

AD-A039676

AMC-DR-1005 ✓



B S

RD-TM-72-5 ✓

EXPERIMENTAL AERODYNAMIC INVESTIGATIONS OF
CONFIGURATION SHAPE FOR RING TAIL MISSILES
AT MACH NUMBERS FROM 0.5 TO 1.3

C. Wayne Dahlke, AMSMI

J.C. Craft, AMSMI

March 1972

Approved for Public Release, Distribution Unlimited



U.S. ARMY MISSILE COMMAND ✓

Redstone Arsenal, Alabama

DDC
RECEIVED
MAY 20 1977
D

DISCLAIMER

*The findings in this report are not to be construed
as an official Department of the Army Position
unless so designated by other authorized documents.*

DISPOSITION INSTRUCTIONS

*Destroy this report when it is no longer needed.
Do not return it to the originator.*

RD-TM-72-5
AMC-DR-1005
MARCH, 1972

EXPERIMENTAL AERODYNAMIC INVESTIGATIONS OF CONFIGURATION SHAPE FOR
RING TAIL MISSILES AT MACH NUMBERS FROM 0.5 TO 1.3

By

C. Wayne Dahlke, AMSMI
J. C. Craft, AMSMI

Approved for public release, distribution unlimited.

RD-TM-72-5
AMC-DR-1005
MARCH, 1972

U.S. ARMY MISSILE COMMAND
WIND TUNNEL TEST DATA REPORT

CONFIGURATION: LONGITUDINALLY SUPPORTED RING TAIL MISSILE
TEST PURPOSE: Parametric Investigations of Missile Configuration

TEST FACILITY: AEDC 4-Foot Transonic (4T) Wind Tunnel
TESTING AGENCY: Army Missile Command
TEST NO. & DATE: AEDC/TC-201, January, 1972
TEST CONDUCTOR(S): C. Wayne Dahlke, J. C. Craft

DATA MANAGEMENT SERVICES

LIAISON: John E. Vaughn DATA OPERATIONS: James B. Ziler
John E. Vaughn

RELEASE APPROVAL: N. D. Kemp
N. D. Kemp, Supervisor
Aero Thermo Data Group

This report has been prepared by Chrysler Corporation Space Division under a Data Management Contract to the NASA. Chrysler assumes no responsibility for the data presented herein other than its display characteristics.

TABLE OF CONTENTS

	<u>PAGE NUMBER</u>
ABSTRACT	iii
NOMENCLATURE	1
INTRODUCTION	3
CONFIGURATIONS INVESTIGATED	4
TEST FACILITY DESCRIPTION	4
REDUCTION OF DATA	5
TABLES	
I. Data Precision	6
II. Data Set Collation Sheets	7
III. Index of Model Figures	9
IV. Index of Data Figures	10
MODEL FIGURES	11
DATA FIGURES	23

EXPERIMENTAL AERODYNAMIC INVESTIGATIONS OF CONFIGURATION SHAPE FOR
RING TAIL MISSILES AT MACH NUMBERS FROM 0.5 TO 1.3

By C. Wayne Dahlke & J. C. Craft

ABSTRACT

Experimental aerodynamic investigations were conducted during January, 1972 at the AEDC PWT 4T wind tunnel on approximately 20 different configurations of ring tail missiles. The more important geometric parameters considered were ring tail support strut length, strut start position, and ring tail to center-body diameter ratio. Six component aerodynamic force and moment data were recorded over an angle of attack range from -6° to 6° at Mach numbers ranging from 0.5 to 1.3.

NOMENCLATURE
General

<u>SYMBOL</u>	<u>SADSAC SYMBOL</u>	<u>DEFINITION</u>
a		speed of sound; m/sec, ft/sec
C_p	CP	pressure coefficient; $(P_1 - P_\infty)/q$
M	MACH	Mach number; V/a
P		pressure; N/m^2 , psf
q	Q(NSM) Q(PSF)	dynamic pressure; $1/2\rho V^2$, N/m^2 , psf
RN/L	RN/L	unit Reynolds number; per m, per ft
V		velocity; m/sec, ft/sec
α	ALPHA	angle of attack, degrees
β	BETA	angle of sideslip, degrees
ψ	PSI	angle of yaw, degrees
ϕ	PHI	angle of roll, degrees
ρ		mass density; kg/m^3 , slugs/ft ³

Reference & C.G. Definitions

A_b		base area; m^2 , ft^2
b	BREF	wing span or reference span; m, ft
$c.g.$		center of gravity
$\frac{l}{c}$	LREF	reference length or wing mean aerodynamic chord; m, ft
S	SREF	wing area or reference area; m^2 , ft^2
	MRP	moment reference point
	XMRP	moment reference point on X axis
	YMRP	moment reference point on Y axis
	ZMRP	moment reference point on Z axis

SUBSCRIPTS

b	base
l	local
s	static conditions
t	total conditions
∞	free stream

NOMENCLATURE
(Continued)

Body-Axis System

<u>SYMBOL</u>	<u>SADSAC SYMBOL</u>	<u>DEFINITION</u>
C_N	CN	normal-force coefficient; $\frac{\text{normal force}}{qS}$
C_A	CA	axial-force coefficient; $\frac{\text{axial force}}{qS}$
C_Y	CY	side-force coefficient; $\frac{\text{side force}}{qS}$
C_{A_b}	CAB	base axial-force coefficient; $\frac{\text{base axial force}}{qS}$ $-A_b(p_b - p_\infty)/qS$
C_{A_f}	CAF	forebody axial force coefficient; $C_A - C_{A_b}$
C_m	CIM	pitching-moment coefficient; $\frac{\text{pitching moment}}{qS l_{REF}}$
C_n	CYN	yawing-moment coefficient; $\frac{\text{yawing moment}}{qS b}$
C_l	CBL	rolling-moment coefficient; $\frac{\text{rolling moment}}{qS b}$

INTRODUCTION

The military services continue to be interested in tube launched missiles. This method of launch rules out large fixed protuberances, such as fins on the missile which are necessary for flight stabilization. One method utilized to aerodynamically stabilize missile shapes without protuberances and which is adaptable to tube launch is the adaptation of a longitudinally supported ring tail (LSRT).

There have been several wind tunnel investigations made in the past on missiles of this type, but they were directed toward system development studies or single parameter variations. There has not been an approach taken to study the various parameters with a single configuration buildup.

The test described herein was designed to provide data for several of the variables that may be considered during the design of a longitudinally supported ring tail missile. Some of these variables are: ring tail support strut length; centerbody loads; centerbody/ring diameter ratio; ring chord length and nose shape.

The basic model configuration was selected from typical tube launched missile designs which from a review study revealed that warheads generally had length to maximum diameter ratios of 3.5 to 4.0. The fore section is typically a blunted 10-15 degree half-angle cone with the aft section of the nose being conical or ogival. When the cones are used the mid section is typically a cylinder followed by a conical boattail with a half angle about the same as the fore section. Figures 1 and 2 are photographs of typical test models installed in the tunnel.

CONFIGURATIONS INVESTIGATED

This investigation utilized one nose section, N_1 ; four solid sleeves (mid sections), M_1 , M_2 , M_3 and M_4 ; six combinations of solid sleeve and ring tail, R_1 , R_2 , R_3 , R_4 , R_5 and R_6 ; five centerbodies, C_1 , C_2 , C_3 , C_4 and C_5 ; and one boattail, B_1 . The Data Set Collation Sheets (Table II) list the various combinations the components were tested in. Figure 3 shows the detail dimensions of the nose and boattail. Figure 4 depicts the solid sleeves. Figure 5 shows the sleeve and ring tail critical dimensions and Figure 6 delineates the centerbody dimensions. Figure 7 parametrically displays the various complete configurations investigated.

TEST FACILITY DESCRIPTION

The AEDC-PWT Aerodynamic Wind Tunnel (4T) is a closed loop, continuous flow, variable density tunnel in which the Mach number can be varied from 0.2 to 1.3. At all Mach numbers, the stagnation pressure can be varied from 200 to 3400 psfa. The test section is 4 feet square and 12.5 feet long with perforated variable porosity (0.5 to 10 percent open) walls. It is completely enclosed in a plenum chamber from which air can be evacuated allowing part of the tunnel airflow to be removed thru the perforated walls of the test section. A more thorough description of the tunnel may be found in Test Facilities Handbook (Ninth Edition) "Propulsion Wind Tunnel Facility, Vol 4," Arnold Engineering Development Center, July 1971.

REDUCTION OF DATA

The six component aerodynamic forces and moments measured by the internal strain gage balance have been reduced to coefficient form in the body prime axis system using the following reference dimensions: (See figure 8.)

$$S_{REF} = \text{body maximum cross sectional area} = 7.068 \text{ in}^2$$

$$D = \ell_{REF} = b_{REF} = \text{body maximum diameter} = 3.0 \text{ inches}$$

Moments are referenced to the missile nose (station 0.0). The body prime axis system maintains the normal force and pitching moment in the pitch plane regardless of model attitude. When the model roll angle is zero the body axis system and the body prime axis system are coincident. For other roll conditions:

$$C_{N_P} = C_N \cos \phi - C_Y \sin \phi$$

$$C_{Y_P} = C_Y \cos \phi + C_N \sin \phi$$

$$C_{M_P} = C_{N_P} (X/\ell_{REF})$$

$$C_{Y_{N_P}} = C_{Y_P} (X/b_{REF})$$

The longitudinal center of pressures (XCP) are presented as a percent of body diameter (XCP/D) with negative direction being aft of the nose; (i.e. a positive normal force gives a negative pitching moment about the missile nose). They were calculated by the equation:

$$XCP/D = C_{m_\alpha} / C_{N_\alpha}$$

with the gradients being determined between ± 1.25 degrees angle of attack.

Table I gives an estimate of the data accuracy.

TABLE I.
DATA PRECISION

M_∞	C_N	C_M	C_A
0.50	± 0.010	± 0.040	± 0.020
0.80	± 0.006	± 0.023	± 0.012
0.95	± 0.005	± 0.021	± 0.011
1.00	± 0.005	± 0.020	± 0.010
1.05	± 0.005	± 0.019	± 0.010
1.10	± 0.005	± 0.019	± 0.010
1.20	± 0.005	± 0.018	± 0.010
1.30	± 0.005	± 0.018	± 0.009

TABLE III. INDEX OF MODEL FIGURES

<u>Figure</u>	<u>Title</u>	<u>Page</u>
1	Model $N_1M_2B_1C_1$ Installed in AEDC-PWT 4T Wind Tunnel	12
2	Model $N_1R_1C_2$ Installed in AEDC-PWT 4T Wind Tunnel	13
3	Nose, N_1 and Boattail B_1 Details	14
4	Solid Sleeve Details	15
5	Solid Sleeve with Ring Tail Details	16
6	Centerbody Details	17
7	Model Assembly Details	18
8	Axis System	22

TABLE IV. INDEX OF DATA FIGURES

Plot Title	Plot Schedule	Varying Condition	Page
Basic Longitudinal Characteristics	A	Mach No.	1-110
Effect of Afterbody Length	B	Configuration	111-112
Effect of Afterbody Length with Centerbody	C	Configuration	113-114
Centerbody Diameter Effect (No Ring)	C	Configuration	115-118
Centerbody Diameter Effect (With Ring)	C	Configuration	119-122
Effect of Afterbody Length and Centerbody	C	Configuration	123-126
Effect of Strut Length	C	Configuration	127-128
Effect of Strut Length with Centerbody	C	Configuration	129-130
Effect of Strut Length and Centerbody Diameter	C	Configuration	131-132
Effect of Strut Length and Centerbody Length	C	Configuration	133-134
Effect of Strut Width	C	Configuration	135-136
Loads on Centerbody (with Ring)	C	Configuration	137-138
Effect of Aspect Ratio	C	Configuration	139-140
Effect of Aspect Ratio and Centerbody Diameter	C	Configuration	141-142
Effect of Boattail	C	Configuration	143-144
Effect of Model Roll Angle	C	Roll Angle	145-152

Plot Schedules:

- A) C_N, C_m vs. α
- B) $C_{N\alpha}, C_{m\alpha}, XCP/D, (C_A)_{\alpha=0}, (C_{AF})_{\alpha=0}$ vs. Mach number
- C) $C_{N\alpha}, C_{m\alpha}, XCP/D, (C_A)_{\alpha=0}$ vs. Mach number

MODEL FIGURES

FIGURE 1. MODEL $N_1M_2B_1C_1$ INSTALLED IN AEDC-PWT 4T WIND TUNNEL

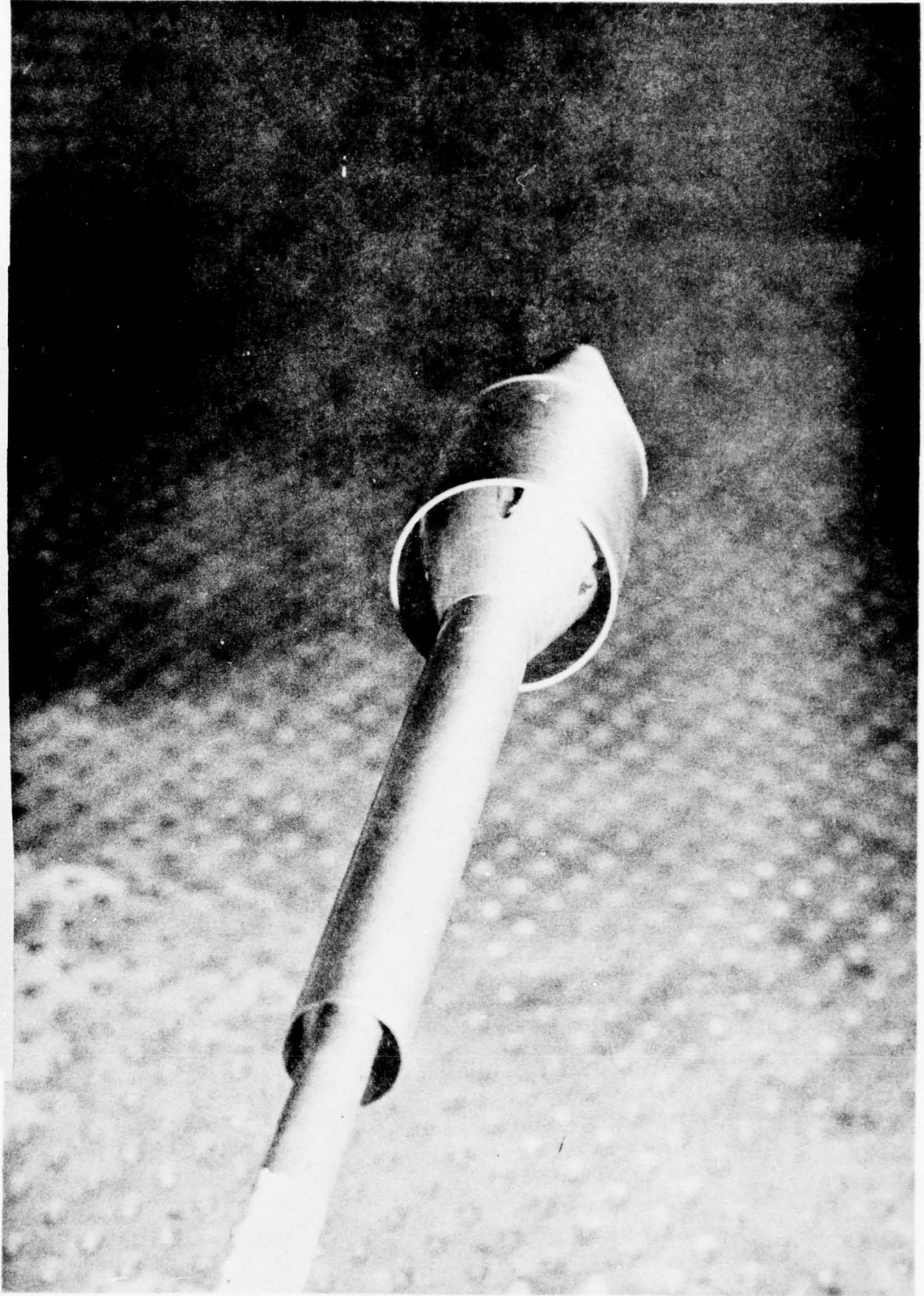
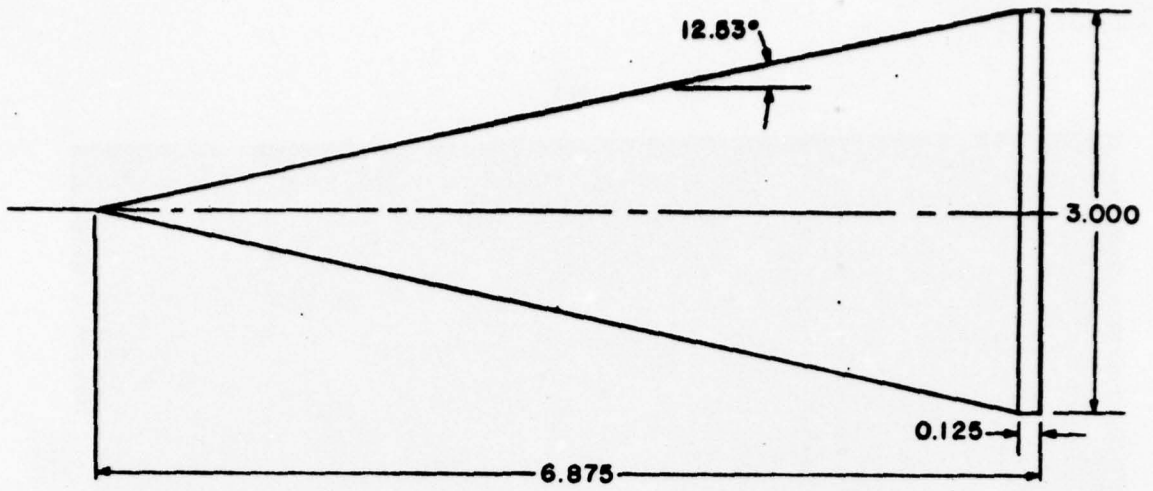
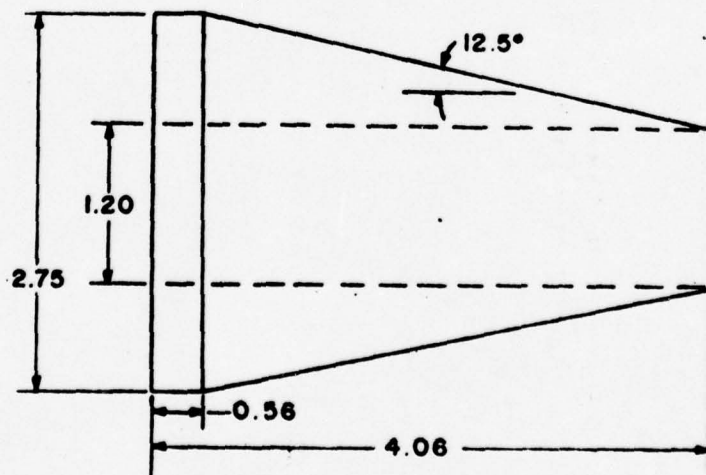

FIGURE 2. MODEL N₁R₁C₂ INSTALLED IN AEDC-PWT 4T WIND TUNNEL.





NOSE ASSEMBLY (N1)



BOATTAIL (B1)

ALL DIMENSIONS IN INCHES

FIGURE 3. NOSE, N₁ AND BOATTAIL B₁ DETAILS

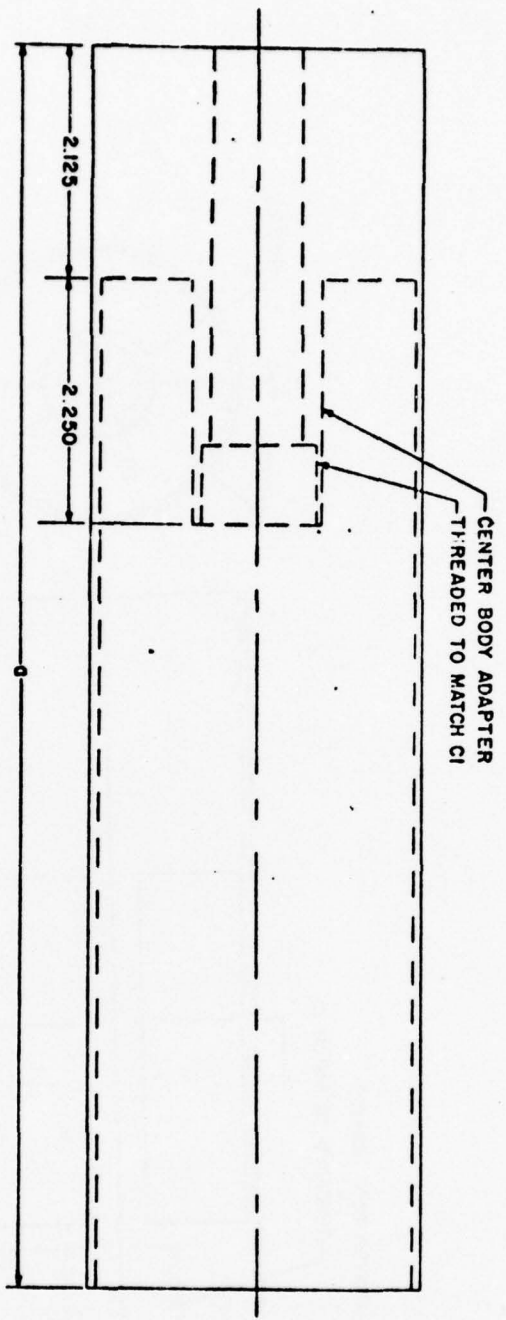

CONFIG	d
M1	6.625
M2	4.375
M3	2.125
M4	17.125

ALL DIMENSIONS IN INCHES

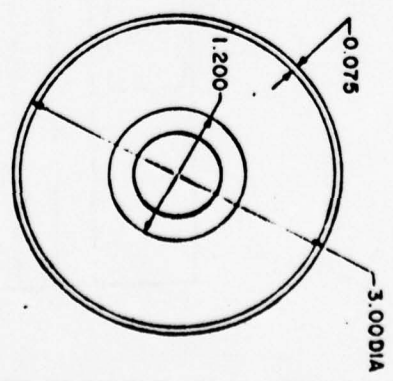
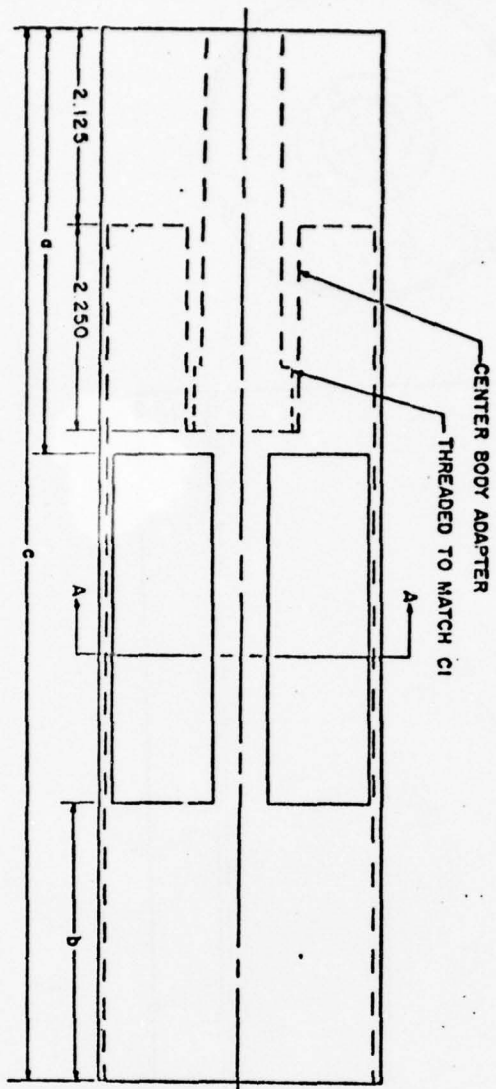

FIGURE 4. SOLID SLEEVE DETAILS



CONFIG	d	b	c	g
R1	6.625	3.000	17.125	0.600
R2	4.375	3.000	17.125	0.600
R3	2.125	3.000	17.125	0.600
R4	6.625	1.500	17.125	0.600
R5	6.625	3.000	17.125	1.200
R6	6.625	2.000	21.625	0.600

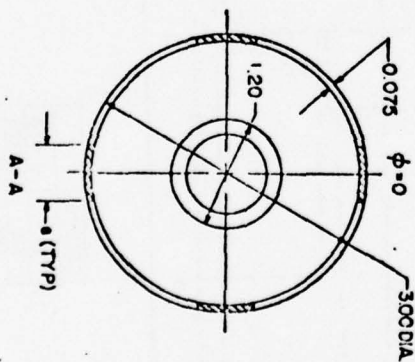
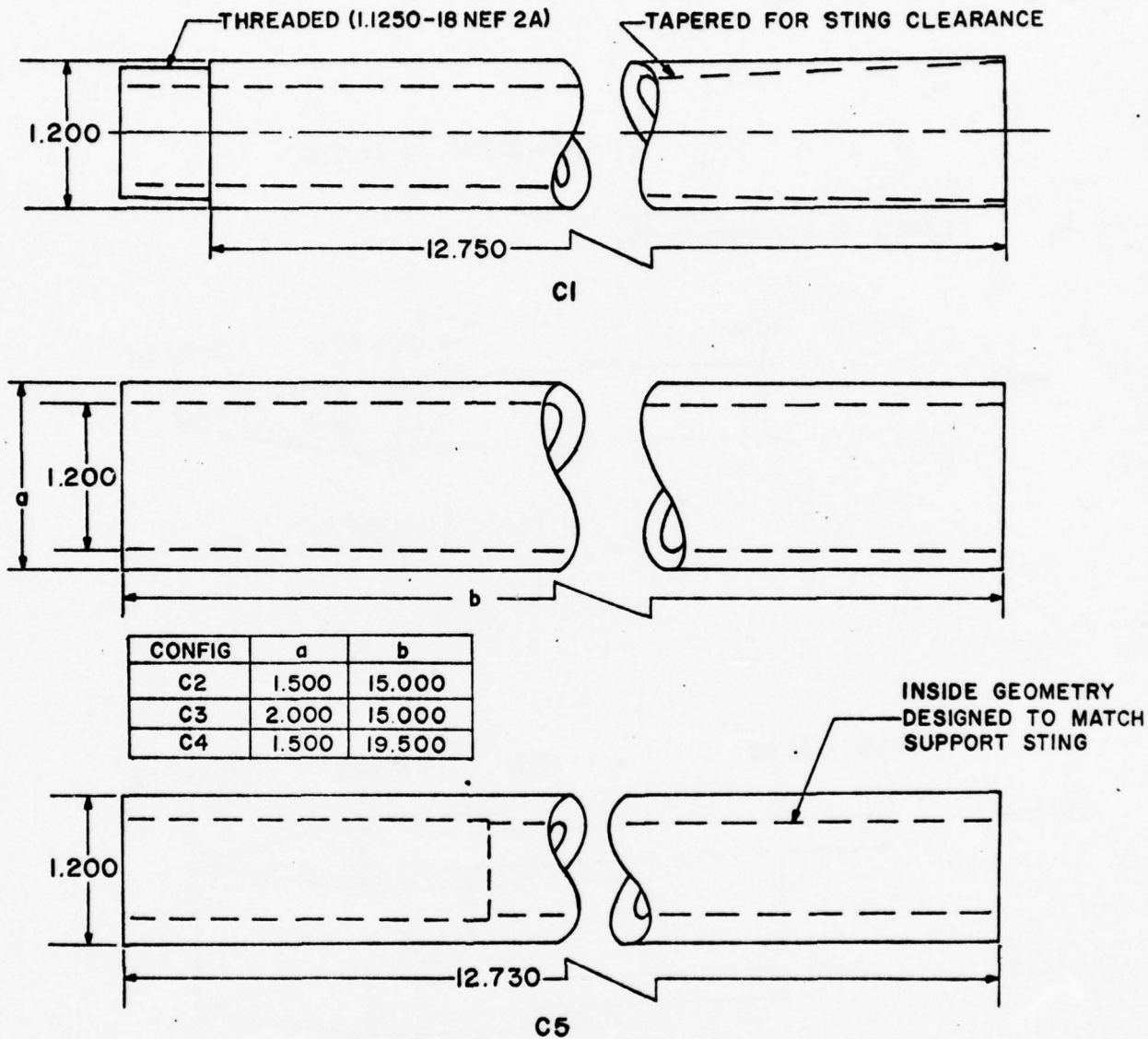

FIGURE 5. SOLID SLEEVE WITH RING TAIL DETAILS

ALL DIMENSIONS IN INCHES



ALL DIMENSIONS IN INCHES

FIGURE 6. CENTERBODY DETAILS

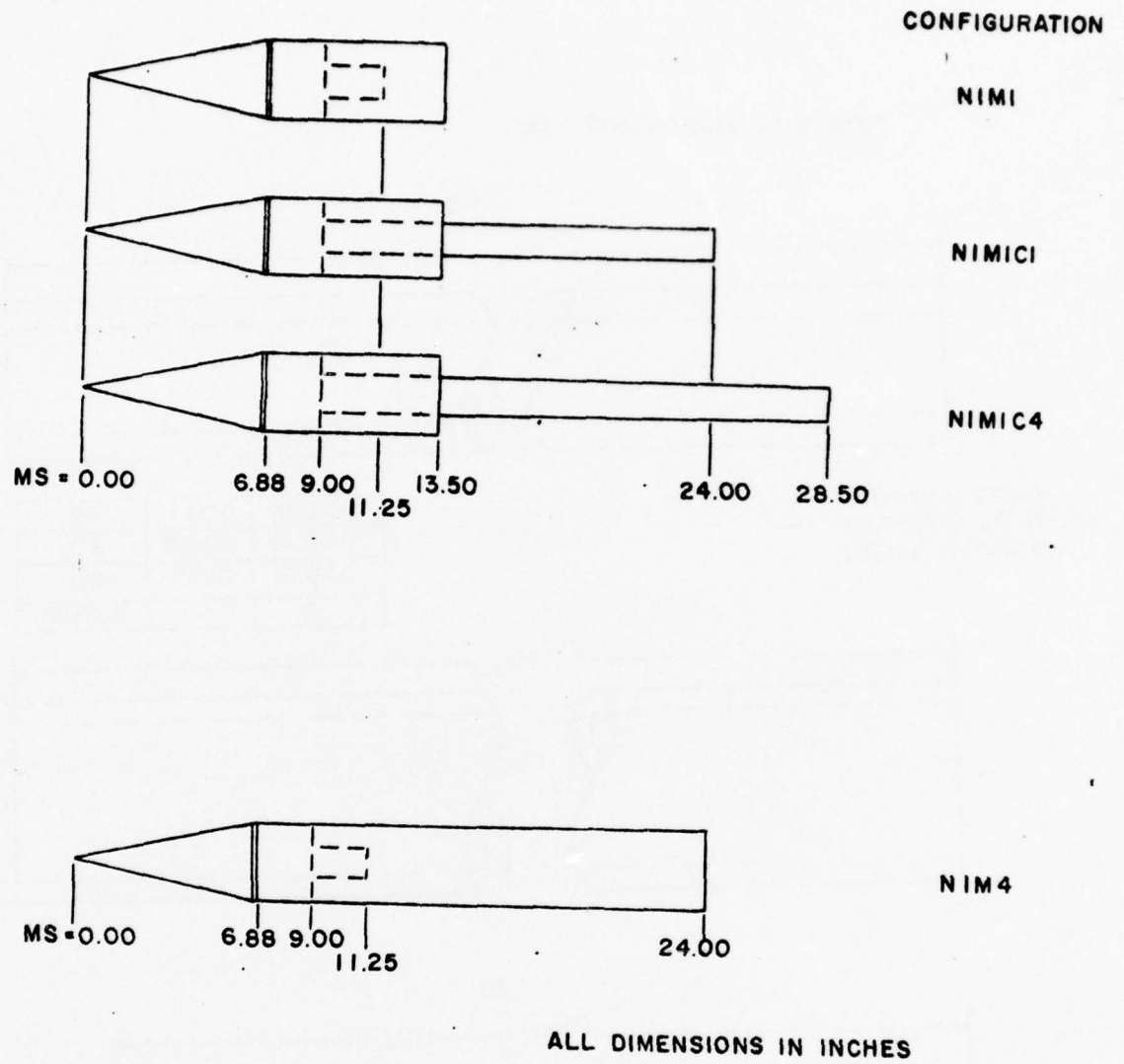
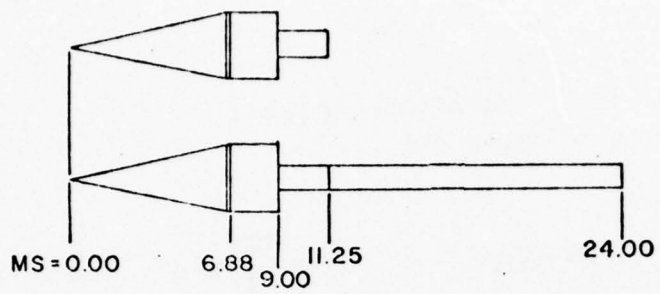

FIGURE 7. MODEL ASSEMBLY DETAILS



CONFIGURATION

NIM3

NIM3CI

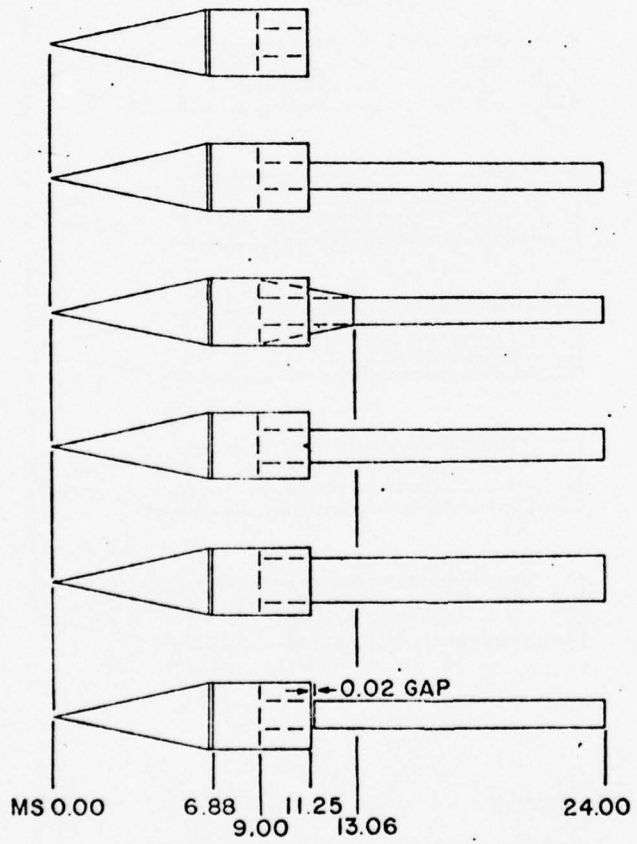

NIM2

NIM2CI

NIM2CIBI

NIM2C2

NIM2C3

NIM2C5

ALL DIMENSIONS IN INCHES

FIGURE 7. (CONTINUED)

CONFIGURATION

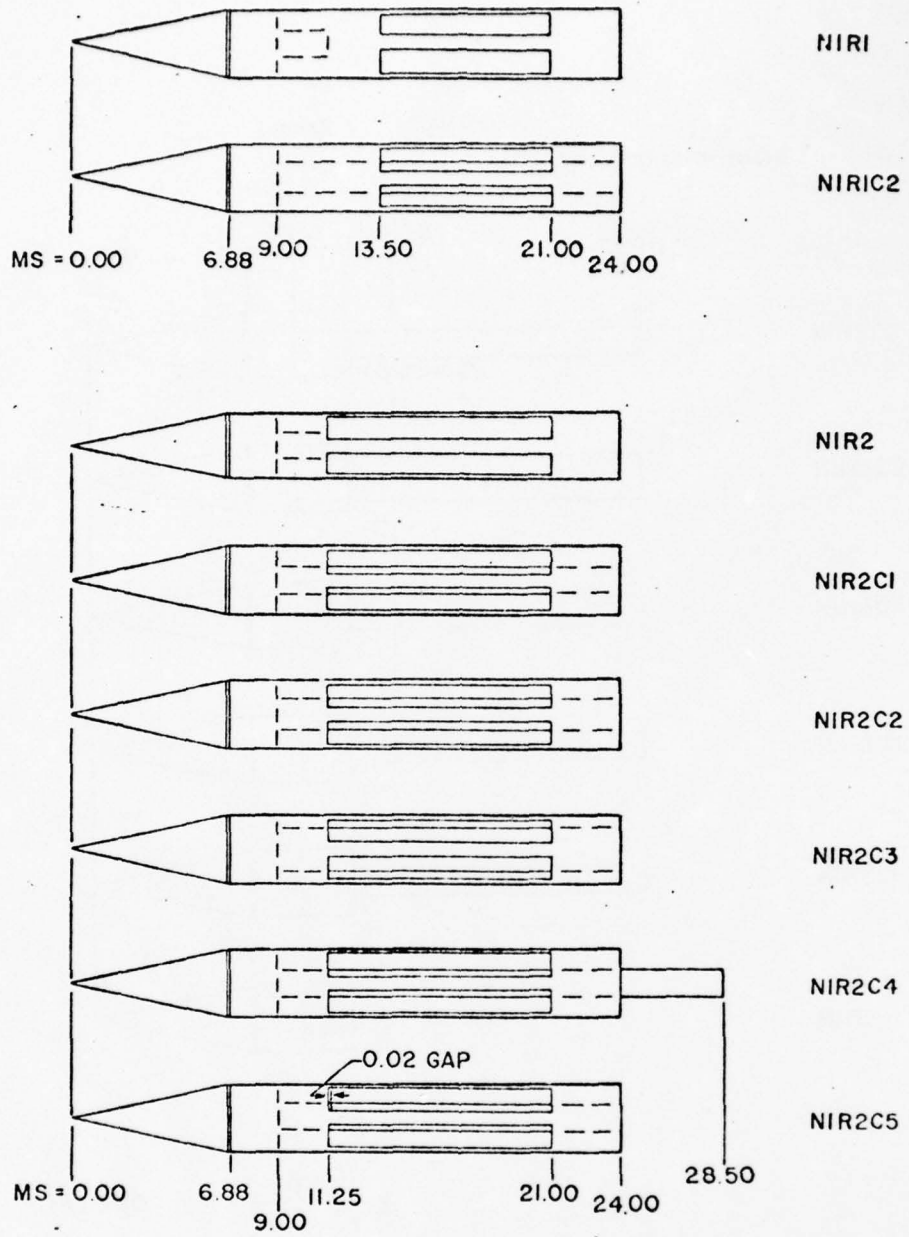

ALL DIMENSIONS IN INCHES

FIGURE 7. (CONTINUED)

CONFIGURATION

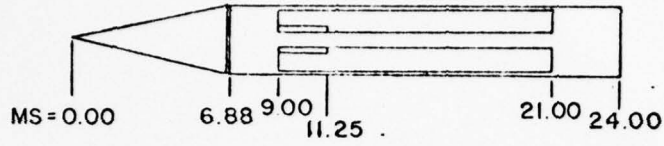

NIR3

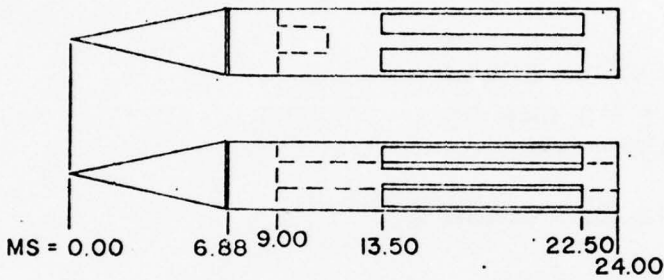

NIR4

NIR4CI

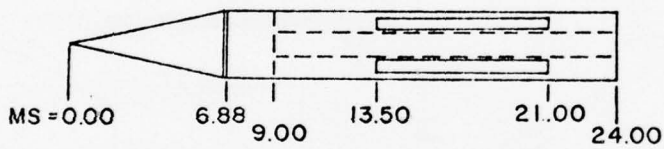

NIR5CI

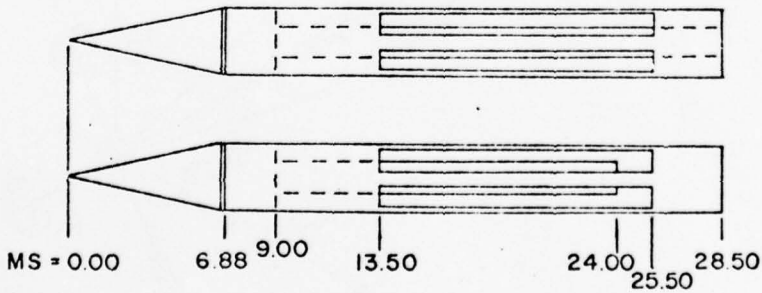

NIR6C4

NIR6C2

ALL DIMENSIONS IN INCHES

FIGURE 7. (CONTINUED)

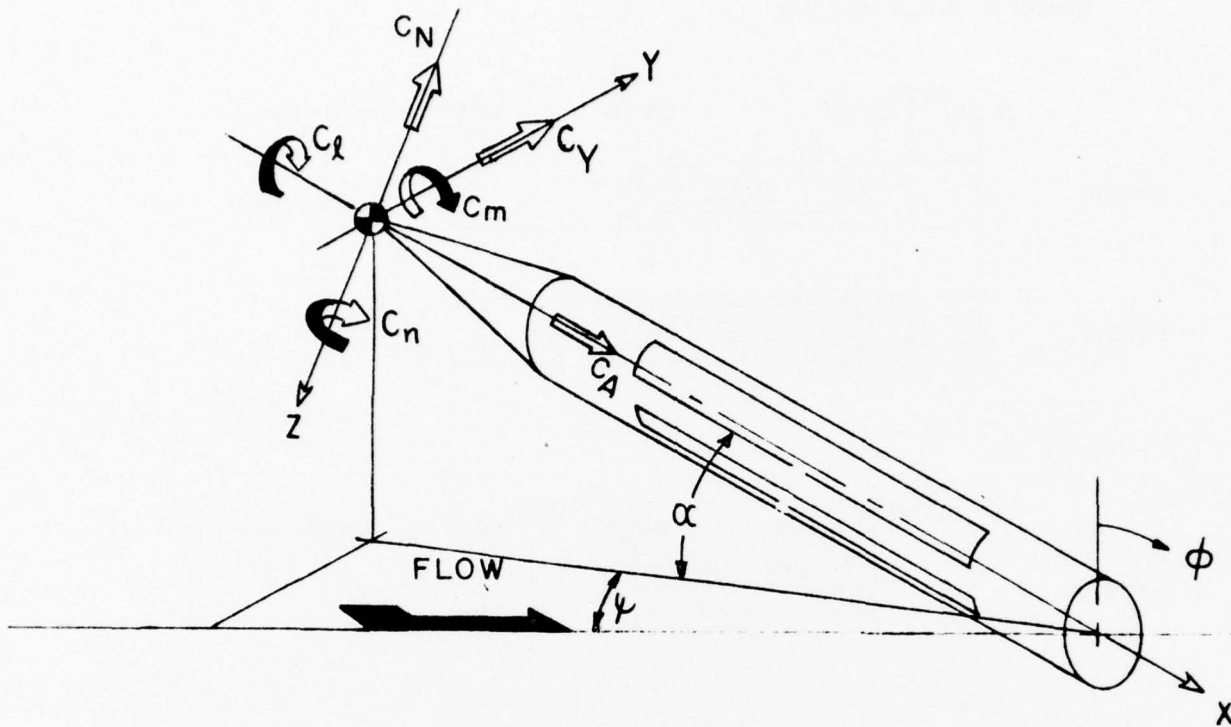

⊙ MOMENT REFERENCE LOCATION (NOSE APEX)

NOTE: POSITIVE DIRECTIONS SHOWN.
 C_N AND C_m ARE IN THE PITCH
 PLANE REGARDLESS OF THE MODEL
 ATTITUDE

FIGURE 8. AXIS SYSTEM

D A T A F I G U R E S

Note: Tabular Data are available upon request.
If interested contact report originator.

BASIC LONGITUDINAL CHARACTERISTICS

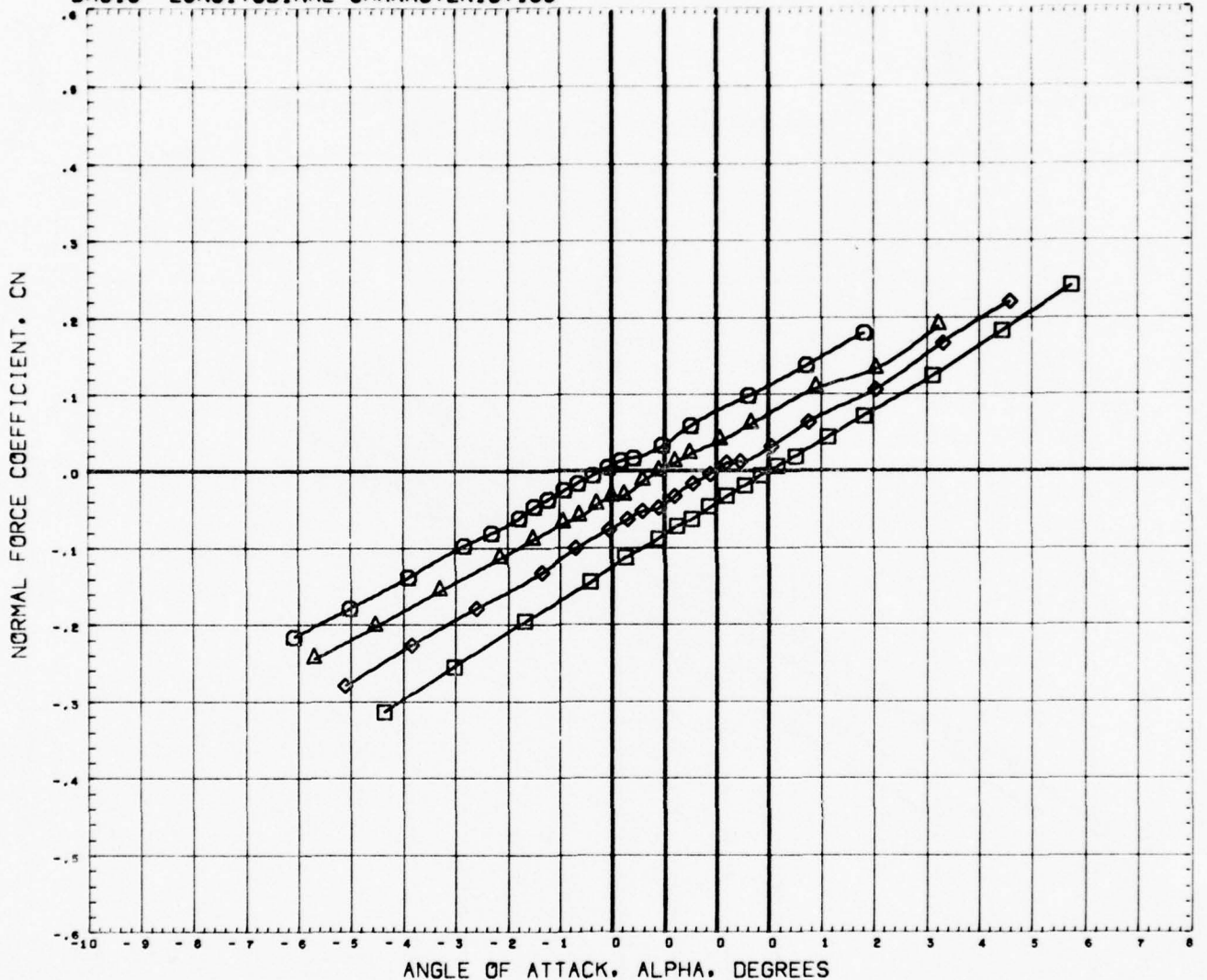

SYMBOL	MACH	PHI	PARAMETRIC VALUES		REFERENCE INFORMATION			
○	0.499		0.000	M-LGTH	2.250	SREF	7.0686	SQ. IN.
△	0.802					LREF	3.0000	INCHES
◇	0.948					BREF	3.0000	INCHES
□	1.000					XMRP	0.0000	INCHES
						YMRP	0.0000	INCHES
						ZMRP	0.0000	INCHES
						SCALE	0.0000	NONE

REFERENCE FILE

AEDC TEST PWT-4T201 CONE-CYLINDER, N1M1

(RTAM01) 10 MAR 72

PAGE 1

BASIC LONGITUDINAL CHARACTERISTICS

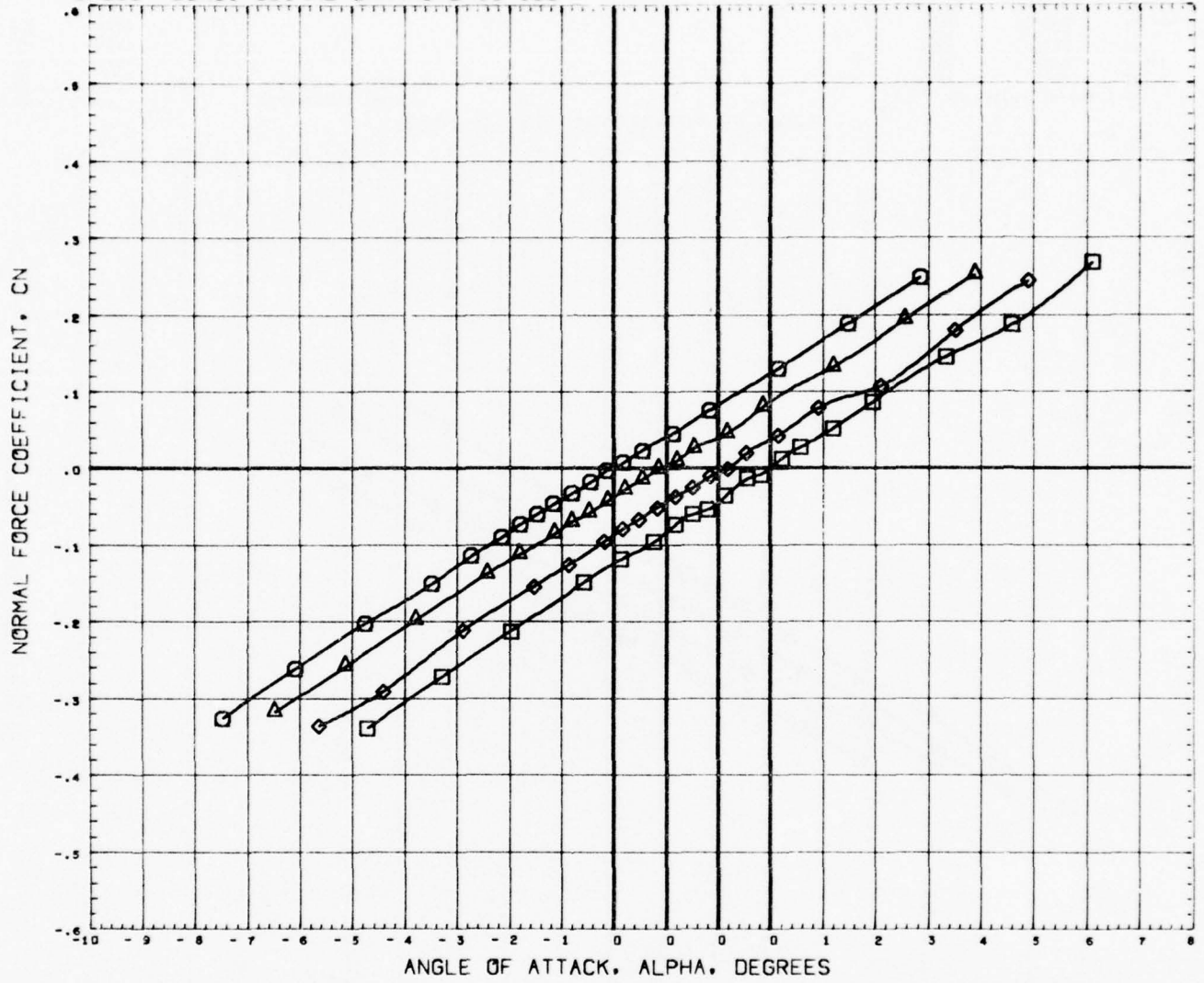

SYMBOL	MACH	PHI	PARAMETRIC VALUES		REFERENCE INFORMATION	
○	1.050		0.000	M-LGTH	2.250	SREF 7.0686 SQ. IN.
△	1.095					LREF 3.0000 INCHES
◇	1.198					BREF 3.0000 INCHES
□	1.297					XHRP 0.0000 INCHES
						YHRP 0.0000 INCHES
						ZHRP 0.0000 INCHES
						SCALE 0.0000 NONE

REFERENCE FILE

AEDC TEST PWT-4T201 CONE-CYLINDER, N1M1

(RTAM01) 10 MAR 72 PAGE 2

BASIC LONGITUDINAL CHARACTERISTICS

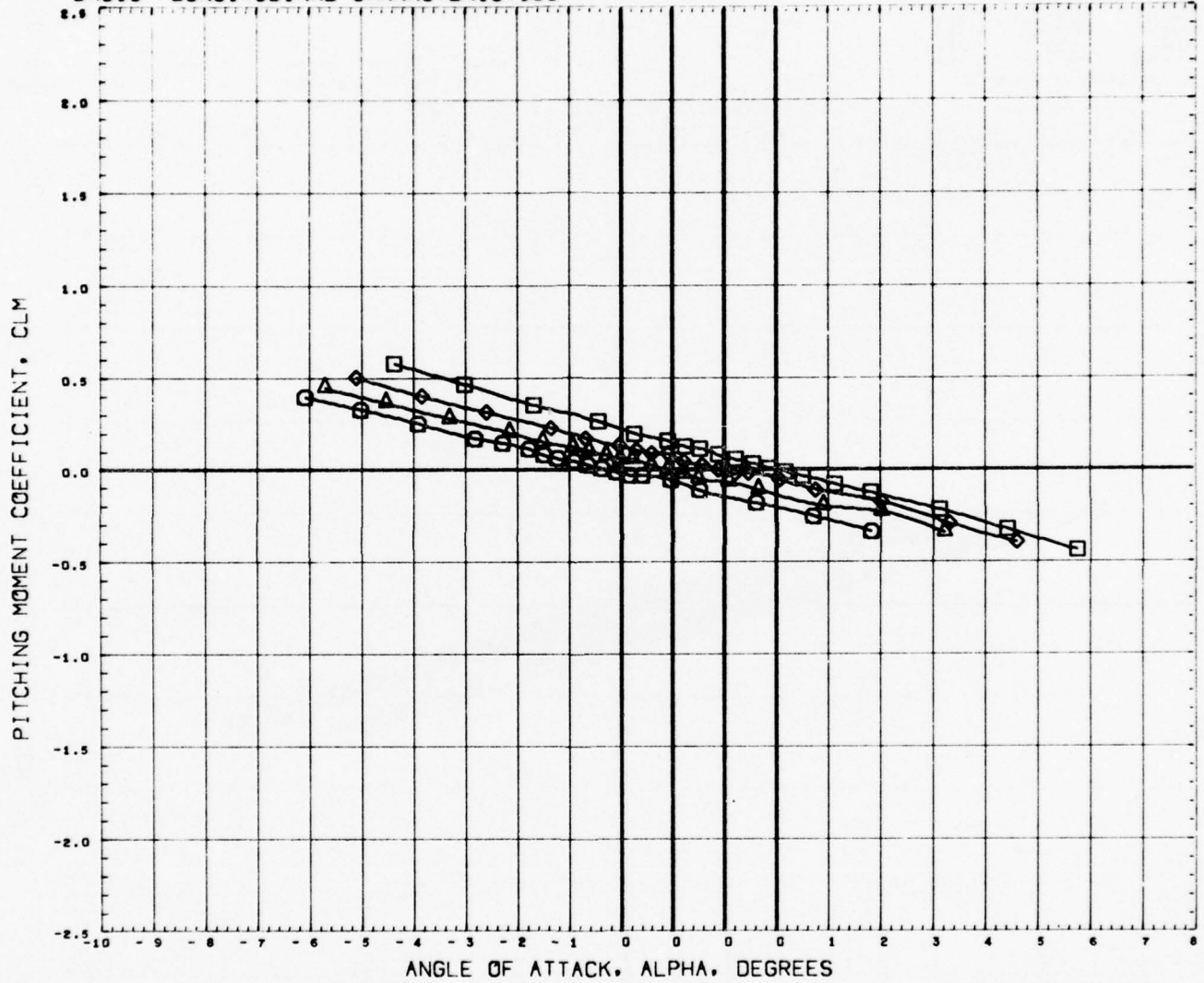

SYMBOL	MACH	PHI	PARAMETRIC VALUES	
○	0.499		0.000	M-LGTH 2.250
△	0.802			
◇	0.948			
□	1.000			

REFERENCE INFORMATION		
SREF	7.0686	50. IN.
LREF	3.0000	INCHES
BREF	3.0000	INCHES
XNRP	0.0000	INCHES
YNRP	0.0000	INCHES
ZNRP	0.0000	INCHES
SCALE	0.0000	NONE

REFERENCE FILE

AEDC TEST PWT-4T201 CONE-CYLINDER, N1M1

(RTAM01) 10 MAR 72 PAGE 3

BASIC LONGITUDINAL CHARACTERISTICS

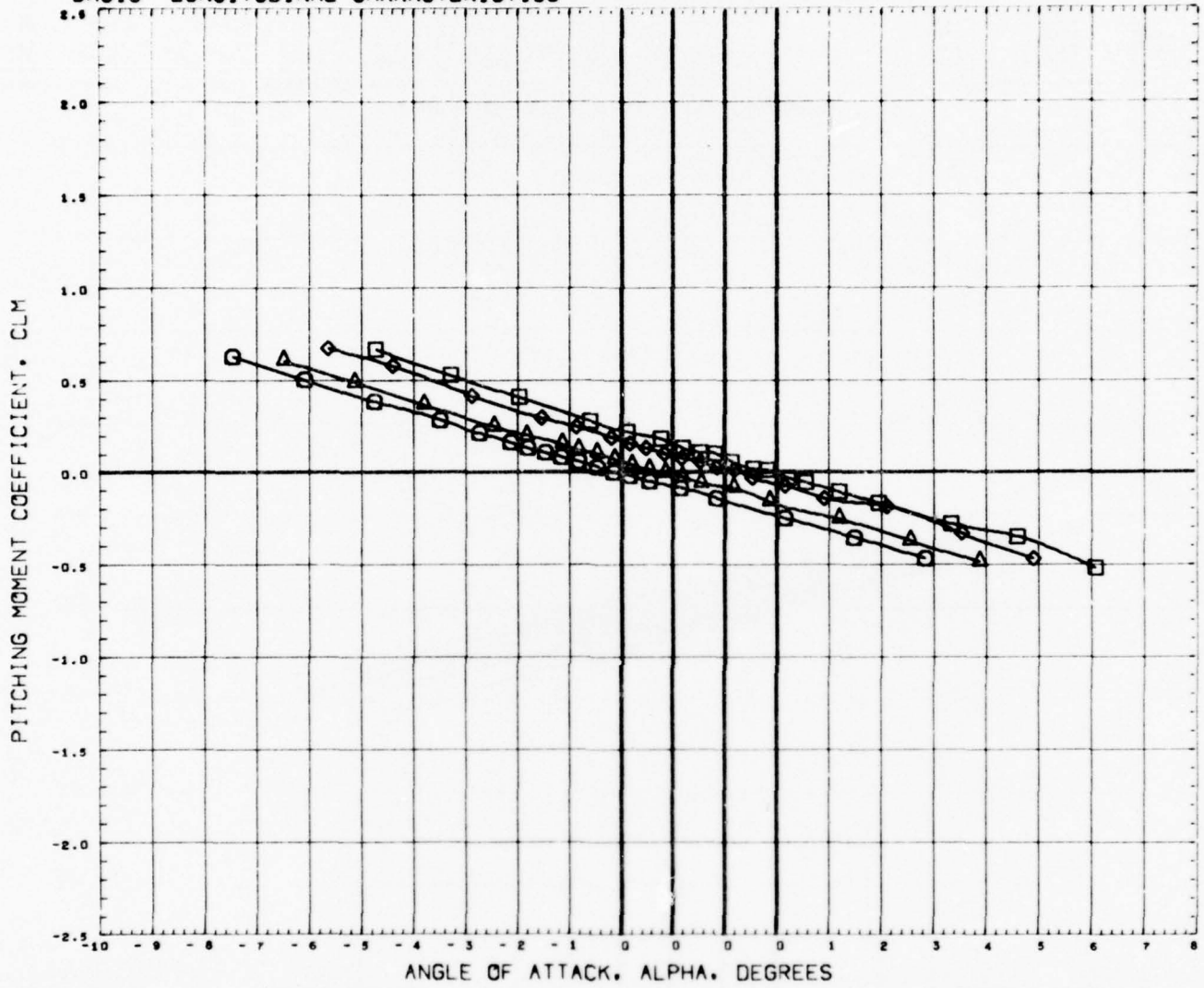

SYMBOL	MACH	PHI	PARAMETRIC VALUES	
○	1.050		0.000	M-LGTH 2.250
△	1.095			
◇	1.198			
□	1.297			

REFERENCE INFORMATION		
SREF	7.0686	sq. in.
LREF	3.0000	INCHES
BREF	3.0000	INCHES
XMRP	0.0000	INCHES
YMRP	0.0000	INCHES
ZMRP	0.0000	INCHES
SCALE	0.0000	NONE

REFERENCE FILE

AEDC TEST PWT-4T201 CONE-CYLINDER, N1M1

(RTAM01) 10 MAR 72

PAGE 4

BASIC LONGITUDINAL CHARACTERISTICS

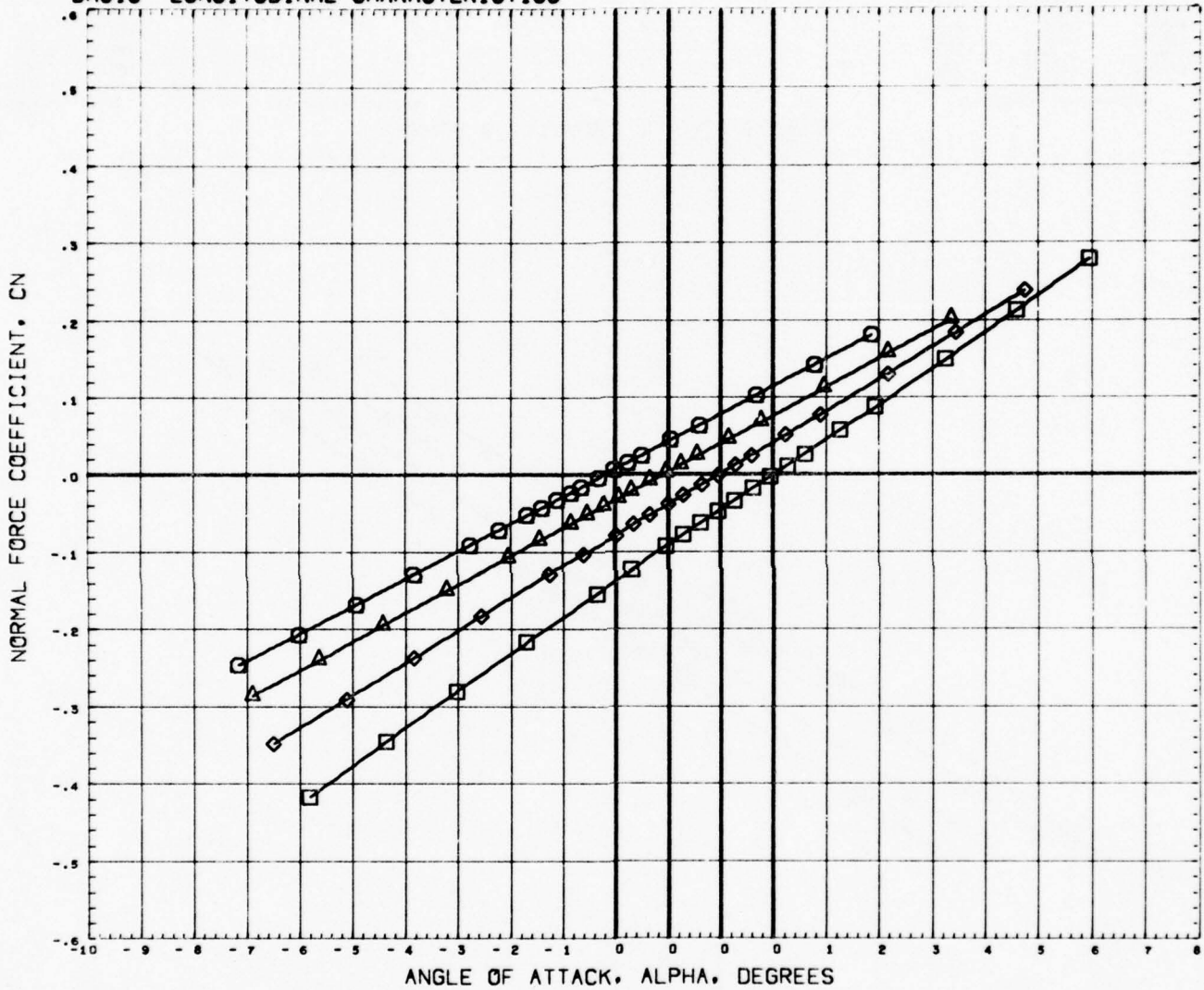

SYMBOL	MACH	PHI	PARAMETRIC VALUES	
○	0.499	0.000	M-LGTH	1.500
△	0.802			
◇	0.951			
□	1.004			

REFERENCE INFORMATION		
SREF	7.0686	50. IN.
LREF	3.0000	INCHES
BREF	3.0000	INCHES
XMRP	0.0000	INCHES
YMRP	0.0000	INCHES
ZMRP	0.0000	INCHES
SCALE	0.0000	NONE

REFERENCE FILE

AEDC TEST PWT-4T201 CONE-CYLINDER, N1M2

(RTAM02) 10 MAR 72 PAGE 5

BASIC LONGITUDINAL CHARACTERISTICS

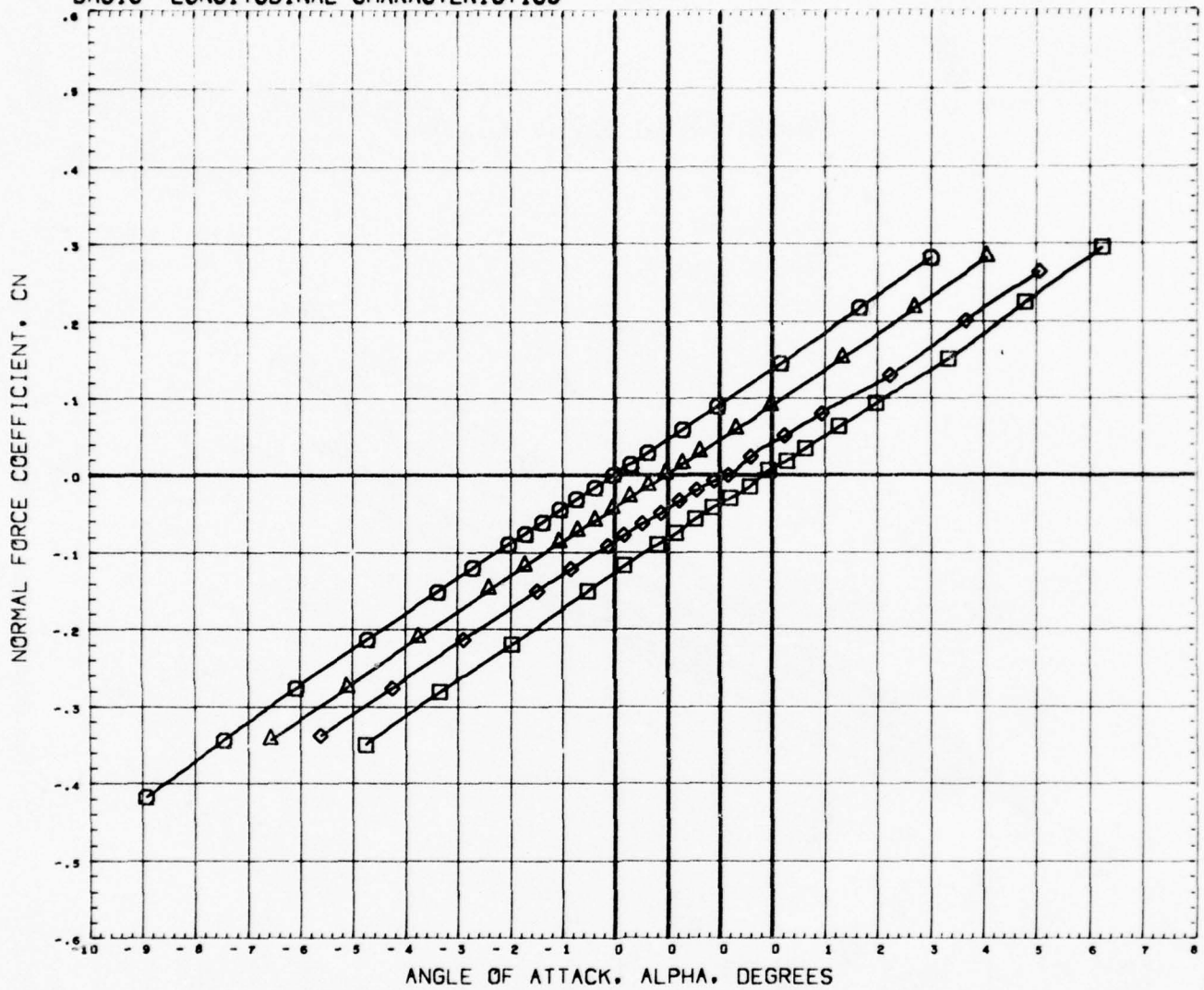

SYMBOL	MACH	PHI	PARAMETRIC VALUES	
○	1.050		0.000	M-LGTH 1.500
△	1.097			
◇	1.197			
□	1.295			

REFERENCE INFORMATION		
SREF	7.0686	50. IN.
LREF	3.0000	INCHES
BREF	3.0000	INCHES
XWRP	0.0000	INCHES
YWRP	0.0000	INCHES
ZWRP	0.0000	INCHES
SCALE	0.0000	NONE

REFERENCE FILE

AEDC TEST PWT-4T201 CONE-CYLINDER, N1M2

(RTAM02) 10 MAR 72

PAGE

6

BASIC LONGITUDINAL CHARACTERISTICS

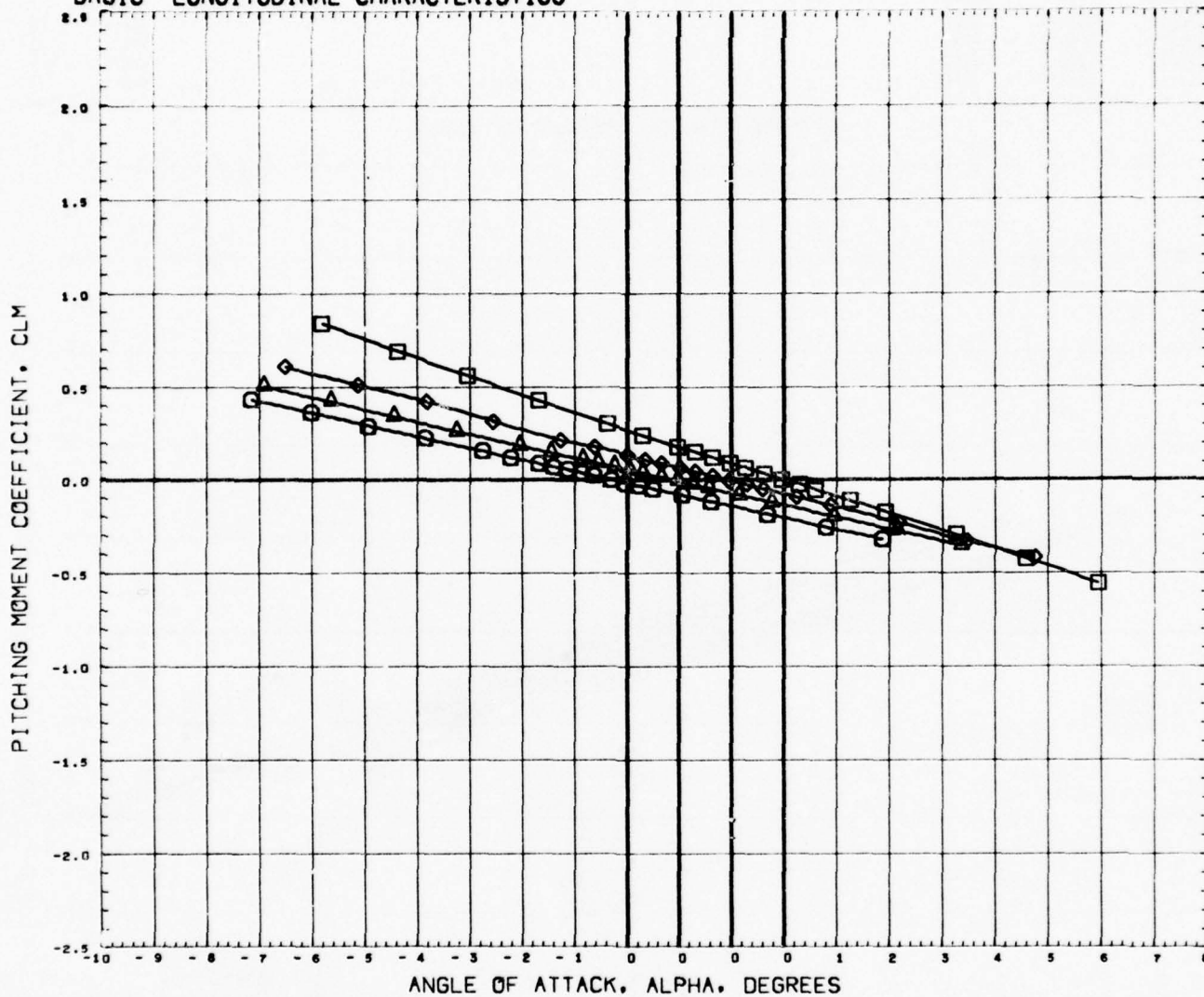

SYMBOL	MACH	PHI	PARAMETRIC VALUES	
○	0.499	0.000	M-LGTH	1.500
△	0.802			
◇	0.951			
□	1.004			

REFERENCE INFORMATION		
SREF	7.0686	50. IN.
LREF	3.0000	INCHES
BREF	3.0000	INCHES
XWRF	0.0000	INCHES
YWRF	0.0000	INCHES
ZWRF	0.0000	INCHES
SCALE	0.0000	NONE

REFERENCE FILE

AEDC TEST PWT-4T201 CONE-CYLINDER, N1M2

(RTAM02) 10 MAR 72 PAGE 7

BASIC LONGITUDINAL CHARACTERISTICS

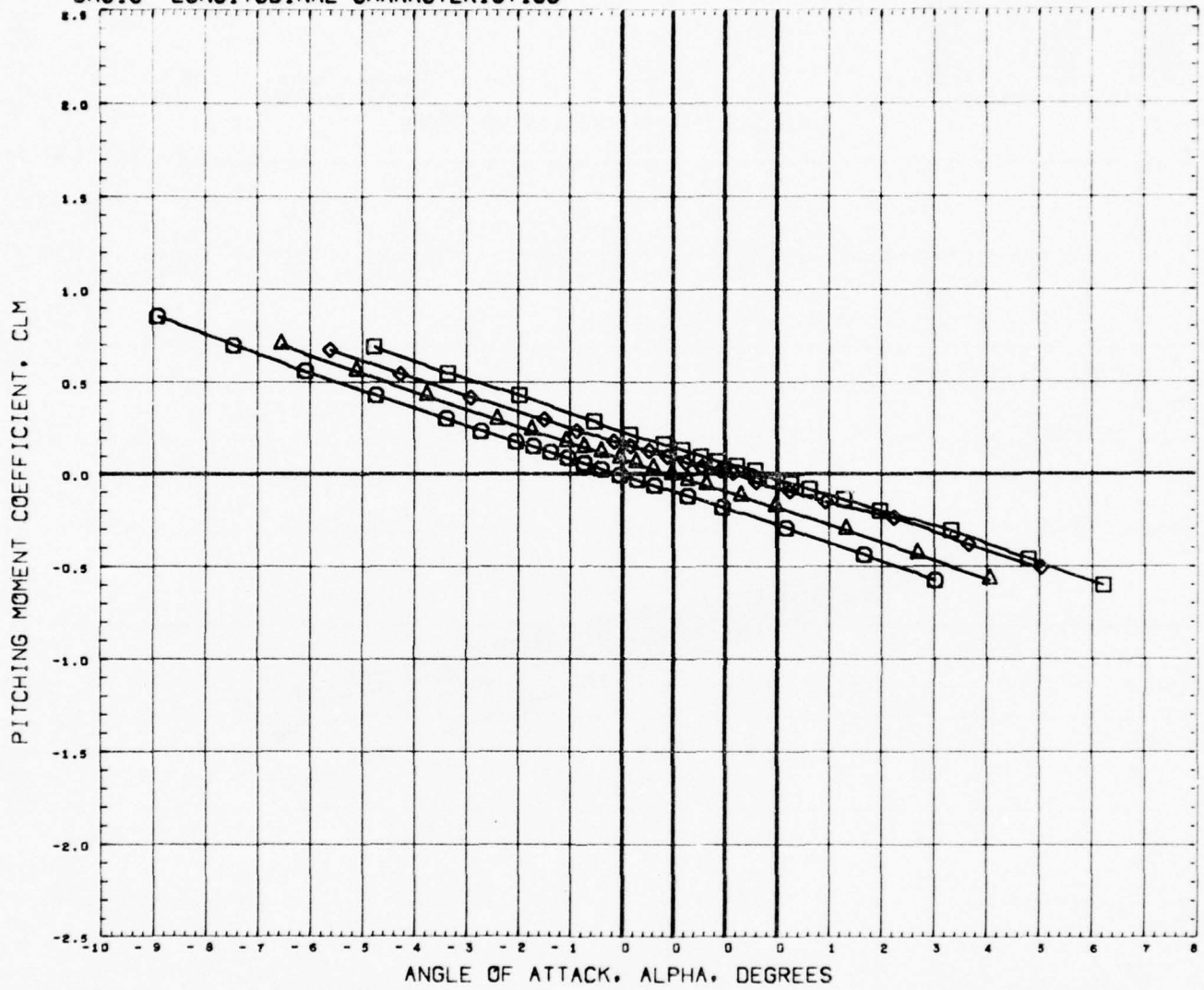

SYMBOL	MACH	PHI	PARAMETRIC VALUES	
○	1.050		0.000	M-LENGTH 1.500
△	1.097			
◇	1.197			
□	1.295			

REFERENCE INFORMATION		
SREF	7.0686	SQ. IN.
LREF	3.0000	INCHES
BREF	3.0000	INCHES
XMRP	0.0000	INCHES
YMRP	0.0000	INCHES
ZMRP	0.0000	INCHES
SCALE	0.0000	NONE

REFERENCE FILE

AEDC TEST PWT-4T201 CONE-CYLINDER, N1M2

(RTAM02) 10 MAR 72

PAGE

8

BASIC LONGITUDINAL CHARACTERISTICS

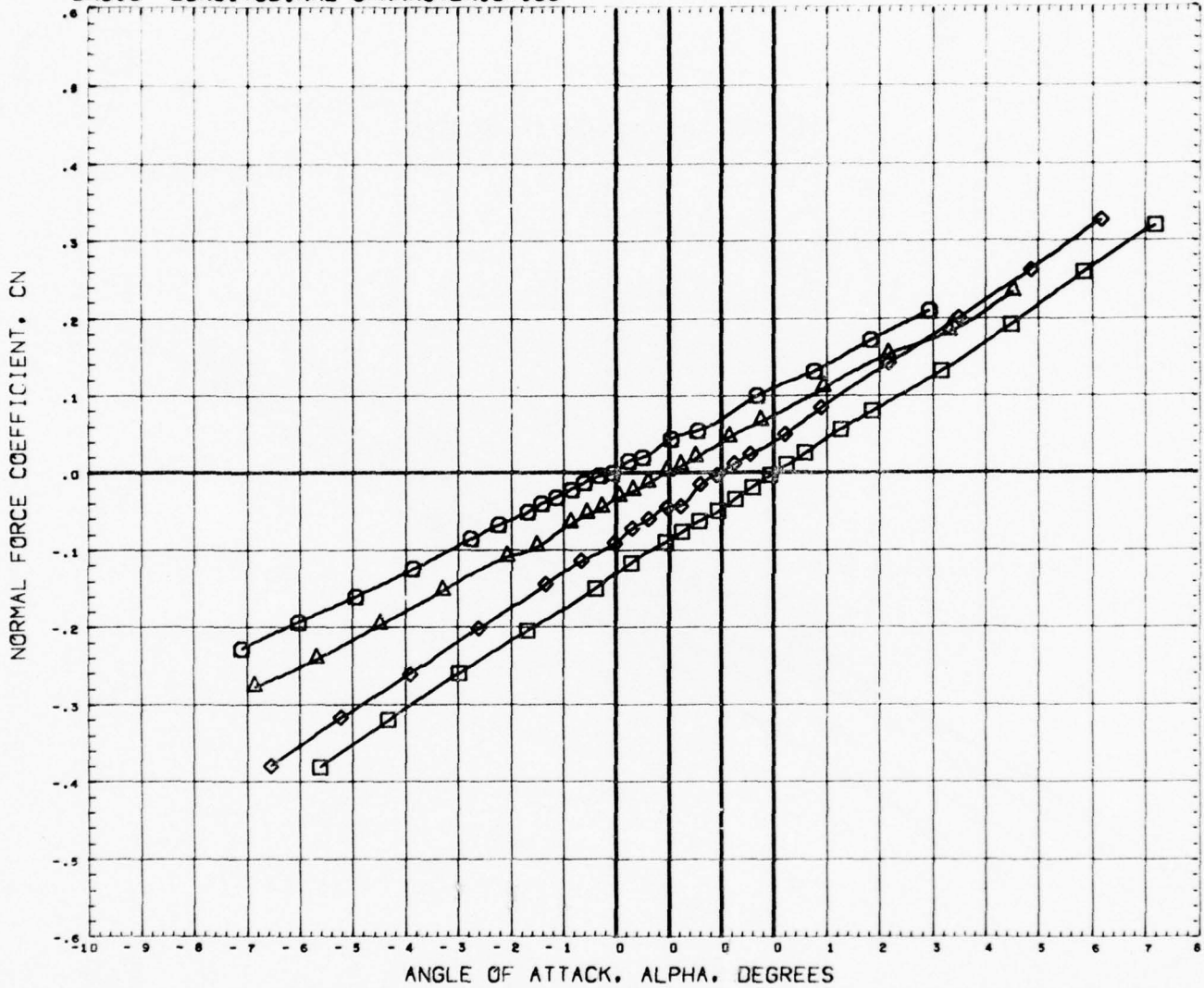

SYMBOL	MACH	PHI	PARAMETRIC VALUES	
○	0.499		0.000	M-LGTH 0.750
△	0.800			
◇	0.952			
□	0.996			

REFERENCE INFORMATION		
SREF	7.0686	SQ. IN.
LREF	3.0000	INCHES
BREF	3.0000	INCHES
XMRP	0.0000	INCHES
YMRP	0.0000	INCHES
ZMRP	0.0000	INCHES
SCALE	0.0000	NONE

REFERENCE FILE

AEOC TEST PWT-4T201 CONE-CYLINDER, N1M3

(RTAM03) 10 MAR 72 PAGE 9

BASIC LONGITUDINAL CHARACTERISTICS

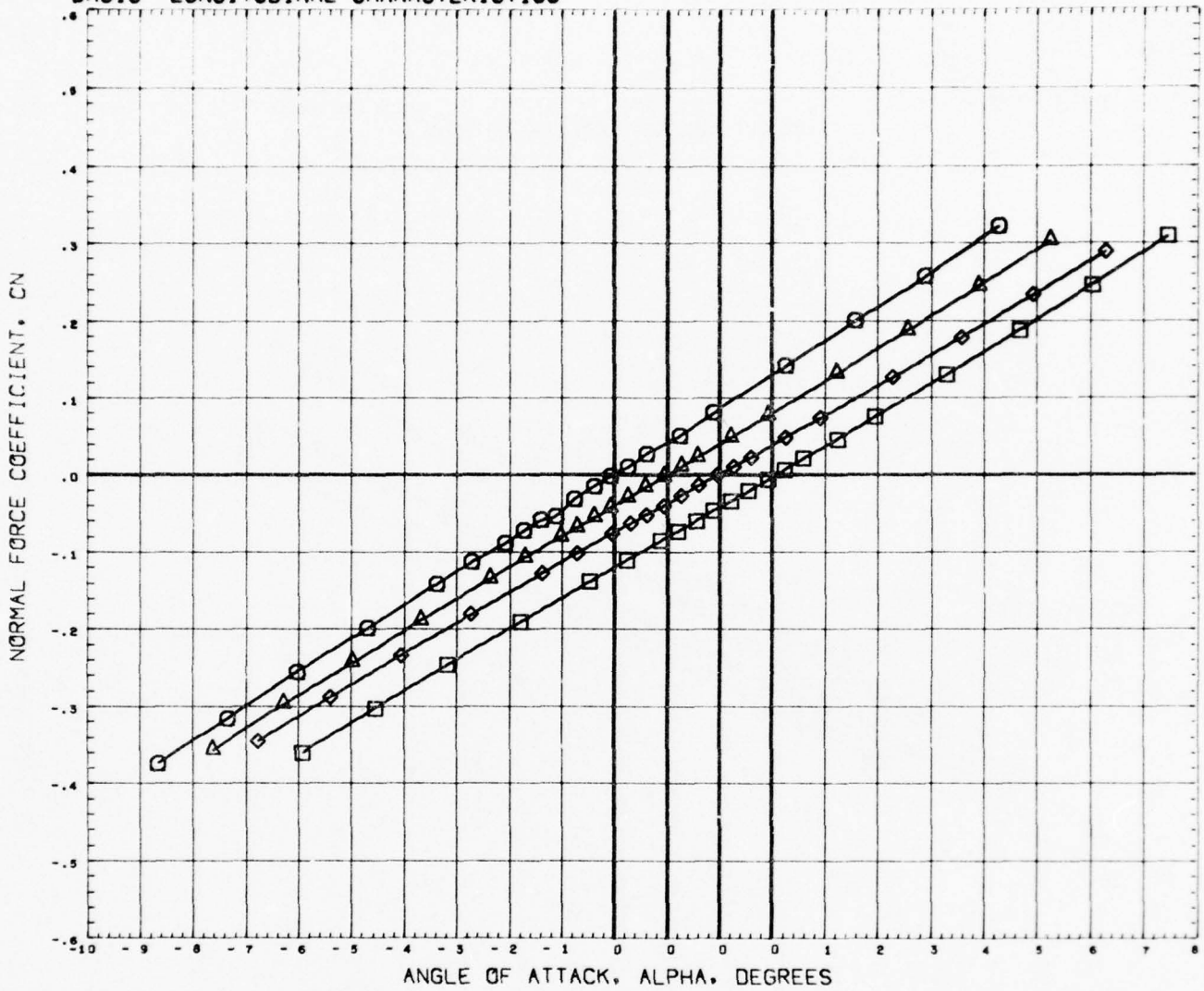

SYMBOL	MACH	PHI	PARAMETRIC VALUES	
○	1.051		0.000	M-LGTH 0.750
△	1.096			
◇	1.200			
□	1.300			

REFERENCE INFORMATION		
SREF	7.0686	SQ. IN.
LREF	3.0000	INCHES
BREF	3.0000	INCHES
XMRP	0.0000	INCHES
YMRP	0.0000	INCHES
ZMRP	0.0000	INCHES
SCALE	0.0000	NONE

REFERENCE FILE

AEDC TEST PWT-4T201 CONE-CYLINDER, N1M3

(RTAM03) 10 MAR 72

PAGE 10

BASIC LONGITUDINAL CHARACTERISTICS

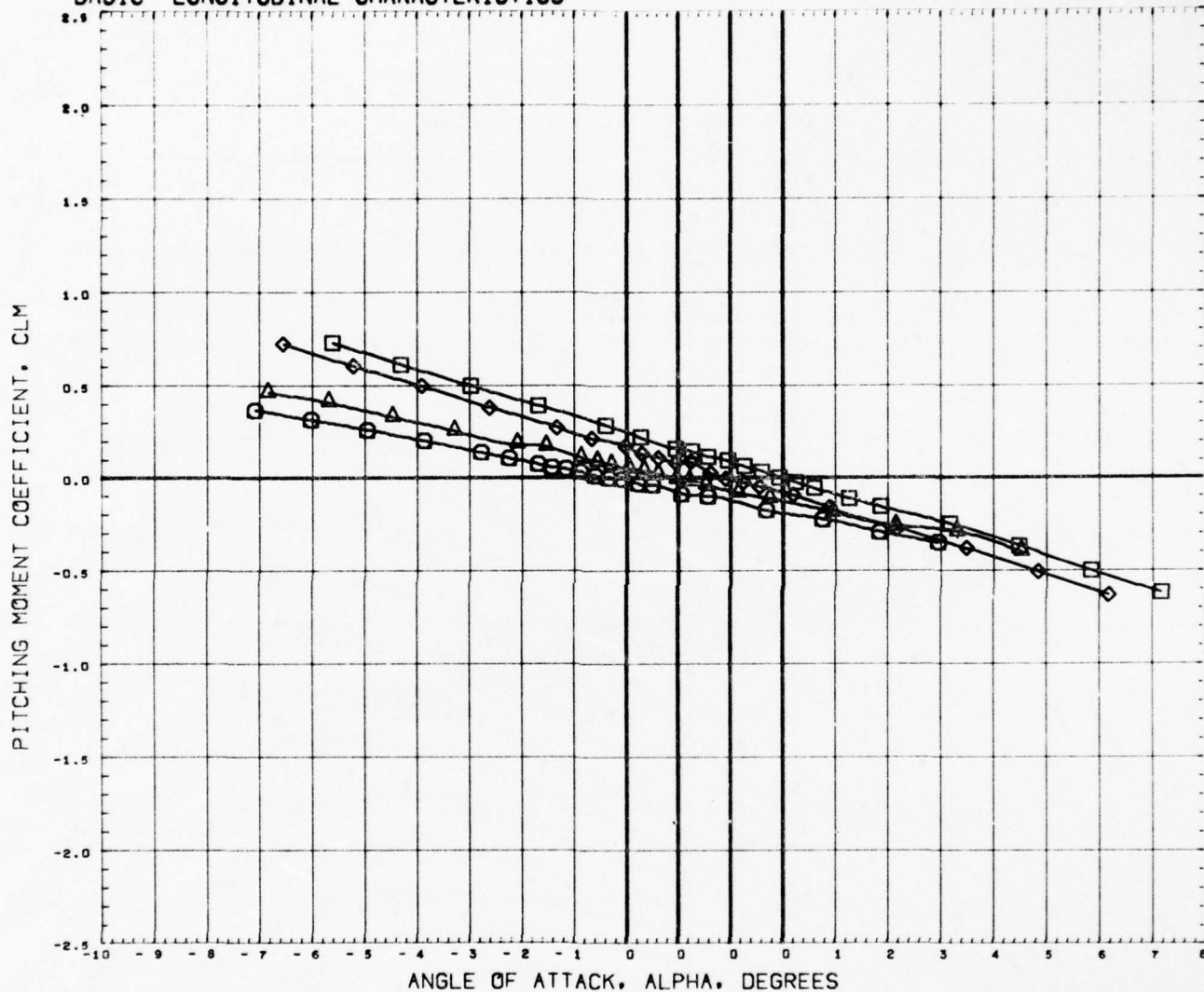

SYMBOL	MACH	PHI	PARAMETRIC VALUES	
○	0.499		0.000	M-LGTH 0.750
△	0.800			
◇	0.932			
□	0.996			

REFERENCE INFORMATION		
SREF	7.0686	50. IN.
LREF	3.0000	INCHES
BREF	3.0000	INCHES
XMRP	0.0000	INCHES
YMRP	0.0000	INCHES
ZMRP	0.0000	INCHES
SCALE	0.0000	NONE

REFERENCE FILE

AEDC TEST PWT-4T201 CONE-CYLINDER, N1M3

(RTAM03) 10 MAR 72 PAGE 11

BASIC LONGITUDINAL CHARACTERISTICS

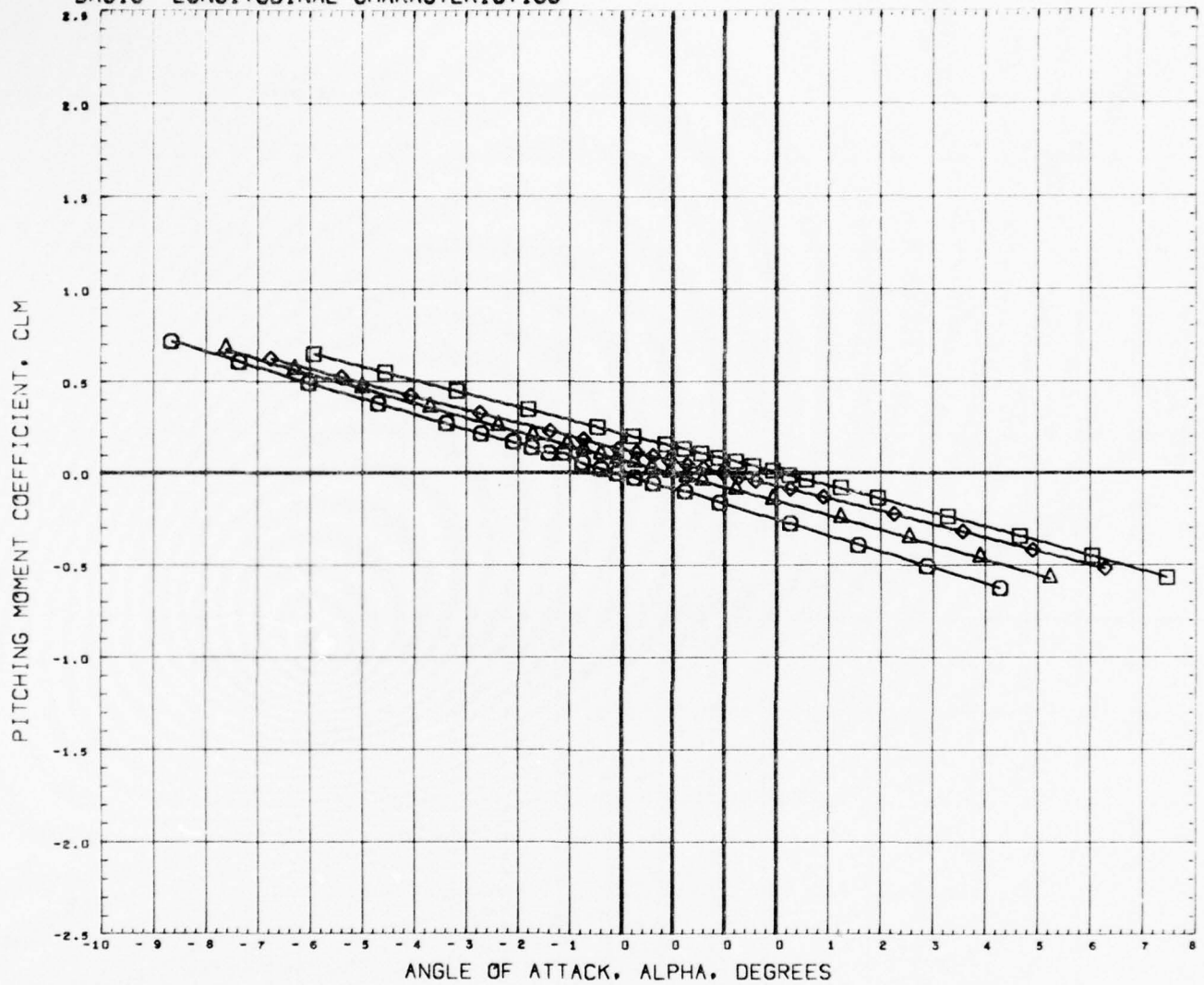

SYMBOL	MACH	PHI	PARAMETRIC VALUES	
○	1.051	0.000	M-LGTH	0.750
△	1.096			
◇	1.200			
□	1.300			

REFERENCE INFORMATION		
SREF	7.0686	sq. in.
LREF	3.0000	INCHES
BREF	3.0000	INCHES
XMRP	0.0000	INCHES
YMRP	0.0000	INCHES
ZMRP	0.0000	INCHES
SCALE	0.0000	NONE

REFERENCE FILE

AEDC TEST PWT-4T201 CONE-CYLINDER, N1M3

(RTAM03) 10 MAR 72

PAGE 12

BASIC LONGITUDINAL CHARACTERISTICS

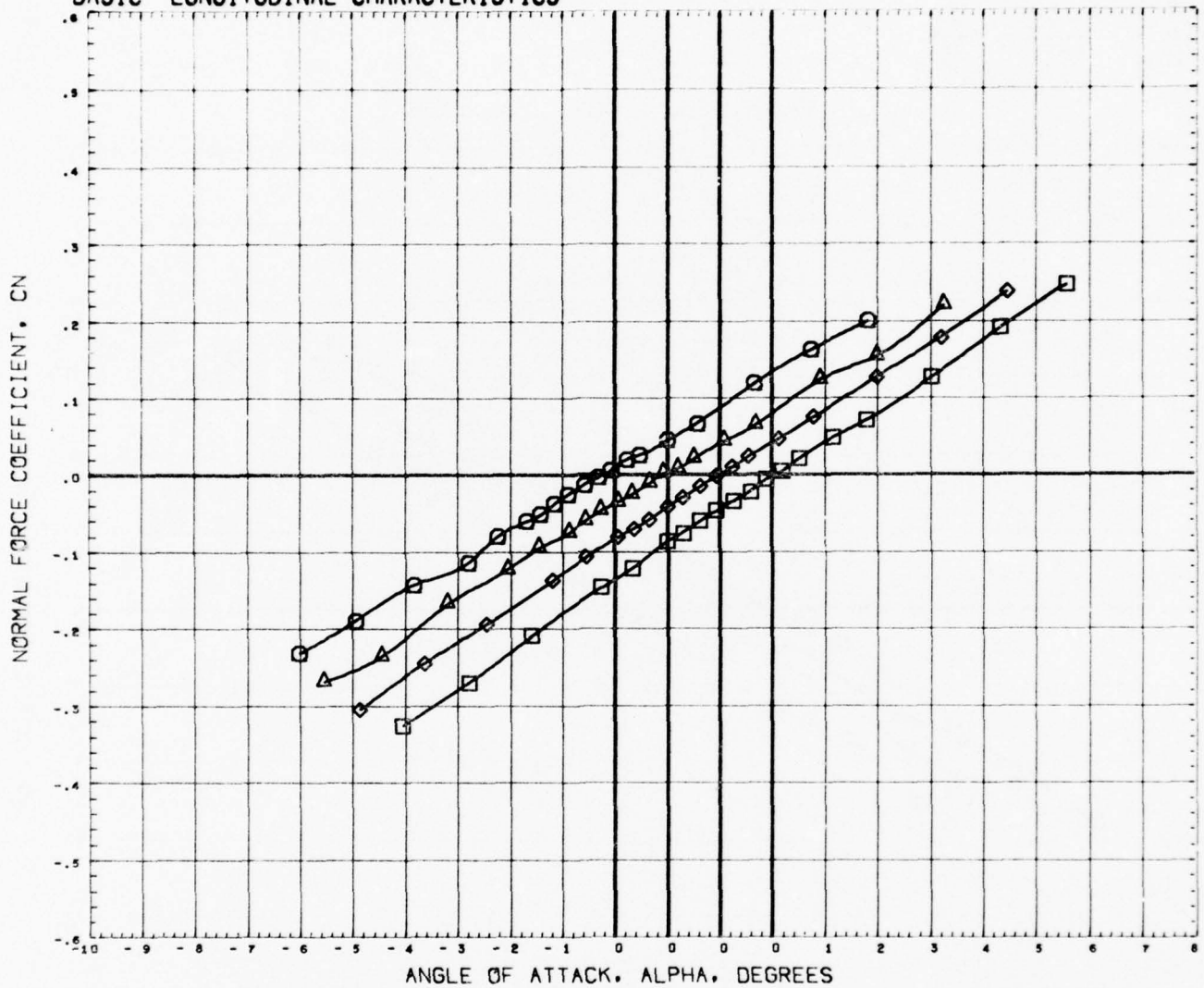

SYMBOL	MACH	PHI	PARAMETRIC VALUES	
○	0.502		0.000	M-LGTH 5.750
△	0.801			
◇	0.949			
□	0.998			

REFERENCE INFORMATION		
SREF	7.0686	SQ. IN.
LREF	3.0000	INCHES
BREF	3.0000	INCHES
XMRP	0.0000	INCHES
YMRP	0.0000	INCHES
ZMRP	0.0000	INCHES
SCALE	0.0000	NONE

REFERENCE FILE

BASIC LONGITUDINAL CHARACTERISTICS

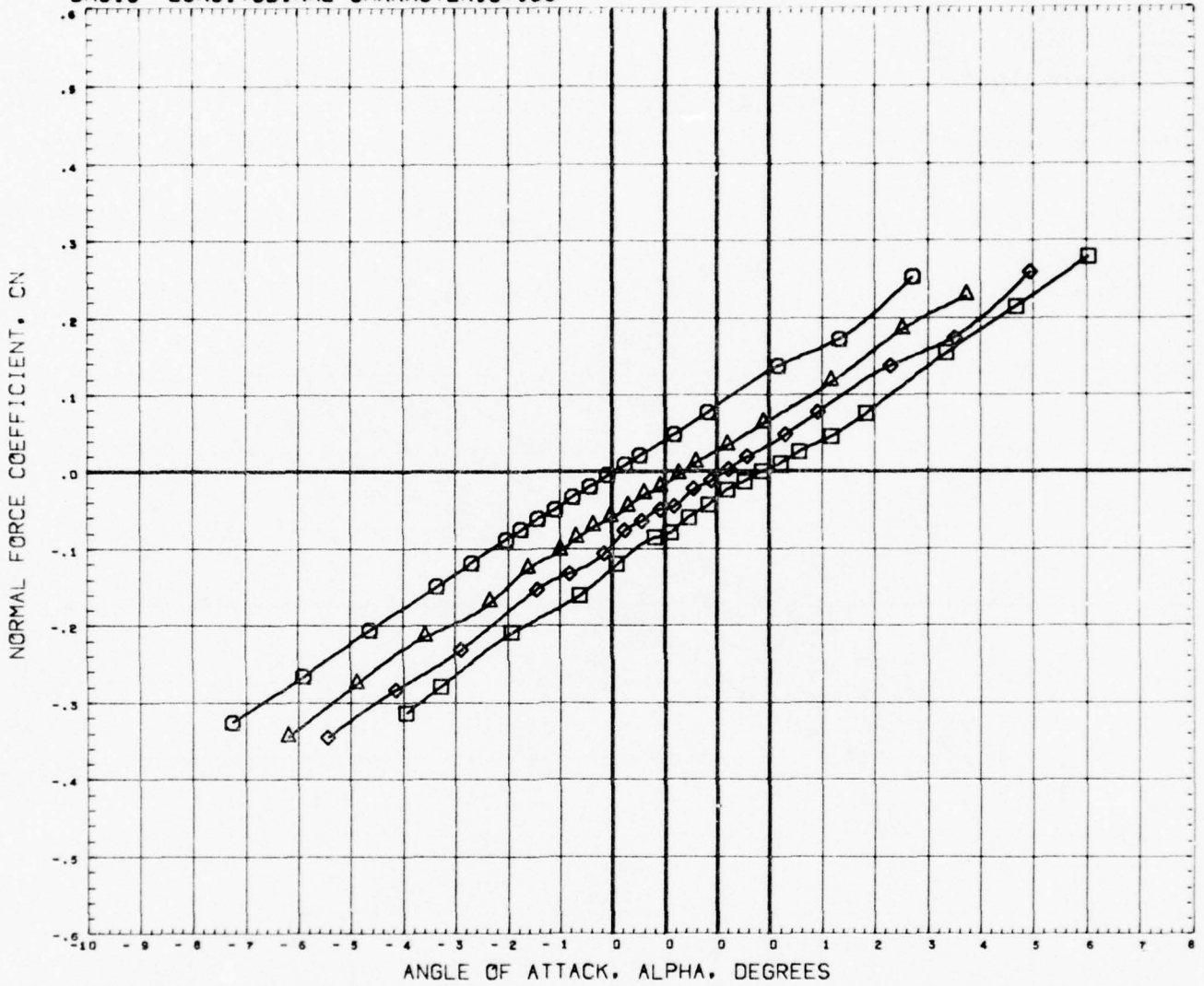

SYMBOL	MACH	PHI	PARAMETRIC VALUES	
○	1.046		0.000	M-LGTH 5.750
△	1.097			
◇	1.195			
□	1.297			

REFERENCE INFORMATION		
SREF	7.0686	50. IN.
LREF	3.0000	INCHES
BREF	3.0000	INCHES
XMRP	0.0000	INCHES
YMRP	0.0000	INCHES
ZMRP	0.0000	INCHES
SCALE	0.0000	NONE

REFERENCE FILE

AEDC TEST PWT-4T201 CONE-CYLINDER, N1M4

(RTAM04) 10 MAR 72

PAGE 14

BASIC LONGITUDINAL CHARACTERISTICS

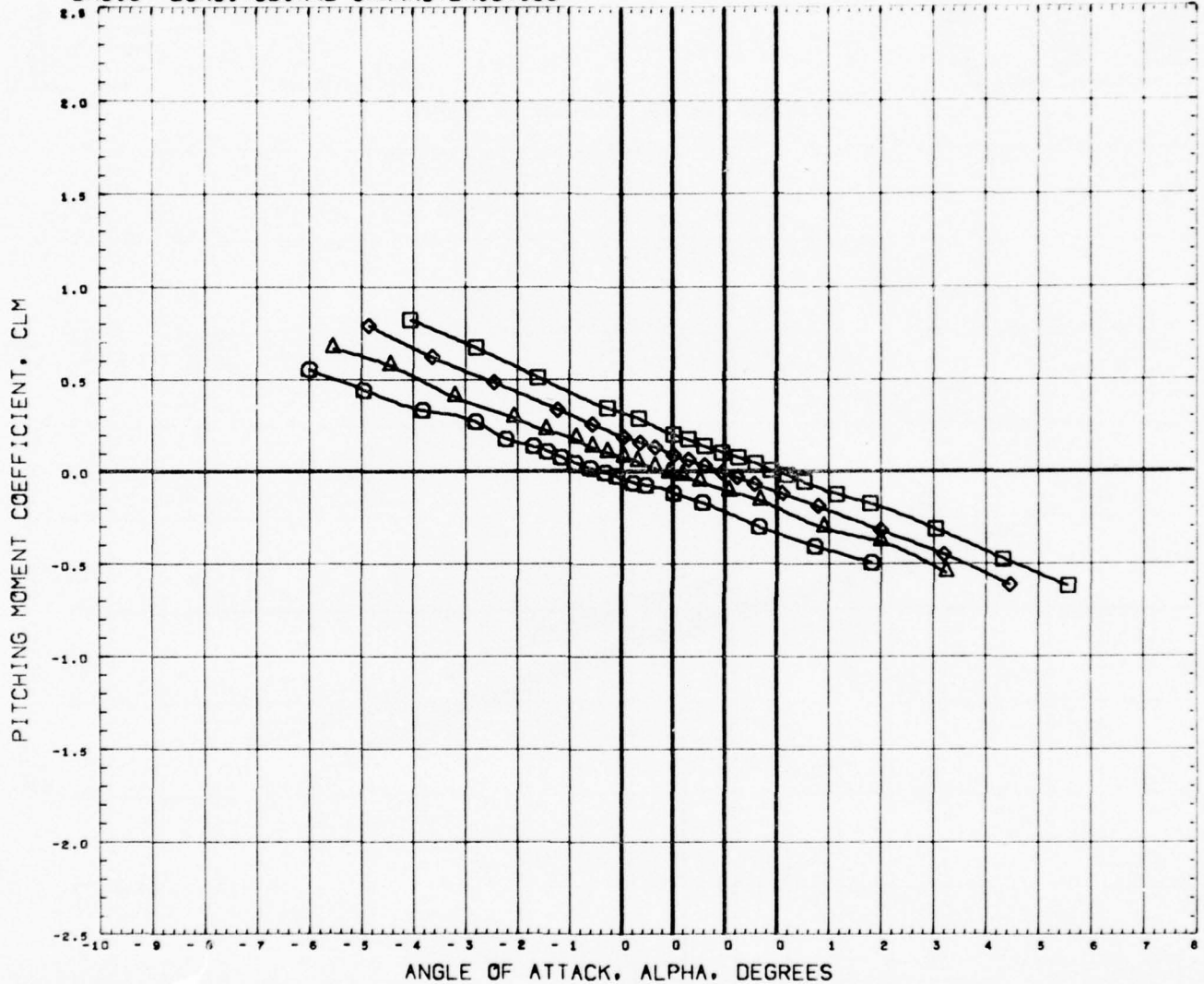

SYMBOL	MACH	PHI	PARAMETRIC VALUES	
○	0.502		0.000	M-LGTH 5.750
△	0.801			
◇	0.949			
□	0.998			

REFERENCE INFORMATION		
SREF	7.0686	50. IN.
LREF	3.0000	INCHES
BREF	3.0000	INCHES
XMRP	0.0000	INCHES
YMRP	0.0000	INCHES
ZMRP	0.0000	INCHES
SCALE	0.0000	NONE

REFERENCE FILE

AEDC TEST PWT-4T201 CONE-CYLINDER, N1M4

(RTAM04) 10 MAR 72

PAGE 15

BASIC LONGITUDINAL CHARACTERISTICS

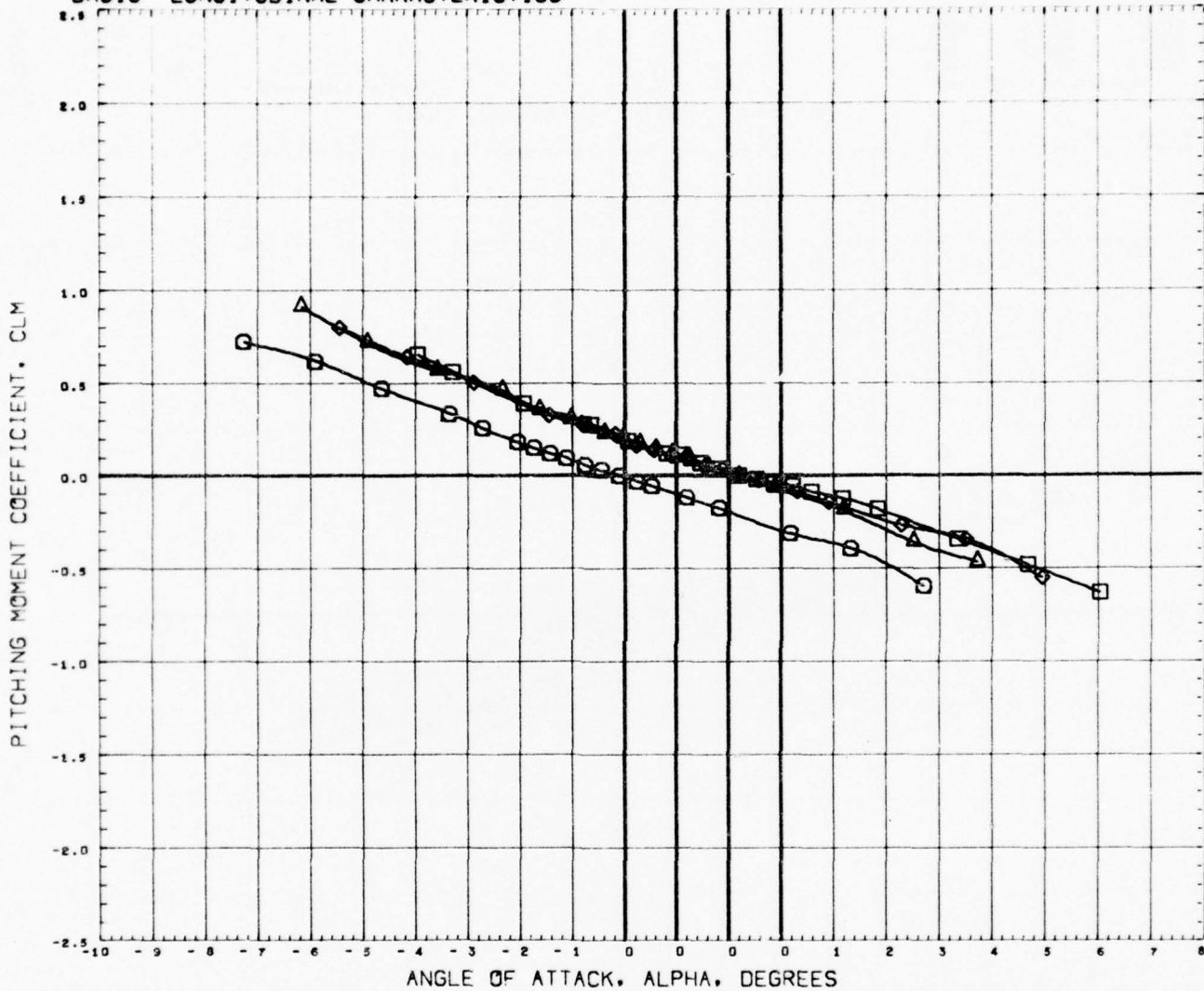

SYMBOL	MACH	PHI	PARAMETRIC VALUES	
○	1.046		0.000	M-LGTH 5.750
△	1.097			
◇	1.195			
□	1.297			

REFERENCE INFORMATION		
SREF	7.0686	SQ. IN.
LREF	3.0000	INCHES
BREF	3.0000	INCHES
XMRP	0.0000	INCHES
YMRP	0.0000	INCHES
ZMRP	0.0000	INCHES
SCALE	0.0000	NONE

REFERENCE FILE

AEDC TEST PWT-4T201 CONE-CYLINDER, N1M4

(RTAM04) 10 MAR 72 PAGE 16

BASIC LONGITUDINAL CHARACTERISTICS

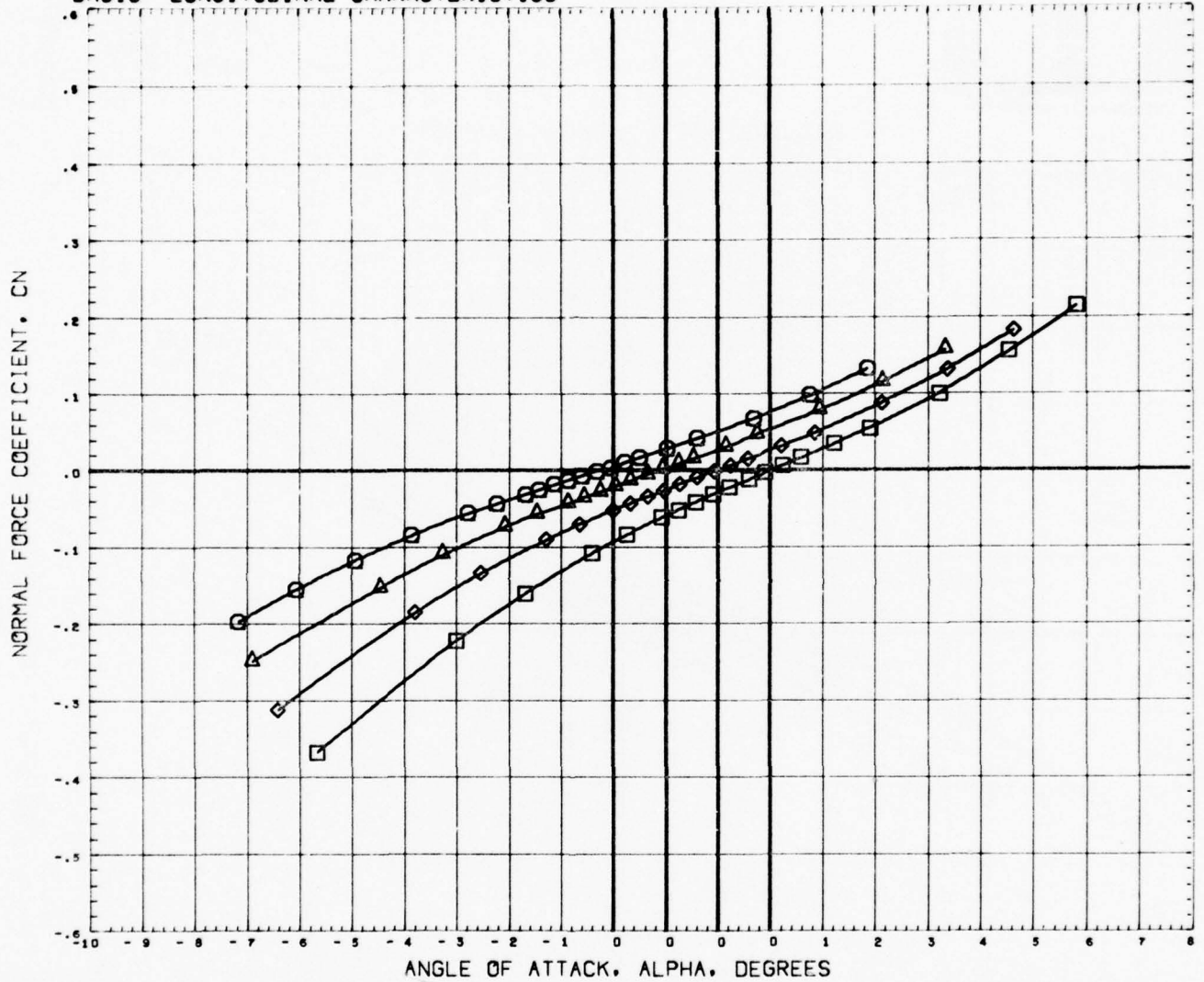

SYMBOL	MACH	PARAMETRIC VALUES				REFERENCE INFORMATION		
○	0.501	PHI	0.000	M-LGTH	2.250	SREF	7.0686	50. IN.
△	0.799	C-LGTH	5.000	C-DIA	0.400	LREF	3.0000	INCHES
◇	0.951					BREF	3.0000	INCHES
□	1.000					XMRP	0.0000	INCHES
						YMRP	0.0000	INCHES
						ZMRP	0.0000	INCHES
						SCALE	0.0000	NONE

REFERENCE FILE

AEDC TEST PWT-4T201 CONE-CYLINDER, N1M1C1

(RTAM05) 10 MAR 72

PAGE 17

BASIC LONGITUDINAL CHARACTERISTICS

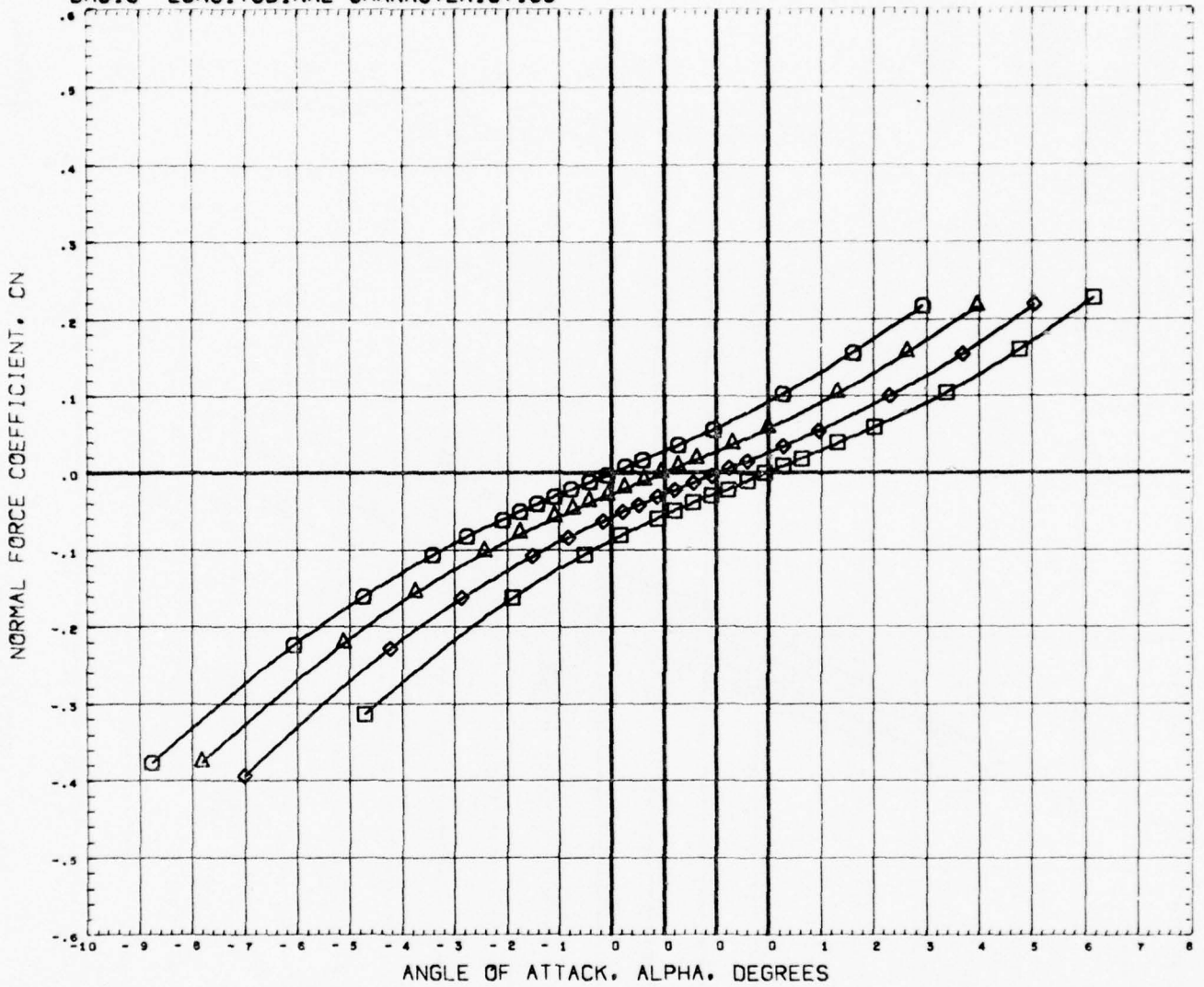

SYMBOL	MACH	PARAMETRIC VALUES			
○	1.053	PHI	0.000	M-LGTH	2.250
◇	1.099	C-LGTH	5.000	C-DIA	0.400
◇	1.200				
□	1.298				

REFERENCE INFORMATION		
SREF	7.0686	SQ. IN.
LREF	3.0000	INCHES
BREF	3.0000	INCHES
XMRP	0.0000	INCHES
YMRP	0.0000	INCHES
ZMRP	0.0000	INCHES
SCALE	0.0000	NONE

REFERENCE FILE

AEDC TEST PWT-4T201 CONE-CYLINDER, N1M1C1

(RTAM05) 10 MAR 72

PAGE 18

BASIC LONGITUDINAL CHARACTERISTICS

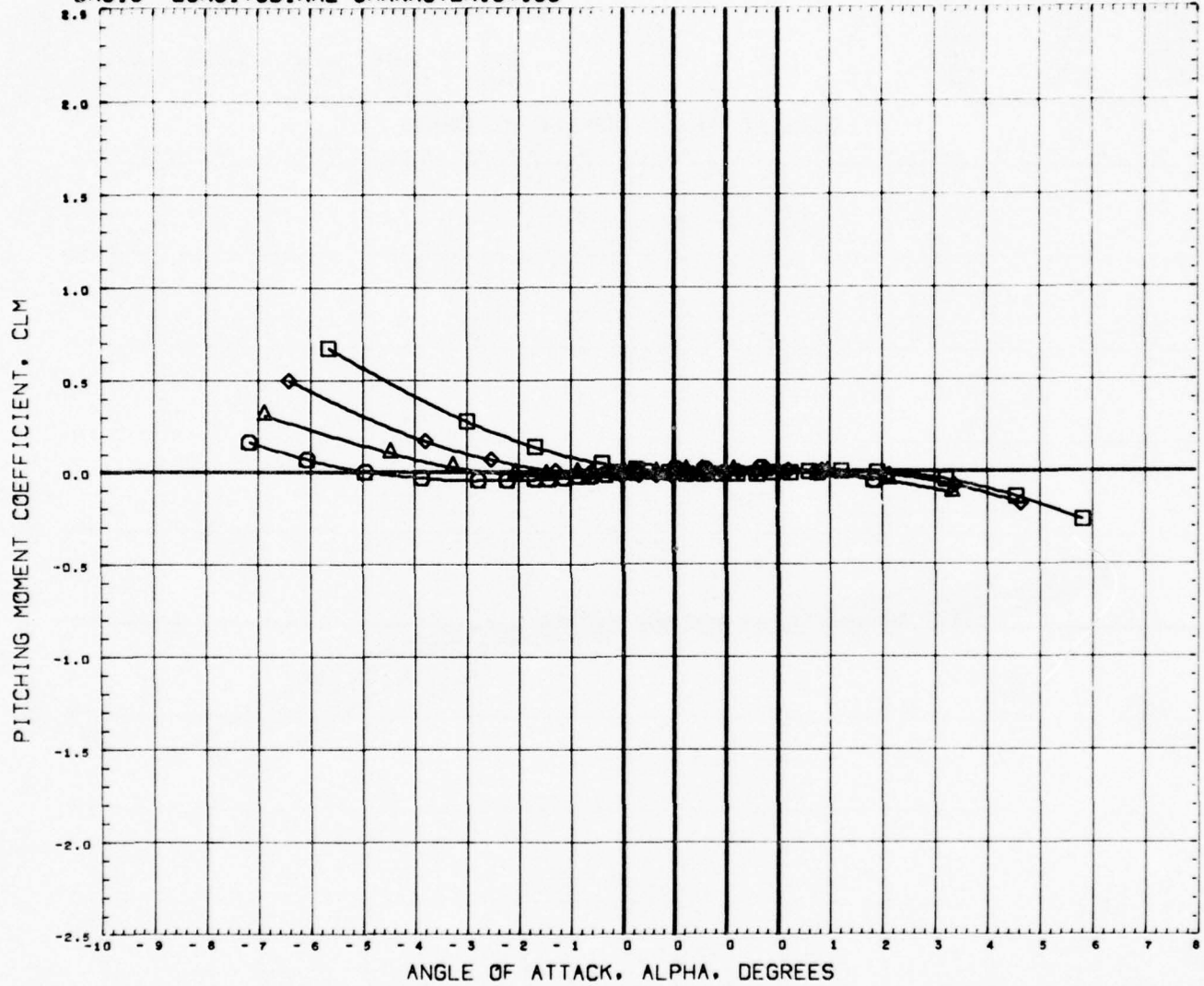

SYMBOL	MACH	PHI	PARAMETRIC VALUES		
○	0.501	0.000	M-LGTH	2.250	
△	0.799	C-LGTH	5.000	C-DIA	0.400
◇	0.951				
□	1.000				

REFERENCE INFORMATION		
SREF	7.0686	50. IN.
LREF	3.0000	INCHES
BREF	3.0000	INCHES
XMRP	0.0000	INCHES
YMRP	0.0000	INCHES
ZMRP	0.0000	INCHES
SCALE	0.0000	NONE

REFERENCE FILE

AEDC TEST PWT-4T201 CONE-CYLINDER, N1M1C1

(RTAM05) 10 MAR 72 PAGE 19

BASIC LONGITUDINAL CHARACTERISTICS

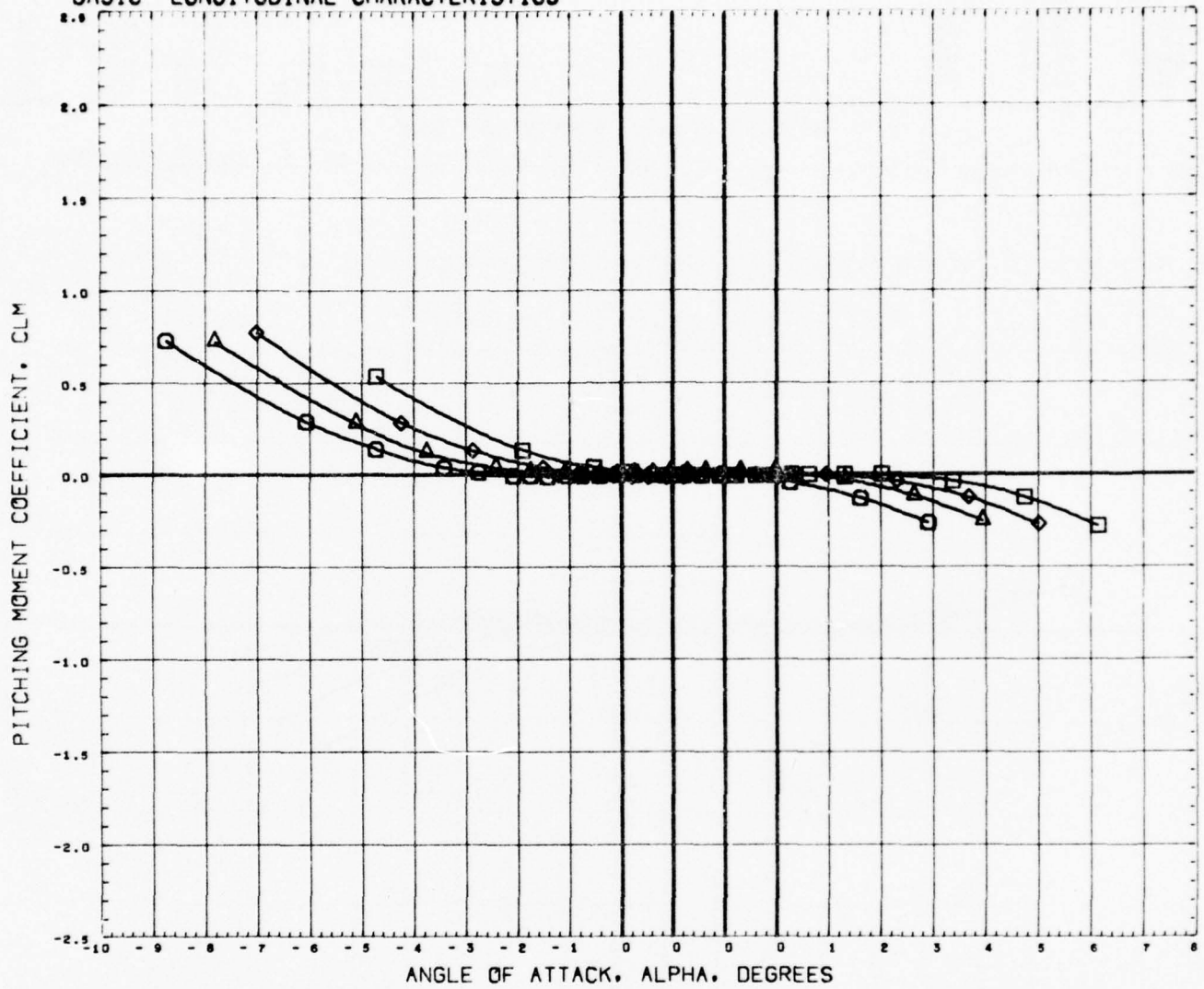

SYMBOL	MACH	PARAMETRIC VALUES				REFERENCE INFORMATION		
○	1.053	PHI	0.000	M-LGTH	2.250	SREF	7.0686	50. IN.
△	1.099	C-LGTH	5.000	C-DIA	0.400	LREF	3.0000	INCHES
◇	1.200					BREF	3.0000	INCHES
□	1.298					XMRP	0.0000	INCHES
						YMRP	0.0000	INCHES
						ZMRP	0.0000	INCHES
						SCALE	0.0000	NONE

REFERENCE FILE

AEDC TEST PWT-4T201 CONE-CYLINDER, N1M1C1

(RTAM05) 10 MAR 72

PAGE 20

BASIC LONGITUDINAL CHARACTERISTICS

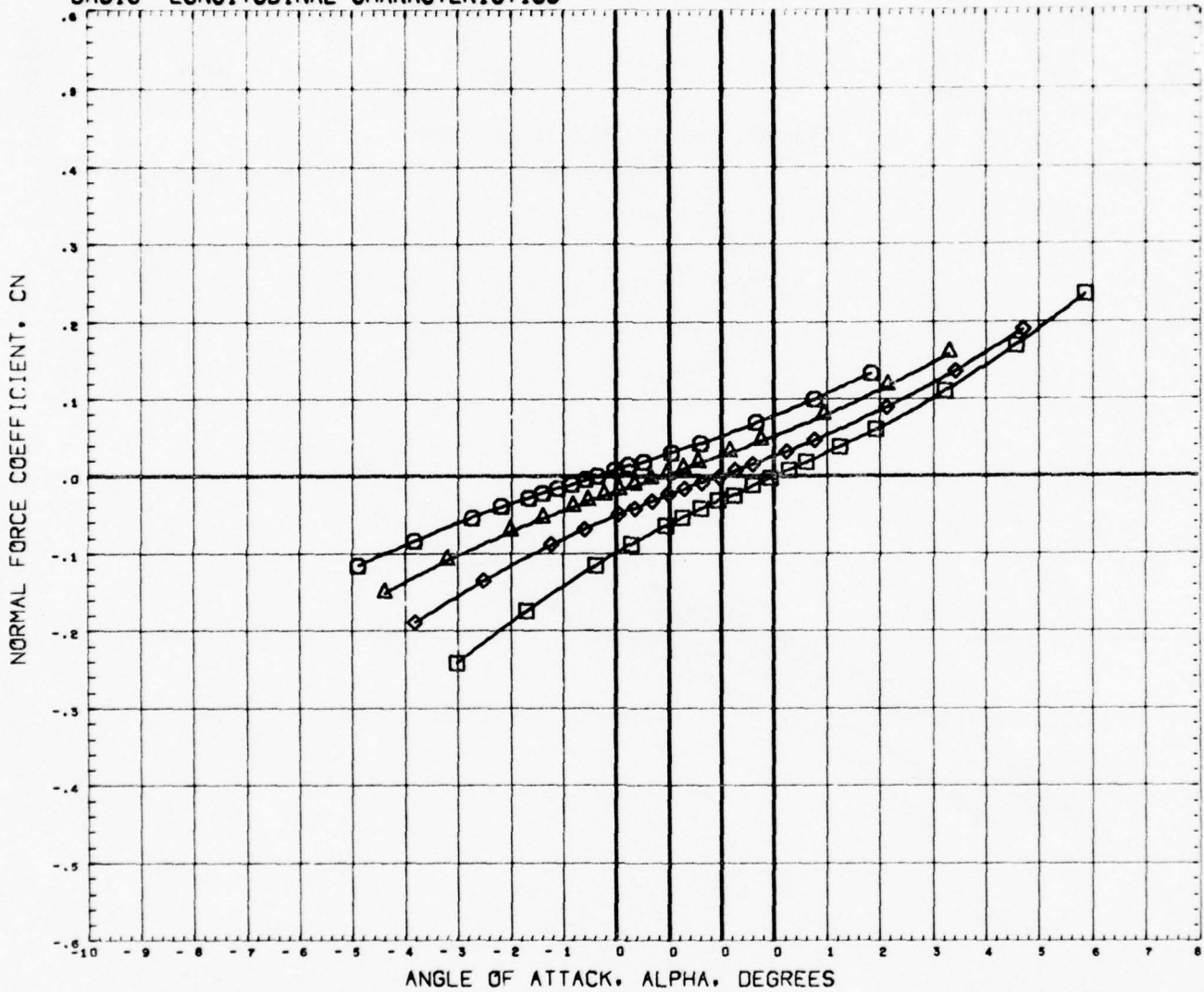

SYMBOL	MACH	PARAMETRIC VALUES				REFERENCE INFORMATION		
○	0.501	PHI	0.000	M-LGTH	1.500	SREF	7.0686	SQ. IN.
△	0.800	C-LGTH	5.000	C-DIA	0.400	LREF	3.0000	INCHES
◇	0.953					BREF	3.0000	INCHES
□	1.003					XMRP	0.0000	INCHES
						YMRP	0.0000	INCHES
						ZMRP	0.0000	INCHES
						SCALE	0.0000	NONE

DATA HIST. CODE *6

BASIC LONGITUDINAL CHARACTERISTICS

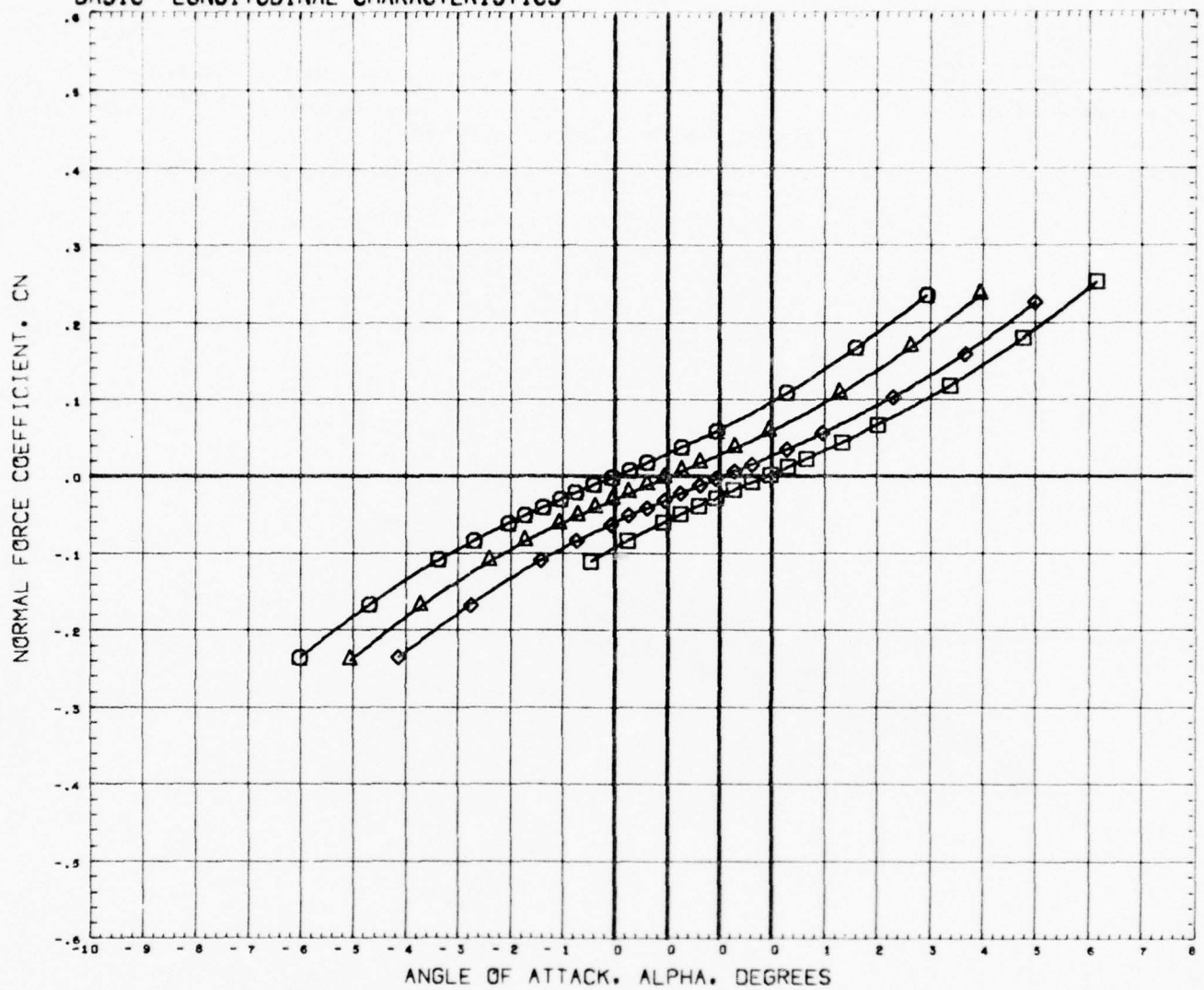

SYMBOL	MACH	PARAMETRIC VALUES				REFERENCE INFORMATION		
○	1.052	PHI	0.000	M-LGTH	1.500	SREF	7.0686	50. IN.
△	1.100	C-LGTH	5.000	C-DIA	0.400	LREF	3.0000	INCHES
◇	1.199					BREF	3.0000	INCHES
□	1.293					XMRP	0.0000	INCHES
						YMRP	0.0000	INCHES
						ZMRP	0.0000	INCHES
						SCALE	0.0000	NONE

DATA HIST. CODE #6

BASIC LONGITUDINAL CHARACTERISTICS

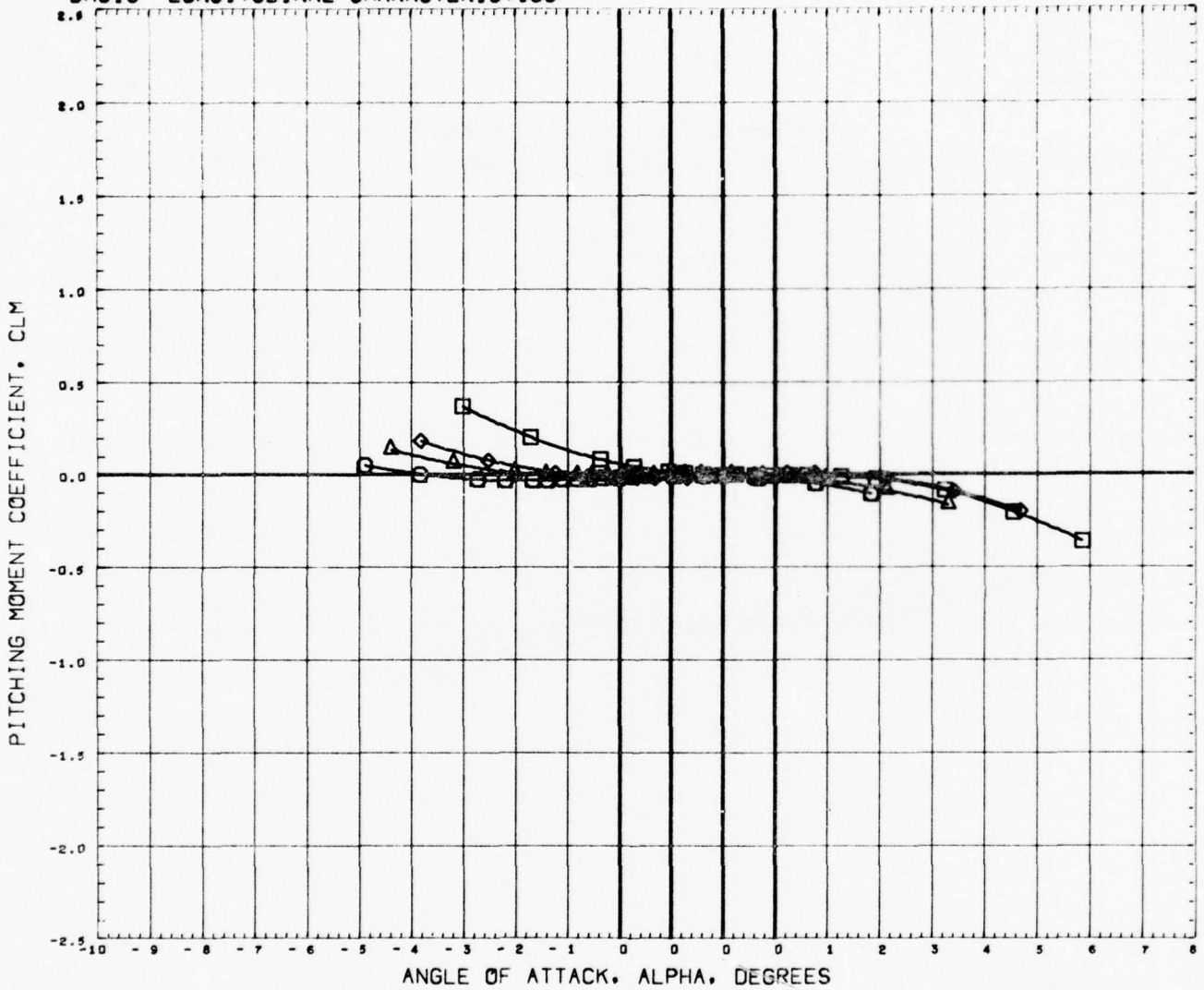

SYMBOL	MACH	PARAMETRIC VALUES			
○	0.501	PHI	0.000	M-LGTH	1.500
△	0.800	C-LGTH	5.000	C-DIA	0.400
◇	0.953				
□	1.003				

REFERENCE INFORMATION		
SREF	7.0686	50. IN.
LREF	3.0000	INCHES
BREF	3.0000	INCHES
XMRP	0.0000	INCHES
YMRP	0.0000	INCHES
ZMRP	0.0000	INCHES
SCALE	0.0000	NONE

DATA HIST. CODE *6

BASIC LONGITUDINAL CHARACTERISTICS

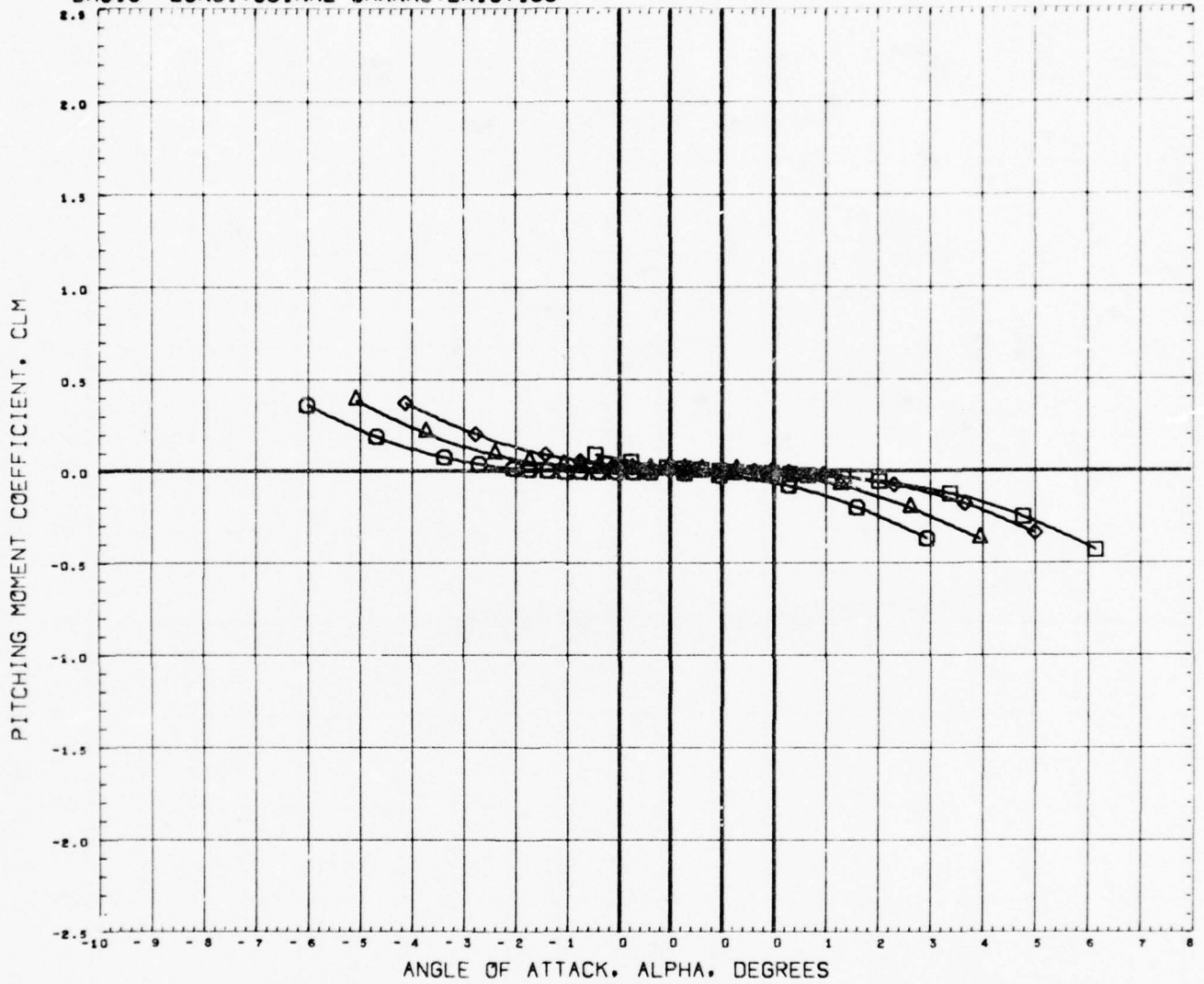

SYMBOL	MACH	PARAMETRIC VALUES				REFERENCE INFORMATION		
○	1.052	PHI	0.000	M-LGTH	1.500	SREF	7.0686	50. IN.
△	1.100	C-LGTH	5.000	C-DIA	0.400	LREF	3.0000	INCHES
◇	1.199					BREF	3.0000	INCHES
□	1.299					XMRP	0.0000	INCHES
						YMRP	0.0000	INCHES
						ZMRP	0.0000	INCHES
						SCALE	0.0000	NONE

DATA HIST. CODE *G

BASIC LONGITUDINAL CHARACTERISTICS

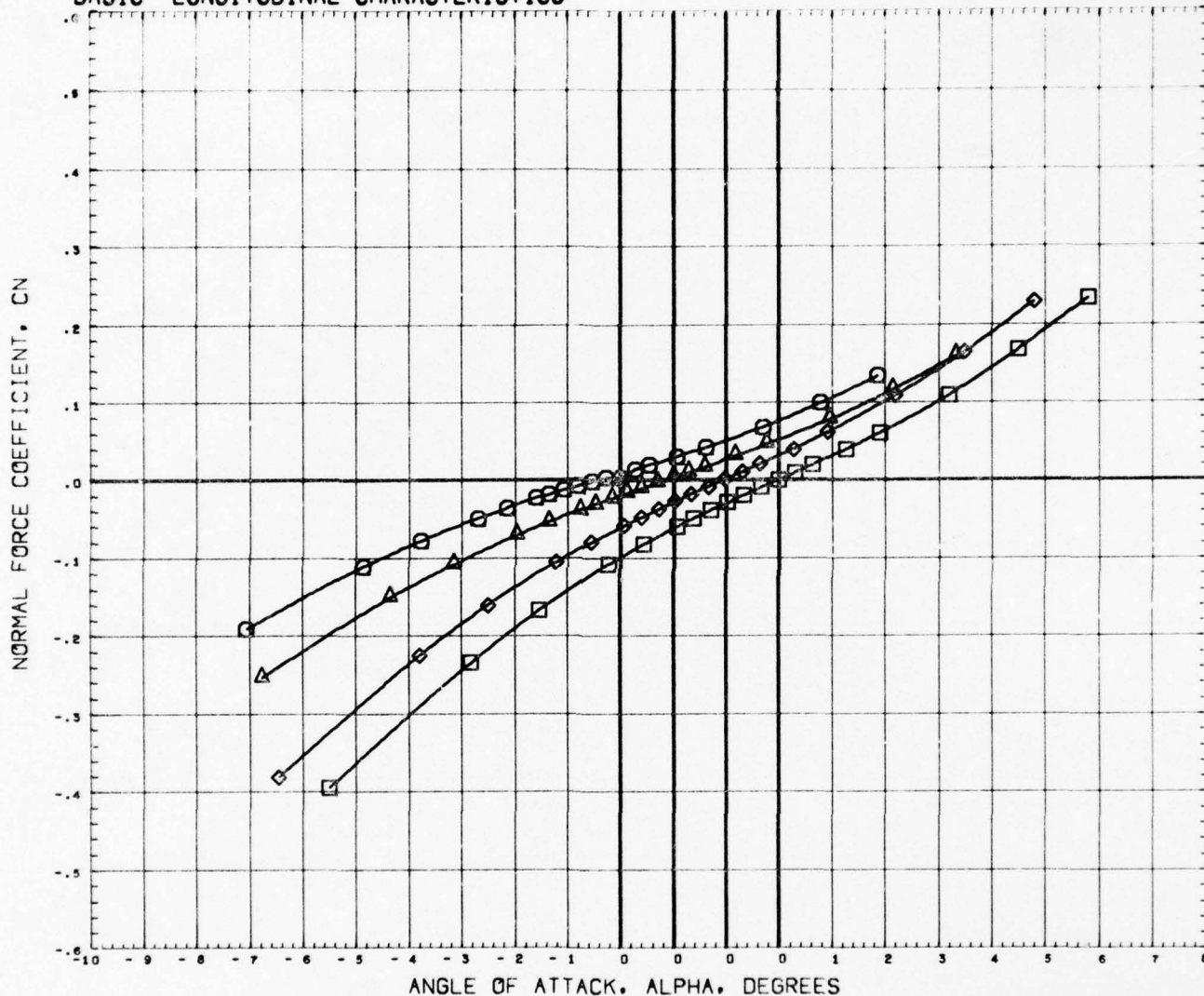

SYMBOL	MACH	PARAMETRIC VALUES				REFERENCE INFORMATION		
○	0.502	PHI	0.000	M-LGTH	0.750	SREF	7.0686	50. IN.
△	0.801	C-LGTH	5.000	C-DIA	0.400	LREF	3.0000	INCHES
◇	0.950					BREF	3.0000	INCHES
□	1.001					XMRP	0.0000	INCHES
						YMRP	0.0000	INCHES
						ZMRP	0.0000	INCHES
						SCALE	0.0000	NONE

REFERENCE FILE

AEDC TEST PWT-4T201 CONE-CYLINDER, N1M3C1

(RTAM07) 10 MAR 72 PAGE 25

BASIC LONGITUDINAL CHARACTERISTICS

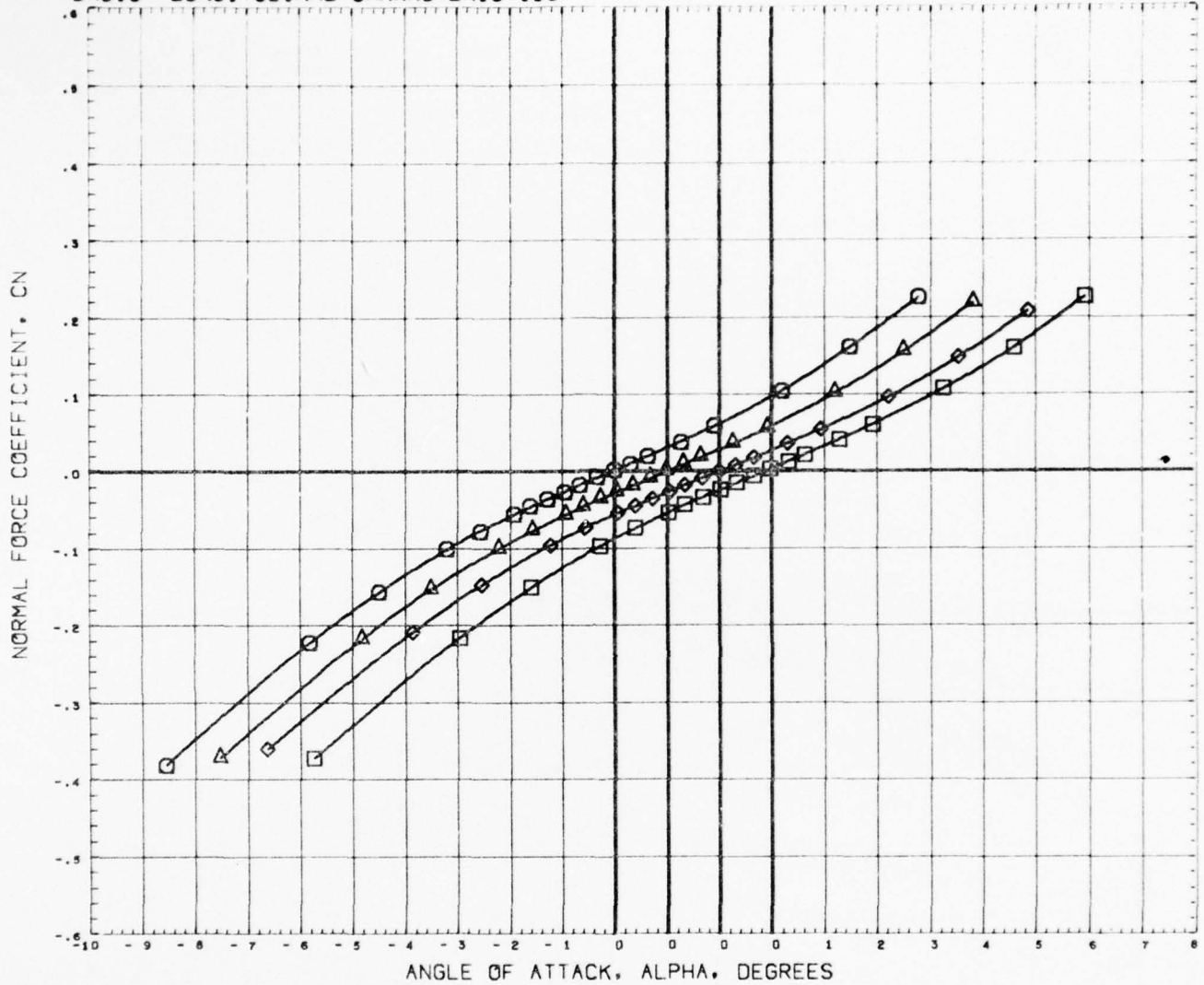

SYMBOL	MACH	PARAMETRIC VALUES				REFERENCE INFORMATION		
○	1.048	PHI	0.000	M-LGTH	0.750	SREF	7.0686	SQ. IN.
△	1.101	C-LGTH	5.000	C-DIA	0.400	LREF	3.0000	INCHES
◇	1.199					BREF	3.0000	INCHES
□	1.301					XMRP	0.0000	INCHES
						YMRP	0.0000	INCHES
						ZMRP	0.0000	INCHES
						SCALE	0.0000	NONE

REFERENCE FILE

AEDC TEST PWT-4T201 CONE-CYLINDER, N1M3C1

(RTAM07) 10 MAR 72

PAGE 26

BASIC LONGITUDINAL CHARACTERISTICS

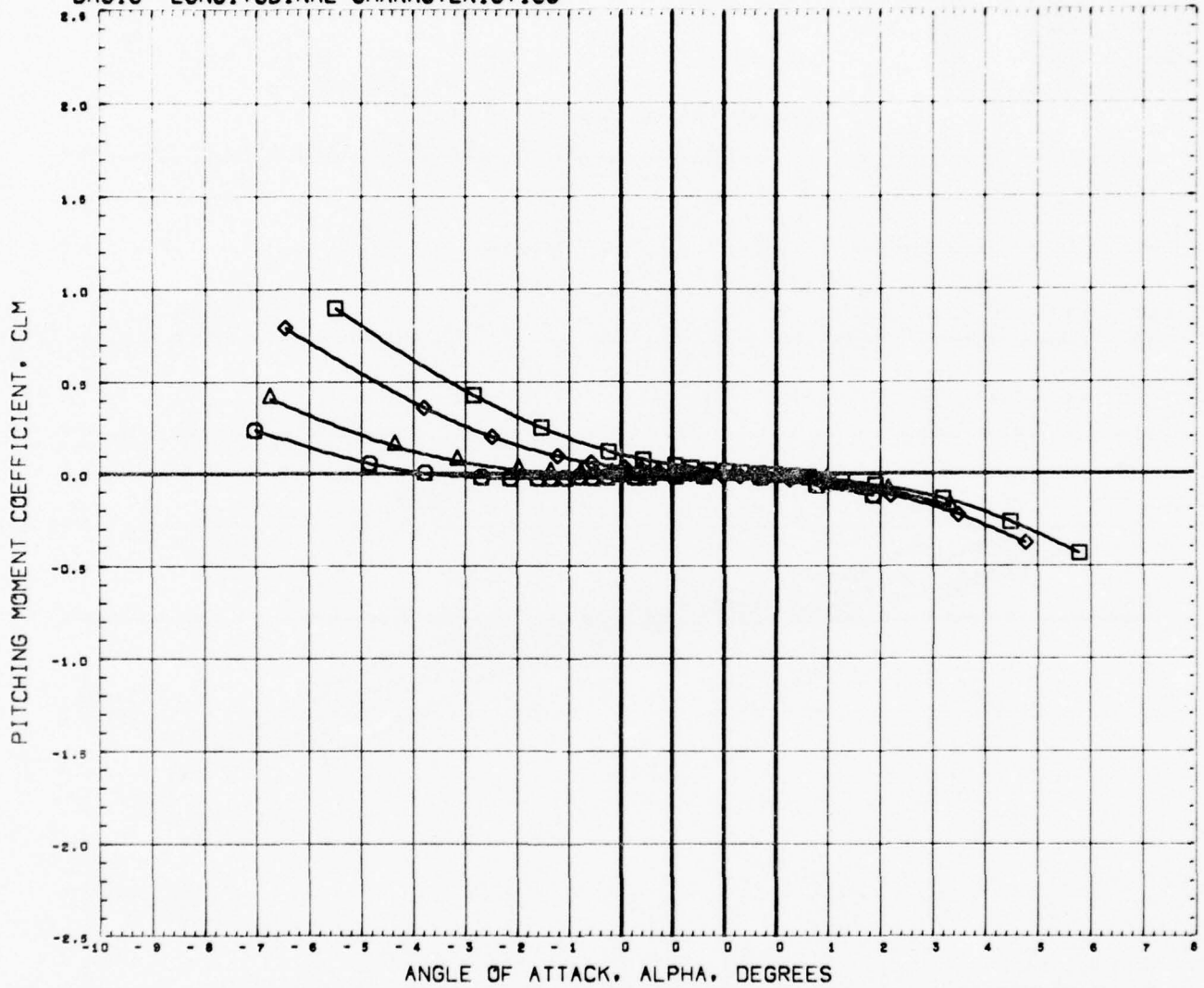

SYMBOL		MACH	PARAMETRIC VALUES			REFERENCE INFORMATION			
○		0.502	PHI	0.000	M-LGTH	0.750	SREF	7.0686	SQ. IN.
△		0.801	C-LGTH	5.000	C-DIA	0.400	LREF	3.0000	INCHES
◇		0.950					BREF	3.0000	INCHES
□		1.001					XMRP	0.0000	INCHES
							YMRP	0.0000	INCHES
							ZMRP	0.0000	INCHES
							SCALE	0.0000	NONE

REFERENCE FILE

AEDC TEST PWT-4T201 CONE-CYLINDER, N1M3C1

(RTAM07) 10 MAR 72

PAGE 27

BASIC LONGITUDINAL CHARACTERISTICS

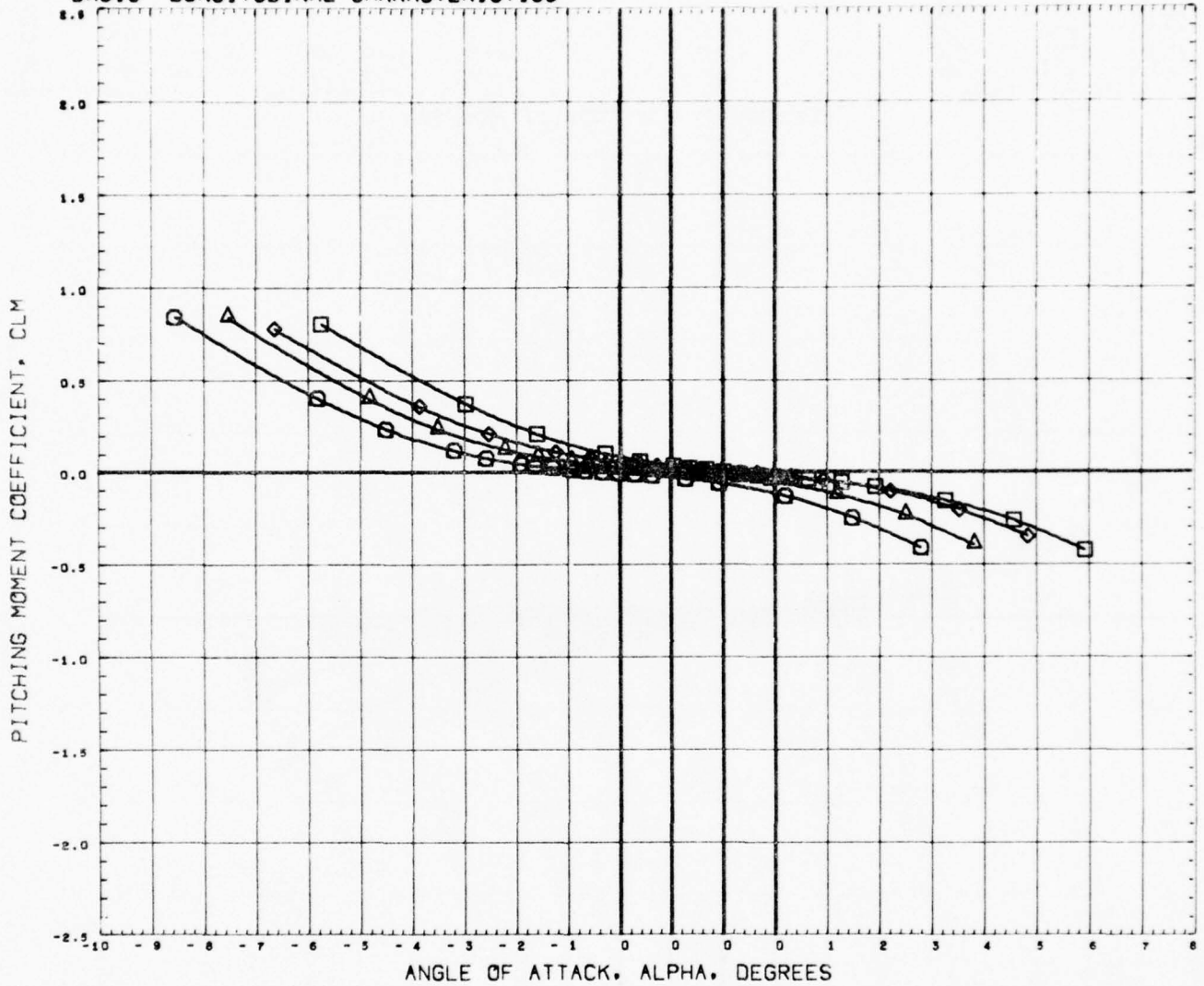

SYMBOL	MACH	PARAMETRIC VALUES				REFERENCE INFORMATION		
○	1.048	PHI	0.000	M-LGTH	0.750	SREF	7.0686	SQ. IN.
◇	1.101	C-LGTH	5.000	C-DIA	0.400	LREF	3.0000	INCHES
◇	1.199					BREF	3.0000	INCHES
□	1.301					XMRP	0.0000	INCHES
						YMRP	0.0000	INCHES
						ZMRP	0.0000	INCHES
						SCALE	0.0000	NONE

REFERENCE FILE

AEDC TEST PWT-4T201 CONE-CYLINDER, N1M3C1

(RTAM07) 10 MAR 72

PAGE 28

BASIC LONGITUDINAL CHARACTERISTICS

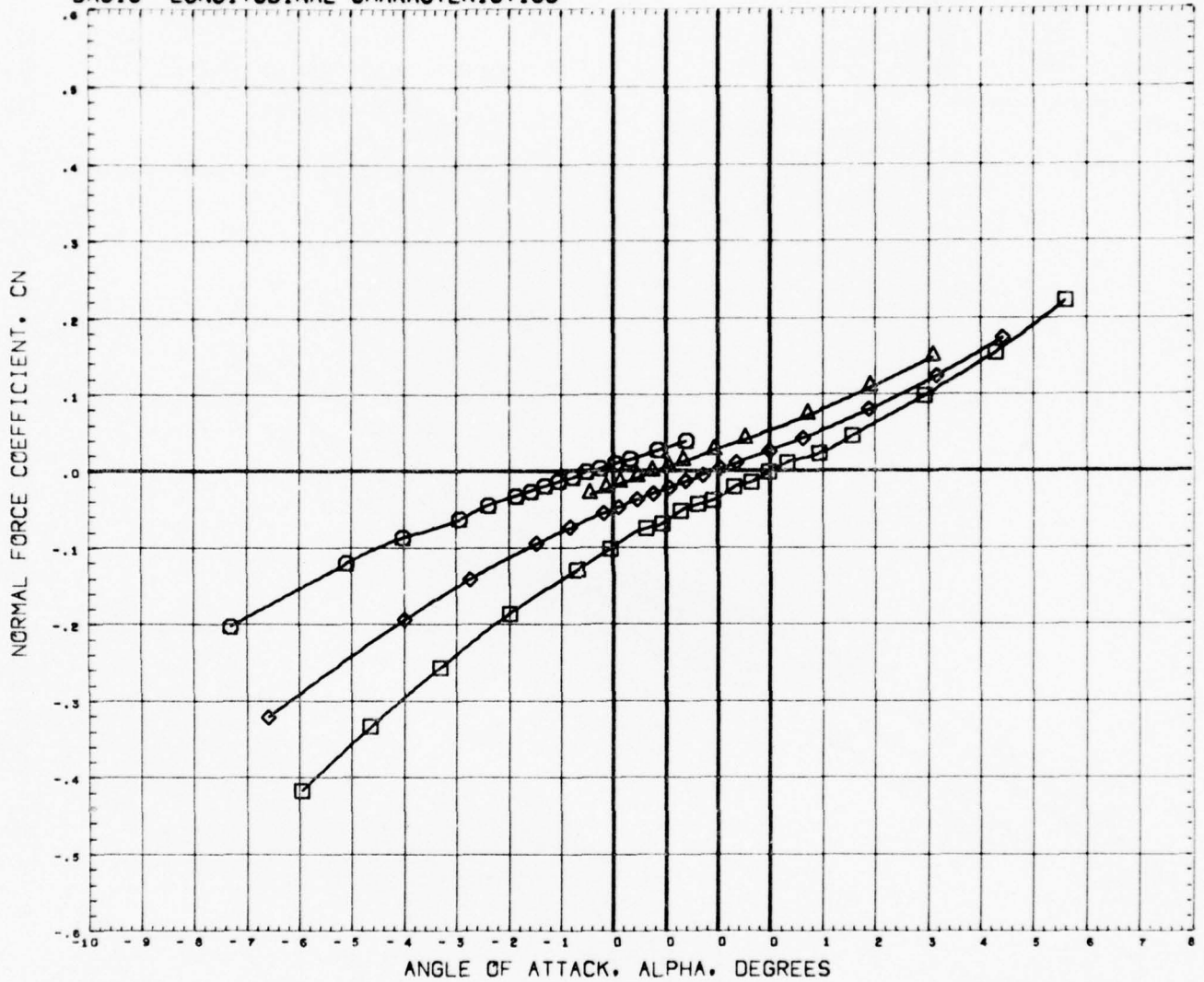

SYMBOL	MACH	PARAMETRIC VALUES				REFERENCE INFORMATION	
○	0.500	PHI	0.000	M-LGTH	1.500	SREF	7.0686 SQ. IN.
△	0.797	C-LGTH	5.000	C-DIA	0.400	LREF	3.0000 INCHES
◇	0.947					BREF	3.0000 INCHES
□	1.000					YMRP	0.0000 INCHES
						ZMRP	0.0000 INCHES
						SCALE	0.0000 NONE

REFERENCE FILE

AEDC TEST PWT-4T201 CONE-CYLINDER, N1M2B1C1

(RTA103)

10 MAR 72

PAGE

29

BASIC LONGITUDINAL CHARACTERISTICS

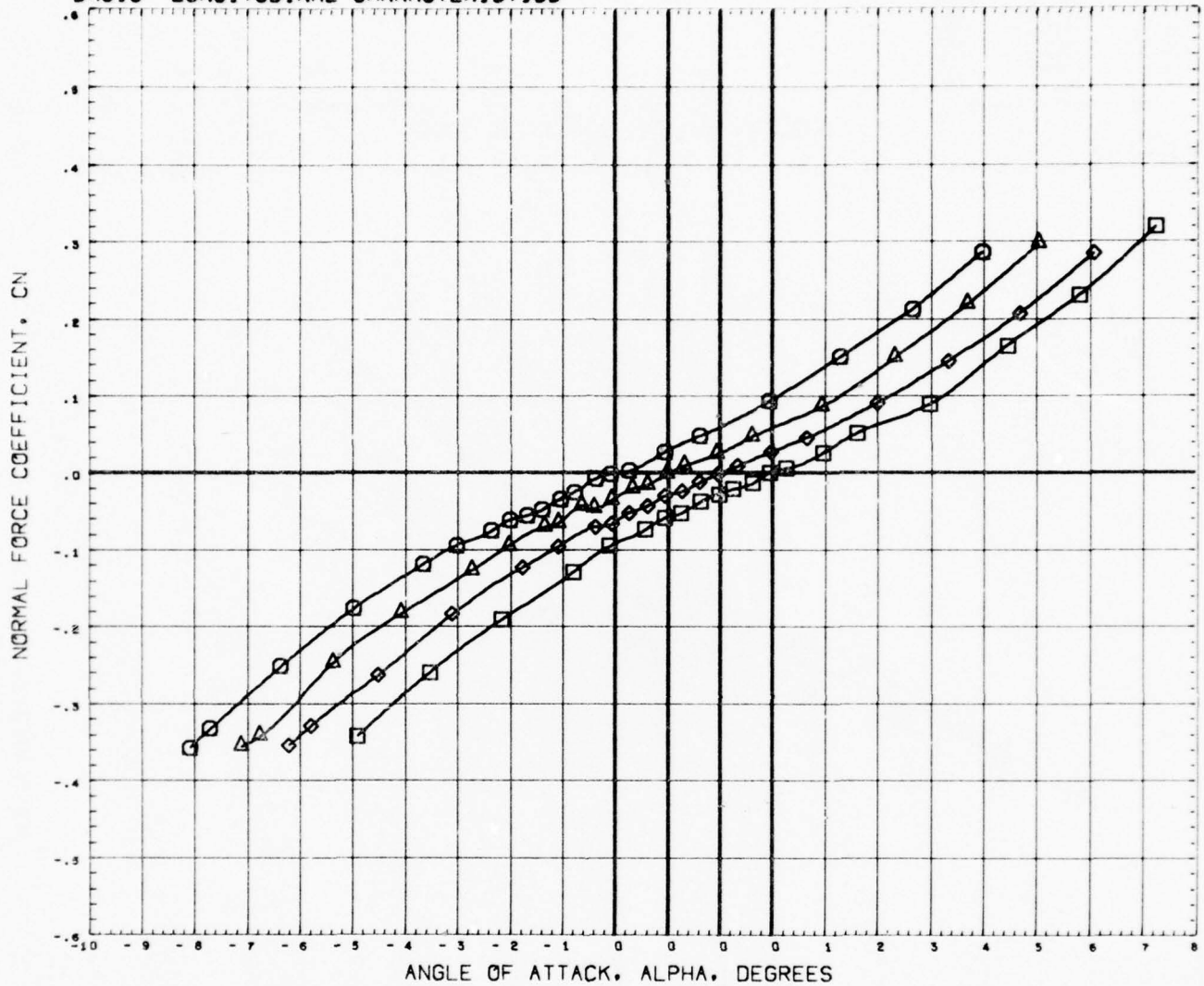

SYMBOL	MACH	PARAMETRIC VALUES			
○	1.048	PHI	0.000	M-LGTH	1.500
△	1.099	C-LGTH	5.000	C-DIA	0.400
◇	1.199				
□	1.300				

REFERENCE INFORMATION		
SREF	7.0686	50 IN.
LREF	3.0000	INCHES
BREF	3.0000	INCHES
XHRP	0.0000	INCHES
YHRP	0.0000	INCHES
ZHRP	0.0000	INCHES
SCALE	0.0000	NONE

REFERENCE FILE

AEDC TEST PWT-4T201 CONE-CYLINDER, N1M2B1C1

(RTAM08) 10 MAR 72

PAGE 30

BASIC LONGITUDINAL CHARACTERISTICS

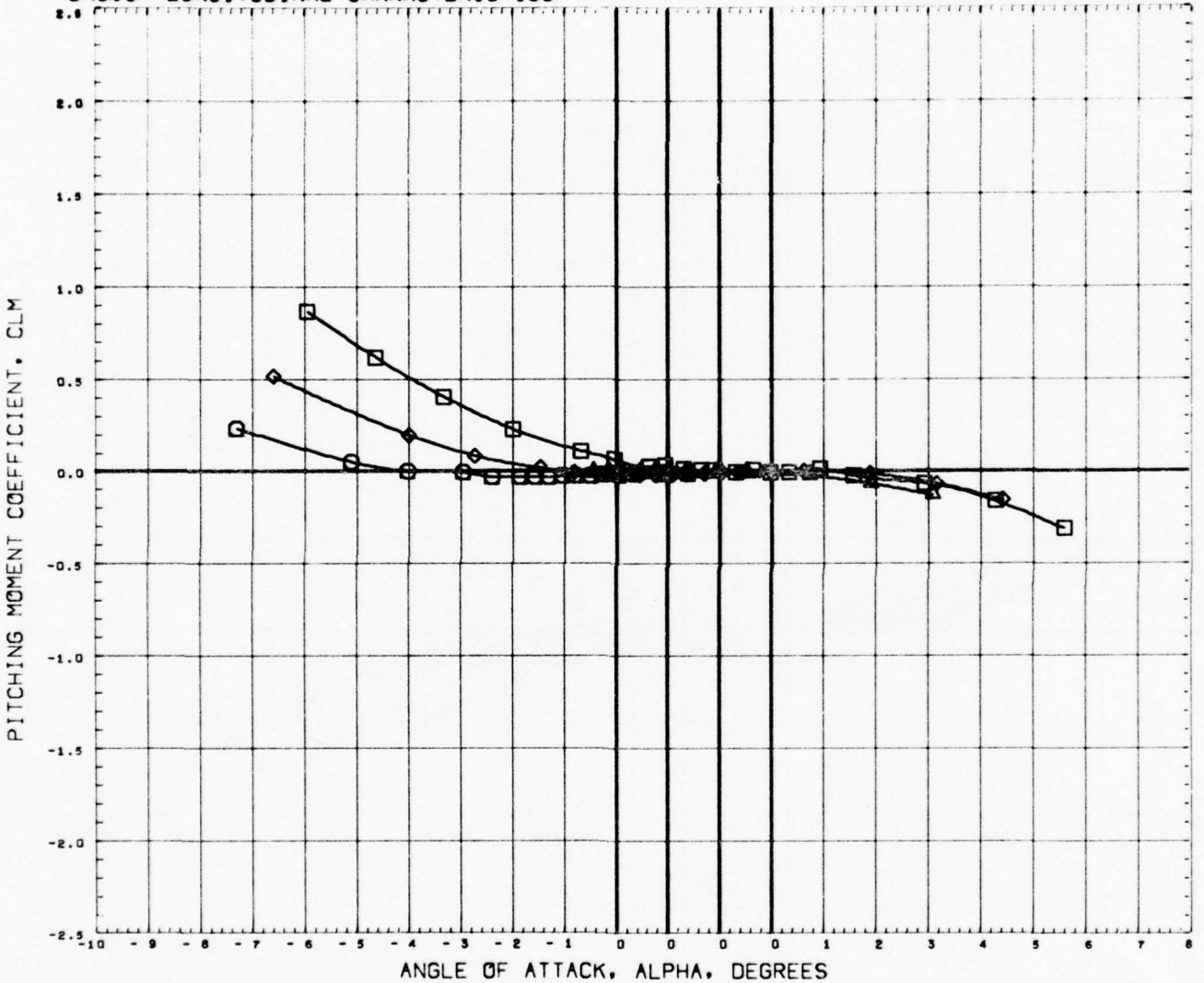

SYMBOL	MACH	PARAMETRIC VALUES				REFERENCE INFORMATION		
○	0.500	PHI	0.000	M-LGTH	1.500	SREF	7.0686	50. IN.
◇	0.797	C-LGTH	5.000	C-DIA	0.400	LREF	3.0000	INCHES
◇	0.947					BREF	3.0000	INCHES
□	1.000					XMRP	0.0000	INCHES
						YMRP	0.0000	INCHES
						ZMRP	0.0000	INCHES
						SCALE	0.0000	NONE

REFERENCE FILE

BASIC LONGITUDINAL CHARACTERISTICS

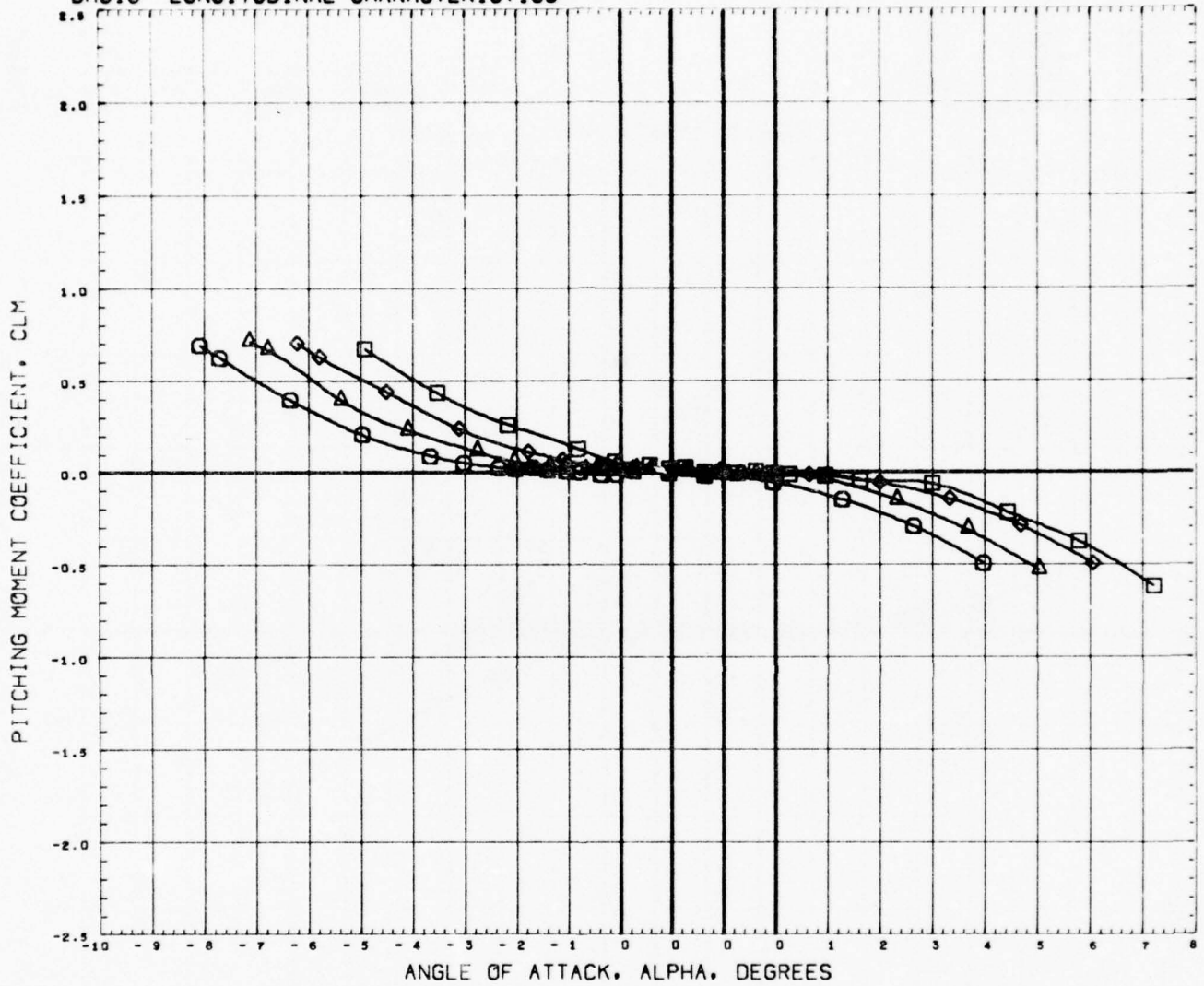

SYMBOL	MACH	PARAMETRIC VALUES				REFERENCE INFORMATION		
○	1.048	PHI	0.000	M-LGTH	1.500	SREF	7.0686	SQ. IN.
△	1.099	C-LGTH	5.000	C-DIA	0.400	LREF	3.0000	INCHES
◇	1.199					BREF	3.0000	INCHES
□	1.300					XMRP	0.0000	INCHES
						YMRP	0.0000	INCHES
						ZMRP	0.0000	INCHES
						SCALE	0.0000	NONE

REFERENCE FILE

AEDC TEST PWT-4T201 CONE-CYLINDER, N1M2B1C1

(RTAM08) 10 MAR 72

PAGE 32

BASIC LONGITUDINAL CHARACTERISTICS

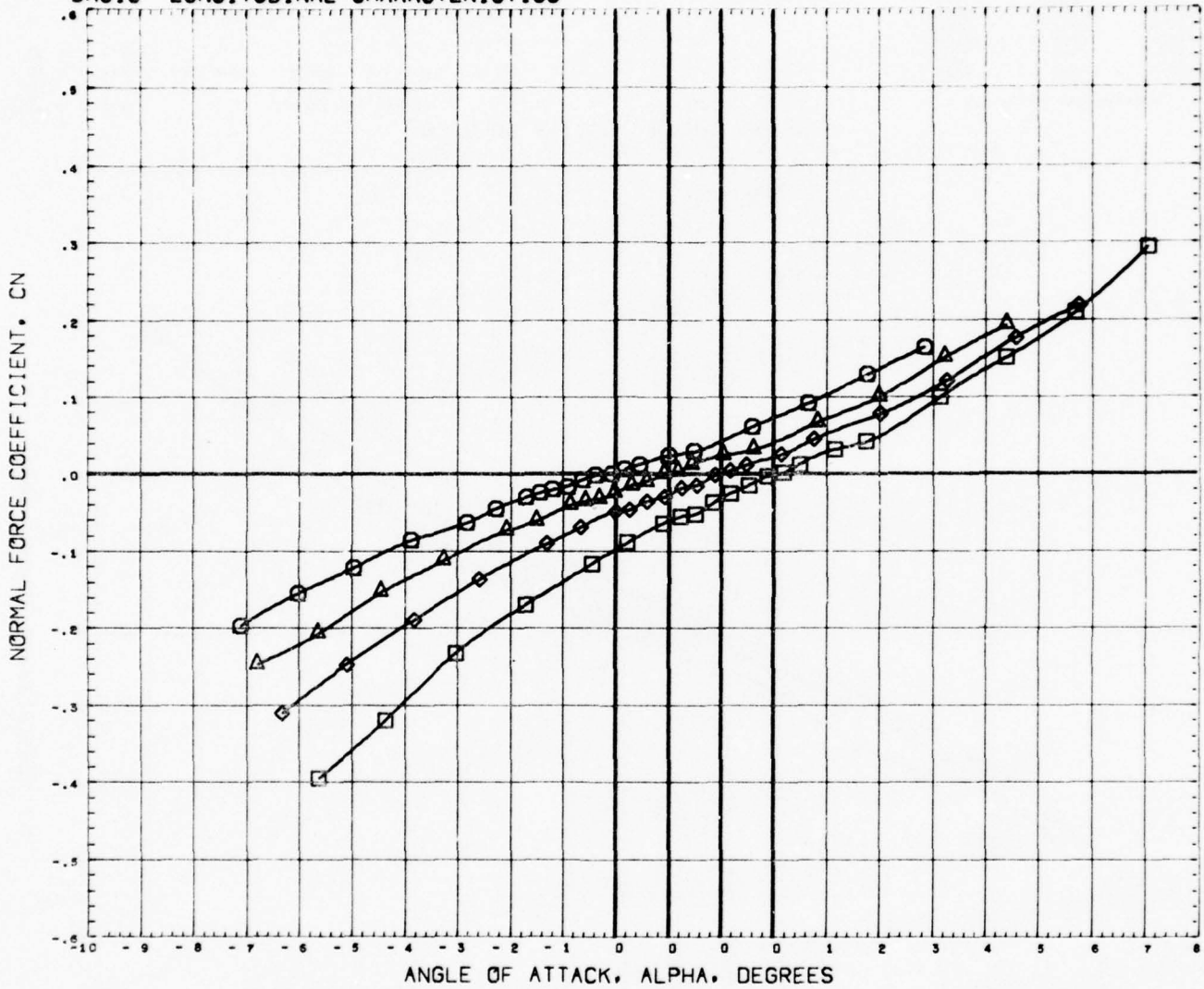

SYMBOL
 ○
 △
 ◇
 □

MACH
 0.500
 0.801
 0.948
 0.999

PARAMETRIC VALUES

PHI 0.000 M-LGTH 1.500
 C-LGTH 5.000 C-DIA 0.500

REFERENCE INFORMATION

SREF 7.0686 SQ. IN.
 LREF 3.0000 INCHES
 BREF 3.0000 INCHES
 XMRP 0.0000 INCHES
 YMRP 0.0000 INCHES
 ZMRP 0.0000 INCHES
 SCALE 0.0000 NONE

REFERENCE FILE

AEOC TEST PWT-4T201 CONE-CYLINDER, N1M2C2

(RTAM10) 10 MAR 72

PAGE 33

BASIC LONGITUDINAL CHARACTERISTICS

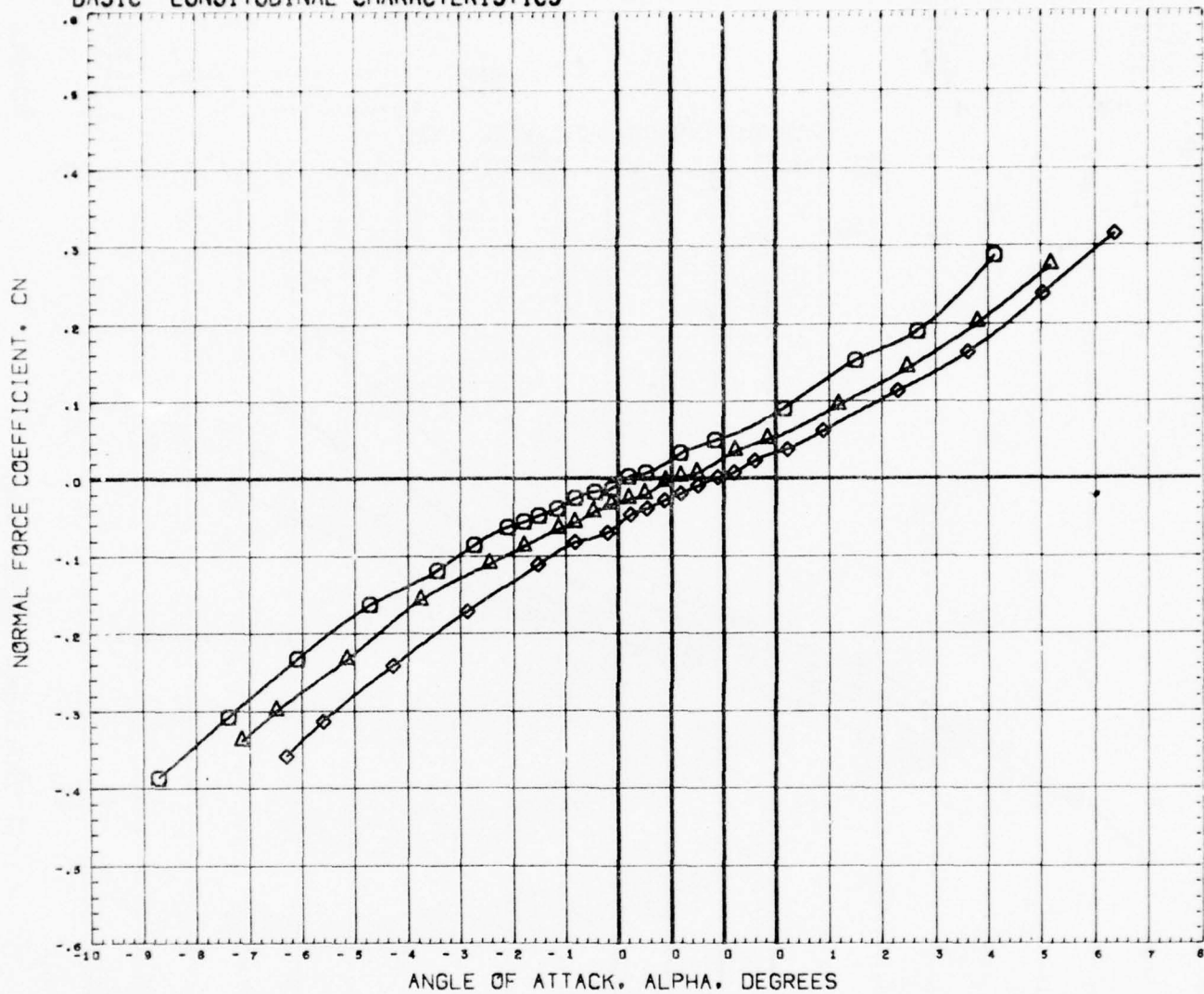

SYMBOL	MACH	PARAMETRIC VALUES				REFERENCE INFORMATION		
○	1.104	PHI	0.000	M-LGTH	1.500	SREF	7.0686	SQ. IN.
△	1.199	C-LGTH	5.000	C-DIA	0.500	LREF	3.0000	INCHES
◇	1.299					BREF	3.0000	INCHES
						YMRP	0.0000	INCHES
						ZMRP	0.0000	INCHES
						SCALE	0.0000	NONE

REFERENCE FILE

AEDC TEST PWT-4T201 CONE-CYLINDER, N1M2C2

(RTAM10) 10 MAR 72

PAGE 34

BASIC LONGITUDINAL CHARACTERISTICS

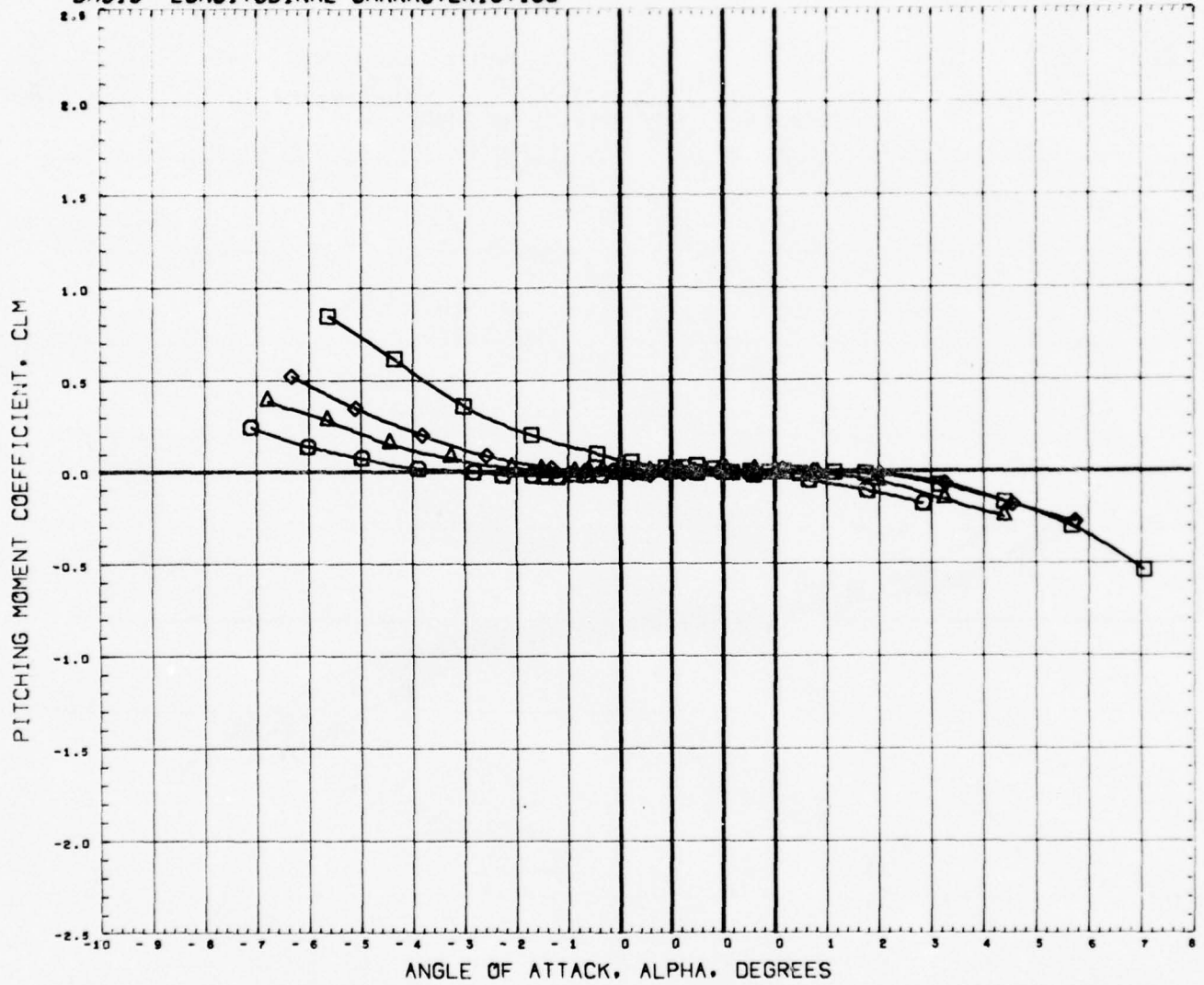

SYMBOL	MACH	PARAMETRIC VALUES				REFERENCE INFORMATION		
○	0.500	PHI	0.000	M-LGTH	1.500	SREF	7.0686	50. IN.
△	0.801	C-LGTH	5.000	C-DIA	0.500	LREF	3.0000	INCHES
◇	0.948					BREF	3.0000	INCHES
□	0.999					XMRP	0.0000	INCHES
						YMRP	0.0000	INCHES
						ZMRP	0.0000	INCHES
						SCALE	0.0000	NONE

REFERENCE FILE
AEDC TEST PWT-4T201 CONE-CYLINDER, N1M2C2

(RTAM10) 10 MAR 72 PAGE 35

BASIC LONGITUDINAL CHARACTERISTICS

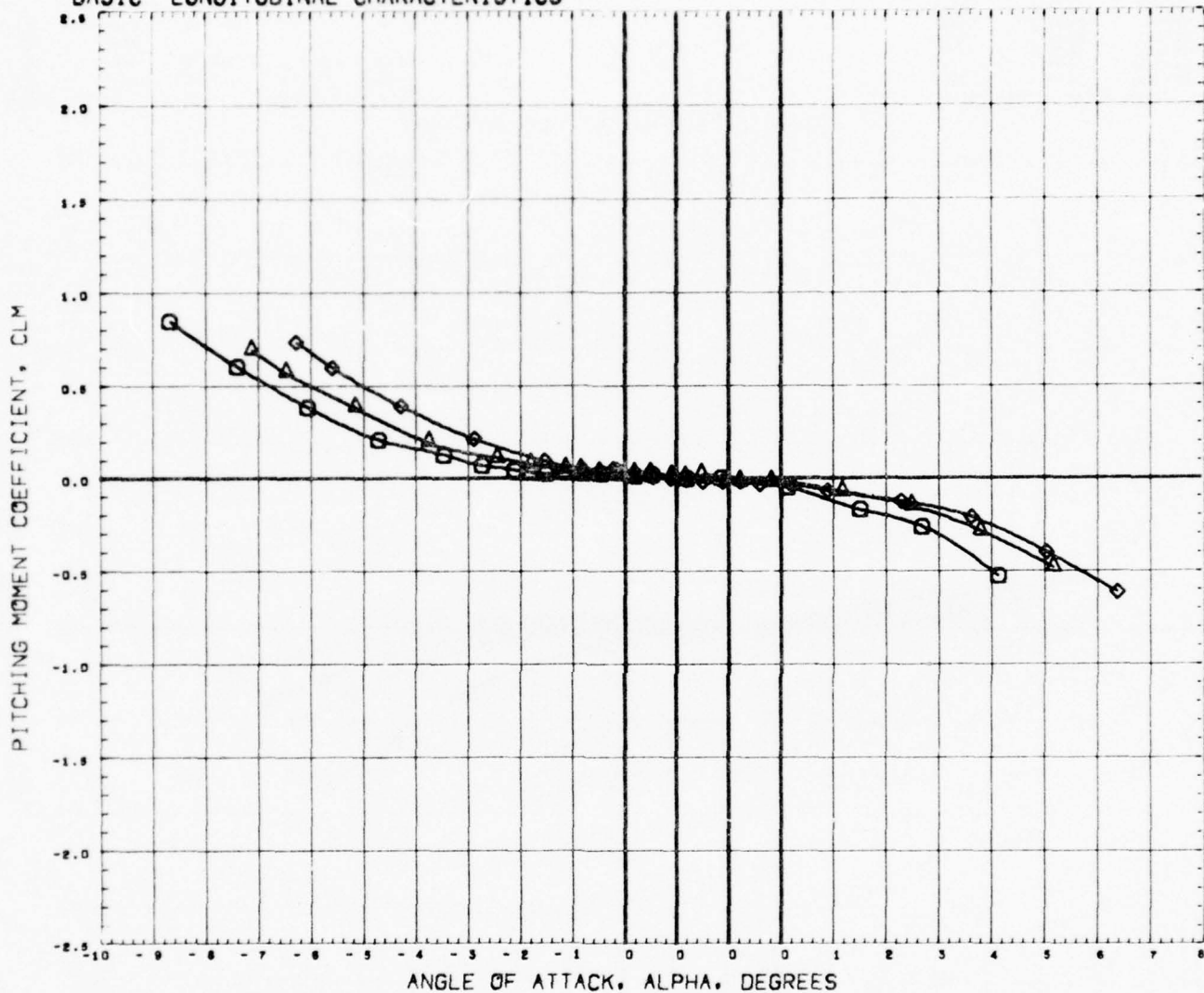

SYMBOL		MACH	PARAMETRIC VALUES				REFERENCE INFORMATION		
○		1.104	PHI	0.000	M-LGTH	1.500	SREF	7.0686	50. IN.
△		1.199	C-LGTH	5.000	C-DIA	0.500	LREF	3.0000	INCHES
◇		1.299					BREF	3.0000	INCHES
							XMRP	0.0000	INCHES
							YMRP	0.0000	INCHES
							ZMRP	0.0000	INCHES
							SCALE	0.0000	NONE

REFERENCE FILE

AEDC TEST PWT-4T201 CONE-CYLINDER. N1M2C2

(RTAM10) 10 MAR 72

PAGE 36

BASIC LONGITUDINAL CHARACTERISTICS

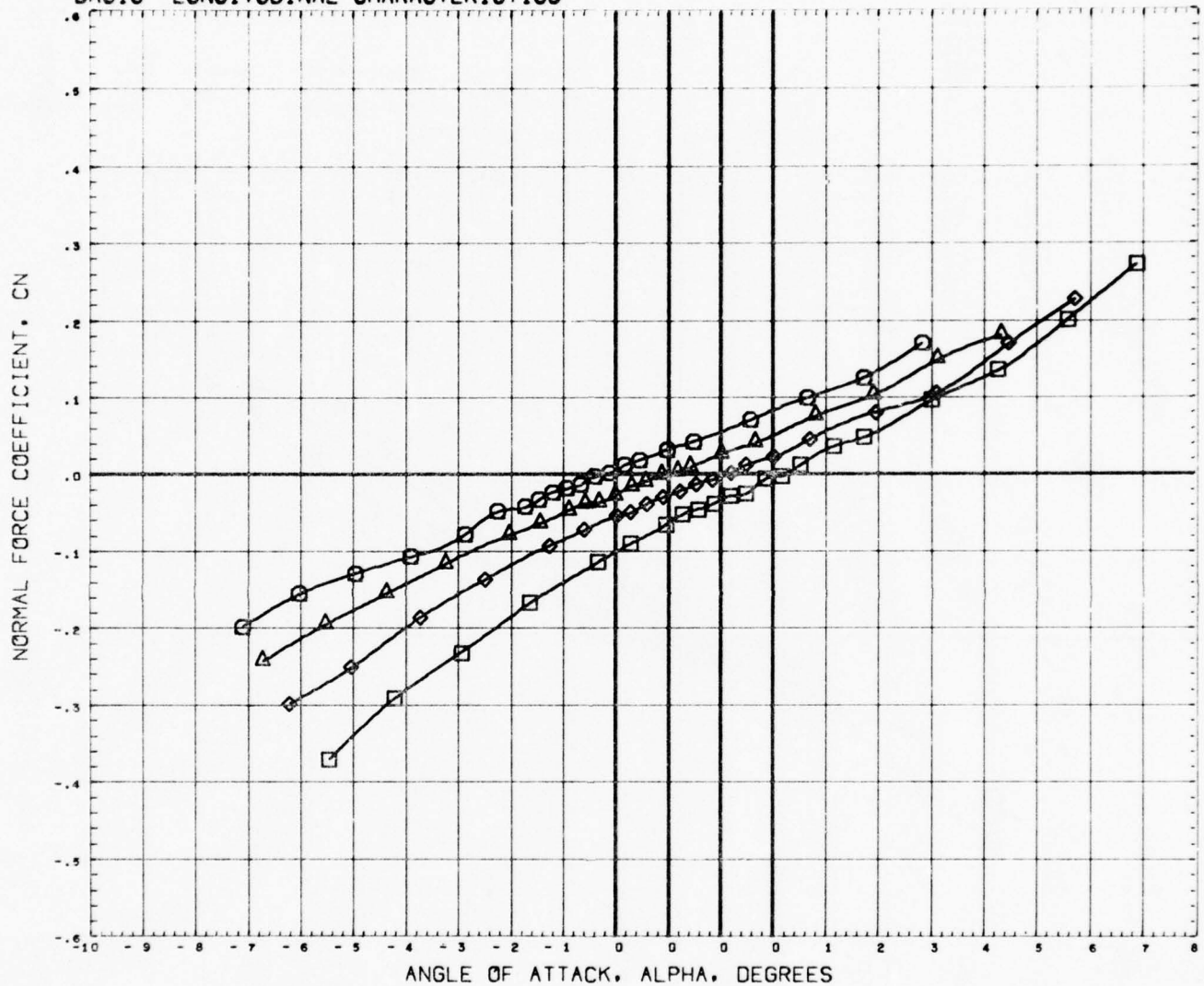

SYMBOL	MACH	PARAMETRIC VALUES			
○	0.500	PHI	0.000	M-LGTH	1.500
△	0.801	C-LGTH	5.000	C-DIA	0.670
◇	0.953				
□	0.999				

REFERENCE INFORMATION		
SREF	7.0686	SQ. IN.
LREF	3.0000	INCHES
BREF	3.0000	INCHES
XMRP	0.0000	INCHES
YMRP	0.0000	INCHES
ZMRP	0.0000	INCHES
SCALE	0.0000	NONE

REFERENCE FILE

AEDC TEST PWT-4T201 CONE-CYLINDER, N1M2C3

(RTAM11) 10 MAR 72

PAGE 37

BASIC LONGITUDINAL CHARACTERISTICS

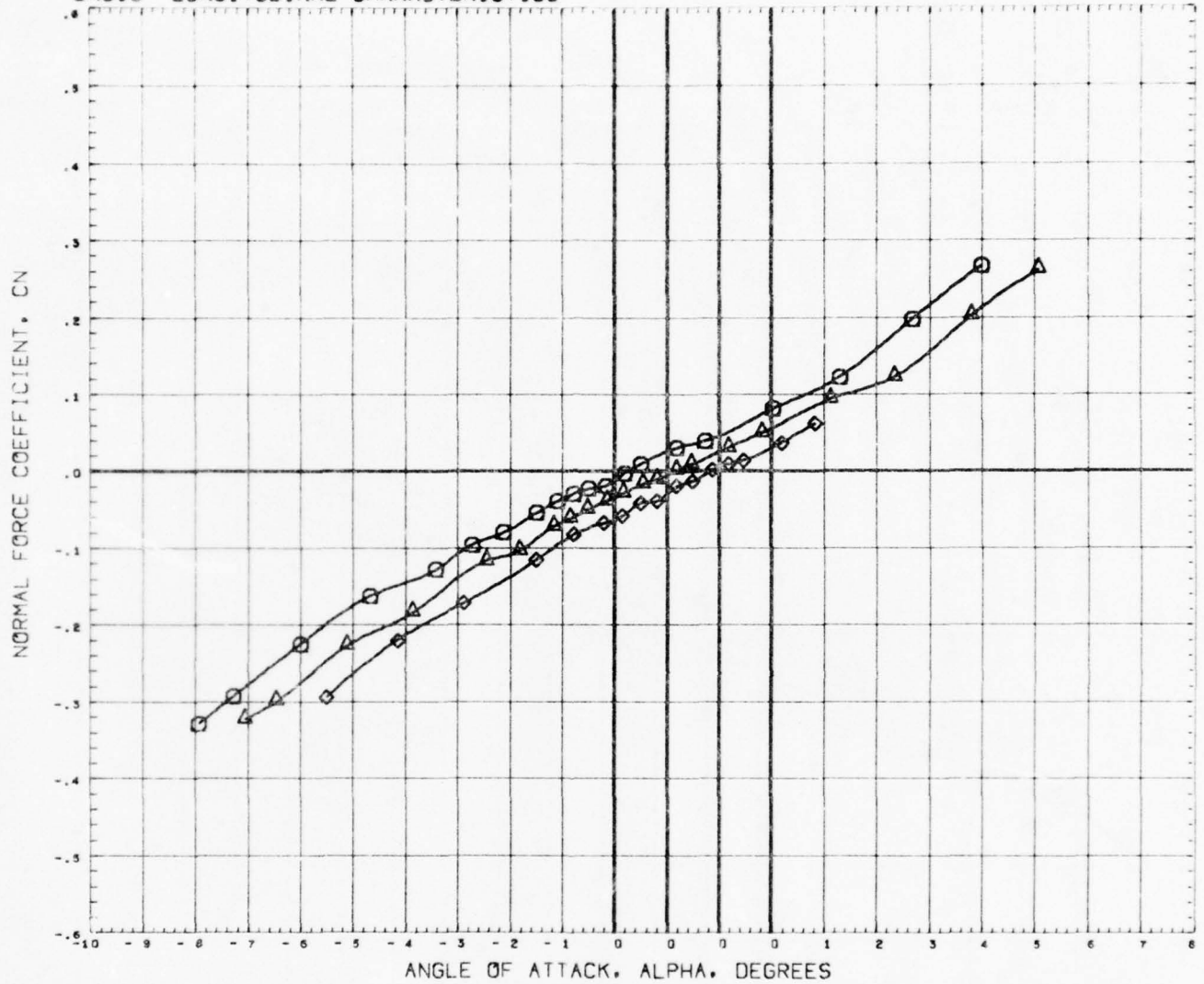

SYMBOL	MACH	PHI	PARAMETRIC VALUES		
○	1.099	0.000	M-LGTH	1.500	
△	1.197	C-LGTH	5.000	C-DIA	0.670
◇	1.295				

REFERENCE INFORMATION		
SREF	7.0686	SQ. IN.
LREF	3.0000	INCHES
BREF	3.0000	INCHES
XWRP	0.0000	INCHES
YWRP	0.0000	INCHES
ZWRP	0.0000	INCHES
SCALE	0.0000	NONE

REFERENCE FILE

AEDC TEST PWT-4T201 CONE-CYLINDER, N1M2C3

(RTAM11) 10 MAR 72 PAGE 38

BASIC LONGITUDINAL CHARACTERISTICS

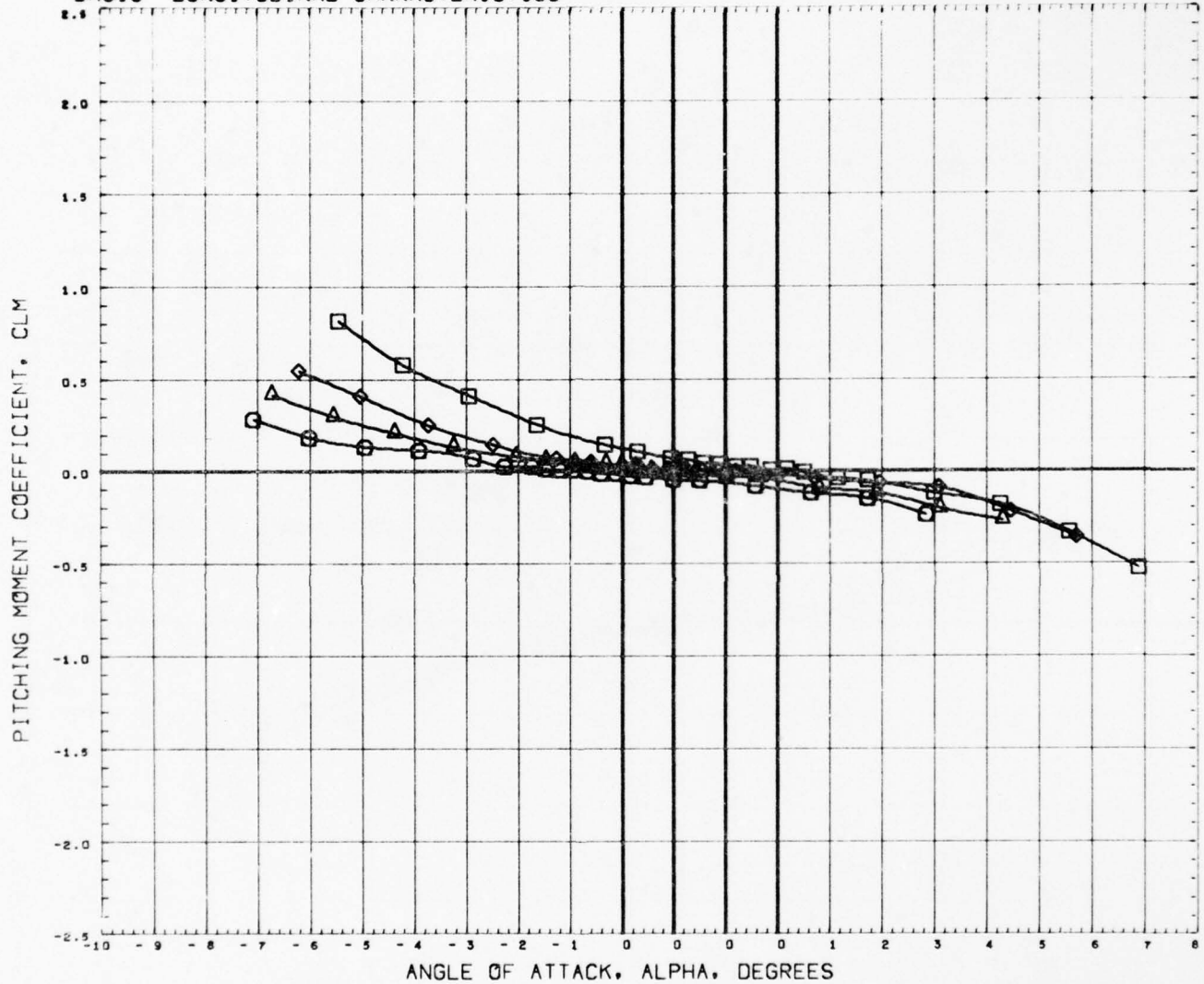

SYMBOL	MACH	PARAMETRIC VALUES				REFERENCE INFORMATION		
○	0.500	PHI	0.000	M-LGTH	1.500	SREF	7.0686	SQ. IN.
△	0.801	C-LGTH	5.000	C-DIA	0.670	LREF	3.0000	INCHES
◇	0.953					BREF	3.0000	INCHES
□	0.999					XMRP	0.0000	INCHES
						YMRP	0.0000	INCHES
						ZMRP	0.0000	INCHES
						SCALE	0.0000	NONE

REFERENCE FILE

AEDC TEST PWT-4T201 CONE-CYLINDER, N1M2C3

(RTAM11) 10 MAR 72

PAGE 39

BASIC LONGITUDINAL CHARACTERISTICS

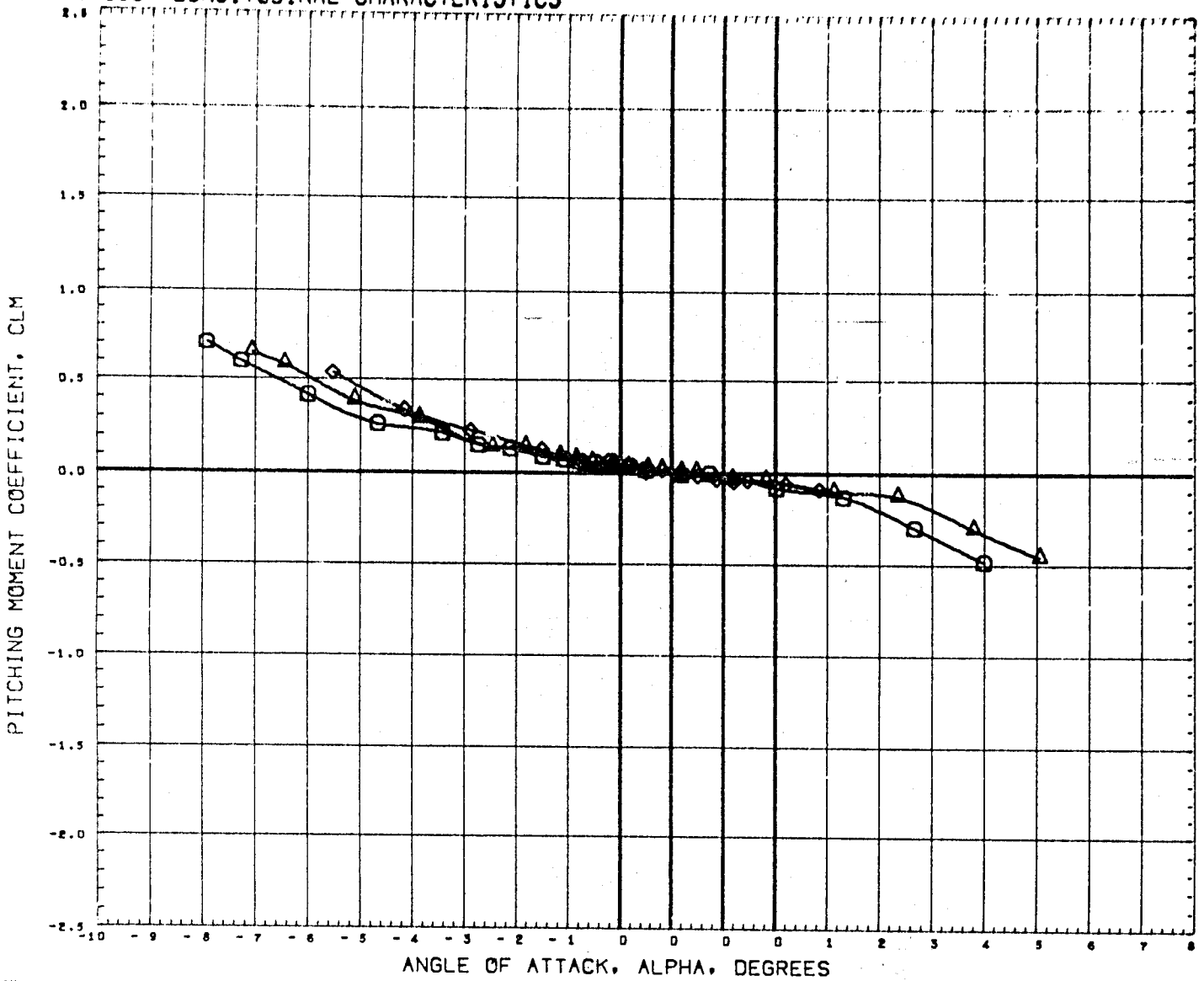

SYMBOL	MACH	PARAMETRIC VALUES				REFERENCE INFORMATION		
○	1.099	PHI	0.000	M-LGTH	1.500	SREF	7.0686	50. IN.
△	1.197	C-LGTH	5.000	C-DIA	0.670	LREF	3.0000	INCHES
◇	1.295					BREF	3.0000	INCHES
						XMRP	0.0000	INCHES
						YMRP	0.0000	INCHES
						ZMRP	0.0000	INCHES
						SCALE	0.0000	NONE

REFERENCE FILE

AEOC TEST PWT-4T201 CONE-CYLINDER, N1M2C3

(RTAM11) 10 MAR 72

PAGE 40

BASIC LONGITUDINAL CHARACTERISTICS

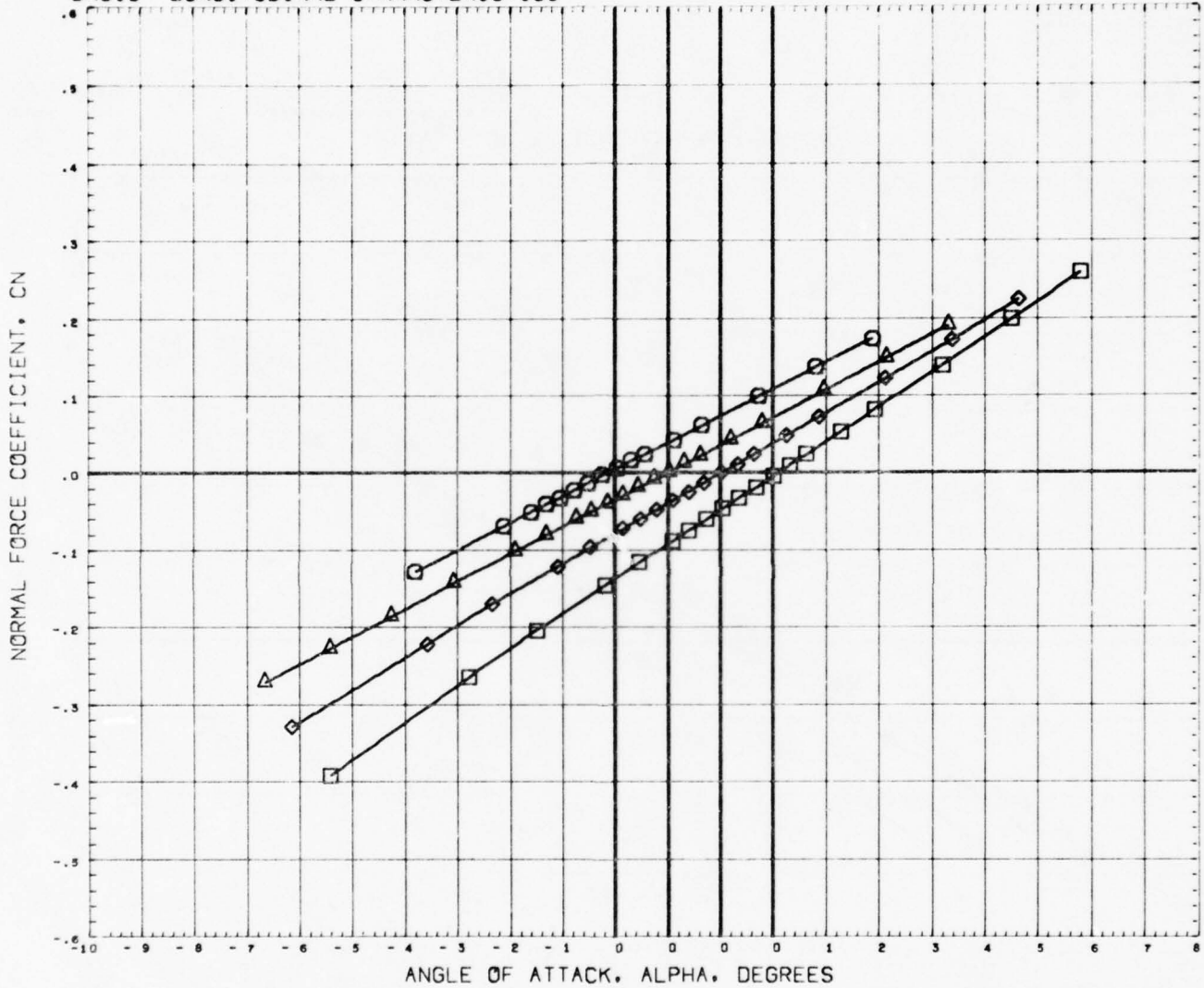

SYMBOL	MACH	PARAMETRIC VALUES			
○	0.500	PHI	0.000	M-LGTH	1.500
△	0.799	C-LGTH	5.000	C-DIA	0.400
◇	0.948				
□	1.000				

REFERENCE INFORMATION		
SREF	7.0686	50. IN.
LREF	3.0000	INCHES
BREF	3.0000	INCHES
XMRP	0.0000	INCHES
YMRP	0.0000	INCHES
ZMRP	0.0000	INCHES
SCALE	0.0000	NONE

REFERENCE FILE

AEDC TEST PWT-4T201 CONE-CYLINDER, N1M2C5

(RTAM12) 10 MAR 72

PAGE 41

BASIC LONGITUDINAL CHARACTERISTICS

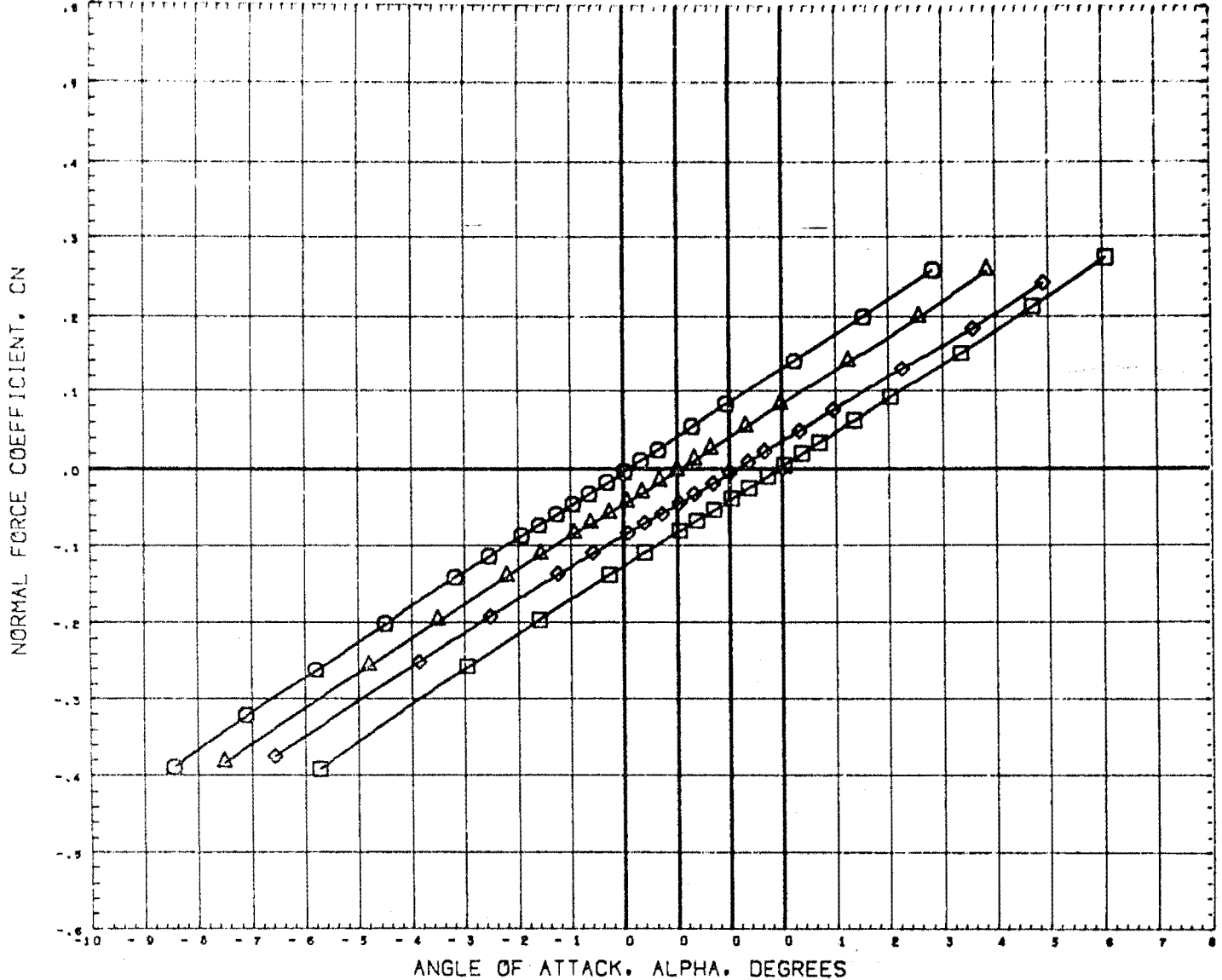

SYMBOL	MACH	PHI	PARAMETRIC VALUES		REFERENCE INFORMATION			
○	1.052	0.000	M-LENGTH	1.500	SREF	7.0666	80. IN.	
△	1.103	C-LENGTH	3.000	C-DIA	0.400	LREF	3.0000	INCHES
◇	1.200				BREF	3.0000	INCHES	
□	1.300				XMRP	0.0000	INCHES	
					YMRP	0.0000	INCHES	
					ZMRP	0.0000	INCHES	
					SCALE	0.0000	NONE	

REFERENCE FILE

AEDC TEST PWT-4T201 CONE-CYLINDER. N1M2C5

(RTAM12) 10 MAR 72

PAGE 42

BASIC LONGITUDINAL CHARACTERISTICS

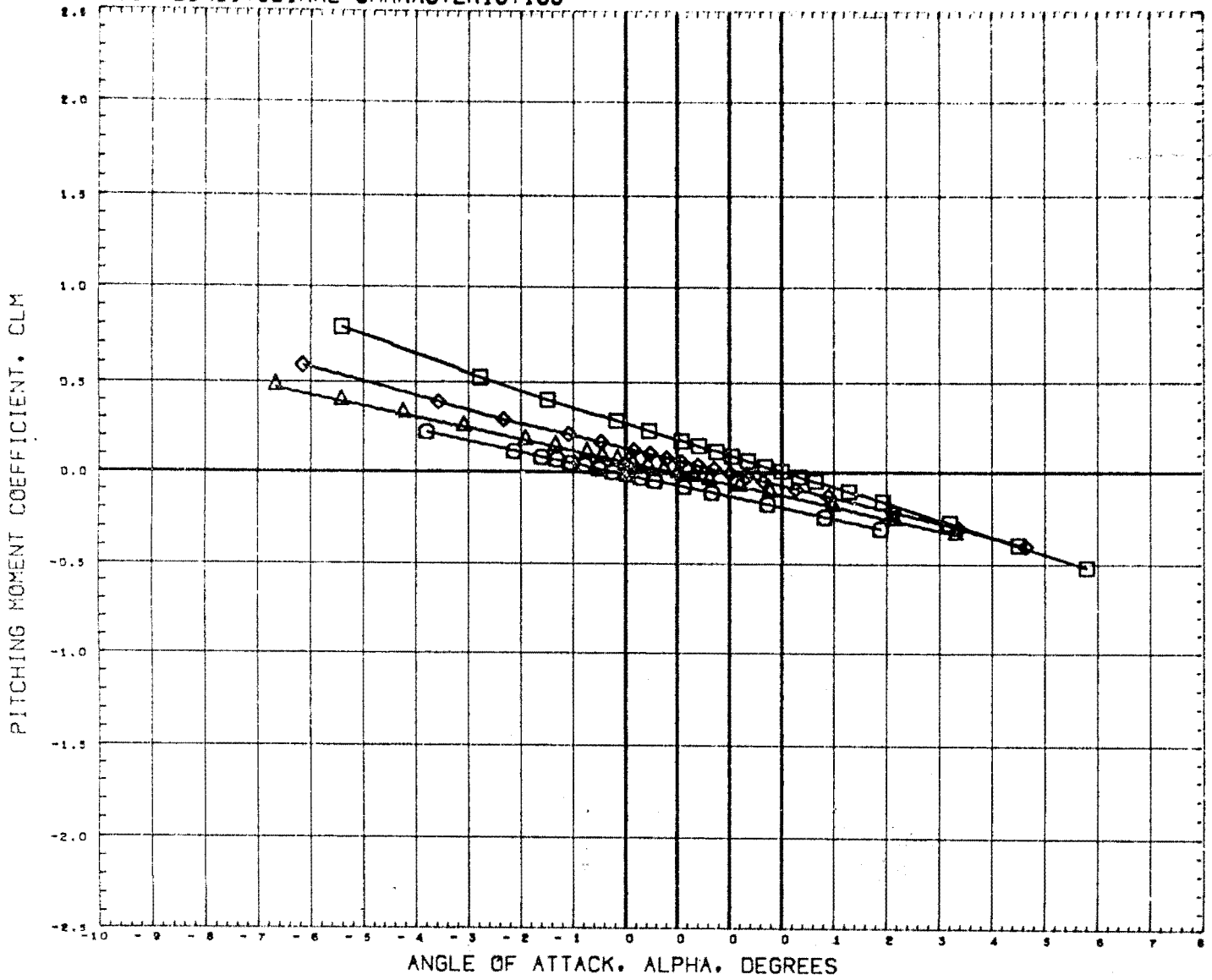

SYMBOL	MACH	PARAMETRIC VALUES				REFERENCE INFORMATION		
		PHI	M-LGTH	C-DIA	SREF	LREF	BREF	
△	0.500	0.000	1.500		7.0686	3.0000	3.0000	
◇	0.799	5.000	0.400		3.0000	3.0000	3.0000	
○	0.948				0.0000	0.0000	0.0000	
□	1.000				0.0000	0.0000	0.0000	

REFERENCE FILE

BASIC LONGITUDINAL CHARACTERISTICS

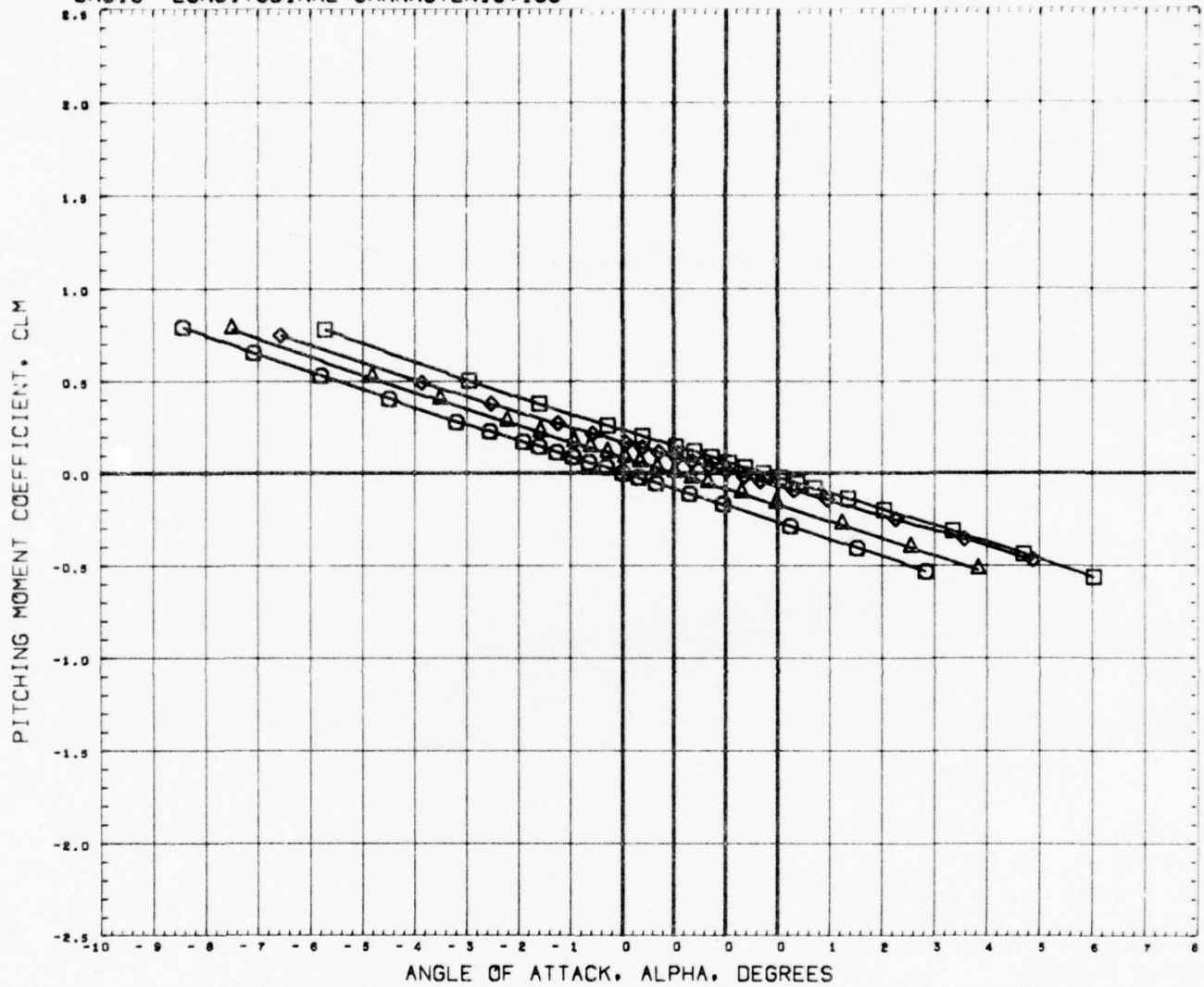

SYMBOL	MACH	PHI	PARAMETRIC VALUES			REFERENCE INFORMATION		
○	1.052	0.000	M-LGTH	1.500	SREF	7.0686	SQ. IN.	
△	1.103	C-LGTH	5.000	C-DIA	0.400	LREF	3.0000	INCHES
◇	1.200					BREF	3.0000	INCHES
□	1.300					XMRP	0.0000	INCHES
						YMRP	0.0000	INCHES
						ZMRP	0.0000	INCHES
						SCALE	0.0000	NONE

REFERENCE FILE

AEDC TEST PWT-4T201 CONE-CYLINDER, N1M2C5

(RTAM12) 10 MAR 72

PAGE 44

BASIC LONGITUDINAL CHARACTERISTICS

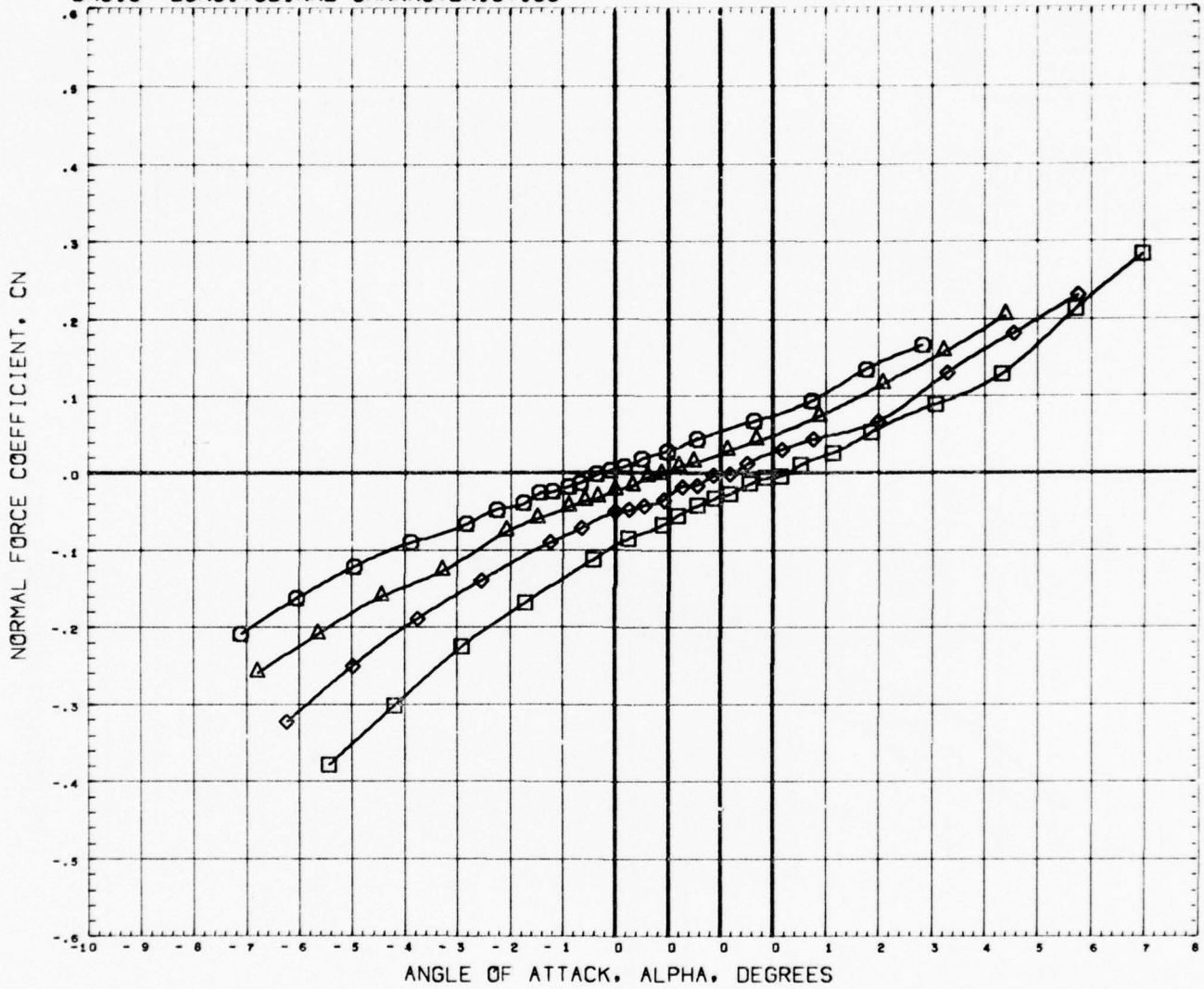

SYMBOL	MACH	PARAMETRIC VALUES			
○	0.500	PHI	0.000	H-LGTH	2.250
△	0.801	C-LGTH	6.500	C-DIA	0.500
◇	0.949				
□	1.001				

REFERENCE INFORMATION		
SREF	7.0686	50. IN.
LREF	3.0000	INCHES
BREF	3.0000	INCHES
YMRP	0.0000	INCHES
ZMRP	0.0000	INCHES
SCALE	0.0000	NONE

REFERENCE FILE

AEDC TEST PWT-4T201 CONE-CYLINDER, N1M1C4

(RTAM13) 10 MAR 72 PAGE 45

BASIC LONGITUDINAL CHARACTERISTICS

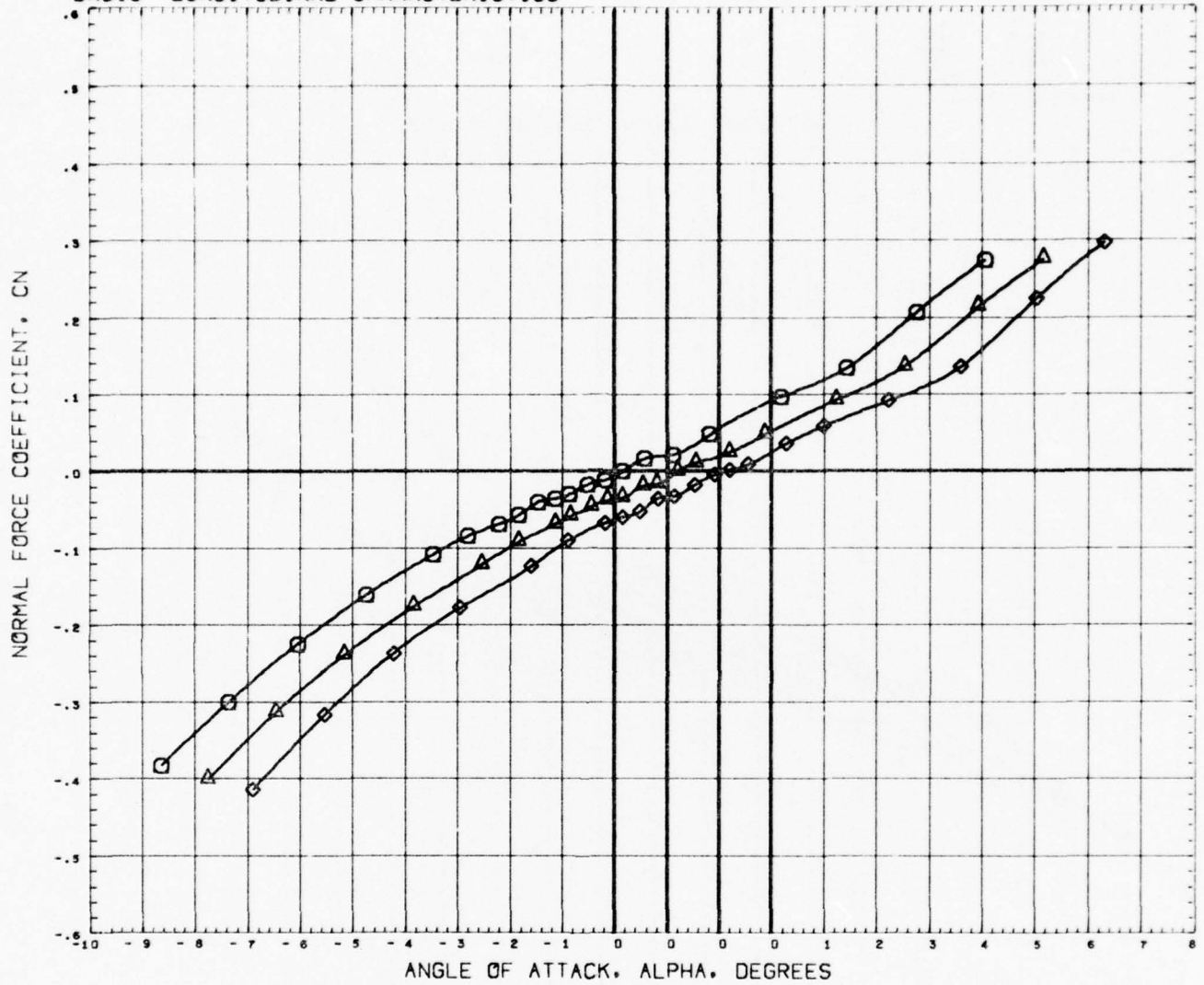

SYMBOL	MACH	PARAMETRIC VALUES	REFERENCE INFORMATION
○	1.099	PHI 0.000 M-LGTH 2.250	SREF 7.0686 SQ. IN.
△	1.198	C-LGTH 6.500 C-DIA 0.500	LREF 3.0000 INCHES
◇	1.297		BREF 3.0000 INCHES
			XWRP 0.0000 INCHES
			YWRP 0.0000 INCHES
			ZWRP 0.0000 INCHES
			SCALE 0.0000 NONE

REFERENCE FILE

BASIC LONGITUDINAL CHARACTERISTICS

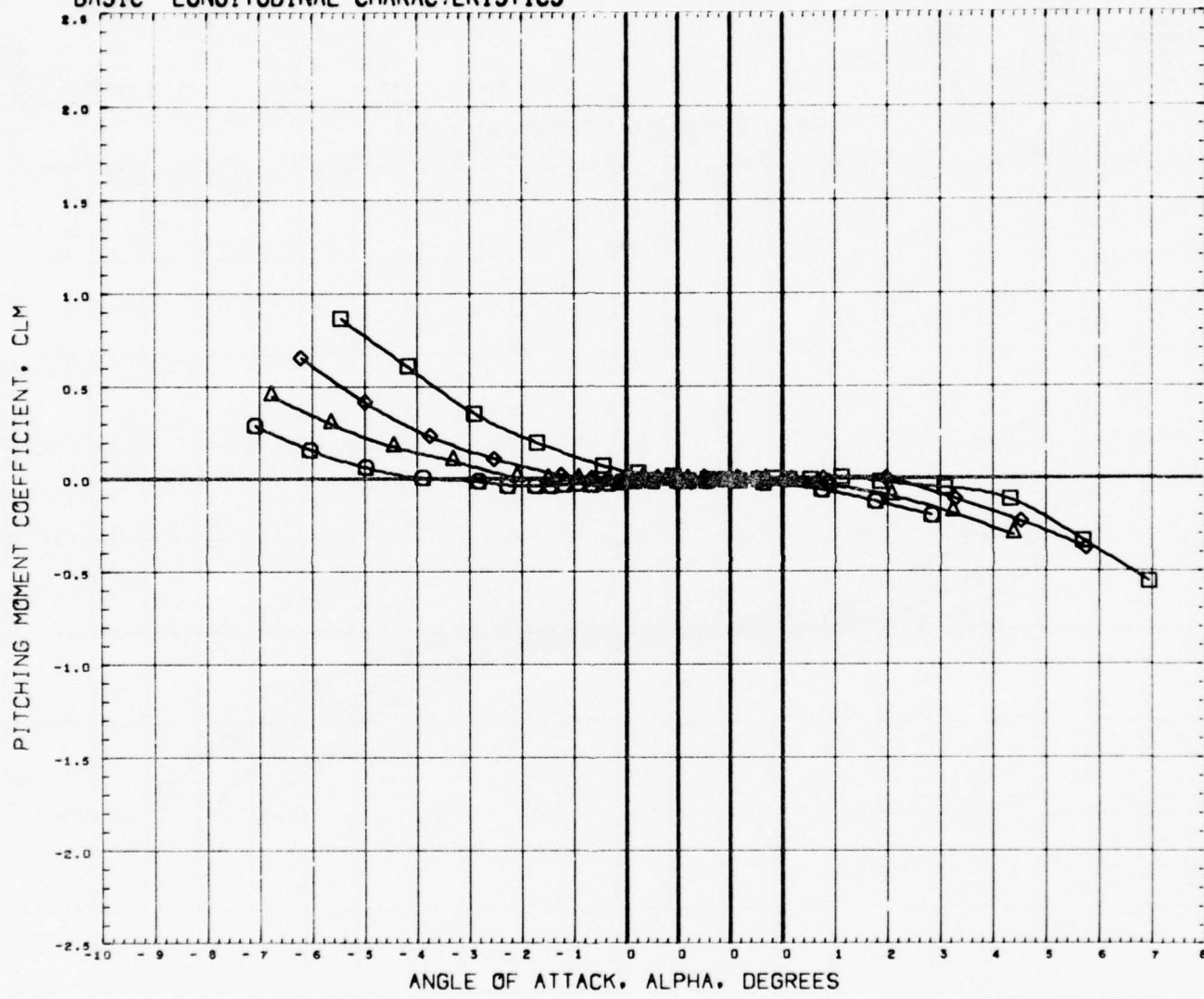

SYMBOL	MACH	PARAMETRIC VALUES				REFERENCE INFORMATION		
○	0.500	PHT	0.000	M-LGTH	2.250	SREF	7.0686	50. IN.
△	0.801	C-LGTH	6.500	C-DIA	0.500	LREF	3.0000	INCHES
◇	0.949					BREF	3.0000	INCHES
□	1.001					XMRP	0.0000	INCHES
						YMRP	0.0000	INCHES
						ZMRP	0.0000	INCHES
						SCALE	0.0000	NONE

REFERENCE FILE

BASIC LONGITUDINAL CHARACTERISTICS

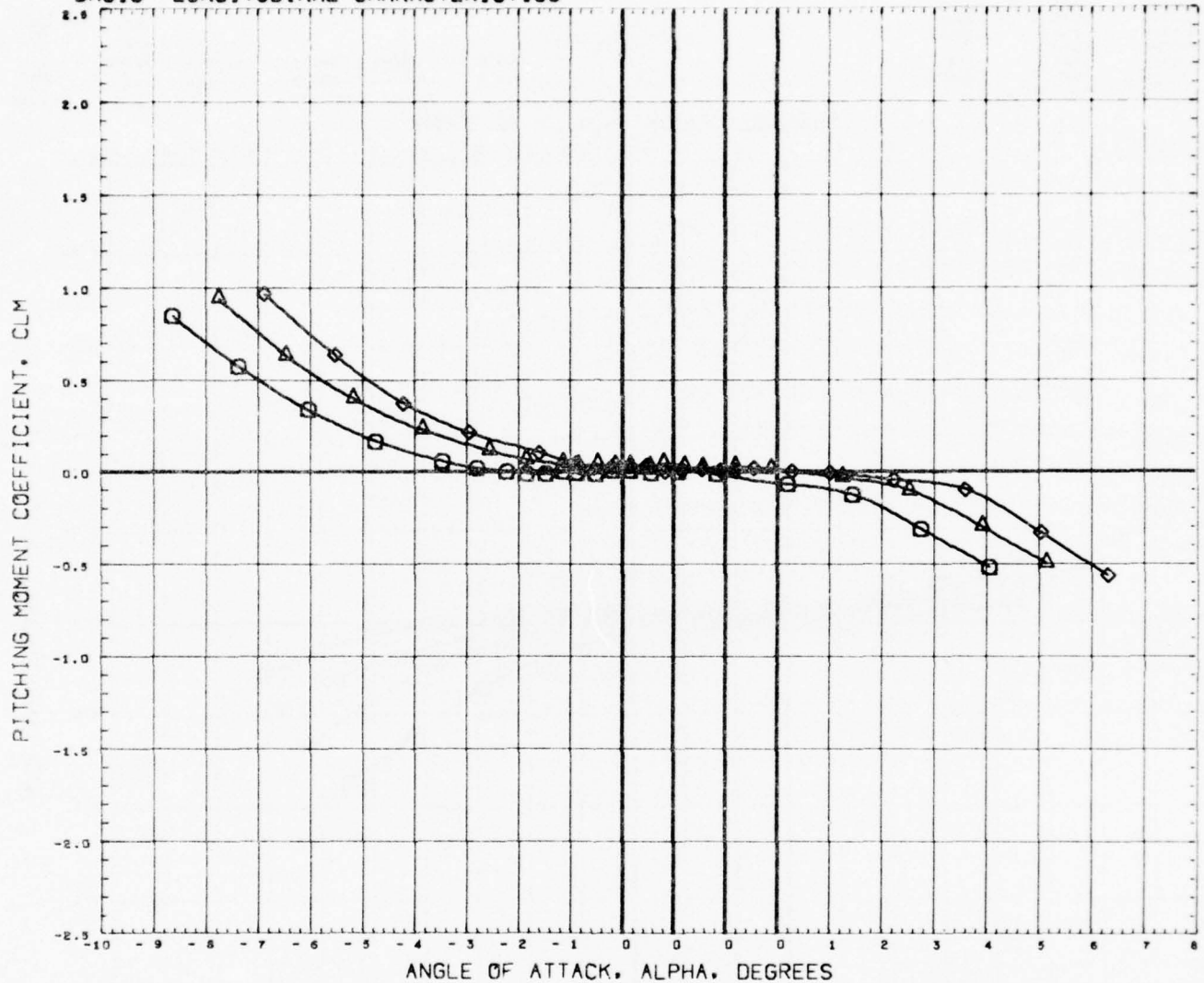

SYMBOL	MACH	PARAMETRIC VALUES				REFERENCE INFORMATION		
○	1.099	PHI	0.000	M-LGTH	2.250	SREF	7.0686	SQ. IN.
△	1.198	C-LGTH	6.500	C-DIA	0.500	LREF	3.0000	INCHES
◇	1.297					BREF	3.0000	INCHES
						XMRP	0.0000	INCHES
						YMRP	0.0000	INCHES
						ZMRP	0.0000	INCHES
						SCALE	0.0000	NONE

REFERENCE FILE

AEDC TEST PWT-4T201 CONE-CYLINDER, N1M1C4

(RTAM13) 10 MAR 72

PAGE 48

BASIC LONGITUDINAL CHARACTERISTICS

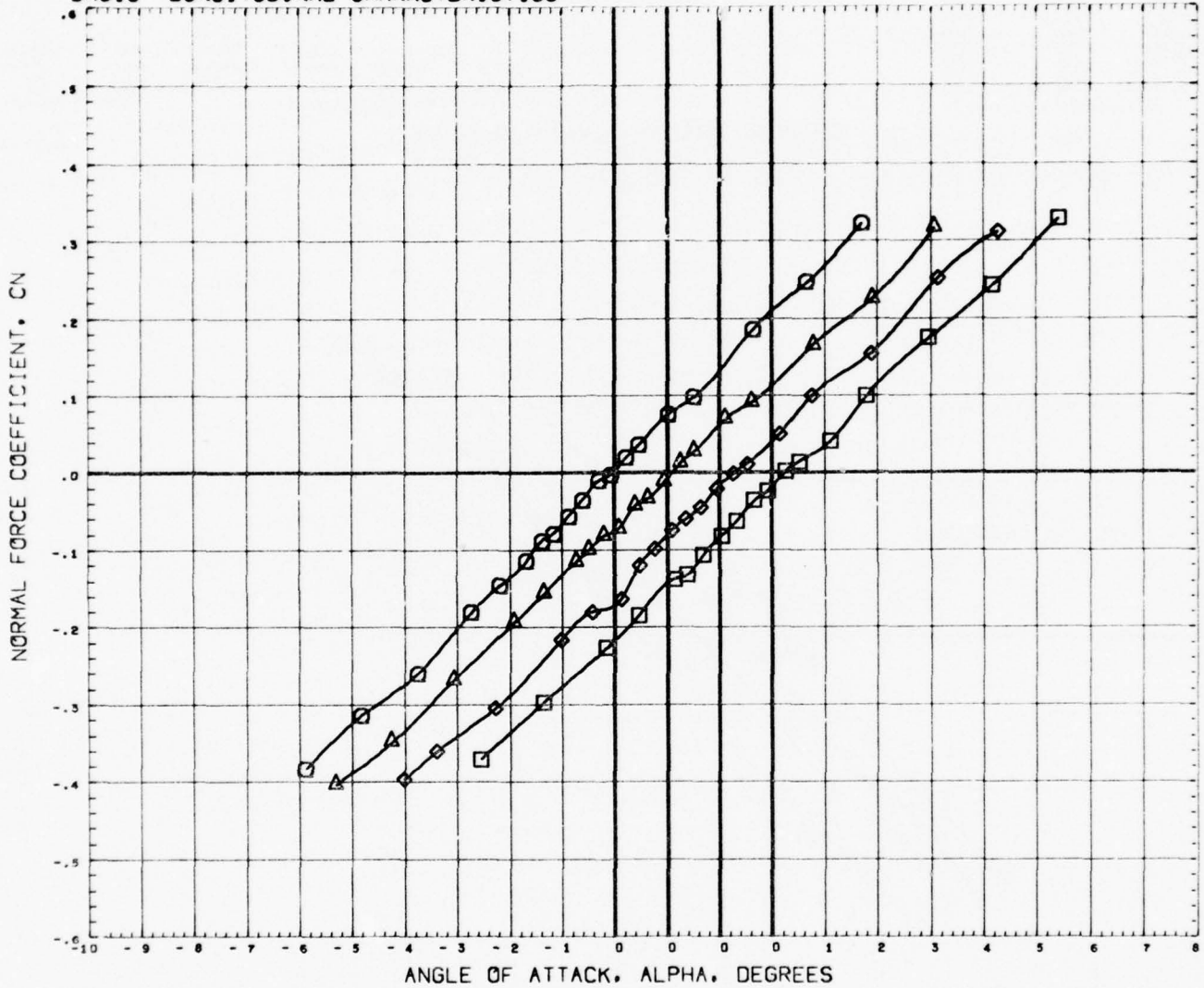

SYMBOL	MACH	PARAMETRIC VALUES				REFERENCE INFORMATION		
○	0.500	PHI	0.000	M-LGTH	2.250	SREF	7.0686	SQ. IN.
△	0.798	LS-LGH	2.500	S-WDTH	0.200	LREF	3.0000	INCHES
◇	0.950	R-WDTH	1.000			BREF	3.0000	INCHES
□	1.001					XMRP	0.0000	INCHES
						YMRP	0.0000	INCHES
						ZMRP	0.0000	INCHES
						SCALE	0.0000	NONE

REFERENCE FILE

BASIC LONGITUDINAL CHARACTERISTICS

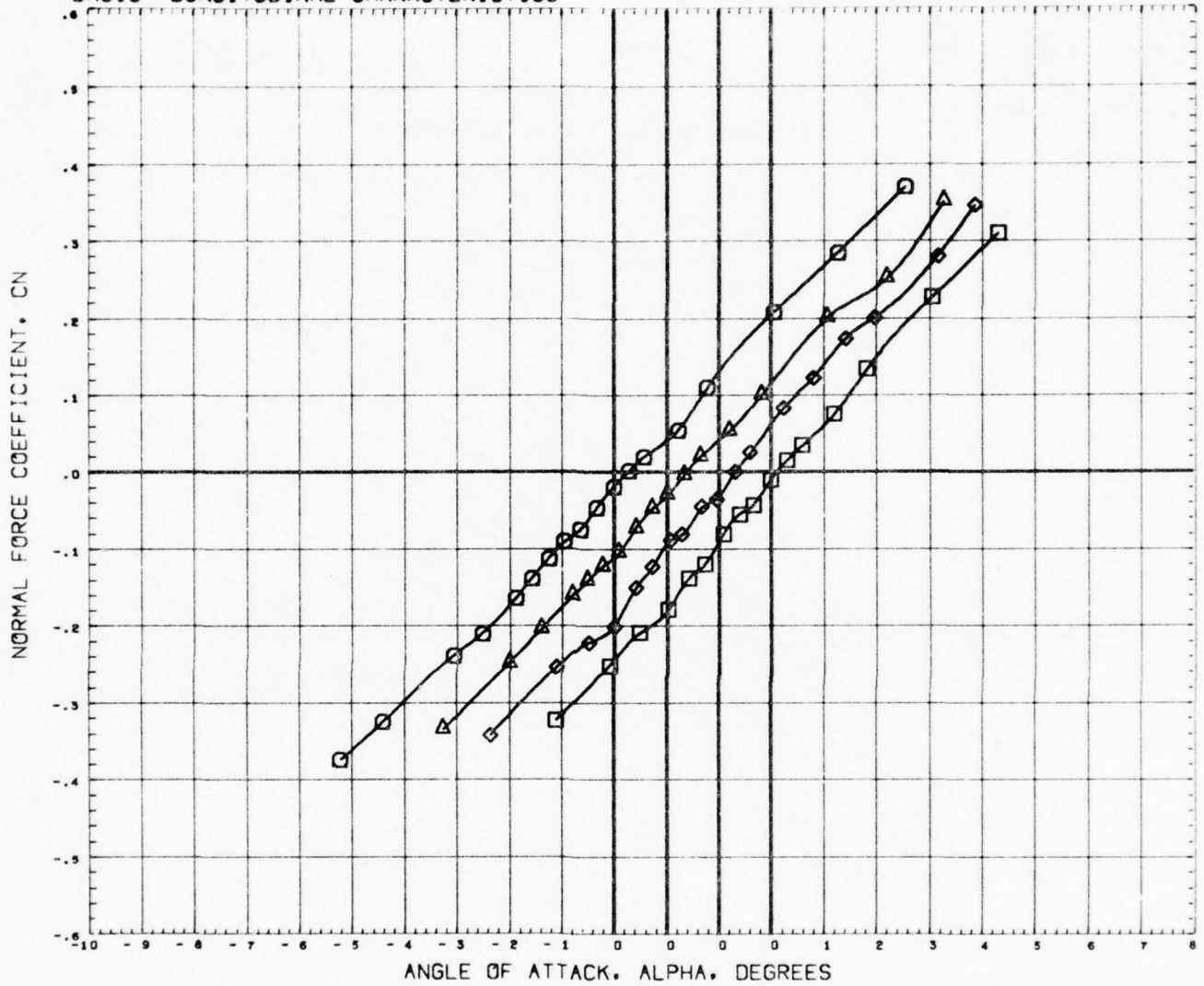

SYMBOL	MACH	PARAMETRIC VALUES			
○	1.045	PHI	0.000	M-LGTH	2.250
△	1.098	LS-LGH	2.500	S-WDTH	0.200
◇	1.197	R-WDTH	1.000		
□	1.296				

REFERENCE INFORMATION		
SREF	7.0686	SQ. IN.
LREF	3.0000	INCHES
BREF	3.0000	INCHES
XMRP	0.0000	INCHES
YMRP	0.0000	INCHES
ZMRP	0.0000	INCHES
SCALE	0.0000	NONE

REFERENCE FILE

BASIC LONGITUDINAL CHARACTERISTICS

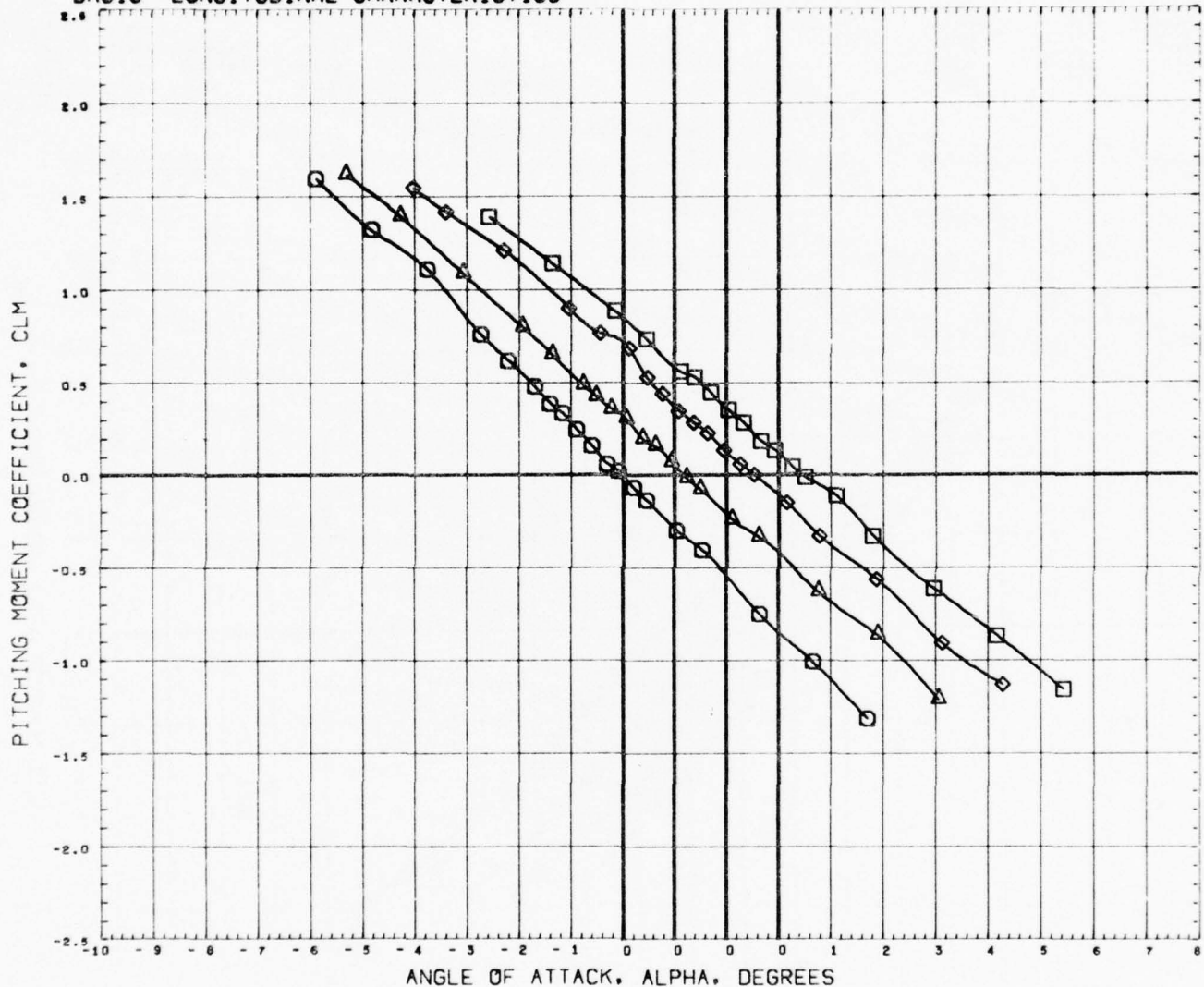

SYMBOL	MACH	PARAMETRIC VALUES				REFERENCE INFORMATION		
○	0.500	PHI	0.000	M-LGTH	2.250	SREF	7.0686	SQ. IN.
△	0.798	LS-LGH	2.500	S-WDTH	0.200	LREF	3.0000	INCHES
◇	0.950	R-WDTH	1.000			BREF	3.0000	INCHES
□	1.001					XMRP	0.0000	INCHES
						YMRP	0.0000	INCHES
						ZMRP	0.0000	INCHES
						SCALE	0.0000	NONE

REFERENCE FILE

BASIC LONGITUDINAL CHARACTERISTICS

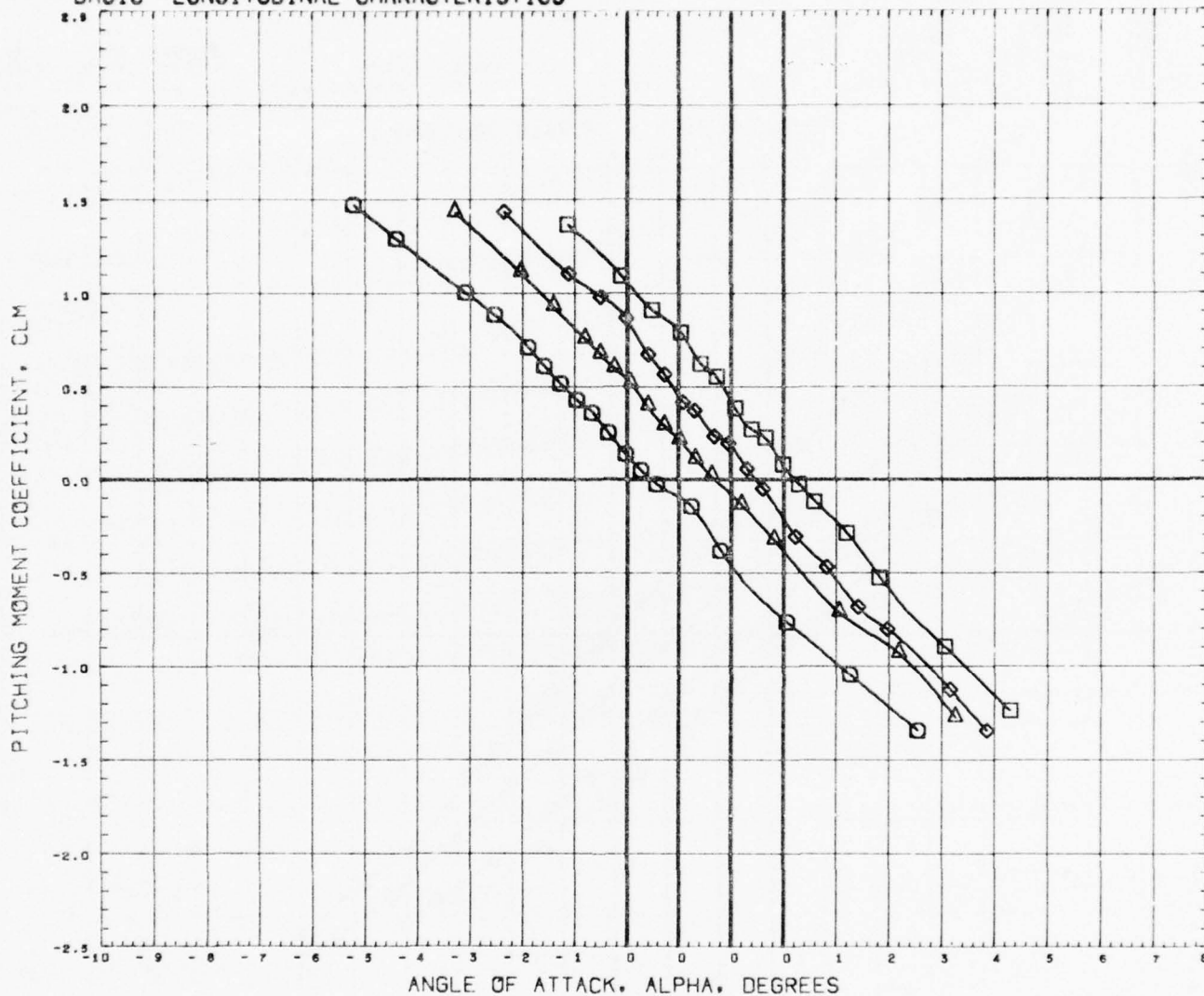

SYMBOL	MACH	PARAMETRIC VALUES				REFERENCE INFORMATION		
○	1.045	PHI	0.000	H-LGTH	2.250	SREF	7.0686	SQ. IN.
△	1.098	LS-LGH	2.500	S-WDTH	0.200	LREF	3.0000	INCHES
◇	1.197	R-WDTH	1.000			BREF	3.0000	INCHES
□	1.296					XMRP	0.0000	INCHES
						YMRP	0.0000	INCHES
						ZMRP	0.0000	INCHES
						SCALE	0.0000	NONE

REFERENCE FILE

BASIC LONGITUDINAL CHARACTERISTICS

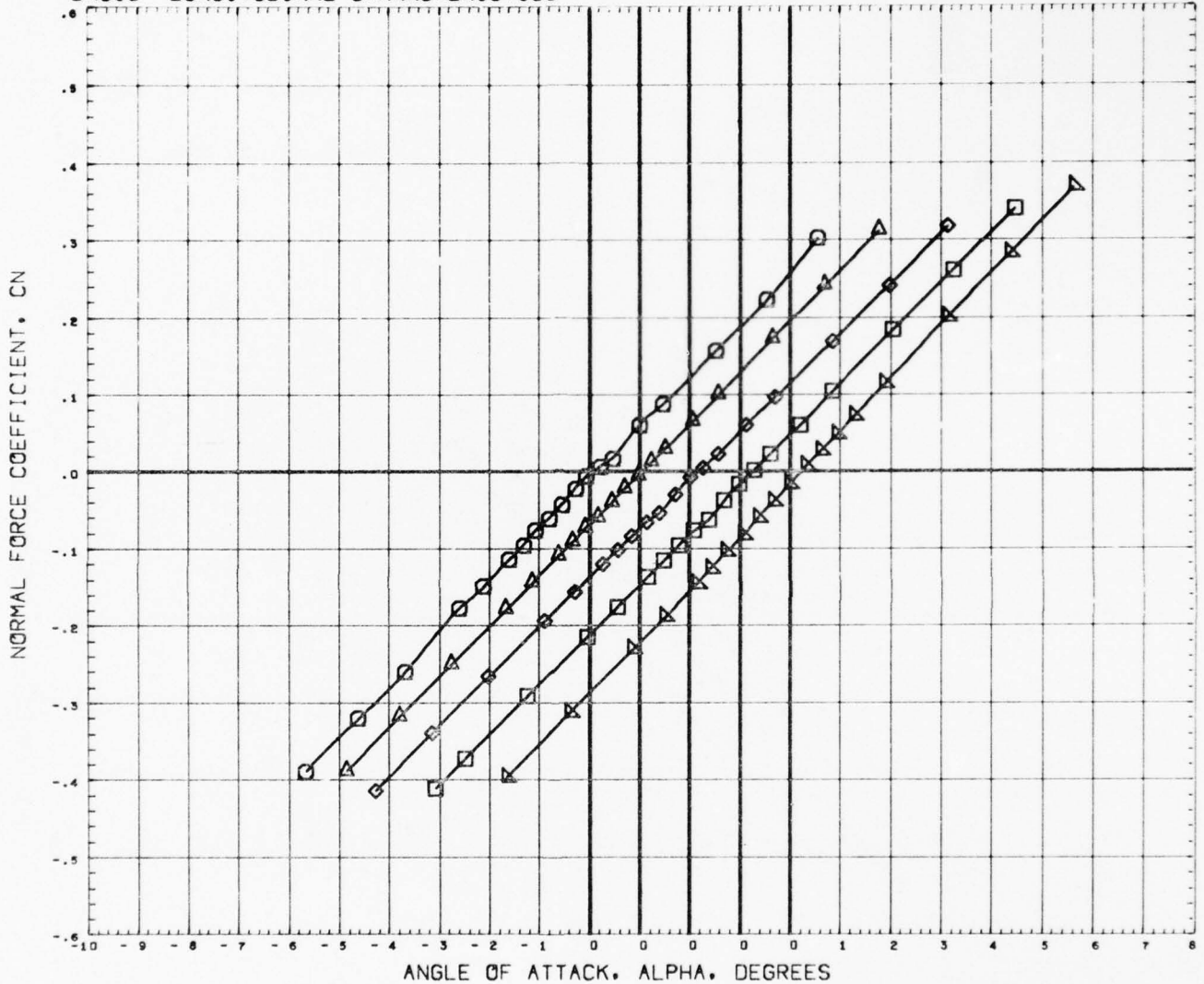

SYMBOL	MACH	PARAMETRIC VALUES				REFERENCE INFORMATION		
○	0.299	PHI	0.000	M-LGTH	1.500	SREF	7.0686	SQ. IN.
◇	0.500	LS-LGH	3.250	S-WDTH	0.200	LREF	3.0000	INCHES
△	0.801	R-WDTH	1.000			BREF	3.0000	INCHES
□	0.949					YMRP	0.0000	INCHES
◇	1.002					ZMRP	0.0000	INCHES
						SCALE	0.0000	NONE

DATA HIST. CODE *6

BASIC LONGITUDINAL CHARACTERISTICS

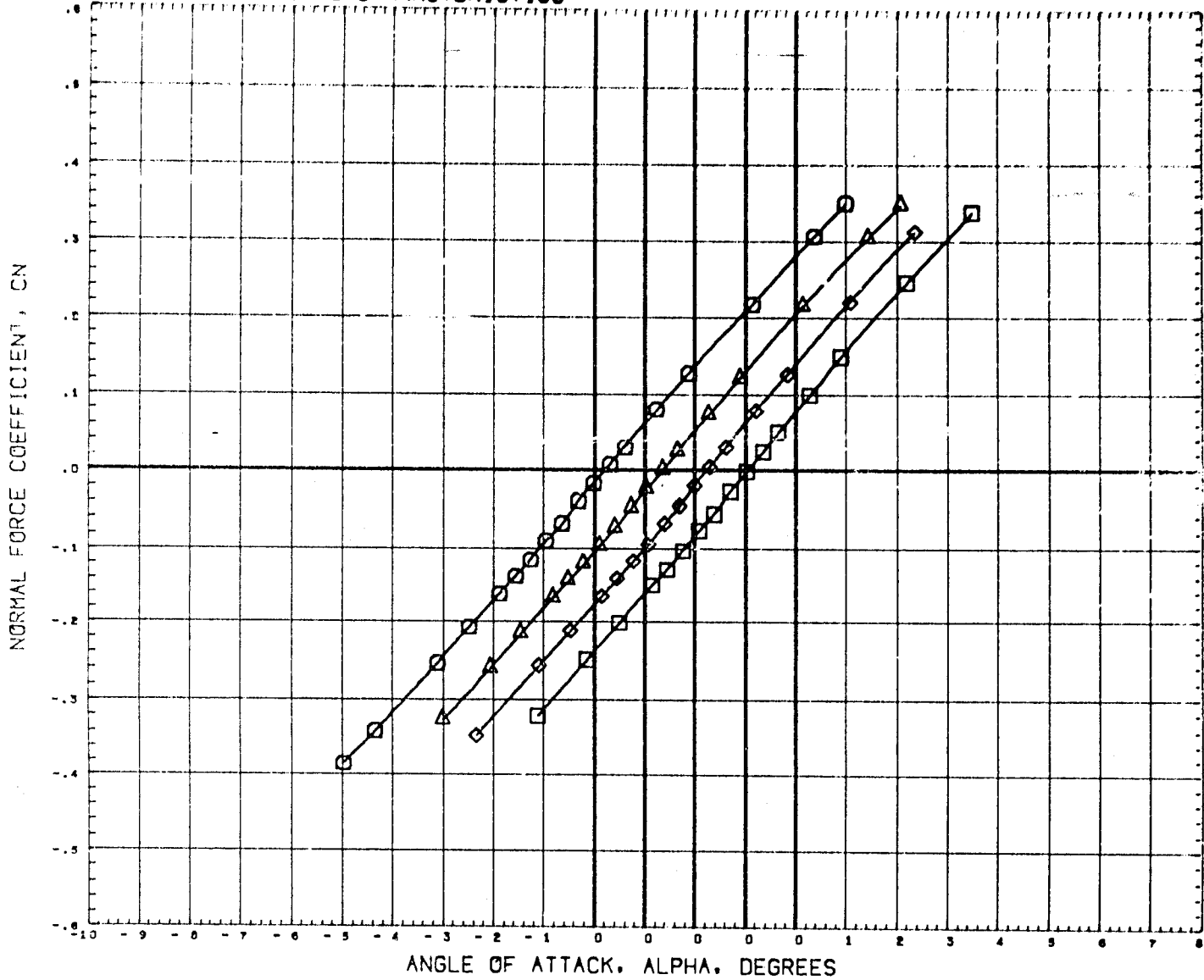

SYMBOL	MACH	PARAMETRIC VALUES			
○	1.052	PHI	0.000	M-LGTH	1.500
△	1.098	LS-LGH	3.250	S-WDTH	0.200
◇	1.199	R-WDTH	-1.000		
□	1.300				

REFERENCE INFORMATION		
SREF	7.0686	50. IN.
LREF	3.0000	INCHES
BREF	3.0000	INCHES
XMRP	0.0000	INCHES
YMRP	0.0000	INCHES
ZMRP	0.0000	INCHES
SCALE	0.0000	NONE

DATA HIST. CODE #6

BASIC LONGITUDINAL CHARACTERISTICS

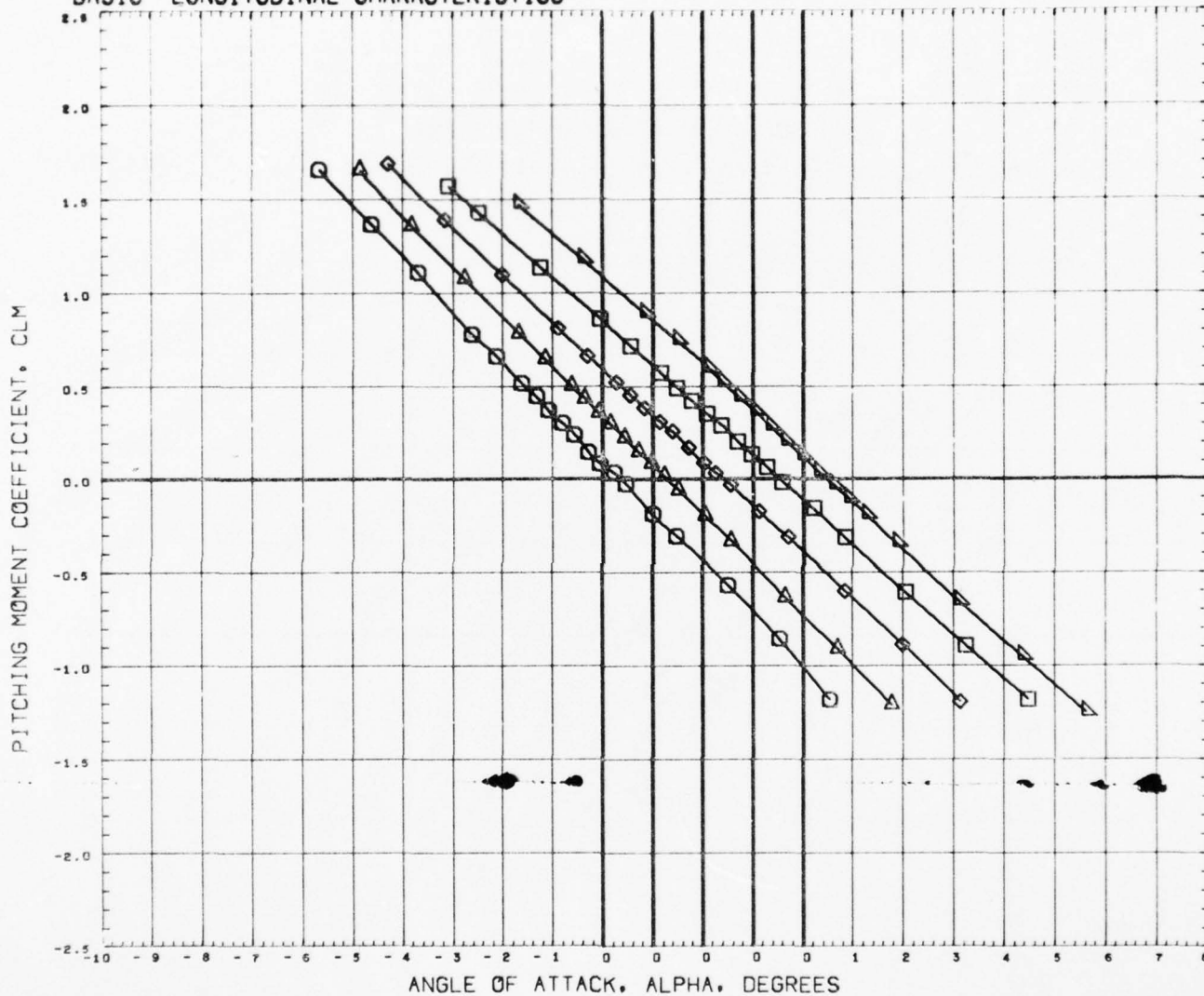

SYMBOL	MACH	PARAMETRIC VALUES				REFERENCE INFORMATION		
○	0.299	PHI	0.000	M-LGTH	1.500	SREF	7.0686	50. IN.
◇	0.500	LS-LGH	3.250	S-WDTH	0.200	LREF	3.0000	INCHES
△	0.801	R-WDTH	1.000			BREF	3.0000	INCHES
□	0.949					XWRF	0.0000	INCHES
◇	1.002					YWRF	0.0000	INCHES
						ZWRF	0.0000	INCHES
						SCALE	0.0000	NONE

DATA HIST. CODE #6

BASIC LONGITUDINAL CHARACTERISTICS

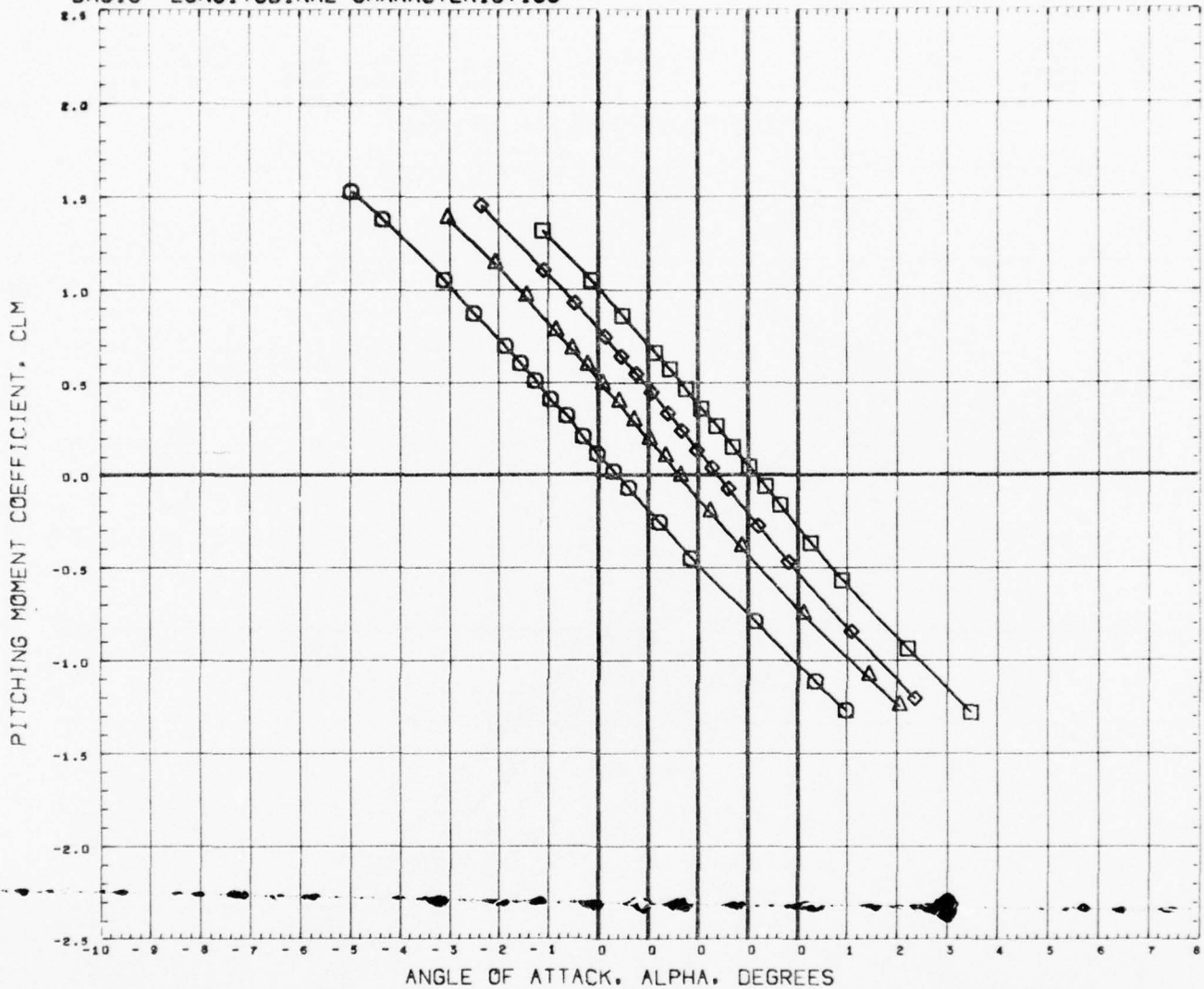

SYMBOL	MACH	PARAMETRIC VALUES			
○	1.052	PHI	0.000	M-LGTH	1.500
△	1.098	LS-LGH	5.250	S-WIDTH	0.200
◇	1.199	R-WIDTH	1.000		
□	1.300				

REFERENCE INFORMATION		
SREF	7.0686	INCHES
LREF	3.0000	INCHES
BREF	3.0000	INCHES
XNRP	0.0000	INCHES
YNRP	0.0000	INCHES
ZNRP	0.0000	INCHES
SCALE	0.0000	NONE

DATA HIST. CODE #G

BASIC LONGITUDINAL CHARACTERISTICS

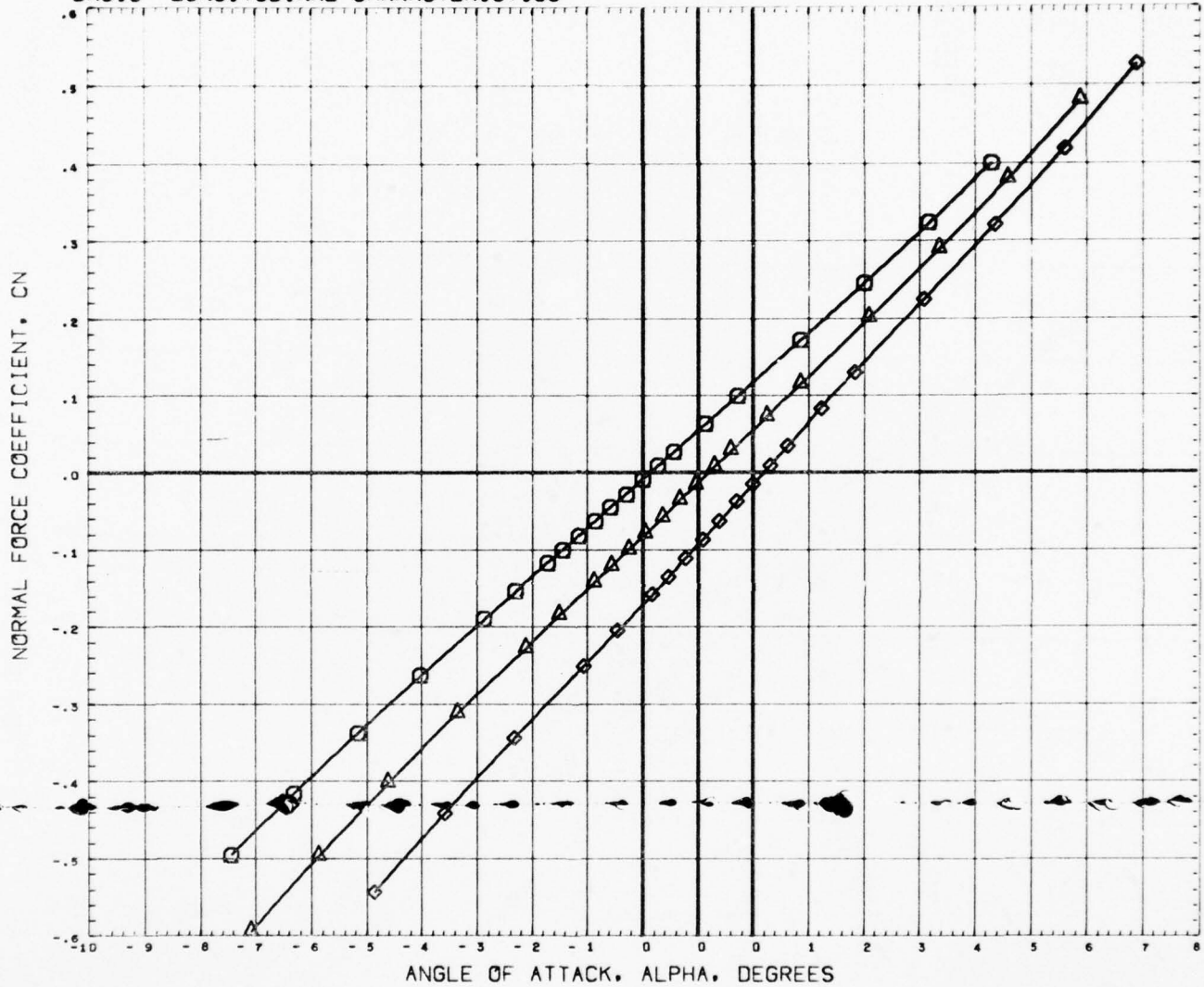

SYMBOL	MACH	PARAMETRIC VALUES
○	0.800	PHI 22.500 M-LGTH 1.500
△	1.001	LS-LGH 3.250 S-WDTH 0.200
◇	1.197	R-WDTH 1.000

REFERENCE INFORMATION		
SREF	7.0686	50. IN.
LREF	3.0000	INCHES
BREF	3.0000	INCHES
XMRP	0.0000	INCHES
YMRP	0.0000	INCHES
ZMRP	0.0000	INCHES
SCALE	0.0000	NONE

REFERENCE FILE

BASIC LONGITUDINAL CHARACTERISTICS

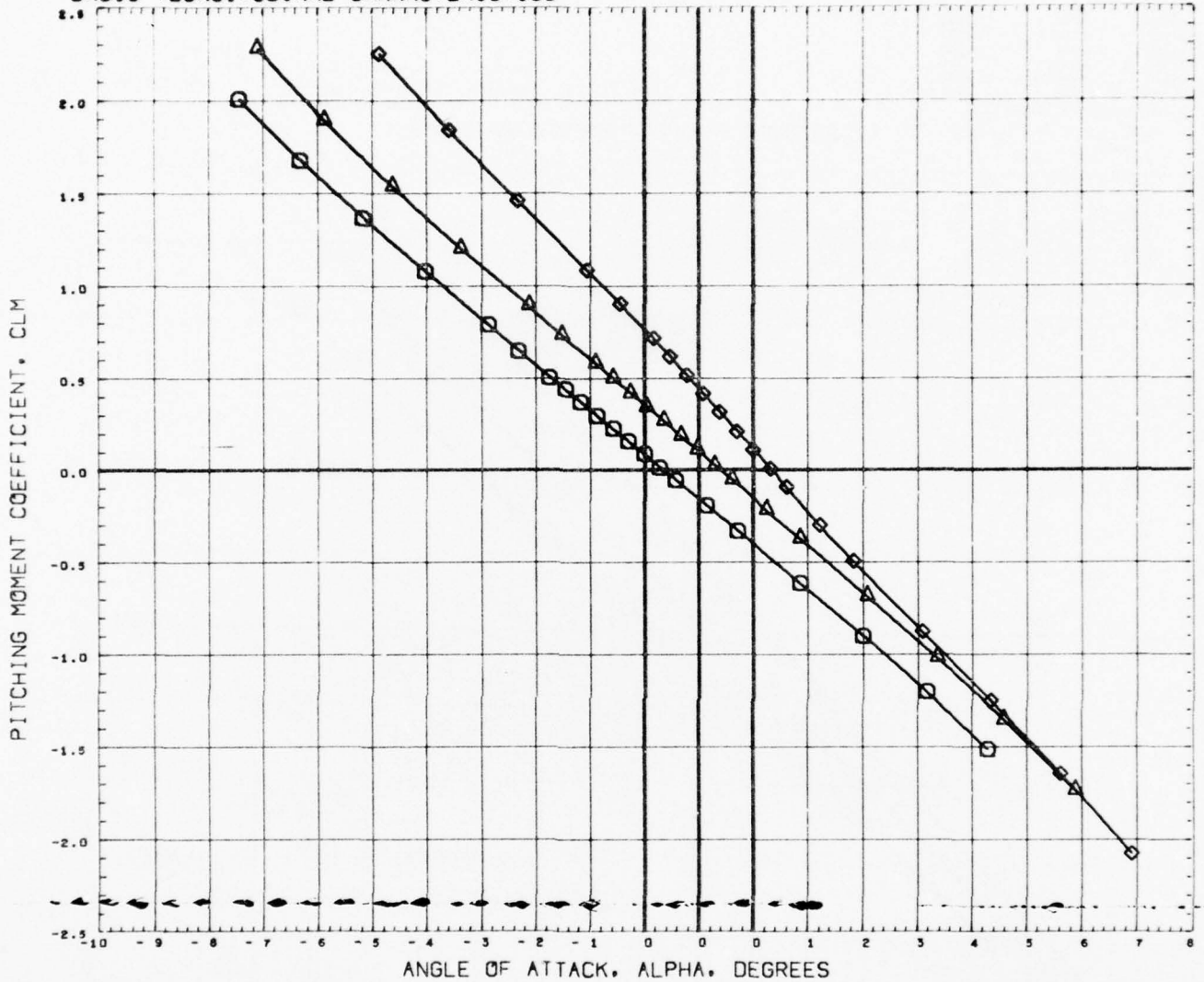

SYMBOL	MACH	PARAMETRIC VALUES			
○	0.800	PHI	22.500	M-LGTH	1.500
△	1.001	LS-LGH	3.250	S-WDTH	0.200
◇	1.197	R-WDTH	1.000		

REFERENCE INFORMATION		
SREF	7.0686	SQ. IN.
LREF	3.0000	INCHES
BREF	3.0000	INCHES
XMRP	0.0000	INCHES
YMRP	0.0000	INCHES
ZMRP	0.0000	INCHES
SCALE	0.0000	NONE

REFERENCE FILE

BASIC LONGITUDINAL CHARACTERISTICS

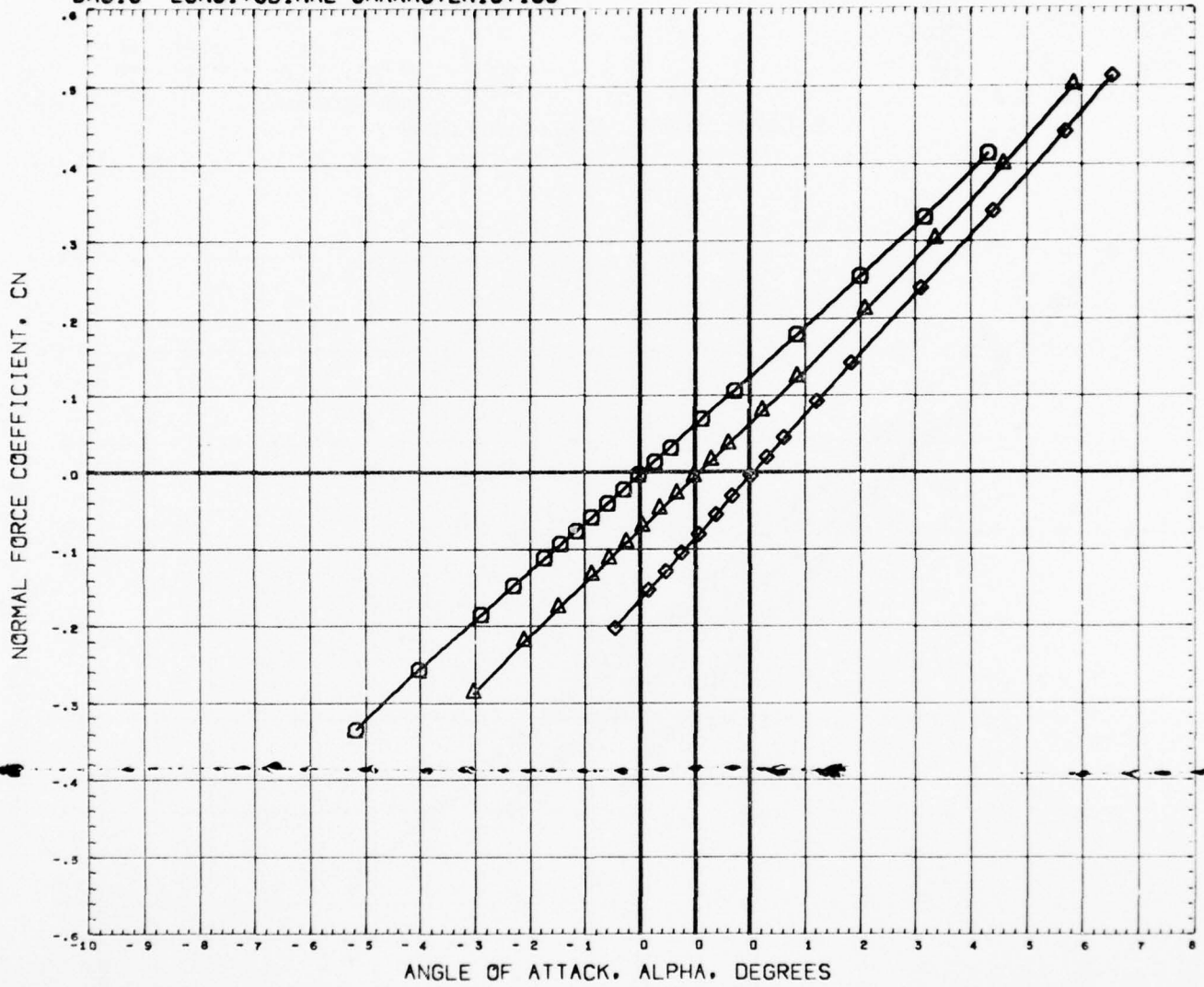

SYMBOL	MACH	PARAMETRIC VALUES			
○	0.800	PHI	45.000	M-LGTH	1.500
△	1.001	LS-LGH	3.250	S-WDTH	0.200
◇	1.198	R-WDTH	1.000		

REFERENCE INFORMATION		
SREF	7.0686	SQ. IN.
LREF	3.0000	INCHES
BREF	3.0000	INCHES
XMRP	0.0000	INCHES
YMRP	0.0000	INCHES
ZMRP	0.0000	INCHES
SCALE	0.0000	NONE

REFERENCE FILE

AEDC TEST PWT-4T201 CONE-CYL. W/RING TAIL, N1R2 (RTAR04) 10 MAR 72 PAGE 59

BASIC LONGITUDINAL CHARACTERISTICS

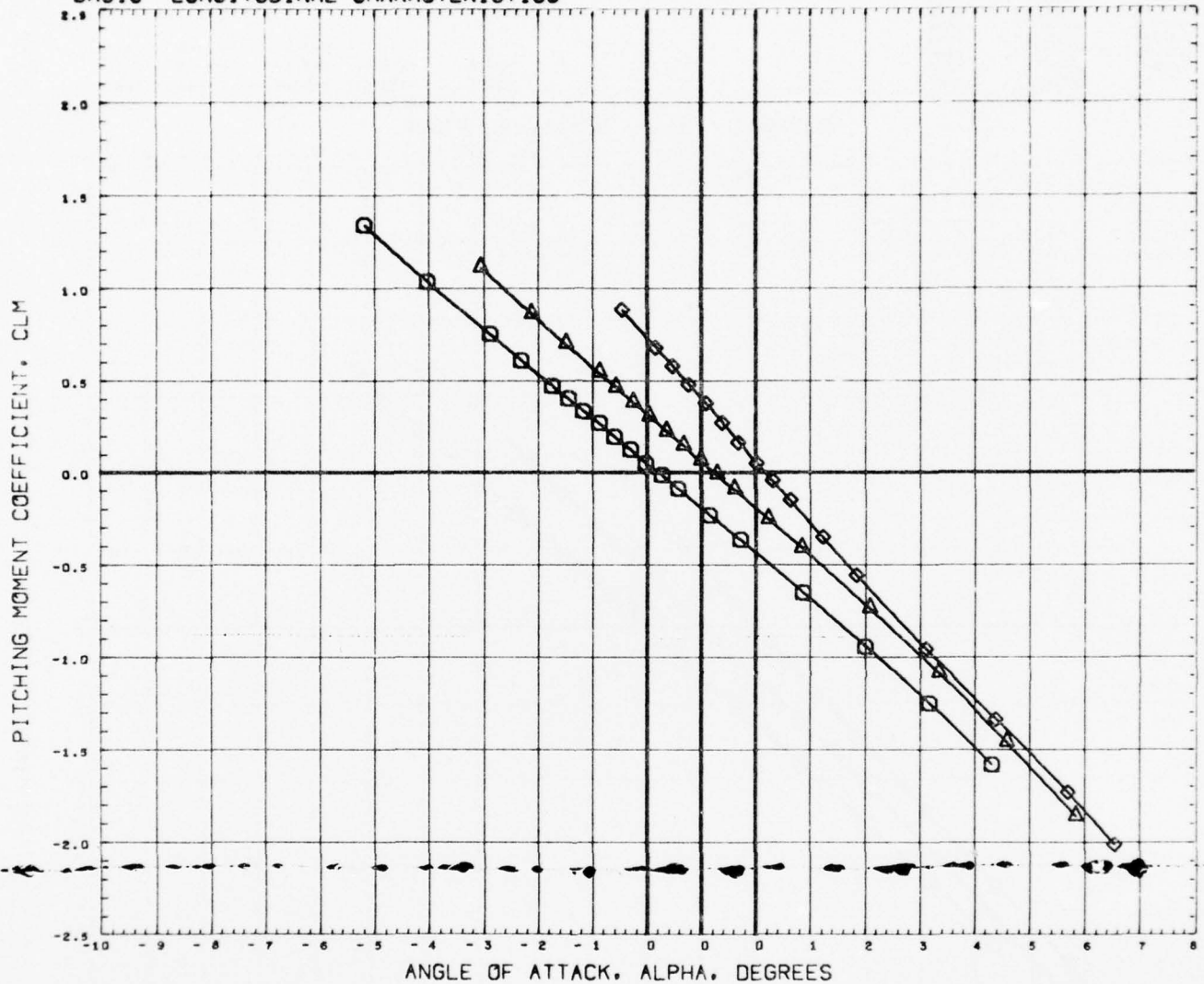

SYMBOL	MACH	PARAMETRIC VALUES				REFERENCE INFORMATION		
○	0.800	PHI	45.000	M-LGTH	1.500	SREF	7.0686	50. IN.
△	1.001	LS-LGM	3.250	S-WDTH	0.200	LREF	3.0000	INCHES
◇	1.198	R-WDTH	1.000			BREF	3.0000	INCHES
						XMRP	0.0000	INCHES
						YMRP	0.0000	INCHES
						ZMRP	0.0000	INCHES
						SCALE	0.0000	NONE

REFERENCE FILE

BASIC LONGITUDINAL CHARACTERISTICS

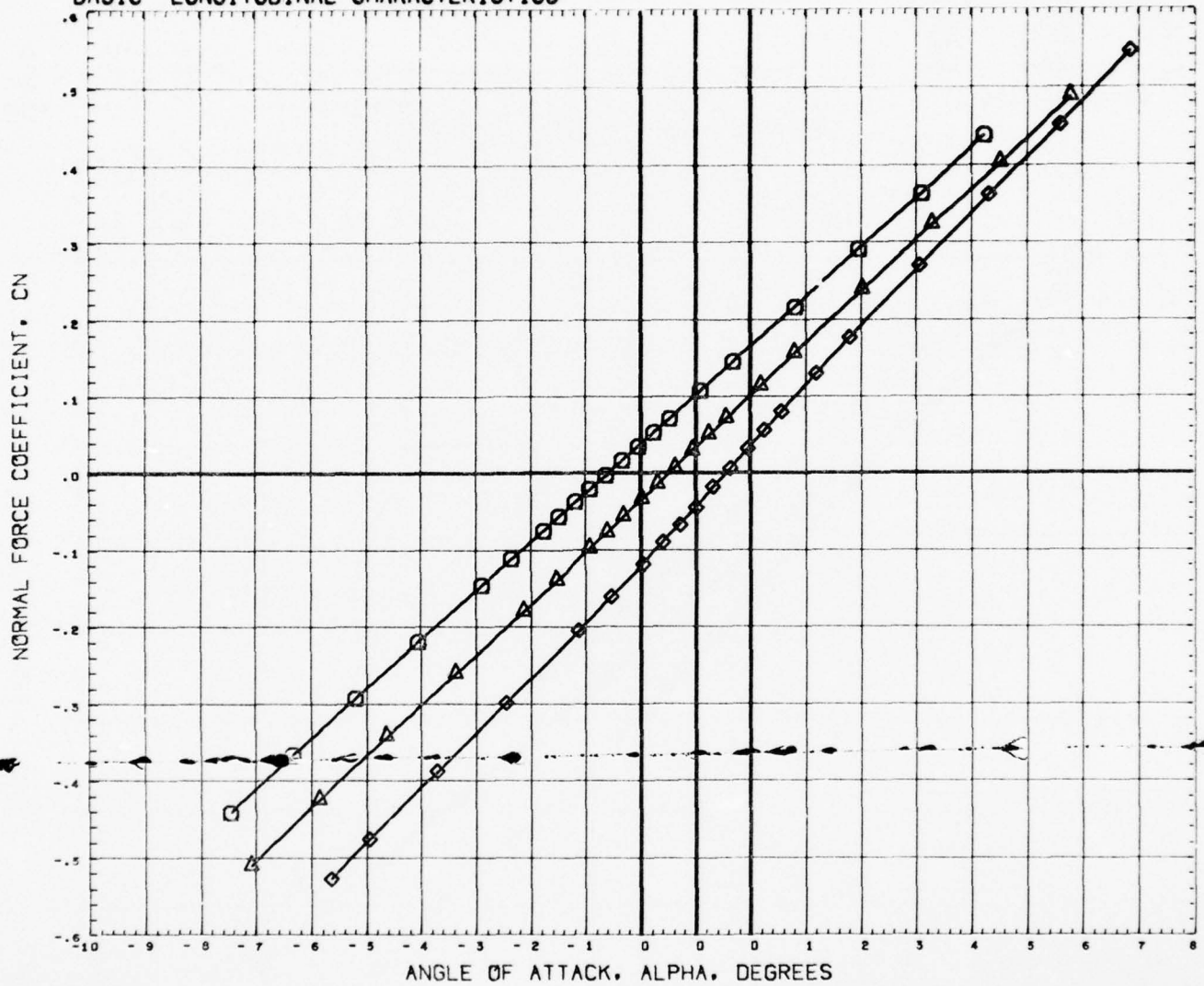

SYMBOL	MACH	PARAMETRIC VALUES			
○	0.801	PHI	180.000	M-LGTH	1.500
△	1.001	LS-LGH	3.250	S-WDTH	0.200
◇	1.198	R-WDTH	1.000		

REFERENCE INFORMATION		
SREF	7.0686	SQ. IN.
LREF	3.0000	INCHES
BREF	3.0000	INCHES
XMRP	0.0000	INCHES
YMRP	0.0000	INCHES
ZMRP	0.0000	INCHES
SCALE	0.0000	NONE

REFERENCE FILE

BASIC LONGITUDINAL CHARACTERISTICS

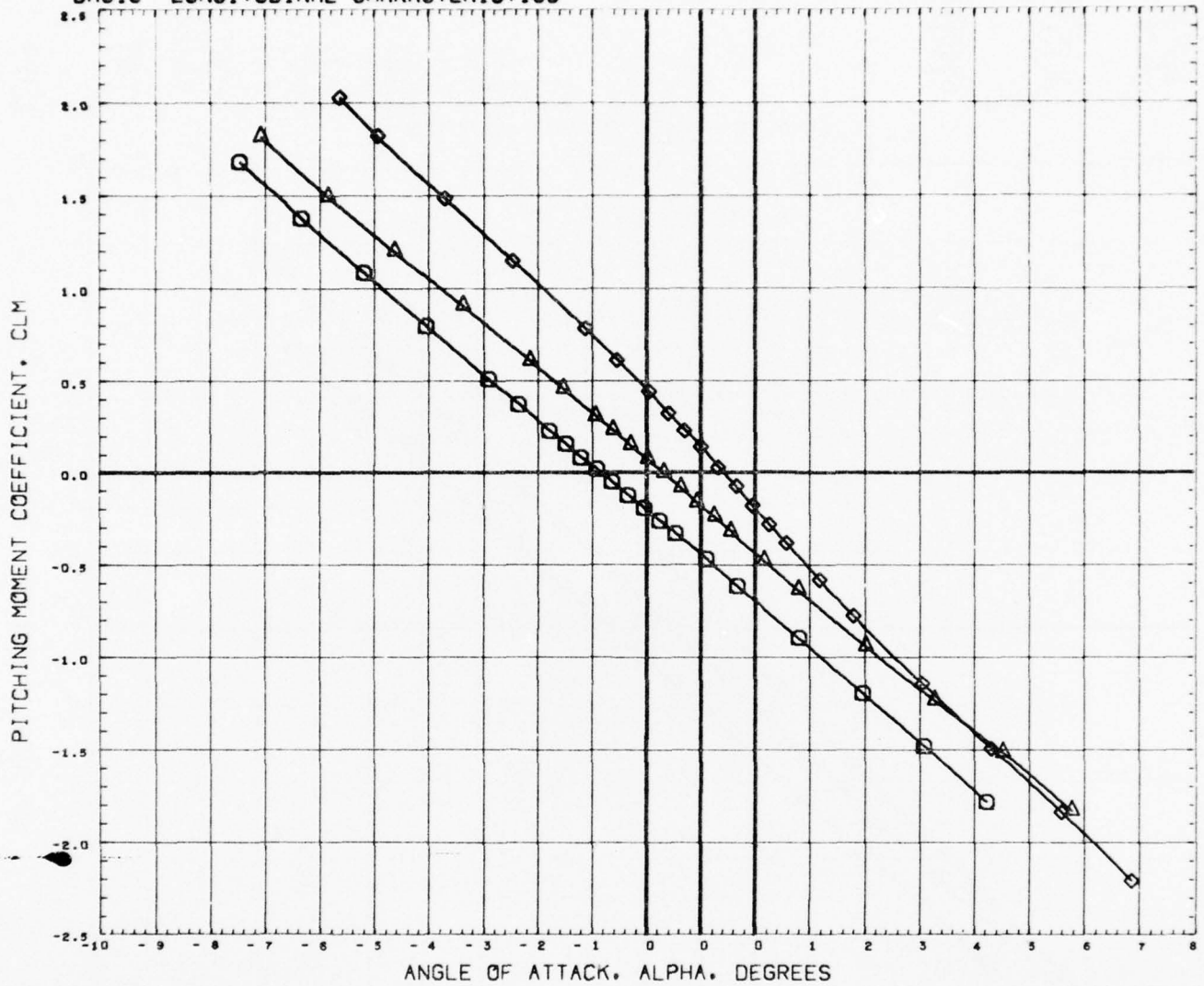

SYMBOL	MACH	PHI	PARAMETRIC VALUES		
○	0.801		180.000	M-LGTH	1.500
△	1.001	LS-LGH	3.250	S-WDTH	0.200
◇	1.198	R-WDTH	1.000		

REFERENCE INFORMATION		
SREF	7.0686	SQ. IN.
LREF	3.0000	INCHES
BREF	3.0000	INCHES
XMRP	0.0000	INCHES
YMRP	0.0000	INCHES
ZMRP	0.0000	INCHES
SCALE	0.0000	NONE

REFERENCE FILE

BASIC LONGITUDINAL CHARACTERISTICS

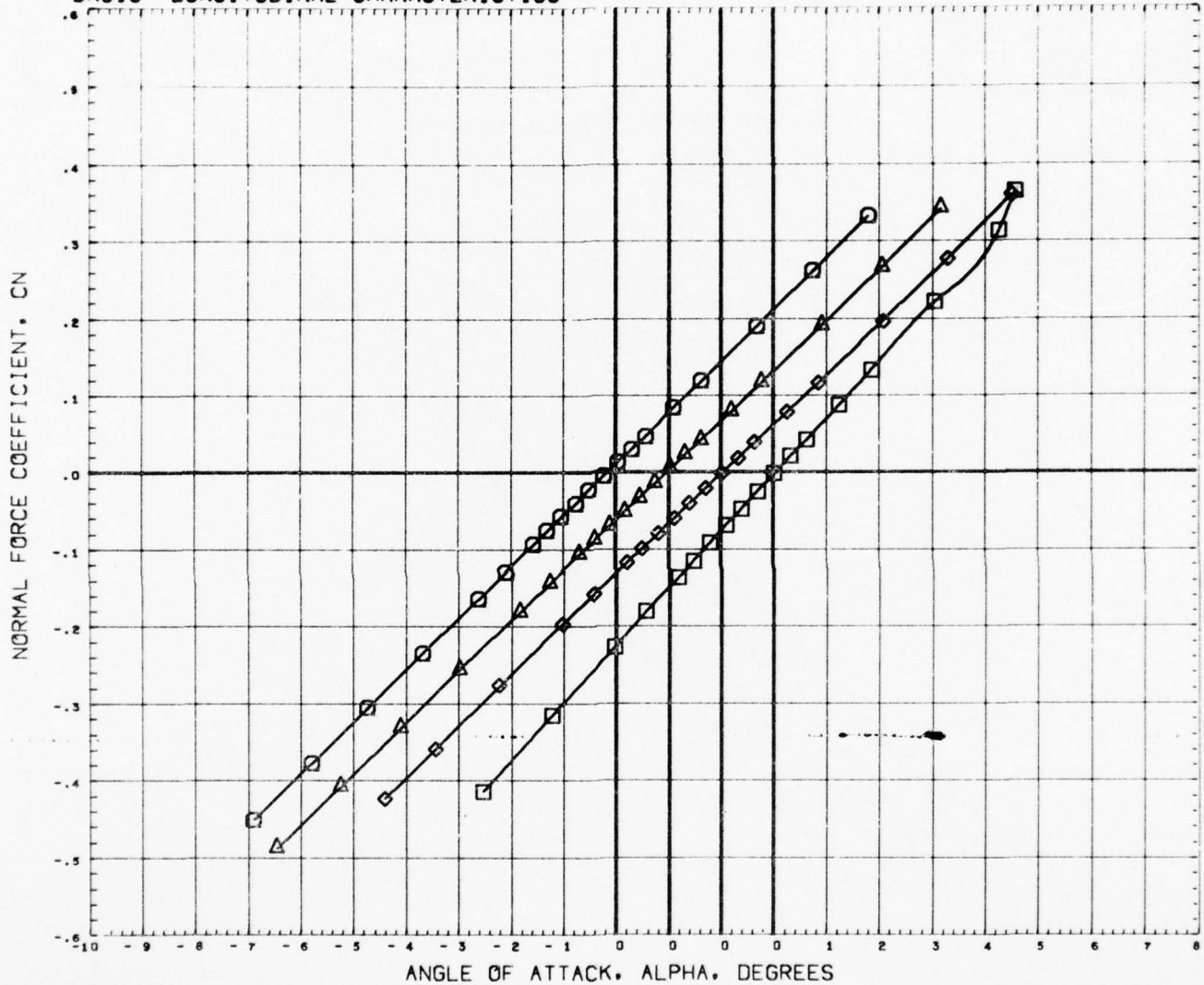

SYMBOL	MACH	PARAMETRIC VALUES				REFERENCE INFORMATION		
○	0.499	PHI	0.000	M-LGTH	0.750	SREF	7.0686	SQ. IN.
△	0.800	LS-LGH	4.000	S-WIDTH	0.200	LREF	3.0000	INCHES
◇	0.952	R-WIDTH	1.000			BREF	3.0000	INCHES
□	1.001					XMRP	0.0000	INCHES
						YMRP	0.0000	INCHES
						ZMRP	0.0000	INCHES
						SCALE	0.0000	NONE

REFERENCE FILE

BASIC LONGITUDINAL CHARACTERISTICS

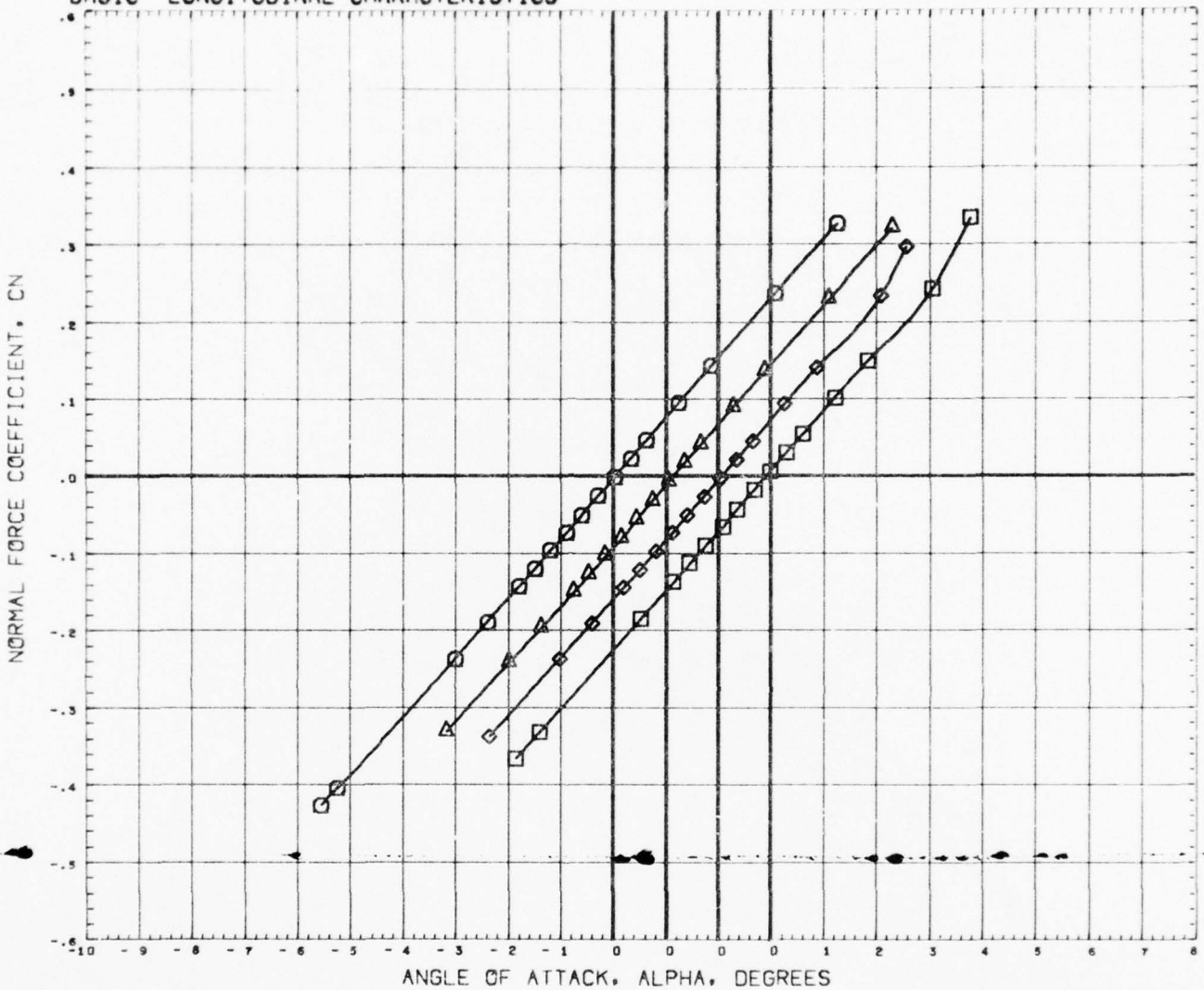

SYMBOL	MACH	PARAMETRIC VALUES				REFERENCE INFORMATION		
○	1.049	PHI	0.000	M-LGTH	0.750	SREF	7.0686	SQ. IN.
△	1.100	LS-LGH	4.000	S-WDTH	0.200	LREF	3.0000	INCHES
◇	1.197	R-WDTH	1.000			BREF	3.0000	INCHES
□	1.297					XMRP	0.0000	INCHES
						YMRP	0.0000	INCHES
						ZMRP	0.0000	INCHES
						SCALE	0.0000	NONE

REFERENCE FILE

BASIC LONGITUDINAL CHARACTERISTICS

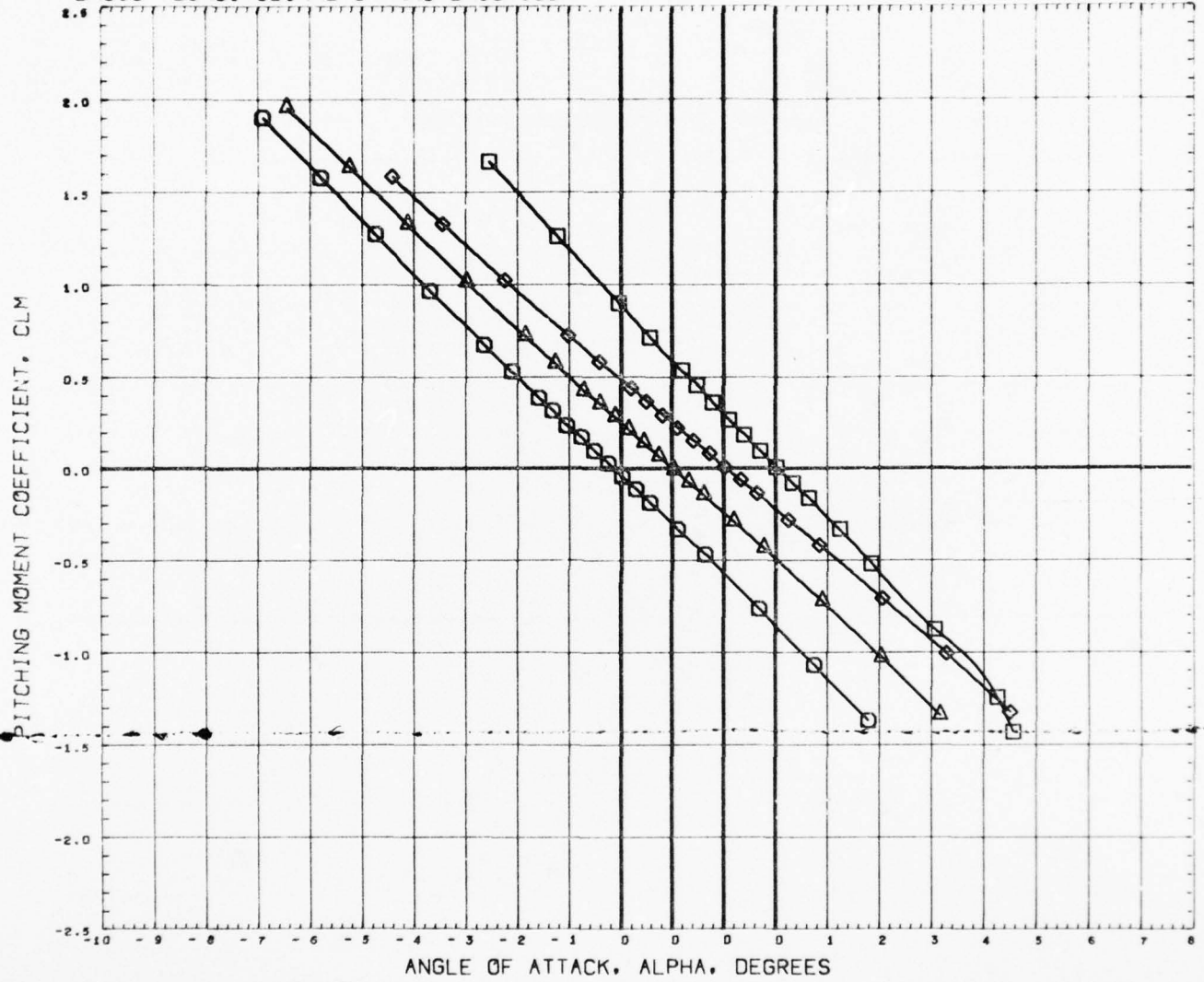

SYMBOL	MACH	PARAMETRIC VALUES				REFERENCE INFORMATION		
○	0.499	PHI	0.000	M-LGTH	0.750	SREF	7.0686	SQ. IN.
△	0.800	LS-LGH	4.000	S-WDTH	0.200	LREF	3.0000	INCHES
◇	0.952	R-WDTH	1.000			BREF	3.0000	INCHES
□	1.001					XMRP	0.0000	INCHES
						YMRP	0.0000	INCHES
						ZMRP	0.0000	INCHES
						SCALE	0.0000	NONE

REFERENCE FILE

BASIC LONGITUDINAL CHARACTERISTICS

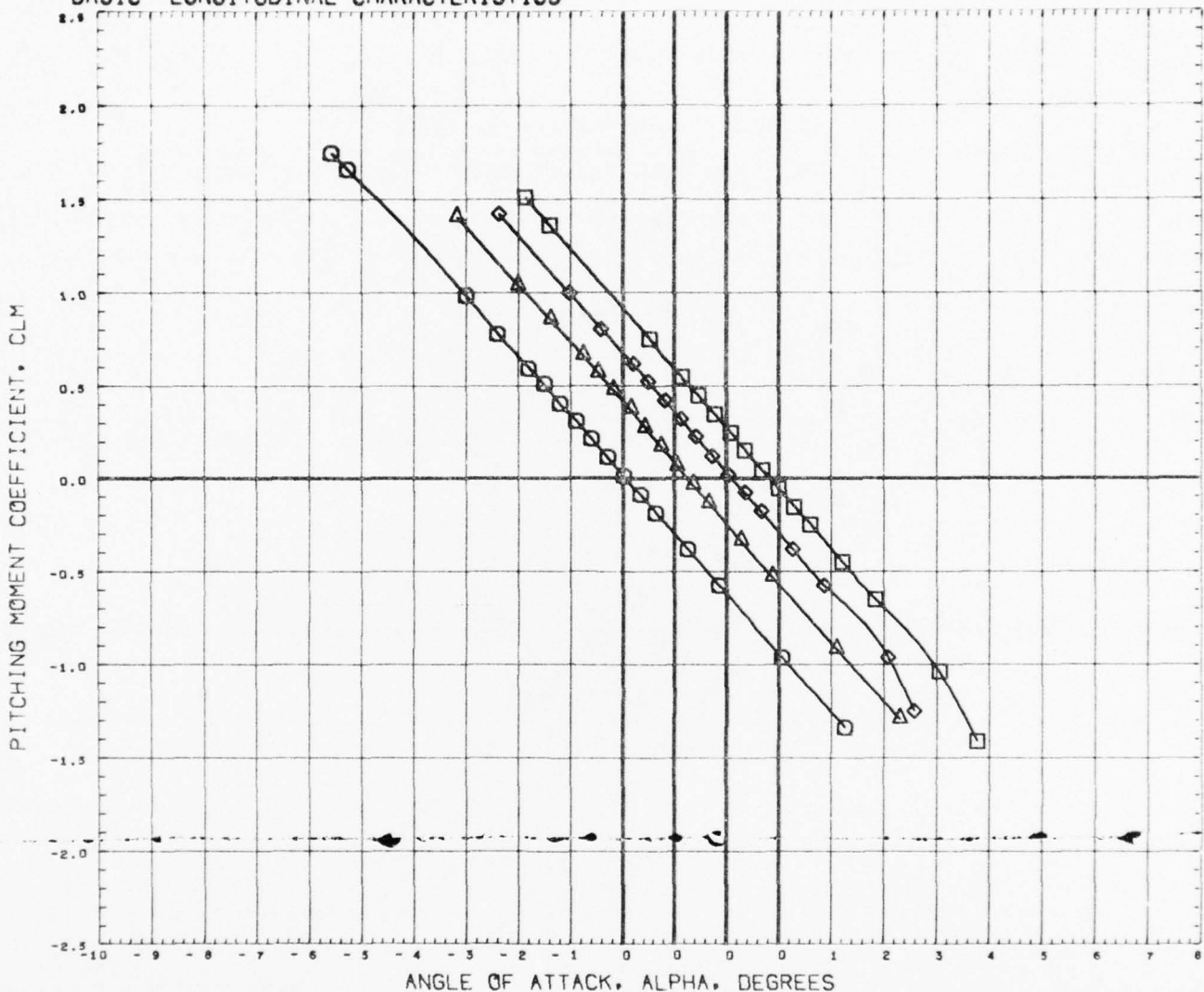

SYMBOL	MACH	PARAMETRIC VALUES				REFERENCE INFORMATION	
		PHI	M-LGTH	S-WDTH	SREF	SQ. IN.	
○	1.049	0.000	0.750		7.0686		
△	1.100	4.000	0.200		3.0000	INCHES	
◇	1.197	R-WDTH	1.000		3.0000	INCHES	
□	1.297				0.0000	INCHES	
					0.0000	INCHES	
					0.0000	INCHES	
					0.0000	INCHES	
					0.0000	NONE	

REFERENCE FILE

BASIC LONGITUDINAL CHARACTERISTICS

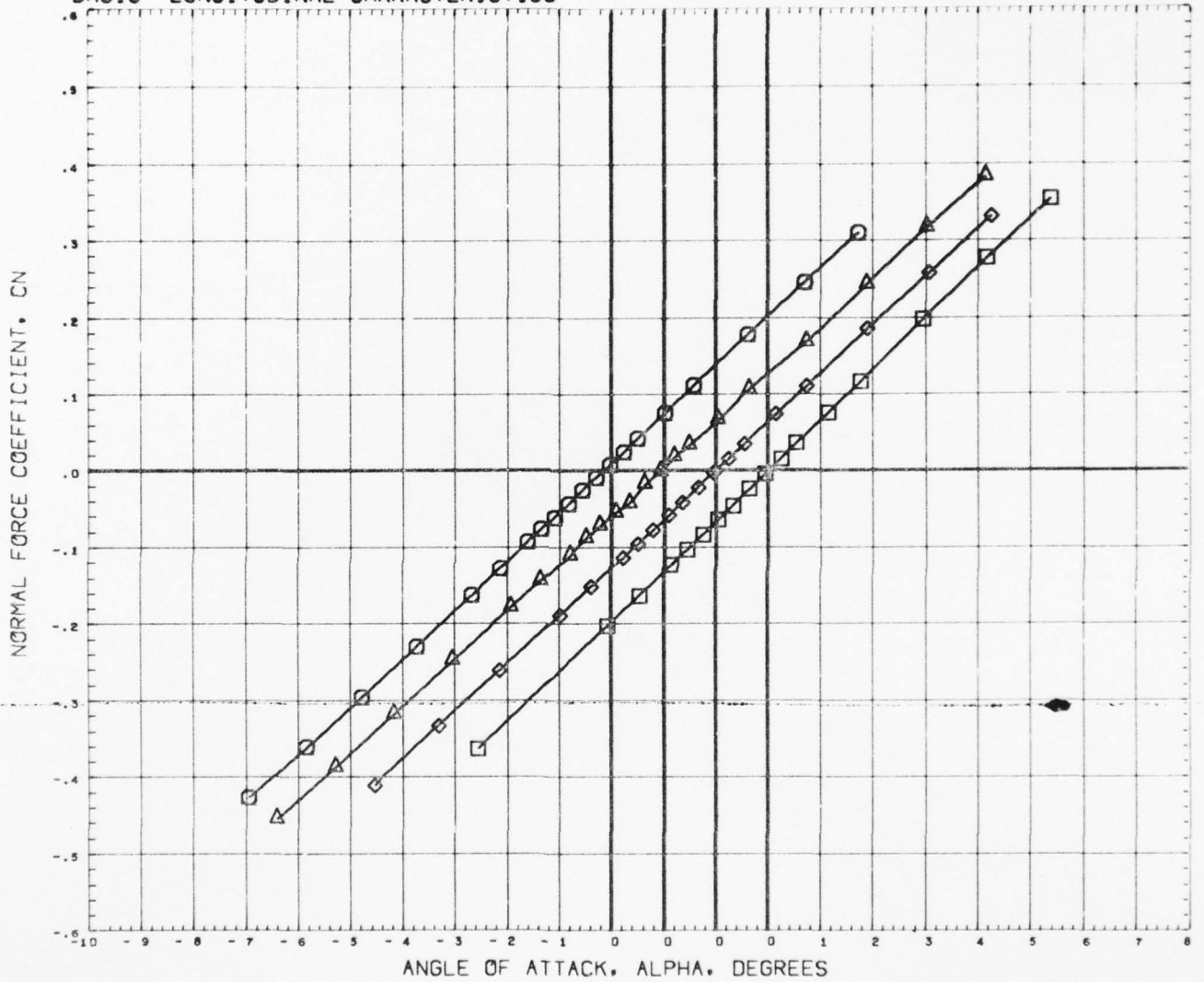

SYMBOL	MACH	PARAMETRIC VALUES				REFERENCE INFORMATION		
○	0.500	PHI	0.000	M-LGTH	2.250	SREF	7.0686	SQ. IN.
△	0.799	LS-LGH	3.000	S-WDTH	0.200	LREF	3.0000	INCHES
◇	0.948	R-WDTH	1.000			BREF	3.0000	INCHES
□	1.000					XMRP	0.0000	INCHES
						YMRP	0.0000	INCHES
						ZMRP	0.0000	INCHES
						SCALE	0.0000	NONE

REFERENCE FILE

BASIC LONGITUDINAL CHARACTERISTICS

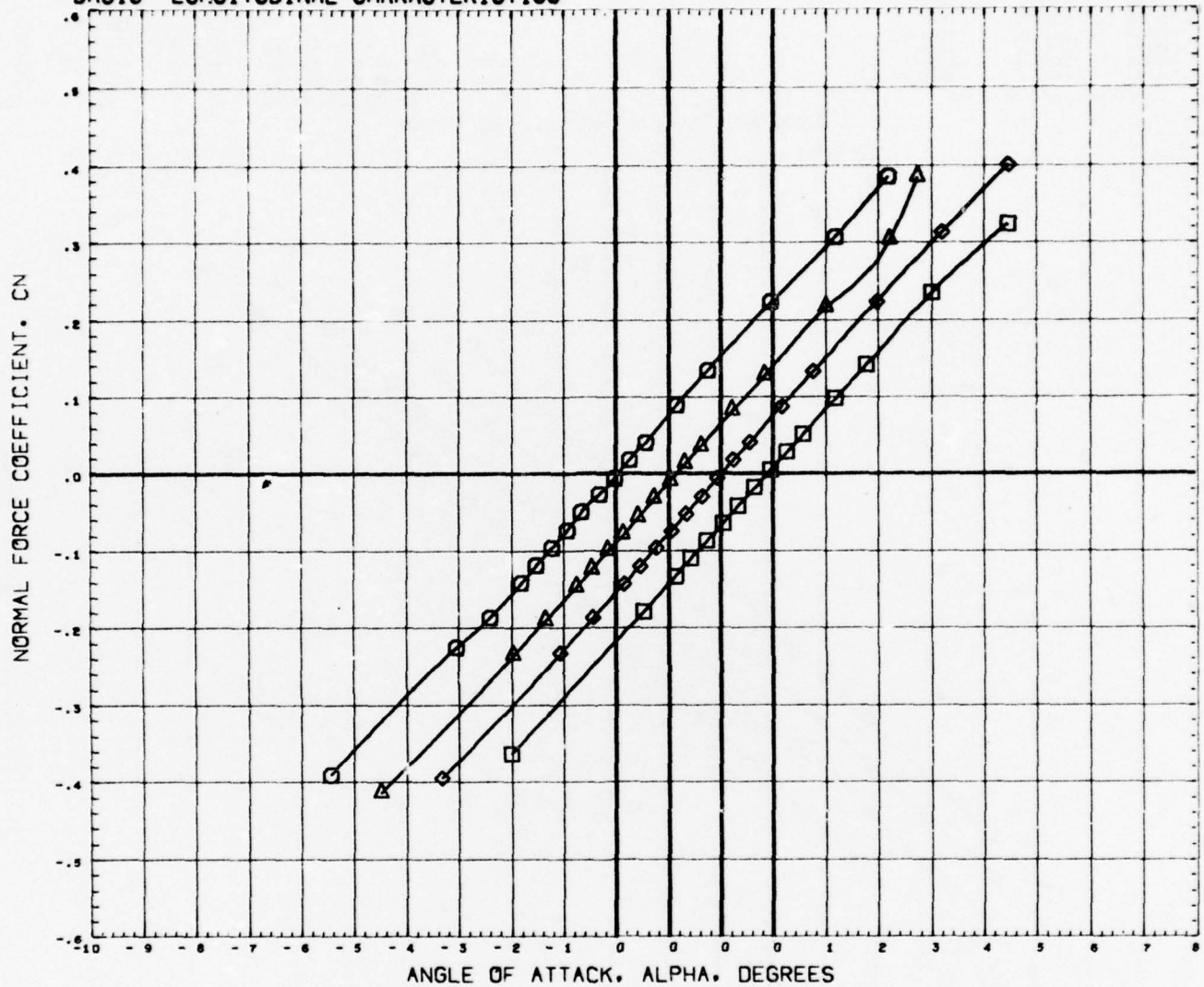

SYMBOL	MACH	PARAMETRIC VALUES				REFERENCE INFORMATION		
○	1.048	PHI	0.000	M-LGTH	2.250	SREF	7.0686	50. IN.
△	1.100	LS-LGM	5.000	S-WDTH	0.200	LREF	3.0000	INCHES
◇	1.197	R-WDTH	1.000			BREF	3.0000	INCHES
□	1.298					XMRP	0.0000	INCHES
						YMRP	0.0000	INCHES
						ZMRP	0.0000	INCHES
						SCALE	0.0000	NONE

REFERENCE FILE

BASIC LONGITUDINAL CHARACTERISTICS

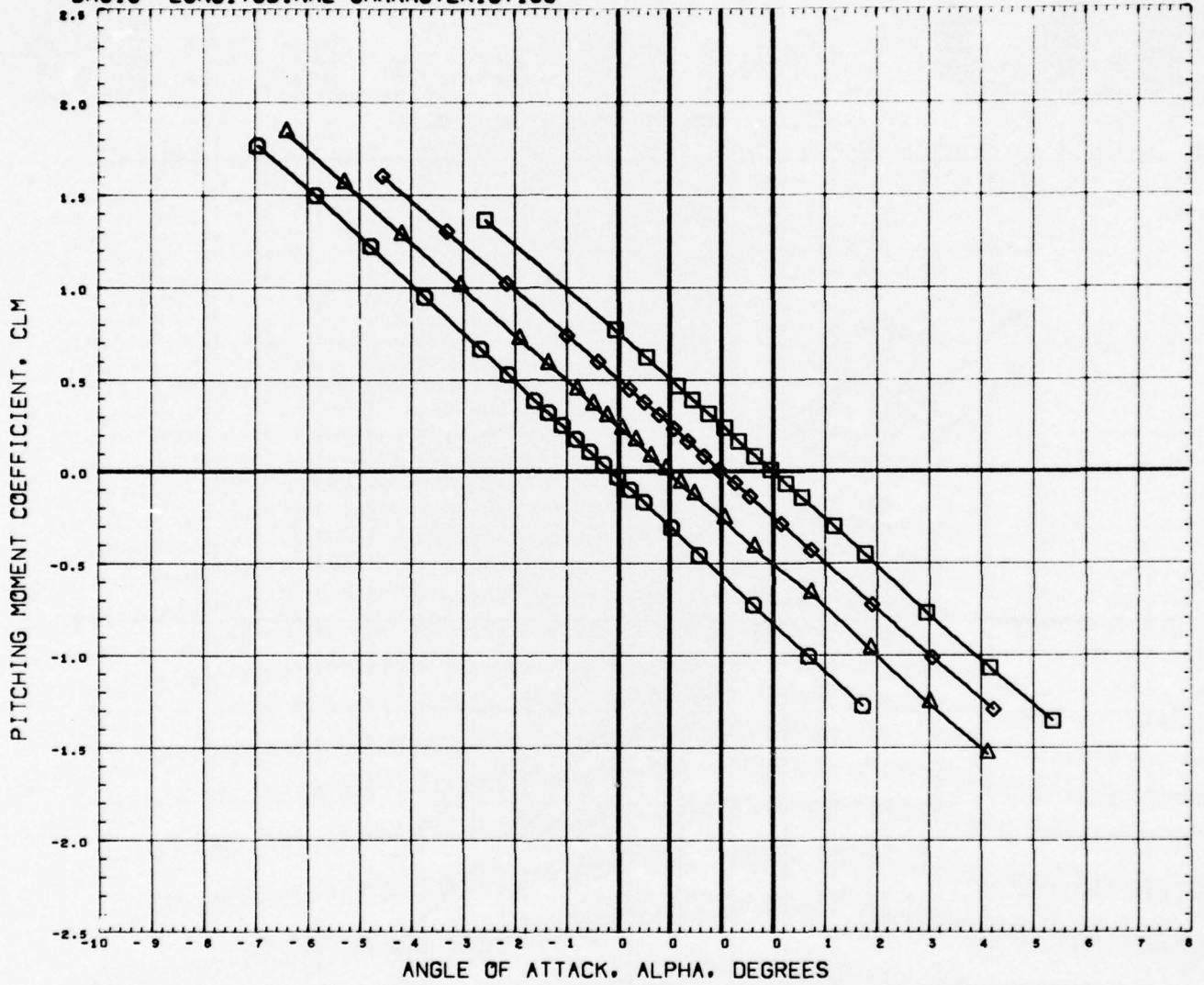

SYMBOL	MACH	PARAMETRIC VALUES				REFERENCE INFORMATION		
○	0.500	PHI	0.000	M-LGTH	2.250	SREF	7.0686	59. IN.
△	0.799	LS-LGM	3.000	S-WDTH	0.200	LREF	3.0000	INCHES
◇	0.948	R-WDTH	1.000			BREF	3.0000	INCHES
□	1.000					XMRP	0.0000	INCHES
						YMRP	0.0000	INCHES
						ZMRP	0.0000	INCHES
						SCALE	0.0000	NONE

REFERENCE FILE

BASIC LONGITUDINAL CHARACTERISTICS

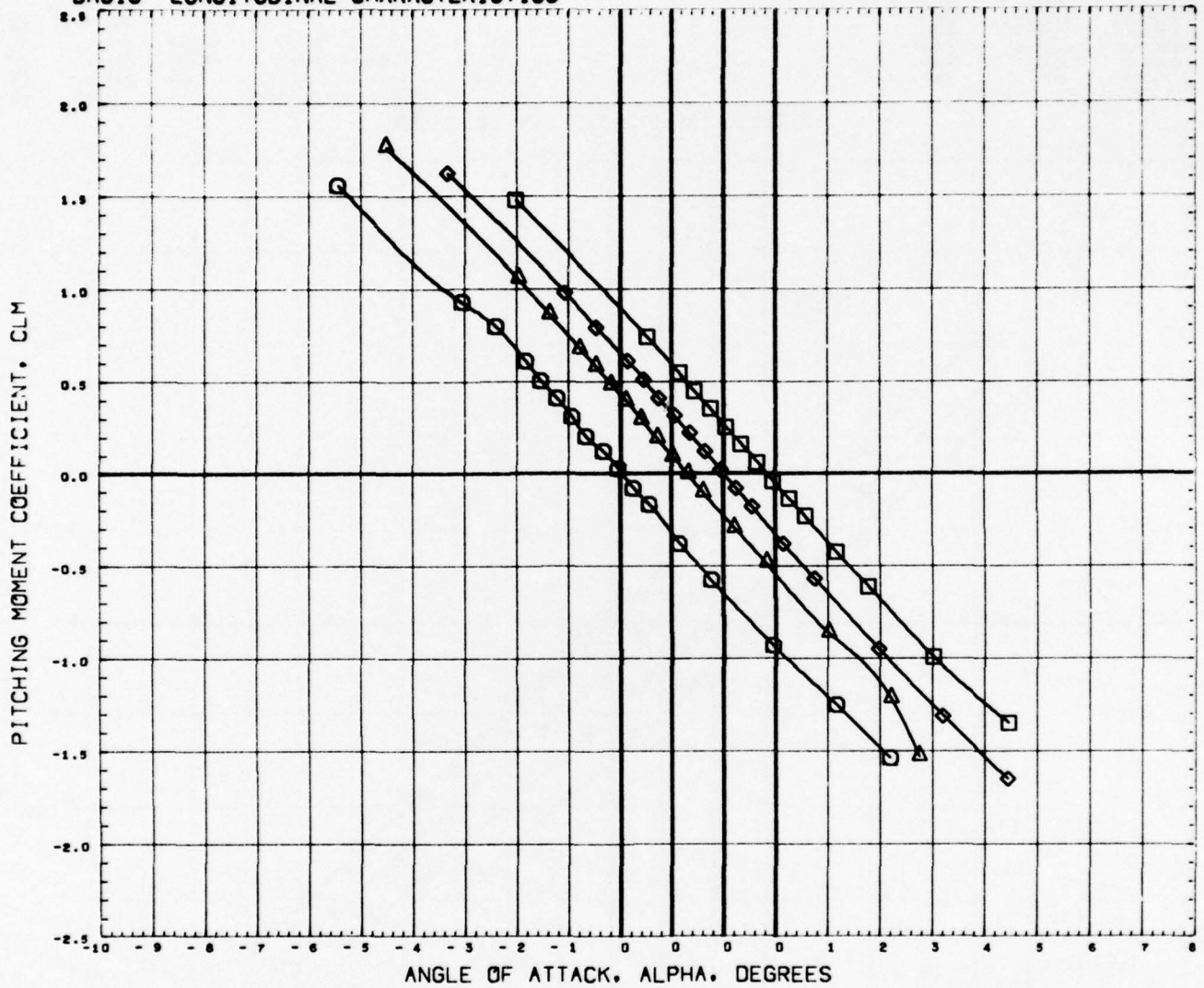

SYMBOL	MACH	PHI	PARAMETRIC VALUES		
○	1.048	0.000	M-LGTH	2.250	
△	1.100	LS-LGN	3.000	S-WDTH	0.200
◇	1.197	R-WDTH	1.000		
□	1.298				

REFERENCE INFORMATION		
SREF	7.0686	sq. in.
LREF	3.0000	INCHES
BREF	3.0000	INCHES
XMRP	0.0000	INCHES
YMRP	0.0000	INCHES
ZMRP	0.0000	INCHES
SCALE	0.0000	NONE

REFERENCE FILE

BASIC LONGITUDINAL CHARACTERISTICS

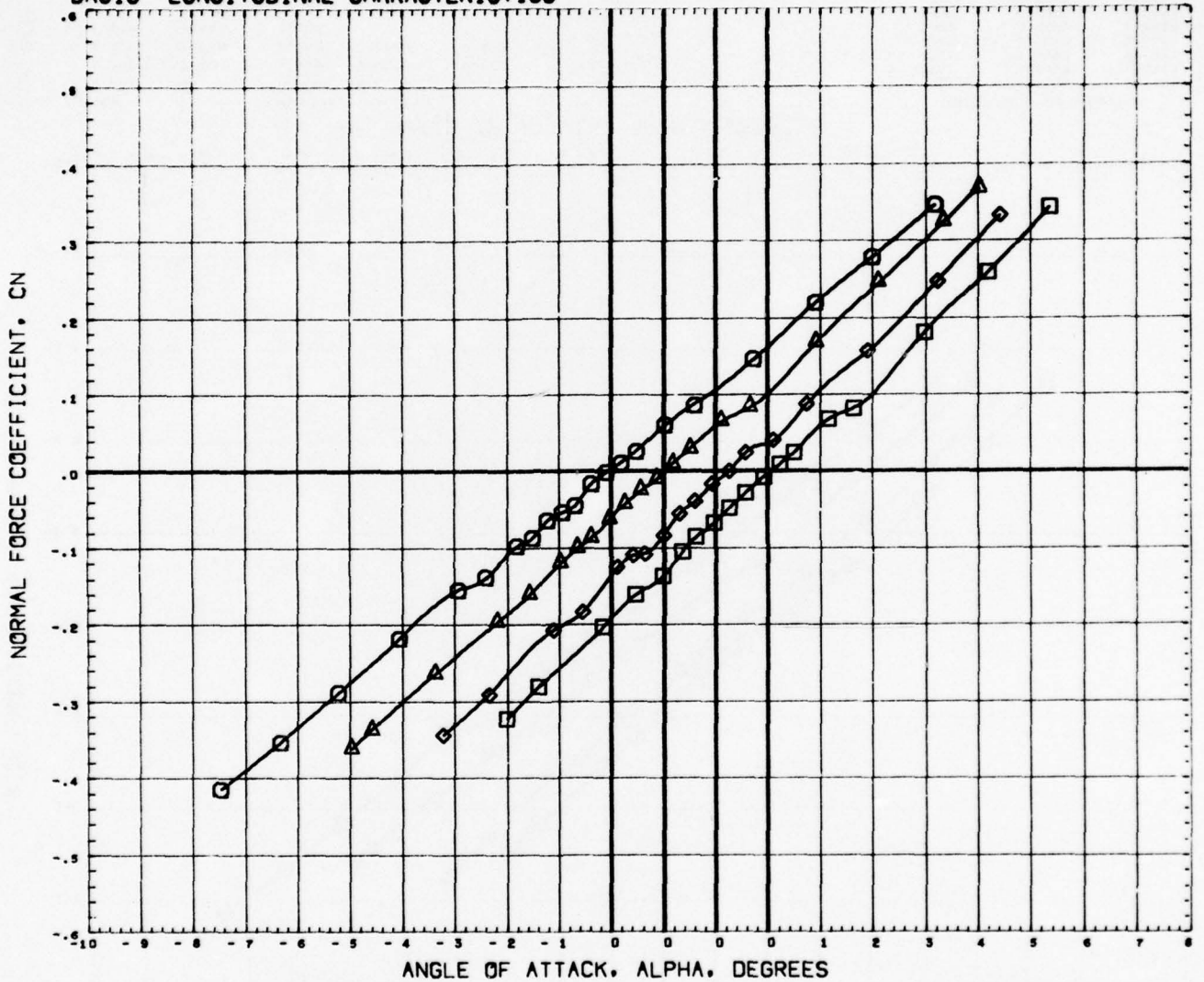

SYMBOL	MACH	PARAMETRIC VALUES				REFERENCE INFORMATION		
○	0.801	PHI	0.000	M-LGTH	2.250	SREF	7.0686	50. IN.
△	1.002	LS-LGH	2.500	S-WDTH	0.200	LREF	3.0000	INCHES
◇	1.100	R-WDTH	1.000	C-LGTH	5.000	BREF	3.0000	INCHES
□	1.199	C-DIA	0.500			XWRP	0.0000	INCHES
						YWRP	0.0000	INCHES
						ZWRP	0.0000	INCHES
						SCALE	0.0000	NONE

BASIC LONGITUDINAL CHARACTERISTICS

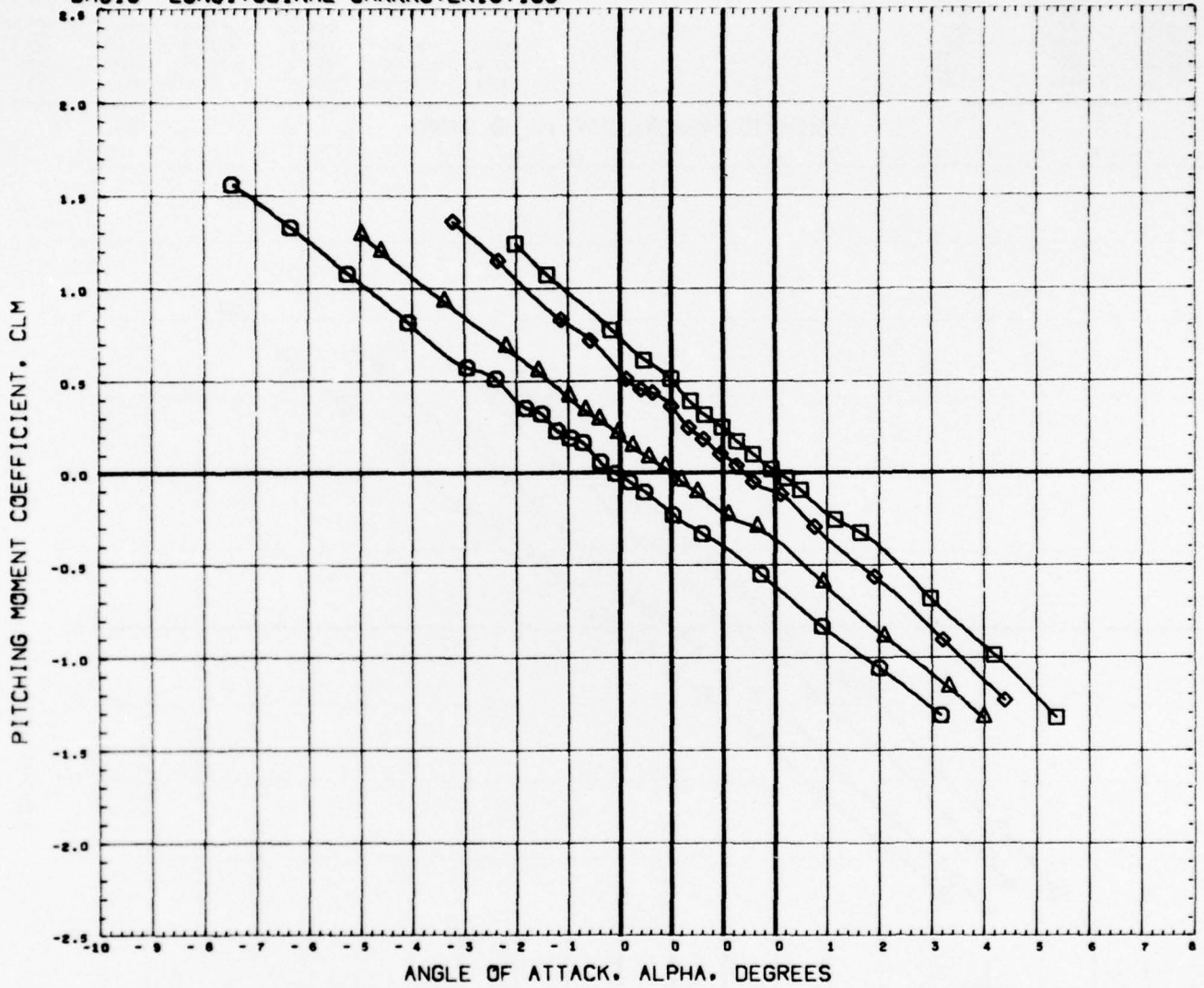

SYMBOL	MACH	PARAMETRIC VALUES				REFERENCE INFORMATION		
○	0.001	PHI	0.000	M-LGTH	2.250	SREF	7.0606	50. IN.
△	1.002	LS-LGM	2.500	S-WDTH	0.200	LREF	3.0000	INCHES
◇	1.100	R-WDTH	1.000	C-LGTH	5.000	BREF	3.0000	INCHES
□	1.199	C-DIA	0.500			XHRP	0.0000	INCHES
						YHRP	0.0000	INCHES
						ZHRP	0.0000	INCHES
						SCALE	0.0000	NONE

REFERENCE FILE

BASIC LONGITUDINAL CHARACTERISTICS

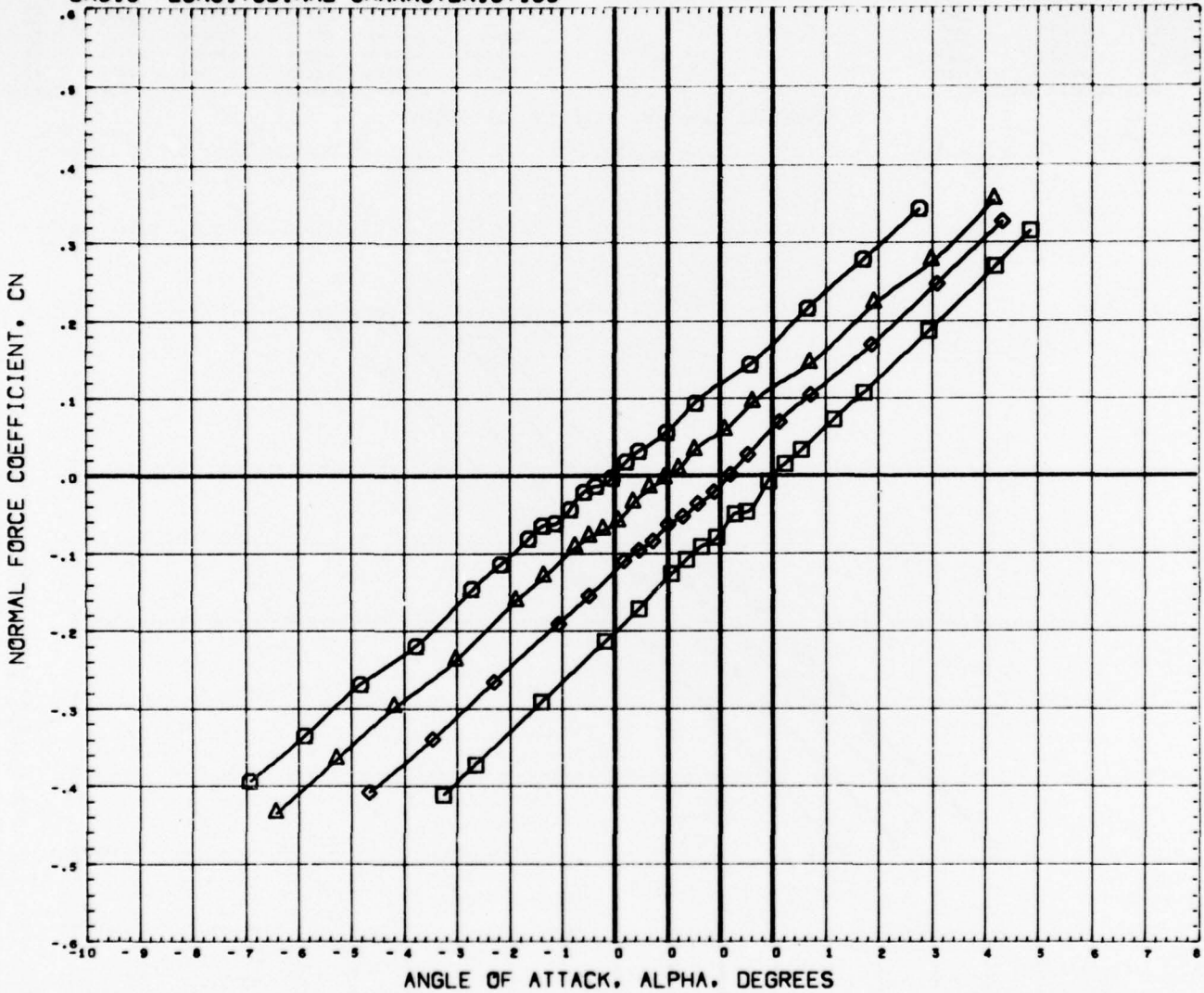

SYMBOL	MACH	PARAMETRIC VALUES				REFERENCE INFORMATION		
○	0.500	PHI	0.000	M-LGTH	1.500	SREF	7.0686	50. IN.
△	0.801	LS-LGH	3.250	S-WDTH	0.200	LREF	3.0000	INCHES
◇	0.947	R-WDTH	1.000	C-LGTH	5.000	BREF	3.0000	INCHES
□	1.002	C-DIA	0.400			XMRP	0.0000	INCHES
						YMRP	0.0000	INCHES
						ZMRP	0.0000	INCHES
						SCALE	0.0000	NONE

REFERENCE FILE

BASIC LONGITUDINAL CHARACTERISTICS

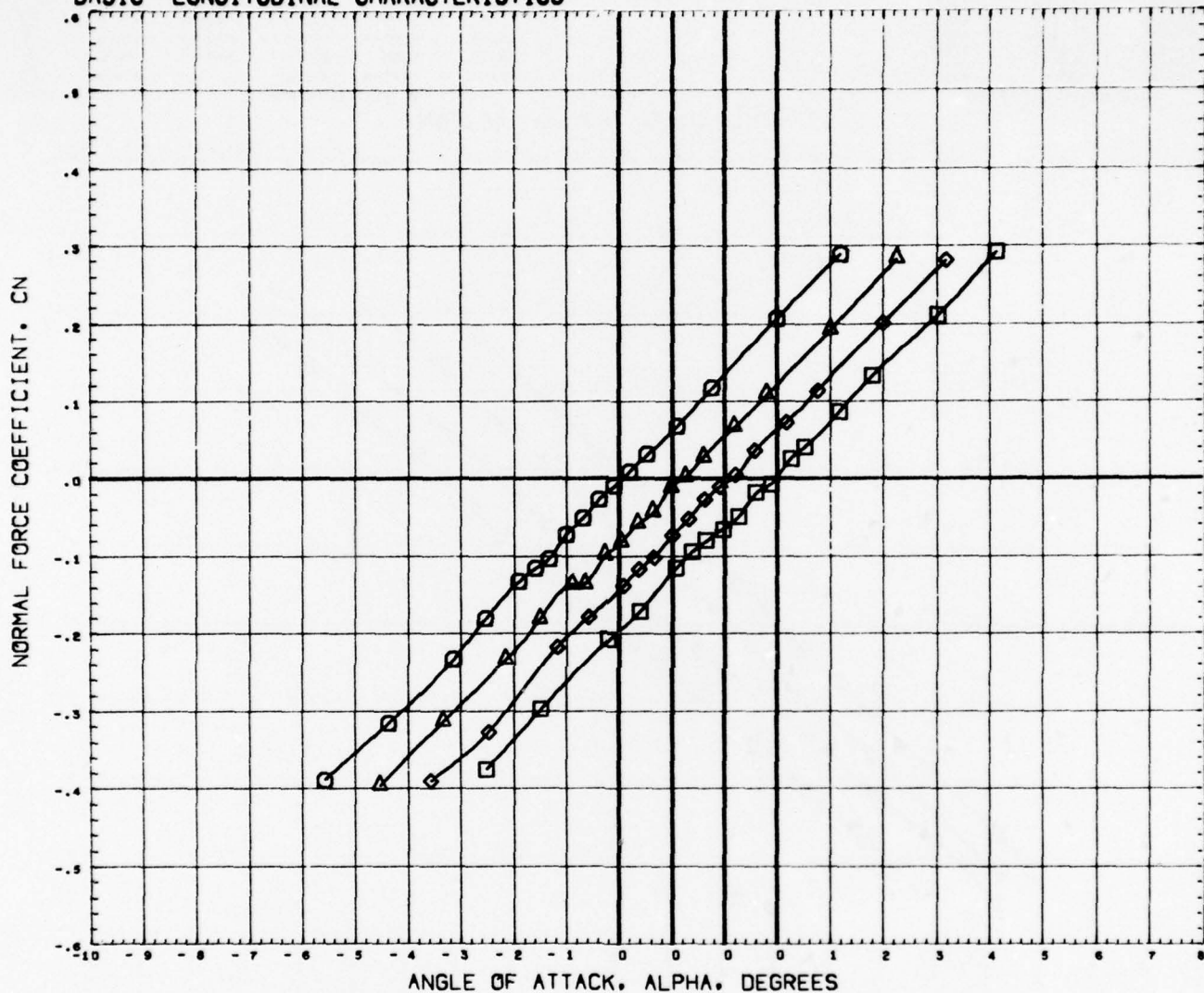

SYMBOL	MACH	PARAMETRIC VALUES
○	1.049	PHI 0.000 M-LGTH 1.500
△	1.102	LS-LGN 3.250 S-WDTH 0.200
◇	1.199	R-WDTH 1.000 C-LGTH 5.000
□	1.300	C-OIA 0.400

REFERENCE INFORMATION		
SREF	7.0686	50. IN.
LREF	3.0000	INCHES
BREF	3.0000	INCHES
XWRP	0.0000	INCHES
YWRP	0.0000	INCHES
ZWRP	0.0000	INCHES
SCALE	0.0000	NONE

REFERENCE FILE

BASIC LONGITUDINAL CHARACTERISTICS

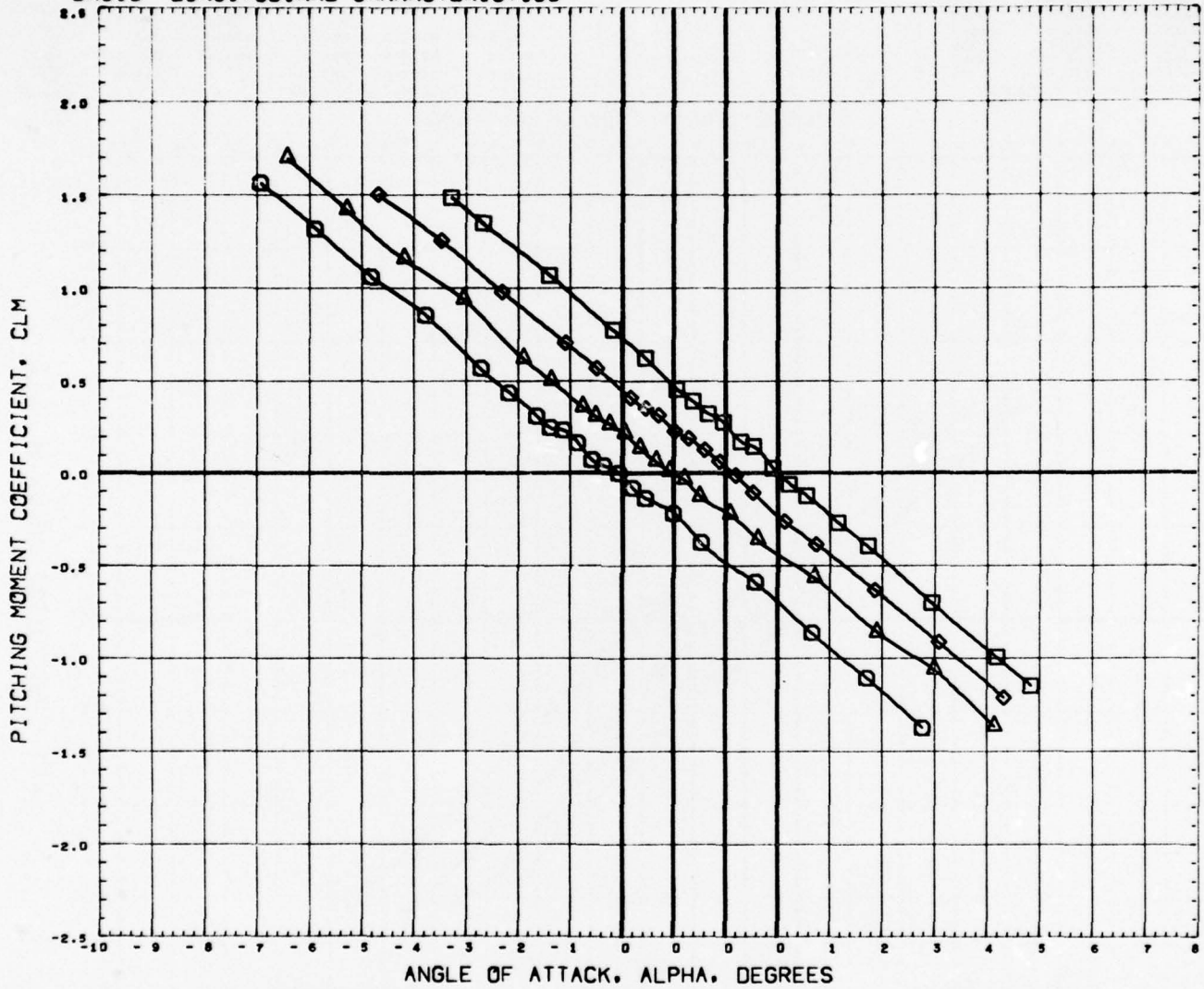

SYMBOL	MACH	PARAMETRIC VALUES			
○	0.500	PHI	0.000	M-LGTH	1.500
△	0.801	LS-LGH	3.250	S-WDTH	0.200
◇	0.947	R-WDTH	1.000	C-LGTH	5.000
□	1.002	C-DIA	0.400		

REFERENCE INFORMATION		
SREF	7.0686	50. IN.
LREF	3.0000	INCHES
BREF	3.0000	INCHES
XMRP	0.0000	INCHES
YMRP	0.0000	INCHES
ZMRP	0.0000	INCHES
SCALE	0.0000	NONE

REFERENCE FILE

BASIC LONGITUDINAL CHARACTERISTICS

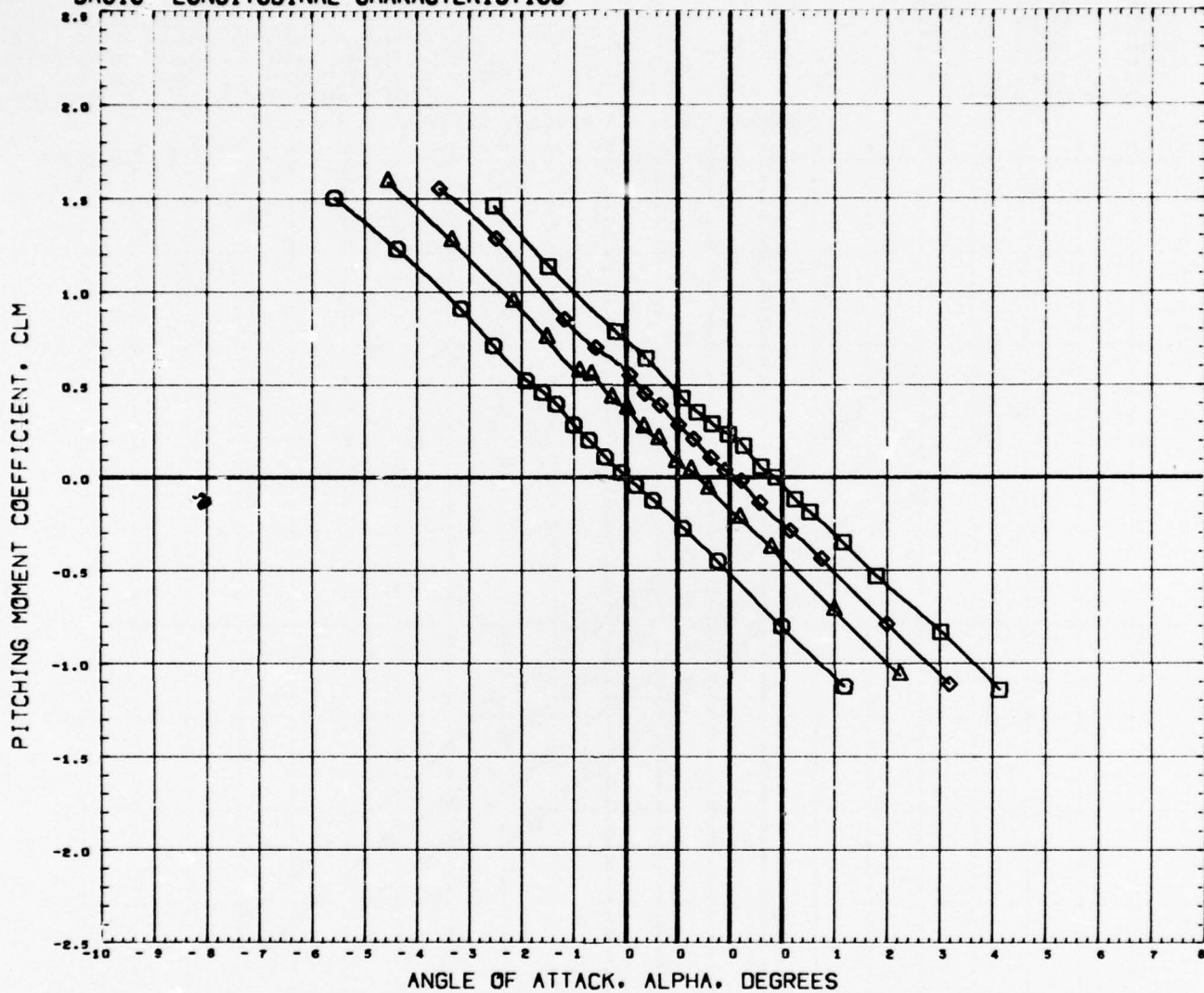

SYMBOL	MACH	PARAMETRIC VALUES				REFERENCE INFORMATION		
○	1.049	PHI	0.000	M-LGTH	1.500	SREF	7.0686	SQ. IN.
△	1.102	LS-LGM	3.250	S-WDTH	0.200	LREF	3.0000	INCHES
◇	1.199	R-WDTH	1.000	C-LGTH	5.000	BREF	3.0000	INCHES
□	1.300	C-DIA	0.400			XMRP	0.0000	INCHES
						YMRP	0.0000	INCHES
						ZMRP	0.0000	INCHES
						SCALE	0.0000	NONE

REFERENCE FILE

BASIC LONGITUDINAL CHARACTERISTICS

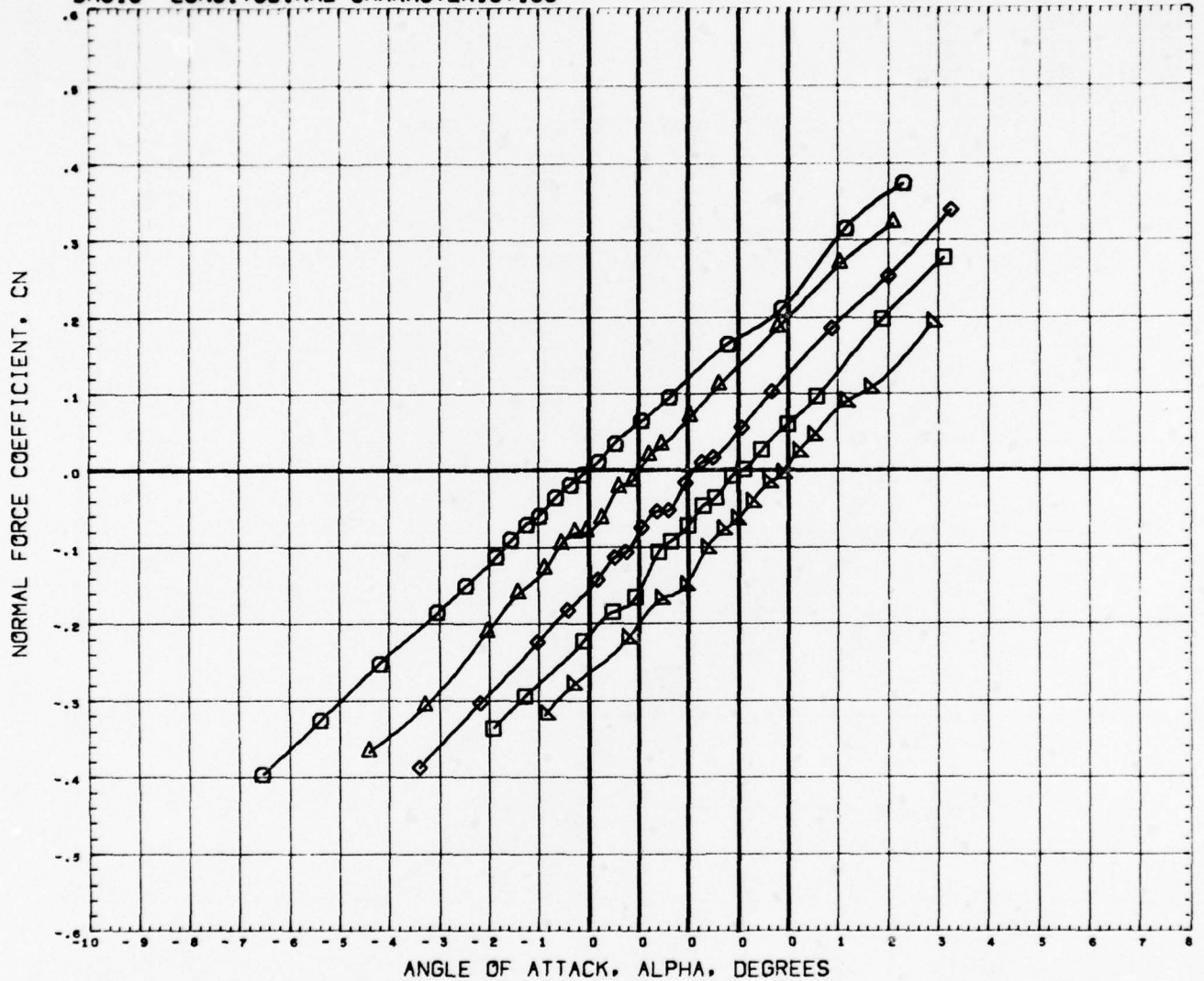

SYMBOL	MACH	PARAMETRIC VALUES				REFERENCE INFORMATION		
○	0.949	PHI	0.000	M-LGTH	2.250	SREF	7.0686	SQ. IN.
△	1.005	LS-LGH	3.000	S-WDTH	0.200	LREF	3.0000	INCHES
◇	1.099	R-WDTH	1.000	C-LGTH	5.000	BREF	3.0000	INCHES
□	1.198	C-DIA	0.400			XMRP	0.0000	INCHES
△	1.296					YMRP	0.0000	INCHES
						ZMRP	0.0000	INCHES
						SCALE	0.0000	NONE

REFERENCE FILE

BASIC LONGITUDINAL CHARACTERISTICS

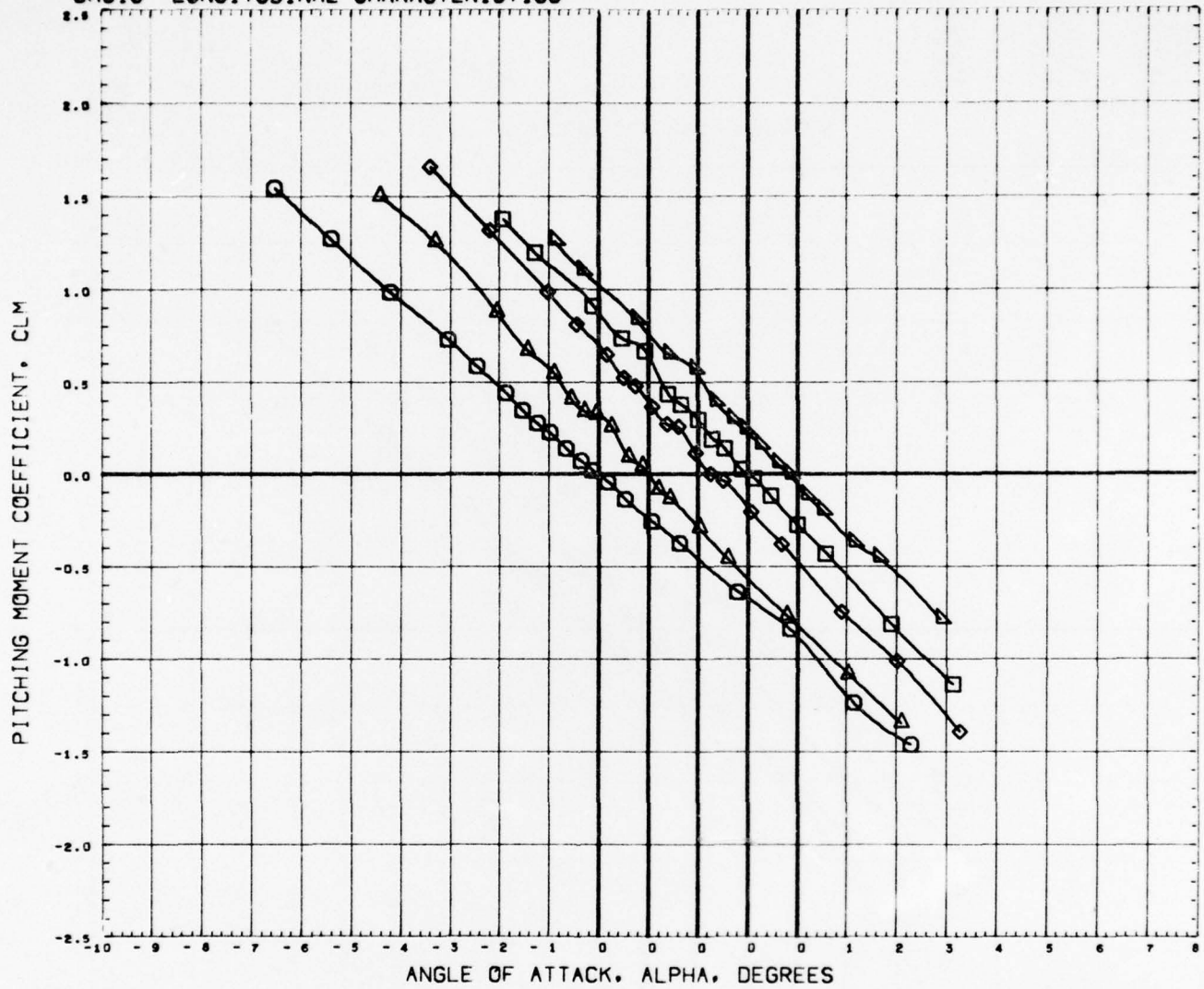

SYMBOL	MACH	PARAMETRIC VALUES				REFERENCE INFORMATION		
○	0.949	PHI	0.000	M-LGTH	2.250	SREF	7.0686	SQ. IN.
△	1.005	LS-LGH	3.000	S-WDTH	0.200	LREF	3.0000	INCHES
□	1.099	R-WDTH	1.000	C-LGTH	5.000	BREF	3.0000	INCHES
◇	1.198	C-DIA	0.400			XMRF	0.0000	INCHES
×	1.296					YMRF	0.0000	INCHES
						ZMRF	0.0000	INCHES
						SCALE	0.0000	NONE

REFERENCE FILE

BASIC LONGITUDINAL CHARACTERISTICS

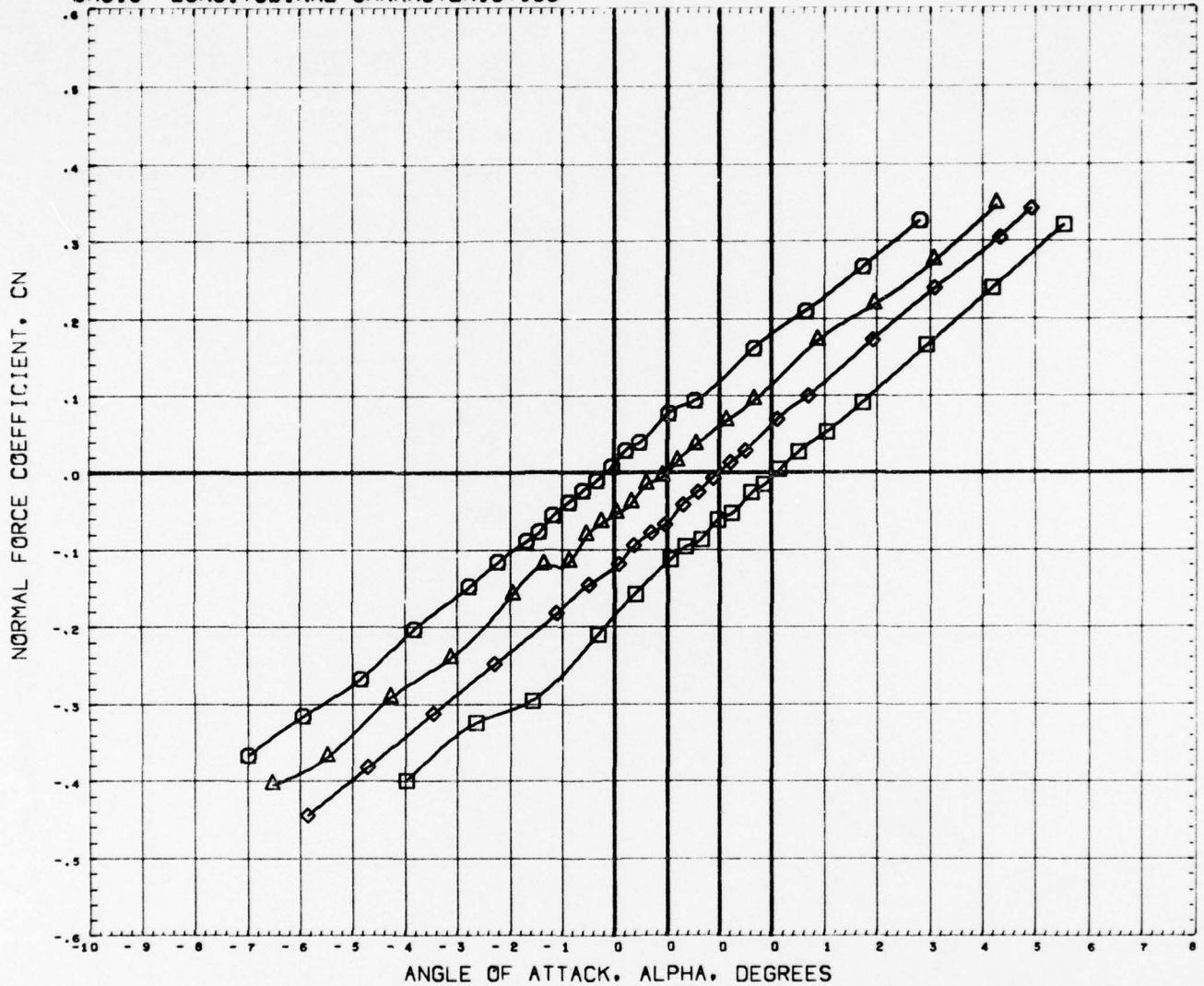

SYMBOL	MACH	PHI	PARAMETRIC VALUES			REFERENCE INFORMATION		
○	0.499	0.000	M-LGTH	2.250	SREF	7.0686	SQ. IN.	
△	0.801	2.500	LS-LGM	0.400	LREF	3.0000	INCHES	
◇	0.957	1.000	R-WDTH	5.000	BREF	3.0000	INCHES	
□	1.000	0.400	C-LGTH		XWRP	0.0000	INCHES	
					YWRP	0.0000	INCHES	
					ZWRP	0.0000	INCHES	
					SCALE	0.0000	NONE	

REFERENCE FILE

BASIC LONGITUDINAL CHARACTERISTICS

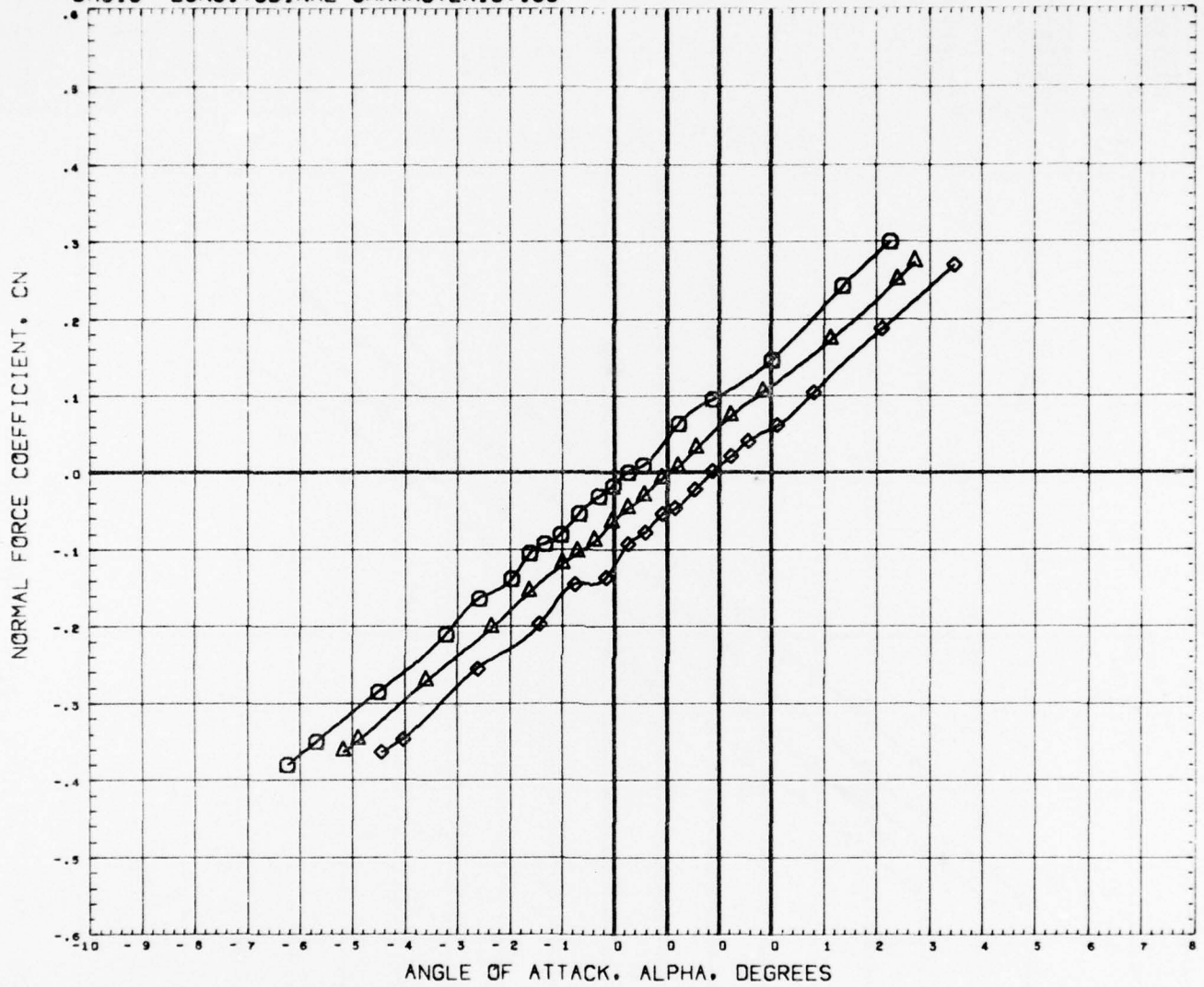

SYMBOL	MACH	PHI	PARAMETRIC VALUES		
○	1.102	0.000	M-LGTH	2.250	
△	1.197	2.500	S-WDTH	0.400	
◇	1.298	1.000	C-LGTH	5.000	
		0.400			

REFERENCE FILE

REFERENCE INFORMATION		
SREF	7.0686	SQ. IN.
LREF	3.0000	INCHES
BREF	3.0000	INCHES
XMRP	0.0000	INCHES
YMRP	0.0000	INCHES
ZMRP	0.0000	INCHES
SCALE	0.0000	NONE

BASIC LONGITUDINAL CHARACTERISTICS

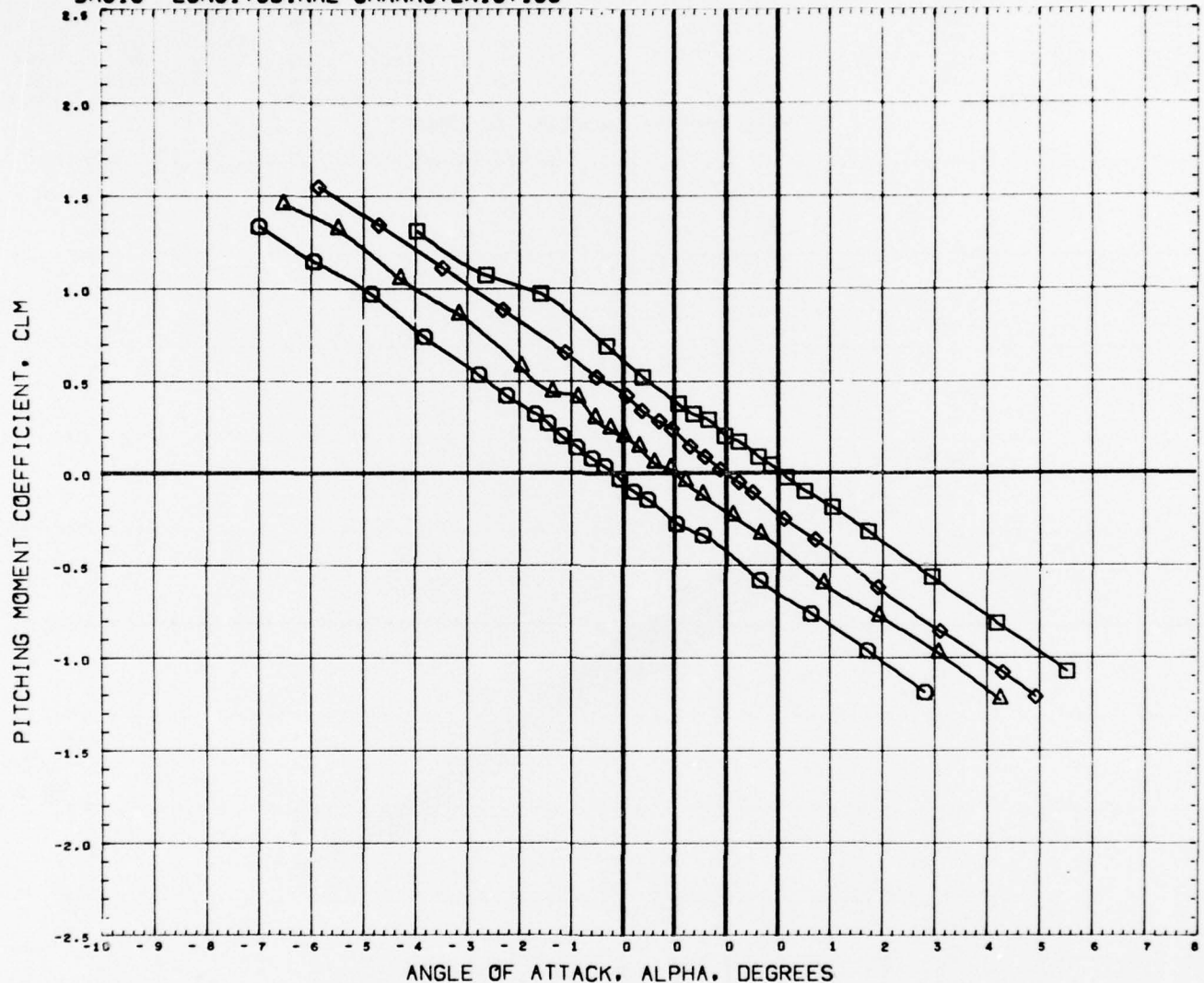

SYMBOL	MACH	PARAMETRIC VALUES				REFERENCE INFORMATION		
○	0.499	PHI	0.000	M-LGTH	2.250	SREF	7.0686	sq. IN.
△	0.801	LS-LGH	2.500	S-WDTH	0.400	LREF	3.0000	INCHES
◇	0.957	R-WDTH	1.000	C-LGTH	5.000	BREF	3.0000	INCHES
□	1.000	C-DIA	0.400			XMRP	0.0000	INCHES
						YMRP	0.0000	INCHES
						ZMRP	0.0000	INCHES
						SCALE	0.0000	NONE

REFERENCE FILE

BASIC LONGITUDINAL CHARACTERISTICS

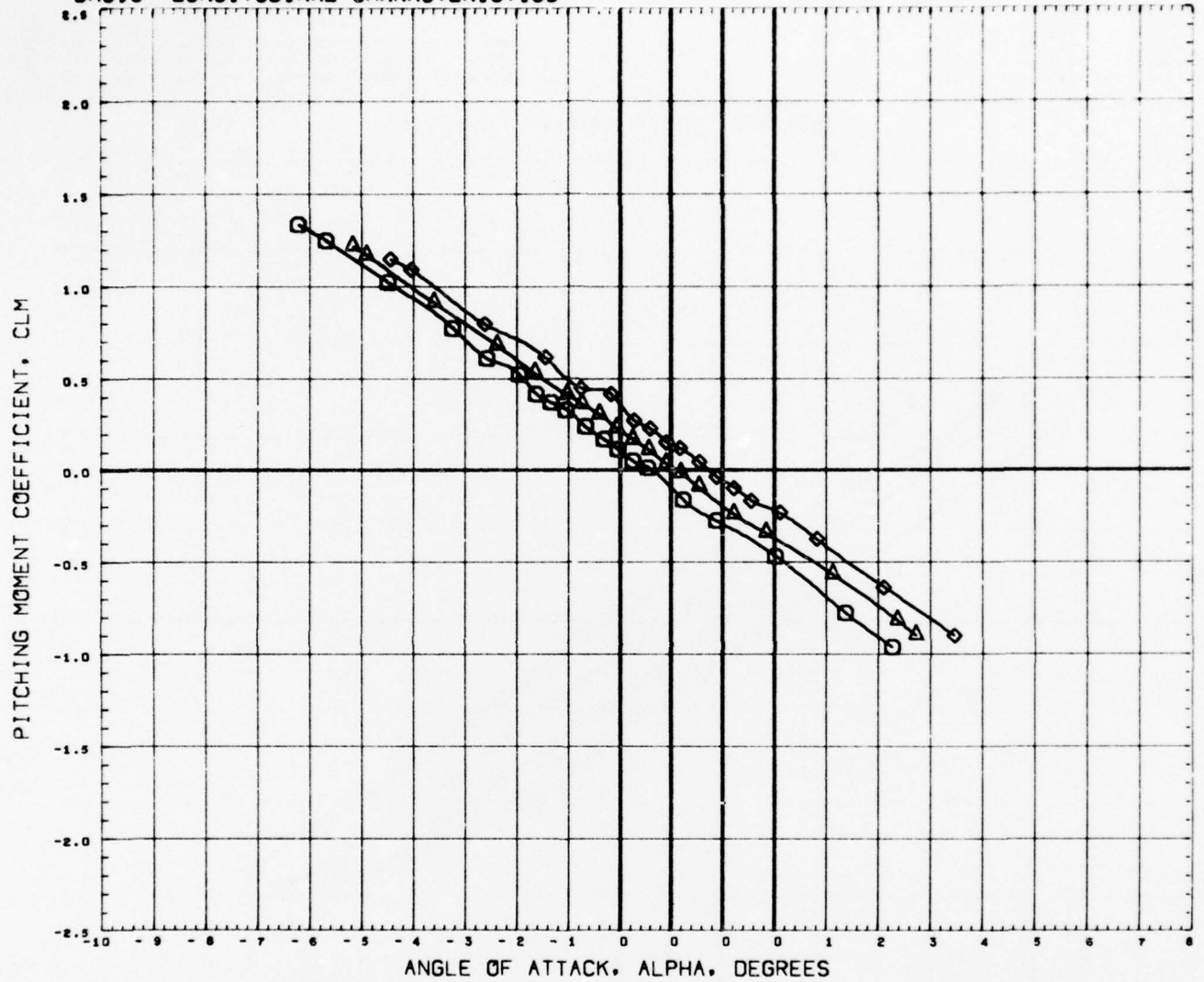

SYMBOL	MACH	PARAMETRIC VALUES				REFERENCE INFORMATION		
○	1.102	PHI	0.000	M-LGTH	2.250	SREF	7.0686	SQ. IN.
△	1.197	LS-LGH	2.500	S-WDTH	0.400	LREF	3.0000	INCHES
◇	1.298	R-WDTH	1.000	C-LGTH	5.000	BREF	3.0000	INCHES
		C-DIA	0.400			XWRP	0.0000	INCHES
						YWRP	0.0000	INCHES
						ZWRP	0.0000	INCHES
						SCALE	0.0000	NONE

REFERENCE FILE

BASIC LONGITUDINAL CHARACTERISTICS

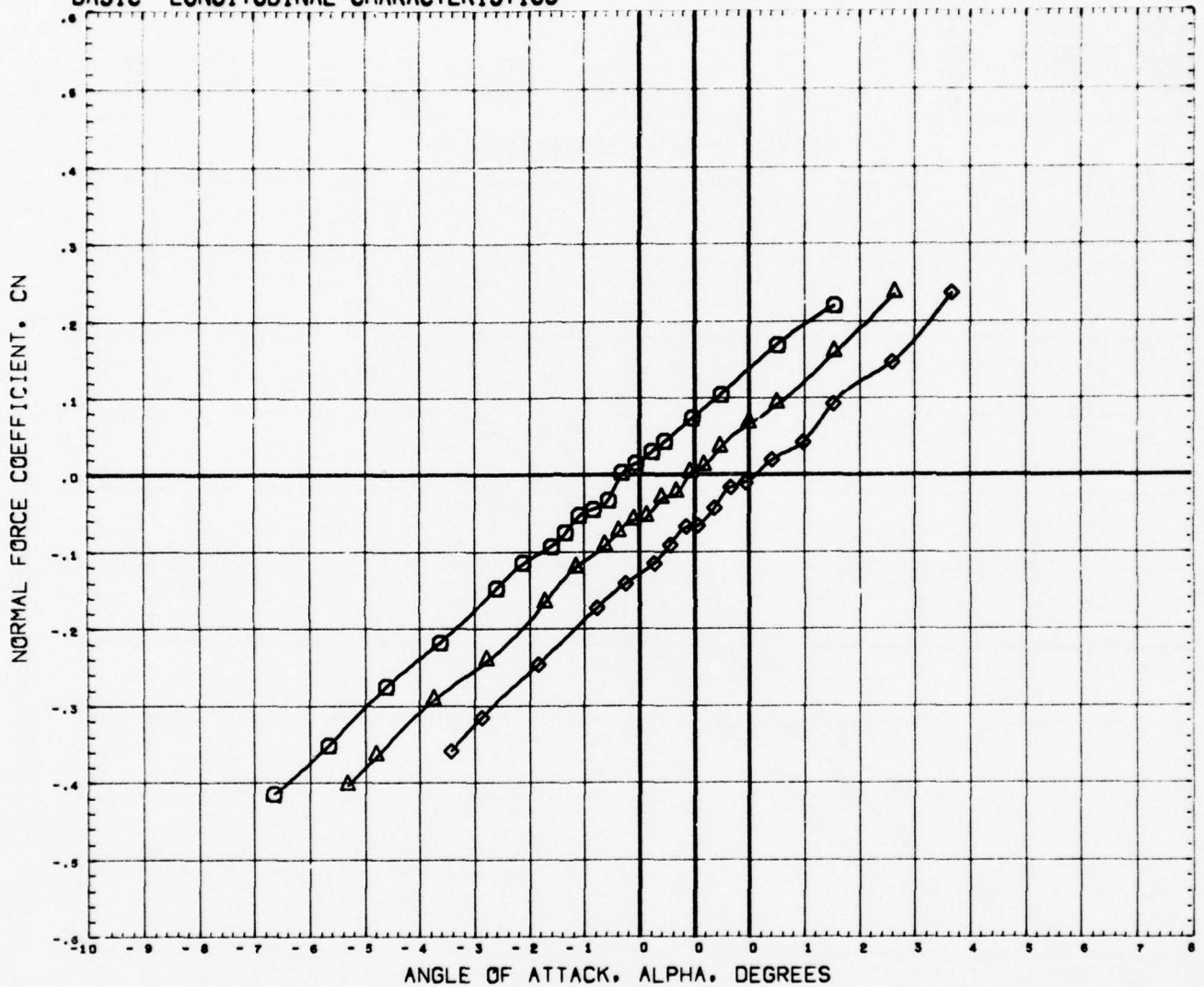

SYMBOL	MACH	PARAMETRIC VALUES				REFERENCE INFORMATION		
○	0.501	PHI	0.000	M-LGTH	2.250	SREF	7.0686	58. IN.
△	0.803	LS-LGM	4.000	S-WDTH	0.200	LREF	3.0000	INCHES
◇	0.946	R-WDTH	1.000	C-LGTH	9.000	BREF	3.0000	INCHES
		C-DIA	0.500			XNRP	0.0000	INCHES
						YNRP	0.0000	INCHES
						ZNRP	0.0000	INCHES
						SCALE	0.0000	NONE

REFERENCE FILE

BASIC LONGITUDINAL CHARACTERISTICS

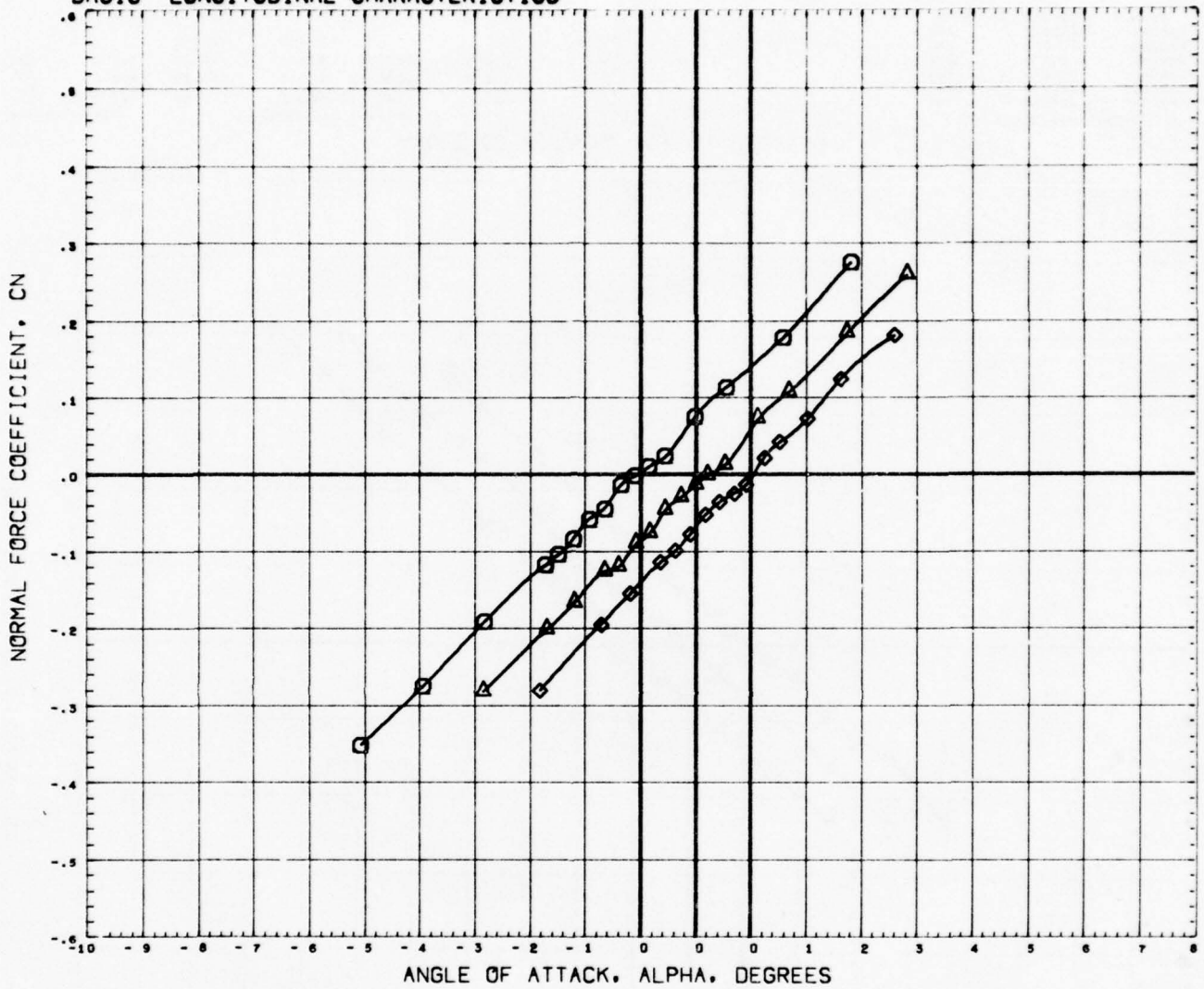

SYMBOL	MACH	PARAMETRIC VALUES			
○	1.101	PHI	0.000	M-LGTH	2.250
△	1.199	LS-LGH	4.000	S-WDTH	0.200
◇	1.298	R-WDTH	1.000	C-LGTH	5.000
		C-DIA	0.500		

REFERENCE INFORMATION		
SREF	7.0686	50. IN.
LREF	3.0000	INCHES
BREF	3.0000	INCHES
YNRP	0.0000	INCHES
ZNRP	0.0000	INCHES
SCALE	0.0000	NONE

REFERENCE FILE

BASIC LONGITUDINAL CHARACTERISTICS

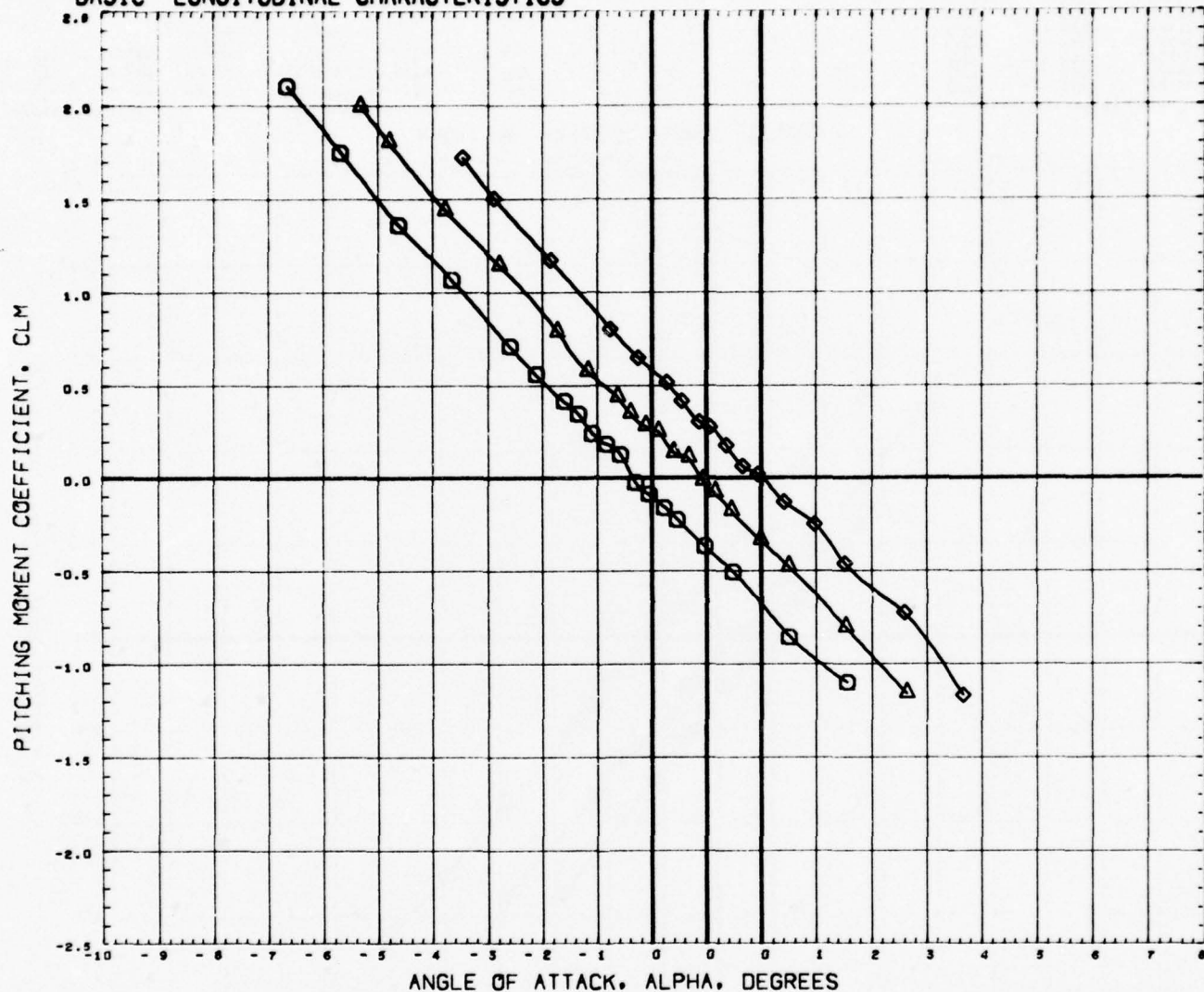

SYMBOL	MACH	PARAMETRIC VALUES				REFERENCE INFORMATION		
○	0.501	PHI	0.000	M-LGTH	2.250	SREF	7.0686	SQ. IN.
△	0.803	LS-LGH	4.003	S-WDTH	0.200	LREF	3.0000	INCHES
◇	0.946	R-WDTH	1.000	C-LGTH	5.000	BREF	3.0000	INCHES
		C-DIA	0.500			XMRP	0.0000	INCHES
						YMRP	0.0000	INCHES
						ZMRP	0.0000	INCHES
						SCALE	0.0000	NONE

REFERENCE FILE

BASIC LONGITUDINAL CHARACTERISTICS

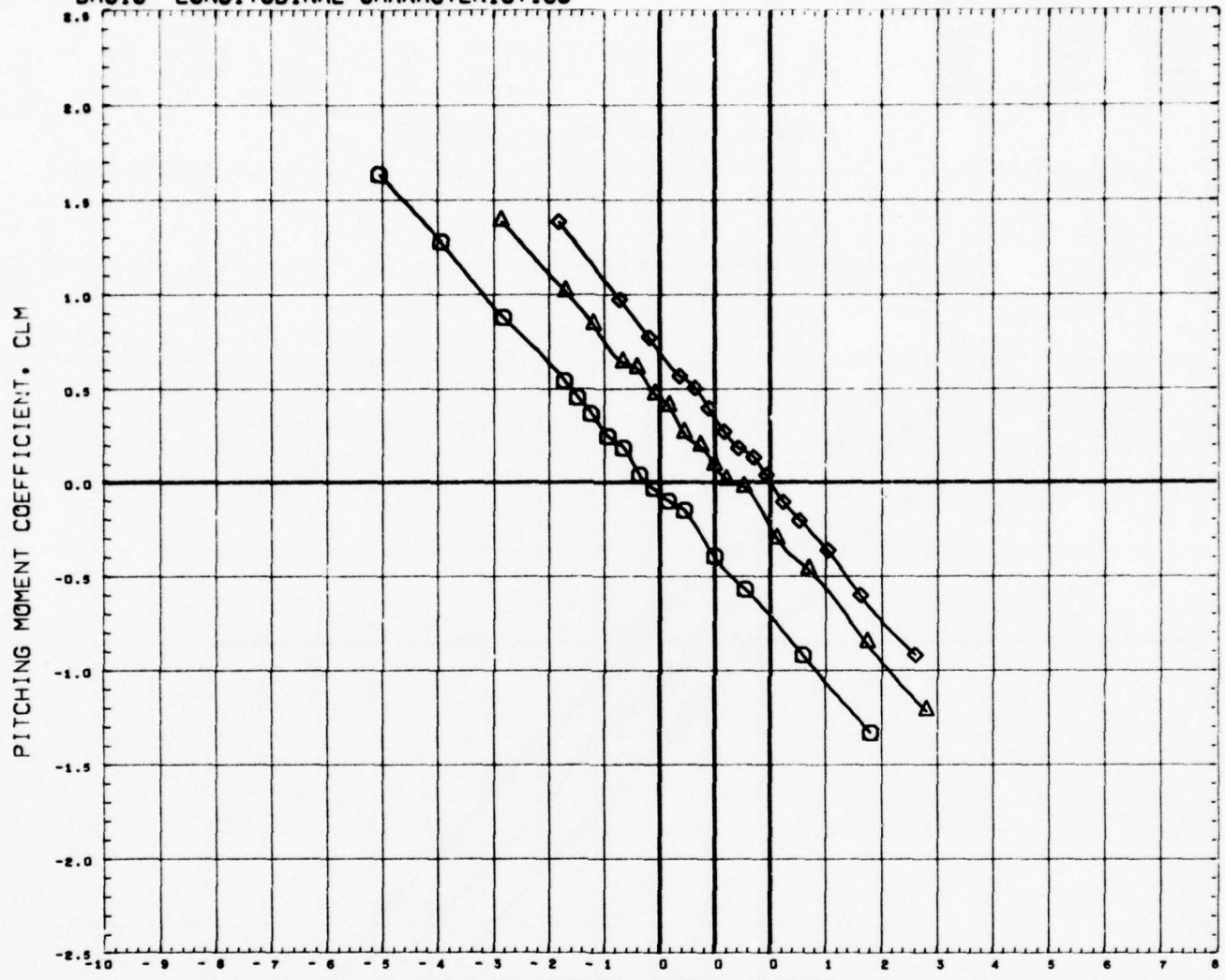

SYMBOL		MACH	PARAMETRIC VALUES				REFERENCE INFORMATION		
○		1.101	PHI	0.000	M-LGTH	2.250	SREF	7.0686	50. IN.
△		1.199	LS-LGH	4.000	S-WDTH	0.200	LREF	3.0000	INCHES
◇		1.298	R-WDTH	1.000	C-LGTH	5.000	BREF	3.0000	INCHES
			C-DIA	0.500			YMRP	0.0000	INCHES
							ZMRP	0.0000	INCHES
							SCALE	0.0000	NONE

REFERENCE FILE

BASIC LONGITUDINAL CHARACTERISTICS

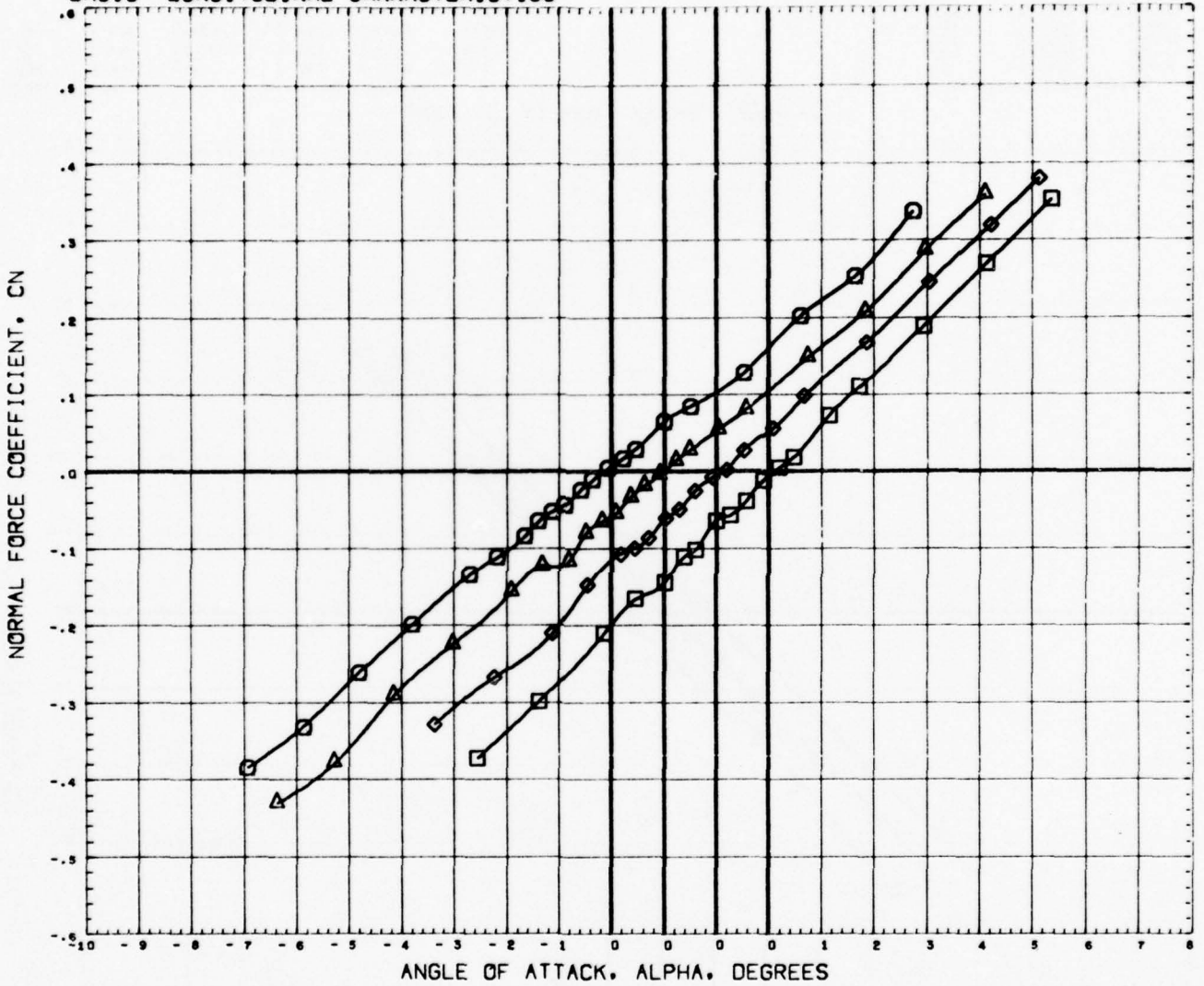

SYMBOL	MACH	PARAMETRIC VALUES				REFERENCE INFORMATION		
○	0.500	PHI	0.000	M-LGTH	1.500	SREF	7.0686	50. IN.
△	0.802	LS-LGH	3.250	S-WDTH	0.200	LREF	3.0000	INCHES
◇	0.950	R-WDTH	1.000	C-LGTH	5.000	BREF	3.0000	INCHES
□	1.003	C-DIA	0.500			XMRP	0.0000	INCHES
						YMRP	0.0000	INCHES
						ZMRP	0.0000	INCHES
						SCALE	0.0000	NONE

REFERENCE FILE

BASIC LONGITUDINAL CHARACTERISTICS

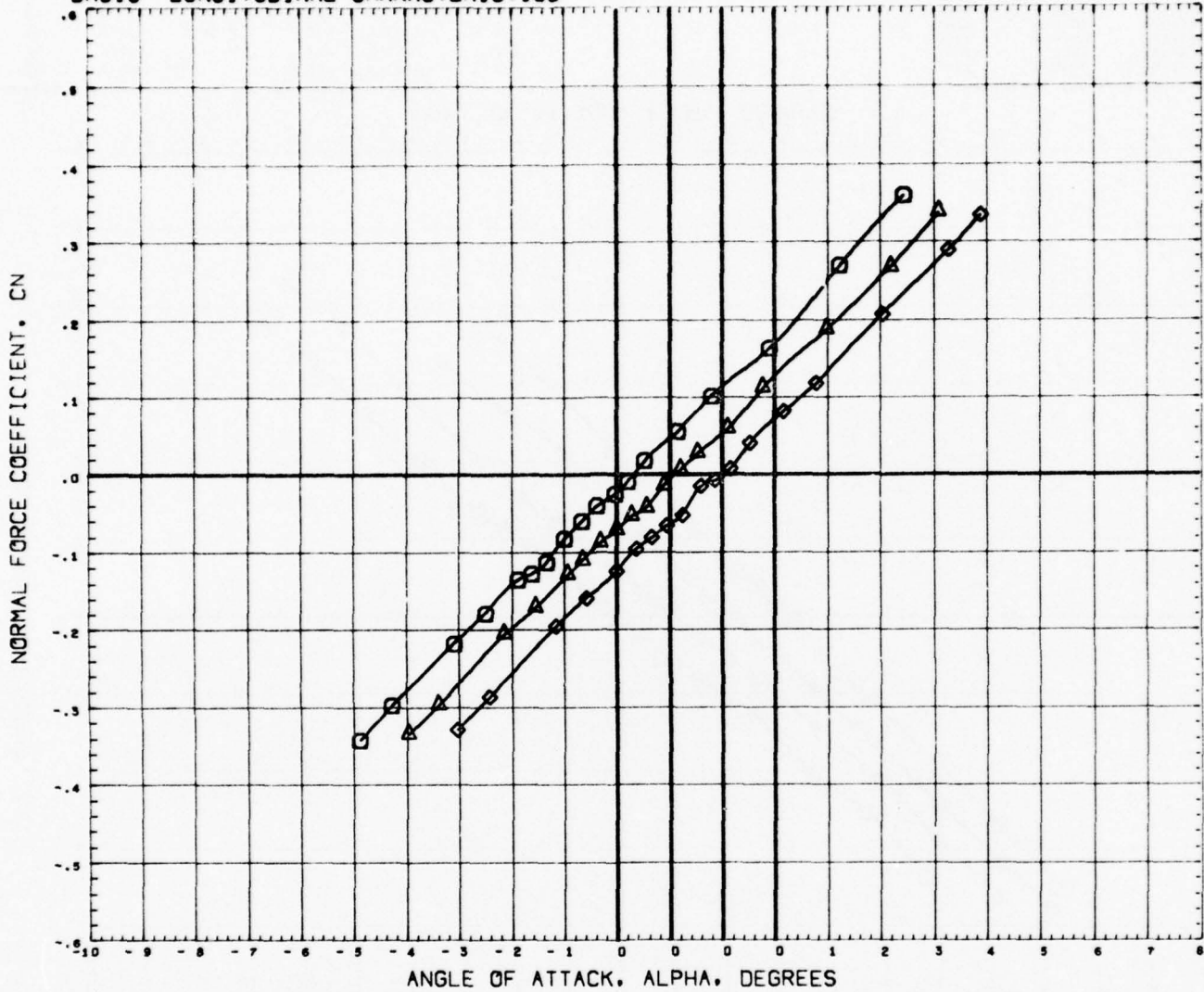

SYMBOL		MACH	PARAMETRIC VALUES				REFERENCE INFORMATION		
○		1.096	PHT	0.000	M-LGTH	1.500	SREF	7.0686	50. IN.
△		1.200	LS-LGH	3.250	S-WDTH	0.200	LREF	3.0000	INCHES
◇		1.300	R-WDTH	1.000	C-LGTH	5.000	BREF	3.0000	INCHES
			C-DIA	0.500			XWRP	0.0000	INCHES
							YWRP	0.0000	INCHES
							ZWRP	0.0000	INCHES
							SCALE	0.0000	NONE

REFERENCE FILE

BASIC LONGITUDINAL CHARACTERISTICS

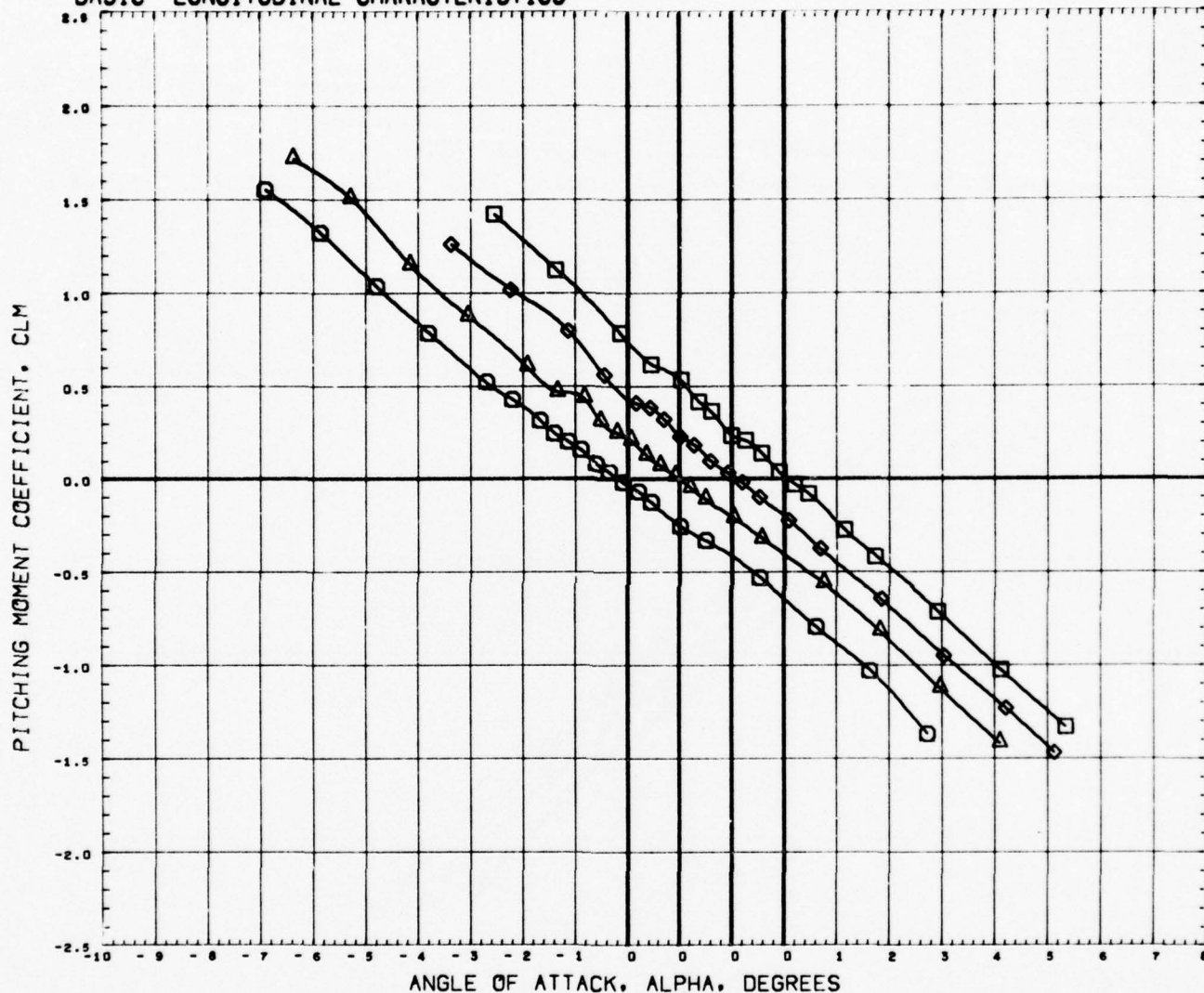

SYMBOL	MACH	PARAMETRIC VALUES				REFERENCE INFORMATION		
○	0.500	PHI	0.000	M-LGTH	1.500	SREF	7.0686	50. IN.
△	0.802	LS-LGH	3.250	S-WDTH	0.200	LREF	3.0000	INCHES
◇	0.950	R-WDTH	1.000	C-LGTH	5.000	BREF	3.0000	INCHES
□	1.003	C-DIA	0.500			XMRP	0.0000	INCHES
						YMRP	0.0000	INCHES
						ZMRP	0.0000	INCHES
						SCALE	0.0000	NONE

REFERENCE FILE

BASIC LONGITUDINAL CHARACTERISTICS

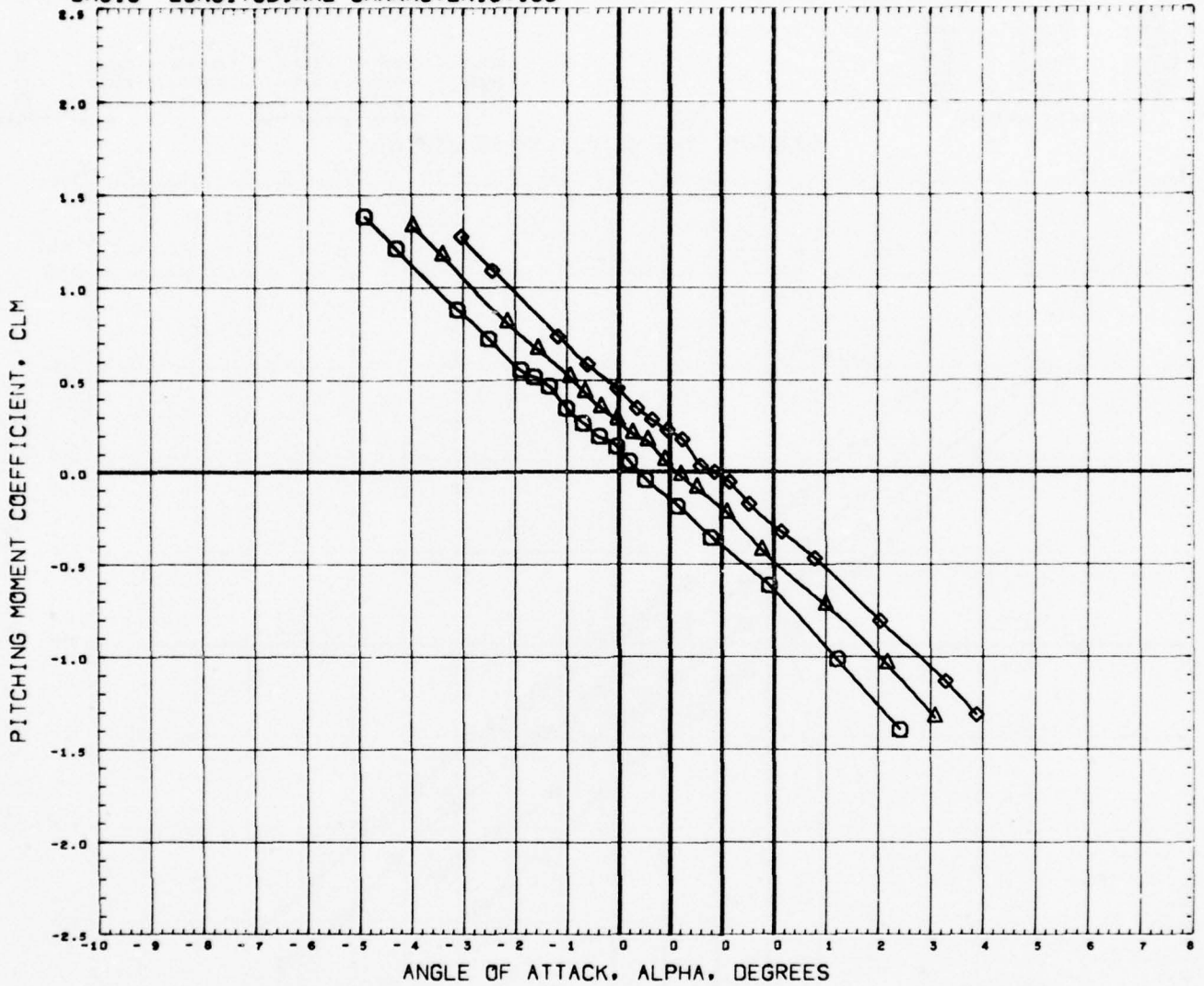

SYMBOL	MACH	PHI	PARAMETRIC VALUES		REFERENCE INFORMATION	
○	1.096	0.000	M-LGTH	1.500	SREF	7.0686 SQ. IN.
△	1.200	3.250	S-WIDTH	0.200	LREF	3.0000 INCHES
◇	1.300	1.000	C-LGTH	5.000	BREF	3.0000 INCHES
		0.500			XMRP	0.0000 INCHES
					YMRP	0.0000 INCHES
					ZMRP	0.0000 INCHES
					SCALE	0.0000 NONE

REFERENCE FILE

BASIC LONGITUDINAL CHARACTERISTICS

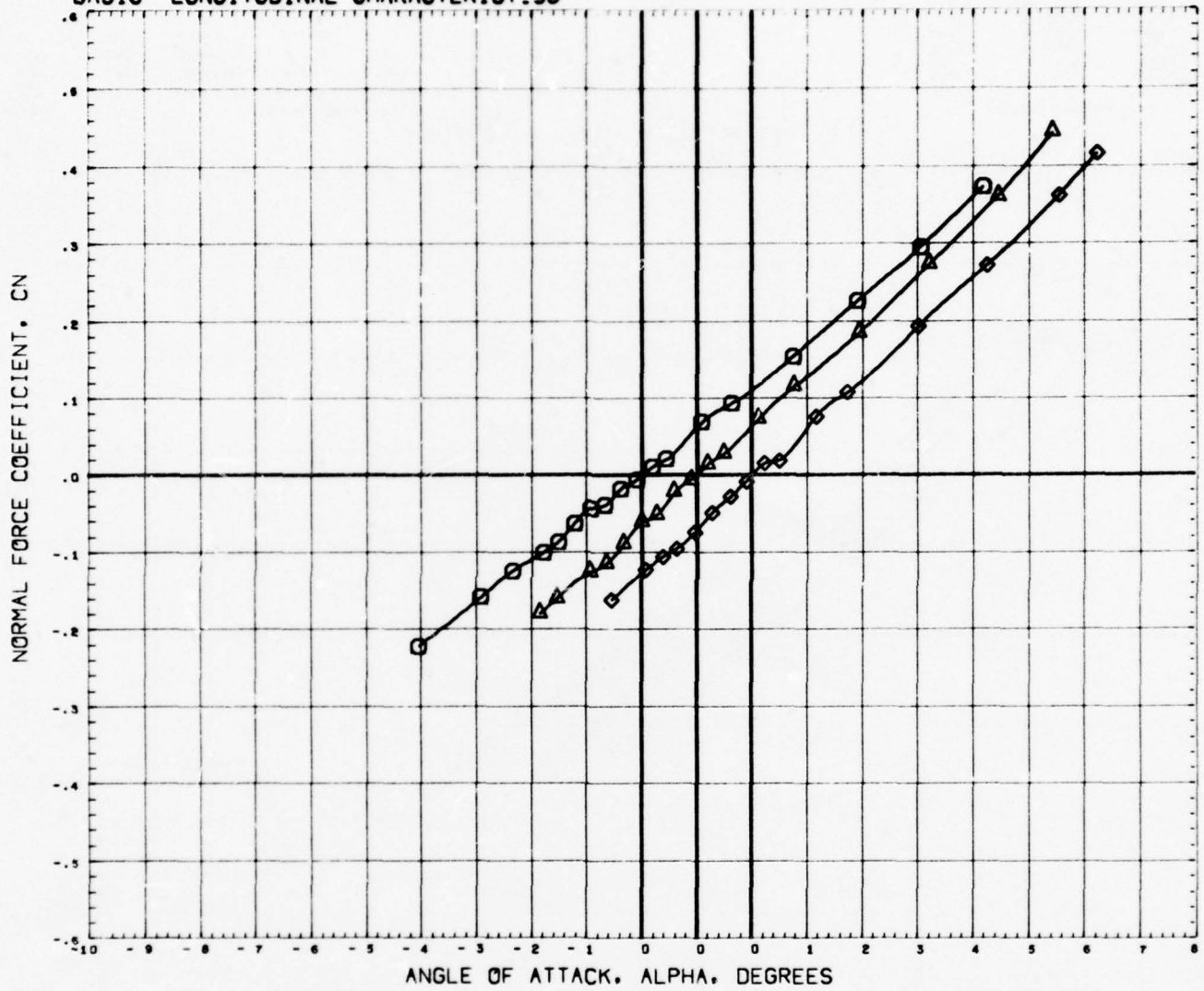

SYMBOL	MACH	PARAMETRIC VALUES				REFERENCE INFORMATION		
○	0.802	PHI	45.000	M-LGTH	1.500	SREF	7.0686	80. IN.
△	0.997	LS-LGH	3.250	S-WDTH	0.200	LREF	3.0000	INCHES
◇	1.200	R-WDTH	1.000	C-LGTH	5.000	BREF	3.0000	INCHES
		C-DIA	0.500			XMRP	0.0000	INCHES
						YMRP	0.0000	INCHES
						ZMRP	0.0000	INCHES
						SCALE	0.0000	NONE

REFERENCE FILE

BASIC LONGITUDINAL CHARACTERISTICS

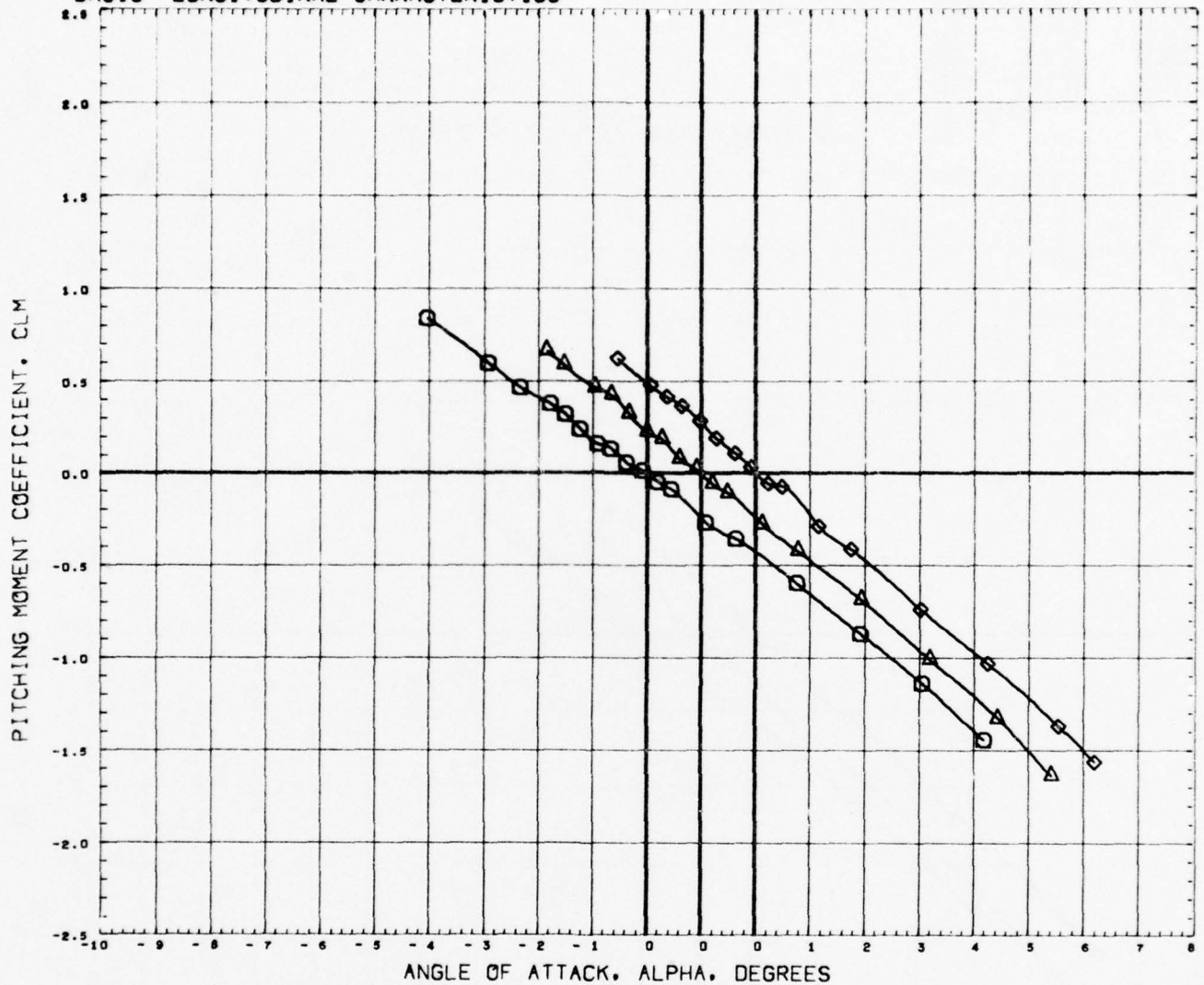

SYMBOL	MACH	PARAMETRIC VALUES				REFERENCE INFORMATION		
○	0.802	PHI	45.000	M-LGTH	1.500	SREF	7.0686	SQ. IN.
△	0.997	LS-LGH	3.250	S-WDTH	0.200	LREF	3.0000	INCHES
◇	1.200	R-WDTH	1.000	C-LGTH	5.000	BREF	3.0000	INCHES
		C-DIA	0.500			XMRP	0.0000	INCHES
						YMRP	0.0000	INCHES
						ZMRP	0.0000	INCHES
						SCALE	0.0000	NONE

REFERENCE FILE

BASIC LONGITUDINAL CHARACTERISTICS

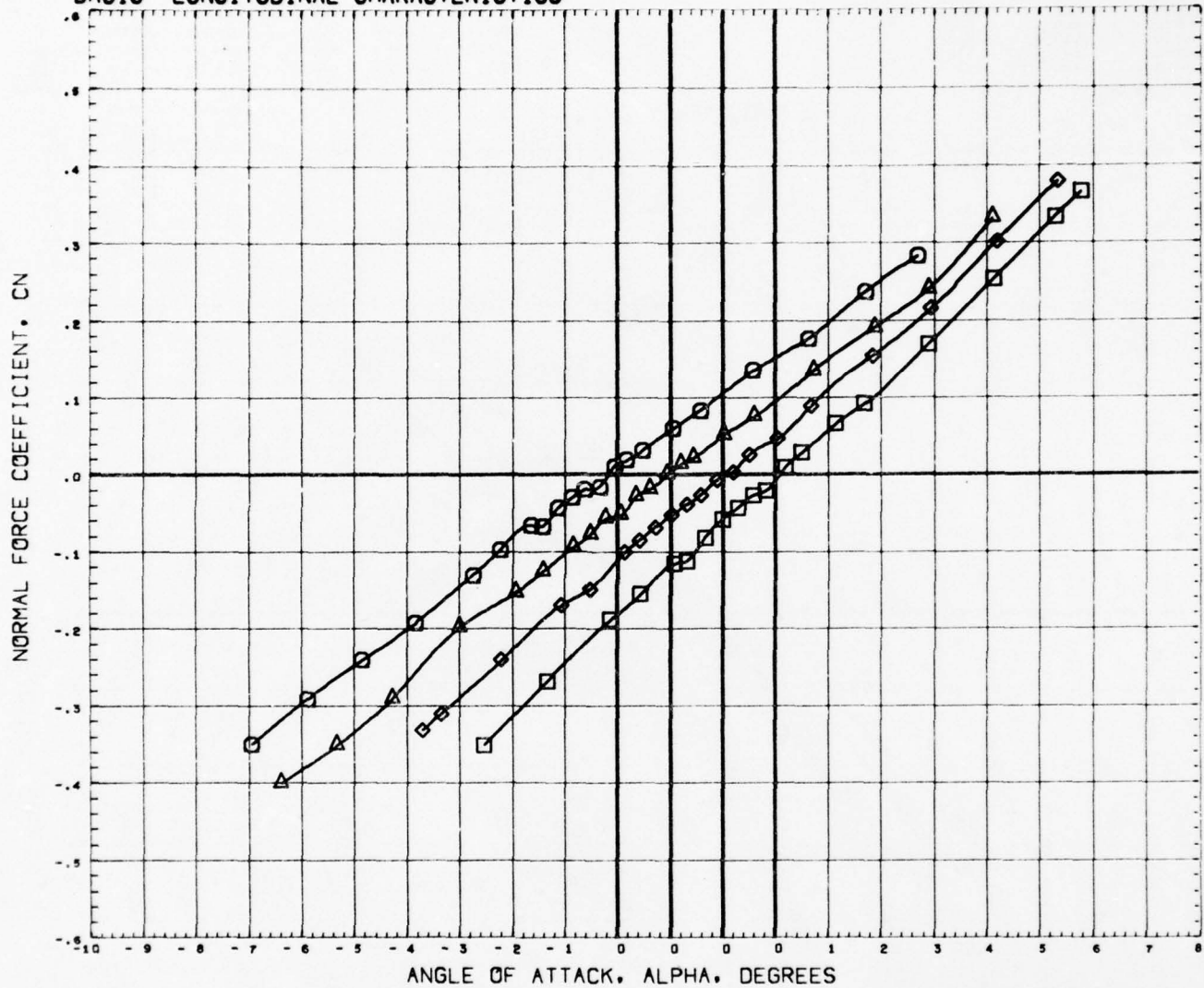

SYMBOL	MACH	PARAMETRIC VALUES				REFERENCE INFORMATION	
○	0.501	PHI	0.000	M-LGTH	1.500	SREF	7.0686 SQ. IN.
△	0.803	LS-LGH	3.250	S-WDTH	0.200	LREF	3.0000 INCHES
◇	0.947	R-WDTH	1.000	C-LGTH	5.000	BREF	3.0000 INCHES
□	0.998	C-DIA	0.670			XMRP	0.0000 INCHES
						YMRP	0.0000 INCHES
						ZMRP	0.0000 INCHES
						SCALE	0.0000 NONE

REFERENCE FILE

BASIC LONGITUDINAL CHARACTERISTICS

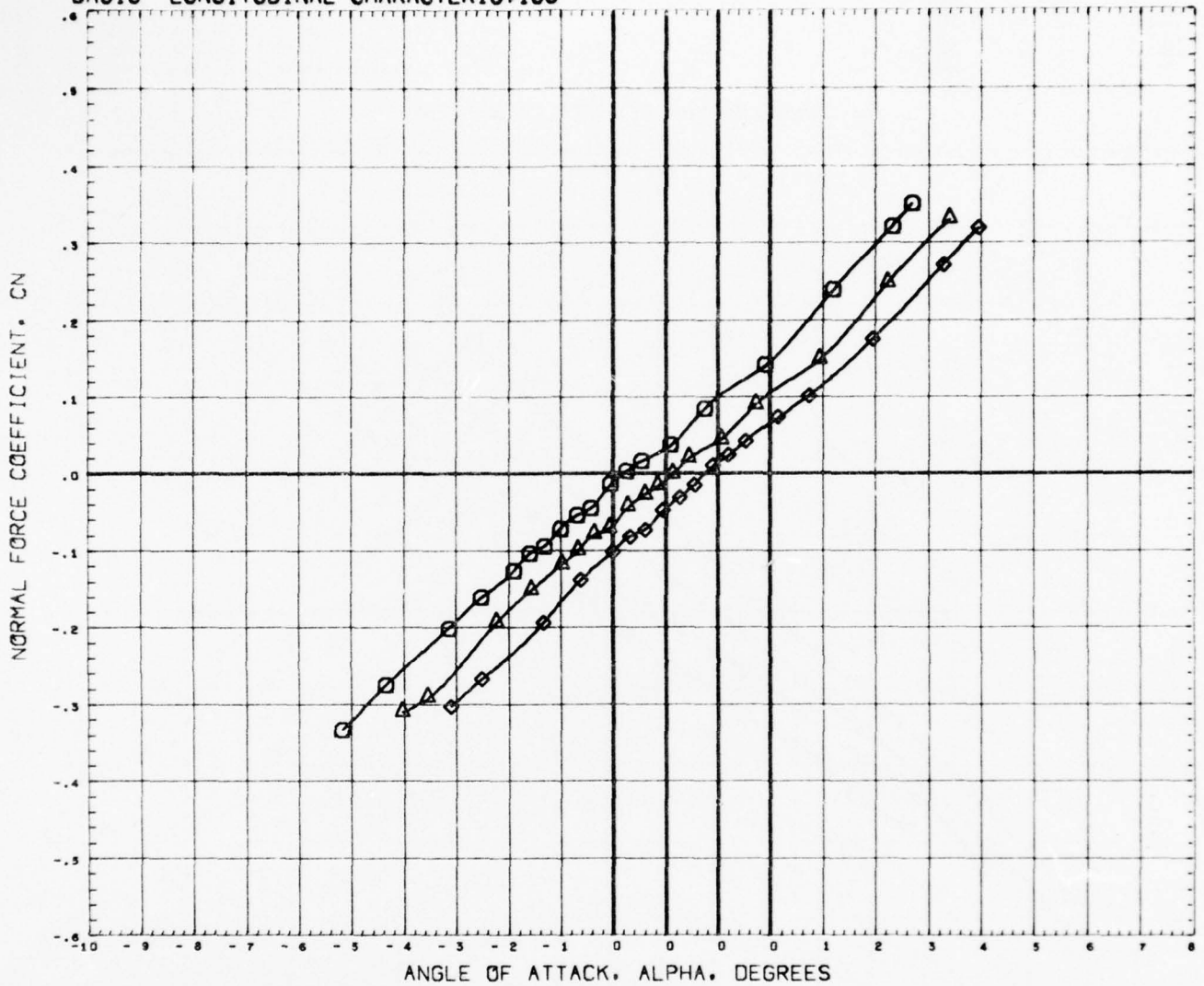

SYMBOL	MACH	PARAMETRIC VALUES				REFERENCE INFORMATION	
○	1.100	PHI	0.000	M-LGTH	1.500	SREF	7.0686 SQ. IN.
△	1.199	LS-LGH	3.250	S-WDTH	0.200	LREF	3.0000 INCHES
◇	1.299	R-WDTH	1.000	C-LGTH	5.000	BREF	3.0000 INCHES
		C-DIA	0.670			YNRP	0.0000 INCHES
						ZNRP	0.0000 INCHES
						SCALE	0.0000 NONE

REFERENCE FILE

BASIC LONGITUDINAL CHARACTERISTICS

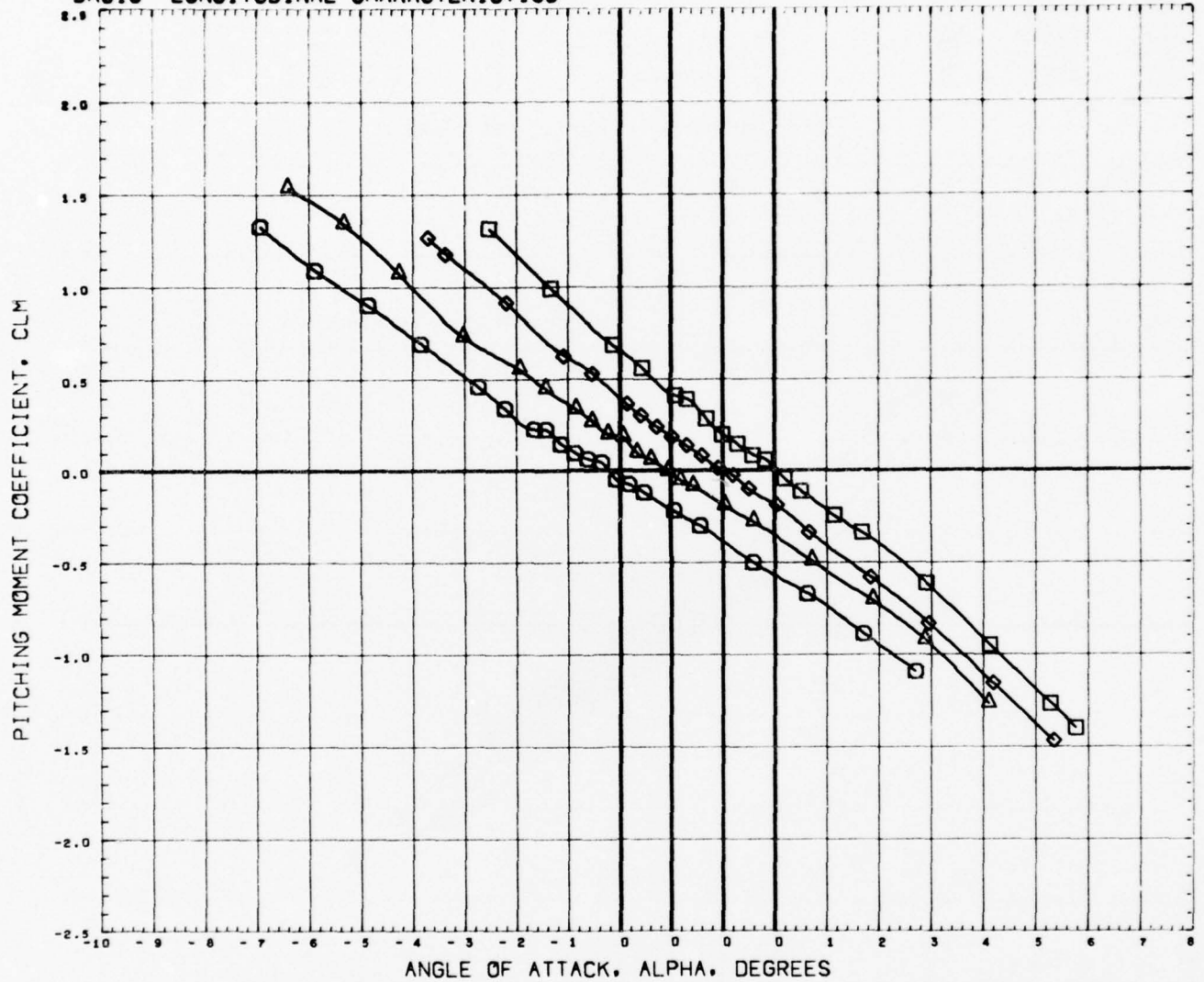

SYMBOL	MACH	PARAMETRIC VALUES				REFERENCE INFORMATION	
○	0.501	PHI	0.000	M-LGTH	1.500	SREF	7.0686 SQ. IN.
△	0.803	LS-LGH	3.250	S-WDTH	0.200	LREF	3.0000 INCHES
◇	0.947	R-WDTH	1.000	C-LGTH	5.000	BREF	3.0000 INCHES
□	0.998	C-DIA	0.670			XMRP	0.0000 INCHES
						YMRP	0.0000 INCHES
						ZMRP	0.0000 INCHES
						SCALE	0.0000 NONE

REFERENCE FILE

BASIC LONGITUDINAL CHARACTERISTICS

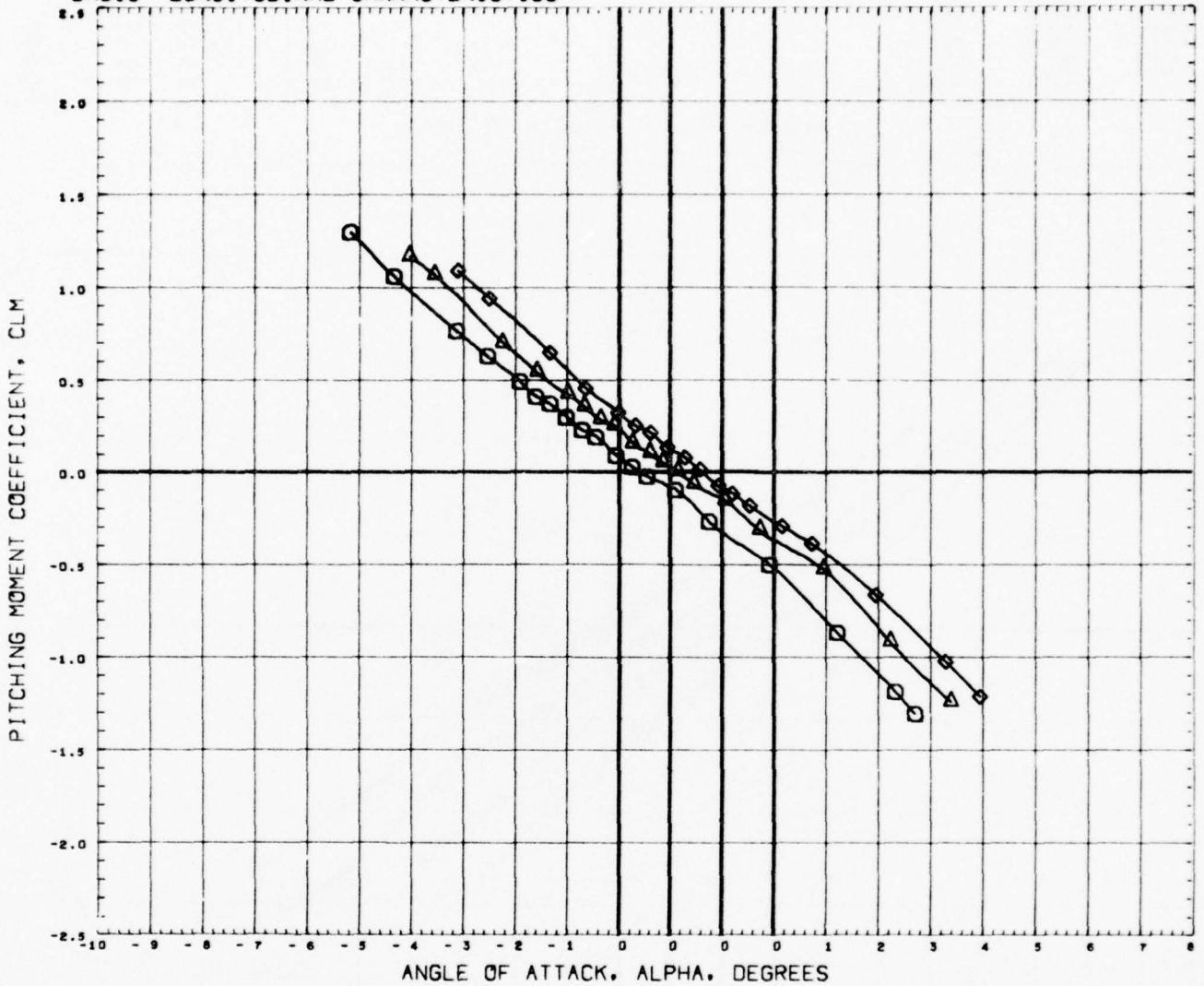

SYMBOL	MACH	PARAMETRIC VALUES				REFERENCE INFORMATION		
		PHI	M-LGTH	S-WDTH	C-LGTH	SREF	SQ. IN.	
○	1.100	0.000	1.500			7.0686	50. IN.	
△	1.199	LS-LGH	3.250	0.200		3.0000	INCHES	
◇	1.299	R-WDTH	1.000	5.000		3.0000	INCHES	
		C-DIA	0.670			XMRP	0.0000	INCHES
						YMRP	0.0000	INCHES
						ZMRP	0.0000	INCHES
						SCALE	0.0000	NONE

REFERENCE FILE

BASIC LONGITUDINAL CHARACTERISTICS

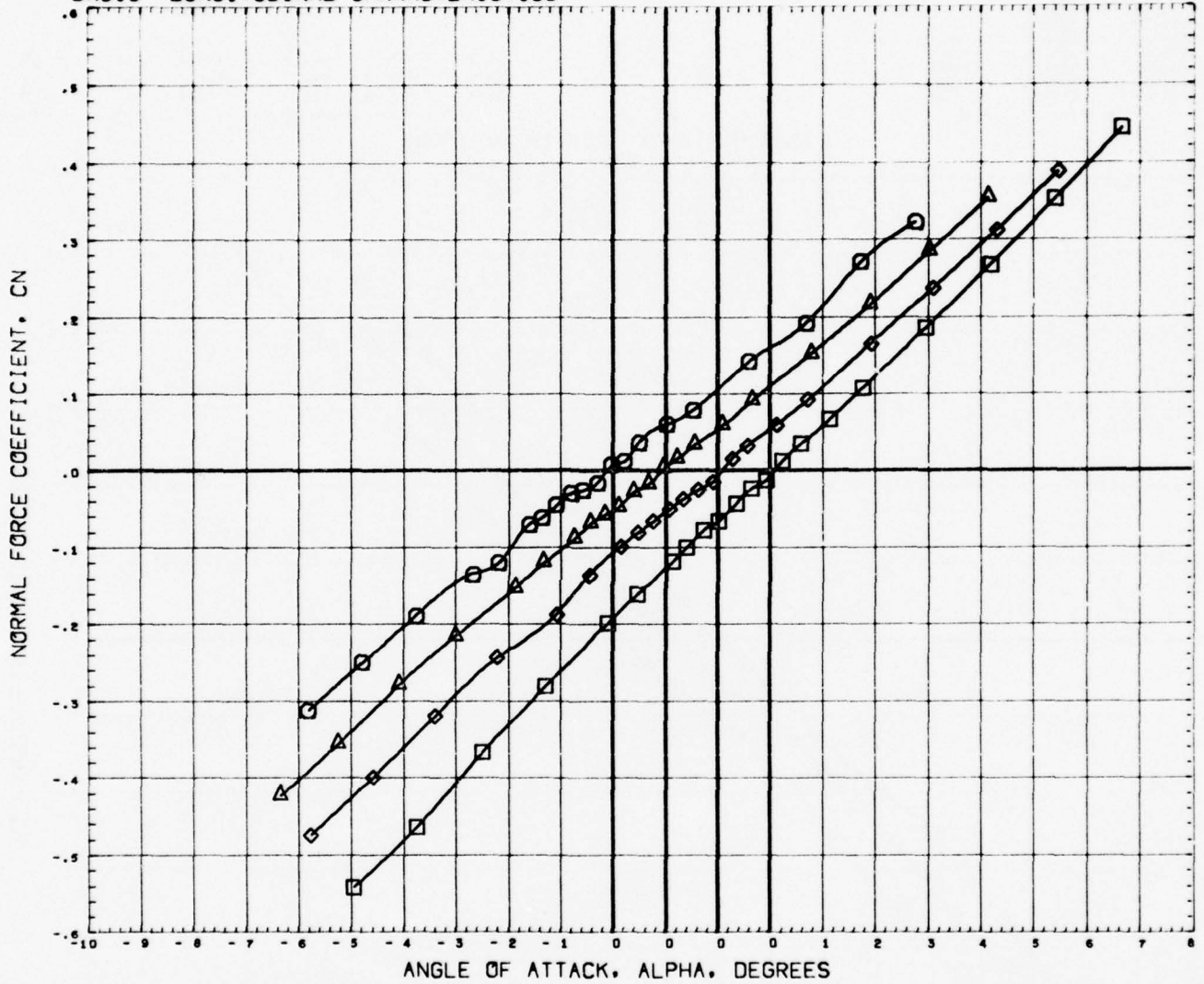

SYMBOL	MACH	PARAMETRIC VALUES				REFERENCE INFORMATION		
○	0.500	PHI	0.000	M-LGTH	1.500	SREF	7.0686	50. IN.
△	0.801	LS-LGH	3.250	S-WDTH	0.200	LREF	3.0000	INCHES
◇	0.950	R-WDTH	1.000	C-LGTH	6.500	BREF	3.0000	INCHES
□	1.002	C-DIA	0.500			XMRP	0.0000	INCHES
						YMRP	0.0000	INCHES
						ZMRP	0.0000	INCHES
						SCALE	0.0000	NONE

REFERENCE FILE

BASIC LONGITUDINAL CHARACTERISTICS

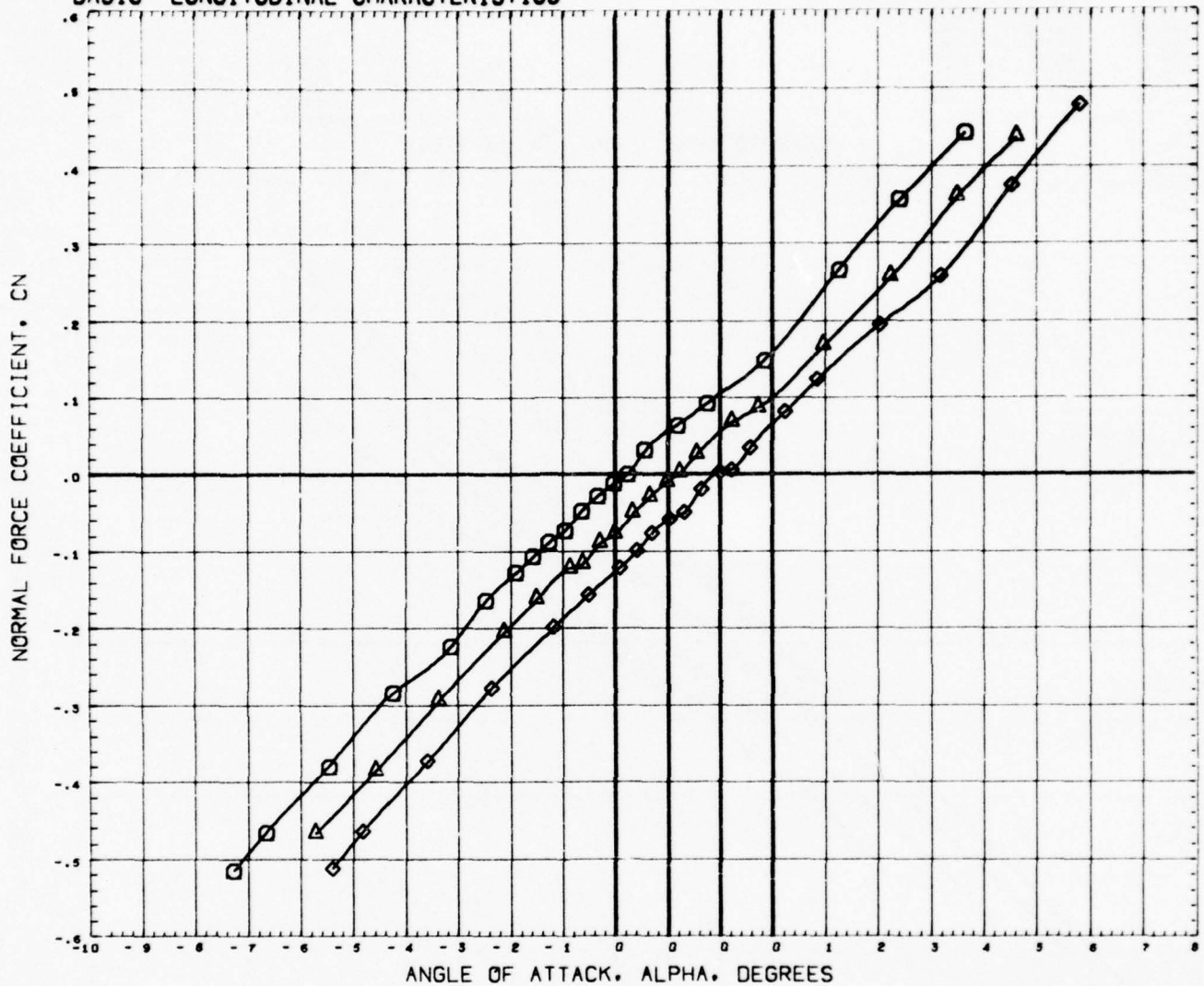

SYMBOL	MACH	PARAMETRIC VALUES				REFERENCE INFORMATION		
○	1.101	PHI	0.000	M-LGTH	1.500	SREF	7.0686	SQ. IN.
△	1.197	LS-LGH	3.250	S-WDTH	0.200	LREF	3.0000	INCHES
◇	1.297	R-WDTH	1.000	C-LGTH	6.500	BREF	3.0000	INCHES
		C-DIA	0.500			XMRP	0.0000	INCHES
						YMRP	0.0000	INCHES
						ZMRP	0.0000	INCHES
						SCALE	0.0000	NONE

REFERENCE FILE

BASIC LONGITUDINAL CHARACTERISTICS

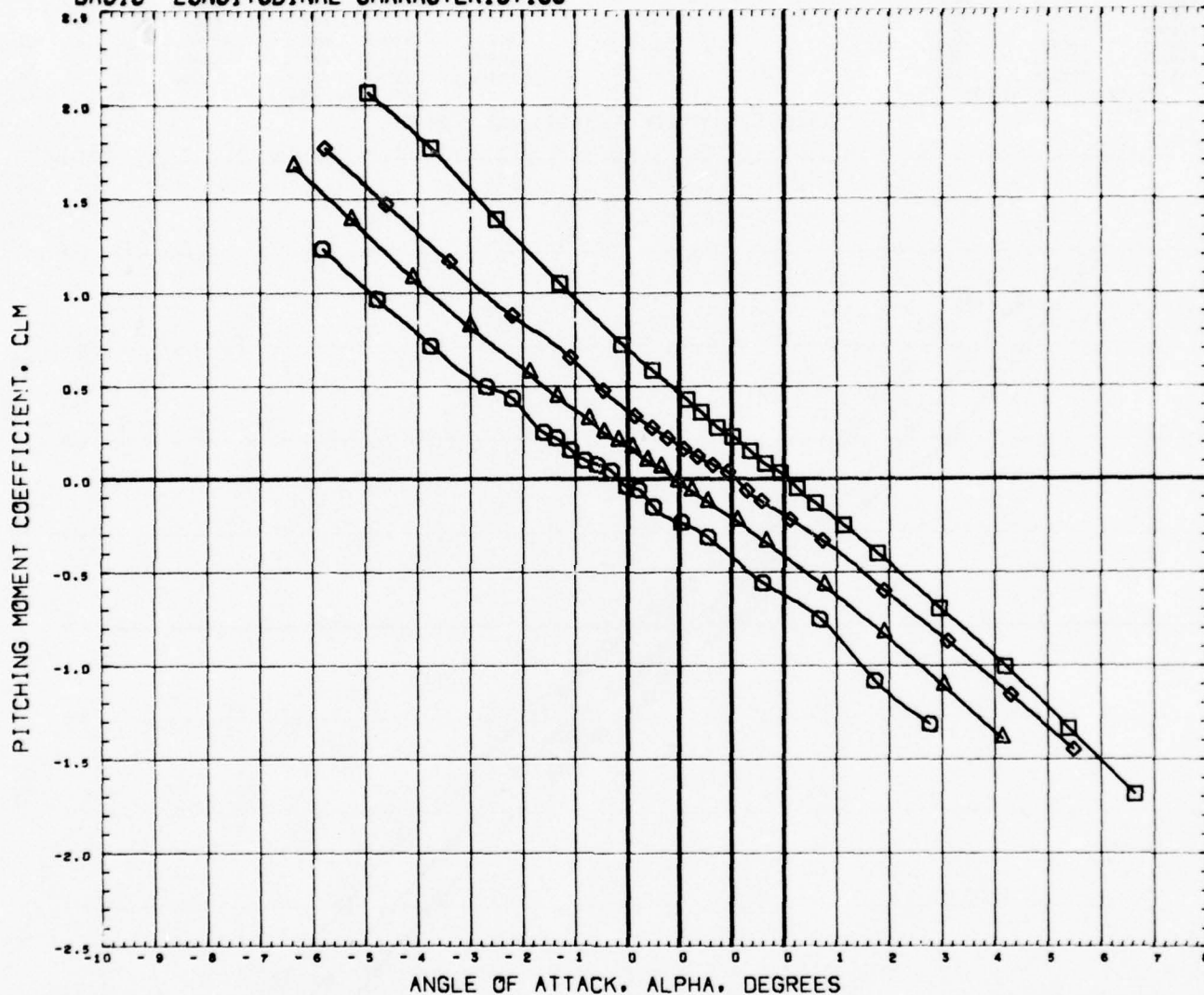

SYMBOL	MACH	PARAMETRIC VALUES				REFERENCE INFORMATION		
○	0.500	PHI	0.000	M-LGTH	1.500	SREF	7.0686	80. IN.
△	0.801	LS-LGM	3.250	S-WDTH	0.200	LREF	3.0000	INCHES
◇	0.950	R-WDTH	1.000	C-LGTH	6.500	BREF	3.0000	INCHES
□	1.002	C-DIA	0.500			XMRP	0.0000	INCHES
						YMRP	0.0000	INCHES
						ZMRP	0.0000	INCHES
						SCALE	0.0000	NONE

REFERENCE FILE

BASIC LONGITUDINAL CHARACTERISTICS

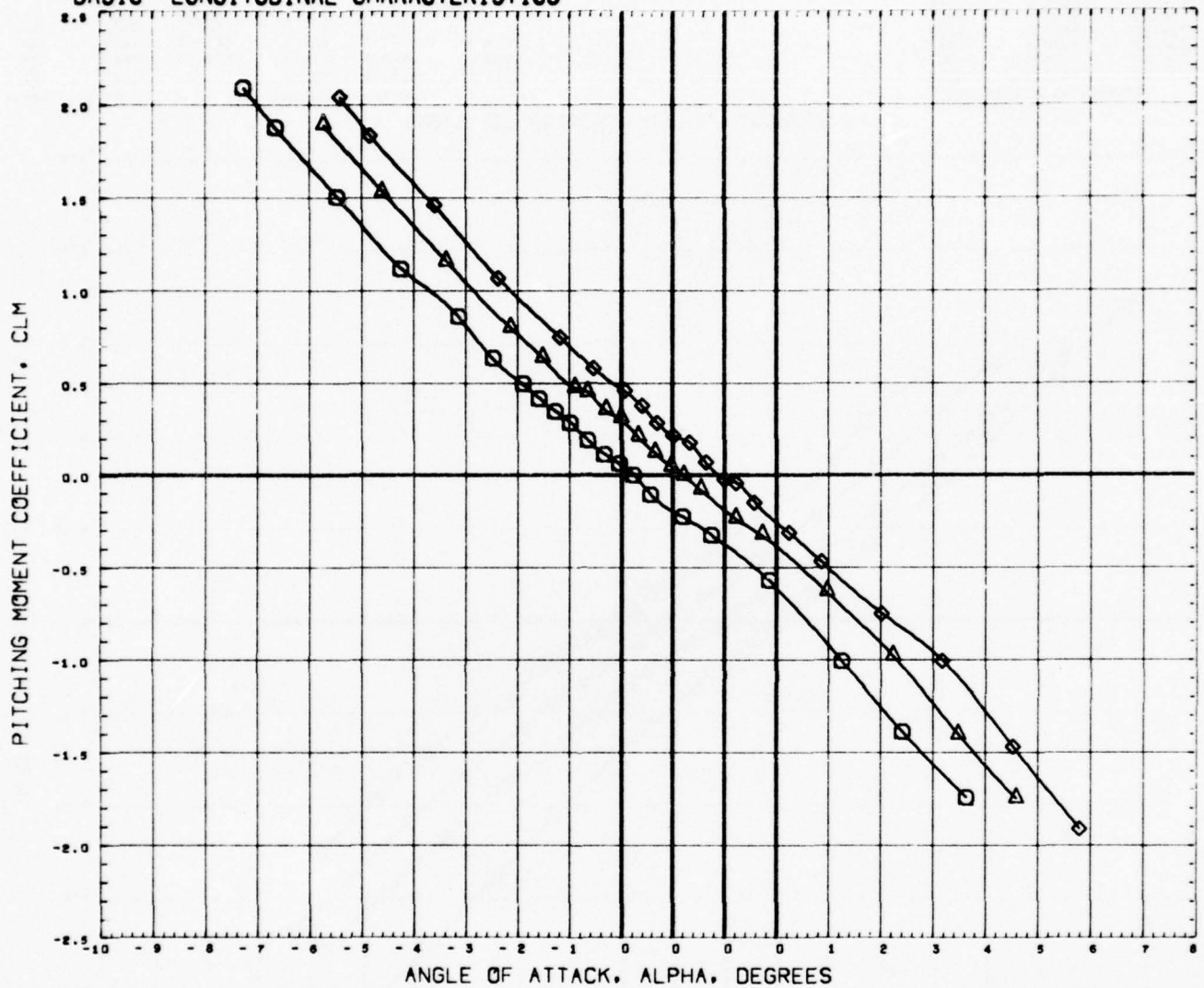

SYMBOL	MACH	PARAMETRIC VALUES				REFERENCE INFORMATION		
○	1.101	PHI	0.000	M-LGTH	1.500	SREF	7.0686	SQ. IN.
△	1.197	LS-LGH	3.250	S-WDTH	0.200	LREF	3.0000	INCHES
◇	1.297	R-WDTH	1.000	C-LGTH	6.500	BREF	3.0000	INCHES
		C-DIA	0.500			XMRP	0.0000	INCHES
						YMRP	0.0000	INCHES
						ZMRP	0.0000	INCHES
						SCALE	0.0000	NONE

REFERENCE FILE

BASIC LONGITUDINAL CHARACTERISTICS

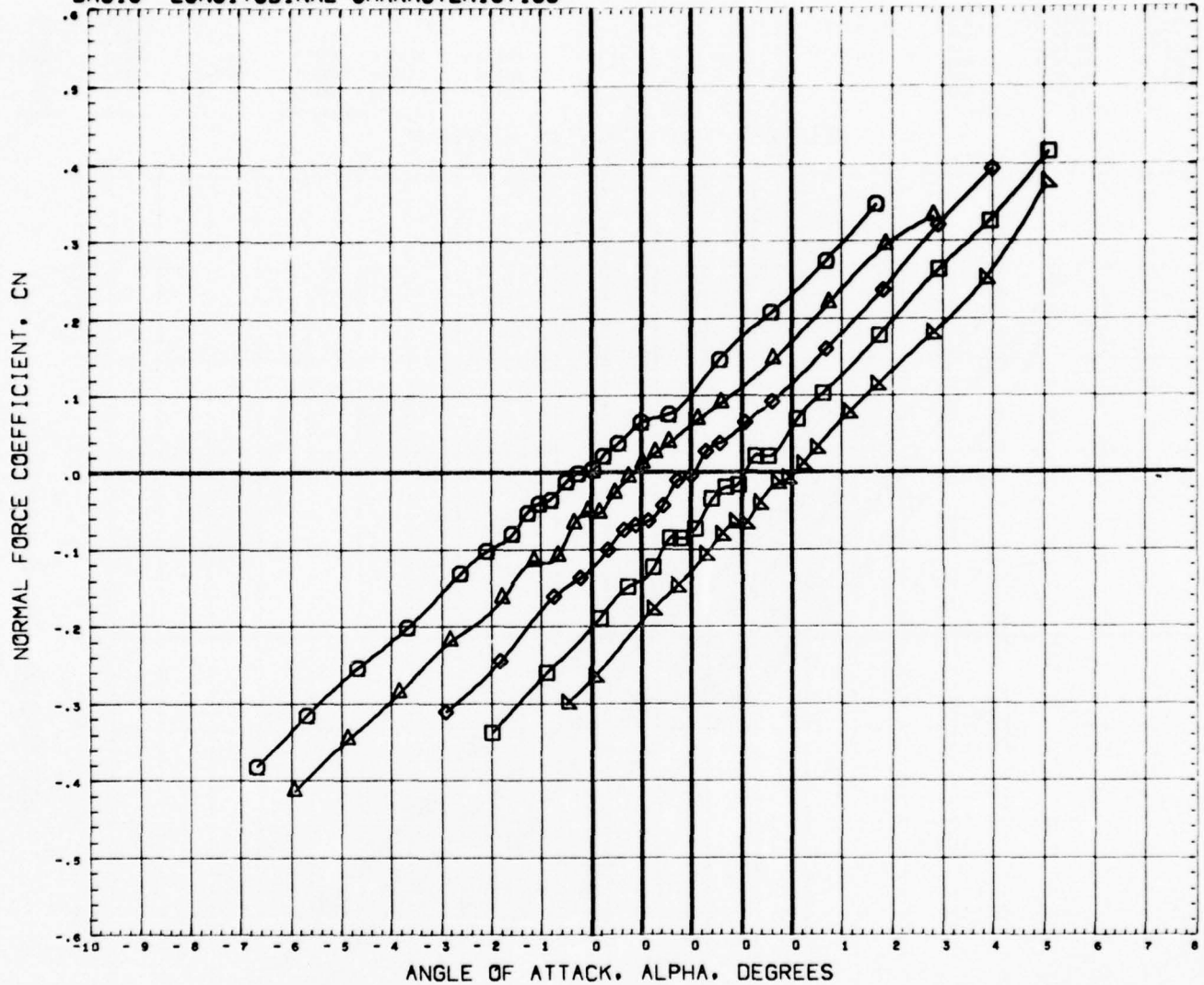

SYMBOL	MACH	PARAMETRIC VALUES				REFERENCE INFORMATION		
○	0.503	PHI	0.000	M-LGTH	2.250	SREF	7.0686	50. IN.
◇	0.604	LS-LGH	4.000	S-WDTH	0.200	LREF	3.0000	INCHES
△	0.958	R-WDTH	1.000	C-LGTH	6.500	BREF	3.0000	INCHES
□	0.999	C-DIA	0.500			XMRP	0.0000	INCHES
◇	1.099					YMRP	0.0000	INCHES
						ZMRP	0.0000	INCHES
						SCALE	0.0000	NONE

REFERENCE FILE

BASIC LONGITUDINAL CHARACTERISTICS

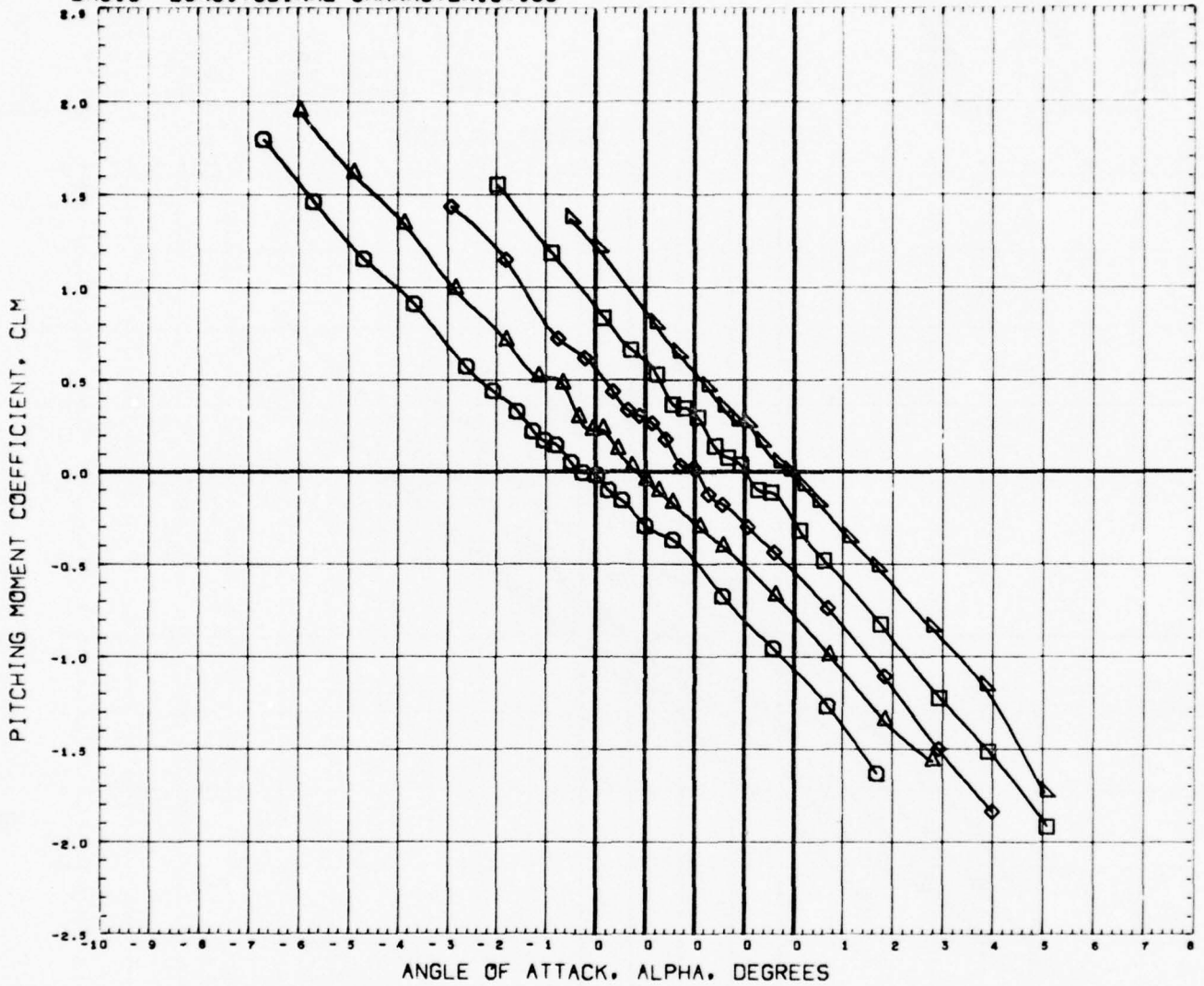

SYMBOL	MACH	PARAMETRIC VALUES				REFERENCE INFORMATION		
○	0.503	PHI	0.000	M-LGTH	2.250	SREF	7.0686	50. IN.
△	0.804	LS-LGH	4.000	S-WDTH	0.200	LREF	3.0000	INCHES
□	0.958	R-WDTH	1.000	C-LGTH	6.500	BREF	3.0000	INCHES
◇	0.999	C-DIA	0.500			XMRP	0.0000	INCHES
◻	1.099					YMRP	0.0000	INCHES
						ZMRP	0.0000	INCHES
						SCALE	0.0000	NONE

REFERENCE FILE

BASIC LONGITUDINAL CHARACTERISTICS

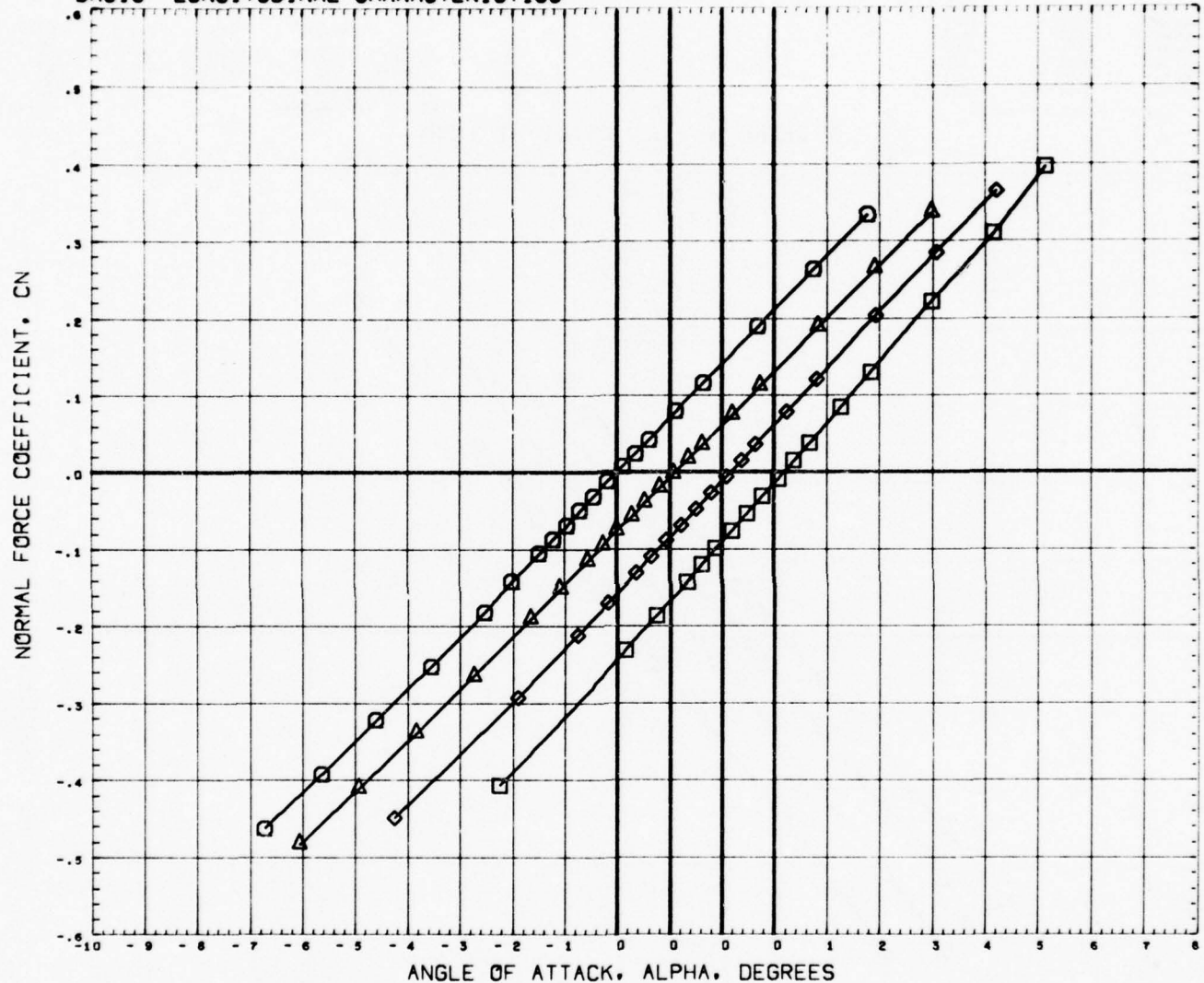

SYMBOL	MACH	PARAMETRIC VALUES				REFERENCE INFORMATION		
○	0.501	PHI	0.000	M-LGTH	1.500	SREF	7.0686	50. IN.
△	0.799	LS-LGH	3.250	S-WDTH	0.200	LREF	3.0000	INCHES
◇	0.948	R-WDTH	1.000	C-LGTH	5.000	BREF	3.0000	INCHES
□	0.999	C-DIA	0.400			XMRP	0.0000	INCHES
						YMRP	0.0000	INCHES
						ZMRP	0.0000	INCHES
						SCALE	0.0000	NONE

REFERENCE FILE

BASIC LONGITUDINAL CHARACTERISTICS

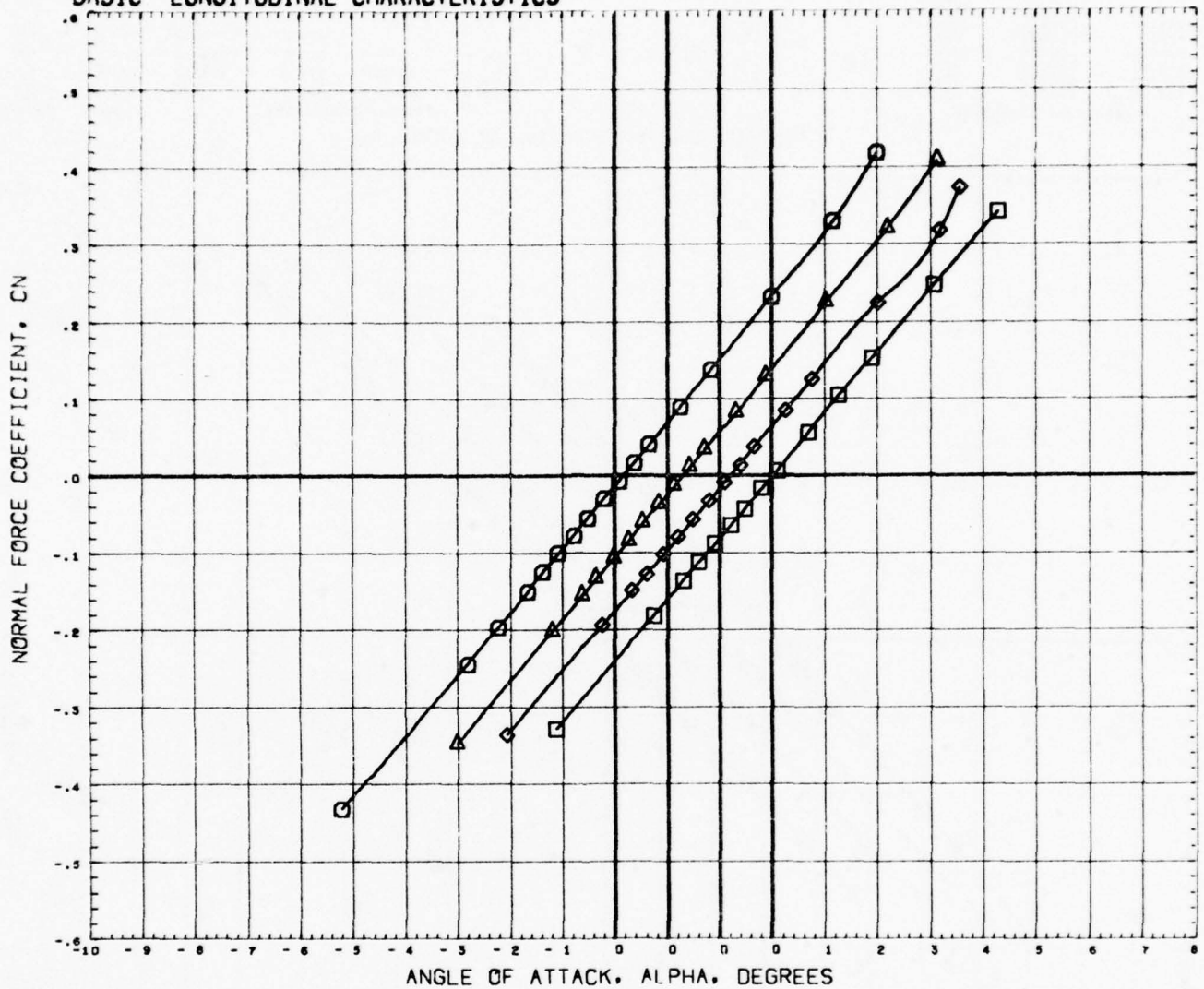

SYMBOL	MACH	PARAMETRIC VALUES				REFERENCE INFORMATION		
○	1.049	PHI	0.000	M-LGTH	1.500	SREF	7.0686	50. IN.
△	1.098	LS-LGH	3.250	S-WDTH	0.200	LREF	3.0000	INCHES
◇	1.197	R-WDTH	1.000	C-LGTH	5.000	BREF	3.0000	INCHES
□	1.296	C-DIA	0.400			YMRP	0.0000	INCHES
						ZMRP	0.0000	INCHES
						SCALE	0.0000	NONE

REFERENCE FILE

BASIC LONGITUDINAL CHARACTERISTICS

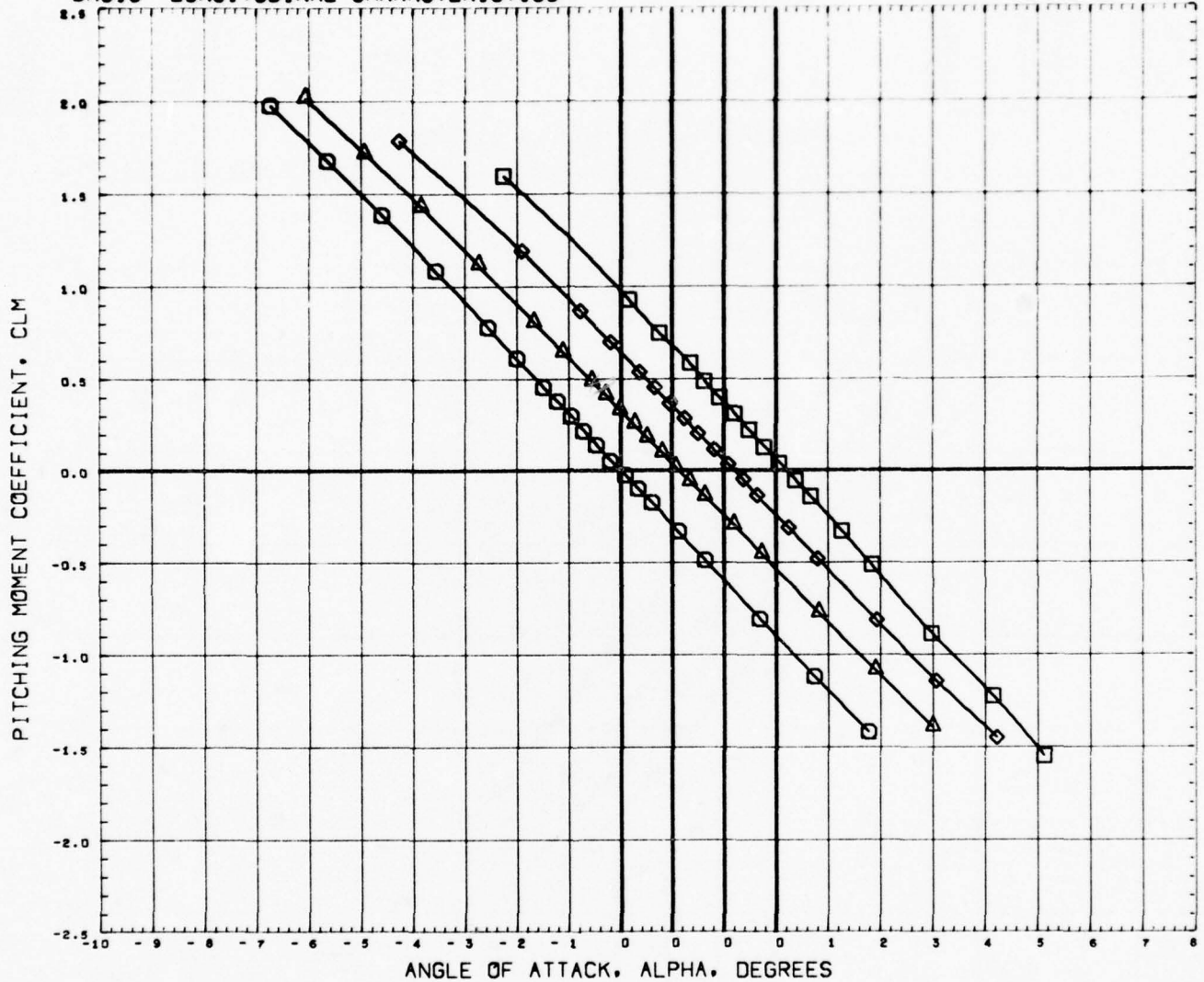

SYMBOL	MACH	PARAMETRIC VALUES				REFERENCE INFORMATION		
		PHI	H-LGTH	S-WIDTH	C-LGTH	SREF	INCHES	SQ. IN.
○	0.501	0.000	1.500	0.200	5.000	7.0686	3.0000	9.0721
△	0.799	3.250	0.200	5.000	3.0000	3.0000	9.0000	
◇	0.948	1.000	5.000	0.000	0.0000	0.0000	0.0000	
□	0.999	0.400	0.000	0.000	0.0000	0.0000	0.0000	

REFERENCE FILE

BASIC LONGITUDINAL CHARACTERISTICS

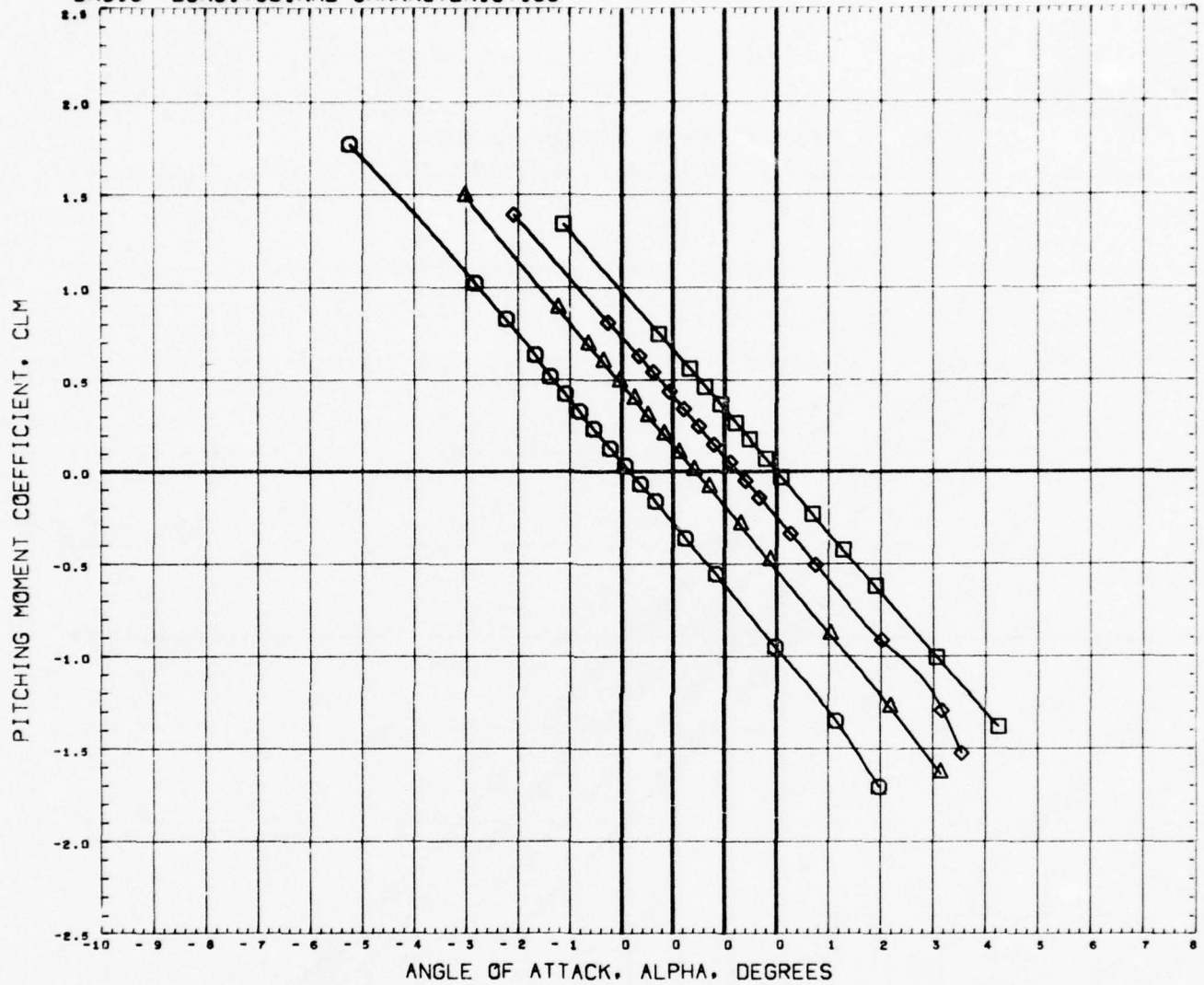

SYMBOL	MACH	PARAMETRIC VALUES			
○	1.049	PHI	0.000	M-LGTH	1.500
△	1.098	LS-LGH	3.250	S-WDTH	0.200
◇	1.197	R-WDTH	1.000	C-LGTH	5.000
□	1.296	C-DIA	0.400		

REFERENCE INFORMATION		
SREF	7.0686	SQ. IN.
LREF	3.0000	INCHES
BREF	3.0000	INCHES
XMRP	0.0000	INCHES
YMRP	0.0000	INCHES
ZMRP	0.0000	INCHES
SCALE	0.0000	NONE

REFERENCE FILE

BASIC LONGITUDINAL CHARACTERISTICS

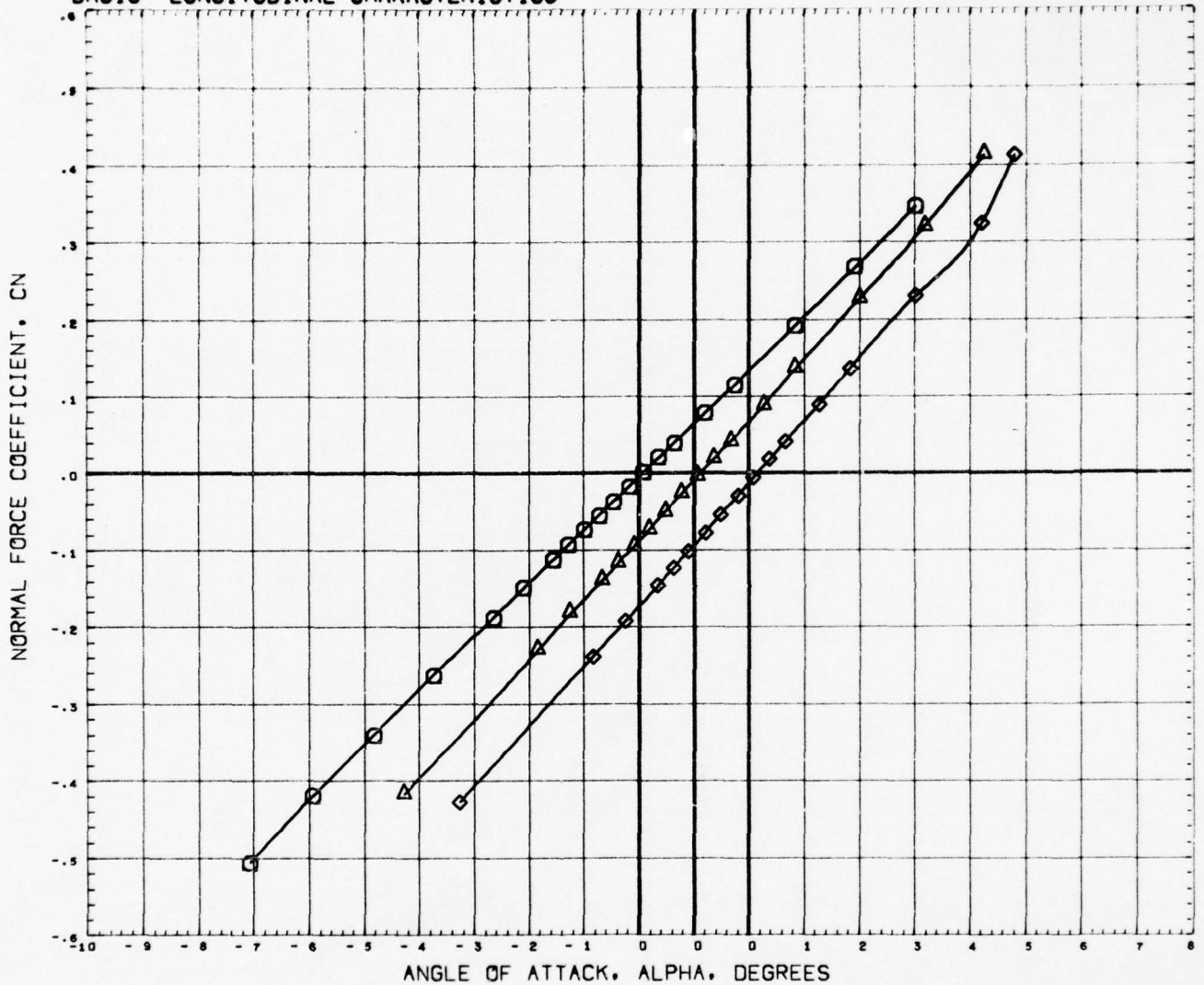

SYMBOL	MACH	PARAMETRIC VALUES				REFERENCE INFORMATION		
○	0.800	PHI	22.500	M-LGTH	1.500	SREF	7.0686	50. IN.
△	1.001	LS-LGH	3.250	S-WDTH	0.200	LREF	3.0000	INCHES
◇	1.137	R-WDTH	1.000	C-LGTH	5.000	BREF	3.0000	INCHES
		C-DIA	0.400			XNRP	0.0000	INCHES
						YNRP	0.0000	INCHES
						ZNRP	0.0000	INCHES
						SCALE	0.0000	NONE

REFERENCE FILE

BASIC LONGITUDINAL CHARACTERISTICS

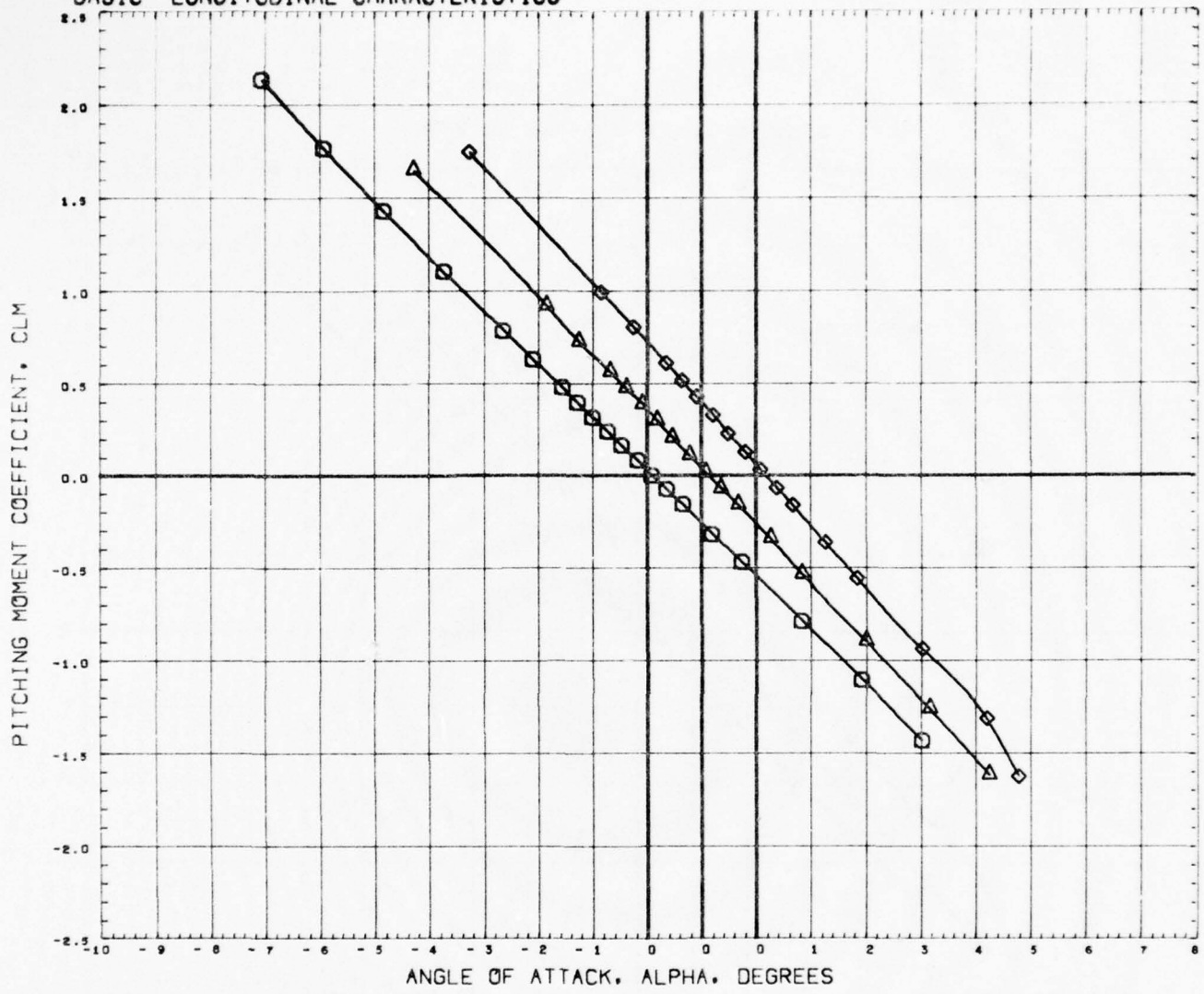

SYMBOL	MACH	PARAMETRIC VALUES				REFERENCE INFORMATION		
○	0.800	PHI	22.500	M-LGTH	1.500	SREF	7.0686	SQ. IN.
△	1.001	LS-LGH	3.250	S-WDTH	0.200	LREF	3.0000	INCHES
◇	1.197	R-WDTH	1.000	C-LGTH	5.000	BREF	3.0000	INCHES
		C-DIA	0.400			YMRP	0.0000	INCHES
						ZMRP	0.0000	INCHES
						SCALE	0.0000	NONE

REFERENCE FILE

BASIC LONGITUDINAL CHARACTERISTICS

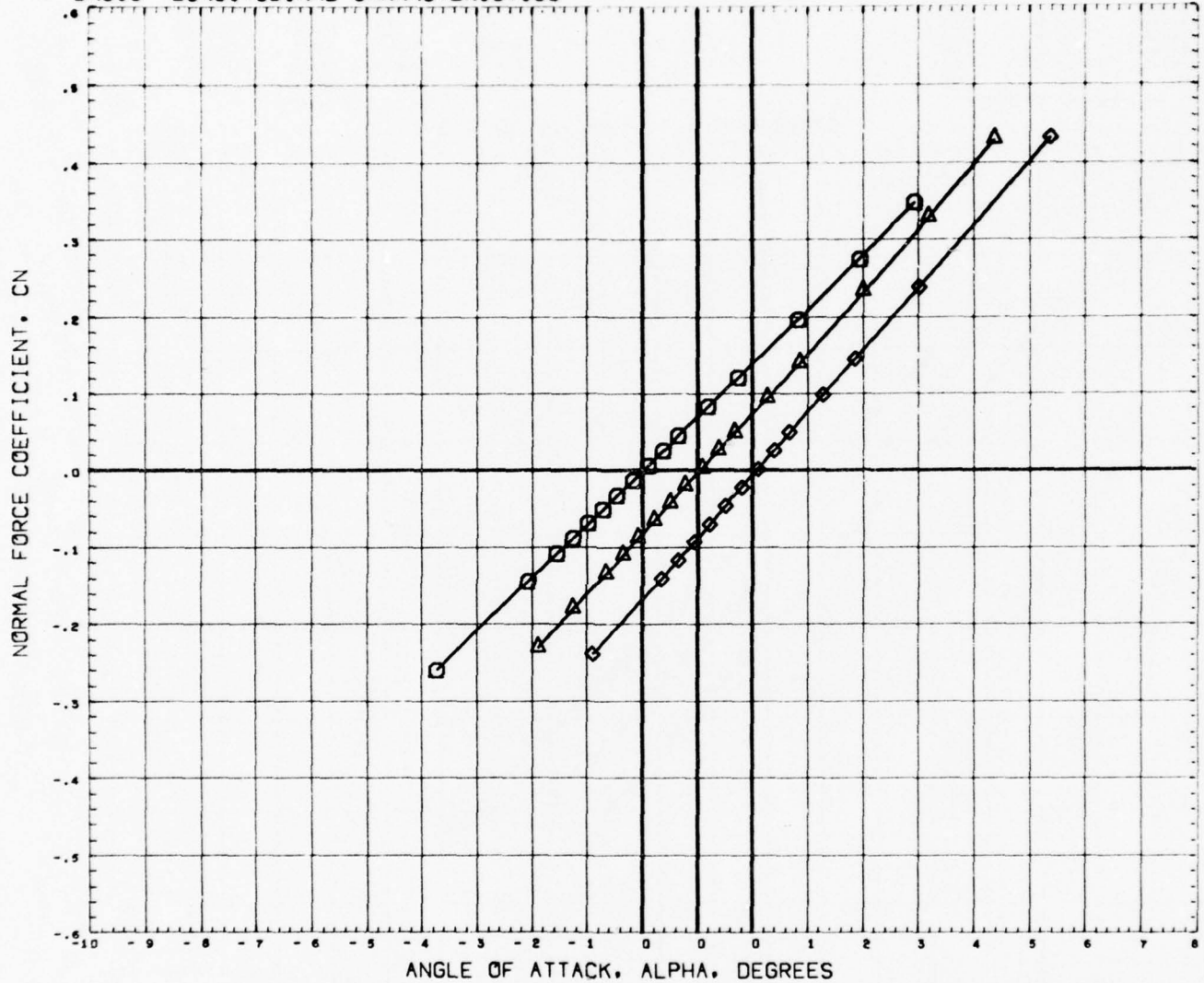

SYMBOL	MACH	PARAMETRIC VALUES				REFERENCE INFORMATION		
○	0.800	PHI	45.000	M-LGTH	1.500	SREF	7.0686	SQ. IN.
△	0.999	LS-LGH	3.250	S-WDTH	0.200	LREF	3.0000	INCHES
◇	1.198	R-WDTH	1.000	C-LGTH	5.000	BREF	3.0000	INCHES
		C-DIA	0.400			YMRP	0.0000	INCHES
						ZMRP	0.0000	INCHES
						SCALE	0.0000	NONE

REFERENCE FILE

BASIC LONGITUDINAL CHARACTERISTICS

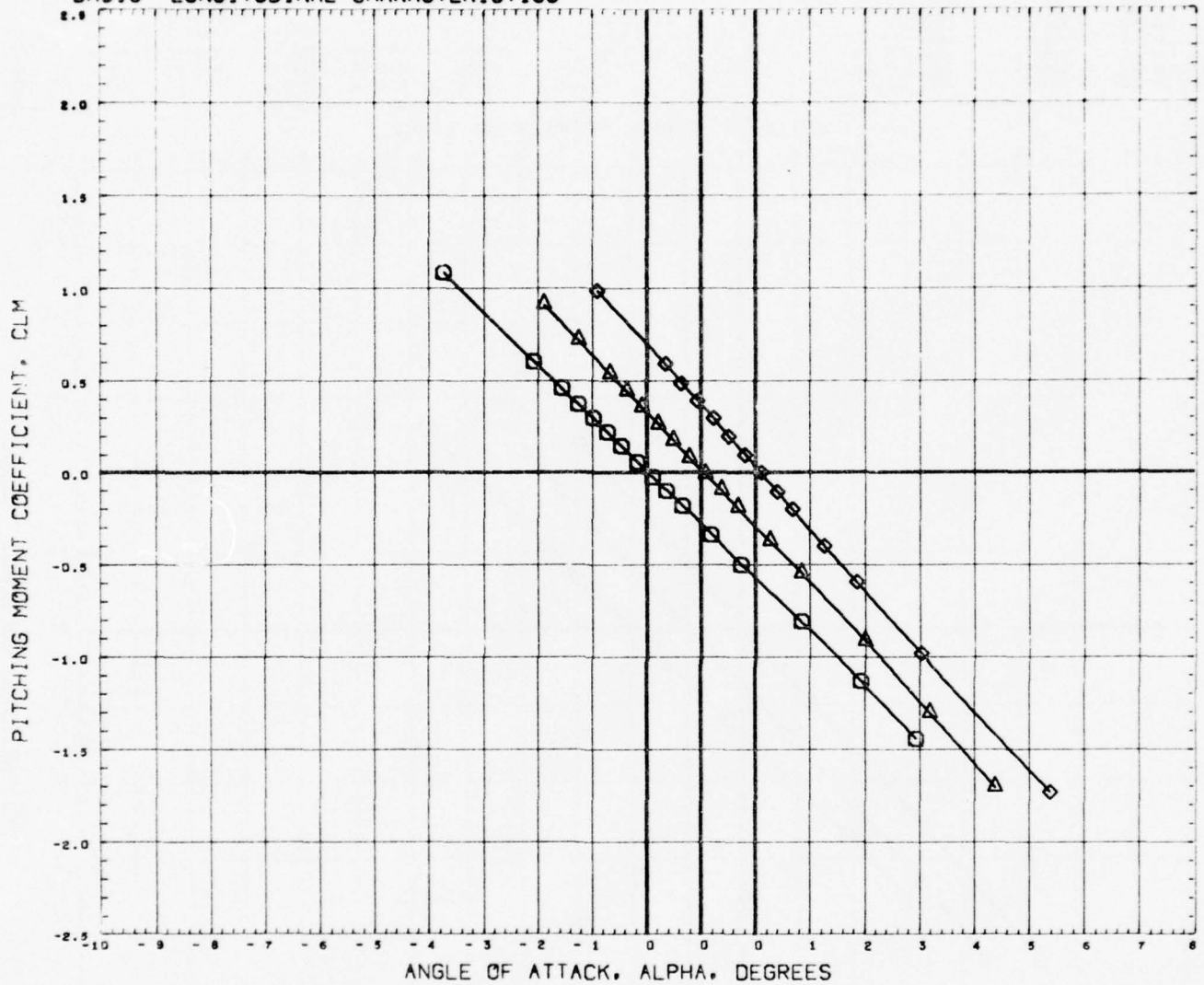

SYMBOL	MACH	PHI	PARAMETRIC VALUES	
○	0.800	45.000	M-LGTH	1.500
△	0.999	LS-LGH	3.250	S-WDTH 0.200
◇	1.198	R-WDTH	1.000	C-LGTH 5.000
		C-DIA	0.400	

REFERENCE INFORMATION		
SREF	7.0686	50. IN.
LREF	3.0000	INCHES
BREF	3.0000	INCHES
XMRP	0.0000	INCHES
YMRP	0.0000	INCHES
ZMRP	0.0000	INCHES
SCALE	0.0000	NONE

REFERENCE FILE

EFFECT OF AFTERBODY LENGTH

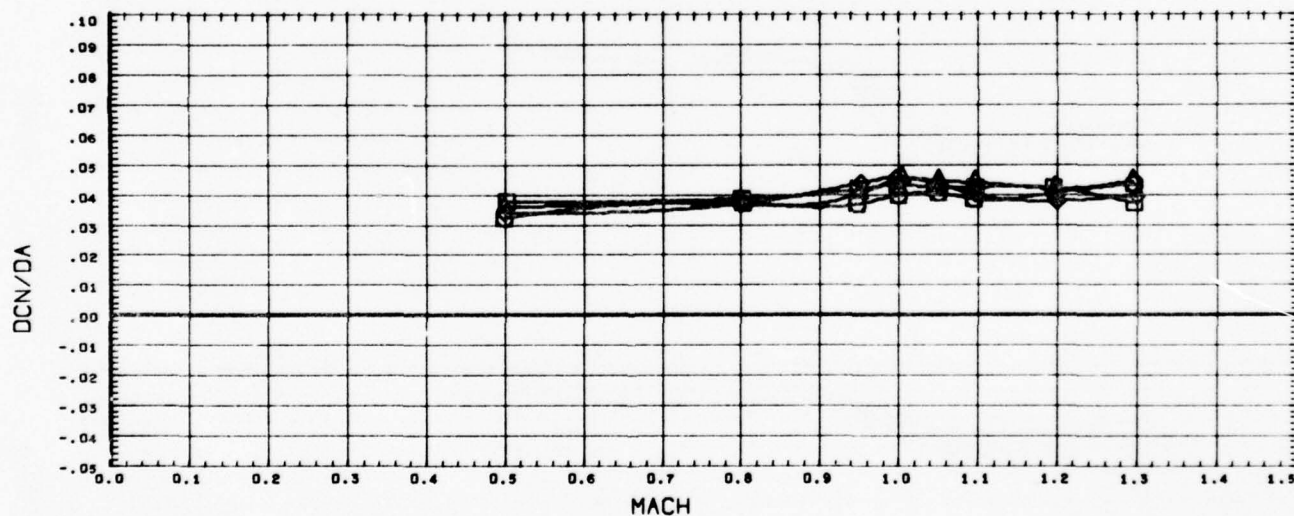
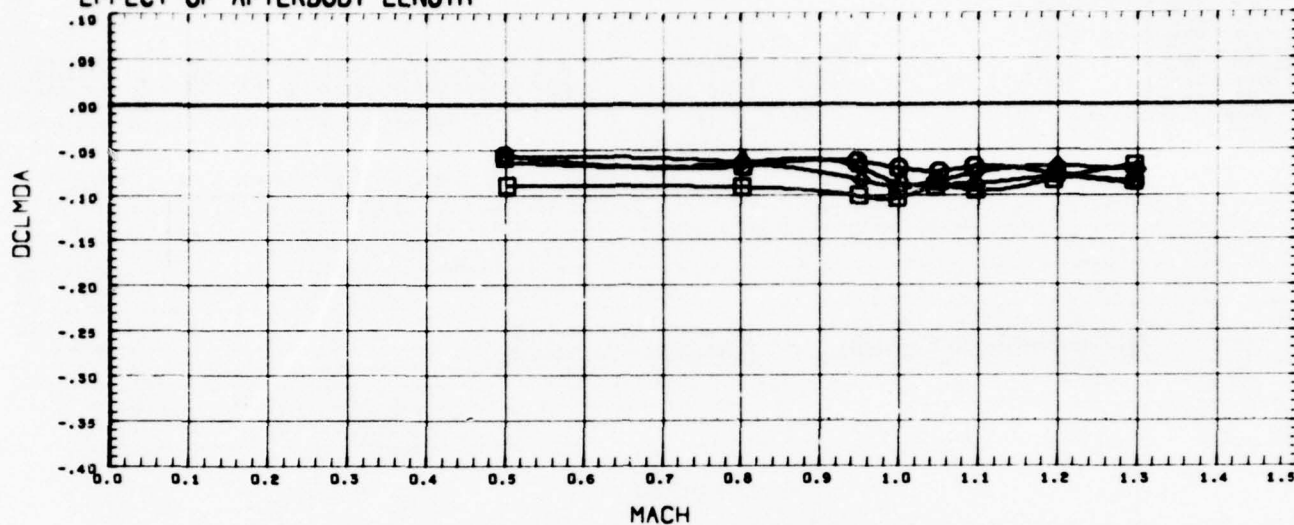

DATA SET SYMBOL	CONFIGURATION DESCRIPTION	PHI	M-LGTH	REFERENCE INFORMATION
(RTAM01)	AEDC TEST PWT-4T201 CONE-CYLINDER, N1M1	0.000	2.250	SREF 7.0686 SQ. IN.
(RTAM02)	AEDC TEST PWT-4T201 CONE-CYLINDER, N1M2	0.000	1.500	LREF 3.0000 INCHES
(RTAM03)	AEDC TEST PWT-4T201 CONE-CYLINDER, N1M3	0.000	0.750	BREF 3.0000 INCHES
(RTAM04)	AEDC TEST PWT-4T201 CONE-CYLINDER, N1M4	0.000	5.750	XWRP 0.0000 INCHES
				YWRP 0.0000 INCHES
				ZWRP 0.0000 INCHES
				SCALE 0.0000 NONE

EFFECT OF AFTERBODY LENGTH

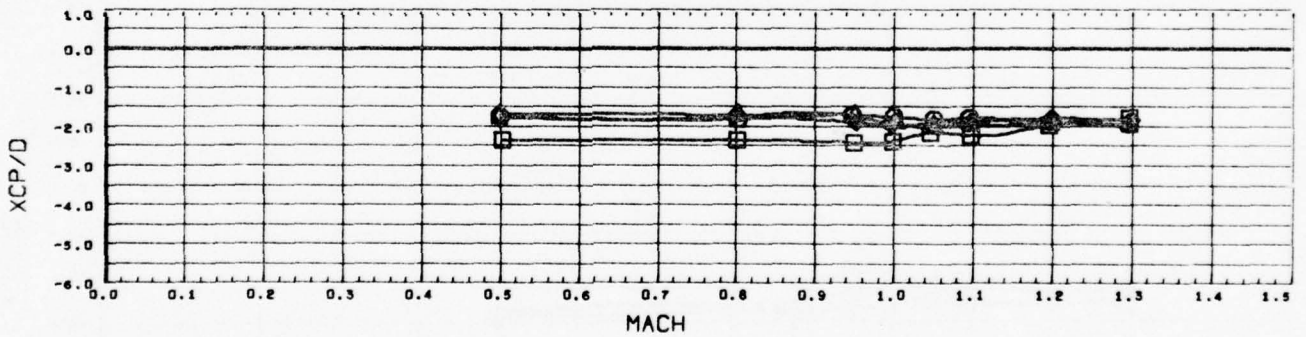
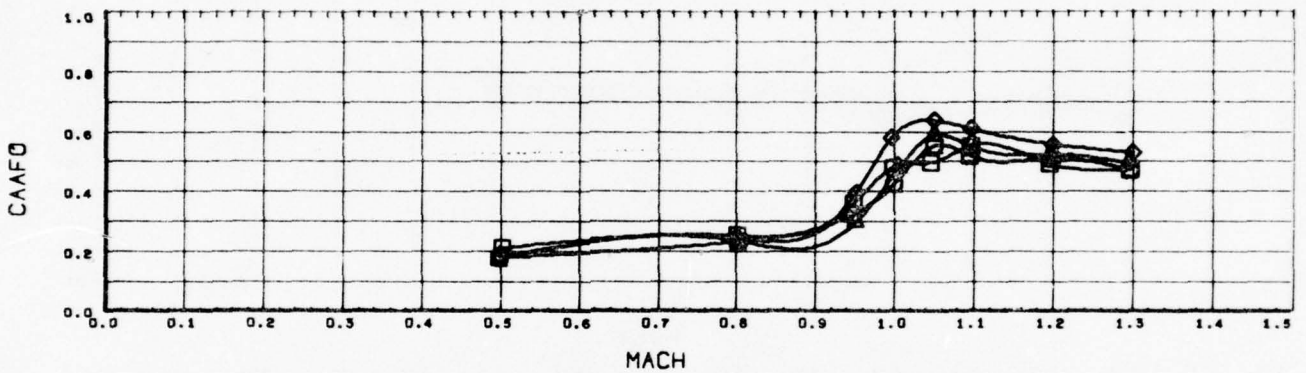
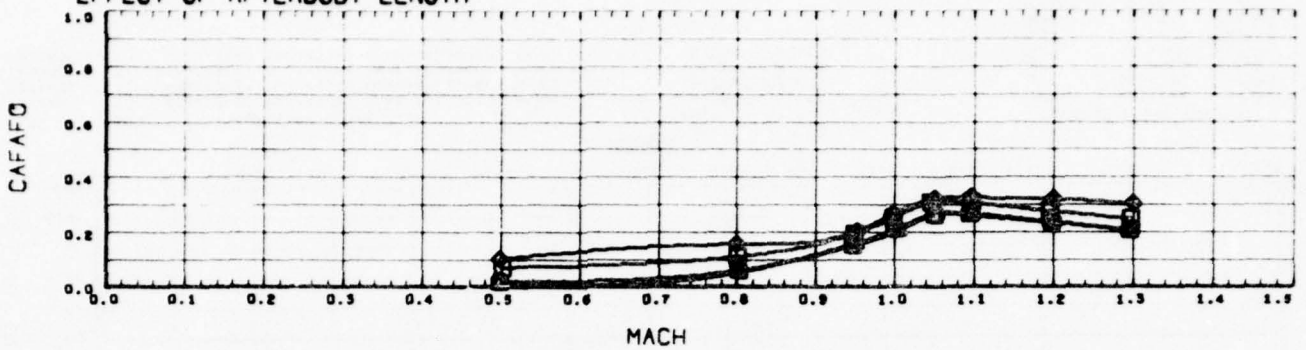

DATA SET SYMBOL	CONFIGURATION DESCRIPTION	PHI	M-LGTH	REFERENCE INFORMATION
(BTAM01)	AEDC TEST PWT-4T201 CONE-CYLINDER, N1M1	0.000	2.240	SREF 7.0686 SQ. IN.
(BTAM02)	AEDC TEST PWT-4T201 CONE-CYLINDER, N1M2	0.000	1.500	LREF 3.0000 INCHES
(BTAM03)	AEDC TEST PWT-4T201 CONE-CYLINDER, N1M3	0.000	0.750	BREF 3.0000 INCHES
(BTAM04)	AEDC TEST PWT-4T201 CONE-CYLINDER, N1M4	0.000	5.750	XMRP 0.0000 INCHES
				YMRP 0.0000 INCHES
				ZMRP 0.0000 INCHES
				SCALE 0.0000 NONE

EFFECT OF AFTERBODY LENGTH WITH CENTERBODY

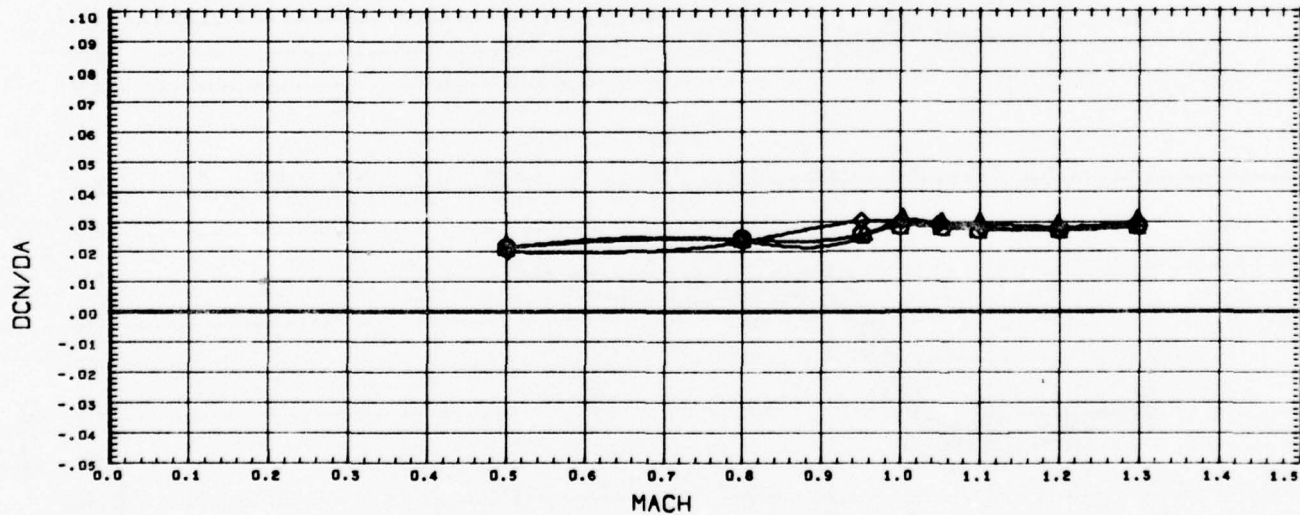
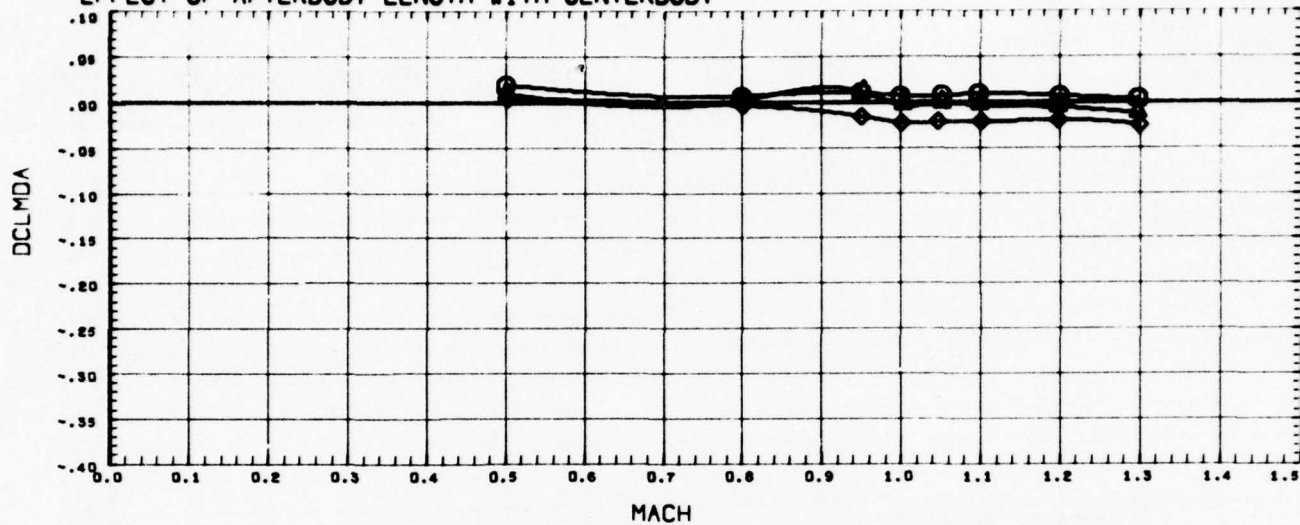

DATA SET SYMBOL	CONFIGURATION DESCRIPTION	PHI	M-LGTH	C-LGTH	C-DIA	REFERENCE INFORMATION
(RTAM05)	AEDC TEST PWT-4T201 CONE-CYLINDER, N1M1C1	0.000	2.2*0	5.000	0.400	SREF 7.0686 50. IN.
(CTAM06)	AEDC TEST PWT-4T201 CONE-CYLINDER, N1M2C1	0.000	1.500	5.000	0.400	LREF 3.0000 INCHES
(RTAM07)	AEDC TEST PWT-4T201 CONE-CYLINDER, N1M3C1	0.000	0.750	5.000	0.400	BREF 3.0000 INCHES YMRP 0.0000 INCHES YMRP 0.0000 INCHES ZMRP 0.0000 INCHES SCALE 0.0000 NONE

EFFECT OF AFTERBODY LENGTH WITH CENTERBODY

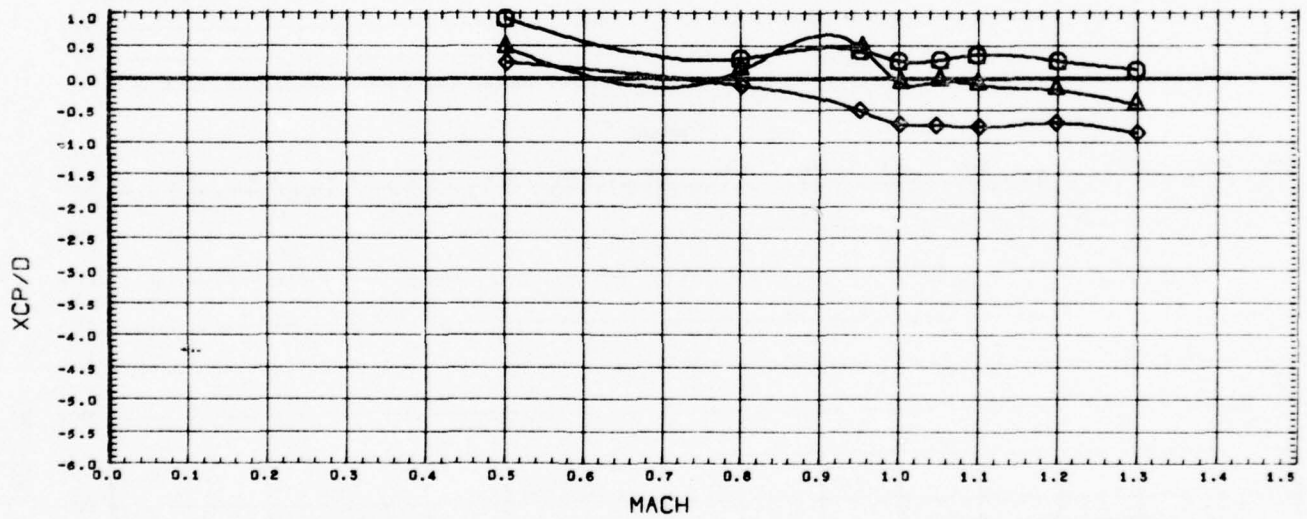
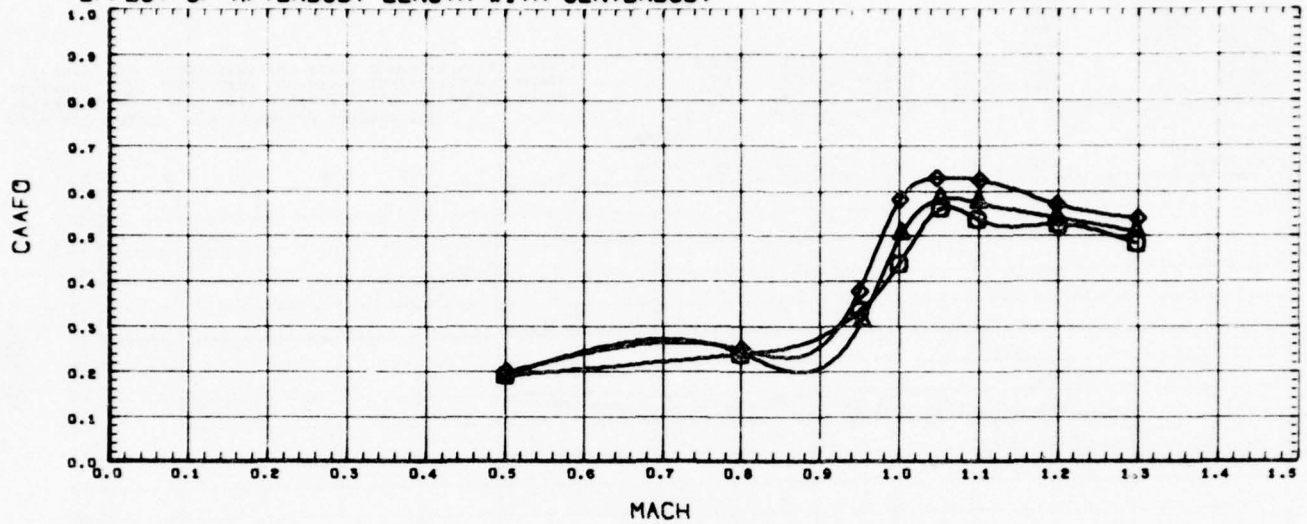

DATA SET SYMBOL	CONFIGURATION DESCRIPTION	PHI	M-LGTH	C-LGTH	C-DIA	REFERENCE INFORMATION
(BTAM05)	⊙ AEDC TEST PWT-4T201 CONE-CYLINDER, N1M1C1	0.000	2.240	5.000	0.400	SREF 7.0686 SQ. IN.
(BTAM06)	△ AEDC TEST PWT-4T201 CONE-CYLINDER, N1M2C1	0.000	1.500	5.000	0.400	LREF 3.0000 INCHES
(BTAM07)	◇ AEDC TEST PWT-4T201 CONE-CYLINDER, N1M3C1	0.000	0.750	5.000	0.400	BREF 3.0000 INCHES
						XMRP 0.0000 INCHES
						YMRP 0.0000 INCHES
						ZMRP 0.0000 INCHES
						SCALE 0.0000 NONE

CENTERBODY DIAMETER EFFECT (NO RING)

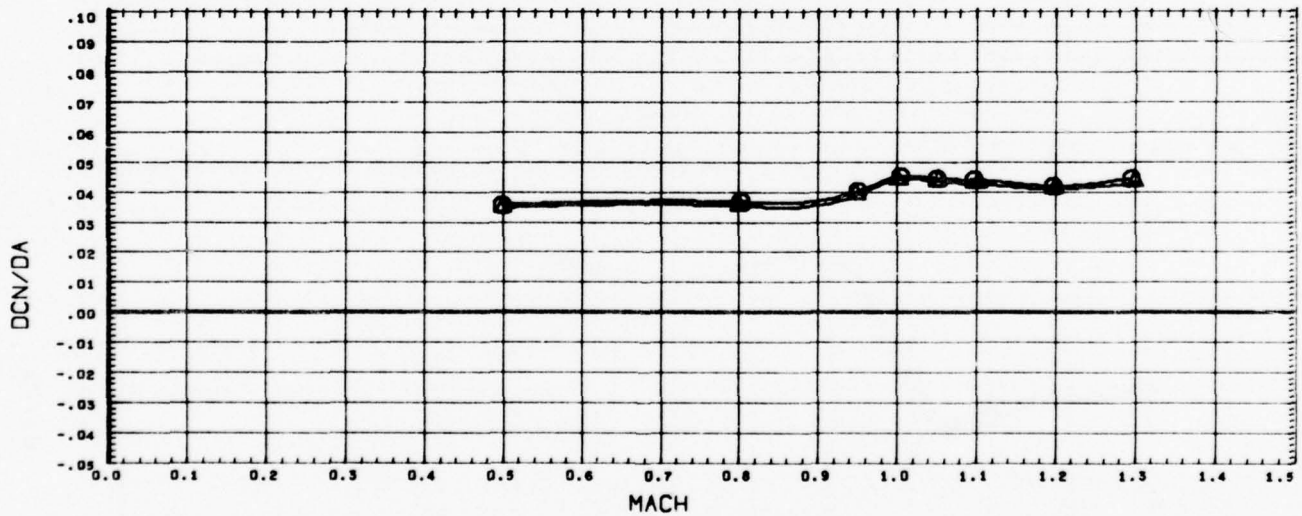
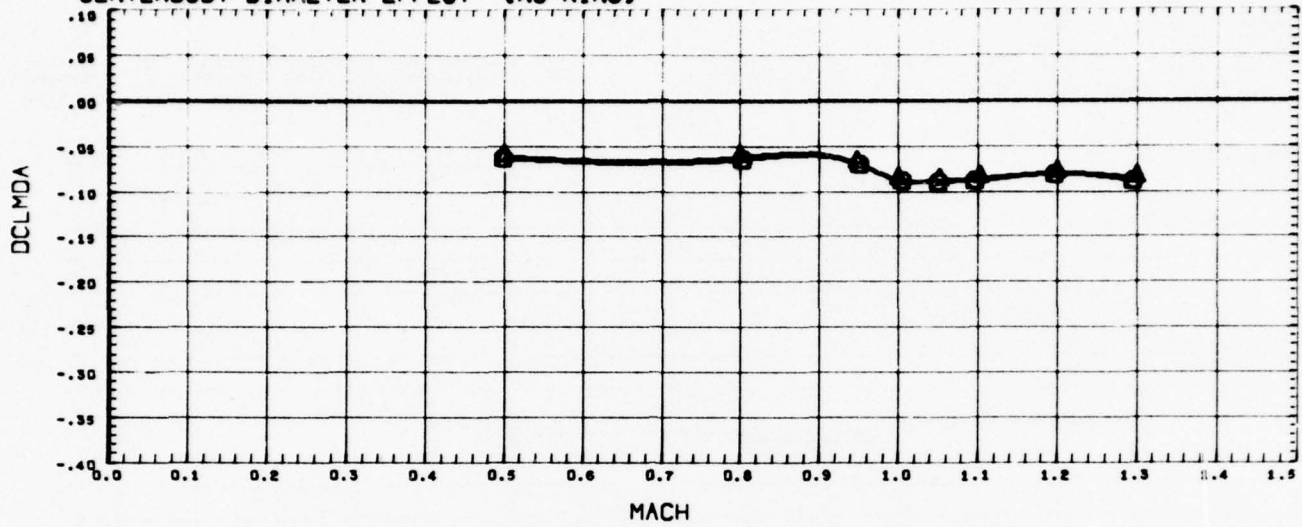

DATA SET SYMBOL	CONFIGURATION DESCRIPTION
(RTAM02)	AEDC TEST PWT-4T201 CONE-CYLINDER, N1M2
(RTAM12)	AEDC TEST PWT-4T201 CONE-CYLINDER, N1M2CS

PHI	M-LGTH	C-LGTH	C-DIA
0.000	1.500		
0.000	1.500	5.000	0.400

REFERENCE INFORMATION	
SREF	7.0686 SQ. IN.
LREF	3.0000 INCHES
BREF	3.0000 INCHES
XMRP	0.0000 INCHES
YMRP	0.0000 INCHES
ZMRP	0.0000 INCHES
SCALE	0.0000 NONE

CENTERBODY DIAMETER EFFECT (NO RING)

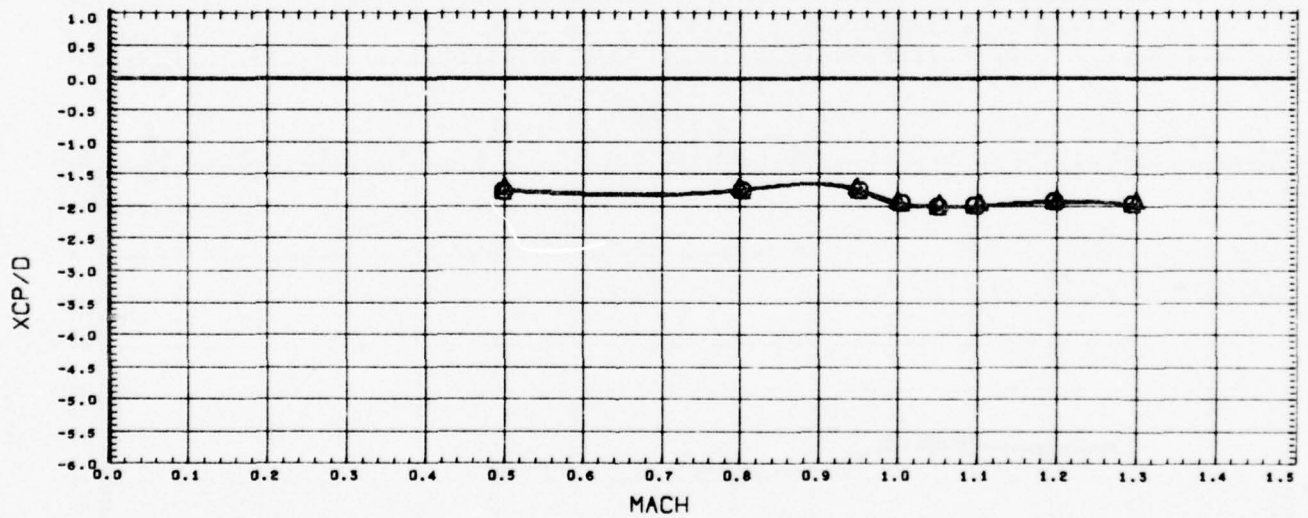
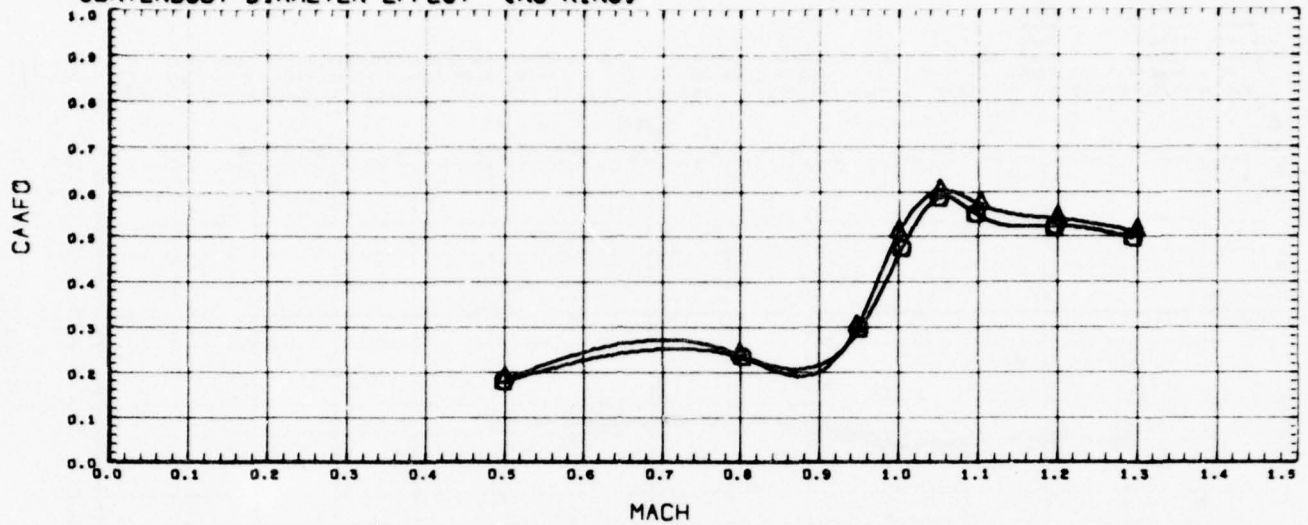

DATA SET SYMBOL	CONFIGURATION DESCRIPTION	PHI	M-LGTH	C-LGTH	C-DIA	REFERENCE INFORMATION
(BTAM02)	⊙ AEDC TEST PWT-4T201 CONE-CYLINDER, N1M2	0.000	1.500	5.000	0.400	SREF 7.0686 SQ. IN. LREF 3.0000 INCHES BREF 3.0000 INCHES XMRP 0.0000 INCHES YMRP 0.0000 INCHES ZMRP 0.0000 INCHES SCALE 0.0000 NONE
(BTAM12)	⊙ AEDC TEST PWT-4T201 CONE-CYLINDER, N1M2C5	0.000	1.500	5.000	0.400	

CENTERBODY DIAMETER EFFECT (NO RING)

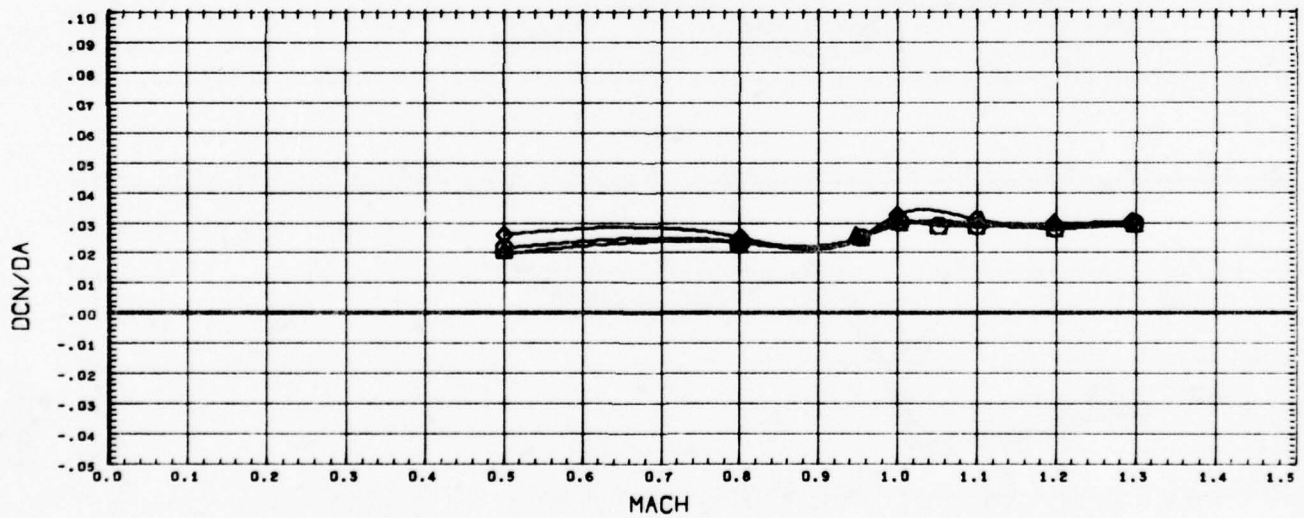
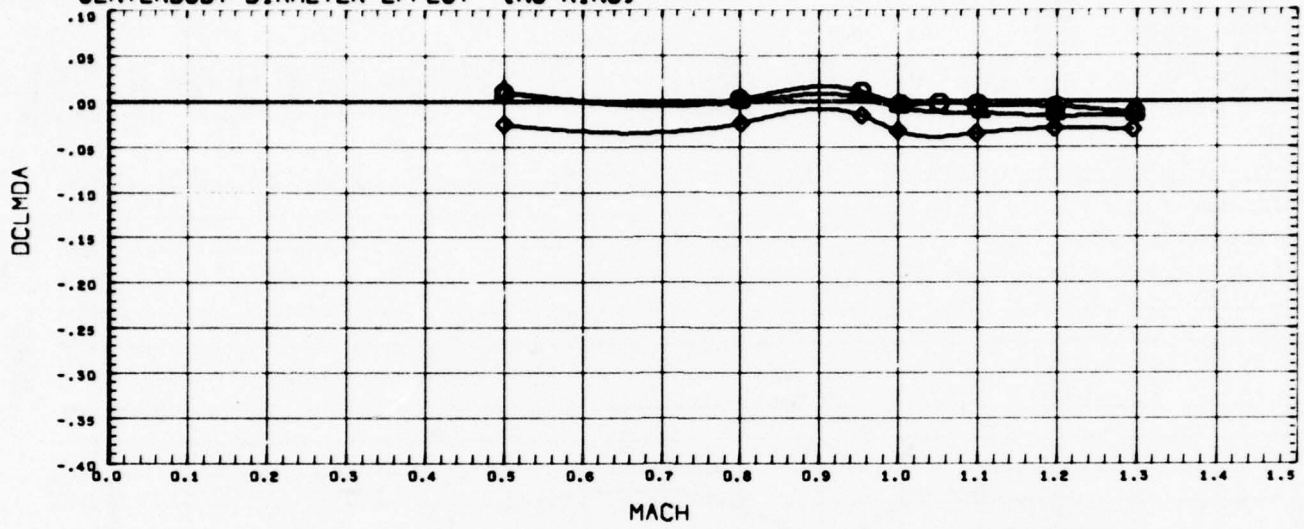

DATA SET SYMBOL	CONFIGURATION DESCRIPTION	PHI	M-LGTH	C-LGTH	C-DIA	REFERENCE INFORMATION
(CTAM06)	AEDC TEST PWT-4T201 CONE-CYLINDER, N1M2C1	0.000	1.500	5.000	0.400	SREF 7.0686 SQ. IN.
(RTAM10)	AEDC TEST PWT-4T201 CONE-CYLINDER, N1M2C2	0.000	1.500	5.000	0.500	LREF 3.0000 INCHES
(RTAM11)	AEDC TEST PWT-4T201 CONE-CYLINDER, N1M2C3	0.000	1.500	5.000	0.670	BREF 3.0000 INCHES
						XMRP 0.0000 INCHES
						YMRP 0.0000 INCHES
						ZMRP 0.0000 INCHES
						SCALE 0.0000 NONE

CENTERBODY DIAMETER EFFECT (NO RING)

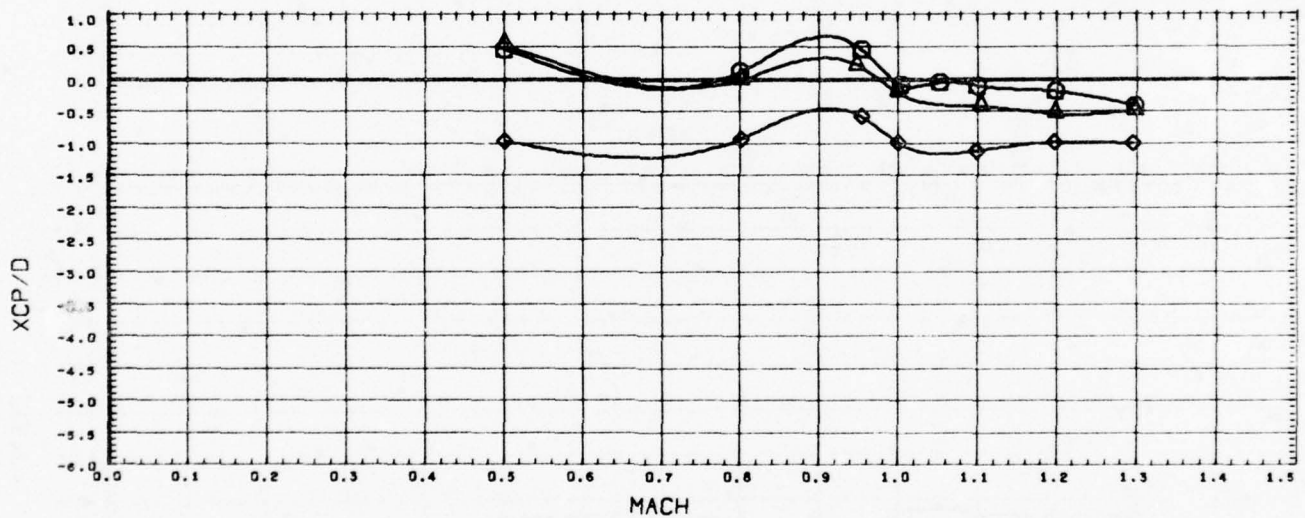
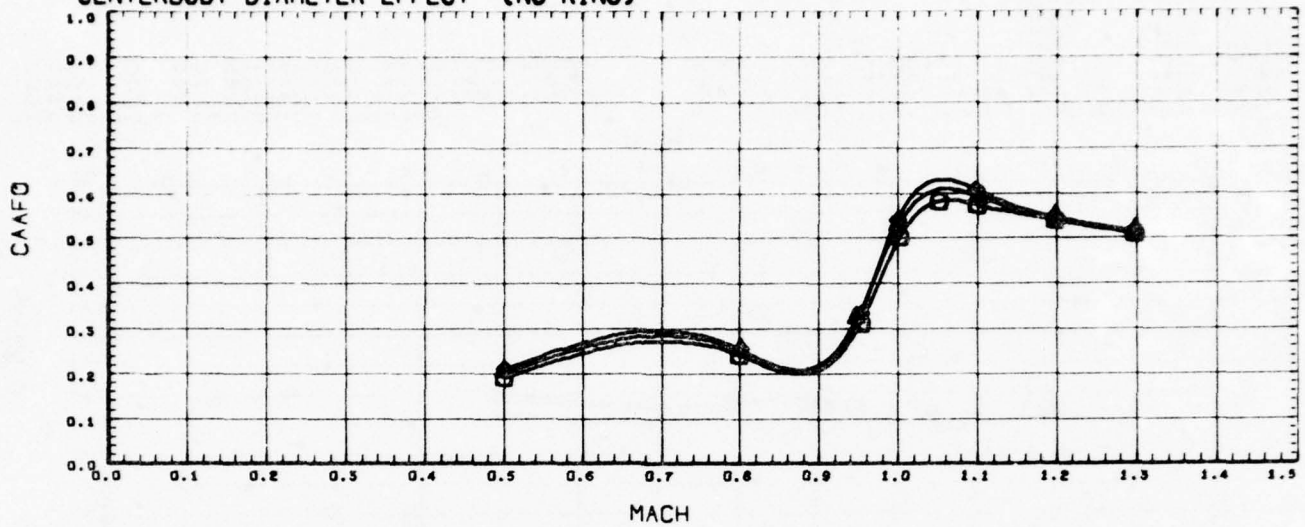

DATA SET SYMBOL	CONFIGURATION DESCRIPTION	PHI	M-LGTH	C-LGTH	C-DIA	REFERENCE INFORMATION
(BTAM06)	AEDC TEST PWT-4T2D1 CONE-CYLINDER, N1M2C1	0.000	1.570	5.000	0.400	SREF 7.0686 SQ. IN.
(BTAM10)	AEDC TEST PWT-4T2D1 CONE-CYLINDER, N1M2C2	0.000	1.500	5.000	0.500	LREF 3.0000 INCHES
(BTAM11)	AEDC TEST PWT-4T2D1 CONE-CYLINDER, N1M2C3	0.000	1.500	5.000	0.670	BREF 3.0000 INCHES XMRP 0.0000 INCHES YMRP 0.0000 INCHES ZMRP 0.0000 INCHES SCALE 0.0000 NONE

CENTERBODY DIAMETER EFFECT (WITH RING)

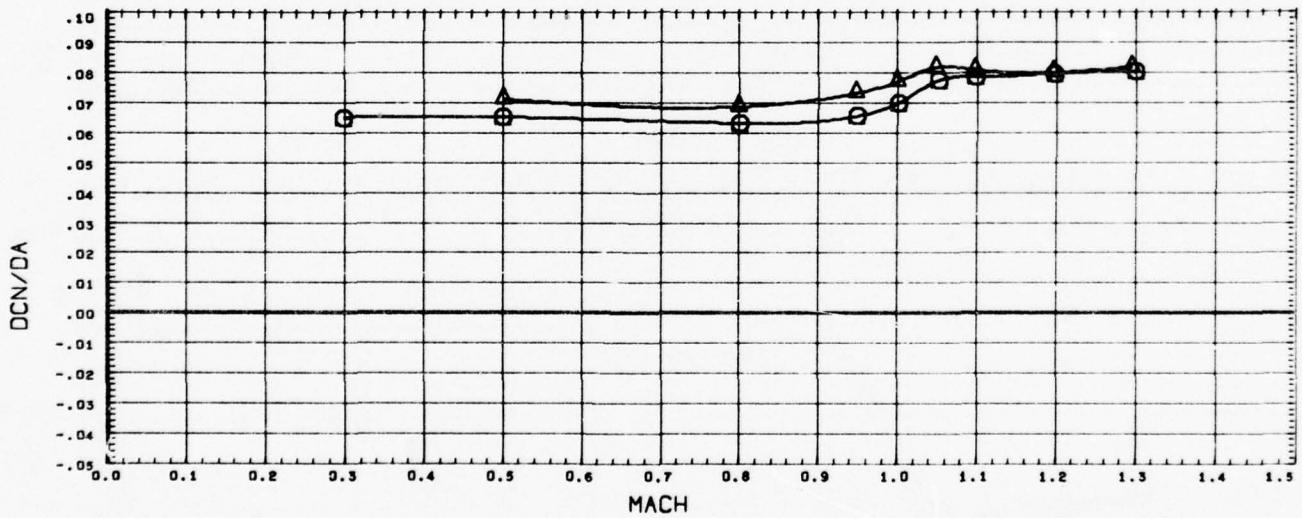
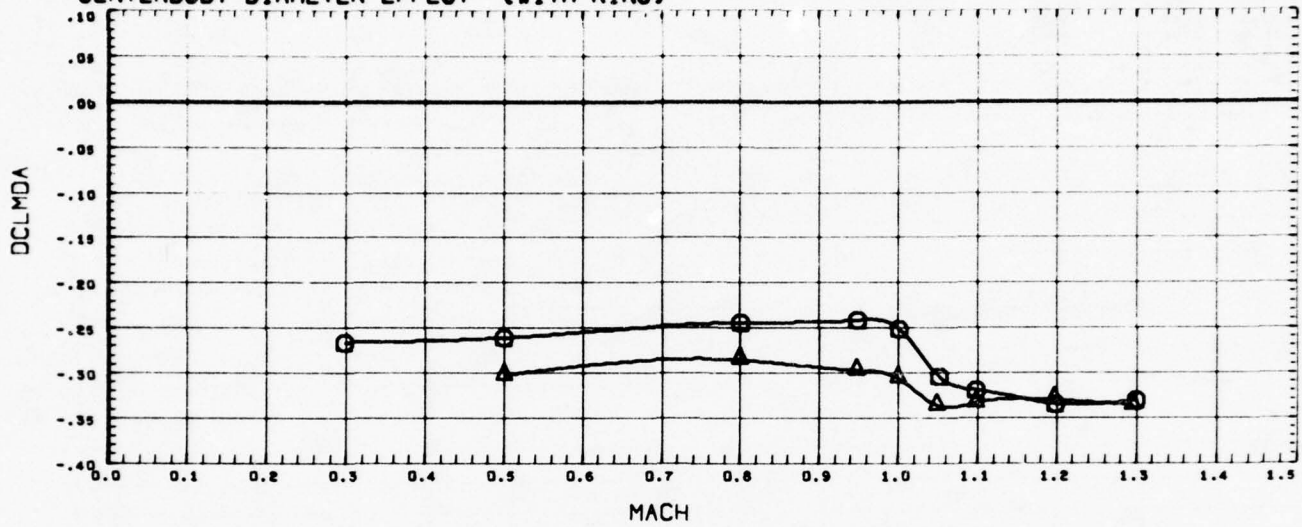

DATA SET SYMBOL	CONFIGURATION DESCRIPTION	PHI	M-LGTH	C-LGTH	C-DIA	REFERENCE INFORMATION
(CTAR02)	AEDC TEST PWI-4T201 CONE-CYL. W/RING TAIL, N1R2	0.000	1.500			SREF 7.0686 SQ. IN.
(RTAR25)	AEDC TEST PWI-4T201 CONE-CYL. W/RING TAIL, N1R2C5	0.000	1.500	5.000	0.400	LREF 3.0000 INCHES BREF 3.0000 INCHES XMRP 0.0000 INCHES YMRP 0.0000 INCHES ZMRP 0.0000 INCHES SCALE 0.0000 NONE

CENTERBODY DIAMETER EFFECT (WITH RING)

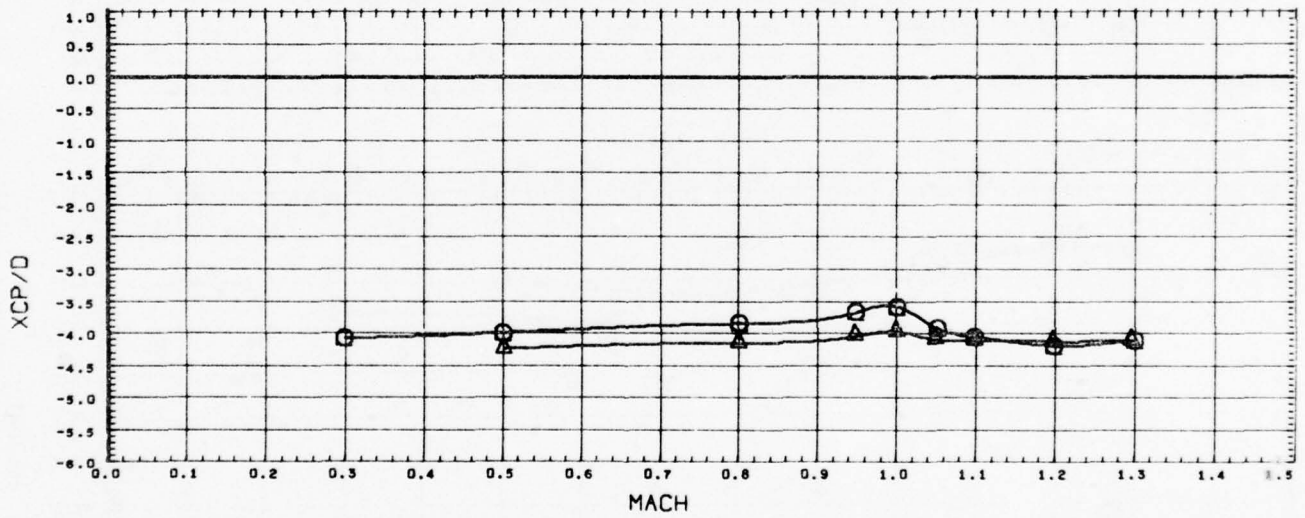
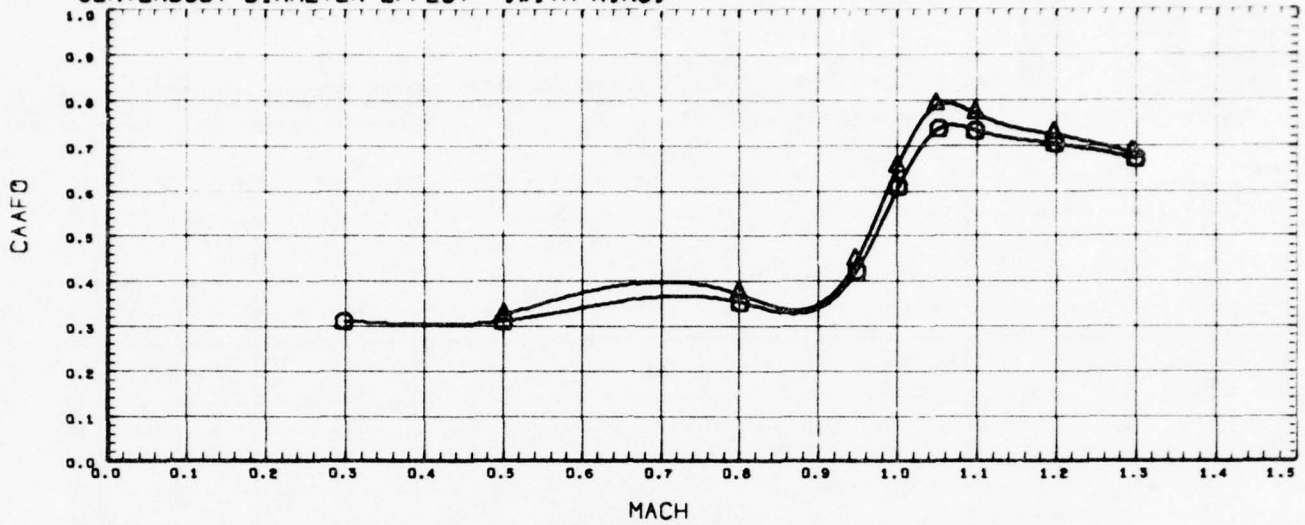

DATA SET SYMBOL	CONFIGURATION DESCRIPTION	PHI	M-LGTH	C-LGTH	C-DIA	REFERENCE INFORMATION
(BTAR02)	⊙ AEDC TEST PWT-4T201 CONE-CYL. W/RING TAIL, N1R2	0.000	1.500			SREF 7.0686 SQ. IN.
(BTAR25)	△ AEDC TEST PWT-4T201 CONE-CYL. W/RING TAIL, N1R2C5	0.000	1.500	5.000	0.400	LREF 3.0000 INCHES BREF 3.0000 INCHES XNRP 0.0000 INCHES YNRP 0.0000 INCHES ZNRP 0.0000 INCHES SCALE 0.0000 NONE

CENTERBODY DIAMETER EFFECT (WITH RING)

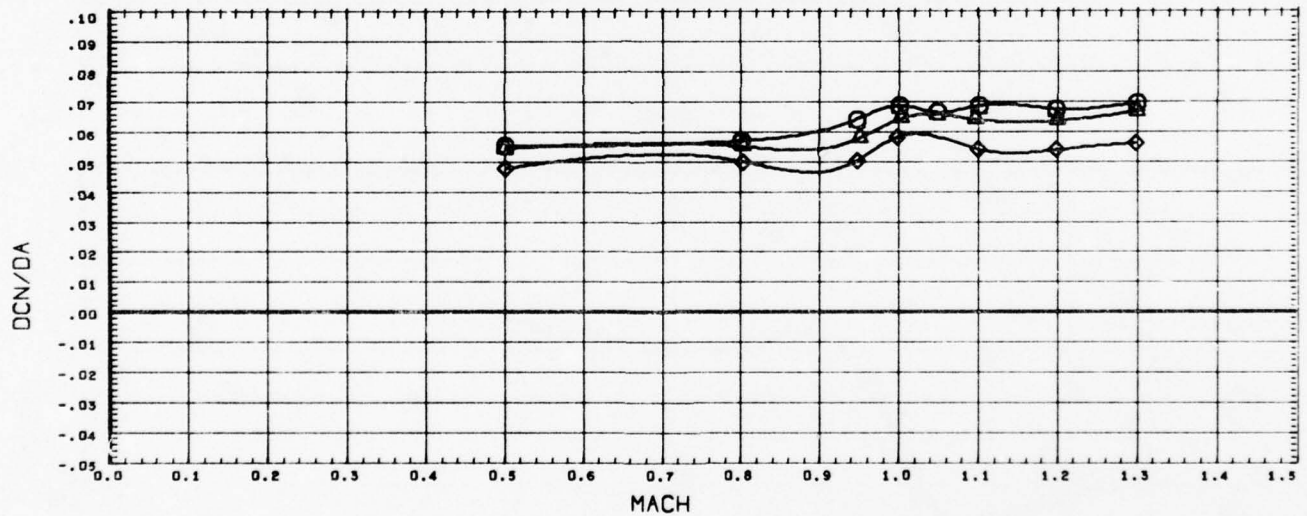
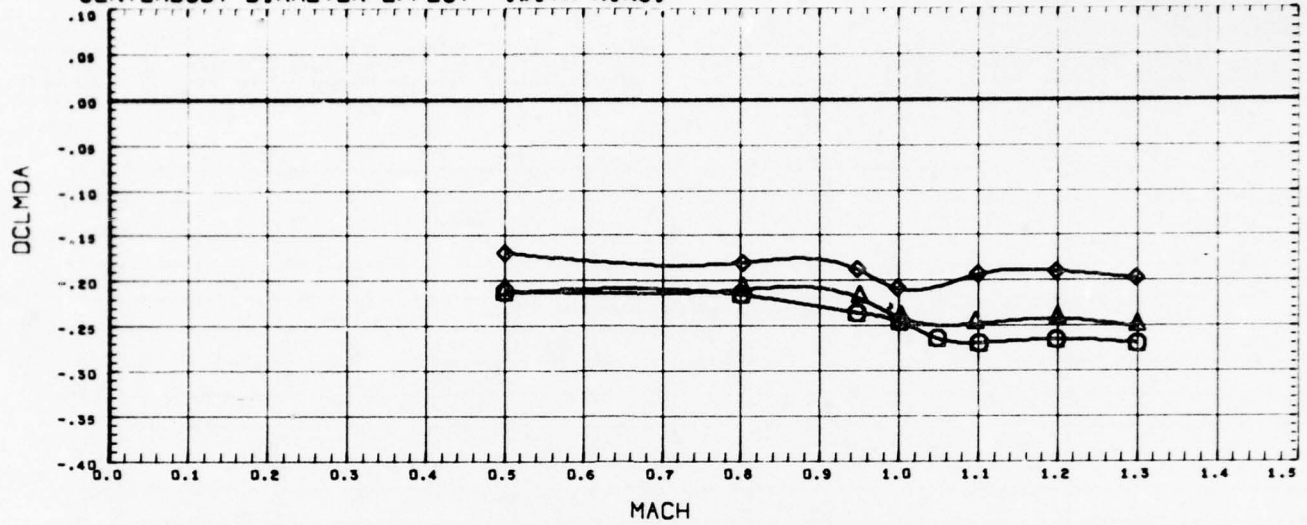

DATA SET SYMBOL	CONFIGURATION DESCRIPTION	PHI	M-LGTH	C-LGTH	C-DIA	REFERENCE INFORMATION
(RTAR09)	⊙ AEDC TEST PWT-4T201 CONE-CYL. W/RING TAIL,N1R2C1	0.000	1.500	5.000	0.400	SREF 7.0686 SQ. IN.
(RTAR18)	△ AEDC TEST PWT-4T201 CONE-CYL. W/RING TAIL,N1R2C2	0.000	1.500	5.000	0.500	LREF 3.0000 INCHES
(RTAR20)	◇ AEDC TEST PWT-4T201 CONE-CYL. W/RING TAIL,N1R2C3	0.000	1.500	5.000	0.670	BREF 3.0000 INCHES
						XWRP 0.0000 INCHES
						YWRP 0.0000 INCHES
						ZWRP 0.0000 INCHES
						SCALE 0.0000 NONE

CENTERBODY DIAMETER EFFECT (WITH RING)

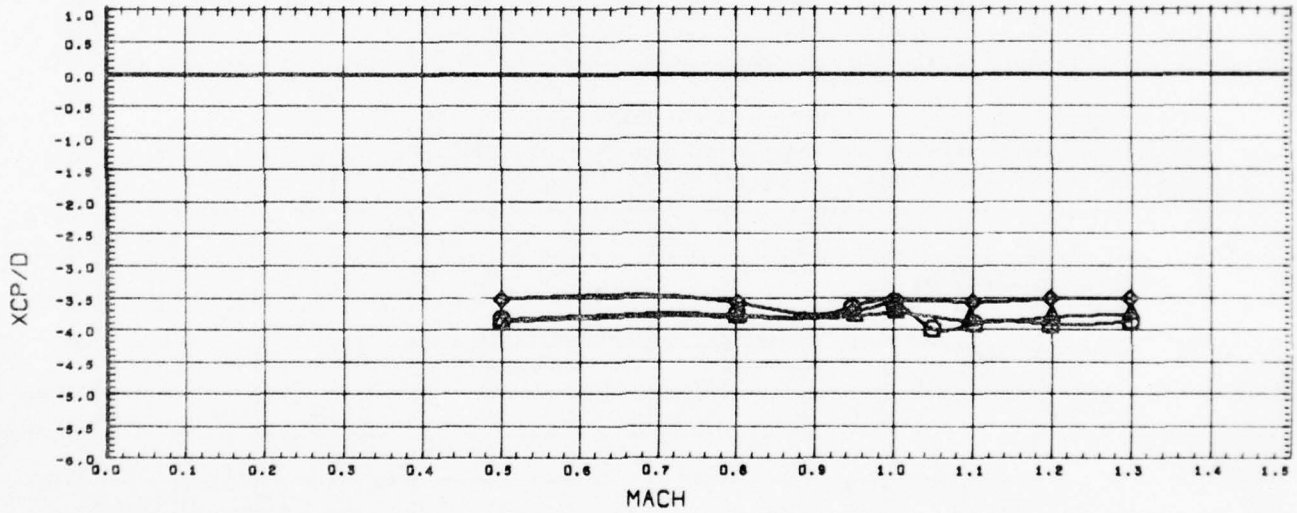
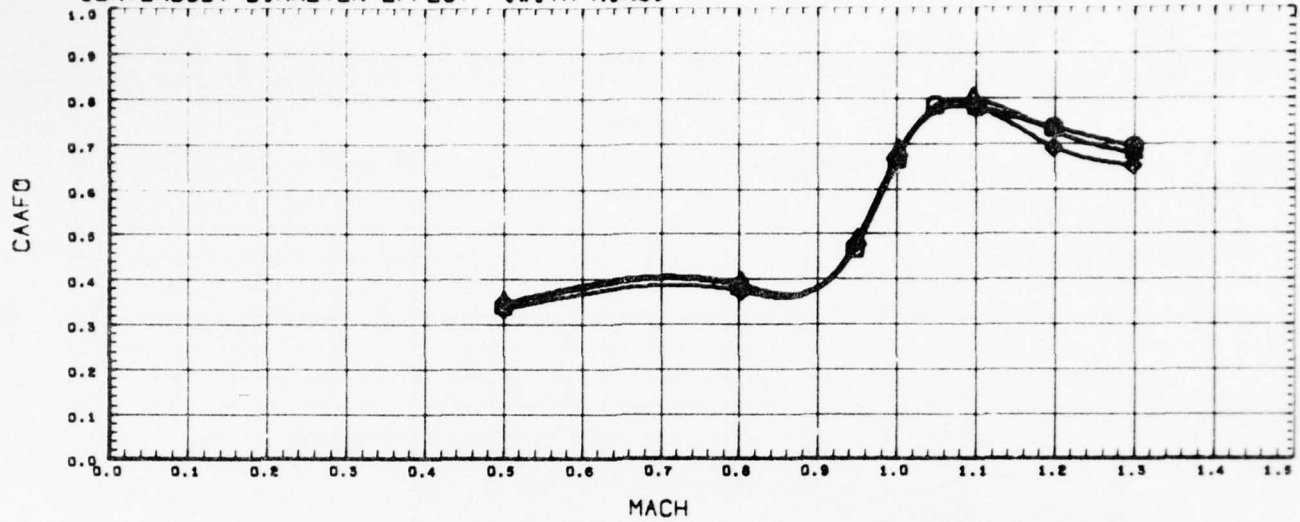

DATA SET SYMBOL	CONFIGURATION DESCRIPTION	PHI	M-LGTH	C-LGTH	C-DIA	REFERENCE INFORMATION
(BTAR09)	AEDC TEST PWT-4T2D1 CONE-CYL. W/RING TAIL,N1R2C1	0.000	1.500	5.000	0.400	SREF 7.0686 SQ. IN.
(BTAR18)	AEDC TEST PWT-4T2D1 CONE-CYL. W/RING TAIL,N1R2C2	0.000	1.500	5.000	0.500	LREF 3.0000 INCHES
(BTAR20)	AEDC TEST PWT-4T2D1 CONE-CYL. W/RING TAIL,N1R2C3	0.000	1.500	5.000	0.670	BREF 3.0000 INCHES
						XMRP 0.0000 INCHES
						YMRP 0.0000 INCHES
						ZMRP 0.0000 INCHES
						SCALE 0.0000 NONE

EFFECT OF AFTERBODY LENGTH AND CENTERBODY

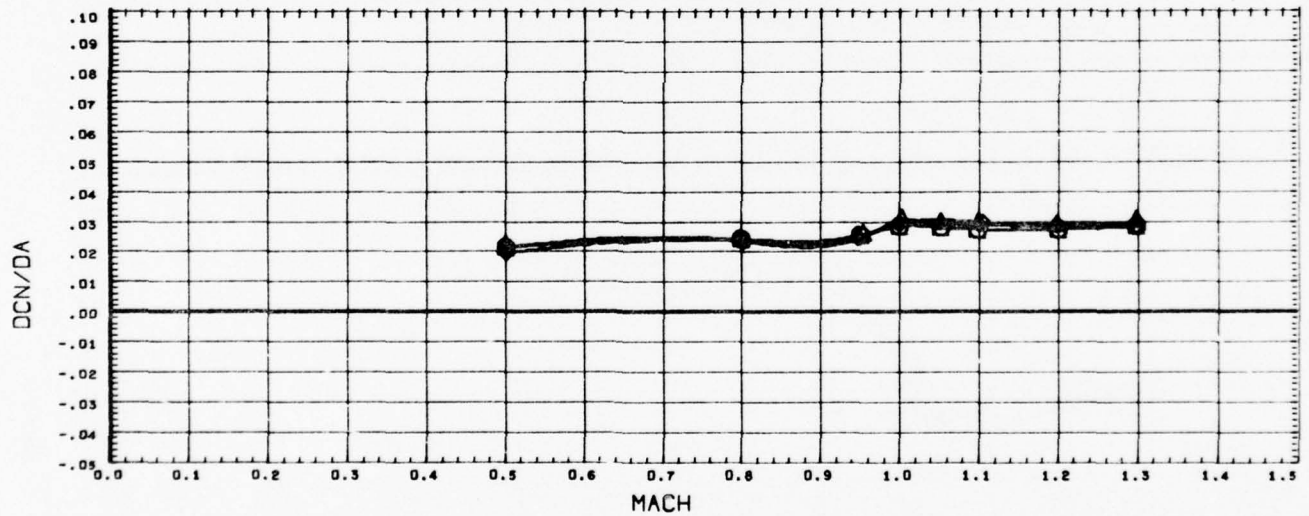
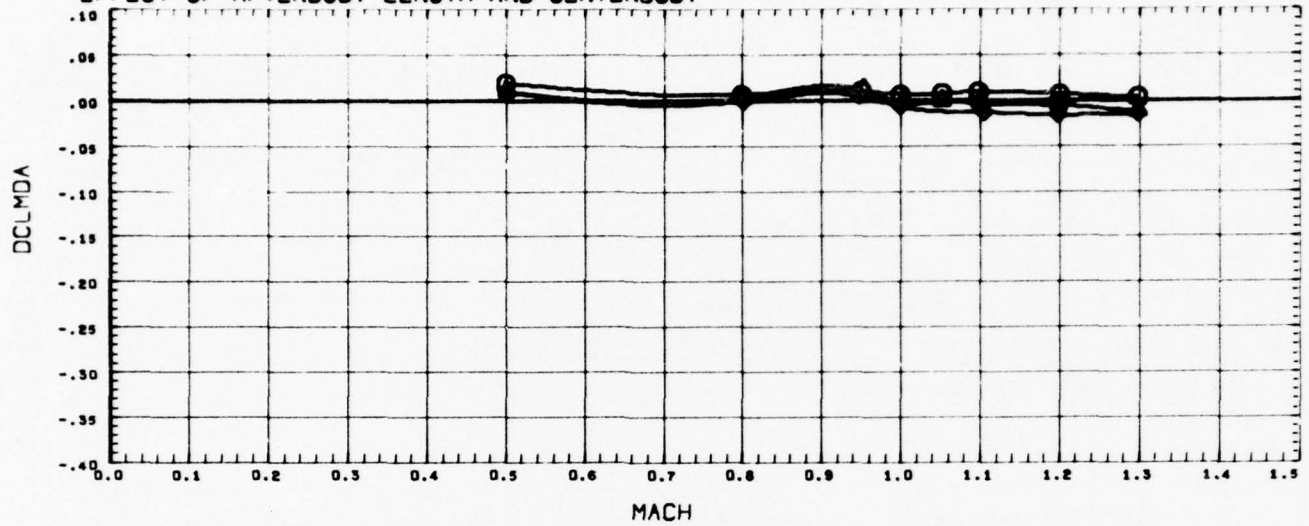

DATA SET SYMBOL	CONFIGURATION DESCRIPTION	PHI	M-LGTH	C-LGTH	C-DIA	REFERENCE INFORMATION
(RTAM05)	AEDC TEST PWT-4T201 CONE-CYLINDER, N1M1C1	0.000	2.250	5.000	0.400	SREF 7.0686 SQ. IN.
(CTAM06)	AEDC TEST PWT-4T201 CONE-CYLINDER, N1M2C1	0.000	1.500	5.000	0.400	LREF 3.0000 INCHES
(RTAM10)	AEDC TEST PWT-4T201 CONE-CYLINDER, N1M2C2	0.000	1.500	5.000	0.500	BREF 3.0000 INCHES XMRP 0.0000 INCHES YMRP 0.0000 INCHES ZMRP 0.0000 INCHES SCALE 0.0000 NONE

EFFECT OF AFTERBODY LENGTH AND CENTERBODY

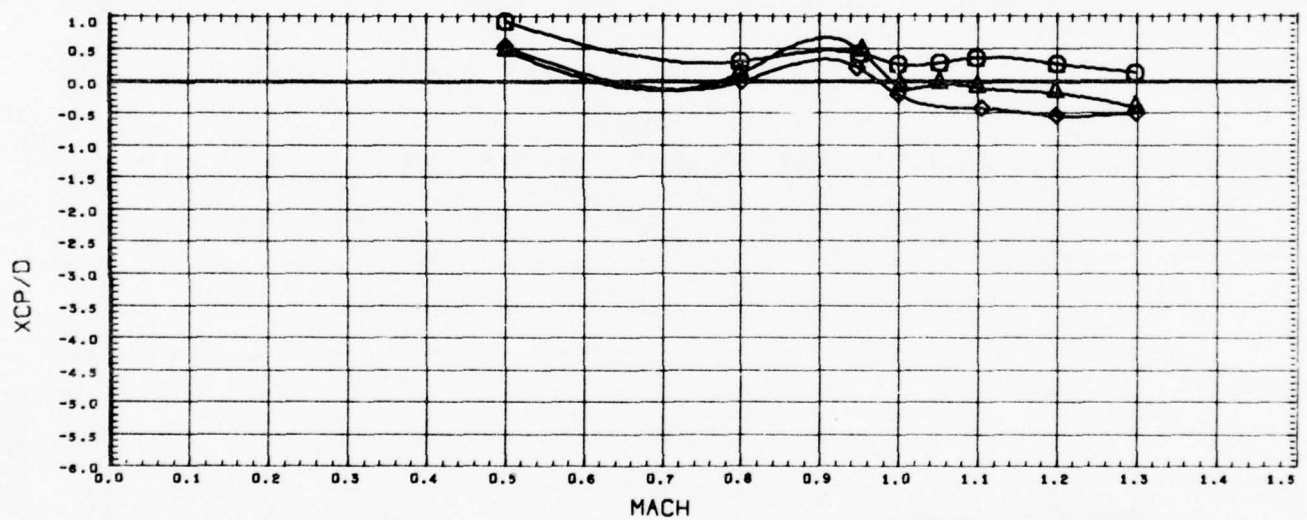
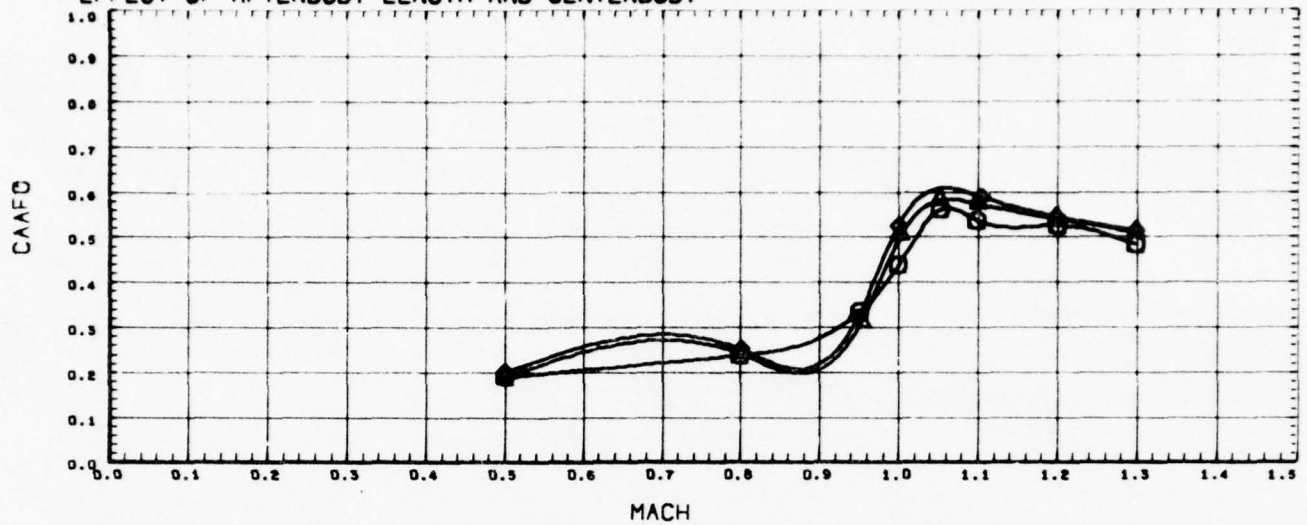

DATA SET SYMBOL	CONFIGURATION DESCRIPTION	PHI	M-LGTH	C-LGTH	C-DIA	REFERENCE INFORMATION
(BTAM05)	⊙ AEDC TEST PWT-4T201 CONE-CYLINDER, N1M1C1	0.000	2.2*0	5.000	0.400	SREF 7.0686 50. IN.
(BTAM06)	⊙ AEDC TEST PWT-4T201 CONE-CYLINDER, N1M2C1	0.000	1.500	5.000	0.400	LREF 3.0000 INCHES
(BTAM10)	◇ AEDC TEST PWT-4T201 CONE-CYLINDER, N1M2C2	0.000	1.500	5.000	0.500	BREF 3.0000 INCHES
						XMRP 0.0000 INCHES
						YMRP 0.0000 INCHES
						ZMRP 0.0000 INCHES
						SCALE 0.0000 NONE

EFFECT OF AFTERBODY LENGTH AND CENTERBODY

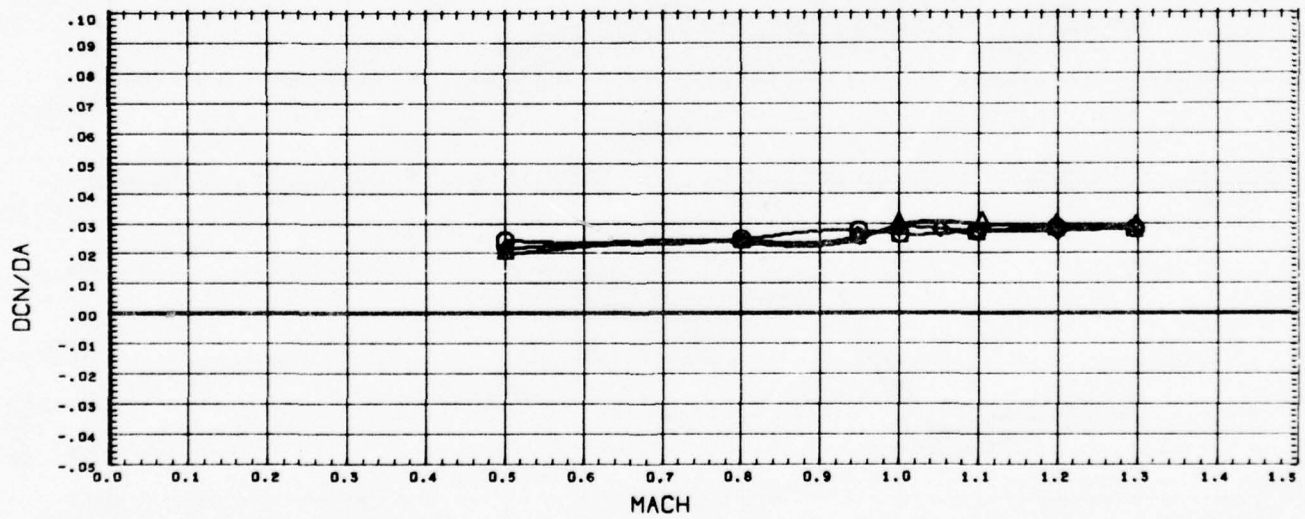
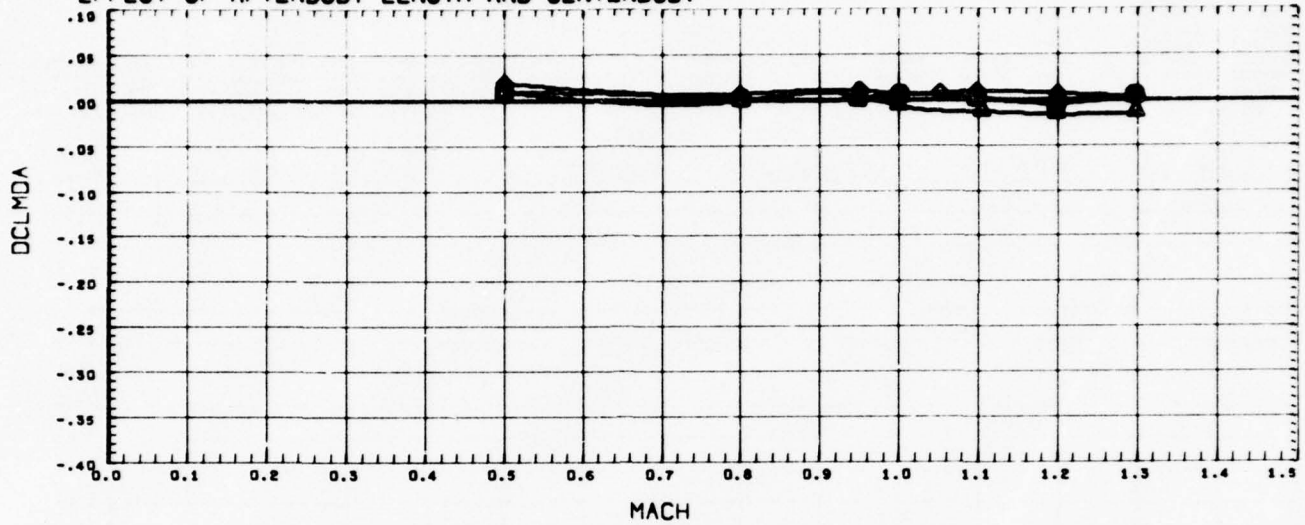

DATA SET SYMBOL	CONFIGURATION DESCRIPTION	PHI	M-LGTH	C-LGTH	C-DIA	REFERENCE INFORMATION
(RTAM13)	AEDC TEST PWT-4T201 CONE-CYLINDER, N1M1C4	0.000	2.2*0	6.500	0.500	SREF 7.0686 50. IN.
(RTAM10)	AEDC TEST PWT-4T201 CONE-CYLINDER, N1M2C2	0.000	1.500	5.000	0.500	LREF 3.0000 INCHES
(RTAM05)	AEDC TEST PWT-4T201 CONE-CYLINDER, N1M1C1	0.000	2.250	5.000	0.400	BREF 3.0000 INCHES
						XWRP 0.0000 INCHES
						YWRP 0.0000 INCHES
						ZWRP 0.0000 INCHES
						SCALE 0.0000 NONE

EFFECT OF AFTERBODY LENGTH AND CENTERBODY

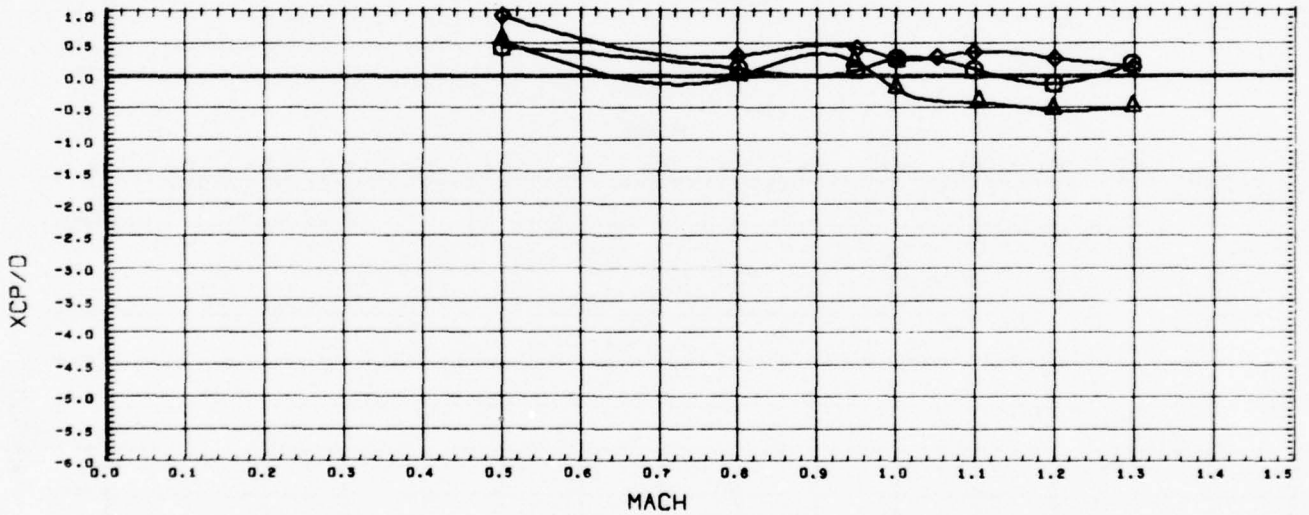
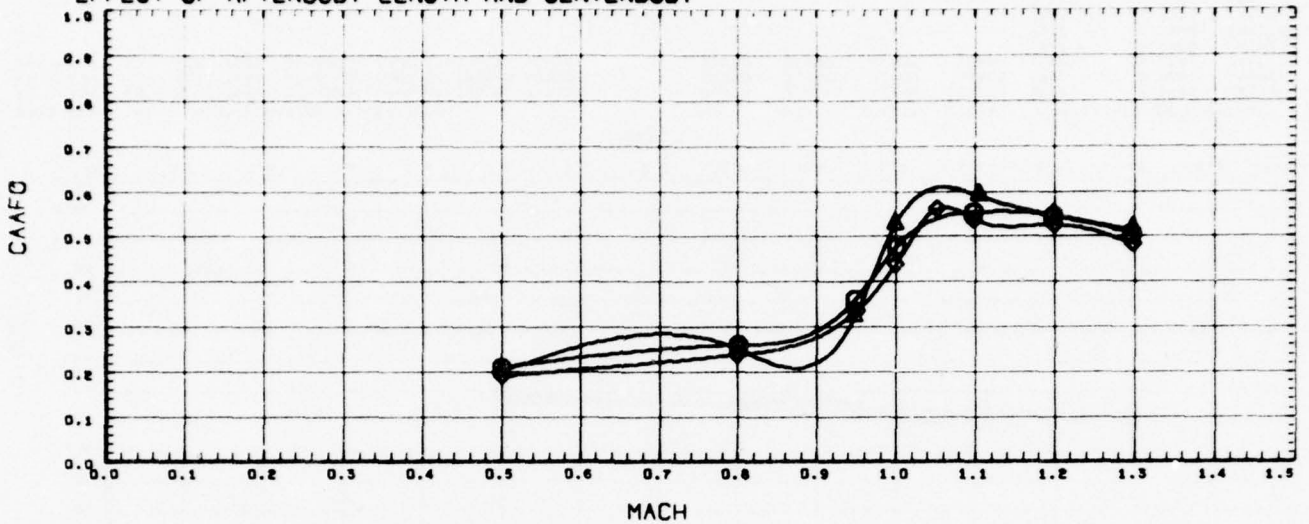

DATA SET SYMBOL	CONFIGURATION DESCRIPTION	PHI	M-LGTH	C-LGTH	C-DIA	REFERENCE INFORMATION
(BTAM13)	AEDC TEST PWT-4T201 CONE-CYLINDER, N1M1C4	0.000	2.240	6.500	0.500	SREF 7.0686 SQ. IN.
(BTAM10)	AEDC TEST PWT-4T201 CONE-CYLINDER, N1M2C2	0.000	1.500	5.000	0.500	LREF 3.0000 INCHES
(BTAM05)	AEDC TEST PWT-4T201 CONE-CYLINDER, N1M1C1	0.000	2.250	5.000	0.400	BREF 3.0000 INCHES
						XWRP 0.0000 INCHES
						YWRP 0.0000 INCHES
						ZWRP 0.0000 INCHES
						SCALE 0.0000 NONE

EFFECT OF STRUT LENGTH

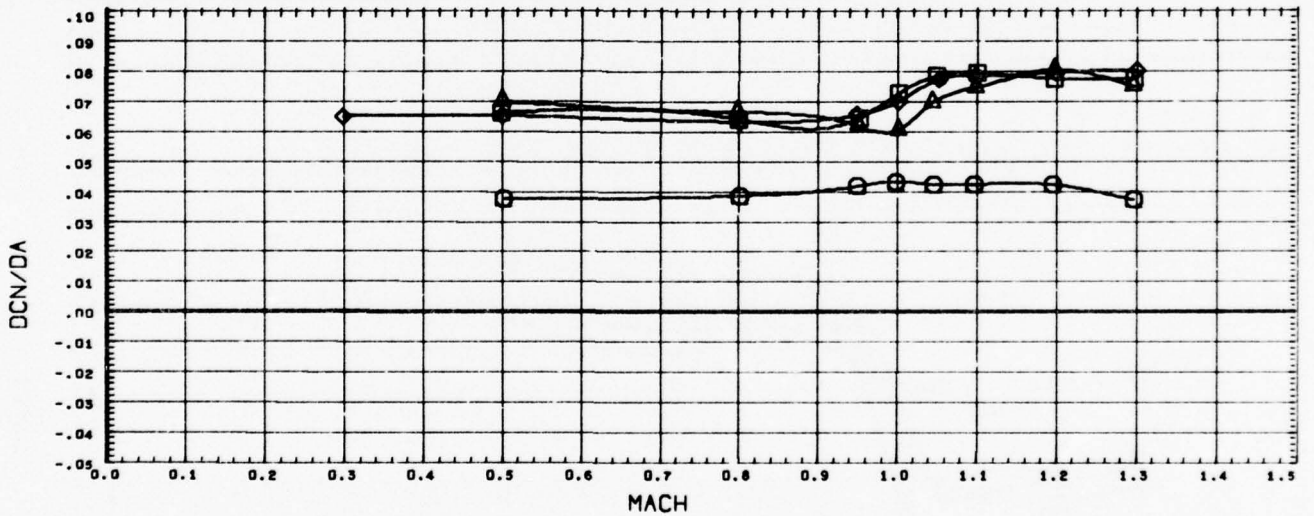
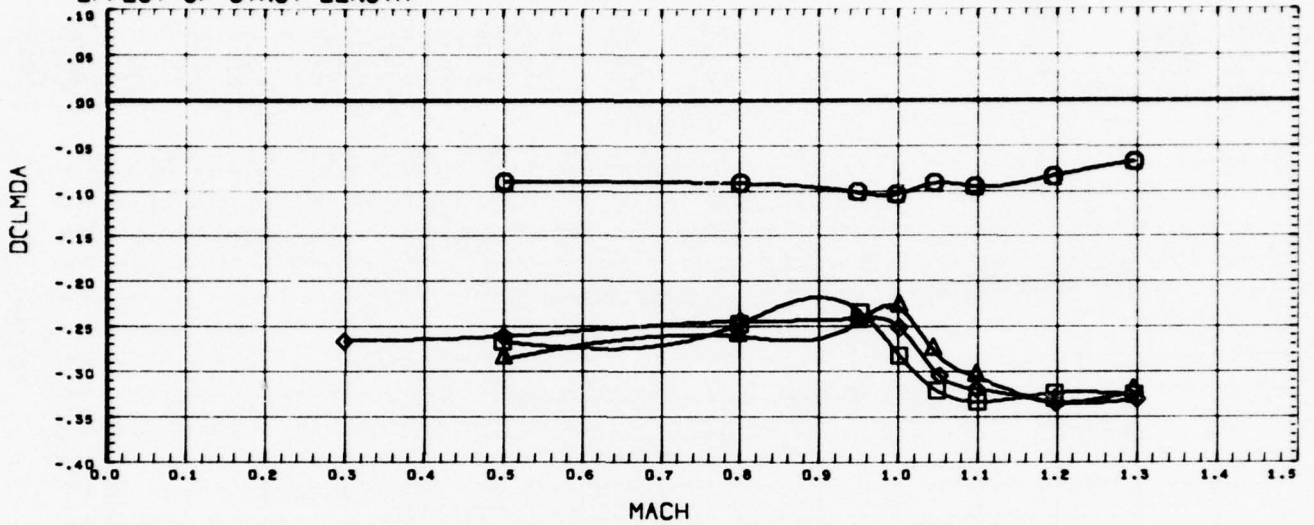

DATA SET SYMBOL	CONFIGURATION DESCRIPTION	PHI	M-LGTH	LS-LGH	REFERENCE INFORMATION
(RTAMD4)	AEDC TEST PWT-4T201 CONE-CYLINDER, N1M4	0.000	5.750		SREF 7.0686 SQ. IN.
(RTARD1)	AEDC TEST PWT-4T201 CONE-CYL. W/RING TAIL, N1R1	0.000	2.250	2.500	LREF 3.0000 INCHES
(CTARD2)	AEDC TEST PWT-4T201 CONE-CYL. W/RING TAIL, N1R2	0.000	1.500	3.250	BREF 3.0000 INCHES
(RTARD6)	AEDC TEST PWT-4T201 CONE-CYL. W/RING TAIL, N1R3	0.000	0.750	4.000	XMRP 0.0000 INCHES
					YMRP 0.0000 INCHES
					ZMRP 0.0000 INCHES
					SCALE 0.0000 NONE

EFFECT OF STRUT LENGTH

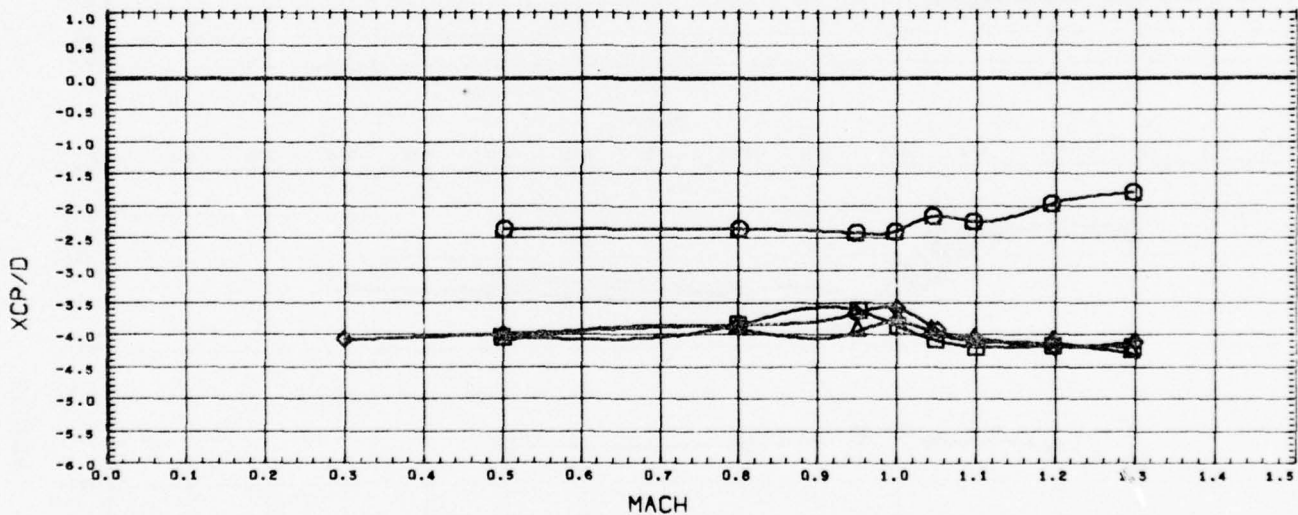
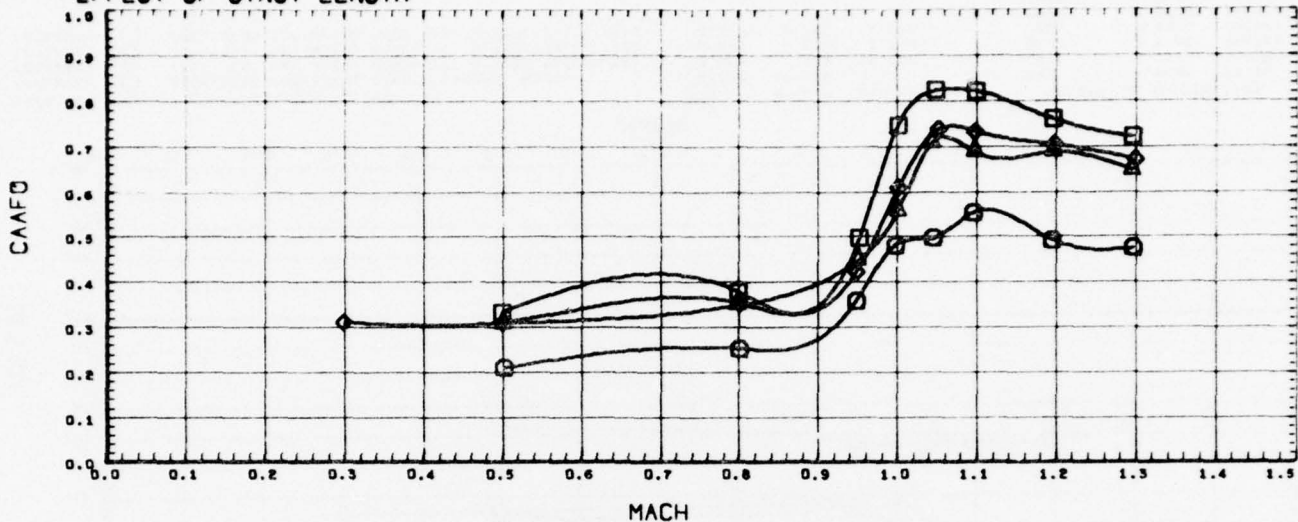

DATA SET SYMBOL	CONFIGURATION DESCRIPTION	PHI	M-LGTH	LS-LGH	REFERENCE INFORMATION
(BTAM04)	AEDC TEST PWT-4T201 CONE-CYLINDER, N1M4	0.000	5.750		SREF 7.0686 SQ. IN.
(BTAR01)	AEDC TEST PWT-4T201 CONE-CYL. W/RING TAIL, N1R1	0.000	2.250	2.500	LREF 3.0000 INCHES
(BTAR02)	AEDC TEST PWT-4T201 CONE-CYL. W/RING TAIL, N1R2	0.000	1.500	3.250	BREF 3.0000 INCHES
(BTAR06)	AEDC TEST PWT-4T201 CONE-CYL. W/RING TAIL, N1R3	0.000	0.750	4.000	YWRP 0.0000 INCHES
					ZWRP 0.0000 INCHES
					SCALE 0.0000 NONE

EFFECT OF STRUT LENGTH WITH CENTERBODY

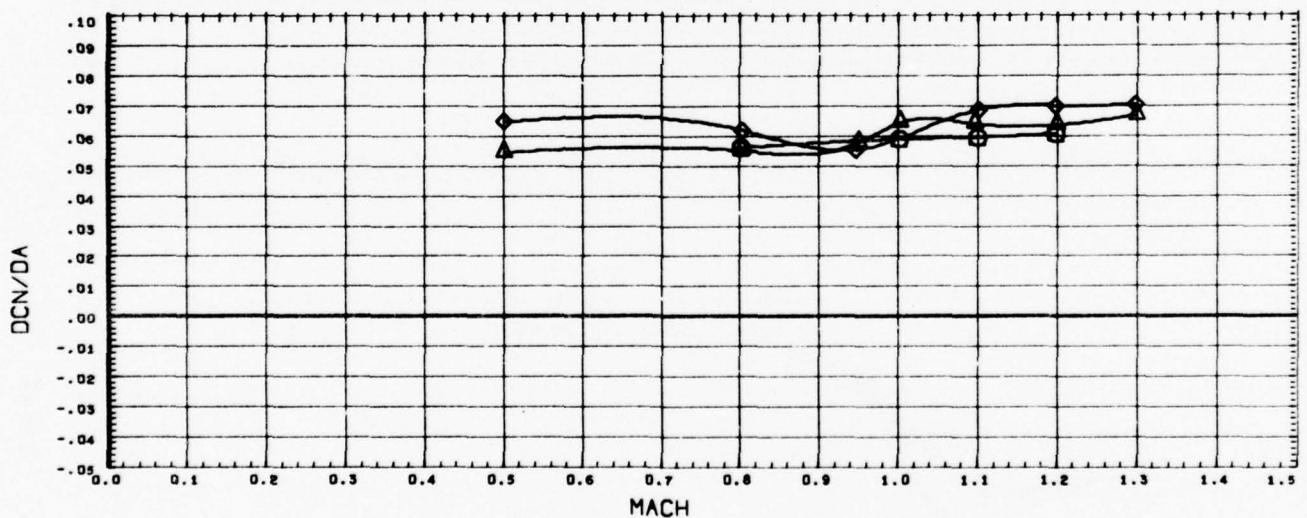
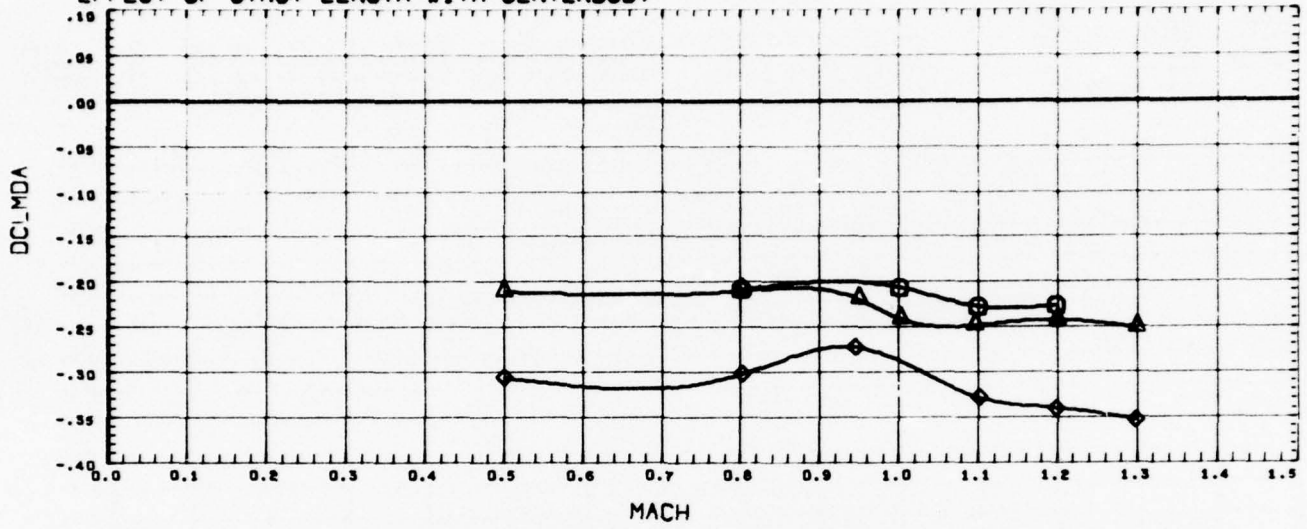

DATA SET SYMBOL	CONFIGURATION DESCRIPTION	PHI	M-LGTH	LS-LGH	REFERENCE INFORMATION
(RTAR08)	AEDC TEST PWT-4T201 CONE-CYL. W/RING TAIL,N1R1C2	0.000	2.250	2.500	SREF 7.0686 SQ. IN.
(RTAR18)	AEDC TEST PWT-4T201 CONE-CYL. W/RING TAIL,N1R2C2	0.000	1.500	3.250	LREF 3.0000 INCHES
(RTAR17)	AEDC TEST PWT-4T201 CONE-CYL. W/RING TAIL,N1R6C2	0.000	2.250	4.000	BREF 3.0000 INCHES
					XNRP 0.0000 INCHES
					YNRP 0.0000 INCHES
					ZNRP 0.0000 INCHES
					SCALE 0.0000 NONE

EFFECT OF STRUT LENGTH WITH CENTERBODY

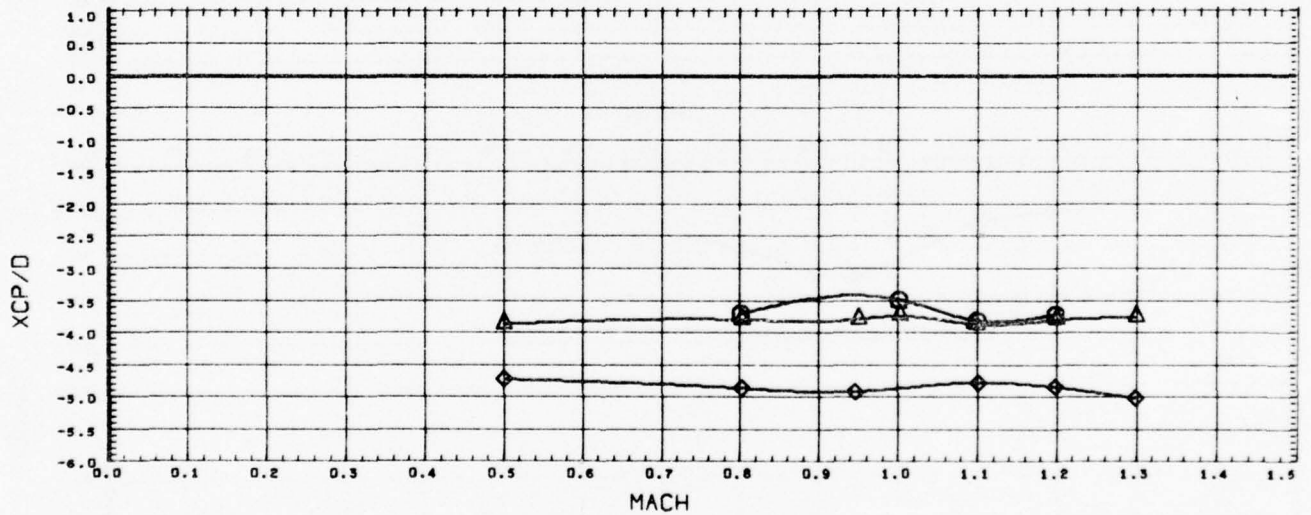
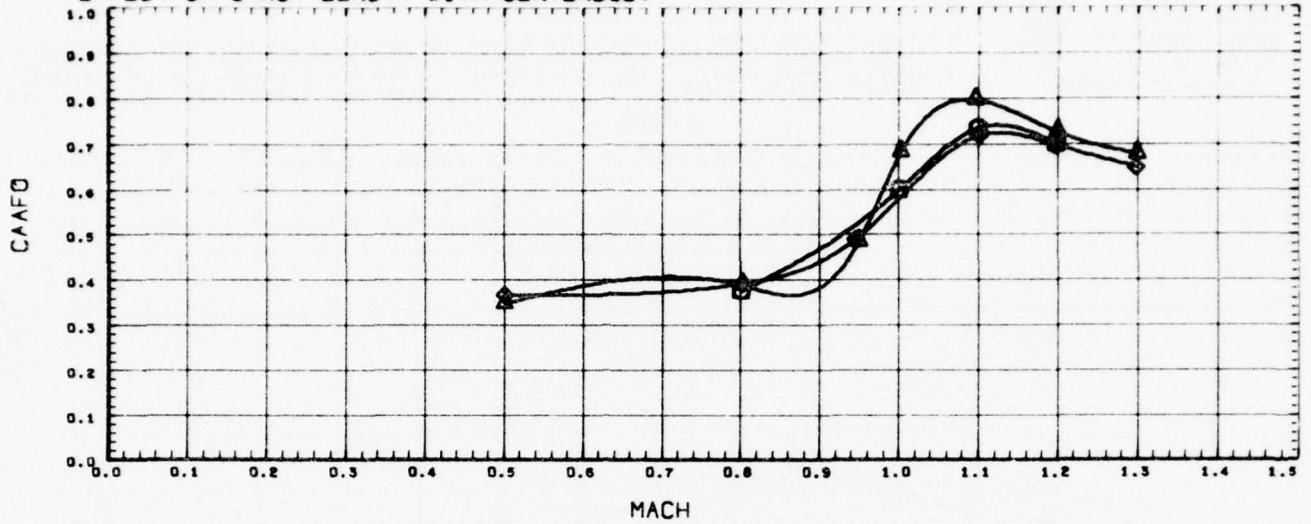

DATA SET SYMBOL	CONFIGURATION DESCRIPTION	PHI	M-LGTH	LS-LGH	REFERENCE INFORMATION
(BTAR08)	AEDC TEST PWT-4T201 CONE-CYL. W/RING TAIL,N1R1C2	0.000	2.250	2.500	SREF 7.0686 SQ. IN.
(BTAR18)	AEDC TEST PWT-4T201 CONE-CYL. W/RING TAIL,N1R2C2	0.000	1.500	3.250	LREF 3.0000 INCHES
(BTAR17)	AEDC TEST PWT-4T201 CONE-CYL. W/RING TAIL,N1R6C2	0.000	2.250	4.000	BREF 3.0000 INCHES
					YMRP 0.0000 INCHES
					ZMRP 0.0000 INCHES
					SCALE 0.0000 NONE

EFFECT OF STRUT LENGTH AND CENTERBODY DIAMETER

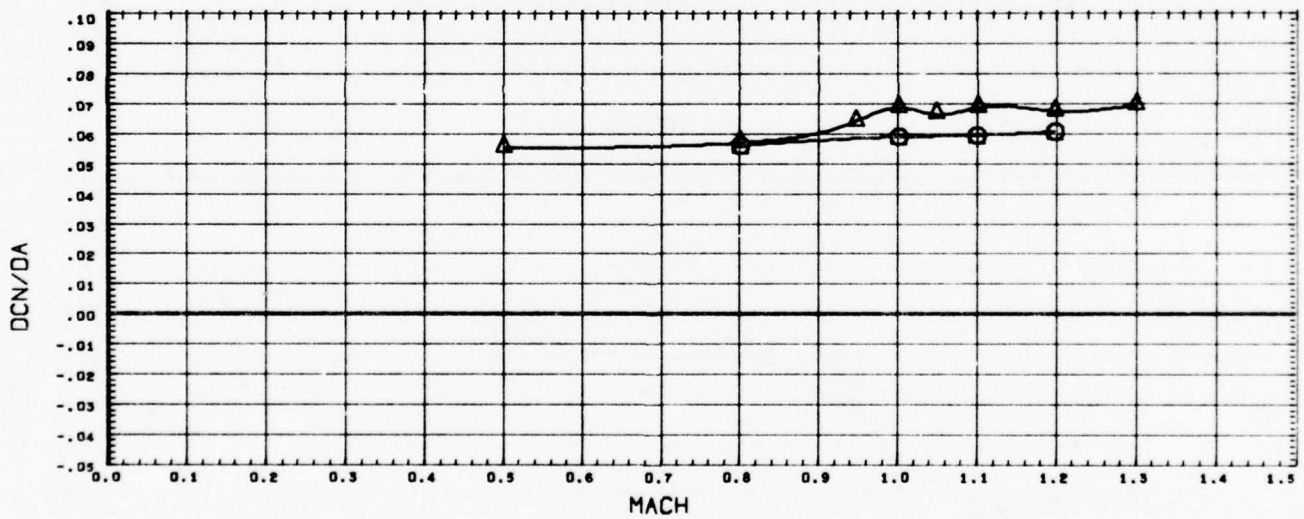
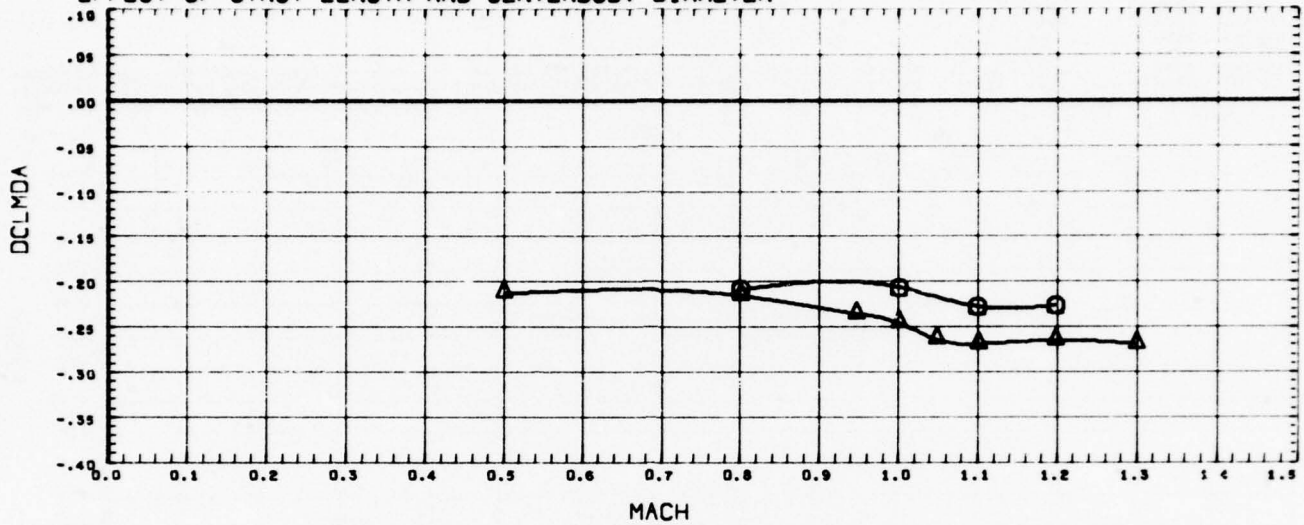

DATA SET SYMBOL	CONFIGURATION DESCRIPTION	M-LGTH	LS-LGH	C-LGTH	C-DIA	REFERENCE INFORMATION
(RTAR08)	AEDC TEST PWT-4T201 CONE-CYL. W/RING TAIL,N1R1C2	2.250	2.500	5.000	0.500	SREF 7.0606 50. IN.
(RTAR09)	AEDC TEST PWT-4T201 CONE-CYL. W/RING TAIL,N1R2C1	1.500	3.250	5.000	0.400	LREF 3.0000 INCHES BREF 3.0000 INCHES XMRP 0.0000 INCHES YMRP 0.0000 INCHES ZMRP 0.0000 INCHES SCALE 0.0000 NONE

EFFECT OF STRUT LENGTH AND CENTERBODY DIAMETER

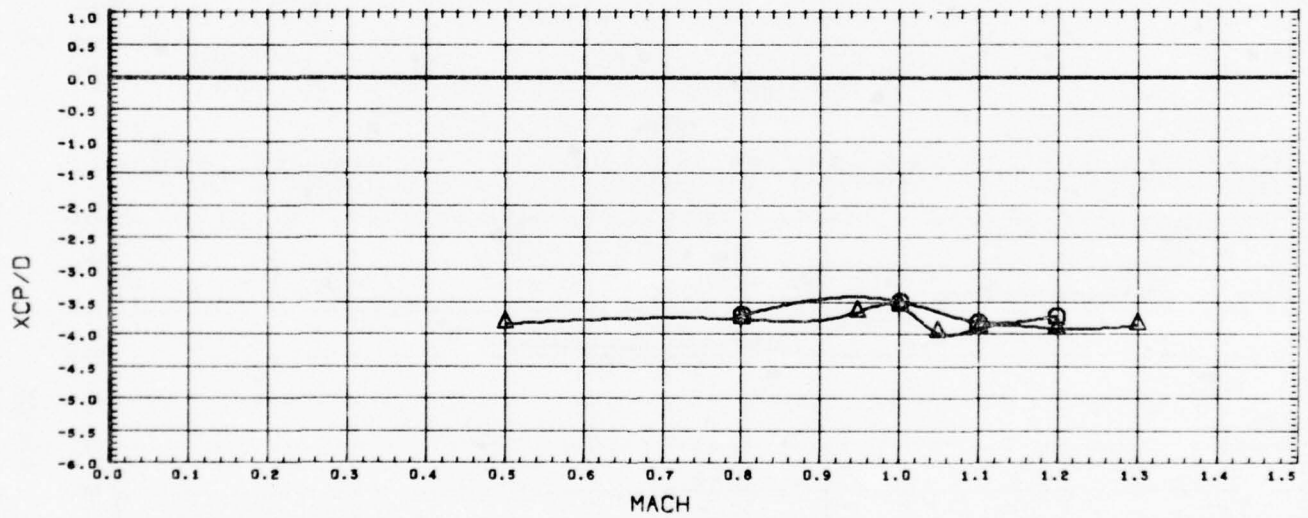
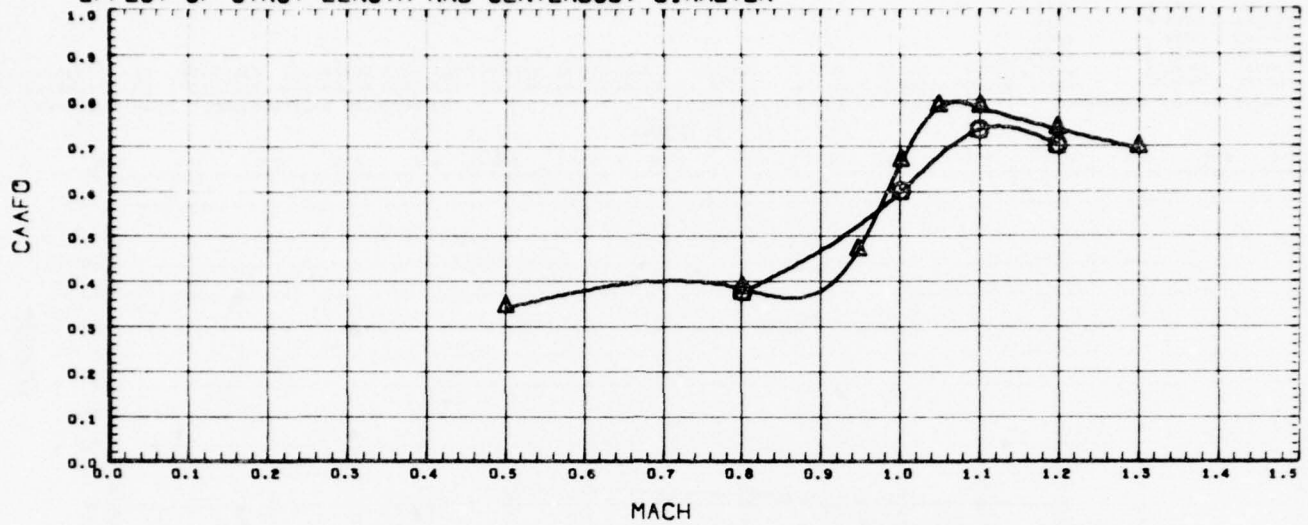

DATA SET SYMBOL	CONFIGURATION DESCRIPTION	M-LGTH	LS-LGH	C-LGTH	C-DIA	REFERENCE INFORMATION
(BTAR08)	⊙ AEDC TEST PWT-4T201 CONE-CYL. W/RING TAIL,N1R1C2	2.250	2.930	5.000	0.500	SREF 7.0586 SQ. IN. LREF 3.0000 INCHES
(BTAR09)	△ AEDC TEST PWT-4T201 CONE-CYL. W/RING TAIL,N1R2C1	1.500	3.250	5.000	0.400	BREF 3.0000 INCHES XMRP 0.0000 INCHES YMRP 0.0000 INCHES ZMRP 0.0000 INCHES SCALE 0.0000 NONE

EFFECT OF STRUT LENGTH AND CENTERBODY LENGTH

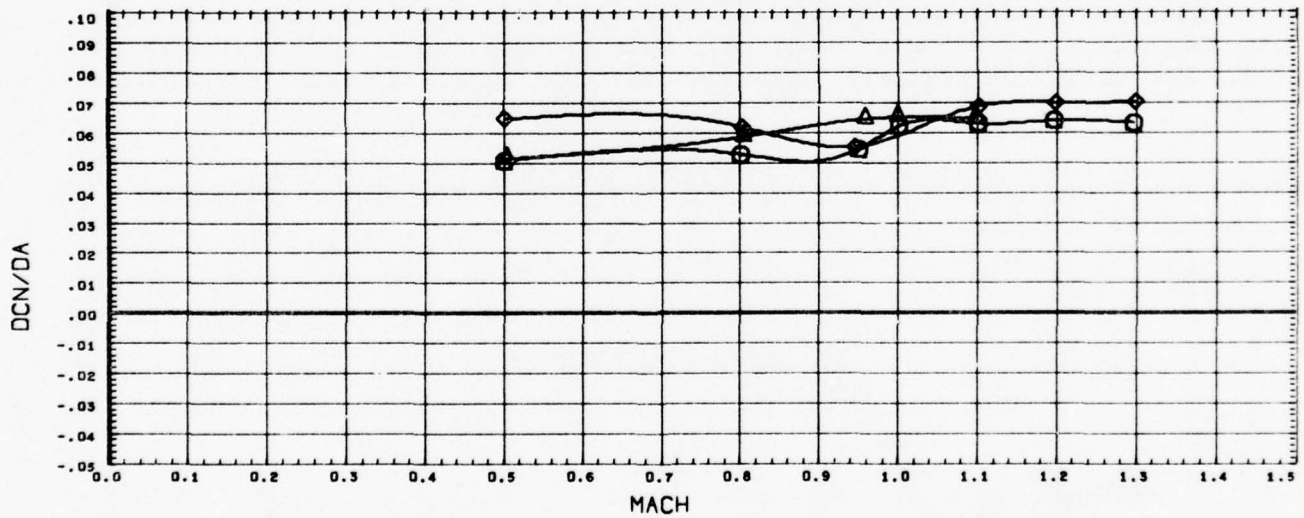
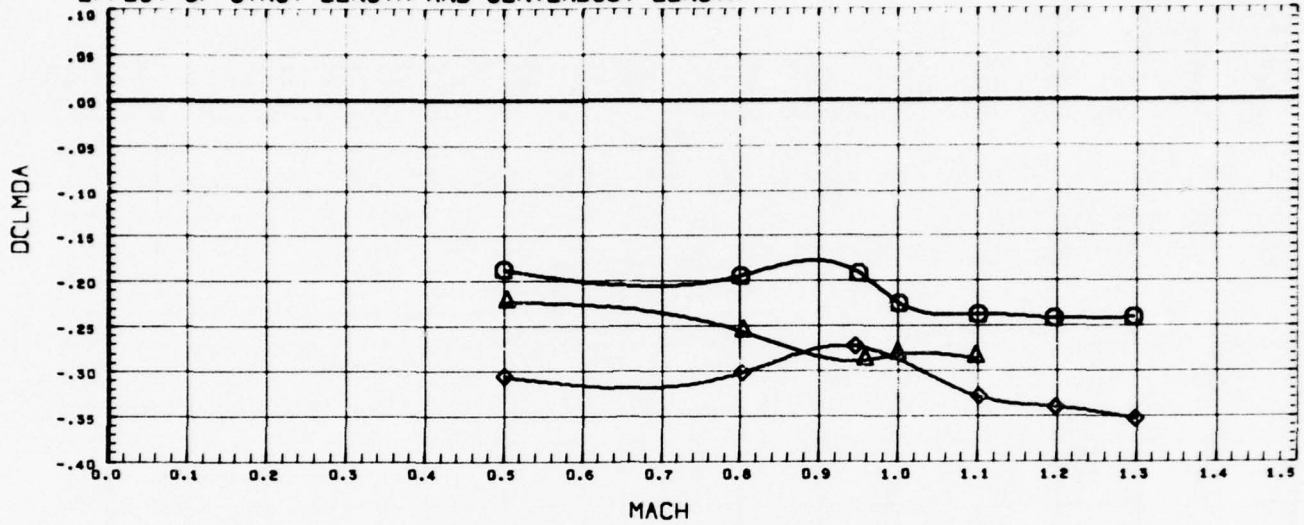

DATA SET SYMBOL	CONFIGURATION DESCRIPTION	M-LGTH	LS-LGH	C-LGTH	C-DIA	REFERENCE INFORMATION
(RTAR21)	AEDC TEST PWT-4T201 CONE-CYL. W/RING TAIL,N1R2C4	1.500	3.250	6.500	0.500	SREF 7.0686 S9. IN.
(RTAR22)	AEDC TEST PWT-4T201 CONE-CYL. W/RING TAIL,N1R6C4	2.250	4.000	6.500	0.500	LREF 3.0000 INCHES
(RTAR17)	AEDC TEST PWT-4T201 CONE-CYL. W/RING TAIL,N1R6C2	2.250	4.000	5.000	0.500	BREF 3.0000 INCHES XWRP 0.0000 INCHES YWRP 0.0000 INCHES ZWRP 0.0000 INCHES SCALE 0.0000 NONE

EFFECT OF STRUT LENGTH AND CENTERBODY LENGTH

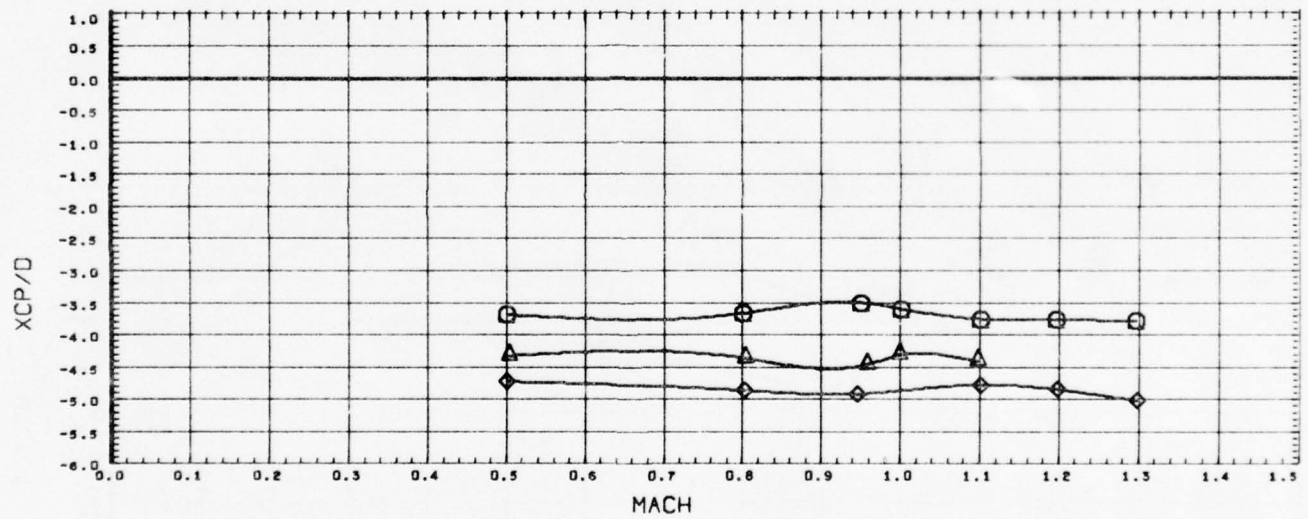
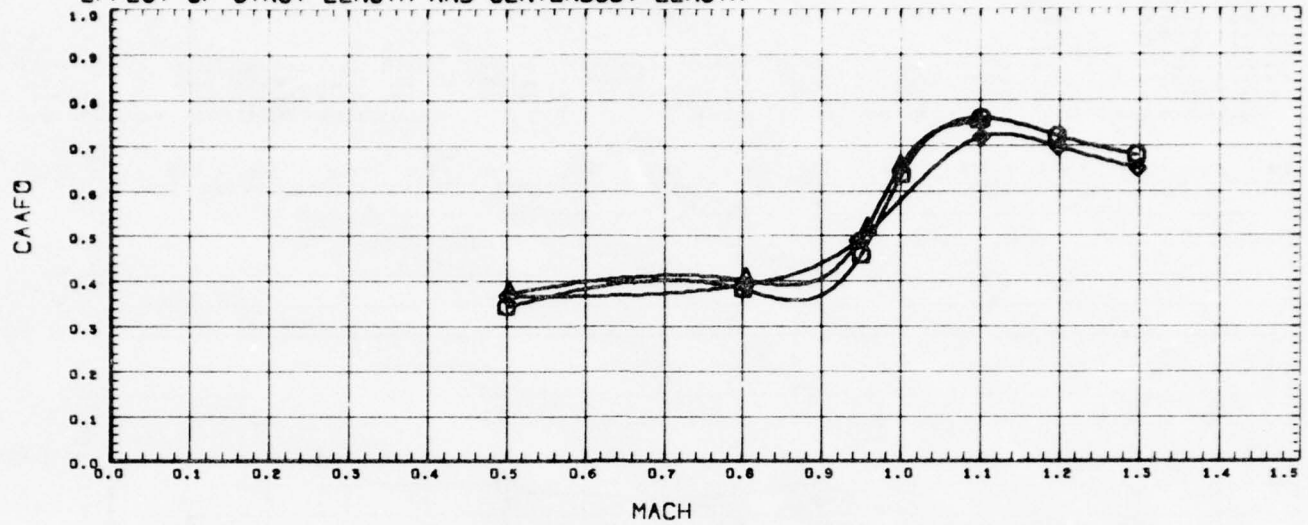

DATA SET SYMBOL	CONFIGURATION DESCRIPTION	M-LGTH	LS-LGH	C-LGTH	C-DIA	REFERENCE INFORMATION
(BTAR21)	AEDC TEST PWT-4T201 CONE-CYL. W/RING TAIL,N1R2C4	1.500	3.250	6.500	0.500	SREF 7.0686 50. IN.
(BTAR22)	AEDC TEST PWT-4T201 CONE-CYL. W/RING TAIL,N1R6C4	2.250	4.000	6.500	0.500	LREF 3.0000 INCHES
(BTAR17)	AEDC TEST PWT-4T201 CONE-CYL. W/RING TAIL,N1R6C2	2.250	4.000	5.000	0.500	BREF 3.0000 INCHES XMRP 0.0000 INCHES YMRP 0.0000 INCHES ZMRP 0.0000 INCHES SCALE 0.0000 NONE

EFFECT OF STRUT WIDTH

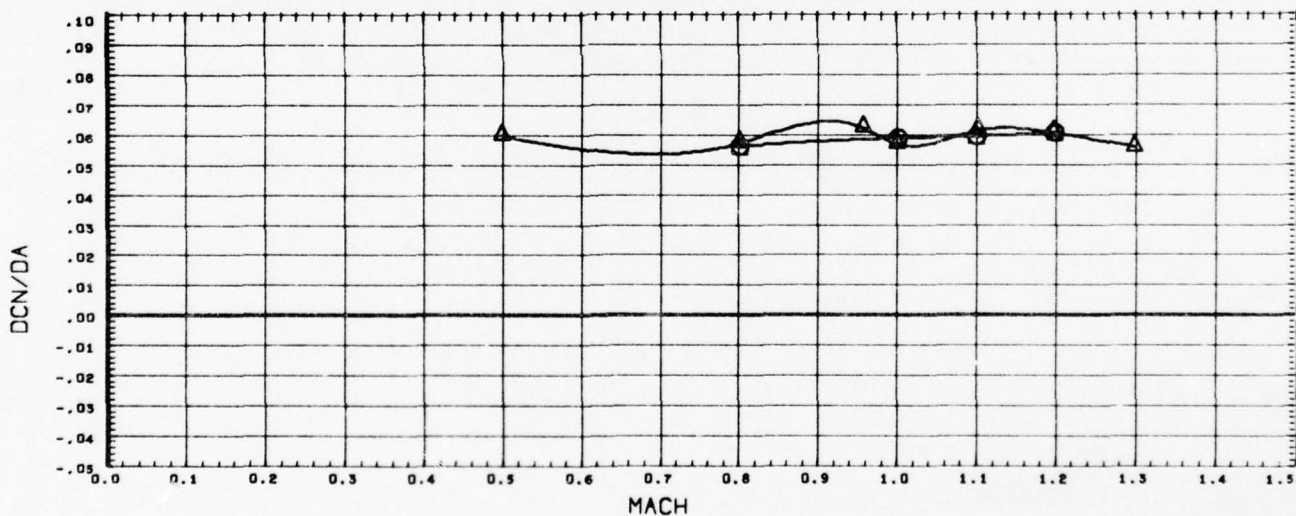
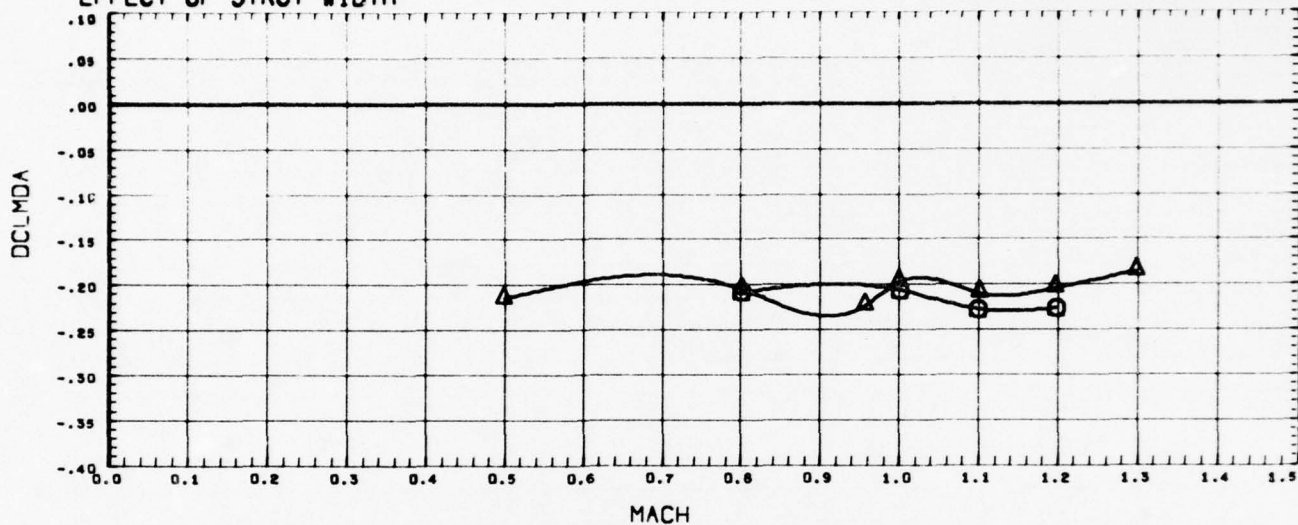

DATA SET SYMBOL	CONFIGURATION DESCRIPTION	M-LGTH	S-WDTH	C-LGTH	C-DIA	REFERENCE INFORMATION	
(RTAR08)	AEDC TEST PWT-4T201 CONE-CYL. W/RING TAIL,N1R1C2	2.250	0.230	5.000	0.500	SREF	7.0686 SQ. IN.
(RTAR14)	AEDC TEST PWT-4T201 CONE-CYL. W/RING TAIL,N1R5C1	2.250	0.400	5.000	0.400	LREF	3.0000 INCHES
						BREF	3.0000 INCHES
						XMRP	0.0000 INCHES
						YMRP	0.0000 INCHES
						ZMRP	0.0000 INCHES
						SCALE	0.0000 NONE

EFFECT OF STRUT WIDTH

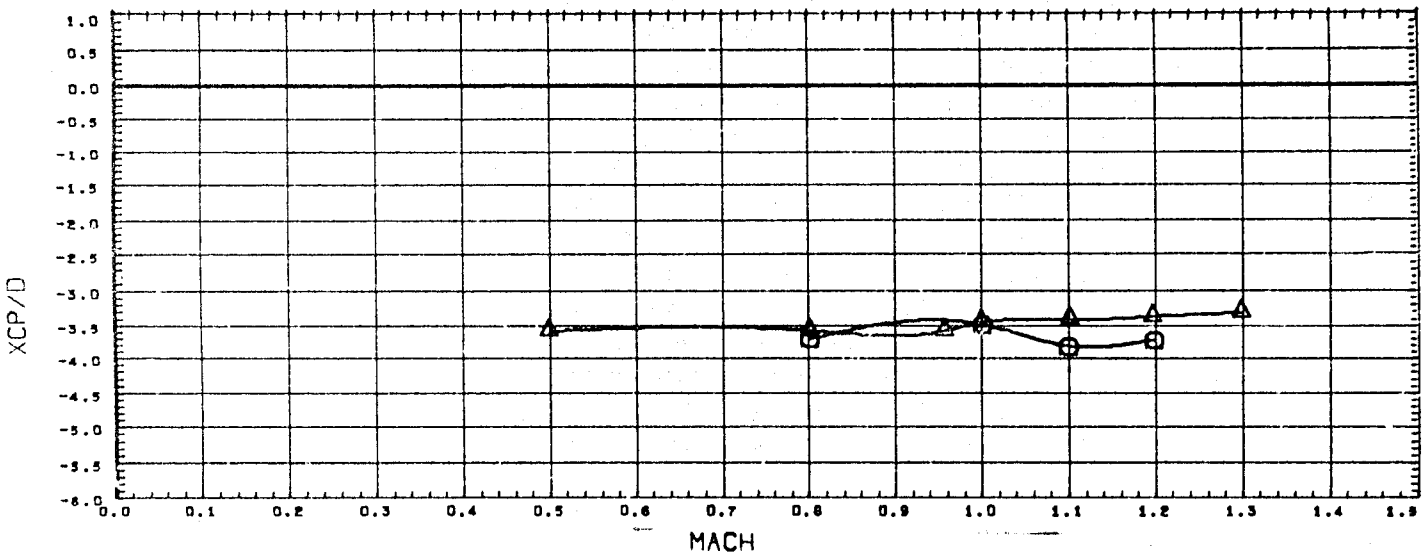
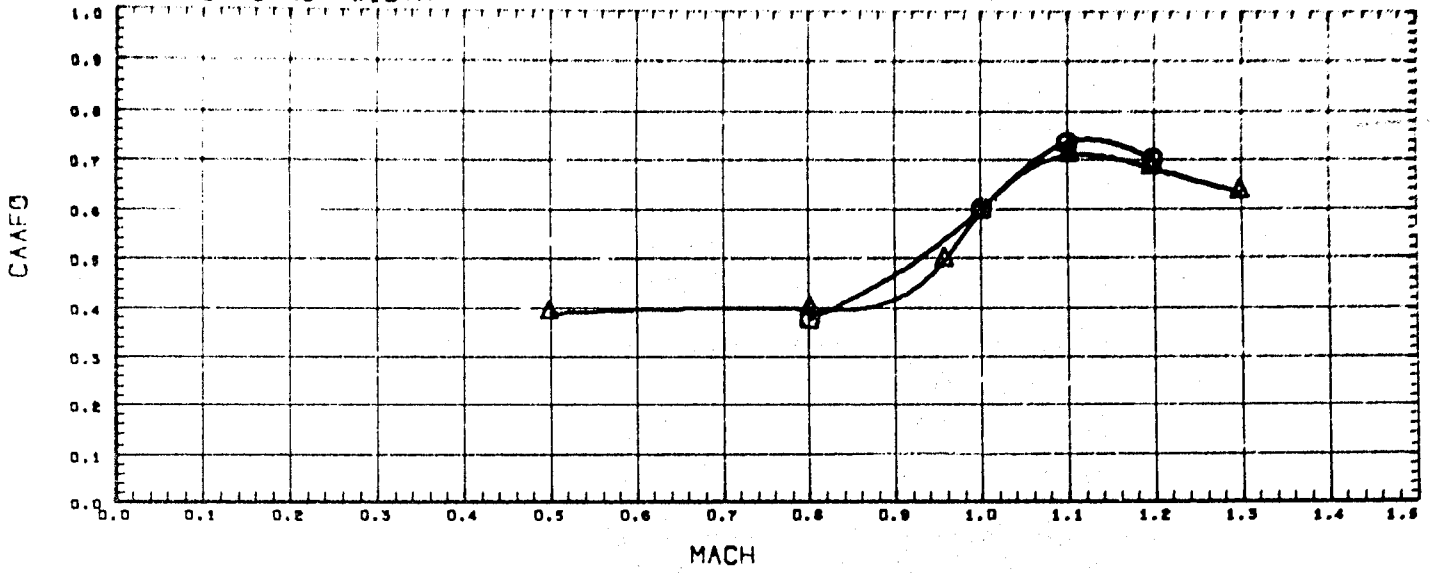

DATA SET SYMBOL	CONFIGURATION DESCRIPTION	M-LGTH	S-WDTH	C-LGTH	C-DIA	REFERENCE INFORMATION	
(BTAR08)	AEDC TEST PWT-4T201 CONE-CYL. W/RING TAIL,N1R1C2	2.250	0.200	5.000	0.500	SREF	7.0666 SQ. IN.
(BTAR14)	AEDC TEST PWT-4T201 CONE-CYL. W/RING TAIL,N1R5C1	2.250	0.400	5.000	0.400	LREF	3.0000 INCHES
						BREF	3.0000 INCHES
						XMRP	0.0000 INCHES
						YMRP	0.0000 INCHES
						ZMRP	0.0000 INCHES
						SCALE	0.0000 NONE

LOADS ON CENTERBODY (WITH RING)

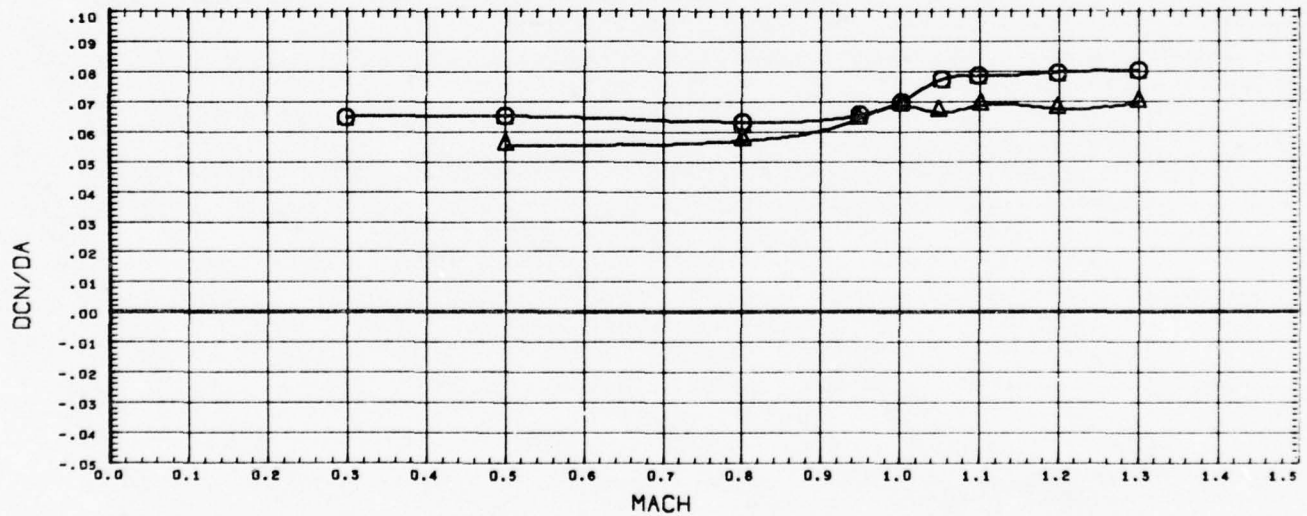
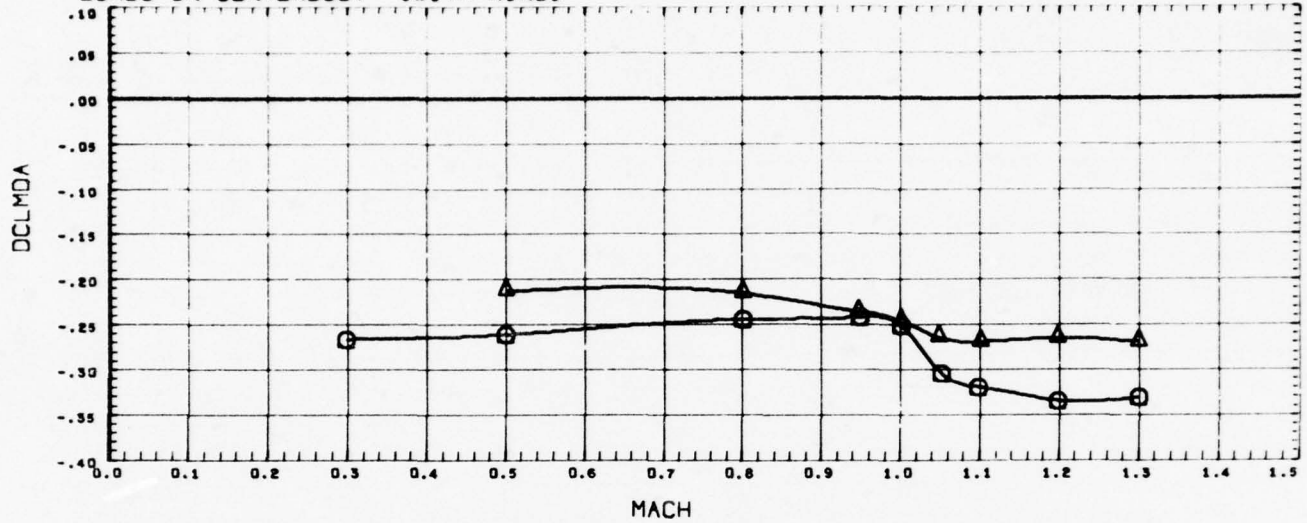

DATA SET SYMBOL	CONFIGURATION DESCRIPTION	M-LGTH	LS-LGH	C-LGTH	C-DIA	REFERENCE INFORMATION
(CTARD2)	⊙ AEDC TEST PWT-4T201 CONE-CYL. W/RING TAIL, N1R2	1.500	3.250			SREF 7.0686 SQ. IN.
(RTARD9)	△ AEDC TEST PWT-4T201 CONE-CYL. W/RING TAIL, N1R2C1	1.500	3.250	5.000	0.400	LREF 3.0000 INCHES
						BREF 3.0000 INCHES
						XWRP 0.0000 INCHES
						YWRP 0.0000 INCHES
						ZWRP 0.0000 INCHES
						SCALE 0.0000 NONE

LOADS ON CENTERBODY (WITH RING)

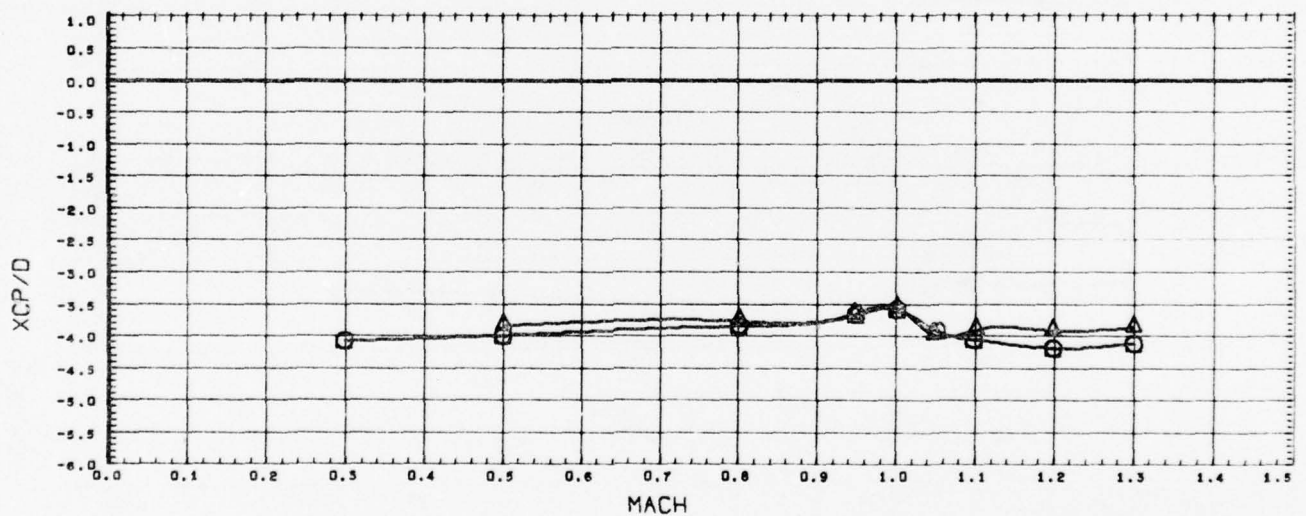
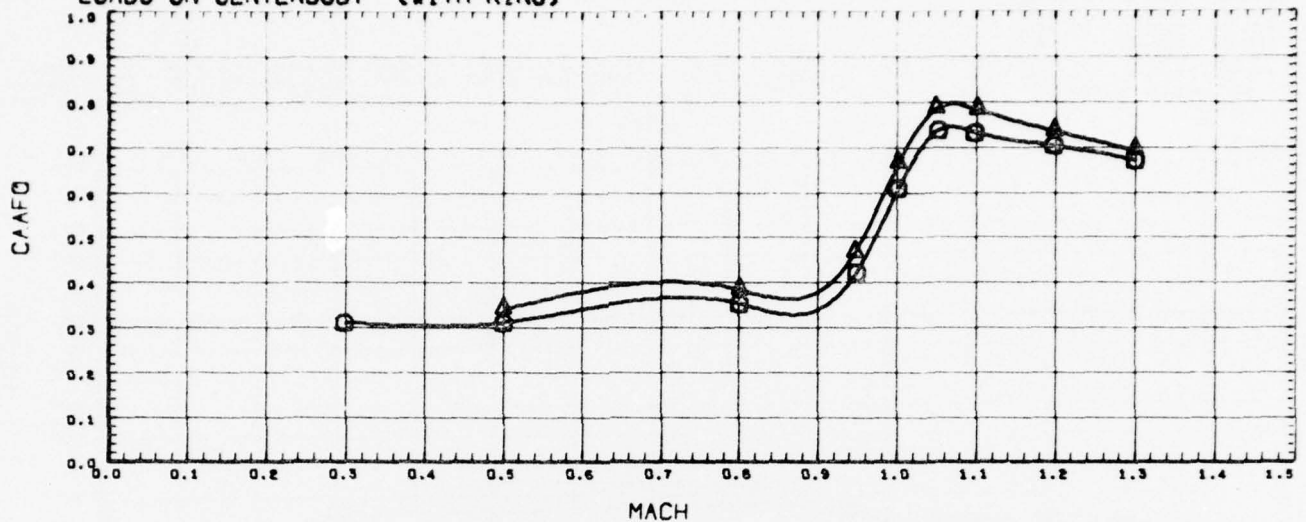

DATA SET SYMBOL	CONFIGURATION DESCRIPTION	M-LGTH	LS-LGM	C-LGTH	C-DIA	REFERENCE INFORMATION
(BTARD2)	AEDC TEST PWT-4T201 CONE-CYL. W/RING TAIL, N1R2	1.500	3.250			SREF 7.0686 SQ. IN.
(BTARD9)	AEDC TEST PWT-4T201 CONE-CYL. W/RING TAIL, N1R2C1	1.500	3.250	5.000	0.400	LREF 3.0000 INCHES
						BREF 3.0000 INCHES
						XMRP 0.0000 INCHES
						YMRP 0.0000 INCHES
						ZMRP 0.0000 INCHES
						SCALE 0.0000 NONE

EFFECT OF ASPECT RATIO

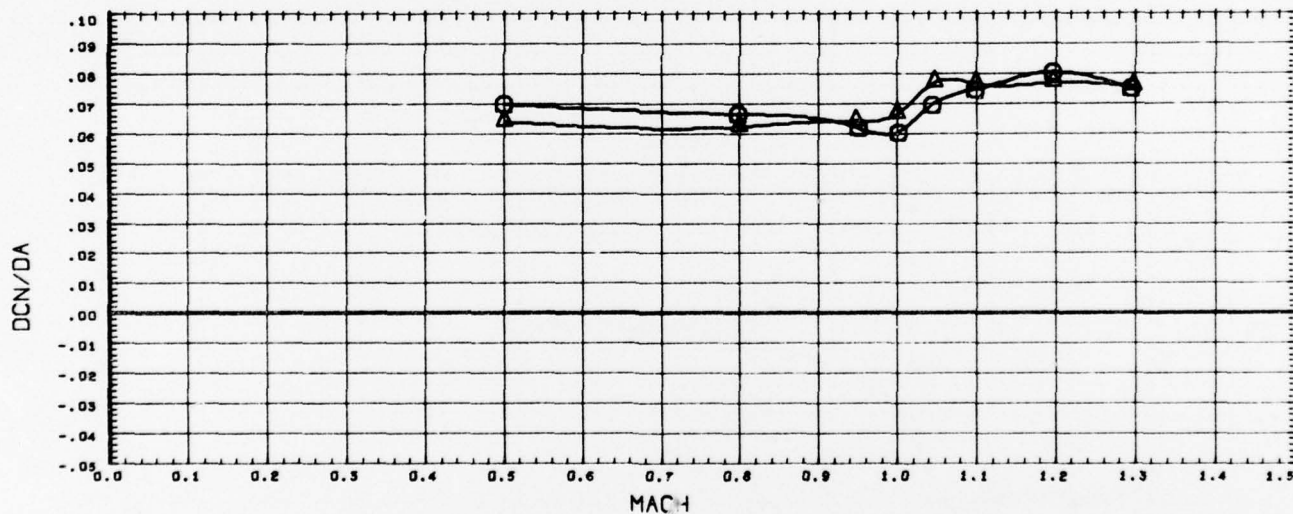
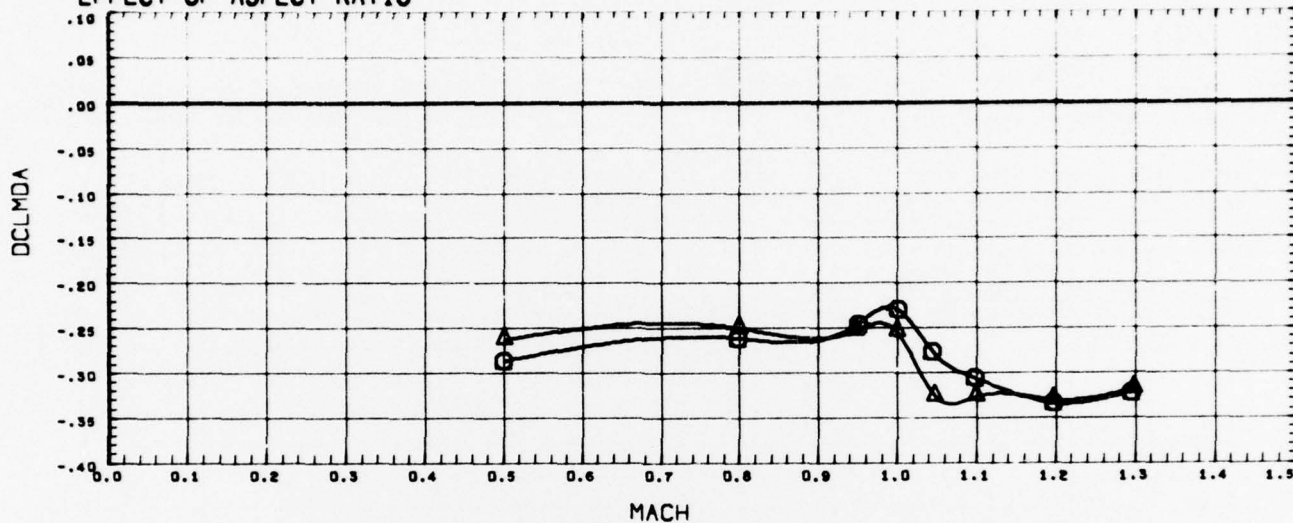

DATA SET SYMBOL	CONFIGURATION DESCRIPTION	M-LGTH	LS-LGH	S-WDTH	R-WDTH	REFERENCE INFORMATION
(RTARD1)	⊗ AEDC TEST PWT-4T201 CONE-CYL. W/RING TAIL, N1R1	2.250	2.590	0.200	1.000	SREF 7.0686 SQ. IN. LREF 3.0000 INCHES
(RTARD7)	⊙ AEDC TEST PWT-4T201 CONE-CYL. W/RING TAIL, N1R4	2.250	3.000	0.200	1.000	BREF 3.0000 INCHES XMRP 0.0000 INCHES YMRP 0.0000 INCHES ZMRP 0.0000 INCHES SCALE 0.0000 NONE

EFFECT OF ASPECT RATIO

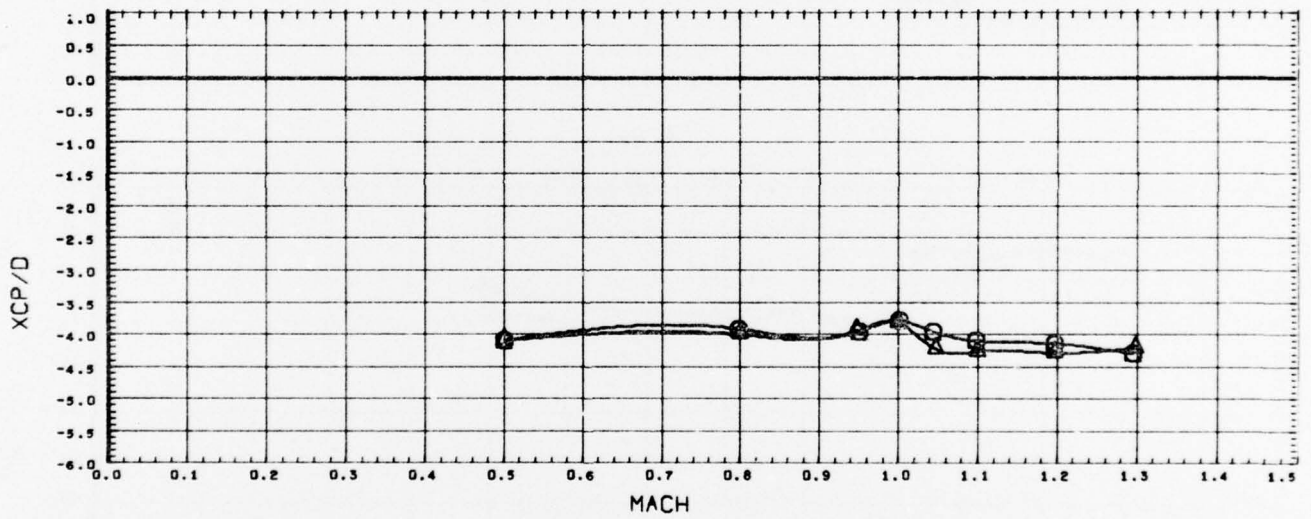
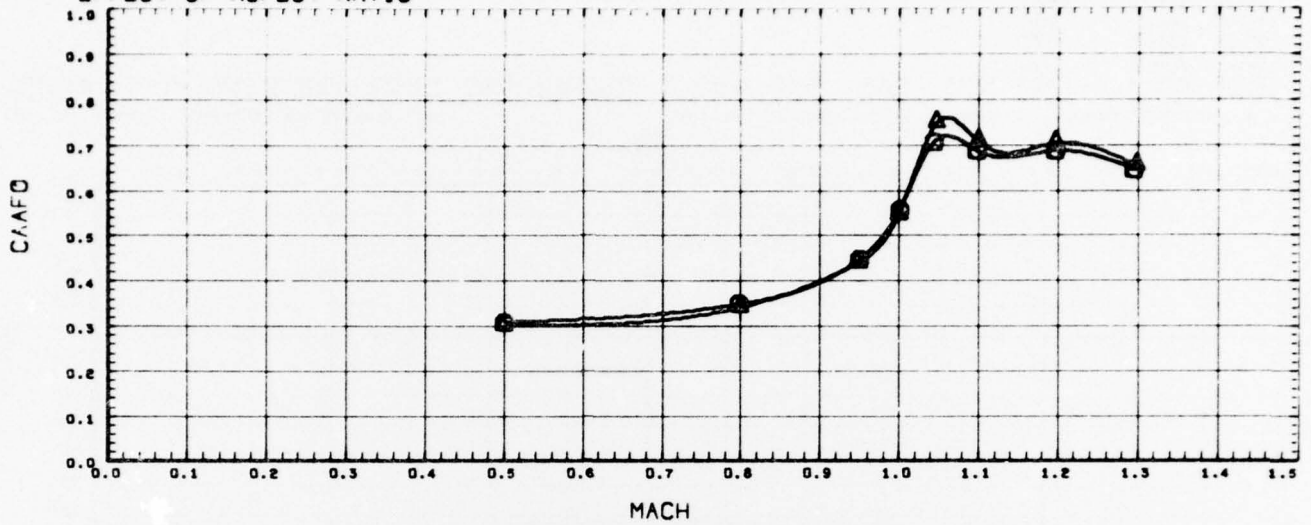

DATA SET SYMBOL	CONFIGURATION DESCRIPTION	M-LGTH	LS-LGH	S-WDTH	R-WDTH	REFERENCE INFORMATION	
(BTARD1)	⊙ AEDC TEST PWT-4T201 CONE-CYL. W/RING TAIL, N1R1	2.250	2.400	0.200	1.000	SREF	7.0686 SQ. IN.
(BTARD7)	△ AEDC TEST PWT-4T201 CONE-CYL. W/RING TAIL, N1R4	2.250	3.000	0.200	1.000	LREF	3.0000 INCHES
						BREF	3.0000 INCHES
						YMRP	0.0000 INCHES
						ZMRP	0.0000 INCHES
						SCALE	0.0000 NONE

EFFECT OF ASPECT RATIO AND CENTERBODY DIAMETER

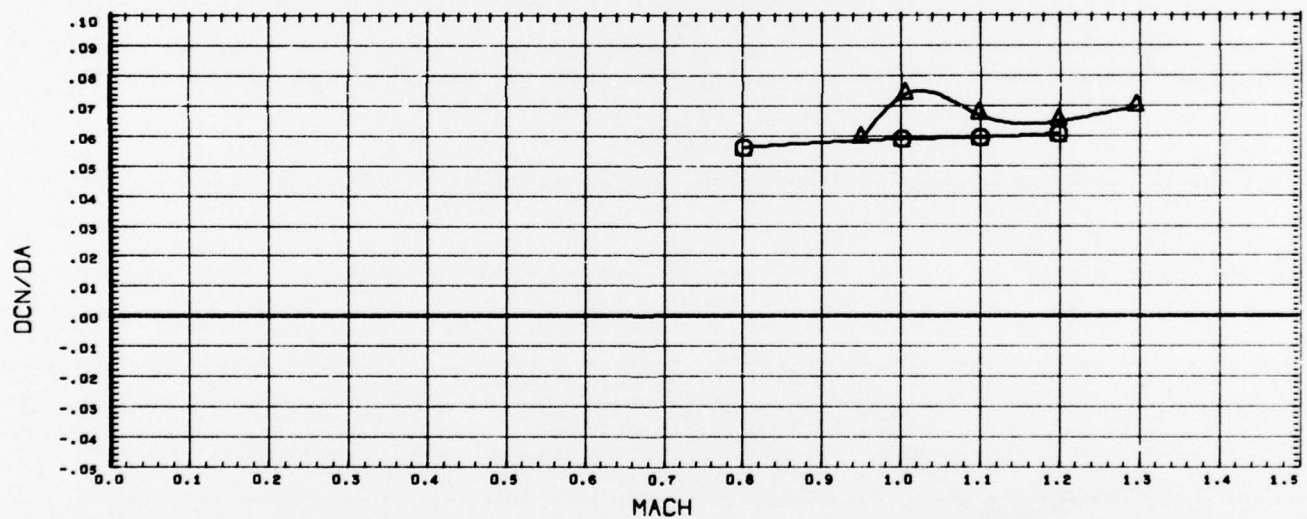
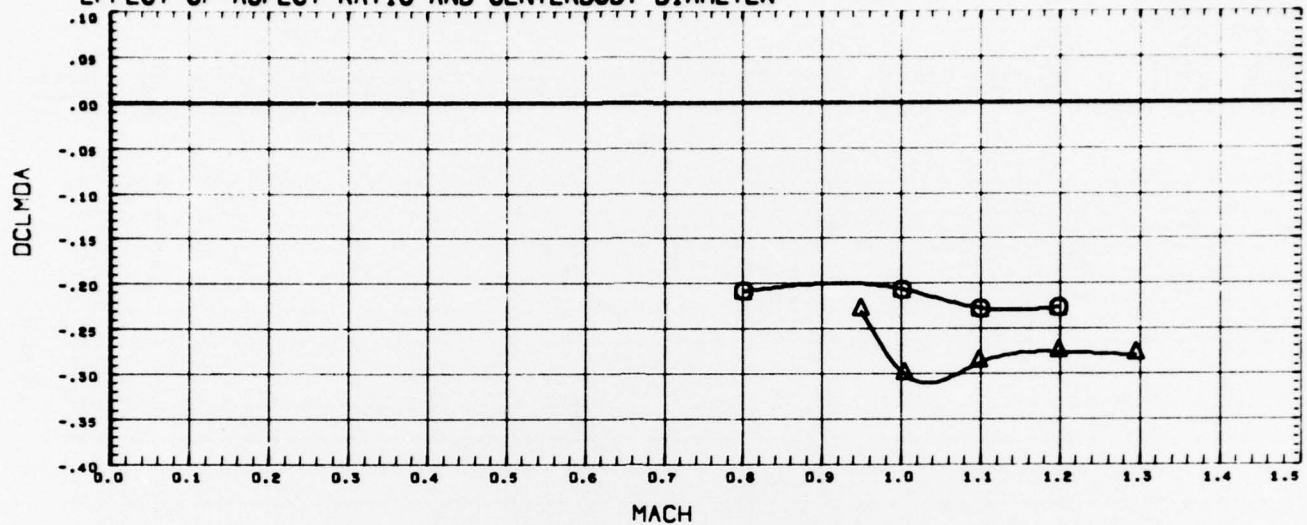

DATA SET SYMBOL	CONFIGURATION DESCRIPTION	PHI	M-LGTH	C-LGTH	C-DIA	REFERENCE INFORMATION
(RTAR08) \odot	AEDC TEST PWT-4T201 CONE-CYL. W/RING TAIL,N1R1C2	0.000	2.250	5.000	0.500	SREF 7.0686 SQ. IN. LREF 3.0000 INCHES BREF 3.0000 INCHES
(RTAR13) \triangle	AEDC TEST PWT-4T201 CONE-CYL. W/RING TAIL,N1R4C1	0.000	2.250	5.000	0.400	YMRP 0.0000 INCHES YMRP 0.0000 INCHES ZMRP 0.0000 INCHES SCALE 0.0000 NONE

EFFECT OF ASPECT RATIO AND CENTERBODY DIAMETER

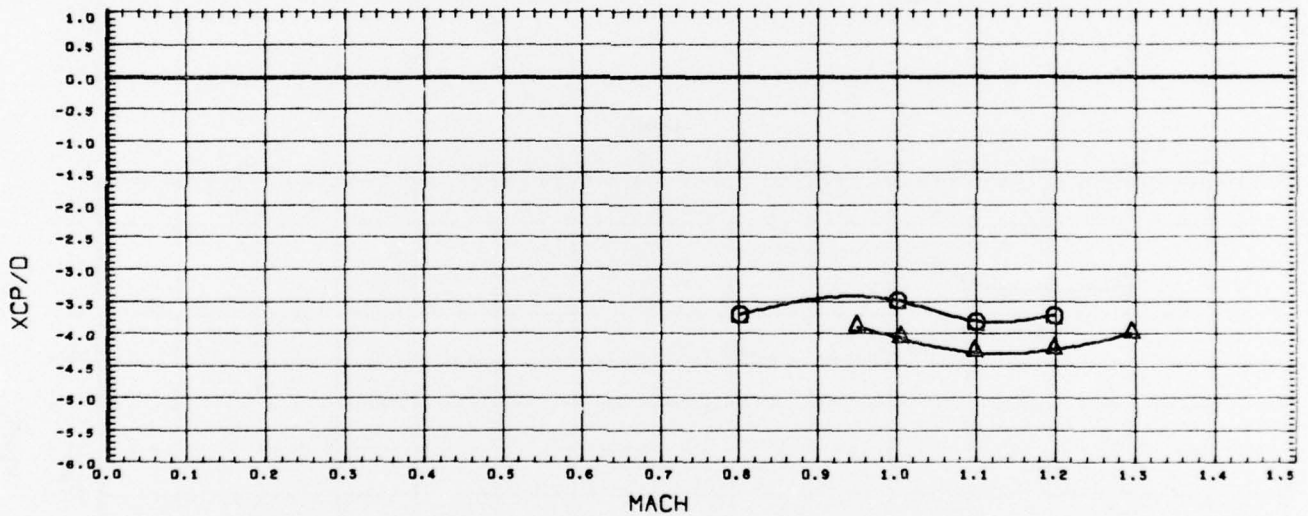
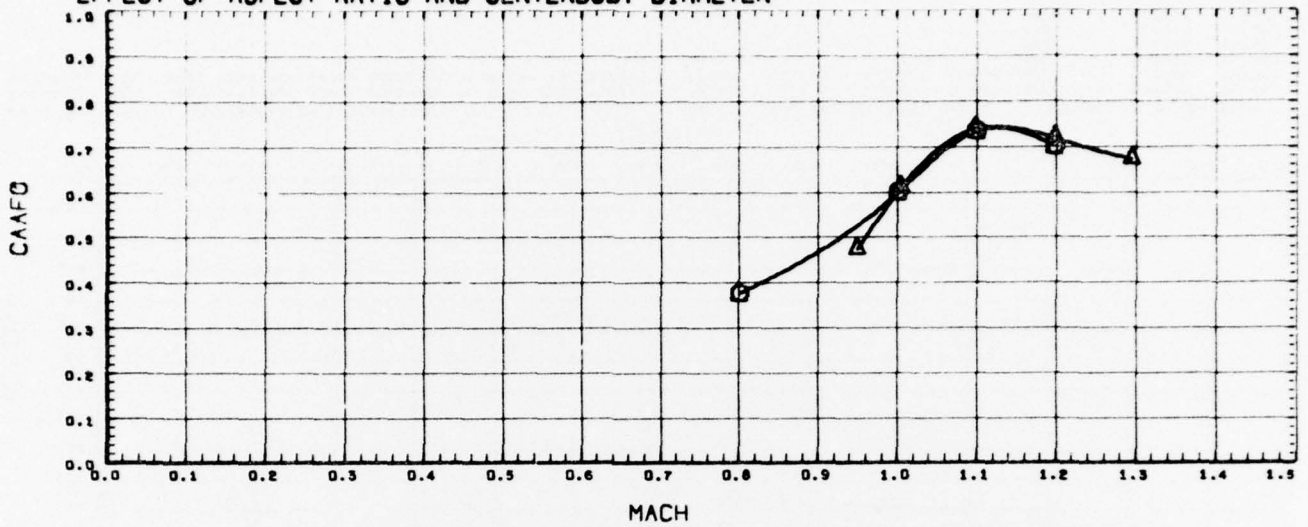

DATA SET SYMBOL	CONFIGURATION DESCRIPTION	PHI	M-LGTH	C-LGTH	C-DIA	REFERENCE INFORMATION
(BTAR08)	AEDC TEST PWT-4T201 CONE-CYL. W/RING TAIL;N1R1C2	0.000	2.250	5.000	0.500	SREF 7.0686 SQ.IN.
(BTAR13)	AEDC TEST PWT-4T201 CONE-CYL. W/RING TAIL;N1R4C1	0.000	2.250	5.000	0.400	LREF 3.0000 INCHES BREF 3.0000 INCHES XMRP 0.0000 INCHES YMRP 0.0000 INCHES ZMRP 0.0000 INCHES SCALE 0.0000 NONE

EFFECT OF BOATTAIL

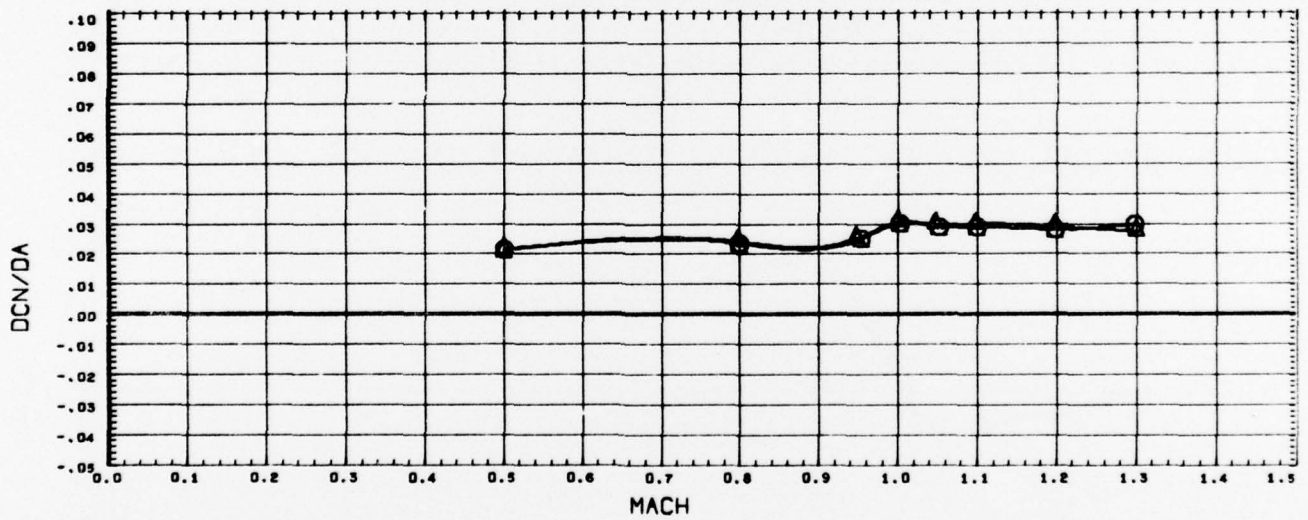
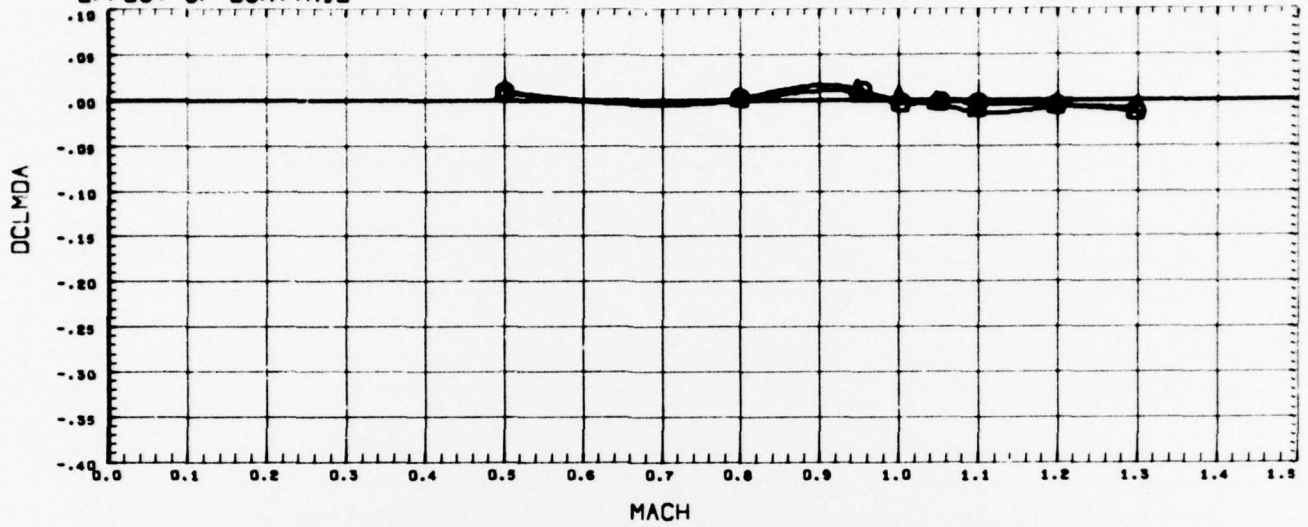

DATA SET SYMBOL	CONFIGURATION DESCRIPTION	M-LGTH	LS-LGH	C-LGTH	C-DIA	REFERENCE INFORMATION	
(CYAM06)	AEDC TEST PWT-4T201 CONE-CYLINDER, N1M2C1	1.500		5.000	0.400	SREF	7.0686 SQ. IN.
(RTAM08)	AEDC TEST PWT-4T201 CONE-CYLINDER, N1M2B1C1	1.500		5.000	0.400	LREF	3.0000 INCHES
						BREF	3.0000 INCHES
						XMRP	0.0000 INCHES
						YMRP	0.0000 INCHES
						ZMRP	0.0000 INCHES
						SCALE	0.0000 NONE

EFFECT OF BOATTAIL

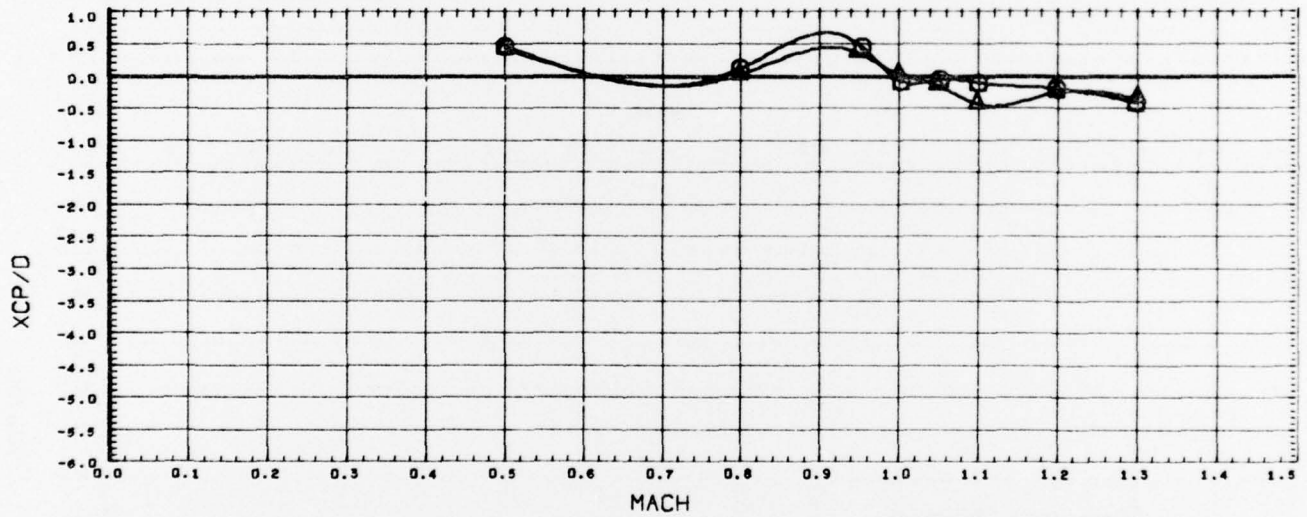
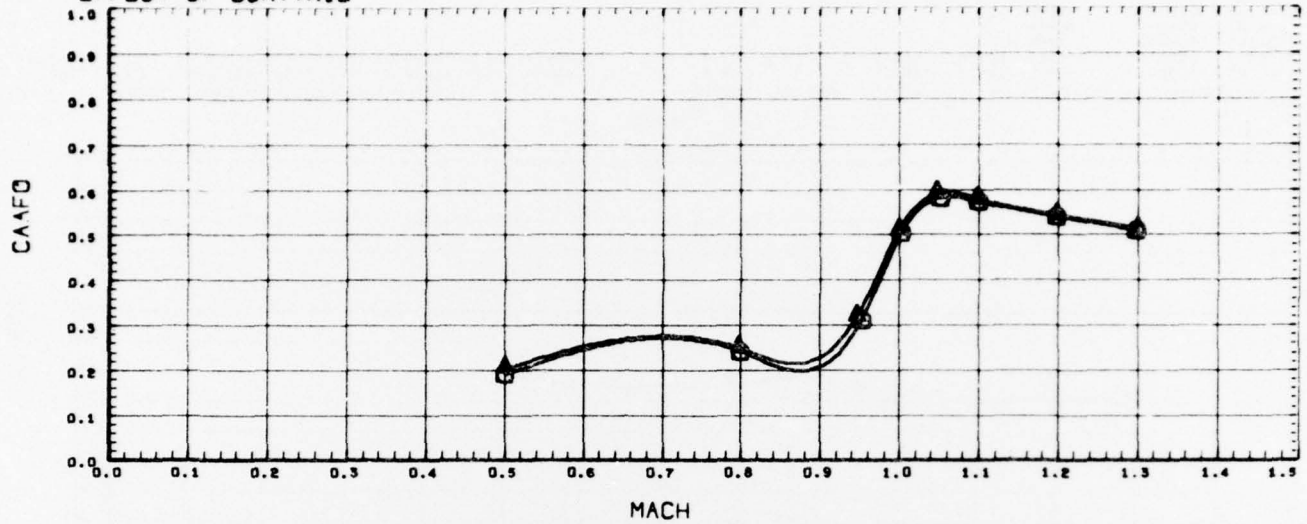

DATA SET SYMBOL	CONFIGURATION DESCRIPTION	M-LGTH	LS-LGH	C-LGTH	C-DIA	REFERENCE INFORMATION
(BTAN06)	AEDC TEST PWT-4T201 CONE-CYLINDER, N1M2C1	1.500		5.000	0.400	SREF 7.0686 SQ. IN.
(BTAN08)	AEDC TEST PWT-4T201 CONE-CYLINDER, N1M2B1C1	1.500		5.000	0.400	LREF 3.0000 INCHES
						BREF 3.0000 INCHES
						XMRP 0.0000 INCHES
						YMRP 0.0000 INCHES
						ZMRP 0.0000 INCHES
						SCALE 0.0000 NONE

EFFECT OF MODEL ROLL ANGLE

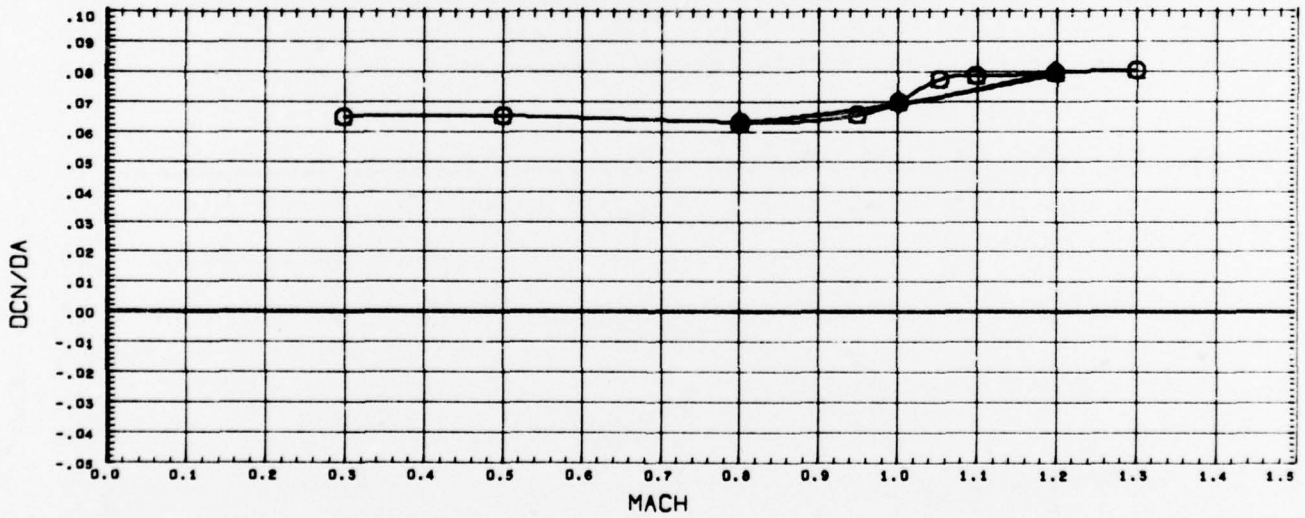
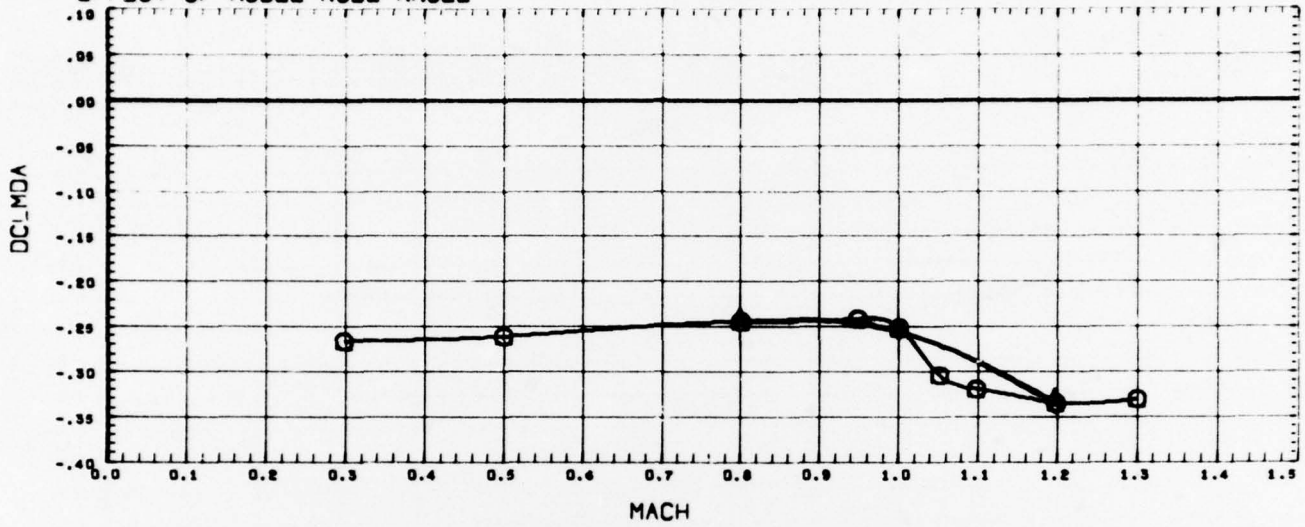

DATA SET SYMBOL	CONFIGURATION DESCRIPTION	PHI	M-LGTH	LS-LGH	REFERENCE INFORMATION
(CTAR02)	AEDC TEST PWT-4T201 CONE-CYL. W/RING TAIL, N1R2	0.000	1.500	3.250	SREF 7.0686 50. IN.
(RTAR03)	AEDC TEST PWT-4T201 CONE-CYL. W/RING TAIL, N1R2	22.500	1.500	3.250	LREF 3.0000 INCHES
(RTAR04)	AEDC TEST PWT-4T201 CONE-CYL. W/RING TAIL, N1R2	45.000	1.500	3.250	BREF 3.0000 INCHES
					XMRP 0.0000 INCHES
					YMRP 0.0000 INCHES
					ZMRP 0.0000 INCHES
					SCALE 0.0000 NONE

EFFECT OF MODEL ROLL ANGLE

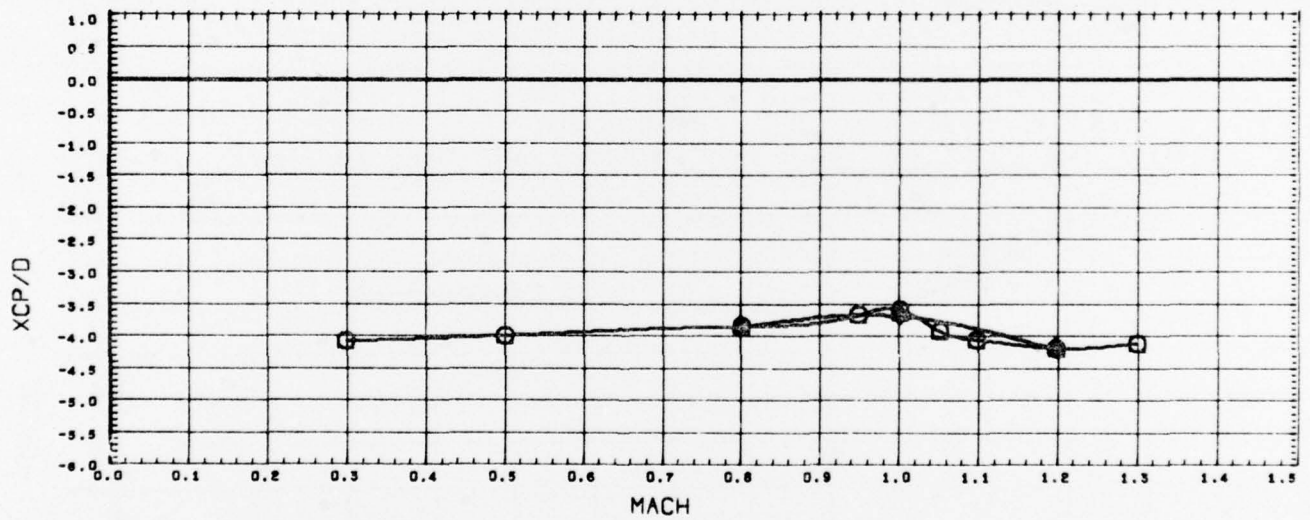
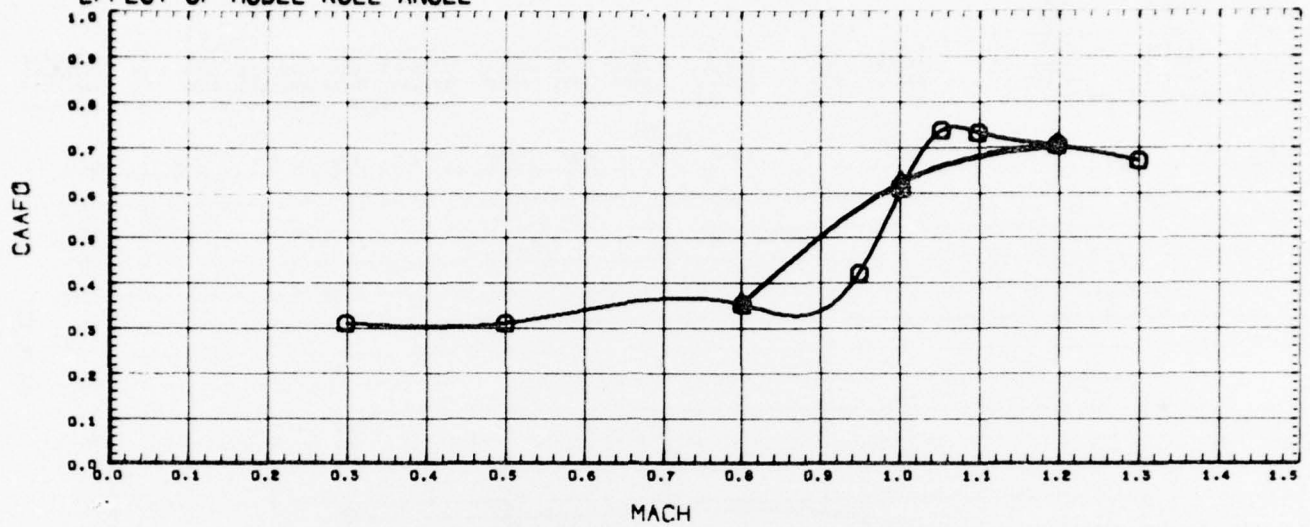

DATA SET SYMBOL	CONFIGURATION DESCRIPTION	PHI	M-LGTH	LS-LGH	REFERENCE INFORMATION
(BTARD2)	AEDC TEST PWT-4T201 CONE-CYL. W/RING TAIL, N1R2	0.000	1.500	3.250	SREF 7.0686 SQ. IN.
(BTARD3)	AEDC TEST PWT-4T201 CONE-CYL. W/RING TAIL, N1R2	22.500	1.500	3.250	LREF 3.0000 INCHES
(BTARD4)	AEDC TEST PWT-4T201 CONE-CYL. W/RING TAIL, N1R2	45.000	1.500	3.250	BREF 3.0000 INCHES
					XMRP 0.0000 INCHES
					YMRP 0.0000 INCHES
					ZMRP 0.0000 INCHES
					SCALE 0.0000 NONE

EFFECT OF MODEL ROLL ANGLE

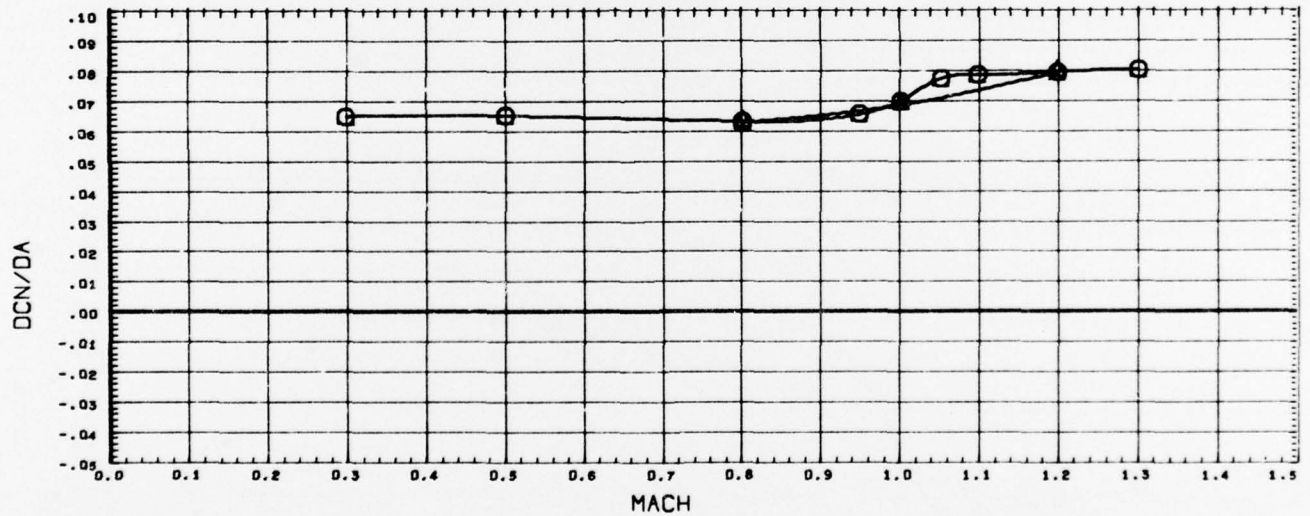
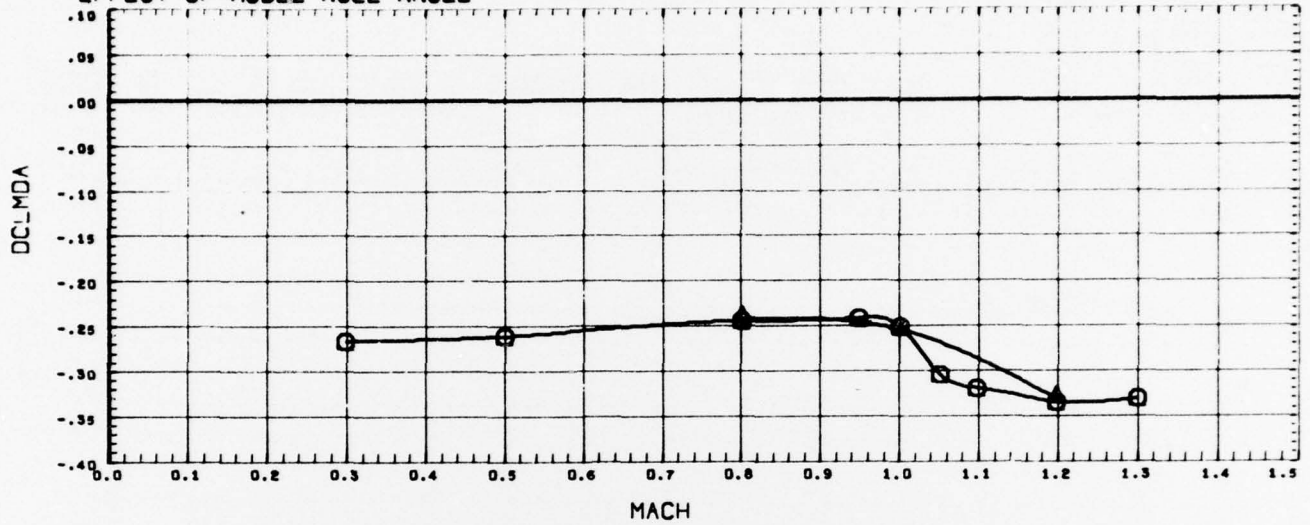

DATA SET SYMBOL	CONFIGURATION DESCRIPTION	PHI	M-LGTH	LS-LGH	REFERENCE INFORMATION
(CTARD2)	⊙ AEDC TEST PWT-4T201 CONE-CYL. W/RING TAIL, N1R2	0.000	1.200	3.250	SREF 7.0686 SQ. IN.
(RTARD5)	⊙ AEDC TEST PWT-4T201 CONE-CYL. W/RING TAIL, N1R2	180.000	1.500	3.250	LREF 3.0000 INCHES
					BREF 3.0000 INCHES
					XMRP 0.0000 INCHES
					YMRP 0.0000 INCHES
					ZMRP 0.0000 INCHES
					SCALE 0.0000 NONE

EFFECT OF MODEL ROLL ANGLE

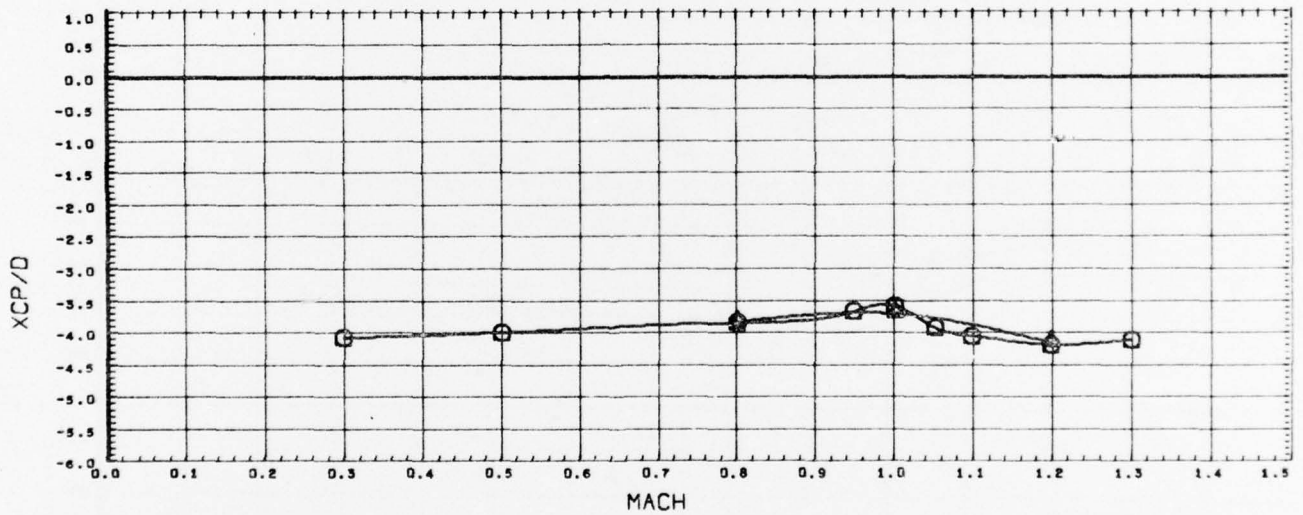
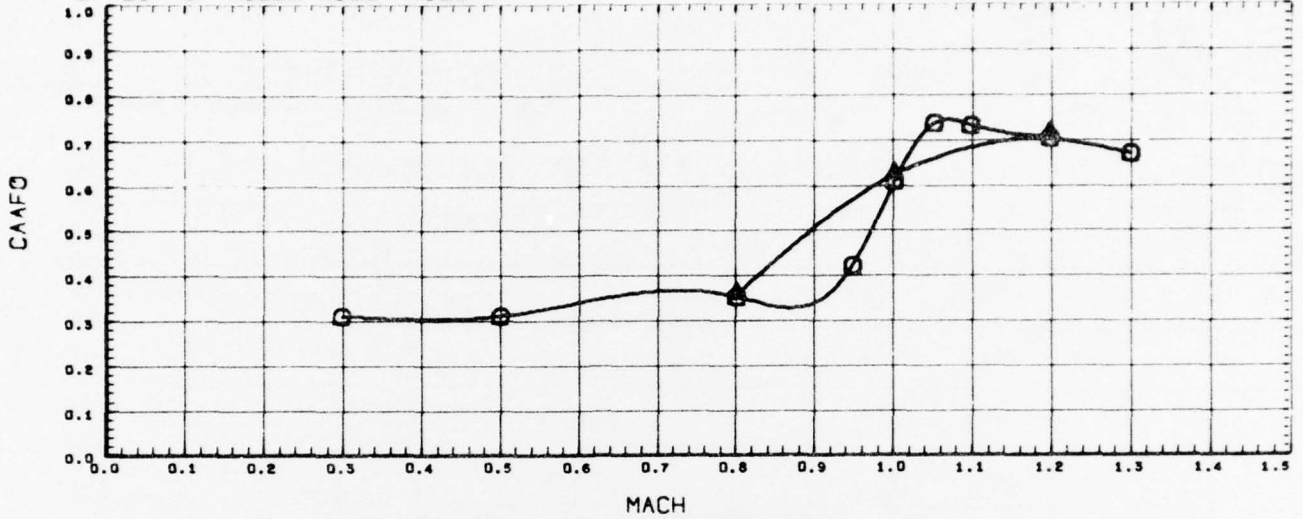

DATA SET SYMBOL	CONFIGURATION DESCRIPTION	PHI	M-LGTH	LS-LGH	REFERENCE INFORMATION
(BTARD2)	AEDC TEST PWT-4T201 CONE-CYL. W/RING TAIL, N1R2	0.000	1.500	3.250	SREF 7.0686 SQ. IN.
(BTARD5)	AEDC TEST PWT-4T201 CONE-CYL. W/RING TAIL, N1R2	180.000	1.500	3.250	LREF 3.0000 INCHES
					BREF 3.0000 INCHES
					YNRP 0.0000 INCHES
					YNRP 0.0000 INCHES
					ZNRP 0.0000 INCHES
					SCALE 0.0000 NONE

EFFECT OF MODEL ROLL ANGLE

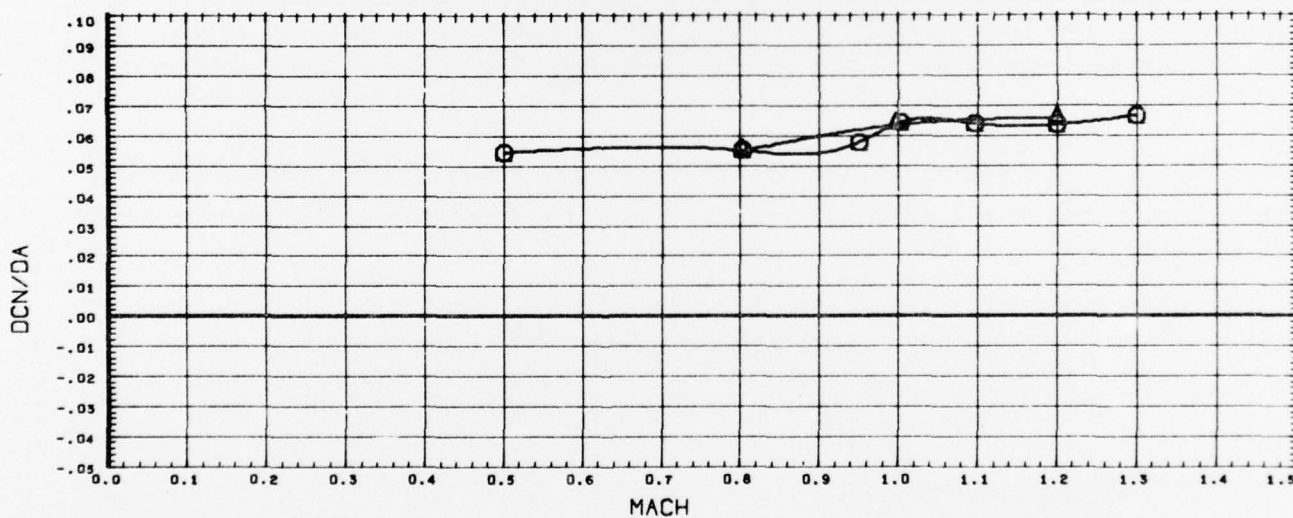
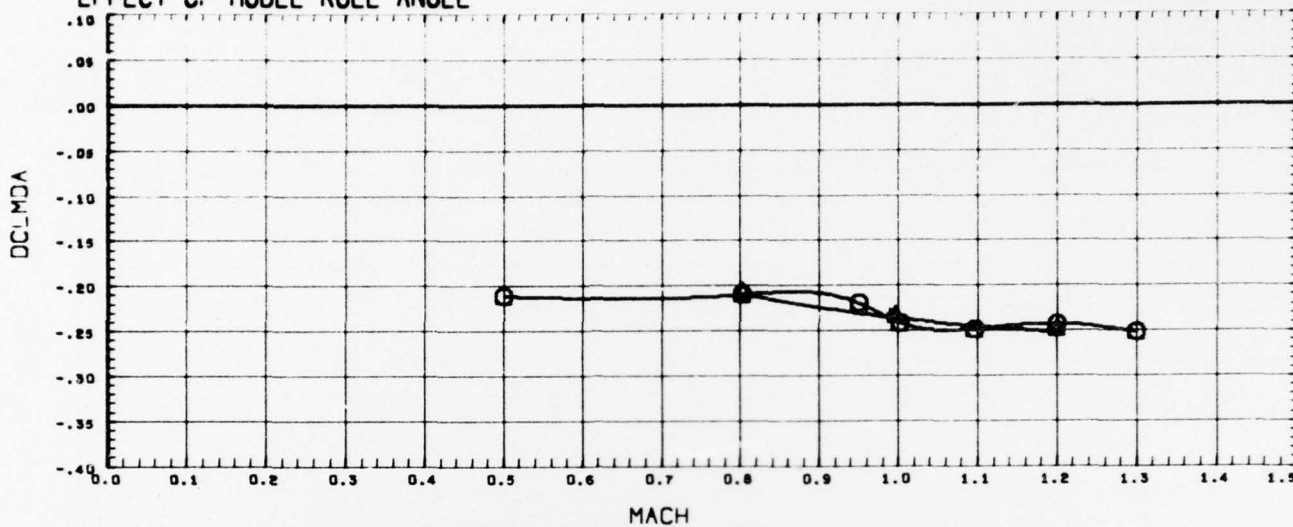

DATA SET SYMBOL	CONFIGURATION DESCRIPTION	PHI	M-LGTH	LS-LGH	REFERENCE INFORMATION
(RTAR18) \square	AEDC TEST PWT-4T201 CONE-CYL. W/RING TAIL,N1R2C2	0.000	1.500	3.250	SREF 7.0686 SQ. IN.
(RTAR19) \triangle	AEDC TEST PWT-4T201 CONE-CYL. W/RING TAIL,N1R2C2	45.000	1.500	3.250	LREF 3.0000 INCHES
					BREF 3.0000 INCHES
					XMRP 0.0000 INCHES
					YMRP 0.0000 INCHES
					ZMRP 0.0000 INCHES
					SCALE 0.0000 NONE

EFFECT OF MODEL ROLL ANGLE

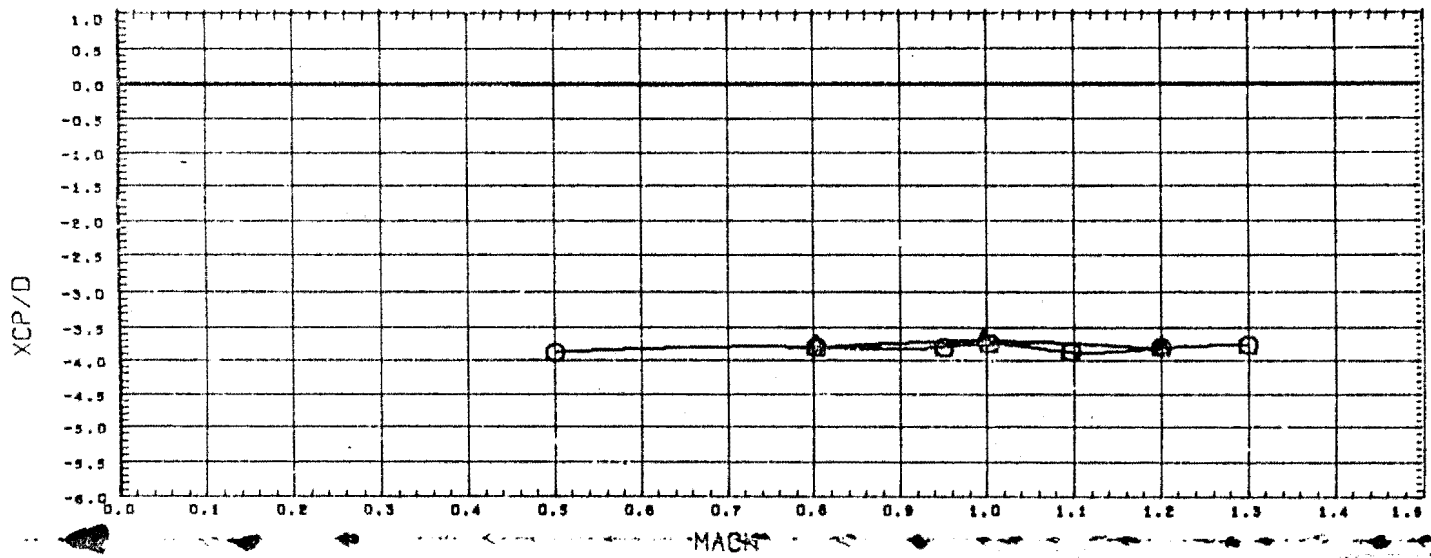
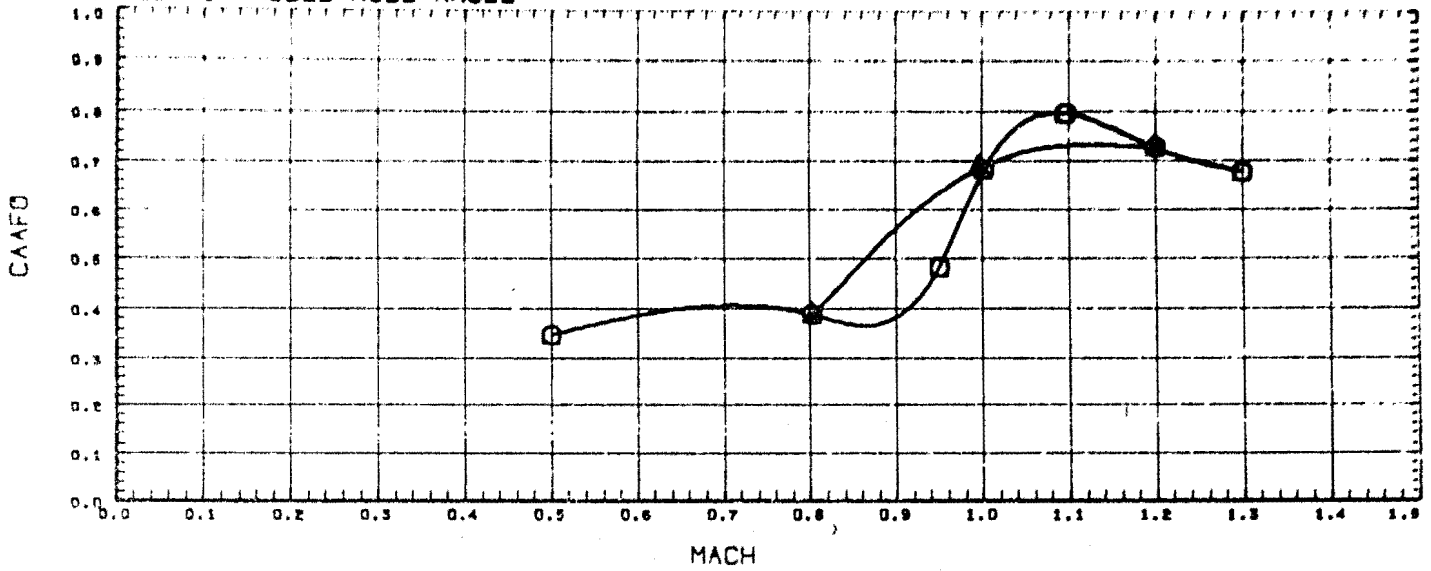

DATA SET SYMBOL	CONFIGURATION DESCRIPTION	PHI	M-LGTH	LS-LGH	REFERENCE INFORMATION
(BTAR18)	AEDC TEST PWT-4T201 CONE-CYL. W/RING TAIL,N1R2C2	0.000	1.500	3.250	SREF 7.0686 INCHES
(BTAR19)	AEDC TEST PWT-4T201 CONE-CYL. W/RING TAIL,N1R2C2	45.000	1.500	3.250	LREF 3.0000 INCHES
					BREF 3.0000 INCHES
					YMRP 0.0000 INCHES
					YMRP 0.0000 INCHES
					ZMRP 0.0000 INCHES
					SCALE 0.0000 NONE

EFFECT OF MODEL ROLL ANGLE

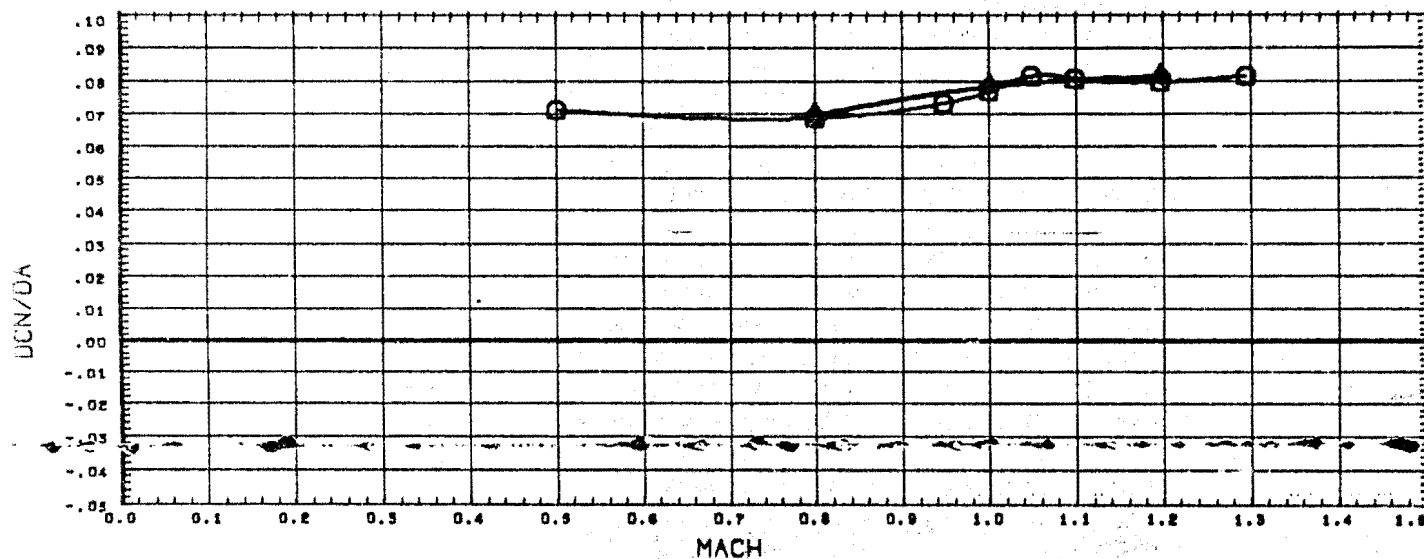
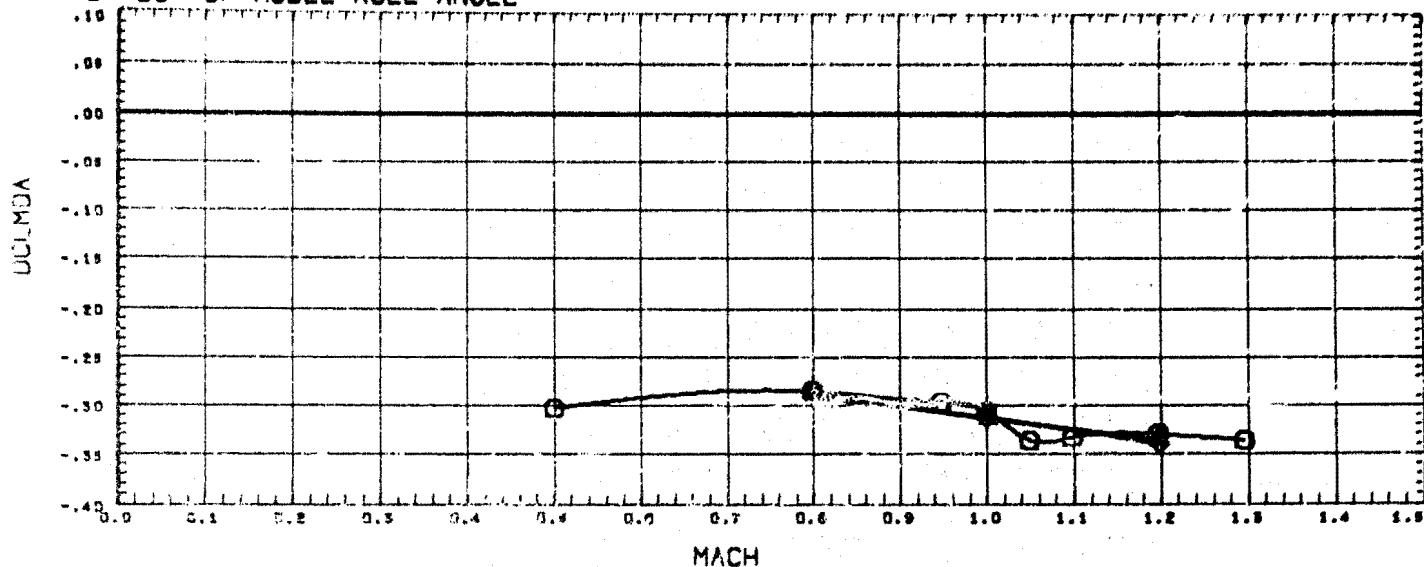

DATA SET SYMBOL	CONFIGURATION DESCRIPTION	PHI	M-LGN	LS-LGN	REFERENCE INFORMATION
(RTAR25)	AEDC TEST PWT-4T201 CONE-CYL. W/RING TAIL,N1R2C5	0.000	1.500	3.250	SREF 7.0686 50. IN.
(RTAR26)	AEDC TEST PWT-4T201 CONE-CYL. W/RING TAIL,N1R2C5	22.500	1.500	3.250	LREF 3.0000 INCHES
(RTAR27)	AEDC TEST PWT-4T201 CONE-CYL. W/RING TAIL,N1R2C5	45.000	1.500	3.250	BREF 3.0000 INCHES
					XMRP 0.0000 INCHES
					YMRP 0.0000 INCHES
					ZMRP 0.0000 INCHES
					SCALE 0.0000 NONE

EFFECT OF MODEL ROLL ANGLE

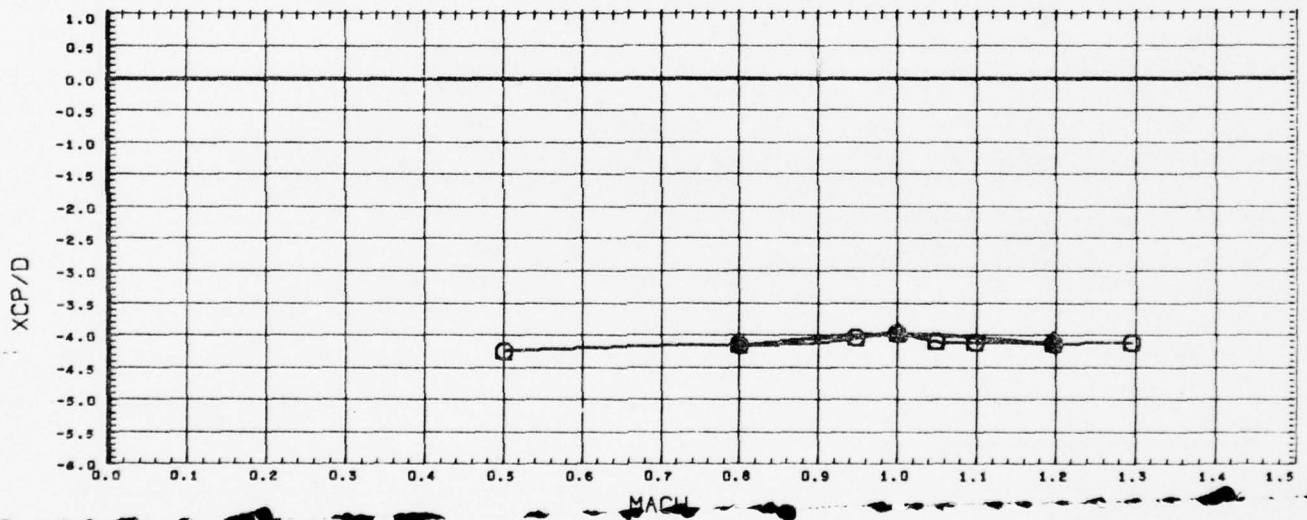
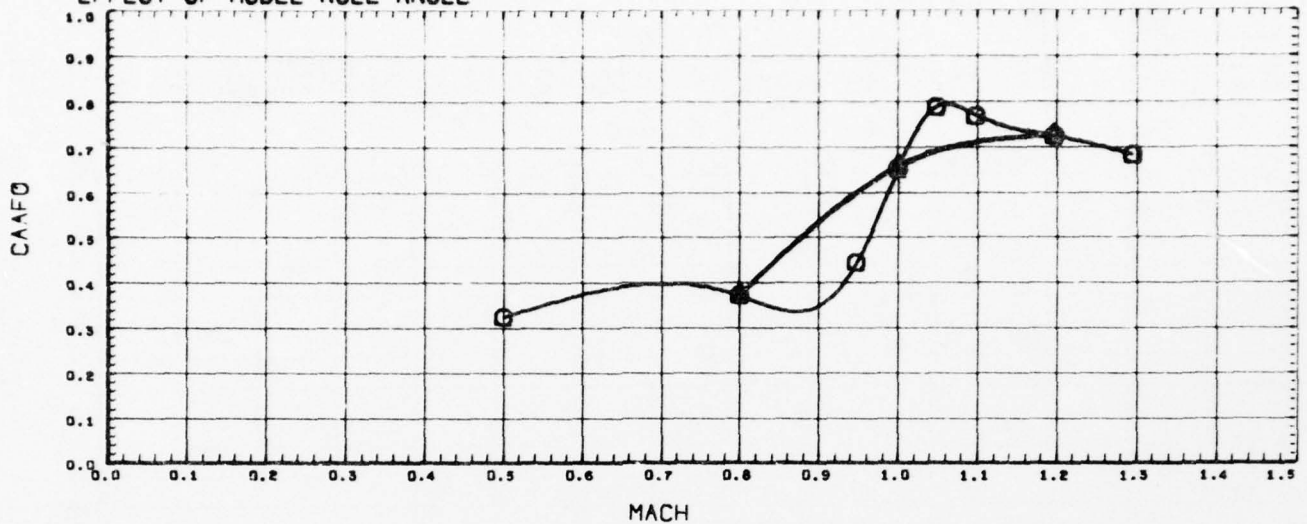

DATA SET SYMBOL	CONFIGURATION DESCRIPTION	PHI	M-LGTH	LS-LGH	REFERENCE INFORMATION
(BTAR25)	⊙ AEDC TEST PWT-4T201 CONE-CYL. W/RING TAIL,N1R2C5	0.000	1.500	3.250	SREF 7.0666 SQ. IN.
(BTAR26)	△ AEDC TEST PWT-4T201 CONE-CYL. W/RING TAIL,N1R2C5	22.500	1.500	3.250	LREF 3.0000 INCHES
(BTAR27)	◇ AEDC TEST PWT-4T201 CONE-CYL. W/RING TAIL,N1R2C5	45.000	1.500	3.250	BREF 3.0000 INCHES
					XMRP 0.0000 INCHES
					YMRP 0.0000 INCHES
					ZMRP 0.0000 INCHES
					SCALE 0.0000 NONE