

AD-A039 710

DAVID W TAYLOR NAVAL SHIP RESEARCH AND DEVELOPMENT CE--ETC F/G 13/10
INVESTIGATION OF THE EFFECTIVENESS OF AN ANTIPTCHING FIN AND F--ETC(U)
APR 77 H D JONES, D M GERZINA

UNCLASSIFIED

SPD-762-01

NL

1 of 1
ADA039 710



END
DATE
FILMED
6-77

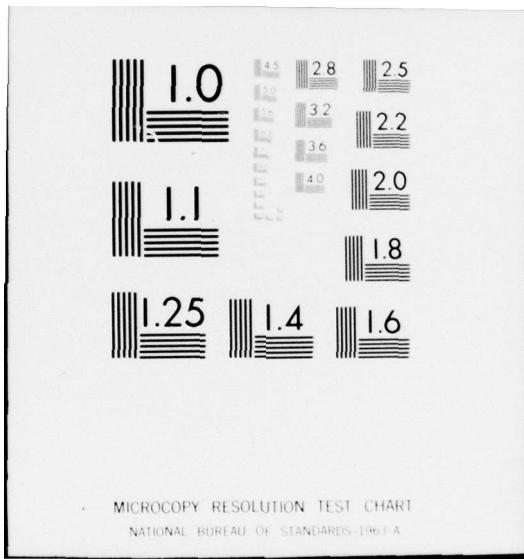

MICROCOPY RESOLUTION TEST CHART
NATIONAL BUREAU OF STANDARDS-1963-A

AD A 039710

SPD-762-01

INVESTIGATION OF THE EFFECTIVENESS OF AN ANTIPTCHING FIN AND FIN STRUT COMBINATION ON THE MARINER

12
B S

DAVID W. TAYLOR NAVAL SHIP RESEARCH AND DEVELOPMENT CENTER



Bethesda, Md. 20084

INVESTIGATION OF THE EFFECTIVENESS OF AN ANTIPTCHING FIN AND FIN STRUT COMBINATION ON THE MARINER

by
Harry D. Jones
and
David M. Gerzina

DDC
RECEIVED
MAY 23 1977
A

APPROVED FOR PUBLIC RELEASE: DISTRIBUTION UNLIMITED

AD NO. _____
DDC FILE COPY

SHIP PERFORMANCE DEPARTMENT

April 1977

SPD-762-01

MAJOR DTNSRDC ORGANIZATIONAL COMPONENTS

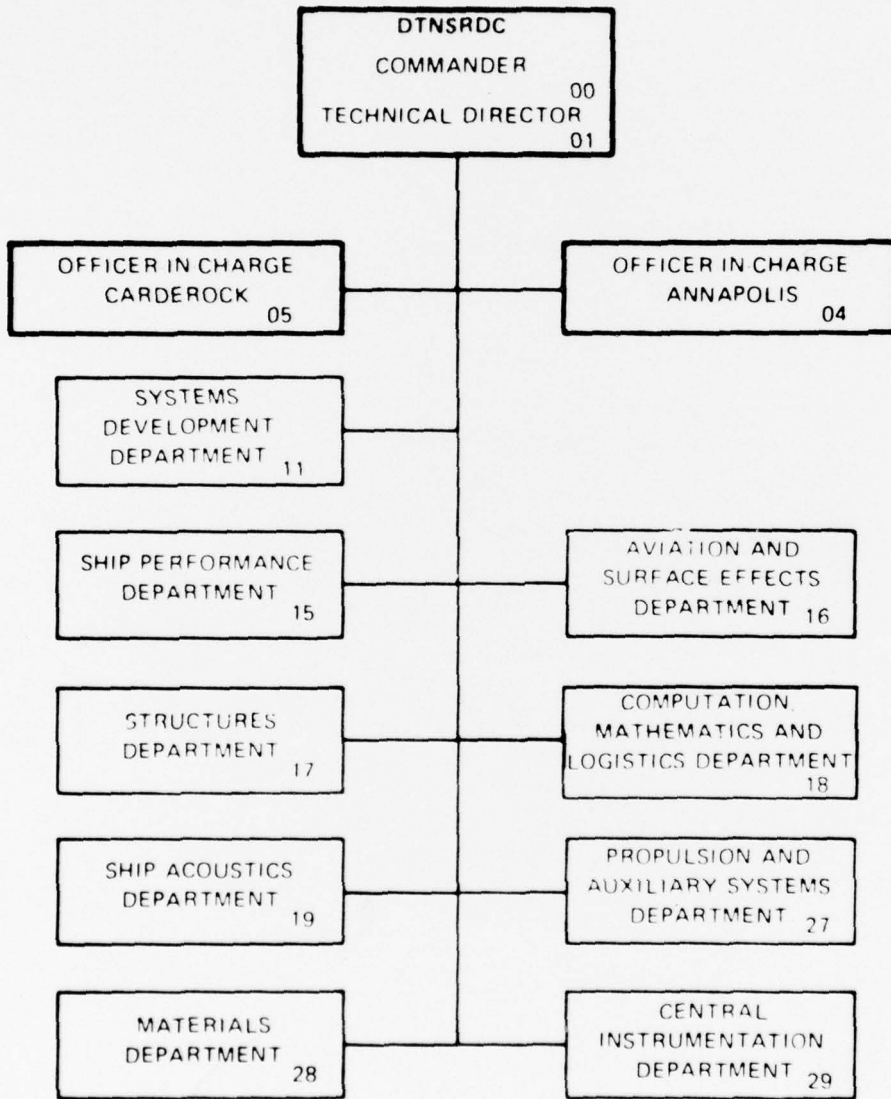

SEARCHED INDEXED
SERIALIZED FILED
APR 1964
DTNSRDC

A

UNCLASSIFIED

SECURITY CLASSIFICATION OF THIS PAGE (When Data Entered)

14) REPORT DOCUMENTATION PAGE		READ INSTRUCTIONS BEFORE COMPLETING FORM
1. REPORT NUMBER DTNSRDC SPD-762-01	2. GOVT ACCESSION NO.	3. RECIPIENT'S CATALOG NUMBER
6) 4. TITLE (and Subtitle) INVESTIGATION OF THE EFFECTIVENESS OF AN ANTI-PITCHING FIN AND FIN STRUT COMBINATION ON THE MARINER		5. TYPE OF REPORT & PERIOD COVERED
		6. PERFORMING ORG. REPORT NUMBER
10) 7. AUTHOR(s) Harry D. Jones and David M. Gerzina		8. CONTRACT OR GRANT NUMBER(s)
9. PERFORMING ORGANIZATION NAME AND ADDRESS David W. Taylor Naval Ship R&D Center Ship Performance Department Bethesda, Maryland 20084		10. PROGRAM ELEMENT, PROJECT, TASK AREA & WORK UNIT NUMBERS Project Order Nos. N6519776 P060234 & WR66398, Work Unit Nos. 1-1568-859 & 1-1504-100
11. CONTROLLING OFFICE NAME AND ADDRESS Naval Ship Engineering Center Washington, D.C. 20362		12. REPORT DATE 11) April 1977
14. MONITORING AGENCY NAME & ADDRESS (if different from Controlling Office) 12) 22p.		13. NUMBER OF PAGES 21
		15. SECURITY CLASS. (of this report) Unclassified
		15a. DECLASSIFICATION DOWNGRADING SCHEDULE
16. DISTRIBUTION STATEMENT (of this Report) APPROVED FOR PUBLIC RELEASE: DISTRIBUTION UNLIMITED		
17. DISTRIBUTION STATEMENT (of the abstract entered in Block 20, if different from Report)		
18. SUPPLEMENTARY NOTES		
19. KEY WORDS (Continue on reverse side if necessary and identify by block number) Antipitch fin, Experimental, Analytical, Strut, Seaworthiness		
20. ABSTRACT (Continue on reverse side if necessary and identify by block number) The presence of an antipitching fin attached at the hull baseline is known to cause severe hull vibrations. Two conditions thought to contribute to this problem are the collapse of the deformed wave surface profile above the fin and by fin re-entry after a bow fin emergence. An experimental investigation was conducted to determine the effect of increased strut length in reducing these conditions on a MARINER model equipped with an antipitching bow fin. Analytical predictions were also made to determine the effectiveness of a bow fin in		

DD FORM 1473 1 JAN 73

EDITION OF 1 NOV 65 IS OBSOLETE
S/N 0102-LF-014-6601

UNCLASSIFIED

SECURITY CLASSIFICATION OF THIS PAGE (When Data Entered)

389.694

13

UNCLASSIFIED

SECURITY CLASSIFICATION OF THIS PAGE (When Data Entered)

reducing the pitching motion of the MARINER hull in a seaway. The antipitching fin used in the MARINER experimental investigation was a flat plate with a geometric aspect ratio equal to that of the flat plate fin used in earlier work by Ochi. The effect of foil shaped struts of different lengths, to increase the vertical separation between the fin and the keel of the model at the bow, was experimentally evaluated in regular waves. Visual observations (video coverage) of the experimental investigation indicated: (1) the reduction in size and number of wave surface profile deformations for some of the wave conditions investigated, and (2) the obvious reduction of fin emergences, with increasing strut length. The reduction in the pitching motion resulting from the addition of the bow fin to the MARINER hull, as is indicated by the analytical investigation, is not considered significant as the motion is not excessive without the antipitching fin.

TABLE OF CONTENTS

	Page
ABSTRACT	1
ADMINISTRATIVE INFORMATION	1
INTRODUCTION	2
SHIP AND MODEL PARTICULARS	3
EXPERIMENTAL PROCEDURE	4
ANALYTICAL PROCEDURE	5
RESULTS AND DISCUSSION	5
CONCLUDING REMARKS	7

LIST OF TABLES

Table 1 - MARINER Ship and Model Particulars	8
Table 2 - MARINER Antipitching Fin Particulars	8
Table 3 - MARINER Antipitching Fin Pressure Gauge Data as Recorded for a Wavelength to Ship Length Ratio of 1.0	9
Table 4 - MARINER Antipitching Fin Pressure Gauge Data as Recorded for a Wavelength to Ship Length Ratio of 1.25	10

LIST OF FIGURES

Figure 1 - Pressure Gauge Location for Mariner Model Antipitching Fin Investigation	11
Figure 2 - Nondimensional Transfer Functions of Pitch versus Ship Speed as Measured for Mariner Model with and without Antipitching Fin and Strut for a Wavelength to Ship Length Ratio of 1.0	12
Figure 3 - Nondimensional Transfer Functions for Pitch, Heave and Acceleration (Absolute Motion) at Station 0.76 for Ship Speeds of 12.5 and 20 Knots	13

	Page
Figure 4 - Pitch, Heave, and Acceleration at Station 0.76 Single Amplitude Values versus Wave Height for a Ship Speed of 12.5 Knots	14
Figure 5 - Pitch, Heave, and Acceleration at Station 0.76 Single Amplitude Values versus Wave Height for a Ship Speed of 20.0 Knots	15
Figure 6 - Wave Profiles Above Antipitching Fin for a Ship Speed of 12.5 Knots	16
Figure 7 - Comparison of Analytical Predictions of the Pitch Motion of the Mariner with and without a Bow Fin	17

ABSTRACT

The presence of an antipitching fin attached at the hull baseline is known to cause severe hull vibrations. Two conditions thought to contribute to this problem are the collapse of the deformed wave surface profile above the fin and by fin re-entry after a bow fin emergence. An experimental investigation was conducted to determine the effect of increased strut length in reducing these conditions on a MARINER model equipped with an antipitching bow fin. Analytical predictions were also made to determine the effectiveness of a bow fin in reducing the pitching motion of the MARINER hull in a seaway. The antipitching fin used in the MARINER experimental investigation was a flat plate with a geometric aspect ratio equal to that of the flat plate fin used in earlier work by Ochi. The effect of foil shaped struts of different lengths, to increase the vertical separation between the fin and the keel of the model at the bow, was experimentally evaluated in regular waves. Visual observations (video coverage) of the experimental investigation indicated: (1) the reduction in size and number of wave surface profile deformations for some of the wave conditions investigated, and (2) the obvious reduction of fin emergences, with increasing strut length. The reduction in the pitching motion resulting from the addition of the bow fin to the MARINER hull, as is indicated by the analytical investigation, is not considered significant as the motion is not excessive without the antipitching fin.

ADMINISTRATIVE INFORMATION

This work was funded by the Naval Ship Engineering Center (NAVSEC) Project Order Numbers N6519776 P060234 dated 30 June 1976 for the experimental work and N6519776 WR66398 dated 24 September 1976 for the analytical study and was identified as Work Unit Number 1-1568-859. The analytical investigation was also partially supported under the Conventional Ship Seakeeping Research and Development Program, identified as Work Unit Number 1-1504-100.

INTRODUCTION

As part of a program to evaluate the effectiveness of increased strut length in reducing antipitching fin-induced hull vibrations, an experimental investigation was conducted using an existing MARINER model. To determine the effectiveness of a bow fin in reducing the pitching motion, an analytical investigation was made for the MARINER hull form in various long-crested irregular head waves with and without the fin for comparison.

The experimental investigation was conducted in the Maneuvering and Sea-keeping Facility at the David W. Taylor Naval Ship R&D Center (DTNSRDC) with an existing 21.84-ft (6.66 m) MARINER model equipped with an antipitching fin at the bow. Previous investigations indicated a decrease in pitching motion with the presence of an antipitching fin; however, a severe problem of fin-induced hull vibration was also experienced.¹ The two principal causes of the hull vibration are thought to be an impact force applied to the fin upon re-entering the water after fin emergence, and second, the collapse of the deformed wave surface profile on the top surface of the fin and on the side of the ship's hull. This experimental investigation was to determine the effectiveness of reducing fin impacts by adding a strut between the ship's keel and the fin thus lowering the fin in the water.

The experiments were conducted at two forward speeds in head regular waves at three primary wavelengths and four wave steepnesses. Regular waves with wavelength to ship length ratios of approximately 0.75, 1.0, and 1.25 with wave steepnesses of about 1/50 to 1/24 were investigated. Four configurations of the MARINER model with antipitching fin were considered: no strut (fin only); 8-ft strut (2.44 m); 12-ft strut (3.66 m); and 16-ft strut (4.88 m). In addition to the model motions, pressures on the hull, strut and fin were measured and visual records of the model's bow section were made on video tape.

¹Ochi, Kazuo M., "Hydroelastic Study of a Ship Equipped with an Antipitching Fin," David Taylor Model Basin Report 1455 (Oct 1962).

The analytical investigation was done using an existing computer program^{2,3} designed to predict the motions of a ship in waves. This program also allows for the incorporation of a bow fin in making these predictions. This investigation was carried out in head seas only at ship speeds of 12.5 and 20.0 knots in seaways having significant wave heights of 3.5, 5.5, and 7.5 metres. For each seaway a range of modal periods of from 8 to 20 seconds was investigated using the Bretschneider representation of the seaways.

SHIP AND MODEL PARTICULARS

The MARINER is 528 feet (160.9 m) between perpendiculars. The wooden model used for the antipitching fin investigation was built to a scale ratio of 24.175 and designated Model Number 4414. Table 1 presents the principal characteristics of the ship and model. The 21.84-ft (6.66 m) model was ballasted to a scaled equivalent displacement of 21,093 long tons (21,440 tonnes) at an even keel draft of 29.75 feet (9.07 m). Since investigations were limited to head seas, the principal dynamic characteristic of the model was the longitudinal radius of gyration (gyradius) which was obtained by the Bifilar pendulum method and set equal to 24 percent of the length between perpendiculars. As indicated in Table 2, a wooden rectangular shaped fin (flat plate) was fixed to the bow of the model with the midchord located 3.8 percent of the length between perpendiculars aft of the forward perpendicular (Station 0.76). The fin was attached directly to the model's keel or spaced at full-scale equivalent increments of 4 feet (1.22 m) below the keel by a NACA 0020 foil shaped strut with a chord length equal to the chord of the fin.

²McCreight, K.K. and C.M. Lee, "Manual for Monohull or Twinhull Ship Motion Prediction Computer Program," DTNSRDC Report SPD-686-02 (1976).

³Lee, C.M., "Theoretical Prediction of Motion of Small-Waterplane-Area, Twin Hull (SWATH) Ships in Waves," DTNSRDC Report 76-0046 (Dec 1976).

EXPERIMENTAL PROCEDURE

The MARINER model antipitch fin experiments were conducted in head regular waves at two Froude scaled speeds equivalent to 12.5 and 20.0 knots. The regular waves were limited to wavelength to ship length ratios of 0.75, 1.00, and 1.25 at four wave steepnesses ranging from about 1/50 to 1/24. The wave conditions investigated were considered severe and representative of extreme conditions.

The model was equipped as a free-running, self-propelled model, instrumented to measure pitch, heave, roll, surge, sway, yaw, absolute motion at Station 0.76 and eight pressures on the model's hull, strut and fin. Results are presented for the measurements of pitch, heave, absolute motion at Station 0.76, and four of the pressure gauges. The reduction in the number of pressure gauges presented is the result of transducer failure early in the experimental program. The locations of the four pressure gauges are shown in Figure 1 and are described as follows: pressure gauge A was located on the upper surface of the fin 75 percent of one-half the span to starboard of the centerline (16.2 ft (4.94 m) to starboard); pressure gauge B was located on the port surface of the strut 6.85 ft (2.09 m) above the top surface of the fin and was not installed for the no strut configuration; pressure gauge C was located on the starboard surface of the strut 6.85 ft (2.09 m) above the top surface of the fin and for the no strut configuration was positioned 6.85 ft (2.09 m) above the keel on the starboard surface of the hull; pressure gauge D was located on the port side of the hull 6.85 ft (2.09 m) above the keel. All the pressure gauges were longitudinally located at Station 0.76, a distance of one-half of the chord length aft of the leading edge of the fin.

The motion data, along with some of the pressures, were recorded on magnetic tape and visually displayed on strip charts. In addition, the motion data signals were input to an Interdata computer on the carriage from which all regular wave results were obtained. During the model experiments, video coverage of the fin location was made in an effort to observe the wave surface profile deformation as the strut length was increased.

ANALYTICAL PROCEDURE

The analytical investigation was carried out, using the same MARINER hull form as in the experiments, with an existing computer program^{2,3} which predicts the motions of a ship in waves. The analytical predictions were made for the MARINER with and without the antipitch bow fin. Ship speeds of 12.5 and 20.0 knots were investigated analytically in long-crested head waves represented by Bretschneider theoretical seaways having significant wave heights of 3.5, 5.5, and 7.5 metres. In each case a range of modal periods of the wave spectra of from 8 to 20 seconds was investigated.

The computer program utilized incorporates a linear strip theory to predict the hydrodynamic coefficients of a predominately nonviscous nature, i.e., added mass and wavemaking damping. The effects of fixed stabilizing fins are included in the linear response region of a ship in waves. This program predicts the motion responses of a ship in regular long-crested waves based on the linear strip theory as indicated. These motions are then input to a computer program which utilizes the principles of linear superposition along with the Bretschneider theoretical formulation of seaway spectra to predict the root mean square motions of the ship.

RESULTS AND DISCUSSION

Previous experimental investigations have been carried out for the MARINER with an antipitching fin attached at the baseline. Results of θ_{chi} ¹ are shown in Figure 2. Seen here are the experimental results obtained in reducing pitching motion on a MARINER model with a rectangular antipitching fin (flat plate) as recorded by θ_{chi} in regular waves with a wavelength to ship length ratio of 1.0 and a wave steepness of 1/20. Results of the present experiments under similar wave conditions (wave steepness of 1/24) at two speeds are also indicated. These results were obtained with an equivalent size and shape fin and various strut lengths. As seen, agreement is quite good indicating that the lowering of the fin on a strut has negligible effects on the ship's pitching motion. Presented in Figure 3 are the nondimensional transfer functions for pitch, heave, and acceleration (absolute motion) at Station 0.76

for ship speeds of 12.5 and 20.0 knots. Results are given for each of the model configurations investigated for wave steepnesses ranging from 1/50 to 1/24 at wavelengths to ship length ratios of 0.75, 1.00, and 1.25. As indicated in Figure 2 and in Figure 3, variations in length of strut had negligible effect on the measured ship motions. Figure 4 presents the MARINER model pitch, heave, and acceleration single amplitude values at Station 0.76 as a function of wave height for a ship speed of 12.5 knots. For each configuration, responses are indicated as being quite linear with wave height at a wavelength to ship length ratio of 1.0 with some nonlinearity occurring at the longer wavelength. Figure 5 presents similar results for a ship speed of 20 knots.

Pressure gauge data for wavelength to ship length ratios of 1.0 and 1.25 are presented in Tables 3 and 4, respectively. As seen, the maximum and average pressure recorded, number of impacts, number of events and rate of impacts are presented for each of the four pressure gauge locations. The number of impacts and number of events differ in that an event is considered any large pressure disturbance seen by the pressure gauge even though an impact did not occur, and in all instances the number of events is greater than or equal to the number of impacts. The pressure gauge results are valid only to indicate trends and are not intended to be used as statistical predictions due to the short duration of run time and limited number of wave encounters. The trends shown by the pressure gauge data indicate an improvement in the rate of impacts with the presence of the foil shape strut. No conclusive results were obtained indicating which strut length was best; however, in all but a few instances the rate of impacts decreased for the long strut lengths. The magnitude of the pressures recorded appeared to be unaffected by the strut, and the maximum and average values tabulated show no trend to decrease with increasing strut length.

Presented in Figure 6 are sketches of the deformed wave surface profile above the fin for each of the strut configurations investigated. The wave surface profiles were observed from video tape coverage of the bow of the model. The sketches shown are representative of experiments conducted at a wavelength-to-ship length ratio of 1.0 and a wave steepness of 1/30 at a speed of 12.5 knots. As illustrated, the degree of deformation is greatly

reduced as the strut length is increased. Observations of wave deformation under more severe wave conditions, e.g., wavelength to ship length ratio of 1.0 and wave steepness of $1/24$ indicated larger and more pronounced effects for all strut lengths considered. This deformation is probably due to flow disturbance as the fin nears the water surface.

The results of the analytical investigation are presented in Figure 7. Given here is a comparison of the root mean square single amplitude pitch for the MARINER with and without the bow fin. The comparison is shown for ship speeds of 12.5 and 20.0 knots in seaways of 3.5, 5.5, and 7.5 metres significant height for a range of modal periods from 8 to 20 seconds. It may be seen in this figure that the addition of the bow fin results in a modest reduction in the pitch motion of up to approximately 30 percent; however, the motion is mild initially.

CONCLUDING REMARKS

Since there is no possibility of performing the experiment correctly scaled for the occurrence of cavitation and ventilation, a flat plate was used to represent the fin. Essentially, fin/strut cavitation and cavitation induced ventilation will occur at much smaller ship speeds and fin submergence depths than indicated by this type of model experiment. Also, the benefits of fin submergence for reducing cavitation are underestimated by the model experiment.

The surface wave deformation, shown in Figure 6, is considered to be pertinent to full-scale, in the absence of cavitation-induced ventilation, and indicates one effect of shallow submergence.

The reduction of pitching motion indicated by Figures 2 and 7 is not considered to be significant as pitching is not excessive for the MARINER without the bow fin.

TABLE 1 - MARINER SHIP AND MODEL PARTICULARS

Scale Ratio = 24.175

	Ship	Model
Length Between Perpendiculars, feet (metre)	528 (160.9)	21.84 (6.66)
Beam, feet (metre)	76 (23.16)	3.14 (.957)
Draft, feet (metre)	29.75 (9.07)	1.23 (.375)
Displacement, long tons (tonnes)	21,093 _{SW} (21,440)	1.455 _{FW} (1.479)
Longitudinal Gyradius, percent length between perpendiculars	.24	.24

TABLE 2 - MARINER ANTIPITCHING FIN PARTICULARS

Scale Ratio = 24.175

	Ship	Model
Location, percent of length between perpendiculars aft of forward perpendicular	3.8	3.8
Span, feet (metre)	43.2 (13.17)	1.787 (.545)
Chord, feet (metre)	20.0 (6.10)	.828 (.252)
Aspect Ratio	2.16	2.16
Thickness, feet (metre)	1.51 (.460)	.063 (.019)

TABLE 3 - MARINER ANTI-PITCHING FIN PRESSURE GAUGE DATA AS RECORDED
FOR A WAVELENGTH TO SHIP LENGTH RATIO OF 1.0

Experimental Configuration	Run Time min	Pressure Gage "A" Located on Top of Fin				Pressure Gage "B" Located on Port Side of Strut 6.85 ft (2.09 m) Above Fin*				Pressure Gage "C" Located on Stbd Side of Strut 6.85 ft (2.09 m) Above Fin*				Pressure Gage "D" Located on Port Side of Hull 6.85 ft (2.09 m) Above Keel			
		Max. psi (kPa)	Avg. psi (kPa)	No. of Imp. Event	Rate No./min	Max. psi (kPa)	Avg. psi (kPa)	No. of Imp. Event	Rate No./min	Max. psi (kPa)	Avg. psi (kPa)	No. of Imp. Event	Rate No./min	Max. psi (kPa)	Avg. psi (kPa)	No. of Imp. Event	Rate No./min
Wave Steepness = 1/50																	
No Strut	2.29	0 (0)	0 (0)	0 (0)	0 (0)	0 (0)	0 (0)	0 (0)	0 (0)	0 (0)	0 (0)	0 (0)	0 (0)	0 (0)	0 (0)	0 (0)	0 (0)
8' Strut (2.44 m)	2.65	0 (0)	0 (0)	0 (0)	0 (0)	0 (0)	0 (0)	0 (0)	0 (0)	15.6 (108)	15.6 (108)	1 (1)	.4	0 (0)	0 (0)	0 (0)	0 (0)
12' Strut (3.66 m)	2.42	0 (0)	0 (0)	0 (0)	0 (0)	5.0 (34)	5.0 (34)	1 (34)	.4	0 (0)	0 (0)	0 (0)	0 (0)	0 (0)	0 (0)	0 (0)	0 (0)
16' Strut (4.88 m)	2.90	0 (0)	0 (0)	0 (0)	0 (0)	6.2 (43)	6.2 (43)	1 (43)	.3	11.4 (79)	11.4 (79)	1 (79)	.3	0 (0)	0 (0)	0 (0)	0 (0)
Wave Steepness = 1/40																	
No Strut	2.29	5.0 (34)	5.0 (34)	1 (34)	.4	0 (0)	0 (0)	0 (0)	0 (0)	0 (0)	0 (0)	0 (0)	0 (0)	0 (0)	0 (0)	0 (0)	0 (0)
8' Strut (2.44 m)	2.65	0 (0)	0 (0)	0 (0)	0 (0)	0 (0)	0 (0)	4 (0)	0 (0)	0 (0)	0 (0)	0 (0)	0 (0)	0 (0)	0 (0)	0 (0)	0 (0)
12' Strut (3.66 m)	2.53	0 (0)	0 (0)	0 (0)	0 (0)	9.4 (65)	9.4 (65)	1 (65)	.4	0 (0)	0 (0)	0 (0)	0 (0)	0 (0)	0 (0)	0 (0)	0 (0)
16' Strut (4.88 m)	2.53	0 (0)	0 (0)	0 (0)	0 (0)	6.2 (43)	6.2 (43)	2 (43)	.8	0 (0)	0 (0)	0 (0)	0 (0)	0 (0)	0 (0)	0 (0)	0 (0)
Wave Steepness = 1/30																	
No Strut	4.71	0 (0)	0 (0)	0 (0)	0 (0)	0 (0)	0 (0)	15 (0)	0 (0)	7.4 (51)	5.2 (36)	7 (51)	1.5	17.6 (121)	9.2 (63)	5 (63)	1.1
8' Strut (2.44 m)	2.41	0 (0)	0 (0)	0 (0)	0 (0)	12.4 (86)	10.9 (75)	2 (75)	.8	7.4 (51)	7.4 (51)	1 (51)	.4	0 (0)	0 (0)	0 (0)	0 (0)
12' Strut (3.66 m)	2.30	0 (0)	0 (0)	0 (0)	0 (0)	12.4 (86)	6.9 (48)	3 (48)	1.3	9.4 (65)	9.4 (65)	1 (65)	.4	0 (0)	0 (0)	0 (0)	0 (0)
16' Strut (4.88 m)	5.08	0 (0)	0 (0)	0 (0)	0 (0)	9.4 (65)	8.2 (56)	3 (56)	.6	11.4 (79)	8.9 (62)	4 (62)	.8	0 (0)	0 (0)	0 (0)	0 (0)
Wave Steepness = 1/24																	
No Strut	1.58	21.3 (147)	14.4 (99)	3 (99)	1.9	11.2 (77)	8.2 (56)	5 (56)	1.1	18.9 (130)	12.6 (87)	5 (87)	3.2	13.9 (96)	11.9 (82)	3 (82)	1.9
8' Strut (2.44 m)	4.46	0 (0)	0 (0)	0 (0)	0 (0)	26.0 (180)	12.2 (84)	8 (84)	2.1	18.9 (130)	10.9 (75)	5 (75)	1.1	11.4 (79)	8.2 (56)	4 (56)	.9
12' Strut (3.66 m)	3.89	0 (0)	0 (0)	0 (0)	0 (0)	9.4 (65)	6.0 (41)	3 (41)	.6	25.3 (174)	13.9 (96)	4 (96)	1.0	11.4 (79)	11.4 (79)	1 (79)	.3
16' Strut (4.88 m)	5.06	0 (0)	0 (0)	0 (0)	0 (0)	0 (0)	0 (0)	4 (0)	0 (0)	0 (0)	0 (0)	0 (0)	0 (0)	9.4 (65)	5.7 (39)	6 (39)	1.2

* For the No Strut configuration experiments, P.G. "B" was not installed and P.G. "C" was located on the stbd side of the hull opposite P.G. "D".

TABLE 4 - MARINER ANTIPTITCHING FIN PRESSURE GAUGE DATA AS RECORDED FOR A WAVELENGTH TO SHIP LENGTH RATIO OF 1.25

Experimental Configuration	Run Time min	Pressure Gage "A" Located on Top of Fin				Pressure Gage "B" Located on Port Side of Strut 6.85 ft (2.09 m) Above Fin*				Pressure Gage "C" Located on Stbd Side of Strut 6.85 ft (2.09 m) Above Fin*				Pressure Gage "D" Located on Port Side of Hull 6.85 ft (2.09 m) Above Keel							
		Pressure Max. psi (kPa)	Avg. psi (kPa)	No. of Imp. Event	Rate of Imp. No./min	Pressure Max. psi (kPa)	Avg. psi (kPa)	No. of Imp. Event	Rate of Imp. No./min	Pressure Max. psi (kPa)	Avg. psi (kPa)	No. of Imp. Event	Rate of Imp. No./min	Pressure Max. psi (kPa)	Avg. psi (kPa)	No. of Imp. Event	Rate of Imp. No./min				
Wave Steepness = 1/50																					
No Strut	1.55	0 (0)	0 (0)	3	0	3.2 (22)	3.2 (22)	2	4	1	15.6 (108)	15.6 (108)	1	6	.6	15.6 (108)	10.4 (72)	5	7	3.2	
16' Strut (4.88 m)	2.08	0 (0)	0 (0)	0	0	0 (0)	0 (0)	0	0	0	0 (0)	0 (0)	0	3	0	0 (0)	0 (0)	0	0	0	
Wave Steepness = 1/40																					
No Strut	1.43	6.2 (43)	6.2 (43)	1	.7	0 (0)	0 (0)	0	3	0	0 (0)	6.2 (43)	6.2 (43)	1	.5	0 (0)	17.6 (121)	13.6 (94)	4	7	2.8
8' Strut (2.44 m)	2.20	0 (0)	0 (0)	0	0	0 (0)	0 (0)	0	0	0	0 (0)	0 (0)	0 (0)	0	0	0 (0)	0 (0)	0	0	0	
Wave Steepness = 1/30																					
No Strut	1.56	0 (0)	0 (0)	0	4	0	0	0	0	0	32.7 (226)	14.4 (99)	5	12	3.2	28.3 (195)	10.9 (75)	5	10	3.2	
8' Strut (2.44 m)	1.95	5.0 (34)	5.0 (34)	1	.5	12.4 (86)	10.4 (72)	4	10	2.1	13.9 (96)	10.2 (70)	5	7	2.6	7.4 (51)	7.4 (51)	1	5	.5	
12' Strut (3.66 m)	1.79	0 (0)	0 (0)	0	3	0 (0)	0 (0)	0	7	0	0 (0)	0 (0)	0	5	0	5.0 (34)	5.0 (34)	1	2	.6	
16' Strut (4.88 m)	2.78	0 (0)	0 (0)	0	3	0 (0)	0 (0)	0	3	0	0 (0)	0 (0)	0	2	0	5.0 (34)	5.0 (34)	1	2	.4	
Wave Steepness = 1/24																					
8' Strut (2.44 m)	3.61	0 (0)	0 (0)	0	8	12.4 (86)	8.2 (56)	7	14	1.9	17.6 (121)	11.4 (79)	6	16	1.7	15.6 (108)	10.4 (72)	8	18	2.2	
12' Strut (3.66 m)	1.52	0 (0)	0 (0)	0	3	9.4 (65)	6.2 (43)	3	12	2.0	15.6 (108)	15.6 (108)	1	10	.7	7.4 (51)	7.4 (51)	5	8	3.3	
16' Strut (4.88 m)	1.67	0 (0)	0 (0)	0	6	26.0 (180)	18.1 (125)	3	11	1.8	20.1 (139)	13.6 (94)	4	12	2.4	9.4 (65)	6.9 (48)	4	10	2.4	

* For the No Strut configuration experiments, P.G. "B" was not installed and P.G. "C" was located on the stbd side of the hull opposite P.G. "D".

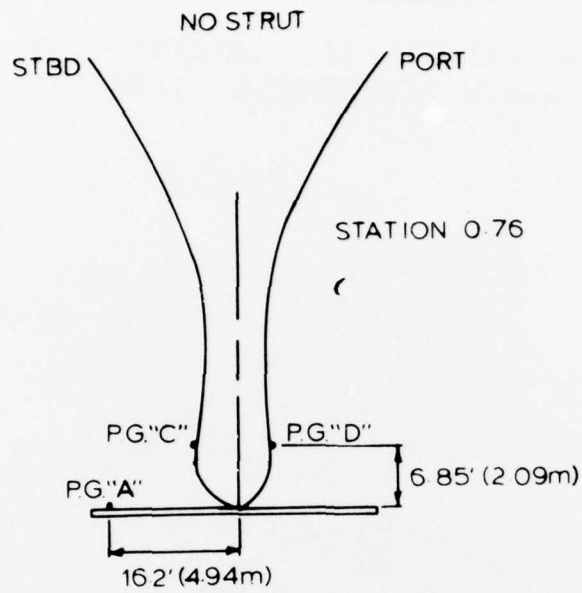

WITH 8'(2.44m), 12'(3.66m), 16'(4.88m) STRUT

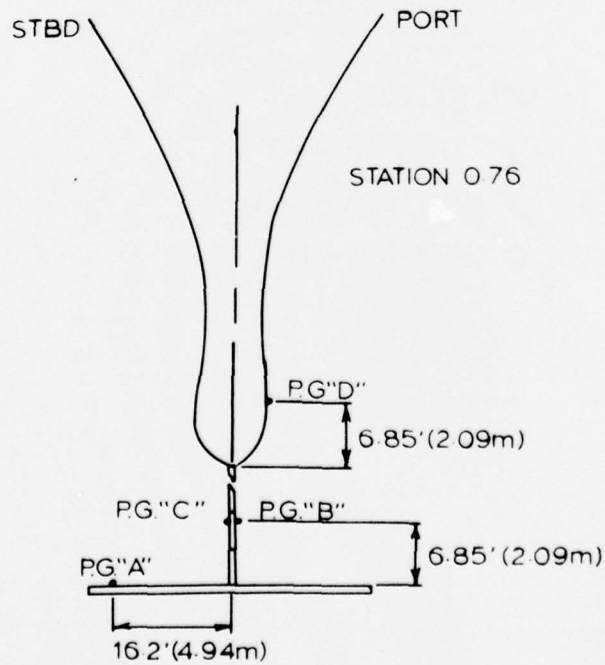

Figure 1 - Pressure Gauge Location for Mariner Model Antipitching Fin Investigation

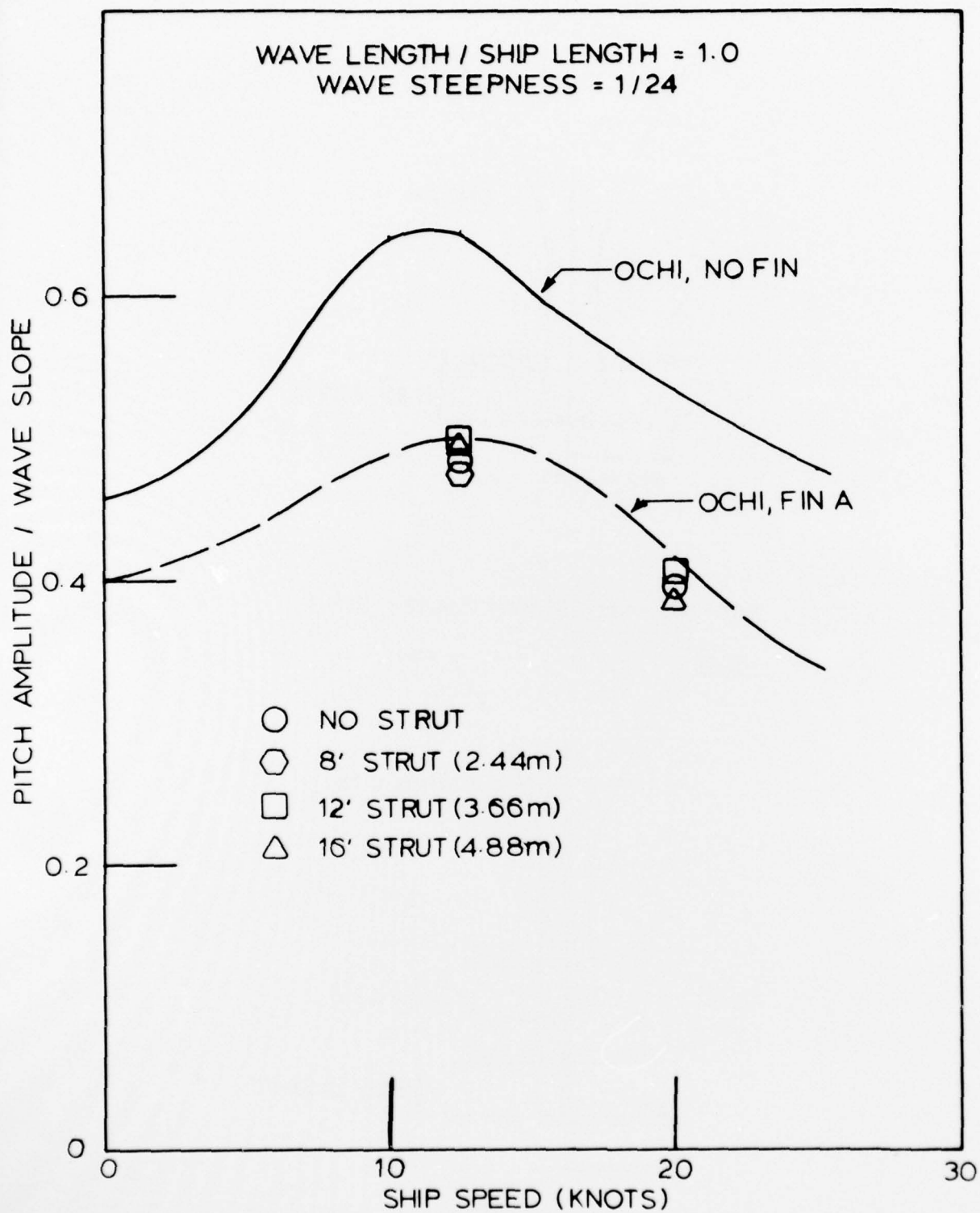

Figure 2 - Nondimensional Transfer Functions of Pitch versus Ship Speed as Measured for Mariner Model with and without Antipitching Fin and Strut for a Wavelength to Ship Length Ratio of 1.0

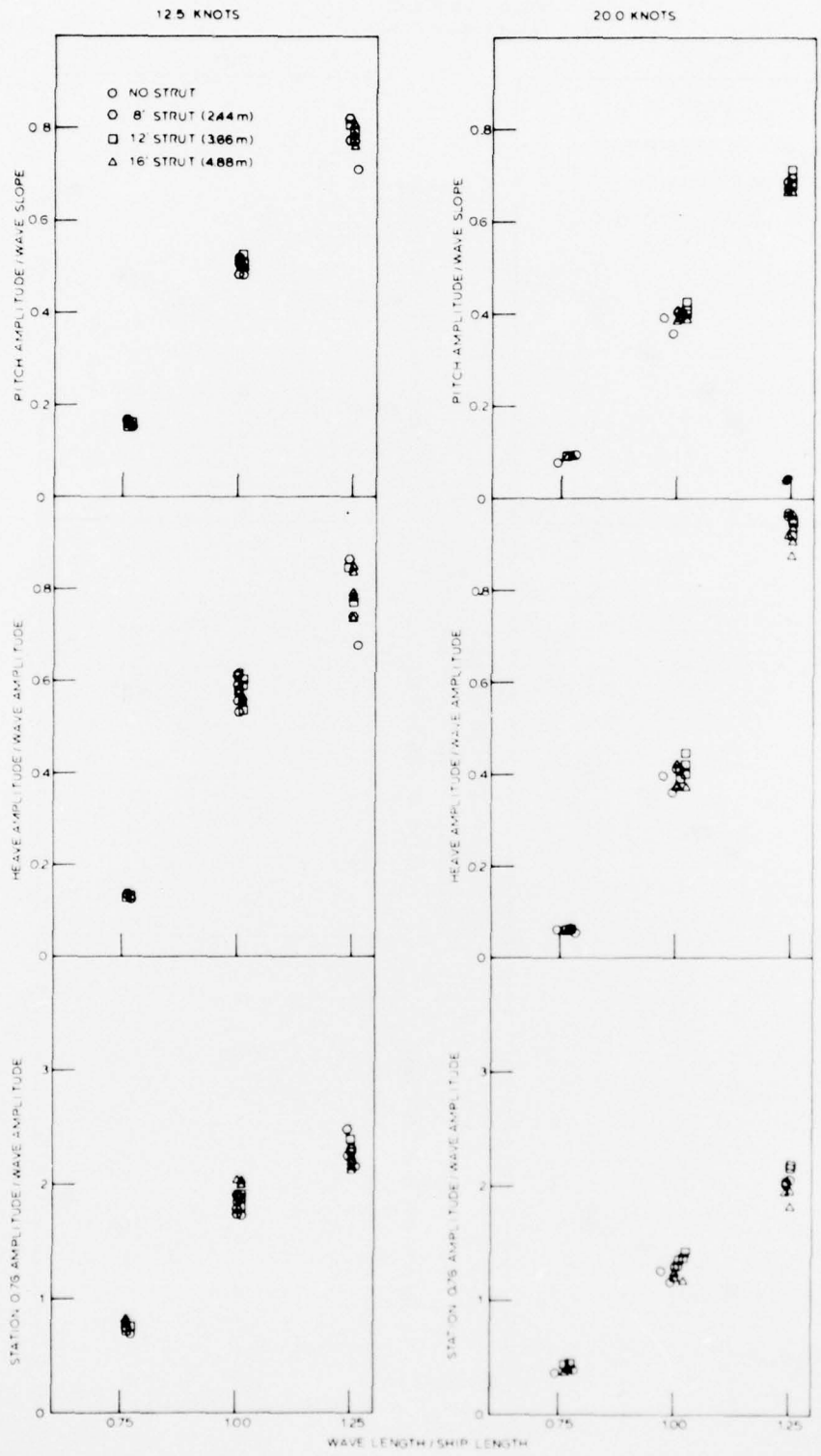

Figure 3 - Nondimensional Transfer Functions for Pitch, Heave and Acceleration (Absolute Motion) at Station 0.76 for Ship Speeds of 12.5 and 20 Knots

SHIP SPEED = 12.5 KNOTS
 WAVE LENGTH / SHIP LENGTH =

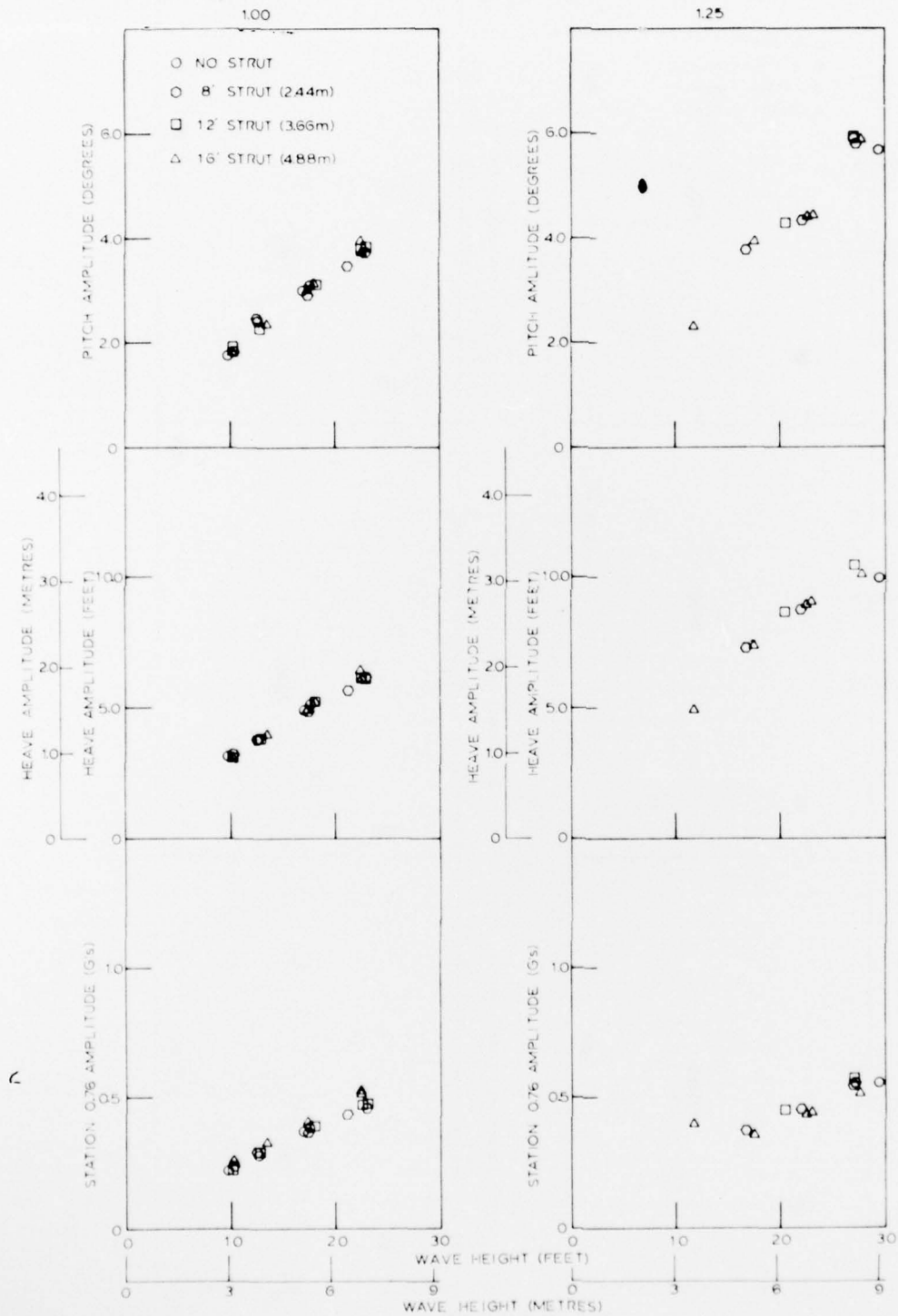

Figure 4 - Pitch, Heave, and Acceleration at Station 0.76
 Single Amplitude Values versus Wave Height for
 a Ship Speed of 12.5 Knots

SHIP SPEED • 20.0 KNOTS
 WAVE LENGTH/SHIP LENGTH •

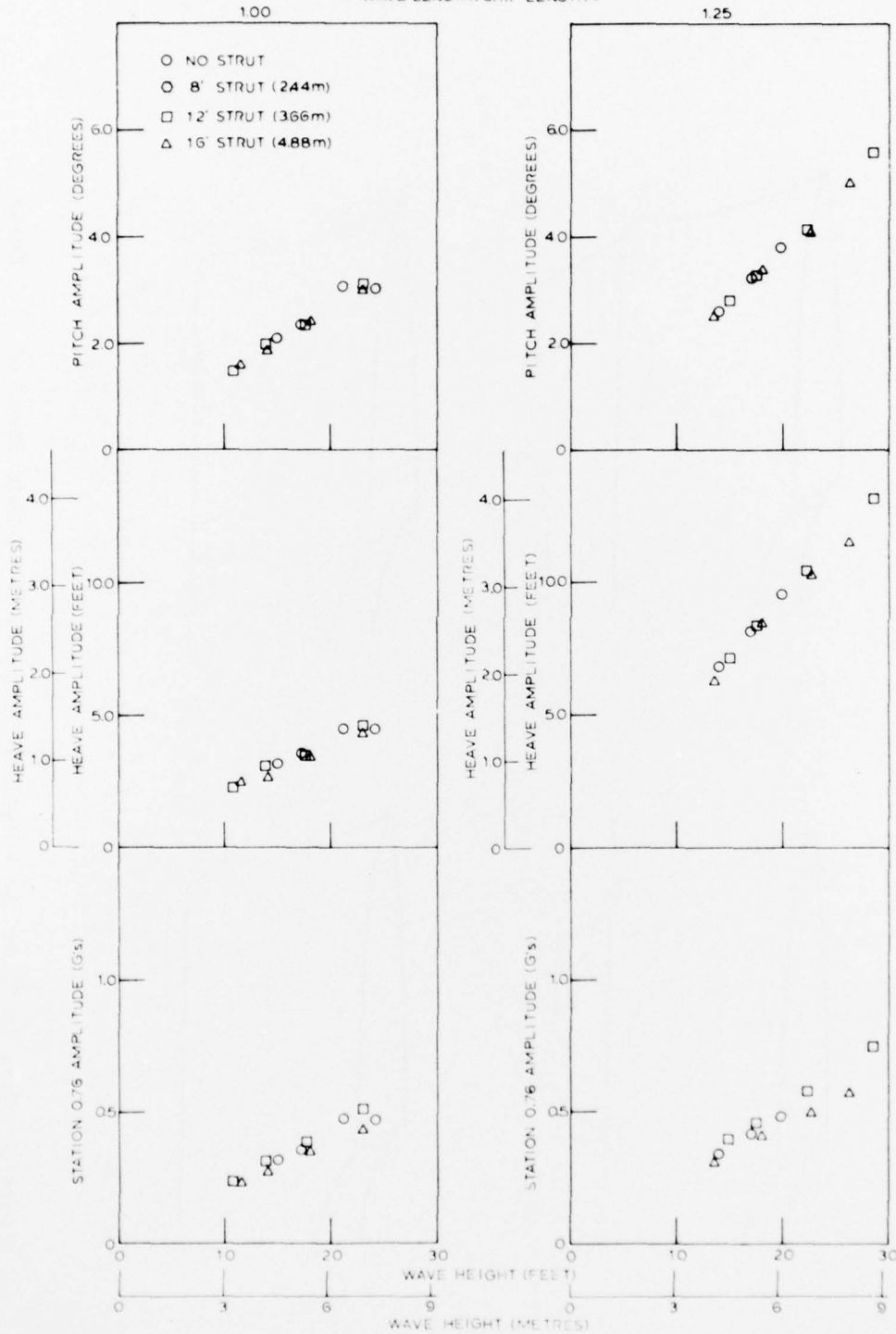

Figure 5 - Pitch, Heave, and Acceleration at Station 0.76
 Single Amplitude Values versus Wave Height for
 a Ship Speed of 20.0 Knots

SHIP SPEED = 12.5 KNOTS
WAVE LENGTH / SHIP LENGTH = 1.00
WAVE STEEPNESS = 1/30

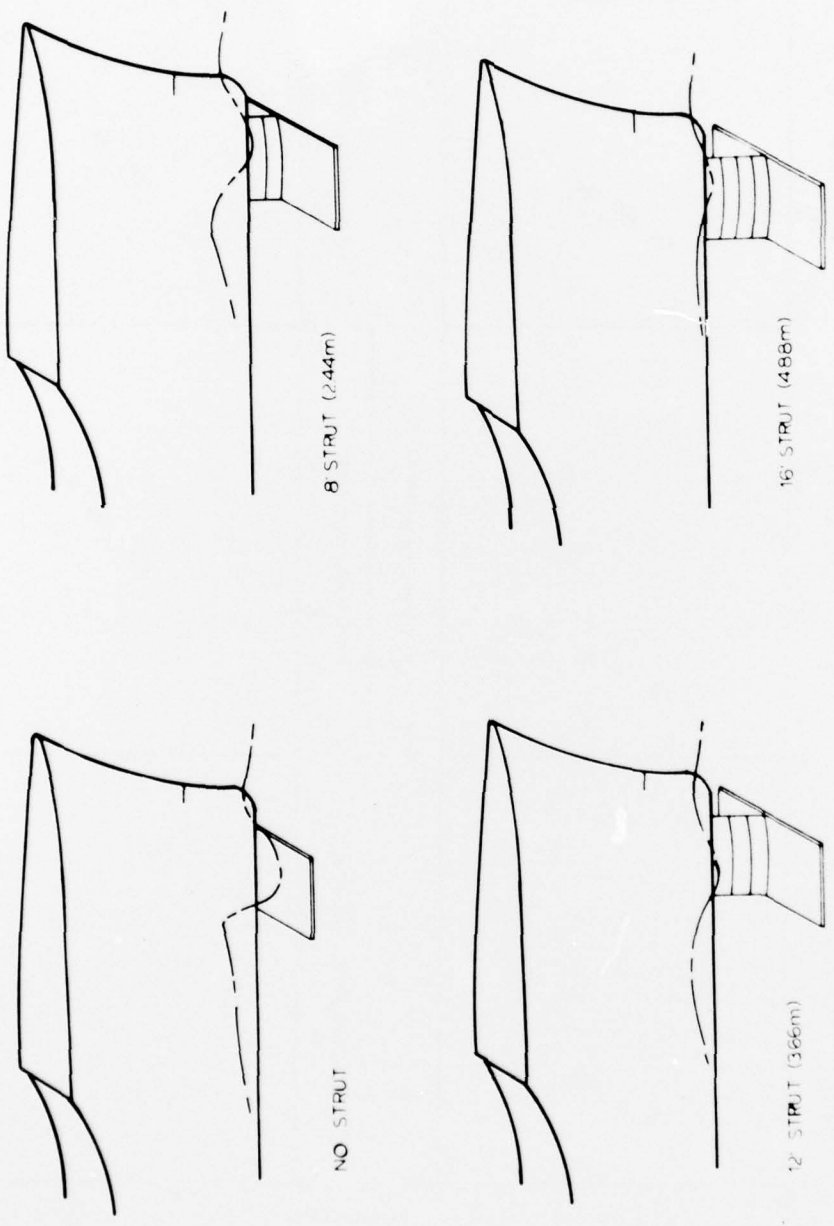

Figure 6 - Wave Profiles Above Antipitching Fin for a Ship Speed of 12.5 Knots

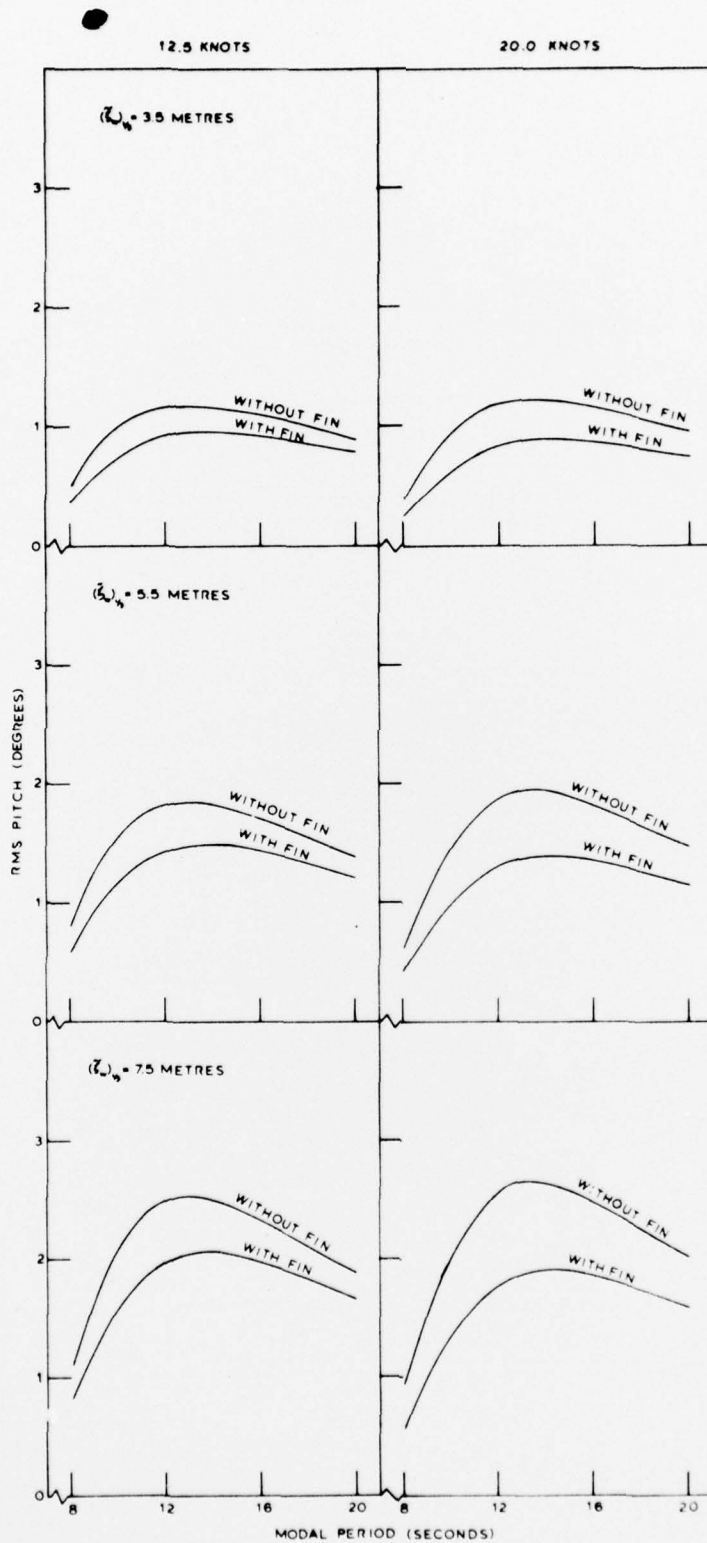

Figure 7 - Comparison of Analytical Predictions of the Pitch Motion of the Mariner with and without a Bow Fin

DTNSRDC ISSUES THREE TYPES OF REPORTS

(1) DTNSRDC REPORTS, A FORMAL SERIES PUBLISHING INFORMATION OF PERMANENT TECHNICAL VALUE, DESIGNATED BY A SERIAL REPORT NUMBER.

(2) DEPARTMENTAL REPORTS, A SEMIFORMAL SERIES, RECORDING INFORMATION OF A PRELIMINARY OR TEMPORARY NATURE, OR OF LIMITED INTEREST OR SIGNIFICANCE, CARRYING A DEPARTMENTAL ALPHANUMERIC IDENTIFICATION.

(3) TECHNICAL MEMORANDA, AN INFORMAL SERIES, USUALLY INTERNAL WORKING PAPERS OR DIRECT REPORTS TO SPONSORS, NUMBERED AS TM SERIES REPORTS, NOT FOR GENERAL DISTRIBUTION.