

AD A 039735

3

RESEARCH AND DEVELOPMENT BRANCH
DEPARTMENT OF NATIONAL DEFENCE
CANADA

DEFENCE RESEARCH ESTABLISHMENT OTTAWA

DREO TECHNICAL NOTE NO. 77-5
DREO TN 77-5

NICKEL/CADMIUM AIRCRAFT BATTERIES: MULTICHANNEL GASSING-RATE METER

by

K. Feldman and R.L. Haines

AD No. _____
DDC FILE COPY



DDC
RECEIVED
MAY 23 1977
B

PROJECT NO.
54-03-07

DISTRIBUTION STATEMENT A
Approved for public release
Distribution Unlimited

MARCH 1977
OTTAWA

RESEARCH AND DEVELOPMENT BRANCH

DEPARTMENT OF NATIONAL DEFENCE
CANADA

DEFENCE RESEARCH ESTABLISHMENT OTTAWA

TECHNICAL NOTE NO. 77-5

NICKEL/CADMIUM AIRCRAFT BATTERIES:
MULTICHANNEL GASSING-RATE METER

by

K. Feldman* and R.L. Haines
Electrical Power Sources Division

PROJECT NO.
54-03-07

RECEIVED MARCH 1977
PUBLISHED MARCH 1977
OTTAWA

* On contract from Computing Devices Company

77-078

see 1473

UNCLASSIFIED

TABLE OF CONTENTS

	Page
ABSTRACT/RESUME.....	(i)
TABLE OF CONTENTS.....	(ii)
INTRODUCTION.....	1
GENERAL DESIGN.....	2
DETAILED DESCRIPTION.....	2
Attachment to Cells.....	2
Filter Chamber and Orifice.....	6
Manometers.....	9
Interconnections.....	12
The Structure.....	13
CALIBRATION.....	13
CLEANING.....	15
ACKNOWLEDGEMENTS.....	16
REFERENCES.....	17
APPENDIX I.....	18

UNCLASSIFIED

UNCLASSIFIED

ABSTRACT

The instrument described is used to assess the state of health of separators in nickel/cadmium aircraft batteries and thus to permit removal from service of those cells which may be expected to fail catastrophically in the near future. Twenty channels are provided to permit simultaneous observation of all cells in a complete battery. Each channel measures the rate of emission of gas from one cell during overcharge by means of the pressure build up in a chamber from which the gas escapes via a suitable orifice. Construction, calibration and cleaning are discussed.

RESUME

L'appareil désigné sert à évaluer l'état des séparateurs des accumulateurs nickel/cadmium d'aéronef et sert de cette façon à éliminer les accumulateurs susceptibles de provoquer ultérieurement une défaillance majeure de la batterie. Vingt canaux permettent d'observer simultanément tous les accumulateurs d'une batterie. Chaque canal permet d'évaluer le dégagement gazeux d'un accumulateur lors d'une surcharge à l'aide de la pression formée dans une chambre de laquelle s'échappe le gaz par un orifice approprié. Sa construction, son étalonnage et son nettoyage sont discutés.

(11)

UNCLASSIFIED

ACQUISITION FOR	
NTIS	WORLD SERVICE <input checked="" type="checkbox"/>
DDIC	DDIC SERVICE <input type="checkbox"/>
UNAT/UNATB	<input type="checkbox"/>
JUSTIFICATION	
BY	
DISTRIBUTION AVAILABILITY CODES	
CLASS	APPROPRIATE SPECIAL

A

INTRODUCTION

The separator material between the positive and negative plates of nickel/cadmium aircraft batteries performs several critical functions. Two of these are of concern here. One function is to prevent oxygen, generated during overcharge at the positive plate, from reaching the negative plate. The other function is to prevent migrating metal from forming short circuiting bridges between the plates.

Partial failure in either or both of these functions permits undesirable reactions to occur. Ultimately catastrophic failure may follow. Failure conditions usually build up slowly and may therefore be detected during maintenance procedures before the danger point is reached. It has been found that separator deterioration leading to both types of failure can be detected in early stages by observing the gassing characteristics of individual cells during overcharge and on recharge after post-charge periods of open circuit stand (1).

To facilitate making the above observations the multichannel gassing-rate meter described in this paper was developed at the Defence Research Establishment Ottawa. It may be used to observe when each of the cells in a battery start to gas and subsequently to measure the rate of gassing. In the latter use, the arrangement facilitates intercomparison of the cells at a glance.

This paper gives the principles used and details of construction of the meter as built at DREO. It should be recognized that many of these details are somewhat arbitrary and are presented for illustrative purposes. Due to the nature of the environment to be expected in nickel/cadmium battery shops, materials used should be resistant to attack by potassium hydroxide, should not be inflammable, and should be reasonably robust.

A provisional parts list based on the laboratory model and given for preliminary planning purposes is given in Appendix I.

GENERAL DESIGN

Since the nickel/cadmium batteries normally used in the Canadian Forces' aircraft contain 19 cells each, the gassing rate meter provides separate channels for each, plus one spare channel for a total of 20. The indicators are manometers arranged adjacent to each other. This provides ease in comparing the gassing rates of the various cells with each other, and perhaps with a "standard" which may be connected to the 20th channel. A photograph of the unit is shown in Figure 1.

Each channel is composed of cell attachment fittings, a filter chamber, an orifice, a manometer, and interconnecting tubing. These details may be seen in the photograph of a single channel assembly shown in Figure 2. In use, the cell attachments are substituted for the vent cap normally covering the cell. Gas emitted by the cell passes through the tubing and is released near the bottom of the glass bead filter. After passing upward through the filter it escapes through the double orifice provided by the hypodermic needles which project through the rubber stopper at the top end of the filter chamber. Because of the restricted orifice, gas pressure builds up in the chamber in direct proportion to the rate of gas emission from the cell.* Tubing connects the chamber to the manometer so that the latter indicates the pressure in the chamber. A calibration scale relates the pressure to the gassing rate of the cell. For convenience, the readings are made using only one leg of the manometer.

DETAILED DESCRIPTION

ATTACHMENT TO CELLS

A diagram of attachment fittings is shown in Figure 3. The fittings provide a gas tight connection between the cell and the tubing to the meter.

* See for example, Chemical Engineers' Handbook, edited by Perry and Chilton, Published by McGraw Hill, 5th edition, pages 5-11

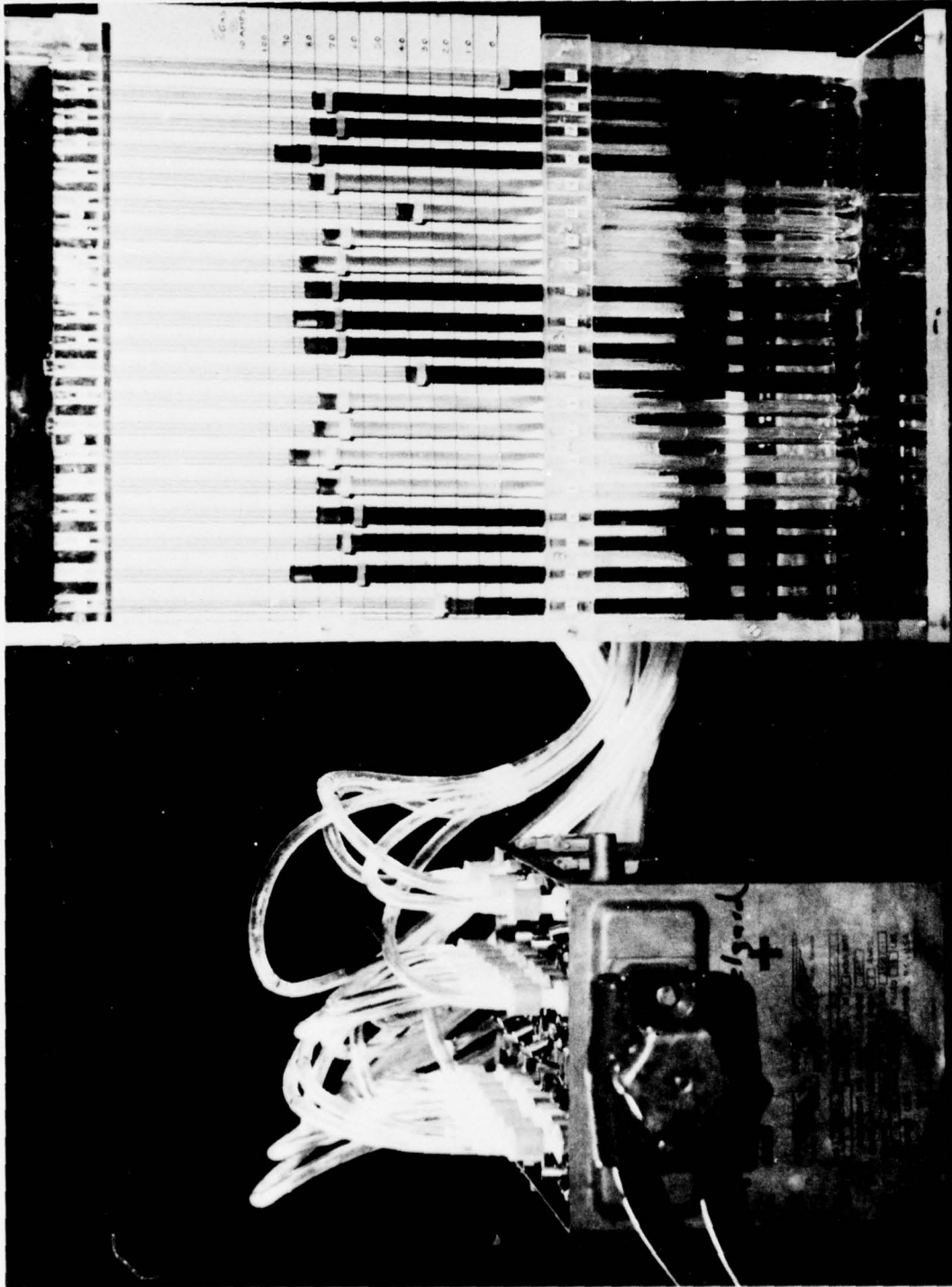

Fig. 1: Multichannel Gassing Rate Meter in Operation

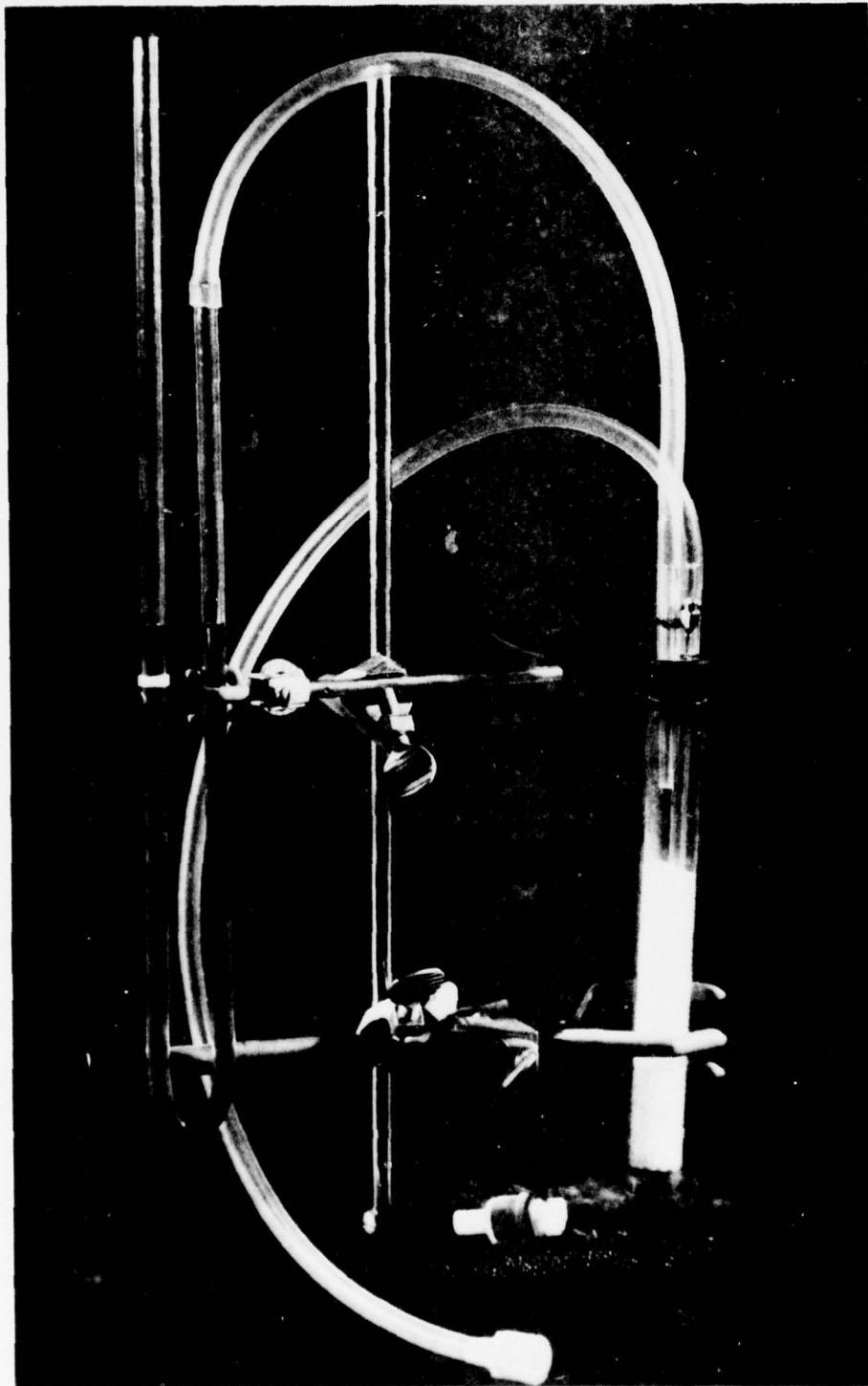

Fig. 2: The Basic Components in a Channel of the Gassing Rate Meter

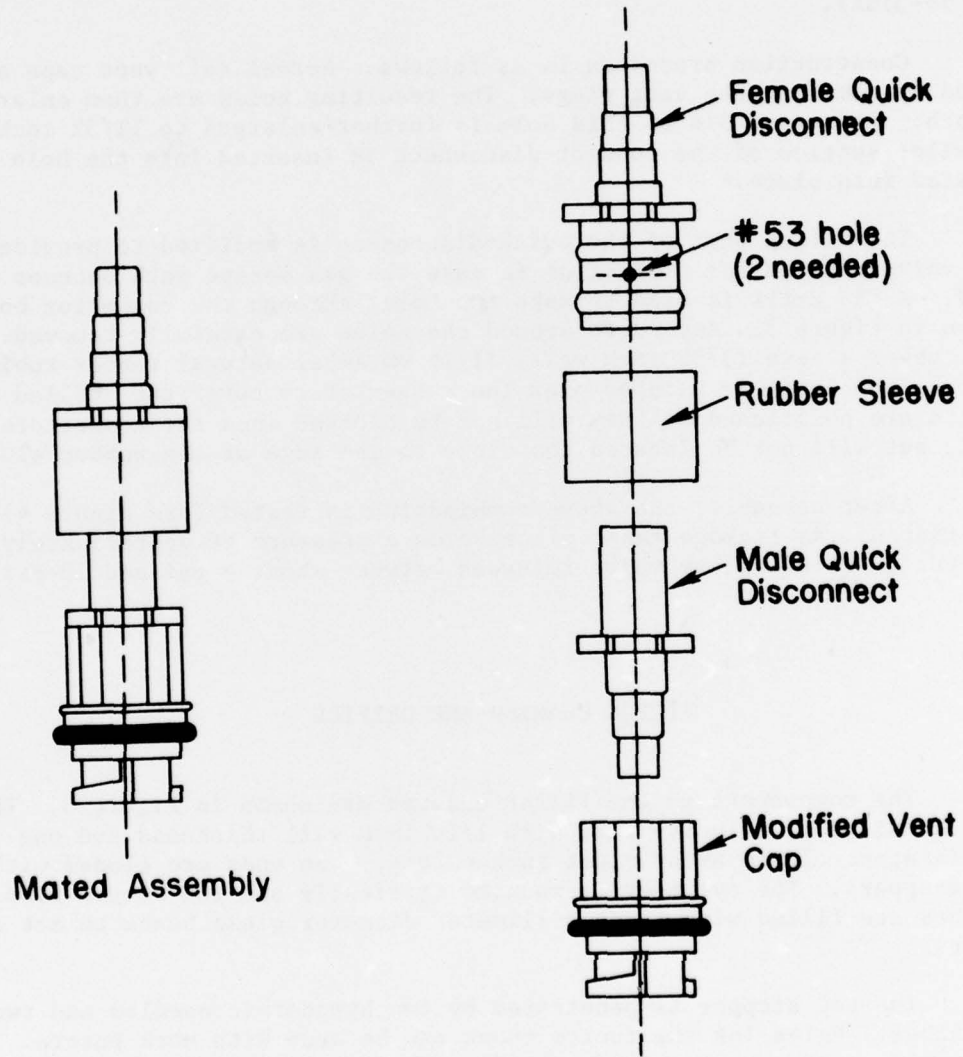

Fig. 3: Cell Attachment Fittings

They are convenient to attach and remove with normal vent cap keys, and include safety vents to avoid excessive pressure build up in the cell in the event of an accidental blockage in the system. They are made by modifying normal vent caps to accept "Nalgene Quick Disconnects" (Fisher catalogue number 15-315A).

Construction procedure is as follows. Normal cell vent caps are modified by removing the vent plugs. The resulting holes are then enlarged to $\frac{1}{4}$ inch. The upper $\frac{3}{4}$ of this hole is further enlarged to $\frac{11}{32}$ inch. The smaller section of the connect-disconnect is inserted into the hole and is epoxied into place.*

The mating part of the quick-disconnect is modified to provide the safety valve desired for protection in case the gas escape path becomes blocked. A #53 drill is used to make two holes through the connector body as shown in Figure 3. Any burrs around the holes are carefully removed. Then a rubber sleeve (3/32 inch wall, 11/16 OD Amber natural rubber tubing about 5/8 inch long) is slipped over the connector to cover the drilled holes. The holes are positioned so they will not be blocked when the connectors are engaged, but will not be located too close to the edge of the rubber sleeve.

After assembly, the above combination is tested (see Figure 4) to ensure that no gas leakage takes place below a pressure of approximately 4 psi, but that the safety valve releases between about 4 psi and 10 psi.

FILTER CHAMBER AND ORIFICE

The components in the filter chamber are shown in Figure 5. The chamber consists of a lucite tube with 1/16 inch wall thickness and one inch outer-diameter. It is about eight inches long. The ends are closed with #4 rubber stoppers. The cylinder is mounted vertically and the bottom five or six inches are filled with three millimeter diameter glass beads to act as a filter.

The top stopper is penetrated by two hypodermic needles and two lucite tubes. Holes for the lucite tubes can be made with cork borers. One of the tubes reaches to within about 1/2 inch of the bottom stopper and serves as the gas inlet. The other tube reaches only a fraction of an inch below the top stopper and is connected to the manometer to permit measurement of the pressure developed in the chamber. Both tubes are made of 1/16 inch wall thickness Lucite and have 1/4 inch outer diameters.

The hypodermic needles are identified as "local anesthesia needles (45 LNR) 22 gauge x 2 1/2 inches". They serve as a double orifice through

* The use of epoxy in the connector is not entirely satisfactory since it does not bond to the disconnects. However, the joint is usually gas proof at the pressures encountered in this application.

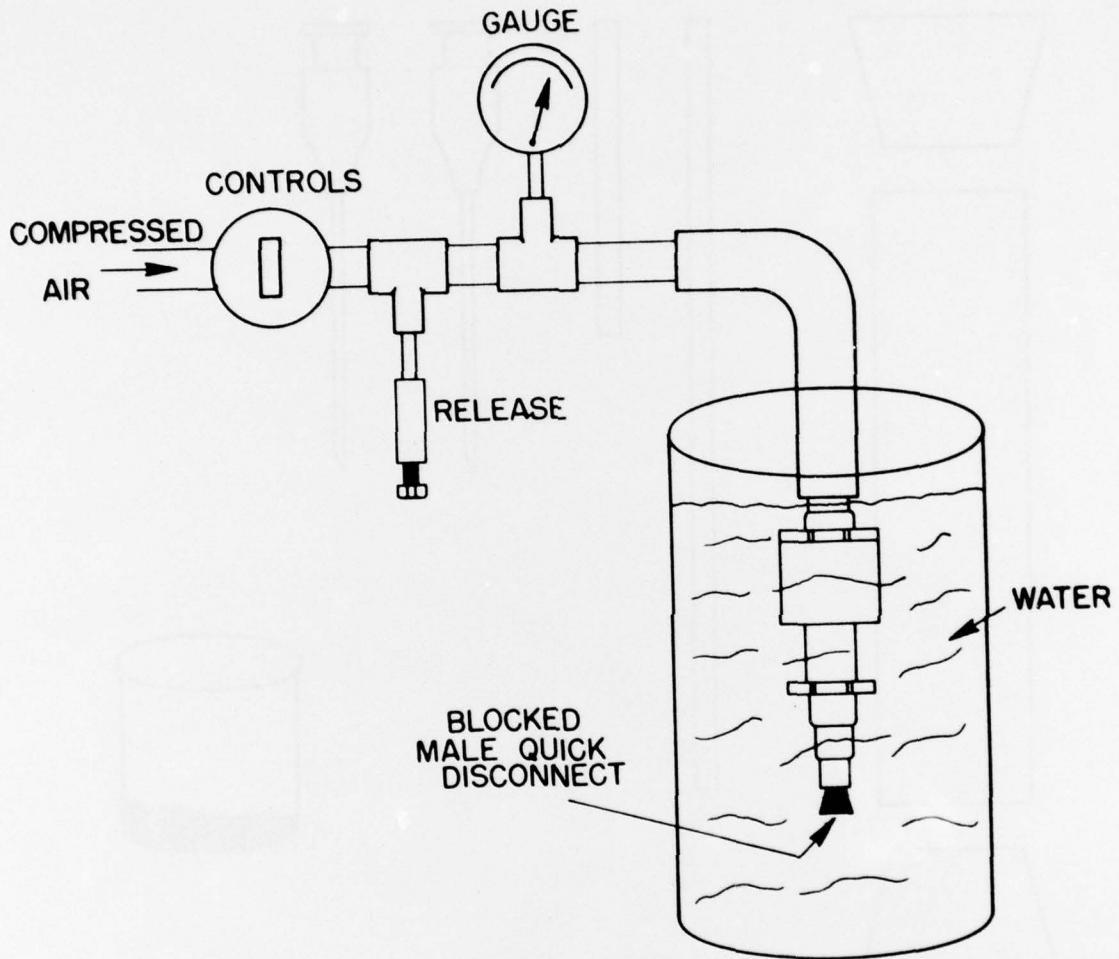

Fig. 4: Safety Valve Test

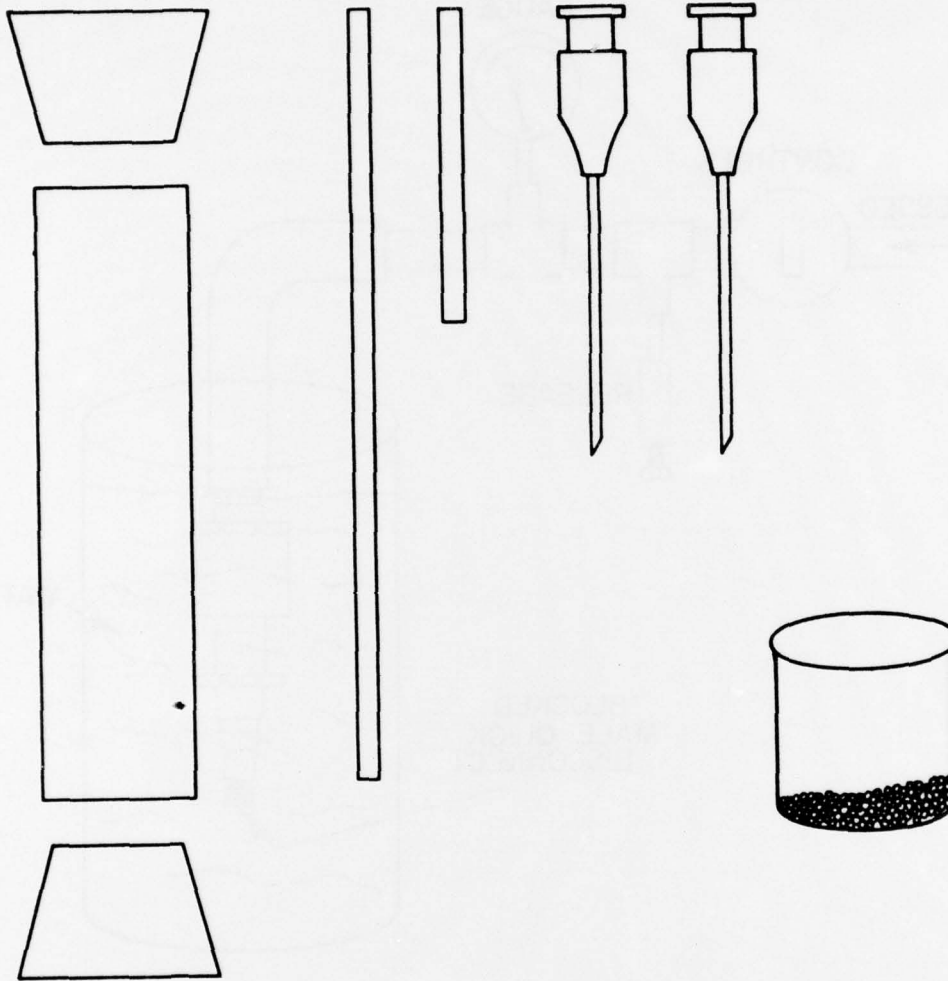

Fig. 5: Filter Chamber Components

- (a) #4 rubber stoppers
- (b) 1 inch Lucite tube, 8 in. long
- (c) 1/4 inch Lucite tube, 9 in. long
- (d) 1/4 inch Lucite tube, 3 in. long
- (e) 22 gauge hypodermic needles, 2 1/2 in. long
- (f) 3 mm glass beads

which the filtered gas escapes and therefore determine the sensitivity of the system. A fully charged cell, with perfect separator and being charged at 20 amperes, produces gas at a rate sufficient to give pressure of approximately 0.46 psi in the chamber.

The hypodermic needles may be inserted by merely forcing them through the stopper. However, this procedure requires great care to avoid bending the needles. A more satisfactory method is to first insert a more robust (17 gauge) needle in the opposite direction. The required needle is then inserted into the pointed end of the large needle. The latter is withdrawn, leaving the desired needle in place.

It was found that the hypodermic needles were not exactly identical causing variations in sensitivity from channel to channel (some obvious variations in needle length were observed). Procedures for minimizing these variations are given in the section on calibration.

MANOMETERS

The manometers are made of lucite tubes having 1/16 inch wall thickness and 1/4 inch inner diameter (smaller diameter tubes give trouble due to capillary effects and bubble entrapment). Details of the shape and dimensions are given in Figure 6. The lucite tube may readily be heated and bent but precautions are necessary to prevent the heated tube from collapsing and to avoid development of strains in the bends. The latter may result in cracks either soon after cooling or after intervals of up to several months.

One convenient method to prevent collapse at the bend is to fill the tube with table salt and stopper the ends, before heating and bending. Bends made by the following procedures were crack resistant: A jig consisting of a slotted 1/2 inch board with rounded corners in the slot and with short side guides as shown in Figure 7 is used to aid in making uniform bends. The salt filled tube of proper length is rotated over the jig by one person while another heats the tube at the desired location by use of a heat gun (such as is used for shrinking shrinkable sleeving). When the tube is heated sufficiently it softens to the point where it is unable to support the weight of the extended end. Heating is then discontinued and the tube is bent over the slot in the jig. It is held in position and allowed to cool slowly until rigid. The bend is then annealed by insertion into boiling water for about 5 minutes. To prevent any change in the bend during this treatment the U is clamped suitably. After the heating the tubes are allowed to cool slowly to room temperature.

The length of the manometer as shown in Figure 6, when used with the fluid described below and with the chamber orifice described above, is suitable for measuring gas flow rates expected when cells are charged at currents not exceeding about 35A.

The fluid used in the manometers is made up of one part water to four parts of glycerin. This mixture was chosen because it is not inflammable,

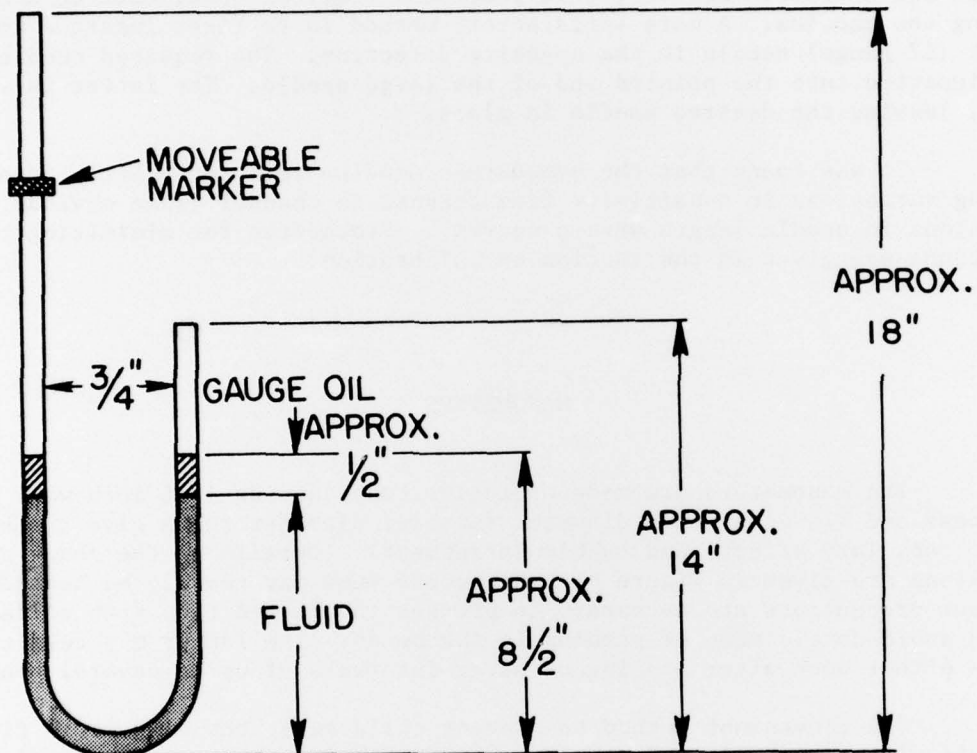

Fig. 6: Manometer Details

Tube: Lucite, 1/4" ID, 1/16" wall, Approx. 33" long
 Fluid: 1 Part Water, 3 Parts Glycerin
 Marker: High Density Polyethylene Tubing, 5/16" OD,
 1/4" long, split longitudinally

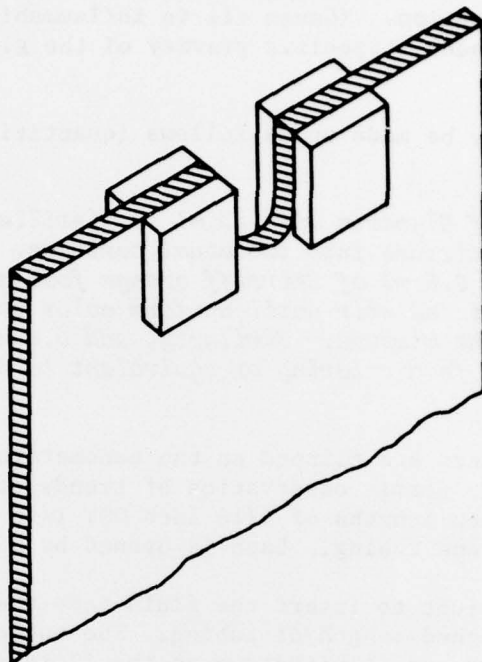

Fig. 7: Jig for Use in Bending Tubes for Manometers

has the right viscosity for this application (i.e. it is neither too sluggish nor too "splashy") and does not evaporate rapidly. In addition dyes are used to colour the fluid different colours, making adjacent groups of four the same colour. This is done to aid the operator in correlating manometer reading with cell number. Small quantities of gauge oil are added to the surface of the main fluid in both legs of each manometer to still further reduce the water evaporation. (Gauge oil is inflammable therefore only small quantities of it are used). Specific gravity of the glycerine water mixture is approximately 1.2.

The fluid may be made up as follows (quantities are suitable for one 20 channel unit):

Mix 200 ml of Glycerin with 50 ml of distilled water. Divide this mixture into two equal portions. To one of these add 0.5 ml of Shirriff orange food coloring or equivalent and stir until uniform color is obtained throughout the mixture. Similarly, add 0.5 ml of Salada Green food coloring or equivalent to the second portion.

Sliding markers are clipped on the manometers to permit rapid marking of readings, to permit observation of trends etc. The markers are made by cutting 1/4 inch lengths of 5/16 inch OD, 1/16 inch wall thickness, high density polyethylene tubing. Each is opened by a longitudinal cut.

It is convenient to insert the fluid into the manometers by use of a syringe with an attached length of tubing. The tubing is inserted to the bottom of the manometer and is withdrawn as the fluid is injected. This avoids the trapping of bubbles and wetting the upper parts of the tubes.

INTERCONNECTIONS

Gas tight connections between the cell attachment fitting and the filter chamber and between the manometer and the filter chamber are made by means of Tygon 1/4 inch ID, 3/8 inch OD tubing. A slight problem is encountered in that the manometer outside diameter is larger than the inside diameter of the tubing. This is solved by heating the end of the tubing for about a minute in boiling water and stretching it slightly by inserting long nosed pliers and opening them sufficiently. The tubing may then be forced on the manometer tube and a good seal results. Connections to the small tubes in the filter chamber are easily made but are frequently not gas tight. These connections are therefore improved by tying lacing tape tightly around them.

THE STRUCTURE

The structure carries all of the parts of the separator condition meter except the modified vent caps. It is made of lucite to give resistance to attack by electrolyte and to render various parts of the system visible for easy inspection. The basic dimensions are shown in Figure 8.

The front part of the structure is provided with a recessed portion to permit the insertion and removal of calibration charts mounted on a suitable panel. This facilitates use of appropriate calibrations for different charging rates as well as observation of the back leg of the manometer tubes if necessary.

The back panel is made detachable to facilitate the removal of individual filter chambers should this become necessary, as, for example, to clean the filter beads (if the tubing connecting the filter chamber to the manometer is long enough, the chamber may be lifted out without removing the back of the structure).

CALIBRATION

The term "calibration" is used here to imply two separate activities. One is the fine adjustment of sensitivity of the channels to get more or less uniform response from channel to channel. The other is to produce one or more scales against which to read the manometers in terms of percentage of theoretical maximum gassing-rate.

Since the sensitivity is determined by the hypodermic needle orifice, if the needles were completely uniform no differences should appear between channels. However, differences sufficiently large to attract attention sometimes do occur. These differences may be minimized by taking advantage of the double needle arrangement. A constant gas rate source such as the reference gas cell* is operated to give a gassing rate in the vicinity of full scale. This is connected to each channel in turn and the manometer height is marked with the markers. Channels giving obviously low readings are checked for leakages at the various joints.

After any leaking joints are repaired, these channels are tested again and the manometer levels are marked. Obviously high channels, if any, are then checked for needles with obstructions (wires for cleaning are normally supplied with the needles).

* A cell similar to the nickel/cadmium vented cell except that all of plates consist of sheets of stainless steel.

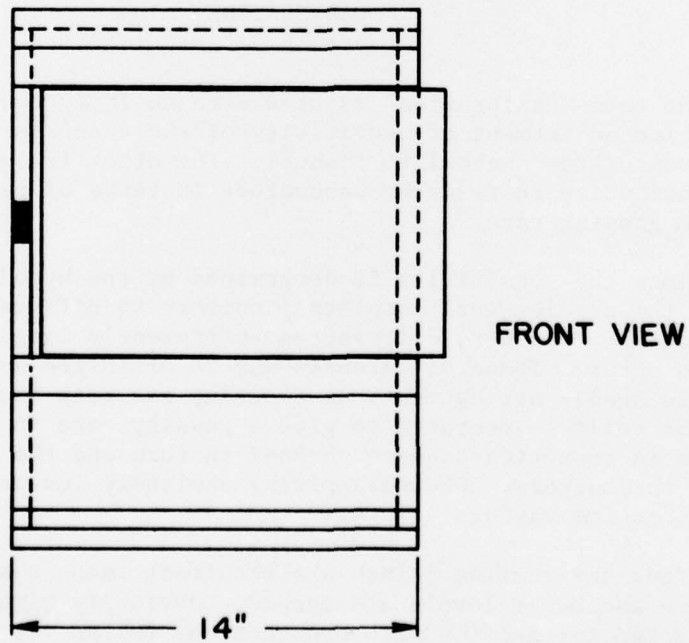
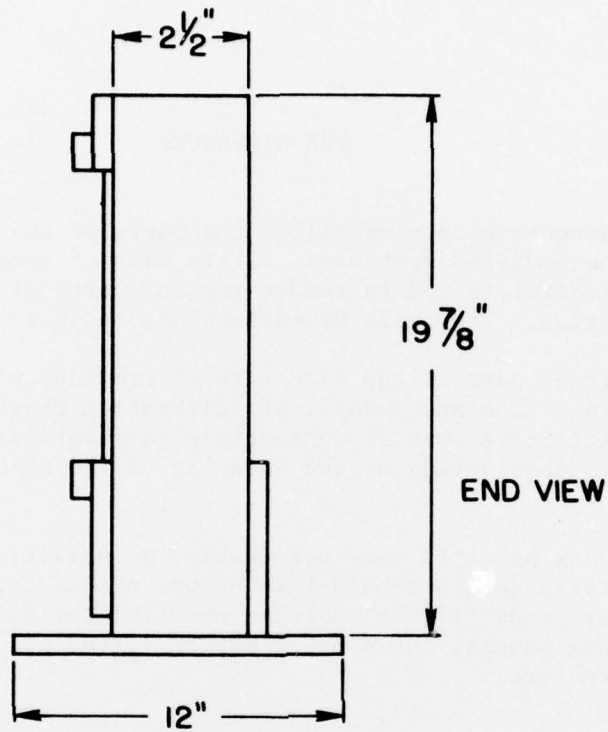

Fig. 8: The Basic Structure

If some channels now give higher and lower levels than the majority, the deviations are minimized as follows. The gassing rate from the source is adjusted to about one-half its previous value. Needles in the offending channels are then blocked off, one at a time, and the resulting manometer readings are noted and recorded if necessary. This makes it possible to list needles which give high readings and needles which give low readings. Single needles are then switched between channels to alter the sensitivity in the desired direction (for instance if it is found that one channel has two needles which both tend to give high readings, one of these is exchanged with a needle from a channel where both needles tended to give low readings). Occasionally a needle must be discarded and a new one used in its place.

Construction of a reading scale is fairly simple if the reference gas cell or other source of known gas flow is available. A suitable sheet of paper or other material (supported on cardboard etc. if necessary) is slipped into the recess behind the front legs of the manometers (see section on "The Structure"). One channel is connected to the gas flow source flowing at the rate selected as the 100% base (assumed to be 16 A in the unit described here). The manometer level attained is marked on the scale. The material may then be removed from the structure and a horizontal line is drawn through the marked point. Since the needed scale is linear, other lines as desired may be computed and drawn.

CLEANING

Cleaning may occasionally become necessary. This applies particularly to the attachment fittings which may become blocked with carbonate or other materials. Such material is usually readily soluble in water so periodic rinsing in a container of water is normally sufficient. This may be done without detaching those components which are fastened to the tubing.

If a significant amount of liquid collects in the filter chamber this should be emptied, and the beads should be washed in distilled water and replaced. This may be done by first lifting each chamber out of its compartment (removal of the back panel of the structure may be necessary or convenient), and removing the bottom stopper. The beads may be caught in a container and washed. When the beads are relatively dry they may be poured back into the chamber by tilting the bottom of the chamber upward and using a suitable funnel. The bottom of the funnel stem should reach beyond the opening of the gas entry tube to avoid beads being trapped in the tube. To avoid the same problem with the tube leading to the manometer, a suitable wire may be inserted into this tube through the bottom of the chamber before the funnel is put in place. When the beads have been inserted and the funnel removed, the cylinder may be held in a nearly horizontal position while the wire is slowly withdrawn and the stopper replaced.

An important cleaning task may arise if the hypodermic needles become partly blocked. This causes the readings given during use of the channel to be higher than normal and may be readily identified by interchanging channels on a given cell and comparing the readings (or by using a reference

UNCLASSIFIED

cell and a known charge current). The hypodermic needles are normally supplied with cleaning wires which may be inserted several times to dislodge blockages. It may also be advisable to periodically clean the needles by using a syringe to force distilled water through them.

ACKNOWLEDGEMENTS

The contributions of Messrs P. Willis, R. Schupe, B. Valiquette, and G. Brown in overcoming technical problems are gratefully acknowledged.

UNCLASSIFIED

REFERENCES

1. K. Feldman, R.L. Haines and R. Hayashi, Nickel/Cadmium Aircraft Batteries: Failure Prediction in Battery Shops by Gassing Rate Measurements, DREO Technical Note No. 76-12. A brief version of this paper was also released as DREO Report No. 739 for presentation at the 27th Power Sources Symposium, Atlantic City, New Jersey, 21-24 June, 1976.

APPENDIX I

PROVISIONAL PARTS LIST*

1.	Nalgene Quick Disconnects (Fisher #15-315A).....	20 only
2.	Ni/Cd cell vent caps with rubber rings.....	20 only
3.	Hypodermic Needles (45 LNR) 22 gauge x 2 1/2 inches.....	40 only
4.	Glass Beads, 3 mm diameter (Fisher #11-312A).....	3 1/2 lb.
5.	Rubber Stoppers, #4.....	40 only
6.	Glycerine.....	1 pint
7.	Lucite Tube, 1" O.D., 1/16" wall thickness.....	18 ft.
8.	Lucite Tube, 1/4" O.D., 1/16" wall thickness.....	24 ft.
9.	Lucite Tube, 3/8" O.D., 1/16" wall thickness.....	60 ft.
10.	Gauge Oil.....	1 oz.
11.	Rubber Tubing, 11/16" O.D., 3/32" wall thickness, Amber Natural Rubber.....	2 ft.
12.	Tygon Tubing, 3/8" O.D., 1/16" wall thickness, Amber Natural Rubber.....	80 ft.
13.	Lucite Sheet, 1/2" thick..... Approx.....	2 ft x 4 ft
14.	Lucite Sheet, 1/4" thick..... Approx.....	1 ft x 2 ft
15.	Lucite Sheet, 1/8" thick..... Approx.....	1 ft x 2 ft
16.	High Density Polyethylene tubing 5/16" O.D.....	1 ft.
17.	Shirrif Orange food color (available in food stores).....	0.5 ml
18.	Salada Green food color (available in food stores).....	0.5 ml

* This list is provided for preliminary planning purposes. It is based on a laboratory model and items 13 to 15 inclusive are approximate only. Details relating to the construction of the laboratory model are presented for illustrative purposes.

UNCLASSIFIED

Security Classification

DOCUMENT CONTROL DATA - R & D		
(Security classification of title, body of abstract and indexing annotation must be entered when the overall document is classified)		
1. ORIGINATING ACTIVITY Defence Research Establishment Ottawa National Defence Headquarters Ottawa K1A 0Z4		2a. DOCUMENT SECURITY CLASSIFICATION UNCLASSIFIED
		2b. GROUP N/A
3. DOCUMENT TITLE Nickel/Cadmium Aircraft Batteries: Multichannel Gassing-Rate Meter		
4. DESCRIPTIVE NOTES (Type of report and inclusive dates) TECHNICAL NOTE		
5. AUTHOR(S) (Last name, first name, middle initial) Keiva / FELDMAN, Ronald L. / Keiva and HAINES, Ronald L.		
6. DOCUMENT DATE 11 MARCH 1977	7a. TOTAL NO. OF PAGES 18	7b. NO. OF REFS 1
8a. PROJECT OR GRANT NO. 54-03-07	9a. ORIGINATOR'S DOCUMENT NUMBER(S) DREO TECHNICAL NOTE NO. 77-5	
8b. CONTRACT NO.	9b. OTHER DOCUMENT NO.(S) (Any other numbers that may be assigned this document)	
10. DISTRIBUTION STATEMENT UNLIMITED DISTRIBUTION		
14 DREO-TN-77-5		
11. SUPPLEMENTARY NOTES	12. SPONSORING ACTIVITY DAASE	
13. ABSTRACT The instrument described is used to assess the state of health of separators in nickel/cadmium aircraft batteries and thus to permit removal from service of those cells which may be expected to fail catastrophically in the near future. Twenty channels are provided to permit simultaneous observation of all cells in a complete battery. Each channel measures the rate of emission of gas from one cell during overcharge by means of the pressure build up in a chamber from which the gas escapes via a suitable orifice. Construction, calibration and cleaning are discussed.		

(UNCLASSIFIED)

404576 JB

UNCLASSIFIED

Security Classification

KEY WORDS

GASSING RATE METER
MULTICHANNEL METER
NICKEL/CADMIUM BATTERIES
SEPARATOR HEALTH

INSTRUCTIONS

1. **ORIGINATING ACTIVITY:** Enter the name and address of the organization issuing the document.
- 2a. **DOCUMENT SECURITY CLASSIFICATION:** Enter the overall security classification of the document including special warning terms whenever applicable.
- 2b. **GROUP:** Enter security reclassification group number. The three groups are defined in Appendix M of the DRB Security Regulations.
3. **DOCUMENT TITLE:** Enter the complete document title in all capital letters. Titles in all cases should be unclassified. If a sufficiently descriptive title cannot be selected without classification, show title classification with the usual one-capital-letter abbreviation in parentheses immediately following the title.
4. **DESCRIPTIVE NOTES:** Enter the category of document, e.g. technical report, technical note or technical letter. If appropriate, enter the type of document, e.g. interim, progress, summary, annual or final. Give the inclusive dates when a specific reporting period is covered.
5. **AUTHOR(S):** Enter the name(s) of author(s) as shown on or in the document. Enter last name, first name, middle initial. If military, show rank. The name of the principal author is an absolute minimum requirement.
6. **DOCUMENT DATE:** Enter the date (month, year) of Establishment approval for publication of the document.
- 7a. **TOTAL NUMBER OF PAGES:** The total page count should follow normal pagination procedures, i.e., enter the number of pages containing information.
- 7b. **NUMBER OF REFERENCES:** Enter the total number of references cited in the document.
- 8a. **PROJECT OR GRANT NUMBER:** If appropriate, enter the applicable research and development project or grant number under which the document was written.
- 8b. **CONTRACT NUMBER:** If appropriate, enter the applicable number under which the document was written.
- 9a. **ORIGINATOR'S DOCUMENT NUMBER(S):** Enter the official document number by which the document will be identified and controlled by the originating activity. This number must be unique to this document.
- 9b. **OTHER DOCUMENT NUMBER(S):** If the document has been assigned any other document numbers (either by the originator or by the sponsor), also enter this number(s).
10. **DISTRIBUTION STATEMENT:** Enter any limitations on further dissemination of the document, other than those imposed by security classification, using standard statements such as:
 - (1) "Qualified requesters may obtain copies of this document from their defence documentation center."
 - (2) "Announcement and dissemination of this document is not authorized without prior approval from originating activity."
11. **SUPPLEMENTARY NOTES:** Use for additional explanatory notes.
12. **SPONSORING ACTIVITY:** Enter the name of the departmental project office or laboratory sponsoring the research and development. Include address.
13. **ABSTRACT:** Enter an abstract giving a brief and factual summary of the document, even though it may also appear elsewhere in the body of the document itself. It is highly desirable that the abstract of classified documents be unclassified. Each paragraph of the abstract shall end with an indication of the security classification of the information in the paragraph (unless the document itself is unclassified) represented as (TS), (S), (C), (R), or (U).

The length of the abstract should be limited to 20 single-spaced standard typewritten lines, 7½ inches long.
14. **KEY WORDS:** Key words are technically meaningful terms or short phrases that characterize a document and could be helpful in cataloging the document. Key words should be selected so that no security classification is required. Identifiers, such as equipment model designation, trade name, military project code name, geographic location, may be used as key words but will be followed by an indication of technical context.