

AD-A039 959

TECHNICAL  
LIBRARY

AD-A039 959



AMMRC CTR 77-8

**FABRICATION OF DISCONTINUOUS GRAPHITE-ALUMINUM  
COMPOSITES VIA PULTRUSION**

**FEBRUARY 1977**

**H. Gigerenzer, G. C. Strempek  
FIBER MATERIALS, INC.  
Biddeford Industrial Park, Biddeford, Maine 04005**

**FINAL REPORT**

**Contract Number DAAG46-76-C-0068**

Approved for public release; distribution unlimited.

**Prepared for**

**ARMY MATERIALS AND MECHANICS RESEARCH CENTER  
Watertown, Massachusetts 02172**

The findings in this report are not to be construed as an official Department of the Army position, unless so designated by other authorized documents.

Mention of any trade names or manufacturers in this report shall not be construed as advertising nor as an official indorsement or approval of such products or companies by the United States Government.

**DISPOSITION INSTRUCTIONS**

**Destroy this report when it is no longer needed.  
Do not return it to the originator.**

## TABLE OF CONTENTS

<u>Section</u>	<u>Page</u>
FOREWORD . . . . .	i
1.0 OBJECTIVE . . . . .	1
2.0 SUMMARY . . . . .	1
3.0 TECHNICAL APPROACH . . . . .	3
3.1 Introduction . . . . .	3
3.2 Graphite-Aluminum Preforms . . . . .	5
3.3 Pultrusion Concept . . . . .	8
4.0 DETAILS OF PULTRUSION FABRICATION . . . . .	9
4.1 Process Description . . . . .	9
4.2 Lay-up . . . . .	14
4.3 Pultrusion Process Parameters . . . . .	16
5.0 RESULTS OF HOT WORKING GRAPHITE-ALUMINUM COMPOSITES BY PULTRUSION . . . . .	16
5.1 Preliminary Pultrusion Trials . . . . .	19
5.2 Pultrusion and Mechanical Testing of T300 G/6061 Al and T300 G/356 Al Round Bars . . . . .	22
5.3 Pultrusion of T300 G/6061 Al Rectangular Bars . . . . .	29
6.0 DISCUSSION . . . . .	31
7.0 CONCLUSIONS . . . . .	36
8.0 RECOMMENDATIONS FOR FUTURE WORK . . . . .	37

## LIST OF FIGURES

<u>Figure</u>	<u>Page</u>
1. Typical Stress-Strain Behavior of PAN Based Graphite-Aluminum Composite Wire Preforms . . . . .	7
2. Working End of Modified 10 Ton Pull Capacity Draw Bench Used for Pultrusion of Graphite-Aluminum Composites . . . . .	10
3. Sectional View of Pultrusion Process Setup . . . . .	11
4. Die Extension With Billet Assembly in Place . . . . .	12
5. Section of Pultruded Graphite-Aluminum Bar Stock Processed in the Solid State (15% Billet Reduction) . . . . .	13
6. Assembly of Pultrusion Billet . . . . .	15
7. Billet Assembly that Failed During Pultrusion Due to Non-Uniform Deformation Caused by Excessive Reduction (40%) . . . . .	20
8. Section of Pultruded Graphite-Aluminum Bar Stock Processed in the Solid State at a Billet Reduction of 30% Where Composite has Fractured into Segments Due to Exceeding Hot Workability . . . . .	21
9. Tensile Specimen Configuration . . . . .	23
10. Graphite-Aluminum Tensile Specimen . . . . .	24
11. Graphite-Aluminum Tensile Specimen after Testing Showing Manner of Failure . . . . .	24
12. Typical Stress-Strain Behavior of T300 G/6061 Al Pultruded Composite Bar Stock . . . . .	25
13. Typical Stress-Strain Behavior of T300 G/356 Al Pultruded Composite Bar Stock . . . . .	26
14. Transverse Flexure Specimen Configuration . . . . .	28
15. As Pultruded Rectangular Section Bar Showing Twist Along Bar Axis . . . . .	30
16. Split Rectangular Section after Solution and Quench Cycle . . . . .	32
17. Typical Transverse Microstructures of Pultruded Graphite-Aluminum Round Bar Stock Processed in the Solid State . . . . .	33
18. Longitudinal Microstructure of Pultruded Graphite-Aluminum Round Bar Stock Processed in the Solid State . . . . .	34

LIST OF TABLES

<u>Table</u>		<u>Page</u>
1.	Composite Matrix Compositions . . . . .	6
2.	Preliminary Pultrusion Trials for Graphite-Aluminum Rounds (940 <sup>o</sup> F) . . . . .	17
3.	Mechanical Properties of Pultruded Graphite-Aluminum Bars (Solid State Processed at 940 <sup>o</sup> F) . . . . .	18

## FOREWORD

This work is being performed by Fiber Materials, Inc., Biddeford, Maine for the Army Materials and Mechanics Research Center, Watertown, Massachusetts under Contract DAAG46-76-C-0068. The Army Technical Supervisor is Mr. Jacob Greenspan. The FMI Program Manager is Mr. Horst Gigerenzer with Mr. Gary C. Strempek assisting as Project Engineer.

UNCLASSIFIED

SECURITY CLASSIFICATION OF THIS PAGE (When Data Entered)

REPORT DOCUMENTATION PAGE		READ INSTRUCTIONS BEFORE COMPLETING FORM
1. REPORT NUMBER AMMRC CTR 77-8	2. GOVT ACCESSION NO.	3. RECIPIENT'S CATALOG NUMBER
4. TITLE (and Subtitle) Fabrication of Discontinuous Graphite-Aluminum Composites via Pultrusion		5. TYPE OF REPORT & PERIOD COVERED Final Report
		6. PERFORMING ORG. REPORT NUMBER
7. AUTHOR(s) H. Gigerenzer and G.C. Strempek		8. CONTRACT OR GRANT NUMBER(s) DAAG46-76-C-0068
9. PERFORMING ORGANIZATION NAME AND ADDRESS Fiber Materials Incorporated Biddeford Industrial Park Biddeford, Maine 04005		10. PROGRAM ELEMENT, PROJECT, TASK AREA & WORK UNIT NUMBERS D/A Project: ITI63102D071 AMCMS Code: 613102.12.15900 Agency Accession: DA OF 4782
11. CONTROLLING OFFICE NAME AND ADDRESS Army Materials and Mechanics Research Center Watertown, Massachusetts 02172		12. REPORT DATE February 1977
		13. NUMBER OF PAGES
14. MONITORING AGENCY NAME & ADDRESS (if different from Controlling Office)		15. SECURITY CLASS. (of this report) Unclassified
		15a. DECLASSIFICATION/DOWNGRADING SCHEDULE ---
16. DISTRIBUTION STATEMENT (of this Report)  Approved for public release; distribution unlimited.		
17. DISTRIBUTION STATEMENT (of the abstract entered in Block 20, if different from Report)		
18. SUPPLEMENTARY NOTES		
19. KEY WORDS (Continue on reverse side if necessary and identify by block number)  Aluminum graphite composites Fabrication Pultrusion process		
20. ABSTRACT (Continue on reverse side if necessary and identify by block number)  The objective of the program was to produce high strength graphite-aluminum composite bars of round and rectangular cross-sections via a pultrusion process, with the resulting composite structure consisting of discontinuous graphite fibers in an aluminum matrix. Graphite-aluminum composite wire preforms were produced using a liquid metal infiltration process. Continuous Thornel 300 polyacrylonitrile (PAN) based graphite fiber tows were infiltrated with both 6061 and 356 aluminum alloy melts.		

Graphite-aluminum composite preform properties of 18-20 msi modulus and 150-190 ksi UTS at approximately 35-40 volume percent fibers were obtained. The graphite-aluminum composite wire preforms were assembled to form a billet, in Inconel containment, and pultruded through predetermined die sizes to achieve desired composite bar consolidations of 5, 10, and 15 percent cross-sectional area reductions. Initially, round bars of nominal dimensions .5" diameter x 12" in length were fabricated. Tensile testing of specimens machined from pultruded round bar stock of these graphite-aluminum composites showed moduli in range of 16-20 msi and longitudinal strengths of 104,000 psi to 134,000 psi. Transverse strength determinations in flexure on rectangular coupons were conducted for T300 G/6061 Al for both as pultruded and heat treated conditions. Results indicated that consistently higher transverse strength values (range of 6500-8500 psi) are obtained for the composite when in the heat treated condition. The longitudinal tensile strengths were not affected by heat treatment. Pultrusion processing of rectangular cross-sections (nominal dimension .75" x .18" x 12") resulted in well-consolidated bars. All bars fabricated, however, exhibited a twist along the axis of the bar length. Heat treatment (during solution and quench cycle) of four bars resulted in splitting of three bars. Due to the process difficulties encountered, suitable specimens from the rectangular sections were not obtained for mechanical testing. Metallographic examination of sections from pultruded bar stock showed the hot worked graphite-aluminum composites to consist of areas containing many discontinuous fiber segments. No voids or separation defects at the broken fiber ends were evident upon examining the microstructure, indicating that matrix flow occurs around the broken fiber ends, thus healing defects during pultrusion processing. It was concluded that thermal-mechanical working (up to 15% RA) of graphite-aluminum fiber composites by pultrusion has been successfully demonstrated and that this processing technique has potential for the fabrication of complex structural sections with minimum degradation of composite properties.

## 1.0 OBJECTIVE

The objective of the program was to produce high strength graphite-aluminum composite bars of round and rectangular cross-sections via a pultrusion process, with the resulting composite structure consisting of discontinuous graphite fibers in an aluminum matrix.

## 2.0 SUMMARY

It was concluded that thermal-mechanical working (up to 15% RA) of graphite-aluminum fiber composites by pultrusion has been successfully demonstrated and that this processing technique has potential for the fabrication of complex structural sections without degradation of composite properties.

Graphite-aluminum composite wire preforms were produced using FMI's liquid metal infiltration process. Continuous Thorne1 300 polyacrylonitrile (PAN) based graphite fiber tows were infiltrated with both 6061 and 356 aluminum alloy melts. Graphite-aluminum composite wire preform properties of 18-20 msi modulus and 185-190 ksi UTS at approximately 40 volume percent fibers were obtained. The graphite-aluminum composite wire preforms were assembled to form a billet, in Inconel containment, and pultruded through predetermined die sizes to achieve desired composite bar consolidations of 5, 10, and 15 percent cross-sectional area reductions. For property comparison, both T300 G/356 Al and T300 G/6061 Al were consolidated in the solid state at a pultrusion rate of 2.5 in./sec. Initially, round bars of nominal dimensions .5" diameter x 12" in length were fabricated.

Tensile testing of specimens machined from round bar stock of each graphite-aluminum composite system showed moduli in the range of 16-20 msi and longitudinal strengths in excess of 100,000 psi for all pultruded bars,

with the lower percent reductions for both composite systems, yielding the higher tensile strength values. The T300 G/6061 Al showed higher strength values (up to 134,000 psi) at all reductions than did the T300 G/356 Al composite. The composite moduli were also generally higher (18-20 msi range) for T300 G/6061 Al. Transverse strength determinations in flexure on 40 v/o fiber T300 G/6061 Al rectangular coupons, machined from pultruded round bars, yielded an average value of 6083 psi (range 3900-8600 psi) at bar consolidations of 5% reduction in area. Based on these results, the T300 G/6061 Al system was selected for further fabrication investigations.

An attempt to improve transverse strength by addition of aluminum to the composite was made by infiltrating and combining three strands of graphite (instead of the previously single strand fiber tow) resulting in a lower volume percent (35 v/o fiber) graphite-aluminum wire preform. These preforms had an average tensile strength of 150,000 psi and a modulus of 18-20 msi. The preforms were pultruded into round bars as before and heat treated to a standard T6-6061 Al condition. Transverse strength determinations in flexure on rectangular coupons were conducted for both as pultruded and pultruded/T6 heat treated conditions. Results indicated that more consistent transverse strength values are obtained for the T300 G/6061 Al composite when in the T6 heat treated condition (7300 psi average). The longitudinal tensile strengths for pultruded bars in both material conditions were 111,000 psi with a modulus of 18 msi. Six 12" long round sections were fabricated and delivered to AMMRC.

Pultrusion processing of T300 G/6061 Al rectangular cross-sections (nominal dimension .75" x .18" x 12") utilizing the 35 v/o fiber composite wire preform resulted in six well-consolidated bars. All bars fabricated, however, exhibited a twist along the axis of the bar length. Attempts to

straighten one bar by hot forming at 950<sup>0</sup>F partially corrected this condition; however, micro cracks were evident upon examination of both ends of the bars. Therefore, no further attempts were made to straighten remaining bars. Heat treatment of four bars resulted in splitting (during solution and quench cycle) of three bars. The aging treatment was completed on these bars. Due to the process difficulties encountered, suitable specimens from the rectangular sections were not obtained for mechanical testing.

Metallographic examination of sections from pultruded bar stock showed the hot worked composites to consist of areas containing many discontinuous fiber segments. No voids or separation defects at the broken fiber ends were evident upon examining the microstructure, indicating that matrix flow occurs around the broken fiber ends, thus healing defects during pultrusion processing.

### 3.0 TECHNICAL APPROACH

#### 3.1 Introduction

To fabricate high strength graphite-aluminum bar stock, an essential first step is the preparation of strong graphite-aluminum wire preforms which is determined by the coating treatment the graphite fibers receive prior to infiltration by liquid metal, to establish strong fiber/matrix interfaces in the composite structure.

FMI uses a modified liquid metal infiltration process for impregnating PAN graphite fiber yarns with commercial aluminum alloys. The liquid metal infiltration process involves the use of very small concentrations of titanium and boron to promote the wetting of graphite fibers by aluminum alloys. The graphite fibers are coated with a layer of Ti/B between 100 and 200 angstrom units thick to promote wetting and to protect them from attack

by the liquid metal. The titanium and boron are deposited on the fibers by the reduction of titanium tetrachloride and boron trichloride using zinc vapor, the zinc being continually extracted from the coating step of the process as zinc chloride gas. The coated fibers are infiltrated by the drawing of fibers through a molten aluminum alloy bath producing a unidirectional graphite-aluminum composite wire. These graphite-aluminum composite wires are the preforms used for consolidation into bulk graphite-aluminum, by several fabrication processes (i.e., pultrusion of preforms into bar stock).

Prior to 1976, rayon based graphite fibers were used almost exclusively in the development of graphite-aluminum composites. Rule-of-mixture tensile strengths and elastic modulus have been attained utilizing a variety of aluminum alloys with these fibers. Previous work using polyacrylonitrile (PAN) based graphite fibers in metal matrices had shown PAN based graphite to be more reactive with liquid aluminum than with rayon based graphite fibers. Therefore, poor translation of fiber strength and elastic modulus resulted in the composite. During the past year, however, a significant advance has been made at FMI in research and development on PAN graphite fiber reinforced aluminum composites. New fiber barrier coatings have been developed and demonstrated which prevent attack and degradation of the fibers by aluminum alloys during liquid metal infiltration and subsequent fabrication of composite wire preforms into shapes. PAN based graphite-aluminum composite strengths have exceeded rule-of-mixture values and are attributed to good fiber/matrix interface bonding. This new coating technology is of particular necessity for successful thermal-mechanical processing resulting in discontinuous graphite fiber aluminum composites where high interface strengths are

required to effectively utilize short fiber lengths. The concept of hot working continuous graphite fiber aluminum composite wire preforms, into high strength discontinuous graphite-aluminum consolidated bars by pultrusion, critically depends on the successful maintenance of a strong fiber to matrix bond when the fiber reinforcement is in the discontinuous processed state. The extensive work on barrier coatings and interface bonding developed at FMI for PAN based fibers was applied in the present program towards the successful pultrusion processing of discontinuous graphite fiber composites.

### 3.2 Graphite-Aluminum Preforms

Thorne1 300 PAN based graphite fiber was selected for use in the program due to its suitability (i.e., increased strength, high elongation to failure, and toughness) for hot working continuous graphite-aluminum into discontinuous composites by pultrusion.

The PAN based T300 fiber being utilized in the graphite-aluminum preforms is a 6000 filament (single strand) tow, high strain-to-failure (1.1%) graphite fiber with a tensile strength of 360 ksi and a modulus of 34 msi. These fiber tows were combined with a matrix of 6061 Al (a commercial wrought alloy with a hot working range of 500-950<sup>0</sup>F) and a commercial casting alloy, 356 Al. Alloy compositions are shown in Table 1. Figure 1 illustrates representative stress-strain behavior of T300 G/6061 Al and T300 G/356 Al wire preforms used in this program to fabricate pultruded bar stock for initial evaluation. The stress-strain behavior of the T300 G/356 Al and the T300 G/6061 Al wire preforms are similar and show the typical characteristic deviation from linear behavior exhibited by PAN based graphite-aluminum composites prior to failure. The T300 G/356 Al composite preform at 40 volume percent fiber has a total strain-to-failure of 1.2%, an initial high primary

Table 1

## COMPOSITE MATRIX COMPOSITIONS

Element	Matrix Designation	
	356 Al Casting Alloy (w/o)	6061 Al Wrought Alloy (w/o)
Mg	0.30	1.00
Si	7.00	0.60
Cu	0.20 max.	0.25
Cr	---	0.25
Fe	0.60 max.	0.70 max.
Mn	0.10 max.	0.15 max.
Zn	0.10 max.	0.25 max.
Ti	0.20 max.	0.15 max.
Others	0.10 max.	0.15 max.
Al	Balance	Balance

Figure 1  
 TYPICAL STRESS-STRAIN BEHAVIOR OF PAN BASED GRAPHITE-ALUMINUM  
 COMPOSITE WIRE PREFORMS

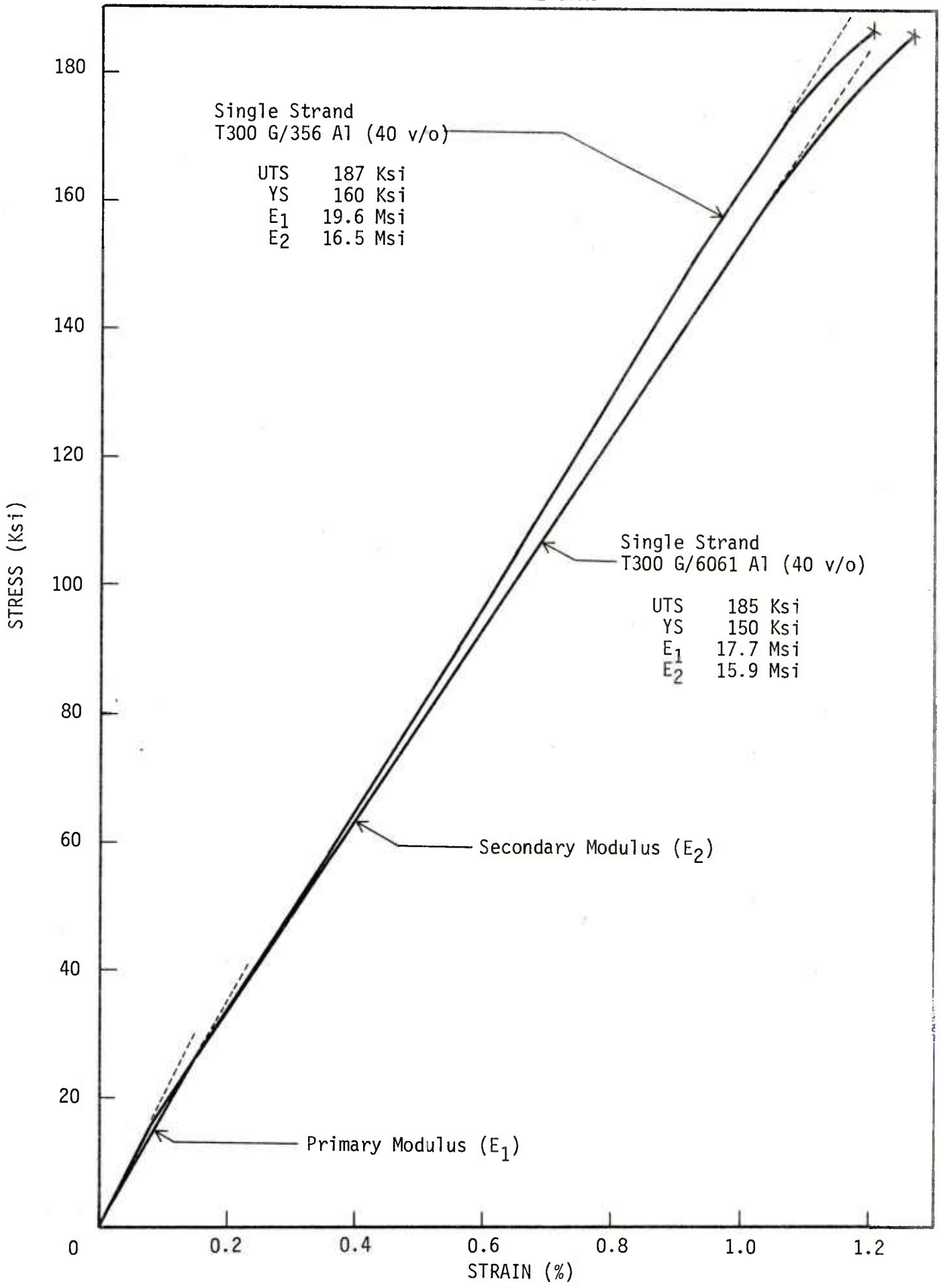

elastic modulus (typically 18-20 msi) with a transition to a lower secondary modulus (typically 15-17 msi) and a tensile strength of 187,000 psi. The T300 G/6061 Al composite preforms also at 40 volume percent fiber exhibit similar properties (see Figure 1). These preforms were used during initial bar fabrication investigations. A modified graphite-aluminum wire preform (for reasons discussed in Section 5.2) consisting of three fiber strands instead of a single strand was used for final bar fabrication. These preforms were as above except the volume percent fiber was 35 v/o instead of 40 v/o resulting in an average preform tensile strength of 150,000 psi and a modulus of 18-20 msi.

### 3.3 Pultrusion Concept

The pultrusion process differs from other hot working techniques in that consolidation of the fibers and matrix occurs with considerably less overall matrix deformation and fiber damage. The low strengths observed in past attempts at hot working T50 (rayon based) graphite-aluminum composites (for instance, by extrusion) are thought to occur primarily because the fiber/matrix bond of the composite has been damaged to the point where only limited load transfer from the matrix to the fiber can be achieved and because the fibers are degraded by notching of their surfaces. During pultrusion, however, the fibers are loaded mainly in tension, the direction of maximum fiber strength. Therefore, little fiber surface damage and interface debonding occurs during the consolidation process, since buckling stresses along the fiber/matrix interface are minimized. In addition, the manner of loading during consolidation is of primary importance when the end result is to be a discontinuous composite. Pultrusion aligns fiber fragments axially and, due to hydrostatic consolidation forces, matrix material flows into voids created when fiber ends separate. Also, the past use

of low strain-to-failure (.5% max.) T50 rayon based graphite fiber reinforcements resulted in excessive fiber damage (leading to low composite strengths). The tougher T300 PAN fiber allows controlled fiber fragmentation during hot working, thus maintaining high strength and stiffness in the worked discontinuous composite.

#### 4.0 DETAILS OF PULTRUSION FABRICATION

##### 4.1 Process Description

A 10 ton pull capacity draw bench (Figure 2), converted to enable the hot working of graphite-aluminum composites, is being used for the studies throughout the program. The pultrusion equipment has the capacity for consolidating round cross-sections two inches in diameter down to sizes of the order of 0.01" in diameter. Modifications to enable hot working of graphite-aluminum composites include a controlled, constant temperature, two-zone furnace with a maximum temperature capability of 1205°C, die extension with holder and cooling jacket, mechanical vacuum pump, and instrumentation. The die extension is preheated to the process temperature, and the assembled graphite-aluminum billet in Inconel containment is inserted. A general view of the process setup is shown in Figure 3. Once in position, the billet is evacuated (vacuum pressure  $\sim 0.1$  Torr) and then allowed to heat up to the processing temperature along with the die. Location of the billet with furnace retracted is depicted in Figure 4. It remains at temperature for approximately 30 minutes to allow outgassing of volatiles in the container. The billet is then pultruded at a rate of 2.5 in./sec. The consolidated billet is cooled and two axial cuts are made 180° apart through the container wall, freeing the composite bar. A six inch section of a T300 G/356 Al round bar consolidated by pultrusion is shown in Figure 5.

WORKING END OF MODIFIED 10 TON PULL CAPACITY DRAW BENCH USED FOR PULTRUSION OF

GRAPHITE-ALUMINUM COMPOSITES

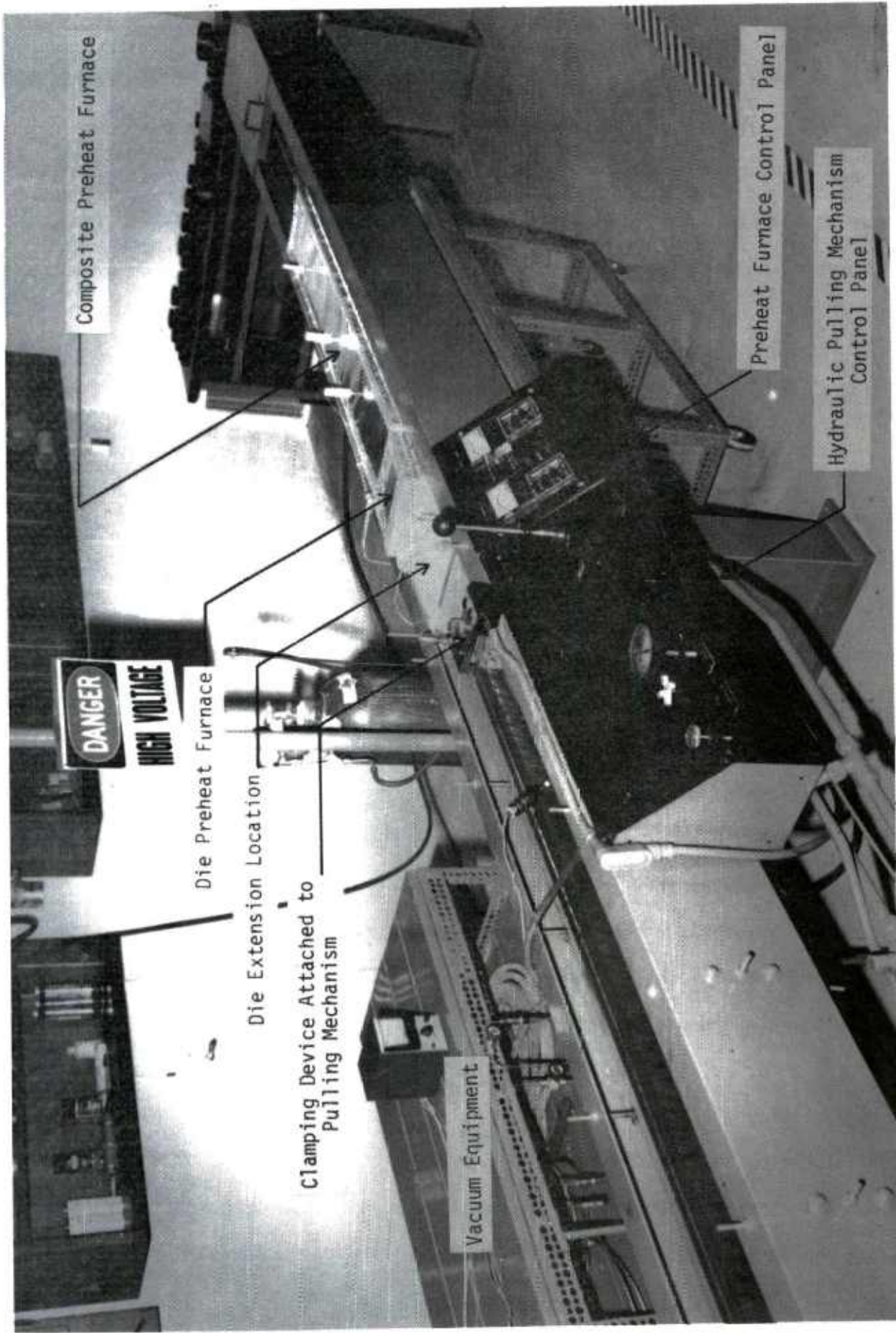

Figure 2

SECTIONAL VIEW OF PULTRUSION PROCESS SET-UP

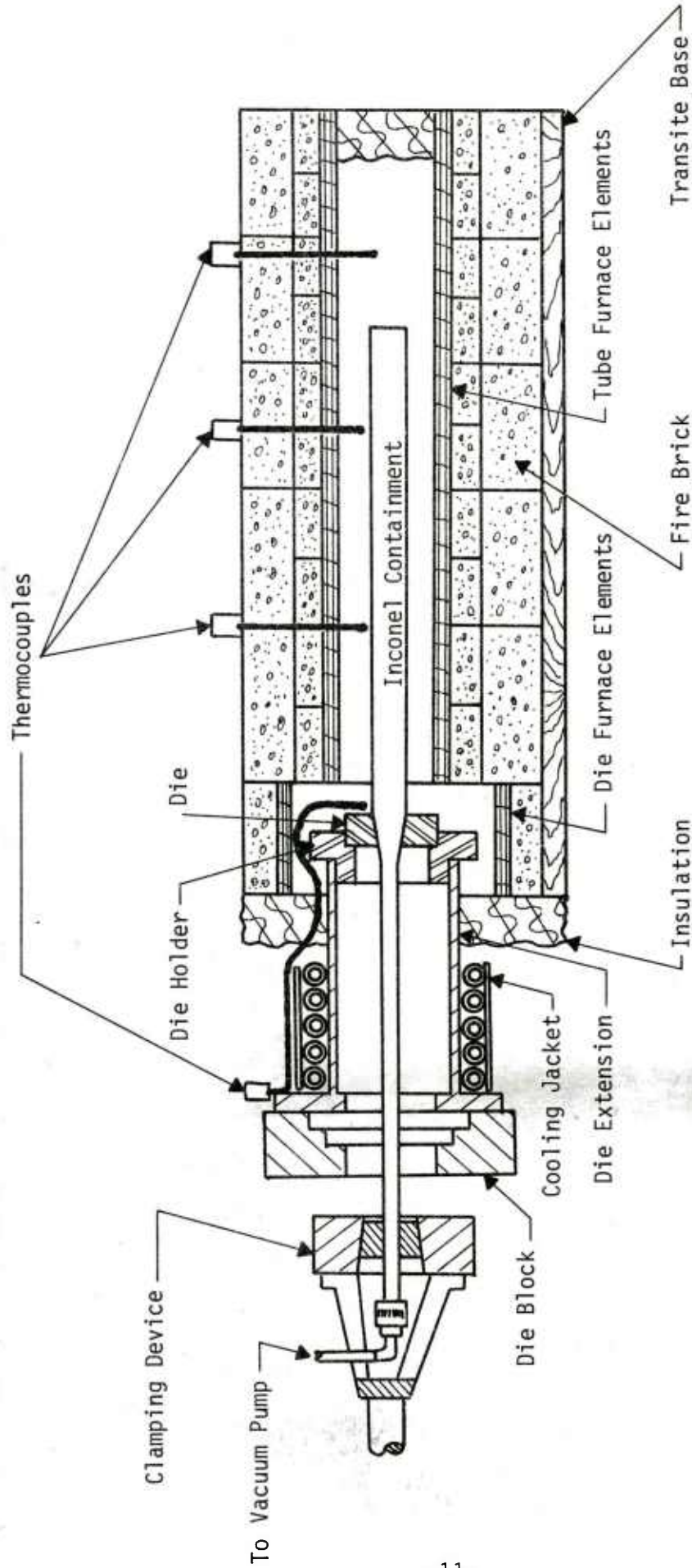

Figure 3

DIE EXTENSION WITH BILLET ASSEMBLY IN PLACE

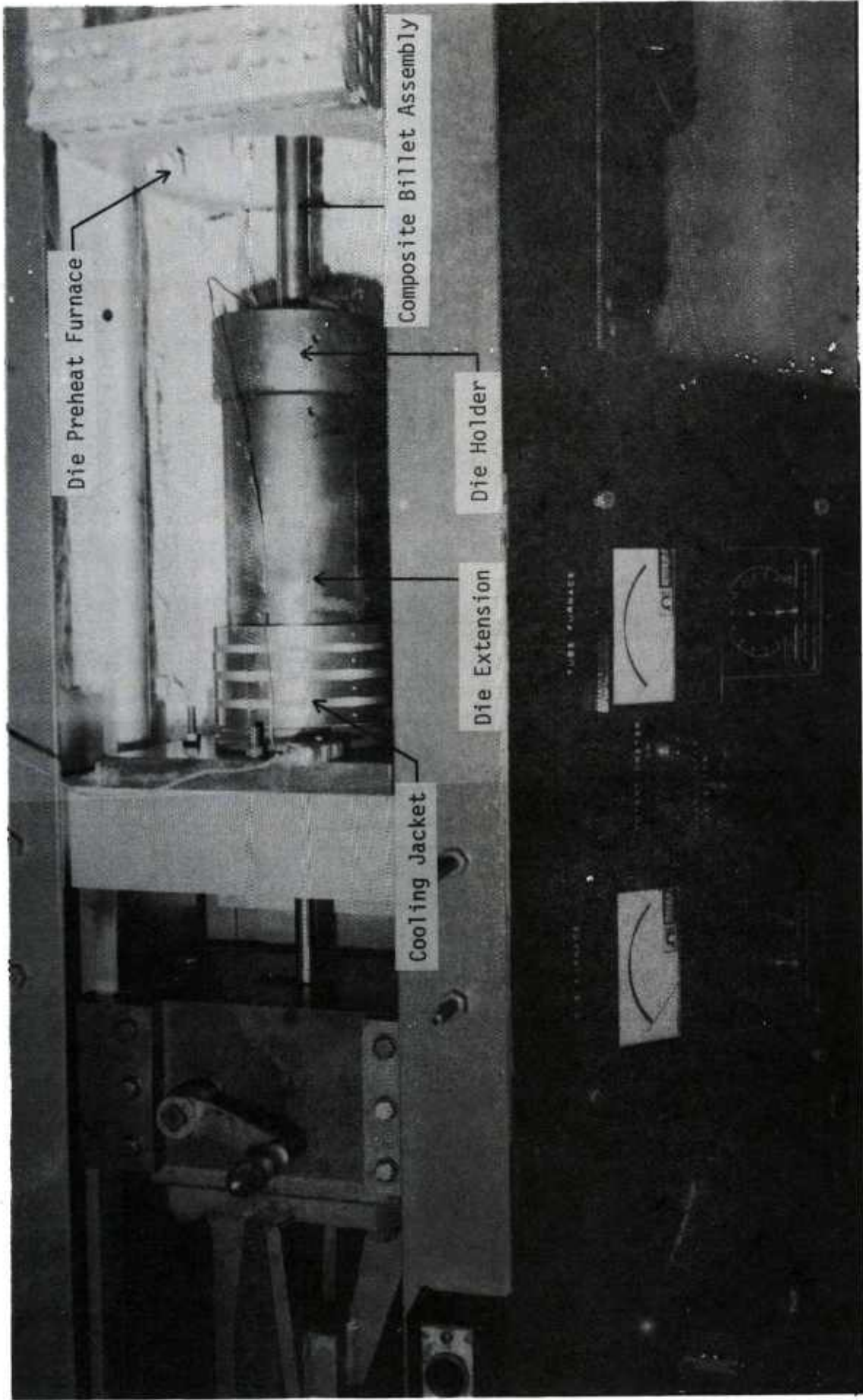

Figure 4

SECTION OF PULTRUDED GRAPHITE-ALUMINUM BAR STOCK PROCESSED IN THE SOLID STATE  
(15% Billet Reduction)

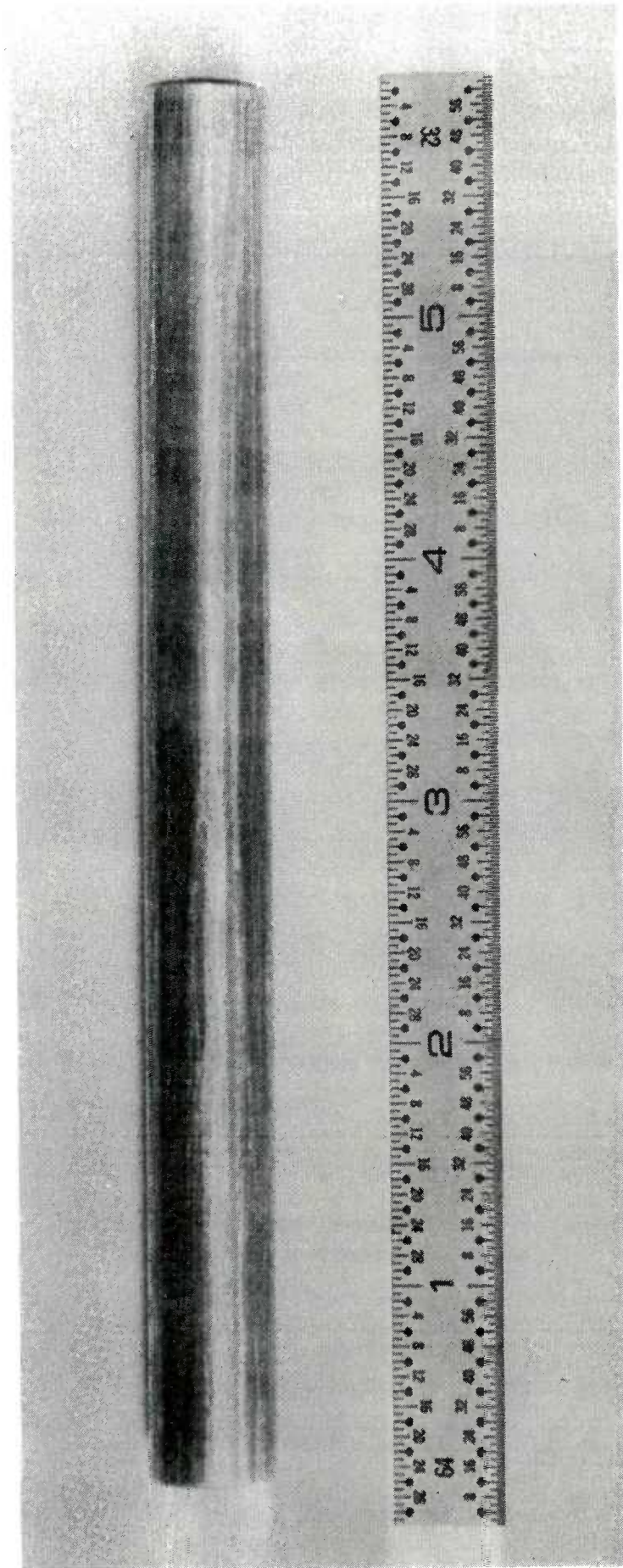

Figure 5

## 4.2 Lay-Up

The number of graphite-aluminum composite wire preforms to effect consolidation is calculated for a given percent reduction. It is determined by dividing the desired consolidated cross-sectional area of the composite bar by the average cross-sectional area of the wire preform used. For example, using a die diameter of 0.525" and Inconel containment of 0.035" thick wall, a composite bar cross-sectional area is calculated of 0.17 in.<sup>2</sup> which is divided by the average wire cross-sectional area ( $\sim .001$  in.<sup>2</sup>), resulting in a base number of 170 pieces of graphite-aluminum wire for consolidation. The desired percent area reduction (i.e., percent hot working) for the bar is determined by addition of required extra number of graphite-aluminum wires above the 170 pieces needed for full consolidation. For reductions ranging between 0 and 10%, a combination of 0.525" diameter die and 3/4" OD x 0.035" wall Inconel containment is used. On initial trial reductions of 10 to 40%, a 0.650" diameter die and 1" OD x 0.065" wall Inconel container was used. Due to irregularities in cross-sectional areas of the wire preforms, once the calculated total number of wires to form a billet was determined for a given reduction, the wires were weighed to allow reproducibility for future runs (i.e., amount of graphite-aluminum material needed was based on weight rather than on number). This eliminates errors that may otherwise result by using a specific number of wires of irregular cross-section.

The weighed graphite-aluminum wire preforms are cleaned in an ultrasonic acetone bath, wrapped in three layers of .001" thick aluminum foil to form the graphite-aluminum assembled bar, and inserted in the Inconel containment (Figure 6). The containment has a swaged leader (approximately

ASSEMBLY OF PULTRUSION BILLET

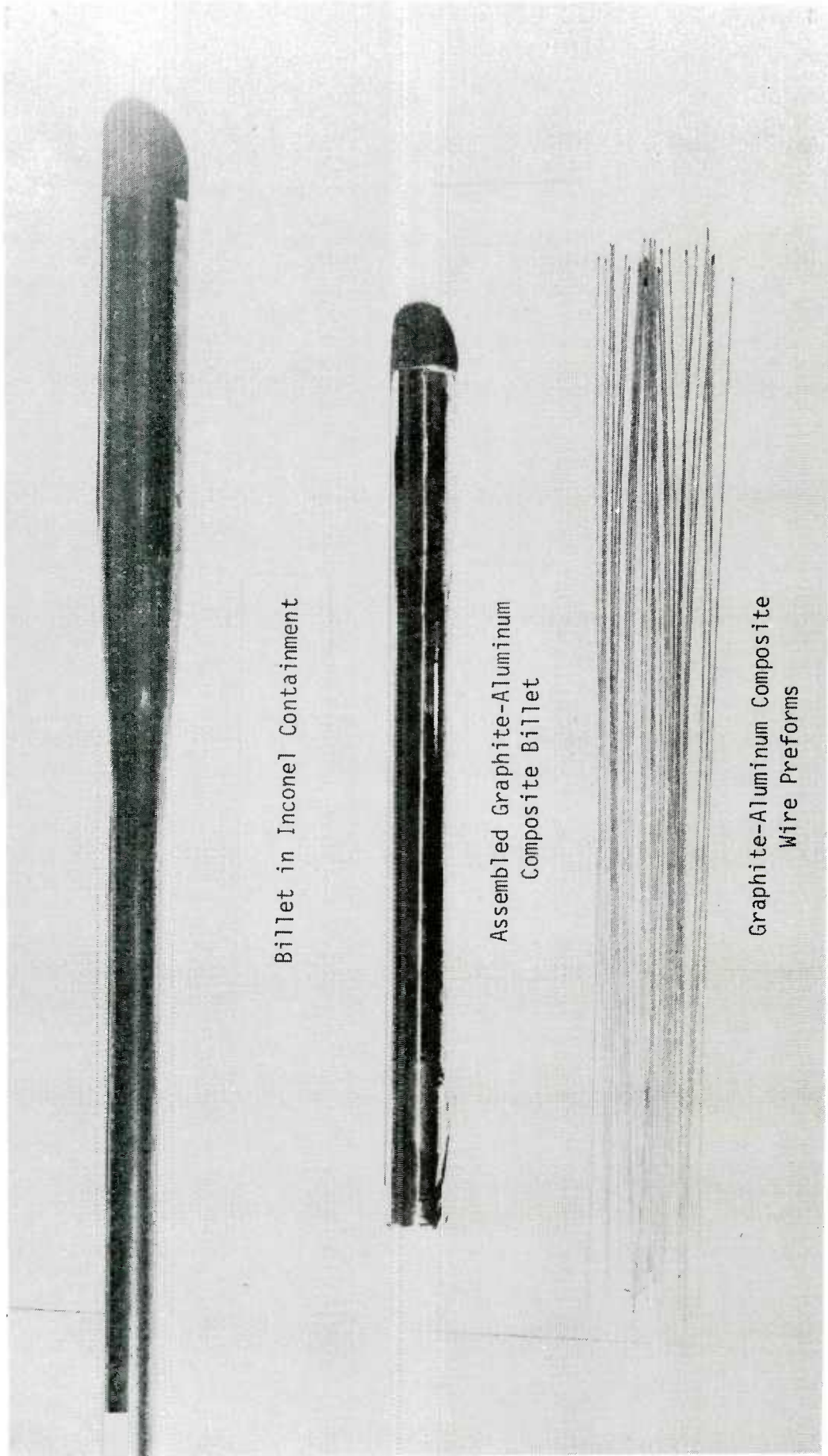

Billet in Inconel Containment

Assembled Graphite-Aluminum  
Composite Billet

Graphite-Aluminum Composite  
Wire Preforms

Figure 6

24" long) to allow the assembled billet to extend through the die and also to allow attachment to vacuum pump and the pulling ram. The inside surface of the Inconel containment is cleaned with acetone prior to assembly and coated with boron nitride which acts as a release agent between the containment and the consolidated bar. A 30 minute bake-out at 500°F, of the boron nitride coated containment in inert atmosphere, is required to eliminate volatiles and to cure the coating. Upon cooling the container, the wire bundle is inserted, and an end cap is welded in place. Once sealed, the billet assembly is leak checked and the outside surface of the container is coated with a graphite based extrusion lubricant.

#### 4.3 Pultrusion Process Parameters

All pultrusion trials were performed in the solid state at  $940^{\circ}\text{F} \pm 10^{\circ}$  at a consolidation rate of 2.5 in./sec. The processing temperature was based on the maximum hot working limit of 6061 Al (i.e., 950°F). Consolidation occurred under vacuum at .1 Torr or less.

#### 5.0 RESULTS OF HOT WORKING GRAPHITE-ALUMINUM COMPOSITES BY PULTRUSION

Preliminary pultrusion trials to establish basic process conditions were conducted using available T300 G/A201\* Al wire preforms. Results of these trials are listed in Table 2. Pultrusion property evaluation trials on T300 G/356 Al and T300 G/6061 Al round bars using single strand 40 v/o graphite-aluminum preforms resulted in the mechanical property data listed in Table 3. Mechanical data for as pultruded and heat treated T300 G/6061 Al bars fabricated from three strand 35 v/o graphite-aluminum preforms is also listed in Table 3 indicated as trial no. 150. The heat treated material condition is representative of properties obtained for final fabrication of bars.

---

\*Al 4.6 Cu .3 Mn .3 Mg .2 Ti .5 Ag Casting Alloy

Table 2

## PRELIMINARY PULTRUSION TRIALS FOR GRAPHITE-ALUMINUM ROUNDS (940°F)

Trial No.	Material	Containment Wall Thickness (in.)	Percent Reduction	Remarks
136	T300/A201 Al	0.035	40	containment failure at leader
137	T300/A201 Al	0.035	40	containment failure at leader
141	T300/A201 Al	0.113	40	failure of containment by kinking (long section)
142	T300/A201 Al	0.113	40	failure of containment by kinking (short section)
139	T300/A201 Al	0.113	30	exceeded workability of composite
140	T300/A201 Al	0.113	30	exceeded workability of composite
138	T300/A201 Al	0.035	25	containment failure
143	T300/A201 Al	0.035	20	containment failure
135	T300/A201 Al	0.035	10	consolidation achieved

Table 3

## MECHANICAL PROPERTIES OF PULTRUDED GRAPHITE-ALUMINUM BARS (SOLID STATE PROCESSED AT 940°F)

Trial No.	Material	Fiber Volume Percent (v/o)	Percent Reduction (% RA)	Ultimate Tensile Strength (ksi)	Elastic Modulus		Strain (%)	Flexural Transverse Strength (psi)
					$E_1 \times 10^6$ (psi)	$E_2 \times 10^6$ (psi)		
145	T300 G (1 Str.)/356 Al	40	15	104	16.8	15.0	0.74	
149	T300 G (1 Str.)/6061 Al	40	15	106 118	-- 17.9	-- 15.2	-- 0.77	4480 Avg. 4980 4730
144	T300 G (1 Str.)/356 Al	40	10	82 (compression) 86 (compression)	16.4 15.2	-- --	0.56 0.65	
148	T300 G (1 Str.)/6061 Al	40	10	130 126	19.8 16.2	14.7 14.6	0.86 0.86	4115 4400 Avg. 4190 4134 3830
146	T300 G (1 Str.)/356 Al	40	5	106 115	15.5 14.3	14.4 --	0.74 0.80	
147	T300 G (1 Str.)/6061 Al	40	5	134 130	20.3 15.5	14.6 14.3	0.89 0.90	6200 3900 Avg. 5630 6083 8600
150	T300 G (3 Str.)/6061 Al (AS PULTRUDED)	35	5	111	18.2	--	0.84	3160 5400 Avg. 5460 4673
150	T300 G (3 Str.)/6061 Al (T6 HEAT TREATED)	35	5	111	18.4	--	0.82	8560 6720 Avg. 6620 7300

## 5.1 Preliminary Pultrusion Trials

Several preliminary pultrusion process trials (trials 135 through 143, Table 2) using available T300 G/A201 Al composite wire preforms were conducted to determine workable containment and die size combinations to subsequently pultrude the composite systems under investigation (i.e., T300 G/356 Al and T300 G/6061 Al) with minimum material loss due to containment failures.

The first trials were set up for high reductions to assure sufficient hot working of composites so as to result in deliberate fiber breakage during processing. Pultrusion of a 40% reduction was unsuccessful using 0.035" wall Inconel containment due to failure of the container leader when load was applied (trials 136 and 137). Thicker walled (0.113") Inconel containment was substituted (trials 141 and 142) with no success due to non-uniform deformation of the containment during pultrusion, resulting in kinking of the assembly at the die orifice and subsequent failure of the container (Figure 7). Lower reductions at 30% (trials 139 and 140), using 0.113" wall Inconel containment were pulled through the die orifice without containment failure. However, upon removal of the graphite-aluminum bar, it was evident that overall segmenting fractures and separations had occurred through the bar section (Figure 8), indicating that the composite hot workability had been exceeded. Consequently, still lower reductions of 10, 20, and 25% (trials 135, 143, and 138, respectively) were set up using 0.035" wall containment. Only the 10% reduction yielded a bar. Both 20 and 25% reductions failed in a similar manner as earlier thin walled containment trials.

It was concluded from these trials that a hot working range between 0% and 15% should be utilized to result in the successful pultrusion of graphite-aluminum bars for property evaluation.

BILLET ASSEMBLY THAT FAILED DURING PULTRUSION DUE TO NON-UNIFORM DEFORMATION  
CAUSED BY EXCESSIVE REDUCTION (40%)

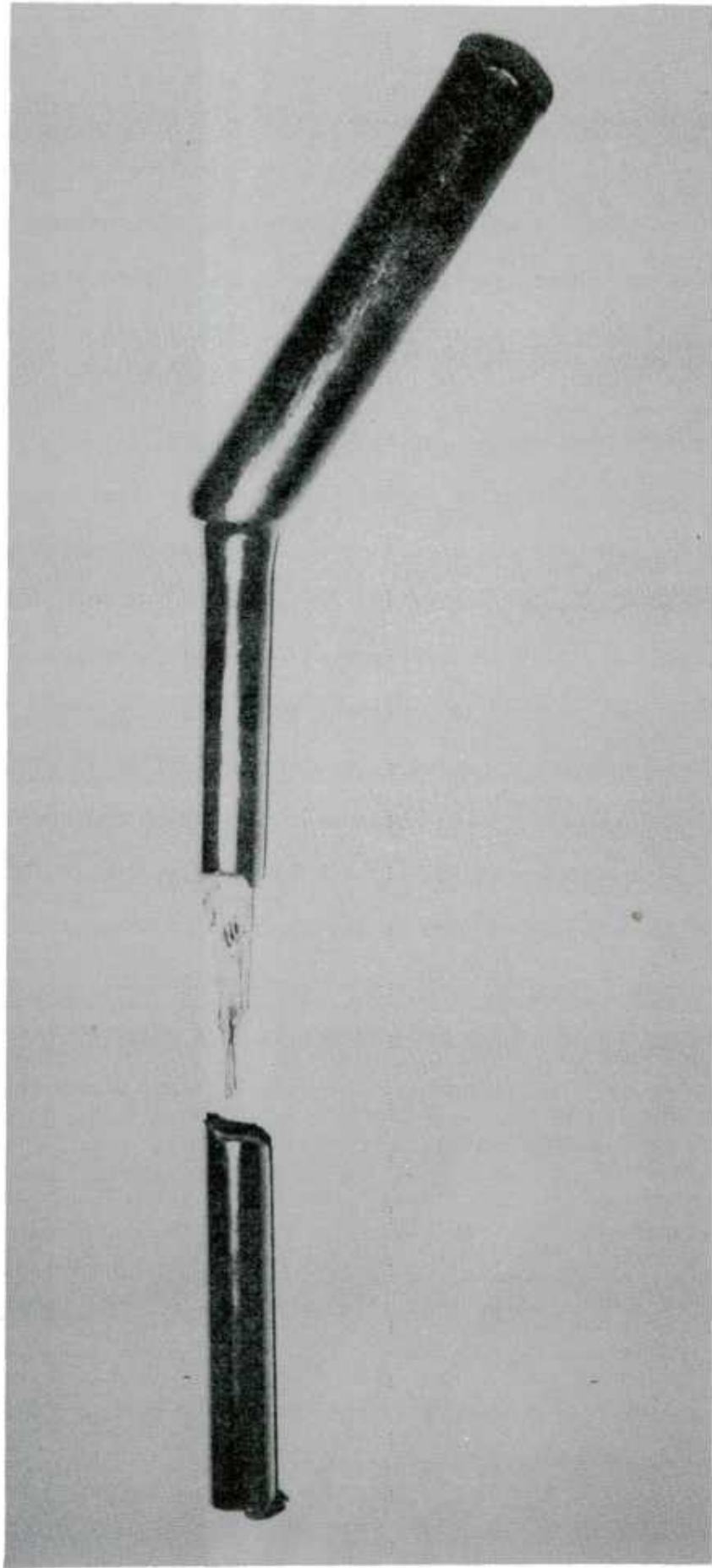

Figure 7

SECTION OF PULTRUDED GRAPHITE-ALUMINUM BAR STOCK PROCESSED IN THE SOLID STATE AT A  
BILLET REDUCTION OF 30% WHERE COMPOSITE HAS FRACTURED INTO SEGMENTS  
DUE TO EXCEEDING HOT WORKABILITY

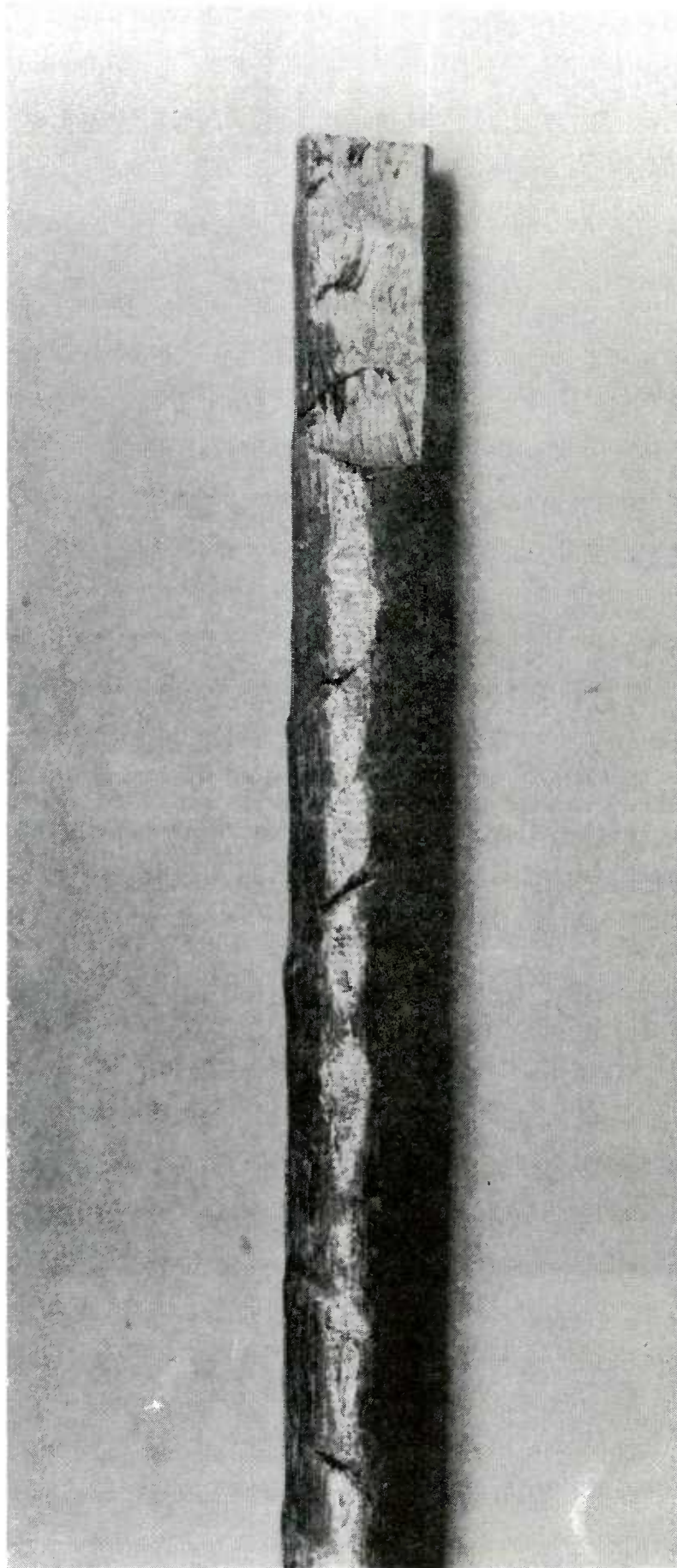

Figure 8

## 5.2 Pultrusion and Mechanical Testing of T300 G/6061 Al and

### T300 G/356 Al Round Bars

The T300 G/6061 Al and T300 G/356 Al pultrusion trials were set up based on the trial and error results of the preliminary processing trials. Using 3/4" OD x 0.035" wall Inconel containment and a 0.525" diameter die, three T300 G/6061 Al composite round bars having nominal dimensions of 0.45" diameter by 12" long were pultruded at 5, 10, and 15% reductions (trials 147, 148, and 149, respectively). Also, three T300 G/356 Al bars were consolidated at 5, 10, and 15% area reductions (trials 146, 144, and 145, respectively) using the same containment/die combination as for the T300 G/6061 Al bars, (for the 15% reduction, 1" OD x 0.113" wall Inconel containment and a 0.756" diameter die was used).

Two tensile specimens were machined from each 12" long x .5" diameter bar in accordance with Figure 9. Figure 10 shows a machined tensile specimen, while Figure 11 shows a typical tensile failure. Figures 12 and 13 are the stress-strain curves obtained for single strand (40 v/o) T300 G/6061 Al at 5, 10, and 15% reductions and T300 G/356 Al at 5 and 15% reductions, respectively. The T300 G/6061 Al series of curves (Figure 12) shows a high UTS of 134,000 psi at 5% RA and a low of 118,000 psi at 15% RA. It is evident from this data that the lower the percent reduction, the higher the ultimate tensile strength and strain-to-failure with little change in the primary (18-20 msi) or secondary moduli (approximately 15 msi). The increased strength at lower percent reduction is also evident in the T300 G/356 Al series of curves (i.e., a high UTS of 115,000 psi at 5% RA and a low UTS of 104,000 psi at 15%, Figure 13). The T300 G/6061 Al composite consistently shows higher ultimate tensile values than the T300 G/356 Al at all reductions. The highest

TENSILE SPECIMEN CONFIGURATION

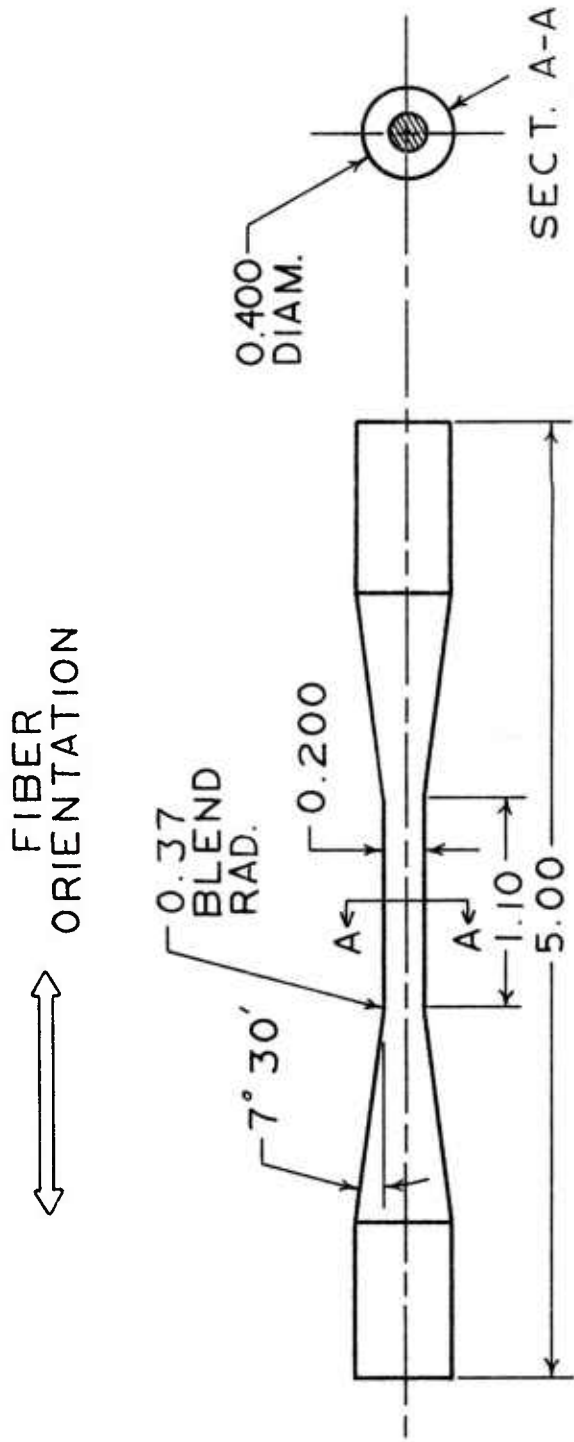

Figure 9

GRAPHITE-ALUMINUM TENSILE SPECIMEN

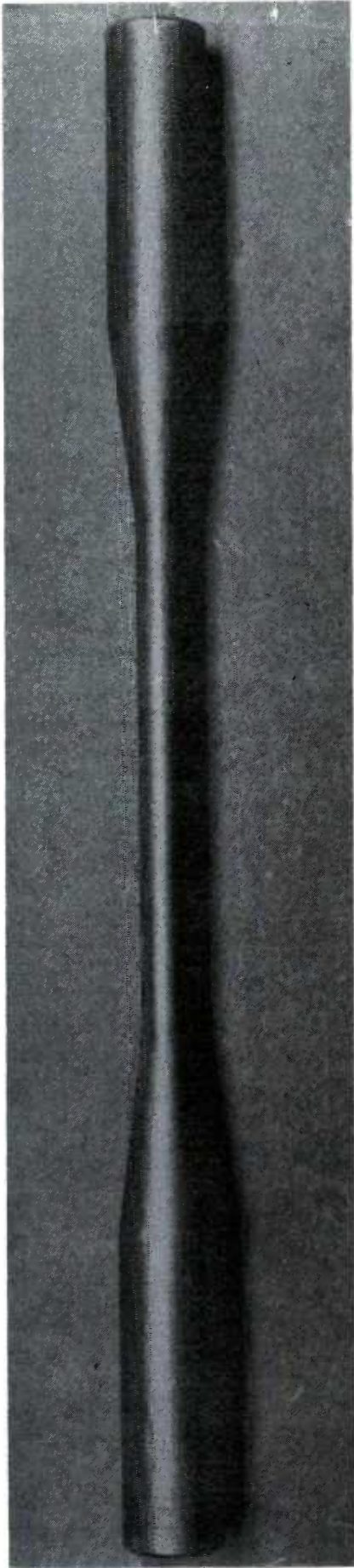

Figure 10

GRAPHITE-ALUMINUM TENSILE SPECIMEN AFTER TESTING SHOWING MANNER OF FAILURE

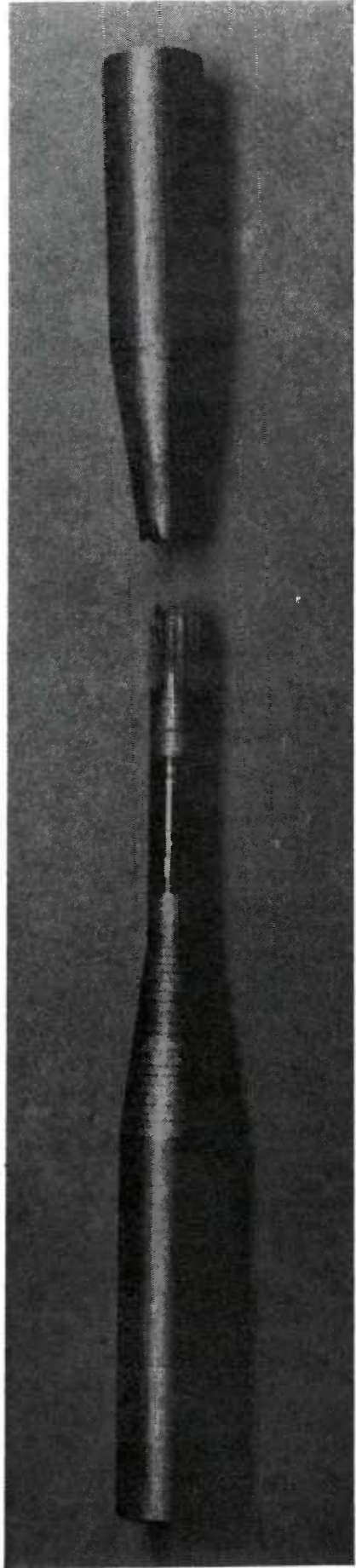

Figure 11

Figure 12

TYPICAL STRESS-STRAIN BEHAVIOR OF T300 G/6061 A1  
PULTRUDED COMPOSITE BAR STOCK

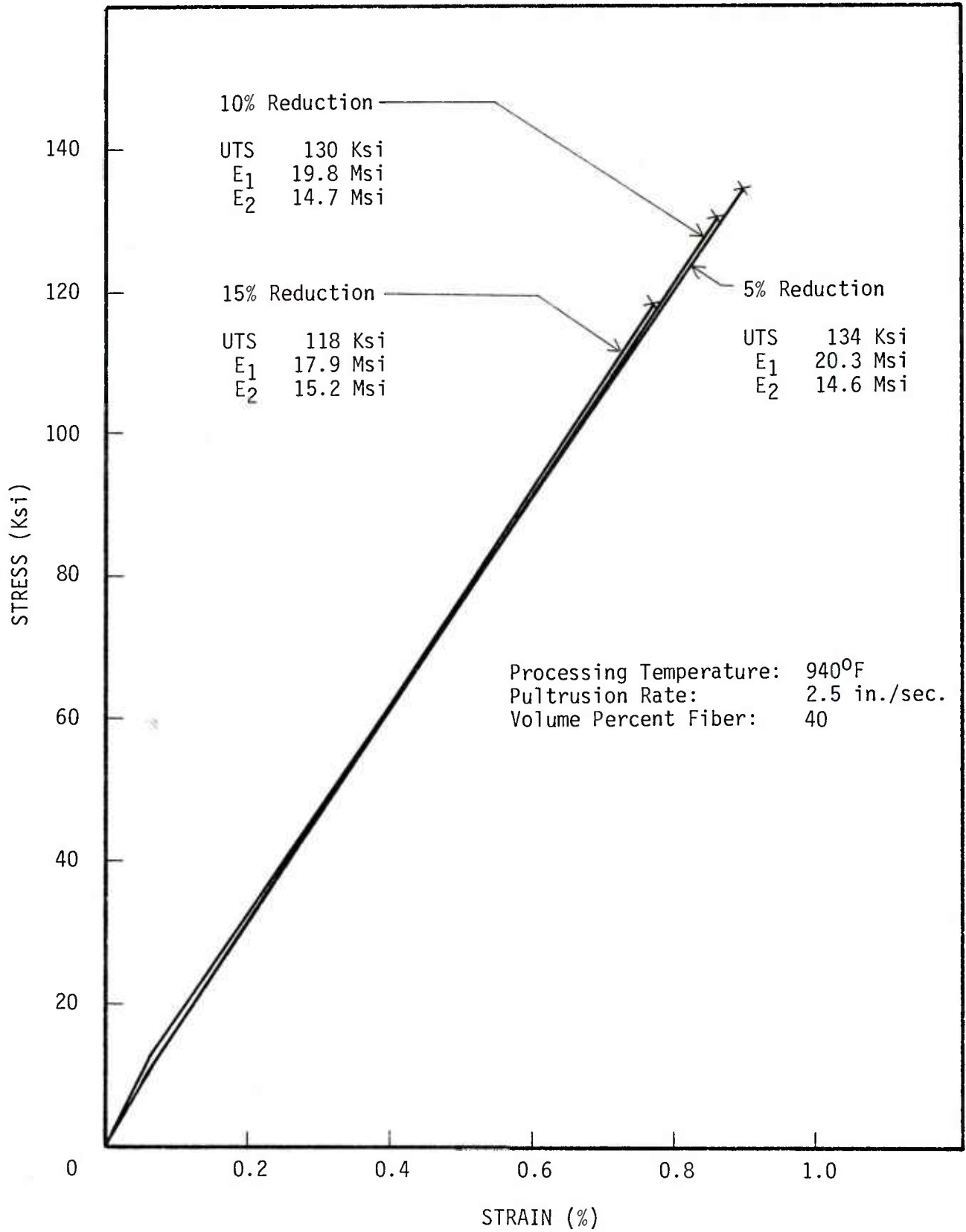
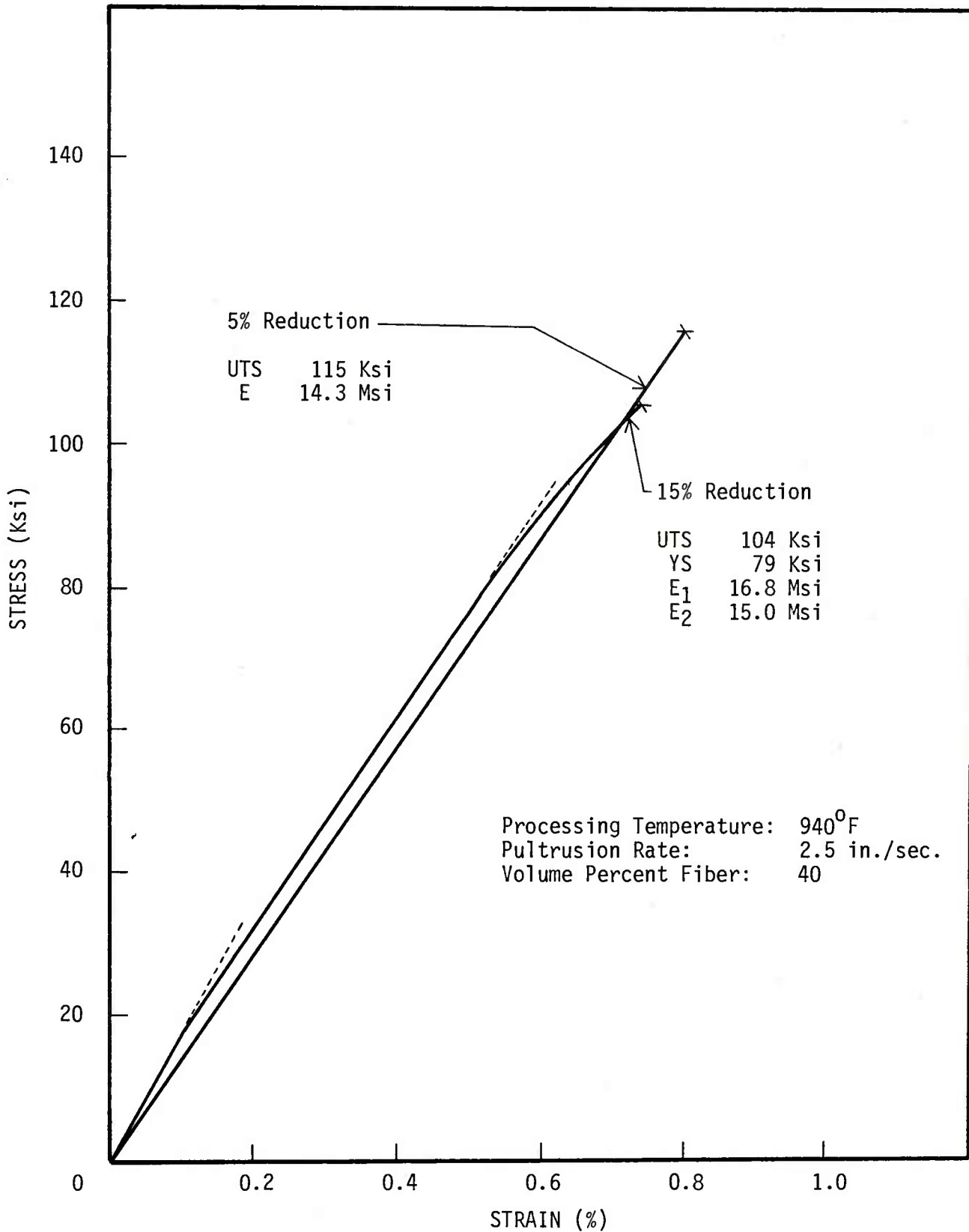

Figure 13

TYPICAL STRESS-STRAIN BEHAVIOR OF T300 G/356 A1 PULTRUDED  
COMPOSITE BAR STOCK



tensile values obtained were 134,000 psi for T300 G/6061 Al as opposed to 115,000 psi for T300 G/356 Al, both at 5% RA.

Examination of transverse strength data determined in flexure on 40 v/o T300 G/6061 Al rectangular coupons machined from rounds (Figure 14), generally indicated higher transverse strengths for 5% RA bars than for the 10% and 15% bar reductions. Average values of 6083 psi at 5% RA vs. 4134 psi and 4730 psi at 10% and 15% RA respectively are shown in Table 3. This trend is consistent with the higher tensile strengths observed previously at 5% RA. Based on these results, the T300 G/6061 Al composite system was chosen for further fabrication investigations.

In an attempt to improve the transverse strength of the T300 G/6061 Al composite bars, additional aluminum was effectively added to the composite structure by fabricating round bars from a lower volume percent graphite-aluminum preform. This preform consisted of three fiber tows rather than a single tow resulting in a 35 v/o wire with an average UTS of 150,000 psi. The aluminum network throughout the composite structure and heat treating the composite matrix to a standard 6061-T6 condition, in principal may strengthen the fiber composite in the transverse direction, due to the isotropic strength contribution of the aluminum matrix. Tensile and flexural transverse strengths were determined for both as pultruded and T6 heat treated conditions for bars fabricated in the above described manner. As indicated in Table 3 (trial no. 150), an ultimate tensile strength of 111,000 psi and a modulus of (18 msi) were obtained for both bar conditions at the lower volume percent fiber, indicating that the strength and stiffness of the composite in the tensile direction of the bars is primarily a function of the fiber volume percent. Comparison of average transverse strengths in

TRANSVERSE FLEXTURE SPECIMEN CONFIGURATION

⊗ FIBER ORIENTATION

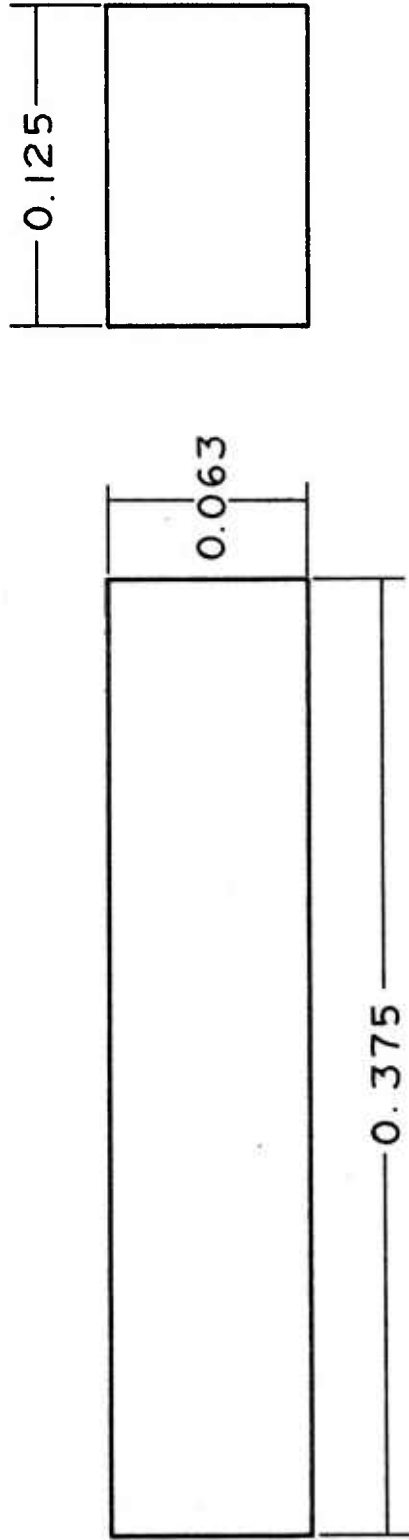

Figure 14

the as pultruded vs. T6 heat treated conditions, however, indicated an average transverse strength increase from 4673 psi to 7300 psi, respectively. The heat treated strengths were consistently higher and tended to accumulate towards the high end of the transverse strength range for graphite-aluminum than values obtained for as pultruded material of the same batch (i.e., trial no. 150, Table 3).

Therefore, six round bars (each approximately .5" diameter x 12") were fabricated from the three strand 35 v/o T300 G/6061 Al preforms and given a 6061-T6 standard heat treatment prior to delivery of the bars to AMMRC for evaluation.

### 5.3 Pultrusion of T300 G/6061 Al Rectangular Bars

Six rectangular section bars of nominal dimensions .75" x .18" x 12" were fabricated by pultrusion from three strand 35 v/o T300 G/6061 Al wire preforms. Although the bars were well consolidated, all pultruded bars of rectangular section exhibited a twist along the longitudinal axis (Figure 15). Attempts to eliminate the twist during pultrusion included careful alignment of pultrusion can, die, and clamping device and stress relieving heat treatments of the Inconel container. Although the distortion effect was minimized through these efforts, the axial twist could not be eliminated. One attempt to straighten a bar by hot forming at 950<sup>0</sup>F partially corrected the twist condition; however, micro cracks were evident upon examination of both ends of the bar. Therefore, no further attempts were made to straighten remaining bars. It was concluded that the axial twisting of non-round graphite-aluminum sections during pultrusion is caused by the formation of anisotropic working stresses generated in the billet assembly during consolidation of the composite section. Further development work on the

AS PULTRUDED RECTANGULAR SECTION BAR SHOWING TWIST ALONG BAR AXIS

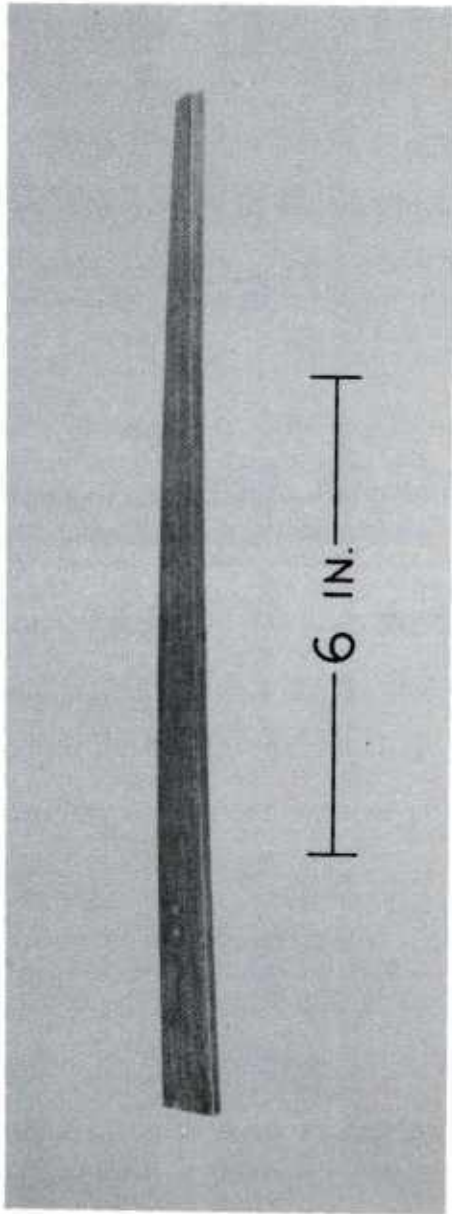

(a) Overall View

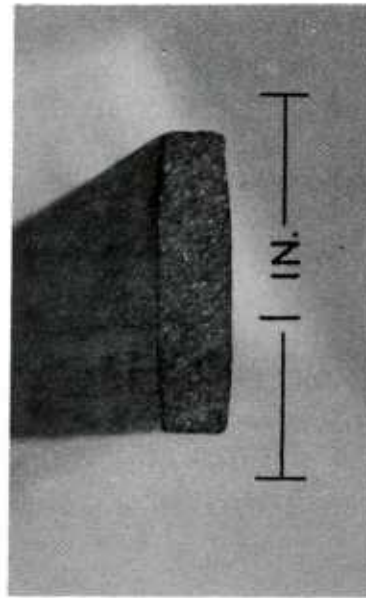

(b) Sectional View

Figure 15

pultrusion process is required to eliminate these distortions during forming of non-round composite sections.

Several bars, exhibiting the least twist, were subjected to the standard 6061 Al T6 heat treatment in an effort to obtain tensile and transverse specimens for testing. The heat treatment, however, resulted in the relief of residual stress resulting from twisting during pultrusion and splitting (during solution and quench cycle) of the bars (Figure 16). Therefore, due to the process difficulties encountered, suitable specimens from the rectangular sections were not obtained for mechanical testing.

## 6.0 DISCUSSION

Both the T300 G/6061 Al and T300 G/356 Al composites were successfully consolidated in the solid state by pultrusion with resultant high strengths ( $>100,000$  psi) and moduli (18 msi) being achieved for round bar stock, hot worked in the range of 5 to 15% RA. Examination of metallographic sections from consolidated graphite-aluminum round bars at various percent reductions indicates that sound composite structures are achieved by pultrusion processing in the solid state (Figure 17). Of significance is the fact that, although a substantial number of continuous graphite fiber reinforcements have deliberately been fractured due to pultrusion hot working thereby creating the discontinuous fiber structure, there are no process initiated defects (such as voids) evident at the broken fiber ends (Figure 18). Dark areas in Figure 18a at ends of fibers are where fiber pullout has occurred during polishing. In fact, at high magnifications (Figure 18b), it is evident that even around the smallest fiber/matrix discontinuities, matrix flow has occurred and filled (i.e., healed) the broken fiber ends. This observation is very significant since it shows that the graphite-aluminum

SPLIT RECTANGULAR SECTION AFTER SOLUTION AND QUENCH CYCLE

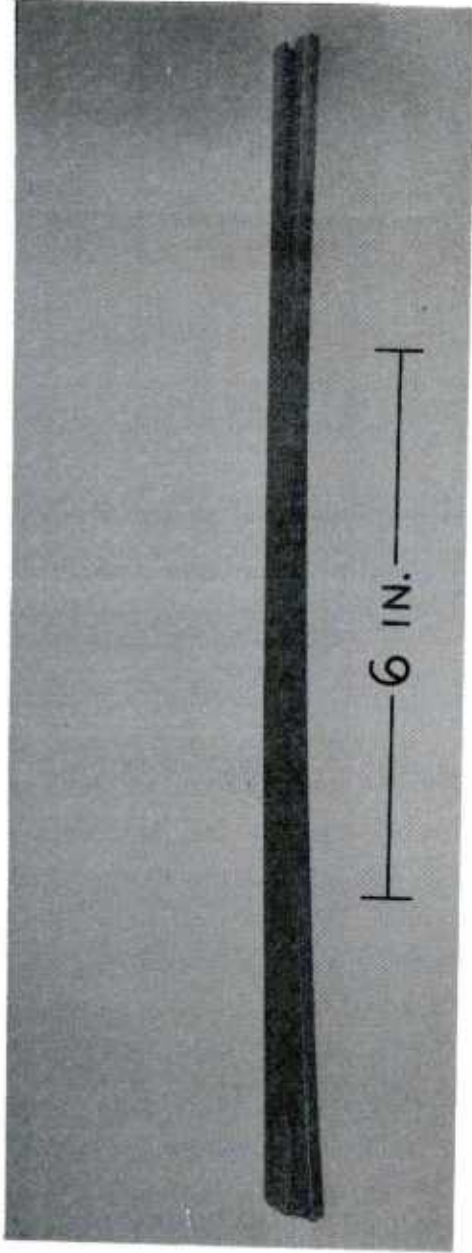

(a) Overall View

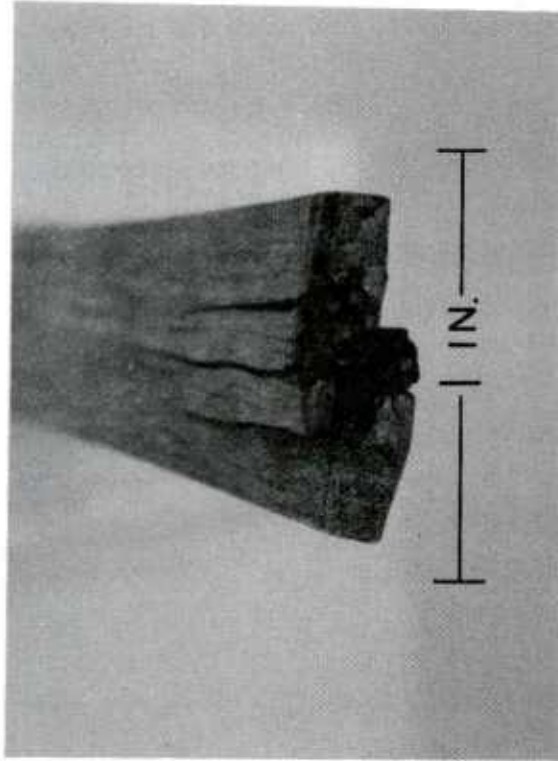

(b) Sectional View

Figure 16

Figure 17

TYPICAL TRANSVERSE MICROSTRUCTURES OF PULTRUDED GRAPHITE-ALUMINUM ROUND BAR STOCK  
PROCESSED IN THE SOLID STATE

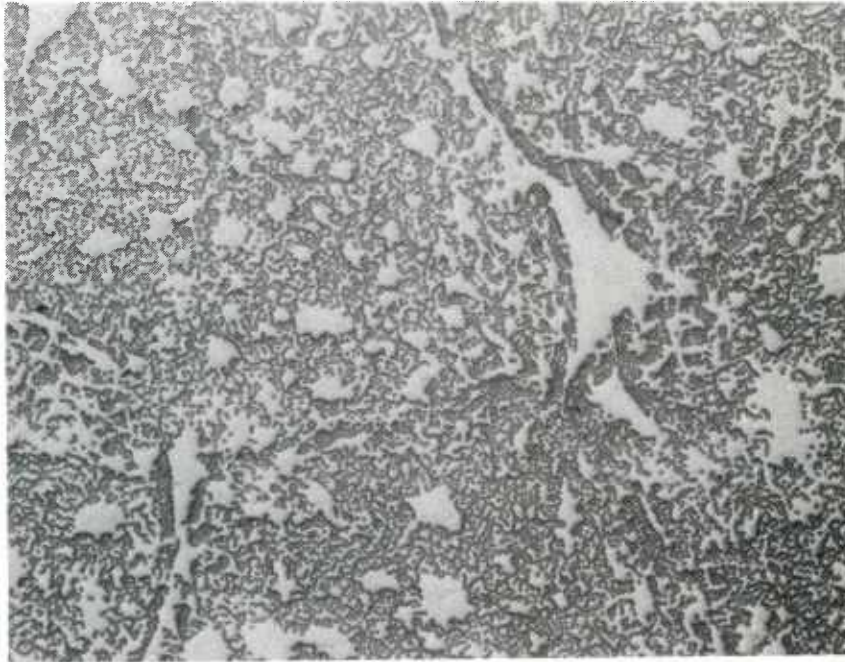

T300 G/6061 Al  
(10% reduction)

Mag. 78X  
As Polished

(a)

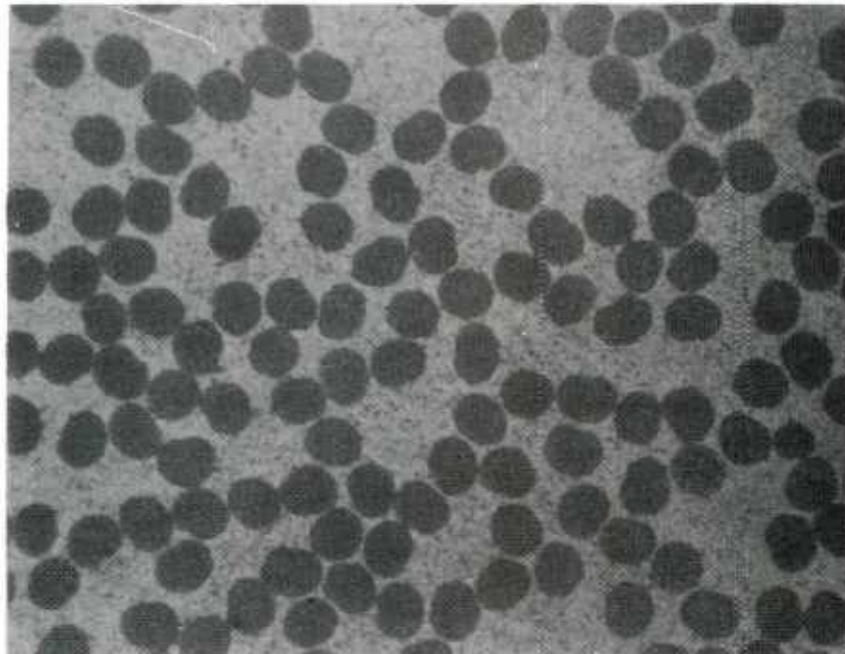

T300 G/6061 Al  
(10% reduction)

Mag. 1000X  
As Polished

(b)

Figure 18

LONGITUDINAL MICROSTRUCTURE OF PULTRUDED GRAPHITE-ALUMINUM ROUND BAR STOCK

PROCESSED IN THE SOLID STATE

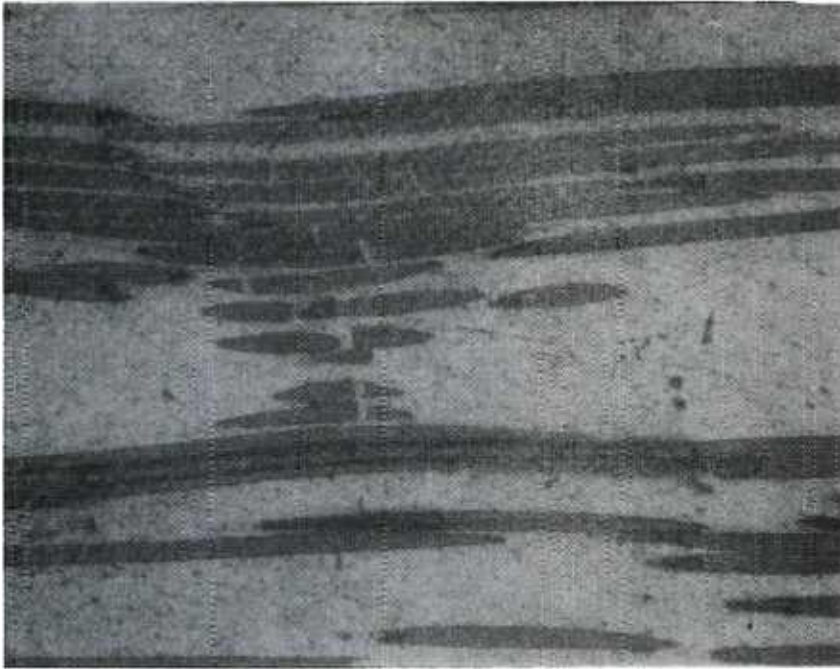

T300 G/6061 Al  
(10% reduction)

Mag. 400X  
As Polished

(a)

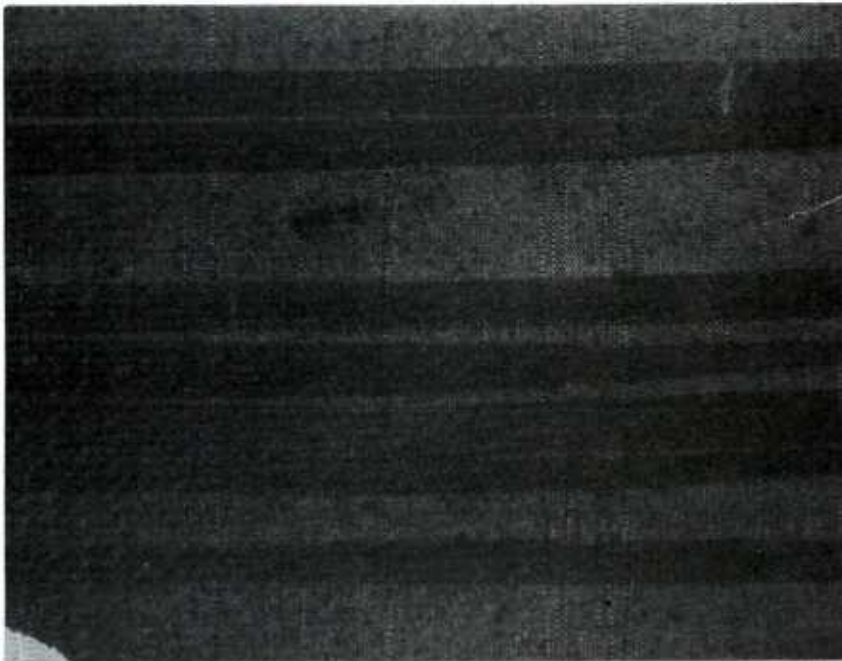

T300 G/6061 Al  
(10% reduction)

Mag. 1000X  
As Polished

(b)

composite can withstand a significant amount of hot working without loss of composite properties. This has important implications for the future fabrication and sizing of complex structural sections where a high degree of thermal-mechanical treatment of the composite becomes necessary to obtain specific engineering structures for critical applications.

The slight increase in flexural transverse strength noted on heat treatment indicates that improvements in transverse strength may be realized for lower volume percent fiber composites by extending the continuous aluminum matrix network throughout the composite structure. This enables the aluminum matrix (in the heat treated condition) to contribute its isotropic strength in the transverse direction of the composite. Since increasing the volume percent aluminum to increase transverse strengths lowers the longitudinal properties, a predetermined balance between longitudinal tensile and transverse strength will be required for particular applications.

Although rectangular section graphite-aluminum bars were successfully consolidated by pultrusion, further process development for non-round sections is required to eliminate bar distortion (axial twist) due to anisotropic stress effects. Also, splitting of bars during heat treatment needs to be resolved. The application of die constraints and straightening guides would probably eliminate twisting of non-round cross-sections during pultrusion. However, a more permanent solution is required through process modification. This would entail redesign of the process to eliminate the present requirements of pultrusion containment (i.e., Inconel can) for the graphite-aluminum during section consolidation. The design and fabrication of specialized pultrusion hardware/tooling is required to achieve this end. Splitting of bars during heat treatment can be eliminated through modifications of the

heat treating cycle (i.e., a less severe quench from solutionizing temperature). This phenomena may also be partly related to residual stresses in the composite, induced by axial distortion, during consolidation.

It is clear from this investigation that thermal-mechanical working of graphite fiber reinforced aluminum composites has been successfully demonstrated and, that through further process development, complex graphite-aluminum composite shapes with desirable properties can be successfully fabricated by the pultrusion process.

## 7.0 CONCLUSIONS

1. Thermal-mechanical working of graphite-aluminum via pultrusion fabrication with accompanying high strengths and moduli (in excess of 100,000 psi UTS and 16-20 msi moduli) for PAN based T300 G/6061 Al and T300 G/356 Al composite round bar stock has been demonstrated at cross-sectional reductions in area of 5 to 15%.

2. Higher strengths are obtained for T300 G/6061 Al (134,000 psi, 5% RA) round bar stock than for T300 G/356 Al (115,000 psi, 5% RA) at all reductions. Lower reductions yield higher tensile and transverse strengths.

3. Transverse strength in graphite-aluminum may be improved by lowering the volume percent fiber in the composite and hardening the matrix. Modifications in heat treatment practice are required to prevent splitting.

4. Area reductions during pultrusion processing (between 5 and 15%) result in substantial fiber breakage with no process induced defects. Matrix flow occurs around broken fiber ends, filling in and effectively healing the composite, thus resulting in a high strength and stiffness, discontinuous fiber structure.

5. Distortion of rectangular sections occurs due to anisotropic stress effects generated during billet consolidation. Further process development is required for non-round sections.

#### 8.0 RECOMMENDATIONS FOR FUTURE WORK

1. Further development is required on the pultrusion process to eliminate distortion of non-round sections during consolidation. Immediate efforts should concentrate on rectangular sections. Short term solution requires the design and application of die constraints and straightening guides to present process. Long term solution requires process modifications through redesign of equipment to eliminate containment for graphite-aluminum wire preforms, thus avoiding anisotropic stresses generated during billet consolidation.

2. Investigate apparent improvements on composite transverse strength by heat treatments. Modifications in standard heat treating practice may be required to avoid damage to material.

3. Develop pultrusion fabrication of thin wall sections ( $< 0.1$ " thick) on rectangular flats leading to future processing of angle structures (e.g., "C" sections) via pultrusion.

## DISTRIBUTION LIST

No. of Copies	To
1	Office of the Director, Defense Research and Engineering, The Pentagon, Washington, D. C. 20301
12	Commander, Defense Documentation Center, Cameron Station, Building 5, 5010 Duke Street, Alexandria, Virginia 22314
1	Metals and Ceramics Information Center, Battelle Columbus Laboratories, 505 King Avenue, Columbus, Ohio 43201
	Chief of Research and Development, Department of the Army, Washington, D. C. 20310
2	ATTN: Physical and Engineering Sciences Division
	Commander, Army Research Office, P. O. Box 12211, Research Triangle Park, North Carolina 27709
1	ATTN: Information Processing Office
	Commander, U. S. Army Materiel Development and Readiness Command, 5001 Eisenhower Avenue, Alexandria, Virginia 22333
1	ATTN: DRCLDC, Mr. R. Zentner
	Commander, U. S. Army Electronics Command, Fort Monmouth, New Jersey 07703
1	ATTN: DRSEL-GG-DD
1	DRSEL-GG-DM
	Commander, U. S. Army Missile Command, Redstone Arsenal, Alabama 35809
1	ATTN: Technical Library
1	DRSMI-RSM, Mr. E. J. Wheelahan
	Commander, U. S. Army Armament Command, Rock Island, Illinois 61201
2	ATTN: Technical Library
1	DRSAR-SC, Dr. C. M. Hudson
1	DRSAR-PPW-PB, Mr. Francis X. Walter
	Commander, Frankford Arsenal, Philadelphia, Pennsylvania 19137
1	ATTN: SARFA-L300, Mr. J. Corrie
	Commander, U. S. Army Foreign Science and Technology Center, 220 7th Street, N. E., Charlottesville, Virginia 22901
1	ATTN: DRXST-SD2
	Naval Research Laboratory, Washington, D. C. 20375
1	ATTN: Dr. J. M. Krafft - Code 8430
	Chief of Naval Research, Arlington, Virginia 22217
1	ATTN: Code 471

No. of Copies	To
	Air Force Materials Laboratory, Wright-Patterson Air Force Base, Ohio 45433
2	ATTN: AFML/MXE/E. Morrissey
1	AFML/LC
1	AFML/LLP/D. M. Forney, Jr.
1	AFML/MBC/Mr. Stanley Schulman
	National Aeronautics and Space Administration, Washington, D. C. 20546
1	ATTN: Mr. B. G. Achhammer
1	Mr. G. C. Deutsch - Code RR-1
	National Aeronautics and Space Administration, Marshall Space Flight Center, Huntsville, Alabama 35812
1	ATTN: R-P&VE-M, R. J. Schwinghamer
1	S&E-ME-MM, Mr. W. A. Wilson, Building 4720
1	Mechanical Properties Data Center, Belfour Stulen, Inc., 13917 W. Bay Shore Drive, Traverse City, Michigan 49684
	Director, Army Materials and Mechanics Research Center, Watertown, Massachusetts 02172
2	ATTN: DRXMR-PL
1	DRXMR-PR
1	DRXMR-X
1	DRXMR-XP
1	DRXMR-K
1	DRXMR-AP
1	DRXMR-CT
1	Author