

AD-A039 997

HARRY DIAMOND LABS ADELPHI MD
THE PLACER: ASSEMBLY AND OPERATION.(U)
APR 77 D L GOODWIN
HDL-TM-77-7

F/G 20/3

UNCLASSIFIED

NL

| OF |

AD
A039997



END

DATE
FILMED
6-77

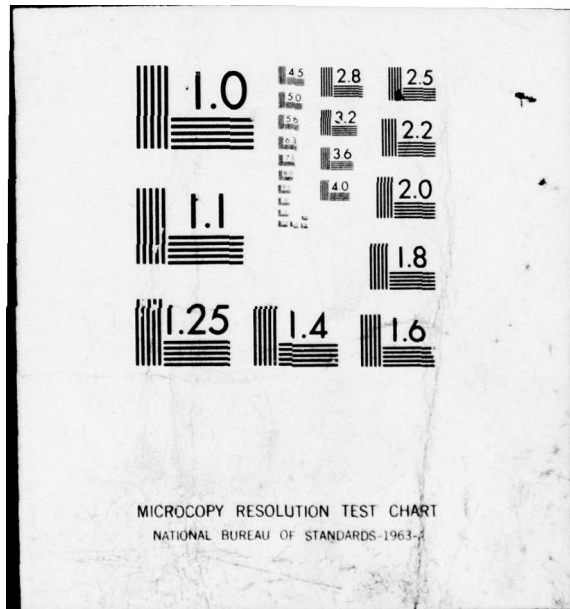

NDL 77-77-3

(Handwritten mark)
D.S.

ADA 039997

THE PLACER: Assembly and Operation by Daniel L. Gorman

The PLACER: Assembly and Operation

April 1977



AD NO. _____
DDC FILE COPY



U.S. Army Material Development
and Readiness Command
HARRY DIAMOND LABORATORIES
Adapted, Maryland 20783

PRINTED FOR PUBLIC RELEASE BY THE ARMY

ADL-1M

The findings in this report are not to be construed as an official Department of the Army position unless so designated by other authorized documents.

Citation of manufacturer's or trade names does not constitute an official endorsement or approval of the use thereof.

Destroy this report when it is no longer needed. Do not return it to the originator.

UNCLASSIFIED

SECURITY CLASSIFICATION OF THIS PAGE (When Data Entered)

REPORT DOCUMENTATION PAGE		READ INSTRUCTIONS BEFORE COMPLETING FORM
1. REPORT NUMBER 14 HDL-TM-77-7	2. GOVT ACCESSION NO.	3. RECIPIENT'S CATALOG NUMBER
4. TITLE (and Subtitle) 6 The PLACER: Assembly and Operation	7. AUTHOR(s) 10 Daniel L. Goodwin	5. TYPE OF REPORT & PERIOD COVERED 9 Technical Memorandum
9. PERFORMING ORGANIZATION NAME AND ADDRESS Harry Diamond Laboratories 2800 Powder Mill Road Adelphi, MD 20783	11 CONTROLLING OFFICE NAME AND ADDRESS Ballistic Missile Defense Sys Command P.O. Box 1500 Huntsville, AL 35807	6. PERFORMING ORG. REPORT NUMBER
14. MONITORING AGENCY NAME & ADDRESS (if different from Controlling Office)	15. SECURITY CLASS. (of this report) UNCLASSIFIED	8. CONTRACT OR GRANT NUMBER(s) PRON: 0R4C056401A1A9 MIPR: 4V9211
16. DISTRIBUTION STATEMENT (of this Report) Approved for public release; distribution unlimited.	15a. DECLASSIFICATION/DOWNGRADING SCHEDULE	10. PROGRAM ELEMENT, PROJECT, TASK AREA & WORK UNIT NUMBERS N/A
17. DISTRIBUTION STATEMENT (of the abstract entered in Block 20, if different from Report)	12. REPORT DATE Apr 10 1977	13. NUMBER OF PAGES 25 (12) 22P
18. SUPPLEMENTARY NOTES DRCMS Code: 691100.21.10772 HDL Project: E184E4	15. SECURITY CLASS. (of this report) UNCLASSIFIED	
19. KEY WORDS (Continue on reverse side if necessary and identify by block number) PLACER Loop antenna Conduit fault location Electromagnetic pulse	Pulser Conduit tester	
20. ABSTRACT (Continue on reverse side if necessary and identify by block number) This report describes the assembly and operation instructions of the PLACER, a test system for discovering and locating electromagnetic-pulse shielding flaws in underground conduits.		

D D C
 REPRODUCED
 MAY 27 1977
 HUNTSVILLE
 C

DD FORM 1 JAN 73 1473

EDITION OF 1 NOV 65 IS OBSOLETE

UNCLASSIFIED

1 SECURITY CLASSIFICATION OF THIS PAGE (When Data Entered)

163 454 mly

CONTENTS

	<u>Page</u>
1. BACKGROUND	5
2. DESCRIPTION OF PLACER	5
2.1 Overview	5
2.2 Pulse Generator System	5
2.2.1 High-Voltage Power Supply	5
2.2.2 Pulser	7
3. ASSEMBLY OF COMPONENTS	8
3.1 Cart	8
3.2 High-Voltage Power-Supply System	9
3.3 Pulser Assembly	9
4. ASSEMBLY OF PLACER	13
5. TURN-ON PROCEDURE	13
6. CHARGING PROCEDURE FOR 5-LB BOTTLE OF SF ₆	13
7. PLACER CALIBRATION CHECK	15
8. PROCEDURE FOR FLAW LOCATION	16
APPENDIX A.--ABOVEGROUND ELECTRIC FIELD PRODUCED BY THE PLACER .	19
DISTRIBUTION	23

FIGURES

1 The PLACER	6
2 High-voltage power supply	6
3 Pulser	7
4 High-voltage power supply	8
5 Front panel of high-voltage power-supply system	10
6 Pulser ground-plate assembly	11
7 Pulser housing, cylinder	12
8 Gap housing assembly	12
9 Setup for charging SF ₆ bottle	14
10 Test setup for loop antenna current calibration	15
11 Loop antenna current	16
12 Flaw location technique for PLACER	17
TABLE I. Checklist for Placer	18

A	ACCESSION NO.	
	DATE	
	REMOVED	
	JUSTIFICATION	
	DISTRIBUTION/AVAILABILITY	
	DATE	

1. BACKGROUND

Equipment and procedures have been developed for locating flaws in buried conduits by excitation of these conduits with a Pulsed Loop Antenna Conduit Electromagnetic Radiator (PLACER). Complete Protection Integrity Maintenance (PIM) procedures for locating flaws with the PLACER may be found in the five-volume series of Harry Diamond Laboratories (HDL) manuals numbered HDL-SR-75-1 through HDL-SR-75-5. This manual discusses the construction, assembly, and operation of the PLACER. Some system safety considerations are discussed in appendix A.

A requirement to validate the electromagnetic integrity of the buried conduits at the Safeguard Antiballistic Missile (ABM) Defense System deployed at the Grand Forks, ND, tactical site instigated the development of the PLACER. These conduits, through which run signal and power cables which serve the missiles, are one element of the electromagnetic pulse (EMP) protection for the ABM system. These conduits were employed at all five missile sites, and the total conduit system included about 40 miles (64 km) of conduit. The magnitude of the conduit system and the fact that flaws must be located and repaired indicated that a small transportable tester should be developed.

2. DESCRIPTION OF PLACER

2.1 Overview

The central feature of the PLACER is the loop antenna. The antenna consists of a single loop of aluminum tubing (1-in. i.d.) (2.54 cm) 9 ft (2.7 m) in diameter. The loop is mounted on the side of a three-wheeled cart with the loop antenna in a horizontal plane approximately 2 ft (0.6 m) above the ground. The loop antenna is excited by a pulse generator system which also is mounted on the cart; thus, the PLACER is mobile (fig. 1, p 6).

2.2 Pulse Generator System

The pulse generator system consists of the high-voltage power supply and the pulser. The pulse generator system develops the high-voltage pulse (0 to 40 kV) that is applied to the loop antenna to produce an electromagnetic field.

2.2.1 High-Voltage Power Supply

The high-voltage power supply operates as follows (fig. 2): With switch S1 in the internal power mode, the 12-Vdc battery supplies power to the inverter, and the inverter supplies 110 Vac to the

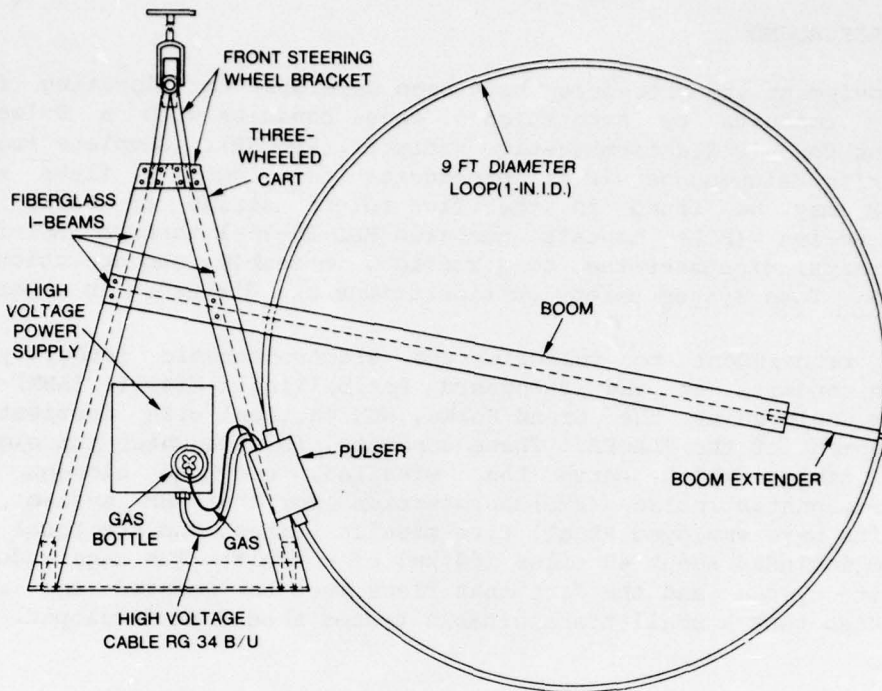

Figure 1. The PLACER (scale 2.57:1).

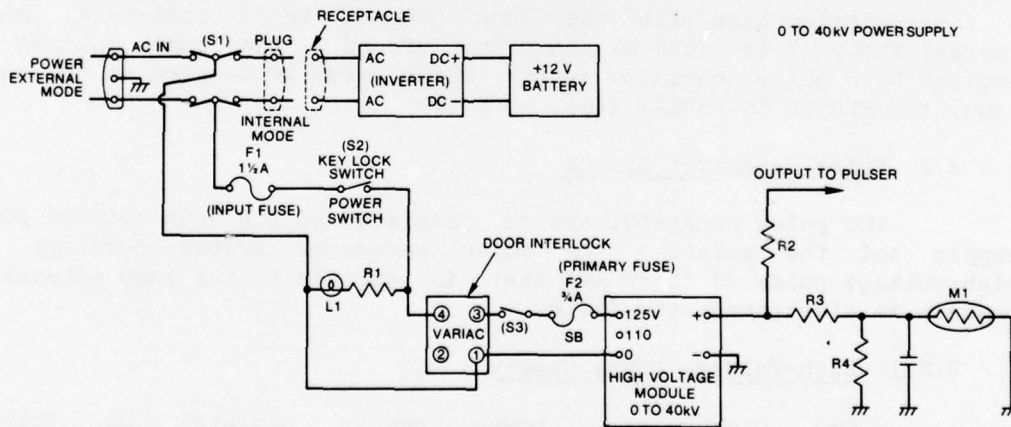

Figure 2. High-voltage power supply.

Variac. The Variac adjusts the ac voltage supplied to the high-voltage module, which produces a variable (0 to 40 kV) high-voltage dc output. If S1 is in the external power mode, the 12-V battery and inverter are bypassed, and power from an external source (ac generator or line) can be supplied directly to the Variac. Switch S2 is an ignition key switch that disconnects power to the Variac. This key switch is provided for safety and security. Neon bulb L1 lights when power is being supplied to the Variac. The door interlock, S3, is a safety feature that inhibits the high-voltage dc output until the door of the high-voltage supply cabinet is latched. The meter, M1, displays the high-voltage dc obtained from the high-voltage module. The high-voltage dc output of the high-voltage module is fed to the pulser.

2.2.2 Pulser

The pulser operates as follows: The high-voltage dc from the high-voltage power supply charges capacitor C1 through resistor R1 (fig. 3). When C1 is charged to the spark-gap breakover voltage, the gap ionizes and sends current through the 50- Ω impedance and the loop antenna. The 50- Ω equivalent resistance, the loop antenna, and C1 form a resistance-inductance-capacitance (RLC) network, which is designed for a critically damped response. The current through these components produces a localized electromagnetic field, which can couple current onto buried conduits. When the voltage on C1 drops to the cutoff value at which the gap no longer conducts, C1 recharges to start the cycle again. The spark-gap conduction is controlled by the gap spacing (which can be adjusted) and by the pressure of sulfur hexafluoride (SF₆) gas in the pulser housing. The spark gap is vented so that the SF₆ gas can flood the gap housing. The miniature SF₆ gas bottle is mounted in a shielded cavity in the high-voltage power-supply housing (fig. 4).

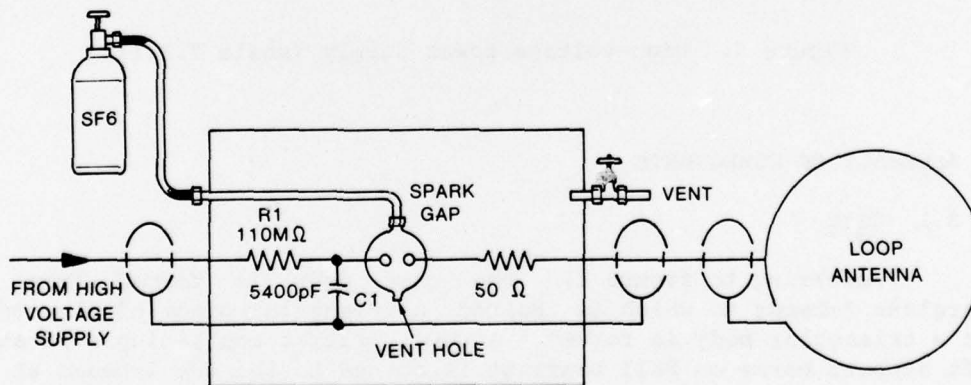

Figure 3. Pulser.

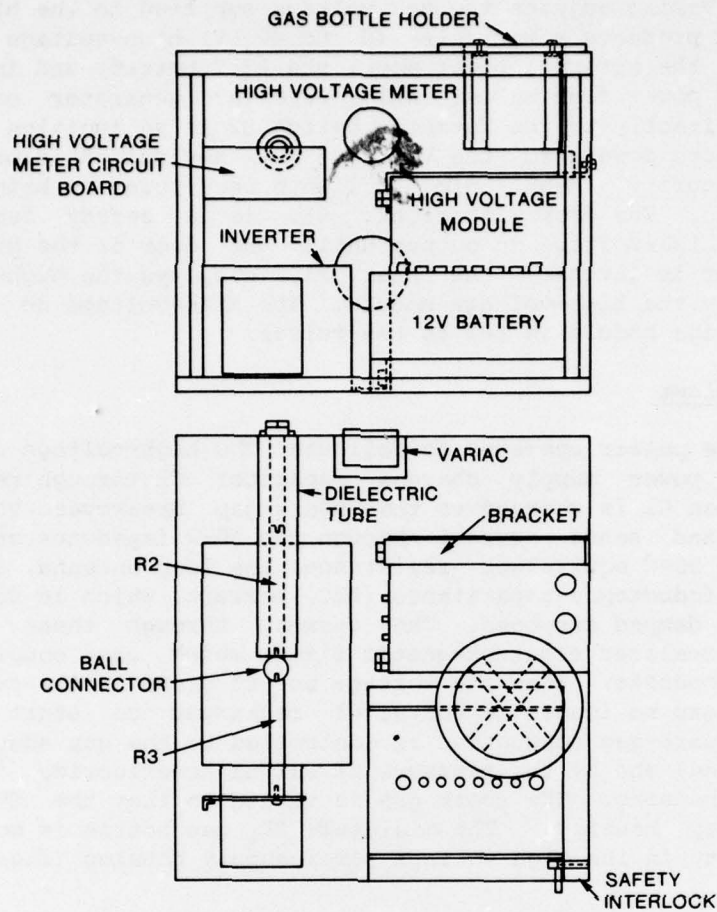

Figure 4. High-voltage power supply (scale 7.1:1)

3. ASSEMBLY OF COMPONENTS

3.1 Cart

Referring to figure 1, the cart body is formed from two fiberglass I-beams to which is bolted a triangular piece of plywood so that a triangular body is formed. A wheel bracket containing a rotating shaft support borne on ball bearings is bolted to the two I-beams at the front of the cart where they form the apex of a triangle. The shaft of the front wheel assembly fits into the shaft support, and attached to the front wheel is a steering bracket to which the handle is bolted.

The other two wheels are bolted to the rear of each I-beam. The remaining two parts of the cart are the boom and boom extender, both of which are used to support the loop antenna in a side-mounted position. The boom, which is also a fiberglass I-beam (fig. 1), straddles the cart and is bolted to both supporting I-beams. The boom extender is bolted to the end of the boom and provides the connecting point for the two sections of the loop antenna. The other two ends of the loop antenna are connected by swivel mounts to the high-voltage electrode and ground plate of the pulser.

3.2 High-Voltage Power-Supply System

The location in the cabinet of the various components of the high-voltage power-supply system can be determined from figure 4. The heavy components--the inverter, high-voltage module, and 12-V battery--are bolted to the bottom of the cabinet or restrained by the various hold-down brackets, which are themselves bolted to the cabinet. The circuit board shown in figure 4 contains the 1-M Ω resistor and the 0.1- μ F capacitor for the meter circuit, as well as the connection terminal for the 500-M Ω resistor. The dielectric tube also is shown in figure 4. The two resistors (R2 and R3) screw into the ball connector. One end of this resistor assembly then screws into the dielectric tube, and the other end attaches to the circuit board. The wiring illustrated in figure 2 must be followed. High-voltage wire must be used in the high-voltage circuit. Figure 5 (p 10) shows the components assembled on the front panel: the Variac, dielectric tube, high-voltage meter and power indicator light, ignition key, mode switch, and fuses.

3.3 Pulser Assembly

The assembly of the pulser is started with the aluminum ground plate (fig. 6).

The SF₆ gas purge-control assembly, high-voltage feed-through connector, SF₆ inlet, and swivel loop antenna connector should already be mounted. If not, then mount them as shown in figure 6, making sure that all penetrations are sealed to withstand at least 1 atm of pressure (SF₆ gas). Slip the clear, plastic dielectric tube over the protruding end of the high-voltage feed-through connector. Then assemble the capacitor stack. This stack is a series parallel arrangement of eight, 2700-pF high-voltage ceramic (button) capacitors. To build up the stack, screw the studded ends of the four capacitors into the four dead-end tapped holes in the end plate. Then screw the four remaining capacitors into these capacitors in the connecting holes shown in figure 6. Slip the connection plate (fig. 7) over the dielectric tube, and attach the plate to the capacitor stack with the four screws provided; screw them into the tapped holes in the ends of the capacitors.

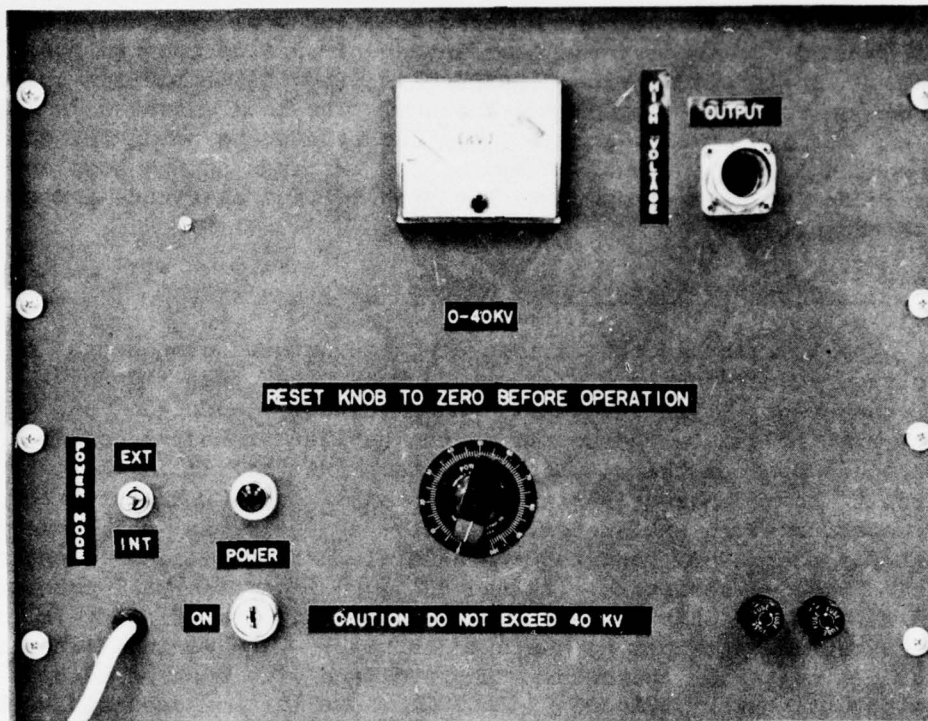

Figure 5. Front panel of high-voltage power-supply system.

Since the end plate and connection plate are aluminum, the capacitors form a series parallel stack that has an equivalent capacitance of 5400 pF. Screw the two load-resistor connectors into the connection plate in the holes provided (fig. 7). Then depress the 100- Ω resistors into these connectors. Press the two beryllium finger connectors over the heads of the resistors. All these connectors have T-slots cut into them so that they may expand and capture the resistors. The beryllium fingers contact the brass electrode plate. Therefore, the resistors are in parallel and form an equivalent 50- Ω resistance. The assembly of the aluminum end plate is now complete.

To assemble the gap housing (fig. 8), attach the SF₆ purge hose to its connector on the gap housing. Slip the small O-ring over the screw end of the adjustable electrode, and then screw the electrode onto the electrode plate. Insert the 3-in. O-ring into the gap housing, and

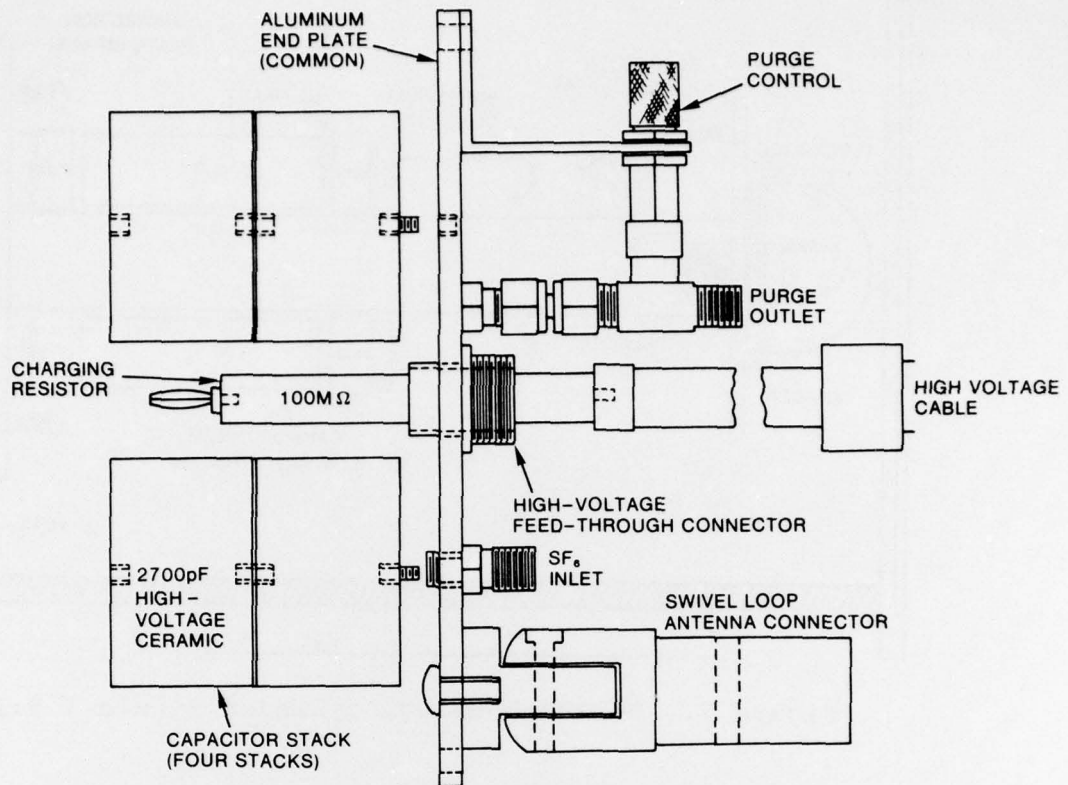

Figure 6. Pulser ground-plate assembly (scale 1.8:1).

then screw the electrode plate assembly onto the Plexiglas gap housing. Make sure that the screws are turned down evenly so that the electrode plate compresses the O-ring and forms a seal. Attach the high-voltage pulse feed-through strap to one of the screws. To assemble the other electrode, insert the contact bolt through the other electrode plate, and then slip the spacer over the bolt. Screw the electrode over the bolt until the whole assembly is tight. Finally, screw the electrode assembly to the gap housing and the gap-housing assembly to the pulser body (fig. 7). Be sure that the high-voltage connector mount is attached to the gap housing.

The aluminum end plate assembly may now be bolted to the pulser body. Take care to insert the purge hose into the interior hole in the bleed valve. Also, take care to slip the dielectric tube over the end of the contact bolt. As with the gap-housing assembly, put the O-ring in place before bolting the aluminum ground plate. The pulser is now assembled and may be bolted to the cart by the two holes in the base plate.

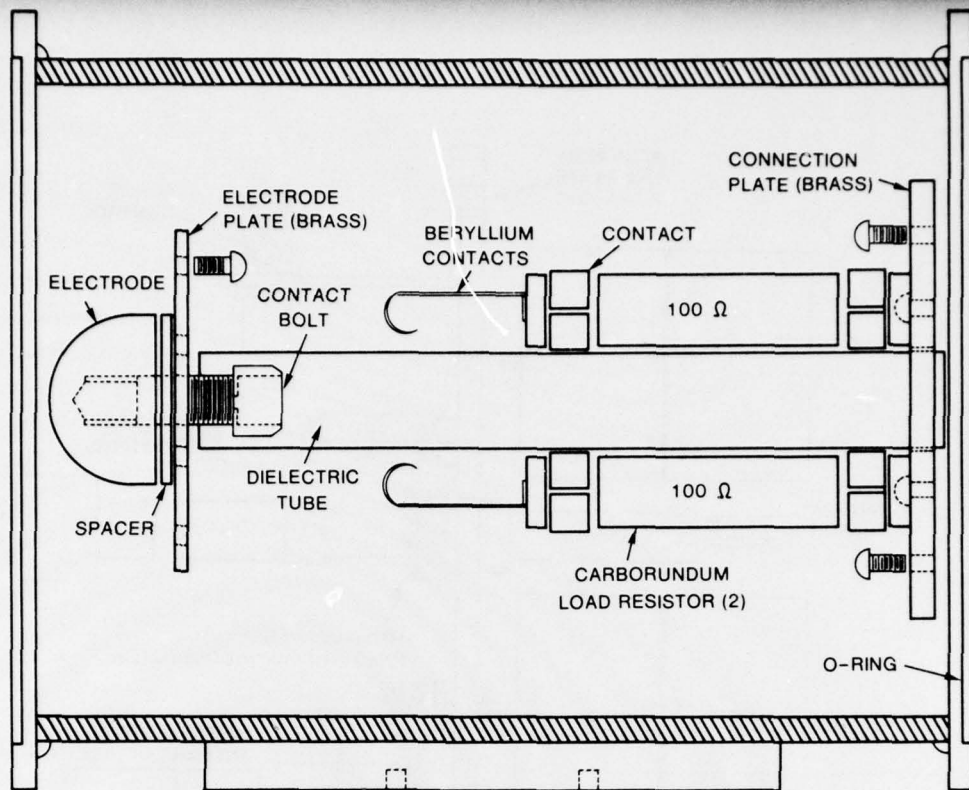

Figure 7. Pulser housing, cylinder (scale 1.8:1).

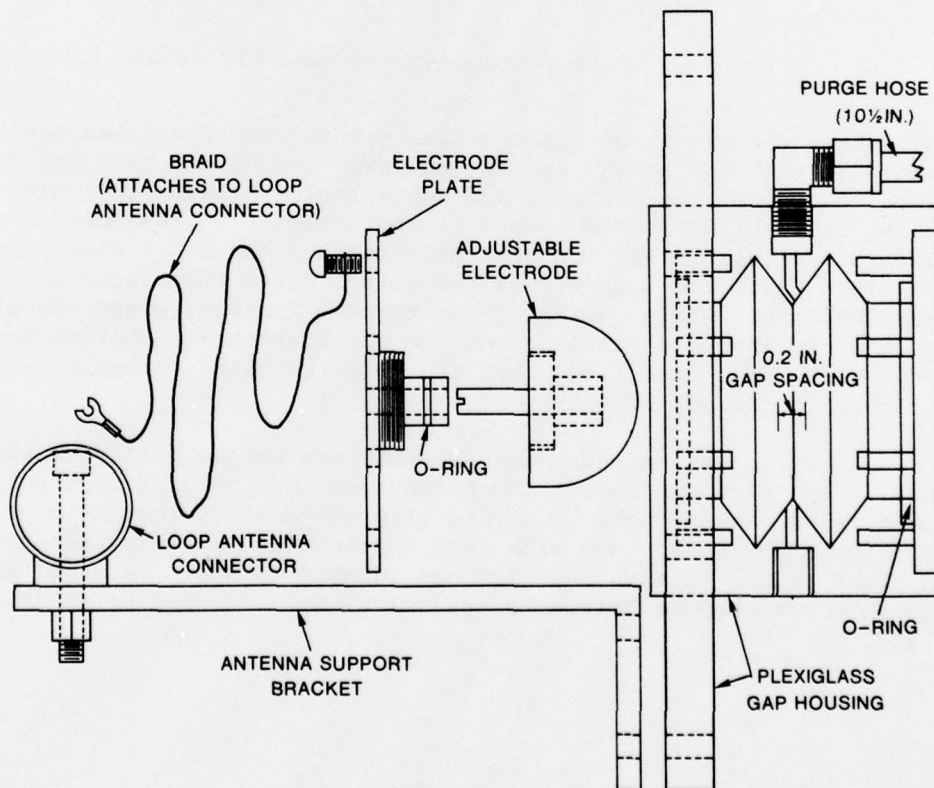

Figure 8 Gap housing assembly (scale 1.8:1).

4. ASSEMBLY OF PLACER

To assemble the PLACER, place the high-voltage supply module upon the cart in a convenient position. Then place the SF₆ gas bottle with a regulator and hose into the shielded cavity. Connect the high-voltage line to the pulser. Take care with the 10-MΩ resistor screwed onto the end of the cable: insert the resistor properly through the dielectric tube into the contact bolt without damaging the cable. Attach the SF₆ gas line to the end plate at the SF₆ inlet. The PLACER is now assembled.

5. TURN-ON PROCEDURE

Follow this procedure for making the PLACER operational:

- a. Close the purge valve on the end plate.
- b. Open the regulator valve and allow the pressure to build up to 12 to 14 psi.
- c. Open the purge valve on the pulser for approximately 5 s to purge the pulser and hose of air.
- d. Close the purge valve until just the slightest pressure of gas is felt when a finger is placed over the purge valve and held there for several seconds.
- e. Make sure that the Variac is turned completely down.
- f. Connect the battery to the inverter.
- g. Close and latch the rear door of the power-supply module.
- h. Make sure that the mode switch is in internal position.
- i. Turn on the ignition lock.
- j. Adjust the Variac until the pulser is operating at 26 kV and pulsing about once every 2 to 2.5 s. Adjust the gas pressure, if necessary, to obtain these conditions.

6. CHARGING PROCEDURE FOR 5-LB BOTTLE OF SF₆

- a. Make certain that all valves on the 235- and 5-lb bottles are closed. Also, check the safety valve on the side of the 5-lb bottle.

b. Invert the 235-lb bottle of SF_6 , and lay it on its side (fig. 9).

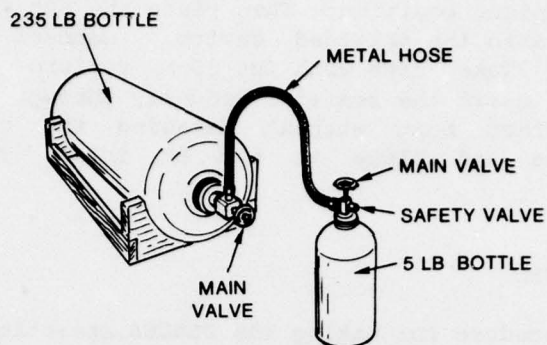

Figure 9. Setup for charging SF_6 bottle.

- c. Stand the 5-lb bottle upright.
- d. Connect a metal hose between the bottles.
- e. With one or two turns, open the safety valve on the side of the 5-lb bottle.
- f. Open the main valve of the 5-lb bottle.
- g. Open the main valve of the 235-lb bottle.
- h. Refill the 5-lb bottle until a white vapor appears around the safety valve.
- i. Close the safety valve on the 5-lb bottle.
- j. Close the main valve on the 235-lb bottle.
- k. Crack the valve on the metal hose just enough to depressurize the line.
- l. Close off the main valve to the 5-lb bottle while depressurizing the line.
- m. Disconnect the metal hose from both bottles and store it.
- n. Connect the regulator to the 5-lb bottle.

7. PLACER CALIBRATION CHECK

Before using the PLACER, follow this calibration procedure to insure that the PLACER is operating properly:

a. Set up the shielded instrumentation box with equipment inside (fig. 10).

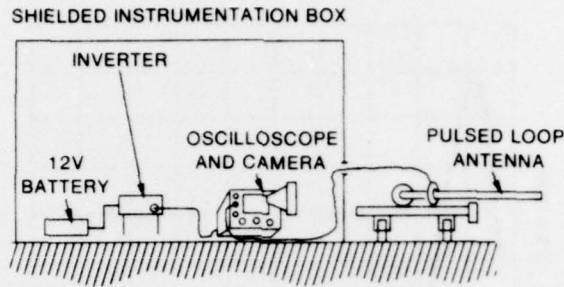

Figure 10. Test setup for loop antenna current calibration.

b. Connect the current probe (Singer model 94606-4) to the loop antenna on the ground side of the pulser.

c. Connect the cable from the probe to the feed-through connector on the shielded instrumentation box. Connect the cable from the feed-through connector to the input of the oscilloscope. Use a $50\text{-}\Omega$ termination at the input to the oscilloscope. If a Tektronix model 485 oscilloscope is used, a $50\text{-}\Omega$ input switch is provided.

d. Set up the PLACER to operate at 26 kV and turn it on (sect. 5).

e. The current pulse will be sensed by the current probe and fed to the oscilloscope; the oscilloscope operator can then center the trace and capture the leading edge of the signal by adjusting the trigger control. Set the vertical amplitude at 0.5 V/division , and set the horizontal sweep to 500 ns/division . *Caution:* The variable controls for both the vertical and horizontal amplifiers must always be in the "calibrated" position.

f. Photograph the waveform. Several pictures may have to be taken to get the proper settings of f stop and speed. Set the camera on manual shutter control. Estimate the timing of the repetitive pulse; the shutter must be opened before the signal appears and closed before the next pulse appears. The waveform should fill about $1/2$ the vertical graticule and the entire width of the waveform should be captured within the horizontal graticule. The graticule and trace should be clearly

visible in the picture, but should not be overexposed. The baseline also should be visible at the beginning of the trace (fig. 11). The peak current in the loop should be at least 320 A. If a Singer model P3686-4m is used, the peak voltage will be 2.2 V or greater for adequate loop current.

- g. Remove the loop antenna current probe from the loop antenna.

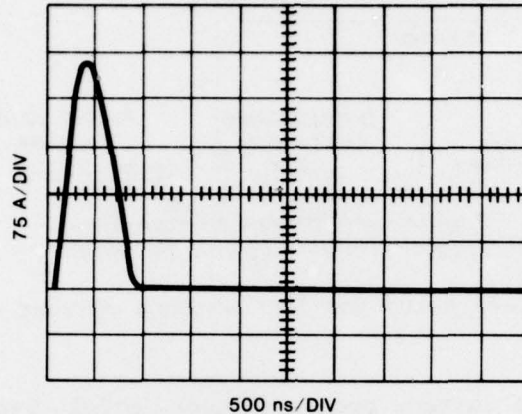

Figure 11. Loop antenna current.

8. PROCEDURE FOR FLAW LOCATION

The electromagnetic field is produced by the PLACER positioned on the ground above the conduit. The field from the loop is very localized; hence, a flaw can be detected only if the loop is near the conduit. From one end of the conduit bank to the other and on both sides of the bank, move the PLACER along the ground above the conduit. Special bipolar, level sensing detectors (or oscilloscopes) are connected to Singer current probes clamped around the cable bundles coming from 4 to 12 of the conduits depending on channel capacity. If a current is detected in any of the cable bundles while the conduit bank is being "swept," mark the approximate ground location. Upon completion of the rapid sweep, replace the level detectors on flawed conduits by oscilloscopes, and move the loop in small increments over the flaw area to determine the exact location which produces the maximum current (that is, the location of the flaw). Figure 12 shows the test operation.

Since the PLACER system is a field unit and must be broken down into its component parts to be transported, a checklist (table I) is useful when packing.

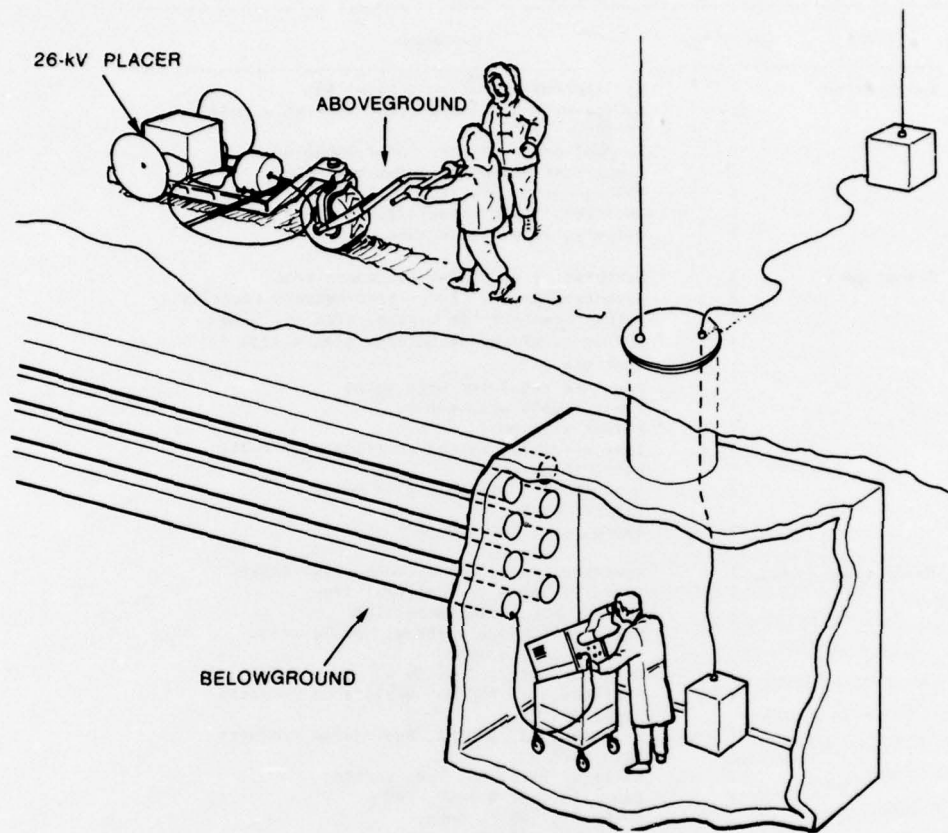

Figure 12. Flaw location technique for PLACER.

TABLE I. CHECKLIST FOR PLACER

Use	Quantity	Equipment
Calibration	1	Oscilloscope, Tektronix model 485
	1	Camera with bezel and film, Tektronix model C-3100C-32
	1	Current probe, Singer model P3686-4m
	1	Electric-field measurement box, HDL
	1	Voltage probe, Tektronix, P6045
	1	Inverter, Topaz, model 250-CW-12-24-60
	1	Battery, 12 V, truck type
	Placer part	3
2		Battery charger, 12 V, three-battery capacity
2		Sulfur hexafluoride bottle, size 1A, 5 lb
1		Sulfur hexafluoride bottle, size 4, 235 lb
1		Tool kit
1		Pressure regulator with hoses
1		Power supply with cables
1		Pulser with bolts
1		Loop assembly, set of sections with bolts
1		Cart, three wheel
1		Loop support assembly with bolts
1		Handle, cart
1		Spare parts kit (pulser)
Power supply part	1	Inverter, Nova, 125 W, model 2560-125WUV
	1	Battery, Sears recreational type
	1	Variac, power stat model 10B
	1	Switch, S1, double throw, double pole, center off, toggle
	1	Resistor, R1, 1/2 W, 56 k Ω
	1	Resistor, R2, 100 M Ω , Resistance Products type BFT
	1	Resistor, R3, 500 M Ω , Resistance Products type BFT
	1	Resistor R4, 1 M Ω , 1 W, carbon
	1	Capacitor, C1 0.1 μ F, 100 V
	1	Bulb, L1, 100 V, neon
	1	Meter, M1 100 μ A
	1	Module, 40 kV, Del Electronics, model 40-1-1
	5	Fuses, F1, 1-1/2 A; F2, 3/4 A; SLO-BLO

APPENDIX A.--ABOVEGROUND ELECTRIC FIELD PRODUCED BY THE PLACER

A-1. INTRODUCTION

The following data were presented to the Nuclear Weapons Systems Safety Command Committee prior to the August 1976 Protection Integrity Maintenance (PIM) Test at the Safeguard site at Grand Forks, ND, so that the safety and security of the Pulsed Loop Antenna Conduit Electromagnetic Radiator (PLACER) system could be evaluated.

A-2. MAXIMUM POWER DENSITY OF THE PLACER UNDER NORMAL AND FAILURE CONDITIONS

The maximum power density under normal operating conditions is $0.016 \times 10^{-6} \text{ W/cm}^2$. It has been assumed that all the energy stored on the charging capacitor (5400 pF) is radiated. The operating voltage is considered to be 30 kV, the repetition rate is 2.5 s, and the density is calculated at 100 ft (30 m) from the loop antenna. The antenna is considered to have a 3-dB gain in a preferred direction (magnetic dipole).

The maximum power density under failure conditions is $1.08 \times 10^{-6} \text{ W/cm}^2$. It is assumed that all the energy stored on the capacitor is radiated. The maximum operating voltage is considered to be 50 kV, the repetition rate is 1 s, and the density is calculated at 100 ft (30 m) from the loop antenna. The antenna is considered to have a 3-dB gain in the preferred direction (magnetic dipole).

For the failure condition to arise, the following events must occur:

- a. The Variac must be turned on full.
- b. The spark-gap pressure or spacing (or both) must be increased for a 50-kV breakover voltage.
- c. The 100-M Ω charging resistor must have decreased by 75 percent (20 to 30 percent typically).

Table A-I shows field strengths as measured 2 ft (0.6 m) aboveground. The field strengths were produced by the loop antenna current shown in figure 11 in the main body of the report. The loop antenna current was monitored periodically during the test to insure constant field conditions. The test setup shown in figure A-1 was used to measure the field components.

APPENDIX A

TABLE A-1. PEAK AMPLITUDES OF THREE ORTHOGONAL COMPONENTS OF ELECTRIC FIELD PRODUCED BY PLACER (OPERATED AT 32 kV)

Distance (ft)	Electric-field component		
	E_x (V/m)	E_y (V/m)	E_v (V/m)
10	1064	2736	5776
30	45.6	60.8	91.2
50	18.24	30.4	45.6
100	9.12	12.16	15.2
300	1.37	--	4.56
500	0.91	--	2.73

E_v IS VERTICAL COMPONENT

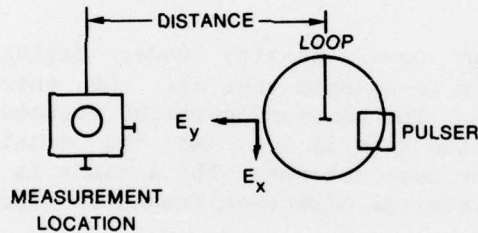

Figure A-1. Pulser.

A-3. VULNERABILITY STATEMENT

The Harry Diamond Laboratories (HDL) loop antenna used for the PIM conduit testing induces significant currents onto cables only at close range, that is, within 50 ft (15 m). The loop-induced currents have the characteristic waveform shown in figure A-2, which displays a typical time-domain conduit current and its Fourier transform.

During the first PIM conduit testing at the Safeguard site, there were a number of long power cables lying on the collocated missile field. Therefore, prior to the PIM test, an experiment was conducted at HDL to determine the maximum current that the PLACER could induce on a ground-level cable. For a 100-ft (30 m) length of 1-in. (2.54-cm) diameter cable at ground level, the maximum current that could be induced onto the cable at an operating voltage of 30 kV was 6 A. For the maximum voltage of 50 kV, this current would have been 10 A.

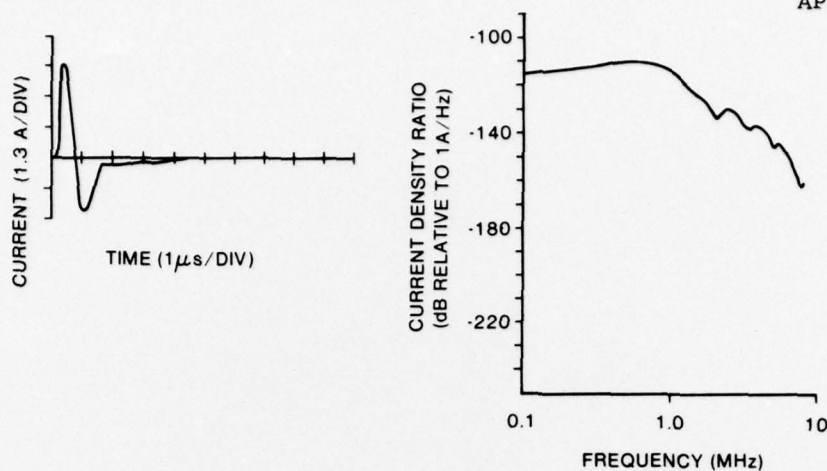

Figure A-2. Typical conduit current induced by PLACER.

Measurements at the Safeguard site have shown that, at the operating voltage of 30 kV, the HDL loop can induce a peak current of 4 A on the most exposed conduit--that is, a single conduit at the normal depth of approximately 10 ft (3 m). If this conduit were completely broken, then the 4 A would be shared between the interior cables. For the launch enable (LE) and status and order (SO) conduits, which have the fewest number of cables (that is, 1 LE cable and 1 SO cable), each cable would carry 2 A since the two cables have approximately the same diameter. At a voltage of 50 kV, this cable current would be $2 \times 50/30 = 3$ A. But 3 A of the HDL loop-induced current is more than one order of magnitude less (at all frequencies) than the current required by the weapon system contractor to determine upset or damage.¹

¹Ground Electromagnetic Pulse Effect, Vol. 1, Martin Marietta Report OR 13,016, Orlando, FL, (April 1974), 5-7.

DISTRIBUTION

DEFENSE DOCUMENTATION CENTER
CAMERON STATION, BUILDING 5
ALEXANDRIA, VA 22314
ATTN DDC-TCA (12 COPIES)

COMMANDER
USA RSCH & STD GP (EUR)
BOX 65
FPO NEW YORK 09510
ATTN LTC JAMES M. KENNEDY, JR.
CHIEF, PHYSICS & MATH BRANCH

COMMANDER
US ARMY MATERIEL DEVELOPMENT
& READINESS COMMAND
5001 EISENHOWER AVENUE
ALEXANDRIA, VA 22333
ATTN DRXAM-TL, HQ TECH LIBRARY

COMMANDER
USA ARMAMENT COMMAND
ROCK ISLAND, IL 61201
ATTN DRSAR-ASF, FUZE DIV
ATTN DRSAR-RDF, SYS DEV DIV - FUZES

COMMANDER
USA MISSILE & MUNITIONS CENTER & SCHOOL
REDSTONE ARSENAL, AL 35809
ATTN ATSK-CTD-F

COMMANDER
US ARMY ENGINEER DIV, HUNTSVILLE
P.O. BOX 1600, WEST STATION
HUNTSVILLE, AL 35807
ATTN MR. T. BOLT

COMMANDER
AF WEAPONS LABORATORY, AFSC
KIRTLAND AFB, NM 87117
ATTN J. DARRAH

COMMANDER
USA SAFEGUARD COMMUNICATIONS AGENCY
FORT HUACHUCA, AZ 85613
ATTN SAFCA-SSA-AN, COL TATE
ATTN SAFCA-MCCX-SSA, L. BLUMBERG

COMMANDER
USA BALLISTIC MISSILE
DEFENSE SYSTEMS COMMAND
P.O. BOX 1500
HUNTSVILLE, AL 35807
ATTN BMDSC-WSE, COL WAYNE D. MILLER
ATTN BMDSC-WSE, MR. JOHN WEIMER (5 CY)
ATTN BMDSC-WSE, MR. TOM YATES
ATTN BMDSC-WSE, MR. R. M. MOORE
ATTN BMDSC-TEN, MR. R. DEKALB

COMMANDER
USN ELECTRONICS LABORATORY CENTER
SAN DIEGO, CA 92152
ATTN T. HORWORTH

DIRECTOR
BALLISTIC MISSILE DEFENSE
PROGRAM OFFICE
1300 WILSON BLVD
ARLINGTON, VA 22209
ATTN MR. J. SHEA

COMMANDER
USA SAFEGUARD SYSTEM EVALUATION AGENCY
WHITE SANDS MISSILE RANGE, NM 88002
ATTN SSEA, DR. D. COLLIER

DIRECTOR
CONSTRUCTION ENGINEERING
RESEARCH LABORATORY
P.O. BOX 4005
CHAMPAIGN, IL 61820
ATTN D. LENERENZ
ATTN R. MCCORMACK

HARRY DIAMOND LABORATORIES
ATTN MCGREGOR, THOMAS, COL, COMMANDER/
FLYER, I.N./LANDIS, P.E./
SOMMER, H./OSWALD, R. B.
ATTN CARTER, W.W., DR., TECHNICAL
DIRECTOR/MARCUS, S.M.
ATTN KIMMEL, S., PAO
ATTN CHIEF, 0021
ATTN CHIEF, 0022
ATTN CHIEF, LAB 100
ATTN CHIEF, LAB 200
ATTN CHIEF, LAB 300
ATTN CHIEF, LAB 400
ATTN CHIEF, LAB 500
ATTN CHIEF, LAB 600
ATTN CHIEF, DIV 700
ATTN CHIEF, DIV 800
ATTN CHIEF, LAB 900
ATTN CHIEF, LAB 1000
ATTN RECORD COPY, BR 041
ATTN HDL LIBRARY (3 COPIES)
ATTN CHAIRMAN, EDITORIAL COMMITTEE
ATTN CHIEF, 047
ATTN TECH REPORTS, 013
ATTN PATENT LAW BRANCH, 071
ATTN GIDEP OFFICE, 741
ATTN LANHAM, C., 0021
ATTN CHIEF, BR 1040
ATTN CHIEF, BR 1050
ATTN AGEE, F. J., 1040 (20 CY)
ATTN ROBERTS, H. A., 1040 (20 CY)
ATTN GOODWIN, D., (5 CY)

