

AD-A040 032

UNITED TECHNOLOGIES RESEARCH CENTER EAST HARTFORD CONN F/G 21/5
LIGHTWEIGHT PROPULSION SYSTEMS FOR ADVANCED NAVAL SHIP APPLICAT--ETC(U)
MAY 77 S C KUO

N00014-76-C-0542

UNCLASSIFIED

UTRC/R77-952566-5

NL

1 of 3

AD
A040032

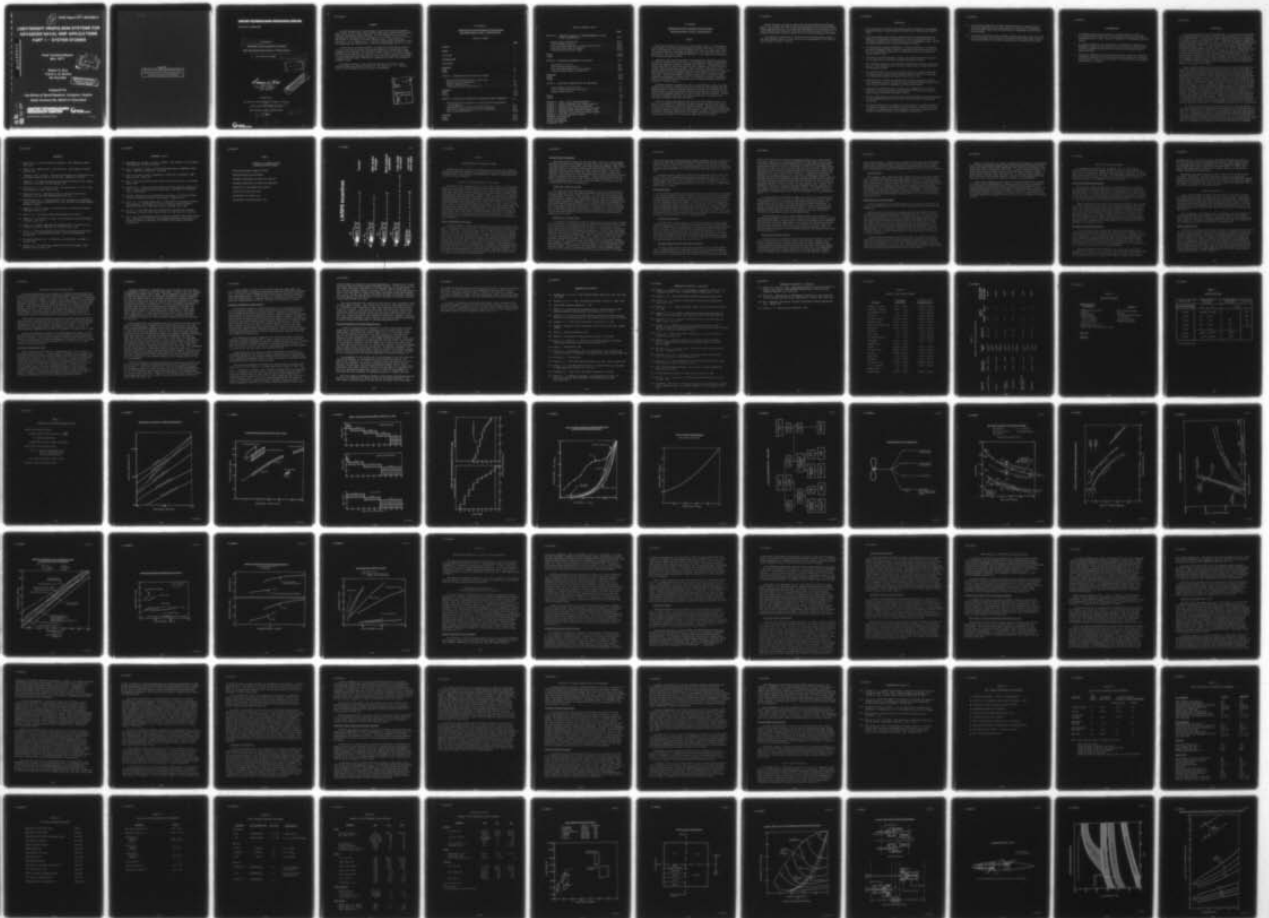

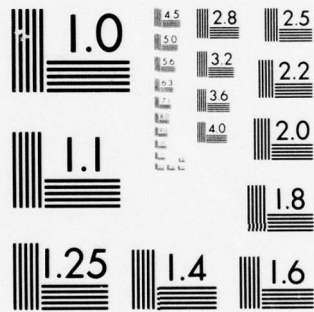

MICROCOPY RESOLUTION TEST CHART
NATIONAL BUREAU OF STANDARDS-1963-A

P
B.S.

UTRC Report R77-952566-5

**LIGHTWEIGHT PROPULSION SYSTEMS FOR
ADVANCED NAVAL SHIP APPLICATIONS
PART I - SYSTEM STUDIES**

ADA 040032

**Final Technical Report
May 1977**

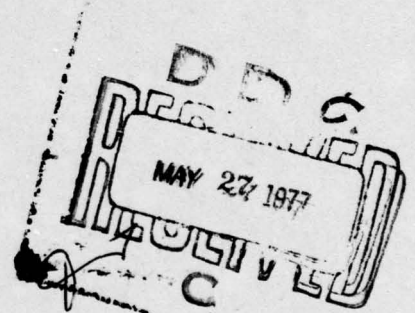

**Simion C. Kuo
Travis L. O. Horton
Ho-Tien Shu**

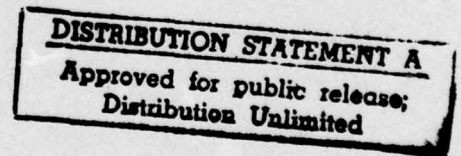

**Prepared for
The Office of Naval Research, Arlington, Virginia
Under Contract No. N00014-76-C-0542**

**AD No. _____
DDC FILE COPY**

**UNITED TECHNOLOGIES
RESEARCH CENTER**



**UNITED
TECHNOLOGIES**

EAST HARTFORD, CONNECTICUT 06108

77-05-78-1

NOTICE

APPROVED FOR PUBLIC RELEASE; DISTRIBUTION UNLIMITED.
REPRODUCTION IN WHOLE OR IN PART IS PERMITTED FOR ANY
PURPOSE OF THE UNITED STATES GOVERNMENT.

UNITED TECHNOLOGIES RESEARCH CENTER

East Hartford, Connecticut 06108

- 14 UTRC / R77-952566-5 ✓
- 6 Lightweight Propulsion Systems for Advanced Naval Ship Applications, -- Part I, -- System Studies
- 9 Final Technical Report, Apr 76 - May 77

DDC
RECEIVED
MAY 27 1977

Simon C. Kuo

10 Simon C. Kuo
Principal Investigator
(203) 565-8758

DISTRIBUTION STATEMENT A
Approved for public release;
Distribution Unlimited

Prepared for:

The Office of Naval Research, Arlington, Virginia

Under Contract No. 15 N00014-76-C-0542 *New*

LCDR William R. Seng, Program Monitor

11 May 1977

12 286P.

409252



FOREWORD

The work described herein was performed by the United Technologies Research Center (UTRC) for the Office of Naval Research (ONR) under Contract N00014-76-C-0542 during the period April 1976 to May 1977. Included among those who assisted in performing this work were Messrs. S. Dolinger, T. L. O. Horton, and Dr. H. T. Shu of UTRC and Mr. F. H. Boenig of the Power Systems Division, United Technologies Corporation. Drs. P. Mandel and P. C. Bertelson provided expert assistance on naval ship requirements and characteristics. The UTRC Program Manager was Dr. S. C. Kuo.

A field trip to the Federal Republic of Germany and Switzerland was made by Dr. Kuo in July 1976 to discuss the latest developments in turbomachinery, high-temperature heat exchangers, and other technologies crucial to the study program. Contributions by Professor R. T. Schneider of the University of Florida in arranging the trip itinerary and participating in the discussions are gratefully acknowledged. A comprehensive UTRC Report, R76-952566-2, summarizing the major trip findings was submitted to ONR.

The Technical Monitor of the program for ONR was LCDR William R. Seng. Valuable guidance and comments received from LCDR Seng and Mr. J. A. Satkowski, Director, Power Program at ONR are gratefully acknowledged.

ACCESSION BY	
NTIS	Write Section <input checked="" type="checkbox"/>
OCC	Duff Section <input type="checkbox"/>
UNANNOUNCED	<input type="checkbox"/>
JUSTIFICATION	
BY	
DISTRIBUTION/AVAILABILITY CODES	
Dist.	AVAIL. and/or SPECIAL
A	

R77-952566-5

Lightweight Propulsion Systems for Advanced Naval
Ship Applications -- Part I - System Studies

TABLE OF CONTENTS

	<u>Page</u>
FOREWORD	i
SUMMARY	1
CONCLUSIONS	3
RECOMMENDATIONS	5
INTRODUCTION	6
REFERENCES	9
TABLE	11
FIGURE	12
SECTION I - CHARACTERIZATION OF PROPULSION SYSTEMS	I-1
Selection and Characterization of Naval Ships	I-1
Typical Duty Cycle Requirements	I-7
Thruster Characteristics	I-8
Transmission Type and Characteristics	I-11
REFERENCES	I-16
TABLES	I-19
FIGURES	I-26
SECTION II - SELECTION AND DEFINITION OF PROPULSION PLANT ALTERNATIVES . .	II-1
Identification and Integration of Propulsion System Requirements and Assumptions	II-1
Identification of Critical and Projected Technology	II-6
Selection of Propulsion System Sizes and Arrangements	II-16
Scope of System Evaluation	II-18
REFERENCES	II-19
TABLES	II-20
FIGURES	II-30

TABLE OF CONTENTS (Cont'd)

	<u>Page</u>
SECTION III - PARAMETRIC ANALYSIS OF SYSTEM PERFORMANCE, SIZE AND WEIGHT CHARACTERISTICS	III-1
Baseline Cycle Configurations	III-1
Cycle Performance Analysis	III-2
Power Conversion System Size and Weight Characteristics	III-6
Propulsion System Trade-off Analysis	III-11
Propulsion System-Plus-Fuel Weight	III-12
TABLES	III-16
FIGURES	III-22
SECTION IV - PRELIMINARY ENGINEERING COST ANALYSIS	IV-1
Significant Cost Factors	IV-1
Cost Estimating Methodologies	IV-4
Power Conversion System Cost Characteristics	IV-8
Propulsion System Capital and Fuel Costs	IV-9
REFERENCES	IV-11
TABLES	IV-12
FIGURES	IV-21
SECTION V - OPERATIONAL CHARACTERISTICS AND LIMITATIONS	V-1
Fuel Consumption Characteristics	V-1
Control Characteristics and Limitations	V-4
Response Characteristics	V-14
TABLES	V-17
FIGURES	V-19
APPENDIX A - SURVEY OF SHIP POWER REQUIREMENTS	A-1
APPENDIX B - THRUSTOR PERFORMANCE AND WEIGHT ESTIMATION	B-1
APPENDIX C - GEARBOX WEIGHT AND VOLUME ESTIMATION	C-1
APPENDIX D - PROPULSION SHAFT WEIGHT ESTIMATION PROCEDURE	D-1
APPENDIX E - STATE-OF-THE-ART PERFORMANCE PROGRAM (SOAPP)	E-1
APPENDIX F - COMPONENT SIZE AND WEIGHT ESTIMATING PROGRAM	F-1
APPENDIX G - CCGT COST ESTIMATING PROGRAM	G-1
REFERENCES FOR APPENDICES	RA-1
TABLES FOR APPENDICES	TA-1
FIGURES FOR APPENDICES	FA-1
DISTRIBUTION LISTS	DL-1

R77-952566-5

Lightweight Propulsion Systems for Advanced Naval
Ship Applications -- Part I - System Studies

SUMMARY

This report presents the results of system studies as part of a comprehensive study program to evaluate the technological and economic feasibility of utilizing open- and closed-cycle gas turbines integrated with fossil or nuclear heat sources for providing advanced lightweight propulsion power for future Navy capital ship applications. The level of technology considered is that judged by the Contractor to be available during the 1990's.

Naval ship types which could benefit from implementing lightweight propulsion systems were selected and characterized, and performance and weight characteristics for selected propulsion machinery components were estimated. Turbomachinery technologies applicable to naval ship propulsion were reviewed, and future advances in crucial technical areas were projected. Eight reference installed power levels between 40,000 and 300,000 shp applicable to the ship types considered were selected. Basic propulsion system arrangements compatible with component capabilities were identified. From the huge number of possible combinations of propulsion system components, arrangements, and power levels for different ship types, a manageable number of practical cases were selected by use of a matrix screening process and subjected to detailed study.

Extensive parametric analyses were made of the performance, weight, and volume characteristics for the propulsion engine cycles selected. Refined weight and performance predictions for the baseline engines selected were then combined with the characteristics of selected gearboxes, shafting, and thrustors to estimate the propulsion system equipment weight for the over 400 cases selected previously. Systems with lowest equipment weight were then identified for each of the power levels required for different ship types considered.

The total propulsion-system-plus-fuel weight was then estimated based on the duty cycles identified for different ship types, assuming reasonable heat source specific weight ranges for sensitivity analysis purposes. The results are given in a form which allows the minimum total weight system to be identified for combinations of desired endurance or range and heat source specific weight for different ship types considered. The payload capabilities and endurance limitations resulting from different propulsion systems for selected ship types were also identified.

R77-952566-5

Factors critical to propulsion engine cost were investigated and preliminary capital cost estimates were made for the baseline engines as well as the propulsion system components selected. The operational characteristics and limitations for the lightweight propulsion systems utilizing open- and closed-cycle gas turbines were studied from the power conversion system as well as the ship propulsion view points.

The program was conducted by the Energy Conversion Systems Analysis group of UTRC under Contract N00014-76-C-0542 from the Power Program Branch of the Office of Naval Research, Arlington, Virginia.

CONCLUSIONS

1. Both the open- and closed-cycle gas turbines offer the potential of lightweight propulsion systems for improving mission capabilities of advanced Navy capital ships.
2. With fossil fueling, open-cycle gas turbines offer the least engine-plus-fuel weight for short-endurance (approximately 50 hours) ship missions, while the closed-cycle turbines would be more attractive for long-endurance ships. However, the weight difference at all practical endurances are small.
3. For ship missions exceeding approximately 100 hours endurance, a closed-cycle gas turbine integrated with a suitable lightweight nuclear reactor heat source, would be significantly lighter than any fossil-fueled open- or closed-cycle engine-plus-fuel system.
4. Utilization of aircraft-derivative (rather than industrial) engine technology will be imperative in developing lightweight propulsion systems.
5. For closed-cycle systems to be attractive, the heat source specific weight will have to be less than about 6 and 15 lb/shp, respectively, for fossil-fired and nuclear-powered systems.
6. The estimated capital cost for closed-cycle systems is noticeably higher than for open-cycle gas turbine systems. However, savings in fuel cost and longer life expectancy could make this system lifecycle cost lower.
7. Regenerative and intercooled closed-cycle gas turbines operating at turbine inlet temperatures between 1500 and 1700 F and pressures between 580 and 840 psia would be most suitable for lightweight propulsion applications.
8. Closed-cycle technology for 1550 F turbine inlet temperature at 40,000-hour lifetime is currently available, while achieving a 1700 F level by 1990 would appear feasible with modest development efforts.
9. Potential improvements in closed-cycle gas turbine performance will be constrained by the temperature capability of the heat source rather than turbomachinery limitations.
10. Although technology for unit capacity up to 600,000 shp is currently available, the baseline closed-cycle gas turbines would be limited to 200,000 shp as constrained by the gearbox and thruster capabilities; open-cycle engines would be limited to 50,000 shp because of system design considerations.

11. A closed-cycle engine with two power turbines driving two thrusters, and two open-cycle engines driving one thruster are two promising basic arrangements. The former would benefit from the availability of lightweight electric transmission systems.
12. The concept of standardized heat exchanger elements using small tubes could reduce the heat exchanger size and weight; the selection between wrap-around vs distributed layout remains to be decided through detailed conceptual design studies.

RECOMMENDATIONS

1. A conceptual design should be made for a reference propulsion engine to provide detailed data needed for the subsequent reliability and life-cycle cost analyses and an overall feasibility assessment for lightweight propulsion systems.
2. An intensive parametric design study should be undertaken to estimate the performance, weight and cost characteristics of selected gas (helium) heater concepts to evaluate the practicality of achieving the allowable specific weight identified.
3. The crucial components and key technologies needed to demonstrate a practical lightweight closed-cycle gas turbine propulsion system should be identified, and the levels of effort and time required for the most effective development program should be estimated.

INTRODUCTION

The mission capabilities and cost effectiveness of a particular naval ship type often depend greatly on the specific weight and cost characteristics of the propulsion systems utilized. For Navy ships, lighter propulsion systems can be beneficial in a variety of ways as illustrated in Fig. 1. These include improved strategic and tactical operational capabilities resulting from increased speed and/or endurance time, increased payload or reduction in ship size and cost, as well as independence from refueling in foreign ports. Interest in specific ship systems which can provide these benefits has heightened recently (Refs. 1, 2, 3, 4 and 5), stemming partly from a better understanding of the impact that a lightweight propulsion system will have on ship mission, payload, and costs, and partly from skyrocketing fuel prices together with uncertainties in the future oil supply situation (Refs. 6 and 7). For Navy planners to successfully meet future challenges, understanding the potential for lightweight propulsion systems, their technological and economic feasibility and the level of effort and time required to bring about a practical system would appear to be an urgent issue indeed.

Naval propulsion systems have traditionally relied on steam turbines and Diesel engines while open-cycle gas turbines have long been recognized to offer simple, quiet, and responsive propulsion power (Refs. 8, 9 and 10). However, specific fuel consumption and/or durability of the first-generation aircraft-derivative engines when operated in the naval environment, often proved to be deterring considerations. Future marine gas turbines, such as the Pratt & Whitney Aircraft Group FT9 and the General Electric LM5000, will have to be still more efficient and reliable yet maintain the same or lower specific weight and allow operation on fuels other than high-grade distillate oils, e.g., coal-derived liquids. In this context the closed-cycle gas turbine appears to offer considerable advantages since it is more easily adaptable to various heat sources and may offer better turbomachinery durability because internal components are not exposed to the marine air and fuel environment. In addition (see Table I), closed-cycle gas turbines offer compact size and large unit capacity; the thermal efficiency should be equal to or better than that attainable by second-generation open-cycle engines. Its excellent part-load efficiency would allow a much better overall fuel use rate. Finally, the possibility of integrating a closed-cycle gas turbine with an advanced nuclear heat source to offer improved payload capability and the kind of fuel independence desired should not be overlooked.

The fossil-fired closed-cycle gas turbine concept is not new; experimental work on air heaters and air turbomachinery was undertaken prior to 1940 and, by 1955, there were fourteen plants being built or in operation for land-based applications (Ref. 11). Although many of these and several subsequent plants have been operating reliably, with some accumulating over 110,000 hours (Ref. 12), the reliability of lightweight closed-cycle propulsion engines operating in the marine environment aboard high-speed ships will definitely suffer as with the open-cycle engines (Refs. 13, 14, and 15). Furthermore, the closed-cycle gas turbines envisioned for lightweight

propulsion application would operate at turbine inlet temperatures in the range between 1500 F and 1700 F, well above existing plant temperatures, which are limited to approximately 1300 F because of metallurgical limits of the heater tube walls. These increased turbine inlet temperatures would also contribute to additional uncertainties regarding system reliability and, to a lesser degree, economic characteristics (Refs. 16 and 17). It should be mentioned here that despite several conceptual design studies attempted in the past (Refs. 18 and 19), no practical closed-cycle propulsion engine has ever been installed and operated aboard a ship, and thus marine operational experience is totally lacking. Unlike the land-based constant-speed power plants (Refs. 20, 21, 22, and 23), turbomachinery designs for the closed-cycle propulsion system must be harmonized with the transmission type as well as the thruster operating requirements, particularly in terms of shaft RPM which represents another variance from the land-based powerplants in terms of performance, weight, reliability, and economic characteristics.

Therefore, as the first part of an ONR-sponsored study program to assess the technological feasibility and reliability and economic characteristics of utilizing closed-cycle gas turbines integrated with fossil or nuclear heat sources to provide propulsion power for future advanced naval ship applications, a parametric system analysis was conducted to characterize the performance, size, weight and cost of selected open- and closed-cycle gas turbine systems. The relative impact that these characteristics will have on selected ship mission capabilities, such as payload fraction and endurance time, were also predicted. This part of the study assimilated the varied requirements and projections for the capabilities of candidate propulsion systems with different ship types of various sizes and speeds which require such exceptional high installed power, long durability, or low engine plus fuel weight to make the closed-cycle gas turbines an outstanding candidate. The technologies for the turbomachinery and other propulsion system components were considered to have reasonable progress from the state of the art but without entirely new or unproven concepts which require "crash" or massive development to mature before the 1990's.

The results of Part I - System Studies are presented in this report in five sections. Detailed analytical procedures are contained in seven appendices which follow. Section I describes the size, speed, installed power, and duty cycle characteristics identified for the selected ship types considered in the study; the weight characteristics estimated for the thrusters, gearboxes and shafting selected are also presented. Section II describes the general requirements and constraints assumed for the lightweight propulsion system, and a review of the open- and closed-cycle gas turbine technologies and future projections; the baseline engines and alternative propulsion system configurations selected, and a summary of assumptions made for the component capabilities are also presented in this section. Section III presents the results of extensive parametric cycle analysis and weight estimates for selected open- and closed-cycle gas turbines; the engine plus fuel weight estimated for different ships and their impact on the ship payload capabilities for various endurance requirements are also presented here. Section IV presents the results of cost estimates for the turbomachinery as well as the total propulsion systems, while the operational characteristics for the candidate lightweight propulsion systems are described in Section V. Appendices A through G describe the

R77-952566-5

ship survey results, the state-of-the-art performance program for propulsion engines, the component weight estimating programs for turbomachinery, gearboxes, thrustors, and shafting, and the cost estimating programs for the power conversion systems.

REFERENCES

1. Rainey, P. G.: Basic Ocean Vehicle Assessment. Naval Engineers Journal, April 1976.
2. Kehoe, J. W.: Warship Design - Ours and Theirs. Naval Engineers Journal, February 1976.
3. Goldman, R. and R. Peterson: Planning and Development for a New Generation of Gas Turbine Propelled Ships in the U.S. Navy. ASME Paper 74-GT-158.
4. Chaplin, J. B.: Amphibious Surface Effect Vehicle Technology, Past, Present, and Future. AIAA Paper #74-318, February 1974.
5. Miller, R. T., C. L. Long and S. Reitz: ASW Surface Ship of the 80's Study. Naval Engineers Journal, December 1972.
6. Babcock and Wilcox: CSNG Maritime Reactor, Phase III Midterm Report, Prepared for U.S. Maritime Administration, April 1971.
7. RADM Van Orden, M. D.: Opening Address at the ONR Workshop on Lightweight Nuclear Power Plants held October 22-25, 1974, Institute for Defense Analysis, Arlington, Virginia.
8. DeBiasi, V., and I. W. Sawyer: Worldwide Status of the Marine Gas Turbine ASME Paper 70-GT-44, 1970.
9. Sawyer, J. W.: Gas Turbine Engineering Handbook, Second Edition.
10. Neumann, J.: Gas Turbines in Ships - The Installation Problem, ASME Report #74-GT-165, April 1974.
11. Keller, C.: Operating Experience and Design Features of Closed-Cycle Gas Turbine Power Plants. ASME Paper No. 56-GTP-15, March 1956.
12. Kuo, S. C.: Recent Development of Closed-Cycle Gas Turbines and Gas-Cooled Reactors in West Germany and Switzerland. UTRC Report R76-952556-2, October 1976.
13. Gas Turbine International: Gas Generators and Reliability - November to December 1976.
14. Conway, D. H.: The Marine Gas Turbine Reliability Data Program. Naval Engineers Journal, April 1976.

REFERENCES (Cont'd)

15. Chmielewski, R., K. Vepa, L. Cheng, J. Bowyer: Fault Analysis of a Gas Turbine. HTGR-ASME Paper #76 GT99, March 1976.
16. Lee, S. Y. and W. E. Young: Gas Turbine Hot-Stage Parts in Aggressive Atmosphere. ASME Paper #75-WA/CD-1. July 1975.
17. Knorr, R. H. and G. Jarvis: Maintenance of Industrial Gas Turbines. ASME Paper #75 GT93. March 1975.
18. Anon: 10,000 shp Closed-Cycle Gas Turbine for Marine Propulsion. Escher Wyss Report, 1955.
19. Rackley, R. A.: Marine Closed Gas Turbine and LNG Refrigeration System Study - Part I, Closed Gas Turbine Marine Power Systems, Marad Report No. MA-RD-920-75003. June 30, 1974.
20. UTC/PSD: HTGR Direct Cycle Turbomachinery Technology. Final Progress Report PSD-R-106, Prepared for General Atomic Company. September 1976.
21. Kuo, S. C.: A Conceptual Design Study of Closed-Cycle Gas Turbines for Fusion Power Generation. Proceedings of the 11th Intersociety Energy Conversion Engineering Conference, Lake Tahoe, Nevada. September 12-17, 1976.
22. Kuo, S. C.: Solar Farms Utilizing Low-Pressure Closed-Cycle Gas Turbines. Proceedings of the 9th IECEC. August 26-30, 1974, San Francisco, California.
23. Kuo, S. C.: Closed-Cycle Helium Gas Turbines for UWMAK-III Fusion Power Generation. UTRC Report R75-952094-2, Final Program Report under the University of Wisconsin Contract No. BA-460D91-3 for Electric Power Research Institute. November 1975.

TABLE 1

ADVANTAGES OF CLOSED-CYCLE GAS
TURBINE PROPULSION SYSTEMS

- Potentially higher thermal efficiency
- Excellent part-load performance
- Compact, lightweight, and large unit capacity
- Moderate maximum cycle pressure and temperature
- Simplicity of arrangement and reliable
- Fossil or nuclear heat source
- Potentially low capital cost
- Potentially lower maintenance costs

LWSPS Incentives

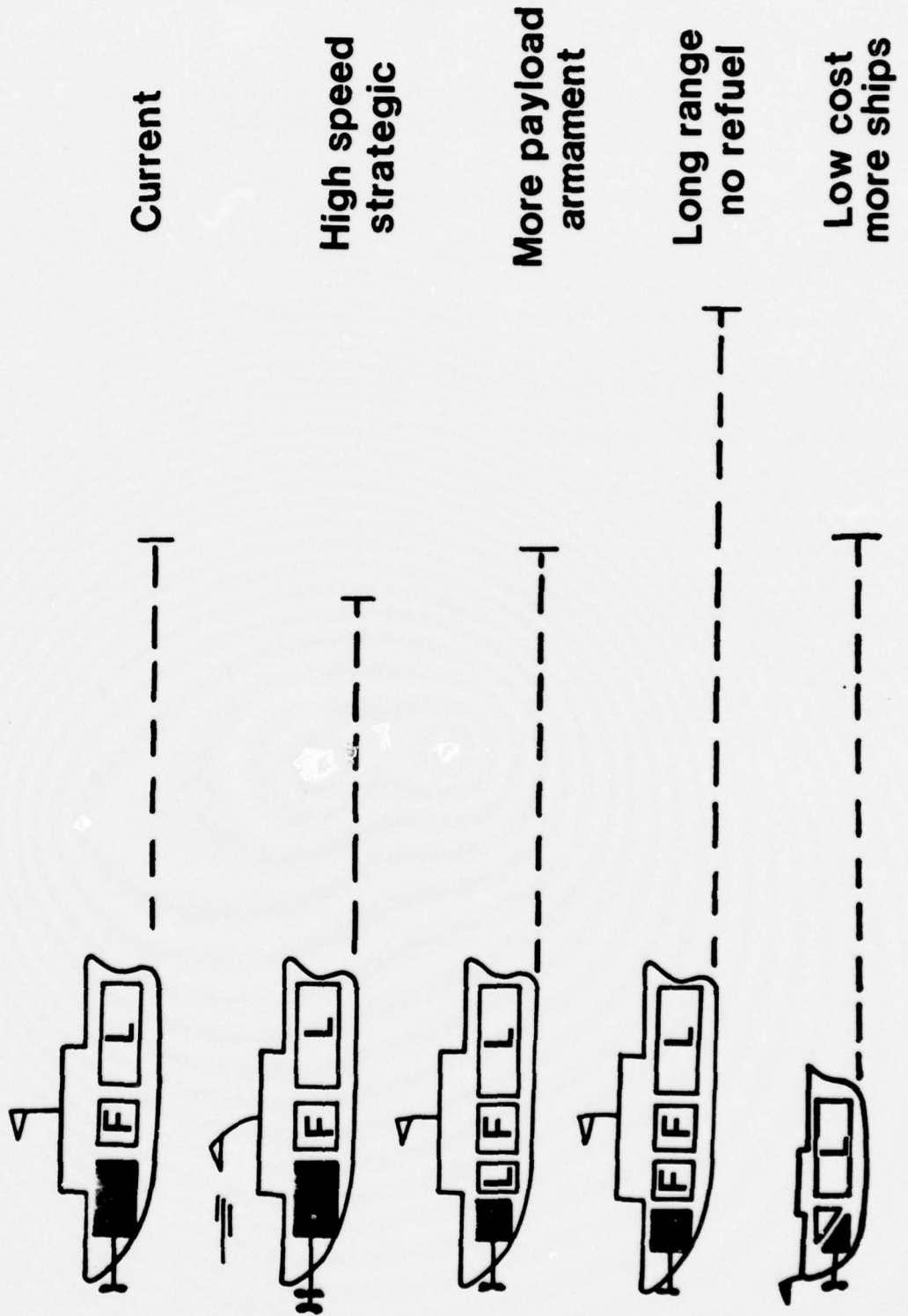

FIG. 1

SECTION I

CHARACTERIZATION OF PROPULSION SYSTEMS

Advanced Navy capital ships to be considered for evaluating the lightweight propulsion systems were selected and characterized, and the performance and weight characteristics for the propulsion system machinery components (transmission and thruster) have been estimated.

Selection and Characterization of Naval Ships

The selection and characterization of only a limited number of ship types was essential to this study in order to allow cost and time requirements to be manageable, and to effectively focus on the key issues. After a review of approximately twenty naval ship types currently operating in the United States and abroad, five ship types were selected to provide a reference frame for evaluating the candidate lightweight propulsion systems being studied. These types were selected according to the potential applications of lightweight propulsion systems in the 40,000 to 300,000 horsepower range (specified in the contract work statement), and the projected future needs for advanced capital ships in the U. S. Navy. These five ship types include: conventional and high-speed destroyers, high-performance ships, such as surface effect ships (SES), aircraft carriers, cruisers, and auxiliary ships. The specifications and performance requirements, i.e., displacement, maximum and cruise speeds, and typical range, for these ship types were based on a survey of existing ship data, a review of predicted mission requirements for future naval ships reported in the literature, and discussions held with Naval authorities and qualified experts.

Survey of Applicable Naval Ships

A survey was made of existing and proposed naval ship types to establish which could be categorized within the 40,000 to 300,000 horsepower range specified in this study. As a result, it was found that at least 20 types (see Table I-1) require installed power near or within this range. In this survey, published tabulations (Refs. I-1, I-2, and I-3) were consulted to estimate the installed power required for existing ships built throughout the world, while technical reports and periodicals (Refs. I-4 and I-5) were used to estimate the predicted power that will be installed in future ship types. These tabulations also provided estimates for maximum speed, endurance, and cruising speed. In Appendix A these data were used to estimate installed power for existing ships as a function of displacement, ship speed, and ship type. As a result, naval ship requirements were categorized into three basic regimes identified by their maximum speed: high-speed ships (50 to 80 knots maximum), conventional large ships (35 knots maximum), and auxiliary ships for cargo or fleet service (26 knots maximum).

Installed Power Requirements

The installed power required for the ship types in each of the three general categories just defined was estimated by using both actual survey data and correction factors applied to theoretical "clean hull" power requirements. These corrections were based on an estimated overall propulsive coefficient (OPC) and the additional auxiliary power (steam, electrical, cooling, catapult, hotel, etc.) required. These correction factors also varied with ship type (to account for variations in efficiency due to hull characteristics), thruster type and efficiency, number of thrusters, and service degradation. Overall propulsive efficiency was found to vary between 0.6 and 0.7 for conventional ships and between 0.4 and 0.6 for high-performance ships; auxiliary power was assumed to be 10 percent of the installed power for each ship investigated.

"Clean Hull" Power Predictions

The "clean hull" or towing power requirements for many of the ships noted in Table I-1 (hydrofoils, SES, high-speed displacement ships, and conventional displacement ships) were based on data from Ref. I-5; these data have been replotted in the form shown in Fig. I-1. The estimated clean hull power requirements were compared with the installed power requirements compiled during the survey mentioned earlier and are presented in Appendix A. The installed power was determined to be much larger than the clean hull predictions, since the latter do not include the effects of thruster efficiency, thruster/hull interaction, hull fouling (barnacles, etc.), auxiliary and hotel power requirements. In addition, it should be noted in Fig I-1 that these predictions are only for displacements up to 10,000 long tons and that each curve represents a ship designed for a particular maximum speed as indicated by that curve.

Estimation of Installed Power

In an effort to reconcile the clean hull power predictions with actual installed power, an estimate of the overall propulsive coefficient (OPC) must be made. During this study, the OPC was considered to be the ratio of clean hull power to actual engine output shaft power required (Refs. I-6 and I-7). Therefore, by dividing the clean hull power by the OPC and adding the appropriate auxiliary power requirement (typically 10 percent of propulsion power as noted), the power characteristics shown in Fig. I-1 can be extended appreciably. Naval authorities indicated that the OPC of current conventional U.S. Naval ships is in a range of 0.6 to 0.7 (Ref. I-8). Therefore, the power requirements for conventional ships form the narrow regimes shown in Fig. I-2. When these regimes are compared with the propulsion requirement data presented in Appendix A, it is seen that there is close correspondence of data for similar ships. This observation seems reasonable, since open-water thruster efficiency rarely exceeds 75 percent at speeds below 40 knots, although minimum values of OPC for actual ships could actually be much less than 0.6. For example,

hull fouling alone can increase propulsion power requirements by up to 30 percent in a matter of a few years, while hull/thruster interactions and the need to design reserve power into a given vessel can further increase installed power (Refs. I-5 and I-9). Thus, the clean hull predictions appear to be a good basis for estimating installed power requirements for conventional naval ships when proper OPC values are used.

The maximum overall propulsive coefficient for high-speed ships is most often near 0.6 (Ref. I-10), whereas minimum values may actually be close to 0.4. For example, waterjet thrusters alone often attain open-water efficiencies of only 50 to 60 percent. When the 0.4 to 0.6 range of OPC is used to correct the clean hull characteristics of the high-speed ships shown in Fig. I-1, the power characteristics shown in Fig. I-2 result.

Ship Type Selection

Since similar propulsion systems are applicable to a wide variety of ship types, it will not be necessary to review in detail all types of ships in the consideration of the candidate propulsion systems. Basically, the purpose of this survey was to identify those ships which will probably be in future service and which could benefit from lightweight propulsion systems. In addition, existing ship types which could significantly benefit from cost or fuel savings as a result of incorporating the new, lightweight propulsion systems were also considered. However, the specified installed power ratings between 40,000 and 300,000 shp would restrict the number of applicable ships to be considered. Five ship types (see Table I-2) chosen as being able to meet these criteria by utilizing different propulsion system alternatives are briefly discussed in the following paragraphs.

Conventional Destroyers

Destroyers with a maximum speed of 35 knots were selected as one of the ship types to be studied, since a high fraction of their total weight and performance level has traditionally been dependent on the propulsion system machinery characteristics of weight, volume, cost, efficiency, and performance (Refs. I-4 and I-5). The survey results illustrated in Fig. I-2 indicate that destroyers of 2000 to 9000 long tons displacement are within the power range considered in this study. Furthermore, it appears that based on consultations with qualified Naval experts and on open-literature sources, the U.S. Navy will continue to require destroyers for many more years (Refs. I-9, I-11, I-12, and I-13).

High-Performance Ships and High-Speed Destroyers

For years, predictions of future naval requirements have included numerous types of high-performance and high-speed ships for such missions as high-speed escort, antisubmarine warfare, and other similar applications (Refs. I-14, I-15, I-16, and I-17). Consultations with naval experts also indicated that high-speed

ships of the future could be selected from among the types such as surface effect ships (SES), hydrofoils, or wing assisted vehicles, or they simply could be likened to the more conventional-hull types operated at high speeds using the same power requirements as those of the exotic types (Refs. I-9 and I-18). The maximum speeds predicted for these ships fall within the range from 50 to 200 knots. Some of these predictions, as well as actual performance data for surface effect, hydrofoil, and conventional hull test craft have been included in the survey results presented in Appendix A for the speed range from 45 to 100 knots. Regardless of which final ship type and speed are established, the band of power requirements shown in Fig. I-2 indicates that the power requirements of these high-speed vessels will be large, and that until efficient, lightweight power plants are developed, the effectiveness of any high-performance ship will be limited in range, payload, cost, or other critical parameters. Therefore, high-speed ships were considered excellent candidates for utilizing the conceptual lightweight propulsion systems. For subsequent study in this program, two specific types of high-speed ships were considered. They were designated as "High-Performance Ships" (HPS) and "High-Speed (or 50 knot) Destroyers" (HSD).

The characteristics of a HPS were assumed to be similar to those predicted for future large SES vehicles in the 2000 to 5000 long-ton displacement class. These characteristics allow for lift power and drag relationships which differ from standard hull forms and which could affect propulsion system attractiveness. In addition, the high power levels required also apply to slightly slower hydrofoil vessels of similar displacement as mentioned earlier. Thus, the expression "High Performance Ship" refers to a class of SES, hydrofoil, and other novel-hulled vehicles on the same general power and performance range.

The HSD represents a class of future destroyers which would be capable of attaining maximum speeds of up to 50 knots. This ship most likely would use standard ship building equipment, procedures, and (destroyer) hull designs while incorporating increased power to achieve higher speeds. This concept could minimize the development funds required if the vessels were of a size similar to that of current destroyers (FFG-7 and DD963) in the 3000 to 7000 long-ton displacement class. The power-displacement envelope for both High-Speed Destroyers and High-Performance Ships is shown in Fig. I-2.

Cruisers and Aircraft Carriers

The fate of future construction for cruisers and aircraft carriers is unclear due to mission and/or cost limitations (Refs. I-19 and I-20). However, these classes of ships do require installed power within the range considered in this study, although restrictions on power system weight and volume are not as severe as in destroyers and high-performance ships (Refs. I-5 and I-21). The displacements of cruisers were assumed to range from 9000 to 25,000 long tons while aircraft carrier displacement was considered from 50,000 to 100,000 long tons. Based on

recent naval decisions, it appears that only ships of these types with displacements near the lower to middle portion of these ranges have a good probability of being constructed as evidenced by recent launchings of aircraft carriers of the Tarawa Class, and proposals for scaled-down Nimitz-type vessels and 15,000 long ton cruisers.

Auxiliary Ships

The auxiliary class of ships have been included in this study as being representative of the many varied types of noncombat support ships which the Navy utilizes (Refs. I-22 and I-23). Many of these present ships are aging, and their replacement by new vessels during the next 20 years would be at a time when new propulsion systems might be available. Furthermore, since the overall propulsion system operating requirements for these ships differ from those of combat ships, the optimum propulsion systems for these auxiliary ships could also be different. The displacement of the auxiliary ship type will be limited to the range of 30,000 to 40,000 long tons since consultation with ONR personnel indicated that this is the most likely future construction size.

Characteristics of Selected Ships

Further clarification of the characteristics of the chosen ship types must be based on consideration of such factors as speed, range, endurance, displacement, and reliability.

Maximum speed for the chosen ship types was selected by examining published literature and considering naval expert recommendations (Refs. I-9, I-11 and I-14); the results are presented in Table I-2. The cruise speed for a conventional-type ship is defined by the Navy to be 20 knots, although for high-performance ships, the cruise speed that produces the maximum range is often higher than 20 knots. For example, Refs. I-24, I-25, and I-26 indicate that the drag force for a 2000-4000 long-ton SES passes through a significant bucket in the speed-drag plot at speeds around 30 to 40 knots, while maximum range has been predicted to occur at speeds as high as 60 to 80 knots. During Part I study, a HPS cruise speed of 30 knots was selected, since this speed would still allow HPS vessels to cruise with a fleet as an escort.

Typical endurance and range values shown in Table I-2 are derived from the same sources as were those from the survey presented in Appendix A, and these are believed to be representative of values for existing ships and desired values for future ship types (Refs. I-1, I-5, and I-27). These ranges are based on continuous operation at cruise speed, although it should be realized that slightly better ranges often can be attained at speeds different from the cruise speed.

Because of the necessity to consider vulnerability and redundancy, it was assumed that at least two completely separate engine rooms and propulsion systems would be installed in combat vessels unless feasibility, cost, and/or the reliability of one system overrule this consideration (Ref. I-28). In small destroyers (similar to the FFG-7) where a small auxiliary return-to-port engine may be sufficient, single engines may be acceptable (Refs. I-29 and I-30). In auxiliary ships, a single propulsion system is also considered adequate. However, in the high-performance surface effect ships, allowance for separate lift power is often necessary.

Actual overall operational power, speed, and fuel requirements have a significant effect on the attractiveness of a propulsion system. As noted in Appendix A, the operational requirements and methods of propulsion system adaptation (for example, shutting down a number of the engines or turbines as power is reduced) can vary greatly, depending on the ship type chosen. These unique considerations, as well as those relating to the amount of time spent at each of several speed levels during the operation of a typical ship (its duty cycle) are considered in subsequent sections.

Typical Duty Cycle Requirements

In estimating the long-time fuel consumption, each of the ship types selected can be considered to operate according to specific duty cycles which specify the time (in percent) underway at each speed level, from which the various power levels required can be identified. This power-time relationship can be combined with the fuel consumption characteristics of the propulsion system(s) to determine the total fuel consumption for a given endurance.

Duty Cycle Speed/Time Relationships

The duty cycle (speed-time distributions) established for each ship type represents typical long-term average ship utilization rather than a specific mission requirement. Accordingly, the amount of fuel calculated to be used by the ship over a period of a given number of hours "endurance", when operated according to the duty cycle, is more representative of actual fuel requirements than would be a calculation made for specific mission requirements which may be representative of only a small percentage of the operational life of the ship.

The duty cycles which were used in this study are presented in Figs. I-3 and I-4. These relationships were derived from unclassified speed-time distribution surveys for existing ships (Ref. I-31) and for estimates of future ship types (Ref. I-32). Data from these references were modified by expanding the original one- or two-knot speed increments to ten-knot increments in the case of high-performance ships, and to five-knot increments for all other ship types. The resulting relationships still exhibit sufficient detail to allow representative fuel use estimates to be calculated when integrated with the power requirements and specific fuel consumption (sfc) characteristics, the latter of which will be presented in a subsequent section.

Estimated Power/Speed Relationships

The total installed power requirements identified and presented in Fig. I-2 define only the maximum power required for a given ship type. However, it is clear from the duty cycle relationships just discussed that a considerable portion of ship operation is spent at speeds less than those requiring maximum power. Since power increases exponentially with speed, the power required at reduced speeds will be significantly less than that at maximum speed. Thus, the duty cycle operation of a given ship should be considered prior to the installation of any of the many possible propulsion system arrangements.

Based on information obtained from Refs. I-5, I-10, and I-24, and from discussions with experts, it was possible to derive the power-speed relationships presented in Fig. I-5 for the different ship types. The data in this figure include thruster efficiency allowances which vary with speed as discussed in a

following section. In Fig. I-5 it can be seen that the characteristic shape of the curves is similar for all displacement hull vehicles. Those variations which do occur among these vessels are primarily due to the differing speeds at which the wave drag force "humps", predicted by the Froude number ($F = V/\sqrt{gL}$), occur based on the relationship of speed and ship length. However, for HPS vessels a somewhat different relationship exists.

The typical power-speed relationship shown in Fig. I-5 for the HPS is based on the SES. In addition, lift power is included as part of the total power required at each velocity level. Although, the lift power requirements are somewhat uncertain for the large SES vehicles at present, discussions with qualified experts and survey of the literature led to the lift power relationship presented in Fig. I-6 which should be adequate for the present analysis.

Thrustor Characteristics

Due to the large number of designs associated with the ship types selected, the thrustor types required for these ships are equally as diverse. Many current and proposed thrustor types, including fixed-pitch (FP) propellers, controllable-reversible-pitch (CRP) propellers, supercavitating propellers, water jets, ducted propellers, counter-rotating propellers, and pump jets, were reviewed. Since only the first four of these appeared to meet performance requirements over all of the operating regimes of the ships selected, they were selected for the propulsion systems study.

For the purposes of this present study, a literature survey was undertaken to determine typical shaft speed variations with thrustor power and vessel speed. These results were then used to determine diameter and weight at near maximum efficiency operation. Variations of operating efficiency were taken into consideration when operating speeds were other than those at the design point.

Thrustor Type Selection

The variety of thrustors, which convert the power of the prime mover into thrust and which were considered for the selected ship types are summarized in Table I-3. Current and proposed thrustor types were reviewed, and conventional, single-screw, nonducted, marine propellers were judged as being appropriate for continued use into the 1990's on all classes of conventional vessels as well as on high-speed ships. For appropriate speed regimes, both subcavitating and supercavitating FP and CRP propellers were considered. In addition, water jets are included as possible propulsors for high-performance ships. Subcavitating propellers operate very well for speeds below about 40-knots, and thus they were selected for the 26- and 35-knot ships; whereas, at speeds between 50 knots and 80 knots, supercavitating propellers and/or water jets were considered.

Other advanced concepts in service or under development include ducted propellers; dual, counter-rotating propellers; pump-jets; and propellers with various venting concepts to improve circulation to either avoid cavitation or to maintain supercavitation. Each of these advanced concepts aims at improved flow characteristics and propeller efficiency. However, relative to the more conventional thrusters, these advanced designs are generally heavier and less reliable; and they have yet to be proven in naval service. Furthermore, available performance and weight estimates are less reliable than those estimates for current designs, therefore, they were not considered in the present study.

The CRP propellers currently in service offer several attractive features. They solve the problem of quick reversing without necessitating a reversing gear in systems using unidirectional prime movers, e.g., gas turbines, and they allow the engine to be trimmed to operate at its optimum speed for best fuel consumption. However, relative to fixed-pitch propellers, the CRP propeller is limited to lower maximum shaft horsepower loadings, is relatively heavy, and it is reported to be noisier. However, both CRP and FP propellers were included for study so that the influence of differences in the maximum horsepower limits, propeller performance, and system weight could be evaluated. Figure I-7 summarizes the applications considered for these selected thrusters in this study.

Selected Thruster Characteristics

The thruster parameters have a complex effect on the propulsion system characteristics as shown in Fig. I-8. This is exemplified by the fact that thruster input speed and power limitations affect the power transmission system design and its arrangement. Thruster efficiency at design point and all other operating conditions will establish power and fuel use characteristics which must be applied to the duty cycle. In addition, the design and type of thruster selected significantly influence both the size and weight of the total propulsion system. Furthermore, due to the high installed power levels being considered in this study, and the anticipated capacity limitation for each selected thruster type being considered for operation in the 1990 time frame, the number of arrangements possible for delivering the total propulsion power could be restricted in some ship applications.

For the subcavitating fixed-pitch propeller, 80,000 shp per propeller has already been achieved in naval operation. Subcavitating CRP propellers, with ratings as high as 40,000 shp, are presently in use and supercavitating propellers have demonstrated that they can absorb over 15,000 shp in both fixed and controllable pitch configurations. Waterjets with input power ratings of approximately 20,000 shp have also been operated.

After reviewing the capabilities of manufacturers and conducting discussions with naval and hydrodynamics experts, projections were made relating to the maximum propeller capacity for each of the candidate thruster types which can be produced

by these manufacturers by 1990. For fixed-pitch subcavitating and supercavitating propellers, 100,000 shp per shaft is expected to be the upper limit by that time, while for CRP propellers, the maximum limit will probably be extended to 60,000 shp in both cavitating and supercavitating applications. Waterjets will be limited to a maximum of 50,000 shp. In order to obtain these increased maximum levels of power absorption, further engineering development will be required. Whereas, it is not expected that subcavitating propellers will require large expenditures of funds to improve their power handling capabilities, both supercavitating propellers and waterjets would require the expenditure of a considerable amount of development time as well as substantial funds to provide production capability at the power levels projected.

Marine propeller performance predictions and designs are typically based on performance charts derived from open-water "series test" data and predictions for ship interaction effects. This can be a time consuming process, the results of which remain unverified until actual service is achieved. Instead of designing the reference propellers in this manner for each ship selected for study (see Appendix B), a simplified method based on the shaft speed/power/ship velocity relationships shown in Fig. I-9 (and summarized in Table I-4) and the disk loading coefficient (C_T) - efficiency relationship of Fig. I-10 (derived from a data survey in Appendix B) was used. In this simplified approach, thruster rotational speed, derived from Fig. I-9 (or as explained in Appendix B) is combined with the C_T obtained from Fig. I-10 at a chosen efficiency (selected as close to maximum as is possible) to allow the diameter to be calculated by using the equation shown in Fig. I-10. (Typical results are shown in Appendix B.) This diameter was checked against typical maximum allowable propeller diameters such as those listed in Table I-5 (which were derived from considerations of ship type, thruster power level, thruster type and manufacturing limitations). The calculated diameter was then used as input to the graphed relationship in Fig. I-11 to determine thruster weight, both with and without controls, for subcavitating (manganese-bronze) and supercavitating (titanium) applications. This procedure should provide some assurance that the OPC values assumed earlier can be met.

Waterjet weights were estimated directly as a function of shaft horsepower as indicated in Fig. I-11. The relationship in Fig. I-11 is extrapolated from weight predictions for large power units (up to 40,000 shp) and data for smaller existing units.

Off-design performance for all thrusters was obtained from the selected propeller performance maps and reference literature without taking into consideration hull and wake interactions. However an estimate of the overall effect of operating at off-design point speeds as illustrated in Fig. I-12 (Ref. I-33) was used to adjust required power from corrected theoretical values. The variation in efficiency shown is included in the calculation of fuel requirements discussed in a later section of this report.

Transmission Type and Characteristics

Any normal speed reduction or any change in orientation required between the prime mover output shaft and thruster input shaft dictates that a transmission must be included as a major component of a propulsion system. Consequently, relationships had to be established to predict the weight, volume, and efficiency of the reduction gearbox and shafting. In order to establish these relationships, an initial survey was made of existing and projected worldwide capabilities of numerous transmission systems. These systems were screened in order to select only those which could provide a high level of confidence in future operation while still meeting the requirements for the ships, thrusters, and engine configurations being studied. In this manner, future performance projections of these components would not detract from the effect of the prime mover configurations on the overall systems.

Offset multiple reduction gearing and epicyclic and bevel gears were selected from a spectrum of possibilities (seen in Table I-6) that included hydromechanical, electrical, chain, and cable systems. While these other systems offered potential improvements in one or more areas of performance, cost, weight, or volume, all require further development efforts, and consequently they add to the risk in predicting future characteristics and were not included in the present Part I study.

For the types selected, a method of predicting transmission weights, volumes, and efficiencies was established based on the modification of methods presented in available literature. This method is basically a "building block" approach which allows the characteristics of complex arrangements of transmissions to be calculated in terms of the output horsepower/output speed ratio at a given level of gear loading for each building block.

Selection of Transmission Type

There are many available methods of transmitting power from the engine to the thruster based on the use of hydromechanical, electrical, chain or cable, and mechanical power transmissions, and many studies have presented the advantages and disadvantages of each type (c.f., Refs. I-34 and I-35). In selecting transmission systems for this present study, the ability to accurately predict the weight, volume, and efficiency characteristics which are expected to be available in the 1990 time period of interest, was a determining factor. Therefore, in Part I of this present study, only proven transmission systems for which a proven reference ship application could be cited were considered. This allowed the independent effect of the new propulsion engines being considered to be seen more readily. Mechanical transmissions utilizing gear technology projected to be available in production near 1990 assured that provision would be met.

Mechanical transmission or gearboxes can provide an almost limitless number of arrangements of gears and input and output shafts. However, only a few standard arrangements are normally used in ships. These arrangements include the concepts of single and multiple reduction-offset gear transmissions, epicyclic gearboxes, and bevel gear transmissions. An important consideration in gearbox design is the number of engine input shafts and thruster output shafts possible in a single unit since this affects the manner by which the power and operational limitations of engines and thrusters can be matched. In order to provide the flexibility needed to match the power plants and thrusters considered in this study, the following basic transmission configurations were considered: 1) single input-single output epicyclic; 2) single input-single output offset; 3) dual input-single output offset; 4) single input-dual output offset; and 5) bevel gears with a single-input and either single or dual-outputs. Reversing capability was assumed to be provided by offset and epicyclic gearboxes when CRP propellers were not used.

Single input-single output gearboxes having both single and multiple reduction stages are commonly used in commercial and military ships, and both offset and epicyclic gear arrangement concepts have been used to provide these arrangements. A dual major-input-shaft arrangement with a single output shaft is commonly used on naval ships and on some commercial vessels. This latter arrangement requires an offset, or an offset-plus-epicyclic transmission generally combined with multiple-stage gear reduction. In some ship transmission arrangements, more than two input shafts per offset gearbox have been used, but most often, the additional shafts are for small power inputs such as "cruise" diesel engines. Configurations incorporating multiple output shafts per gearbox have also found limited marine applications, although usually only one of these shafts is a major output with the others being used for lower power accessory drives (Ref. I-36). This arrangement requires offset gears or a combination offset plus epicyclic gears, and is required if engine power output exceeds maximum thruster capacity. Bevel gears are usually required on high-performance ships typified by the SES and hydrofoil types. This type of transmission has been considered for lift fans and remotely-located thrusters as well as for cross-connecting engines when a straight line drive can not be accommodated.

Figure I-13 summarizes the gearbox configurations selected for study and lists some of the major transmission characteristics (which will be considered in the next section). A code which has been used to identify the respective gearboxes in the parametric analysis is shown for each type. An "ε" identifies an epicyclic unit, a "β" identifies a bevel gearbox, and a combination of two numerals and a "θ" identifies offset gearboxes. Examples of the last type include 11θ for a single input-single output unit, 21θ for a dual input-single output unit, and 12θ for a single input-dual output unit.

It will be shown in a later section of this report that large engines can place a severe burden on mechanical transmissions, shafting, and thruster configuration. As a result, these arrangements might be more easily handled by electrical power transmission system. In the follow-on Part III study, the possible effects of electrical transmissions as a separate item will be evaluated once the more basic propulsion system parameters have been evaluated in the current Part I study.

Mechanical Transmission Characteristics

The efficiency, weight, and volume characteristics of the transmissions used in this study were estimated by using extrapolations of existing gearbox characteristics and empirically-derived prediction methods. Transmission efficiency has been assumed to be high with only one-half percent being lost through each gear mesh. However, weight and volume estimates are much more complex. Appendix C contains a description of the method used for establishing the weight and volume characteristics for each of the selected gearbox types considered in this analysis. Basically, the method described accounts for gear tooth loading limitations, design overload safety factors, and the shaft speeds at which the power is input and delivered. Casing weights, bearing design, and safety factors are assumed to remain close to the levels incorporated in past destroyer applications, since in these ships, weight saving measures have already been carefully balanced against unexpected distortion loads commonly occurring at sea.

The limitations discussed in Appendix C will require development testing and extensions of present technology prior to 1990. However, most of these limiting restrictions have been approached or exceeded in either past applications or in recent tests, and therefore, it seems reasonable to assume that they will be within the state of the art in 10 years. As a result, the transmission power delivery capabilities shown in Fig. I-13 are judged to be attainable by 1990.

During this study it was decided to simplify the gearbox configurations by eliminating combinations of offset and epicyclic gearboxes as well as those gearboxes with more than two gear reduction stages, since the potential complexity and lack of background information relative to these configurations could make potential improvements in their specific weights uncertain.

The critical relationships for transmission weight derived in Appendix C are shown in Fig. I-14 as a function of a "power/speed factor" ($Q/K_1 = HP_c (m+1)^3 / RPM_o K_1 m^2$). This factor is similar to the "Q factor" established by D. W. Dudley (Ref. I-37). It should be noted that the major difference between the present approach and that of Dudley is that the power term here (HP_c) is that transmitted by a single gear tooth in contact, while the total power transmitted (HP_t) can be up to 6 times larger (as often is the case in epicyclic gearboxes with low reduction ratios) as dictated by the number of teeth or "branches" sharing the power. In addition, Appendix C describes how the Dudley method was extended in this study to

provide estimates of weights for multiple-stage gearboxes. Through the use of these procedures, the thruster power-speed relationship from Fig. I-9 and typical gas turbine output shaft speed characteristics, the (minimum) gearbox weights shown in Fig. I-15 were estimated. Epicyclic gearboxes (with single- or double-stage gearsets) provide the lowest specific weight when a single input-single output shaft arrangement is used. However, when multiple engines are required, a dual-input, single-output offset gearbox can sometimes match or better the weight of an epicyclic gearbox transmitting the same total power.

The overall reduction ratio required also was found to have a substantial effect on gearbox specific weight. This overall ratio varies with power transmitted since it is dependent on the characteristic shaft speed required of thruster and engine as power is increased. Using typical shaft speed relationships for open-cycle and closed-cycle engines and thruster speeds from Fig. I-9, the specific weight trends shown in Fig. I-16 were developed for epicyclic gearboxes when installed in a 35-knot ship. Similar evaluations were performed in Section III (parametric analysis) for combinations of gearboxes, engines, thrusters, and shafts to determine minimum gearbox and/or propulsion system weight for selected ships applications.

Shaft Configurations and Weight Characteristics

In order to characterize more completely the overall system weight, the shaft weight must be considered since it potentially could be a large fraction of the system weight, particularly when thruster speed is low (100 to 300 rpm). Models for shaft installations which allow total shaft length to be established were based on past naval ship experience. This allowed parameters critical to the propulsion system evaluation to be studied without introducing specific naval architecture variances. Estimates for shaft weight per foot were found to be a function of the horsepower transmitted, the shaft speed, and a limit on shaft shear stress. All shafts were hollow with a ratio of inner-to-outer diameter of 0.65, and a maximum limit on shear stress of 12,000 psi was selected. Furthermore, a maximum of four primary shafter per ship were allowed. Figure I-17 presents the results of calculations for specific shaft weight (lb/shp) resulting from use of the model (see Appendix D) in conjunction with the thruster power-speed relationship from Fig. I-9.

The arrangement for the shafting had to be established for each ship type since shaft weight depended on the diameter and length of shafting required. The diameter was determined as a function of power delivery, rotational speed, stress, and inner bore diameter. Factors which increased the dynamic stress, such as unbalance, critical speed, and shaft length between bearings, were not specifically identified in this study. However, the level of stress chosen, in combination with the actual shaft system weights which comprise the basis for establishing the model made sufficient allowances for appropriate measures to minimize this problem.

The total length of shafting and weight of related support and bearings required depended on the positioning of engine and thruster as shown in Appendix D. The total length of shafting required on each ship was calculated from a model (again,

R77-952566-5

see Appendix D) which was based on data derived from a survey of existing and proposed Navy ships. This length was found to be dependent on both the number of shafts selected and the power carried per shaft. Included in this model are allowances for combat vulnerability, engine room size and placement, weight distribution, number of thrusters, thruster placement, lift fans, cross-connections, and water-tight bulkheads.

As a point of comparison, survey data revealed that current destroyers often require shaft lengths in excess of 100 feet per propeller; whereas, shafts on large aircraft carriers have exceeded 380 feet. The total length determined from the model then was used in conjunction with specific weight per foot of shaft to establish the total shaft weight and specific weight as shown in Fig. I-17.

REFERENCES FOR SECTION I

- I-1. Blackman, R. V. B. (ed.): Jane's Fighting Ships; McGraw Hill 1976, 1975, 1972, 1970, 1965.
- I-2. Morison, S. L., J. S. Rowe: The Ships and Aircraft of the U. S. Fleet; 1975.
- I-3. Janes Surface Skimmers; McGraw Hill 1976.
- I-4. Mandel, P.: Advanced Marine Vehicles/Propulsion; Paper presented at ARPA Technical Meeting on Advanced Propulsion Concepts; Oct. 20, 1975.
- I-5. Riddell, F. R.: Survey of Advanced Propulsion Systems for Surface Vehicles; Institute for Defense Analysis; Jan. 1975; Paper #P-1073 IDA Log # HQ 75-16706.
- I-6. Barnaby, K. C.: Basic Naval Architecture; John DeGraff Inc. 1960.
- I-7. Navpers: Principles of Naval Engineering; Bureau of Naval Personnel; NAVPERS 10788-B.
- I-8. Seng, R.: Personal discussion at ONR.
- I-9. Mandel, P.: Consultation at Massachusetts Institute of Technology.
- I-10. Barr, R. A., Etter, R. J.: Selection of Propulsion Systems for Hi-Speed Advanced Marine Vehicles; Marine Technology January 1975.
- I-11. Seng, R.: Consultations, ONR.
- I-12. Leopold, R.: Gas Turbines in the U. S. Navy Analysis of an Innovation and Its Future Prospects as Viewed by a Ship Designer; Nav. Eng. Journal, April 1975.
- I-13. Bertelson, P.: Consultations.
- I-14. Rainey, P. G.: Basic Ocean Vehicle Assessment; Nav. Eng. Journal, April 1976.
- I-15. Decker, J. L.: High Speed Marine Vehicles - A Design Outlook; Lecture given to Royal Aeronautical Society, Oct. 19, 1972.
- I-16. Sonenshein, N.: Toward the 50 Knot Navy; Astronautics; June 1970.
- I-17. Mandel, P.: A Comparative Evaluation of Novel Ship Types; The Soc. of Naval Architects and Marine Engineers, Spring Meeting Duluth, Minn. June 21-23, 1962.

REFERENCES FOR SECTION I (Continued)

- I-18. Mandel, P.: Introduction to "An Assessment of Competitive Water, Air, and Interface Vehicles"; M.I.T. Industrial Liaison Program, Aug. 2, 1975.
- I-19. Zummalt, E. R.: Small Economy Size; Undersea Technology, November 1971.
- I-20. Alden, J. D.: U. S. Navy No Longer Second to None; Marine Engineering/Log, June 15, 1975.
- I-21. Dawson, K. J., E. C. Tupper: Basic Ship Theory; American Elsevier Publishing Co., 1968.
- I-22. Johnson, R. P., H. P. Rumble: Weight Cost and Design Characteristics of Tankers and Dry Cargo Ships; Rand Corporation, April 1963, Memo #RM3318PR.
- I-23. McIntire, J. G., G. E. Hilland: Design of the A0177 Machinery Plant; Nav. Engs. Journal, Feb. 1976.
- I-24. Chaplin, J. B.: Amphibious Surface Effect Vehicle Technology - Past, Present, and Future; AIAA/SNAME Advanced Marine Vehicles Conference, San Diego, Feb. 25-27, 1974, UP 7401466 AIAA # 74-318.
- I-25. Trillo, R. L.: Marine Hovercraft Technology, U. S. Naval Institute for Leonard Hill, London, 1971.
- I-26. Mantle, P. J.: A Technical Summary of Air Cushion Craft Development; David W. Taylor Naval Ship Research and Development Center, Oct. 1975; NTIS AD A022583.
- I-27. Miller, R. T., C. L. Long, S. Reitz: ASW Surface Ship of the 80's Study; Nav. Eng. Journal Dec. 1972.
- I-28. Comstock, J. P. (ed.): Principles of Naval Architecture; The Society of Naval Architects and Marine Engineers, 1967.
- I-29. Kenyon, C. W.: A Design Concept to Provide Auxiliary Propulsion in Single Screw Ships; Nav. Eng. Journal, April 1976.
- I-30. Anon: Frigate Propulsion Systems - The Choices to be Made; Shipbuilding Periodical, 1974-1975.
- I-31. Navsec Speed-Time Distribution Figure No. 6435, Sept. 20, 1966.
- I-32. Woolen, E. B.: Ocean Control, Hovering Craft and Hydrofoil, Vol. 15, No. 12, Sept. 1976.
- I-33. vonSchertel, Baron Hanns: The Design and Application of Hydrofoils and Their Future Prospects -Trans. Inst. Marine Engineers, Vol. 86, Series A, Part 3, 1974.

R77-952566-5

REFERENCES FOR SECTION I (Continued)

- I-34. McCann, E. F. and C. J. Mole: Superconducting Electric Propulsion Systems for Advanced Ship Concepts, AIAA/SNAME/USN Advanced Marine Vehicles Meeting, Annapolis, Maryland, July 17-19, 1972.
- I-35. Pickert, H.: Applicability of Hydrodynamic Transmission to Ship Propulsion with Gas Turbines and CODAG Plants, ASME Paper No. 70-GT-85, May 24-28, 1970.
- I-36. Anon: Halborg to Build Danish Corvettes, Shipbuilding & Marine Engineering Intl., Jan/Feb 1976.
- I-37. Dudley, D. W.: Gear Handbook, McGraw-Hill, 1962.

TABLE I-1
SUMMARY OF SHIP TYPES CONSIDERED

<u>Ship Type</u>	<u>Displacement (Long Tons)</u>	<u>Installed Power (Thousands of shp)</u>
Destroyer - current	1,000 - 9,000	40,000 - 120,000
Destroyer - hi-speed	1,000 - 8,000	100,000 - 300,000
Hi performance ships	100 - 5,000	5,000 - 300,000
Cruisers	9,000 - 30,000	80,000 - 200,000
Aircraft carriers	40,000 - 100,000	180,000 - 300,000
Auxiliary ships	10,000 - 100,000	20,000 - 120,000
Amphibious warfare ships	10,000 - 50,000	10,000 - 40,000
Battleships	40,000 - 60,000	180,000 - 250,000
Hydrofoils	50 - 10,000	5,000 - 300,000
Patrol boats	50 - 2,000	5,000 - 40,000
Air cushion vehicles	10 - 2,000	5,000 - 100,000
Icebreakers	5,000 - 30,000	10,000 - 60,000
Seagoing tugs	1,000 - 5,000	
Tankers	20,000 - 500,000	10,000 - 100,000
Container Ships	10,000 - 100,000	20,000 - 200,000
LNG ships	20,000 - 100,000	10,000 - 40,000
Swath ships	100 - 10,000	10,000 - 200,000
Catamarans	2,000 - 6,000	20,000 - 250,000
Sea control ships	10,000 - 60,000	100,000 - 250,000
W. I. G. vehicles	100 - 2,000	10,000 - 250,000
Landing craft	100 - 2,000	
Command ships	15,000 - 30,000	100,000 - 150,000

TABLE I - 2

SELECTED SHIP TYPES AND CHARACTERISTICS

<u>Type Ship</u>	<u>Displacement</u> (Long Tons)	<u>Maximum</u> (hp)	<u>hp/Long Ton</u>	<u>Speed</u> (Knots)		<u>Typical Range</u> (N. Miles) @ <u>Cruise Speed</u>
				<u>Maximum</u>	<u>Cruise</u>	
Aircraft Carrier	50,000 → 100,000	240,000 to 300,000	4.8 → 3.0	35	20	15,000
Cruiser	9,000 → 25,000	110,000 to 180,000	12 → 7	35	20	10,000
Destroyer Current	3,000 → 9,000	50,000 to 110,000	17 → 12	35	20	8,000
High Speed	3,000 → 7,000	160,000 to 300,000	54 → 43	50	20	6,000
High Performance Ships (HPS)	2,000 → 4,000	180,000 to 300,000	90 → 70	80	30	4,000
Auxiliary	30,000 → 40,000	55,000 to 65,000	1.6 → 1.5	26	20	8,000

TABLE I-3
THRUSTORS CONSIDERED

Marine Propellors

Conventional

- Single screw per shaft
- Unducted
- Subcavitating
- Supercavitating
 - fully submerged
 - full cavitation
- Fixed pitch (FP)
- Controllable pitch (CP)
- Controllable reversible pitch (CRP)

Advanced

- Dual counter-rotating
- Ducted
- Partially submerged super-cavitating
- Partial cavitation
- Supercavitating CRP

Water Jets

Pump Jets

TABLE I-4
SELECTED SHAFT RPM

Thruster type	Subcavitating FP & CRP		Supercavitating FP & CRP	Water Jet
Shaft HP \ Ship speed (knots)	26	35	50-80	
20,000	160 RPM	320 RPM		1600
30,000	140	260		1250
40,000	120	230	980	980
50,000	110	200	800	800
60,000	105	180	700	
80,000	100 ⁽¹⁾	160 ⁽¹⁾	580 ⁽¹⁾	
100,000	98 ⁽¹⁾	150 ⁽¹⁾	480 ⁽¹⁾	

(1) Fixed pitch only

TABLE I-5

MAXIMUM ALLOWABLE PROPELLER DIAMETERS

<u>Ship Type</u>	<u>Displacement (Long Tons)</u>	<u>Maximum Propeller Diameter (ft.)</u>
Destroyer	3,000	15
Destroyer	9,000	19
Cruiser	9,000	19
Cruiser	25,000	20
Aircraft Carrier	50,000	20
Aircraft Carrier	100,000	25
Auxiliary Ship	30,000	20
Auxiliary Ship	40,000	25
HSD (supercav)	3,000	8
HSD (supercav)	6,000	10
HPS (supercav)	2,000	7
HPS (supercav)	5,000	9

TABLE I-6
GEARBOX TYPES AND CHARACTERISTICS

<u>Type Gearbox</u>	<u>Critical Characteristics Identified</u>	<u>Ship Installation to be Considered</u>
Offset	<p>Allows varied arrangements Weight low for high hp/rpm, high reduction ratio, multiple shafts High reliability Known technology and improvements possible Max output = 150,000 hp by 1990</p>	All types (Destroyer, H P S , Cruiser, Carrier, Auxiliary)
Epicyclic	<p>Low specific volume Higher complexity Minimal experience Max output = 80-100,000 hp by 1990</p>	Destroyer, H P S , Cruiser, Auxiliary
Bevel	<p>Allows remote engine location High maintenance Max output = 60,000 hp by 1990</p>	Destroyer, H P S
Hydromechanical, Electrical, Chain, Other	<p>High specific weight Costly Requires much development effort</p>	None

TABLE I-7

METHODOLOGY FOR ESTIMATING GEARBOX WEIGHT

Established analytical models

Updated Dudley's Q factor method, $W \propto \left(\frac{Q}{K}\right)^X$

$$Q = [\text{shp/rpm}] [(m+1)^3/m]$$

Generalized to include complex arrangements

Selected gear tooth loading limits

K factor $\left\{ \begin{array}{l} 300 \text{ for conventional ships} \\ 400 \text{ for high-speed ships} \\ 500 \text{ for lift fan drive} \end{array} \right.$

Tooth loading limited by 3500 lb /inch

Estimated compatible gearbox weight

THEORETICAL CLEAN HULL POWER REQUIREMENTS

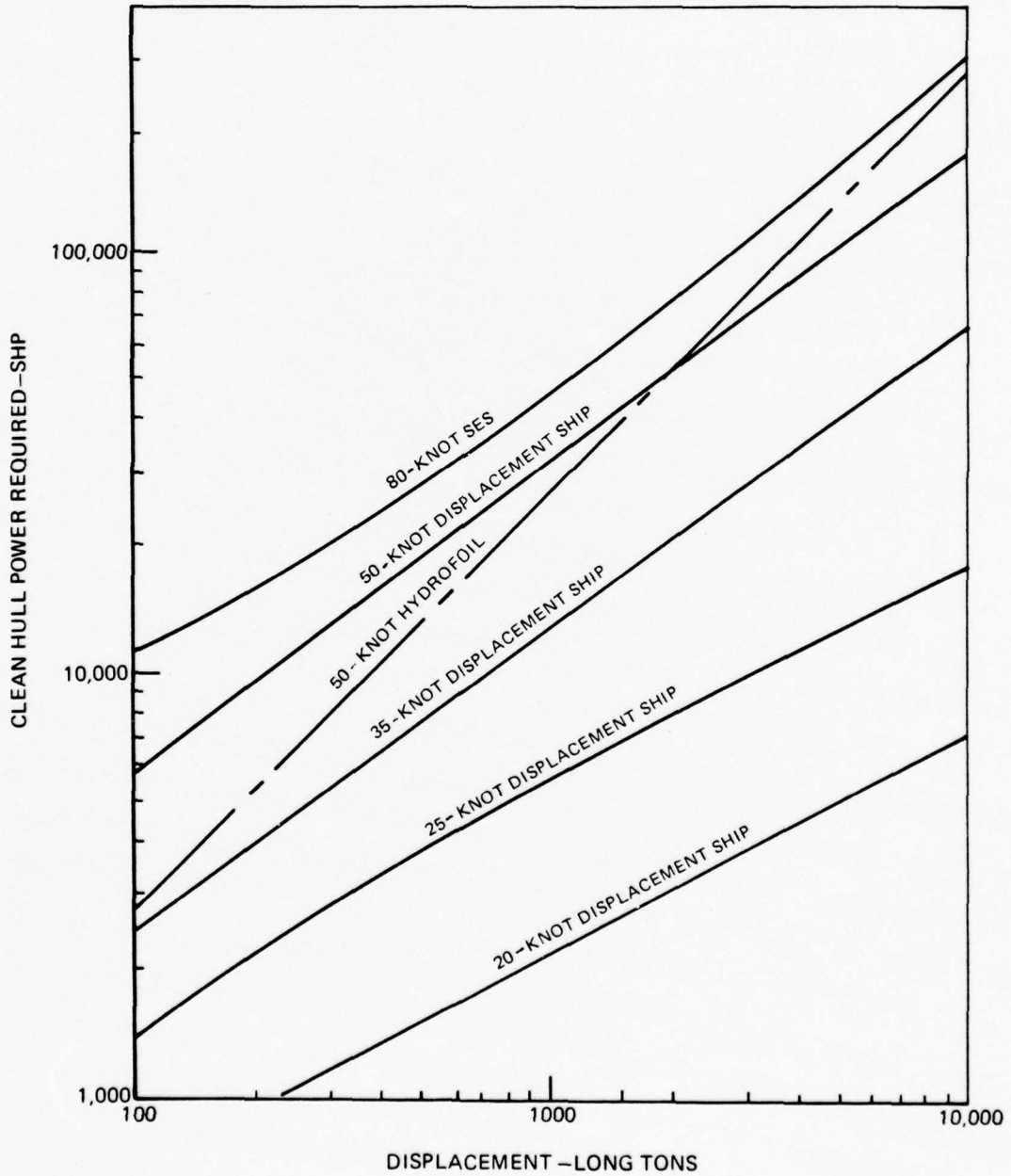

CHARACTERIZATION OF SELECTED NAVAL SHIPS

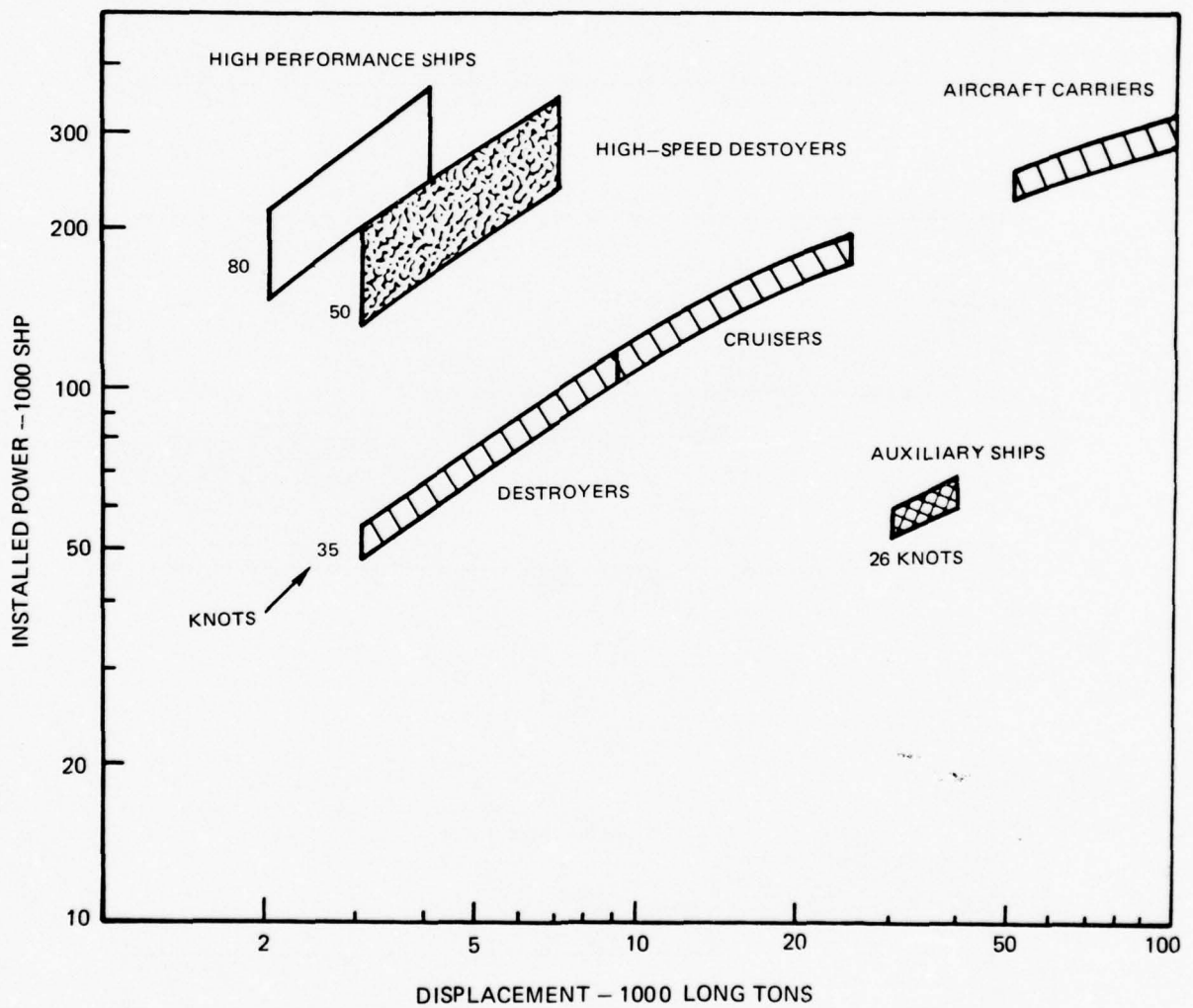

SPEED-TIME DISTRIBUTION MODELS FOR NAVAL SHIPS

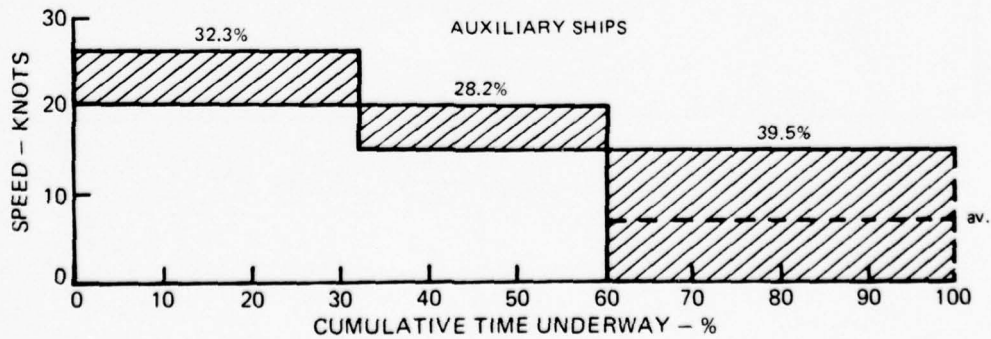
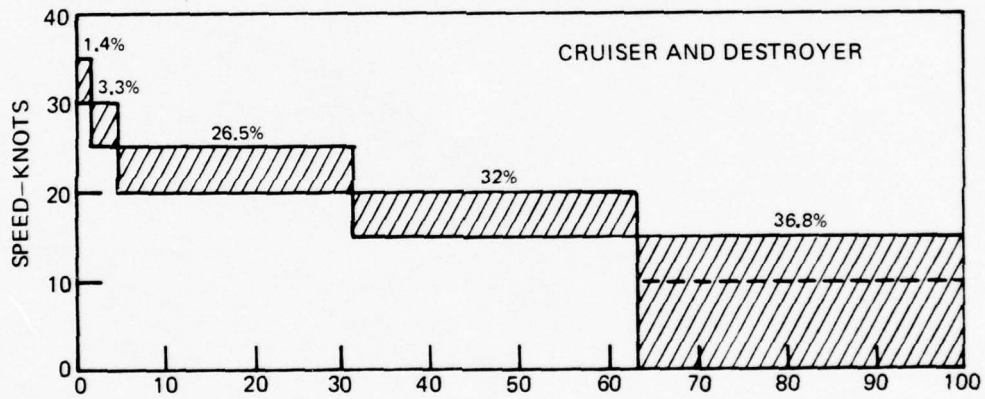
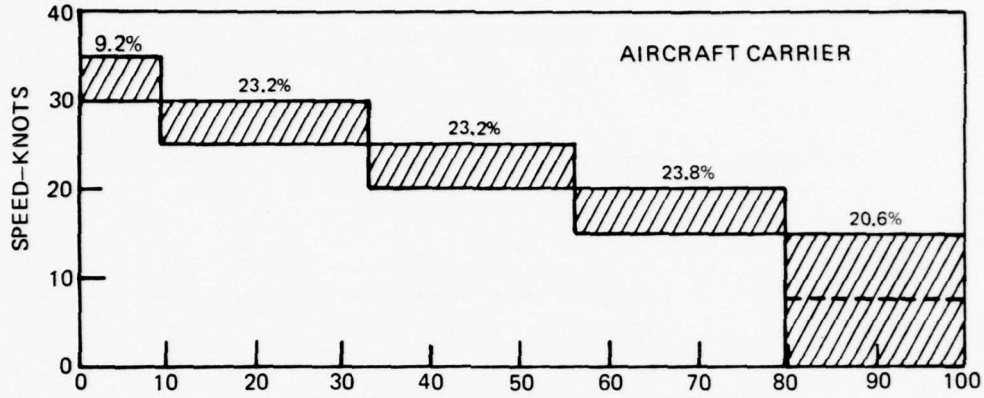

SPEED-TIME DISTRIBUTION MODELS FOR NAVAL SHIPS

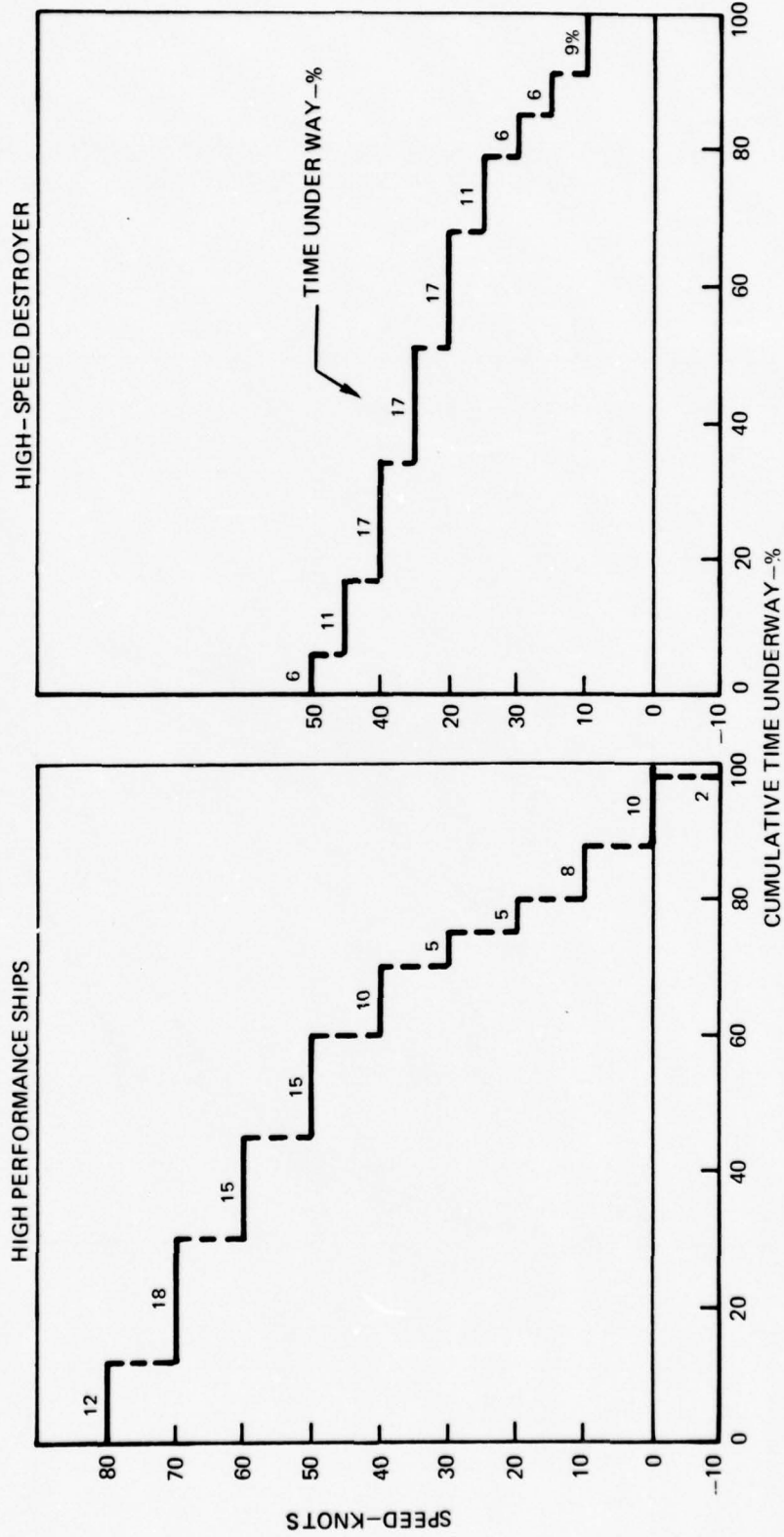

TYPICAL POWER-SPEED RELATIONS FOR SELECTED NAVAL SHIP PROPULSION SYSTEMS

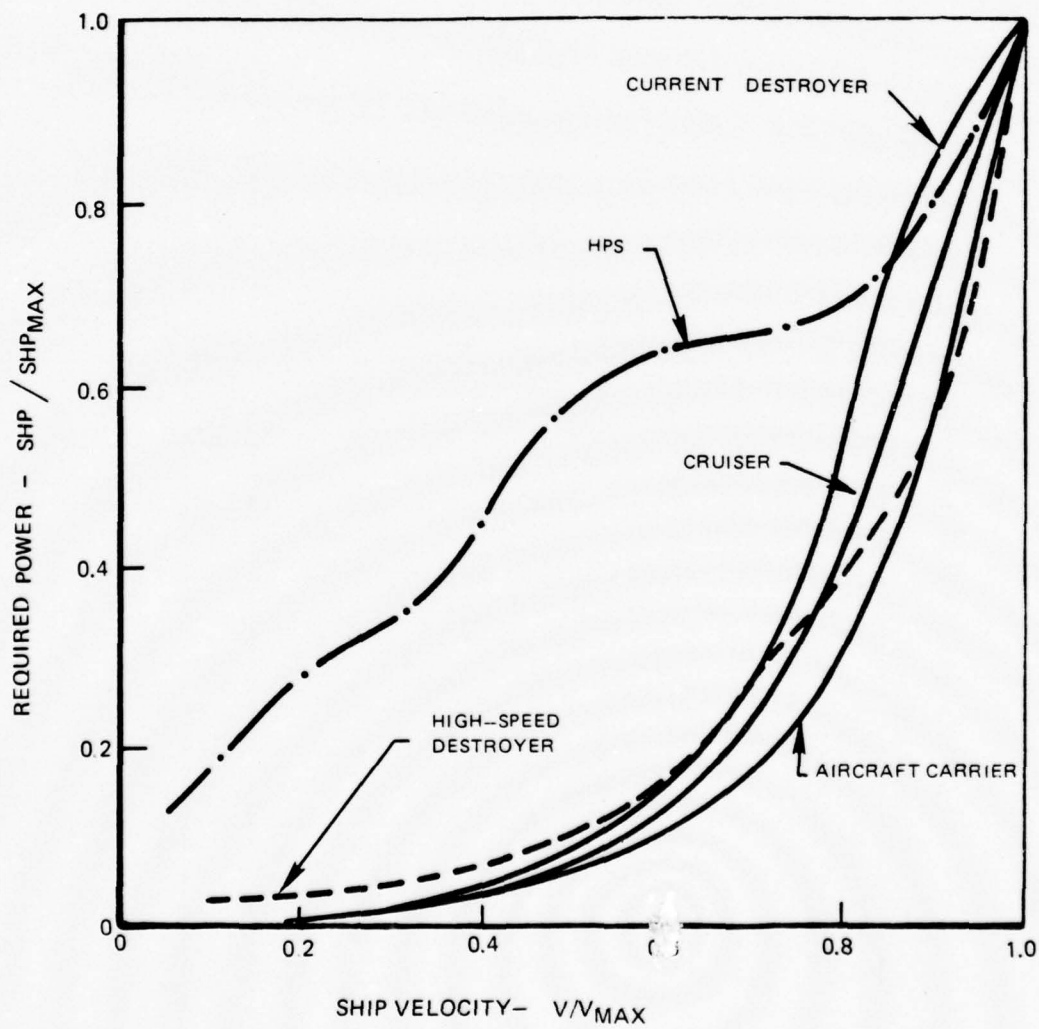

SES LIFT POWER REQUIREMENTS

2000 TO 4000 L.T. DISPLACEMENT

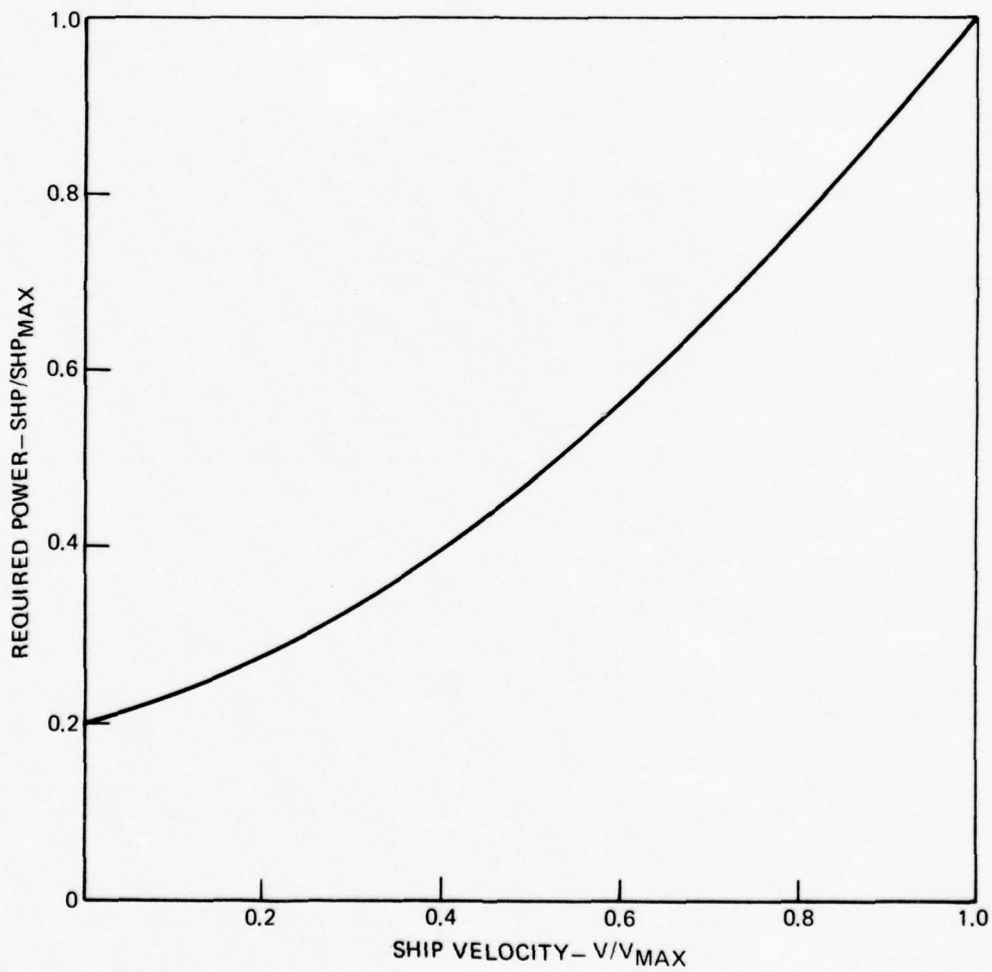

SELECTED REPRESENTATIVE THRUSTORS

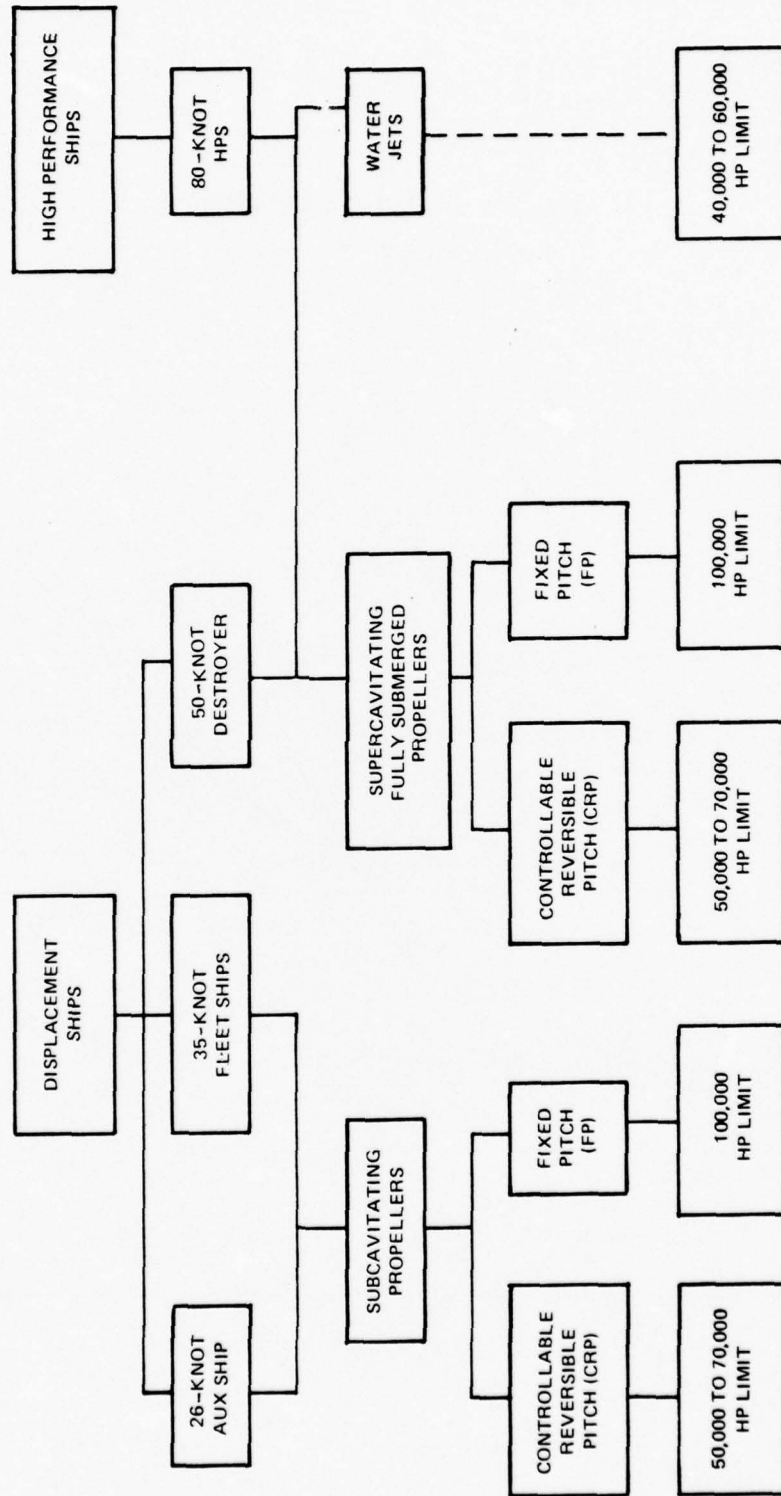

THRUSTOR INPUT DATA AND IMPACT

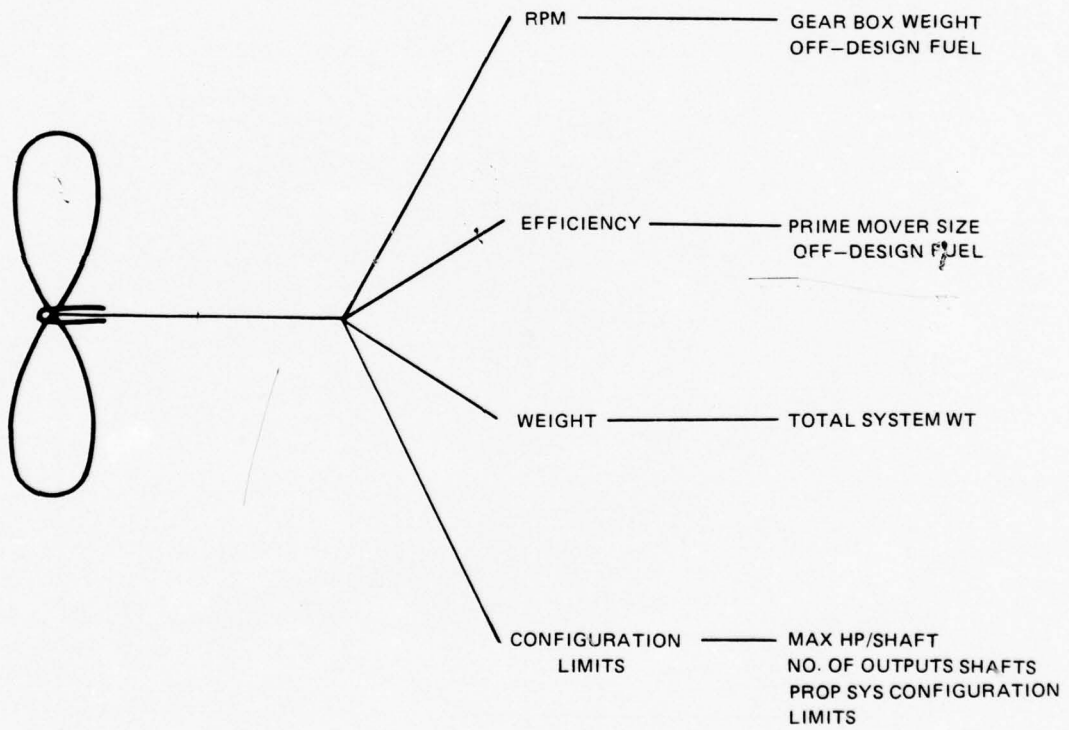

SELECTED THRUSTOR VARIATION WITH POWER

- ▼ FIXED PITCH
- ◇ CONTROLLABLE PITCH
- WATER JET
- THEORETICAL
- η_0 = PROPELLER EFFICIENCY

FILLED SYMBOLS : SUPERCAVITATING

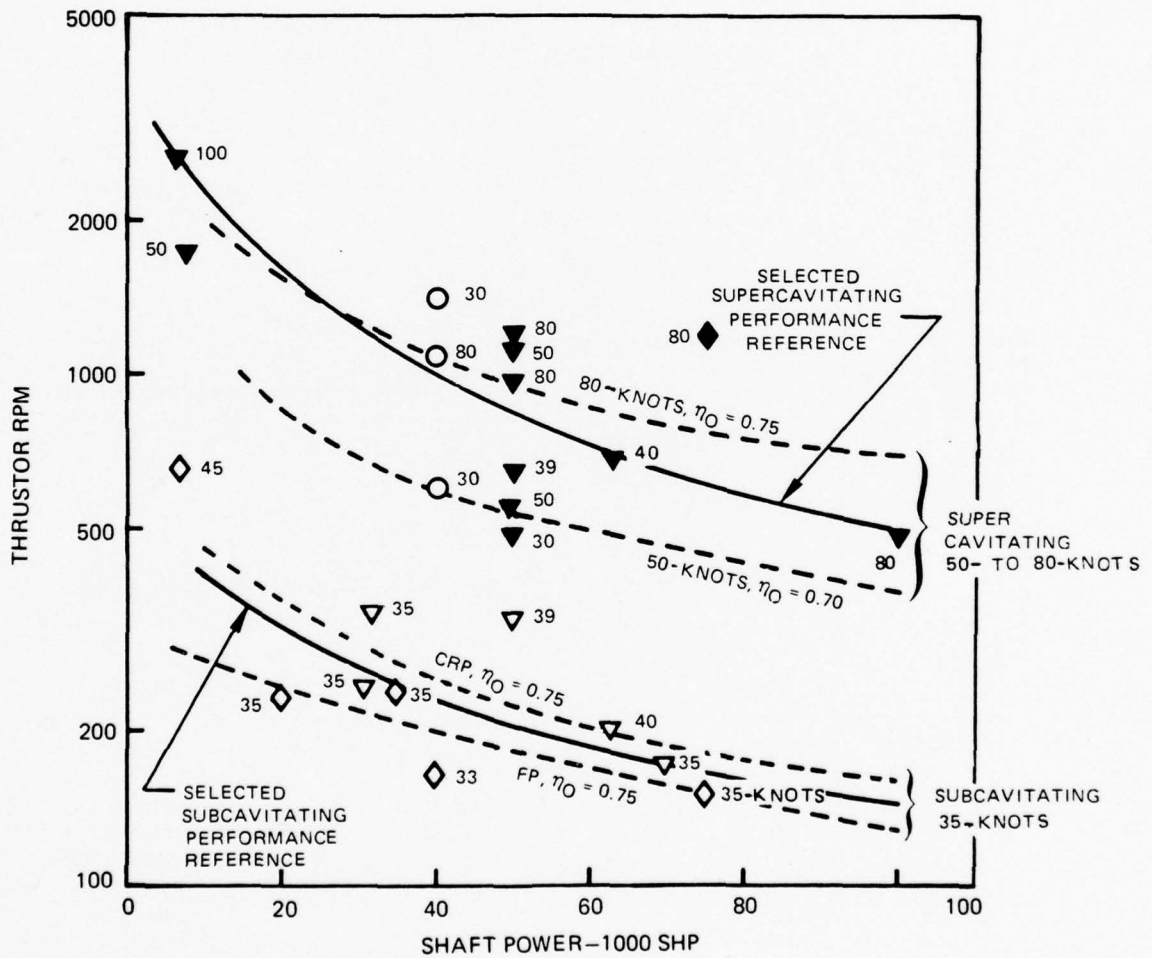

SELECTED THRUSTOR PERFORMANCE CHARACTERISTICS

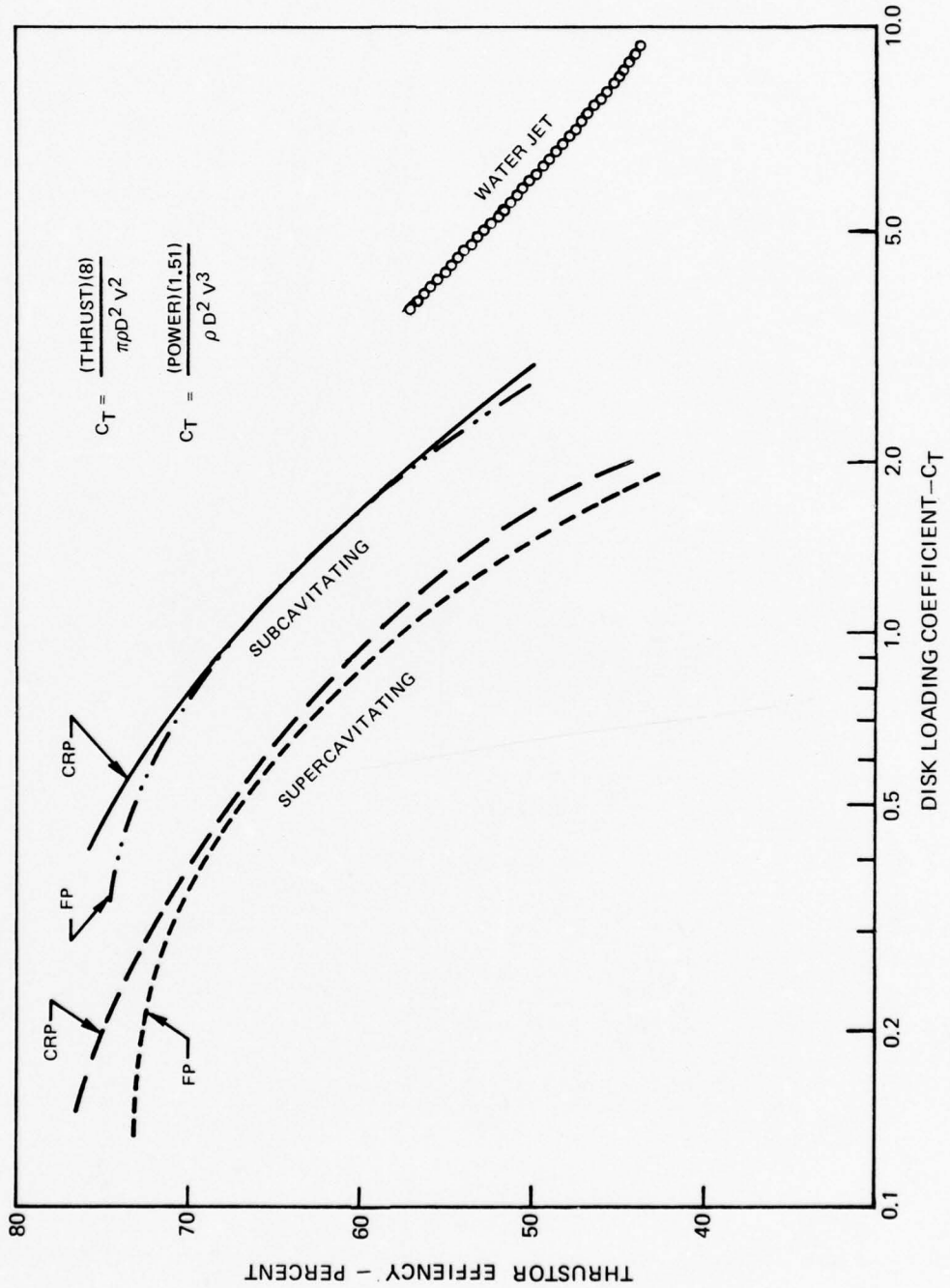

ESTIMATED THRUSTOR WEIGHTS

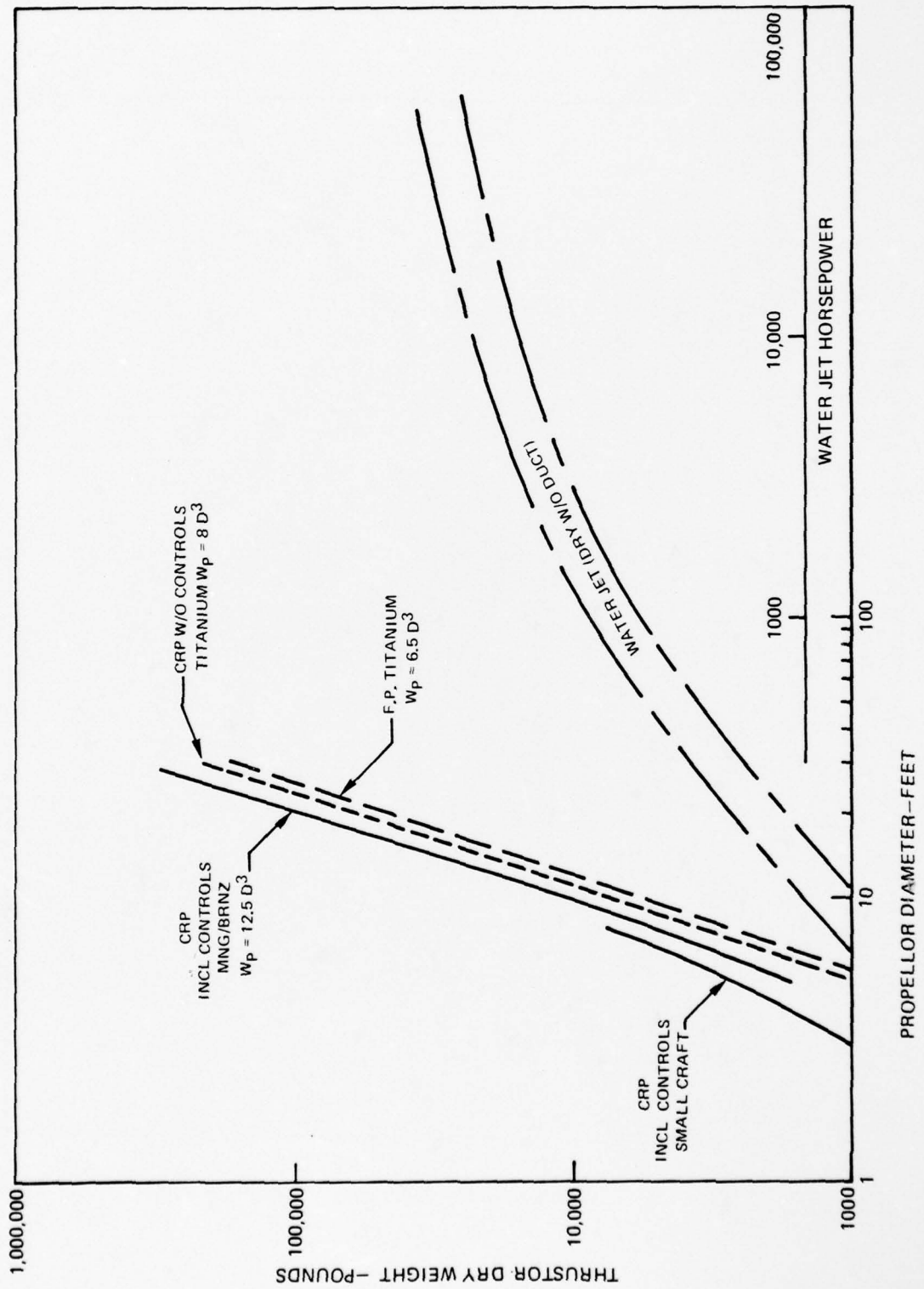

TYPICAL VARIATION OF THRUSTOR EFFICIENCY WITH SHIP SPEED

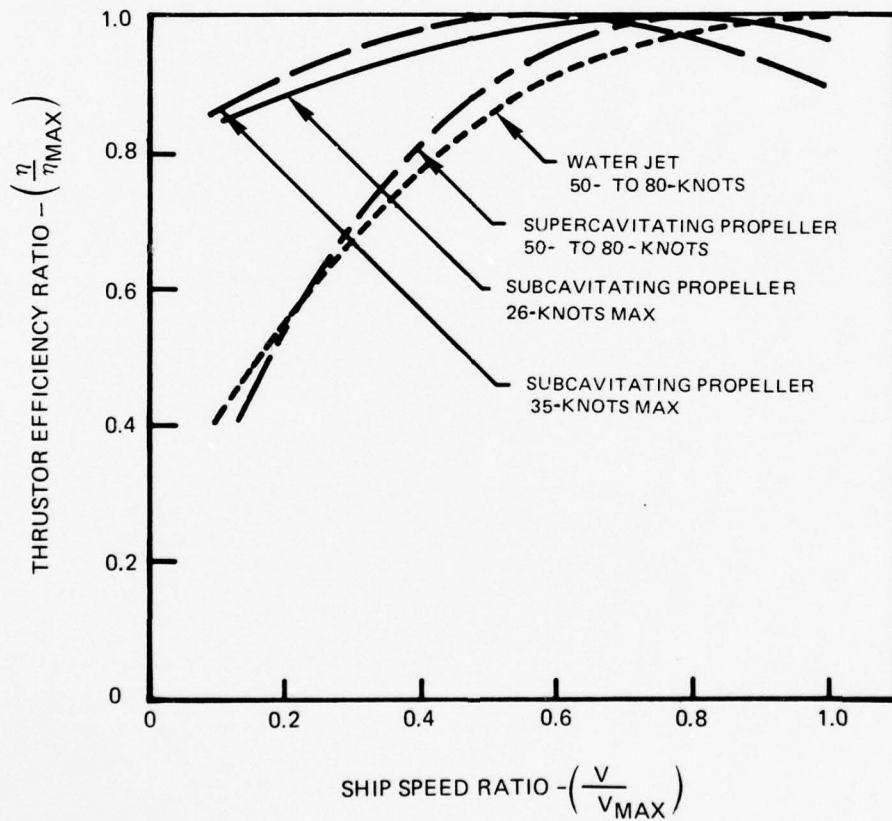

SELECTED GEARBOX CHARACTERISTICS

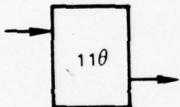
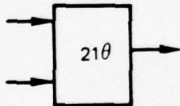
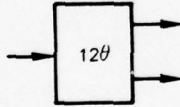
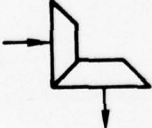
TYPE	MAXIMUM POWER SHP	ADVANTAGES
EPICYCLIC 	100,000	1. LOWEST WEIGHT AT LOW REDUCTION RATIOS 2. SIMPLER, LOWER WEIGHT REVERSING CAPABILITY 3. LOWEST VOLUME
OFFSET 	100,000	1. POSSIBLE LOWER COSTS IN SOME APPLICATIONS
	150,000	1. UTILIZES EXISTING OR SMALLER ENGINES 2. BETTER OCGT CRUISE SFC
	150,000	1. UTILIZES LARGER ENGINES 2. LOWERS PROPELLOR SHAFT SPECIFIC WEIGHT 3. LOWERS REDUCTION RATIO REQUIRED
BEVEL "β" 	60,000	1. ALLOWS UNUSUAL ENGINE LOCATION AS IN H.P.S. 2. ONLY USED FOR HIGH SPEED SHAFTS

ADJUSTED THEORETICAL RELATIONSHIPS CHOSEN FOR GEARBOX WEIGHT ESTIMATION

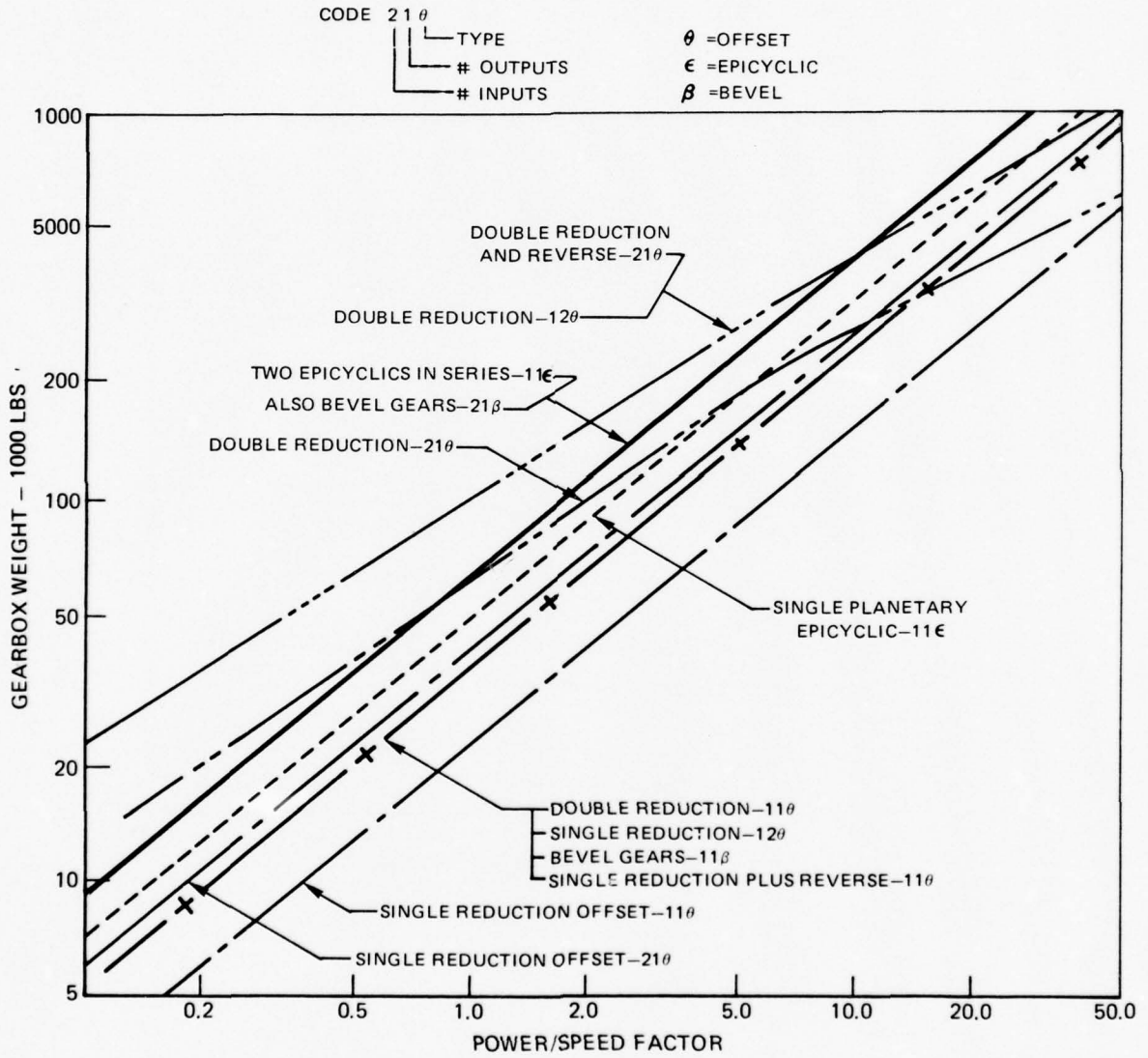

$$Q/K_1 = \left(\frac{HP_c(m+1)^3}{RPM_o K, m^2} \right)$$

ESTIMATED MINIMUM GEARBOX SPECIFIC WEIGHT

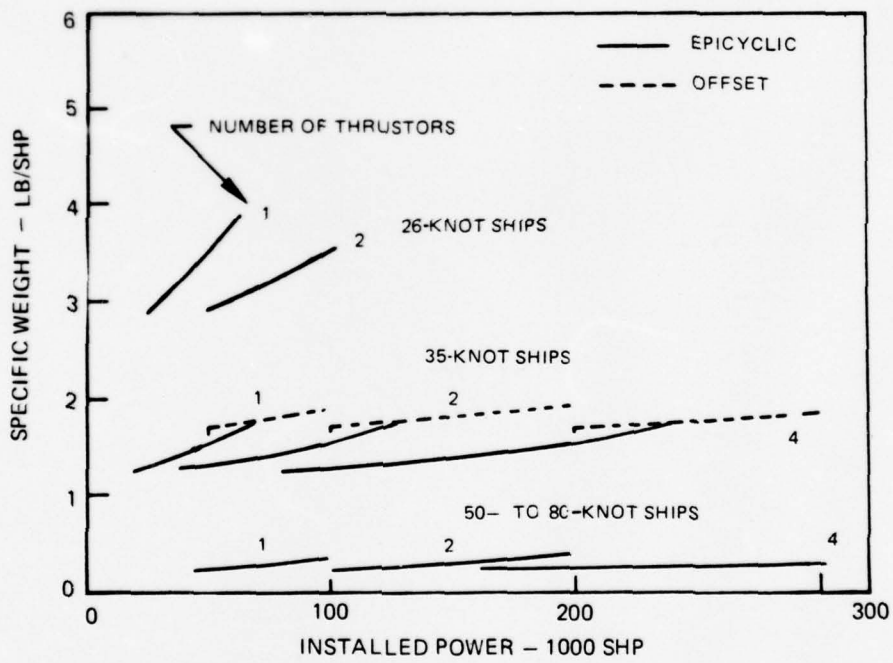

EFFECT OF REDUCTION RATIO ON GEARBOX WEIGHT

EPICYCLIC GEARBOX, K = 300
35-KNOT SHIP

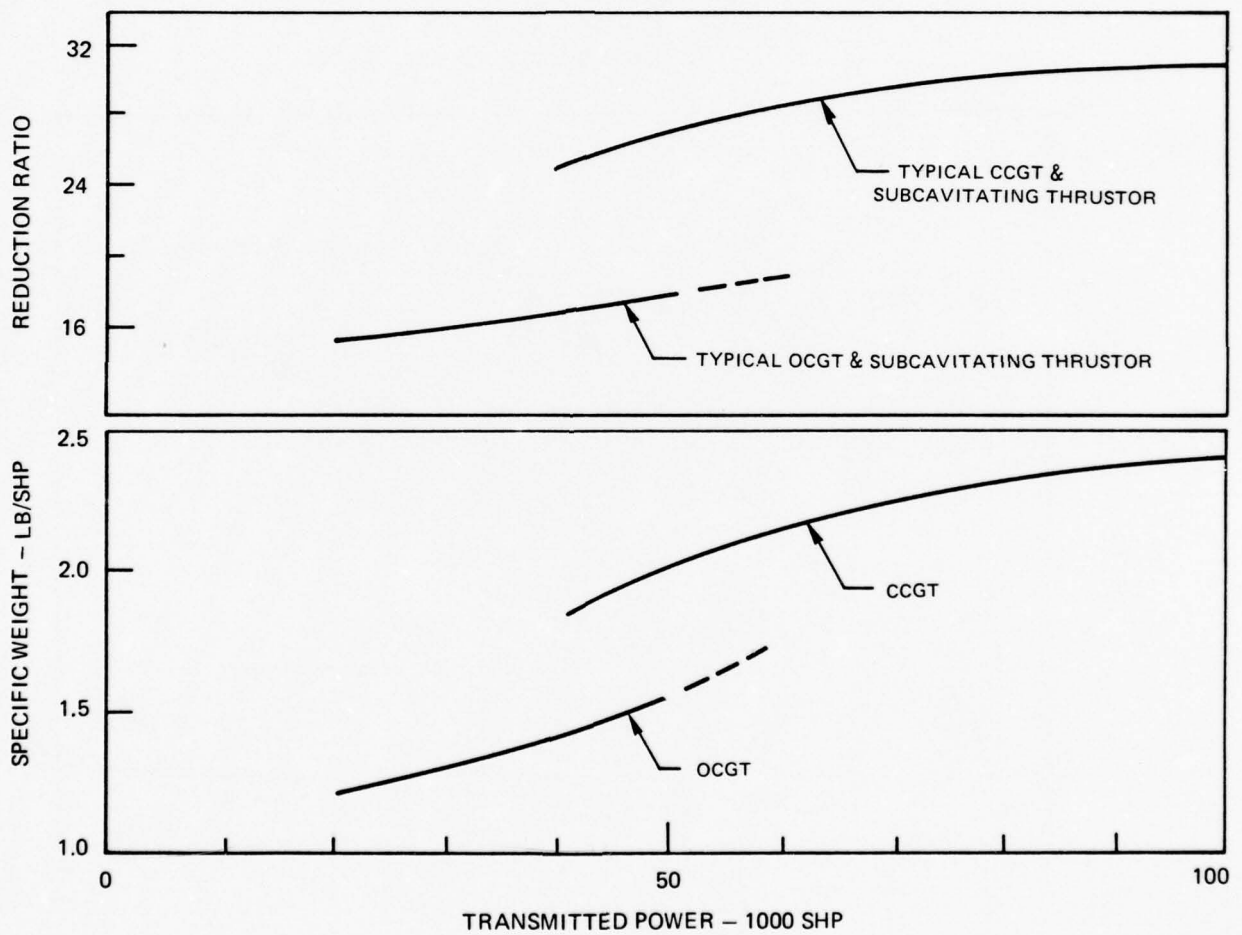

ESTIMATED SHAFT SPECIFIC WEIGHT

DIAMETER RATIO: 0.65

STRESS: 10000 PSI, CONVENTIONAL SHIPS

12000 PSI, 50- TO 80-KNOT SHIPS

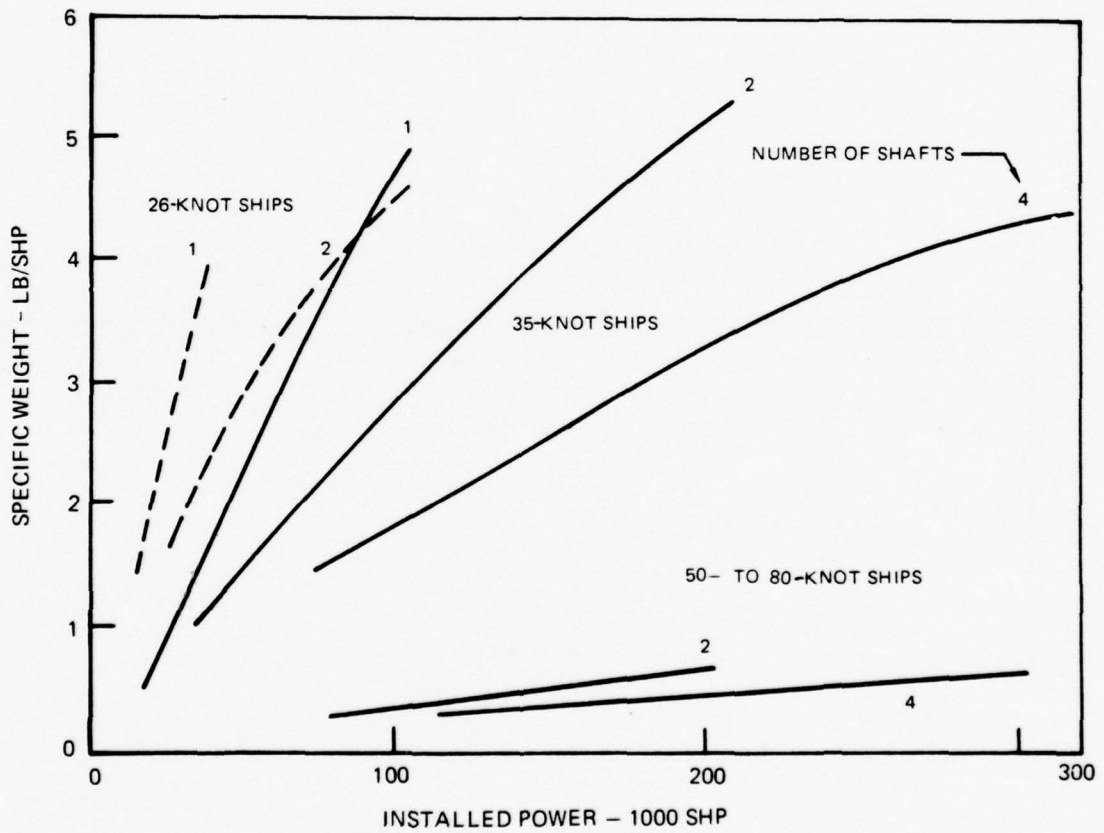

SECTION II

SELECTION AND DEFINITION OF PROPULSION PLANT ALTERNATIVES

The lightweight propulsion systems considered in this study for future naval ship applications would utilize fossil- or nuclear-powered Brayton cycle engines integrated with lightweight transmissions and thrusters. In order to reduce the number of such propulsion system alternatives considered in this study program to a manageable level, a preliminary screening procedure was used. Thus, the most promising alternative propulsion systems were identified for the ship types selected in Section I.

The selection of propulsion systems was based on the assumption that projected advanced component technologies would be available for general use in the 1990 time period for the naval ship applications considered.

Identification and Integration of
Propulsion System Requirements and Assumptions

To attain the goal of identifying the most promising lightweight propulsion systems, it was necessary to establish a set of general requirements and constraints pertaining to the technological level, performance, size, design criteria, operational requirements, environmental effects, and economics for these propulsion systems. These are identified in Table II-1. All specific requirements for ranking and then selecting the candidate engine cycles, transmissions, and thruster configurations were based on these general requirements. (It is emphasized that since estimation of the characteristics for the external fossil and nuclear heat sources, i.e., heater and nuclear reactor, respectively, was considered beyond the scope of this Part I study, only the potential impact of these components on the propulsion systems analyses was considered.) Also considered were requirements and constraints peculiar to the selected ship types which ultimately affect the attractiveness of each propulsion system. The critical aspects of these ship-to-propulsion system interfaces were identified and used in the system evaluation. These interface factors include cruise power requirements, engine room size and location, maximum power requirements, allowable propulsion system weight fraction, reverse power requirements, redundancy, vulnerability, noise, specific weight, specific volume, efficiency, and cost.

General Requirements and Constraints

The conversion of fossil or nuclear energy to thrust power for ship propulsion can be achieved with the use of any one of a large number of combinations of different engines, transmissions, and thrusters, with each representing its

own peculiar complexity, stage of development, and level of technology. This study has been undertaken to examine only three alternate system configurations utilizing both open- and closed-cycle gas turbines integrated with fossil or nuclear fuels. The systems considered were constrained by the requirements and assumptions given in Table II-1. Two of the most significant of these constraints are: that the propulsion system power generation must be within the range of 40,000 to 300,000 shp; and that the technologies required for the system must be in such a state of development that they could be placed into production by the 1985-1990 time period.

A driving consideration is the uncertainty surrounding the future availability of oil-derived fuels such as those currently used on both steam and gas turbine ships. A propulsion system which incorporates efficient, lightweight machinery components possibly could allow the ship to carry more fuel and thus be less dependent on the strategic location of refueling depots. Alternatively, a propulsion system which is more efficient than that which it replaces, but weighing the same or less, could allow even more range to be attained and/or greater refueling flexibility to be realized. Obviously, a nuclear-fueled system would be virtually independent of refueling requirements, but system weights (including reactor) must be reduced from current levels so that destroyer-size ships could be considered without having to make operational compromises. Capital and/or operational costs must also be considered in view of budgetary constraints which could make smaller, simpler, and less-expensive ships of same mission capabilities more desirable than large and expensive vessels.

In combat ship applications, the propulsion systems should be able to demonstrate low noise levels, quick response times, and low vulnerability. In peacetime, the same systems must be capable of extended operation with low operating and/or initial costs and a minimal effect on safety and environmental considerations. Propulsion system layouts should be reasonable in order to allow for easy comparison with existing systems in assessing overall value. The layouts and arrangements considered in Part I of the program are therefore similar to those of conventional propulsion systems where no more than four thrusters or six engines are allowed and where overall shaft speed reduction ratios are maintained at reasonable levels of less than 40:1.

Interface Requirements and Constraints

The purpose of the propulsion component of the system is to generate thrust, the force required to accelerate a vessel, maintain the vessel at a desired speed, or slow it through a reversing action. In general, this thrust is very large at the maximum speed of the ships selected for this study; for example, it takes approximately 500,000 lb of thrust to maintain a destroyer at a speed of 35 knots. Furthermore, the applied thrust on a combat ship has to be easily and quickly modulated and even reversed in order to meet many mission requirements. The propulsion system for combat ships must be able to meet these requirements yet continue

to operate efficiently and for long periods of time at cruising speeds which only require 5 to 15 percent of maximum power output as illustrated in Fig. II-1. (Only surface effect combat ships and auxiliary ships require as much as 60 percent of total power at cruise operating conditions, since their cruise speed is generally much higher relative to maximum speed than are the cruise/maximum speed relationships of displacement hull vessels.) Unfortunately, the equipment required to provide maximum thrust is large, whereas, the space and weight allotment for the propulsion system on combat ships (particularly destroyers) must be kept as small as possible. Thus, there has been a long-standing dilemma of contradictions in combat ship propulsion requirements.

From a broader viewpoint, the ship must be able to carry an acceptable payload for it to be considered a viable vehicle on a given mission or over a given duty cycle. Twenty percent of the total loaded vehicle weight (displacement) devoted to payload has often been a minimum goal for navy ships, although some designers of current high-performance ships appear ready to compromise payload for performance and accept or submit to payload percentages closer to ten percent. In this present study, a definitive assessment of acceptable payload has not been made, but rather the maximum possible payload variation resulting from propulsion system and duty cycle changes have been provided for evaluation by the ship customer. Payload is defined here as that portion of disposable load consisting of weapons and crew plus their required weapon support equipment (electronics, computers, airplane fuel, etc.).

Payload Allocation

The payload represents only one fraction of the total weight and volume of a ship. As shown in Fig. II-2, structure and fuel, as well as propulsion system equipment, must also be considered when analyzing the complete ship weight. Thus, a total propulsion system weight and volume estimate must include allowances for both the component equipment and the fuel required. The estimates for structure weight fractions presented in Table II-2 include the equipment listed at the bottom of that table. Typically, one-third to one-half of total displacement is represented by shipboard components in the structure category. These fractions were used for parametric analysis of the ship types studied in this program.

The physical structure on past and current conventional ships has often been designed to provide an impressive factor of safety, but this has been undertaken by the addition to both the total structure weight and the propulsion-system-related supports. Use of aluminum, titanium, and combinations of aluminum/steel composites is being demonstrated on high-performance ships and if successful should be equally applicable to conventional ships. However, it appears clear that the integrity of the hull in a conventional ship must be given due consideration in view of the explosive loading that it could encounter. Consequently,

in this study it was assumed that reductions in structure weight would be made by judicious incorporation of high-speed-ship technology, and also that similar weight saving measures would be taken into account during the design of propulsion-system-related components such as ducting, bed plates, and service equipment.

The conventional combat ships selected for this study should have the ability to make an ocean crossing without refueling. Such a mission might be undertaken at a speed that is determined to correspond to maximum range for each ship in actual operation. Often, this speed is near 20 knots, and therefore, for convenience, 20 knots was established for "cruising" speed for all displacement ships. At this speed, the ships should attain the ranges indicated in Table I-2. The fuel needed to attain the desired range is often places the most severe limitation on payload.

The specific fuel consumption values of most propulsion systems at cruise speeds (see Fig. II-3) make attaining this range while maintaining a reasonable payload a particularly difficult task. Fortunately, the most efficient operating line relationship of output shaft speed versus power for an open-cycle gas turbine is very close to the speed-power operating line of typical propellers. This relationship, shown in Fig. II-3, indicates that small improvements in fuel usage can be attained with CRP propellers compared with the performance of fixed-pitch propellers since the former type allows the gas turbine to operate at its most efficient conditions with only small losses in CRP performance (Ref. II-1). However, a more important fact shown in Fig. II-3 is the rapid increase in specific fuel consumption as shaft speed is reduced. For a conventional combat ship (35 knots maximum) cruising at 20 knots, a single open-cycle gas turbine (per shaft) would be operating at approximately twice the specific fuel consumption it would be able to attain at full power. The desire to lower this fuel use characteristics has been the driving force behind many propulsion system designs.

Propulsion System Arrangements

Different marine propulsion system arrangements have been utilized to minimize fuel use at cruise conditions, and frequently, the cruise engine concept, similar to that shown in Fig. II-4 (upper) is used. In foreign naval ships the cruise engine is often a diesel while in U.S. Naval vessels, where total steam propulsion systems are used, a small cruising steam turbine is often employed. The DD963 and FFG7 ships have taken a somewhat different approach as illustrated in Fig. II-4 (lower). In those ships, one of the twin engines is shut off during cruise operation, thus producing a saving in fuel due to improved engine specific fuel consumption at the cruise condition. This improvement can be seen by reviewing data in Fig. II-3 where it can be seen that for a given output speed, when the power output of a single engine is doubled, the specific fuel consumption is reduced. This procedure can be continued until the fuel flow (or turbine inlet temperature) to the engine remaining in operation reaches its maximum fuel flow limit which is also shown in Fig. II-3. During the present study, the highest safe power level at which this arrangement could operate on one engine per thruster was limited to the condition where the total shaft power requirement was 40 percent of maximum shaft power.

Propulsion System Layout

Another ship-propulsion system interface is the required location and size of engine rooms since this will affect the shaft length (and weight) as well as the geometry of system components. Naval architects must consider the weight and location of the propulsion system in establishing stability and metacentric height. The most likely combat damage and its severity based on predictions from statistical methods also affect engine room location. The prime movers on most U.S. combat ships are usually placed in individual engine rooms separated by two or more watertight bulkheads. As an illustration, the DD963 layout shown in Fig. II-5 has three watertight bulkheads between engine rooms. For a similar reason, inlet and exhaust ducts normally are not directed through the bulkheads until they reach the main deck. Many unusual arrangements and shafting requirements are associated with SES, hydrofoil, and other similarly unique ship types. Current U.S. and Canadian hydrofoils are good examples of these complex requirements while a discussion of many other layouts is given in Appendix D. Several standard layouts were selected for analysis which are illustrated in Appendix D, and the effect of these have been included in the estimates of shaft weight shown in Fig. I-17. In all cases, spacing of 40 feet between bulkheads was assumed standard.

Overview of Controls and Maintenance

The control and maintenance of the propulsion system must be taken into consideration during ship design and propulsion system selection. Open-cycle gas turbines and other automated systems such as steam turbines can be operated directly from the bridge or from the engine room as conditions dictate. In a more complex advanced system, such as the CCGT, control of heat rejection and of thermal gradients in heat exchangers may dictate the need for additional development of control systems in order to attain the level of automation available in current open-cycle gas turbines. Combat ship maintenance often must be totally performed aboard ship since accessibility and removal of large components from the ship may be impossible without cutting a hole in the deck or passing them through the duct work.

Finally, since ships must be operated over a variety of weather conditions and a spectrum of sea states, the propulsion system must operate over a considerable range of list, trim, and shock loading condition. For example, sumps that collect lubricating oil onboard ship may have to be designed to be relatively deeper than otherwise might be required for stationary applications. Internal and external support structure must endure severe shock loading, and air intakes are likely to ingest some amount of sea water in the form of entrained spray. These and many other portions of a marine power plant are thus apt to be exposed to the corrosive and severe environment and effects of the sea.

Identification of Critical and Projected Technology

In an effort to estimate the attractiveness of a propulsion system assumed to be available by 1990, an evaluation of the critical technologies and their future levels of development as they relate to competing systems was undertaken. Current levels of performance were established from literature surveys and discussions with private consultants. Experts in these fields from the Pratt and Whitney Aircraft Group, the Turbo Power and Marine Systems Subsidiary, the Power Systems Division, the Hamilton Standard and the Sikorsky Divisions, all of the United Technologies Corporation, were contacted to obtain estimates of future system performance capabilities.

Propulsion engines of the open- and closed-cycle gas turbines and transmissions and thrusters of the types identified in Section I were included in these estimates. However, in this phase of the study, specific projection for the characteristics of fossil heaters and advanced nuclear reactors, both of which are crucial components requiring extensive research and development, were not made. Instead, these components were treated on a sensitivity basis in order to predict the effect that their potential characteristics would have on system applications.

Open-Cycle Gas Turbine (OGCT) Technology Assessment

An examination of specific gas turbine component limitations revealed that turbine cooling technology and material temperature and sulfidation and corrosion limits are the most crucial factors governing OCGT design considerations. The projected advances in OCGT operational capabilities and performance characteristics, such as turbine inlet temperature (TIT), specific fuel consumption (sfc), continuous power capability (shp), and specific weight (lb/shp), were established from a survey of existing engines and projected capabilities for engines anticipated to become available during the next fifteen years.

State-of-Art and Critical Technology Projections for OCGT

Rapid advances in open-cycle gas turbine technology have been made over the past 20 years, and these have been a result, primarily, of military aircraft requirements. The total unit output power capacity has increased by at least ten-fold during this period with specific weight, volume, and power having also been improved correspondingly. The technologies on which these improvements have been based are now reasonably well defined in most cases. However, as it might be expected, the future rate of technological progress may not be advanced at this historical rapid pace.

As is well understood, both overall cycle pressure and peak cycle temperature limit the maximum thermodynamic efficiency attainable by a gas turbine. Current engines operate with maximum cycle temperatures near or above the melting point of the engine metals, and are even near or above the upper operating limits of some ceramic materials. The allowable metal temperatures shown in Fig. II-6 for current and projected superalloys dictate that cooling must be used, yet this requires diverting compressed air from the main flowstream upstream of the combustor and requires that additional work must be performed by the turbine, as well. Recent predictions (see Fig. II-7) relating to the cooling of metal turbine parts using the latest conductive, convective, film, and transpiration techniques, indicate that approximately one-third of the total compressor air-flow may be required for operation at a maximum cycle temperature of 2500 F and at pressure ratios above 16 to 1. The cooling requirements increase rapidly with further increases in turbine inlet temperature and cycle pressure ratio. Thus, it can be easily understood why studies and development programs considering temperatures higher than this level have encountered difficulty in producing a practical engine design.

Based on this background, either a means of reducing cooling requirements or setting limits on maximum cycle temperature will be required for marine powerplants. Ceramic materials appear to offer potential for reducing the cooling air requirements, but the use of these materials will be limited until a better definition of "acceptable material properties" is obtained.

Of particular interest is the application of ceramics technology to rotating part designs, for long-life gas turbines. It is believed that such technology will not be available until after 1990, and therefore, ceramics have not been considered for gas turbine internal hardware components. Thus, the increased turbine inlet temperature experienced during the last 15 years as shown by data in Fig. II-8 is not expected to continue at the same rate in the forthcoming fifteen years. As a result marine systems expected to be in operation in post-1990 are expected to attain maximum cycle temperature of no more than 2600 F.

Marine and industrial applications are limited to lower maximum cycle temperatures than other applications, as illustrated in Fig. II-8. This is due to the fact that in order to achieve long life, low cost, and highly reliable operation, sacrifices in performance and/or weight must be accepted. In longer-life gas turbines, metal temperatures must be maintained at lower levels, thereby requiring more cooling for a given maximum cycle temperature. Another severe restriction to turbine life is the sulfidation and corrosion problems that accompany engines operated in a marine environment. Currently, many designers feel that 1500 F is the maximum safe metal skin temperature which can be allowed in the hot section of marine gas turbines. The development and use of new coating, materials, and cooling concepts should allow a skin temperature of 1600 F to be used for 1990

marine engine applications. The effects of this skin temperature limit on cooling flow, maximum reasonable cycle temperature, and cycle pressure, has already been included in the turbine inlet temperature forecast in Fig. II-8.

Projections for overall pressure ratio and compressor stage performance, presented in Figs. II-9 and II-10, are not the result of inherent compressor limitations, but rather they are restricted by the technology level which accompanies the limited maximum cycle temperature as shown in Fig. II-8. Further expensive development of compressor technology may not be warranted for marine applications until the turbine corrosion and cooling technologies are improved. For simple-cycle engines, a pressure ratio exceeding 30 to 1 does not seem warranted.

The specific fuel consumption and the specific power (shp per unit airflow) of open-cycle gas turbines, shown in Figs. II-11 and II-12, have also improved significantly in the past 15 years. Again, due to the present high level of technology which has been attained by gas turbines, further advancements will be much more difficult to attain. A much larger potential for improvement is possible when an OCGT is mated with a waste heat boiler and a steam turbine in what is generically described as a combined-cycle (or COGAS) system.

Projected OCGT Availability in 1990

The technological advancements described in the previous section were used to estimate the progression of detailed engine design parameters as shown in Table II-3. Existing and proposed engine designs were also reviewed to estimate their future power, efficiency, and size capabilities. This information indicates that a wide spectrum of aircraft-derivative gas turbine engines might be available in 1990, and a list of the candidate models is shown in Table II-4. These engines could result from continued manufacture of an old design, production of a slightly or drastically modified present design, or the development of a completely new design. The power level of a completely new design was selected to be 60,000 shp since, at this power level, there is little competition from the larger industrial-derivative engines. Furthermore, an advanced engine design of this rating would be a fairly logical step in adapting a large commercial aircraft engine for marine use. However, it must be recognized that such a development program would require massive funding from private industry or government sources to achieve production status by 1990.

The specific weight of a gas turbine depends to a large extent on both the structural design philosophy followed and specific power achieved. Based on a survey conducted during this program, the results shown in Fig. II-13 indicate that a steady reduction in specific weight has been achieved during the past 15 years. For reasons similar to those cited for other system parameters noted previously, the rate of improvement is projected to slow in the next decade. Furthermore, this reduction in specific weight likely will not be as significant as the weight

added to the basic aircraft-derivative gas generator through the incorporation of a power turbine and all of the other related equipment and support structure included in a typical mechanical drive package. The application of lightweight design philosophy to these other components of the mechanical drive package could lead to a continued downward trend in the specific weight of the entire system during forthcoming years. However, significant weight allowances will still be necessary for certain parts of this equipment since exogenous conditions beyond the control of the propulsion system designer alone often dictate the total ship installation requirements.

The specific weights associated with gas turbines designed exclusively for industrial applications (see in Fig. II-13) reflect, the industrial engine design philosophy which accepts greater weight to achieve performance improvement. Since this present study program is intended to evaluate lightweight propulsion systems, and since many combat ship crews would experience difficulties handling or removing the large (80,000 to 120,000 shp) heavy industrial engines available during typical on board servicing, the derivatives of industrial engines applied to marine applications have not been considered in this program.

In summary, OCGT availability in 1990 will be assumed to be based on the continued development of existing or (near-term) proposed engine designs. No entirely new engine development program directed primarily at marine applications is foreseen, and hence, the maximum engine size is projected to be 50,000 shp.

Closed-Cycle Gas Turbine (CCGT) Technology Assessment

Since it was first proposed by Drs. Ackeret and Keller in 1939, the concept of the closed-cycle gas turbine has become well developed, and related technologies are currently available for unit sizes up to 67,000 shp (50 MWe). Since the first commercial closed-cycle gas turbine was built in Ravensburg, Germany, more than a dozen fossil-fired units have been built and operating successfully mostly in Germany, while a few units have been built in Russia and in Japan. Although no nuclear-fueled CCGT plants have been built to date, there are a number of conceptual designs which have been proposed in company reports and in a variety of periodicals. It has been suggested repeatedly that because of their potentially high efficiency large unit capacity, and low specific weight and volume, CCGT systems can be integrated with either fossil or nuclear heat sources to generate electric power efficiently, as well as to provide ship propulsion. The state of the art and the expected advancement in closed-cycle gas turbine technologies, particularly in terms of operating temperature, unit capacity, heat exchanger performance, material capabilities, and system lifetime, are being identified in this section.

State of the Art of CCGT

Ideal closed-cycle performance is limited from a thermodynamic standpoint by the same factors as is that of an open-cycle engine since both are Brayton cycle systems. Therefore, turbine inlet temperature and pressure ratio again are determining factors. However, since closed-cycle systems must include heat exchangers, the pressure loss associated with these components is also a limiting factor.

A survey of turbine inlet temperature and unit capacities for existing closed-cycle gas turbines was made, and the results are presented in Figs. II-14 and II-15, respectively (see Ref. II-2). All CCGT systems in operation are fossil-fueled, and therefore, their turbine inlet temperatures are dictated by the gas (air or helium) heater design limitations. The United Technologies Corporation has been involved in a number of evaluations of closed-cycle systems (see Table II-5), dating back to space power applications in the early 1960's. The engine illustrated in Fig. II-16 was designed and built during this period and is believed to be still undergoing testing by NASA. Engine design concepts presented in Figs. II-16 and II-17 were aimed at possible space and utility power applications.

Although closed-cycle gas turbines using helium gas are not in commercial use, the higher specific heat of helium compared with that of air (a ratio of approximately six) allows flow path sizes and pressure ratios to be considerably reduced (relative to those of air) at comparable levels of output power. Since the same fabrication and design considerations affect the size and geometry of turbomachinery, the relatively higher transport properties of helium allow much higher power ratings to be achieved when using helium rather than air as the working fluid. A greater appreciation for this effect can be gained from reviewing the illustrations in Fig. II-17 which compare several OCGT and CCGT designs drawn to the same scale.

Critical Technologies of CCGT

In general, the design problems associated with the open-cycle gas turbine are also those associated with the closed-cycle gas turbine. Obtaining a good engine balance, isolating critical speeds from the operating range, controlling seal clearances, and minimizing flow leaks are examples of common problems. These areas are the subject of on-going technology improvement, and both open- and closed-cycle designs will benefit from the resulting technological advances.

There are a few areas of closed-cycle turbomachine technology that are critical to successful designs, and these can be related directly to the inert nature of the working fluid and the high internal pressures. Helium is the working fluid which most likely would be used in closed-cycle systems in the range above 100,000 shaft horsepower because of its excellent heat transfer properties,

chemical and radiological inertness, and abundance in nature. The chemical inertness does present a potential problem because it is not possible for an oxide film to form on mating parts and in areas where contact stress and/or temperatures are high. As a result, self-welding of mating parts may occur. Subsequently, fluctuating operating conditions could cause these welds to fail, and in the process could create stress concentrations that result in structural failure. Also, since long-term creep properties of most turbine materials in helium atmosphere are unknown and require definition, both self-welding and fundamental metallurgical property variations require investigation.

A limited investigation is in progress on metallurgical effects in Europe (Ref. II-3) and contracts for similar studies in the U.S. have recently been awarded by ERDA (Ref. II-4). These programs should provide general insight into helium effects, but even with these, the need for specific testing of turbine materials at typical operating temperatures is only beginning to be addressed. Some qualitative data is being obtained on both self-welding and material properties in the Oberhausen II powerplant in Oberhausen, Germany. Data from this installation and more limited testing in the HHV facility in Julich, Germany should be available starting in 1978 (Ref. II-2). Accelerated test programs in the U.S. on the special operational problems of gas turbine materials in a contaminated helium environment are not currently scheduled, and if closed-cycle systems are ever expected to be accepted, testing in helium atmospheres must be conducted early in the closed-cycle development program.

Another technology area where little is known and which may be essential to marine application of the closed-cycle gas turbine is that of missile containment. At ratings of 100,000 shp or greater, closed-cycle gas turbines operating between pressures of 450 psi and 1000 psi could be highly destructive to a ship if a gas turbine disk should fracture and penetrate the outer pressure vessel of the system or the surrounding ship spaces and hull. Missile containment structures have been designed using currently accepted techniques, Ref. II-5, but no data exist to verify this method for large, relatively low velocity missiles such as those which would be generated by machines of sizes 100,000 shp and above. Studies of the problem of missile containment in aircraft engines are in progress and may provide phenomenological data, but there is serious doubt as to whether these aircraft studies will overlap the regime of the closed-cycle high power gas turbines. Tests specifically related to the large turbomachines are not now scheduled but would be a necessary part of the development program of such machinery.

In the case of a fossil-fired, closed-cycle system, the high-pressure, high-temperature heat exchanger is a limiting technology item. The operating condition of 1500 F and 1000 psi requires expensive materials to maintain strength and control fireside corrosion. EPRI and ERDA have awarded some contracts to study the effect of fireside corrosion on heat exchanger materials (Ref. II-6) but extension of turbine inlet temperature to 1600 F or higher would require new heater technologies

to meet the same kind of material temperature and corrosion problems present in OCGT. Ceramic technology has a much greater probability of being made available for heaters by 1990 than for OCGT components and low-cost "throwaway" concepts or other methods may be used in resolving the high cost resulting from short-life associated with high-temperature operation. The follow-on Part II study will examine these problems in sufficient detail.

There are two other areas of technology which are pertinent to successful application of closed-cycle systems to ship propulsion. These are the problems of acoustics and internal aerodynamics. Gas turbines generate both discrete frequency noise and "white" or broad spectrum noise during operation. Considerable research has been conducted on this subject using air as the working fluid, and the General Atomics Corporation has obtained some operating data in helium from their Fort St. Vrain circulators. The sound pressure levels that are tolerable inside the engine spaces onboard a ship may require application of noise reduction techniques, and consequently, the accurate prediction of acoustic energy levels and frequencies is a necessity for defining and solving this problem. Depending on the nature of the shipboard installation, it may be necessary to develop new technology in acoustic energy abatement techniques (in helium) and to verify the applicability of data obtained from investigations in air. Presently there are no known U.S. programs planned in this area.

The field of internal aerodynamics has been widely investigated both in the U.S. and abroad, and these studies provide a broad base for estimating the pressure losses and defining the duct/scroll configurations for closed-cycle turbomachinery. Closed-cycle turbomachinery. Closed-cycle performance is quite dependent on internal pressure losses, and techniques for minimizing these losses in a system with sharp bends and abrupt area changes will probably need further development. Progress in this area will probably parallel that of similar equipment in fields such as electric power generation and energy storage.

Another feature of major technological concern is the requirement to vary engine shaft speed in a mechanical drive system. In principle, speed can be varied in turbomachinery for closed-cycle powerplants and can thus be used to modulate power and efficiency. In actual practice, large, single-shaft machines used in helium tend to have many stages and to be relatively long, and therefore these have normally been designed for constant-speed operation at a super-critical rotor speed. Machines of this type have been intended for utilities where speed changes normally are encountered only during start-up, shut-down, or drop-load conditions.

For marine applications, the relative merits or complexities of constant-speed and variable-speed prime movers must be considered very carefully. This clearly involves transmission and propeller characteristics and the range of speeds to be considered in normal operation. Hence, very large number of variations, trade-offs, and compromises is possible. This could include a reduction in cycle pressure ratio

to reduce the number of stages and make the turbomachinery more adaptable to variable-speed operation. Alternatively, a two-shaft configuration having a free turbine is possible. At the very least, the powerplant and its drive train must provide some means for disconnecting the propulsor in an effective manner and also for driving it throughout a suitable speed range.

Control methods will have to be evaluated, and a combination of temperature control, bypass control, and inventory control may be required. However, these methods could cause a complex control problem involving parameters such as inter-related fuel flow rates, valve and pump reaction rates, and gas path stall and resonant speed avoidance. Establishing a workable control system could therefore require substantial development and testing.

Some areas of closed-cycle systems that are not considered as requiring the application of critical technology, in contrast to those in open-cycle systems, are turbine materials, anti-corrosion coatings, and turbine cooling. Material technology can affect the design in terms of life predictions for blades due to accumulated growth since the closed-cycle gas turbine operates in a controlled environment using a clean working fluid at turbine inlet temperatures which are moderate (1500-1700 F) relative to current open-cycle gas turbine technology. As a result, the CCGT does not require sophisticated turbine cooling concepts and therefore, it is expected that creep life rather than operating damage will be a primary concern in system operation. Airfoils could be designed for operating lifetimes in excess of 30,000 hours if accurate material properties are available. However, any estimates for material creep life greater than 1000 hr are usually based on prediction methods for which little supportive laboratory test data are available. It is likely that, only operational experience will determine the validity of these assumptions since performing controlled tests for such a long period of time would be impractical and expensive.

Projected CCGT Technology

The projected maximum turbine inlet temperature for long-term closed-cycle gas turbine operation beginning in the 1985 to 1990 period is estimated to be between 1500 F (816 C) and 1600 F (871 C), depending on the types of heat source used and the system lifetime required. Both the United Technologies Corporation test results and the materials research carried out within the German HHT project to date indicate that technologies for turbine inlet temperatures up to 850 C (1562 F) at operating lifetimes of 40,000 hours are currently available; for a higher TIT, intensified cooling and use of ceramic material for gas duct insulation may be necessary. However, the performance capability of a fossil-fired CCGT propulsion engine will be limited by the temperature capability of the gas (helium) heater; this limit is currently approximately 800 C (1472 F) although progress is expected during the next 15 years. In addition, compressor pressure ratios of 4 to 1 should allow CCGT sfc to exceed those of the OCGT while not requiring excessive turbomachinery or large improvements in pressure losses due to heat exchangers and ducting.

A careful examination of the size and weight characteristics for existing closed-cycle gas turbine power systems leads to the conclusion that implementation of technologies available for large aircraft-type turbines will be imperative if lightweight CCGT systems are to be developed for naval ship propulsion applications. Development of advanced materials and cooling schemes for increased TIT and lightweight composite materials for the cooler engine sections will apparently continue. Although the CCGT plants built to date are all under 67,000 shp in capacity, conceptual designs already carried out at UTRC and elsewhere have ranged from 100,000 to 1,300,000 shp per unit, and unit capacities as large as 2,000,000 shp seem to be feasible.

For the units rated between 40,000 and 300,000 shp in Part I of this study, simple tube-and-shell heat exchanger characteristics will be used. The values of the turbomachinery stress, geometry, and loading parameters which are summarized in Table II-6 were maintained at levels comparable to those identified for the CCGT design presented in Table II-3.

The detailed projection of the effect of this technological level of achievement on the characteristics of the closed-cycle engine is one of the primary objectives of this study. Section III presents these projections as a result of parametric evaluation and integration into the whole propulsion system.

Propulsion System Component Technology Assessment

Projected improvements in gearbox, shafting, and thruster technologies and the effect these capabilities can have on characteristics of system capacity, weight, and efficiency are identified in this section. Table II-7 summarizes the projected characteristics and assumptions relating to the primary propulsion system components which affect the selection of propulsion system configurations and arrangements to be studied.

In open-cycle gas turbine systems, improving the limitations to operating life caused by corrosion, and increasing the ability to operate on other than refined or treated fuels, are seen as the most significant future operational considerations. Closed-cycle gas turbines rely heavily on heat exchanger and heater performance, and hence, improvements in temperature capability, effectiveness, cost, and size of heat exchangers are critical. The actual internal flow dynamics of helium ducting, valving, and system control will require extensive verification before closed-cycle gas turbines can be incorporated in fleet ships.

In gearboxes the use of surface hardening or nitriding of gear teeth, rather than the use of through-hardening, may have to be used more extensively, and concepts such as epicyclics or unusual gear arrangements will require further tests before being confirmed for fleet use. Gear tooth loading (both compressive and bending stresses) should also be considered an area where future improvements are possible. Shaft stresses of up to 12,000 psi will be required, and dynamic instabilities of shaft-support systems at high rotational speeds will have to be prevented through careful design and development of shafts, bearings and supports.

In the realm of thrusters it will be necessary only to make minor improvements in fabrication capabilities relative to present commercial production capabilities to achieve the capacity and performance projected for fixed pitch subcavitating propellers. However, for the CRP propeller, careful evaluation of designs and verification of blade design stress capabilities will be necessary in order to achieve the power and performance levels projected. Operational overloads caused by pitch changes while underway presently restrict CRP thrusters from achieving their full potential, and this area will need further development as well. Supercavitating propeller applications would greatly benefit from an increased ability to predict and attain high levels of both design and off-design efficiency. It appears that only through increased development, testing and manufacturing efforts on the part of the marine industry will technology be improved and the forecast high power capacities and performance capabilities be achieved. Water jets are subject to many of the same technology requirements as are supercavitating propellers, and although these can be minimized by flow path control, they are made more complex by inlet and multiple-stage flow interactions.

As a result of these considerations the following component limitations were established. Offset gearboxes will likely be limited to 150,000 total shaft horsepower transmitted through a single unit (an extension from the current capacities of approximately 100,000 shp). Epicyclic gearbox capacity is projected to increase from current 40,000-to-50,000 shp level to 100,000 shp by 1990. Fixed-pitch propellers of the subcavitating variety should have no difficulty handling 100,000 shp by 1990. In contrast, for fixed-pitch supercavitating propellers to progress from the current maximum of approximately 20,000 shp to the projected 100,000 shp will require considerably more effort although no insurmountable obstacles are foreseen by hydrodynamicists. Ratings of subcavitating CRP propellers are projected to be extended from the current 40,000 shp maximum capacity to a level of at least 60,000 shp by 1990. This should be possible through a normal extension of technology for subcavitating applications whereas, supercavitating propeller designs will require a more concentrated development effort to attain the same capacity.

Selection of Propulsion System Sizes and Arrangements

The three alternative propulsion system configurations selected for evaluation in this study consisted of an open-cycle gas turbine with a fossil-fueled combustor, a closed-cycle gas turbine receiving energy from a fossil-fired heater, and a closed-cycle gas turbine integrated with a nuclear heat source. The gas turbines were coupled with several mechanical transmission systems and water thrusters to provide a large number of potential system arrangements to satisfy different ship performance requirements. From among this array of choices, a manageable number of arrangements was selected and baseline engine sizes required were identified for evaluation in subsequent parametric analysis.

Propulsion System Configurations

It is the intention of this program to study propulsion systems which could provide improvements in ship performance or cost by making reductions in system weight. Gas turbines have long been recognized as capable of providing lightweight, compact power and therefore, they form the basis for all of the configurations considered. The helium closed-cycle gas turbine system should be able to achieve a much higher efficiency than that of a simple cycle gas turbine engine when both systems are operated at the same turbine inlet temperature. This concept presents an attractive scenario whereby a closed-cycle configuration, consisting of a lightweight, efficient turbomachine, immune to environmental corrosion problems, could be operated at metal temperatures which should provide relatively trouble-free, long life. Furthermore, since the working fluid in a closed-cycle system does not consist of the combustion products, a large variety of heat generating methods or fuels theoretically can be selected vis a' vis those for the OCGT. This closed-cycle arrangement then provides an attractive alternative scenario to that of direct use of the open-cycle arrangement. The alternative configurations and candidate components used are summarized in Fig. II-18. Conceivably, all configurations could use any of the transmission and thruster concepts shown to meet specific ship requirements.

Propulsion System Arrangement

The spectrum of ship and engine power combinations being considered could lead to an extremely large combination of engines, gearboxes, and shafts unless discrete power levels and arrangements are chosen. Eight levels of installed power between 40,000 and 300,000 shp were selected after consultations with naval experts. These levels, shown in Fig. II-19 are spaced such that all the selected ship types, except auxiliaries, are provided with at least two levels of power. Figure II-20 further indicates the levels of installed power for which one, two, or four number of thrusters of different types required for each of the installed power levels as well as the number of engines (limited to maximum power capacities discussed previously) required to drive these thrusters. Different combinations of these engine/thruster shaft numbers would imply the required gearbox configurations (for a given installed power) identified in terms of input/output shaft combinations.

Hundreds of arrangements and layouts of engines, gearboxes, and thrusters are still possible within the constraints outlined in Fig. II-19 and Table II-7. Therefore, the further assumption was made that ship installations requiring multiple thrusters would incorporate units of the same capacity and type and that each of these would be driven by identical engine-gearbox arrangements (except possibly for SES lift power requirements). It is possible that this restriction could eliminate some unconventional installations incorporating different arrangements of multiple thrusters and engine sizes or types which could produce better performance in a specific ship type. However, it was not the purpose of this study to compare different propulsion system arrangement but rather to evaluate potential new propulsion engines within a framework of consistent assumptions.

Five basic arrangements selected for study as shown in the left column of Fig. II-21 would practically cover most engine and thruster shaft combinations possible. Multiples of one, two, or four of each arrangement were then used to achieve the eight (8) installed power levels shown. Engine, gearbox, and thruster limitations shown in Table II-7 were used to estimate compatible installations. A further limitation was imposed by eliminating the use of a three-thruster-per-ship arrangement since there are very few existing ships which would allow a reference comparison to be made versus the results projected for such a future system. These considerations reduce the number of installation combination possibilities significantly, but still there are over 100 different installation arrangements possible as shown in Fig. II-21.

From Fig. II-21 it can be seen that Arrangement A utilizes a single-shaft engine (direct drive) with no power turbine. This arrangement has not been used in open-cycle applications since such engines are limited in speed and are severely penalized in efficiency at part-power operating conditions. Closed-cycle engines utilizing a combination of bypass and inventory control methods may not be as severely limited when using this arrangement, and therefore this configuration was included primarily for CCGT to possibly achieve savings in weight, cost, and size.

Arrangement B allows a separate power turbine to be incorporated with the engine, and therefore it is applicable to both open- and closed-cycle engine applications. Arrangement C utilizes the gearbox to split engine power between two thrusters. It was primarily included for its application to closed-cycle engines, but it could be applied to open-cycle application when conditions allow.

Arrangement D splits the main gas turbine flow into two power turbines and will only be considered for CCGT systems since the power output of a single CCGT power turbine can greatly exceed the projected maximum thruster capacity of 100,000 shp. Arrangement E has become a standard gas turbine arrangement in the US Navy since the introduction of the DD963 and FFG7. Two identical engines are utilized to power a single thruster, thus dictating that CCGT applications using this arrangement are limited to comparatively low power output ratings per engine.

When limitations to the thruster and the gearbox shown in Table II-7 are applied to Arrangement C and D, maximum engine size is limited to 150,000 shp and 200,000 shp respectively. Whereas, it is projected that a single closed-cycle engine could be built which would provide the full 300,000 shp installed power, this would require splitting the power among at least three output shafts, since thrusters are limited to maximum power absorption of 100,000 shp. This would dictate either a very unusual gearbox, three engine turbines per main engine, or a combination of these. Problems could result with ducting, shaft centerline spacing, flow stability, control methods, and perhaps other factors. Therefore three output shafts per engine was not considered.

Both Arrangements C and D are unconventional for ship propulsion and could present some of the same problems noted for the three-output-shaft engine configuration. However similar concepts have been used in land and ship applications, and consequently it should be able to apply these to the ships studied. Thus Arrangements C and D are considered sufficient to accommodate large CCGT systems, and no more than two output shafts nor engines larger than 200,000 shp per unit would be required.

Baseline Engine Sizes Required

The selection matrix shown in Fig. II-21 also determines the power capacity required for individual engines to meet the selected installed ship power requirements. For open cycle gas turbines a total of four reference output power ratings, which are within the limitations shown in Table II-7, will fill the matrix possibilities identified. These engines will all be assumed to possess a free power turbine to drive the output shaft at power levels of 20,000; 30,000; 40,000; and 50,000 shp. Engines producing all four of these power levels should be possible by 1990 as a result of follow-on development of existing engines, such as the Spey, LM 2500, RB-211, FT9, FT4, LM 5000 and Olympus.

Closed-cycle engines, which are not restricted by the limitations presented in Table II-7 or as discussed in the previous section will sustain all the possibilities shown in Fig. II-21 if eight reference output power ratings are available. These engines will be considered with and without a free power turbine(s) producing output power levels of 40,000; 60,000; 80,000; 100,000; 120,000; 150,000; 160,000; and 200,000 shp.

Scope of System Evaluation

The narrowed scope of installations shown in Fig. II-20 still comprises a broad spectrum of characteristic component parameters for consideration. These parametric ranges as well as other important parameters considered are summarized in Table II-8. These characteristics are interrelated in a total propulsion system energy flow to produce thrust and power as shown in Fig. II-21. For the sake of bookkeeping the many combinations of parameters possible for the propulsion systems studied were identified by the coding system (shown in Fig. II-22), while the system cases considered in the parametric analysis are discussed in Section III.

REFERENCES FOR SECTION II

- II-1. Stewart, A. J.: Comparative Performance of High Efficiency Ship Propulsion Systems for Destroyer Hull Types. Bradford Computer and Systems, Inc. December 6, 1976. Contract N00014-74-C-0398, ARPA Order No. 2805.
- II-2. Kuo, S. C.: Recent Development of Closed-Cycle Gas Turbines and Gas-Cooled Nuclear Reactors in West Germany and Switzerland. United Technologies Research Center Report R76-952566-2. October 1976.
- II-3. Personal discussions between S. C. Kuo of UTRC and Dr. P. Zenker of EVO, Oberhausen, W. Germany, and Dr. H. V. Schlenker of KFA, Julich, W. Germany.
- II-4. ERDA Contract to General Electric for Precision Creep Tests in Heat Exchangers. 1976.
- II-5. Hagg, A. C., and G. O. Sankey: The Containment of Disk Burst Fragments by Cylinder Shells. ASME Paper 73-WA-PWR-2. July 18, 1974.
- II-6. EPRI Contract RP 543-1 on Establishment of Design Criteria for Alloys and Coatings with Resistance to High Temperature Erosion/Corrosion. P&WA October 1975. Also NSF Contract DMR75-19730 on Corrosion Mechanism of Alloys in Multi-Component Gas Mixtures. P&WA. February 1976.

TABLE II - 1

LWSPS GENERAL REQUIREMENTS AND CONSTRAINTS

- 1985-1990 technologies - fossil or nuclear powered
- Low sfc (< 0.4 lb/shp-hr) or high thermal efficiency ($> 38\%$)
- Low specific weight (lb/shp) and volume (ft^3/shp)
- Compatible maximum cycle temperature
- Heat rejection through fresh/salt water loops
- 40,000-300,000 shp range installed
- Four or less thrusters driven by six or less engines
- High system reliability, vulnerability, and maintainability
- Reasonable system lifetime ($> 30,000$ hr) and TBO
- Low initial and operating costs

TABLE II-2

SELECTED SHIP STRUCTURAL WEIGHT ASSUMPTIONS

<u>Ship Type</u>	<u>Max. Speed (knots)</u>	<u>Displacement (long tons)</u>	<u>Structural Weight (Fraction of Total Displacement)</u>	
			Reference Ship	Assumed
Aircraft Carrier	35	60,000	.61+.70	.60
Cruiser	35	12,000	.48+.59	.50
Conventional Destroyer	35	6,200	.42+.64	.45
High-Speed Destroyer	50	4,000	.57	.44
High Performance Ship (SES)	80	3,000	.41	.30
Auxiliary	26	32,000	.37	.35

Note: Total Structural Weight is Assumed to Include:

Basic Structure Weight

Group 300 Weight (Electrical Power Plant)

Group 500 Weight (Auxiliary Systems-Excluding Lift)

Group 600 Weight (Outfit & Furnishings)

Margin and Fixed Ballast Weight

Weight of Elevators, Catapults, Arresting Gear, etc (Aircraft Carrier).

TABLE II-3

TYPICAL OPEN-CYCLE GAS TURBINE DESIGN PARAMETERS

<u>Low Compressor</u>	<u>Current</u>	<u>1985-1990</u>
Inlet Pressure Lose ($\Delta P/P$) %	0.76	0.76
Stage Efficiency (Polytropic) %	92	93
Corrected Air Flow Per Unit Area, lb/sec/ft ²	36-38	36-40
Corrected Tip Speed ($V_T/\sqrt{\theta}$) ft/sec	1100-1200	1400-1500
Hub/Tip Ratio, Inlet/Exit	0.55/0.80	0.55/0.80
Maximum Aspect Ratio (Mean Section)	3.0	3.0
Stage Pressure Ratio at 90-93% Efficiency	1.2	1.5
Flow Coefficient (Axial/Tangential Velocity)	0.5 → 0.7	0.5 → 0.7
Work Coefficient	0.7 → 0.9	0.7 → 0.9
<u>High Compressor</u>		
Stage Efficiency (Polytropic) %	90	92
Corrected Air Flow Per Unit Area, lb/sec/ft ²	34 → 36	35 → 38
Maximum Corrected Tip Speed ($V_T/\sqrt{\theta}$) ft/sec	1000	1400
Hub/Tip Ratio, Inlet/Exit	0.80/0.90	0.80/0.94
Minimum Aspect Ratio (Mean Section)	1.0	1.0
Flow Coefficient (Axial/Tangential Velocity)	0.5 → 0.7	0.5 → 0.7
Work Coefficient	0.7 → 0.9	0.7 → 0.9
<u>Combustor</u>		
Combustion Efficiency %	100	100
Total Pressure Loss ($\Delta P/P$) %	4 → 6	3 → 5
Maximum Temperature Rise	1400	2300
Combustor Exit Temperature °F	2100	2600
<u>High Turbine</u>		
Nominal Stage Efficiency (Polytropic) %	89	92
Typical Design Stage Work, Btu/lb	160	200
Maximum Hub/Tip Ratio	.88	0.88
Blade Height/Axial Width	1.0 → 2.5	1.0 → 2.5
Taper Ratio	0.8	0.65
Minimum Blade Mean Axial Width, in.	1.0	1.0
Minimum Vane Mean Axial Width, in.	1.5	1.5
Allowable Blade Metal Temperature, °F	1550	1700
Velocity Ratio at Design	≥ 0.55	> 0.55
Vane Air Cooling Flow, % of Total Flow	8 → 10	13.5 → 15.0
Blade Air Cooling Flow % of Total Flow	2 → 4	6.5 → 7.0

TABLE II-3 (Cont'd)

TYPICAL OPEN-CYCLE GAS TURBINE DESIGN PARAMETERS

<u>Low Turbine</u>	<u>Current</u>	<u>1985-1990</u>
Nominal Polytropic Stage Efficiency	89	92
Maximum Last Stage Hub/Tip Ratio	0.75	0.75
Blade Height/Axial Width	2.0 → 6.8	2.0 → 6.8
Taper Ratio	0.8	0.65
Minimum Blade Mean Axial Width, in.	1.5	1.5
Minimum Vane Mean Axial Width, in.	1.5	1.5
Exit Diffuser Losses ($\Delta P/P$), %	1.5	1.5
Velocity Ratio at Design	≥ 0.55	≥ 0.55
<u>Power Turbine</u>		
Total Efficiency (Adiabatic), %	90	92
Last Stage Hub/Tip Ratio	0.5 → 0.6	0.5 → 0.6
Maximum Blade Length, in.	24	28
Minimum Blade Mean Axial Width, in.	1.5	1.5
Blade Mean Height/Axial Width	2.0 → 5.5	2.0 → 5.5
Taper Ratio	0.8	0.65
Velocity Ratio at Design	70.6	70.6
Maximum Allowable Blade Root Stress, psi	40,000	50,000
Exit Velocity, ft/sec	400 → 850	400 → 850
Exit Diffuser Losses ($\Delta P/P$) %	1.5	1.5

TABLE II-4

PROJECTED OPEN-CYCLE GAS TURBINE
CONTINUOUS POWER CAPABILITIES

Compressor Inlet Temperature = 59°F

ENGINE	CYCLE	YEAR AVAILABLE					
		1980		1985		1990	
		shp	sfc	shp	sfc	shp	sfc
LM 2500	Simple	25,000 ⁽¹⁾	0.39	27,000 ⁽¹⁾	0.38		
	COGAS	33,000	0.30	36,000	0.29		
FT9	Simple	35,000 ⁽¹⁾	0.39	45,000 ⁽¹⁾	0.38	50,000 ⁽²⁾	0.38
	COGAS	47,500	0.30	62,000	0.28	67,000	0.28
LM 5000	Simple	43,000	0.39	51,000 ⁽¹⁾	0.38	55,000 ⁽²⁾	0.38
	COGAS	55,000	0.30	70,000	0.28	73,000	0.28
New Boost Engine (TIT=2600°F, OPR=16)	Simple	-	-	-	-	60,000 ⁽³⁾	0.37
	COGAS	-	-	-	-	85,000	0.26
New Cruise Engine	Simple	10,000 ⁽¹⁾	0.40	10,000 ⁽²⁾	0.38	15,000 ⁽³⁾	0.37
	COGAS	12,000	0.36	13,500	0.28	21,000	0.27
SPEY Derivative	Simple	15,000	0.41	-	-	-	-
	COGAS	18,000	0.34	-	-	-	-
RB 211 Derivative	Simple	30,000	0.40	-	-	-	-
	COGAS	39,000	0.32	-	-	-	-
FT4C-3F	Simple	40,000	0.41	-	-	-	-
	COGAS	54,000	0.31	-	-	-	-
OLYMPUS	Simple	29,000	0.45	-	-	-	-
	COGAS	43,000	0.32	-	-	-	-

(1) Minimal modifications required

(2) Major modifications required

(3) Major new development effort

TABLE II-5

UTC HELIUM GAS TURBINE MILESTONES

P&WA Study of CCGT Space Power	1960's
UTRC Study of CCGT System	Aug 1963
UTRC Study of HTGR-CCGT and Contract with GA	Nov 1969
UTRC Study of CCGT-ANP	July 1971
P&WA-GA Program Initiated	Feb 1972
P&WA-GA Phase I&II	Sept 1972
UTRC Nuclear Power Study	Jan 1973
PSD-GA Phase IIIa	July 1973
UTRC Solar CCGT Study	Oct 1973
UTRC Study of Coal-Fired Fluid Bed CCGT	Jan 1974
UTRC Fusion Power Study	Jan 1975
UTRC-U of Wisconsin UWMAK-III Study	Apr 1975
UTRC Study of ONR-LWSPS-Part I	Apr 1976
European CCGT Fact Finding Trip	July 1976

TABLE II-6

CRITICAL CCGT TURBOMACHINERY DESIGN PARAMETERS

<u>Parameters</u>	<u>Ranges</u>
Mean Blade Velocity (fps)	1000 - 1200
Blade Root Stress (psi)	15,000 - 20,000
Hub/Tip Ratio	
Compressor	0.86 - 0.92
Turbine	0.75 - 0.90
Aspect Ratio	
Compressor	1.2 - 2.0
Turbine	1.2 - 3.0
Stage Loading	
Compressor	0.7 - 0.75
Turbine	2.5 - 2.7
Gap/Chord Ratio	0.4
Turbine Efficiency, %	0.90 - 0.95
Compressor Efficiency, %	0.85 - 0.90

TABLE II-7

LWSPS COMPONENT CAPABILITY LIMITATIONS

<u>Component</u>	<u>Unit Capacity,(shp)</u>	<u>No. units</u>	<u>Configuration</u>
Gas turbine			
OCGT	20,000-50,000	$\leq 4 + \text{lift}$	1 power turbine
CCGT	40,000-300,000	$\leq 4 + \text{lift}$	0, 1, or 2 power turbines
Gear box			
Offset	$< 150,000$	≤ 6	1 or 2 stages
Epicyclic	$< 100,000$	≤ 6	1 or 2 stages
Bevel	$< 60,000$	≤ 12	1 or 2 stages
Thrustor			
Fixed pitch	20,000-10,000	≤ 6	Sub. (F) and super-cavitating (\bar{F})
C.R.P.	20,000-60,000	≤ 6	Sub. (R) and super-cavitating (\bar{R})
Water jet	20,000-50,000	≤ 6	

TABLE II-8

SUMMARY OF MAJOR PARAMETRIC VALUES CONSIDERED

<u>Parameter</u>	<u>Type</u>	<u>Min.</u>	<u>Max.</u>
<u>Ships</u>			
Installed power, shp	All	40,000	300,000
Max. speed, knots	Auxiliary	20*	26
	Conventional	20*	35
	Hi-speed dest.	20*	50
	Hi-perf. ship	30*	80
	Varied	2	50
Cruise power, %	Varied	10	40
Payload fraction, %	Varied	10	500
Endurance @ cruise, hrs	Varied	30	60
Structure weight fraction, %	All	30	60
<u>Engine</u>			
Unit size, shp	CCGT	10,000	50,000
	CCGT	40,000	200,000 ⁺
Shaft speed, rpm	CCGT	3,000	5,400
	CCGT	3,200	6,200
Turbine inlet temp, °F	CCGT	2,000	2,600
	CCGT	1,400	1,800
Comp. press. ratio	CCGT	12	40
	CCGT	1.75	6
Inlet pressure, psi	CCGT	14.0	14.7
	CCGT	600	1,000
Inlet temp, °F	CCGT	59°	80°
	CCGT	1,500	1,800
Cycle press. loss, %	CCGT	6	14
<u>Heat Exchangers</u>			
Effectiveness, %	CCGT-Regen	70	9
Metal temp, °F	CCGT-Regen	--	1, 00
Cooling water inlet, °F	Sea/Fresh	80	120
Pitch/diameter ratio	All	1.3	1.6
<u>Heat Sources</u>			
Heater spec. wt., lb/shp	CCGT	4	12
Reactor spec. wt., lb/shp	CCFT	10	20
Metal temperature, °F	CCGT		1,800

TABLE II-8 (Cont'd)

SUMMARY OF MAJOR PARAMETRIC VALUES CONSIDERED

<u>Parameter</u>	<u>Type</u>	<u>Min.</u>	<u>Max.</u>
<u>Gearbox</u>			
Unit size, shp	Offset	20,000	150,000
	Epicyclic	20,000	100,000
	Bevel	20,000	60,000
K factor, lb/im/in	Conventional	--	300
	Hi-speed	--	400
	Lift	--	500
Tooth load/inch, lb/in	All	--	3,500
Tip speed, ft/min	All	--	25,000
<u>Shafts</u>			
Shear stress, lb/in ²	Hollow	6,000	12,000
Shaft speed, rpm	All	105	
Inner/outer diameter ratio	Hollow	0.60	0.70
<u>Thrustor</u>			
Unit size, shp	F.P. Prop	20,000	100,000
	C.R.P.	20,000	60,000
	Wat. Jet	20,000	50,000
Shaft speed, rpm	Subcav	105	320
	Supercav	480	980
	Wat. Jet	800	1,600
Efficiency, %	Various	45	75

* Cruise speed

+150,000 shp maximum output per shaft

REQUIREMENTS FOR CRUISE POWER

SHIP CATEGORY	WEIGHT (LONG TONS)	V_{MAX}/V_{CRUISE} (KNOTS)
Ia DESTROYERS	3,000-9,000	35/20
Ib 50 KNOTS DESTROYER	3,000-6,000	50/20
II CRUISERS	9,000-25,000	35/20
III CARRIERS	40,000-100,000	35/20
IV SES	2,000-4,000	80/30
V AUXILIARY	30,000-100,000	26/20

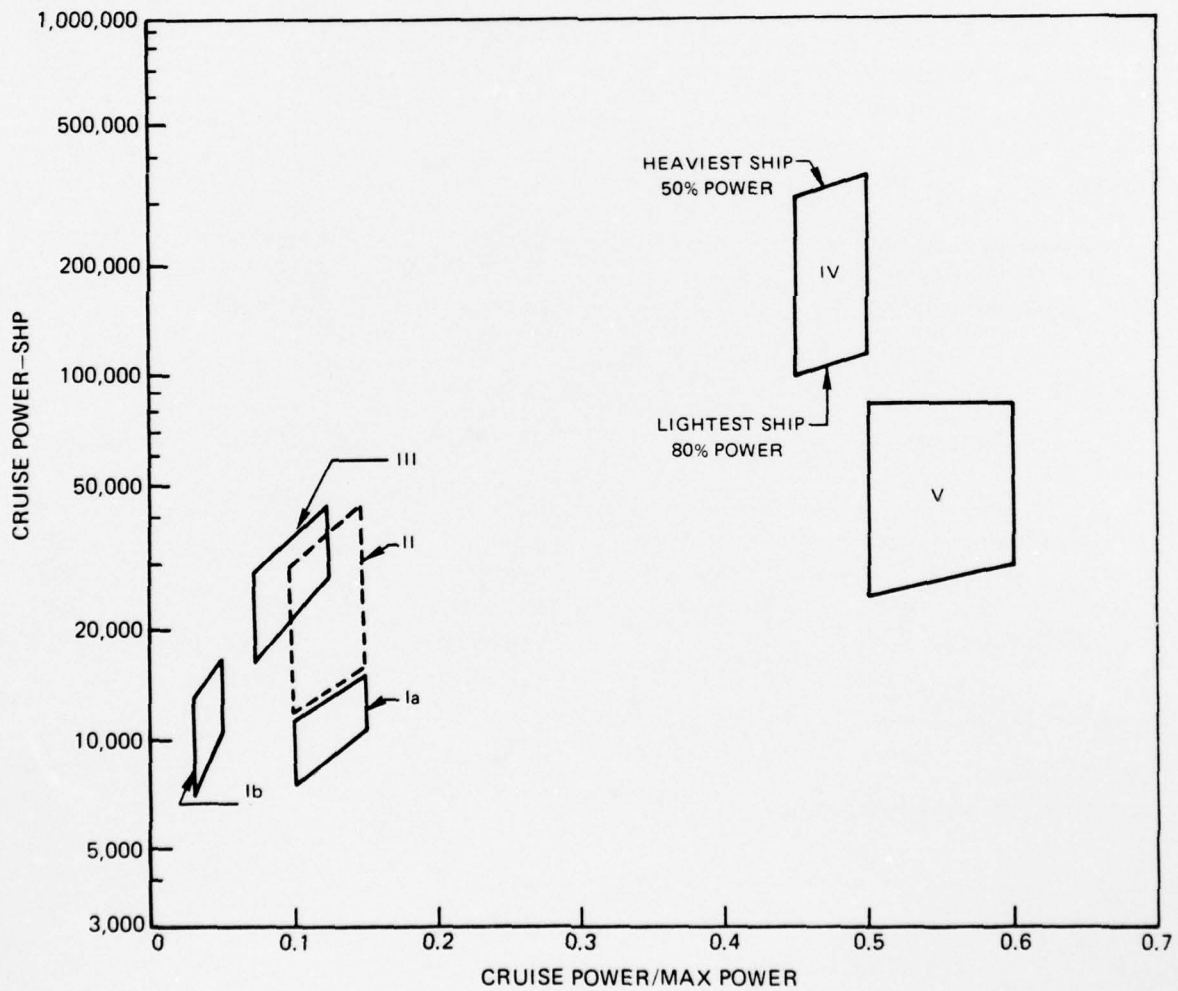

VEHICLE WEIGHT SUBDIVISION

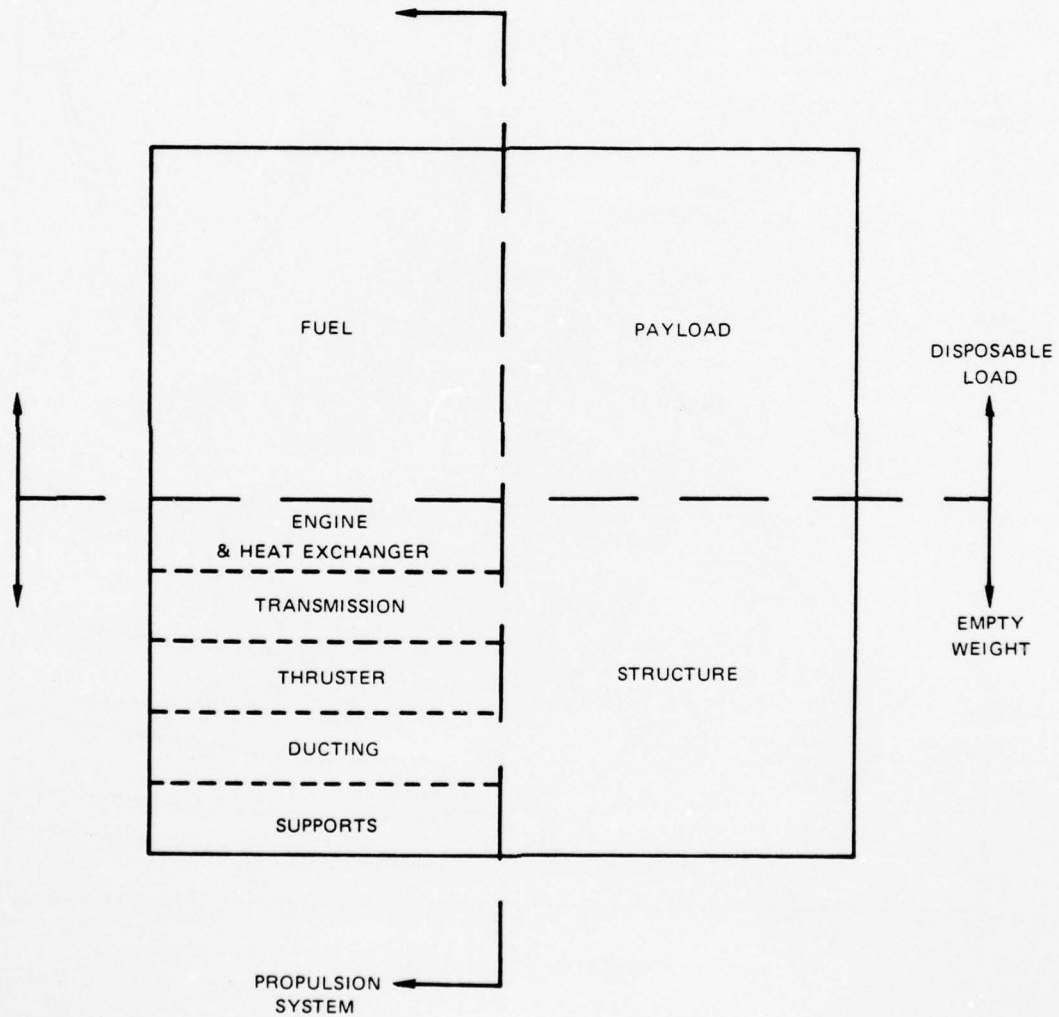

TYPICAL OPEN-CYCLE GAS TURBINE AND PROPELLER SPEED MATCH

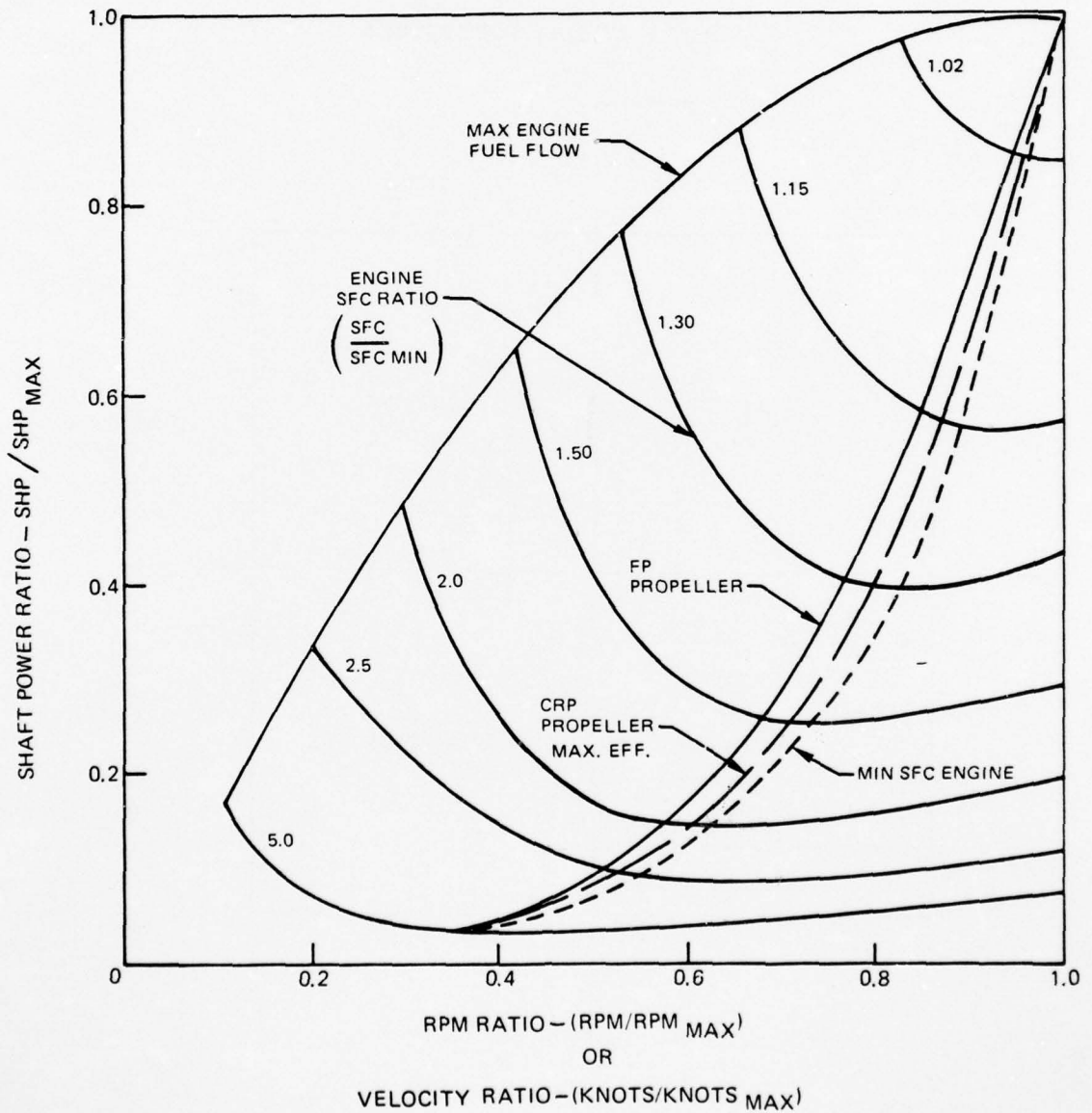

TYPICAL PROPULSION SYSTEM ARRANGEMENTS

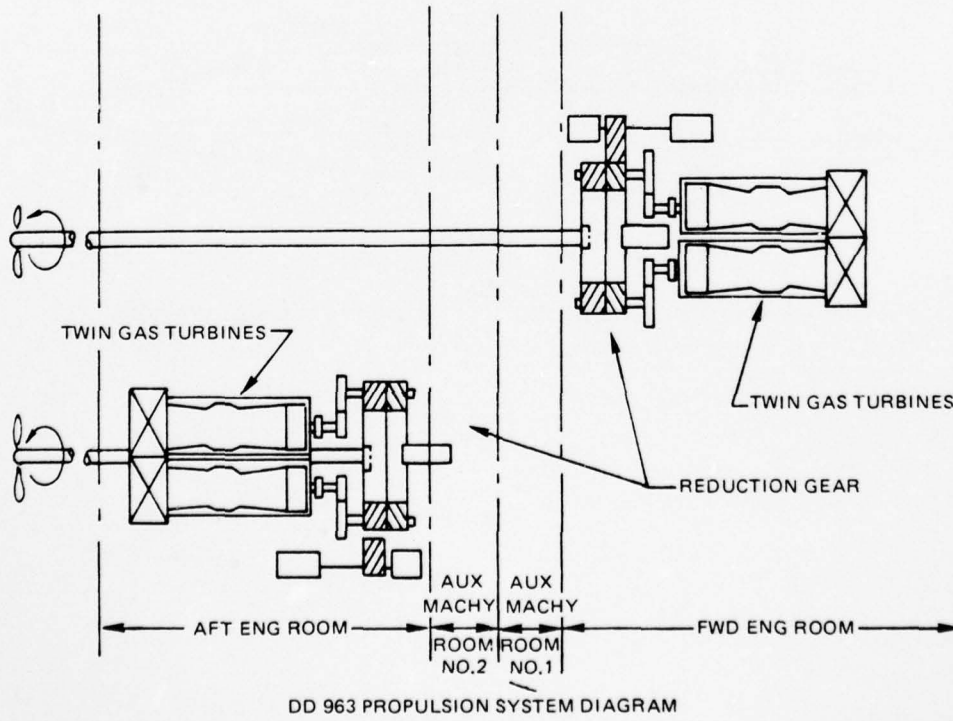
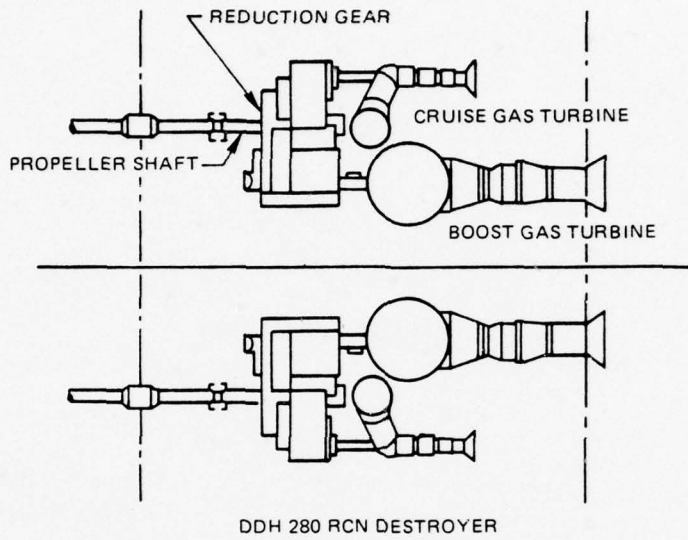

DD963 MACHINERY LAYOUT

GT = GAS TURBINE
RG = REDUCTION GEAR

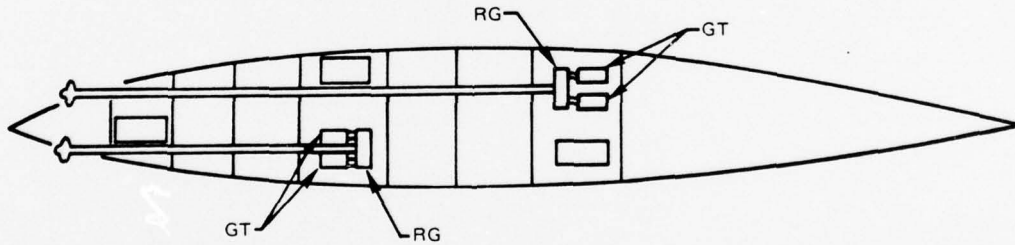

3 BULKHEADS BETWEEN ENGINE ROOMS FOR VULNERABILITY CONSIDERATIONS

ADVANCES IN TURBINE MATERIALS

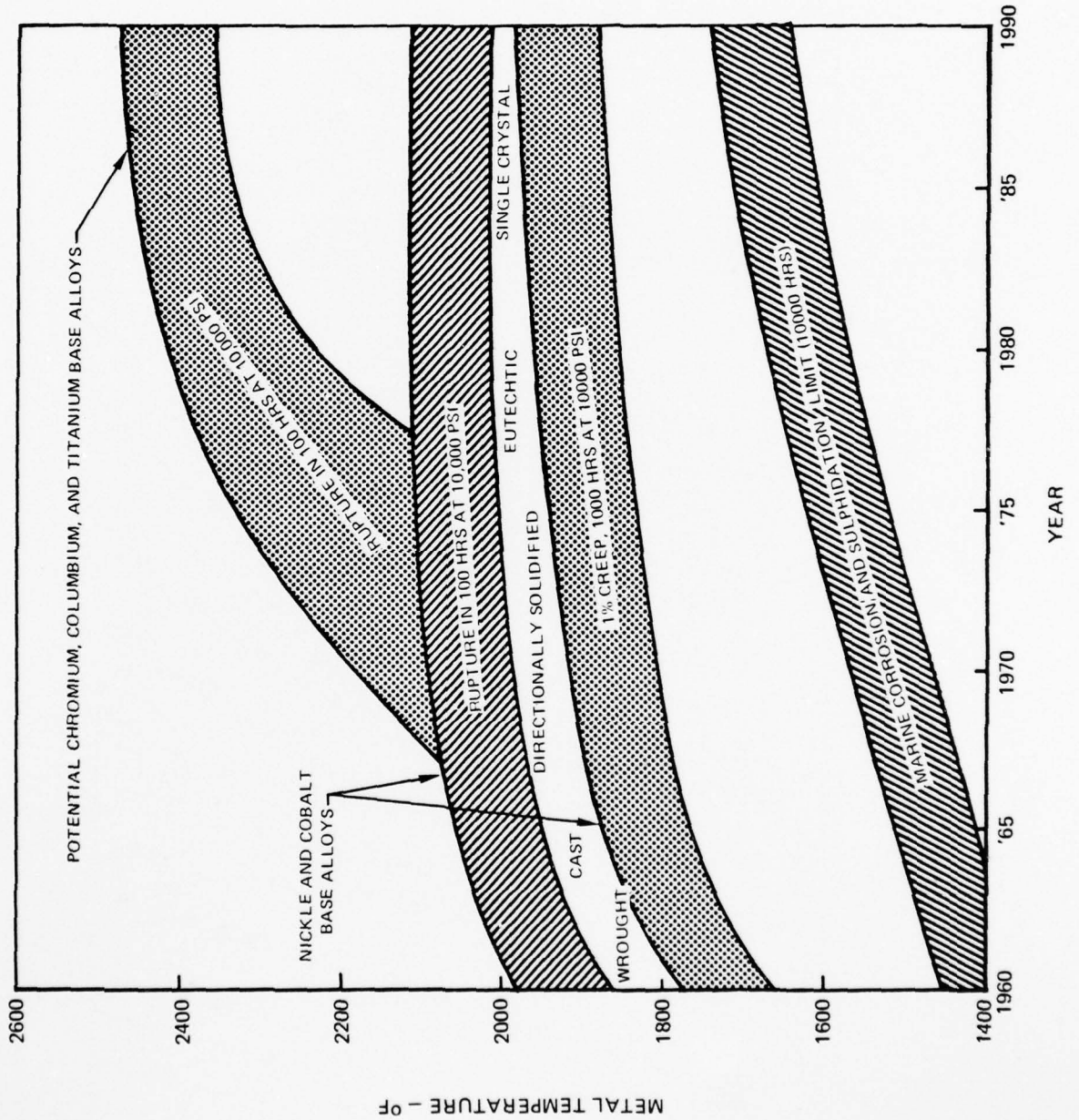

COOLING AIR BYPASS FLOW REQUIREMENTS FOR OPEN-CYCLE GAS TURBINES

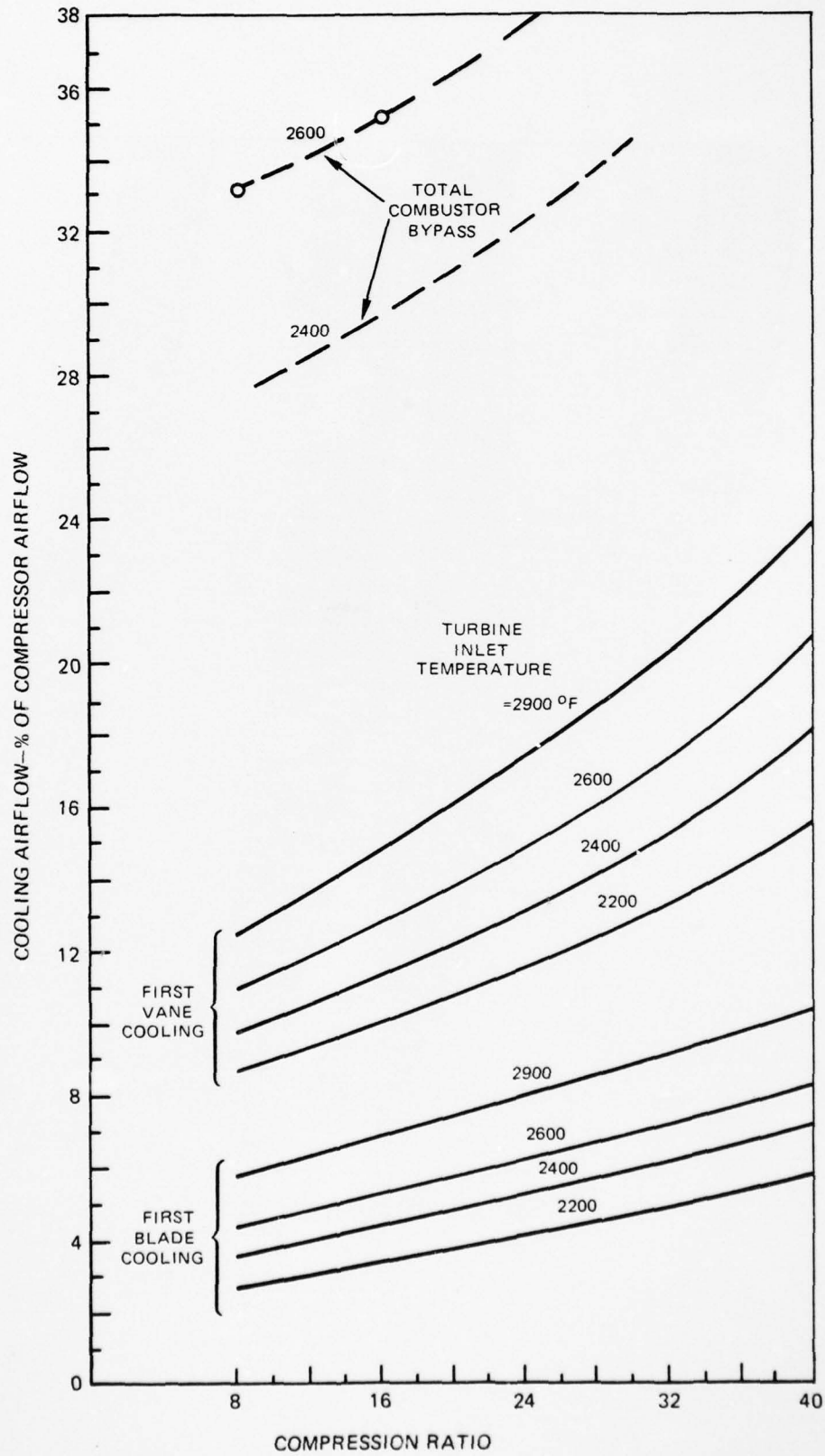

AD-A040 032

UNITED TECHNOLOGIES RESEARCH CENTER EAST HARTFORD CONN F/G 21/5
LIGHTWEIGHT PROPULSION SYSTEMS FOR ADVANCED NAVAL SHIP APPLICAT--ETC(U)
MAY 77 S C KUO

N00014-76-C-0542

NL

UNCLASSIFIED

UTRC/R77-952566-5

2 OF 3

AD
A040032

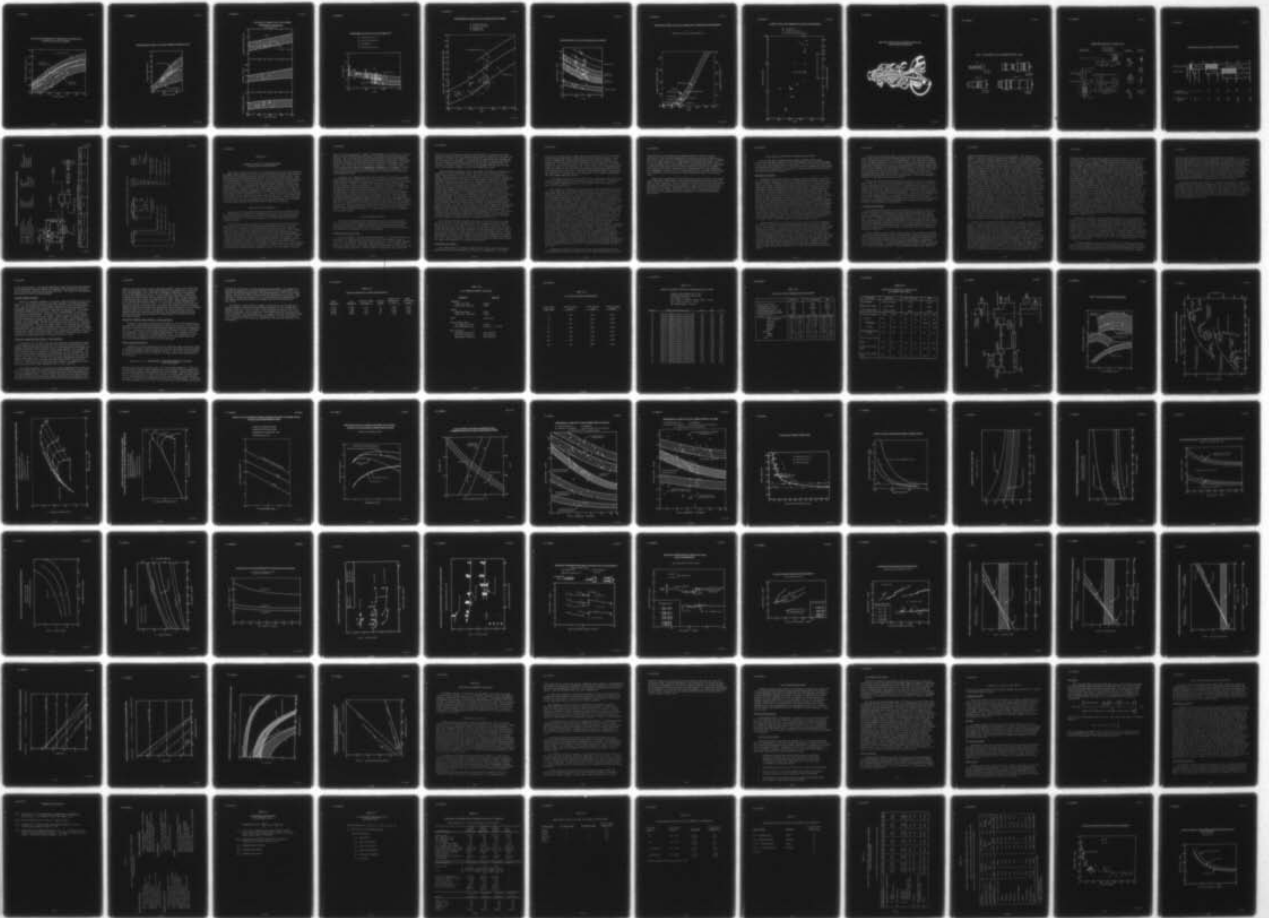

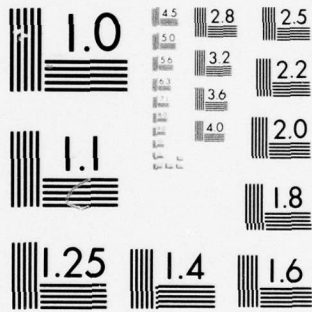

MICROCOPY RESOLUTION TEST CHART
NATIONAL BUREAU OF STANDARDS-1963-A

ESTIMATED PROGRESSION OF TURBINE INLET TEMPERATURE FOR OPEN-CYCLE GAS TURBINES

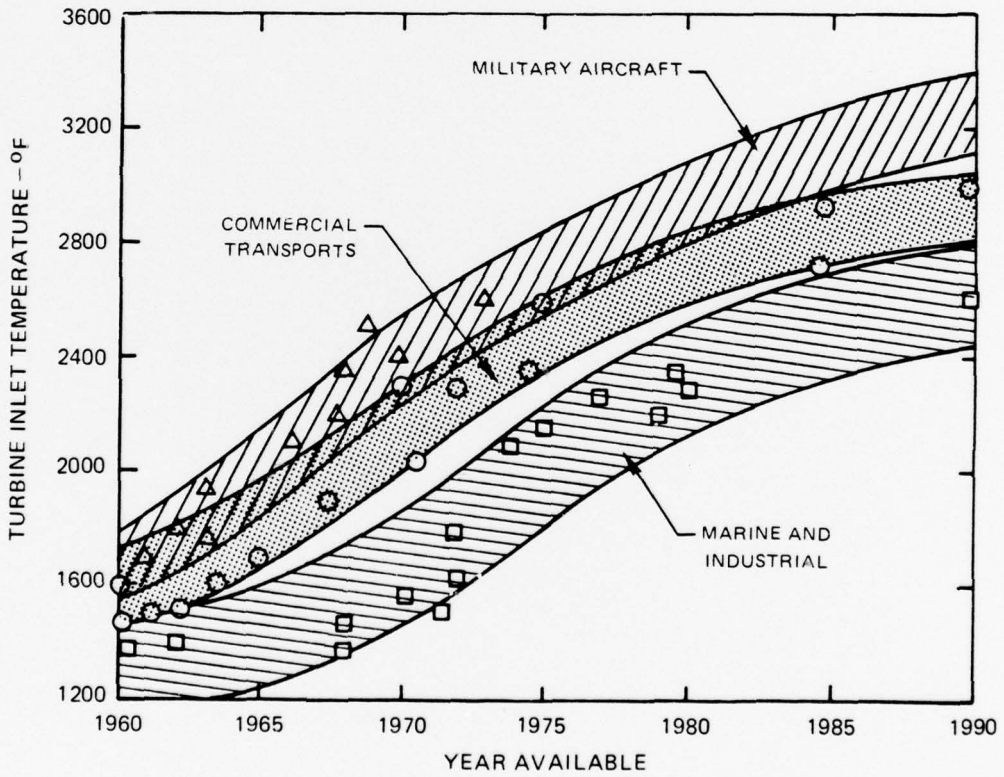

PROGRESSION OF OPEN - CYCLE GAS TURBINE PRESSURE RATIO

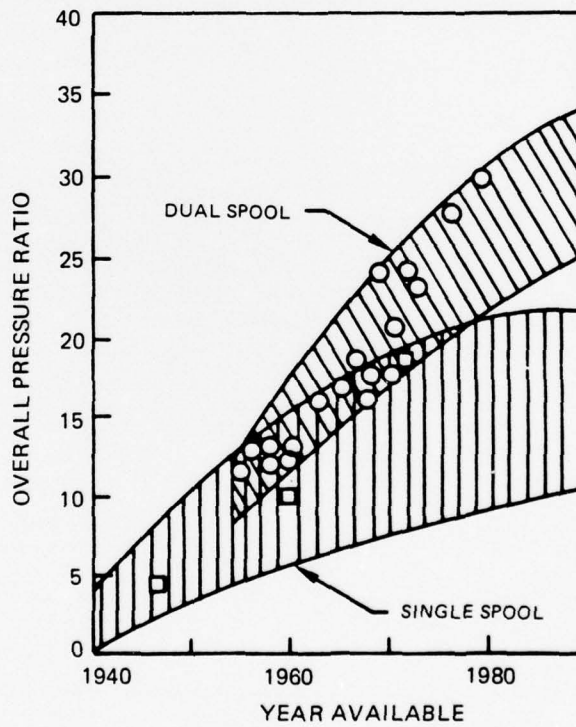

ADVANCES IN OPEN-CYCLE GAS TURBINE COMPRESSOR PERFORMANCE

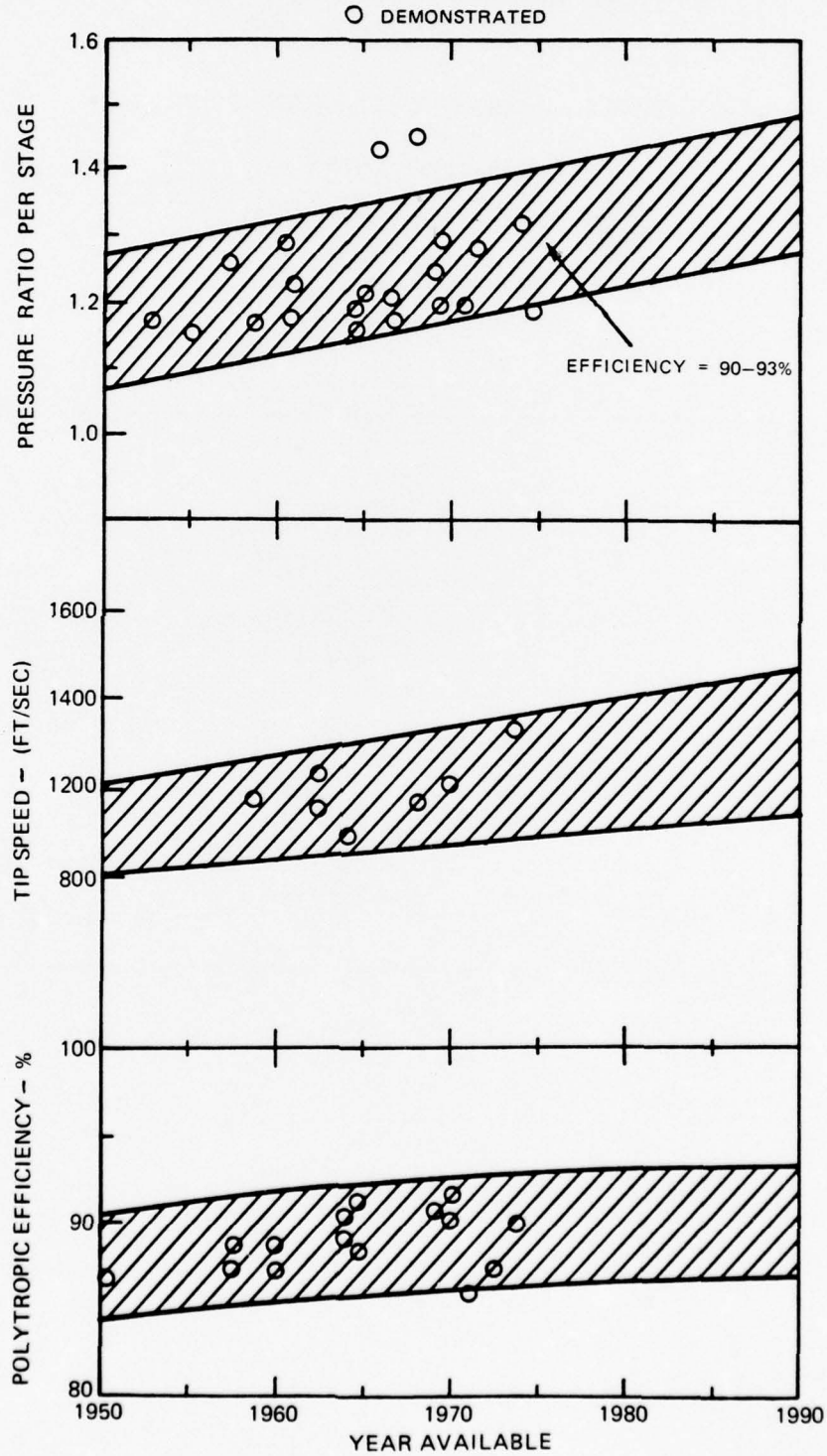

PROGRESSION OF OPEN-CYCLE GAS TURBINE SFC

- △ AIRCRAFT DERIVATIVE
- INDUSTRIAL DERIVATIVE
- REGENERATIVE
- ▽ COMBINED CYCLE (COGAS)

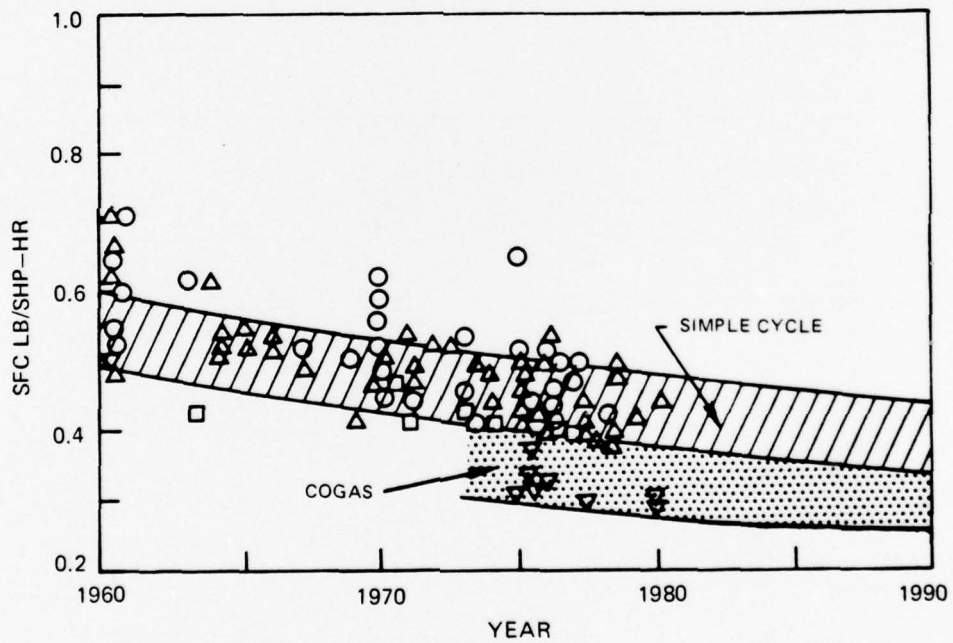

PROGRESSION OF OPEN-CYCLE GAS TURBINE SPECIFIC POWER

- △ AIRCRAFT DERIVATIVE
- D INDUSTRIAL DERIVATIVE
- REGENERATIVE
- COMBINED CYCLE

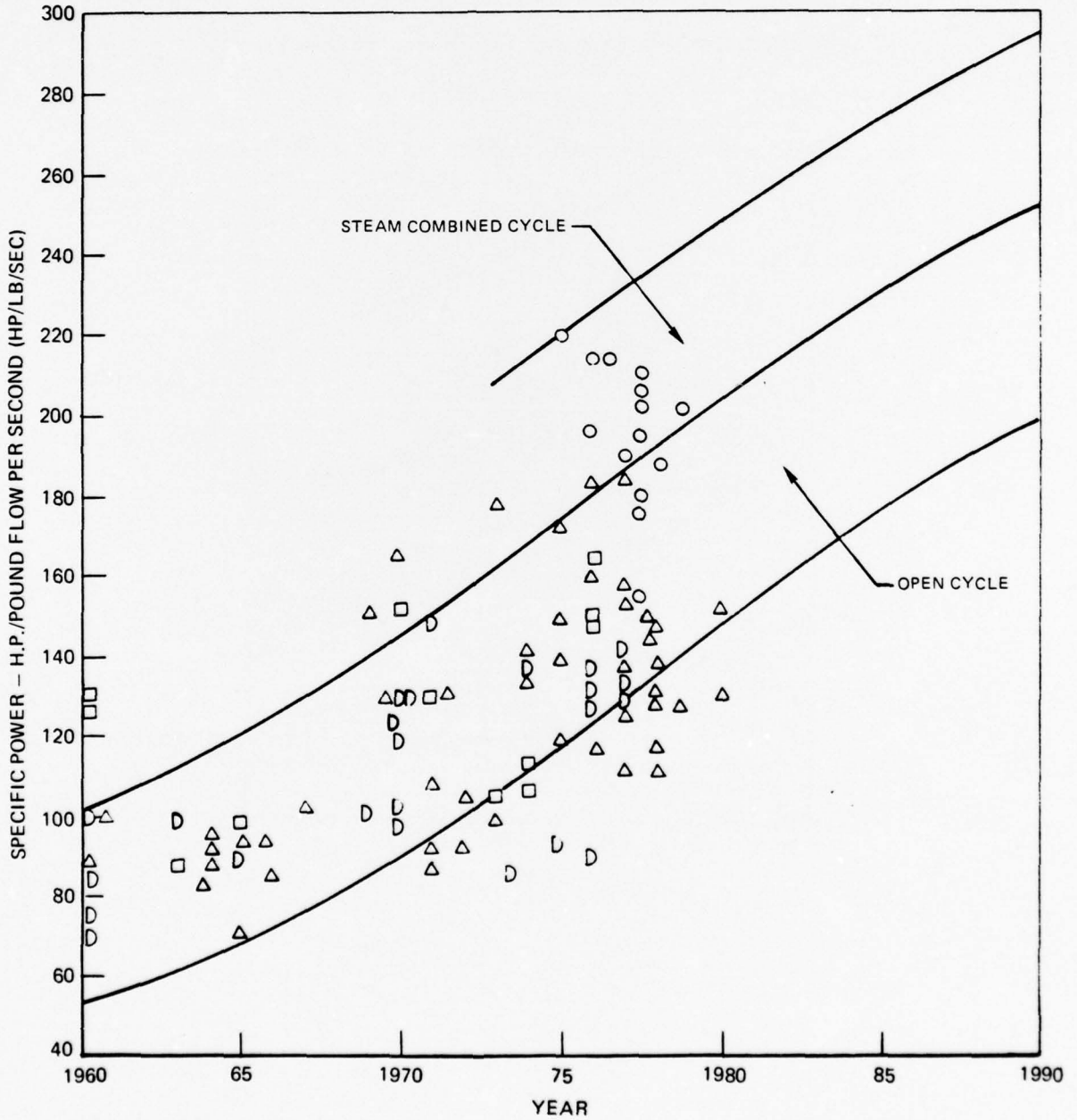

TRENDS IN OPEN-CYCLE GAS TURBINE SPECIFIC WEIGHT

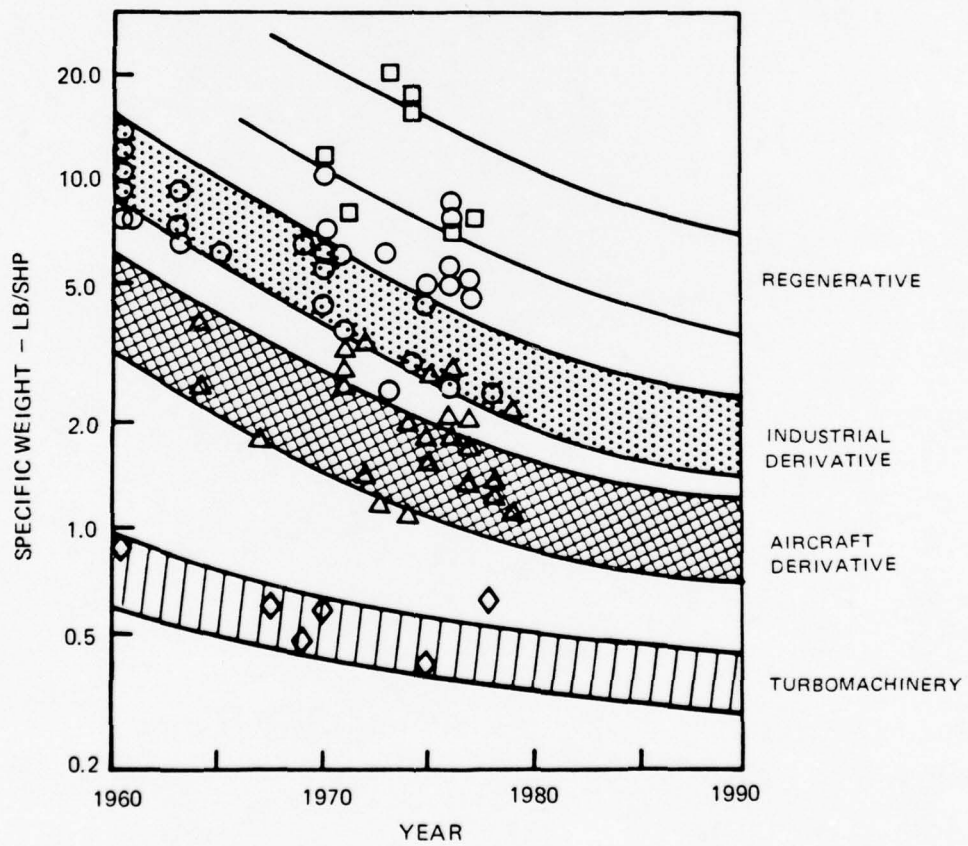

ESTIMATED CLOSED-CYCLE GAS TURBINE INLET TEMPERATURE PROGRESSION

● EXISTING CLOSED-CYCLE GAS TURBINE PLANT

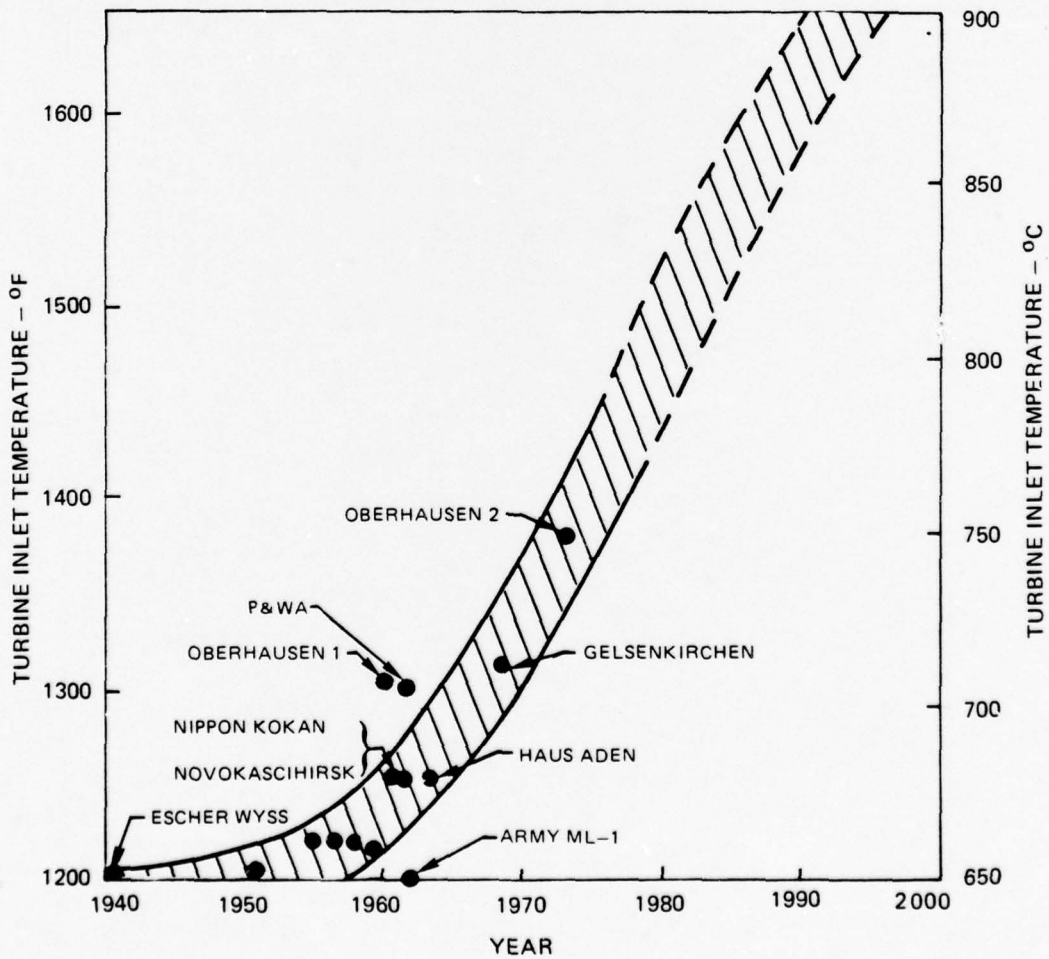

CLOSED-CYCLE GAS TURBINE UNIT CAPACITY PROGRESSION

- IN OPERATION
- ⊗ CONCEPTUAL DESIGN, UTC
- ◇ CONCEPTUAL DESIGN ELSEWHERE

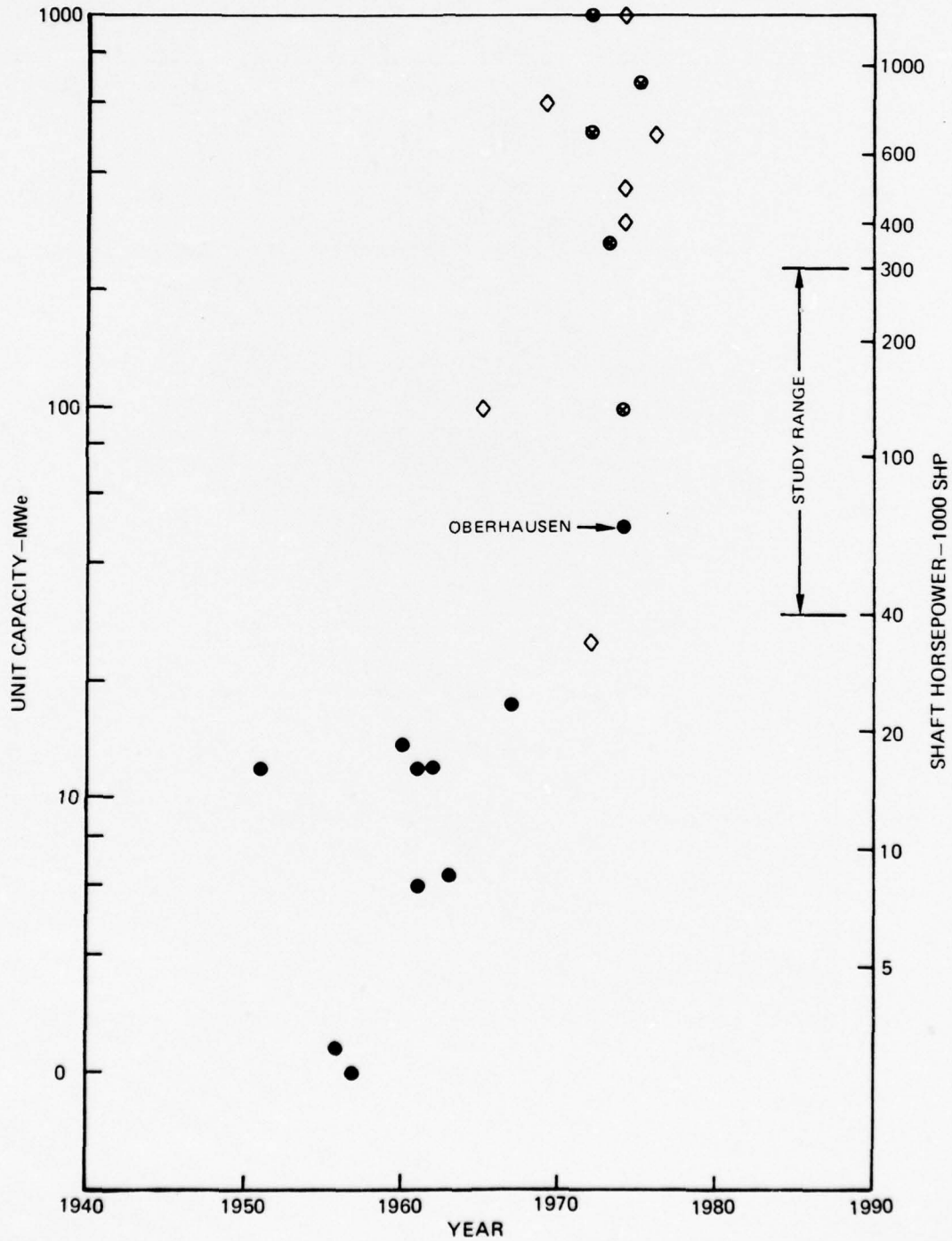

BRAYTON CLOSED-CYCLE TURBOMACHINERY FOR
SPACE POWER APPLICATION

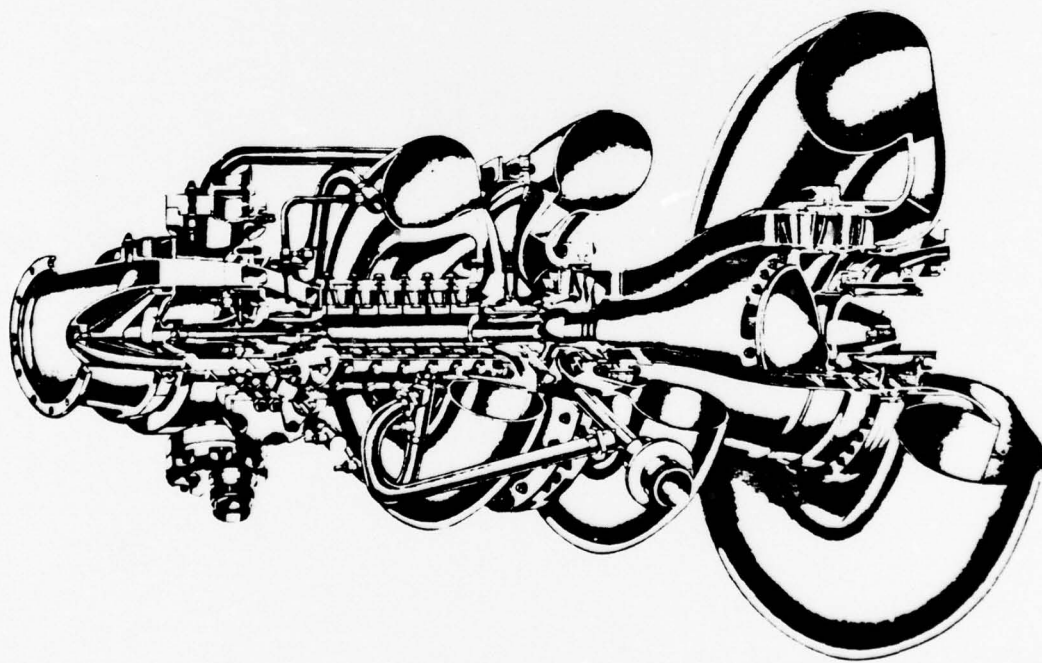

OPEN- AND CLOSED-CYCLE TURBOMACHINERY SIZES

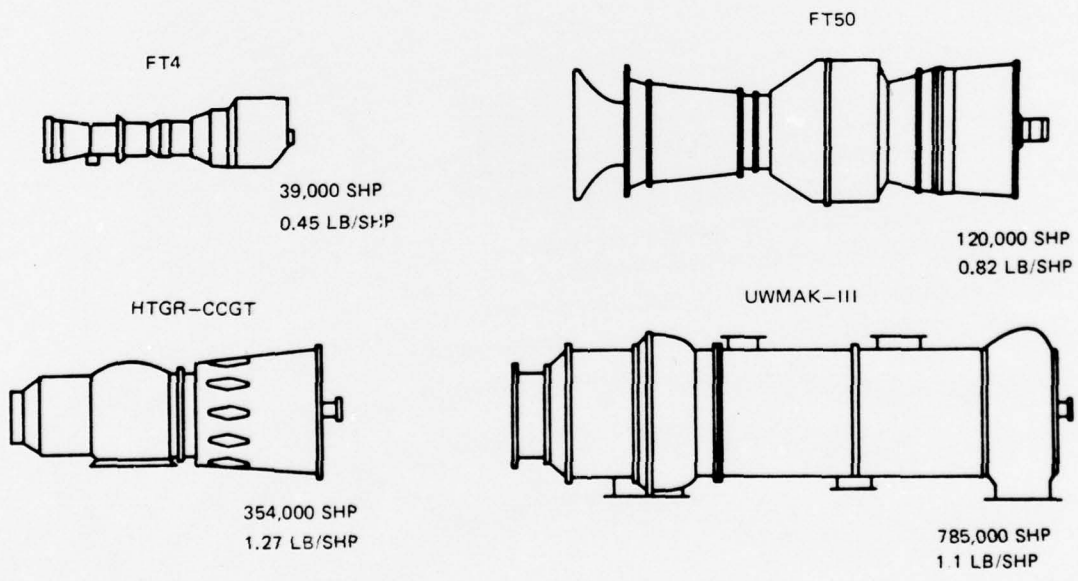

LWSPS CONFIGURATION ALTERNATIVES

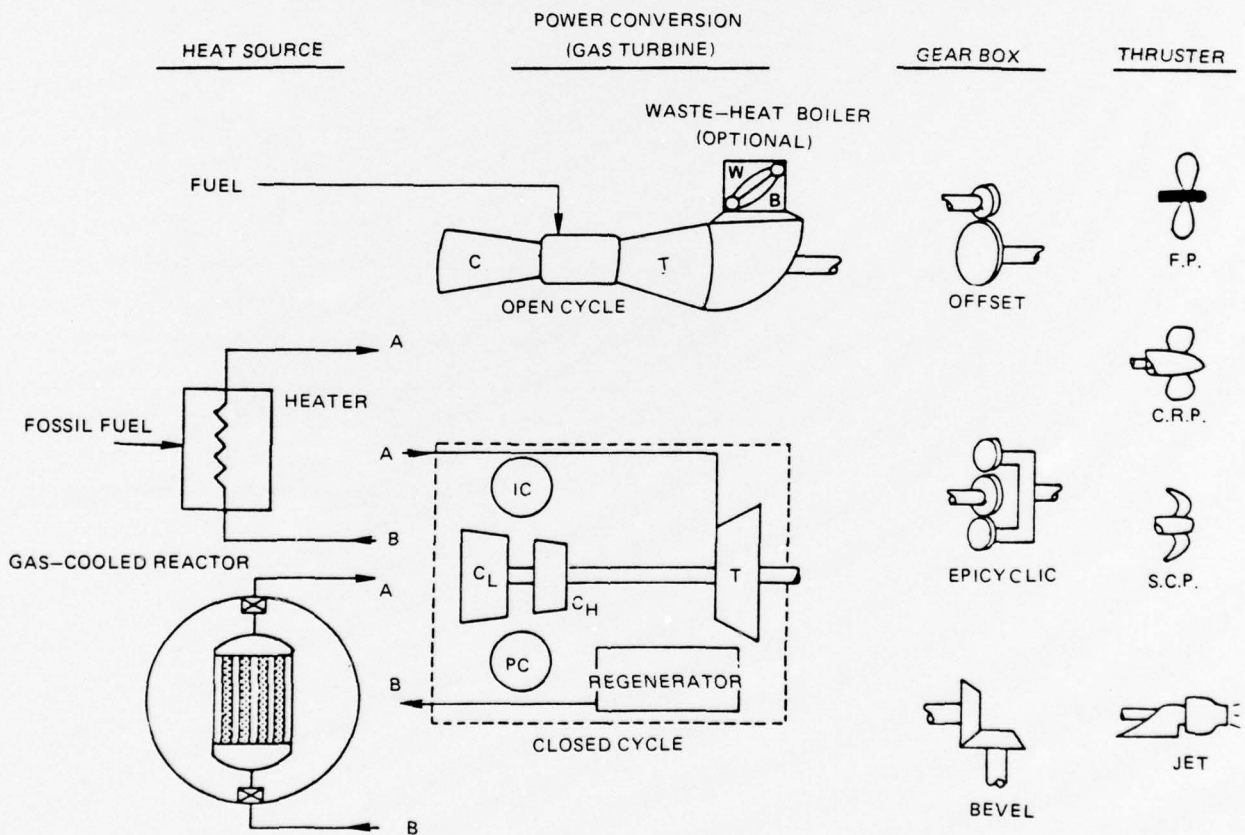



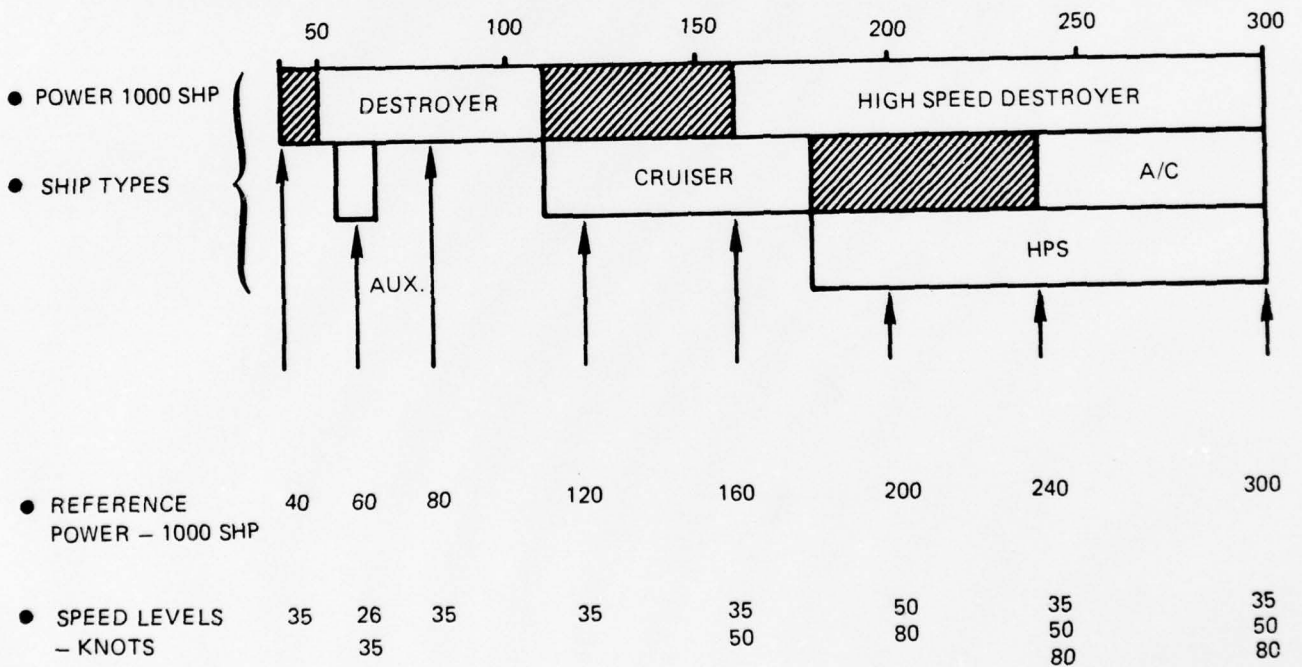

REFERENCE INSTALLED POWER LEVELS SELECTED FOR LWSPS

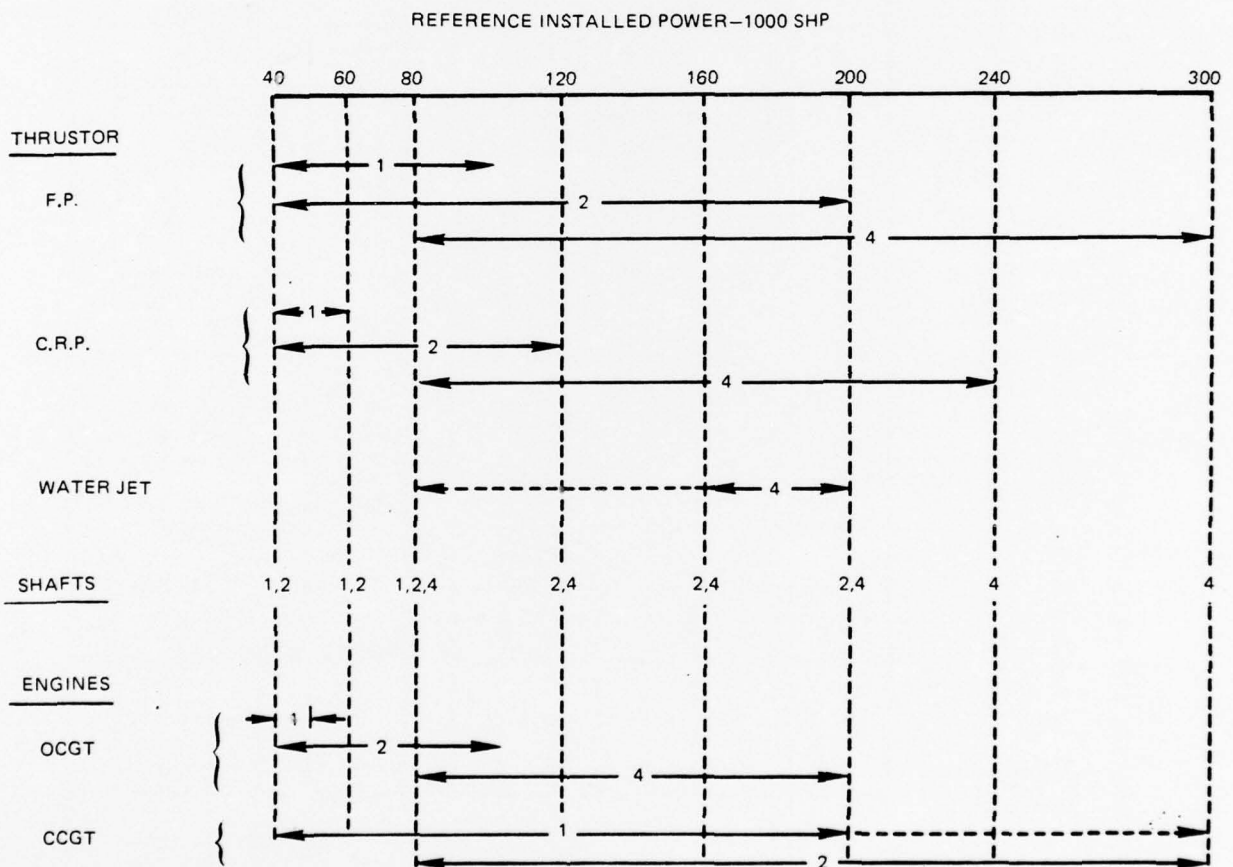





THRUSTOR, SHAFTS, AND ENGINE REQUIRED FOR LWSPS



BASIC ARRANGEMENTS AND SELECTION MATRIX FOR LIGHTWEIGHT SHIP PROPULSION SYSTEMS

-  ENGINE LIMITATIONS
-  THRUSTOR LIMITATION
-  GEAR BOX LIMITATION
-  COMPATIBLE/LESS ATTRACTIVE
-  APPLICABLE THRUSTERS

BASIC ARRANGEMENTS	SHP	40K		60K		80K		120K		160K		200K		240K		300K		
		O	C	O	C	O	C	O	C	O	C	O	C	O	C	O	C	
A  110 &€	1 UNIT			Y		Y		Y		Y		Y		Y		Y		
	2																	
	4																	
B  110 &€	1	FR	FR	FR	FR	F		FR		FR		FR		FR		FR		
	2	FR	FR	FR	FR	FR	FR	FR	FR	FR	FR	FR	FR	FR	FR	FR	FR	FR
	4																	
C  120	1	FR	Y	FR	FR	FR	FR	FR	FR	FR	FR	FR	FR	FR	FR	FR	FR	
	2																	
	4																	
D  110 &€	1		Y	FR	FR	FR	FR	FR	FR	FR	FR	FR	FR	FR	FR	FR	FR	
	2																	
	4																	
E  210	1	FR		FR	FR	F	Y	FR		FR		FR		FR		FR		
	2																	
	4																	

PROPULSION SYSTEM ENERGY FLOW AND CRITICAL PARAMETERS

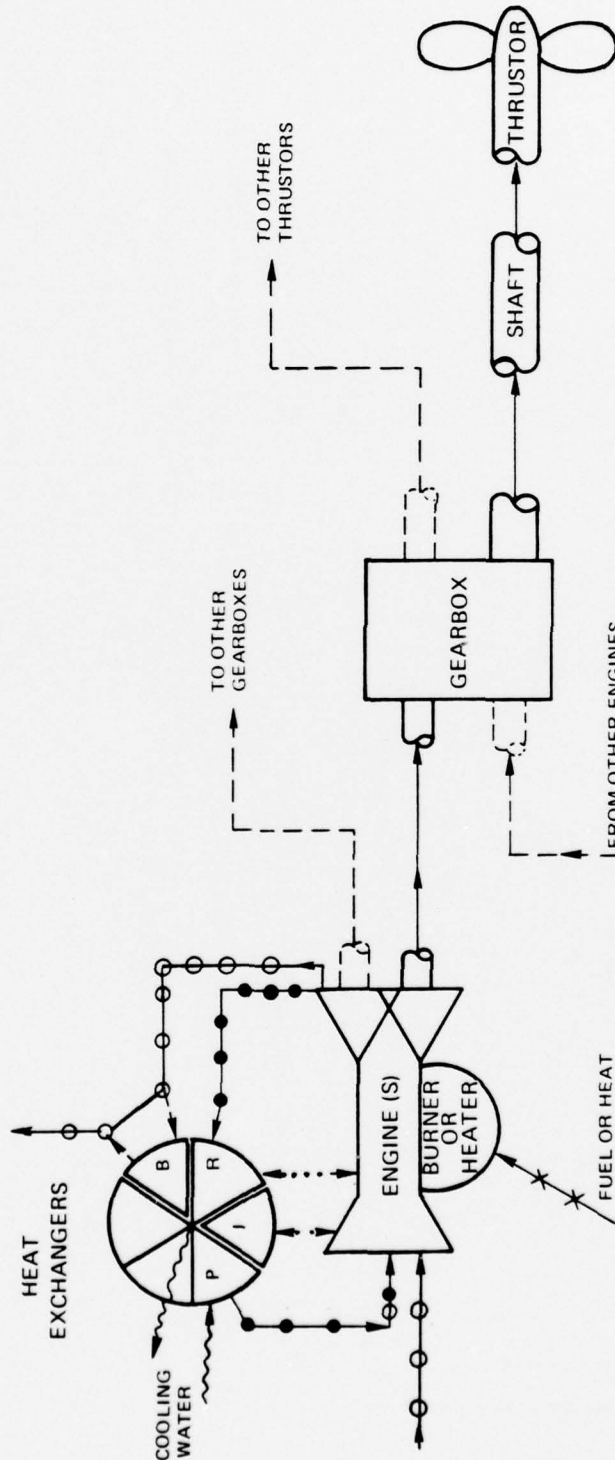
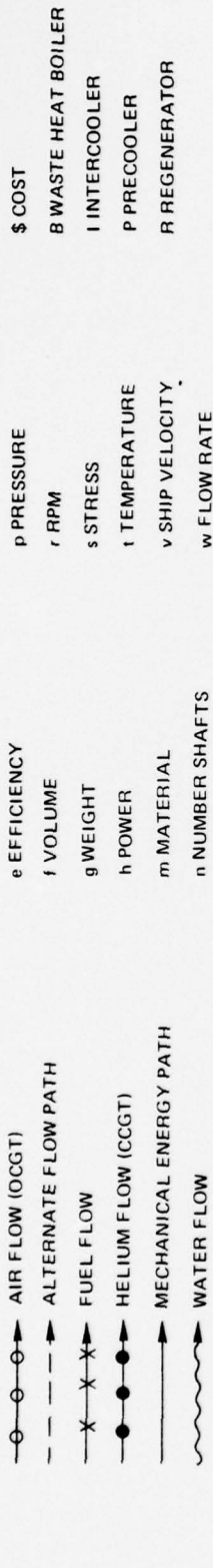

CRITICAL PARAMETERS CONSIDERED

HEAT EXCHANGERS	ENGINE	BURNER/HEATER	GEARBOX	SHAFT	THRUSTOR
f, m, p, s, t, w, \$	h, m, n, p, r, s, t, w, \$	e, g, p, t, \$	h, n, r, s,	h, n, r, s	h, n, r, v,

LIGHTWEIGHT SHIP PROPULSION SYSTEM IDENTIFICATION CODE

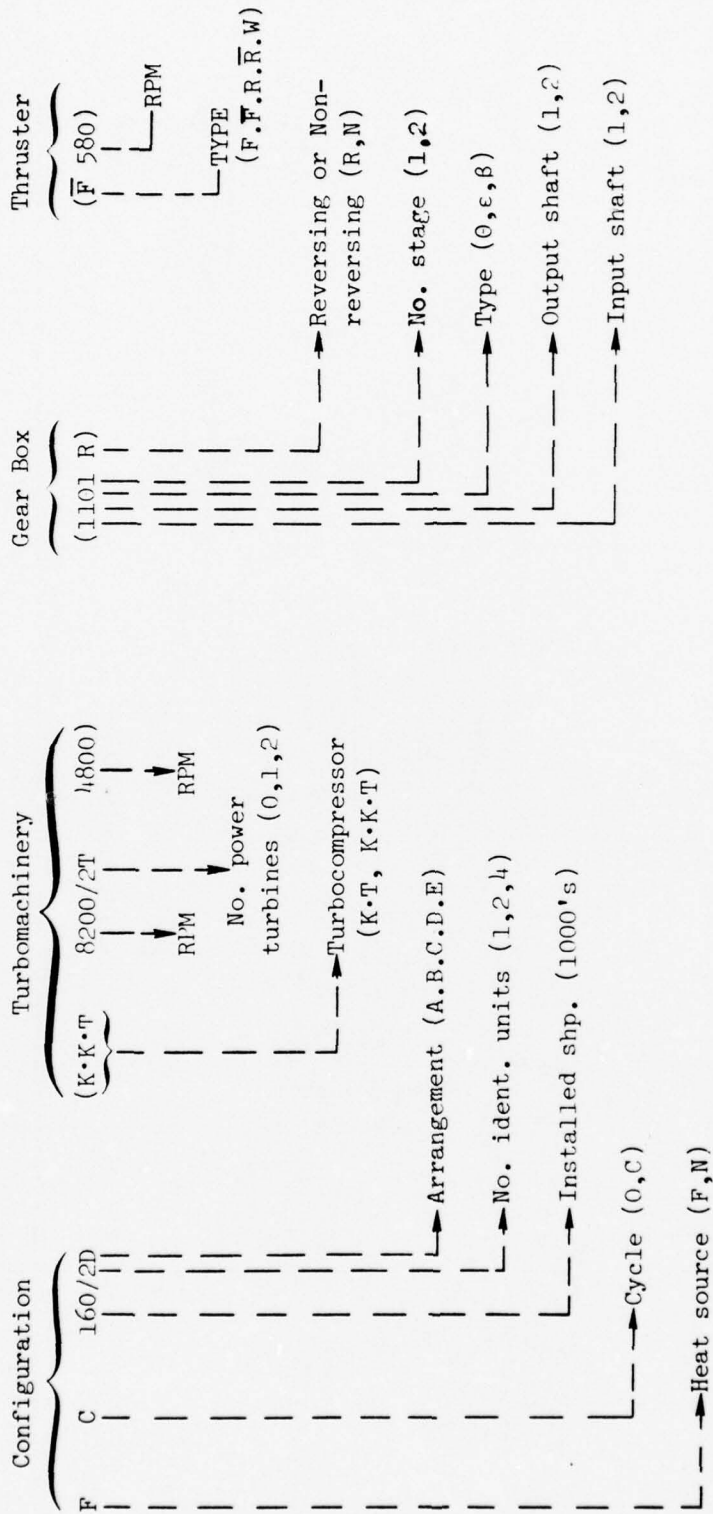

SECTION III

PARAMETRIC ANALYSIS OF SYSTEM PERFORMANCE,
SIZE AND WEIGHT CHARACTERISTICS

This section contains the results of an investigation to evaluate the performance and weight characteristics of open- and closed-cycle gas-turbines and their potential application as lightweight propulsion systems for future Navy capital ships. Parametric performance calculations were made for various cycle configurations in order to select baseline cycle configurations which could be identified as being promising for further analyses. Critical technologies and design limitations identified in Section II were used to investigate the propulsion engine component size and weight characteristics. The results were then combined with other propulsion system component weights to compute the total propulsion system weight for over 400 cases of practical propulsion system arrangements of different installed power, as identified in the selection matrix presented in Section II. Propulsion system-plus-fuel weight was estimated for the selected ship types, based on ship duty cycle and assumed heat source weight for the CCGT, as a function of the ship endurance. Payload characteristics were analyzed, and the maximum allowable heat source weights for the closed-cycle gas turbine systems were then predicted by sensitivity analyses.

Baseline Cycle Configurations

Baseline cycle configurations were selected from a number of candidate cycles by comparing the capability and/or compatibility for each of the open- and closed-cycle configurations to satisfy a set of specific propulsion system requirements derived from Table II-1 with reference given to the future technological advances projected earlier.

The open-cycle concepts considered for the preliminary screening included the base simple cycle as well as those with supercharging, precooling of inlet air, intercooling of compressor air, regenerating the combustor inlet air, reheating before the power turbine, and combined-cycle with waste heat steam turbine. Preliminary results indicated that based on the gas turbine inlet temperature, pressure ratio, and unit capacity values projected to become available in the 1985-1990 period, a simple, open-cycle gas turbine can attain design fuel use (0.38 lb/shp-hr) close to that of many diesels while providing unmatched simplicity of operation, control, response, and specific weight. A combined gas turbine and steam turbine cycle (COGAS) matched with a waste heat boiler might allow design fuel use (< 0.30 lb/shp-hr) to equal any type engine that would be available in 1990. The cost for this achievement would be an increased system complexity, capital cost, and weight, as well as

extra control and maintenance. However, these problems can be balanced to a certain extent by credit taken for providing some of the required steam for nonpropulsion purposes. The other open-cycle concepts mentioned would require added complexity and weight which could overshadow their modest performance improvement to be competitive with the simple cycle or COGAS system as a practical lightweight propulsion system in the 1990's, and therefore, were not evaluated in the present study. In the current study emphasizing lightweight, reliability, and low cost, the simple cycle incorporating advanced aircraft-derivative technologies and possible cost reduction features was selected as the baseline cycle configuration for the open-cycle propulsion system.

Utilization of a compatibility matrix for screening of closed-cycle configurations indicated that a regenerated cycle with one intercooling but no reheat would appear generally promising for integration with either a fossil heater or an advanced nuclear reactor. However, a nonintercooled closed-cycle with bottoming steam cycle also seemed to offer some potential. A simplified configuration diagram for the baseline closed-cycle gas turbine system is shown in Fig. III-1. It should be mentioned that the tradeoff between the improved thermal efficiency and the increased specific weight and volume resulting from intercooling, various degrees of regeneration, and possible waste heat recovery must be given careful analyses. It should be pointed out that for equal heat transfer, helium closed-cycle heat exchangers would be significantly smaller than their open-cycle counterparts due to the fact that helium pressure throughout the cycle is much higher (at 500 to 1000 psi) than that in a typical air cycle (at below 400 psi), that helium has a much higher specific heat than air, and that helium has much better heat transfer characteristics than does air. These characteristics could make a closed-cycle marine propulsion system less burdensome when compared to those associated with open-cycle system at the same power ratings.

Cycle Performance Analysis

The following paragraphs contain discussions of cycle performance analyses made for open-cycle and closed-cycle helium gas turbine power conversion systems. The general requirements, component constraints, critical parameters, and gas turbine technologies discussed in Sections II and III thus far provided background and guidelines in conducting this part of the analyses.

Open-Cycle Gas Turbine (OCGT)

A survey was made of the performance characteristics of several OCGT cycle configurations as indicated previously, and the results are compared as shown in Fig. III-2. The inlet-air-cooled configuration was ruled out from further consideration due to its increased complexity, size, and weight. As can be seen in this figure, the regenerative cycle offers a significant improvement in efficiency at overall pressure ratios below 10:1. However, such a configuration tends to be quite

heavy, since it would require significant modifications of lightweight aircraft-derivative engines as well as increased engine specific volume due to the lower gas pressure. Of course, the large size and weight of a gas-to-gas heat exchanger is also detrimental to lightweight. Combining intercooling of compressor gas between the low and high spools with regeneration after the high compressor offers the potential of further increases in efficiency and optimum cycle pressure but adds still more complexity, weight, and size to the propulsion system.

Only the simple, open-cycle, and to some extent, the COGAS-cycle engines were considered in the system analysis study. The COGAS cycle offers potential as being a very efficient (0.27 sfc) cruise engine of 13,000 to 21,000 shp while a simple, open-cycle engine of 20,000 to 60,000 shp could provide compact, lightweight, and fairly efficient (0.38 sfc) power as a boost engine. Typically, a projected mid-1980's air-cooled gas turbine with 16:1 pressure ratio and 2600°F TIT must bypass the combustor with 35 percent of the compressor flow for blade and vane cooling, and for the secondary flow requirements for combustor cooling (see Fig. II-7). Figure III-3 presents a more detailed look at the effect of cycle pressure ratio, turbine inlet temperature, and turbine cooling requirements of efficiency and specific power (shp/lb/sec). In a comparison between a simple-cycle air-cooled engine operating at 2600°F and one operating at the same temperature with no cooling it can be seen that the cooling air requirements severely limit both efficiency and specific power. In Fig. III-3 it can be seen that the cycle efficiency and specific power reach their respective maximum values at different pressure ratios. At the limiting turbine inlet temperature of 2600°F, the optimum pressure ratio appears to be 16:1 for COGAS, while a pressure ratio of 20:1 should be an appropriate maximum for simple cycles. Two current engines, the FT9 and LM2500 both have 16:1 pressure ratios, and these could produce 63,000 and 37,000 shp, respectively, as COGAS units with modified air-cooled turbines operating at 2600°F TIT. The results of recent studies conducted at UTRC which considered systems utilizing high pressures and water cooled vanes indicate that further increases in cycle efficiency and specific power are possible; this is also shown in Fig. III-3.

It should be noted that combined cycles could be used most effectively when applied to 10,000 to 15,000 shp simple-cycle cruise engines, producing 13,000 to 21,000 shp with sfc in the range of 0.36 to 0.27. A recent study by the Pratt & Whitney Aircraft Group indicates that an sfc of 0.36 could be attained by a COGAS system which consists of selected components from existing engines, while an sfc of 0.27 could be attained by a highly modified or entirely new engine design. COGAS systems based on engines of these smaller sizes also require relatively small steam power system but can drastically improve the cruising fuel consumption as shown in Fig. III-4. Since the majority of naval ship duty is spent at speeds near cruising, the overall fuel usage would be improved substantially.

Closed-Cycle Gas Turbine

The State-of-the-Art Performance Program (SOAPP) computer model described in Appendix E has been used extensively in this part of the analysis. For a given

turbine inlet temperature, the thermal efficiency and specific work of a CCGT power system depends on many factors, among which are such as system complexity (intercooling, regeneration, and reheating), pressure ratio, and total pressure loss. Whereas the selection of power cycle configuration mainly depends on the imposed requirements or constraints such as type of heat source, efficiency, heat rejection scheme, and weight volume limitation, the levels of intercooling, regeneration and reheat are based on a trade-off between the system performance and specific weight and volume, and cost requirements. Therefore, appropriate parametric analyses have been performed for the baseline cycle configuration selected based on parameters and their ranges identified earlier.

A flow diagram applicable to the baseline cycle configuration indicating three possible turbomachinery arrangement options is shown in Fig. III-1. The results of the parametric performance analysis for the baseline CCGT are presented in Figs. III-5 through III-10.

The turbine inlet temperature is the single most important parameter affecting the thermal efficiency of the power conversion system since a higher turbine inlet temperature offers the potential for higher power conversion efficiency. For this reason, increased turbine inlet temperature is generally regarded as indicative of the advancing turbomachinery technology. The effect of turbine inlet temperature on the baseline cycle thermal efficiency is shown in Fig. III-5. The results indicate that the cycle thermal efficiency increases approximately 1.8 percent per 100 F increase in turbine inlet temperature, and that the optimal pressure ratio for maximum efficiency increases with the increase in turbine inlet temperature. Figure III-6 shows the thermal efficiency and specific work of a closed-cycle gas turbine power system for the turbine inlet temperatures and pressure ratios described above. While the cycle thermal efficiency reaches a maximum value, the specific work continues to increase with the increase in pressure ratio, indicating that the selection of the design point could be a compromise between the thermal efficiency for system economy and the specific work for higher specific power (shp/lb) and/or large unit capacity. Figure III-7 shows the real-world interrelationship between the cycle thermal efficiency and the regenerator effectiveness, allowing appropriate cycle pressure loss variation commensurate with the change in regenerator effectiveness; in traditional analyses of this type, a constant cycle pressure loss is often assumed while the regenerator effectiveness is varied independently. Realistically, the overall cycle pressure loss should approach infinity as the regenerator effectiveness approaches 100 percent. Taking this into consideration, an empirical pressure loss characteristic was incorporated in the performance computation for sensitivity analysis purpose only, and the results are depicted in Fig. III-7. The effect of total pressure loss on the cycle thermal efficiency was found to be approximately 0.5 point decrease in thermal efficiency per one percent increase in pressure loss within the 6 to 14 percent range considered, as shown in Fig. III-8.

A comparison between the thermal efficiencies of the baseline cycle and the alternative cycles (Fig. III-9) indicates that the simple cycle and the cycle with

intercooler only are obviously not acceptable because of their low thermal efficiencies. The cycle with regeneration only could be the first alternative if that cycle with an intercooler exhibits any system integration problem. A combination of all three features (i.e., regeneration, intercooling and reheat) offers a rather attractive level of performance, but its technical feasibility would depend on the type of heat source and the trade-off between the improve cycle thermal efficiency and the weight, volume, and cost characteristics for high temperature heat exchangers. The results of this comparison study also indicates that the baseline configuration selected earlier by using compatibility matrix is technically sound.

Figure III-10 represents the interrelationships among the turbine inlet temperature, regenerator effectiveness, cycle thermal efficiency, heater efficiency, and specific fuel consumption. The cycle thermal efficiency can be easily read from the abscissa for a given turbine inlet temperature (right hand side coordinate) and regenerator effectiveness. The specific fuel consumption was constructed based on the resultant cycle thermal efficiency, heating value of the marine diesel fuel specified, and the heater efficiencies indicated, i.e., 86, 88 and 90 percent, respectively.

Power Conversion System Size and Weight Characteristics

The size and weight characteristics of major components and/or power conversion systems with ratings to 300,000 shp installed capacity were investigated in this task. The baseline engines, identified in Section II and which could serve as building blocks to achieve all the required installed horsepower for the selected ship types, were characterized. The effect of the power turbine rotational speed on the turbine weight was investigated.

Open-Cycle Gas Turbine

Aircraft-derivative open-cycle gas turbines have proven capable of achieving very low specific weights and volumes. The relationships of specific weight and specific volume to horsepower output were established based on a survey of existing engines for several configurations as shown in Figs. III-11 and III-12, and from these graphic data, a comparison was made between the major characteristics of the aircraft- and industrial-derivative engines as each would be installed onboard a naval ship. From this comparison the aircraft-derivative type was chosen, and curves were established which were used to optimize system configurations. Data plotted in Figs. III-11 and III-12 indicate that the gas generator alone (consisting of much the same equipment as installed in an airplane) cannot be expected to achieve a much further reduction in weight and volume with increased power ratings. This is due to both the technological limitations, described previously, as well as the restrictive effect the current business climate is having on costly development programs. When the weights of a power turbine and hardware required for mounting and protective enclosures are added, the specific weight and volume could increase by a factor of ten for units rated at 10,000 shp and by a factor of four for the larger engines rated at 40,000 shp. The addition of regenerators and intercoolers has only been documented in association with industrial-derivative engines which do not require extensive redesign to allow ducting flow away from the compressor. In these latter cases, significant weight and volume increases resulted.

Another noteworthy trend seen in Figs. III-11 and III-12 is the divergence of the weights of industrial- and aircraft-derivative engines as power is increased. This is due primarily to the inherent differences in design philosophy wherein large weight and volume are not terribly costly for stationary, ground-based operations. Furthermore, the large industrial engine hardware is now nearly divorced from aircraft-derivative hardware, while older, smaller engines often had many interchangeable components with their aircraft counterparts. Thus, although large industrial gas turbines are available in power ratings over 100,000 shp they would still be almost twice as heavy and would occupy more than twice the combined volume as would two aircraft-derivative engines of 50,000 shp each. Therefore, only the specific weight and volume characteristics of an enclosed, packaged, aircraft-derivative gas turbine were considered in the system optimization which was undertaken.

In view of the significant impact on the total propulsion system weight, particularly that of the reduction gearbox weight, the power turbine shaft speed of all existing OCGT engines has to be characterized. It is known that the design speed of a power turbine is not only dictated by the design philosophy to meet the established target performance level, but also regulated by a specific application. Figure III-13 represents the speed-power relationship of existing OCGT power turbine design of both aircraft- and industrial-derivative engines. Of course, the trend is influenced by the desired applications. It can be seen that there are two obvious speed levels, 3600 and 3000 rpm, for U.S. and European utility electric generators (60 cycle and 50 cycle power), respectively. A trend line was drawn to represent future large OCGT conceptual designs.

Based on the results of the above survey, the shaft rpm for the four baseline engine sizes (20, 30, 40 and 50 thousand shaft horsepower) selected in Section II can be identified, as shown in Fig. III-13. The characteristics relevant to the present study which are listed in Table III-1 indicate that the specific fuel consumptions of these units varies from 0.395 to 0.380 lb/shp-hr and specific weight ranges from 1.71 to 0.86 pound per shaft horsepower. The output shaft speeds listed in the right column of Table III-1 were selected for reference only; the effect of output shaft speed variations on the weight of the power-turbine is shown in Fig. III-14. Further discussion of the effect of this speed variation on the overall propulsion system weight is presented separately in propulsion system tradeoff analyses to be given later in this Section.

Closed-Cycle Gas Turbine

The component technologies and material capabilities discussed in Section II provided guidelines for estimating the size and weight characteristics of CCGT systems. Detailed sizing and weight estimates were made for the eight baseline engine sizes resulting from the selection matrix (see Fig. II-21), as listed on Table III-3. An extensive computer-aided preliminary design study aimed at estimating component size and weight characteristics was then conducted. Many design concepts and parameters established at UTRC (by the Power Systems Division and the P&WA Group), were incorporated selectively in the computer program to ensure consistent estimates over a wide power range. A brief discussion of this program is presented in Appendix F.

Before component size and weight characteristics can be estimated, applicable materials and their properties have to be established. Materials suitable for the CCGT components design were selected on the basis of mechanical and physical properties which would be compatible with the required applications, metallurgical stability, and low cost. The materials selected are presented in Table III-2. The use of disks and blades of the same material has been avoided to aid in preventing self-welding and excessive galling of these components during service operation.

Additional precautions, such as the use of an antigallant, were assumed to be employed to yield acceptable friction and wear behavior at the blade-disk interfaces. In addition, rotating components were assumed to be fabricated from material produced either by electroslog or vacuum remelting to optimize strength, toughness, and to reduce impurities. The material AISI 410, which sometimes is designated as CA-15, has very high tensile strength, good weldability, and moderate oxidation-corrosion resistance and has been used frequently in compressor components operating at temperatures up to 850 F. General applications of this material are foreseen in compressor vanes, disks, and cases. The selection of turbine materials was made with emphasis on long-term, strength at elevated temperatures as well as metallurgical stability; therefore, cast IN-100 was selected for this application. The use of the precipitation-hardened A-286 superalloy for turbine disks was dictated by the desire to avoid the high cost of nickel base alloys and the excessive cooling air needed in the blade attachment region. The materials for both compressor and turbine tiebolts, seals, and spacers were not designated because they are not needed in the preliminary sizing and weight estimates. The high-strength, low-alloy steel, Ladish D6AC was chosen for the shafts to minimize weight. Compared to similar steels containing a greater amount of nickel, this material when tempered to yield good fracture toughness, is less prone to temper embrittlement, making it less sensitive to overtemperature conditions. Either Hastelloy X or IN-718 could be used for the turbine cases, high temperature ducts, and structural components (including the turbine inlet strut) that require good strength at elevated temperatures. Monel, known to have excellent resistance to corrosion to both natural water and salt water, is an ideal choice for the intercooler and pre-cooler tube material, while AISI 347, with its good oxidation-corrosion resistance up to 1500 F, was selected for the heat exchanger shell material. The helium environment in which the CCGT would operate is not expected to affect component life adversely at the low strains that occur during service. Although they are not in complete agreement, several studies have indicated that at low stress levels where tertiary creep is avoided during component life, the helium environment involved in this application should not significantly change the material properties from those associated with tests in air.

Based on the noted material selections, parametric designs of the major components of the eight baseline CCGT power conversion systems were undertaken. The results of analyses based on these designs are presented in Figs. III-15 to III-22. Parametric analysis results for the turbomachinery are presented in Figs. III-15 through III-18. For each selected unit capacity level, the acceptable (not optimal) shaft speed range which would lead to reasonable and mutually compatible design parameters was identified. This was accomplished by examining the computer print-out generated from a wide range of selected input speeds to check whether or not the results are agreeable with the design practice established in the past. For example, the shaft speed directly affects the turbomachine diameters (tip and hub, etc.) flow coefficient, blade geometry and stress levels, and the number of stages required. The desirable speed for the gas generator (i.e., turbocompressor) often can be determined independently from that of the power turbine if multishaft systems (see Fig. III-1, middle and bottom illustrations) are used, particularly in the low

horsepower range. The optimal shaft speed for the power turbine, on the other hand, will depend not only on its own aerodynamic design requirements, but also on the potential impact it will impose on the performance and weight characteristics of other propulsion system components, in particular those of the gearbox, and to a lesser degree, the thruster and shafting. Therefore, sizing and weight estimates for the power turbine modules were made parametrically for the shaft speed range judged to be practical for the turbine design, yet desirable from the overall system integration viewpoint. The selected reference design speeds for both turbocompressor set and power turbine are shown in Fig. III-15. There the shaded areas represent the ranges of power turbine speeds used to investigate the effect of speed on the selected propulsion systems. During this analysis, no excessive stress levels were encountered in the parametric designs based on the turbine inlet temperatures and system lifetimes considered. Figure III-16 and the three lower curves of Fig. III-17 show the estimated turbomachinery size and weight for the three candidate turbomachinery configurations (namely, direct drive, one-power turbine, or two-power turbines, see Fig. III-1) at the eight baseline engine unit capacities required. The major characteristics for these baseline engines are summarized in Table III-3. It should be noted that lower turbine inlet pressures were utilized for the lower-unit-capacity turbomachines to avoid encountering unreasonable component dimensions and operating conditions. The specific weight of bare engines alone varied from 0.320 to 0.246 pound per shaft-horsepower as shown in the right column of Table III-3. When supporting and static structures are added, the results correspond to those of the lower three curves in Fig. III-17. Figure III-18 presents the results of a parametric design weight analysis for the power turbines of different capacity as affected by the shaft speed. Reducing the power turbine shaft rpm could lead to reduced gearbox weight, but only at the expense of an increase in the engine weight and cost. The optimum power turbine rpm is discussed in more detail in the next subsection on tradeoff analysis.

The results of parametric size and weight estimates for the three major heat exchangers (i.e., regenerator, precooler, and intercooler) are presented in Figs. III-19 to III-22. For reasons of good structural integrity and high reliability, the tube-and-shell type design was considered, and all commercially available tube sizes, ranging from 0.25 to 0.75 inches OD, were investigated. It was found that when smaller tube sizes are used, the heat exchanger would be lighter in weight and more compact in size. However, it is estimated that more advanced fabrication technologies would be needed to utilize the smaller tube sizes. A typical example of the effect of tube size on the regenerator active tube length and package diameter for various regenerator effectiveness is shown in Fig. III-19; the corresponding specific weight is shown in Fig. III-20.

The second parameter studied was the tube pitch or tube center-to-center distance. For the regenerator, the pitch was determined through an iteration process which took into account the magnitude of the heat transfer coefficient for both tube and shell sides and the pressure drop in the high- and low-pressure gas flowpaths

that would still satisfy the desired thermodynamic cycle performance . In the precooler and the intercooler, the flow conditions of the cooling water on the tube side are independent of the cycle performance and only require that a reasonable tube pitch be chosen which will provide appropriate gas/water flow area ratio, thus velocity ratio for the gas and cooling water flow. Four different tube pitch-diameter ratios, 1.30, 1.40, 1.50 and 1.60 were investigated. The cooling water flow velocity inside the tube was also varied from 5 to 10 feet per second, but it was found that this velocity was not a significant parameter in size and weight study when water side temperature rise is not restricted. Figures III-21 and III-22 show the size and weight characteristics of the three heat exchangers at reference design condition for the baseline engine sizes considered.

The power conversion system weight for the three turbomachinery configurations considered were then estimated by summing the weight of turbomachinery, heat exchangers, ducting, and supporting structures. The results are shown in the upper part of Fig. III-17. These weight estimates do not include the weight of a heater which will be studied in the follow-on Part II study program. It was estimated that at a rating of 40,000 shp, the engine specific weight is approximately 2.5 pound per shaft horsepower, whereas at 200,000 shp the specific weight decreased to a value of approximately 1.5 lb/shp.

Propulsion System Trade-Off Analysis

The preceding discussions have related to the establishment of the specific weight levels of open- and closed-cycle propulsion engines, including installation packaging and mounting supports. It is now necessary to discuss how these estimates were combined with the estimates for gearbox, shafting, and thruster to estimate total ship propulsion system specific weight, for the selected baseline engines and installed power levels.

The basic arrangements of engine and gearbox considered are already shown in Fig. II-21, and their applicability to reference installed power levels are evaluated in a matrix which also indicates the compatible thruster types. The choice of these combinations is the result of previously determined limitations on engine, gearbox, and thruster in conjunction with ship type, displacement, speed, and power requirements. With the help of this selection matrix, sixteen OCGT systems and twenty-one CCGT systems were selected for a trade-off analysis. This trade-off analysis included variations of power turbine speed (high, reference, and low speeds) and gearbox types (offset, and epicyclic). Since each reference power level was applicable to several different ship types, there were 176 OCGT and 254 CCGT propulsion systems investigated. The propulsion identification code defined in Section II was utilized to simplify bookkeeping procedures. A selected sample of this bookkeeping approach is presented in Table III-4 to describe the propulsion system configuration and the corresponding specific weights of power conversion system (W_{PCS}), gearbox (W_{gb}) and shafts (W_s). The results are also shown in Figs. III-23 to III-28.

Results presented in Figs. III-23 and III-24 show the engine-plus-gearbox specific weight as a function of installed shaft horsepower for open-cycle and closed cycle gas turbines at three ship speeds. These results serve the dual purposes of overviewing the weight ranges and identifying the minimum system weight. For the power conversion system and gearbox alone (see Fig. III-23), the weight of the open-cycle system is approximately 4.1 to 4.9 lb/shp for a 26-knot ship, 2.5 to 3.5 lb/shp for a 35-knot ship, and 1.2 to 2.0 lb/shp for a 50-knot ship. The comparable estimates of CCGT systems, excluding heater weight, is shown in Fig. III-24. The sensitivity analysis of power turbine shaft speed indicated that the minimum system weight does not always occur at the reference design speed. For example, many of these studies showed that, for 35-knot ships, utilizing multiple open-cycle engines and offset gearboxes (Basic Arrangement E), an increase in the power turbine speed would reduce the system weight. However, for the same ship utilizing closed-cycle engines integrating with single input/output gearboxes (Basic Arrangements B and D), a reduction in power turbine speed would reduce the system weight. The total weight deviation from the reference design was found to be less than 0.1 pound per shp. Due to these insignificant weight savings in comparison with the total system weight, the established reference designs for both open- and closed-cycle engines were used in all further analyses.

The estimated weight data of the engine-plus-gearbox for the reference design were extracted from Figs. III-23 and III-24 and replotted as a function of unit power in Figs. III-25 and III-26. It should be noted that the discontinuity on each curve is due to the change in gearbox selection from a nonreversible type to a reversible type based on the aforementioned gearbox limitations. The application of these results are shown in Figs. III-27 and III-28 for the total propulsion system weight which includes engine, gearbox, and shafting. Figure III-27 shows specific weights of OCGT systems, without thrusters, of approximately 4.0 to 8.2 lb/shp for 35 knot ships and 1.8 to 2.2 lb/shp for 50-knot ships. Figure III-28 indicates that systems powered by closed-cycle engines without a working fluid heater, inventory system, or thruster would have a specific weight of 6 to 9 lb/shp for 35-knot ships. The higher speed of supercavitating propellers or water jet systems should allow lower specific weights of 2.7 to 3.2 lb/shp to be achieved.

For both the open- and closed-cycle engine systems estimated to be available by 1990, the lowest system weight would be provided by utilizing the maximum practical number of thrusters per ship in combination with epicyclic gearboxes. Above a rating of 50,000 shp per thruster, an offset gearbox, which allows multiple engine input shafts to be accommodated must be used for the open-cycle systems since the highest power level projected for open-cycle systems by 1990 is 50,000 shp. Closed-cycle engines can utilize epicyclic gearboxes throughout the power range, and hence, take advantage of the lower specific weight for epicyclic systems. Furthermore, as was seen in Fig. III-4, open-cycle systems require multiple engines per thruster to produce reasonable part-load specific fuel consumption without having to resort to separate cruise engine(s); whereas, closed-cycle systems require neither. This means that open-cycle systems will probably be required to use the heavier, multiple-input offset gearboxes as shown by Arrangement E. Closed-cycle systems can utilize the lower-weight system Arrangements A, B, or D, shown in Figs. III-25 and III-26, without incurring severe part-load fuel-use penalties. Since fuel weight is often the major portion of total propulsion system weight, the impact of this characteristic on the total propulsion systems, including fuel weight, is very significant.

In this study, closed-cycle Arrangement A, B or D should be compared to the open-cycle Arrangement E. In such a comparison, the closed-cycle system, exclusive of working fluid heater, controls and thruster, is lower in specific weight for 26- and 35-knot ships and within 0.1 lb/shp for a 50-knot displacement ship with supercavitating or water jet thrusters vis a vis the open-cycle applications. Furthermore, if four propulsion engines are assumed to be the maximum allowable number onboard a ship, then only the closed-cycle system can supply more than 200,000 shp.

Propulsion System-Plus-Fuel Weight

The weight characteristics of lightweight propulsion systems including power conversion systems (OCGT and CCGT), reduction gearbox, and shafting are discussed

in the previous section. The payload capability of each selected ship type powered by the lightweight propulsion systems was analyzed, and the possible constraints which could affect the CCGT heater design identified. The results of this analysis are discussed in the following paragraphs.

Component Weight Breakdown

Table III-5 tabulates breakdowns of the major component weights for three ship types, i.e. conventional destroyers, high-speed destroyers, and high-performance ships. For these tabulations, the weights of bed plate, thrusters, and combustion gas intakes and uptakes were estimated from DD963 and SES data complemented by engineering judgment in anticipation of technological improvements. For example, the weight of the bed plate in a DD963 is equal to approximately 60 percent of power conversion system weight. Therefore, a factor of 2/3 was used to estimate the weight of bed plates for other systems. Thrustor weight was based directly on existing design data. Although the uptake weight of DD963 is approximately 3.6 lb/shp, it is believed possible that this weight could be halved if advanced technologies were incorporated. ONR was consulted about this point and is in agreement with this assumption. Finally, the combined weight of the unidentified, miscellaneous components, such as control equipment, fuel and oil treatment systems, pumps, generators, etc., are estimated to be 30 percent of the subtotal weight. It should be noted that uptake of the CCGT systems was not specifically identified since it is considered as a part of the heater weight. The detailed characteristics of these heaters will be identified early in the follow-on Part II study.

Propulsion System-Plus-Fuel Weight -- Duty Operation

Although the line of Table III-6 entitled "Propulsion System Specific Weight, lb/shp" indicates that the total weight of CCGT propulsion systems based on the assumed heater weight appears heavier than for the corresponding OCGT systems, the potential benefits of the closed-cycle system become apparent when the weight of fuel required by ships to operate for a given period of time is calculated. This weight was calculated by multiplying the appropriate part-load specific fuel consumption values by the corresponding number of hours specified by the duty cycle spent at each power level. The duty cycle and power requirements were defined in Section I, whereas the sfc and part-load power characteristics were shown in Fig. III-4. The fossil fuel consumption characteristics are summarized in Table III-6 for selected ship types undergoing duty or cruise operation.

The estimated weights of the propulsion system equipment-plus-fuel based for up to 500 hours of duty cycle operation are presented graphically in Figs. III-29 to III-31, respectively, for the conventional destroyers, high-speed destroyers, and high-performance ships. Because of their part-load fuel use characteristics, the rate of fuel used by closed-cycle engines undergoing duty operation is less (see Table III-6), and hence the slope of the plot of propulsion system-plus-fuel

weight is lower for closed- than for open-cycle systems. Figure III-29 shows that this combined weight of the closed-cycle system plot intersects that of the open-cycle at approximately 180 to 250 hours of endurance, depending on the maximum closed-cycle temperatures selected. If the closed-cycle propulsion system used a nuclear heat source rather than one heated with fossil fuel, the resulting plot essentially defines a region of constant specific weight which becomes a function of the assumed reactor plant weight of 10 to 20 lb/shp. Similar phenomena are also shown in Figs. III-30 and III-31. It can be seen from these results that the open-cycle system consistently offers the lowest total weight in the low endurance ranges and that the nuclear-powered, closed-cycle system is the best in the increased endurance ranges for all ships. Furthermore, the future potential of fossil-powered closed-cycle engine systems depends on the allowable maximum cycle temperature and is the least pronounced for high-performance ships among the three ship types compared.

Propulsion System-Plus-Fuel Weight -- Cruise Operation

Estimates of propulsion system-plus-fuel weights for all-cruise operation were also made for various selected ship types, and the results are shown in Fig. III-32. The results shown for CCGT system were calculated based on turbine inlet temperature of 1500 F. The results for the cruise conditions are similar to those of the duty-cycle operation, in that the CCGT system characteristics also intersect the OCGT characteristics, although at different endurance times. This phenomenon is due to the differences in propulsion system efficiencies at constant-speed, part-load cruise and variable-speed part-load duty cycle operation.

Payload Capability Analyses

Comparisons of payload capabilities for the three ship types were made in order to identify the range of specific weights for the CCGT heat sources which correspond to different endurance ranges and payload capacities. The results of these calculations are shown in Figs. III-33 to III-35. In these figures, the percent payload is defined as:

$$\text{Payload (\%)} = 100 - \frac{\text{Structure Wt.} + \text{Propulsion System Wt.} + \text{Fuel Wt.}}{\text{Total Displacement}}$$

The results in Fig III-33 indicate that, at a fossil heater weight of 4 lb/shp, the CCGT system will exhibit better capabilities at all endurance periods greater than 100 hours than a similar vessel operated with an OCGT system. Similar information is shown in this figure for two higher (8 lb/shp and 12 lb/shp) levels of heater weight. For CCGT systems powered by nuclear heat sources, the estimated constant payload fractions for three reactor weights levels are shown in the same figure. In addition, the results presented in Figs. III-33 to III-35 also show the interrelationship among

the payload, the endurance, and the propulsion system weight. For example, if a combined requirement for a 30-percent payload and a 40-hour endurance level are required for high-performance ships, the results presented in Fig. III-35 clearly indicate that both the OCGT and fossil-fired CCGT systems are not feasible. Comparisons of the payload capability for the three selected ship types powered by lightweight, fossil-fueled propulsion systems (OCGT and CCGT) are shown in Fig. III-36.

The maximum allowable specific weights of heat sources for CCGT propulsion systems capable of providing the same payload capability as OCGT systems were estimated from Figs. III-33 to III-35. These estimates are shown in Fig. III-37, where the solid-line curves correspond to fossil-heater data and the broken-line curves correspond to nuclear heater data. It becomes clear that the specific weight of the heat source required for CCGT systems should be less than those noted in order to assure that CCGT systems are competitive from a payload standpoint, with OCGT systems.

R77-952566-5

TABLE III-1

SELECTED BASELINE OCGT ENGINE CHARACTERISTICS

<u>Output Power,(shp)</u>	<u>sfc (lb/shp-hr)</u>	<u>Specific Weight, (lb/shp)</u>	<u>Pressure Ratio</u>	<u>Turbine Inlet Temperature, (F)</u>	<u>Output Shaft Speed, (rpm)</u>
20,000	0.395	1.71	20	2,400	4,800
30,000	0.390	1.32	22	2,450	4,200
40,000	0.385	1.10	25	2,500	3,800
50,000	0.380	0.96	28	2,550	3,600

TABLE III-2

CCGT COMPONENT MATERIAL SELECTIONS

<u>Component</u>	<u>Material</u>
Compressor	
Blades and Vanes	AISI410
Disks, Hubs and Seals	IN718
Turbine	
Blades and Vanes	IN100
Disks, Hubs, and Seals	A-286
Shaft	Ladish D6AC
Cases, Mounts, Ducts	
Low Temperature Area	AISI410
High Temperature Area	Hastelloy X or IN718
Heat Exchanger	
Intercooler Tube/shell	Monel/AISI347
Precooler Tube/shell	Monel/AISI347
Regenerator Tube/Shell	Hast-X/AISI347

R77-952566-5

TABLE III-3
CCGT BASELINE ENGINE CHARACTERISTICS

<u>Output Power,</u> <u>(1000 shp)</u>	<u>Cycle Pressure,</u> <u>(psia)</u>	<u>Power Turbine,</u> <u>(rpm)</u>	<u>Specific Weight,</u> <u>(lb/shp)</u>
40	580	5400	0.320
60	620	5200	0.286
80	650	4800	0.275
100	680	4600	0.262
120	720	4400	0.253
150	760	4000	0.251
160	780	4000	0.247
200	840	3800	0.246

TABLE III-4

SAMPLE OF ESTIMATED CCGT MAJOR COMPONENT WEIGHT FOR LWSPS

Turbine Inlet Temperature = 1500 F

Installed Horsepower = 80,000 Shp

Ship Speed = 35 knots

 W_{pcs} = Power conversion system weight - lb/shp W_{gb} = Gear box weight - lb/shp W_s = Shaft weight - lb/shp

Case No.	LWSPS Identification Code	W_{pcs}	W_{gb}	W_s
50	FC80/LB (KKT8200/1T4200)(1102R)(F160)	1.94	2.67	3.85
51	FC80/LB (KKT8200/1T4200)(1102R)(F160)	1.94	2.57	3.85
52	FC80/LB (KKT8200/1T4800)(1102R)(F160)	1.87	2.73	3.85
53	FC80/LB (KKT8200/1T4800)(1102R)(F160)	1.87	2.63	3.85
54	FC80/LB (KKT8200/1T5400)(1102R)(F160)	1.84	2.78	3.85
55	FC80/LB (KKT8200/1T5400)(1102R)(F160)	1.84	2.69	3.85
56	FC80/1C (KKT8200/1T4200)(1201N)(F230)	1.94	2.15	2.35
57	FC80/1C (KKT8200/1T4200)(1202R)(F230)	1.94	2.49	2.35
58	FC80/1C (KKT8200/1T4800)(1201N)(F230)	1.87	2.19	2.35
59	FC80/1C (KKT8200/1T4800)(1202R)(F230)	1.87	2.52	2.35
60	FC80/1C (KKT8200/1T5400)(1201N)(F230)	1.84	2.23	2.35
61	FC80/1C (KKT8200/1T5400)(1201R)(F230)	1.84	2.55	2.35
62	FC80/1D (KKT8200/2T4600)(1102N)(F230)	2.00	1.61	2.35
63	FC80/1D (KKT8200/2T4600)(1102R)(F230)	2.00	1.91	2.35
64	FC80/1D (KKT8200/2T4600)(1102N)(F230)	2.00	1.60	2.35
65	FC80/1D (KKT8200/2T4600)(1102R)(F230)	2.00	1.83	2.35
66	FC80/1D (KKT8200/2T5400)(1102N)(F230)	1.97	1.67	2.35
67	FC80/1D (KKT8200/2T5400)(1102R)(F230)	1.97	1.95	2.35
68	FC80/1D (KKT8200/2T5400)(1102N)(F230)	1.97	1.65	2.35
69	FC80/1D (KKT8200/2T5400)(1102R)(F230)	1.97	1.88	2.35
70	FC80/1D (KKT8200/2T6200)(1102N)(F230)	1.94	1.71	2.35
71	FC80/1D (KKT8200/2T6200)(1102R)(F230)	1.94	1.99	2.35
72	FC80/1D (KKT8200/2T6200)(1102N)(F230)	1.94	1.70	2.35
73	FC80/1D (KKT8200/2T6200)(1102R)(F230)	1.94	1.92	2.35

TABLE III-5

PROPULSION SYSTEM COMPONENTS WEIGHT BREAKDOWNS

	Destroyer		H.S. Destroyer		HPS	
Speed, Max./Cruise	35/20		50/20		80/30	
Displacement, long tons	6250		4000		3000	
Installed Power, shp	80,000		160,000		200,000	
Displacement/Power, lb/shp	170		55		33	
Total Structure/Displacement	.45		.45		.30	
Structure Sp. Wt.	76.5		24.75		9.9	
Propulsion Syst. Sp. Wt, lb/shp	OCGT	CCGT	OCGT	CCGT	OCGT	CCGT
Power Conversion	1.71	1.97	1.1	1.64	1.22	1.87
Bed Plate	1.14	1.31	.73	1.09	.81	1.21
Gear Box	1.7	1.65	1.76	0.45	1.76	0.45
Shafting	2.3	2.3	0.55	0.55	0.34	0.35
Thrustor	1.2	1.2	0.5	0.5	0.35	0.35
Uptake	1.8	*	1.8	*	1.2	*
Subtotal	9.85	8.43	6.44	4.23	5.68	4.20
Others	2.96	2.53	1.93	1.27	1.70	1.28
Heater	-	7.0	-	6.0	-	5.0
Total	12.81	17.96	8.37	11.50	7.38	10.50

TABLE III-6

FOSSIL FUEL CONSUMPTION CHARACTERISTICS
FOR SELECTED NAVAL SHIPS

Ship Types	Destroyer		H.S. Destroyer		HPS	
Displacement	6,200 long tons		4,000		3,000	
Max/cruise speed	35/20 knots		50/20		80/30	
100 hr duty range	1945 n. miles		3055		4620	
Propulsion system	OCGT	CCGT	OCGT	CCGT	OCGT	CCGT
1000 shp	80	80	160	160	200	200
arrangement	2 E	1 D	2 E	1 D	2E+B	2B+B
lb/shp	12.8	17.9	8.4	11.5	7.4	10.6
Displacement/power lb/shp	170	170	55	55	33	33
100 hr fuel, lb/shp duty	9.9	7.5	13.4	11.1	22.1	20.0
cruise w/o cruise eng.	8.6	6.0	6.5	3.3	14.5	11.9
cruise with cruise eng.	6.6	--	4.7	--	13.1	--

SCHEMATIC DIAGRAM OF CLOSED-CYCLE GAS TURBINE POWER CONVERSION SYSTEMS

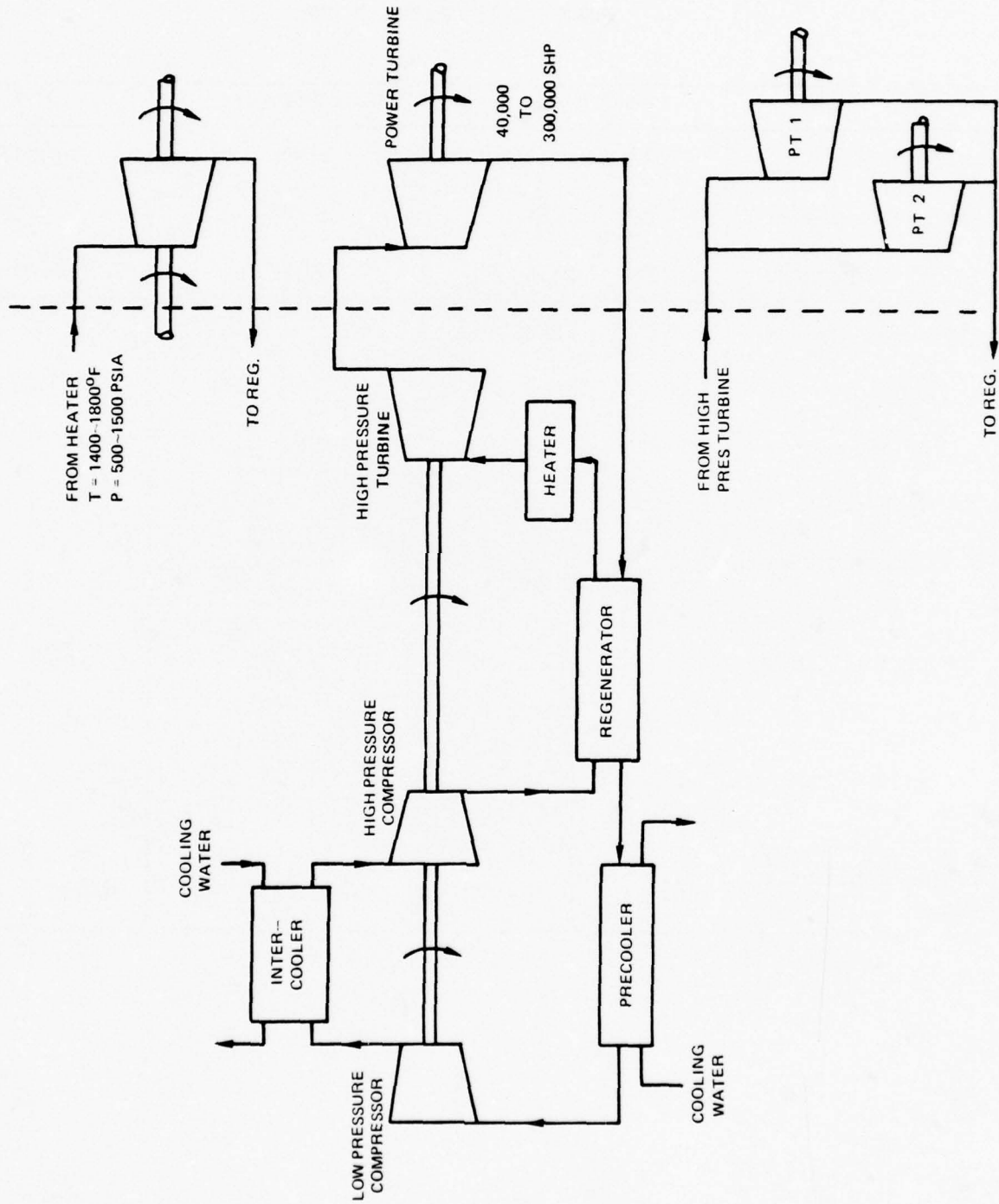

OPEN - CYCLE GAS TURBINE PERFORMANCE

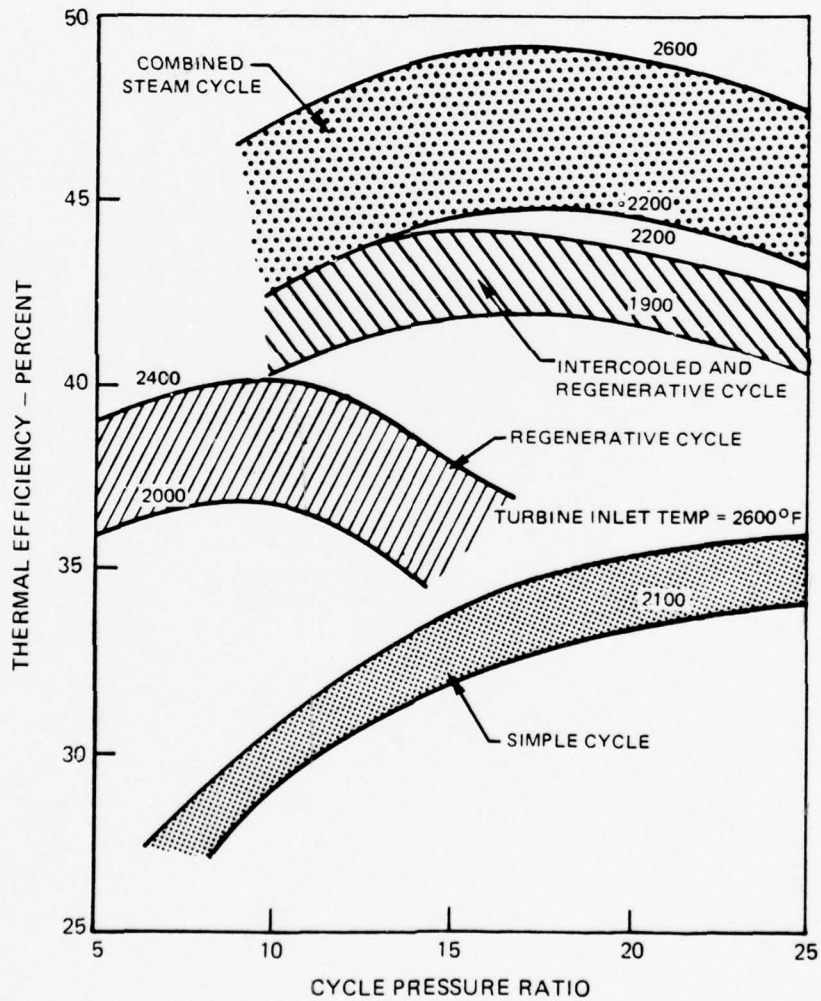

OPEN - CYCLE GAS TURBINE DESIGN POINT PERFORMANCE

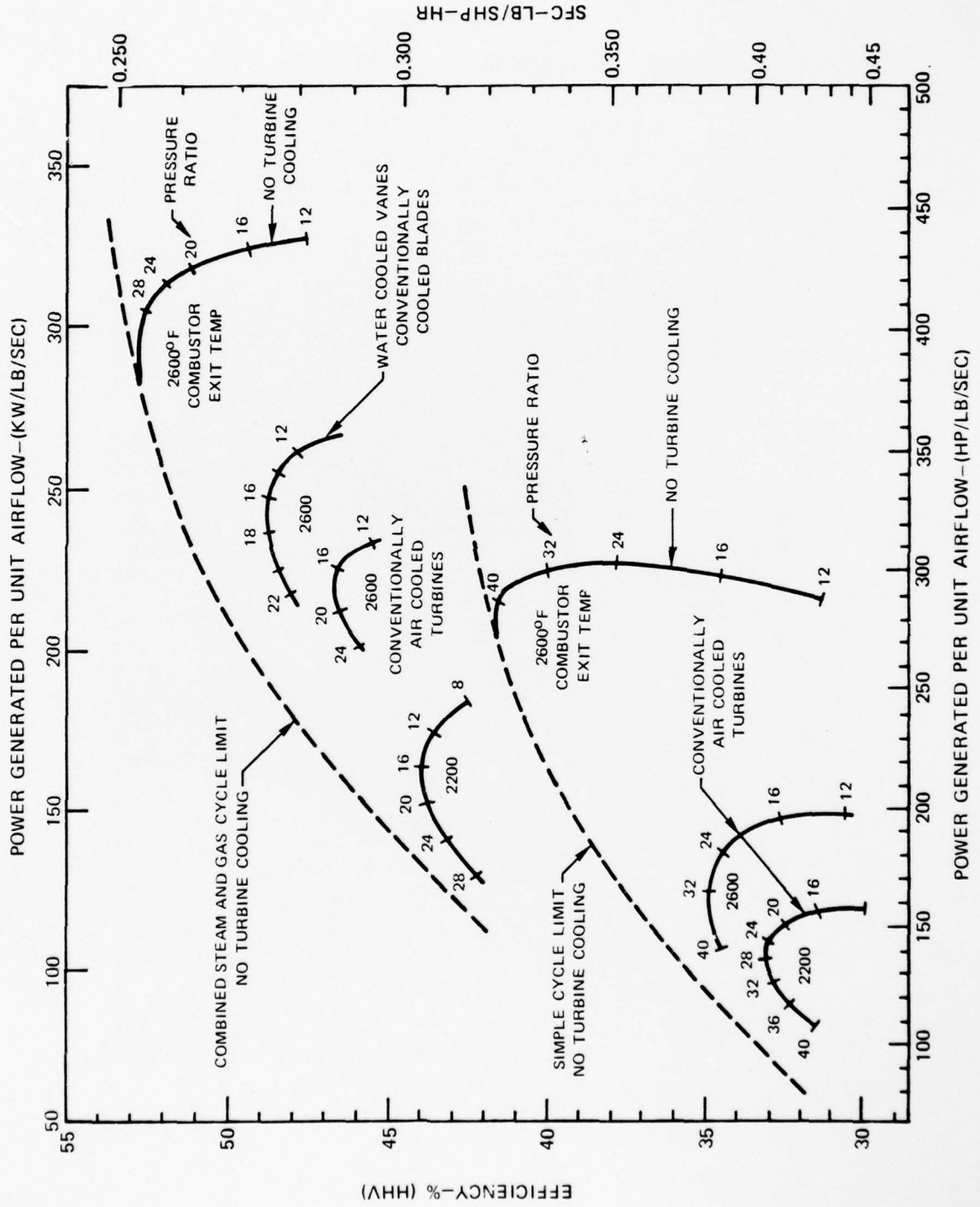

OPEN- AND CLOSED-CYCLE GAS TURBINE PART LOAD PERFORMANCE CHARACTERISTICS

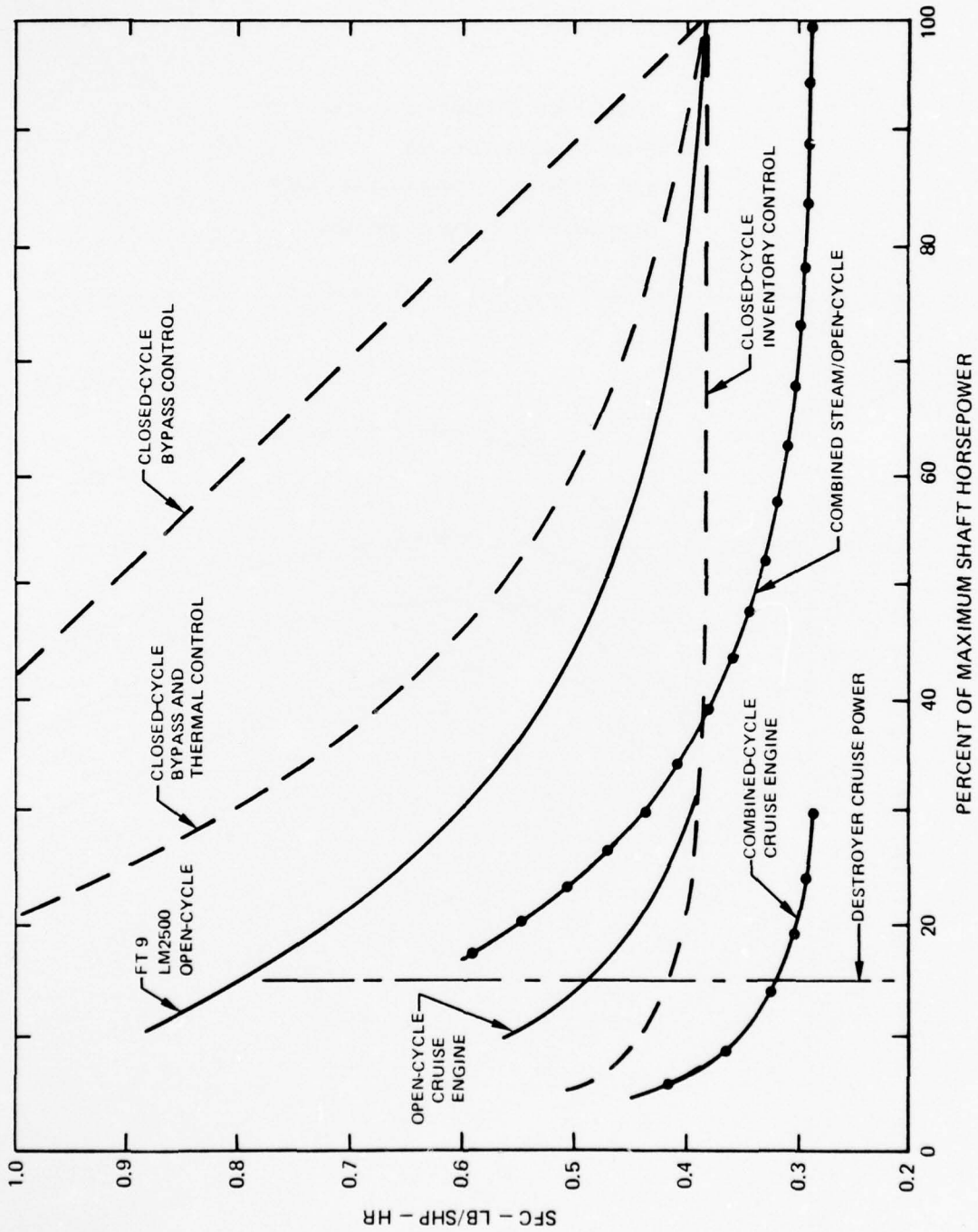

EFFECT OF TURBINE INLET TEMPERATURE ON THERMAL EFFICIENCY OF CLOSED-CYCLE HELIUM GAS TURBINE POWER SYSTEM

TURBINE INLET PRESSURE = 1000 PSIA
CYCLE PRESSURE LOSS = 10%
COMPRESSOR INLET TEMPERATURE = 100°F
REGENERATOR EFFECTIVENESS = 85%

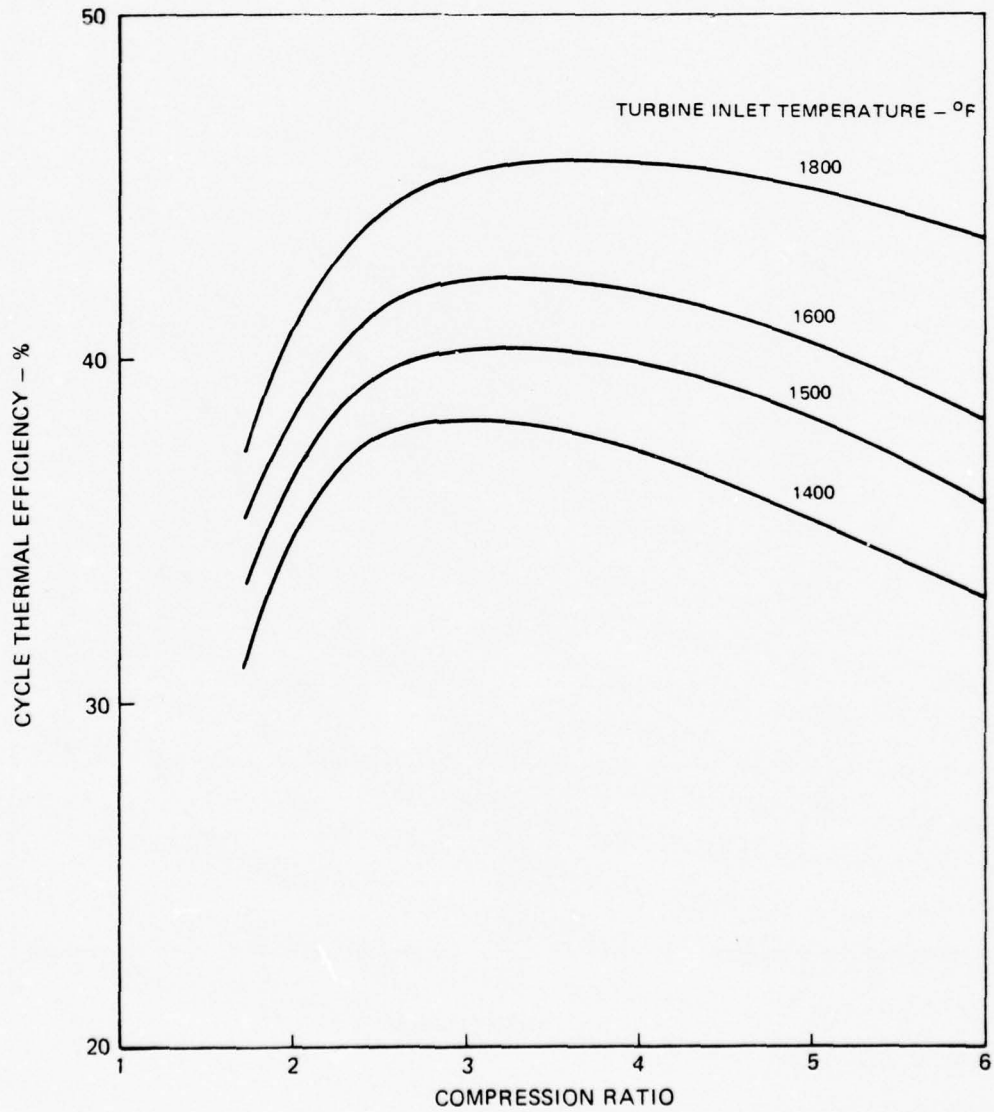

THERMAL EFFICIENCY AND SPECIFIC WORK OF A CLOSED-CYCLE HELIUM GAS TURBINE POWER SYSTEM

TURBINE INLET PRESSURE = 1000 PSIA
COMPRESSOR INLET TEMPERATURE = 100°F
CYCLE PRESSURE LOSS = 10%
REGENERATIVE EFFECTIVENESS = 85%

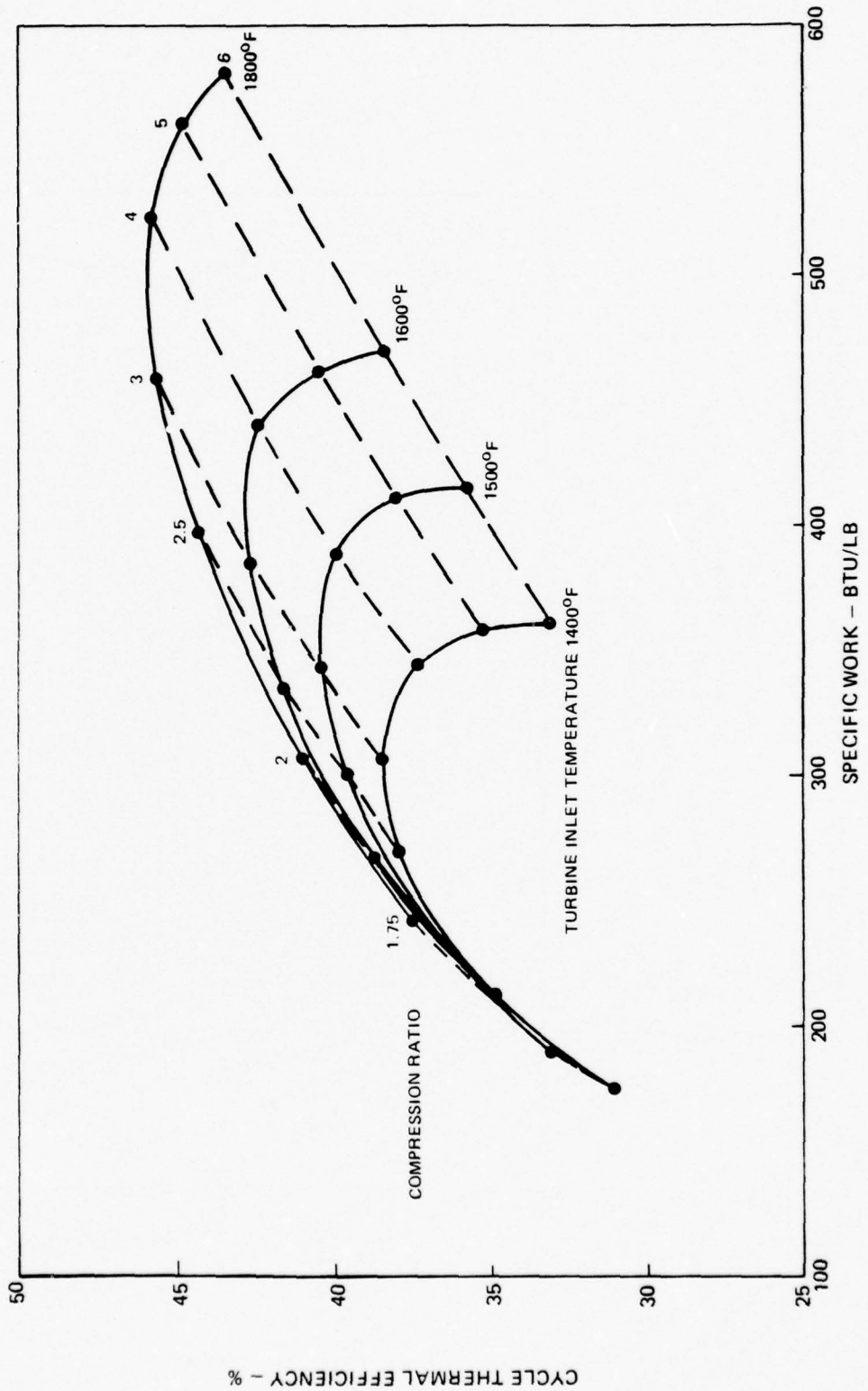

EFFECT OF REGENERATOR EFFECTIVENESS ON THERMAL EFFICIENCY OF CLOSED-CYCLE HELIUM GAS TURBINE POWER SYSTEM

TURBINE INLET TEMPERATURE=1500°F
TURBINE INLET PRESSURE=1000 PSIA
COMPRESSOR INLET TEMPERATURE =100°F
COMPRESSION RATIO=2.75

f = PRESSURE LOSS COEFFICIENT
 η = REGENERATOR EFFECTIVENESS

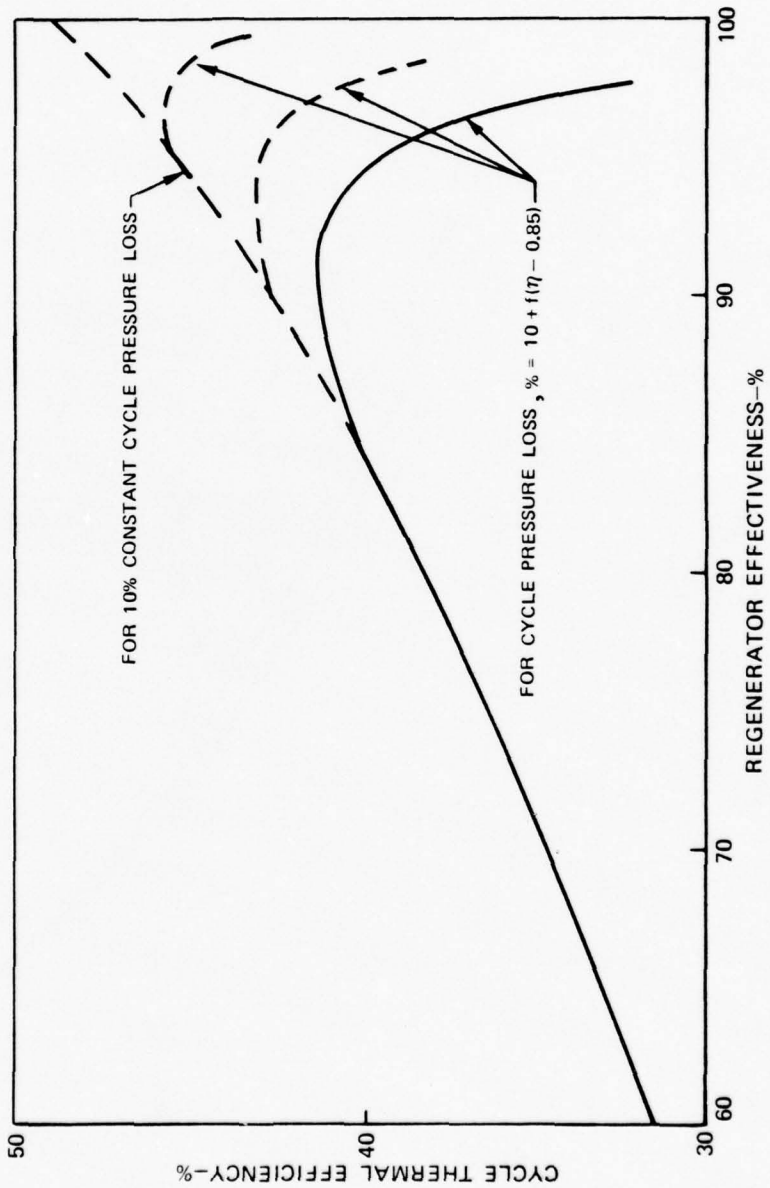

EFFECT OF CYCLE PRESSURE LOSS ON THERMAL EFFICIENCY OF CLOSED-CYCLE HELIUM GAS TURBINE POWER SYSTEM

TURBINE INLET PRESSURE = 1000 PSIA
REGENERATOR EFFECTIVENESS = 85%
COMPRESSOR INLET TEMPERATURE = 100°F
COMPRESSION RATIO = 2.75

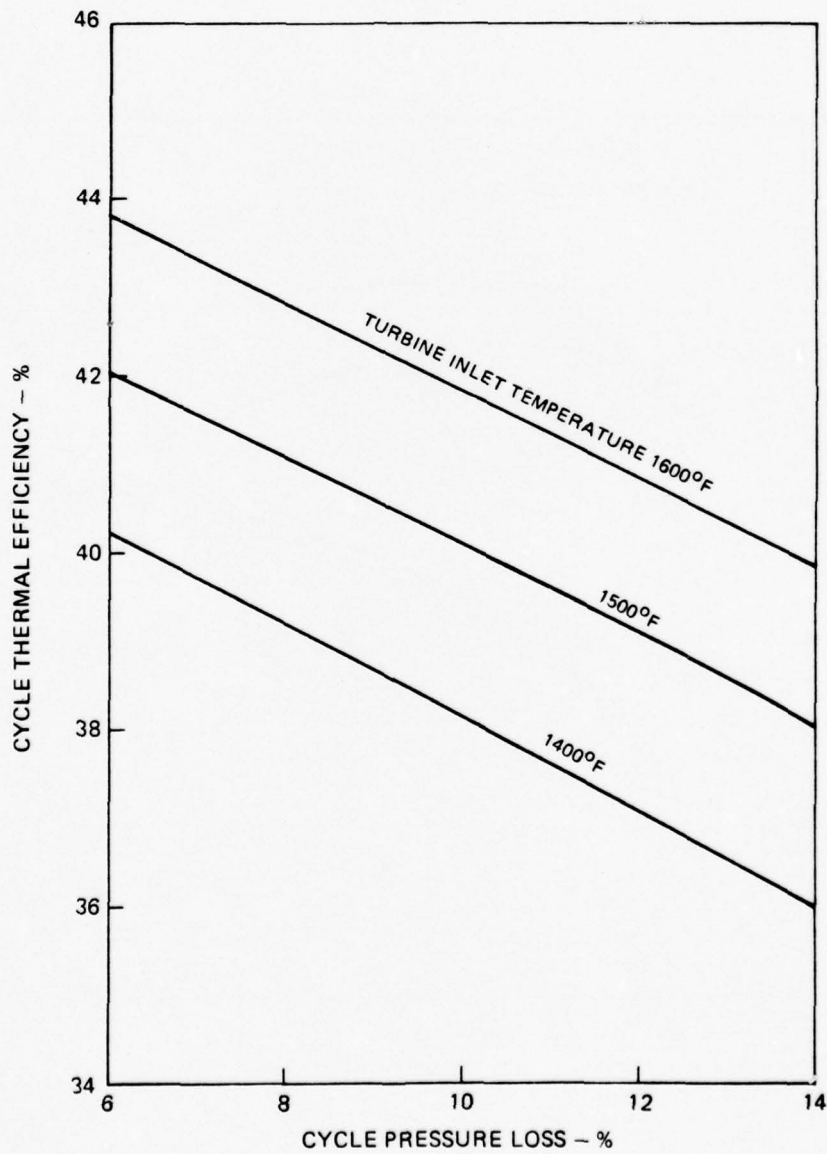

COMPARISON OF CYCLE THERMAL EFFICIENCY FOR VARIOUS CLOSED-CYCLE HELIUM GAS TURBINE POWER SYSTEMS

TURBINE INLET TEMPERATURE 1500°F

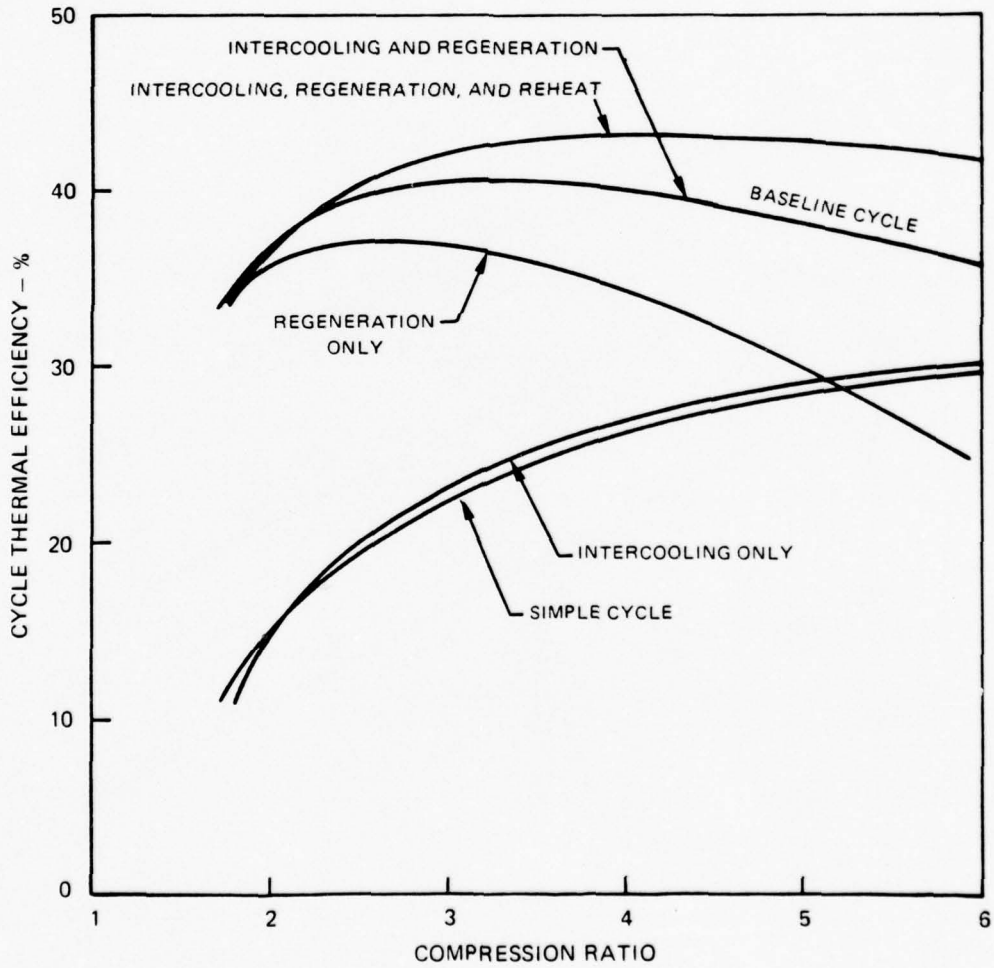

CYCLE THERMAL EFFICIENCY AND SPECIFIC FUEL CONSUMPTION FOR CCGT POWER CONVERSION SYSTEMS

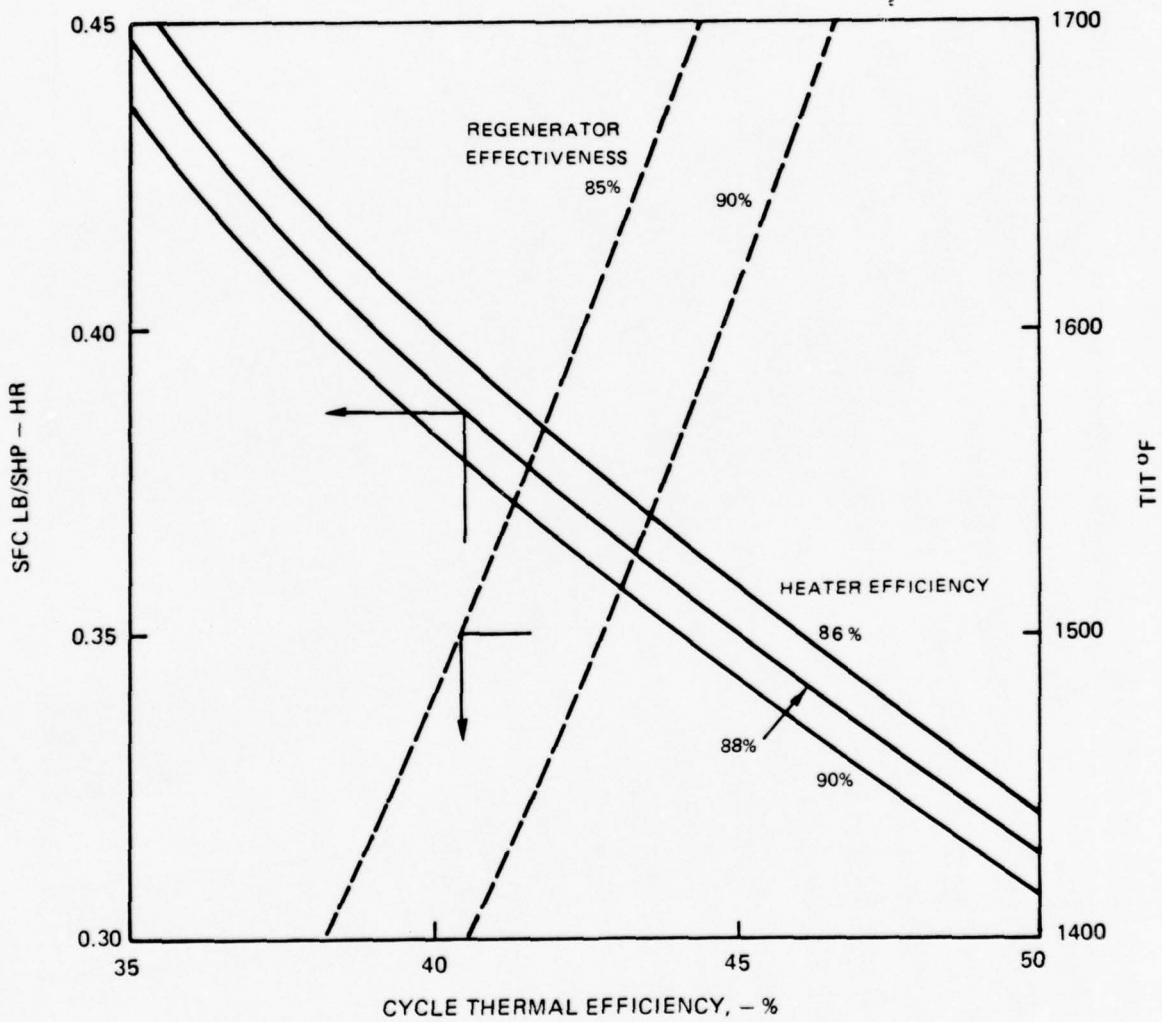

COMPARISON OF OPEN-CYCLE GAS TURBINE SPECIFIC WEIGHTS

- △ AIRCRAFT DERIVATIVE
- INDUSTRIAL AND ACCESSORY
- ▽ AIRCRAFT DERIVATIVE w/o POWER TURBINE
- INDUSTRIAL
- ◇ AIRCRAFT DERIVATIVE w/o ENCLOSURE

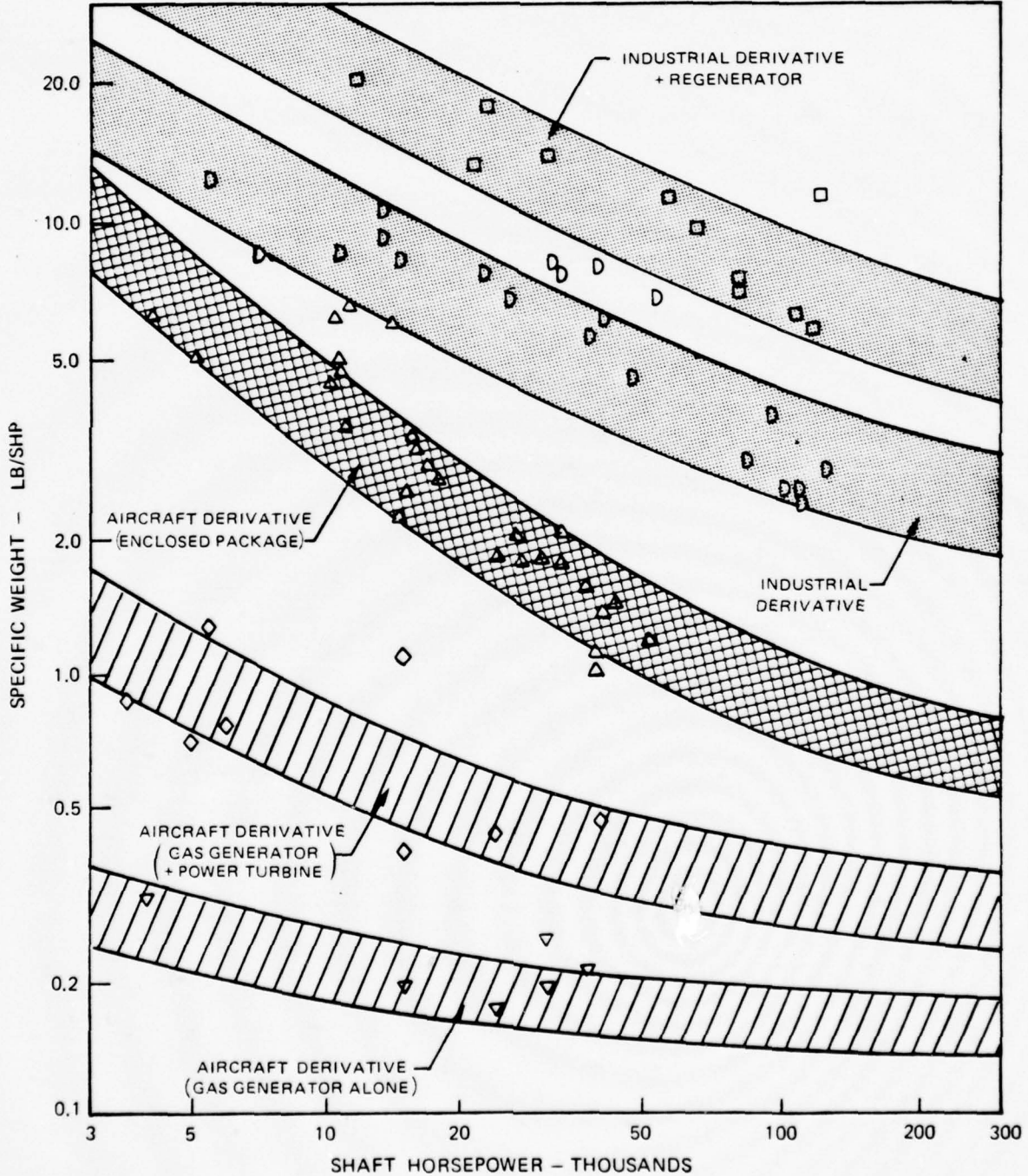

COMPARISON OF OPEN-CYCLE GAS TURBINE SPECIFIC VOLUMES

- △ AIRCRAFT DERIVATIVE
- INDUSTRIAL AND ACCESSORY
- ▽ AIRCRAFT DERIVATIVE w/o POWER TURBINE
- ◇ INDUSTRIAL
- ◇ AIRCRAFT DERIVATIVE w/o ENCLOSURE

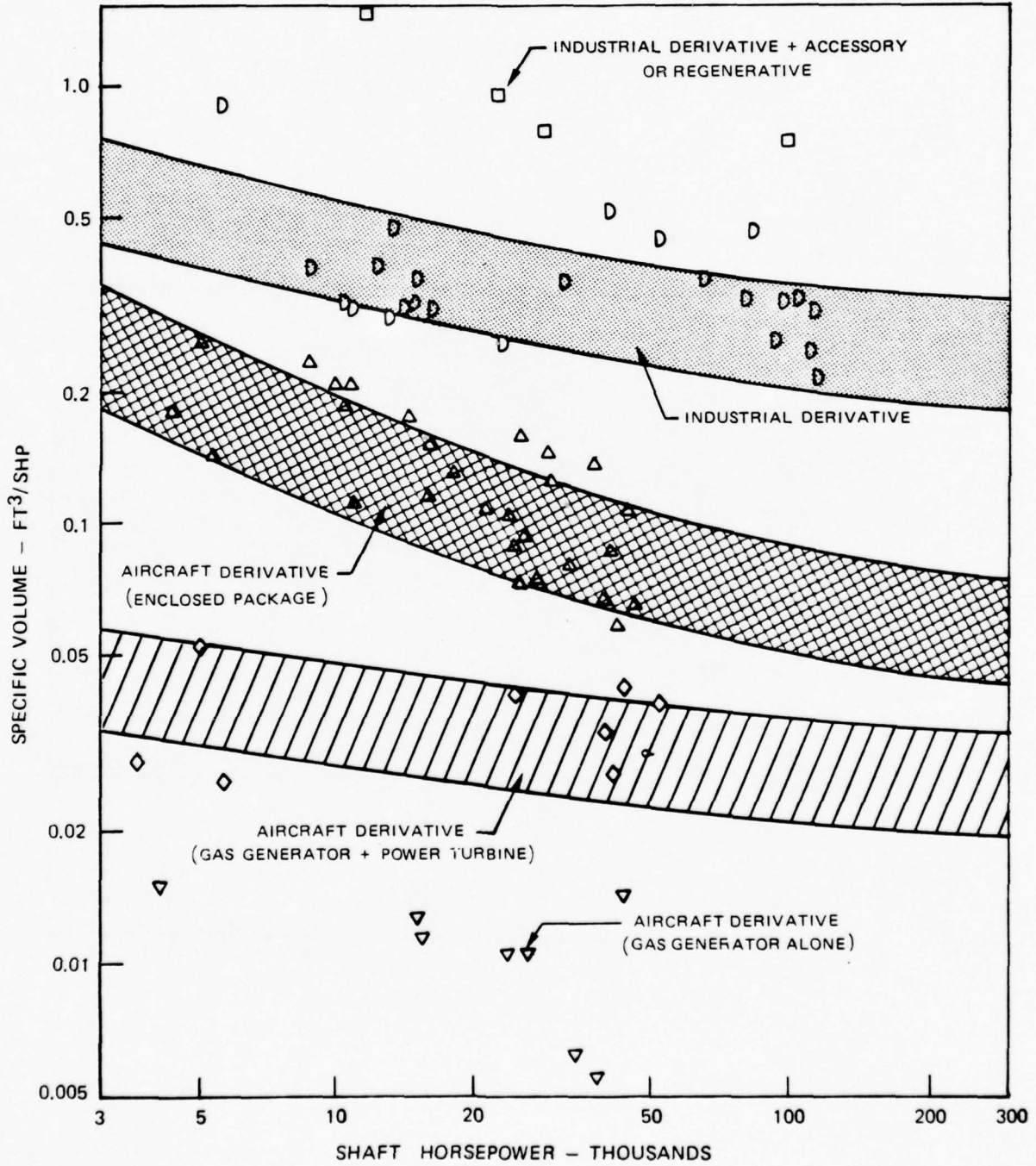

TYPICAL OCGT POWER TURBINE RPM

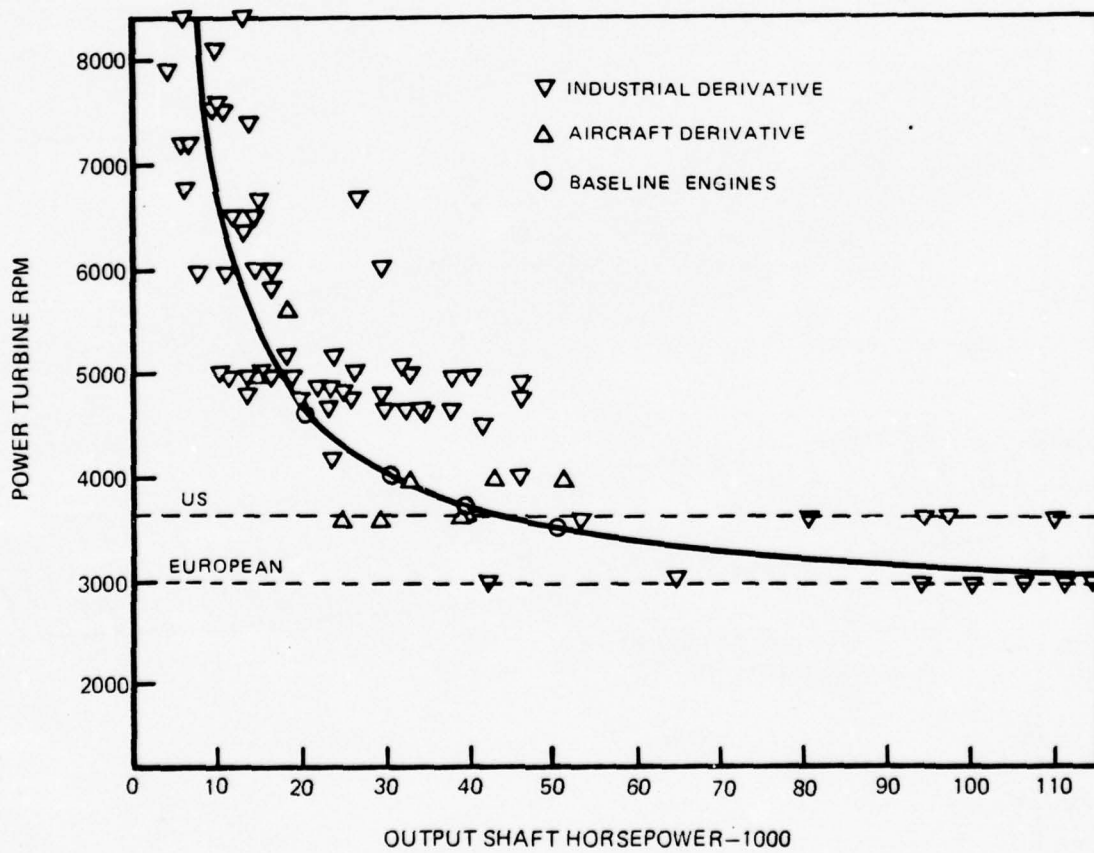

EFFECT OF SHAFT RPM ON OCGT POWER TURBINE WEIGHT

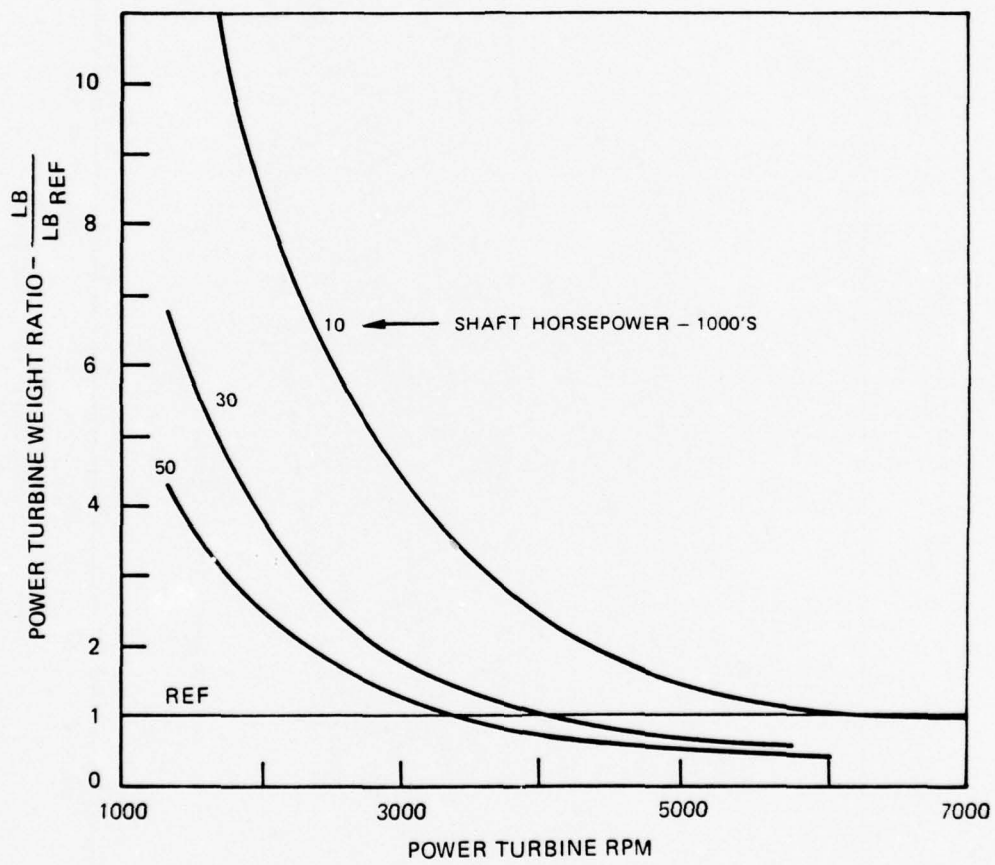

ENGINE UNIT CAPACITY AND SHAFT RPM

TURBINE INLET TEMP = 1500 F

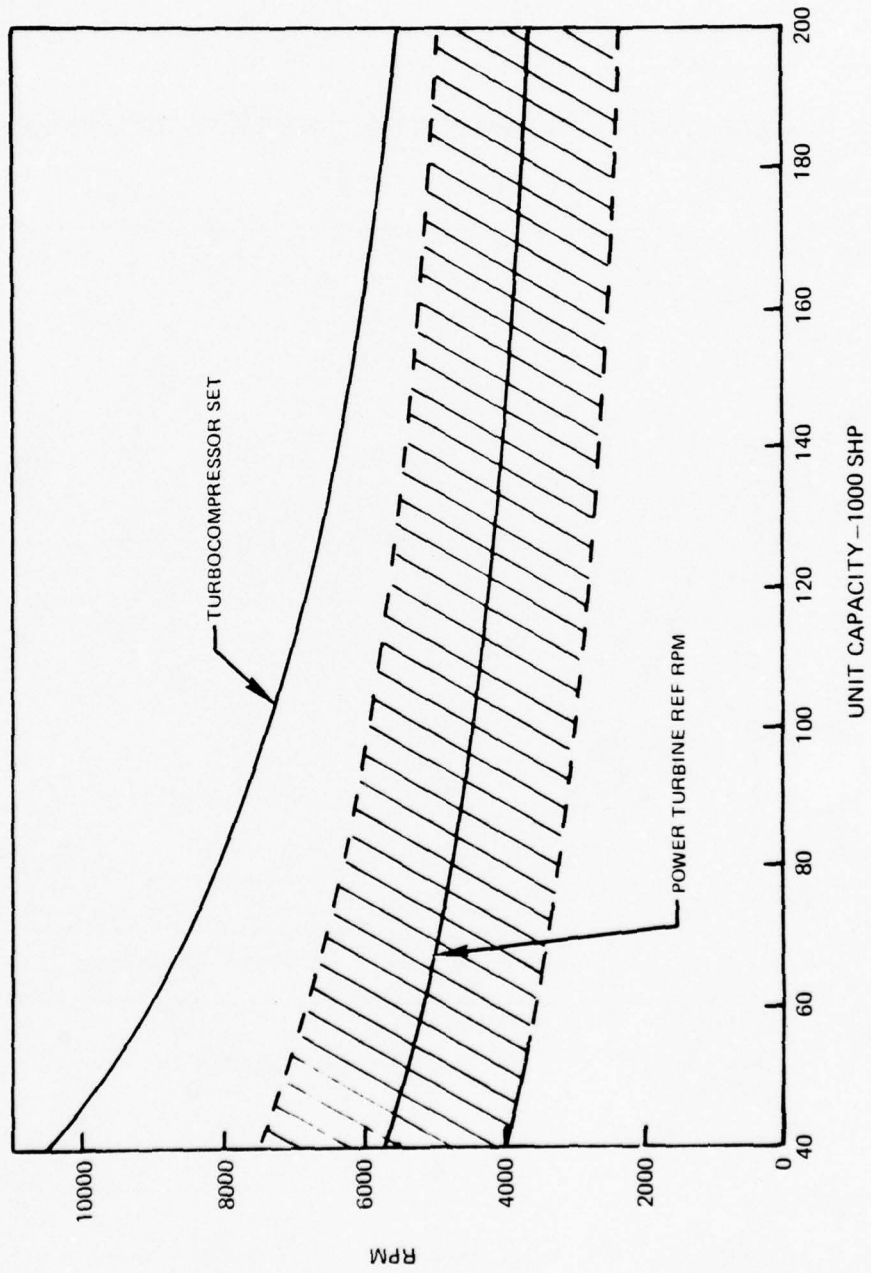

ESTIMATED TURBOMACHINERY SIZE FOR BASELINE CCGT SYSTEMS

TURBINE INLET TEMPERATURE = 1500F
CONFIGURATION II REFERENCE DESIGN

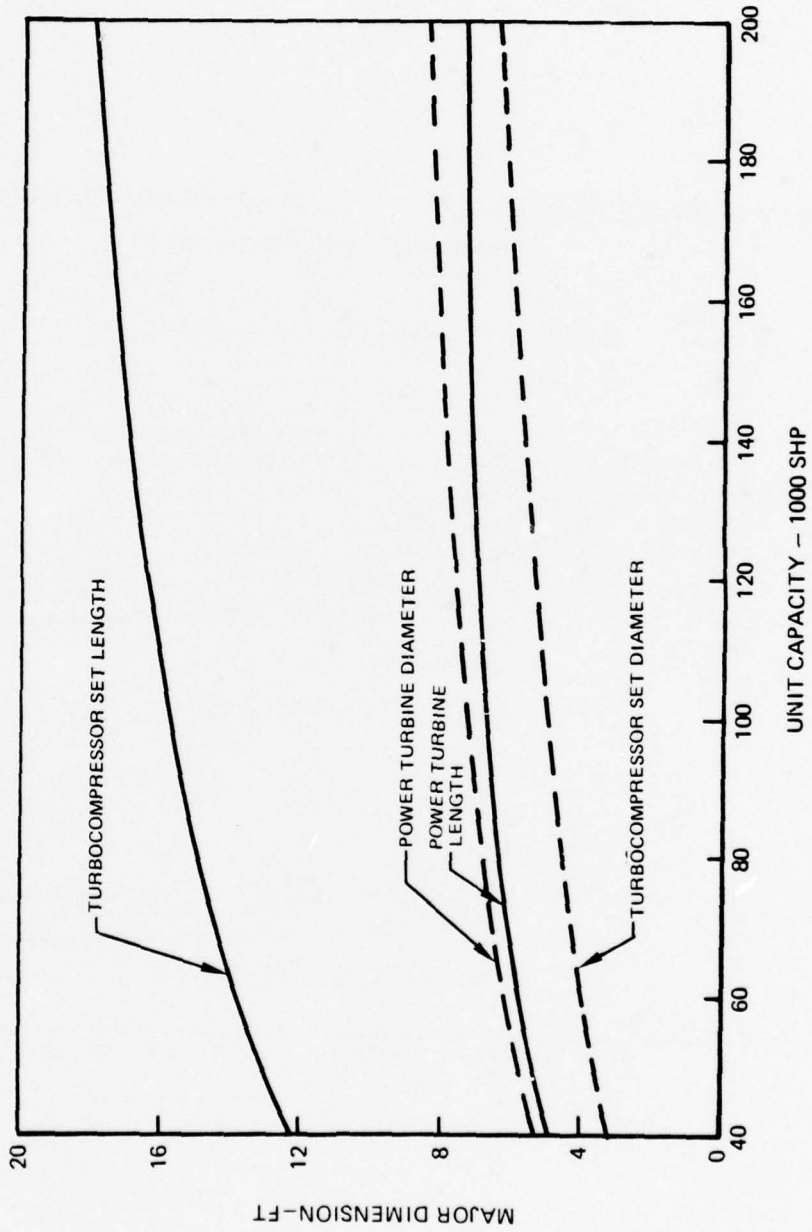

ESTIMATED BASELINE CCGT POWER CONVERSION SYSTEMS INSTALLED WEIGHT

TURBINE INLET TEMPERATURE = 1500F

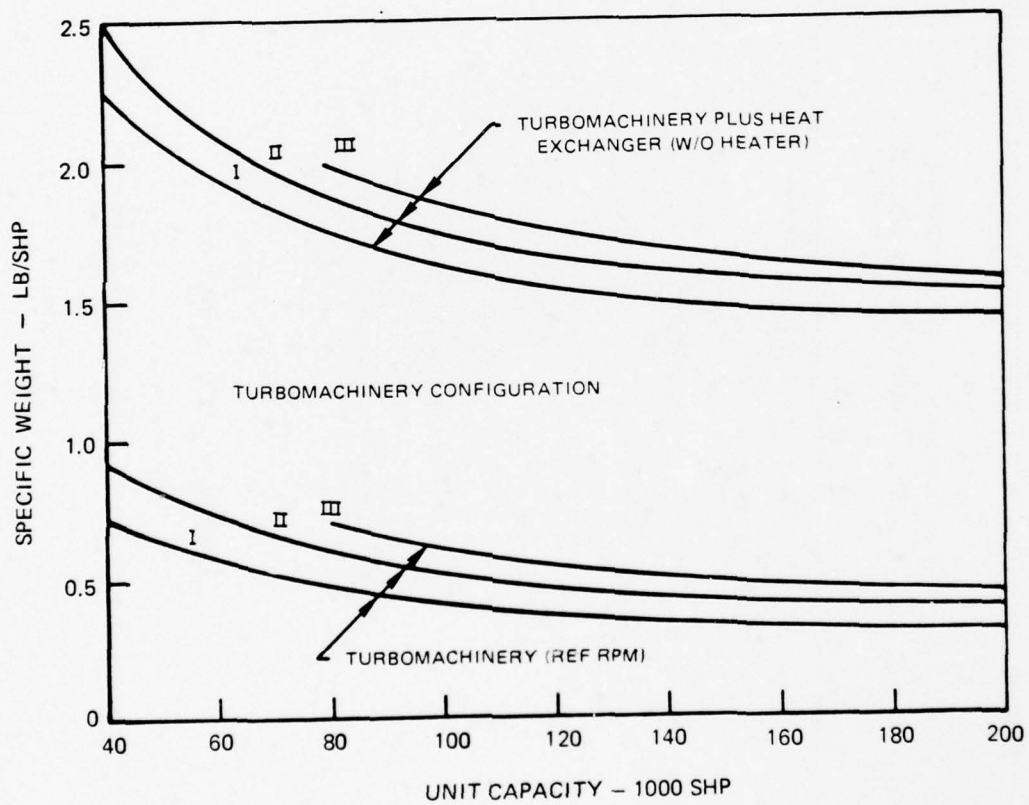

EFFECT OF SHAFT RPM ON CCGT POWER TURBINE SPECIFIC WEIGHT

TURBINE INLET TEMP = 1500F
TURBOMACHINERY CONFIGURATION II

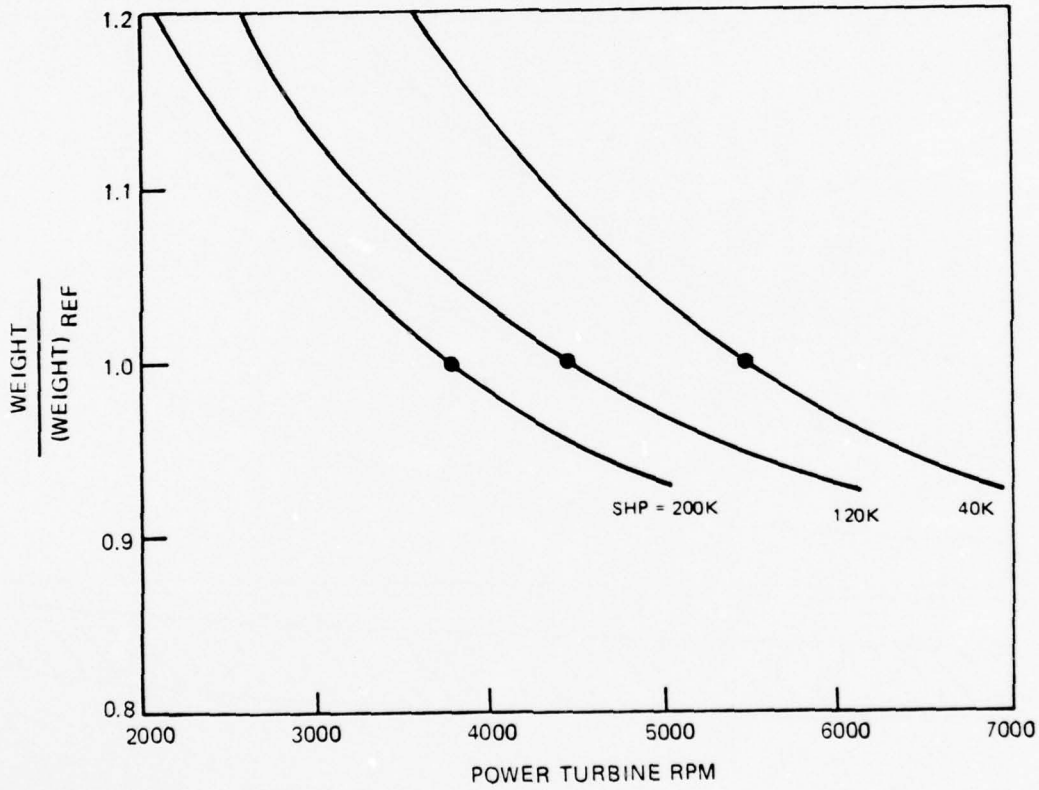

EFFECT OF TUBE SIZE ON REGENERATOR DIMENSIONS

TURBINE INLET TEMPERATURE = 1500F
POWER OUTPUT = 80,000 SHP

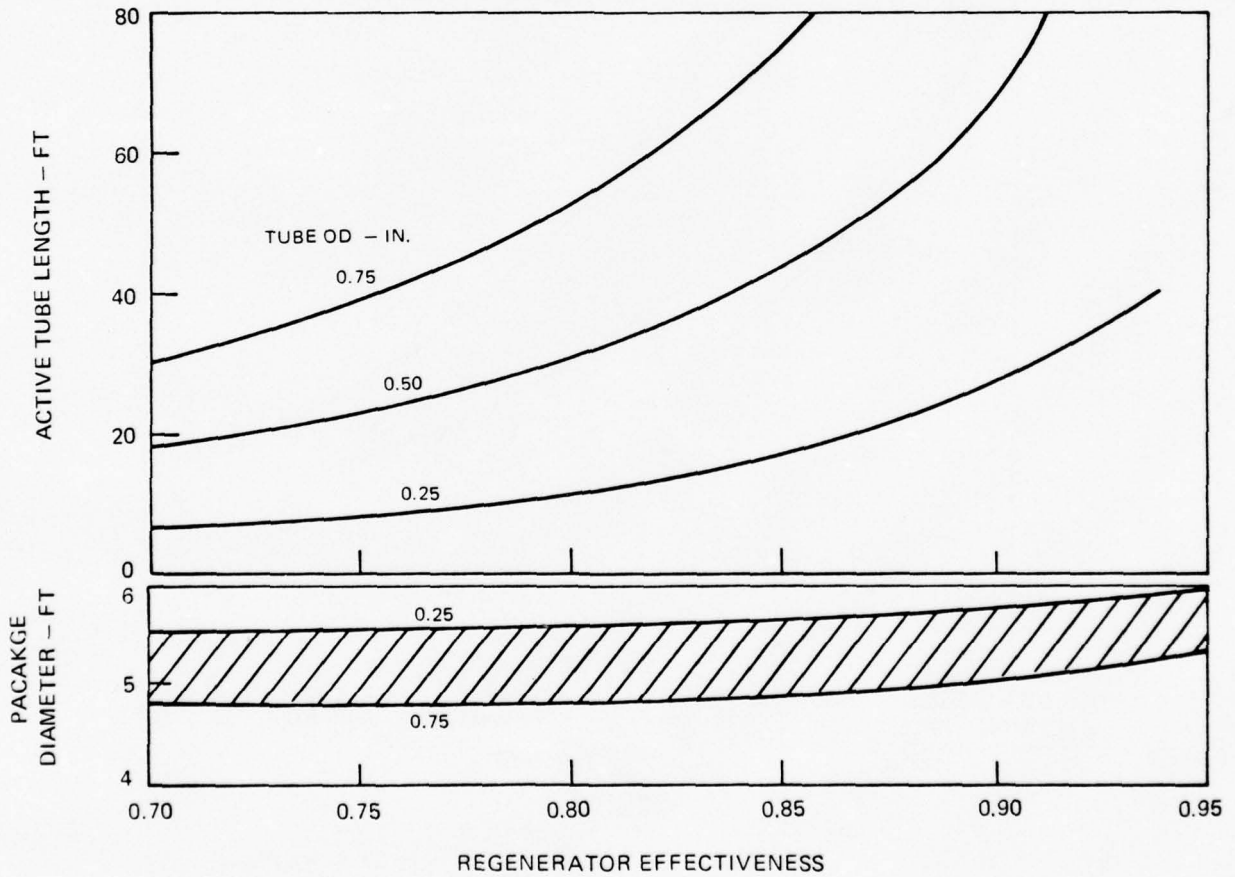

EFFECT OF TUBE SIZE ON REGENERATOR SPECIFIC WEIGHT

TURBINE INLET TEMP = 1500 F
POWER OUTPUT = 80,000 SHP
SUPPORTING STRUCTURE WEIGHT INCLUDED

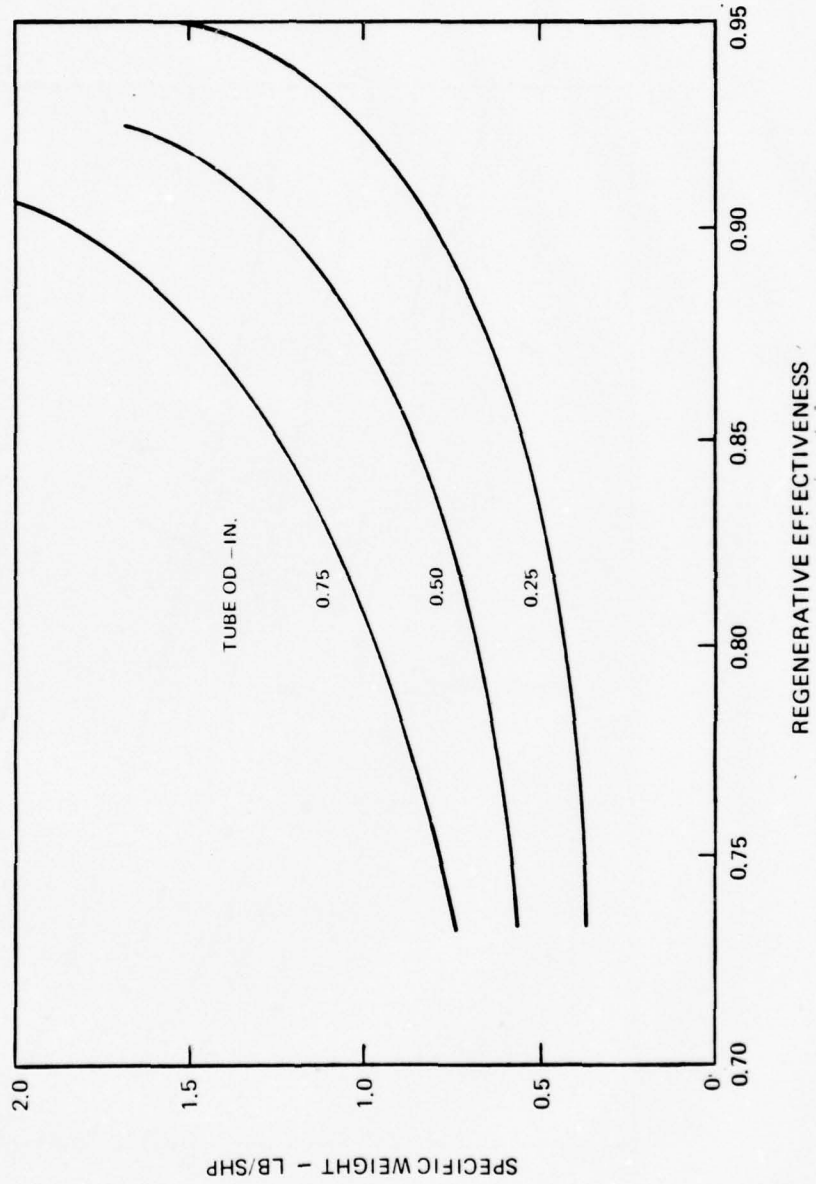

ESTIMATED HEAT EXCHANGER SIZE FOR BASELINE CCGT SYSTEMS

TURBINE INLET TEMPERATURE = 1500F
TUBE OD = 0.25 INCHES

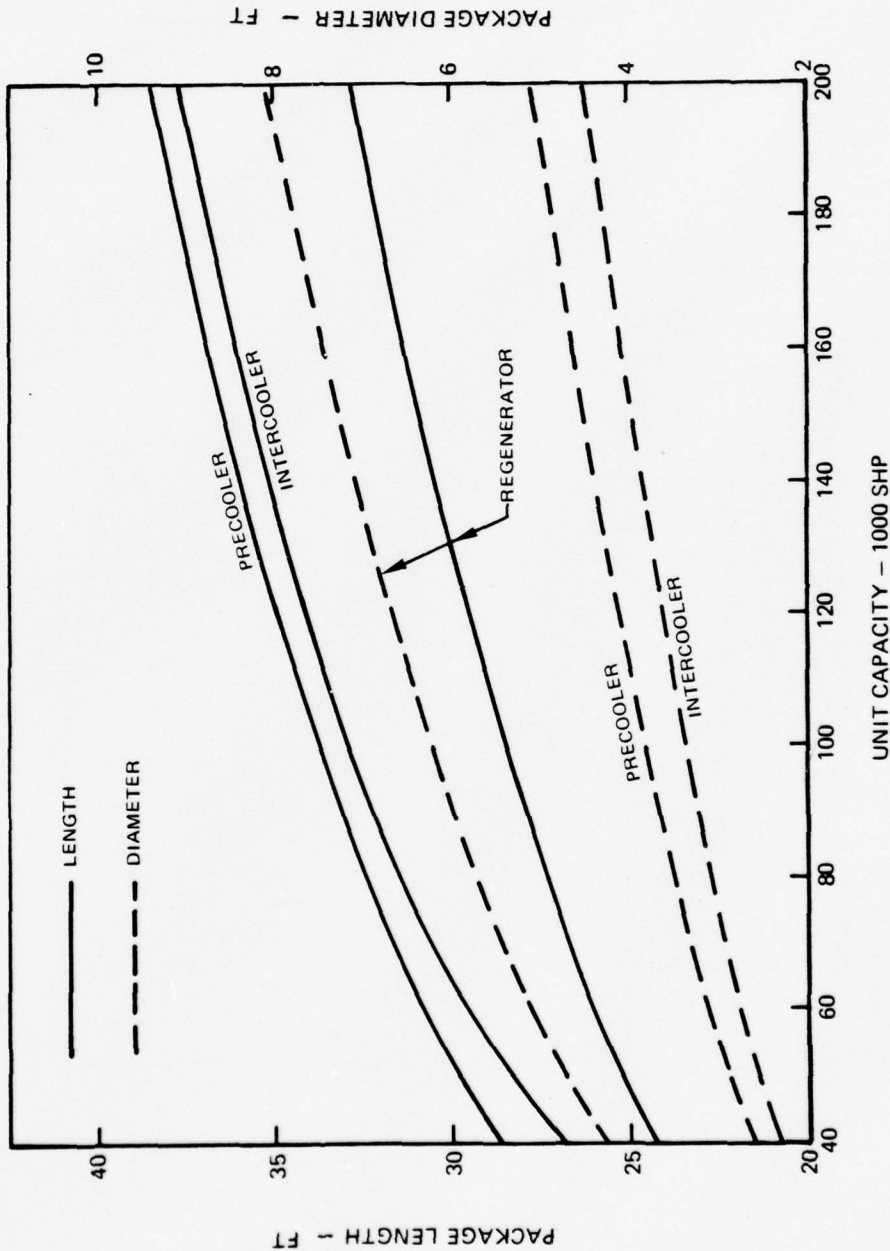

ESTIMATED HEAT EXCHANGER WEIGHT FOR BASELINE CCGT SYSTEMS

TURBINE INLET TEMPERATURE = 1500 F
TUBE OD = 0.25 INCHES

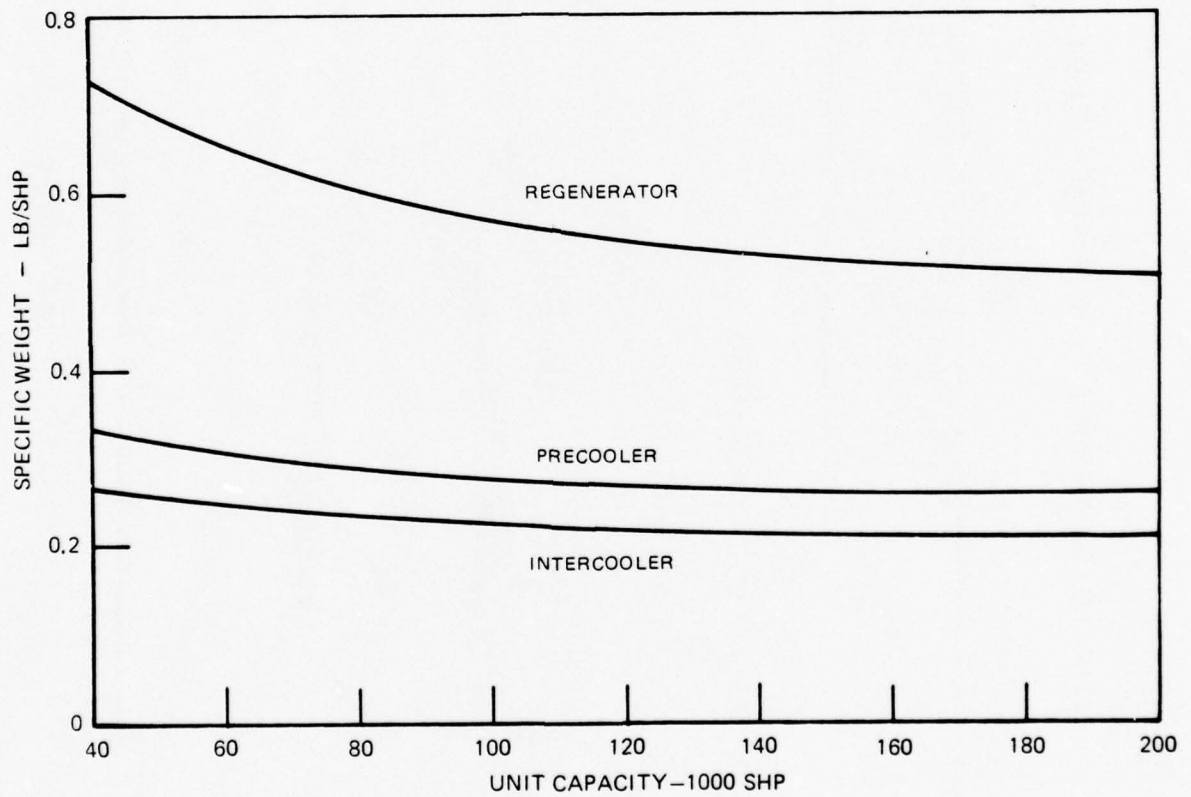

ESTIMATED OCGT ENGINE PLUS GEARBOX WEIGHT

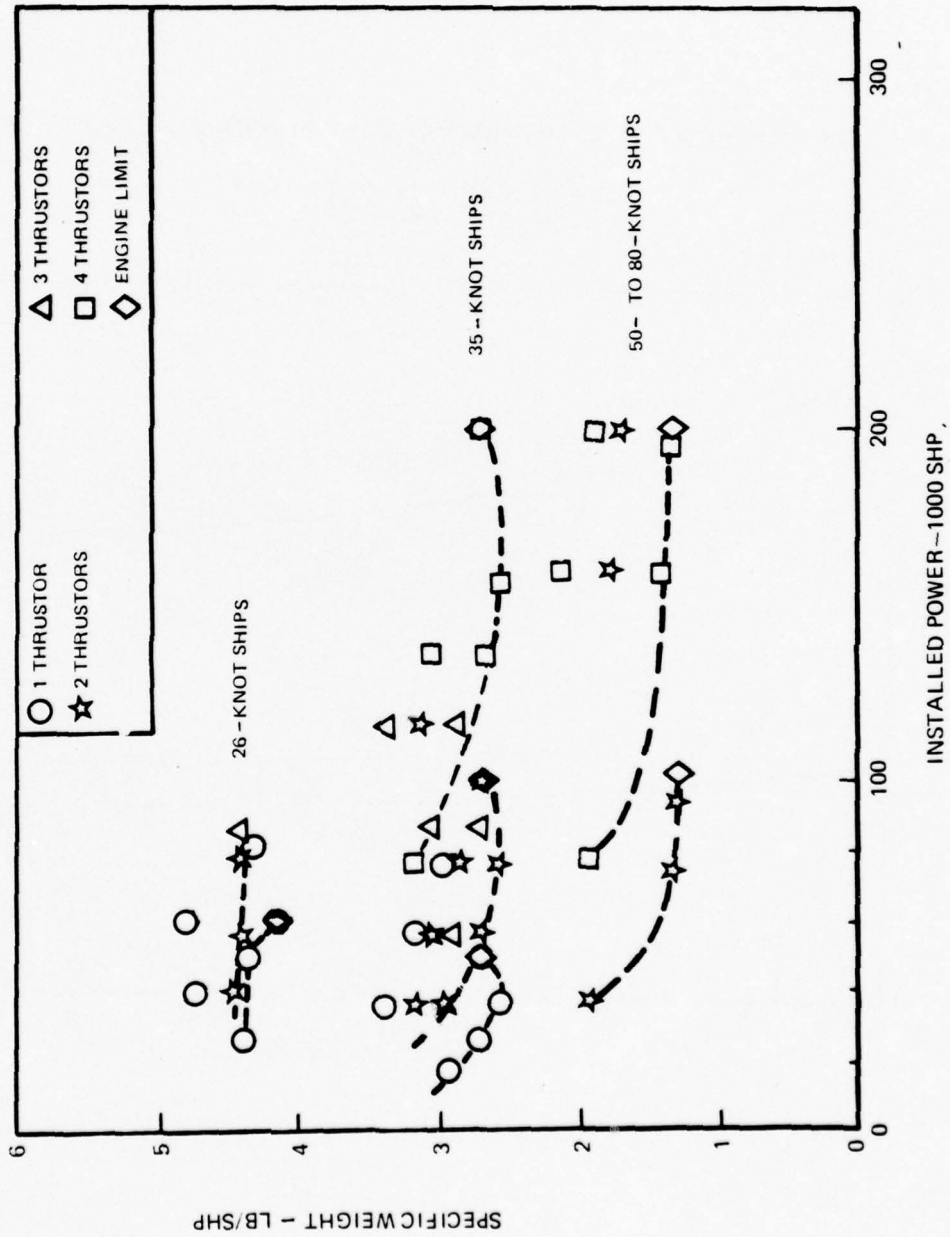

ESTIMATED CCGT POWER CONVERSION SYSTEMS PLUS GEARBOX WEIGHT

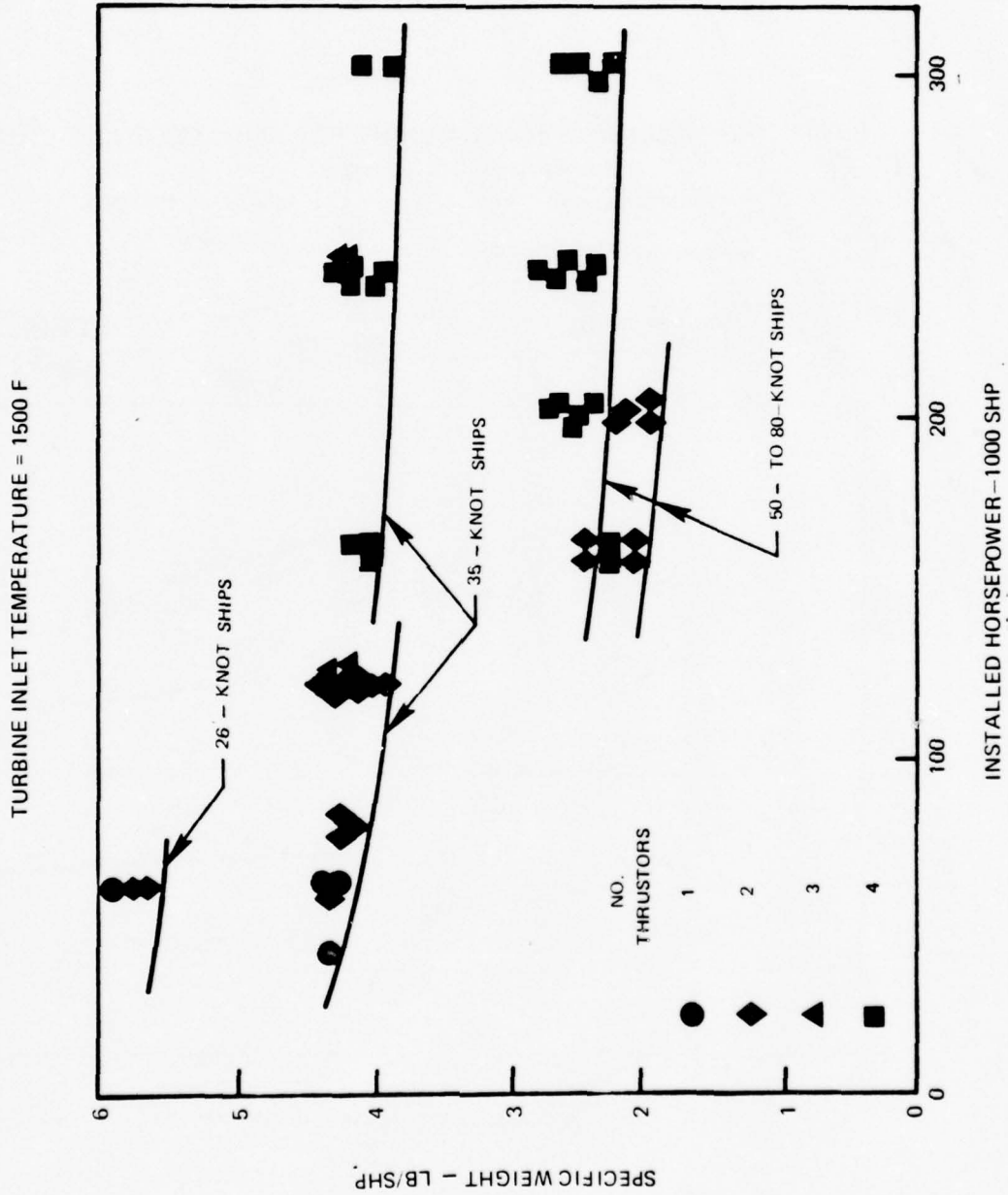

ESTIMATED MINIMUM SPECIFIC WEIGHT FOR BASIC OCGT ARRANGEMENTS

ENGINE + GEARBOX WEIGHT

○ THRUSTOR LIMIT

R = REVERSING GEARBOX

◇ OPEN CYCLE ENGINE LIMIT

REQUIRED

ARRANGEMENT

CODE: B =

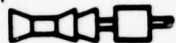

C =

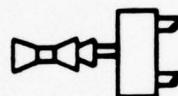

E =

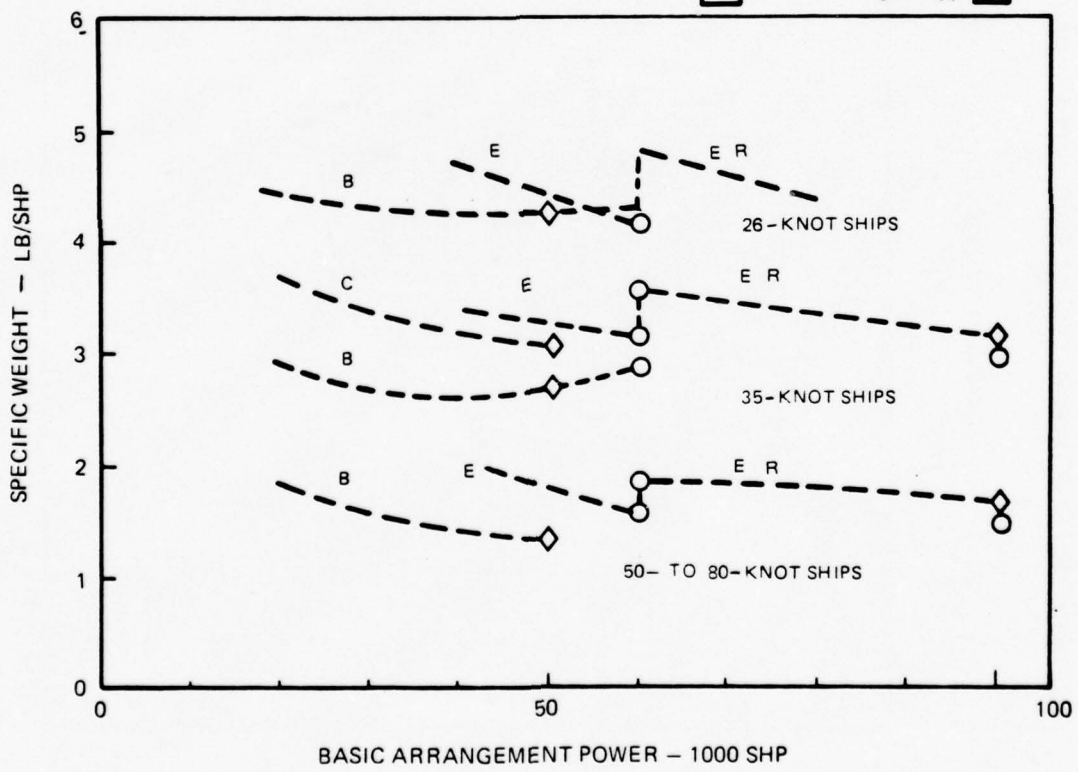
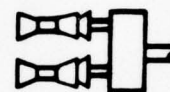

**ESTIMATED MINIMUM SPECIFIC WEIGHT FOR CCGT
BASIC ARRANGEMENTS**

ENGINE (W/O HEATER) + GEAR BOX WEIGHT

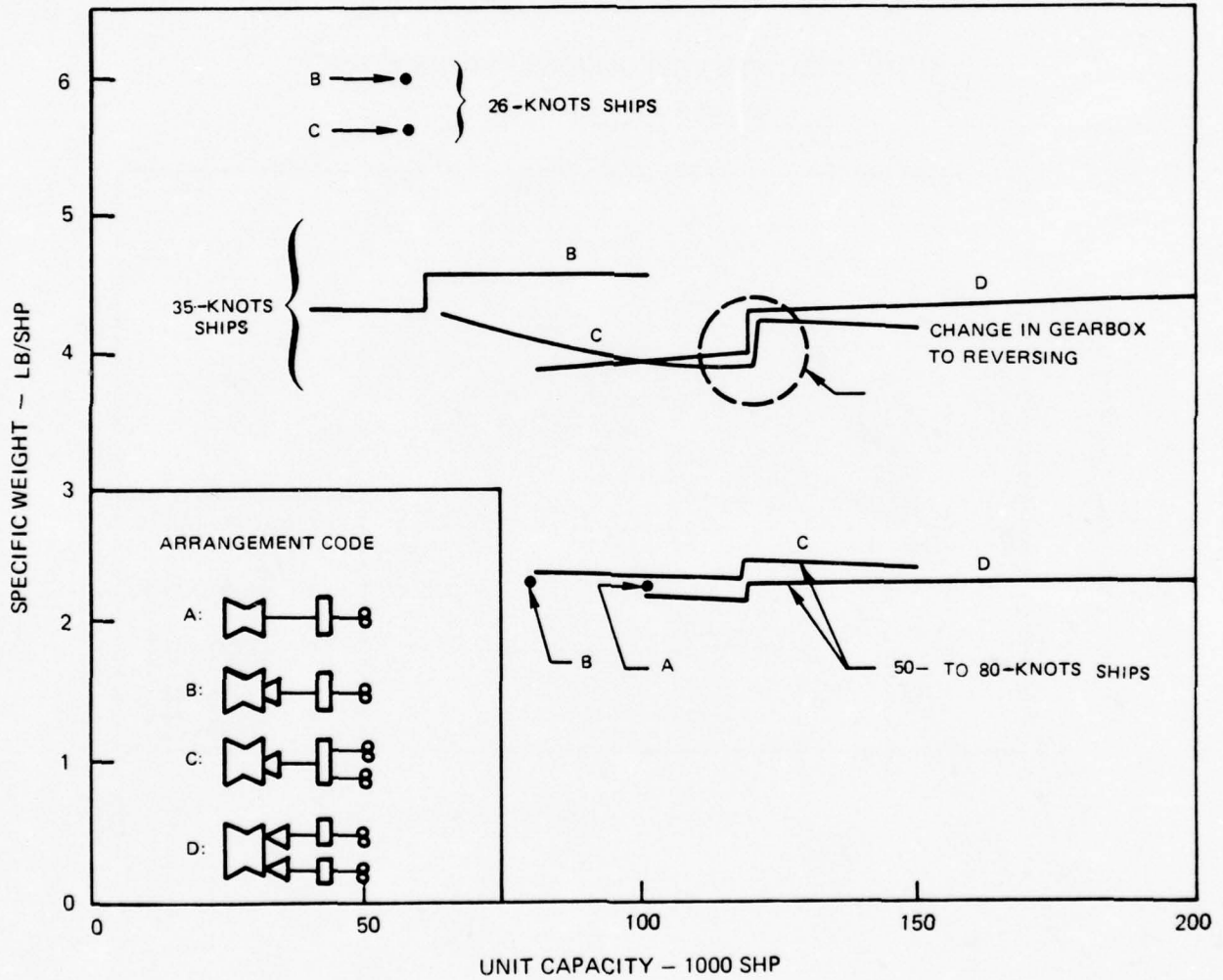

ESTIMATED OCGT PROPULSION SYSTEMS WEIGHT
ENGINE + GEARBOX + SHAFTS

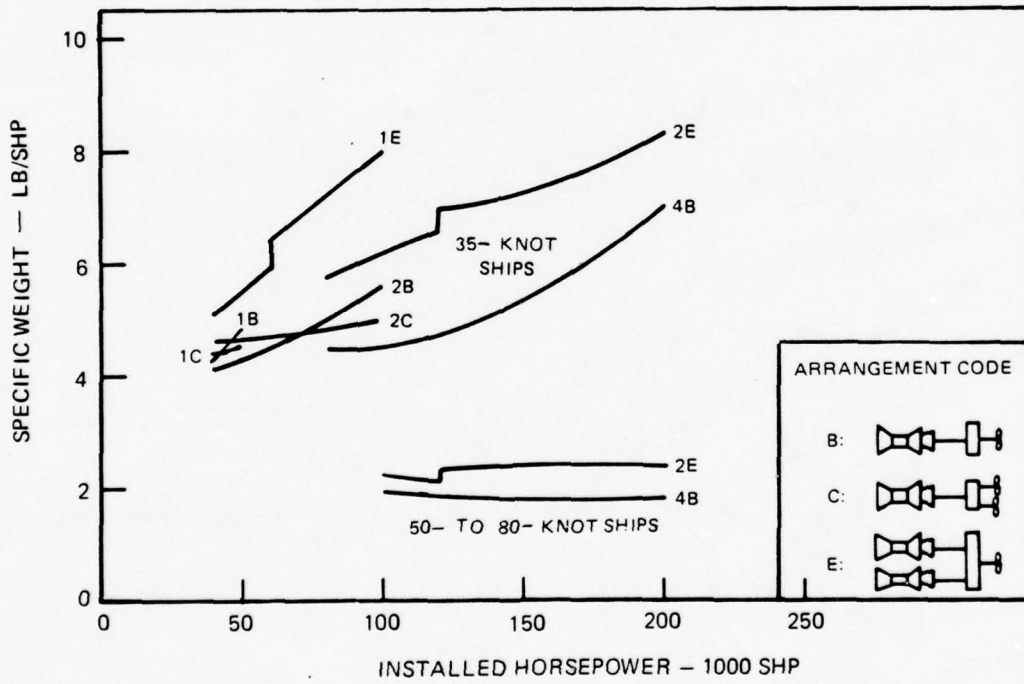

ESTIMATED CCGT PROPULSION SYSTEM WEIGHT

ENGINE (W/O HEATER)+ GEAR BOX + SHAFTS

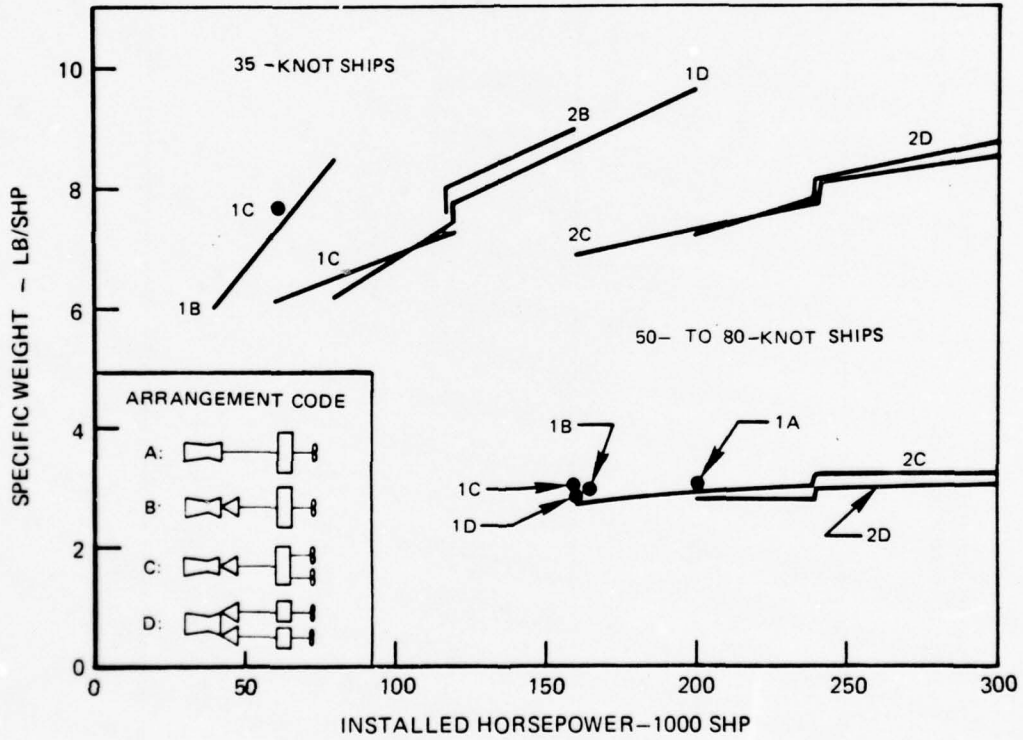

COMPARISON OF ENGINE PLUS FUEL SPECIFIC WEIGHT FOR CONVENTIONAL DESTROYERS

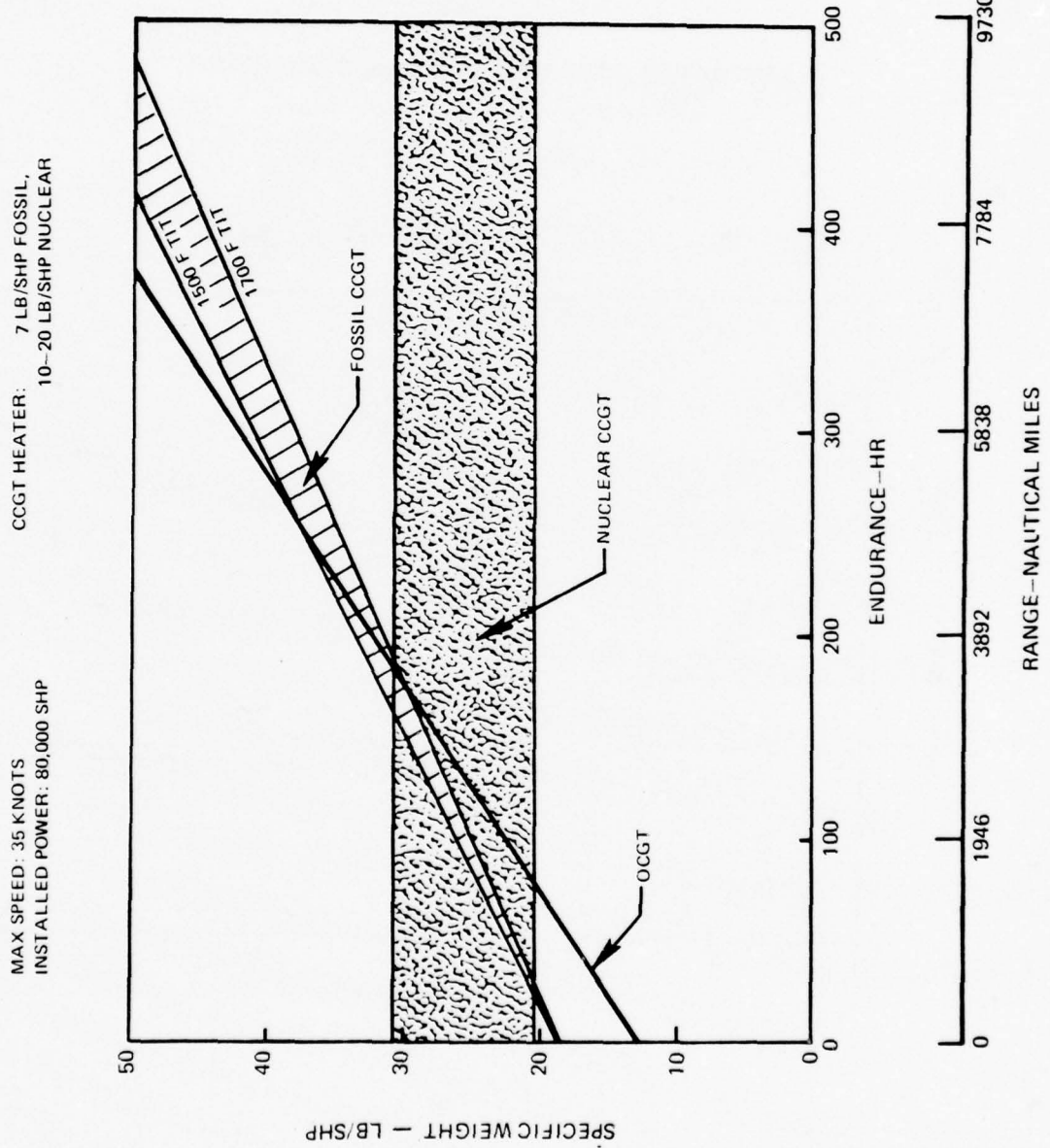

COMPARISON OF ENGINE PLUS FUEL SPECIFIC WEIGHT FOR HIGH - SPEED DESTROYERS

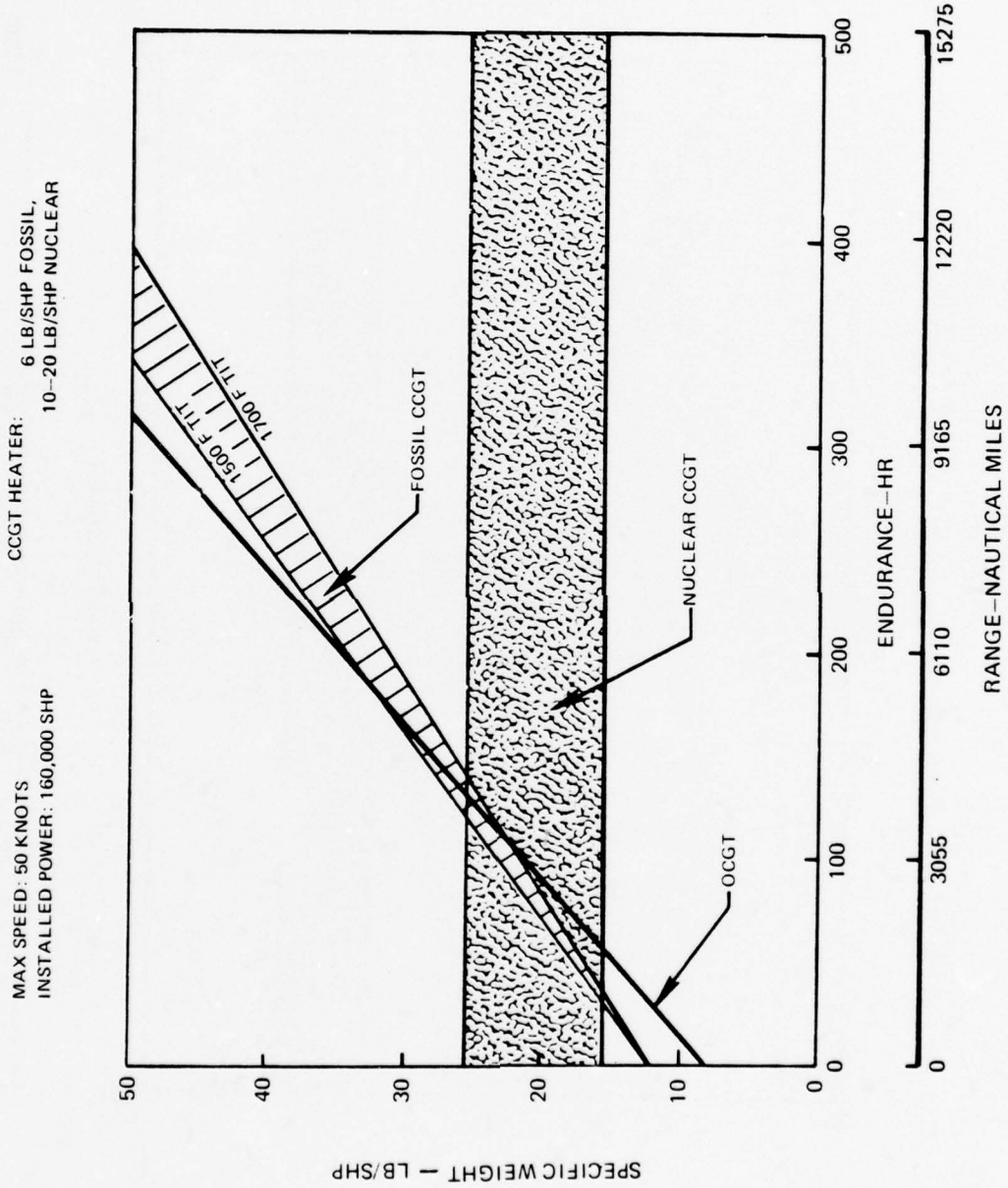

COMPARISON OF ENGINE PLUS FUEL SPECIFIC WEIGHT FOR HIGH PERFORMANCE SHIPS

MAX SPEED: 80 KNOTS
INSTALLED POWER: 200,000 SHP

CCGT HEATER: 7 LB/SHP FOSSIL,
10-20 LB/SHP NUCLEAR

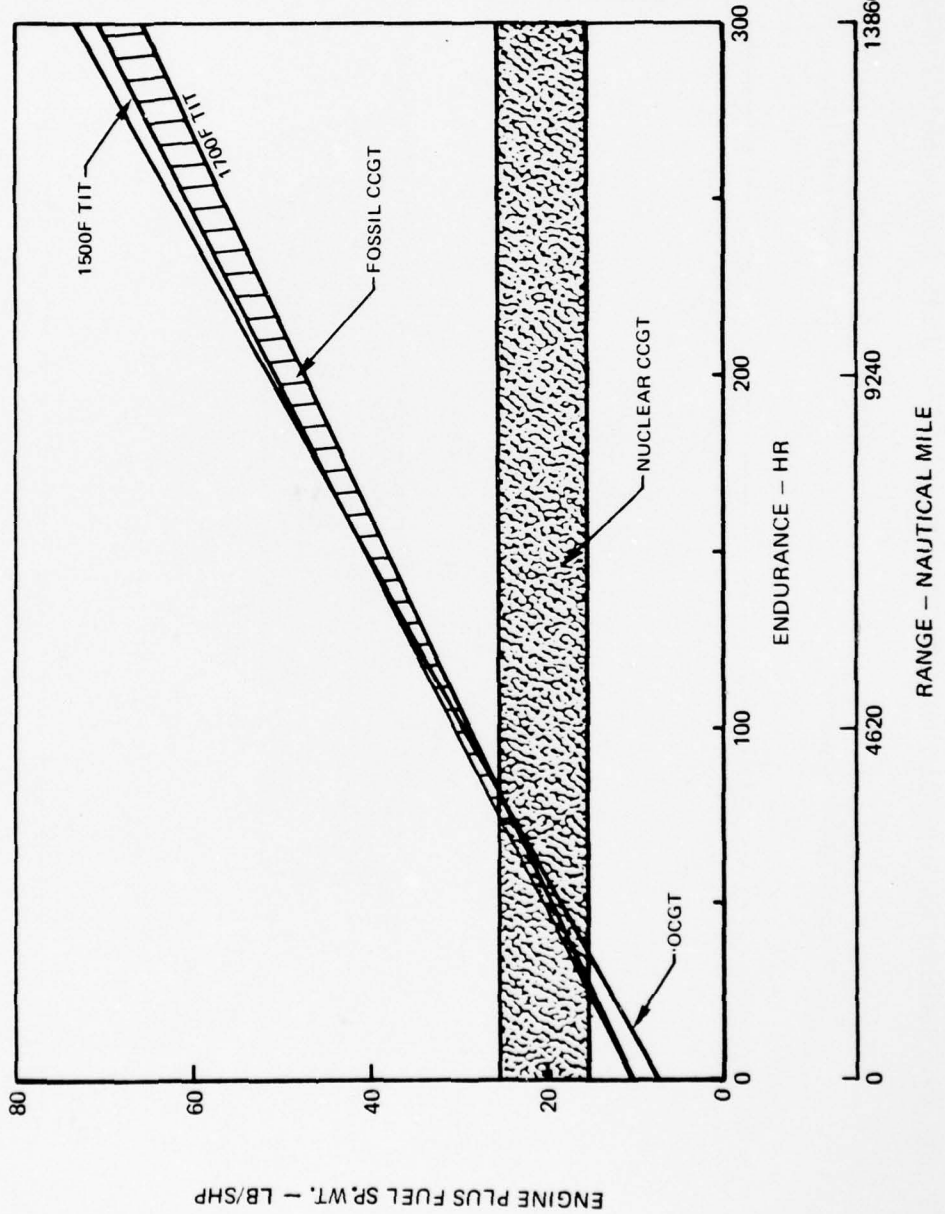

COMPARISON OF ENGINE PLUS FUEL SPECIFIC WEIGHT FOR CRUISE

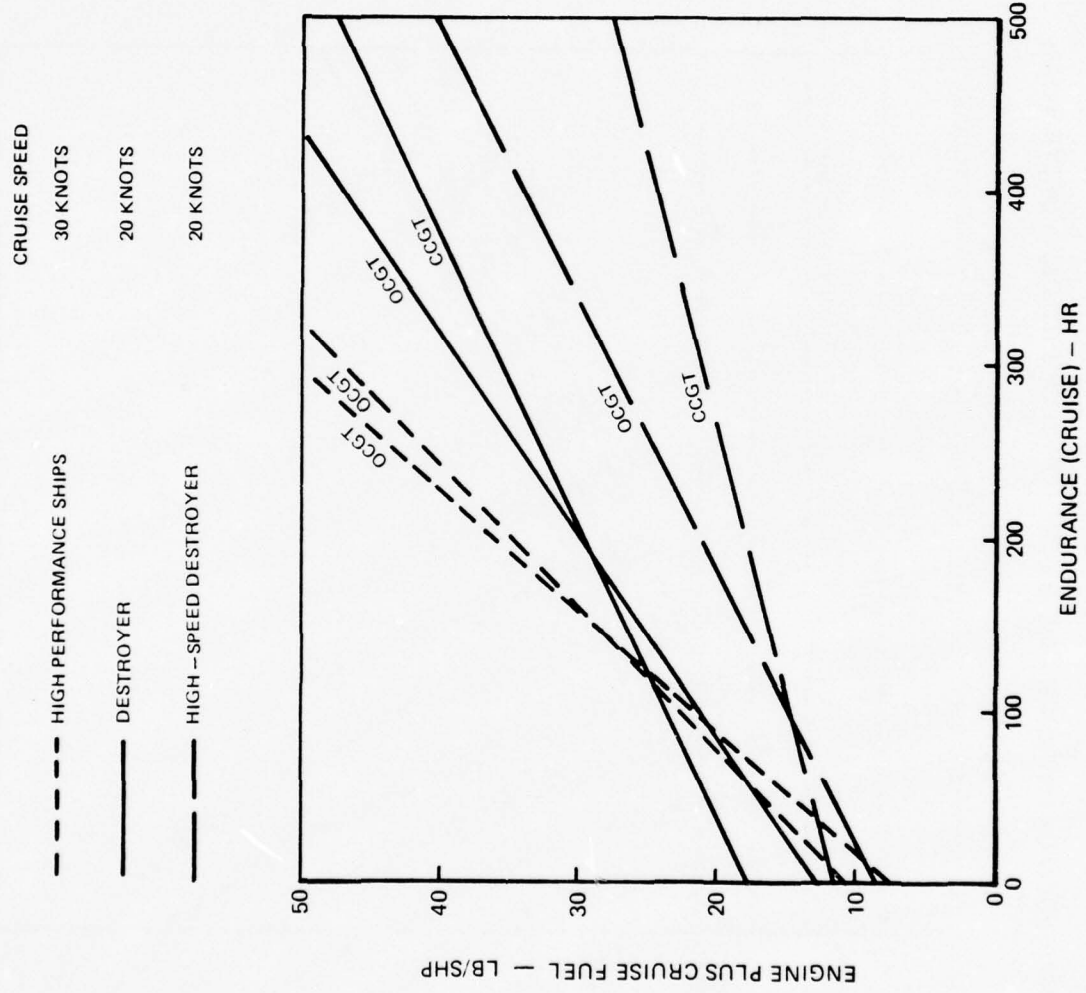

COMPARISON OF PAYLOAD CAPABILITY FOR CONVENTIONAL DESTROYERS

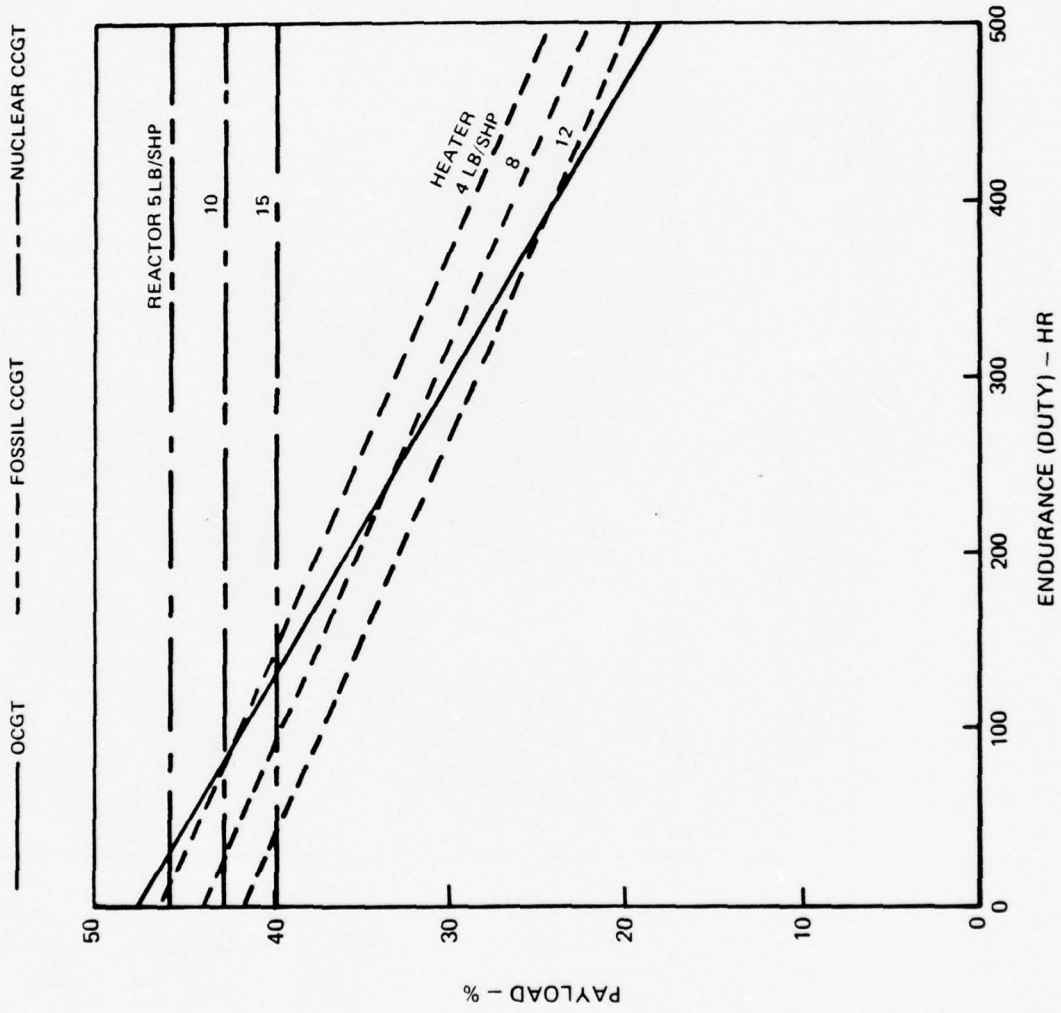

COMPARISON OF PAYLOAD CAPABILITY FOR HIGH-SPEED DESTROYERS

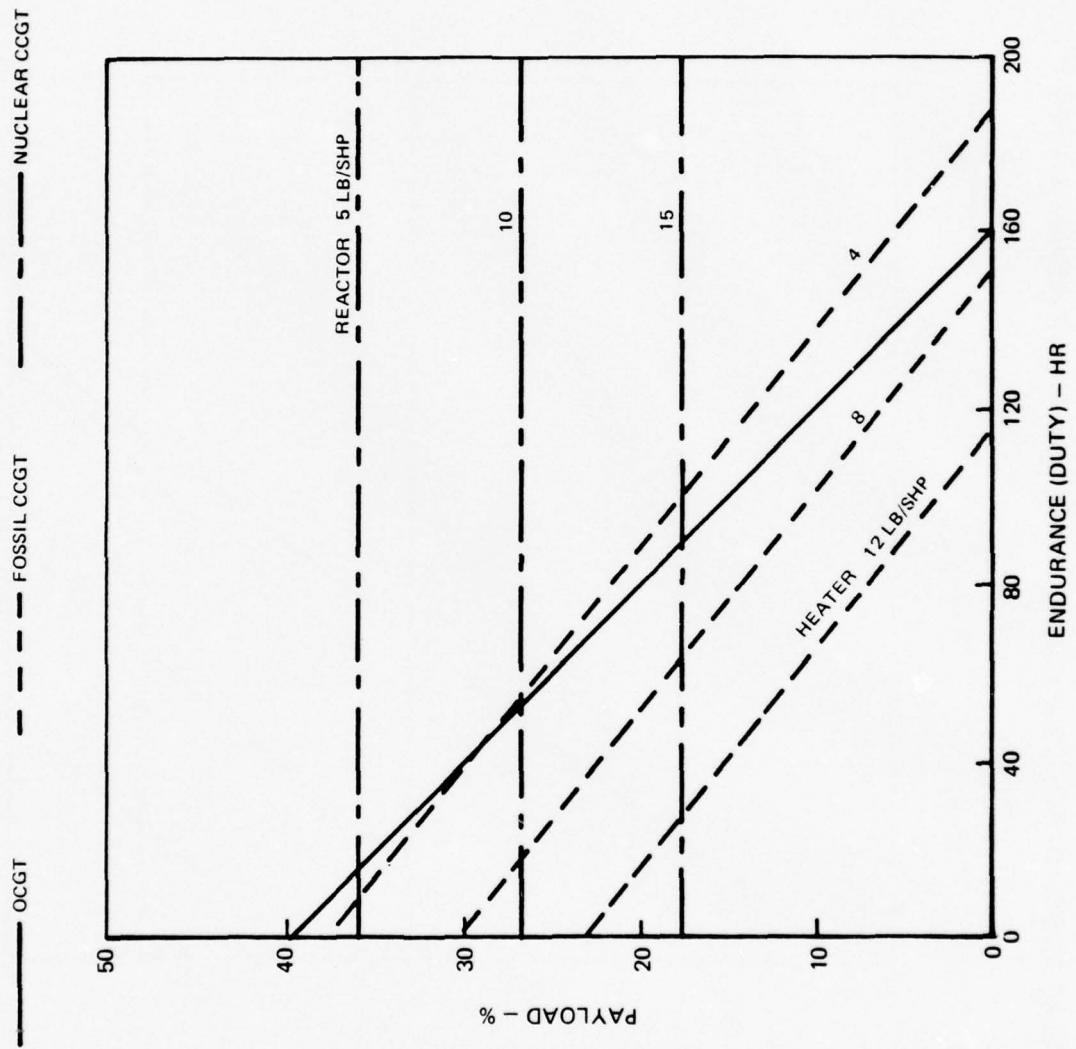

COMPARISON OF PAYLOAD CAPABILITY FOR HIGH PERFORMANCE SHIPS

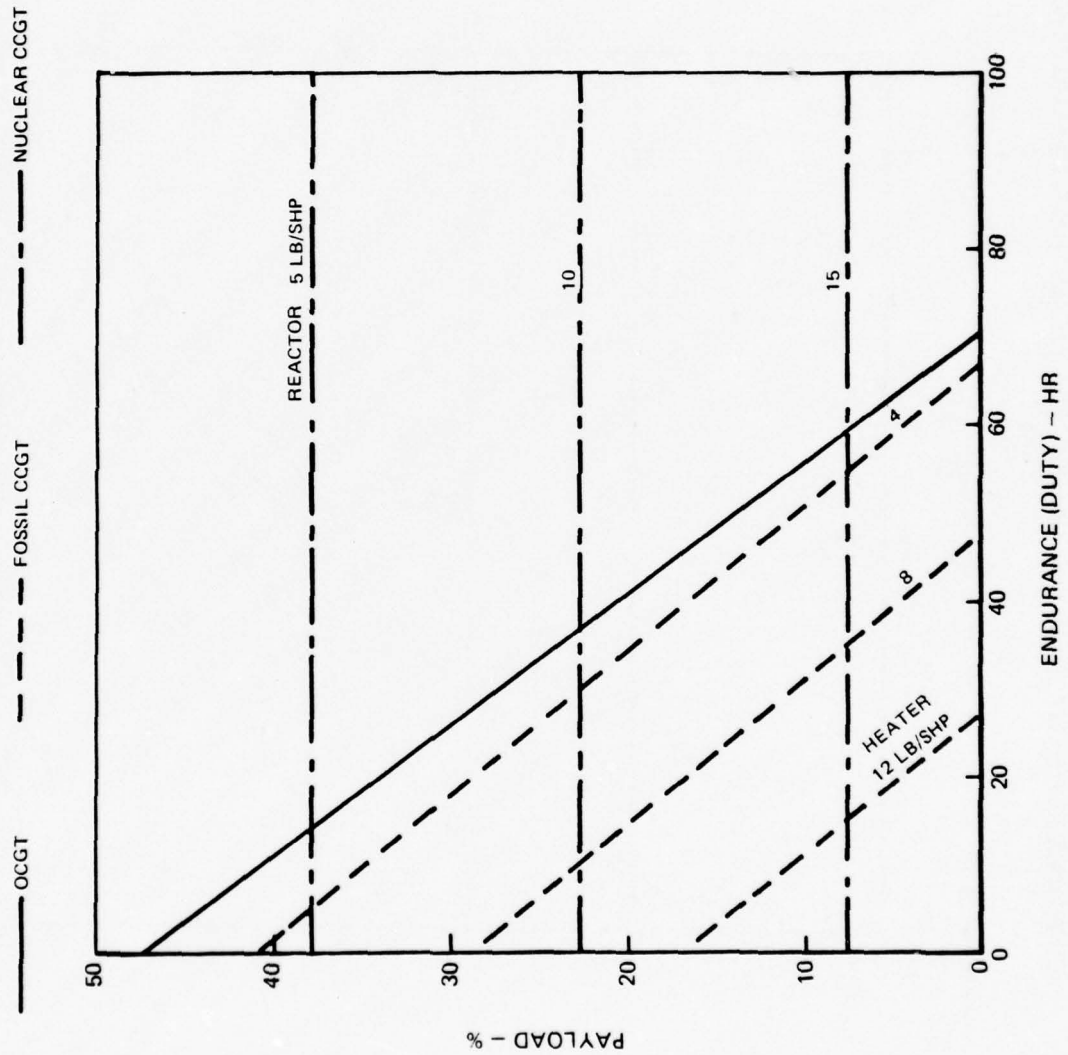

ESTIMATED PAYLOAD CAPABILITY FOR SELECTED GAS TURBINE POWERED NAVAL SHIPS

FOSSIL HEATER SPECIFIC WEIGHT : 4 - 8 LB/SHP

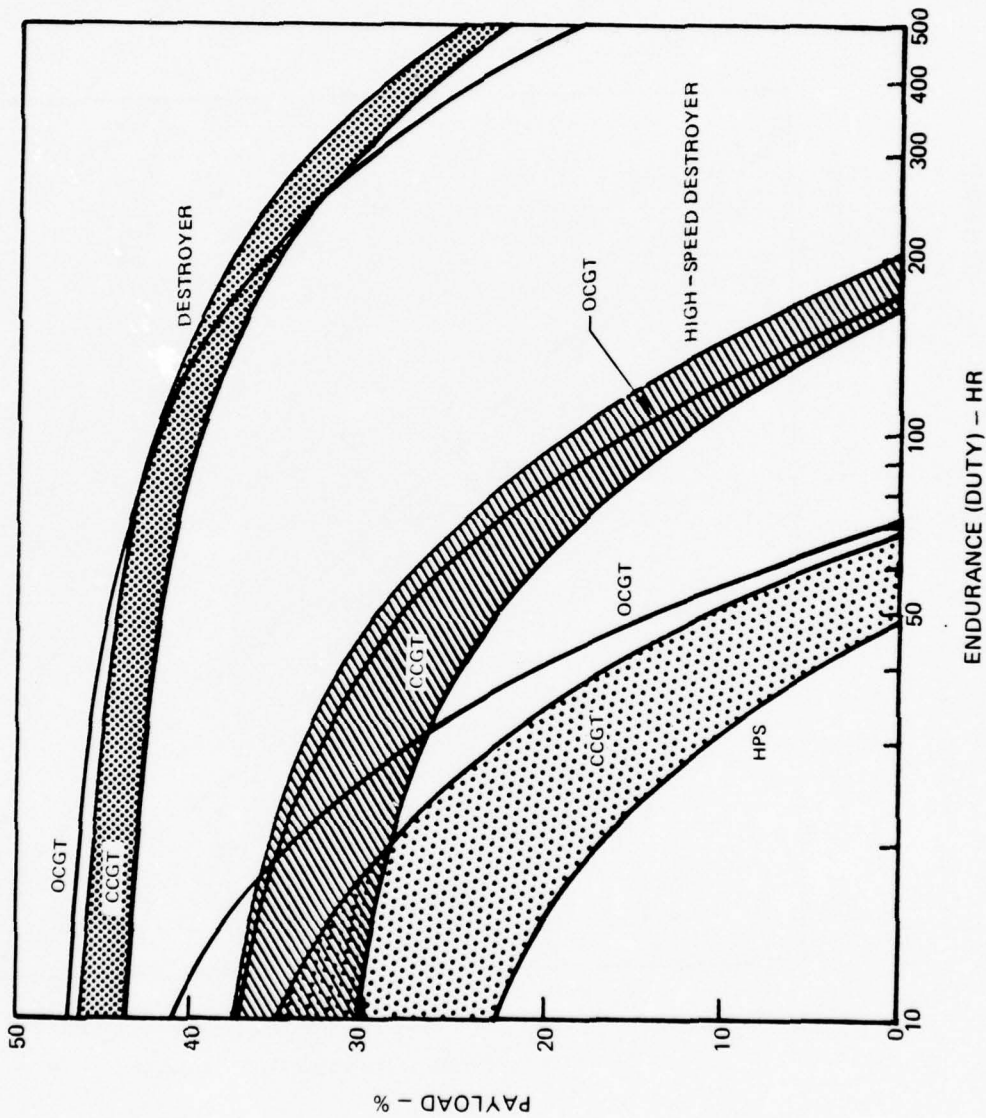

ALLOWABLE CCGT HEAT SOURCE SPECIFIC WEIGHT TO YIELD
OCGT PROPULSION SYSTEM PAYLOAD CAPABILITIES

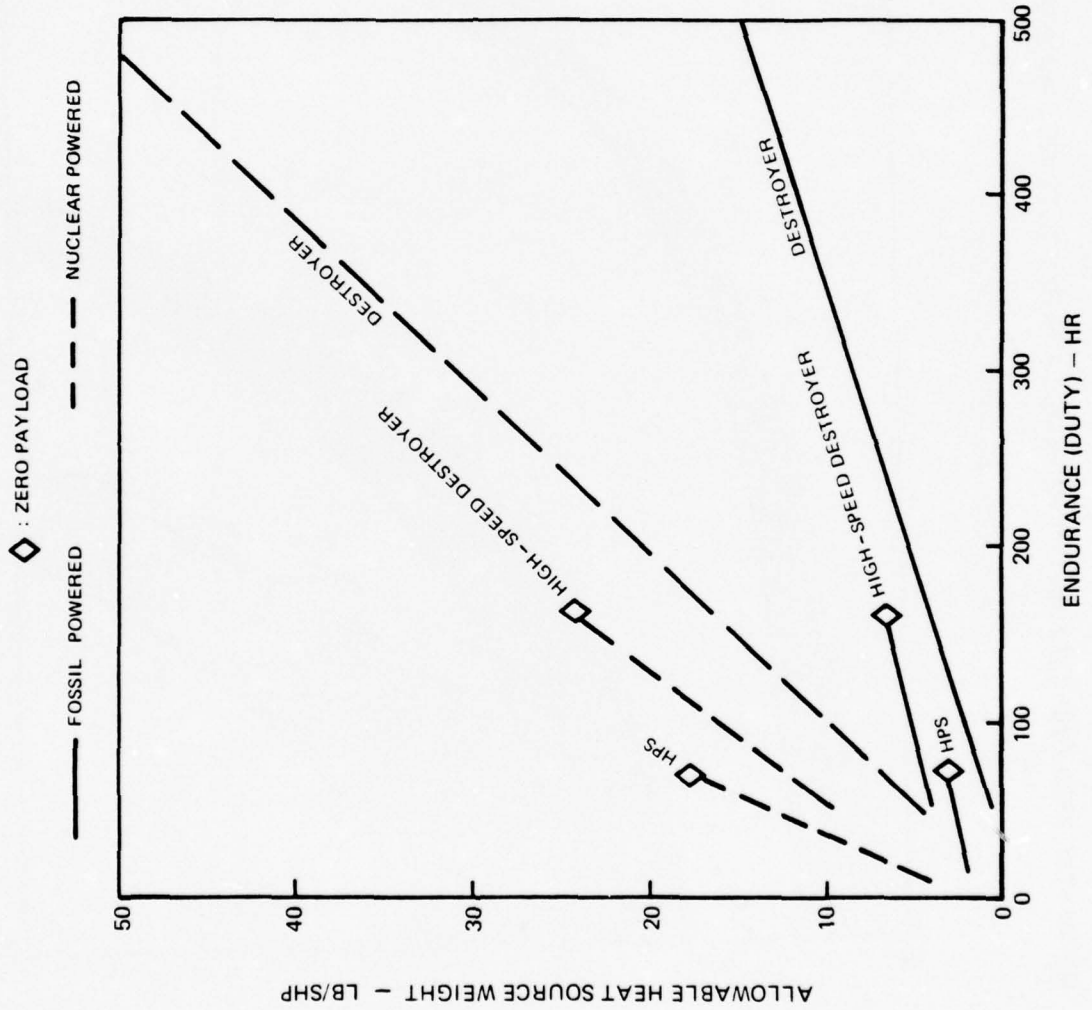

SECTION IV

PRELIMINARY ENGINEERING COST ANALYSIS

Information critical to a realistic cost evaluation of the open- and closed-cycle gas turbine engines, such as size, structure, materials, weight, arrangement, operating conditions, and layout has been investigated. Fabrication and operational requirements were reviewed to identify any unusual methods or techniques that must be used. The methodologies used to estimate the cost of the power conversion systems, transmission system, components, thrusters, and fuel are described. The estimated power conversion system costs for all baseline engines and the capital cost of propulsion system equipment for the selected ship types are presented. In addition, a discussion of the methodologies related to estimates made for system fuel costs is included in this section.

Significant Cost Factors

Schematic diagrams and drawings have been constructed to denote the flow of energy from fuel to thrusters and to establish general layout concepts for the engines as well as the total propulsion systems, as installed on the ships considered. Table VI-1 summarizes many of the factors which have been noted as having a significant effect on cost. Physical size and weight of the turbomachinery is not considered to be a handling problem in the ships where open-cycle engines up to 50,000 hp are considered, as long as no more than four engines are installed. At the same physical size as that of a 50,000 shp open-cycle engine, a closed-cycle turbomachine could develop over 150,000 shp; therefore, no costly handling, fabrication, or layout problems are anticipated. The dimensions of a closed-cycle engine developing 200,000 shp is estimated to be 26-feet long and 8.5-feet maximum diameter. These dimensions are smaller than for the largest presently available open-cycle engine. Ducting for the closed-cycle is expected to be less cumbersome than ducting for open-cycle engines due to reduced requirements for air flow, filtration, and sound attenuation, as well as shorter runs between equipment.

The environment for shipboard installations has an effect on costs of both open- and closed-cycle engines. Requirements for filtration and sound proofing of inlet and exhaust systems were considered for the open-cycle engines. Furthermore, provisions to withstand severe shock loading in the supporting structure must be considered for both open- and closed-cycle systems. The turbomachinery component materials are chosen as a function of stress and temperature to provide an equivalent replacement life (ERL)* of at least 10,000 hours for the open-cycle systems and

*ERL represents the hours of operation during which the cumulative cost of the components replaced is equal to the escalated cost of the original system.

50,000 hours for the closed-cycle system. Components which operate in high-temperature environments are recognized as having severe corrosion and sulphidation characteristics and restricted maximum metal temperature. Accessibility, maintainability and at-sea repair of critical components were also given consideration.

In order that closed-cycle engine systems achieve the specific weight and fuel consumption levels presented in Section III, attention to future technology and cost factors will be required. In turn, heat exchangers, control systems, cooling techniques, gearboxes, shafts, and thrustors will all be affected.

Heat exchangers utilizing aircraft technology will be required to attain specific weights lower than is normal for naval heat exchangers. Internal tube sizes for shell-and-tube types may be as small as 0.25 inch in diameter. This may require new production welding, brazing, or forming methods to achieve cost levels comparable to those of current heat exchangers which utilize much larger tube sizes. Precoolers and intercoolers could benefit from the use of finned-tube concepts to reach still lower weights if this more complex hardware is found to be cost effective.

It is apparent that a combination of bypass and inventory or temperature control methods will be necessary to utilize the optimum efficiency and allow the rapid response required of closed-cycle engines in ship applications. Bypass control dictates that additional valves and piping are required, while inventory control adds the complexity of high-pressure storage tanks and compressors. Combinations of these control modes may allow a compromise between efficiency, response rates, and cost.

It has been assumed that fabrication of closed-cycle turbomachinery can be achieved with the same manufacturing effectiveness as associated with open-cycle systems and that no new procedures or equipment will be required. This seems reasonable provided the flow dynamics of helium stator and blade air foils do not dictate unusual shapes. Also recognized is the need for leakproof containment of the high-pressure helium, and thus may require modifying the flanging, bearing, and seal design concepts.

With respect to open-cycle engines, it is anticipated that the only area which may require further fabrication technology development is the hot section. Cooling of stationary and rotating metal parts to temperatures below 1600 F while utilizing a 2600 F working fluid will require cooling techniques at or slightly beyond the limit of current technology. Maintaining the cost of these components at current levels will require greater production efficiency and/or new fabrication methods and coating procedures.

Gearboxes capable of transmitting the required power at high loading will require a continued development of lower cost procedures primarily in the area of nitriding and surface hardening of gear teeth. Some new equipment will also be

R77-952566-5

required to machine or grind gears which are slightly larger than any which have been made to date. Improved machining for tooth accuracy will be required as well. In addition, development must continue on epicyclic gearboxes to achieve reasonably priced methods of providing equalized gear load sharing. In closed-cycle applications, the development of a relatively little used arrangement, the single-input, dual-output gearbox would be required to provide minimum specific weight in some situations up to power levels of 150,000 shp.

Cost Estimating Methodologies

Normally, detailed system capital cost estimates are based at the very least on a preliminary system conceptual design, and the estimating accuracy depends on the completeness and quality of information, the time available, and the level of effort allowed to prepare the estimate. However, as stated in the original proposal, P75-335-1 dated October, 1975, the purpose of the engineering cost analysis which was undertaken for this preliminary study was to sort through the economic characteristics of the candidate propulsion systems in an effort to identify those, which in combination with the required technical performance capability, have the greatest potential of meeting naval ship needs. Therefore, UTRC has taken a most expeditious, and yet reasonably reliable, approach to carry out this task.

Power Conversion Systems

The procedures used to estimate and to evaluate the cost of open- and closed-cycle gas turbines for future lightweight ship propulsion systems are different due to the fact that each type is in a different stage of technical development. The Conference Method as well as the Comparison Method (Ref. IV-1) were employed to estimate the open-cycle gas turbine (OCGT) costs for various unit capacities and for desired shaft speeds, while a component sizing program combined with the Unit Method (Ref. IV-1), was used to estimate costs for the closed-cycle gas turbine (CCGT) engines.

Open-Cycle Gas Turbine

Open-cycle gas turbine engines with ratings up to 40,000 shp are available from many manufacturers. Since these engines are generally designed for aircraft and/or industrial applications, their output shaft speeds are generally not suitable for ship propulsion systems. Therefore, in the course of estimating the OCGT costs, a parametric analysis was performed for various power turbine speeds. The methodology used consisted of the following four steps:

1. Determining the past and current selling prices of production engines in terms of dollar per shaft horsepower from published literature, and escalating these values to 1976 dollar values, if necessary. Nelson Cost Index tables (Ref. IV-2) were used to determine the escalation factor.
2. Establishing the power turbine cost-to-total engine cost relationship.
3. Using the UTRC cost estimating program (see Appendix G) calculate the power turbine costs as a function of output shaft speed.
4. Establishing the relationship of total engine price and power level for the band of output shaft speeds considered.

Closed-Cycle Gas Turbine

The cost of closed-cycle gas turbine (CCGT) power conversion systems was estimated by utilizing existing UTRC proprietary computer programs to compute the cost of major system components which were then summed up to arrive at the total power conversion system manufacturing cost. There are four major components, namely, turbomachinery, heat exchangers, ducting, and support structure, for which cost was estimated separately. The basic logics of these cost estimating programs are shown in Tables IV-2 and IV-3 for turbomachinery and heat exchangers respectively. A more detailed discussion of these computer models is presented in Appendix G.

The cost of the helium turbomachinery of different sizes was estimated first by computing the base cost for each of the major turbomachinery parts which were then adjusted for any unusual design conditions and/or manufacturing requirements identified in the previous sections. The results of computer sizing for turbomachinery components (parts) were directly integrated with the component cost computation procedures. In this procedure, correlations for standard component designs and their cost-scaling among different unit sizes and materials selections, established from a survey of existing turbomachinery parts, were used to predict the cost of a given component design. The turbomachinery manufacturing cost was obtained by summing up all the component costs computed. The heat exchanger cost was estimated by adjusting and escalating the base cost of a standardized heat exchanger which was established by correlating a vast amount of cost data, in combination with experience accumulated over the last decade for heat exchanger costing (Ref. IV-3). The base cost obtained from Ref. IV-3 for a given heat exchanger size (heat transfer surface area) was then modified according to the cost estimating logic shown in Table IV-3 to account for several adjustment factors which depend on specific heat exchanger type and design conditions. The results of the heat exchanger sizing program were utilized to select these adjustment factors for various regenerator, precooler, and intercooler sizes considered. Sets of tables containing the major cost parameters, such as design point specifications, physical dimensions, weight, structure, materials were prepared for each of the major power conversion system components to provide detailed input to the cost estimating program. Table IV-4 is an example of such input for the 40,000-shp closed-cycle power conversion system.

Reduction Gearbox

Although greater emphasis was placed on analyzing the propulsion engines than other propulsion systems components, the engineering cost for the gearbox was estimated based on the empirical formula derived from a survey of epicyclic and standard marine gearbox (locked train) designs; the relationship of specific cost (\$/shp) to specific weight (lb/shp) when plotted on a log-log scale yielded the following relationship:

$$\text{gearbox cost (\$/shp)} = 15 \text{ Mg (Wg)}^{.32}$$

where Mg is a multiplication factor based on gearbox type (see Table IV-5) and Wg is the gearbox specific weight.

Transmission Shaft

The cost of shafts for naval ships depends on the type of application, the shaft type, either solid or hollow, the ship speed, and the thruster rotational speed. A survey was made of the results of a recent MARAD Study (Ref. IV-4), to establish base costs. From this MARAD study, it was found that the cost of a finished solid shaft for a 26-knot ship design rotating at speeds from 80 to 150 rpm is approximately 2.5 dollars per pound. Similar cost data were also indicated by the ONR. For hollow shafts and other similar applications, an adjustment factor was established based on engineering judgement; those values are presented in Table IV-6.

Thruster

In a manner similar to that used for gearbox and shafting, the costs of thrusters were estimated from existing data. A survey of the MARAD cost estimates (Ref. IV-4) indicated that the thruster cost varies by type, as would be expected. For example, for fixed-pitch, subcavitating thrusters produced from NiAlBr alloy, the averaged cost is about three dollars per pound. For other thruster types, adjustment factors were established based on engineering judgement, and these are listed in Table IV-7.

Bed Plate and Uptake

Conventional carbon steel I-beam and plate steel are basically the candidate materials for bed plate and uptake, and no major technological innovations are necessary for their use. Based on UTRC cost estimation experience and on the Ref. IV-4 MARAD report data, it was estimated that the unit cost for the finished bed plate and combustion gas uptake would be 1.0 and 2.5 dollars per pound, respectively. No correction factor is necessary since component weight varies directly as area.

Miscellaneous

Components which have not been studied or cannot be identified, such as fuel and oil conditioners, pumping systems, control equipment and subsystems, are grouped together in this miscellaneous category. An averaged estimate of ten dollars per pound was assumed for closed-cycle gas turbine systems, whereas 12 dollars per pound was assumed for open-cycle gas turbine since the open-cycle gas turbine likely will require more elaborate fuel treatment.

Fuel Costs

Fuel costs are based on the individual duty cycle of each selected ship type, the power conversion system performance, heater efficiency, the ship duty range, and the Diesel Fuel Marine (DFM) fuel type specified. The heating value of DFM specified by ONR was 5.83×10^6 Btu per barrel, and the cost expressed in 1976 dollars was \$16.10 per barrel. Although the heat source to be integrated with the lightweight propulsion systems will be investigated more thoroughly in the Part II follow-on study, the fuel cost can be estimated from the following relationship:

$$\text{Fuel Cost} = \frac{\left[\text{Conversion Factor} - \frac{\text{Btu}}{\text{shp-hr}} \right] \left[\text{Time} - \text{hr} \right] \left[\text{Fuel Price} - \frac{\$}{\text{bbl}} \right]}{\left[\text{Heater Efr.} \right] \left[\text{Power Conv. Eff.} \right] \left[\text{Fuel Heating Value} - \frac{\text{Btu}}{\text{bbl}} \right]} \quad (\text{IV-1})$$

which, for the noted heating value, fuel cost, and a heater efficiency of 90 percent reduces to:

$$\text{Fuel Cost} = 7807 \times 10^{-6} \sum_i \frac{t_i}{\eta_i}$$

where t_i represents the number of hours spent at a particular speed as directed by the time-speed relationship, and η_i is the power conversion system part-load efficiency corresponding to that same operating condition.

Power Conversion System Cost Characteristics

The cost of open- and closed-cycle gas turbine power conversion systems was estimated based on use of the methodology and computer programs discussed in the preceding subsection. All estimates are in 1976 dollars, and no development costs or effects of market size and/or duration were included. The costs of closed-cycle gas turbines presented herein are preliminary estimates based on the results of a parametric system design analysis. It must be appreciated that a detailed cost cannot be estimated without at least a preliminary venture analysis directed toward a particular conceptual design of the desired engine.

Open-Cycle Gas Turbine

A survey of the open-cycle gas turbine selling prices, including those for aircraft derivative and for industrial-derivative engines, were extracted from literature published in 1975 and in 1976, and these results are presented in Fig. IV-1. It can be seen that the selling prices for both types of engines are intermingled, and as a result, a single trend line appears applicable to both types of engines. The prices for power ratings above 50,000 shp are essentially for the industrial-derivative engines, most of which have been developed only in recent years. The trend line in Fig. IV-1 indicates that specific prices decrease sharply for unit ratings up to approximately 40,000 shp but tend to decrease more slowly for engines of higher ratings. The specific prices varied from \$60 to \$85/shp for the range considered (20,000 to 50,000 shp). It can be expected that based on these survey data, if an entirely new aircraft-derivative engine of 60,000 shp capacity were developed through utilization of substantially high technology, its selling price would undoubtedly be no less than \$60/shp. Because gearbox weight constitutes such a large fraction of total system weight and because this gearbox weight is significantly influenced by the speed reduction ratio, the possibility of varying the gas turbine engine output shaft speed was studied. The performance results of this analysis are discussed in Section III of this report. The effect of power turbine design shaft speed on the baseline OCGT selling price was estimated for shaft speed variation of 600 rpm above and below the reference speed, and the result is shown in Fig. IV-2. By comparing the results of Fig. IV-2 with those in Fig. III-14, it can be seen that for a given reduction in shaft speed, there is much more of a severe effect on the manufacturing cost than there is on specific weight. However, the possible cost savings attributable to the (limited) variances from the reference turbine shaft speed are estimated to be small in comparison to the total propulsion system cost.

Closed-Cycle Gas Turbine

The UTRC cost estimating program was extensively used to analyze the CCGT power conversion systems. Three different turbomachinery configurations and eight unit capacity levels for each configuration were studied, and the estimated capital cost details for each basic power conversion system are tabulated in Table IV-8. The costs of the turbomachines and the heat exchangers are presented in Figs. IV-3 and

IV-4 respectively, and the specific costs of the packaged CCGT power conversion systems using the three candidate turbomachinery configurations are presented in Fig. IV-5. It can be seen that the CCGT turbomachinery Configuration II (i.e., single power turbine) would cost about \$147 per shaft horsepower for a 40,000 shp unit and gradually decreases to about \$71 per shp for the 200,000 shp unit. Although the power conversion systems employing turbomachinery Configuration I (i.e., direct drive) have shown certain advantages in terms of their weight and cost, their application is limited to high-performance ships or high-speed destroyers due to their intrinsically higher output shaft speeds.

The effect of power turbine speed on the turbomachinery cost was also investigated for the CCGT systems, and the results are shown in Fig. IV-6. It was noted in Section III that there appeared to be no severe material stress problem in the power turbine design at shaft speeds 1000 rpm above and below the reference speeds indicated in Table III-3 for the baseline engines. However, the specific cost of turbomachinery would be 20 percent higher if the power turbine is designed at a point 1000 rpm lower than the selected reference speed. Alternatively, the turbomachinery cost would be approximately 10 percent lower when the power turbine is designed at 1000 rpm higher than that of the reference design. It should be mentioned that the reference shaft speeds were selected based on turbomachinery design considerations to yield minimum specific weight for the overall propulsion systems.

Propulsion System Capital and Fuel Costs

The propulsion system equipment and fuel costs were estimated for both open- and closed-cycle gas turbine systems installed on three selected types of naval ships, i.e., the conventional destroyers, high-speed destroyers, and high-performance ships. The capital costs were obtained by summation of the cost data generated or selected for each component, including the power conversion systems, gearbox, shafting, thrusters, bed plate, intake, uptake, and miscellaneous equipment. Fuel costs were calculated from Eq. (IV-1) based on system efficiency, duty cycle, fuel price, and operating time considered. The results are shown in Table IV-9 and Figs. IV-7 through IV-9. Although the heater cost characteristics (for the CCGT only) will be investigated in Part II follow-on study, the cost constraints that will be imposed on the heater design have been identified through a sensitivity analysis.

Table IV-9 presents the breakdown cost of the propulsion system equipment and the cost of fuel for each 100 hours of operation for the three different ship types. Due to the fact that the heater cost has not been investigated, the estimated total cost for CCGT systems is incomplete. However, the effect of the heater cost can be seen in the Figs. IV-7 through IV-9 where allowances of \$100 to \$200/shp have been included for the fossil-fueled, closed-cycle gas turbine systems.

The following assumptions were made relative to the results presented in Figs. IV-7 through IV-9: 1) there is no maintenance cost; 2) there is no fuel

inflation; 3) the OCGT equivalent replacement lifetime (ERL) is 10,000 hours, a value believed to be reasonable based on the present-day OCGT operating experience; 4) the CCGT lifetime is greater than 50,000 hours, a value which may impose some limitations on the design of fossil heater hot section.

Figure IV-7 presents comparisons of the estimated propulsion system equipment-plus-fuel cost by propulsion system type for conventional destroyers as a function of the accumulated operation time up to a maximum of 30,000 hours. If a fossil fueled heater can be purchased for a cost of \$100 per shaft horsepower, there appears a net fuel cost saving after 20,000 hrs operation, even though the initial capital cost of CCGT is much higher than that of OCGT. At an assumed fossil fuel heater cost level of \$170 per shp, the CCGT system appears attractive for total operating times which exceed 20,000 hrs. Alternatively, when the CCGT system is integrated with a nuclear heat source, the estimated propulsion system equipment capital cost and fuel cost becomes a horizontal line for the lifetime considered. The results indicate that if the reactor could be purchased for as low as \$450/shp, there appears no net cost saving in comparison with the fossil-CCGT or OCGT systems. Similar results are shown in Figs. IV-8 and IV-9 for high-speed destroyers and high-performance ships, respectively.

The above analyses have clearly identified the domain of the heater cost at which a CCGT propulsion system would be economically competitive with a OCGT system. Of course, from a design viewpoint, a fossil-fired heater can be designed at lower cost and for shorter lifetime or at higher cost and longer lifetime to satisfy the performance and reliability requirements. The differences in the capital costs associated with these two concepts must be included in the life-cycle operational cost analysis to be undertaken in follow-on studies.

REFERENCES FOR SECTION IV

- IV-1. Ostward, P. F.: Cost Estimating For Engineering and Management; Prentice-Hall, Inc., Englewood Cliffs, New Jersey. 1974.
- IV-2. Oil & Gas Journal, Vol. 74, No. 31. August 2, 1976.
- IV-3. Guthrie, K. M.: Process Plant Estimating Evaluation and Control; Craftsman Book Company of America. 1974.
- IV-4. Marine Gas Turbine Applications Manual, Vol. II. Ship-Heavy-Duty Gas Turbine Propulsion Systems Integration; U.S. Dept. of Commerce Contract O-35510. The General Electric Company. June 1975.

TABLE IV-1

FACTORS HAVING A SIGNIFICANT EFFECT ON COSTS OF PROPULSION
SYSTEMS FOR NAVAL SHIPS

<u>Open-Cycle Gas Turbine</u>	<u>Propulsion System Components</u>
Maximum cycle temperature Hot section cooling complexity and fabrication requirements Adaptability of current engine designs Maintenance requirements Power turbine shaft speed Lightweight waste heat boiler and steam system requirements Corrosion prevention techniques	Gearbox technology advances - tooth loading, surface hardening Unusual or complex gearbox configurations Thrustor power capacity increases Improvements in hi-speed thrustor efficiency High speed shaft requirements
<u>Closed-Cycle Gas Turbine</u>	<u>Heat Exchangers</u>
Lightweight heat exchanger design and fabrication complexity Inventory and bypass control requirements Helium heater design and fabrication complexity and corrosion prevention Bearing/seal isolation requirements Number of power turbines per engine Maximum cycle temperature Airfoil shape fabrication Engine and power turbine shaft speed Reactor requirements	Small (0.25" dia) tube and lightweight shell design fabrication complexity Complexity of finned tube design for precooler and intercooler Sea water corrosion prevention
	<u>General</u>
	System layout and arrangement limitations Handling or safety requirements Accessibility needs Salt water protection requirements Multiple free turbine feasibility Shock loading considerations Material selection Maintenance, reliability, and life requirements

TABLE IV-2

TURBOMACHINERY MANUFACTURING
COST ESTIMATING LOGIC

$$\text{Turbomachinery cost} = \sum_i \left[\$_i \cdot F_{mi} \cdot F_{si} \cdot F_{li} \right] + \$_{ms}$$

$\$ _i$: Cost of major components including compressor blades, vanes, disks & hubs, turbine blades, vanes, disks & hubs, engine casing, shafts, & bearings

$\$ _{ms}$: Miscellaneous including unaccounted subcomponents assembly, test, quality inspection, etc.

F_{mi} : Component material factor

F_{si} : Component size factor

F_{li} : Component labor factor

TABLE IV-3

HEAT EXCHANGER MANUFACTURING COST
ESTIMATING LOGIC

$$\text{Heat exchanger cost} = \$_b \cdot [F_d + F_t + F_s] \cdot F_m \cdot F_f \cdot F_e$$

$\$ _b$ = Base cost for conventional design

Adjustment factors

F_d : Design type

F_t : Tube side pressure

F_s : Shell side pressure

F_m : Shell/tube materials

F_f : Fabrication complexity

F_e : Escalation

TABLE IV-4

CLOSED-CYCLE GAS TURBINE COST ESTIMATING PROGRAM INPUT PARAMETERS

Data are Shown For a 40,000 shp Power Conversion System

Turbomachinery	Low- Pressure Compressor	High- Pressure Compressor	High- Pressure Turbine	Power Turbine
rating - shp	21,032	21,557	42,589	40,000
max. temperature - F	241	243	1,500	1,214
max. pressure - psia	362	600	580	374
no. of stages	12	12	6	6
no. of vanes (F/L stage)	54/70	94/122	68/54	122/94
no. of blades (F/L stage)	53/67	89/113	61/61	113/109
blade aspect ratio (F/L stage)	1.282/1.254	1.224/1.198	1.489/1.512	1.496/1.493
blade length (F/L stage) -in.	2.198/1.702	1.281/0.988	2.314/2.845	1.756/2.296
blade and vanes materials	AISI410	AISI410	IN100	IN100
blade cooling	NO	NO	NO	NO
disk diameter (F/L stage) -in.	19.6/20.6	21.1/21.7	20.6/19.9	38.4/37.8
disk material	IN718	IN718	A-286	A-286
Heat Exchangers	Intercoolers	Precooler	Regenerator	Heater
rating - Mwt	15.6	27.5	65.7	-
type	{ tube/shell floating head }	{ tube/shell floating head }	{ tube/shell floating head }	-
tube/shell temperature - F	157/241	196/349	839/944	-
tube/shell pressure - psia	300/362	200/224	600/230	-
tube O.D. - inch	0.25	0.25	0.25	-
pitch-diameter ratio	1.50	1.50	1.40	-
heat transfer area - ft ²	3,477	4,845	13,432	-
materials (tube/shell)	monel/ AISI347	monel/ AISI347	Hast-X/ AISI347	-
Ducting	Power Turbine to Regenerator	Regenerator to Compressor	Compressor to Regenerator	Regenerator to High Turbine
Temperature -F	1213	100	244	1500
pressure - psia	374	218	600	580
diameter - ft	1.5	1.8	1.3	1.3
length - ft	15	35	78	20
materials	Hast-X	AISI410	AISI410	Hast-X

TABLE IV-5

MULTIPLICATION FACTOR FOR NAVAL SHIP GEARBOX COST ESTIMATION

<u>Gearbox Type</u>	<u>No. Shaft Input</u>	<u>No. Shaft Output</u>	<u>Multiplication Factor, Mg</u>
Offset	1	1	1.0
Offset	2	1	1.2
Offset	1	2	1.5
Epicyclic	1	1	0.9
Bevel	1	1	1.0
Reverse	1	-	1.2

R77-952566-5

TABLE IV-6

MULTIPLICATION FACTOR FOR NAVAL SHIP SHAFTING COST ESTIMATION

<u>Ship Speed, knot</u>	<u>Shaft Speed, rpm</u>	<u>Shaft Type</u>	<u>Multiplication Factor, M_s</u>
26	80 - 150	solid	1.0
		hollow	1.75
35	150 - 400	solid	1.0
		hollow	1.75
50 (supercav.)	500 - 1800	solid	1.25
		hollow	2.50
SES Waterjet	400 - 2000	solid	1.25*
		hollow	2.25*

* Does not require stern tube and tail shaft

R77-952566-5

TABLE IV-7

MULTIPLICATION FACTOR FOR NAVAL SHIP THRUSTOR COST ESTIMATION

<u>Thruster Type</u>	<u>Material</u>	<u>Multiplication Factor, M_t</u>
F.P. - Subcavitating	NiAlBr	1.0
F.P. - Supercavitating	Titanium	2.0
C.R.P. - Subcavitating	NiAlBr	3.0
C.R.P. - Supercavitating	Titanium	4.0
Waterjet		4.0

TABLE IV-8

SPECIFIC CAPITAL COSTS OF CLOSED-CYCLE GAS TURBINE POWER CONVERSION
SYSTEMS FOR BASELINE ENGINES

All Costs Presented in Dollars per Installed Power, \$/shp

Installed Horsepower	40K	60K	80K	100K	120K	150K	160K	200K
I. Turbomachinery (Configuration II)								
1. engine	45.50	32.50	26.50	22.50	20.00	17.50	17.00	15.50
2. support structure	0.61	0.42	0.32	0.27	0.23	0.19	0.19	0.15
II. Heat Exchangers								
1. intercooler	5.50	5.75	4.95	4.72	4.43	4.25	4.23	4.05
2. precooler	7.20	6.04	5.99	5.74	5.31	5.10	5.00	4.90
3. regenerator	43.74	39.19	36.22	35.45	32.11	29.55	27.89	23.84
4. installation (supports, insulation, paint, labor)	21.50	19.10	17.94	16.52	15.90	14.76	14.11	12.46
III. Ducting	1.01	0.90	0.80	0.76	0.70	0.60	0.58	0.50
IV. Miscellaneous (valves, joints, instrumentation, etc.)	22.18	17.44	14.91	13.26	12.13	10.96	10.74	9.80
V. Total	147.25	120.74	107.63	99.22	90.81	82.91	79.74	71.20

TABLE IV-9

ESTIMATED PROPULSION SYSTEM EQUIPMENT CAPITAL COSTS AND FUEL COSTS

Capital Costs Presented in Dollars per Installed Power, \$/shp

Fuel Costs Presented in Dollars per shp for 100 Hours of Operation

Ship Type	Destroyer		H.S. Destroyer		HPS	
	OCGT	CCGT	OCGT	CCGT	OCGT	CCGT
Installed Power - snp	80,000		160,000		200,000	
Displacement - long tons	4250		4000		3000	
Propulsion Systems	OCGT	CCGT	OCGT	CCGT	OCGT	CCGT
Power Conversion system	81.00	118.50	63.50	84.00	63.50	115.00
Gearbox	21.33	15.84	21.57	10.46	20.85	10.46
Shafting	6.90	6.90	1.98	1.98	1.70	1.70
Thrusters	10.8	10.8	3.00	3.00	2.31	2.31
Bed Plate	1.14	1.31	0.73	1.09	0.81	1.27
Intake and Uptake	4.50	*	4.50	*	3.00	*
Heater	NA	*	NA	*	NA	*
Miscellaneous	35.52	25.00	23.16	12.70	20.40	12.80
Total Capital Cost	161.19	178.35 [#]	118.44	113.23 [#]	112.57	143.54 [#]
Fuel Cost ⁺	0.51	0.38	0.68	0.57	1.13	1.02

* To be investigated in Phase II.1 of Part II study

[#] Does not include heater⁺ Based on Diesel Fuel Marine

TYPICAL SELLING PRICE FOR OPEN-CYCLE GAS TURBINES

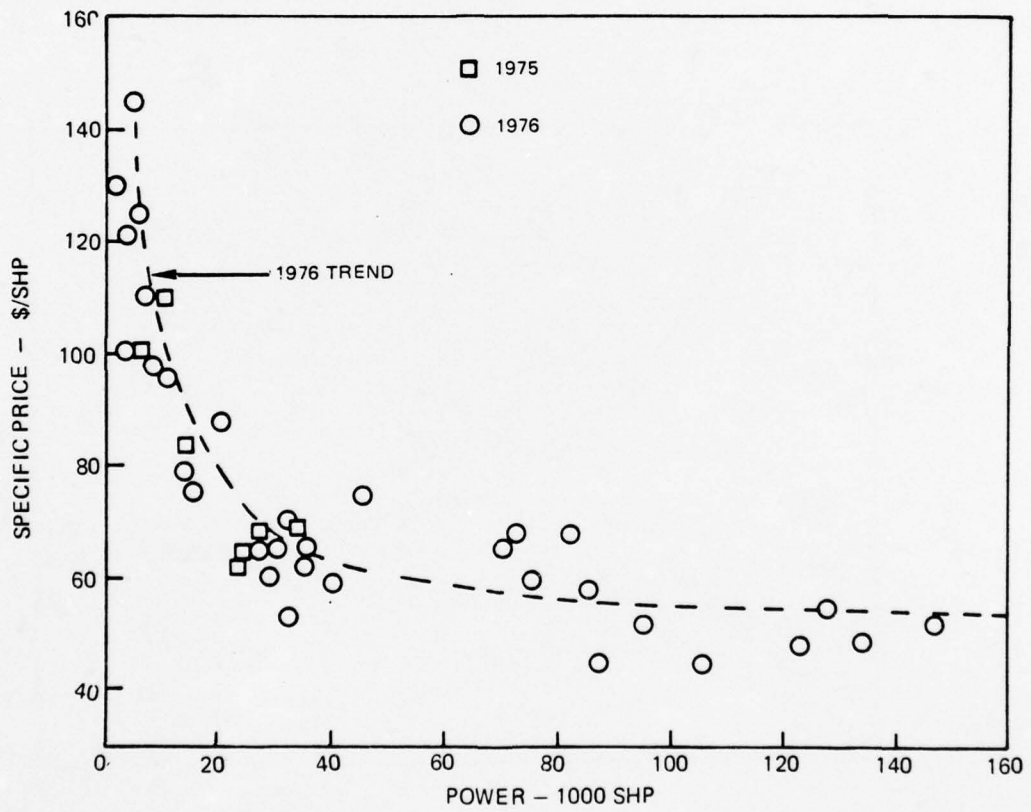

EFFECT OF POWER TURBINE RPM ON ESTIMATED BASELINE OCGT SELLING PRICE

EFFICIENCY = 90%

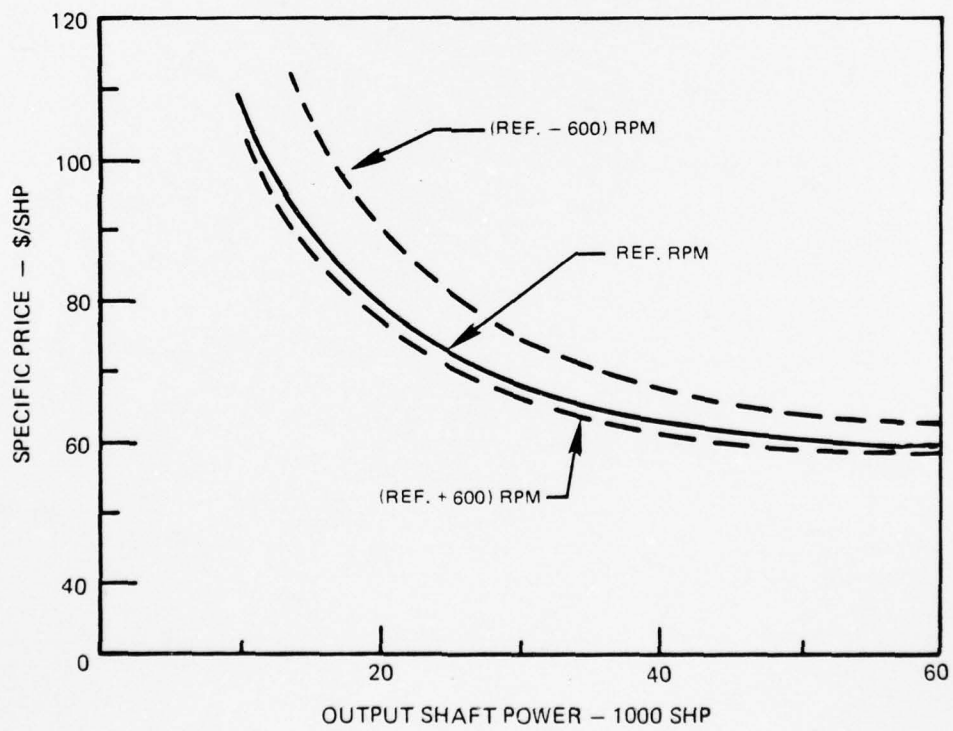

AD-A040 032

UNITED TECHNOLOGIES RESEARCH CENTER EAST HARTFORD CONN F/G 21/5
LIGHTWEIGHT PROPULSION SYSTEMS FOR ADVANCED NAVAL SHIP APPLICAT--ETC(U)
MAY 77 S C KUO

N00014-76-C-0542

UNCLASSIFIED

UTRC/R77-952566-5

NL

3 of 3

AD
A040032



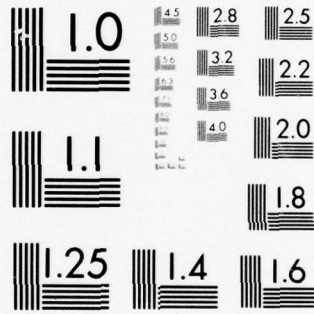

MICROCOPY RESOLUTION TEST CHART
NATIONAL BUREAU OF STANDARDS-1963-A

ESTIMATED BASELINE CCGT TURBOMACHINERY SELLING PRICE

TURBINE INLET TEMPERATURE = 1500F

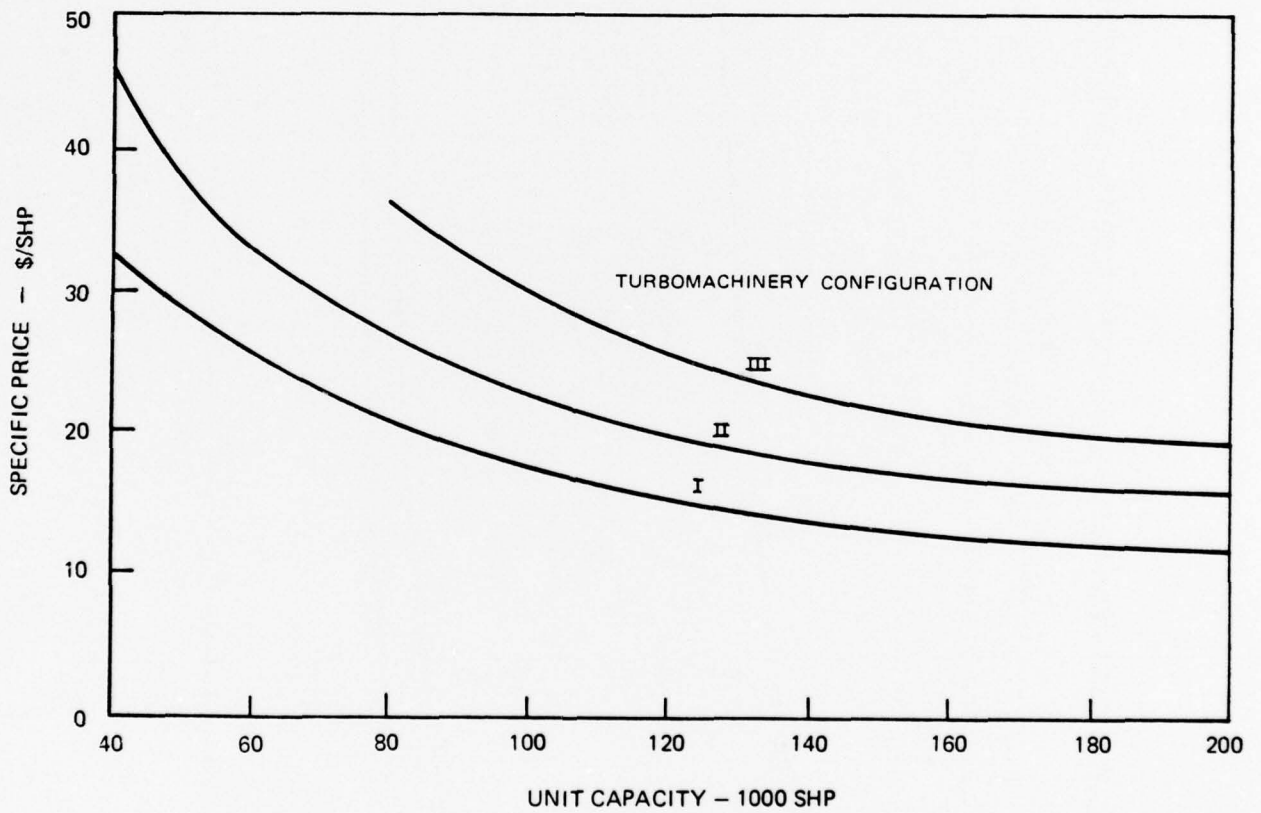

ESTIMATED HEAT EXCHANGER SELLING PRICE FOR BASELINE CCGT SYSTEMS

TURBINE INLET TEMPERATURE=1500F
TUBE SIZE(O.D. INCHES)=0.25

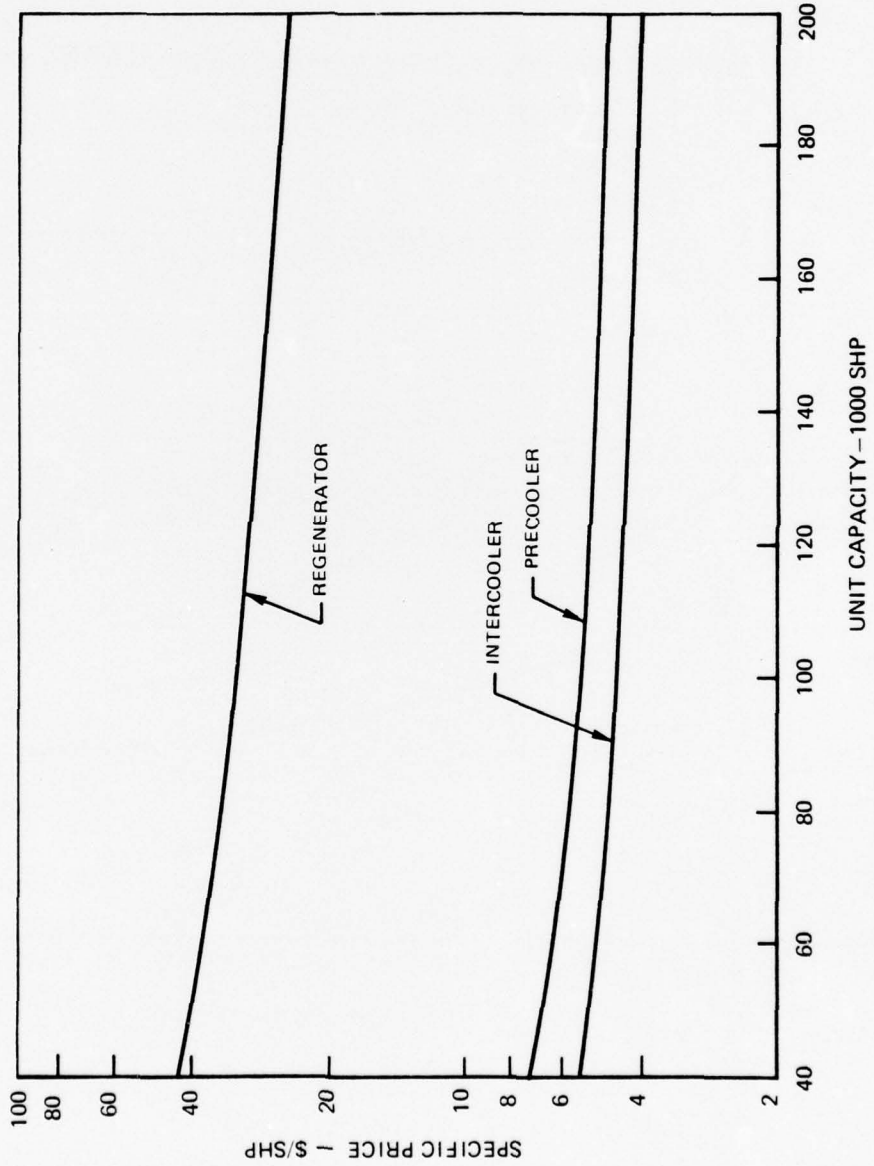

ESTIMATED CCGT POWER CONVERSION SYSTEMS SELLING PRICE

TURBINE INLET TEMPERATURE=1500F

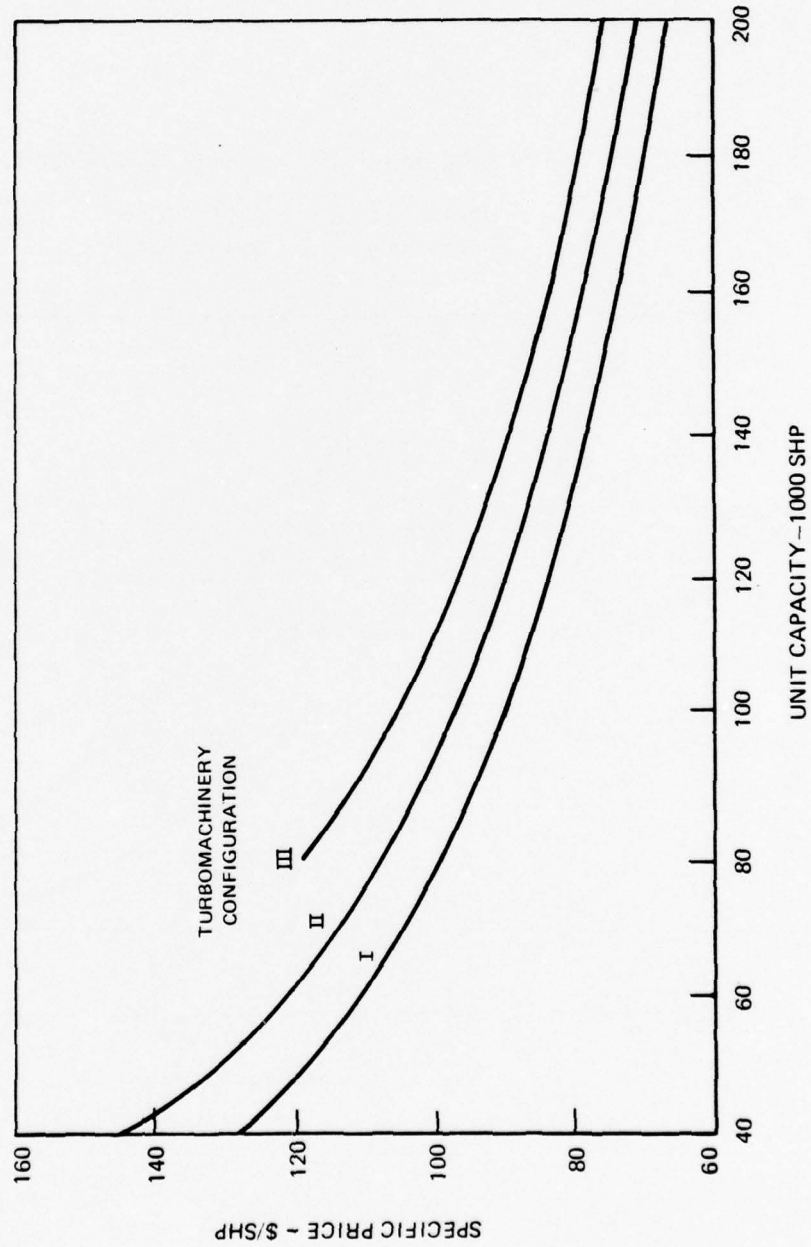

EFFECT OF SHAFT RPM ON CCGT TURBOMACHINERY SPECIFIC PRICE

TURBINE INLET TEMPERATURE=1500 F
TURBOMACHINERY CONFIGURATION II

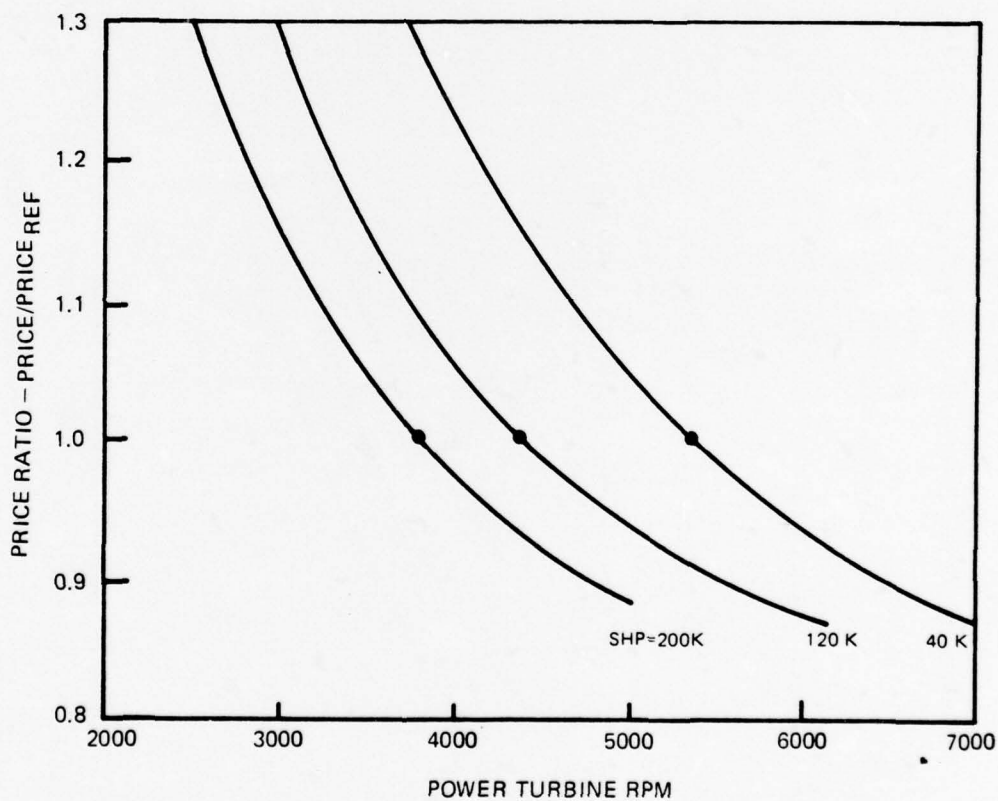

COMPARISON OF PROPULSION SYSTEM EQUIPMENT CAPITAL COST PLUS FUEL COST
FOR CONVENTIONAL DESTROYERS

- NO MAINTENANCE
- NO FUEL PRICE INCREASE
- OCGT LIFETIME=10,000 HOURS
- CCGG LIFETIME=30,000 HOURS

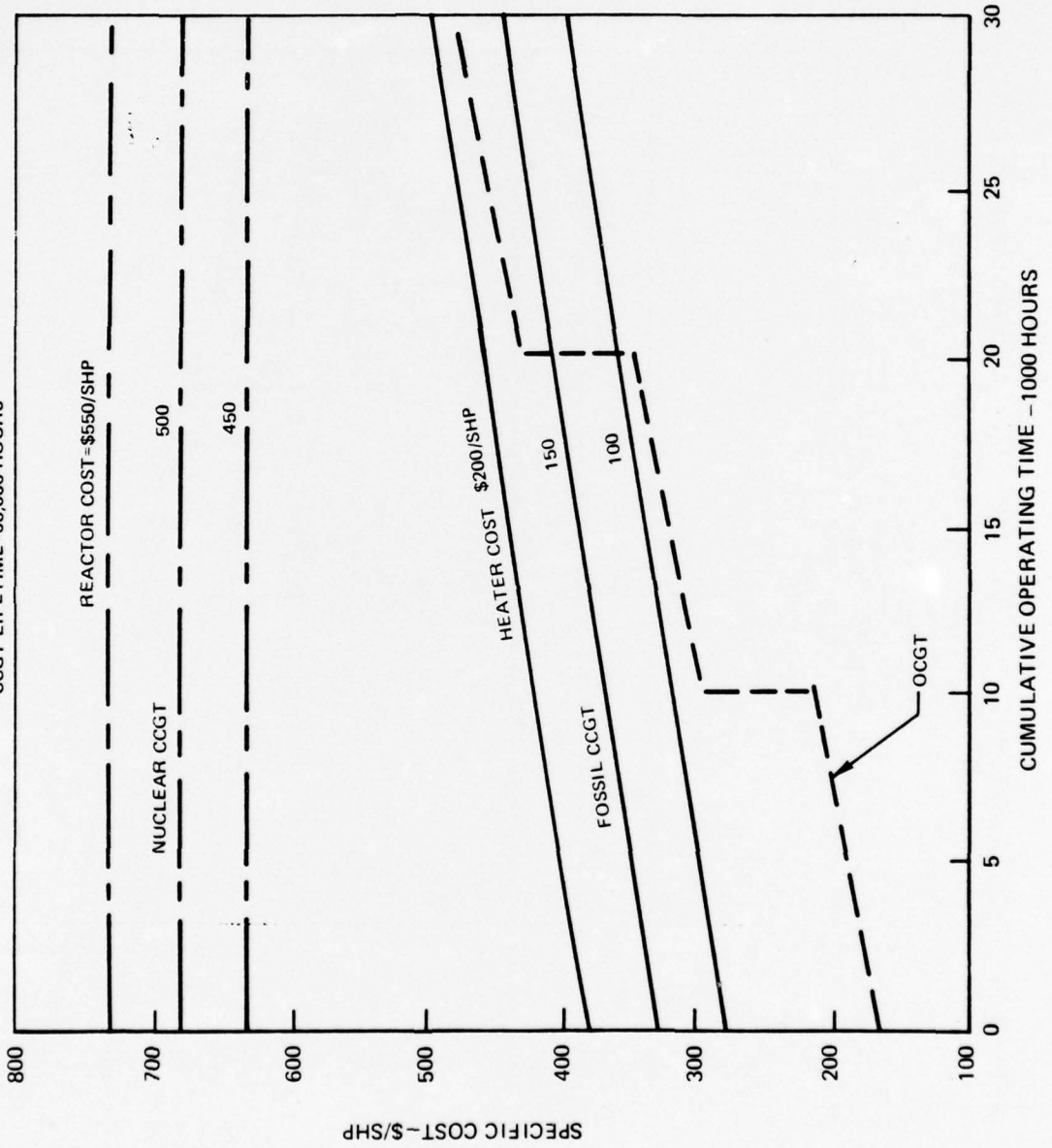

COMPARISON OF PROPULSION SYSTEM EQUIPMENT CAPITAL COST PLUS FUEL COST FOR HIGH - SPEED DESTROYERS

- NO MAINTENANCE
- NO FUEL PRICE INCREASE
- CCGT LIFETIME=10,000 HOURS
- CCGT LIFETIME=30,000 HOURS

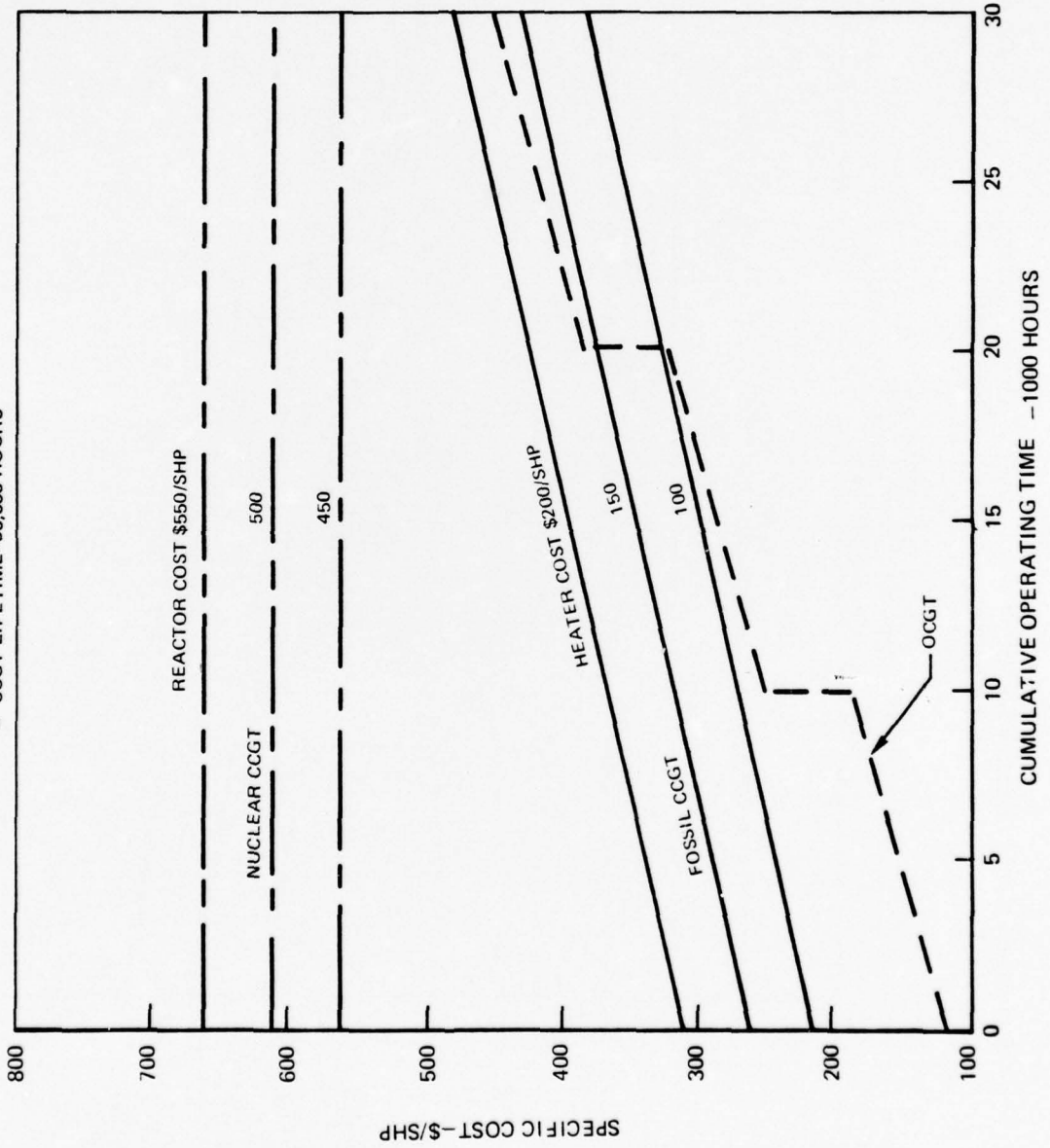

COMPARISON OF PROPULSION SYSTEM EQUIPMENT CAPITAL COST PLUS FUEL COST FOR HIGH PERFORMANCE SHIPS

- NO MAINTENANCE
- NO FUEL PRICE INCREASE
- CCGT LIFETIME = 10,000 HOURS
- CCGT LIFETIME = 30,000 HOURS

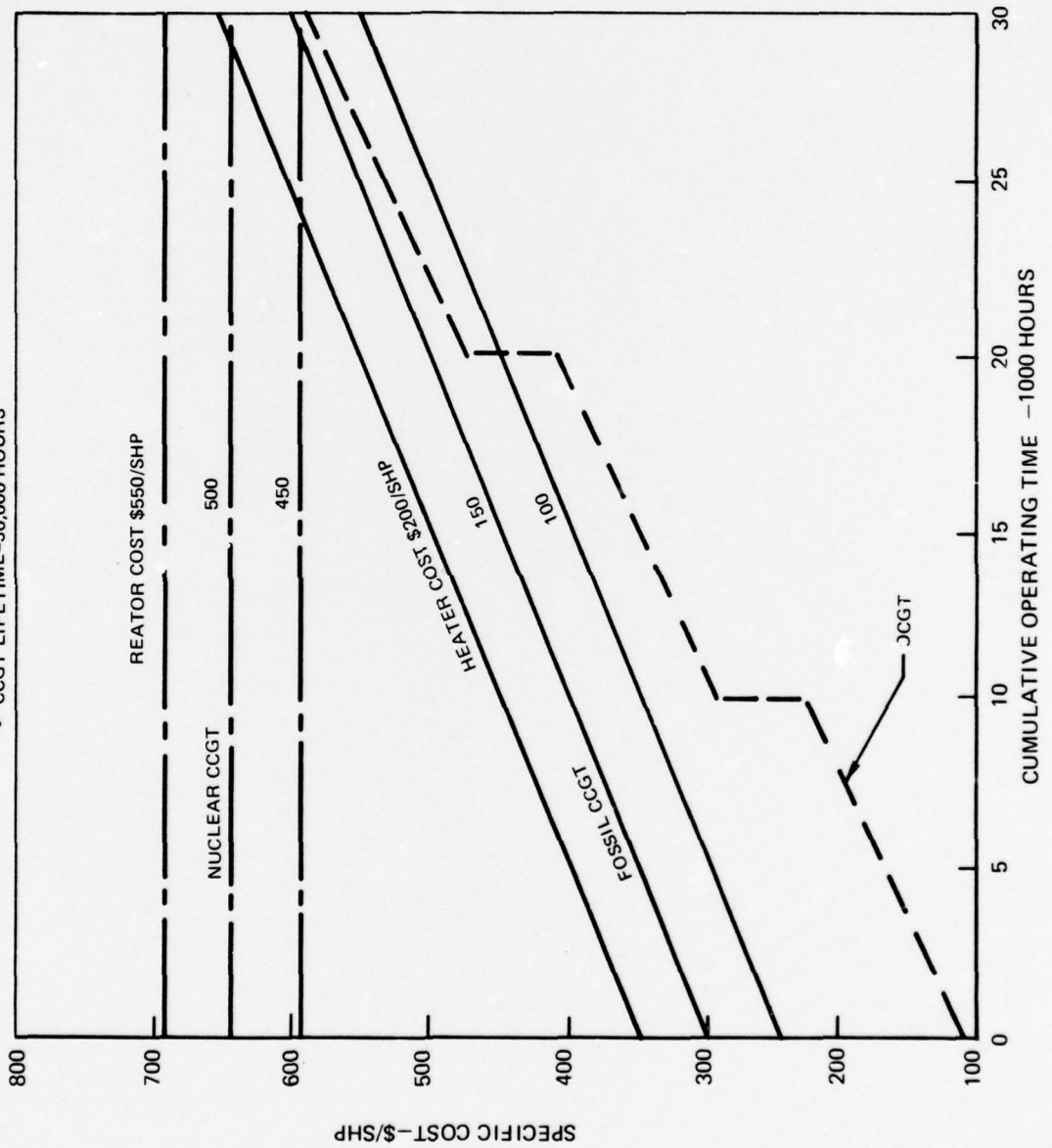

SECTION V

OPERATIONAL CHARACTERISTICS AND LIMITATIONS

When propulsion system operational characteristics and limitations are combined with ship characteristics, an envelope of ship performance is created. Open-cycle gas turbines allow improvements in vehicle response characteristics in comparison with earlier steam plants while requiring greater attention to design details which minimize salt ingestion. Closed-cycle systems might allow more flexibility in ship operation due to the potential for better off-design engine fuel consumption characteristics, and should be able to provide response quicker than the most highly automated steam system. In fact, upon close examination of both open- and closed-cycle gas turbines, it can be realized that more severe limitations on ship operational performance are imposed by the remainder of the propulsion system which ultimately must interact with the environment. Propulsion system operational characteristics and limitations, as well as the concepts, methods and procedures used to estimate them, are discussed in this section.

Fuel Consumption Characteristics

As discussed in previous sections, the quantity of fuel required on board a combat ship can be the most significant factor in determining payload or mission capability. Many concepts have been suggested to minimize this requirement. Particular attention has been focused in the past on the reduction of part-load fuel consumption rates. Operational procedures and limitations are already well established for propulsion system concepts such as steam turbines, COGAG, COGOG, CODAG, and CODOG. Usually these procedures involve switchover from low-speed to high-speed operation to minimize overall fuel consumption. The open- and closed-cycle systems considered in this study also require specific operational procedures and control concepts to minimize fuel consumption. For the OCGT system, a control concept similar to that used on the DD963 and FFG7 is considered to be most suitable while for the CCGT system, a number of concepts are available to provide excellent part-load fuel consumption. These concepts are discussed in the following paragraphs. The thruster characteristics are also identified in these paragraphs as being significant in establishing overall fuel consumption and ship attractiveness.

OCGT Fuel Consumption Characteristics

The typical sfc characteristic for a second generation OCGT shows rapid increase when output power drops below 50 percent of full load as can be seen in Fig. III-4. This problem will continue to require attention for naval combat ship

operations since these ships require very low amounts of power for a large percentage of operating hours (as discussed in Section I). Consequently, the use of a single OCGT per thruster is generally undesirable due to the fuel consumption characteristic shown in Fig. V-1. Such an installation could cause overall fuel consumption rates to exceed existing steam system rates which are typically 0.5 to 0.6 lb/shp-hr at 30 to 40 percent of full power. Utilization of more than one open-cycle engine per shaft (of the same or different output ratings) which allows one or more units to be shut down completely as power is reduced, is a standard solution to this problem. The remaining engine(s) can operate closer to full design power level with better sfc as can be seen in the engine characteristics of Fig. II-3. However, when this approach is used, less than full rated power is available at a reduced shaft speed, due to power turbine and engine characteristics.

These engine characteristics, when combined with typical reductions in propeller speed as vehicle speed is reduced, usually dictate that the switch from two engines to one cannot occur safely until less than approximately 40 percent of maximum thruster power is required. The installation of a smaller engine, either in conjunction with a single-engine, or a dual-engine installation, can further reduce fuel consumption in the region of lowest operational speeds as seen in Fig. V-1. However, these arrangements dictate the use of offset, multiple-reduction gearboxes which are not only costly but also heavy. In addition, higher specific weights are associated with the smaller gas turbines than with large single engines rated at the same total capacity. Each of these considerations affects total propulsion system weight (including fuel) and hence the payload, or endurance, which can affect the feasibility, attractiveness, and mission capability of a given ship type.

CCGT Fuel Consumption Characteristics

In closed-cycle systems, the part-load fuel consumption can be maintained at a level very close to minimum values when inventory control methods are utilized, as seen in Fig. V-2. However, the sizing and location of storage tanks, auxiliary compressors, and engine bleed stations used for inventory control in a closed-cycle gas turbine system must be traded off among the requirements for ship machinery space and weight, part-load efficiency, and propulsion system response characteristics. Tank volume will depend on storage pressure and mass removal desired, while the sizing and power requirements of auxiliary pumping compressors would be similarly affected.

In addition, the actual sfc characteristic associated with inventory control may be complicated by the need to modify the gas turbine component efficiency characteristics to account for the inventory control procedures.

Variations in output shaft speed to accommodate different ship speeds is somewhat different for closed-cycle systems. In principle turbomachinery shaft speed in closed-cycle powerplants can be varied in a manner similar to that used for

open-cycle engines, that is, by reducing heat input. However, in actual practice, large, single-shaft machines using helium as the working fluid require many stages, are relatively long, and are designed for constant-speed operation at a supercritical rotor speed. Machines of this type are normally intended for electric utility operation where speed changes normally are encountered only during start-up, shut-down, or drop-load conditions.

For marine applications, the relative merits or complexities of constant-speed and variable-speed prime movers must be very carefully considered. This consideration also must involve transmission and propeller characteristics as well as the range of shaft speeds to be covered in normal operation. A very large number of variations, trade-offs and compromises is possible. This could include considerations of electrical transmissions (which will not be considered until Part Two of this study) or a reduction in cycle pressure ratio to lessen the required number of stages and make the turbomachinery more adaptable to variable-speed operation. Alternatively, a two-shaft configuration having a free turbine is possible and was given serious consideration during this study. At the very least, the powerplant and its drive train must be provided with some means of disconnecting the thruster and also for driving it throughout a suitable speed range.

Thruster Constraints on Fuel Consumption

In the past, matching of the optimum open-cycle gas turbine operating characteristics with subcavitating propeller characteristics has been accomplished relatively satisfactorily by the careful selection of gearbox reduction ratios (see Fig. II-3, for example). However, when supercavitating propellers and waterjets are to be considered, this engine-to-thruster matching will have to be carefully reviewed in order to provide for acceptable ship operating characteristics. The generation of underwater noise by such a thruster can impose severe limitations on the ability of combat ships to perform their mission effectively. Supercavitating and high-speed subcavitating propellers have been known to generate significant levels of noise yet their characteristically higher shaft speeds can lead to a reduction in the installed propulsion system weight through use of lighter gearboxes, shafting, and propellers, as discussed in Section III. Use of the waterjet might offer the opportunity to reduce noise, but a predicted reduction of as much as 10 percentage points in overall propulsive coefficient when compared with supercavitating propellers could further restrict payload by requiring added fuel in a fossil-fueled system. Nuclear-fueled, closed-cycles could make thruster efficiency less important, but even when lightweight, less-efficient thrusters are used, meaningful payload may not be available for certain ship types until a nuclear heat source plant with a specific weight less than 15 lb/hp can be produced, as discussed in Section III.

The importance of the thruster in establishing operational limitations cannot be overemphasized. Considerable development has been, and is being, performed on supercavitating propellers, waterjets, and CRP propellers. Improvements in their operating characteristics should greatly affect fuel consumption rate, and hence, overall vehicle attractiveness.

Control Characteristics and Limitations

Every propulsion system requires a functional control system to assure desired operational characteristics within its particular inherent limits. The projections made in Sections II and III of this study have established the potential performance capabilities and limitations for both open- and closed-cycle engine systems in terms of steady-state operation. Achieving these performance levels in OCGT systems should not require any significant development or modifications in existing control systems. However for CCGT systems to provide the excellent part-load performance projected, a new and much more complex control of system components is required. In order to assure efficient and reliable operation, both open- and closed-cycle systems will require specific operational practices supplemented with condition monitoring and preventive maintenance programs; none of these procedures is regarded as new to the marine industry. Thrustors, shafts and gearboxes also have unique limitations and control requirements which can affect the operation of the entire system. The characteristics and requirements of control systems to assure desired operation and their effect on vehicle performance are discussed in the following paragraphs. Some of the propulsion system component limitations and their impact are summarized in Table V-1.

OCGT Control System

OCGT control systems have been proven to provide stable engine operation, rapid transient response and even perform "on line" compensation for variations in external conditions. Basically, the controls used for marine gas turbines must perform the same function as those on aircraft gas turbines. In both types, output power is controlled by modulating the compressor-drive turbine inlet temperature by varying fuel flow to the combustor, either manually or automatically, from the engine room or a remote location. Thus, the energy which is input to the free power turbine (or exhaust jet flow in an airplane) is then also reduced and depending on the output power demand, the power turbine output rpm (or engine thrust) will also change. As shown in Fig. II-2 a map of output power, output rpm and sfc can be generated due to this characteristic. The limitation on power output at any output rpm shown in this figure is often one of the first instances where the operator becomes aware of the control system. This limitation protects the engine hot section by limiting fuel flow or turbine inlet temperature or both.

There are many other unseen ways in which the OCGT control system functions to provide acceptable engine operation. Internal engine pressures, temperatures, rotor speeds, fuel flow and even external considerations (such as inlet air temperature and duct geometry) are routinely monitored and used to instigate appropriate fuel flow modulation. Just to maintain stable steady state engine operation requires compensation for many factors such as gradual thermal growth of engine components, inlet temperature variations, fuel characteristic and flow limitations, and rotational speed requirements. This is done in such a way that oscillations in power output,

overspeed, overtemperature or other unstable conditions will not take on dangerous proportions.

Startup, acceleration, and deceleration are much more complex operations and might not be feasible at all without the current control technology. Starting speed, bleed valve positions, airfoil angles, fuel flow, rotor speed and exhaust nozzle size often must all be carefully set in an exact sequence of events to avoid damaging or terminating conditions such as stall, hung start, shutdown, overtemperature or overspeed.

All of these control functions are directed from a black box which usually occupies only a few cubic feet of space, even when hydromechanical methods are used, as has been done for over thirty years in aircraft gas turbines. Currently much development is in process on electronic or combined electronic and hydromechanical control systems for open-cycle gas turbines which promise even smaller, easier to maintain control modules. The type used does not appear to be a critical item for marine applications. Whichever is chosen, the OCGT control system in 1990 can be easily mated to an automated combined ship and engine control system. Together they will provide simple, safe, rapid ship response through the control of output shaft speed, thruster pitch, and warning systems to insure that operations such as connecting the proper fuel supply and disengagement of turning gear are accomplished.

CCGT Control Systems

Closed-cycle control systems will require utilization of much of the existing OCGT technology. However, the need to monitor and control the operation of the working gas (helium) heater and several heat exchangers in addition to the turbomachinery, makes the task more complex. Additional complexities arise from the "inventory control" concept which requires the timely discharge, storage and recharge of the working gas to the system. This concept as well as the alternative "temperature control", "bypass control", and combined control methods are discussed in the following paragraphs.

In summary, to produce closed-cycle control systems which allow rapid power changes as well as stable part-load operation will require a significant effort to be undertaken in dynamic response studies as well as in hardware development and testing programs. The designs of components such as ducting, bypass valves, storage tanks, accessory compressors, heat fuel controls, heat exchanger water flow regulators, and damage prevention monitors will have to be considered carefully in order to provide for effective control operation. The choice of which of several control mode options is best for a specific application will depend, in part, on these options and trade-offs and in part, on specific operational requirements of the power system.

Inventory Control

The power obtainable from a given closed-cycle powerplant at a particular temperature level and operating speed is almost a direct function of the quantity of working fluid which is circulated in a unit of time. This, in turn, is related to the pressure and fluid velocity of the system. In "inventory control" part of the helium gas in the closed-cycle loop is removed to reduce the pressure level and mass flow rate, thereby reducing the delivered power of the turbomachinery. Cycle efficiency is relatively unaffected by these changes of system inventory in the upper half of the power range, but it degrades progressively in the lower half of the range as parasitic losses become an increasingly large fraction of the total power output. (The lower curve of Fig. V-2 indicates a general, but representative, relationship between cycle sfc and power output when inventory control is used, although the characteristics of a specific powerplant will be somewhat different, depending on its design detail.) However, establishing actual component efficiency variations, core engine and power turbine speed restrictions, and stall characteristics will require considerable engine testing operation. The extracted helium must be stored in high-pressure tanks charged by simple, small gas compressors, where it can await recall. At the same time, water flows to the precooler and intercooler, as well as fuel flow to the working gas heater will have to be varied to provide careful control of gas and metal temperatures.

Inventory control is positive, and is potentially quick-acting if suitable pumps and containers are available for handling the working fluid. In particular, rapid power increases are possible if supplementary working fluid, stored at high pressure can be reintroduced rapidly into the power system. Thus inventory control can operate effectively over a broad power range and is most advantageous in its effect on cycle efficiency, but would depend on complex control systems.

Temperature Control

The power which can be obtained at a given inventory level and operating speed will vary directly as cycle temperature. This is a less efficient control mode than is inventory control, since any significant variation from design temperature corresponds to an off-design operating condition which normally results in decreased component efficiencies. Figure V-2 indicates a representative relationship between cycle sfc and output power for conditions where cycle temperature is varied at constant levels of inventory and machinery speed. Temperature control is useful over a relatively large power range, although it is not desirable for frequent or rapid changes in power. Typically, for a powerplant designed to operate at 1500 F, the minimum temperature at which the cycle would be self-sustaining is on the order of 900 F. In normal operation, the rate of change of nuclear reactor power should not exceed 3 percent per minute, which implies a span of 33 minutes from 100 percent power to 1 percent power. This corresponds to a temperature change of about 600 F or a rate of nearly 20 F per minute. Changes in operating temperature may be desirable when a significant change in power level is to be made which will be sustained

for an extended period of time, although this approach is not suitable for rapid power changes when the heat source is nuclear since it can introduce undesirable stress and fatigue damage if the changes are made rapidly and frequently.

Bypass Control

The most effective way to make positive and rapid power changes in a closed-cycle powerplant is to vent part of the compressor flow from the compressor discharge to a point in the fluid circuit just downstream of the turbine. This reduces the power which the turbine can produce, while maintaining the power which the compressor absorbs, thus directly affecting the net output of the powerplant. It is necessary to adjust the powerplant heat input to maintain constant cycle temperature when a bypass control is used, but the change is minimal and the waste heat can be rejected in the precooler.

The relationship between cycle efficiency and power output when bypass control is used is illustrated by the higher curve of Fig. V-2. This control mode is effective over the full power range and can act as rapidly as a valve can be made to open or close. Its principal disadvantages are the large change in cycle efficiency and the need for extra precooler capacity. Furthermore, it is not suitable for extended operations at low power levels in installations where fuel consumption is an important consideration.

Combined Control Modes

Although no single control mode described above can satisfy all the conditions which a marine, closed-cycle powerplant might be expected to encounter, each of them has merit and should be considered. Fortunately, they can be used individually and in combination to achieve all the control actions required for practical operation.

Since inventory control is most suitable for maintaining cycle efficiency over a broad power range, some provision for pumping the working fluid to a high pressure and storing it at that pressure is desirable. However, it may not be necessary to provide high-pressure storage for all of the working fluid or to provide the pumping capacity required for active power control purposes. Bypass and temperature controls, in combination with inventory control, could provide reasonable cycle efficiencies over a range of low power levels. Rapid increases in power from a low power level to one at a higher level could be accomplished by readmitting the working fluid into the system from the storage tanks and by closing the bypass valve. Rapid power reductions could be achieved by means of using the bypass valve over the whole power spectrum, although this would be accomplished at some loss in cycle efficiency. However, efficiency could be restored during a subsequently moderate period of time by pumping fluid inventory back to the storage tanks and by utilizing temperature control at a correspondingly moderate rate.

Multiple Powerplants

It is common practice in both marine and flight applications to use multiple powerplants in the interests of vehicle safety and reliability. In effect, this introduces an additional control option, since it may be quite feasible to change the level of power by selecting the number of powerplants to be operated at any given time.

Past UTC conceptual design studies of closed-cycle gas turbines for integration with high-temperature gas-cooled reactors or advanced fusion reactors indicate that it is entirely feasible to operate several sets of turbomachinery from one reactor and that one or more turbomachines could be shut down while others remain in operation. It should be equally feasible, and perhaps simpler in some respects, to operate two or more closed-cycle powerplants in parallel. The operating efficiency of the resulting power system and its ability to respond rapidly to desired changes throughout its full power range then would depend on the characteristics of the individual powerplants and on the extent to which inactive powerplants were maintained in a standby mode.

CCGT Control Considerations and Tradeoffs

Of the three control modes, inventory control is the most awkward physically because of the need for high pressure storage vessels and pumps. This implies that the extent of its use must be considered very carefully, keeping in mind the objective of minimizing tankage volume and weight and pumping requirements. If two powerplants are to be used in parallel, for example, it might be desirable to operate one at a full inventory level while providing storage for a portion of the inventory in the other. This would permit efficient operation to levels as low as 25 percent of total installed power, while allowing the two powerplants to be interconnected for greater flexibility in operations.

Temperature control is virtually implicit in a closed-cycle powerplant, since there are well defined temperature limits which the heat source and other elements should not exceed if system integrity is to be preserved. There also may be distinct limits on the rate at which temperature can change without inducing damage. The choice then becomes one of deciding how to use temperature control and how to integrate it with other control modes for optimal operation. In general, temperature control is not useful for rapid power changes but is useful in optimizing efficiency after power has been changed with a bypass control.

A bypass control will almost certainly be needed as protection against turbomachinery overspeed in cases of drive shaft failure or momentarily powerplant unloading in the course of reversing or vessel broaching in heavy seas. Since bypass control can act quickly and positively over the full power range, it is a logical choice for the rapid power changes which may be required for maneuvering. However,

since low efficiencies at low power levels accompany the use of bypass control, it must be supplemented by inventory and/or temperature control for sustained operation at low power levels.

Control systems finally selected for OCGT and CCGT systems should allow for engine room operation from at least two remote control stations such as from the bridge and from a ship control center. Provisions which would allow for the operation of the propulsion plant directly from the engine room, if other systems were interrupted, should also be provided. The operating characteristics of the basic CCGT control modes are summarized in Table V-2.

OCGT Monitoring

In efforts to insure the reliable and long-life operation of open-cycle gas turbines, a rather well-established series of preventive and inspection measures are already in common practice. The effects of sulphidation and corrosion within open-cycle engines are well known and require that the cleanliness and purity of the inlet air and the fuel must be maintained. Rigorous monitoring and inspection procedures are required to ensure this requirement. Many methods to remove large water particles and further demist the engine inlet air have been developed, although these will need continued improvement to minimize the effect of damaging chemicals, such as sodium, which interact with internal engine hardware. In addition, conditioning of fossil fuels for both open-cycle gas turbines and the heaters for some closed-cycle systems will be required to minimize the corrosive effect of harmful impurities such as sodium, sulfur and vanadium present in typical fuels. Fuel conditioning generally consists of washing, filtering, and/or the injection of additives. The levels of sodium and potassium which remain after fuel conditioning are generally less than one part per million (ppm) and as a result, little opportunity exists for the formation of highly corrosive products such as sodium vanadyl vanadate ($\text{Na}_2\text{O} \cdot \text{V}_2\text{O}_5 \cdot 5\text{V}_2\text{O}_5$). Fuel additives containing magnesium and silicon compounds such as $\text{Mg}(\text{OH})_2$ and SiO_2 have been found to further minimize the formation of this and similar corrosive compounds.

Inlet, exhaust, and secondary ducts must also be monitored or conditioned to avoid dangerous blockage, icing, or recirculation, which can occur rapidly with the high airflow rates typical for open-cycle gas turbines. Certain external engine components and internal parts also require periodic washdown or inspection. Frequent compressor washing or more stringent cleaning, can restore degraded engine performance by as much as several percentage points. Regular borescope inspections at 10 to 20 engine locations are also necessary for proper maintenance and acceptable reliability. In the hot section of the engine, particularly at the combustor and first stages of the turbine, these frequent borescope inspections can identify developing problems at a time when small modifications in operation or hardware can still be made which would preclude unscheduled engine shutdown or removal. Monitoring of critical engine parameters such as operating pressures, temperatures and speeds as well as vibration and oil characteristics at several locations can also provide good indications of

impending engine maintenance requirements as well as of the condition of the control system.

For a COGAS installation, a considerable amount of monitoring effort can be expected in order to allow for continued acceptable and reliable functioning of the system. The waste heat boilers, condensers, and heat exchangers will require care similar to that now associated with steam powered ships. Additional protective control systems and/or extra men may also be required to operate this type of system when compared with an open-cycle system.

It should be possible to install and remove all of the open-cycle engines considered in this study (up to 50,000 shp) through inlet or exhaust ducting for the ships considered. This is felt to be a necessity, since during the lifetime of a ship, several removals of open-cycle engines will be required to allow for normal overhaul and replacement procedures. Current open-cycle gas turbines in naval operation have achieved a Mean-Time-Between Removal (MTBR) rates of between 2000 and 5000 hours depending upon application. Even with the longest of these times, several removals would be required over the expected 25-year lifetime of naval ships. Industrial-derivative gas turbines with greater overhaul lives could provide power greater than 50,000 shp, but these engines were not considered for this study since they are often so large and heavy that removal from a ship may be impossible without use of a dry dock, while typical naval practice for onboard repair and component replacement could be extremely difficult and cumbersome, if not impossible.

CCGT System Monitoring

Closed-cycle gas turbines using helium as a working fluid could provide vastly increased output power levels without appreciably altering the engine size or monitoring procedures vis á vis the aircraft-derivative OCGT. The largest closed-cycle turbomachinery unit considered in this study (200,000 shp) may still be small enough and light enough to allow rapid installation or removal through the inlet and/or exhaust ducting required for a fossil-fueled heater. In nuclear-fueled configurations, such removal may not be possible without the use of a drydock because of nuclear safety requirements. In general, the closed-cycle turbomachinery is expected to exhibit better reliability than that of the open-cycle system due to its cleaner internal environment. The use of a benign working fluid such as dry, pure helium will allow many of the maintenance problems faced by the open-cycle system to be avoided. Hot-part (turbine and combustor) corrosion due to salt in the fuel and the air is diminished; foreign object damage is eliminated; operation is not affected by heavy seas or water spray ingestion; and the need for large open ducts passing through several deck levels is not required. Exploitation of the ability of CCGT to use any fossil fuel from coal and Bunker C to light distillate and jet fuel could cause special monitoring procedures to be followed for the gas heater while the maintenance of this heater should be simpler and less costly than maintenance of the complex, expensive, cooled, hot section hardware in an OCGT. The regenerators which

utilize metal temperatures of 800-1000 F and heaters, which will operate at metal temperatures of 1600-1800 F, can be expected to require monitoring similar to that for steam system heat exchangers, although this monitoring would be simplified by the lack of phase changes and possible scale buildup on the working gas side. Pre-coolers and intercoolers using fresh or distilled water for cooling should again be expected to require monitoring and maintenance procedures similar to those required for steam system heat exchangers. Heat exchangers for fresh water-to-salt water heat transfer are required for the closed-cycle systems, and again, their characteristics should be very similar to those established for steam propulsion systems.

Internal and external condition monitoring such as borescoping, pressure and temperature monitoring, vibration tracking, and oil condition monitoring would still have to be performed on CCGT units, and these procedures would still be similar to those for the open-cycle engines. Borescoping, or otherwise opening the helium flow path, would probably not be required as often as on a OCGT due to the absence of most destructive elements in the gas path. The storage, loss, and readmission of helium will be an added requirement of the closed-cycle helium gas turbine system. This process should not present many new problems since it can be likened to storage and purging systems installed on commercial LNG and tanker ships.

The comments presented above also apply to the closed-cycle propulsion system that derives its heat input from a gas-cooled nuclear reactor. Use of a nuclear "heater" eliminates the fireside corrosion problem which exists in the fossil heater while at the same time, it introduces the need for near perfect gas leak control. The degree of leak tightness required will depend on the activity level of any fission particles in the circulating helium. Therefore, it may also be necessary to exercise special precautions when opening the ducts to inspect or replace components or to remove and reinstall the engine. This will depend on the level of contamination (if any) of the turbomachinery loop.

Expectations of increased reliability of closed-cycle turbomachinery seem reasonable when experience with OCGT operated in relatively clean environments is reviewed. Gas turbines used for land-based gas pipeline pumping applications have achieved a MTBR in excess of 35,000 hours with an average value of MTBR near 20,000 hours. Closed-cycle turbomachinery should be expected to achieve MTBR values even greater than those for these open-cycle units. It could be visualized that MTBR values of 30,000 to 50,000 hours might even then be achieved by CCGT turbomachinery.

The proposed follow-on Part II study will involve among others utilizing the characteristics presented in this Section V to establish forecasts for the reliability of the future advanced propulsion systems considered. The proposed Part III will take into consideration the characteristics of Part I when developing a comprehensive economic picture and an overall feasibility assessment for the future of lightweight propulsion system utilizing closed-cycle gas turbines.

Other Component Operational Limitations

There are also some operational barriers associated with other propulsion system components such as gearbox, shafting, and thrusters. A reversing capability must be designed into the gearbox or thruster since the gas turbines considered are nonreversing. It is estimated that the epicyclic gearboxes can provide this ability more simply and at lower weight and cost than can offset gearboxes. However, epicyclic gearboxes cannot be exclusively used when the number of input and output shafts is unequal. Clutches and/or brakes must be engaged and disengaged to provide this capability thereby interposing finite response times and power reduction rates into the system. CRP propellers can provide reverse thrust, but rapid changes of blade pitch, particularly at high ship speeds, are normally avoided due to the high blade or hub stresses so created. Supercavitating propellers and waterjets characteristically suffer more severe efficiency reductions during part-power operation than do subcavitating propellers, furthermore, the maximum efficiency attainable by these thrusters is approximately 15 percent lower than subcavitating design maximums. This can seriously affect operational performance, payload, mission, and refueling requirements.

Shafts, the final major component of the system to be considered, also are subject to severe shock loading which is reflected in substantial design safety factors and high specific weight. Extending the design stress to 12,000 psi and using hollow shafts with an inner-to-outer diameter ratio of at least 0.65 as projected in Phase I, may therefore limit safe operation under some conditions since heavy sea or high speed operation can lead to increased shock loading.

Cost-Effective Operation

The vulnerability of the OCGT propulsion system to corrosion suggests that their operation in heavy seas, where more salt water particulate ingestion is likely, will involve a tradeoff among such factors as durability, the immediate availability of power, and reduced maintenance requirements, all of which affect operating cost and mission performance capabilities. Furthermore, the availability of "clean" distillate or residual fuels will determine the amount of effort and time required to prepare fuel for the gas turbine. Clean fuel availability may be a problem in the future as more dependency is placed on lower quality and/or imported fuels which often contain higher levels of vanadium or sulfur compounds and other damaging chemicals. Protecting the capital investment in OCGT systems may require the Navy to follow some special procedures in the operation of ships in the future.

The fossil-fueled, closed-cycle engine should not be as severely affected by these considerations since the only component significantly affected by salt and fuel type would be the heater. (Even this problem area would be diminished with the use of a nuclear heat source.) When a closed-cycle system is installed onboard a naval vessel, its operation should only be limited by ship-related constraints. Furthermore, as has been discussed, annual fuel use should be reduced significantly

in closed-cycle applications, and this can be of great importance to cost-effective operations in the future. The potential to use a broader variety of fuels, including, possibly those derived from coal, could also be of great cost benefit.

Engine durability and fuel cost savings are the two most significant factors in reducing the life-cycle costs of propulsion systems. The CCGT appears to offer a potential promise toward attaining these goals. Furthermore, ship operation would require consideration of vehicle drag and power requirements to determine the optimum fuel-saving, mission-responsive operation. Nuclear-fueled CCGT systems would have to include the capital expenditures for the reactor and the manner by which it would be traded off against projected fuel cost increases and inconveniences. These factors will be considered in detail during Part III of this overall study program.

Response Characteristics

Current ships can respond much more quickly to operational commands than World-War-II-era naval ships, because of progress in steam power plant technology. However, the response time of OCGT systems to change from "cold iron" to full speed condition is unmatched by any steam-power system. The mission of future high-performance ships is also sensitive to the time required to respond from loiter to full speed as well as maneuvering and reverse power capabilities. Again OCGT systems can respond much quicker than steam systems. Closed cycle systems may encounter some of the same thermal response restrictions as steam systems but are still expected to provide better operation characteristics, particularly if computerized total ship control systems are incorporated. The following paragraphs briefly discuss the dynamic response problems from the propulsion system as well as the ship operation view points.

Propulsion System Response

Response characteristics of aircraft-derivative, open-cycle gas turbines are generally much quicker than required for ship operation. For example, sophisticated control systems have been developed which allow aircraft engines to transit from idle to full power in less than 5 seconds while avoiding or accommodating engine dynamic problems. For a marine OCGT to accelerate from idle to full power in 30 seconds is not unreasonable, although more impressive is the fact that only 90 seconds is typically required to go from "cold iron" to full power as shown in Fig. V-3. Deceleration of the gas turbine is primarily constrained by inertia of rotating parts and reverse power input to the power turbine. Input energy can be reduced quickly by reducing fuel flow to prevent overspeeds, while the provision for braking the propeller shaft may be required to slow the speed of the free power turbine in a rapid manner. Only a few seconds are typically needed for the deceleration time of an open-cycle unit.

The response of the closed-cycle gas turbine to power change commands will depend primarily on the type of control system employed and the type of primary heat source. Studies conducted of response rate for the HTGR gas turbine showed that for a nuclear heat source with slow temperature change rates (0 to 100 percent power in 20 minutes) the ability to make rapid power changes required the heat source to be maintained at full temperature, in addition to the fact that a gas bypass around the core and recuperator had to be employed. Such a system was believed capable of full power changes in less than five seconds. Instantaneous drop loads were also handled with only 10 percent overspeed. The determining factor in these cases was maximum bypass valve slew rate and maximum allowable system pressure change rate. Pressure change rates of 300 psi/sec were estimated with value slew rates of $90^{\circ}/\text{sec}$ (Fig. V-4), incorporated into large (400,000 HP single shaft direct drive) gas turbines. A 70,000 HP free turbine design would also tend to accelerate at a much higher rate in the event of propeller broaching. Actual experience with the FT4 in marine service indicates that the fuel control can handle these events satisfactorily. The

closed-cycle bypass system is expected to be as fast acting as is an open-cycle fuel control, and consequently, it is expected that even small free turbine units should be controllable. Figure V-5 illustrates HTGR response time to total instantaneous load losses.

If the heat source is oil-fired, the same bypass control may be acceptable because the high rates of change of pressure do not occur in the primary heater but rather they occur in the bypass duct. Power plant starts from a cold condition with an oil-fired heater faster than those with the nuclear heat source due to the smaller heater mass in the oil furnace. The actual heater design would have to be examined to determine if any other restrictions exist (e.g., thermal stresses) which might limit start-up time.

The use of lightweight design technology in closed-cycle gas turbine systems will greatly enhance their flexibility as marine power plants. Large industrial gas turbines must be started and brought to full load over a period of from 10 to 30 minutes to avoid thermal distortion or blade rubs, while thinner, lower mass, lightweight components do not encounter problems as severe. Thus, the lightweight closed-cycle system might be brought to power as quickly as the primary heater, recuperator, and ducting will permit. Furthermore, the components of the closed-cycle system which may have the most effect on the rate at which operational power changes can be made are the heat exchangers and the helium heaters. Cold start-up might be the most severe procedure required since thermal growth rates of heat exchangers can limit nondestructive temperature change rates. Nuclear-fueled systems may be affected by additional considerations related to reactor temperature change rates, although these could be beneficial by allowing a high "standby" temperature levels to be maintained.

Computerized control systems for closed-cycle systems similar to those proposed for automated steam plants would have to be developed to allow for rapid transients and simple component efficiency matching. Some of the elements which must be controlled include: starting motors; fuel and air flows to the heater; reactor operating levels; water flows to precoolers and intercoolers; water flows to fresh water/sea water heat exchangers; mass flows to and from inventory control tanks; gas turbine speeds and component geometry; and auxiliary equipment operating levels. Other parameters which would also have to be monitored to provide safe and efficient operations and control feedback include: heater/reactor and heat exchanger metal temperatures; gas temperature; inlet air conditions to heater; fuel flow; and auxiliary equipment operating conditions.

Vehicle Response

The control systems required for OCGT and CCGT systems must be able to provide acceptable response in future ships. However, to allow the ship to attain its full potential response characteristics, the overall ship control system should, in

addition, supervise and match the interrelated capabilities and operating requirements for the remainder of the propulsion system components including: propeller speed and pitch, shaft torque, hydraulic system requirements, and clutching, among others. For example, very rapid power response is required when operating in rough sea states because the propeller (or pump in waterjet drive systems) can unload in as little as 0.1 seconds and remain unloaded for 1.5 seconds during broaching. OCGT controls presently available can meet this situation and prevent dangerous turbine overspeeds on high-performance ships where the most stringent requirements of all vessel types studied are placed on the propulsion system. Thus rapid response as well as high power-to-weight, and small sizes are vital to the successful functioning of these ships. Rapid start-up is also important to these vessels since a long start-up period would negate much of the advantage of high speed on short dash missions. Automated and computerized control systems may be a necessary requirement to provide these vehicle capabilities. Thus, the overall ship system controls necessary to integrate the propulsion system with vessel requirements, characteristics, and constraints can affect the feasibility and effectiveness of a new system.

TABLE V-1

COMPONENT LIMITATIONS AFFECTING SHIP OPERATION

<u>Component</u>	<u>Component Limitation</u>	<u>Ship Operational Limitation</u>
Open Cycle Gas Turbine	<ul style="list-style-type: none"> • minimum sfc • sfc/power relationship • corrosion control • inlet filtration • maintenance 	<ul style="list-style-type: none"> • payload or endurance capability • part power procedures • fuel conditioning • heavy sea operation • availability
Closed Cycle Gas Turbine	<ul style="list-style-type: none"> • control system • actual part load sfc • heat exchanger transients • minimum sfc • maintenance 	<ul style="list-style-type: none"> • rate of power change • power adjusting procedures • cold start-up • payload or endurance capability • availability
Transmission	<ul style="list-style-type: none"> • clutch torque • reversing procedures • shock load design safety factors (weight) 	<ul style="list-style-type: none"> • rate of power change • stopping distance • payload or endurance capability
Shafts	<ul style="list-style-type: none"> • maximum design stress (weight) • number of bulkheads (weight) • inner/outer dia ratio • overload safety factor • alignment and maintenance 	<ul style="list-style-type: none"> • rate of power change • payload or endurance capability • availability
Thruster	<ul style="list-style-type: none"> • CRP rate of pitch change • maximum capacity • power/speed/efficiency relationship • noise generation • supercavitating max efficiency • supercavitating and water jet part power efficiency 	<ul style="list-style-type: none"> • reverse response time • part-load fuel use rate • power change procedure • complexity of operation • part power procedure • payload or endurance capability • mission capability

TABLE V-2

OPERATING CHARACTERISTICS OF BASIC CONTROL MODES

	<u>Inventory (Working Fluid)</u>	<u>Temperature (Turbine Inlet)</u>	<u>Bypass (Compressor Bleed)</u>
Rate	Potentially Fast: Depends on tank volume & pressure & pump capacity	For Nuclear: 3%/Min. Normal 5%/Min. Maximum For fossil: depends on furnace design	100%/Sec
Range	Potentially Large: Depends on tank storage capacity	100%	100%
Efficiency	High	Decreases as a function of the decrease in power	Decreases as a function of the decrease in power
Comments	Requires space for tanks & pumps	Limited by thermal stress in heat source	Requires fast valve actuator and control

TYPICAL OPEN CYCLE GAS TURBINE POWERPLANT OPERATING LINES

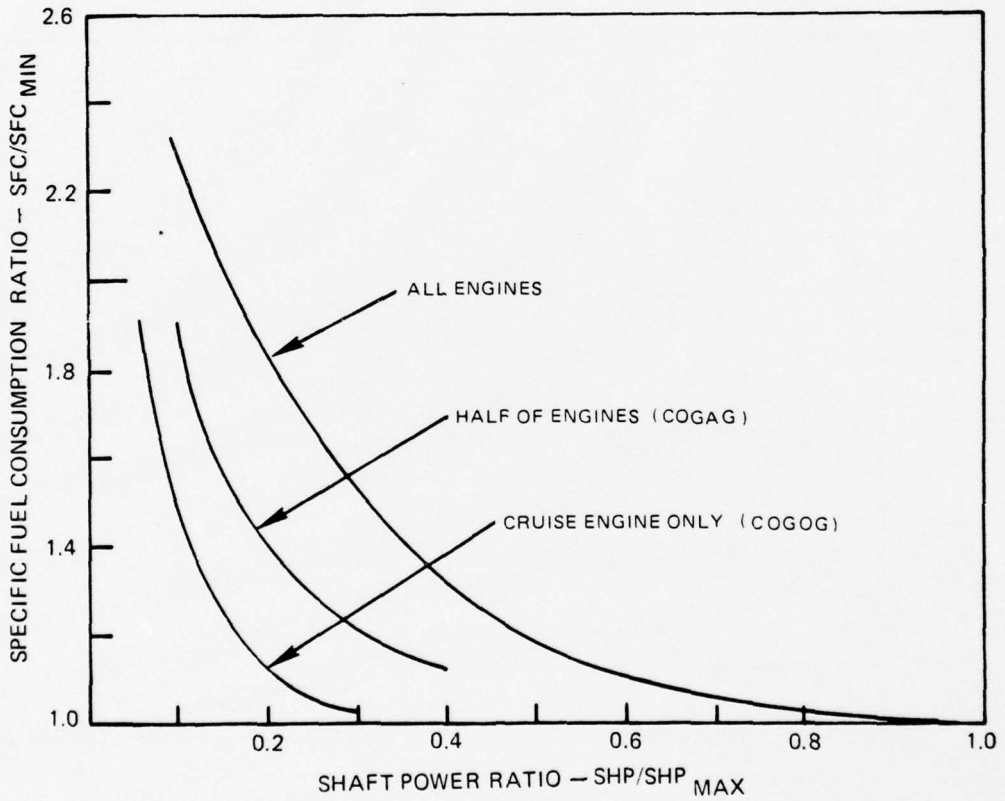

TYPICAL CCGT PART LOAD PERFORMANCE CHARACTERISTICS

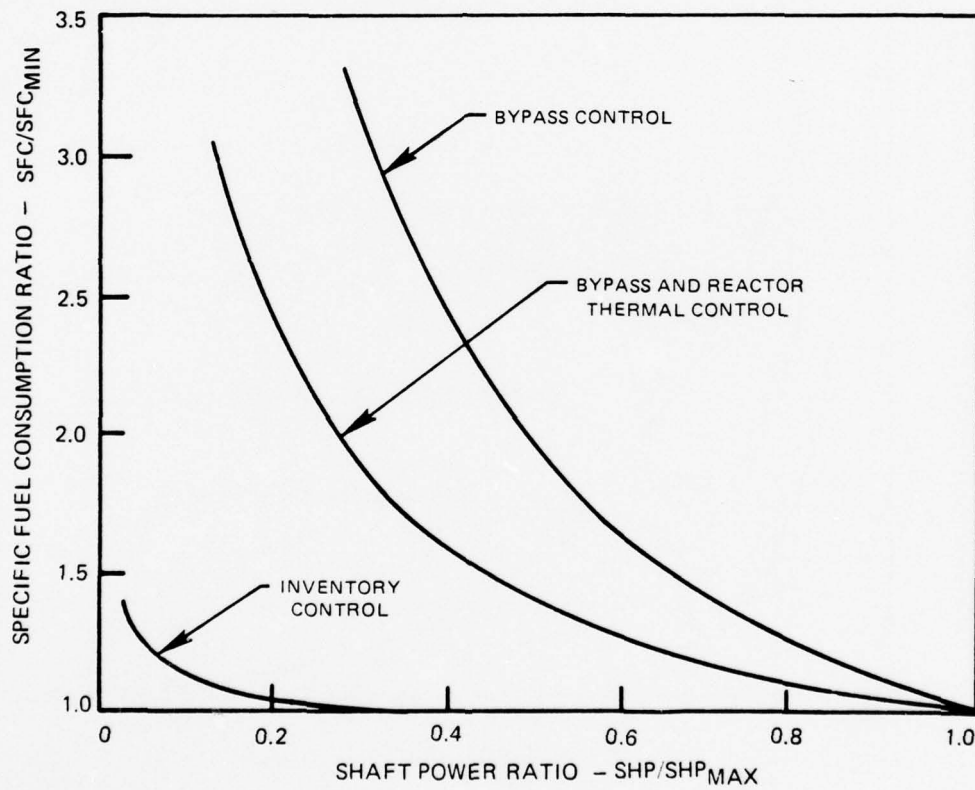

TYPICAL OCGT STARTING TIME

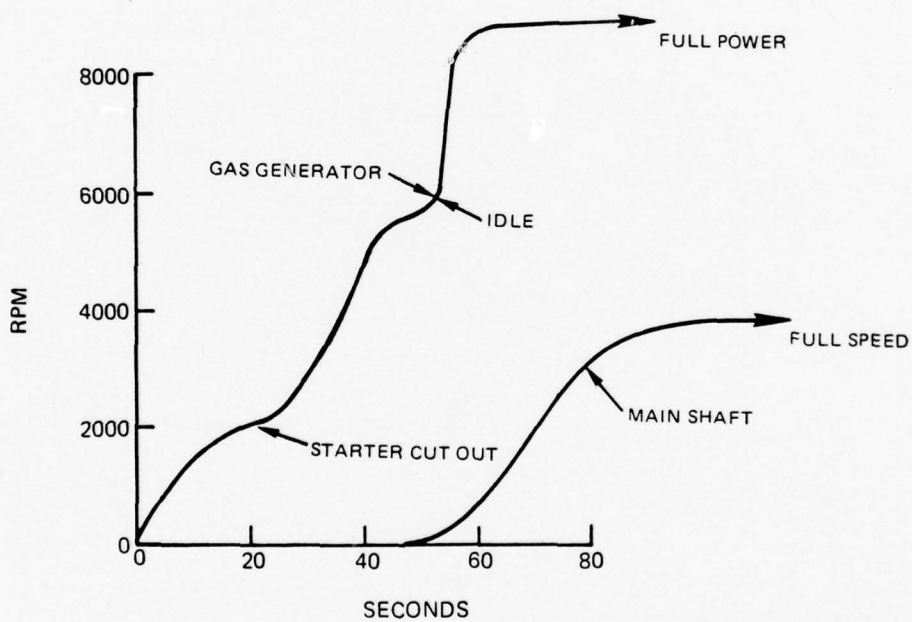

CONTROL ANALYSIS FOR CCGT (HTGR) BYPASS VALVE

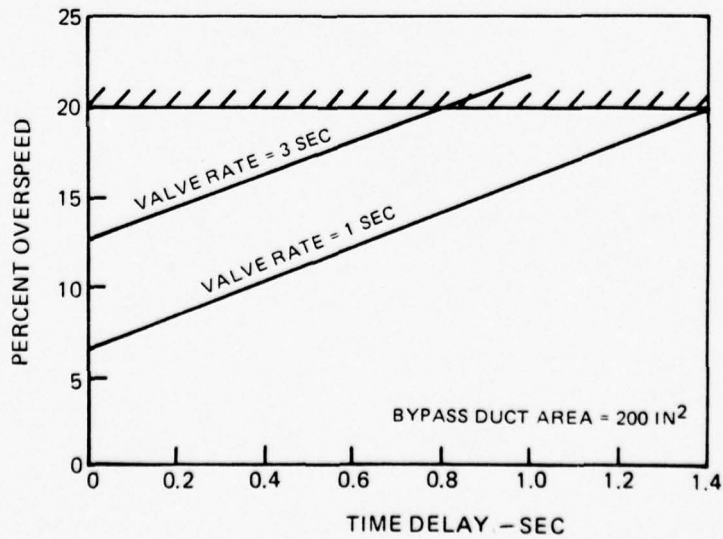
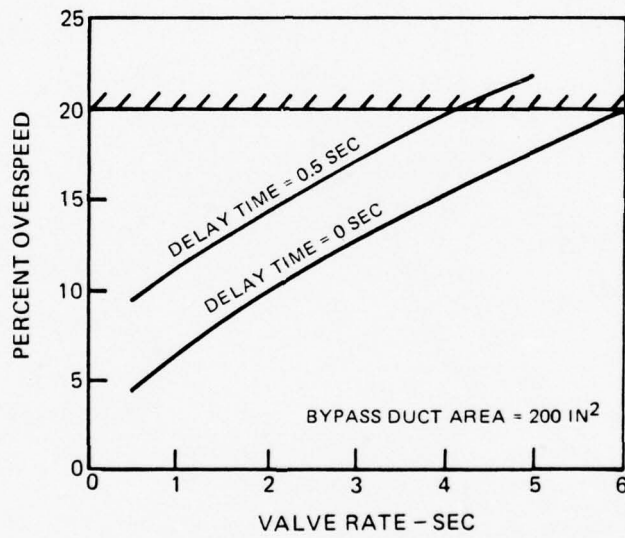
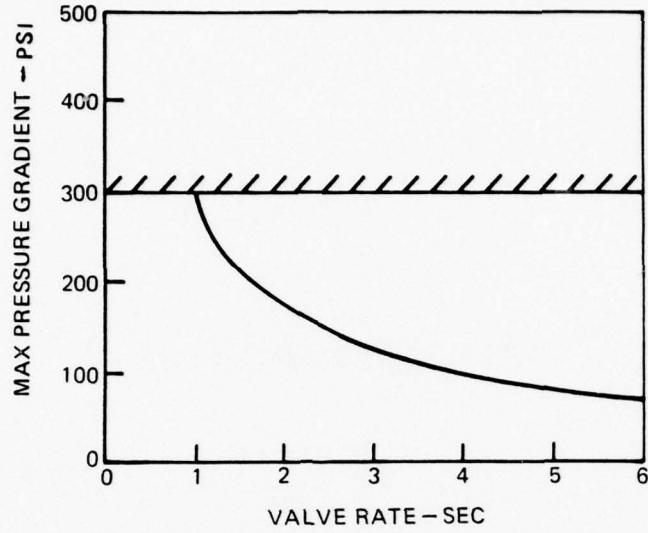

ESTIMATED RESPONSE FOR CCGT (HTGR) DROP LOAD CONDITION

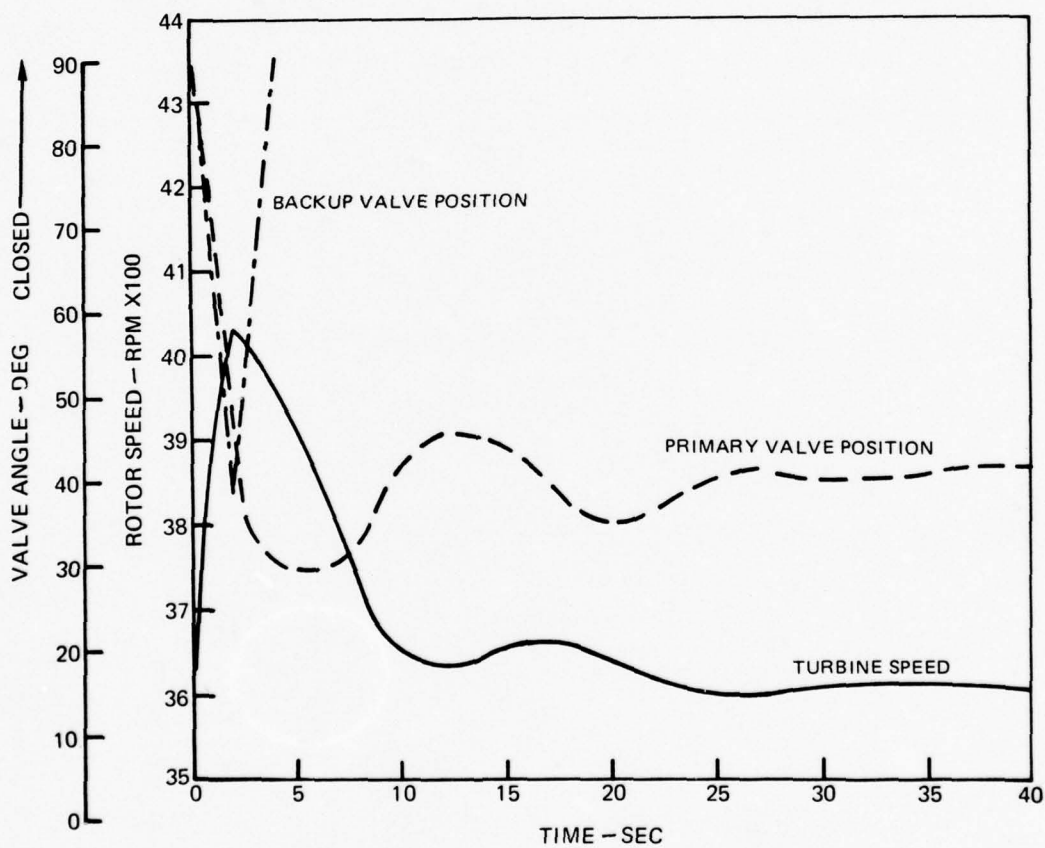

APPENDIX A

SURVEY OF SHIP POWER REQUIREMENTS

The background information, which was used to identify the installed power requirements and to select the ships which would be candidates in 1985 and beyond, for light-weight propulsion systems, is presented in this appendix. Actual installed power is compared with theoretical power requirements for several categories of ships. Lift power requirements for SES vessels and cruise power requirements for selected ship types are also presented.

Definition of Overall Propulsive Efficiency

In general the effective horsepower (EHP) required to overcome hull towing drag is equal to the product of the overall propulsive efficiency (η_{OP}) and the shaft horsepower (or the horsepower delivered to the propeller) as:

$$EHP = \eta_{OP} \text{ SHP} \quad (1)$$

In addition

$$EHP = \eta_H \text{ THP} \quad (2)$$

and

$$\text{THP} = \eta_P \text{ SHP} \quad (3)$$

where the thrust horsepower (THP) input to the water by the propeller is generally greater than the towing resistance or effective horsepower by a hull efficiency factor (η_H). Substituting Eq. (3) into Eq. (2) gives

$$EHP = (\eta_P)(\eta_H) \text{ SHP} \quad (4)$$

Propeller efficiency (η_P) can be divided into two parts: (η_O) and (η_R), where η_O is the open-water efficiency as obtained from series tests, and η_R is a rotative efficiency that expresses the difference in power absorbed by a propeller in open water versus that resulting from operating behind a hull in an actual installation. Finally:

$$\text{SHP} = (\eta_G)(\eta_S) \text{ BHP} \quad (5)$$

where the shaft horsepower delivered to the propeller is less than the brake horsepower (BHP), or installed engine horsepower rating due to gear box efficiency (η_G) and transmission efficiency (η_S) caused by losses in the shaft. Combining Eqs. (4) and (5) and definition of propeller efficiency yields

$$EHP = (\eta_O)(\eta_R)(\eta_H)(\eta_G)(\eta_S) \text{ BHP} \quad (6)$$

which relates a known, or analytically computable magnitude of horsepower required to tow a hull at a given velocity, to the installed horsepower (BHP) required of the propulsion system.

The gearbox efficiency (η_G) is discussed under the gearbox section in the text and is generally on the order of 0.98. Shaft efficiency (η_S) is normally 0.98 for short shafts and 0.97 for long shafts.

Combining Eqs. (1) and (4) yields

$$\eta_{OP} = (\eta_O)(\eta_R)(\eta_H) \quad (7)$$

For this study, the rotative efficiency (η_R) is assumed to be 1.0. The hull efficiency (η_H) is defined as:

$$\eta_H = \frac{1-t}{1-w} \quad (8)$$

where w is a wake fraction that depends on ship speed and the number of propellers installed. Wake fractions for use in the study are based on data from Ref. A-1. Typical values of $1-t$ are given below, where t is a thrust deduction factor which results from the fact that the propeller operates in the hull wake. These data were obtained from Professor Philip Mandel of MIT.

Type of Ship	$(1-w)^*$	$(1-t)^*$	Multiple Shaft η_H	Estimated Single Shaft η_H
Light Destroyer	.98	.95	.969	.862
CVA (2 or 4 Props)	.945	.90	.952	.847
Destroyer Escorts	.94	.89	.947	.843
Aux Cargo Ships	.88	.84	.955	.85
High Performance Ships	1.0	1.0	1.0	.943

* Multiple Screw Ships, subcavitating and supercavitating propellers.

With the above data, and assumptions presented in the previous paragraph, it is possible to derive an overall propulsive efficiency of 0.65 to 0.7 which forms the upper part of the OPC band chosen for conventional displacement ships in Fig. I-2, based on open water propeller efficiencies of 0.68 to 0.74, respectively.

Prediction of Installed Power Requirements

Data in Tables A-I and A-II provide a broad view of naval ship power requirements and propulsion methods for applications with installed power ratings above 20,000 shp (Ref. A-2, A-3, A-4). These installed power requirements, which include data from US vessels as well as those from several foreign governments were then plotted as a function of full-load displacement (see Fig. A-1) with maximum velocity carried as a superscript. When these installed power requirements were compared with theoretical "clean hull" ship towing requirements obtained from Ref. A-5 and A-6, it was seen that the installed power values exceeded the towing requirements by as much as a factor of two. This discrepancy is due to many factors which include: degraded overall propulsive efficiency (OPC) resulting from propeller/hull interactions; excess power necessary for design margins; hull fouling allowances; excessive gearbox losses; and provisions for lift power and nonpropulsion power requirements. For conventional displacement ships, this discrepancy could be rationalized by assuming that OPC values of only 0.5 to 0.7 were attainable and that nonpropulsion requirements constitute an additional 10 percent of total propulsion power. Adjustments based on these assumptions are reasonably close to actual data as indicated by the dashed curves in Fig. A-1.

Since little actual data is available for large high-speed ships, this same analytical approach, when combined with theoretical power requirements, was used to estimate total power requirements for the 50-knot displacement hull destroyer, and high-performance ships, such as hydrofoil and SES. By using OPC values of 0.4 to 0.6 (Ref. A-6) and SES lift power requirements estimated from Ref. A-6 (see Fig. A-2) it can be seen in Fig. A-1 that there is reasonable agreement between the calculated results and the limited data for actual or projected SES and hydrofoils.

Power-speed characteristics from Fig. A-1 were used to generalize the installed power requirements into six displacement speed categories as shown in Fig. A-3. The OPC values on which these generalizations are based range from 0.6 to 0.7 for displacement ships (Ref. A-7) and 0.4 to 0.6 for the high-speed ships. The higher (displacement-ship) OPC range was chosen since the US Navy reportedly operates its vessels closer to these optimum conditions, than do some of the commercial or other ship operators and navies from other countries which were surveyed. In the case of the OPC values for high-speed ships, the bands of power requirements were left wider since considerable uncertainty exists regarding actual attainable values. As a result of these power-speed relationships, the six characteristic bands were assumed to comprise the basic design-point requirements for future ships from which applicable ship types considered in this program could be selected.

APPENDIX B

THRUSTOR PERFORMANCE AND WEIGHT ESTIMATION

This appendix provides a procedure for estimating the performance and weight of three marine thruster types, namely subcavitating propellers, supercavitating propellers, and water jets. The thruster weight estimates were used in the propulsion system weight calculations for each of the various lightweight propulsion systems investigated.

Thruster Performance Estimation

The design of a thruster which will provide optimum vehicle utilization is a complex matter at best. This study was not intended to provide such an optimization, but rather to estimate typical performance characteristics that can be expected for selected thruster types which were judged likely to become available in the 1990's. A simplified analytical approach is presented in the following paragraphs for estimation of thruster efficiency, diameter, and rotational speed as dependent on power input and selected ship velocities. Comparison of these results to existing and proposed designs resulted in the selection of a rotational speed to power relationship and maximum propeller diameter limitations which simplifies the characterization process. Methods to estimate the off-design performance characteristics were also established to allow more realistic fuel consumption estimates for ships operating under various duty cycles.

Design Point Requirements

The maximum velocity required for each ship type was used as a primary factor in selecting the thruster type and design point requirements. Once the thruster type was selected, the design point efficiency was estimated based on a promising design configuration selected. The result was then used in the overall system propulsion studies.

For any propeller design category, the characteristics of diameter, advance velocity, rotational speed, power, and efficiency are interrelated through standard propeller design parameters such as the thrust coefficient (K_T), loading coefficient (C_T), rotative coefficient (B_P), advance ratio (J) and cavitation index (σ) as expressed below:

$$B_P = N(\text{THP})^{0.5} / (V_a)^{2.5} \qquad J = (v_a) / ND$$

$$V_a = V(1-w) \qquad \sigma = 2(p_w - p_g) / \rho(v_a)^2$$

$$C_T = 8T / \pi \rho D^2 v^2 = (1.51)(\text{THP}) / D^2 v^3 \approx 8(K_T) / \pi(J)^2$$

where

- D = propeller diameter, ft
- N = propeller rpm
- T = thrust, lb
- THP = thrust horsepower
- V = ship velocity, knots
- V_a = propeller advance velocity, knots
- p_w = total static pressure on blade surface, psf
- p_g = vapor pressure of water, psf
- v = ship velocity, fps
- v_a = propeller advance velocity, fps
- w = fraction that wake velocity is of ship velocity
- ρ = density of operating fluid, lb/ft³

These parameters were used to generate relationships which, when three propeller characteristics are selected (one of which is velocity) at the design point, would allow all the remaining characteristics to be determined. In this study the use of this procedure centered on the estimation of typical thruster rotational speed and propeller diameter since these design parameters have the most pronounced effect on the propeller weight characteristics.

Subcavitating Propeller Performance

The reference propeller performance data selected for use with subcavitating propellers is based on data presented in Ref. B-1. These data are the results of open water tests in which only the pitch/diameter ratio (P/D) of the design was varied. Figure B-1 illustrates how the efficiency of the selected propeller compares with that of other propellers. The data shown for controllable reversible pitch (CRP) propellers was also taken from Ref. B-1 along an operating line which provided optimum efficiency and diameter at given values of rotative coefficient (B_p). For the fixed pitch (FP) propellers, data was taken from the same reference along a line of constant P/D = 1.1. A summary of these selected propeller characteristics is presented in Fig. B-2 in a form which allows simple determination of diameter and rpm when thrust power, ship speed and efficiency are given.

Rotational speed (N) can be determined from

$$N = B_p \left[V_a (1-w) \right]^{2.5} / (\text{THP})^{0.5}$$

while diameter is calculated from:

$$D = \delta V (1-w) / N$$

where

$$\delta = \frac{101.3}{J}$$

Using these relationships at design speeds of 26 knots and 35 knots and thrust power of 20,000 to 100,000 shp produces the characteristic relationships shown in Figs. B-3 and B-4, respectively. These figures were then used to calculate diameter and rpm when thrust power is known at the velocity chosen. Open water efficiency levels were consistent with the overall propulsive coefficients identified in Appendix A (maximum of 0.7).

Supercavitating Propeller Performance

Reference B-2 was used to provide a propeller performance data map as the basis for developing reference supercavitating propeller performance data. These data are for a fully-submerged, fully cavitating propeller which incorporates 3 or 4 blades. The selected supercavitating propeller design parameters, taken from a line of maximum efficiency at a given thrust coefficient (C_T) are given in Fig. B-5. P/D is fixed at 1.0 for FP propellers and is allowed to float for CRP propellers. The diameter and rpm of supercavitating propellers can be determined from Fig. B-5 at a given efficiency, speed, and power from the following equations:

$$D = 1400 (\text{THP}) / v^3 C_T$$

$$N = \frac{v(1-w)}{JD}$$

The results of these calculations are plotted in Figs. B-6 and B-7 for 50 knots and 80 knot ship speeds, respectively. These figures were then used to calculate diameter and rpm when thrust power is known, and overall propulsive coefficient (OPC), or overall propulsive efficiency, is of the magnitude given in Appendix A. Open water propeller efficiency must be greater than OPC due to the problems discussed in Appendix A. A maximum OPC of 0.6 will be assumed for both 50 knot and 80 knot ships using supercavitating propellers.

Propeller Operating Region Criteria

The ability of a marine propeller to achieve in actual practice, the performance level demonstrated in tests, depends on the particular pressure conditions under which it operates. In some cases, a propeller will be operated under conditions where partial cavitation occurs. In these circumstances, the efficiency of the propeller will be degraded from that corresponding to test data.

The suitability of the propellers selected for this study were checked by investigating the operating regions for the various ship design points of interest. The results of this investigation are presented in Fig. B-8. In this figure, the cavitation index is plotted against the advance ratio for various ships (characterized by maximum speed), and at various design point propeller efficiencies for both CRP and FP propellers. Regions of partial cavitation, as well as regions of best

operation for subcavitating and supercavitating propellers are indicated in this figure. The boundaries for these regions were based on information from Ref. B-3 where the propeller cavitation index is computed by assuming a typical 5 ft submergence depth of the propeller hub and a sea water vapor pressure of 350 psf.

The results of this figure show that the propeller performance demonstrated by the performance maps of Refs. B-1 and B-2 can be achieved without partial cavitation by 26 knot auxiliary ships and by 80 knot high performance (HPS) at all expected operating conditions. For 35 knot ships, propellers designed for high efficiency ($\eta_o = 0.75$) would probably operate without cavitation and achieve the performance predicted by tests, whereas, lower-efficiency designs would be operating in a partial cavitation region where attainment of the predicted efficiencies could be questionable. In a 50 knot destroyer application, supercavitating propellers designed for efficiencies lower than 0.75 would operate in the proper supercavitation region and likely would achieve the performance predicted by the series tests. The high-efficiency propeller designs possibly would operate in partial cavitation and thereby will not be able to attain expected efficiencies.

In Fig. B-8, only the conditions for design point maximum speeds are shown. At lower speeds the Advance Ratio (J) decreases while the cavitation index increases, and therefore, the points shown would move upward and to the left, approximately paralleling the boundary for the partial cavitation region. Hence, for almost all cases, the off-design points would tend to be located in a favorable region as are those at the design point condition. An exception could be that for the 50-knot destroyer where design points located in the supercavitating region might move into a region of partial cavitation at very low speeds.

From this analysis, it is concluded that the performance predicted for subcavitating and supercavitating propellers in Refs. B-1 and B-2 can be achieved by ships under all operating conditions without undesirable partial cavitation. To further assure this result is achieved in actual practice, subcavitating propellers designed for high, open-water efficiencies should be selected for 35 knot ships, while for supercavitating propellers, designs with efficiencies below 0.75 should be used for 50 knot destroyers.

Water Jet Performance

The service efficiency attained by water jets is affected by many more factors than in propellers. Inlet geometry, ducting configuration, nozzle efficiencies, internal frictional losses, and stage interactions are just a few of the additional considerations that can affect performance. Consultations with Dr. P. Mandel of MIT and open literature such as Ref. B-4 have indicated that water jets may not provide the same overall propulsive coefficient as supercavitating propellers. Consequently it is projected that water jets will be able to provide an OPC not greater than 0.55 for 50- and 80-knot ships.

Comparison of Performance Prediction to Actual Data

The propeller characteristics presented in Figs. B-3, B-4, B-6 and B-7 were compared to actual ship installations and conceptual designs such as given in Ref. B-5. Actual data for both 26-knot and 35-knot propellers were found to agree well with the estimates for diameter and rpm made from these figures. This agreement is seen in Fig. I-9 in the text for the 35-knot ships. However, for 50- and 80-knot ships the actual installed or conceived rpm data plotted in this figure digresses significantly from the theoretical prediction trendlines. Therefore, the average lines shown in Fig. I-9 were used to determine thruster rpm in this study.

In the cases of 50- and 80-knot ships only one curve was used to determine rpm for both of these velocities. This single relationship may not be true in the future designs, but currently the optimum service rpm appears to be somewhat unpredictable and this compromise seems a reasonable and simplifying assumption for this type of study.

The actual operating rpm of water jets appears to be even less defined at present than supercavitating propellers. Water jets with 2 or more internal shaft speeds introduce other complicating factors, such as the necessity of an additional gearbox. Actual data for the initial input rpm to water jets (seen in Fig. I-9) falls in the same general region as supercavitating propellers and hence the same trendline is selected for water jet rpm as well.

Off-Design Performance

The process of matching thruster operation to the off-design engine operating characteristics is extremely complex and normally, is handled by means of computer programs (Refs. B-6 and B-7). However, extensive computations for this type design function were considered unwarranted for this present study, and therefore, a simplified procedure was developed.

This simplified approach is based on the fact that the thrust coefficient at any operating condition defines the propeller loading and in general determines the locus of operating points on the propeller performance map. The thrust coefficient

at any off-design condition (after propeller diameter and shaft speed have been selected for a particular design point condition) then is proportional to the term THP/V^3 defined previously. By using this relationship, and the ship power-speed relationship from Fig. I-5, the thrust coefficient at off-design speeds (when normalized to the design point maximum speed) can be plotted as a function of the ratio of off-design velocity to maximum velocity as illustrated in Fig. B-9. This information was then used to calculate off-design performance at extreme conditions according to the procedure explained in the following paragraphs.

Examination of the propeller performance maps presented in Refs. B-1 and B-2 would show that for a CRP propeller, a desired thrust coefficient (K_T or C_T) can be achieved at different advance ratios (i.e., different speeds) corresponding to different levels of efficiency. In this simplified approach, combinations of propeller efficiency and the corresponding advance ratio were read from the performance maps of Refs. B-1 and B-2 for a range of off-design thrust coefficients. These off-design thrust coefficients cover the range presented in Fig. B-9 and represent extreme conditions, ranging from values at the design point for open-water propeller efficiencies of 0.7 and 0.75, (obtained from the selected design parameters of Figs. B-2 and B-5) to 60 percent of these values. Results for off design efficiency based on this approach are presented in Fig. B-10 as function of advance ratio for subcavitating and supercavitating propellers.

For subcavitating propellers, the range of off-design conditions derived from Fig. B-9 plot close together to allow selection of single curve of maximum efficiency versus advance ratio, J . For supercavitating propellers, the actual off-design data in Fig. B-10 do not produce a single relationship for the maximum efficiency envelope. That is, when the thrust coefficient is kept constant near maximum value, the data points match the maximum envelope curve at low advance ratio. However when thrust coefficient is smaller, the data deviate from the maximum envelope curve at both lower and higher ends of advance ratio. Because of this phenomenon, an average curve was drawn between the extremes of the envelope for use in this study.

When applied to actual ship operation, off-design efficiencies also become affected by changes in flow conditions entering the plane of the propeller. Such effects can be particularly significant for supercavitating propellers on high speed ships where the difference between maximum speed and loiter speed is large. In the case of water jets, measures such as incorporating variable inlet geometry are being used to accommodate such problems. Since this study is also concerned with fuel consumption rate of the ship, the total change in propulsive efficiency (or OPC), not just thruster efficiency must be estimated. The results presented in Fig. B-10 were, therefore, cross-checked with consultants opinions and open literature predictions such as presented in Ref. B-8, to generate the off-design power requirements shown in Fig. I-12 which was used in this study.

Thruster Weight Estimation

Thruster weights were established from two sources. The propeller diameter required to provide the performance selected was used to estimate weight from a relationship which accounts for material and type of propeller. Water jet weight was estimated directly from a relationship with input power.

Propeller Weight Estimation

A survey was taken of available data for operational and conceptual design propeller weights (Ref. B-5, B-9, B-10) and compared to a relationship shown in Ref. B-3. Relationships were then selected which are shown in Fig. I-11 (in the text) where propeller weight can be estimated from known diameter and material used for both FP and CRP propellers. These correlations include relationships for 3-, 4-, and 5-bladed propellers for combat ships, tankers, cargo vessels, and high performance ships which are made from materials such as bronze, titanium and stainless steel. The need for a pitch change mechanism and often larger hubs in CRP propeller design is also accommodated in these relationships.

A distinction is also noted between curves for propellers larger than 8 ft in diameter, and the single shallow curve which should be used for diameters under 8 ft (which are generally applicable to high speed ships). Propeller diameters were also checked against limits suggested by Dr. Mandel as shown in Table I-5.

Water Jet Weight Estimation

Establishing an estimating procedure for the relationship of water jet weight to performance is difficult since this form of propulsion is still in the developmental stage with changing technological status, and the weight of related equipment (inlets, ducts, nozzles) as well as the trapped water can be significant. However, limited actual installation data and conceptual design projections such as given in Ref. B-4 and B-11 indicate that the extension of a relationship presented in Ref. B-12 appears reasonable. This relationship which is also presented in Fig. I-11 indicates that the weight of water jets (without ducting or water) is on the order of 0.75 to 1.0 lbs/shp. The weight of ducting and entrained water would be determined by a more specific ship design than is reasonable for this study but would have to be minimized to allow use of this concept.

APPENDIX C

GEARBOX WEIGHT AND VOLUME ESTIMATION

Gearbox weight and volume as installed on current ships often approach and even exceed the weight and volume of the gas turbine engines, as demonstrated by the DD963 and FFG-7. In comparison, gearbox weight and volume for high-speed ships are often only one-tenth as large. Thus to allow meaningful predictions for propulsion system weight, a method compatible with these differences was established and utilized. It is the purpose of this appendix to describe these estimating procedures.

Weight Estimation

The difference in specific weight between the examples cited above is due primarily to three factors: output shaft speed, reduction ratio between input and output shafts speeds, and design philosophy. Equations expressed in terms of these factors were developed to estimate the weight of several gear arrangements most likely to be needed for the ship types considered.

Output shaft (thus thruster) speeds varied from 100 to 2000 rpm in this study. The lower thruster speed requires extremely high torque to achieve thruster power as high as 100,000 shp. The higher thruster speeds allow output gears to transmit lower torque for the same power, hence smaller and lighter gearboxes result.

Reduction ratio also dictates gear geometry as well as absolute size when gear tooth loading is limited. In epicyclic gearboxes, reduction ratio also causes spatial limitations on the number of planets which can share the load, as shown in Table C-1, and this can severely effect weight and size.

Design limits on allowable gear tooth stress (both compressive and bending) also affect size and weight. These stress limits are dependent on the conditions under which the gear is expected to operate. If a smooth continuous flow of power is required, such as a turbine driving an electric generator, the allowable steady-state stress limits may be higher than in an application which is subject to severe vibration and shock loading, such as a diesel-powered commercial ships. Naval combat ships are much more weight sensitive than commercial vessels, and therefore, decreasing the stress limit to safeguard the severe shock loading associated with the ocean environment must be compromised with increasing the stress limit to favor weight reduction of the gear system. A compressive loading factor, the K factor, is often used to establish reference limits for the gearbox design which also allows weight and volume to be estimated. However, this factor does not include consideration of gear tooth bending stress or shape limits which are critical in high torque applications. The method used here considers a load per inch of gear tooth face (lb/in.) in conjunction with the K factor (lb/in./in.) to estimate gearbox size and weight.

Several methods are available in open literature to predict weight and volume, notably the Willis method (Ref. C-1) and the Dudley equations (Ref. C-2). These methods require selection of gear type, reduction ratio, power and the K factor. The Willis method can be used to estimate both weight and volume with good accuracy when the exact geometrical arrangement of the gears in the transmission is known. The Dudley equations do not require knowledge of exact geometry to estimate weight, but are not applicable to complex multiple reduction gearboxes. Since this appendix is not intended to design gearboxes, the method described here is essentially an extension of the Dudley equations to allow estimation of approximate weight for marine gearbox systems.

The basic Dudley equations for weight, $W = (\text{constant})\left(\frac{Q}{K}\right)^x$, has been presented in several versions to predict the weight of a simple single reduction offset gearbox as shown in the upper left of Fig. C-1 (code 1101). A few of these equations are shown below (Ref. C-2):

$$W = (2.9 \times 10^4)(Q/K)^{0.8} \quad \text{for heavy gearbox design} \quad (\text{C-1})$$

$$W = (1.6 \times 10^4)(Q/K)^{0.9} \quad \text{for lightweight gearbox design} \quad (\text{C-2})$$

$$W = (0.95 \times 10^4)(Q/K)^{1.0} \quad \text{for epicyclic gearboxes} \quad (\text{C-3})$$

where:

$$Q = \frac{HP(m+1)^3}{m(\text{RPM})_i} \quad (\text{C-4})$$

m = reduction ratio

$(\text{RPM})_i$ = input shaft speed

HP = input horsepower

$$K = \frac{P_t}{f_a \left(\frac{d_p}{m}\right)} \quad (\text{C-5})$$

where:

p_t = total force exerted tangential to gear pitch diameter (lb)

f_a = active face width of gear tooth, in.

d_p = pinion gear diameter, in.

The form of these equations can be derived from considerations of gear tooth design stress while the exponent is essentially used to represent the trends shown by actual gearbox weight data plotted on log-log paper versus the Q/K factor. Since the data used for Dudley's original equations were based on 1940's vintage information, a check against more recent data was performed. To do this the K factor used by the manufacturer is required, which is unfortunately not readily accessible. Therefore, only limited data was plotted as shown in Fig. C-2 for weight versus the ratio of output power to output shaft speed to check the exponent of the reference equations. When the effect of the K factor is considered for data where K is available, the trendlines formed for epicyclics and single input-single output gearboxes shown in Figs. C-2 and C-3 were found to reasonably agree with the Dudley predictions.

However, data plotted for multiple reduction gearboxes with two or more power inputs and one power output (usually utilizing locked train and quill shaft concepts) indicated quite a different exponent for the basic equation. For the purposes of this study, equations were generated to represent these trendlines which can then be used to estimate gearbox weight. These equations as well as relationships for other complex arrangements (shown in Fig. C-1) are presented in Table C-1. Several of the arrangements, such as codes 1202, 1203, 11e2, or 11e3 have little existing data available and hence a theoretical approximation method was required to establish their weight estimating equations.

The weight and volume characteristics for epicyclics in series (e.g., 11e2) can be estimated by summation of applicable single-stage gearbox data available. However, for the more complex gear arrangement, 1202, an estimation was made by comparing this gearbox to arrangements 2102, 2102R, 1201 and summing appropriate parts of these predictions based on a building block approach.

The basic building block utilized in this approach consisted of two gears in contact whose weight can be predicted by the Dudley equations. A summation of building blocks was made such that the typical gear arrangements shown in Fig. C-1 are accommodated. The characteristic weight of each building block of gears thus depends on the power transmitted per single tooth in contact, the reduction ratio, and the K factor. When the building blocks are added, predictions are generated which agree well with data for single-input, single-output, and multiple reduction gearboxes (1102). For twin input gearboxes (2102) as seen in Fig. C-4, the (Q/K) exponent was selected to agree with actual data for this type. This same adjustment was made to the theoretical equation generated from building blocks for twin output gearboxes (1202) and other complex arrangements. The resultant equations are presented in Table C-1, and plotted in Fig. I-14 of the text.

For bevel gears, limited data is available from hydrofoil installations. However, when this data is included in Fig. C-3 and the recommendation in Ref. C-3 is considered (that bevel gearboxes follow a weight relationship close to the Dudley equation for single reduction gearboxes at $K = 500$), the line indicated in Fig. I-14 for 11b1 seems appropriate to represent this gearbox type as well.

For reversing gearbox types, two assumptions were made: 1) the added weight represents an additional first stage of reduction on each input shaft, 2) supplying as little as half of the input power in reverse is acceptable. These two assumptions yield the resultant relationship shown in Fig. I-14 of the text and is represented by the equation presented in Table C-1. Good agreement was found between this model and the existing data (such as found in the GTS Admiral Callaghan).

When a cruise engine is added to the gearbox, weight will be assumed to increase by an amount equal to an additional single stage reduction gearbox which would match the cruise engine power and speed with the main engine at engine switchover. Generally this will not significantly increase gearbox weight on a conventional displacement ship utilizing offset gearboxes since the input cruise power is typically 5 to 15 percent of total installed power.

As mentioned earlier, the gearbox weight depends strongly on the K factor. In current naval design the K value has often been limited to approximately 200 lb/in./in. while in the future it might be allowed up to 500 lb/in./in. For the present study, a maximum K was chosen as shown in Table I-7 in the text.

Unfortunately, the K factor can not be arbitrarily chosen at a high value since tooth bending stress also depends on the load exerted on a gear tooth. Therefore, a method was established to determine the actual allowable K which would still provide acceptable levels of other design parameters such as a bending stress maximum of 25,000 psi. Tooth load per inch (TL = 3500 lb/in.) can be used as a monitor of this bending stress (Ref. C-4) and when this parameter is combined with fabrication limits on the ratio of gear-face width to gear diameter ($C_f = 2.5$), the maximum output bull gear diameter (25 ft), and the dynamic limit on pitch line velocity (25,000 fpm), the result is an envelope of power transmission limitations dependent on input shaft speed as seen in Fig. C-5.

When these limitations are considered, the allowable K factor can be shown (from the basic relationship of torque and rpm to power) to be a function of power transmitted per tooth, reduction ratio, and the input shaft speed as:

$$K_1 = \frac{(m+1)}{m} \sqrt{8.0504 \times 10^5 (\text{RPM}_1) / \text{HP}_c} \quad (\text{C-6})$$

where K_1 was used instead of K to distinguish this as applying to the input or first stage gears. Equation C-6 was then plotted as shown in Fig. C-5 so that K_1 can be determined for any application and then used in the weight equations given in Table C-1. The gearbox weight can then be easily estimated by utilizing these equations and the K_1 limitations from Fig. C-5 and Table I-7.

The procedures to follow for utilizing these equations to estimate the gearbox weight are outlined as follows:

1. Determine the gearbox performance requirements, e.g., total shaft horsepower (HP_t) to be transmitted through the gearbox, input shaft speed (RPM_i), output shaft speed (RPM_o), and the overall reduction ratio (M).

2. Calculate the single stage reduction ratio (m), where

$m = M$ for single-stage reduction

$m = \sqrt{M}$ for double-stage reduction (C-7)

$m = \sqrt[3]{M}$ for triple-stage reduction

3. Select gearbox type (offset, epicyclic, or bevel) and match the selected gearbox design capabilities with the number of input and output shafts, and with the number of stages of reduction by consulting Table I-6, Table C-1, and Fig. C-1.

4. Calculate power transmitted per tooth in contact (HP_c) from the following definition

$$HP_c = HP_t / b \quad (C-8)$$

where HP_t = total power to be transmitted, shp

b = number of branches given in Table C-1

5. Calculate Q' from the following equation

$$Q' = \frac{HP_c (m+1)^3}{(RPM_o) m^2} \quad (C-9)$$

6. Calculate K_1 from Eq. C-6 where K_1 should not exceed the limits specified in Table I-7 in the text.

7. Calculate Q'/K_1 .

8. Calculate the gearbox weight (pounds) from the appropriate equation given in Table C-1.

Volume and Size Estimation

The volume of an offset gearbox is highly dependent on the center to center distance between the input (pinion) gear and the output (bull) gear centerlines (C). For a simple single reduction offset gearbox, a reference volume (C^2F , where F is the gear face width) can be estimated from the following equation taken from Ref. C-1:

$$C^2F = 3.15 \times 10^4 (m+1)^3 (HP_t) / (b)(K)(m)^2 (RPM_o) \quad (C-10)$$

where C = input-output gear center to center distance, in.

F = gear face width, in.

b = number of teeth sharing the power

RPM_o = output shaft speed, rpm

and HP_t, m, K are the same as defined in Eqs. C-5, C-7, and C-8

For more complex gearboxes the total reference volume can be determined by adding the reference volume for each of the stages of reduction together until all gears are accounted for. Alternatively, equations derived in Ref. C-1 for specific gear arrangements, based on this procedure, can be used directly when applicable.

The size of the gearbox can also be approximated in terms of center distance (C) and the face width (F). Doubling the center distance between the output bull gear and its pinion gear will give a dimension close to the actual gearbox width. Doubling the gear face width of each stage will give an approximate length for that stage while addition of the length required for other stages will approximate the total gearbox length.

APPENDIX D

PROPULSION SHAFT WEIGHT ESTIMATION PROCEDURE

For the purpose of fully characterizing the propulsion system weight, the shaft weight must be considered since it can be a significant fraction of the total weight. Therefore, a model was established which reflects typical ship configurations such that parameters critical to the propulsion shafting can be studied without introducing specific naval architecture variances. Figure I-17 (in text) presents a summary of the model relationship for shaft specific weight versus total installed horsepower for one, two, or four shafts. No more than four primary shafts per ship was considered.

Typical Shaft Configurations

A survey of existing naval shafting was made to establish the relationships between the weight and the shafting configuration. The survey data are presented in Table D-1 and Fig. D-1. In addition, the effect of the limitations of engines and thrusters on shafting arrangements as shown in Table II-7 were considered. For example, five shafts will not be considered since this can be an inconvenient, unorthodox and often impractical arrangement because of the hull shape for many of the ship types considered. Shaft length is thus partially dependent on ship type, draft, breadth and arrangement. But the shaft length of naval combat ships is also affected by considerations of vulnerability and performance when damaged. It can be seen from Fig. D-1 that most combat ships currently in operation can sustain two adjacent flooded compartments in the engine room region and still produce half of total installed power. Bulkhead spacing in and between engine compartments was found to vary from 30 to 70 ft, a factor that is related to the type of damage expected, machinery size, ship size, mission vulnerability, and design philosophy. In addition, single shafted combat ships use a shaft with thicker wall as seen in Table D-1 which also affects weight.

For the purposes of this study, an analytical model established for shaft length is presented in Eq. (D-1) below based on the survey data and layouts shown in Fig. D-2.

$$\text{Shaft length (ft)} = (N_s \times L_s) + (N_c \times L_c) \quad (\text{D-1})$$

where: N_s = No. of shafts per ship

L_s = Shortest shaft length determined from model arrangement (Fig. D-2)

N_c = No. of additional compartments penetrated by subsequent shafts

L_c = spacing between bulkheads, assumed to be 40 ft in the present study

The results of this model were plotted in Fig. D-3 in terms of the total shaft length required versus the installed power which is equally divided among the shafts. This relationship is possible since the installed power at a given speed is a function of displacement (as presented in Section I) while displacement is dependent on length and breadth of the ship which affect possible engine and thruster locations and thus shaft lengths. The survey data were also plotted on the same figure which shows that good agreement is obtained for conventional combat ships. For 50-knot, future displacement ships, with limited hull volume, the length for four shafts is assumed to be equal to double the two shaft length, with each engine room receiving two shafts as shown in Fig. D-2; 50-knot ships with two shafts were assumed to have total shaft length equal to that for 35-knot ships with two shafts of the same displacement.

Surface effect ships normally require that power be supplied to lift producing devices as well as to at least two separately located thrusters since two surface piercing hulls are used and air jet propulsion is often not considered. Furthermore, reliability and vulnerability considerations indicate that cross connection between engines, between thrusters, and between lift producing devices is desirable such that the ship can remain on air cushion at reasonable speeds with partial disabling of power. All these considerations would mean that SES can have complex shaft configurations requiring five or more shafts (two for thrusters, two for lift devices, one for cross connection of engines); but regardless of the specific arrangement of engines, thrusters and lift producing devices, power transmitting shafts interconnecting these three would be needed unless an unconventional method such as chains, cables or ducting of engine compressor air is used to provide lift or thrust as in the Harrier aircraft.

For the purposes of this analysis a simplified SES configuration with only one shaft connecting a prime mover compartment to each of three compartments containing clustered thrusters and lift producing devices was considered. Cross connection was assumed to be possible between the respective compartments. Thus, three primary shafts are probably the minimum requirement. (one for each thruster plus one for combined lift and cross-connection). However, if the engines are clustered near the lift devices as in the SES -100A, -100B, and -2000, then the lift shaft can be short. Total shaft length would then depend strongly on the two thruster shafts lengths. Since these shafts usually do not have a straight run their length could be expected to be a larger fraction of ship length and breadth than in conventional ships. Furthermore, since SES have a smaller length/width ratio and require more power than a conventional ship of the same displacement, the total shaft length might approach that required for a two shaft conventional ship. This approximation was chosen after careful consideration of actual and projected SES shafting data seen in Fig. D-1.

For auxiliary or noncombat ships which travel at slower speeds, both installed horsepower and vulnerability requirements are reduced while hull volume is increased as compared with combat ships of the same displacement (Ref. D-3). These factors tend to counterbalance each other with regard to their effect on total shaft length. Overall, slightly shorter shafting length was assumed for this ship type as plotted in Fig. D-1.

Shaft Weight Estimation

The weight of shafts per unit length is primarily dependent on the allowable shear stress and the ratio of inner to outer diameter of hollow shafts and can be expressed theoretically by the equation shown in Fig. D-4. The usefulness of this expression was verified by plotting data obtained from current Naval ships in Table D-I onto Fig. D-4 and comparing this to the theory at 6000, 10,000 and 12,000 psi shear stress. Published literature (Refs. D-4, and D-5) indicates that current Naval practice is to limit design stress to 6000 to 10,000 psi with the ratio of inner to outer diameters set at 0.60 to 0.68. Since reasonable agreement was obtained between the theoretical lines and actual data, the estimates shown in Fig. D-4 were used in this study for shaft unit weight (lb/ft). The value at a chosen stress limit, rpm and shp, is multiplied by the total shaft length indicated in Fig. D-3 to give total installed shaft weight. Dividing by total installed power gives the shaft specific weight, shown in Fig. I-17.

For conventional displacement ships (26- and 35-knot maximum speed) a limit of 10,000 psi was chosen as representative of an average for safe operation without requiring a major breakthrough in material strength, corrosion resistance, or design philosophy. On high-speed ships (50-knot destroyers) or high-performance ships (SES) a 12,000-psi shear stress limit is used since weight reductions are critical to achieving attractive ship design. When these stress limits are used in conjunction with the lengths from Fig. D-1 and the rpm required by the thruster at the horsepower dictated by the ship type, size, and arrangement shown in Fig. D-2 and Fig. I-9 of the text, the specific weights shown in Fig. I-17 result.

APPENDIX E

STATE-OF-THE-ART PERFORMANCE PROGRAM (SOAPP)

The SOAPP program is a revolutionary and sophisticated computational system which can be used to analyze almost any complex power system configuration consisting of a large number of components. SOAPP could also be used to estimate the design, economic, and environmental characteristics of advanced cycle power systems if desired. The SOAPP system is based on a completely modularized representation of system components. Modularization permits considerable versatility in selecting power system configurations to be analyzed and allows continual update of the system as improved revisions of each module became available. Many revisions of these reprogrammed modules with differing degrees of complexity are stored in an extensive SOAPP library.

The central and unique feature of SOAPP is a preprocessor or precompiler which establishes the sequential logic required for system calculations and performs all detailed programming work necessary for any given configuration. The desired configuration is specified using a simple alphanumeric code, along with specific module and performance map identification codes. The preprocessor then selects the corresponding module and map routines from the library and writes the main control program in FORTRAN which will include all the mathematical logic necessary to provide complete mass and energy balances for the desired configuration. The control program performs all calculations in proper sequence and accounts for iterative balances of design requirements, in and out bleed or extraction streams, external schedules and controls, and transfer of data between modules.

The configuration flexibility described above was the primary goal of SOAPP. Other advantages of SOAPP involve user convenience features such as automatic cycling of run data, data input/output flexibility, and automatic balancing of constraints imposed on parameters at intermediate locations in the system.

The development of SOAPP was done at Corporate expense. The problem solving logic and mathematical routines for SOAPP were developed at UTRC during the late 1960's. The technical module and map routines were prepared by and are continually being updated by P&WA. During the early 1970's, UTRC extended the SOAPP library to include modules for improved heat exchangers, boilers, steam cycles, and fuel gas cleanup systems. SOAPP has been used on a large number of Corporate- and Government-funded projects involving aircraft gas turbines, industrial gas turbines using simple and compound configurations, combined-cycle power systems, integrated coal gasification/combined-cycle power systems, fossil- and nuclear-fueled closed-cycle systems using fluids such as helium and argon, and nuclear-power aircraft gas turbines.

R77-952566-5

The SOAPP library is being continuously updated to provide for more flexibility in simulating advanced power systems. In the mid-1970's, this emphasis has been towards better representation of coal combustors and various coal gasification processes. SOAPP is capable of being flexible enough to serving with the needs of new technology as time goes on.

APPENDIX F

COMPONENT SIZE AND WEIGHT ESTIMATING PROGRAM

Turbomachinery and heat exchanger design practices are based on an extensive amount of empirical data and theoretical analyses which have been accumulated over a period of time. Organizations such as the Pratt & Whitney Aircraft Group and Power Systems Division of United Technologies Corporation maintain large theoretical analysis and experimental engineering staffs who continually update and refine their engine design procedures based on the latest performance data. In a preliminary system analysis of a new power conversion system, it is not always practical to duplicate such extensive engine design efforts. Therefore, within UTRC, a computerized design model is used as a reasonable and practical compromise between a wholly theoretical approach and the extremely detailed design analysis of a specific power conversion system. The ease with which the computer program can be operated allows many component variations to be examined quickly at low cost.

The computer model, which is capable of designing the axial-flow type turbomachinery and tube-in-shell type heat exchanger with various working fluids, is called Component Size and Weight Estimating Program (CSWEP). This program can be operated independently or in combination with the SOAPP program. Many empirical formulas derived from existing data and United Technologies Corporation design experience have been incorporated within the program, thereby allowing two types of input, thermodynamic performance or engineering design point specifications. The thermodynamic performance input data include the working fluid inlet and exit conditions (e.g., pressure, temperature, and mass flow rate) for each component, while the engineering design-point specification consists of material selection, the turbomachinery speeds, mean-blade velocities, stage work coefficients, flow coefficients, heat exchanger tube sizes, and tube arrangements. The primary goal of this program is to estimate the major dimensions and weights of each component of any power conversion system, subject to various operating conditions and design point specifications.

APPENDIX G

GAS TURBINE POWER CONVERSION SYSTEMS COST ESTIMATING PROGRAM

In the course of both Corporate-sponsored and Government-sponsored analytical studies, UTRC has found it necessary to make detailed estimates of the economics associated with the various programs. One subject which has received considerable attention in many of the past programs is the industrial gas turbine since it offers a number of significant advantages relative to systems against which it could compete. As a result, it was decided during the course of the program described in Ref. G - 1 that a computerized analytical approach should be developed which would allow representative estimates to be made of the manufacturing costs of gas turbine engines. The resulting computerized model was applicable to engines of the early 1970-era as typified by the Pratt & Whitney Aircraft Group FT4-type engine design. In 1974, interest in system economic feasibility analysis was extended to be used for utility central power generation or marine propulsion. Because the new industrialized gas turbine designs are radically different from those of aircraft derivation, and because of the versatile application of heat exchangers, a completely new computer cost estimating program was believed to be necessary. Therefore, in early 1975 UTRC undertook a Corporate-sponsored program to develop a second-generation computer model which would be capable of providing detailed manufacturing cost for the major components of both open- and closed-cycle gas turbine engines.

The validity of this program has been substantiated through various sources. For example, in 1975, UTRC concluded a subcontract with NASA-Lewis and Burns and Roe, Inc., to provide estimates of the costs of NASA developed engines considered in conjunction with the ECAS program. As part of this effort, UTRC was required to validate the accuracy of its gas turbine manufacturing cost model by making cost estimates for some selected existing engines, produced by several manufacturers. The results of this test showed a very close correlation between the cost model output and the data provided by NASA on these candidate engines. The UTRC program has also been used to provide budgetary cost estimates on new Corporate designs as well as those from competitor facilities. The correlation between results from the UTRC program and those generated by longer and more detailed efforts by cost analysis groups within United Technologies Corporation show differences of less than ten percent. Since the UTRC computerized program for estimating manufacturing costs is based on detailed correlations developed through contacts with vendors and with United Technologies Corporation personnel, it represents a logical extension of the analytical capabilities to provide optimized thermodynamic performance information (the sOAPP program) and size estimating capabilities.

The computerized program for estimating the manufacturing costs of closed-cycle gas turbine engines is divided into several major components including the turbomachinery, heat exchanger, and ducting. Within each of these sections, the costs of the major part are estimated in detail; costs for minor parts such as fasteners, spacers, and other miscellaneous parts are grouped together as one single estimate at the end of the calculations. The estimates provided are believed representative of those at the end of the factory production line, including all overhead rates and variances typical of a heavy equipment manufacturing organization.

Turbomachinery

Compressor Vanes, Blades and Disks

Major suppliers of industrial and aircraft gas turbine engine compressor blades were contacted to obtain cost data from which correlations were made of compressor blade costs with airfoil lengths to 20 in. and aspect ratios as high as 3.0. For a basic AMS 5616 (Greek Ascoloy) material, correlations were derived for the blade material cost which, based on experience, was found to constitute approximately 35 percent of total blade cost with labor comprising the remainder. Correlations were then derived for blades whose material specification is other than AMS 5616. This requires changing the material cost correlation and modifying the labor fraction based on a machinability index. Each blade row in the compressor is considered individually, and respective unit costs are multiplied by the stage airfoil count to determine total blade costs per stage.

An approach similar to that described for compressor blades is also employed for the compressor vanes and vane sections with one major exception. Since the vanes were assumed to be cast, their labor content does not vary significantly with material choice for a given airfoil length. Therefore, the major change in compressor vane cost is with the selection of vane material and the number of vanes per stage. A stage-by-stage analysis similar to that described for the compressor blades is used in the model. However, a different design philosophy is assumed for the respective low and high sections: a shrouded vane assembly comprised of several segments is assumed for low-compressor sections; whereas a cantilevered vane design is assumed appropriate for the normally shorter, high-compressor vanes. Any additional difference in costs of equal-length airfoils located in the high or low sections is attributable to attachment features in the respective sections.

Provisions are made in the model for estimating the costs of variable inlet guide vanes if such are a part of a particular engine design. All associated attachments and variable mechanical controls are considered and these individual component costs are summed and presented as a single value for that section.

An extensive investigation into total manufacturing costs of compressor disks at both vendor and Corporate facilities revealed that material costs are related to disk volume, geometry, and material choice; whereas labor costs relate to geometry (primarily to surface area) and material machinability. The disks associated with each stage are considered individually within the computer model. This individual consideration is necessary in order to account for the variations which exist between the disks such as size, sequential location (a factor which affects geometry), and material. In the same set of correlation equations, estimates are also made for the production costs of the hubs, where required.

Turbine Blades, Vanes, and Disks

A distinction is made in the computer model between cooled and uncooled turbine blades. For the uncooled blades, the material cost portion follows a similar relationship to that used for compressor blades; that is, the cost is related to the material choice and the airfoil size. As previously stated, this material portion of the blade cost has been found to average approximately 35 percent of the total blade cost; the labor portion comprises the remainder. Corrections to the labor portion are made based on the machinability of the subject material relative to that of IN 718, a high-nickel-content superalloy. For cooled turbine blades, the total manufacturing cost is also divided into labor and material portions, the labor portion of which constitutes approximately 78 percent of the total manufacturing cost. A distinct equation defines the material cost based on material choice and physical airfoil dimensions. Corrections to increase the labor content are made only in cases where the turbine blades are shrouded designs.

Separate calculation procedures are undertaken to estimate the total manufacturing costs of both cooled and uncooled turbine vanes. Although the basic equation coefficients differ from those employed in the turbine blade section, the general procedure of dividing the total manufacturing cost into labor and material components is still followed. The general design of the turbine vanes assumes that the airfoil is shrouded at both its inner and outer ends, and as a result the unit manufacturing cost correlations differ quite radically from those applied to blades of similar airfoil dimensions.

The disk costs for the gas generator and power turbine sections vary primarily as the disk volume (the material portion) and the surface area (the labor portion). The general shape of the turbine disks are similar from stage to stage, but on a whole, vary considerably from those which would be used in the compressor section of an engine. Disk diameter is related to the amount of gas flow, the rotational speed, and the work requirements; whereas disk width at both rim and hub are a function of the size and shape of the attached airfoil blade. Hubs, where required, are included as a part of the cost estimates of the disk section, and the costs of these hubs are estimated individually, their value depending primarily on hub dimensions and material.

Power Turbine Blades and Vanes

To date, there has been no requirement for cooled airfoils in the power turbine section of advanced industrial-type gas turbine engines. Furthermore, no requirement is foreseen for engines produced in the next ten years to incorporate cooled power turbine airfoils. As a result, the computer model only provides for solid, uncooled blades and vanes in the power turbine section. Because of their large physical sizes, the airfoil correlation equations differ from those used in previous turbine sections. Material cost is assumed to average 35 percent of the total cost, and labor comprises the remaining 65 percent. Experience and observations have revealed there is considerable amount of labor involved in the production of each of these large airfoils, and because of their high exotic material content, machine-associated labor time often can be considerable. Allowances similar to those applied to other airfoils are made for variations about a standard blade labor cost allowance to account for differing material machinabilities.

Turbomachinery Casing

The engine casing is comprised of several separate sections, the sizes of which are related to each of the major respective areas (compressor, burner, etc.) of the engine. The assumption made for modeling purposes is that the engine case material is a low-carbon-steel type (ASTM A216, A515, or similar) throughout the entire length of the engine. The physical dimensions of the case, in addition to being related to the particular component contained within at each point, are also based on the pressure of the working fluid in that section. A conservative 5000 psi hoop stress is assumed, and the total cost and machined case in terms of mid-1976 dollars is estimated at \$2.30 per pound of finished material. The length of each case section depends, of course, on the section to which each is related, and sufficient allowances are made for extra length at transition locations to match with adjoining case sections.

Turbomachinery Shafts

In a twin spool engine with power turbine, only two shafts are specified: that between the low compressor and low turbine and that required for the power turbine. The shaft between the high compressor and high turbine is actually only comprised of the respective rear and front hubs of these sections, where the costs for each already have been discussed above. An analysis of present industrial-type engine designs revealed a consistent relationship between the shaft diameter and the size of the compressor or turbine stage to which the shaft is attached. This is reasonable since shaft size is primarily related to transmitted power (stage size) in large engines whose rotational speeds do not vary significantly from model to model. Therefore, in the manufacturing cost model, the shaft diameter and wall thickness are estimated as fixed percentages of the hub diameter of the stage. The length of the shaft is a function of engine size (number of stages, burner length, etc.). The finished manufacturing cost is based on a dollars-per-pound charge, an approach which makes it possible to escalate cost when general cost increases in the industry so dictate.

Turbomachinery Bearings

Bearing vendors were requested to provide cost estimates of large, industrial-type bearings which could be incorporated into advanced gas turbine designs. These estimates were requested for ball and roller antifriction bearings, and sleeve and thrust plain bearings produced from M-50 hardened steel in quantities thought to be representative of those required to support a moderate level of engine production. Excellent graphic correlations were found to exist for cost based on bore diameter and bearing type. As a result provision is made in the computer model to specify bearing type and location at eight points throughout the engine. In this manner, the choice of bearing type and location remains in the exogenous control of the investigator providing added flexibility.

Miscellaneous Items

As it can well be appreciated, it is nearly impossible to undertake cost correlations for the multitude of small fasteners, subcomponents, and unique one-of-a-kind items which constitute a portion of each major section of an engine. As a result, an allowance of slightly more than 17 percent (of total engine manufacturing cost) is allowed for those miscellaneous items which comprise this category of miscellaneous parts. Since these parts are distributed throughout the entire engine, it is difficult to allocate any fraction of their total to a particular engine section.

Specific allowances are, however, made for three other well-defined components of total engine manufacturing cost: fuel control; assembly and test of the complete engine; and quality inspection (primarily x-ray of components) on a routine basis. The estimated cost of the fuel control is an exogenous variable dependent primarily on system size and complexity. Assembly and test charges, in mid-1975 dollars average \$65,000 to \$70,000 for open-cycle gas turbine engines in the 25 MW to 35-MW range and \$85,000 to \$95,000 for those open-cycle units in the 100 MW range. Quality control/x-ray costs are estimated at approximately 15 percent of assembly and test expenses.

Manufacturing Cost Estimate

Care should be exercised in interpreting the results generated by this manufacturing cost computer model. As noted, it is intended for rapid-turnaround analyses, and as such, it is not intended to supplant the detailed analysis required when a specific engine is being investigated. Although the model is directed toward a basic core engine assembled by a typical gas turbine manufacturer, additional components such as inlet plenum, exhaust ducts, external piping, and supports, for example, also constitute a part of the total unit cost. However, since these components most often are a function of a particular application, and they are engineered accordingly, their respective costs are best accommodated manually outside the computer model.

No mention has been made directly concerning unit selling price primarily because price determination depends on numerous conditions including market size, timing of sales, development costs, special write-off of production equipment, the extent of competition, and desired profit margins. Although estimates of selling prices were made in this program, these are based on historical trends and market correlations. It must be appreciated that a realistic estimate cannot be made without at least a preliminary venture analysis directed toward a particular design of interest.

Heat Exchangers

Heat exchanger manufacturers are generally reluctant to provide cost information on hypothetical heat exchanger designs. Therefore, it was necessary to use past experience and engineering judgment to establish a procedure for estimating the cost of standard heat exchangers based on the total heat transfer area required. It is known that costs are very sensitive to special requirements (heat exchanger type, materials, working fluid temperature and pressure, fabrication complexity, and reliability). Adjustment factors available from the Heat Exchanger Design Handbook (Refs. G-2 to G-4) were compiled, curve-fitted, and implemented in a separate heat exchanger model computer program. The shell-and-tube exchanger with carbon-steel and floating head construction was chosen as the standard (reference) design. The cost of any special design type such as the kettle reboiler, U-tube, and fixed tube-sheet can be obtained by applying adjustment factors to the cost of reference design. In view of the potential application of the computer model to higher temperature and pressure cases, it was recognized that special fabrication methods and/or higher strain materials might be needed. Accordingly, adjusting factors for internal fluid pressures ranging from 100 to 2000 psi and for materials including cupro-nickle stainless steel, monel, hastelloy X, and titanium were incorporated into the program. The fabrication complexity factor including provisions for incorporating varying tube diameters (0.25 to 1.5 inch OD), finned tubes, and different pitch arrangements. Finally, since prices tend to change from time to time, the Nelson Cost Index table for heat exchangers was employed to establish the escalation factors to bring the estimates up to a 1976 dollar basis.

Ducting System

Major steel piping supplies were consulted to obtain the cost correlation data for various duct materials and sizes. The cost of the ducting system was found to be estimated best by using dollar per pound of finished material. The finished weight for a selected material depends on the pipe diameter, total length, wall thickness which is a function of the working fluid pressure. In turn, the material selection for a CCGT power conversion system depends on temperature and corrosion limitations. For preliminary cost estimating purposes, the CCGT design has been divided into four sections (as shown in Table IV-4); 1) from turbine exit to regenerator (high temperature and low pressure); 2) from regenerator outlet to

R77-952566-5

compressor inlet (low temperature and low pressure); 3) from compressor exit to regenerator (high pressure and low temperature); and 4) from regenerator outlet to turbine inlet (high temperature and high pressure). In each section, the required wall thickness was established based on a value of two-thirds of the yield stress at the 0.2 percent creep condition for the operating temperature. For piping sizes larger than twelve inches a cost adjustment factor was derived empirically from the available literature information.

REFERENCES FOR APPENDICES

FOR APPENDIX A

- A-1. Marine Engineering, Volume 1, Society of Naval Architects and Marine Engineers. 1955.
- A-2. Blackman, R. V. B. (Ed): Jane's Fighting Ships. McGraw Hill, 1976, 1975, 1972, 1970, 1965.
- A-3. Morison, S. L., and J. S. Rowe: The Ships and Aircraft of the U. S. Fleet. 1975.
- A-4. Jane's Surface Skimmers. McGraw Hill. 1976.
- A-5. Riddel, F. R.: Survey of Advanced Propulsion Systems for Surface Vehicles. Institute for Defense Analysis. January 1975. Paper #P-1073 IDA Log No. HQ 75-16706.
- A-6. Mandel, P.: Consultations at Massachusetts Institute of Technology.
- A-7. Seng, W. R.: Personal Discussions. Office of Naval Research. June 1976.

FOR APPENDIX B

- B-1. van Manen, J. D.: The Choice of the Propeller. Marine Technology, April 1966.
- B-2. Hecker, Richard: Engine Propulsion Matching for High-Speed Craft. Automotive Engineering Congress. January 10-14, 1972. Paper 720279.
- B-3. Mantle, P. J.: A Technical Summary of Air Cushion Craft Development. David W. Taylor Naval Ships Research and Development Center, October 1975 AD-A022 583.
- B-4. Barr, R. A., and Robert J. Etter: Selection of Propulsion Systems for High-Speed Advanced Marine Vehicles. AIAA/SNAME Advanced Marine Vehicles Conference, San Diego, California. February 24-28, 1974. Marine Technology, January 1975.
- B-5. Comstock, J. P. : Principles of Naval Architecture. The Society of Naval Architects and Marine Engineers. 1967.

REFERENCES (Cont'd)

- B-6. Kroegar, N. Bernard Jr. and Damon E. Cummings: Subcavitating Propeller Design for Maximum Propeller Efficiency or Minimum Fuel Use. Marine Technology, April 1974.
- B-7. Stewart, Alan J.: Comparative Performamnce of High Efficiency Ship Propulsion Systems for Destroyer Hull Types. Volume II, Appendices, Bradford Computer and Systems, Inc., December 6, 1974.
- B-8. Von Schertel, Baron Hanns: The Design and Application of Hydrofoils and Their Future Prospects. Transactions of Institute of Marine Engineers. Vol. 86, Series A, Part 3. 1974.
- B-9. Denny, S. H., H. A. Themak and J. J. Nelka: Hydrodynamic Design Consideration for the Controllable-Pitch Propeller for the Guided Missile Frigate; Naval Engineers Journal, April, 1975.
- B-10. DuCane, Peter: High-Speed Small Craft, Temple Press Books, Ltd., London 1964.
- B-11. Perkins, W. F., Jr.: Discussion Notes for a Review of Progress in Design of Large SES. Marine Technology, July 1975.
- B-12. Kim, Hon Choi: Hydrodynamic Aspects of Internal Pump-Jet Propulsion. Marine Technology, January 1966.

FOR APPENDIX C

- C-1. Chironis, N. P.: Gear Design and Application. McGraw Hill. 1967.
- C-2. Dudley, D. W.: Gear Handbook. McGraw Hill. 1962.
- C-3. Muench, R. K.: Arctic Surface Effect Vehicle Program Parametric Data on a Mechanical Transmission Suitable for Large SEV. Sponsored by Defense Advanced Research Projects Agency ARPA #2251 Program Code # 2No0 VSRDC Propulsion and Auxiliary Systems Dept. Annapolis. December 1973. NTIS AD 915-494L.
- C-4. Balukjian, H.: A Computerized Method for the Preliminary Design of Main Reduction Gears. Naval Engineers Journal. February 1972.

REFERENCES (Cont'd)

FOR APPENDIX D

- D-1. Consultations: Visit to NAVSEC; 6-21-76 and Blueprints Nos. CVA 63203-1682103 AOE-3-203-2287732, AOE-1-203-1916690, DL 203001, DD 203007, DD 931-137-4121, DD-445, DLGN-38, CVAN-68-203-4364808.
- D-2. Payne, C. N.: Naval Turbine Propulsion Plants. U. S. Naval Institute 1958.
- D-3. Milne, P. A. and M. F. Craig: Future Developemnts in Machinery Installations. Trans. Inst. Marine Engineers. 1975. Vol. 87.
- D-4. Muench, R. K.: Arctic Surface Effect Vehicle Program Parametric Data on A Mechanical Transmission Suitable for Large SEV. Sponsored by Defense Advanced Research Projects Agency ARPA No. 2251, Program Code No. 2N10 NSRDC Propulsion and Auxiliary Systems Dept., Annapolis. December 1973, NTIS AD 915-494L.
- D-5. Anon: Interim Design Data Sheet Propulsion Shafting - DDS4301. January 1, 1960 Dept. of the Navy, Bureau of Ships.

FOR APPENDIX G

- G-1 Robson, F. L. et al: Technological and Economic Feasibility of Advanced Power Cycle and Methods of Producing Nonpolluting Fuels for Utility Power Stations. NAPCA Contract CPA 22-69-114, December 1970.
- G-2 Fraas, A. P. and M. N. Oaisik: Heat Exchanger Design, Appendix H9, John Wiley & Sons, N. Y. (1965).
- G-3 Fraas, A. P.: Heat Exchangers for High-Temperature Thermodynamic Cycles, ASME Winter Annual Meeting, Houston, Texas, December 1975.
- G-4 Guthrie, K. M.: Process Plant Estimating Evaluation and Control, Craftsman Book Company of America, 1974.

TABLE A-1

U.S. NAVAL SHIP CHARACTERISTICS

ST = Steam Turbine D = Diesel B = Boiler
 GT = Gas Turbine N = Nuclear

Type & Class	Ident. No.	Full Load Disp. (long tons)	Length Overall (ft)	Prime Mover # Type	No. Shafts	Inst. Power (1000's shp)	Speed (Knots)
<u>Aircraft Carrier</u>							
Nimitz	CVAN-68	91,400	1092	2 N	4	280	30+
J.F. Kennedy	CV-67	87,000	1047	8 N, 8B	4	280	30+
Enterprise	CVAN-65	89,600	1102		4	280	30+
Kitty Hawk	CV-63	80,800	1046	4ST, 8B	4	280	30+
Forestal	CVA-59	78,000	1040	4ST, 8B	4	260	30+
Midway	CVA-41	64,000	972	4ST, 12B	4	212	30+
Hancock	CVA-19	44,700	899	4ST, 8B	4	150	30+
Intrepid	CVS-11	42,000	899	4ST, 8B	4	150	25+
Essex	CVS-9	40,600	890	4ST, 8B	4	150	30+
<u>Battleships</u>							
Iowa	BB-61	57,950	887	4ST, 8B	4	212	33.5
<u>Cruisers</u>							
Virginia	CGN-38	10,000	585	2N, 8B	2	-	30+
California	CGN-36	11,100	596	2N, 8B	2	-	30+
Truxtun	CGN-35	9,000	564	2N, 8B	2	60	29
Belknap	CG-26	7,940	547	2ST, 4B	2	85	32.5
Bainbridge	CGN-25	8,590	565		2	60	29
Leahy	CG-16	7,800	533	2ST, 4B	2	85	32.7
Albany	CG-10	18,950	674	4ST, 4B	4	120	30.4
Long Beach	CGN-9	16,247	721		2	80	30

TABLE A-1 (Continued)

Type & Class	Ident. No.	Full Load Disp. (long tons)	Length Overall (ft)	Prime Mover # Type	No. Shafts	Inst. Power (1000's shp)	Speed (knots)
Providence	CG-6	15,200	610	4ST, 4B	4	100	32
Galveston	GLG-3	15,142	610	4ST, 4B	4	100	30.6
Des Moines	CA-134	20,950	716	4ST, 4B	4	120	31.5
Boston	CA-69	17,820	674	4ST, 4B	4	120	33
Baltimore	CA-68	17,350	674	4ST, 4B	4	120	31
<u>Destroyers</u>							
Coontz	DDG-40	5,800	513	2ST, 4B	2	85	33
Mitscher	DDG-35	5,155	494	2ST, 4B	2	80	32
Decatur	DDG-31	4,150	418	2ST, 4B	2	70	31
Charles F. Adams	DDG-2	4,500	437	2ST, 4B	2	70	30
Spruance	DD-963	7,800	563	4GT	2	80	30+
Hull	DD-945	4,050	418	2ST, 4B	2	70	33
Forrest Sherman	DD-931	4,050	418	2ST, 4B	2	70	33
Carpenter	DD-825	3,459	391	2ST, 4B	2	60	33
Gearing	DD-710	3,512	391	2ST, 4B	2	60	32.2
Allen M. Sumner	DD-692	3,300	376	2ST, 4B	2	60	32.5
LaVallette	DD-448	3,040	376	2ST, 4B	2	60	35
<u>Frigates</u>							
Olivr. Hzd. Prry	FFG-7	3,400	440	2GT	1	41	30
Brooke	FFG-1	3,426	414	1ST, 2B	1	35	27.2
Knox	FF-1052	4,100	438	1ST, 2B	1	35	27
Garcia	FF-1040	3,403	414	1ST, 2B	1	35	27.5
Bronstein	FF-1037	2,710	372	1ST, 2B	1	20	24
<u>Patrol Combat</u>							
Pegasus	PHM-1	239	147	1GT+2D		18	40+
Asheville	PG-84	245		1GT+2D	2	13	37.5

TABLE A-1 (Continued)

Type & Class	Ident. No.	Full Load Disp. (long tons)	Length Overall (ft)	Prime Mover # Type	No. Shafts (1000's shp)	Inst. Power (1000's shp)	Speed (Knots)
<u>Command Ships</u>							
Wright	CC-2	19,570	684	4ST, 4B	4	120	30.8
Northampton	CC-1	17,204	676	2ST, 4B	4	120	32
<u>Amphibian Warfare</u>							
Blue Ridge	LCC-19	18,000	620	2ST, 2B	1	22	20
Tarawa	LHA-1	39,300	820	4ST, 2B	2	140	24
Charleston	LKA-113	20,700	550	1ST, 2B	1	22	16
Tulare	LKA-112	16,818	564	2ST, 2B	1	22	23.4
Francis Marion	LPA-249	16,838	564	2ST, 2B	1	22	22.4
Paul Revere	LPA-248	16,838	564	2ST, 2B	1	19	22.5
Austin	LPD-4	16,800	569	2ST, 2B	2	24	21
Raleigh	LPD-1	14,651	521	2ST, 2B	2	24	20
Anchorage	LSD-36	13,700	555	2ST, 2B	2	24	20
Thomaston	LSD-28	11,525	510	2ST, 2B	2	24	22.5
<u>Combatant Craft</u>							
High Point	PCH-1	110	116	2GT+2D	4	62	45
Flagstaff	PGH-1	57	74	GT	1	36	40
<u>Auxiliary Ships</u>							
Sam Gompers	AD-37	20,700	645	1ST, 2B	1	20	18
Kilauea	AE-26	19,937	564	2ST, 3B	1	22	20
Mars	AFS-1	16,263	581	1ST, 3B	1	22	20
Compass Is.	AG-153	16,076	563	1ST, 2B	1	19	20
Plainview	AGEH-1	320	212	2GT+2D	2	28	50
LaSalle	AGF-3	13,900	521	2GT, 2B	2	24	20
Glover	AGFF-1	3,575	415	1ST, 2B	1	35	27
Arlington	AGMR-2	19,800	684	4ST, 4B	4	120	32.5
Sea Lift	AKR-9	21,700	540	2ST, 2B	2	19	20
-----	AO-177	27,500	588	1ST, 2B	1	24	20

TABLE A-1 (Continued)

Type & Class	Ident. No.	Full Load Disp. (long tons)	Length Overall (ft)	Prime Mover # Type	No. Shafts	Inst. Power (1000's shp)	Speed (Knots)
Sealift Pac.	AO-168	32,000	587	2D	1	15	26
Am. Explorer	AO-165	31,300	615	1ST, 2B	1	22	20
Maumee	AO-149	32,953	620	1ST, 2B	1	20	18
Neosho	AO-143	38,000	655	2ST, 2B	2	28	19
Sacramento	AOE-1	52,483	793	2ST, 4B	2	100	26
Wichita	AOR-1	38,100	659	2ST, 3B	2	38	20
L.Y. Spear	AS-36	22,640	644	1ST, 2B	1	20	20
Simon Lake	AS-33	21,000	644	1ST, 2B	1	20	18
Lexington	CVT-16	42,000	899	4ST, 8B	4	150	28
<u>U.S. Coast Guard</u>							
Hamilton	WHEC-715	3,050	378	4GT+2D	2	36	29
Polar Star	WAGB-10	12,000	399	4GT+6D	3	78	17
Glacier	WAGB-4	8,449	310		2	21	17.6

TABLE A- 2

USSR NAVAL SHIP CHARACTERISTICS

ST = Steam Turbine D = Diesel B = Boiler
 GT = Gas Turbine N = Nuclear E = Electric

<u>Type & Class</u>	<u>Full Load Displ (1.t.)</u>	<u>Length Overall (ft.)</u>	<u>Prime Mover</u>	<u>Inst. Power (1000 shp)</u>	<u>Speed (Knots)</u>
<u>Aircraft Carrier</u>					
Kuril	38,000	925			30+
Moskva	18,000	625	ST,4B	100	30
<u>Cruiser</u>					
Kara	10,000	570	GT		34
Kresta II	7,500	520	ST,4B	100	33
Kresta I	6,500	510	ST,4B	100	34
Kynda	6,000	466	2ST,4B	100	35
Sverdlov	19,200	656	ST,6B	130	34
Chapaev	15,000	660	ST+D,6B	130	36
Kirov	9,060	614	ST+D,6B	113	34
<u>Destroyer</u>					
Krivak	4,200	405	8GT	112	38+
Kashin	5,200	471	8GT	96	35
Kildin (Kotlin)	4,000	415	ST,4B	72	36
Kanin (Krupny)	4,600	457	2ST,4B	80	34
Krupny	4,650	452	ST,4B	80	34
Kotlin	3,885	415	ST,4B	72	36
Skory	3,500	395	ST,4B	60	33
Tallin	4,300	440	ST,4B	80	38
<u>Frigate</u>					
Mirka I, II	1,100	270	2GT+2D	37	33
Petya I	1,150	270	GT+D	30	30
Petya II	1,150	270	GT+D	6	30
Riga	1,600	299	ST,2B	25	28
Kola	1,900	315	ST,2B	30	30

TABLE A- 2 (Cont'd)

<u>Type & Class</u>	<u>Full Load Displ (l.t.)</u>	<u>Length Overall (ft.)</u>	<u>Prime Mover</u>	<u>Inst. Power (1000 shp)</u>	<u>Speed (Knots)</u>
<u>Corvette</u>					
Grisha I, II	750	235	2GT+2D		30
Poti	650	195	2GT+2D	20	28
Kronstadt	380	171	3D	3	24
SO I	250	139	3D	6	29
Nanuchka	800	197	D		32
Others					
<u>Light Forces</u>					
Osa I, II	200	129	3D	13	32
Stenka	210	131	3D	16	40
Shershen (Hyd)	160	116	3D	13	41
Peshla (Hyd)	46	96	D	12	35
Turya (Hyd)	190	123	3D	13	45
<u>ACV & SES</u>					
Aist	220	145	6GT		70
Ekranoplan		400	10GT		300
Gus (skate)	27	68	3GT	2	58
<u>Survey & Track</u>					
Polyus	6,900	366	DE	3	14
Gagarin	45,000	758	2ST	19	17
Komarov	17,500	511	D	24	22
<u>Ice Breakers</u>					
Nuc. I	16,000	440	4ST,3N	44	18
Nuc. II	25,000	459	ST,2N	30	25
Moskva	15,360	369	8DE	22	18
Ermak	20,241	443	9DE	36	18

TABLE C-1
GEARBOX WEIGHT ESTIMATING EQUATIONS

Type	Code	Number Branches (b)	Stage Reduction Ratio (max)	Weight Equation
Offset	1101	1	8	$W = 22500 (Q'/K_1)^{0.82}$
	1101R	1	8	$W = 36000 (Q'/K_1)^{0.82}$
Epicyclic	1101	3	12	$W = 47000 (Q'/K_1)^{0.82}$
		4	6	
		5	4.2	
		6	3.5	
Epicyclic & Reverse	1101R	3	12	$W = 70500 (Q'/K_1)^{0.82}$
		4	6	
		5	4.2	
		6	3.5	
Epicyclic, 2 Stage	1102	S.A. Above	S.A. Above	$W = 63000 (Q'/K_1)^{0.82}$
		S.A. Above	S.A. Above	$W = 63000 (Q'/K_1)^{0.82} [1+1/2(m)^{0.82}]$
Offset, 2 Stage	1102	2	80	$W = 36000 (Q'/K_1)^{0.82}$
		2	80	$W = 36000 (Q'/K_1)^{0.82} + 22500 (Q'/K_1)^{0.82}$
Bevel	1101	1, 2	3	$W = 36000 (Q'/K_1)^{0.82}$

TABLE C-1 (Cont'd)

GEARBOX WEIGHT ESTIMATING EQUATIONS

Type	Code	Number Branches (b)	Stage Reduction Ratio (max)	Weight Equation
Offset, Multi Out	1201	2	8	$W = 36000 (Q'/K_1)^{0.82}$
Offset, Multi Out & Rev.	1201R	2	8	$W = 36000 (Q'/K_1)^{0.82} + 22500 (Q'/K_{1m})^{0.82}$
Offset, Multi Out, 2 Stage	1202	4	30	$W = 100,000 (Q'/K_1)^{0.64}$, @ $(Q'/K_1) \leq 6$
				$W = 112,000 (Q'/K_1)^{0.57}$, @ $(Q'/K_1) > 6$
Offset, Multi Out, 2 Stage & Rev.	2102	4	30	$W = 100,000 (Q'/K_1)^{0.64} + 45000 (Q'/K_{1m})^{0.82}$, @ $Q'/K_1 \leq 6$
				$W = 112,000 (Q'/K_1)^{0.57} + 45,000 (Q'/K_{1m})^{0.82}$, @ $Q'/K_1 > 6$
Offset, Multi In, 2 Stage	2102	4	80	$W = 60,000 (Q'/K_1)^{0.69}$, @ $(Q'/K_1) \leq 6$
				$W = 85,000 (Q'/K_1)^{0.50}$, @ $(Q'/K_1) > 6$
Offset, Multi In, 2 Stage & Rev.	2102R	4	80	$W = 60,000 (Q'/K_1)^{0.69} + 45000 (Q'/K_{1m})^{0.82}$, @ $(Q'/K_1) \leq 6$
				$W = 85,000 (Q'/K_1)^{0.50} + 45000 (Q'/K_{1m})^{0.82}$, @ $(Q'/K_1) > 6$

TABLE D-1
 SURVEY OF EXISTING SHAFTING INSTALLATIONS

Ship	Displacement Tons	Bulkhead Spacing ft	No. Shafts	Shaft Dia., In.		Total Length ft	Total Weight lb/ft	Max. Shp/Shaft	Max. rpm
				Inboard OD/ID	Outboard OD/ID				
CVA-63	80,000	20-50	4	26/16	28/15	1,342	1,256	70,000	170
CVAN-68	91,400	40-70	4	23/16	28/17	1,308	1,062	75,000	170
DLGN-38	10,000	20-30	2	16/11	20/14	444	522	45,000	250
DD-963	7,800	20-44	2	19/13	22/14	454	781	40,000	190
DD-931	4,000	16-36	2	13.5/9	14.5/10	304	1,355	35,000	350
DD-445	3,000	30-35	2	N.A.	16/11	266	388	30,000	350
DE-1052	4,100	10-35	1	19/10	24/10	130	1,027	35,000	300
AOE-1	52,500	60-90	2	26/17	26/17	306	1,299	50,000	150
AOE-3	52,500	60-90	2	26/17	26/17	307	1,290	50,000	150

SURVEY OF INSTALLED POWER FOR SELECTED SHIP TYPES

- + HVY CARRIERS
- △ LT CARRIERS
- HVY CRUISERS
- ◇ HVY DESTROYER
- △ SURF. EFF. SHIP
- X HYDROFOIL
- * PREDICTED
- ▽ AUXILIARY SHIP
- ◇ COAST GUARD
- USSR
- UNTD. KINGDOM
- SWEDEN
- △ TAIWAN

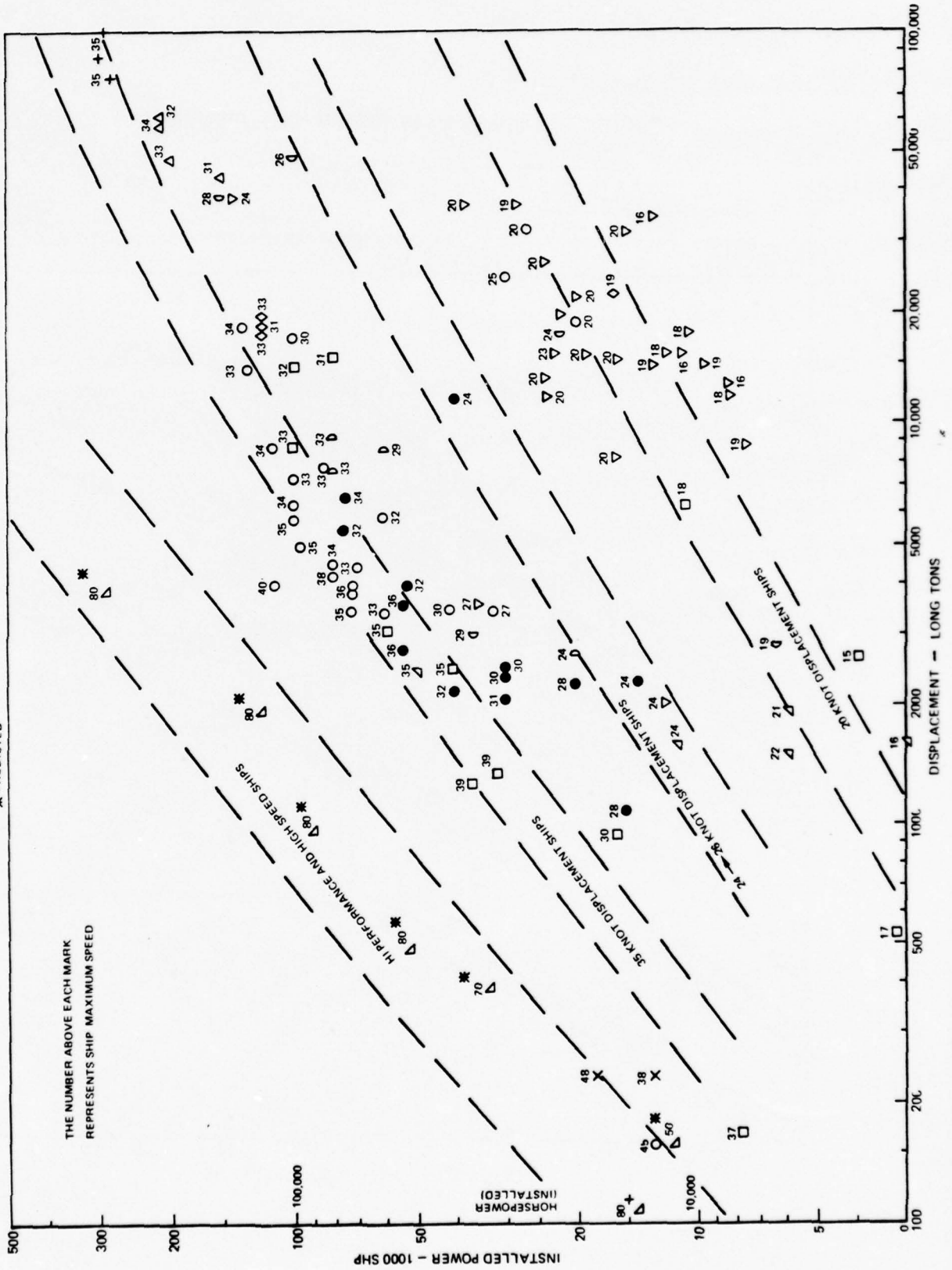

CORRECTED CLEAN HULL POWER REQUIREMENTS

— SURVEY RESULTS

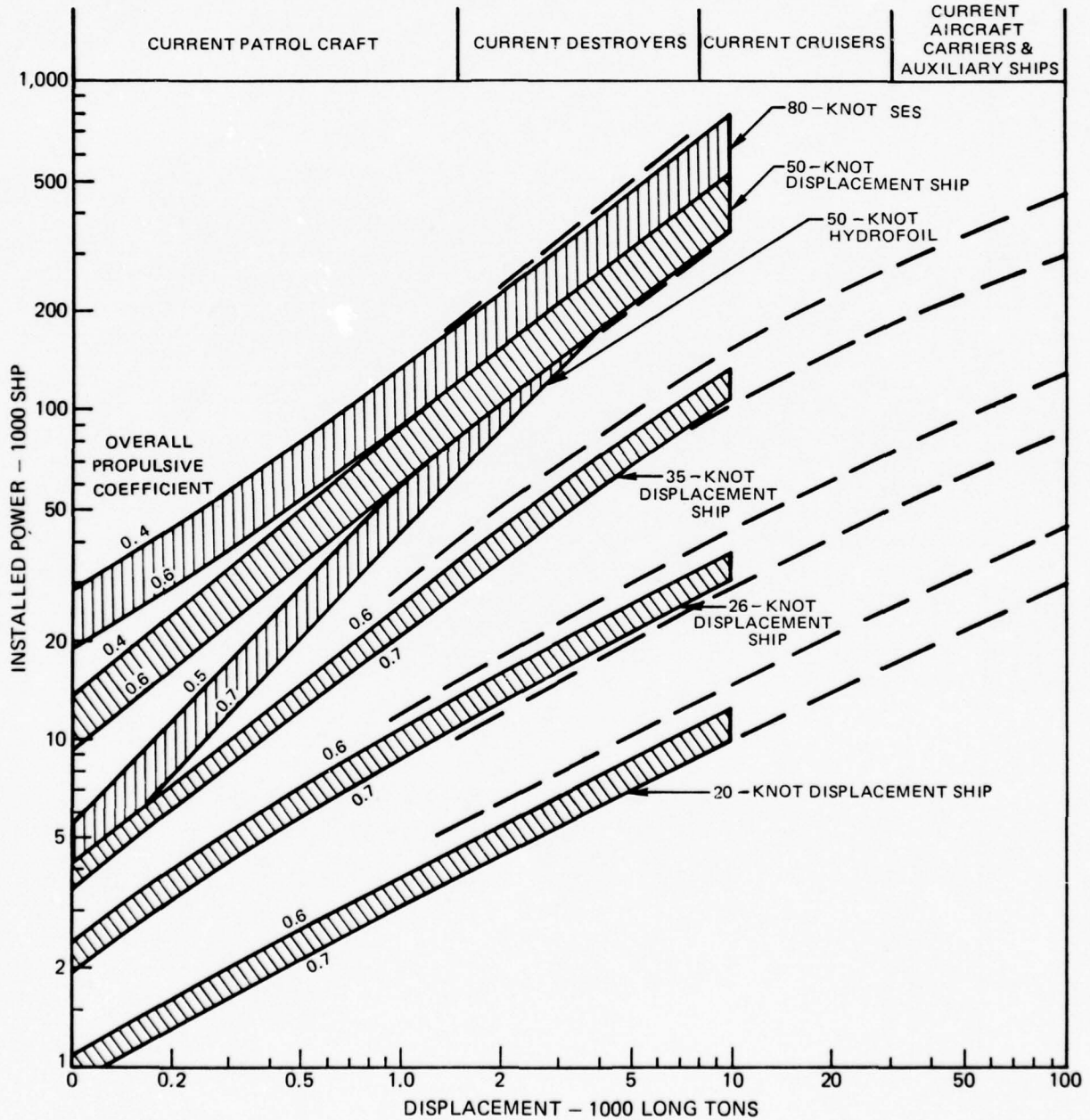

TYPICAL SES LIFT POWER REQUIRED AT 80 KNOTS

○ = FROM CONSULTANT

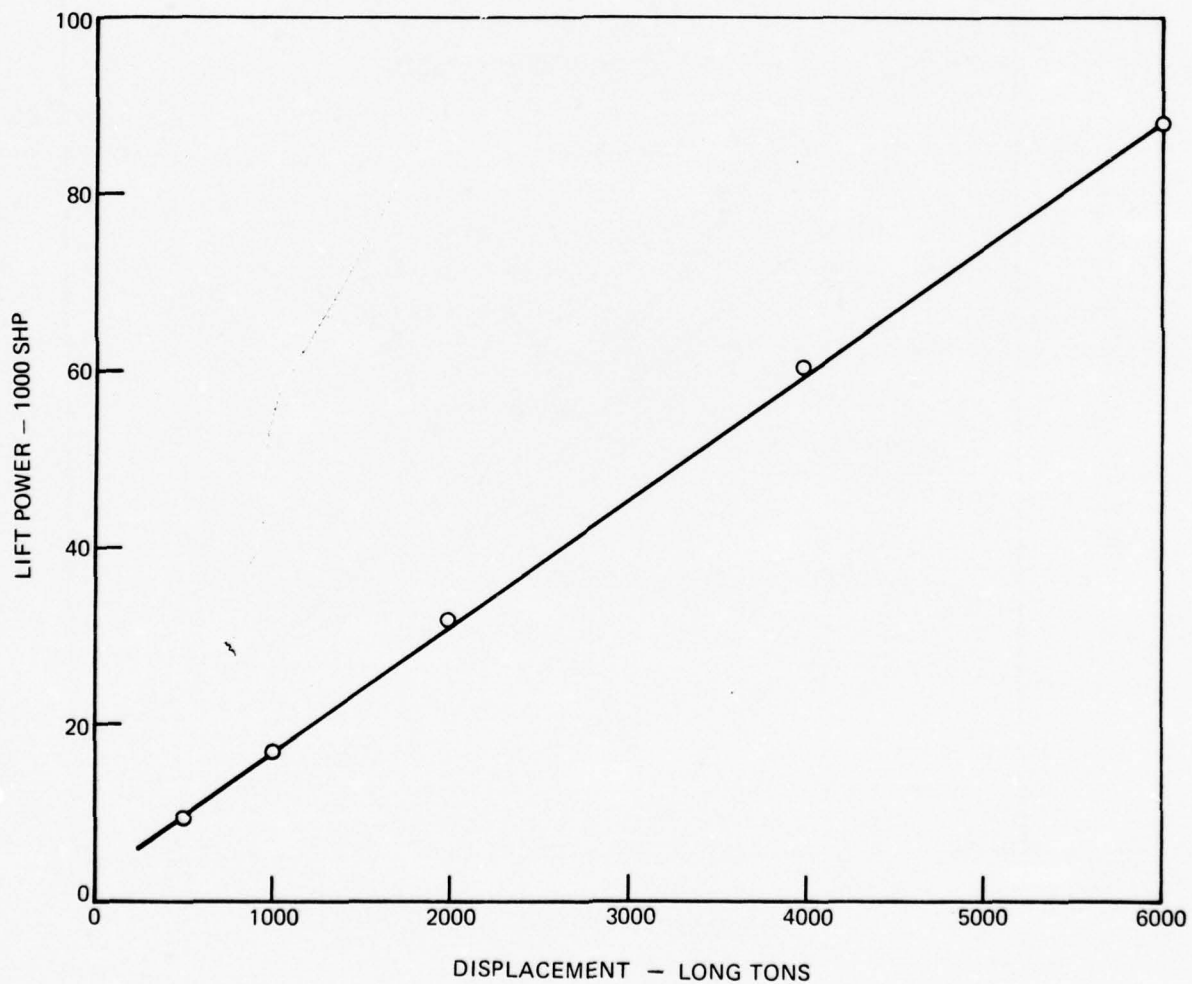

RELATIONSHIP OF SUBCAVITATING EFFICIENCY TO ROTATIVE COEFFICIENT

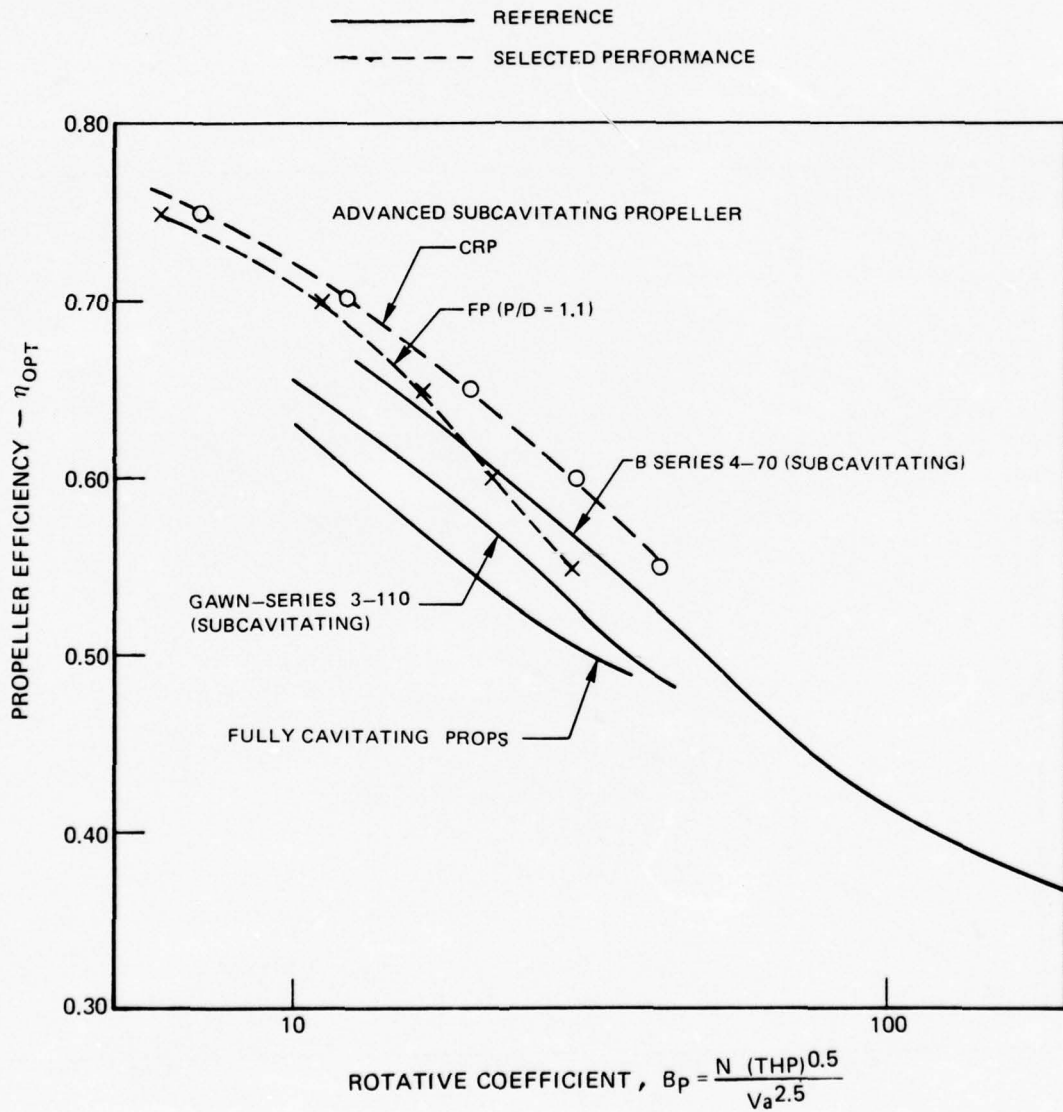

SUBCAVITATING PROPELLER DESIGN PARAMETERS

P/D= PITCH/DIAMETER RATIO

- FIXED PITCH, P/D = 1.1
- - - CRP (OPTIMUM DIAMETER)

$$J = V_a / ND, \quad B_p = (N)(THP)^{0.5} / (V_a)^{2.5}$$

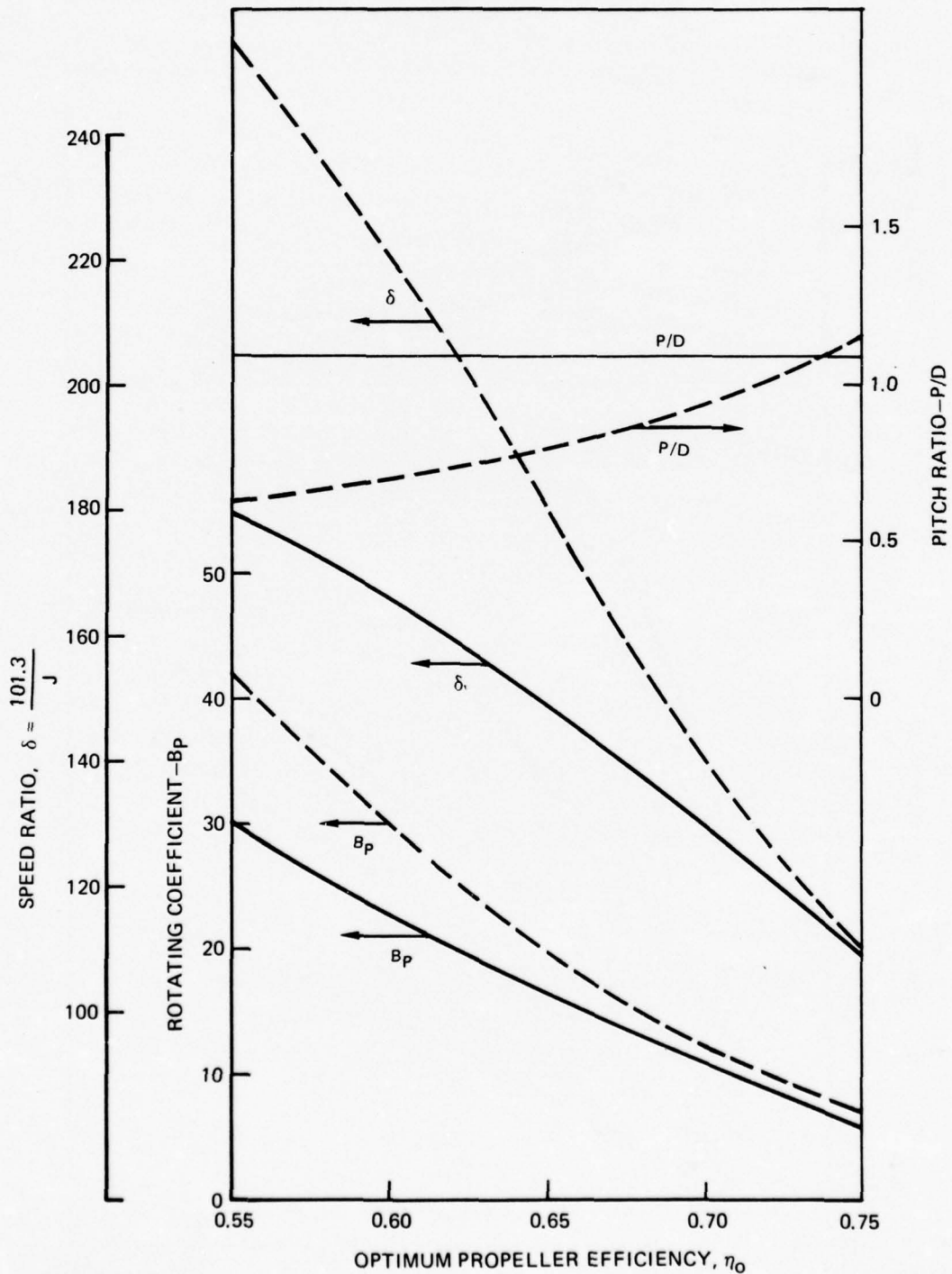

SUBCAVITATING PROPELLER DESIGN CHART FOR 26-KNOT AUXILIARY SHIPS

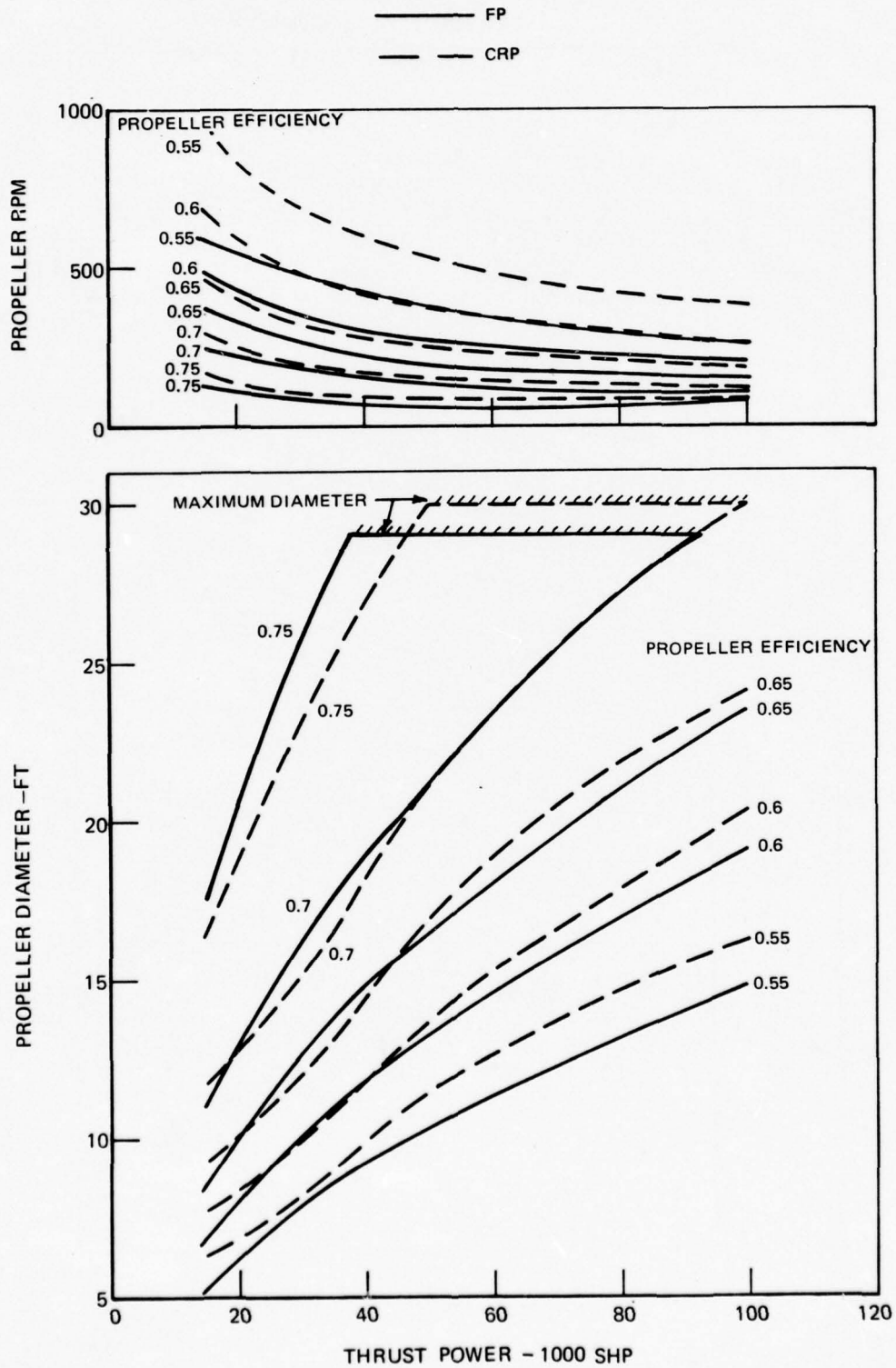

SUBCAVITATING PROPELLER DESIGN CHART FOR 35-KNOT SHIPS

— FP
- - - CRP

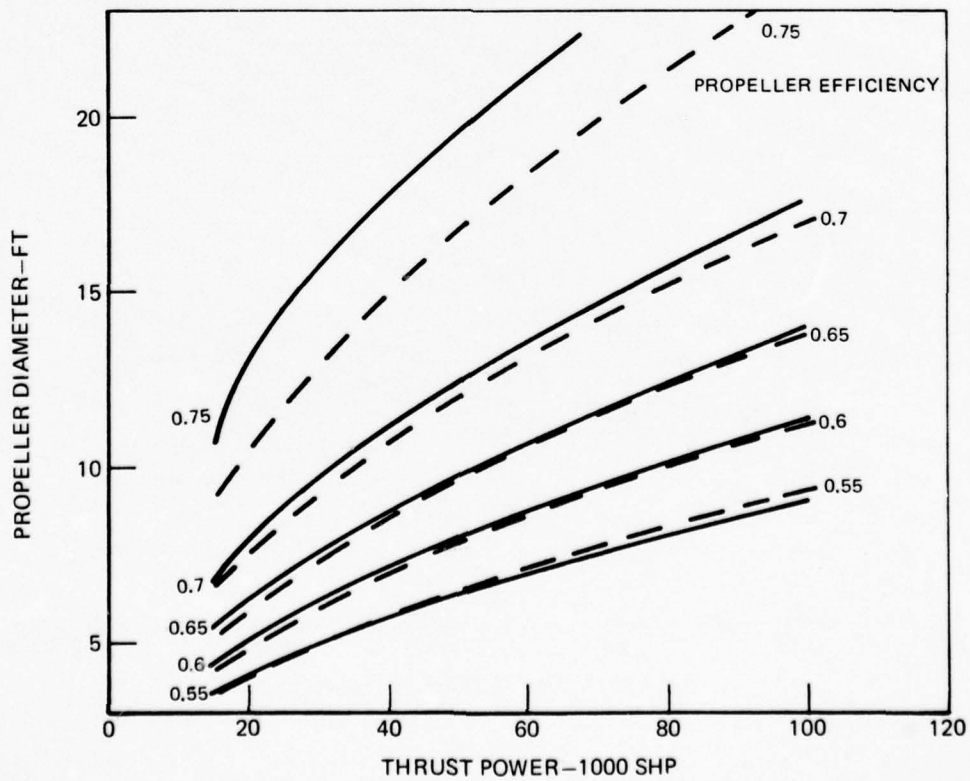
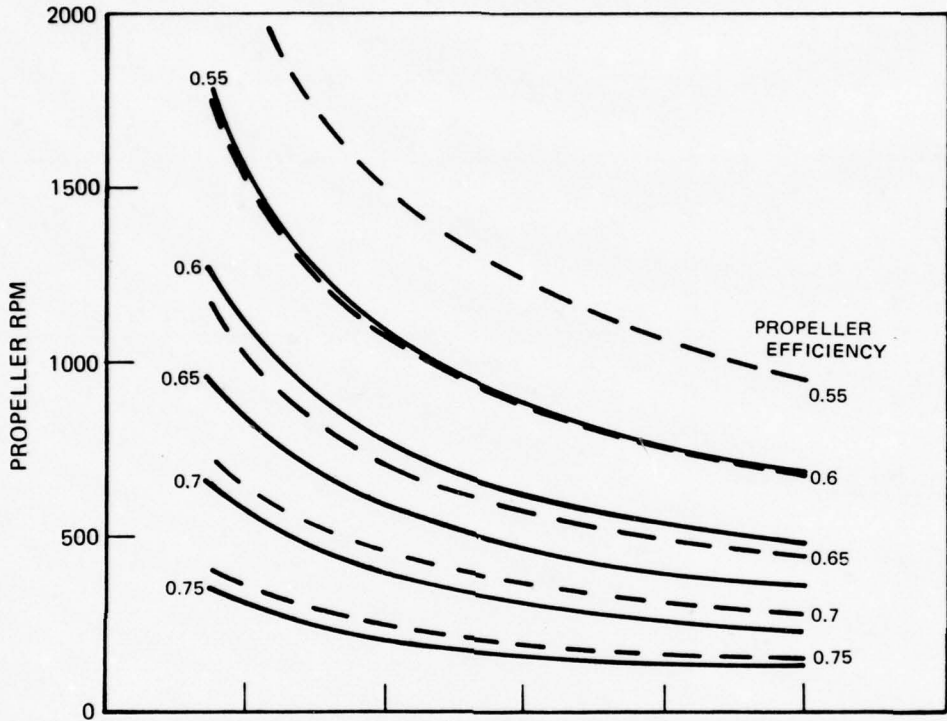

SUPERCAVITATING PROPELLER DESIGN PARAMETERS

P/D= PITCH/DIAMETER RATIO

- FIXED PITCH, P/D = 1.0
- - - CRP, MAX EFFICIENCY FOR GIVEN C_T

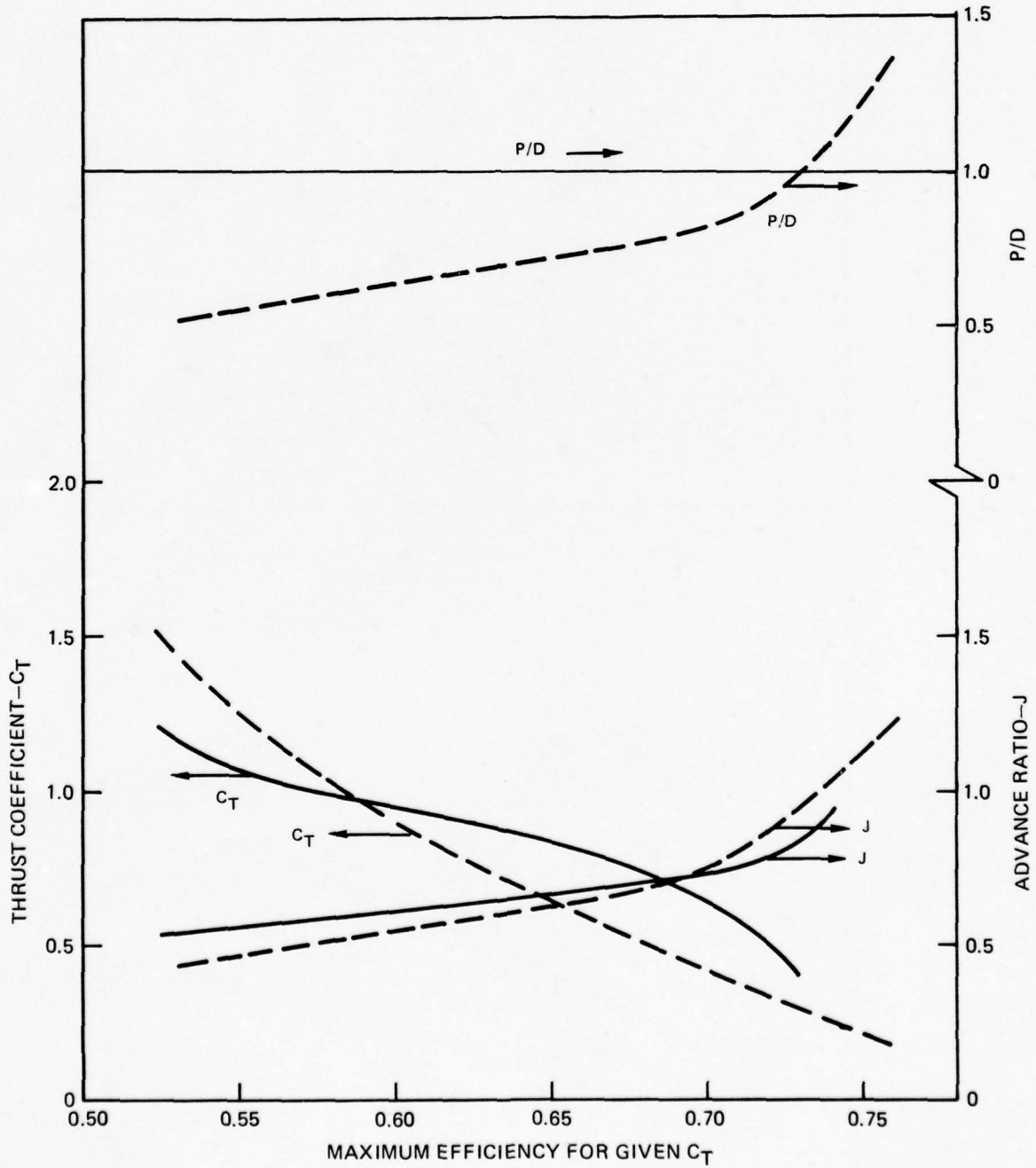

SUPERCAVITATING PROPELLER DESIGN CHARTS FOR 50-KNOT SHIPS

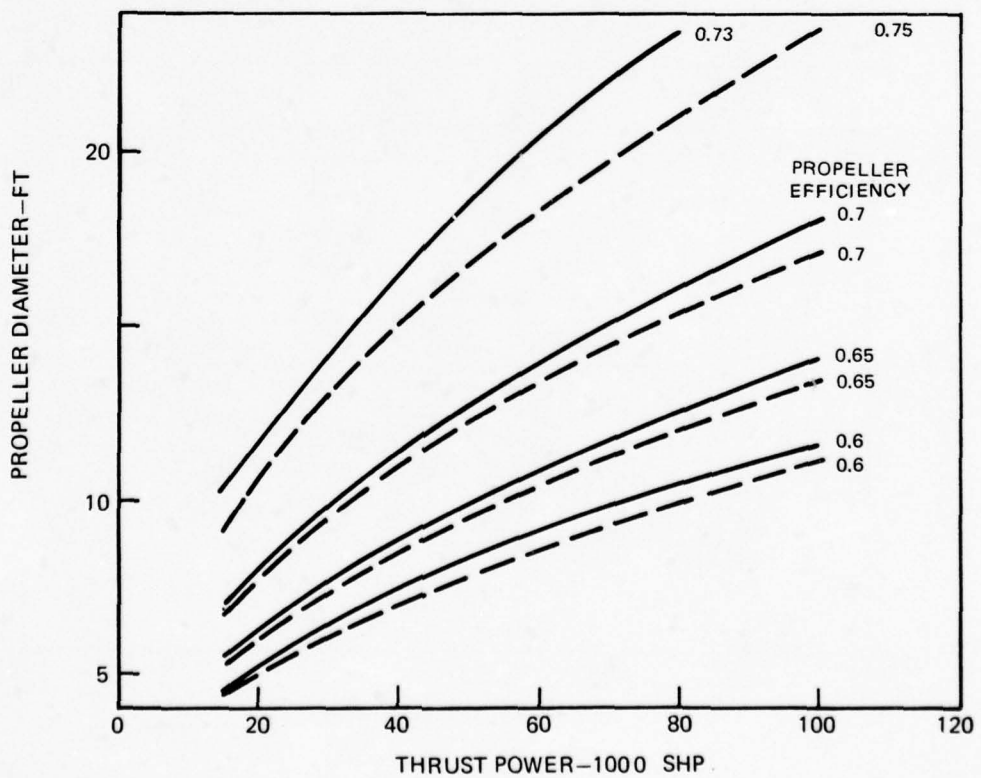
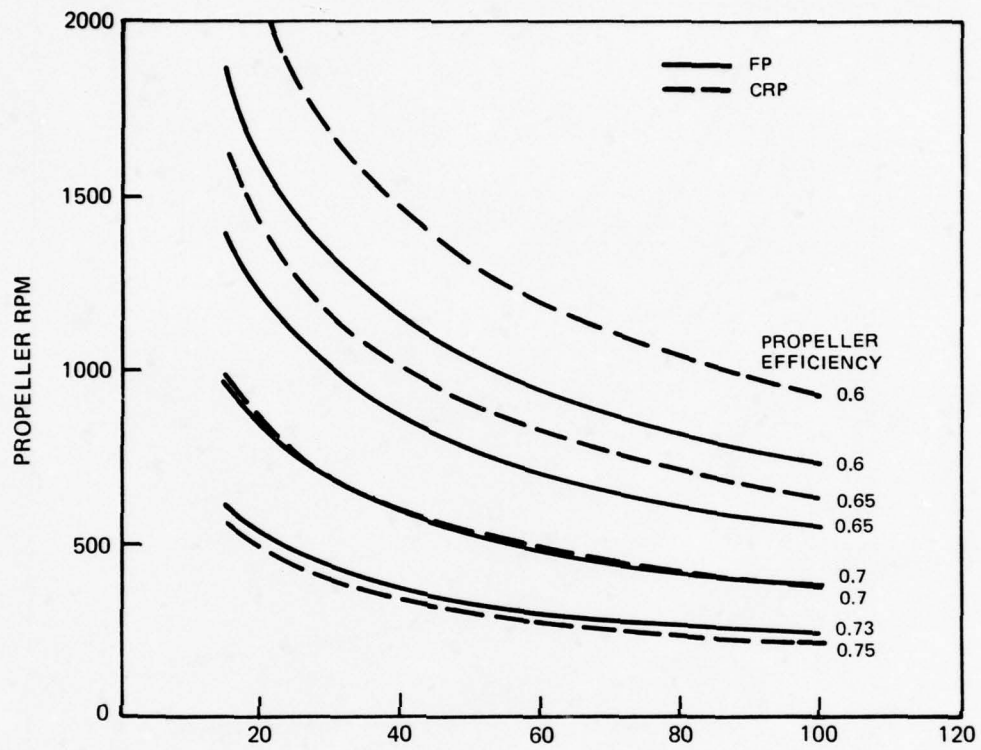

SUPERCAVITATING PROPELLER DESIGN CHARTS FOR 80-KNOT SHIPS

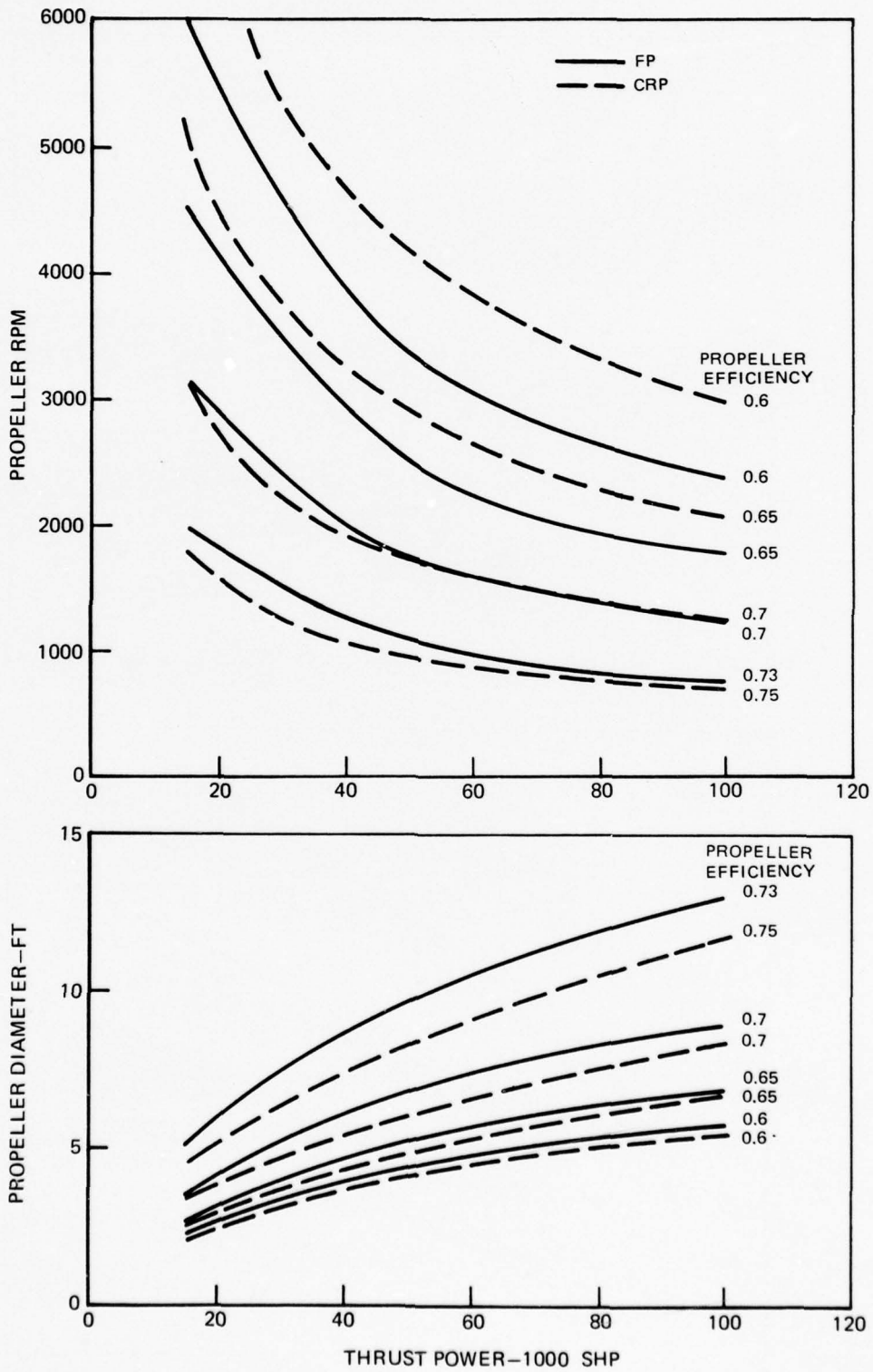

OPERATING REGIONS FOR SUB- AND SUPERCAVITATING PROPELLERS

LEGEND

- 27 KNOT AUXILIARY SHIPS
- 35 KNOT DESTROYERS/CRUISERS/CARRIERS
- △ 50 KNOT DESTROYERS
- ◇ 80 KNOT HIGH PERFORMANCE SHIP

OPEN SYMBOLS = CRP

FILLED SYMBOLS = FP

η_0 = PROPELLER EFFICIENCY

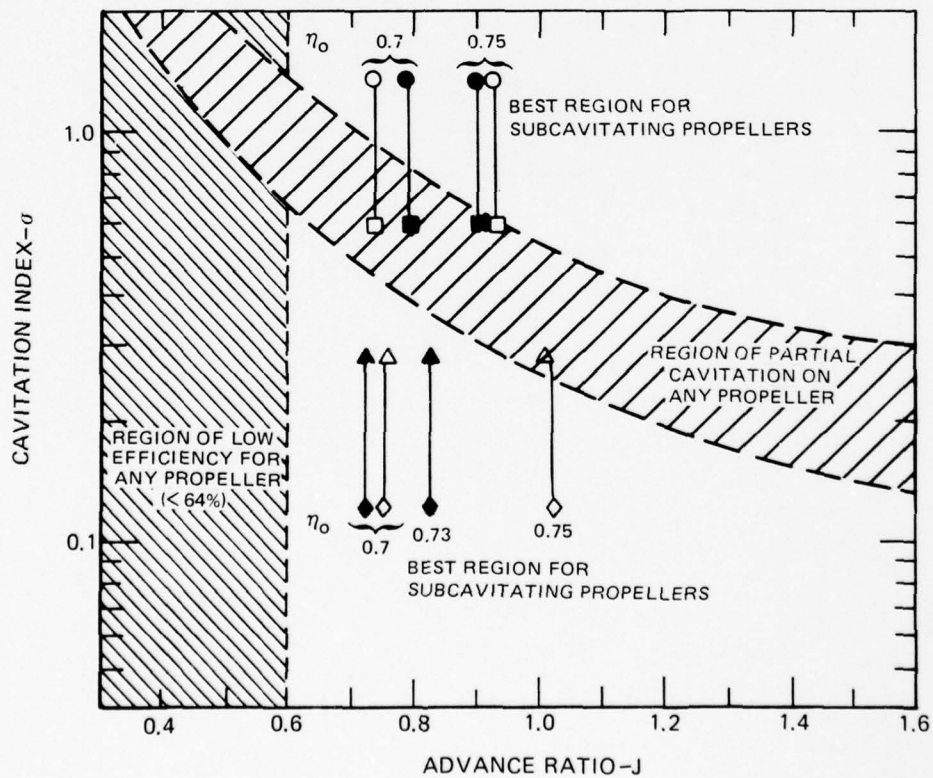

THRUST COEFFICIENT VARIATION WITH SPEED

$$C_T \text{ PROPORTIONAL TO } \frac{T_{HP}}{(V)^3}$$

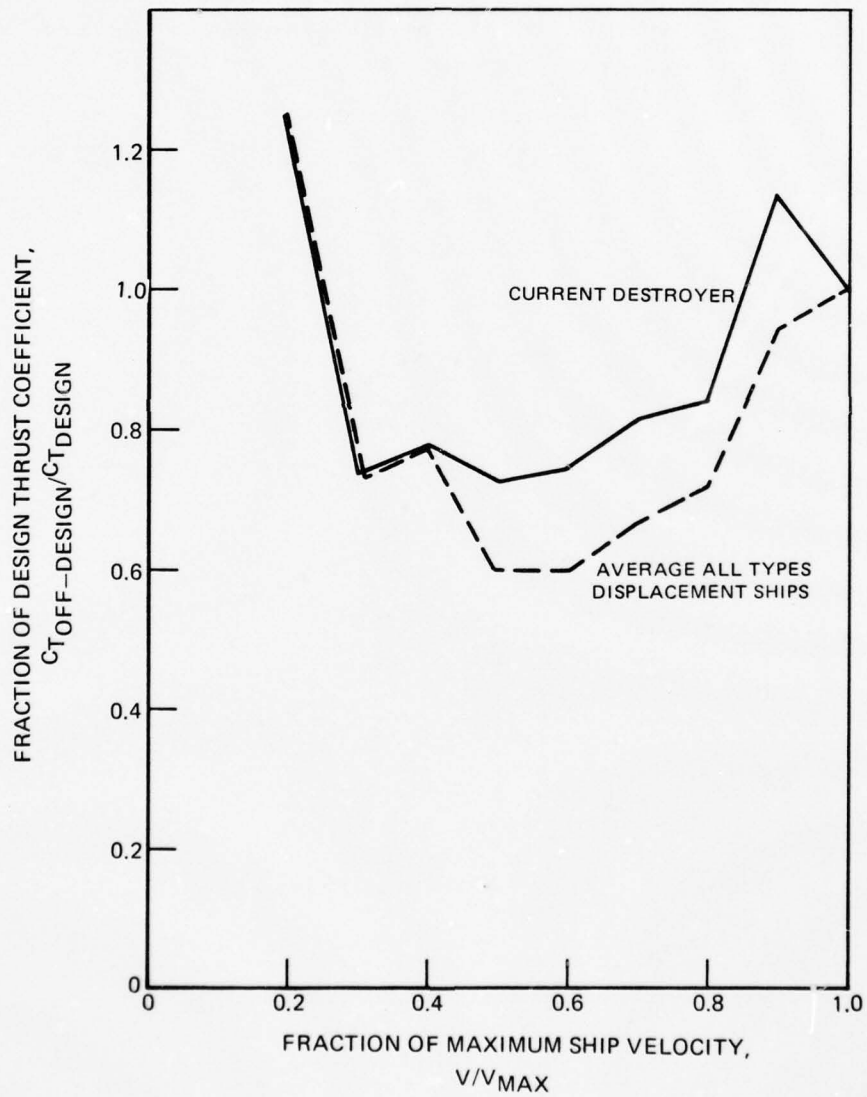

CRP PROPELLER OFF-DESIGN PERFORMANCE

FILLED SYMBOLS = SUBCAVITATING
 OPEN SYMBOLS = SUPERCAVITATING

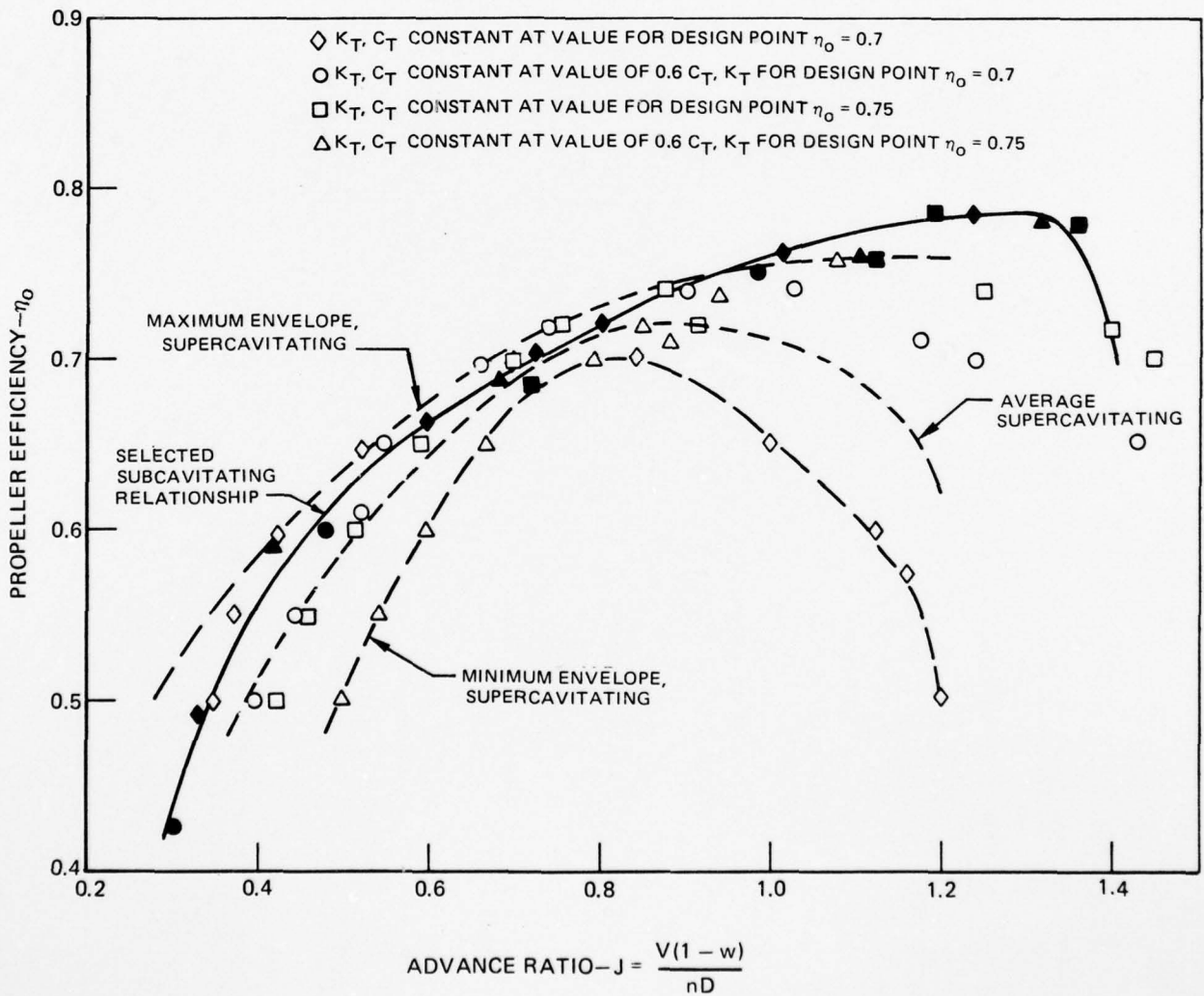

GEARBOX TYPES AND CONFIGURATIONS CONSIDERED

b = NUMBER OF PATHS TRANSMITTING POWER

CODE = x x x x

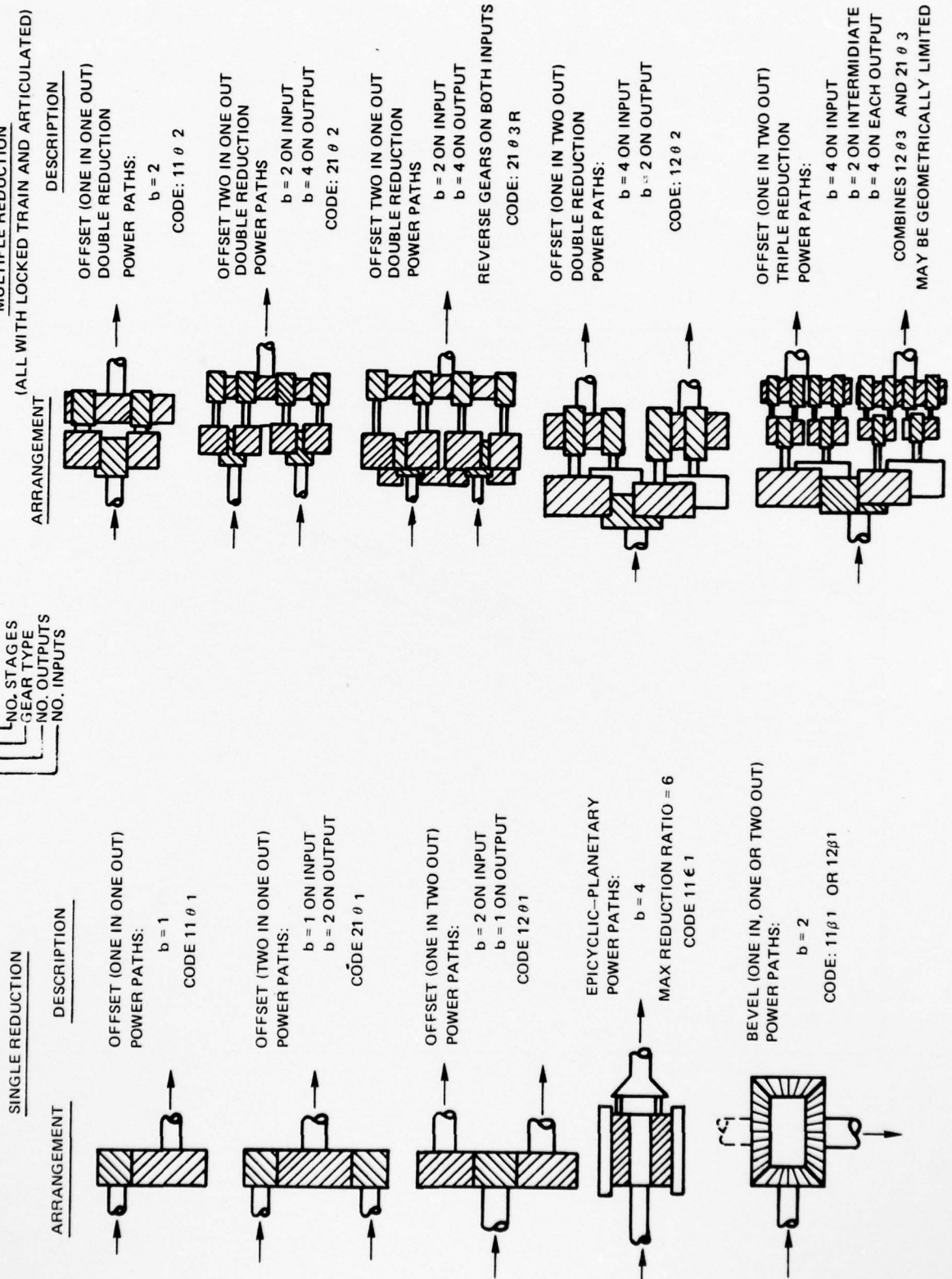
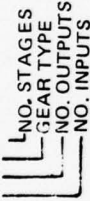

SURVEY OF EXISTING GEARBOX WEIGHT CHARACTERISTICS

- DOUBLE REDUCTION, ONE INPUT
- △ DOUBLE REDUCTION, TWO INPUTS
- ▽ TRIPLE REDUCTION, TWO INPUTS
- ◇ SINGLE REDUCTION, ONE INPUT
- ◻ SINGLE REDUCTION, TWO INPUTS
- EPICYCLIC-PLANETARY
- ☆ EPICYCLIC-STAR

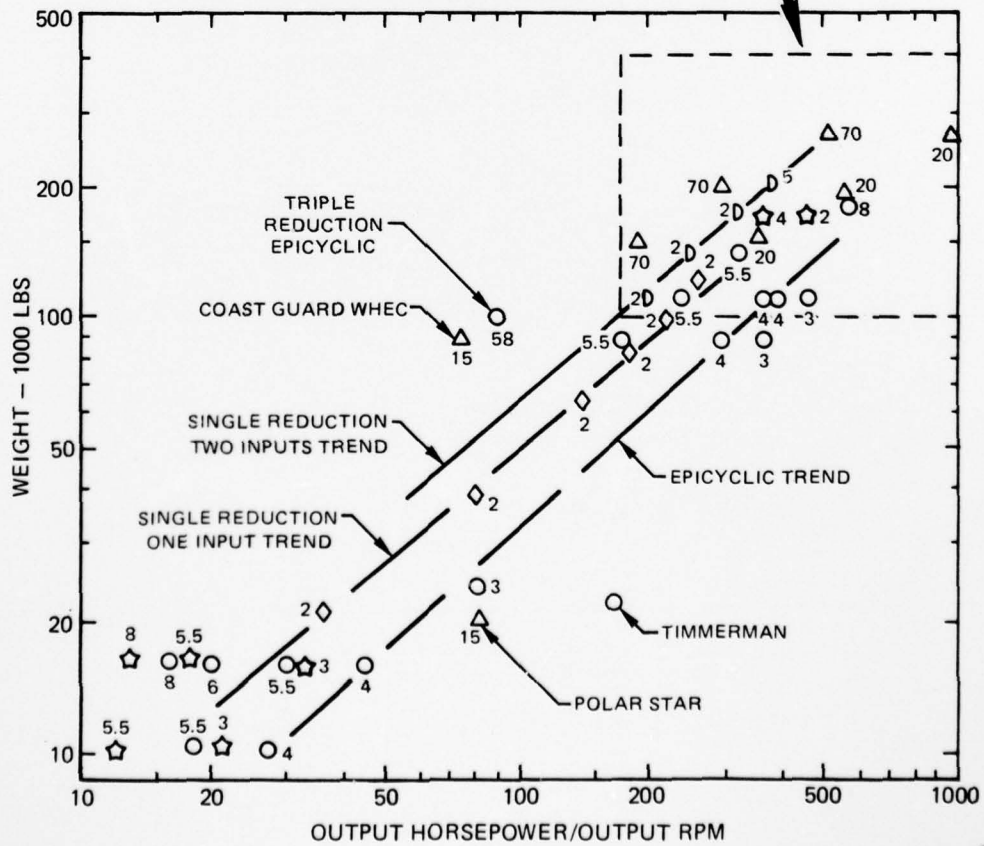
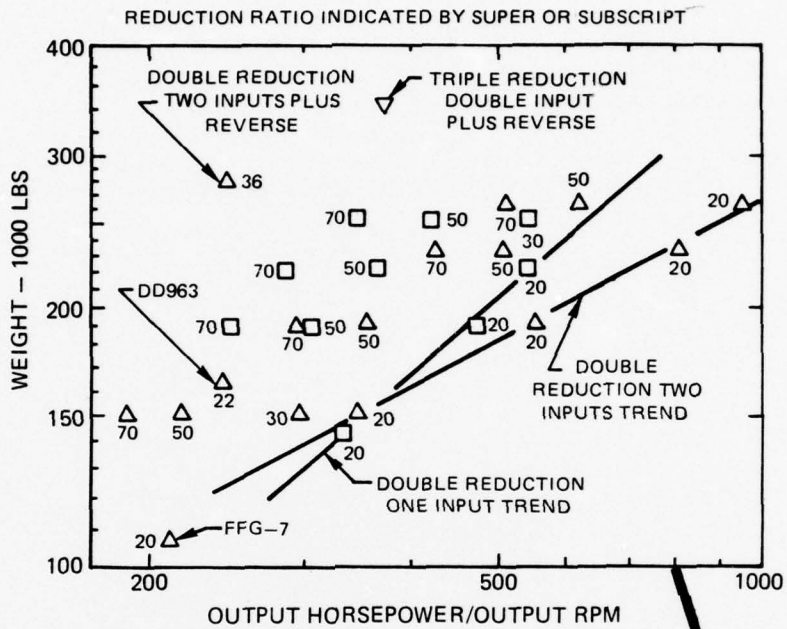

RELATIONSHIP OF WEIGHT TO POWER/SPEED-FACTOR FOR SINGLE REDUCTION GEARBOXES

- ◇ SINGLE REDUCTION, ONE INPUT
- ◻ SINGLE REDUCTION, TWO INPUTS
- △ BEVEL GEARS
- EPICYCLIC-PLANETARY
- ☆ EPICYCLIC-STAR

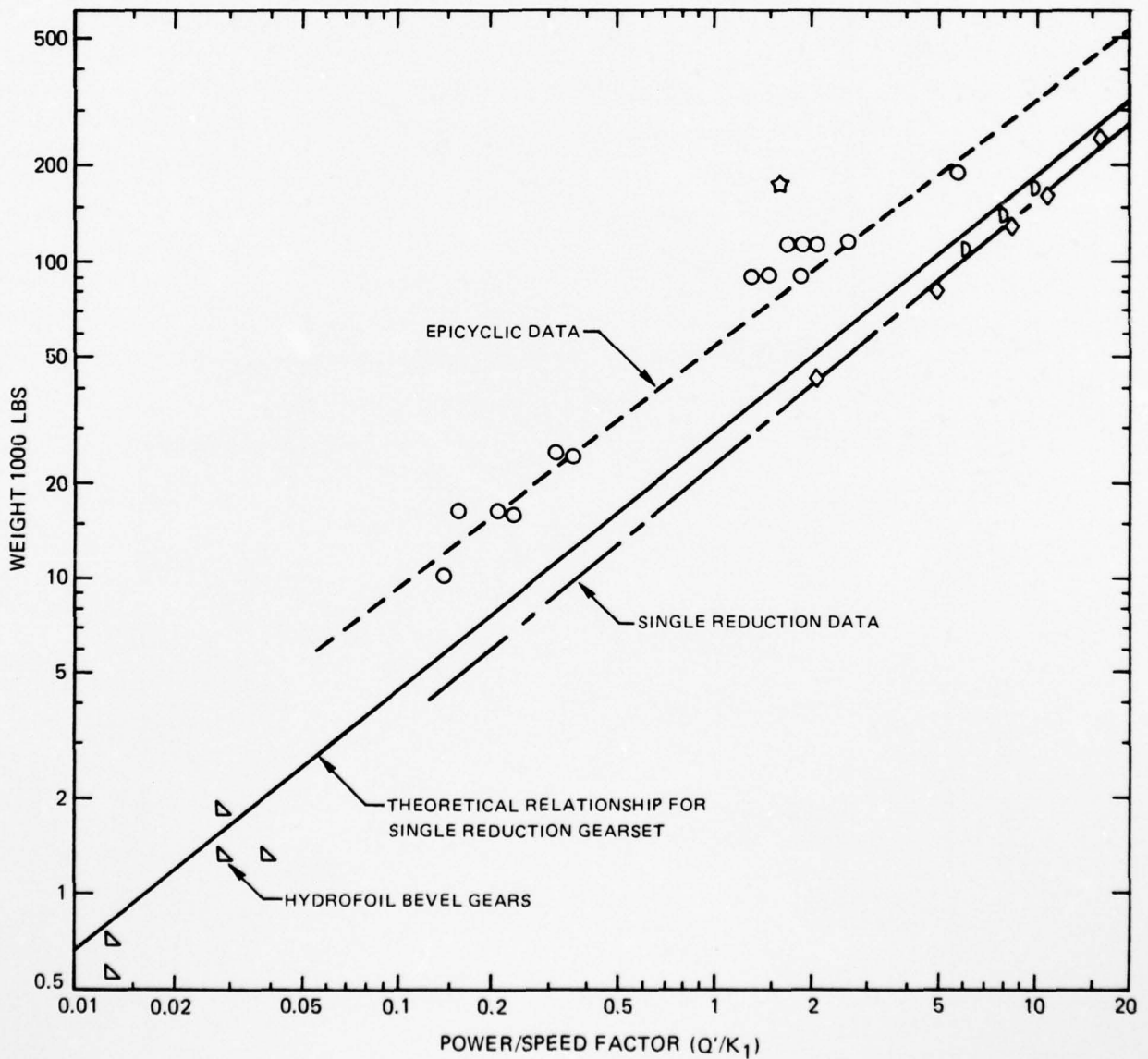

RELATIONSHIP OF WEIGHT TO POWER/SPEED-FACTOR FOR MULTIPLE REDUCTION GEARBOXES

CODE FOR ACTUAL DATA

SOLID SYMBOLS ARE CURRENT NAVAL SHIPS

- DOUBLE REDUCTION, ONE INPUT
- △ DOUBLE REDUCTION, TWO INPUTS
- ◤ DOUBLE REDUCTION, TWO INPUTS PLUS REVERSE
- ▽ TRIPLE REDUCTION, TWO INPUTS PLUS REVERSE
- TWO EPICYCLICS IN SERIES

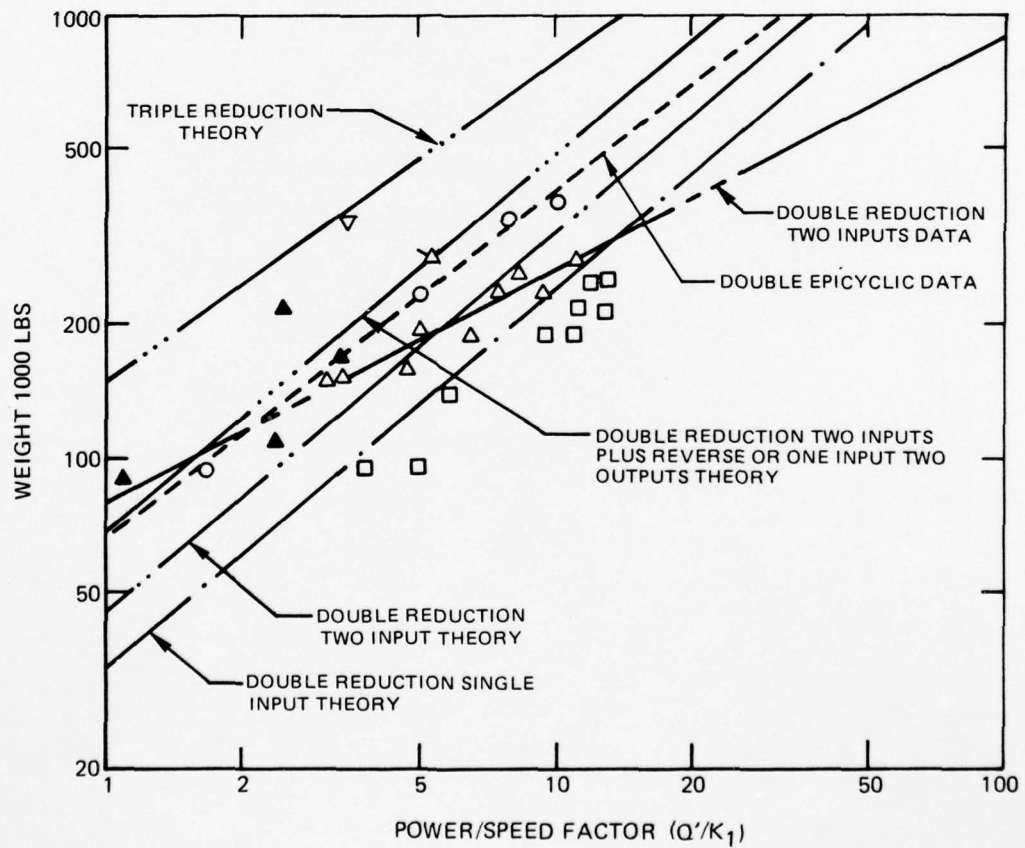

THEORETICAL MAXIMUM HORSEPOWER TRANSMITTED PER GEAR TOOTH

m = SINGLE STAGE REDUCTION RATIO
 K = COMPRESSIVE LOAD FACTOR LB/IN./IN.

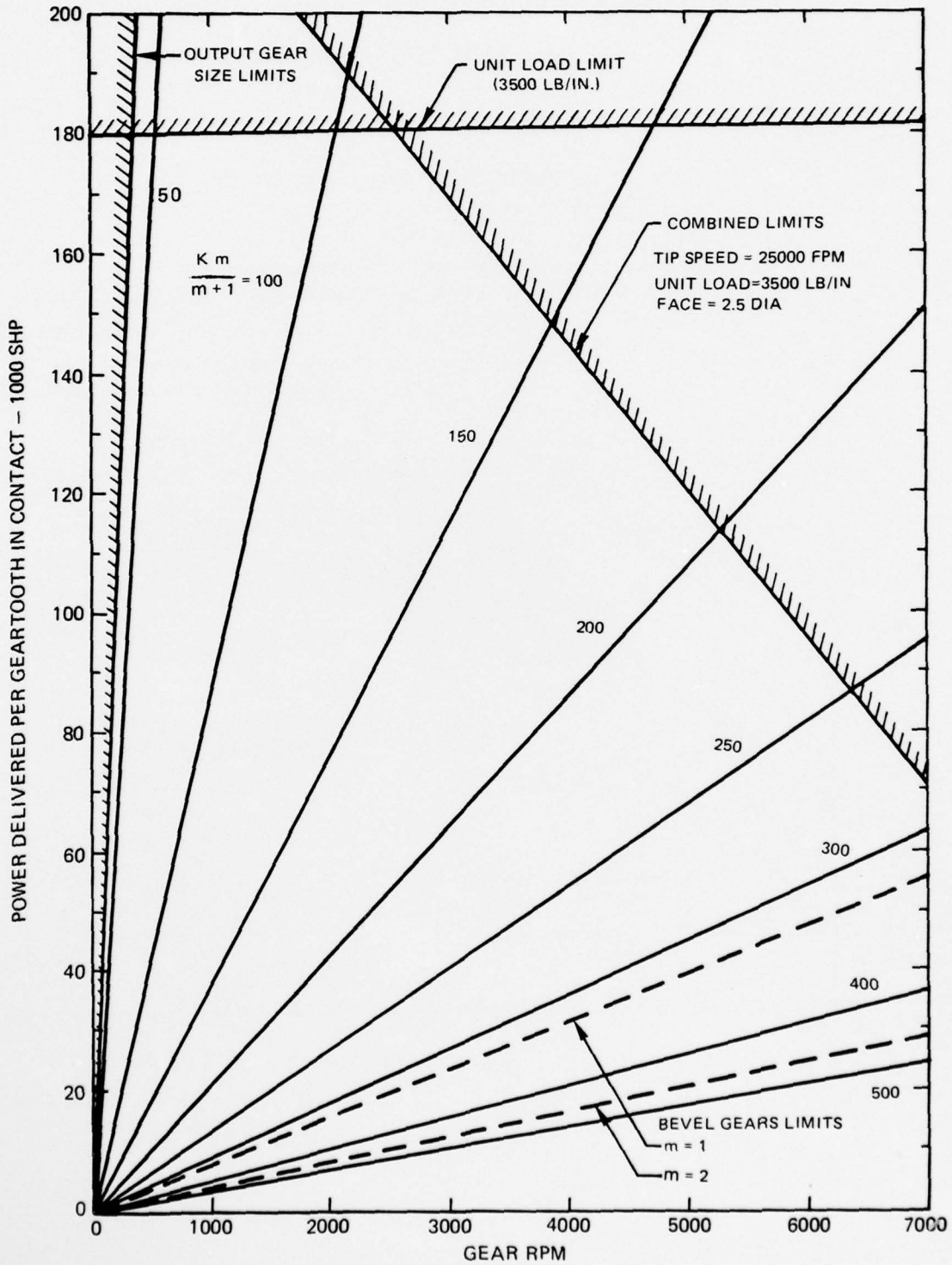

SURVEY OF PROPULSION SYSTEM LAYOUTS

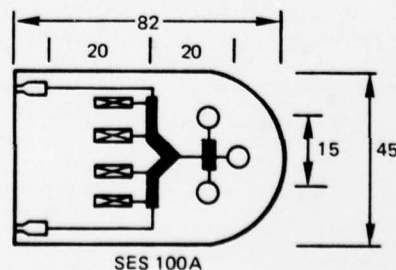
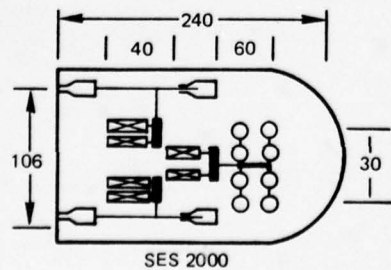
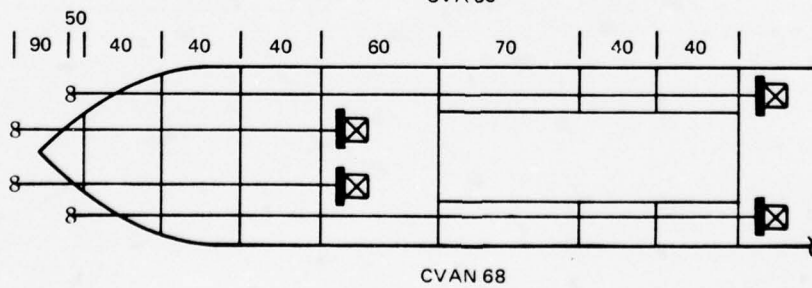
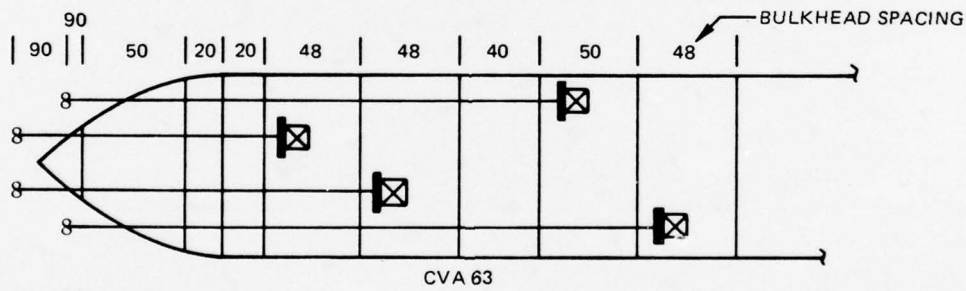
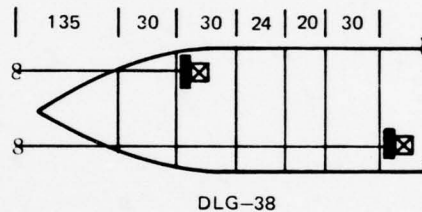
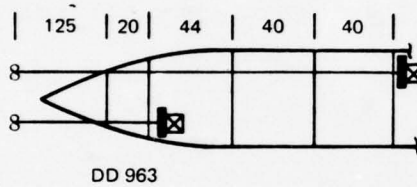
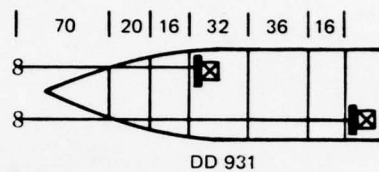
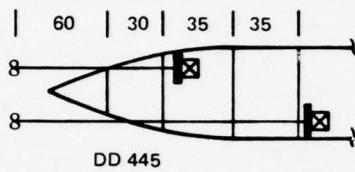
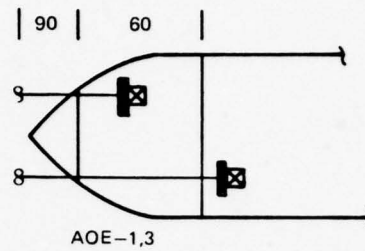
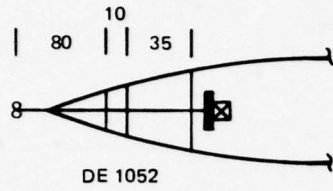
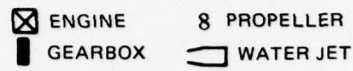

TYPICAL PROPULSION SYSTEM LAYOUTS SELECTED

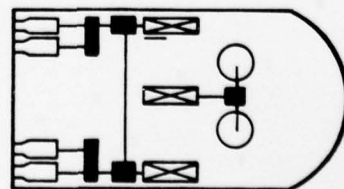
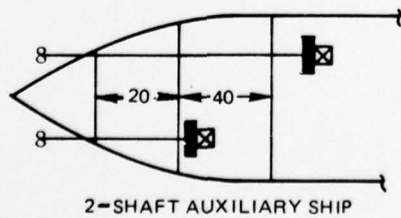
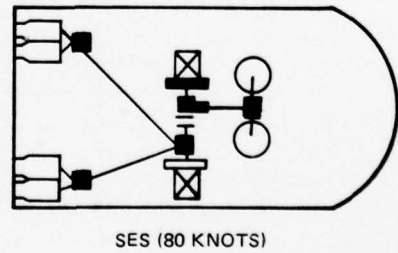
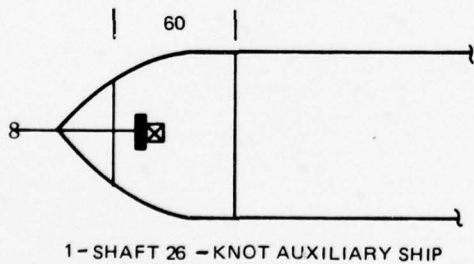
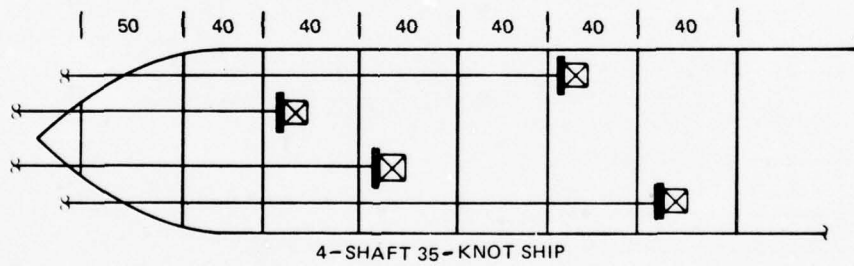
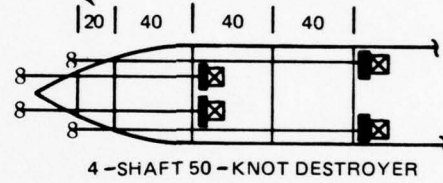
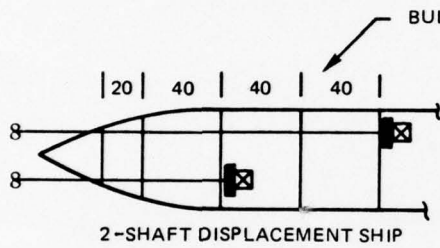
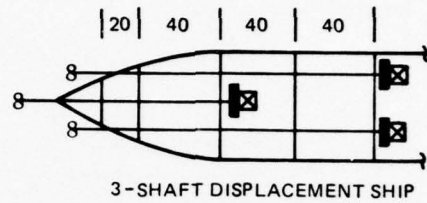
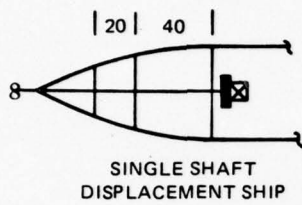
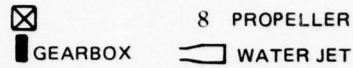

TOTAL SHAFT LENGTH MODELS

35-KNOT SHIPS EXCEPT AS MARKED

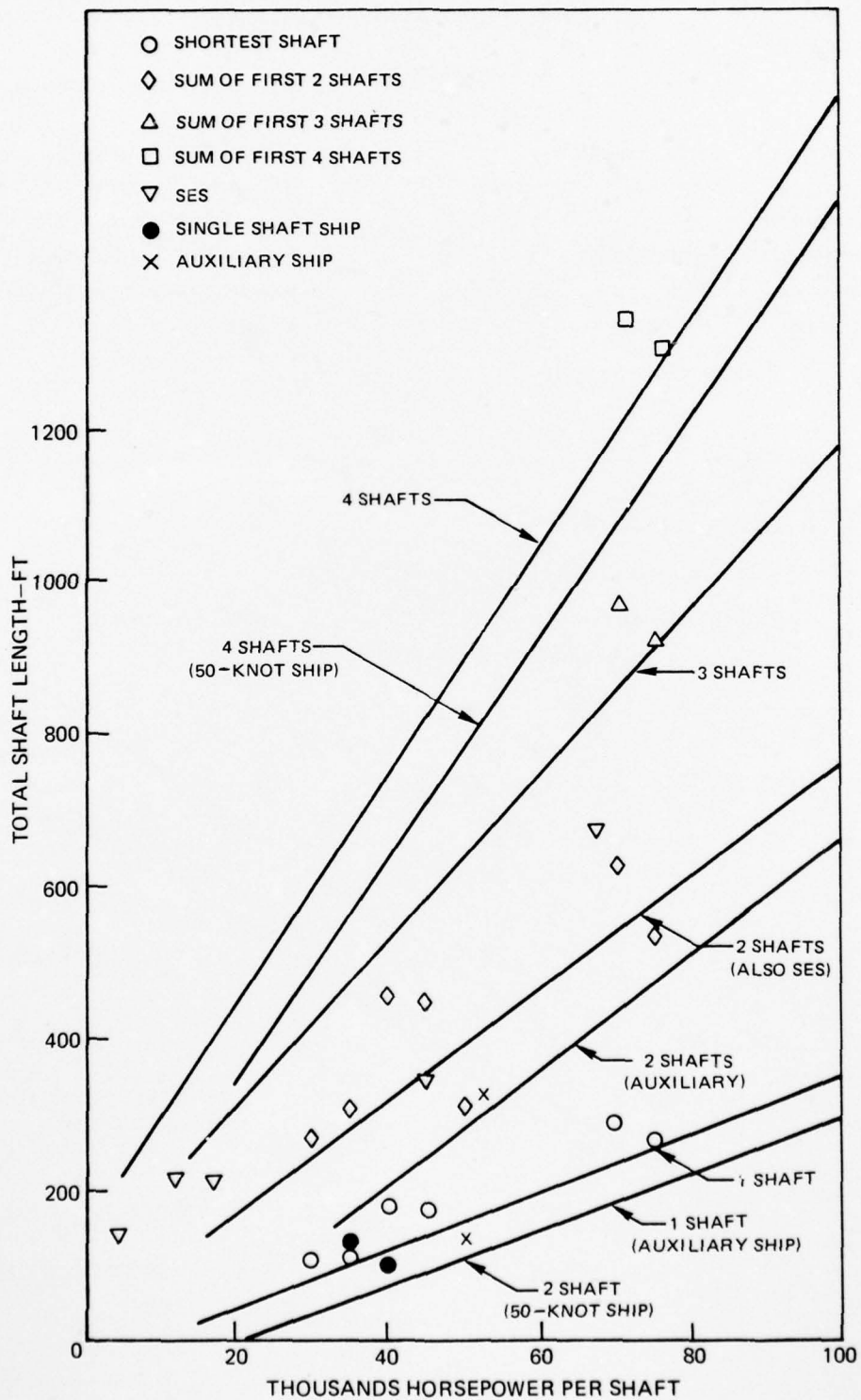

SHAFT WEIGHT PER UNIT LENGTH

z=0.65 UNLESS NOTED

f_s = DENSITY OF STEEL=0.28 LB/IN³

T=TORQUE

S_s =SHEAR STRESS

z=RATIO OF INNER/OUTER DIA.

W=WEIGHT

L=LENGTH

○ OUTBOARD SHAFTING

□ INBOARD SHAFTING

△ AVERAGE SHAFT WIEGHT

▲ C.R.P. AVG. SHAFT WEIGHT

× AUXILIARY SHIP, AVG. WEIGHT

* z=0.69

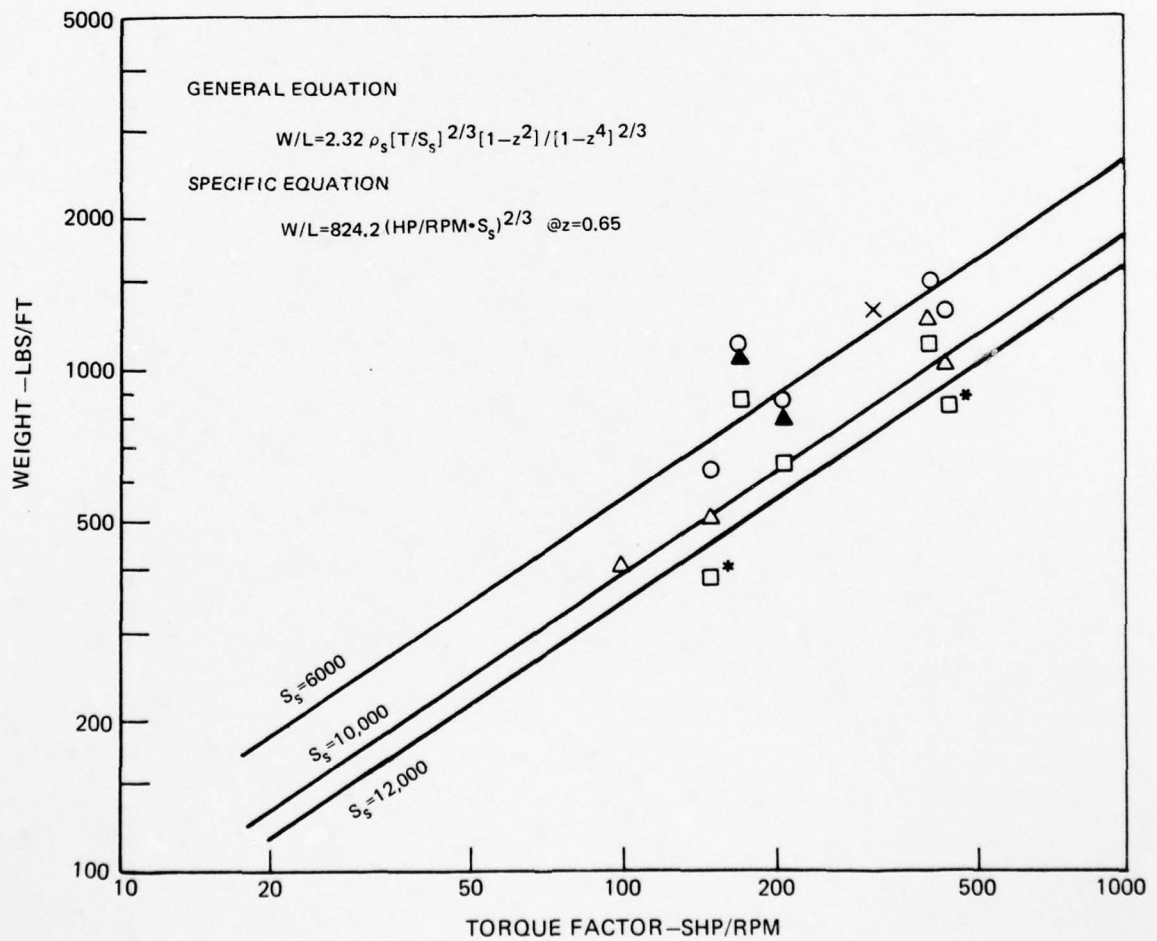

DISTRIBUTION LISTS

LCDR W. R. Seng (3)
Scientific Officer
Office of Naval Research
Code 473
800 N. Quincy Street
Arlington, VA 22217

Commander, Defense Contract Admin. (1)
Services District, Hartford
96 Murphy Road
Hartford, CT 06114

Director, Naval Research Lab. (6)
Attn: Code 2627
Washington, DC 20375

Office of Naval Research (6)
Department of the Navy
Attn: Code 102 IP
Arlington, VA 22217

Defense Documentation Center (12)
Bldg. #5, Cameron Station
Alexandria, VA 22314

Commanding Officer (1)
Office of Naval Research Branch Office
495 Summer Street
Boston, MA 02201

United States Naval Post Graduate School (1)
Dept. of Mechanical Engineering
Attn: Dr. R. H. Nunn
Monterey, CA 93940

Defense Advanced Research Projects Agency (1)
Director of Tactical Technology
Attn: Dr. Robert Moore
1400 Wilson Blvd.
Arlington, VA 22209

Defense Advanced Research Projects Agency (1)
Attn: CAPT Cox
1400 Wilson Blvd.
Arlington, VA 22209

United States Coast Guard Research & Technology (1)
Attn: CAPT D. B. Flanagan
400 7th Street SW
Washington, DC 20590

DISTRIBUTION LISTS (Continued)

Dr. Larry W. Noggle (1)
A8D/XRD
Wright Patterson AFB
Dayton, OH 45402

Mr. Robert Ziem (1)
Director Defense Research & Engineering
Pentagon 3D1089
Washington, DC 20350

Mr. James Remson (1)
Headquarters, Naval Material Command
(MAT) 033
Washington, DC 20360

Mr. Zel Lavine, Director (1)
Office of Advanced Ship Development
Department of Commerce
Maritime Administration
Rm. 4610, Code 920
14th & E Street, NW
Washington, DC 20230

Mr. Frank Welling (1)
NSEC, 201
Center Building
3700 East-West Highway
Prince Georges Plaza
Hyattsville, MD 20782

Mr. H. D. Marron (1)
NSEC, 202
Center Building
3700 East-West Highway
Prince Georges Plaza
Hyattsville, MD 20782

Dr. Robert Allen (1)
David W. Taylor
Naval Ship Research & Development Center
Code 012
Bethesda, MD 20084

Dr. Earl Quandt (1)
David W. Taylor
Naval Ship Research & Development Center
Code 272
Annapolis, MD 21402

Dr. F. R. Riddell (1)
Institute for Defense Analyses
Room 9A11
400 Army & Navy Drive
Arlington, VA 22202

DISTRIBUTION LISTS (Continued)

Mr. Charles Miller (1)
Naval Sea Systems Command 03
Crystal City
National Center #3
Washington, DC 20360

END 6-77