

AD-A040 035

MINNESOTA UNIV MINNEAPOLIS ST ANTHONY FALLS HYDRAUL--ETC F/G 13/10
A HYDRODYNAMIC FEASIBILITY STUDY FOR A LARGE, HIGH-SPEED, VARIA--ETC(U)
APR 72 J F RIPKEN, J M WETZEL, F R SCHIEBE N00014-67-A-0113-0027

UNCLASSIFIED

M-132

NL

| OF |

AD
A040 035

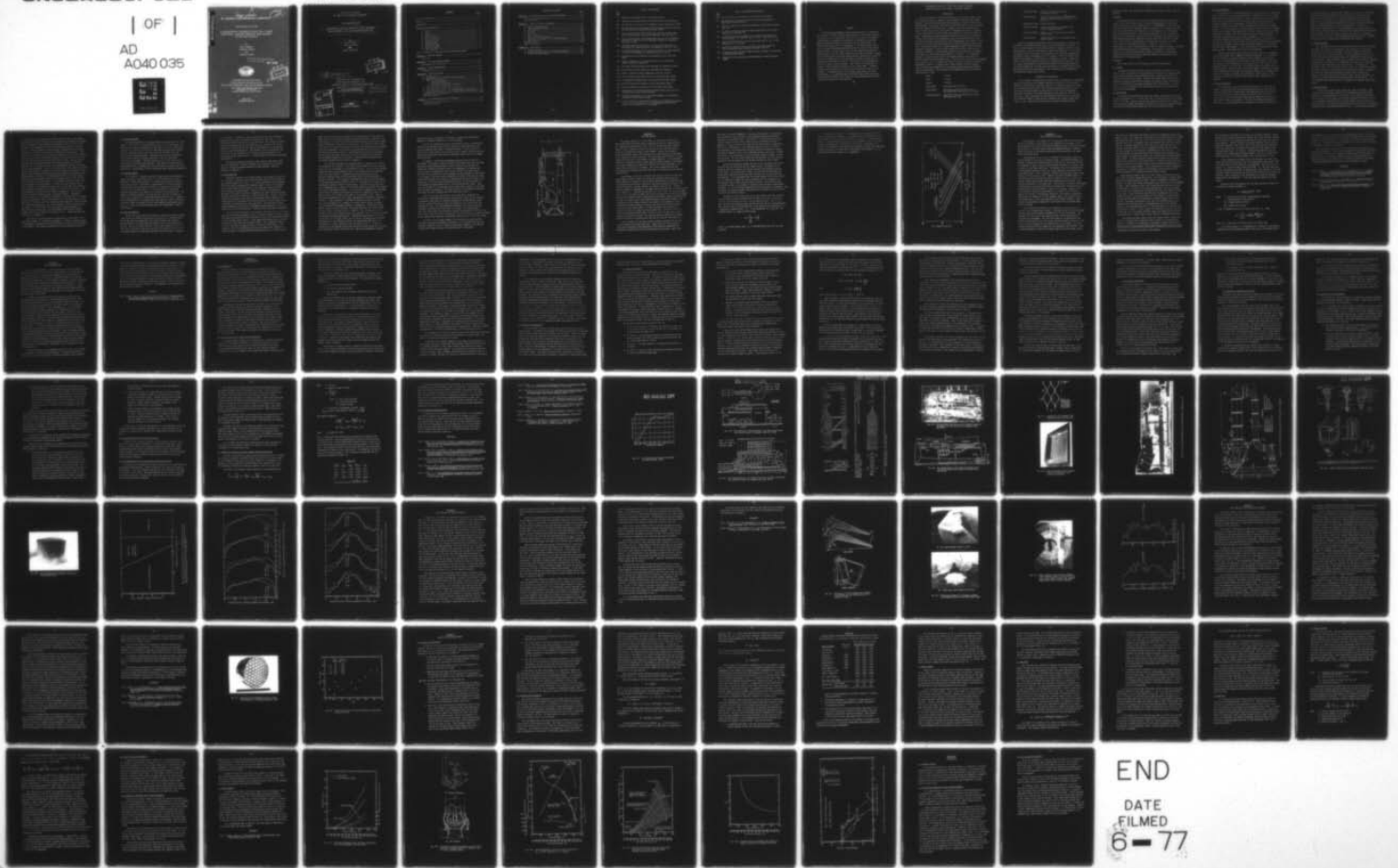

END
DATE
FILMED
6-77

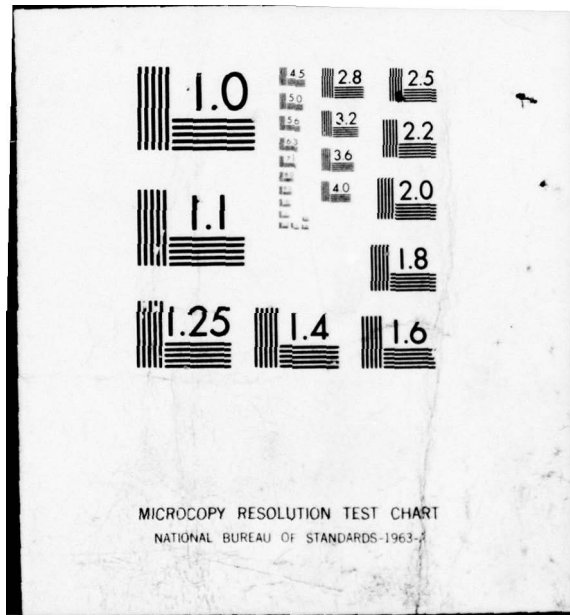

ADA 040035

2 B.S.

UNIVERSITY OF MINNESOTA
ST. ANTHONY FALLS HYDRAULIC LABORATORY

Memorandum No. M-132

A HYDRODYNAMIC FEASIBILITY STUDY FOR A LARGE,
HIGH-SPEED, VARIABLE PRESSURE, FREE SURFACE
WATER TEST FACILITY

by
John F. Ripken,
Joseph M. Wetzel,
and
Frank R. Schiebe

APPROVED FOR public release
distribution unlimited

MAY 19 1977

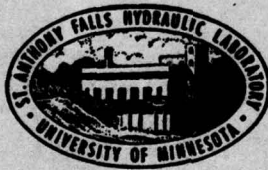

DDC
MAY 31 1977
C

This study was sponsored by the
Ship Performance Department of the
NAVAL SHIP RESEARCH AND DEVELOPMENT CENTER
under Naval Ship Systems Command
Subproject ZF 199 0203
Contract N00014-67-A-0113-0027

April 1972
Minneapolis, Minnesota

AD NO. _____
DDC FILE COPY.

University of Minnesota
ST. ANTHONY FALLS HYDRAULIC LABORATORY

Memorandum No. M-132

6
A HYDRODYNAMIC FEASIBILITY STUDY FOR A LARGE, HIGH-SPEED,
VARIABLE PRESSURE, FREE SURFACE WATER TEST FACILITY

10
by
John F. Ripken,
Joseph M. Wetzels
and
Frank R. Schiebe



17 ZF1990203

This study was sponsored by the
Ship Performance Department of the
NAVAL SHIP RESEARCH AND DEVELOPMENT CENTER

under Naval Ship Systems Command
Subproject ZF 499 0203
Contract N00014-67-A-0113-0027

ACCESSION No.	
NTIS	White Section <input checked="" type="checkbox"/>
DDC	Surf Section <input type="checkbox"/>
UNANNOUNCED	
JUSTIFICATION	
BY	
DISTRIBUTION/AVAILABILITY CODES	
Dist.	AVAIL. and/or SPECIAL
A	

15

11 April 1972

Minneapolis, Minnesota

12 447

313 450

CONTENTS

	Page
List of Illustrations	iv
Abstract	vi
INTRODUCTION	1
FEASIBILITY CONSIDERATIONS	2
A. Depth	3
B. Width	3
C. Length	3
D. Speed Range	3
E. The Free Surface	4
F. Velocity Profile	4
G. Turbulence Level	5
H. Pressure Range	5
I. Temperature Range	7
J. Free Gas Content	7
K. Free Gas Capacity	7
L. Flow Stability	8
Fig. 1 - Schematic of Proposed 60 Knot Free Surface Tunnel	
<u>Appendix A - THE TEST SECTION</u>	A-1
Fig. A-1	
<u>Appendix B - THE TEST SECTION DIFFUSER</u>	B-1
References [B-1] thru [B-3]	B-4
<u>Appendix C - ELBOW CONSIDERATIONS</u>	C-1
Reference [C-1]	C-2
<u>Appendix D - THE GAS SEPARATOR</u>	D-1
A. Introduction	D-1
B. The Mechanism of Air Solution and Dissolution	D-1
C. Types of Air Separators	D-4
1. Gravity Separators	D-5
2. Centrifugal Separators	D-10
3. Momentum or Impingement Separators	D-11
D. Location of the Air Separator	D-12
E. Cross-Sectional Shape of the Air Separator	D-14
F. Air Loading Tests in the St. Anthony Falls 42-Inch Tunnel ..	D-14
G. Energy Loss Studies in the St. Anthony Falls 42-Inch Tunnel.	D-15
References [D-1] thru [D-12]	D-17
Figs. D-1 thru D-15	
<u>Appendix E - THE DIFFUSER FOR THE GAS SEPARATOR</u>	E-1
References [E-1] and [E-2]	E-4
Figs. E-1 thru E-4	

CONTENTS [Continued]

	Page
<u>Appendix F</u> - THE CONTRACTION AND TEST SECTION ENTRANCE	F-1
References [F-1] thru [F-3]	F-4
Figs. F-1 and F-2	
<u>Appendix G</u> - ENERGY AND PUMP REQUIREMENTS	G-1
A. General Considerations	G-1
B. Discharge-Head Relations	G-2
C. Pump Location	G-6
D. Pump Type	G-7
E. Pump Size	G-9
F. Pump Cavitation	G-10
G. Inlet Velocity Distribution	G-12
H. Influence of Entrained Air on Pump Performance	G-12
I. Model Studies	G-13
Reference [G-1]	G-13
Figs. G-1 thru G-6	
<u>Appendix H</u> - AUXILIARIES	H-1
A. Pressure Control	H-1
B. Surface Gas Separation at the Diffuser Entrance	H-1
C. Cooling and Heat Transfer	H-2

LIST OF ILLUSTRATIONS

<u>Fig.</u> <u>No.</u>	
1	Schematic of Proposed 60 Knot Free Surface Tunnel
A-1	Cavitation and Froude Numbers for Various Test Stream Conditions
D-1	The Terminal Rate of Rise of Air Bubbles in Water (from Ref. [D-6])
D-2	The Hydronautics Variable-Pressure, Free Surface Test Facility with Vertical Gravity Air Separator (from Ref. [D-8])
D-3	The Variable-Pressure, Free Surface Test Facility of VWS in West Berlin with Horizontal Gravity Air Separator (from Ref. [D-9])
D-4	The Variable-Pressure, Free Surface Test Facility at the Technical University of West Berlin with Horizontal Gravity Air Separator (from Ref. [D-10])
D-5	The Free-Surface Test Facility at the California Institute of Technology with Tray-Type Gravity Air Separator (from Ref. [D-5])
D-6	The Variable-Pressure, Free Surface Test Facility at the University of Leeds with Tray-Type Air Separator (from Ref. [D-10])
D-7	Configuration of Air Separator Tube Employed in the 6-Inch SAF Tunnel
D-8	General Arrangement of Air Separator Tubes in the 6-Inch SAF Tunnel (viewed from upstream)
D-9	The 6-Inch SAF Water Tunnel with Tube-Type Air Separator at Left
D-10	The 42-Inch SAF Water Tunnel with Tube-Type Air Separator
D-11	Typical Commercial Cyclone Separators (from Ref. [D-11])
D-12	An Air Separator Tube Bundle as used in the SAF 42-Inch Tunnel
D-13	Air Separator Characteristics for the SAF 42-Inch Water Tunnel
D-14	Velocity Profiles at Location I in the SAF 42-Inch Tunnel
D-15	Velocity Profiles at Location III in the SAF 42-Inch Tunnel
E-1	Arrangement of the Two-Dimensional Combined Turning Vane and Flow Diffuser used in the 6-Inch SAF Tunnel
E-2	Prefabricated Elements of the Resistance Members of the Separator Diffuser of the SAF 42-Inch Tunnel
E-3	Partial Assembly of the Resistance Members of the Separator Diffuser of the SAF 42-Inch Tunnel (view looking upstream with separator support plates shown in right foreground)

LIST OF ILLUSTRATIONS [Continued]

Fig.
No.

- E-4 Velocity Profiles at Location II in the SAF 42-Inch Tunnel
- F-1 Honeycomb Flow Straightener Used in 12-Inch Pipe Employed for Free-Surface Stability Tests
- F-2 Effect of Area Ratio on Surface Disturbance of High Speed Circular Free Jets
- G-1 Preliminary Discharge, Head, and Power Requirements for the Pump Proposed for a New Facility
- G-2 Orientation and Bowl Arrangement for Vertical Shaft Pump with a Design Rating of $Q = 850$ cfs and $H = 65$ ft (from Ref. [G-1])
- G-3 Typical Performance Curves for an Axial-Flow Pump of $N_s = 11,700$ Operating at $N = 292$ rpm
- G-4 Matching of Pump Total Head with Tunnel Head Requirements for Various Operating Speeds Assuming the Pump of Fig. G-3
- G-5 Estimated Minimum Cavitation Index Provided in Tunnel at Centerline of Prototype Pump Intake
- G-6 Influence of Air Injection on the Performance of the SAF 42-Inch Tunnel

ABSTRACT

A preliminary hydrodynamic design study was made of a high-speed, free surface, variable pressure water tunnel with a top speed capability of 100 fps in a 3 ft square test section of 20 ft length. The primary objective was to determine the feasibility of modifying the existing NSRDC 36-inch water tunnel to incorporate the new test section. An analysis was carried out of the components of the desired tunnel which led to a proposed tentative configuration that should meet the original specifications. As the design of the critical components exceeds the present state of the art, model studies are strongly recommended. Energy loss estimates based on the preliminary analysis indicate that a pump of about 40 ft design head, 900 cfs discharge, and 4900 delivered HP for maximum head conditions is required. This would require approximately 6400 HP of input electrical energy. These values are considerably in excess of those currently available in the 36-inch tunnel. Increased sizing of the elements in the lower leg of the existing tunnel is also proposed. In consideration of the increased pump, power, and space requirements, it is concluded that the 36-inch tunnel cannot be practically adapted for the new test section and that extensive model testing should be initiated for a new facility.

A HYDRODYNAMIC FEASIBILITY STUDY FOR A LARGE, HIGH-SPEED,
VARIABLE PRESSURE, FREE SURFACE WATER TEST FACILITY

INTRODUCTION

The future success of naval design practice is critically linked to the use of models to provide a practical understanding of new high speed design concepts. Since ever-increasing operating speeds are a fact of life for the naval designer, naval model test facilities must from time to time be reviewed for their adequacy for future needs. Because of the size, complexity and cost of modern facilities of this nature a substantial lead time is involved in their development and early studies are essential to meet the calendar of needs. Preliminary informal preparations have for some time been underway at the Naval Ship Research and Development Center to tentatively define a test facility which might best provide for future hydrodynamic Navy research. This facility, which was to provide especially for bodies operating at high speed near a free water surface, was to permit experimental model studies involving concurrent simulation of both critical gravitation conditions and critical cavitation conditions. Because model studies of these conditions are plagued by a variety of scale effects when modeled at low speed, it is considered essential to conduct model tests at the maximum practical speed and size. Related experience has established that a facility which can provide the necessary test conditions will be a complex and costly structure deserving of extensive development studies. In light of this, recent reviews of future research needs at NSRDC have spelled out the preliminary specifications for expanded facility capabilities. The following are the specifications for the desired test section and flow:

Depth	≈ 3 feet
Width	≈ 3 feet
Length	≈ 20 feet
Speed Range	From near zero to 100 fps
Free Surface	Essentially planar and wave-free at all speeds above critical ($V_c = 10$ fps)
Velocity Profile	Essentially flat over 85 per cent of the cross-sectional area

Turbulence Level	Minimal to simulate an infinite prototype flow field
Pressure Range	From near vapor pressure to ⁴ 2 atmospheres absolute including operating <i>sigma values</i> down to 0.02
Temperature Range	Minimum variation
Free Gas Content	Minimal observational impairment, non-critical dynamic effects
Free Gas Capacity	Ingest at test section exit and remove 200 cu ft/min
Flow stability	Essentially devoid of low frequency pulsations or drift

Since the foregoing specifications bear some resemblance to those of the existing 36-inch NSRDC cavitation tunnel, the first question that arises is, "can the 36-inch tunnel be practically modified or upgraded to meet the new specifications, or do the needs dictate a wholly new facility?" In an effort to formulate definitive answers to this question, the Naval Ship Research and Development Center in September 1971 let a contract to the St. Anthony Falls Hydraulic Laboratory of the University of Minnesota to conduct a feasibility study of the critical problems involved in developing such a facility. The St. Anthony Falls Hydraulic Laboratory was selected for the study because of its earlier experience in similar studies relating to the NSRDC 36-inch tunnel and other Navy facility developments. The resulting study is summarized by the feasibility report which follows.

FEASIBILITY CONSIDERATIONS

In the interest of simplicity and clarity, this consideration of feasibility has been divided into brief summary conclusions relating to the limitations, problems, and feasibility of achieving each of the individual conditions listed in the original specifications. The individual summaries briefly state the concluding findings and where necessary refer to more detailed background discussions contained in the eight appendices which constitute the bulk of the report. These appendices are for convenience broken down into individual flow components which in their entirety constitute the complete tunnel flow circuit. Fig. 1 depicts the form and size of tunnel resulting from this

preliminary study. The specification summaries which relate to Fig. 1 are as follows:

A. Depth

The specified depth of 3 feet poses no particular problems except that in a free surface test section, waves or surface instabilities will inherently occur for velocities in the neighborhood of $V = \sqrt{g \times \text{depth}}$ or about 10 fps. The instability does not preclude operating the tunnel in this speed range, but will impose undesirable test conditions. In consequence, it is recommended that test velocities exceed a value greater than about 15 fps. A number of European free surface test facilities with low-to-moderate speed capabilities have employed mechanically adjustable variable depth test sections to implement a wider control of gravitational or Froude test conditions. In view of the fact that the proposed facility is intended to operate at the extreme speed of 100 fps (stagnation head = 155 ft, stagnation pressure = 70 psi), an adjustable test depth is not recommended. The mechanical, structural, sealing, and surface fairing problems involved in providing a workable and adjustable test section floor are considered excessive when related to the limited merits of variable depth.

B. Width

The elected width of 3 feet imposes no critical considerations.

C. Length

The specified length of 20 feet imposes no critical consideration. However, it must be recognized that boundary friction losses at the maximum speed impose energy demands on the recirculating pump of approximately 30 HP for each foot of test section length. Moreover, the planar qualities of the free surface deteriorate rapidly with increasing test section length. The nature of this deterioration is discussed separately under "free surface". A reduction in test section length is desirable unless a clear case can be made for the 20 feet now specified.

D. Speed Range

Aside from the previously discussed free surface instabilities that occur in the neighborhood of $V = 10$ fps, there are no discrete criticals in the range from 0 to 100 fps. However, since dynamic pressures increase as the square of the velocity and energy requirements increase as the cube, the higher velocities constitute the prime problem source for this entire feasibility study.

E. The Free Surface

The provision of an essentially planar free surface devoid of significant shear breakdown or air entrainment upstream of a selected test site is largely controlled by the contraction design. Earlier studies with fire fighting and turbine jets have demonstrated that air shear does not initially promote surface breakdown and air entrainment, but does so only after kinetic disturbances internal to the water have first distorted or roughened the planar quality. It is the objective of a good contraction design to minimize boundary layer growth, boundary layer separation vorticity, axial corner vortices, and the general turbulence level as the primary source of surface breakdown. In a separate consideration of this problem in Appendix F it is felt that a high quality surface can probably be obtained at 100 fps in the first five to eight ft of the test section length with progressive deterioration thereafter. The available evidence relates to relatively small (approx. 2 in. diameter) circular jets. There appear to be no related data for large, planar, high-speed surfaces. High speed model studies are recommended.

Boundary layer growth and displacement thickness require an expansion of the test section area as the flow proceeds downstream. It is suggested that the channel floor remain horizontal and the channel walls parallel. This will then necessitate an upward slope on the free surface. This slope is considered to be insignificant to test operations in the stream for the operating range of 15 to 100 fps. The skimmer pickup to be provided at the downstream end of the test section is believed capable of absorbing the dimensional changes which will result from varying surface slope. Detailed model tests are necessary to validate this assumption. Model studies are also necessary to evaluate or correct lateral surface waves originating at the sidewalls.

F. Velocity Profile

For simulation of a unified infinite flow field it is important to produce a test section flow of essentially uniform velocity distribution. Previous studies at St. Anthony Falls have established that velocities to within less than 1/2 per cent variation over 85 per cent of the cross sectional area can be achieved by using properly shaped contractions with area ratios of about 9 or greater. With the ratio presently proposed as about 60, it is anticipated that the flatness of the velocity profile will

be exceptionally good. Detailed model studies will, however, be necessary to assure freedom from separation vorticity and axial corner vorticity. These conditions may stem from too rapid boundary pressure changes and boundary layer intersections at contraction corners. Properly designed rates of pressure changes and maximum use of corner filleting are believed capable of adequate control of these secondary flows. The use of an asymmetrical contraction exit, as is recommended, and a shape transition from round to square within the contraction will introduce some new problems, but the burden of their solution is believed justified by the operating benefits which will result. The determination and evaluation of a suitable contraction form will necessitate considerable model testing.

G. Turbulence Level

The turbulence level in the test section should be minimal to simulate the static flow field of the prototype. This turbulence is principally controlled by the level of turbulence entering the approach contraction and the area ratio of the contraction. In the configuration shown in Fig. 1 a very large gas separator and honeycomb are introduced just upstream of the contraction. These components tend to eliminate any turbulence components of large size or strength. It is anticipated that when this is processed through the very large contraction ratio of Fig. 1 (AR approx. 60), the turbulence level in the test section will be quite low. Small-scale studies of various contraction ratios were recently made as described in Appendix F. The concurrent turbulence measurements included therein suggest that eventual turbulence values for the tunnel of Fig. 1 may be only about 3 to 5 per cent in the contraction chamber upstream of the test section. It is recommended that these studies be reevaluated in a complete tunnel model study.

H. Pressure Range

The specified pressure range imposes two types of problems: those relating to the structural loading of the containment housing and those relating to the hydrodynamics of cavitation. The structural problems are not the subject of this study, nor are they considered technically critical to the ultimate construction of the facility despite the high costs which may be involved. The structural problems do in one respect have a significant influence on the configuration adopted in Fig. 1. This relates principally

to the selection of a round cross-sectional shape for most of the tunnel loop which arises from the fact that the pressure drop required for maximum flow acceleration in the contraction approximates 70 psi. If this value is added to one atmosphere of supercharge operating pressure in the test section, a working pressure of about 85 psig is applied to all the tunnel boundaries in the flow reach between the pump and the test section. This includes the air separator and contraction entrance, both of 28 ft diameter. The structural pressure containment problem with these large sections was the major reason for selecting the round cross section. The low or vapor pressure end of the pressure range also imposes substantial structural problems, but is far more critical to the hydrodynamic problems of several of the tunnel components. Since it is the objective of the tunnel to provide severe cavitating test conditions in the test section, the elements of the tunnel circuit between the test section and the pressure elevating pump are also inherently subjected to cavitation possibilities. The most serious problems in these components occur in the entrance region of the diffuser just downstream of the test section, in the vaning of the first elbow, and in the vaning of the pump impeller. Currently the most indeterminate of these elements is the diffuser entrance, and it is believed that extensive high speed model studies will be necessary to resolve this critical. These considerations are treated at more length in Appendix B. The next most serious cavitation problem centers in the pump blading. Fortunately, available prior art, as discussed in Appendix G, indicates that the proposed tunnel configuration of Fig. 1 can operate free of critical pump cavitation problems if a suitable selection of pump and confirming model tests are made by a competent pump builder. Critical cavitation is also a possibility in the vaning of the first elbow, but this possibility has probably been neutralized by the selection of a fairly modest elbow velocity through suitable selection of elbow size as shown in Fig. 1. These considerations are treated in Appendix C.

The nature of the cavitation test conditions to be provided in the test section itself is discussed in Appendix A. Study of a complete model is recommended to determine the mutual influence of these circuit components on one another. This relates particularly to their cavitation criticals.

I. Temperature Range

The continued addition of pumping energy (at maximum speed HP = 4900, BTU/hr = 12.6×10^6) to a finite quantity of water in a water tunnel will progressively raise the temperature of the water. The rate of temperature rise will be a function of the rate of heat addition (pump input energy), the mass concerned, and the rate of loss via the boundaries and heat extraction auxiliaries provided. There need be no critical temperature rise problems involved in tunnel operations if the heat extraction auxiliaries are adequate. Adequate facilities will in this case involve a substantial and costly auxiliary plant. This plant can be minimized by making maximum use of boundary heat loss which can be estimated from model evaluations. Consideration of these factors has been included in Appendix H.

J. Free Gas Content

For a variety of reasons, substantial quantities of gas dispersed as bubbles may exist in the tunnel flow. It is the objective of the gas separator to reduce these bubbles to the extent that they do not significantly impair visual or photographic observations in the test section or introduce other water qualities detrimental to simulation of the dynamic flow process at the test subject. It is not desirable to completely eliminate gas bubbles, but they must be reduced to a tolerable level. The separator structure required to accomplish this reduction is large and costly, and its design is a compromise between several factors. Appendix D gives consideration to the design problem and describes recent preliminary tests which led to the selection of the gas separator configuration shown in Fig. 1. Tests with a more complete model are recommended to clarify a final design.

K. Free Gas Capacity

The use of a free surface test section in a pump recirculated conduit loop involves the problem of returning the free flow to a closed conduit. This return must be accomplished via a pickup skimmer which ingests a minimum amount of air while achieving pickup at velocities varying up to 100 fps. The use of similar pickups in lower speed tunnels has indicated that about 5 per cent of the flow may need to be skimmed off and the bulk of the gas removed in an auxiliary structure before the water is returned

to the tunnel. In addition to this source of free gas, very substantial quantities of gas may be entrained or injected by a test body. It has been specified that this may be as much as 200 cfm. The foregoing actions involve two separate and critical functions, one relating to the pickup skimmer with return flow and the other to the separation of gas ingested into the main recirculated flow. The problems of the pickup-skimmer and return circuit are considered to be the most critical unknowns of the preliminary design shown in Fig. 1. These problems are discussed separately in Appendix B.

The problems relating to removal of gas from the main pump circuit are also substantial, but recent studies at St. Anthony Falls currently provide a reasonably workable solution to these problems. They are discussed in Appendix D.

L. Flow Stability

Meaningful studies of test bodies require a high degree of stability in a test flow. Because of the large mass which would be recirculated in the proposed tunnel loop of Fig. 1, it is not anticipated that the general flow could exhibit any pulsatile character except of quite low frequency. With suitable stability and control of the pump drive, these variations would normally be insignificant. However, in view of the appreciable gas content that may be injected or ingested, the tunnel flow could acquire abnormal elasticity with possible transient variations. Studies in the St. Anthony Falls 42-inch tunnel using a flow stability sensor together with large quantities of gas added both before and after the tunnel pump failed to evidence any instability in the tunnel flow. Some decrease in tunnel speed accompanied the injection of abnormally large quantities of air, but without loss of velocity stability. These tests are described in Appendix G.

The foregoing discussions of the separate specification items, together with the more detailed appendices, serve to briefly summarize the basic tunnel needs and the possibilities and limitations of most of the important elements of the necessary tunnel circuit. These summary discussions do not, however, discuss the tunnel pump and its special needs. For a comparable summary it can be said that the pumping needs of the tunnel shown in Fig. 1 can probably be met by a variable-speed fixed blade pump of the propeller or axial-flow type. The required maximum head of about 48 ft is about at the

upper limit of prior art for a purely axial flow machine, but with suitable model tests by the selected pump maker, procurement should be possible. The selected pump will require approximately 6400 horsepower of electrical energy under the estimate of severest load conditions. The estimate of power needs is believed to be fairly conservative, but more detailed studies in a complete model are recommended. The estimates of operating pressure conditions at the pump location shown in Fig. 1, when compared with available experience data, indicate that pump cavitation limits will not serve as a constraint on the proposed operation of the tunnel. More detailed considerations of the energy and pump needs are given in Appendix G.

It is evident throughout the foregoing specific summaries that, with a few exceptions, the elements of the tunnel circuit appear to pose no critical barriers to the development of the proposed facility. The most serious design questions relate to the downstream end of the contraction and the upstream end of the main diffuser. Although these areas admittedly constitute difficult problems, they are with sufficient effort believed amenable to practical solution. It is strongly recommended that any further development of the preliminary design concept of Fig. 1 be initiated with extensive pilot experimental studies of these critical areas. In parallel and in addition, it is recommended that a model of the complete tunnel be assembled and studied for overall performance qualities. It is, moreover, suggested that consideration be given to adapting the present 42-inch St. Anthony Falls tunnel as shown in Fig. D-10 to serve as the model of the complete tunnel. Many of the existing components of this tunnel approximate the comparable components of Fig. 1. These components, including the separator-diffuser and pump, are not only expensive to reproduce, but would involve delays to procure if an accelerated development program is contemplated. The assembly would permit a model of about 1/4 scale. This model should be run at the highest practical speed, including 100 fps if possible. The existing drive at St. Anthony Falls does not presently have this capability, but it could conceivably be attained with some modifications. Modification and testing of this 1/4 scale model will be fairly costly, but is not out of keeping with the nature and magnitude of the problems involved in a conservative approach to the development of a major facility of the type shown in Fig. 1. It must be recalled that the proposed free-surface facility involves speed and size which more than double those of the prior art. Since most hydrodynamic problems

grow with at least the square of the speed, a careful and conservative approach is considered mandatory in this development.

Although the proposed 1/4 scale model would be costly, a considerable return on the investment could accrue through its early availability for pilot hydrodynamic model ship or component studies. Its test section of about 9 by 9 inches would be of sufficient size to support valuable modeling experience during those years when the prototype tunnel would be in design and fabrication.

In summary, a preliminary hydrodynamic design study was made for a high speed, free surface, variable pressure water tunnel that would meet the previously stated specifications. In order to achieve the desired flow conditions, attention was given first to the components in the upper leg of the circuit (air separator, test section, diffuser, and first elbow) and then to the influence of these components on the remainder of the circuit. In an attempt to utilize as much information as possible from previous lower speed tunnel designs with a history of satisfactory operation, sizing of the components in the lower leg was determined so that the flow velocities in these components approximated those in the existing 36-inch tunnel. Head loss calculations for the complete circuit permitted an estimate of the pump and total power requirements. Pertinent features of the proposed configuration based on these considerations have been shown in Fig. 1.

One of the initial objectives of this study was to determine the feasibility of modifying the existing 36-inch water tunnel for this purpose. It should be noted that the proposed configuration is considerably longer than the existing facility and that the elements of the circuit have been increased in size. The head-discharge requirements of the pump have been increased, resulting in the selection of a similar, but larger-diameter unit with fixed blades delivering about 4900 HP and demanding an electrical input of about 6400 HP. The 40 ft design head, 900 cfs discharge, and 4900 delivered HP for maximum head conditions considerably exceed those in the 36-inch tunnel.

In view of the increased demands of the desired high speed facility for space, pump head and capacity, and power, it is concluded that the configuration depicted in Fig. 1 cannot be practically adapted to the existing 36-inch water tunnel and that a new facility must be considered.

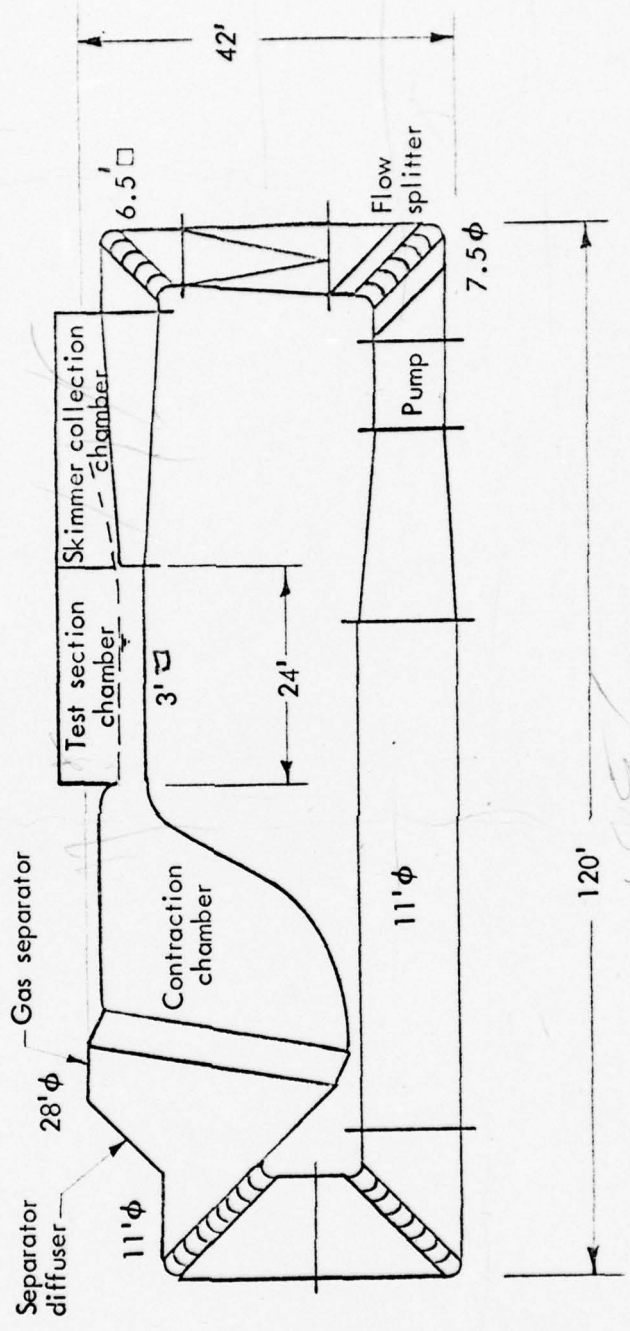

Fig. 1 - Schematic of Proposed 60 Knot Free Surface Tunnel

Appendix A
THE TEST SECTION

The primary purpose of a water tunnel is to provide a high quality flow stream that will permit proper simulation of the flow characteristics of a body moving through still water. Most of the existing water tunnels employ either a closed test section or an open jet test section, both of which are submerged and without a free surface. Current and projected naval applications require the investigation of bodies moving at high speed in the presence of the free surface. For such experimental studies, the test stream must also have a free surface for proper modeling. In the proposed tunnel it is desired to create a high quality variable pressure, free surface test stream flowing with a velocity of 100 fps (~ 60 knots) through a 3 ft square cross section of 20 ft length. Such a test stream would provide the capability of modeling both the effect due to cavitation and the vertical gravity field.

Some concept of the test conditions that could be achieved in the proposed tunnel is given in Fig. A-1, where the cavitation number based on vapor pressure at 60 and 80 F and the Froude number based on depth below the free surface are plotted as a function of velocity and ambient pressure. The range of velocity of current interest is between 15 and 100 fps. With the ambient pressure at atmospheric, the vapor cavitation number for a velocity of 100 fps is about 0.2. Reducing the pressure to 0.1 atm. lowers the cavitation number to 0.02. The effect of depth below the free surface on the cavitation number that can be attained is minor, particularly at the higher ambient pressures, but it does, of course, have a more marked influence on the Froude number. The flexibility of the variable pressure free surface in the modeling of both cavitation and Froude numbers is obvious, and since the velocity is established by a given Froude number, the ambient pressure must generally be reduced to achieve the proper cavitation conditions. As shown in Fig. A-1, the critical unstable Froude number of unity in the 3 ft deep test section occurs at a velocity of 10 fps. To avoid the surface instabilities inherent near this velocity, a minimum useful velocity of 15 fps is being specified.

The flow quality of the test stream is greatly influenced by the contraction producing the high speed flow. Small ratios of the contraction areas permit moderately high turbulence levels which are undesirable for modeling an undisturbed flow field entering the test section. High levels

also lead to an early breakdown of the moving free surface. The extremely large contraction ratio inherent in the proposed design should provide a desirably low turbulence level. The effects of contraction ratio and contraction length on test section stream quality are discussed further in Appendix F. The air shear on the high velocity free surface is expected to result in air entrainment in the downstream reaches of the test section. The magnitude of this disturbance has been partially determined in studies discussed in Appendix F, but is not completely known at this time. Further indications of the disruption of the free surface should be sought in later model studies. For test bodies placed near the entrance, the free surface upstream of the body should not be seriously affected by the air shear.

As the flow progresses through the test section, boundary layers will grow from the two side walls and the channel bottom. The growth of the boundary layers will distort the velocity profiles and generate vorticity at the walls. To eliminate wall effects, the test body will generally be sufficiently removed from the walls that the effect of the wall shear will be minimized. It is anticipated that the bottom corners of the test section will be filleted to reduce the vortex disturbance due to intersection of the boundary layer on the side walls and the bottom. The bottom can also be sloped to allow for the change in effective flow area due to displacement thickness. It is not currently proposed that the flow depth be changeable. The structural and sealing problems associated with a movable floor are believed to exceed its operation values.

Estimates of the friction loss in the test section were made assuming that the boundary layer development was the same as that for a flat plate with the same wetted flow area in a zero pressure gradient. For the high speed flow the high Reynolds number necessitated the use of the Karman-Schoenherr friction line in the determination of the skin-friction coefficient C_f . A comparative headloss factor, K_o , in the expression $h_f = K_o V_o^2 / 2g$ was evaluated using C_f values in the relation

$$K_o = \frac{h_f}{\frac{V_o^2}{2g}} = C_f \frac{A_w}{A_o}$$

where A_w = wetted channel area, A_o = cross-sectional area, and V_o = mean velocity.

At present, the origin of the boundary layer development cannot be specified precisely, although it is recognized that the development in the flow contraction will be carried into the test section. For present purposes it is assumed that the origin is at the entrance to the test section and that the length to be considered is thus 20 ft. Furthermore, the effects of the corners on the test section friction loss have been neglected, as have the effects of a test body in the stream. The values of K_0 so calculated are given in Table G-1 of Appendix G.

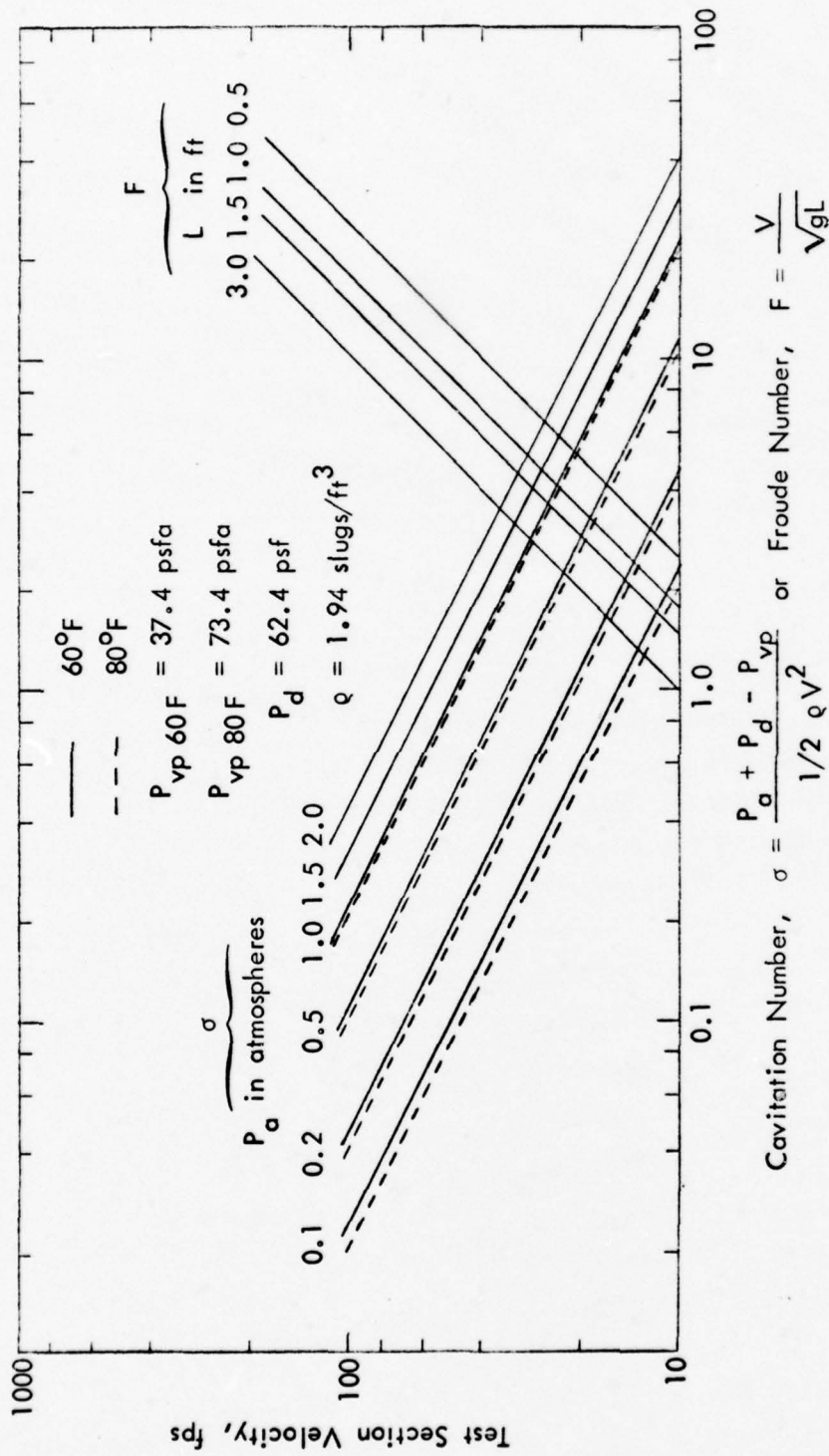

Fig. A-1 - Cavitation and Froude Numbers for Various Test Stream Conditions

Appendix B
THE TEST SECTION DIFFUSER

The function of the diffuser is to efficiently reduce the high velocity of the test stream to lower values in the remainder of the tunnel circuit. This reduction in velocity in the tunnel elements results in lower head losses in the system. The lower velocity and corresponding increase in pressure also relieve some of the problems associated with cavitation in the vaned elbows and pump blading.

In deceleration of the flow it is desired to efficiently convert the kinetic energy of the stream to pressure energy. The inherent tendency of a diffuser to distort the velocity profile at the exit of the diffuser should be minimized to reduce losses in other elements following the diffuser, particularly in the first vaned elbow. The pressure rise in the diffuser must be sufficiently moderate to avoid or at least minimize flow separation on the boundary walls. This is generally achieved by using small rates of area change in the direction of flow. However, for small divergence angles of the diffuser walls the length required to expand the flow to a given exit section becomes large and the associated boundary friction becomes a significant percentage of the energy loss. On the basis of extensive experimental investigations it has been found that the optimum total included angle for a straight-walled conical diffuser is about 5 to 7 degrees. Another factor that strongly influences the performance of a diffuser is the velocity profile at the inlet. The pressure recovery of the diffuser is adversely affected by the presence of a thick boundary layer in the entering flow or by the addition of a test body upstream of the diffuser entrance. These effects are particularly emphasized for diffusers with an included angle near the optimum.

Several additional problems are encountered in the selection of a diffuser for the proposed water tunnel. The high speed flow passing through the test section will entrain considerable air at the free surface. The presence of a test body in the stream will also create disturbance and resulting air entrainment. For most test bodies it is expected that the highest concentration of air will be near the free surface and that the free surface near the entrance to the diffuser will be very rough. For stable diffuser operation the flow should fill the entrance to the diffuser. Thus it seems imperative to skim off the upper layer of the test stream, remove

most of the air, and return the skimmed liquid to an appropriate part of the tunnel circuit. Past experience with lower velocity free-surface water tunnels has shown that about 5 per cent of the total flow should be skimmed. In the proposed facility it is suggested that this quantity be diverted by a pickup lip into a separate chamber where the velocity is reduced and some air is removed. This water would be injected tangentially back into the tunnel near the entrance of the diffuser at essentially the local velocity. It is thus anticipated that the high energy fluid injected at the boundary will greatly assist in maintaining a stable flow in the diffuser through boundary layer control. In order to provide sufficient flow velocity an auxiliary pump will be required for the injected fluid. It should be noted that a discharge in excess of 40 cfs and a pump of several hundred horsepower may be involved in this by-pass system. Other alternatives are noted in Appendix H. The design of a suitable pickup lip and boundary injection system at the diffuser entrance will necessitate extensive model studies.

Even though the upper layer of the test stream is diverted, some gas will still be carried through the diffuser. As the pressure increases while the mixture flows through the diffuser, energy is expended in compressing the gas. For small (by volume) percentages of gas this effect can be regarded as small. Tests described in Ref. [B-1]* have indicated that the reduction in efficiency is related to the volume concentration of gas in the liquid. With a 5 per cent concentration the diffuser efficiency was reduced by about 3.5 per cent. These tests were conducted with a homogeneous flow of gas bubbles and liquid, and the possibility of the existence of large bubbles or slugs of gas formed by the coalescence of smaller bubbles was not considered. The uneven distribution of air that will probably exist in the proposed test stream may result in nonhomogeneous flow in the diffuser entrance. The nonhomogeneity may set up flow instabilities in the diffuser which might be serious. In this regard, the previously mentioned injection of the water into the diffuser entrance region will hopefully provide additional stability. A model study of these factors is considered necessary.

The essentially square test section will require either a square diffuser or a diffuser with a transition from a square to a circular cross section. At present it is proposed to investigate a square diffuser with transition to a circular section taking place downstream of the first elbow.

*References are listed at the end of each appendix.

Filletts would be installed in the corners of the square sections. Experimental data for square diffusers are limited; most tests have been carried out with conical or two-dimensional diffusers and relatively low ratios of area expansion. However, some data for square diffusers of the type proposed are presented in Ref. [B-2]. Here it is shown that the total diffuser loss coefficient was essentially constant over the range of total included angles from 5 to 7 degrees. To keep the diffuser as short as possible, the 7 degree angle has been selected. For the 3 ft square diffuser inlet and 6.5 ft square diffuser outlet the area ratio is 4.72.

In the computation of energy loss in the diffuser, the total loss coefficient has been referred to the test section mean velocity head. The loss coefficient can be divided into two components: the form loss coefficient, K , and the friction loss coefficient, K_f . The form loss coefficient is primarily a function of geometry and is not expected to vary significantly with flow velocity; the value from Ref. [B-2] can be used for an estimate. After correction of the coefficient to account for different definitions of the head loss, K has been taken as 0.0686 for the bare tunnel.

From Ref. [B-3] the expression for the head loss due to friction on the walls of a conical diffuser is

$$h_f = \frac{f}{8 \tan \theta} \frac{1}{2g} [\bar{V}_1^2 - \bar{V}_2^2]$$

where θ = one-half of the total included angle of the walls

f = Darcy-Weisbach friction factor

\bar{V}_1 = average entrance velocity

\bar{V}_2 = average exit velocity

If \bar{V}_1 is assumed to be the test section velocity, V_o , then

$$K_f = \frac{h_f}{V_o^2/2g} = \frac{f}{8 \tan \theta} \left[\frac{(AR)^2 - 1}{(AR)^2} \right]$$

where AR is the ratio of the large area to the small area.

The friction factor f is determined as a function of the boundary roughness and the mean Reynolds number of the flow in the diffuser and is

thus assumed to be the same as for a fully developed pipe flow. Since the diffuser is of square cross section, the above equation derived for a conical diffuser is directly applicable. The values of K and the total loss coefficient K_o , including the calculated values of K_f for various velocities, are tabulated in Table G-1, Appendix G.

The influence of a body in the test stream on the diffuser loss is difficult to establish. For the present purpose it was arbitrarily elected to assume that the form loss coefficient doubled and the friction loss remained the same. It should be emphasized that the above estimates are rather crude, and model studies of the diffuser and pickup lip are needed to assess performance and flow stability in the system as a whole.

REFERENCES

- [B-1] Crabtree, D. L.; Schmeiter, G. R.; and Murthy, S. N. B., An Investigation of Two-Phase Gas-Liquid Mixtures Flowing in Variable Area Ducts, Part A, Nozzle Flows and Part B, Diffuser Flows, Jet Propulsion Center, Purdue University, 1963, 19 p.
- [B-2] Henry, J. R.; Wood, C. C.; and Wilbur, S. W., Summary of Subsonic-Diffuser Data, NACA RM L56FO5, October 1956.
- [B-3] Ripken, J. F., Design Studies for a Closed-Jet Water Tunnel, Technical Paper No. 9-B, St. Anthony Falls Hydraulic Laboratory, August 1951.

Appendix C

ELBOW CONSIDERATIONS

The flow turning elbows of a recirculating test loop are normally employed to provide 360° of controlled turning action. For practical use in a water facility the important requirements of an elbow design are energy losses which are not excessive, reasonably compact size, minimum detrimental contributions to the discharge flow quality in terms of velocity profile abnormalities, large scale turbulence and flow stability, freedom from cavitation, and a form suitable for practical fabrication. A long history of study and development in wind tunnel and water tunnel practice has led to the current satisfactory employment of the vaned 90° miter elbow for most modern installations.

A resumé of the general problems and a specific solution for an analogous problem can be found in the development studies of Ref. [C-1] for the vaned elbows used in the existing NSRDC 36-inch water tunnel. In view of the extensive studies made of the vaned elbows for this facility and of the relative success of their subsequent use, it is recommended that the same basic design be employed for the proposed new facility. It is recognized that in the years since the study of Ref. [C-1] a substantial amount of theoretical and experimental research has been given to cascade elements. While it is possible that more sophisticated vane forms might be employed for a small measure of improvement over the simple forms of Ref. [C-1], the gains to be had are not believed worth the effort of a new validation. If the early design is employed together with sizing to provide about the same level of maximum velocity as in the former application, adequate performance can be anticipated. Since the design discharge of the proposed facility is 50 per cent more than for the existing facility, maintenance of the same level of velocity values will require a 50 per cent increase in elbow area and about a 25 per cent increase in elbow diameter. This will in turn require additional strengthening and stiffening of the vane structure. Such structural enhancement is not considered to present a serious problem.

The elbow members of the recommended facility of Fig. 1 are intended to be designed in accord with the foregoing. It should be noted that in this figure the pump elbow and the two elbows preceding the gas separator

are circular in cross section. This shape is recommended because it permits a relatively simple structure in accommodating the high pressures to be employed in operation (≈ 70 psi working pressure and ≈ 100 psi design). The fourth elbow, the one downstream of the test section, is shown as square. The elbow could have been made circular, but the required shape transition from a rectangular test section to a round pump section has been concentrated in the vertical leg leading to the pump, and the main diffuser, which is plagued by a number of difficult operational problems, is thus divorced from any involvement with shape transition. In consequence, the attached elbow remains square in section.

REFERENCE

- [C-1] Ripken, John F., "Vaned Elbow Studies," Chapter 5 of Design Studies for a Closed-Jet Water Tunnel, Technical Paper No. 9-B, St. Anthony Falls Hydraulic Laboratory, University of Minnesota, 1951.

Appendix D
THE GAS SEPARATOR

A. Introduction

Small air bubbles in the test water of a cavitation tunnel are usually essential for the proper simulation of cavitation on models. Extensive studies conducted at the St. Anthony Falls Hydraulic Laboratory for the Navy [D-1,D-2,D-3,D-4] have established that under the low pressure conditions existent in most tunnel tests, meaningful inception cavitation data require free air nuclei in concentrations of about 2 to 10 parts per million by volume in diameters ranging from about 0.02 to 0.15 mm. Such bubbles will readily serve as nuclei for the rapid growth of vapor cavities encountered in limited or transient cavitation without significantly hampering visual or photographic observation of test subjects or impairing the dynamic performance characteristics of either the test models or the test facility. For studies of more fully developed or supercavitation, small air nuclei are less important, but excessive air can still impair proper performance and observation.

Maintenance of the desired spectrum of air nuclei in a closed circuit cavitation facility requires the presence of special components in the tunnel loop for nuclei control and special pre-test adjustment of the air content of the water. The air resorber and tray-type air separator which were developed at Cal Tech in the 1940's [D-5] and the tube-type air separator developed at St. Anthony Falls in the mid-1950's [D-1] appear to provide an adequate air control for the types of studies which have been conducted in closed jet water tunnels in the past. The current problem of evolving a design for a large, free-surface, recirculating, variable pressure facility capable of speeds up to 100 fps with air injections up to 200 cfm poses a new problem. This appendix discusses and attempts to resolve the air control problem.

B. The Mechanism of Air Solution and Dissolution

Cavitation tunnel studies may be concerned with cavitation conditions ranging from inception or desinence to large pseudo-steady and "super" vapor cavities or may involve air ventilation or artificial cavitation. For the proposed new facility this range of test conditions imposes a requirement of free air contents at the tunnel test section entrance ranging

from near zero to about 10 volume parts per million and at the test section exit from near zero to about 3000 wppm. Obviously, if the rate of free air discharge at the test section exit exceeds that desired at the test section entrance, resorption or separation and removal of the excess must be provided for in the tunnel loop.

For a given tunnel and flow conditions involving no addition of air in the test section, a stable spectrum of test section air bubbles will usually evolve for a selected steady velocity. This spectrum will depend largely on

1. The water quality and temperature.
2. The total air content in wppm.
3. The time, pressure, and turbulence characteristics of the tunnel loop.

The use of treated water with periodic changes will normally assure high quality water. It is possible to add surfactants and organic skin controls to change the surface tension, but the complexities of this are generally considered undesirable. It is also possible to control the temperature, but in most cases it is desirable to maintain this nearly constant.

Air content, as mentioned in item 2, can be preadjusted to a value higher than an initial value by operating the tunnel under an increased pressure and velocity condition with an adequate free air supply for a prolonged period. The process of adjusting upward is not too time-consuming, but in large tunnels without air separators, adjusting the air content downward may require several hours of running time to achieve a new air adjustment. In the St. Anthony Falls tunnels, which are fitted with special tube-type gas separators, reduction in total gas content from a high value of 20 wppm to a low value of 6 wppm can be achieved in about 25 minutes. Increases in gas content can be made even more rapidly, and changes from a total content of 5 wppm to one of 25 wppm have been completed in about 5 minutes.

The ability of a tunnel circuit to control air content as mentioned in item 3 above involves processes of both air re-solution and air dissolution. Both processes depend on the fact that the water has an inherent inclination

to dissolve a certain amount of air for a given pressure and temperature condition. If the dissolved air is less than this inherent saturation value, undersaturation exists and available free air can pass into solution. If the dissolved air is excessive, supersaturation exists and effervescence or dissolution occurs. The rate at which stability of saturation is approached depends considerably on the existing turbulence structure, and this in turn depends on the head lost in the tunnel loop. Turbulence is important in that it promotes rapid diffusion of the air into or out of the water through its shearing and mass transfer mechanisms. However, to the extent that accompanying fluctuating pressures produce rectified diffusion, turbulence may contribute more to air release than to air solution.

In examining the pressure gradients of most water tunnels it will be noted that with high velocity conditions, low pressures occur only in the vicinity of the test section. Other local low pressures may occur in the vicinity of the elbow and pump vanes or blades. It is only in these regions that dissolution can normally occur. The remainder of the tunnel loop is usually under sufficient pressure that available free air is normally in process of solution. The length of this high pressure reach and the tunnel test velocity are important influences on this solution rate. Test velocity is significant because as it increases, the resident time at high pressure decreases. More important, though, is the fact that the pressure in the high pressure reach increases as the square of the velocity because of the back pressure developed at the usual test section contraction. In a simple tunnel loop operating at high speed the dissolution and re-solution processes result in a usable spectrum of air nuclei in the test section only if the air content is carefully preadjusted to a proper value. Typically, tunnels are operated so that the test section water is at the saturation value.

The intended use of high air injection rates in the proposed new facility eliminates the usefulness of further consideration of a simple tunnel loop due to its inability to remove the free gas.

A resorber is an optional component of the tunnel loop positioned so as to expose the water to additional gravitational pressure concurrent with a substantial increase in the volume of water, thus permitting a greater resident time at the high pressure. By improving the re-solution characteristics of a tunnel loop, a resorber enables water with a greater total air content to be used. However, the initial air content must still be carefully

preadjusted if a given spectrum of air nuclei is to be maintained in the test section. Any attempt to introduce additional air anywhere in the loop will again increase to unusable values the amount of free air entering the test section. In view of the large amounts of air that will be entrained or injected in the test section of the proposed facility, a re-sorber has been dropped from consideration as an alternate means of air control.

An air separator is an alternate component that can be added to a simple tunnel loop to control the free air. Many forms of air separators have been conceived, and a moderate number have been developed for use in test facilities. Further discussion of these forms will be found elsewhere. Suffice it to say that a suitable separator removes the excessive free air from the water in the course of its flow between the test section exit and entrance. The location of the air separator in the loop has various options, which will also be discussed later, but these units have generally been positioned immediately downstream of the test section and have in a few instances been placed just ahead of the test section. In either position it can remove air excesses that may have been introduced in the test section by injection or entrainment. A separator just upstream of the test section can also remove excess air generated by dissolution in the tunnel loop. In addition, because of the lower velocities just upstream of the test section, the energy dissipation is considerably lower. It is this latter location of separator that is used at St. Anthony Falls and is the focus of evaluation and discussion for use in the proposed new NSRDC high-speed facility.

C. Types of Air Separators

The unit weight of free air is only about one-tenth of one per cent of that of water. For bubbles this provides an inherent gravitational instability and tends toward phase separation whenever free gas exists. Where conditions permit, gravitational separation is the simplest separation process that can be employed, but under some circumstances artificial acceleration of the natural process may be desirable through application of an external force. While a number of sophisticated systems involving electrical and acoustic force fields have been employed for additive acceleration, they are not considered practical for air separation of the large flows to be involved in the proposed tunnel. The current discussion will, therefore, be confined to those force systems which might conceivably be adaptable to tunnel application.

These are considered to be the gravity force, the centrifugal force, and the momentum force. They will be discussed separately as follows.

1. Gravity Separators

The separation of air bubbles from water is closely tied to the physical size of the bubbles involved. The size is in turn quite dependent on the previous history of the bubble. It should be noted that bubbles exist as a finite entity in water because of an inherent interfacial tension force. This force is sufficiently strong that several small bubbles coming in contact very readily coalesce into one large bubble, and continuing growth by this process is difficult to arrest in quiet water. Contaminants in the water tend to reduce the surface tension force and weaken the coalescing action. The inherent surface tension force of even pure water is too weak to resist mechanical shear of any consequence. Therefore, those regions of the tunnel loop which involve high shear by reason of high turbulence or head loss will lead to bubble rupture and air dispersion with reduction of bubble size. Hence separation of gas will be encouraged by the provision of regions of low shear or low velocity. In such regions the rate of separation of the gas is dependent on the rate at which the bubbles coalesce and rise. Because of the strong gravitational force that exists for an air bubble in water, acceleration to a terminal rise velocity is rapid, and separator design is largely controlled by this terminal velocity. Extensive studies [D-6,D-7] have been made to determine this value, and they are summarized in Fig. D-1.

The following points should be noted in Fig. D-1:

1. In the region marked "A" the bubbles are spherical in shape and the rectilinear motion is similar to that of a rigid sphere and is approximated by Stokes' Law.
2. In region B, with increasing velocity, circulation within the bubble commences, the motion becomes twisting and helical, and the bubble shape tends to flatten.
3. In region C a major transition is taking place and motion is irregular.
4. In region D motion is again rectilinear in nature and the bubble has a distorted mushroom shape.

It may also be timely to note certain other pertinent points with regard to bubble size and use in a water tunnel as determined in tests in the 6-inch tunnel at St. Anthony Falls, which is fitted with a tube-type air separator.

1. With the water tunnel preadjusted to produce a useful spectrum of air bubble nuclei, bubble diameters smaller than about 0.02 mm and larger than about 0.15 mm do not seem to exist in significant volume in the test section [D-3,D-4].
2. Surface tension forces for bubbles in the size range of item 1 are sufficiently weak that the bubbles serve as nuclei for rapid vaporous expansion or cavitation with only moderate depressions of pressure. Under these conditions, inception cavitation tests should show evidence of only minor scale effects.
3. The smallest bubble that is visually detectable under good lighting conditions is about 0.004 cm in radius.
4. Bubbles of a diameter larger than about 0.05 cm will significantly impair visual observations if present in substantial numbers. Even smaller bubbles will reduce visibility in large numbers. The milky character caused by small bubbles in concentrations of 100 to 200 ppm by volume may eliminate visibility in the test water completely.

For the above conditions it appears that an air separator for a cavitation tunnel should remove bubbles with a terminal rise velocity as low as about 5 cms. On the other hand, Fig. D-1 implies that terminal rise velocities greater than about 30 cms are unlikely.

A number of low- or moderate-speed water tunnels and channels have had air separators based on such gravitational principles and have utilized a selected expansion of the conduit cross section to provide a simple settling chamber. Figures D-2, D-3, and D-4 show a variety of existing forms of this type of separator including both vertical and horizontal settling chambers. However, if these design principles are applied to the presently proposed facility, which is to have a maximum test section velocity of 100 fps and a discharge approximating 900 cfs, the necessary general chamber dimensions would be approximated as follows: Assume that the mean velocity in a cylindrical horizontal chamber of length L and diameter or depth D is

V_m . Further assume that secondary flows or turbulence do not interfere with or distort the terminal rise velocity of the design bubble (0.05 cm diameter) and that this value is $V_T = 5 \text{ cms} = 0.164 \text{ fps}$ from Fig. D-1. For these conditions the required value of L will be established by the time it takes for the design bubble to rise through the distance D , or

$$\text{Rise time} = T_R = D/V_T$$

$$\text{for } Q = 900 \text{ cfs, } V_m = \frac{Q}{A} = \frac{900}{\frac{\pi}{4} D^2}$$

and

$$L = V_m T_R = \frac{4}{\pi} \frac{900}{D^2} \frac{D}{V_T}$$

arbitrarily assuming $D = 30 \text{ ft}$ gives $L = 233 \text{ ft}$.

Quite obviously, a single settling tank of this magnitude would be a very costly structure, and alternate solutions to the gas bubble problem should be sought. A fairly simple approach to size reduction is available through subdivision of the depth D into a large number of units, each having a small vertical dimension. This subdivision can be achieved by inserting suitable shallow inverted pans to collect the rising bubbles in many units for removal from the tunnel. Tray systems of this kind were used in the variable pressure water channel at Cal Tech about 25 years ago, as shown in Fig. D-5, and more recently at the University of Leeds as shown in Fig. D-6.

The St. Anthony Falls air separator is a modification of the tray separator and employs small tubes rather than trays. It was conceived and developed at St. Anthony Falls about 15 years ago. It was first installed in the 6-inch water tunnel as shown in Figs. D-7, D-8, and D-9.

The selected tube configuration as shown in Fig. D-7 represented a compromise between those which might be preferred for flow control and those which could be practically fabricated for mass installation in a water tunnel. Those configurations which offered promise of development were fabricated to prototype size and, in a small-tank test setup, exposed to gasified flow conditions approximating those to be expected in the tunnel.

These comparative tests eventually led to the selection of a flow tube with a crown shaped to a sharp inverted V in which a greatly thickened boundary layer developed. Bubbles which manage to gravitate upward into this boundary layer within the length of the tube are exposed to relatively low velocities and a weakened transporting system. With the tube axis tilted downward in the direction of flow, the bubbles coalescing in the crown of the tube are subject to a gravitational-force component acting upstream along the top of the tube.

With appropriate adjustment of the tube slope and the mean flow velocity, it has been established that it is practical to promote the collection and upstream movement of nearly all but the smallest sizes of bubbles passing through the tube. To promote general collection of the bubbles, the individual tubes are provided with holes near the upstream end. These holes permit the bubbles to gravitate from one tube to the next above. In the case of the water tunnel, the bubbles progress upward through the tube stack to the top of the tunnel conduit, where they are collected and drawn off for disposal or controlled return to the tunnel.

Pilot studies of various tube configurations and arrangements led to the use of standard, galvanized corrugated steel sheets stacked to produce the desired tube arrangement as shown in Figs. D-7 and D-8.

The pilot studies showed that a tube length of 3 ft having a tube slope of about 20 degrees with the horizontal and a mean velocity of not more than 1.0 fps would collect substantially all of the bubbles larger than about 0.03 inches in diameter. While it would have been desirable to reduce this minimum separation value to the preferred 0.01-in.-maximum nucleus size, the higher value appeared to be a practical limit. It should be noted that the value of 1.0 fps is not critical. Substantially larger values can be used if a small number of larger bubbles are considered tolerable.

The separator tubing of Fig. D-8 is introduced into the circuit of the tunnel in the low-velocity region upstream of the contraction as shown in Fig. D-9. At the downstream end of the separator, a flow-straightening honeycomb is provided. This honeycomb, of thin sheet metal, is composed of cells about 1/4 inch in diameter and 3 inches in length with axes parallel to the tunnel test section. This serves as a flow straightener or turning

vane and a large-scale turbulence suppressor. The flow straightener is followed by a contraction approach chamber which allows some turbulence decay in the flow before entrance to the contraction.

The 6-inch tunnel with this separator was used in tunnel gas nuclei studies for many years with good results, but without detailed evaluation of its characteristics.

The same general separator design concept was used in the more recent 42-inch tunnel at St. Anthony Falls shown in Fig. D-10. This design differed only in the use of a standard fiberglass-reinforced plastic in place of the galvanized steel of the earlier tunnel. The corrugated material was in this case approximately 1/16 inch thick with a corrugation pitch of 2.67 inches and a corrugation depth of 7/8 inch. To permit gas migration the corrugated sheets were fitted with seven holes near the upstream end of each corrugation and the sheets were riveted together with aluminum rivets to form tube bundles as shown in Fig. D-12. These bundles, of 27-inch length, were nine in number and were fitted to fill the cross section of the air separator housing. The bundles were supported by a grid of metal plates as shown in Fig. E-3 and were positioned at a 20° angle with the horizontal as shown in Fig. D-10. Air gravitating upward through the tube bundles moves to the crown of the external housing and upward into a collecting dome, where it is withdrawn.

A cellular honeycomb, serving to turn and straighten the flow, was located just downstream of the air separator tubes as shown in Fig. D-10. This honeycomb was formed of standard fiberglass-reinforced plastic corrugated sheets of 0.05 inch thickness with a corrugation of 2.67 x 9/16 inches. These corrugations were of an Alcoa rib form and when properly stacked and aligned yielded cellular honeycomb openings of hexagonal cross section as shown in Fig. F-1 of Appendix F. The corrugated sheets were cut to provide cells of 6-inch length and were riveted together to form large tube bundles somewhat similar to the air separator units shown in Fig. D-12. These bundles were supported by a grid of metal plates somewhat similar to those used to support the air separator as shown in Fig. E-3.

Although the tunnel of Fig. D-10 had existed for some time, it had not been subjected to detailed evaluation. However, since it appeared to be a good design candidate for the proposed new NSRDC facility, it has

undergone evaluation tests under the current study. These tests are treated separately at the end of this appendix.

It should be noted that gravitational separation of gas is not confined to special separators, but can occur in all components of the tunnel loop, with natural collection occurring at all trapped high points in the loop. To minimize detrimental blockage and elastic flow contributions, such points should be fitted for continuous automatic bleed-off of all collected gas.

2. Centrifugal Separators

A centrifugal separator is essentially a settling chamber in which gravitational acceleration, g , is replaced by centrifugal acceleration, V^2/r , by routing the flow spirally around the inside of a cylindrical chamber in order to generate a tangential velocity V acting at a radius r . The spiral path must have a length sufficient to permit the necessary settling out of the design bubble. These devices, commonly known as cyclone separators, have a long history of development and are commercially available for the separation of solids from liquids, solids from gases, liquids from gases, and liquids from liquids. The principle is apparently not exploited commercially for the removal of gases from liquids. Figure D-11 shows typical arrangements for the removal of heavy solids.

With the operating conditions commonly employed, the centrifugal separating force may range from 5 times gravity in very large-diameter, low-resistance cyclones to 2500 times gravity in very small, high-resistance units. The values used are a trade-off between the cost of high capital and space investments and the cost of high operating energy and compact size. The friction loss through commercial cyclones may range from 1 to 20 inlet velocity heads for the usual proportioning of the cyclone and may be as low as about 0.25 for low resistance units. These values, derived from cyclones designed to separate heavy particulate from a light fluid, are not directly applicable to a cyclone designed to separate light particulate from a heavy fluid. However, the complexities of the flow routings would probably be somewhat analogous in the two cases, and substantial head losses might also be expected when air is being separated from water.

While it is conceivable in principle that a centrifugal or cyclone type of air separator could be designed for the removal of air from tunnel water, the following factors make it appear unattractive at the present time:

1. There seems to be no prior art to define the feasibility of this type of device, and proper development would be time-consuming and costly.
2. It is probable that an ultimate design would have a substantial energy head loss.

This type of device has been subjected to separate theoretical study at NSRDC, but at the present time is physically untested. It is not proposed that further consideration be given to a major separator of this form. This decision is based mainly on the fact that the tube type of separator developed at St. Anthony Falls appears to provide a practical and essentially proven alternate solution.

3. Momentum or Impingement Separators

Separators which employ momentum to separate flow elements of differing mass have been developed in limited commercial forms for use in separating solids from fluids [D-11], but there appears to be no prior art for using the principle to remove gas from water.

This method depends on the fact that a body introduced into a flow will deflect the fluid in a certain pattern of streamlines. Heavier particulate carried by the flow will, by reason of its greater inertia, cross the fluid streamlines and tend to move toward the obstructing body, while lighter particulate will be forced away from the body by the pressure gradient. The presence of the body thus serves to separate the particulate from the main flow, and with a suitably placed withdrawal sink, some separation of the differing masses may be accomplished. The prime objection to the method is that effective separation occurs only for that portion of the fluid field which experiences major deformation of streamlines. The deflecting bodies should be relatively closely spaced across the flow field if good separation efficiency is to be achieved. This in turn leads to a large drag or flow head loss. In view of the fact that large energy losses must be involved and that no established prior art in development exists, this approach to the gas separation problem is not recommended.

A somewhat analogous device has recently been subjected to limited physical investigation at NSRDC [D-12]. This consisted of a set of deflecting baffles arranged across the flow with the collection sink formed in the

body wake. The conclusions from this investigation do not encourage the use of the system for gas separation in the new test facility.

It is possible that some separation may be achieved by withdrawing gas from the low-pressure side of the turning vanes if vented cavities exist at these locations. Bubbles would be forced to these regions by the existing pressure gradients between successive vanes.

As discussed in Appendix B, it is common practice in free surface tunnels to employ surface skimming in order to remove the considerable entrained gas that is expected to exist close to the free surface. It is anticipated that skimming of not more than about 5 per cent of the flow at the entrance to the diffuser just downstream of the test section will accomplish significant gas removal.

D. Location of the Air Separator

The location of the air separator in a tunnel loop involves consideration of and compromise between a number of factors. These include velocity, pressure, energy loss, and flow quality.

If it is assumed that a gravity-type air separator is the most effective for use in a water tunnel, this will require that the mean velocity in the separator be no more than 1.5 fps. If such a low-velocity component is to be introduced into the tunnel recirculating loop, it should be introduced where this velocity is most compatible with the flow velocity fixed by other functional requirements of the loop. The tunnel components which have unique velocity requirements are as follows:

1. For a high-speed tunnel the test section speed will be high in accord with the tunnel specifications. In the current facility velocities ranging up to 100 fps are contemplated.
2. To achieve practical size and cost in pump procurement, a pump of maximum specific speed is usually sought. This is in effect a pump in which the mean through-put velocity is designed to be at a maximum. In conventional pump practice the propeller or axial flow form inherently employs these higher specific speeds, and the highest mean flow speed is generally selected in the range from 10 to 20 fps.

3. Effective control of velocity uniformity and turbulence level in the flow entering a test section is usually achieved by providing a refined flow contraction just upstream of the test section. In conventional wind and water tunnel practice it has been found that the area ratio across the contraction must be of the order of 10 if flat velocity profiles are to be obtained at the contraction exit. If turbulence levels are important, even larger ratios must be used. Values of 15 or 20 and higher have been employed.

In view of the fact that major problems of head loss and flow stability occur when flow is slowed or diffused, it appears that installing a low-speed air separator between the test section and the pump is not desirable. This location would require diffusing from a velocity of 100 fps to a velocity of 1 or 2 fps and subsequently accelerating up to the 10 or 20 fps required at the pump. While the energy demands of this extreme diffuser action might be acceptable in a tunnel of small size or speed, for a large, high-speed tunnel the concept should be eliminated from consideration if other options are available.

In the case of the proposed tunnel, locating the low-speed air separator in the low-speed area approaching the contraction appears far more feasible in terms of the modest energy demands imposed.

Location of the air separator just upstream of the test section does, however, impose certain other problems that must be considered and resolved. These include the following:

1. The proposed tunnel is to be designed to operate effectively with test section flows discharging as much as 200 cfm of air. This air must pass through the main diffuser and pump before being extracted at the air separator. An initial concern over the influence of the elastic free air on the stability of flow in the diffuser and pump appears to have been resolved. As discussed separately under diffuser considerations, the work of others indicates that the proposed air load is normally less than that required to produce two-phase instability. As discussed in Appendix G, pump considerations, current experimental tests in the St. Anthony Falls 42-inch tunnel establish that

the proposed air loading does not cause significant pump performance changes.

2. At high gas loadings, and especially under low speed operating conditions, substantial amounts of gas may settle out at high points in the tunnel circuit. Adequate provision must be made for either automatic bleed-off or suction removal to prevent build-up. Removal should, in general, be external to the tunnel and directly to the air separator.
3. Under high speed conditions the pressure drop between the gas separator and the test section may be as much as from 70 psia to 2 psia. Bubbles released by the air separator can thus be expected to expand about twice in diameter. This is not a critical change, but it does have an influence on the bubble spectrum available in the test section.

On the basis of the above considerations it is recommended that the air separator be located immediately upstream of the tunnel contraction as it has been in the previous St. Anthony Falls tunnels shown in Figs. D-9 and D-10.

E. Cross-Sectional Shape of the Air Separator

Because of the very large diameter of the separator housing (≈ 28 ft) and the very large operating pressure (≈ 100 psi) and vacuum that it must retain, a circular cross section appears structurally attractive. While some advantages would result from fabricating the diffuser and separator control elements to fit a square section, these advantages are not considered worth the complications involved in providing structural stability for a square pressure container.

F. Air Loading Tests in the St. Anthony Falls 42-Inch Tunnel

The ability of the separator to remove entrained gas in large quantities was examined experimentally. Gas was injected at two locations upstream of the separator. The first injection location was just downstream of the pump at station VI in Fig. D-10. The second location was some distance upstream of the pump at station V in Fig. D-10. Thus the effects of the entrained gas on the pump could be evaluated.

The results of this study showed that the average usable velocity in the separator seemed to be of the order of 1.3 fps. It will be shown in Appendix E, however, that the velocity profile entering the separator was not ideally flat at the time of the test and that therefore, higher velocities existed than can ultimately be provided. Under these conditions a good portion of the separator was experiencing velocities of about 1.4 times the average velocity, or about 1.8 fps. It is thought that a mean separator velocity of 1.5 fps would be usable provided that it was experiencing an approximately flat inflow velocity profile. These results are shown graphically in Fig. D-13.

The upper velocity limit is controlled more by the characteristics of the separator tubes themselves than by simply being overloaded with gas. Under maximum gas loading, considerable gas is being separated and removed at the maximum velocities.

Evidently, the shear in the larger gas pockets in the cusp zone of the separator tubes begins to overcome the gravitational force and tends to sweep the larger bubbles out the downstream end of the separator tubes. This effect begins to occur in the neighborhood of the dashed line separating the zone of excellent separation from the usable zone in Fig. D-13 and worsens progressively as the velocity increases.

It is probable that additional observations and minor adjustment of the tubes will substantially improve this condition. Such tests are recommended for a future model study.

G. Energy Loss Studies in the St. Anthony Falls 42-Inch Tunnel

In order to determine the energy losses contributed by the St. Anthony Falls type air separator, evaluation tests were made in the 42-inch tunnel. In this instance the 90° elbow, the short diffuser for the separator, the separator, and the honeycomb flow straightener were considered as a unit. The measurement stations are located at numerals I and III in Fig. D-10.

According to the Bernoulli energy equation for one-dimensional flow,

$$\frac{P_I}{\gamma} + \alpha_I \frac{\bar{V}_I^2}{2g} + Z_I - \frac{P_{III}}{\gamma} - \alpha_{III} \frac{\bar{V}_{III}^2}{2g} - Z_{III} = H_{\text{loss}}$$

where P = pressure
 γ = specific weight of water

$$\alpha = \frac{\int_A u^3 dA}{A \bar{V}^3}$$

where u = local axial velocity
 A = cross-sectional area
 \bar{V} = average velocity

$$Z = \text{elevation of measurement location}$$

$$H_{\text{loss}} = \text{loss of head between I and III} = K_n \frac{\bar{V}_{\text{III}}^2}{2g}$$

The equation reduces to

$$\alpha_I \left(\frac{A_{\text{III}}}{A_I} \right)^2 - \alpha_{\text{III}} - \frac{2gA_{\text{III}}^2}{Q^2} \Delta H = K_n$$

$$\Delta H = (P_{\text{III}} - P_I)/\gamma + (Z_{\text{III}} - Z_I)$$

where Q = quantity of flow

The α coefficients were determined by measuring and integrating the velocity profiles. This was accomplished by inserting a pitot cylinder at location I and a remote-reading small propeller meter at location III. These instruments were positioned with their axes parallel to the tunnel axis. The instrument traverse lines for each location were two mutually perpendicular diameters of the cross section. The diameters used were at about 45° with the horizontal. Four flows were investigated, and the results are presented in Table D-1.

Table D-1

<u>Q, cfs</u>	<u>α_I</u>	<u>α_{III}</u>	<u>$\Delta H, \text{ ft}$</u>	<u>K_n</u>
8.1	1.0	1.399	0.0046	50.75
8.78	1.065	1.360	0.0056	55.11
11.58	1.0	1.341	0.0104	50.61
18.5	1.091	1.257	0.0268	<u>56.25</u>
Average =				53.18

The velocity profiles for the two locations, the four discharges, and two traverse lines are presented in Figs. D-14 and D-15. The propeller meter has characteristics that enable it to detect large-scale turbulence, and little large-scale turbulence was detected at location III. The existence of small-scale turbulence is discussed in Appendix F. The propeller meter also has an angular response approximating a cosine function, and therefore the profile of Fig. D-15 exhibits the axial component only. The peaked distribution shows the effect of the contraction located immediately downstream of location III.

H. Air Separator Recommendations

On the basis of the foregoing background and tests it is recommended that an air separator unit patterned after the St. Anthony Falls unit shown in Fig. D-10 be adopted for preliminary design considerations for the proposed NSRDC facility. Since the flow tube and honeycomb elements which would be recommended for the prototype would be of the same dimensional size and would operate with the same absolute velocities used in the St. Anthony Falls tunnel, there is no reason to believe that scale effects would be involved in data use.

REFERENCES

- [D-1] Ripken, John F. and Olson, Reuben M., A Study of the Influence of Gas Nuclei on Cavitation Scale Effects in Water Tunnel Tests, Project Report No. 58, St. Anthony Falls Hydraulic Laboratory, University of Minnesota, 1958.
- [D-2] Ripken, John F. and Killen, John M., A Study of the Influence of Gas Nuclei on Scale Effects and Acoustic Noise for Incipient Cavitation in a Water Tunnel, Technical Paper No. 27-B, St. Anthony Falls Hydraulic Laboratory, University of Minnesota, 1959.
- [D-3] Killen, John M. and Ripken, John F., A Water Tunnel Air Content Meter, Project Report No. 70, St. Anthony Falls Hydraulic Laboratory, University of Minnesota, 1964.
- [D-4] Schiebe, Frank R., The Influence of Gas Nuclei Size Distribution on Transient Cavitation near Inception, Project Report No. 107, St. Anthony Falls Hydraulic Laboratory, University of Minnesota, 1969.
- [D-5] O'Neill, J. P., The Hydrodynamics of the Free Surface Water Tunnel, Report No. N-65, Hydrodynamics Laboratory, California Institute of Technology, 1949.

- [D-6] Pekeris, C. L., The Rate of Rise and Diffusion of Air Bubbles in Water, OSRD 976, NDRC C4-sr20-326, CUDWR-PAG, October 1942.
- [D-7] Haberman, W. L. and Morton, R. K., An Experimental Investigation of the Drag and Shape of Air Bubbles Rising in Various Liquids, Report 802, David Taylor Model Basin, September 1953.
- [D-8] Johnson, V. E. and Goodman, A., "The Hydronautics Variable-Pressure Free-Surface High-Speed Channel," Cavitation Research Facilities and Techniques, American Society of Mechanical Engineers, 1964.
- [D-9] Boes, C. and Bade, P., "Grober Umlauftank fur Hydrodynamik,-Akustic- und Kavitationsuntersuchen," Schiff and Haffen, Heft 3, 1970, 22 Jahrgang.
- [D-10] Brownell, W. F., Jr., Report on Foreign Travel, November 15, 1971.
- [D-11] Perry, J. H. (editor), Chemical Engineer's Handbook, McGraw-Hill, 1963.
- [D-12] Cieslowski, D. and Rood, E., "Evaluation of Wedge-Induced Vortex Entrainment and Removal of Bubbles in a Water Tunnel," an informal letter report of NSRDC, February 25, 1972.

BEST AVAILABLE COPY

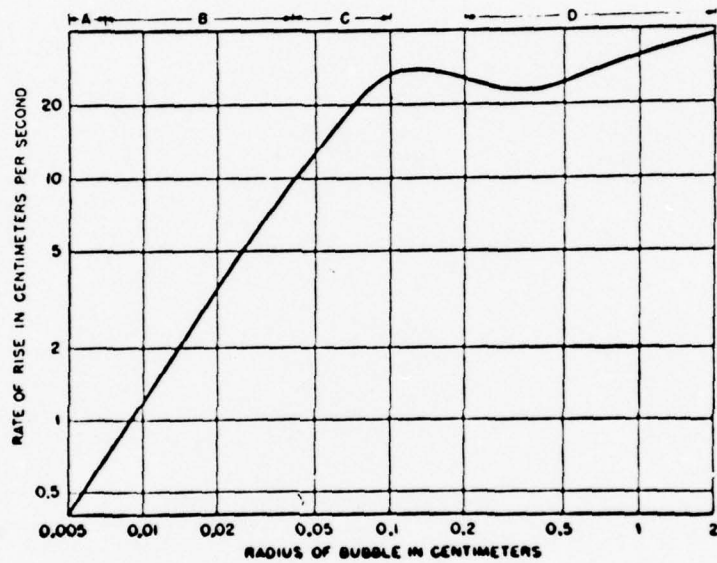

Fig. D-1 - The Terminal Rate of Rise of Air Bubbles in Water (from Ref. [D-6])

BEST AVAILABLE COPY

Max. $V = 40$ fps

Max. $Q = 80$ cfs

Avail HP = 1000

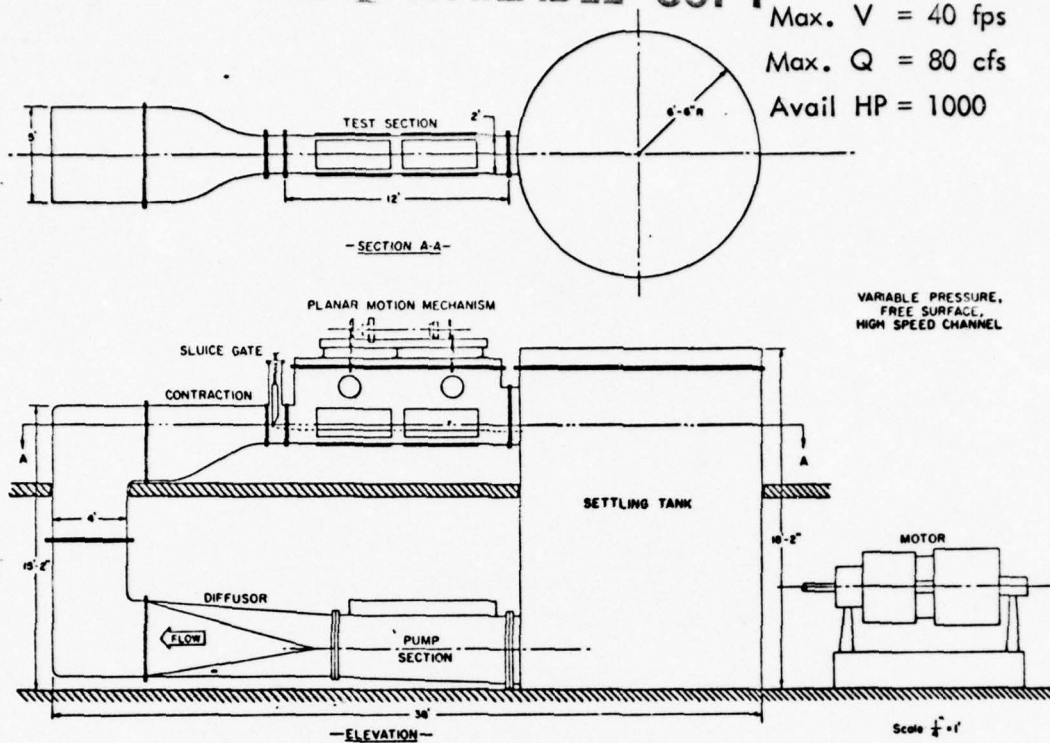

Fig. D-2 - The Hydronautics Variable-Pressure, Free Surface Test Facility with Vertical Gravity Air Separator (from Ref. [D-8])

Max. $V = 37$ fps
 Max. $Q = 2170$ cfs
 Avail HP = 6000

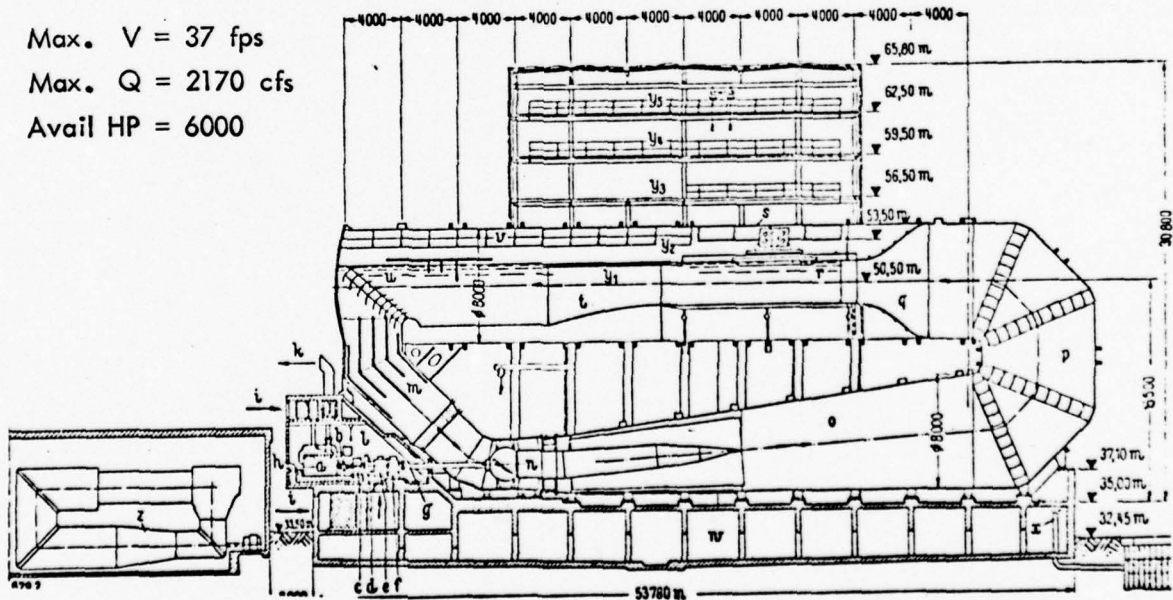
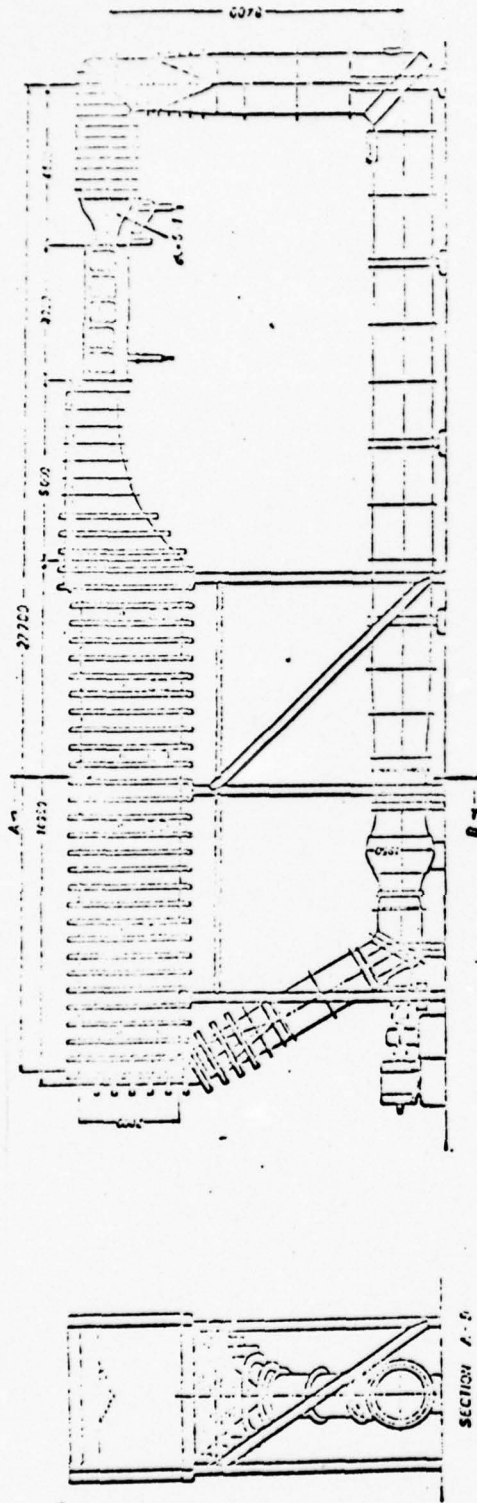

Fig. D-3 - The Variable-Pressure, Free Surface Test Facility of VWS in West Berlin with Horizontal Gravity Air Separator (from Ref. [D-9])



DC MOTOR 750 (MAX. 600) [HP] AT 15-1500-1600 [RPM] (INVERTOR CONTR) MAX VELOCITY IN TEST SECTION 18 [m/s] FOR DEPTH 600 [mm]
 GEARBOX REDUCTION RATIO 56:1
 GEARED FLOW PUMP D=1,250 [m]
 WATER VOLUME 250 [m³]
 MIN. CAVIT. NUMBER AT HALF DEPTH G=0.07 FOR DEPTH 600 [mm]
 G=0.05 FOR DEPTH 300 [mm]

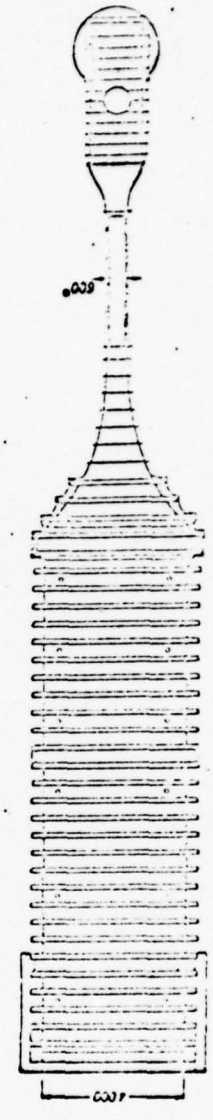
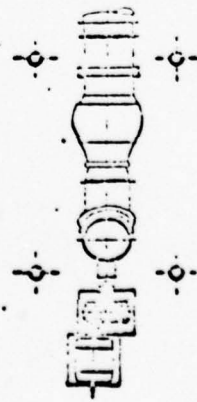

Fig. D-4 - The Variable-Pressure, Free Surface Test Facility at the Technical University of West Berlin with Horizontal Gravity Air Separator (from Ref. [D-10])

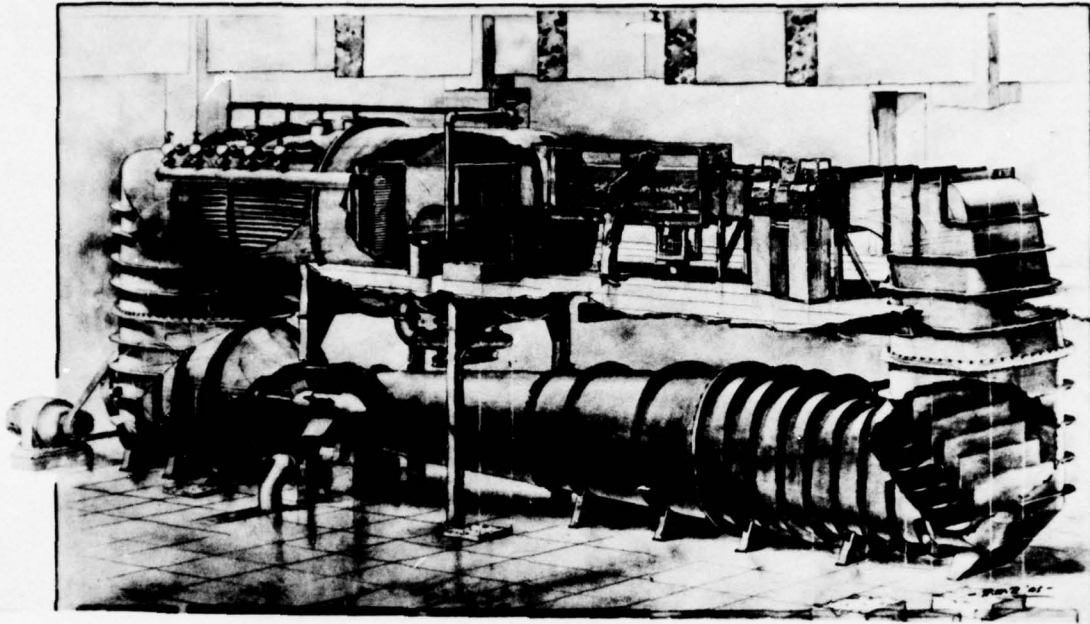

Fig. D-5 - The Free-Surface Test Facility at the California Institute of Technology with Tray-Type Gravity Air Separator (from Ref. [D-5])

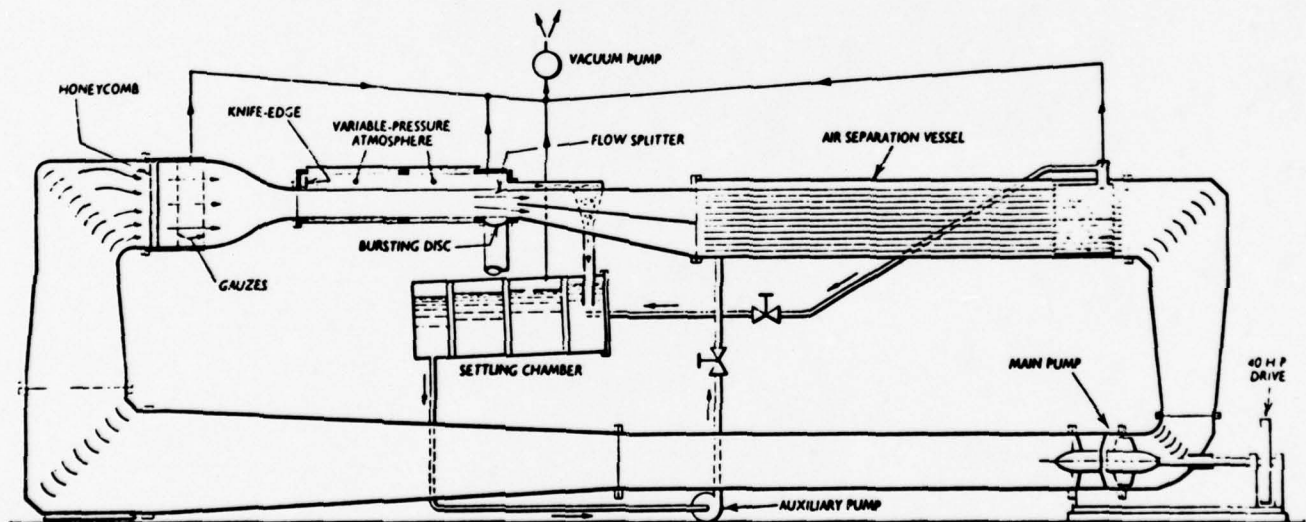

Fig. D-6 - The Variable-Pressure, Free Surface Test Facility at the University of Leeds with Tray-Type Air Separator (from Ref. [D-10])

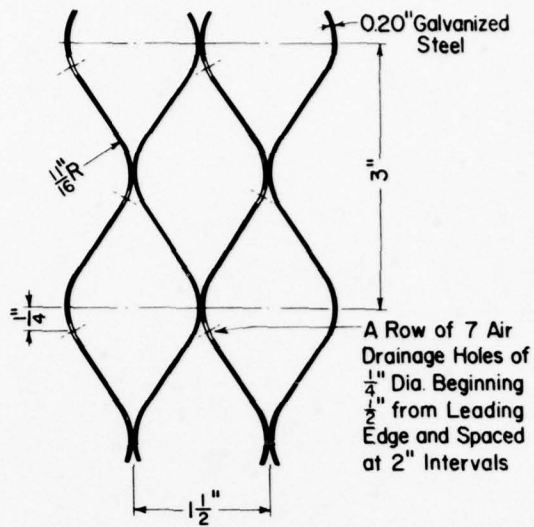

Fig. D-7 - Configuration of Air Separator Tube Employed in the 6-Inch SAF Tunnel

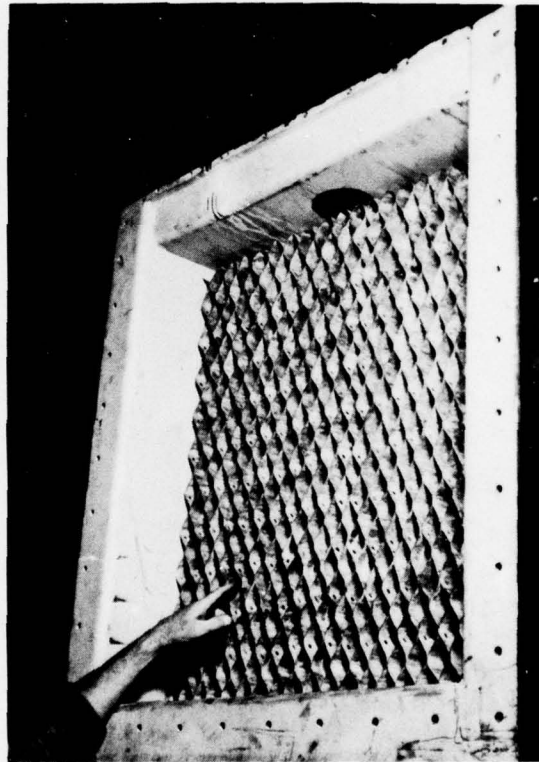

Fig. D-8 - General Arrangement of Air Separator Tubes in the 6-Inch SAF Tunnel (viewed from upstream)

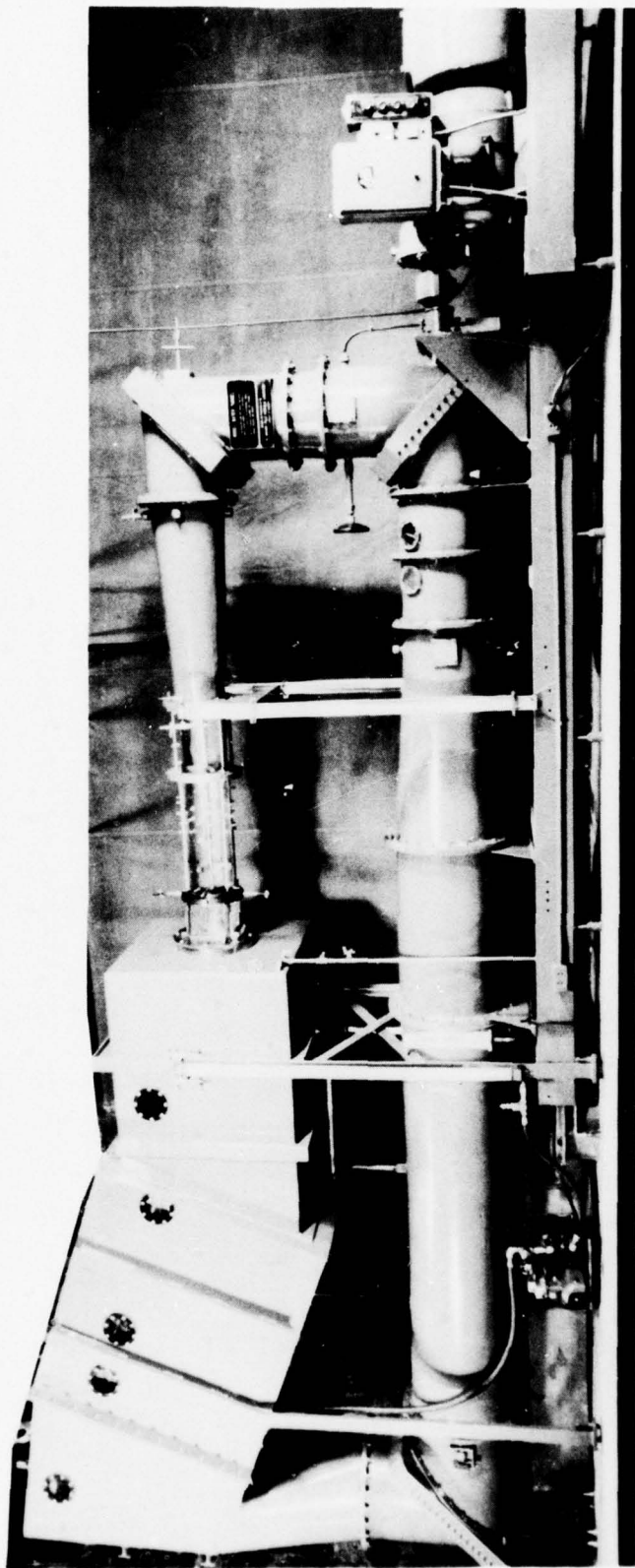

Fig. D-9 - The 6-Inch SAF Water Tunnel with Tube-Type Air Separator at Left

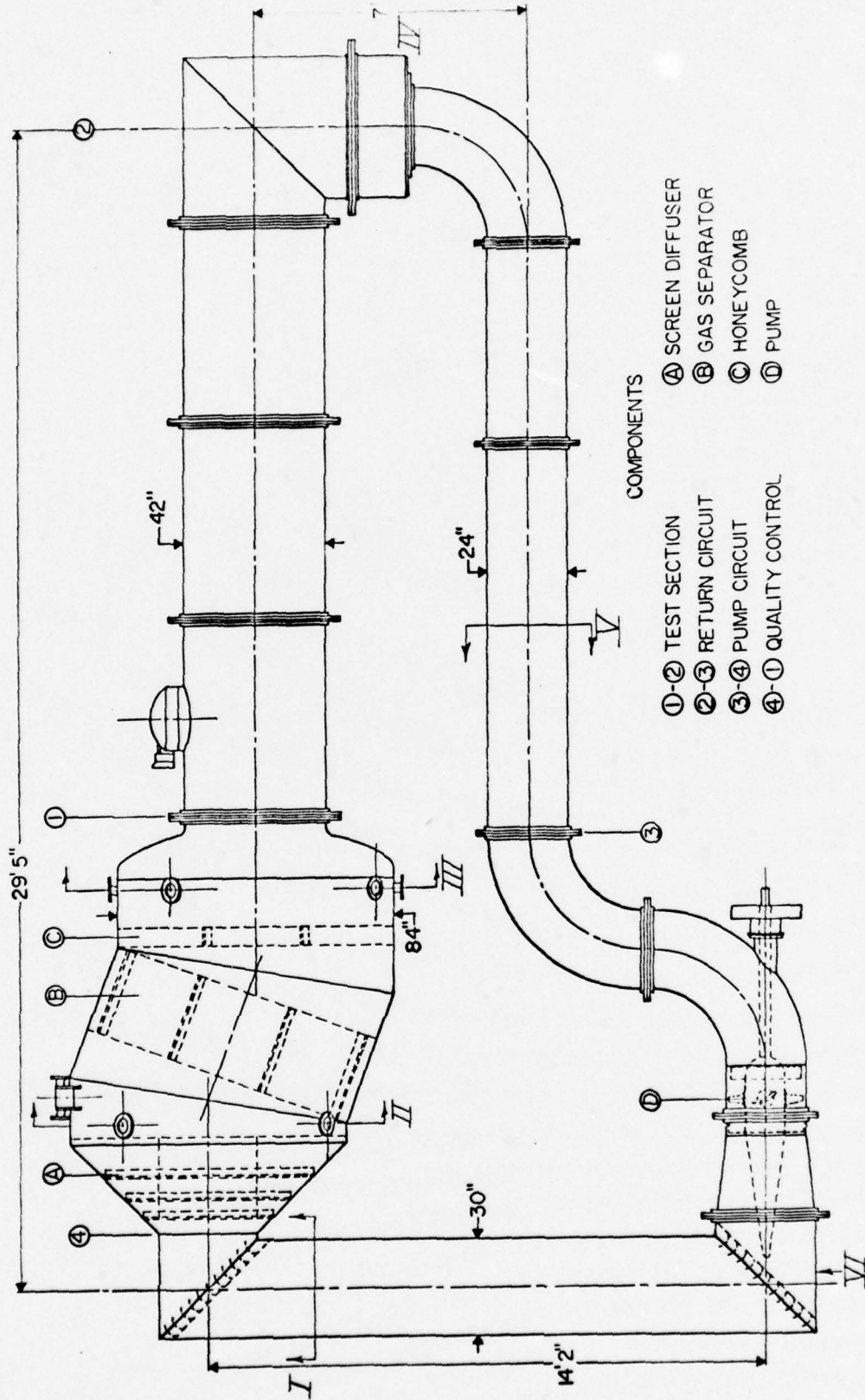
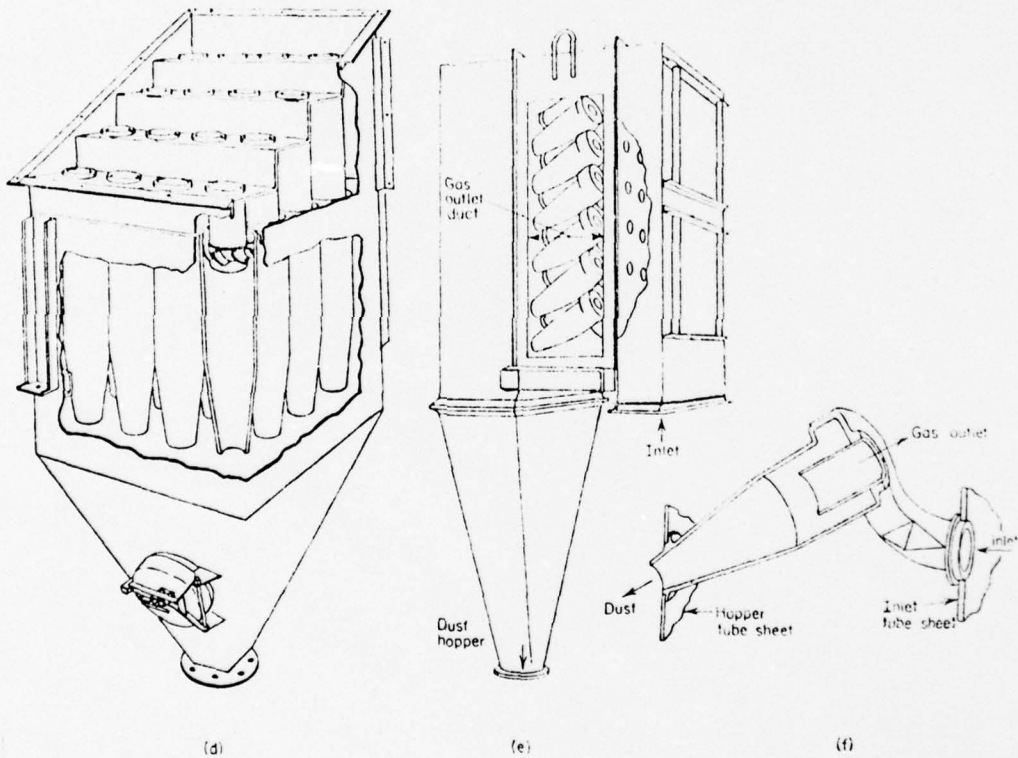
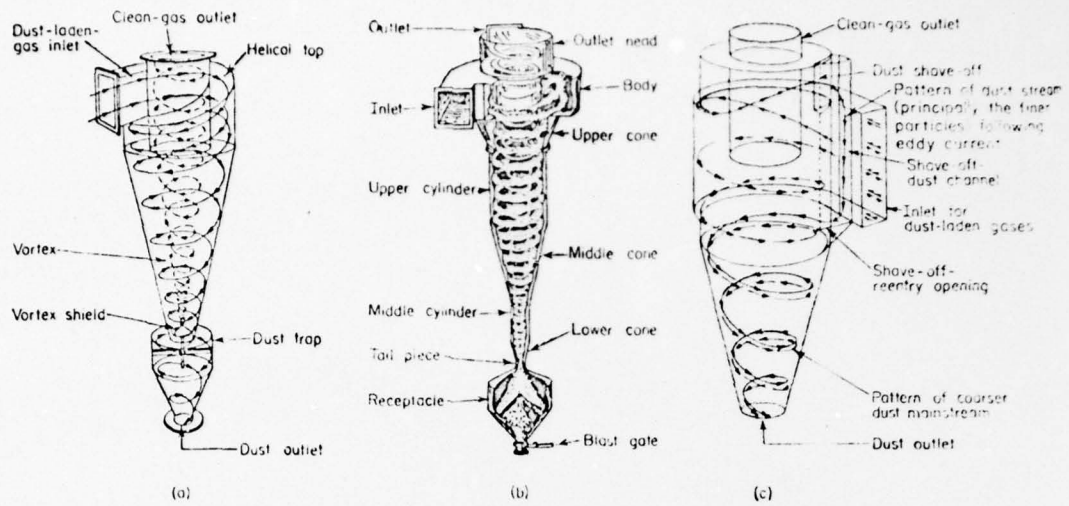

Fig. D-10 - The 42-Inch SAF Water Tunnel with Tube-Type Air Separator



Typical commercial cyclones. (a) Duclone collector. (*Ducon Company*.) (b) Sirocco type D collector. (*American Blower Co.*) (c) Van Tongeren cyclone. (*Bull Engineering Co.*) (d) Multiclone collector. (*Western Precipitation Corp.*) (e) Dustex miniature collector assembly. (*Dustex Corp.*) (f) Cutaway of the Dustex cyclone tube.

Fig. D-11 - Typical Commercial Cyclone Separators (from Ref. [D-11])

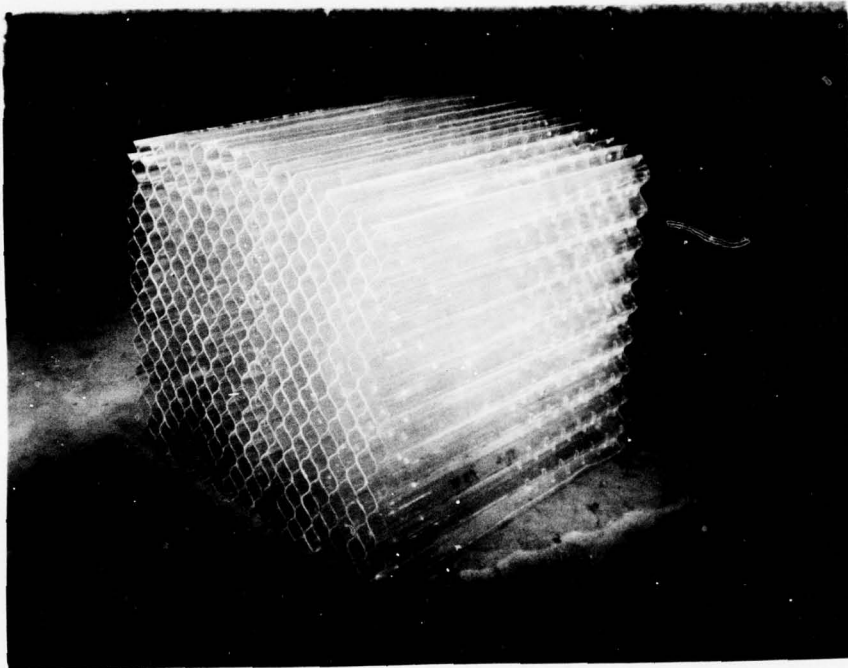

Fig. D-12 - An Air Separator Tube Bundle as used in the SAF 42-Inch Tunnel

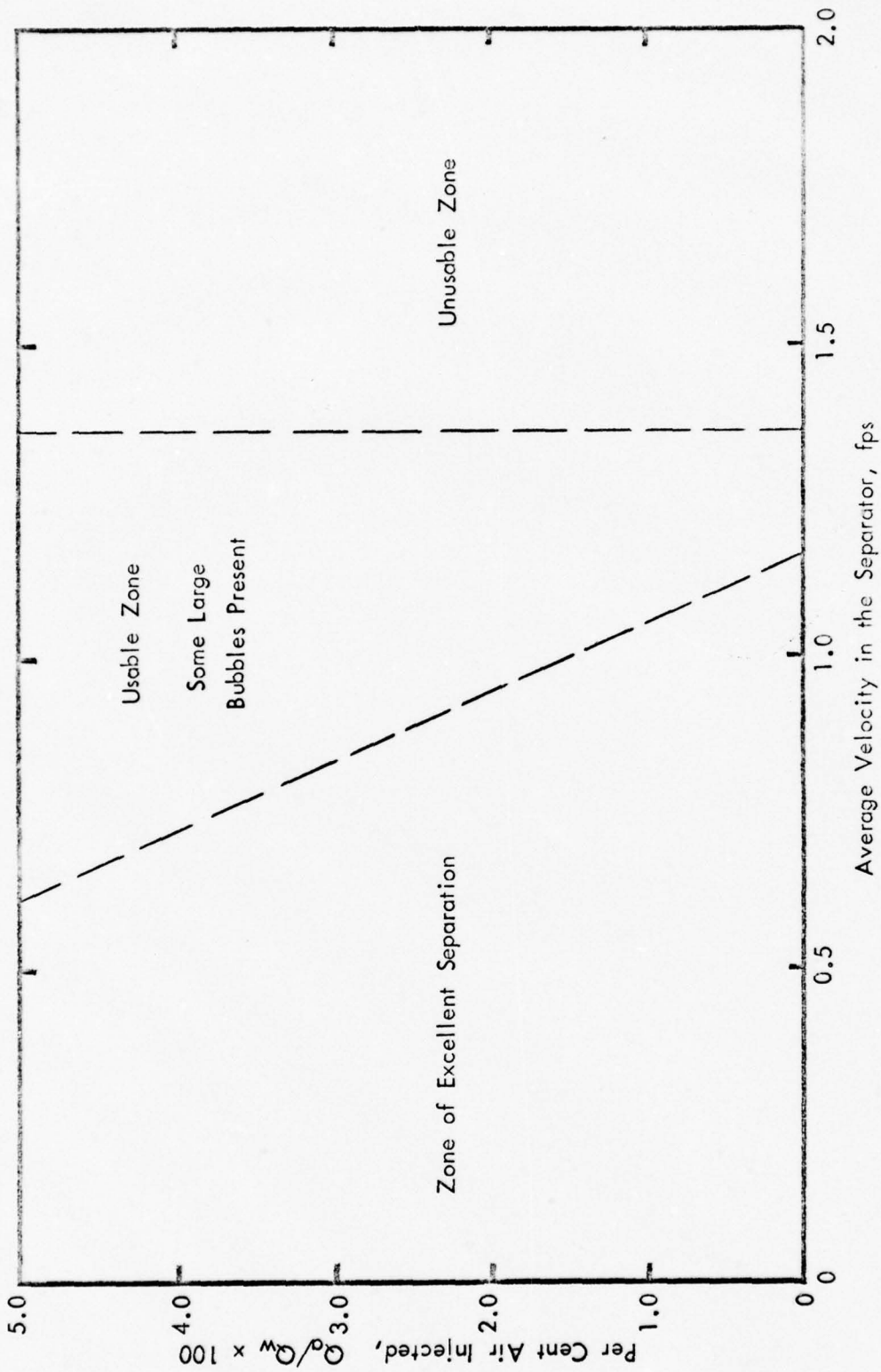

Fig. D-13 - Air Separator Characteristics for the SAF 42-Inch Water Tunnel
 (Test velocities shown are maladjusted as per Fig. D-15 and are subject to
 increase with future adjustments - see text page D-15.)

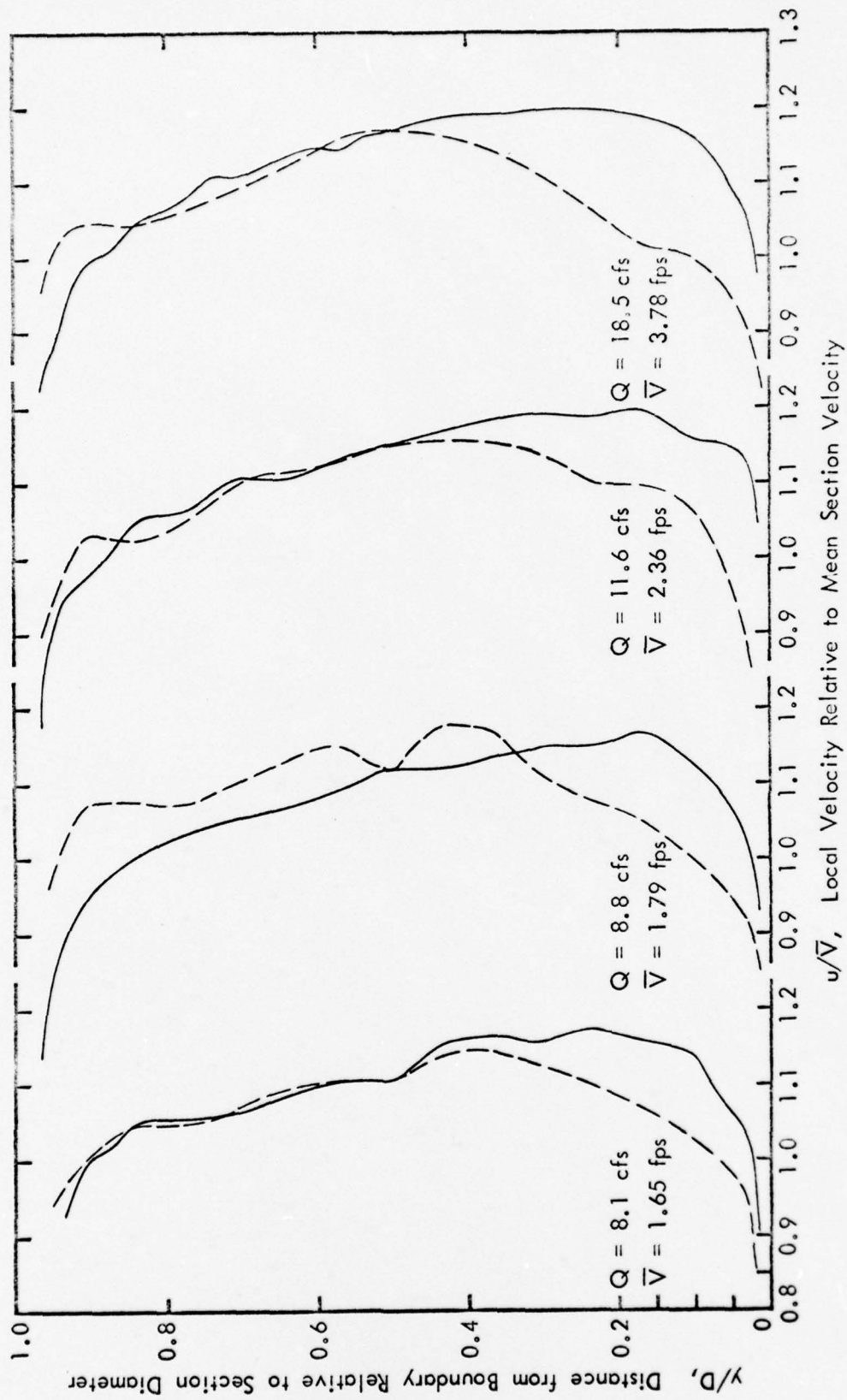

Fig. D-14 - Velocity Profiles at Location 1 in the SAF 42-Inch Tunnel

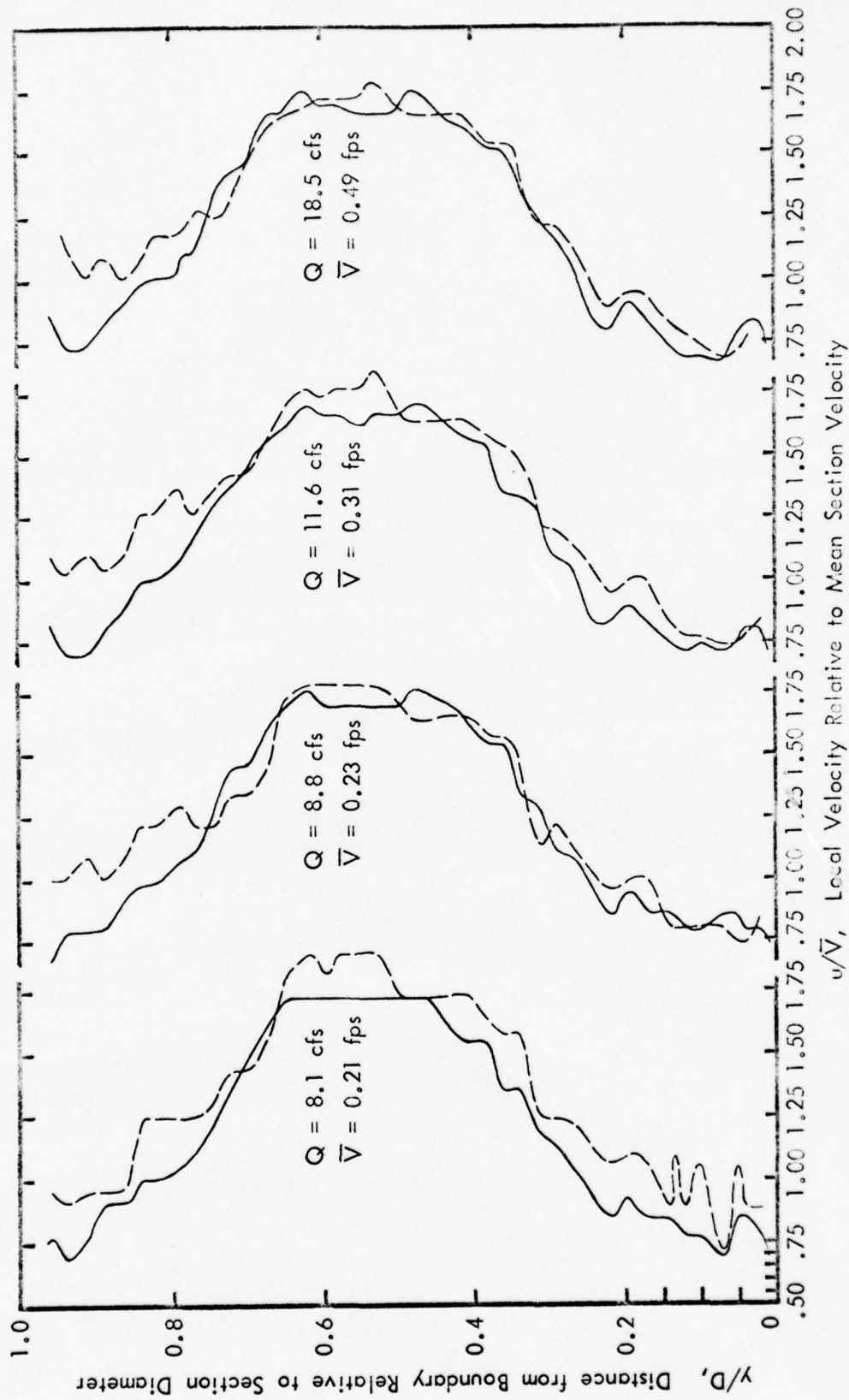

Fig. D-15 - Velocity Profiles at Location III in the SAF 42-Inch Tunnel

Appendix E

THE DIFFUSER FOR THE GAS SEPARATOR

In Appendix D a rationale and experimental tests led to the recommendation of a tube-type gravity gas separator for inclusion in the proposed tunnel flow loop. It was established that proper performance of this separator would require that the flow entering the separator have a mean velocity of not more than about 1.5 fps and that the velocity profile be essentially flat. It was further noted in Appendix D that the velocity in the tunnel approaching the separator is to some extent controlled by the velocity requirements through the pump annulus and that a conventional design value for this would range from 10 to 20 fps. In most pumps a short diffuser is included as part of the pump, and the mean velocity at the end of the pump will be appreciably reduced. Since a number of design and cost factors will be involved in the eventual pump procurement for a new facility, it is not possible to firmly establish pump dimensions and velocities at this time. However, some insight into these values can be derived from the pump of the existing 36-inch NSRDC tunnel. In this unit the rated pump conditions produce an exit pump velocity of about 14 fps. If it is assumed that a similar value might eventually evolve for the design of a new facility, this would require flow expansion or diffuser action from a velocity of 14 fps to a velocity of 1.5 fps. If the design discharge of the new facility is tentatively taken as 900 cfs, for circular cross sections this would require a diameter of about 9 ft at the pump exit and about 28 ft at the separator entrance.

Where and how the necessary diffuser action should be applied is the question. Since no critical or significant flow problems are anticipated for the flow between the pump and the separator, selection of velocities or sizes is principally a trade-off between the cost factors involved in using a larger or smaller pipe cross section. If all the diffuser action is concentrated in a single unit just upstream of the separator, the connecting pipe and two elbows will be made of minimum size to accommodate the pump discharge velocity of $V_{\max} = 14$ fps. While this system could be made workable, a significant saving in pump head can be achieved by electing a somewhat lower velocity. This can be readily achieved by applying additional diffuser action immediately after the pump. It is recommended that a diffuser of about 8° included angle be introduced immediately after the pump and that its

length be made such that the velocity will be reduced to about 10 fps. This velocity would then be maintained up to the entrance of the separator diffuser.

Under the foregoing conditions the separator diffuser would require an area expansion ratio of about 7 to achieve a separator inlet velocity of 1.5 fps. This is a large ratio for the prior art of simple conical diffusions and would moreover require a very long and costly structure if the usual low included angles of 5° to 10° were used to achieve good energy recovery. As an alternative, one could elect to provide a very rapid expansion with a compact, low-cost structure and suffer the consequences in terms of energy loss. In view of the fact that the entering velocity is $V_{\max} \approx 10$ fps or an energy head of about 1.5 ft, the cost of losing this kinetic energy head is not serious if an adequate and simple short diffuser can be developed.

When this same problem was studied in 1957 relative to installing a tube-type air separator in the 6-inch tunnel at St. Anthony Falls, the solution evolved was as shown in Figs. D-9 and E-1. The diffuser area ratio was 4, and diffusion was combined with flow turning as shown in Fig. E-1. Due to maldistribution at the elbow entrance and some separation in the diffuser passages, the velocity downstream was quite non-uniform and asymmetrical. Resistance screening added to the vane exit provided a fair correction and was used for many years satisfactorily, but without detailed evaluation. During the present program the screen was removed and the quality in terms of turbulence intensity was assessed. It was found that intensities through the central part of the flow ranged from 25 to 50 per cent, while near the walls intensities of several hundred per cent were found in separation eddies.

When this same problem was studied in 1966 relative to installing a tube-type separator in a new 42-inch tunnel at St. Anthony Falls, the solution elected was as shown in Fig. D-10. This tunnel involved a diffuser area expansion ratio of about 8. The turning vane diffuser employed in the 6-inch tunnel was reviewed at that time, but because of the substantial increase in expansion ratio, the turning vane diffuser was bypassed in favor of a rapid expansion cone fitted with a series of resistance screens. This design was based on a wind tunnel diffuser study by Schubauer and Spangenberg [E-1] and screen studies by Baines and Peterson [E-2]. In the installation of Fig. D-10 the diffuser consists mainly of a conical pressure housing

of 90° included angle fitted with a series of four perforated resistance plates. These plates were of 0.035 inch thick stainless steel sheet perforated with holes of 0.25 inch diameter staggered and on 0.3175 inch centers to provide an opening of 58 per cent. The perforated plates were assembled in weld fabricated units as shown in Fig. E-2, and these units were bolted to anchors welded to the conical housing wall as shown in Fig. E-3.

Recent tests on the assembly of Fig. D-10 have employed pitot-tube and propeller meter velocity traverses upstream and downstream of the diffuser to establish flow quality for this tunnel component. The profiles resulting from the traverses at location I of Fig. D-10 as shown in Fig. D-14 of Appendix D approximate the conditions entering the diffuser.

The results of the velocity traverses taken approximately 3 inches downstream of the fourth or last perforated plate, location II in Fig. D-10, are shown in Fig. E-4. These profiles indicate a deficiency of resistance in the central portion of the diffuser. It is believed that future adjustments can be made readily in this resistance in order to unify the flow profile. The irregularities in the profiles are partially due to the fact that the profiles were taken across the wakes of some of the structural members supporting the resistance screens. Excessive turbulence was noted in the regions near the walls.

The described short diffuser has performed essentially in accord with its design, and the general design and method of construction are believed adequate to meet the needs of the proposed NSRDC facility. In view of the fact that the proposed prototype is only about four times the size of the St. Anthony Falls tunnel which is serving as a model and the fact that most of the control surfaces involved in the diffuser mechanics have sharp-edged boundary configurations, scale effects are not considered critical. Preliminary design calculations for the proposed facility indicate that a series of four screens of the same sizing employed in the St. Anthony Falls tunnel should suffice for diffusion. The general configuration of this type of design, when applied to the NSRDC operating conditions, leads to the preliminary offering shown in Fig. 1.

It is recommended that additional experimental studies be conducted on the St. Anthony Falls model to establish a better exit velocity distribution.

The energy losses for this element of the tunnel were not evaluated separately, but are included with the losses of the preceding elbow and the following air separator.

REFERENCES

- [E-1] Schubauer, G. B. and Spangenberg, W. G., Effect of Screens in Wide Angle Diffusers, NACA Technical Note No. 1610, 1949.
- [E-2] Baines, W. D. and Peterson, E. G., "An Investigation of Flow through Screens," Transactions of the ASME, July 1951.

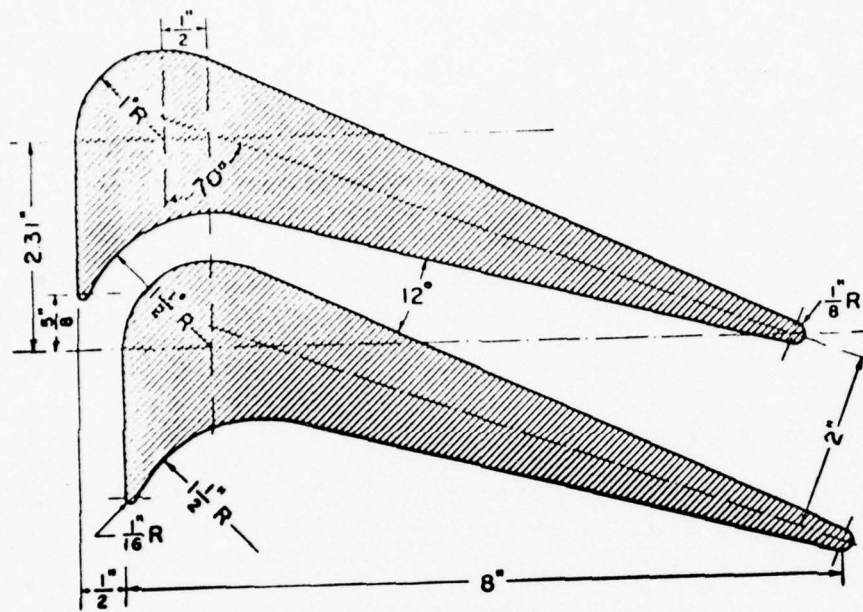

Vane Detail

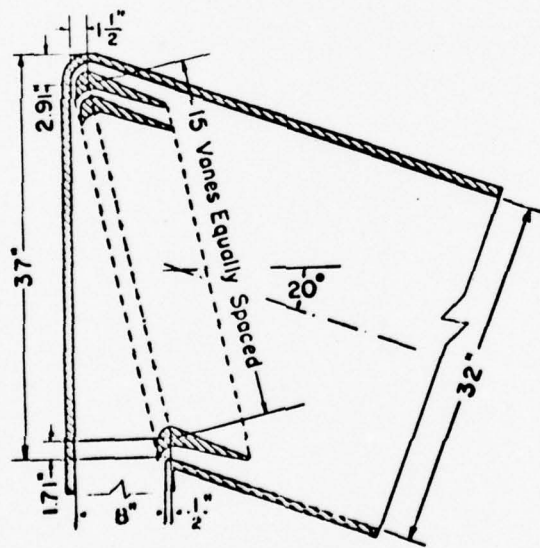

Elbow Assembly

Fig. E-1 - Arrangement of the Two-Dimensional Combined Turning Vane and Flow Diffuser Used in the 6-Inch SAF Tunnel

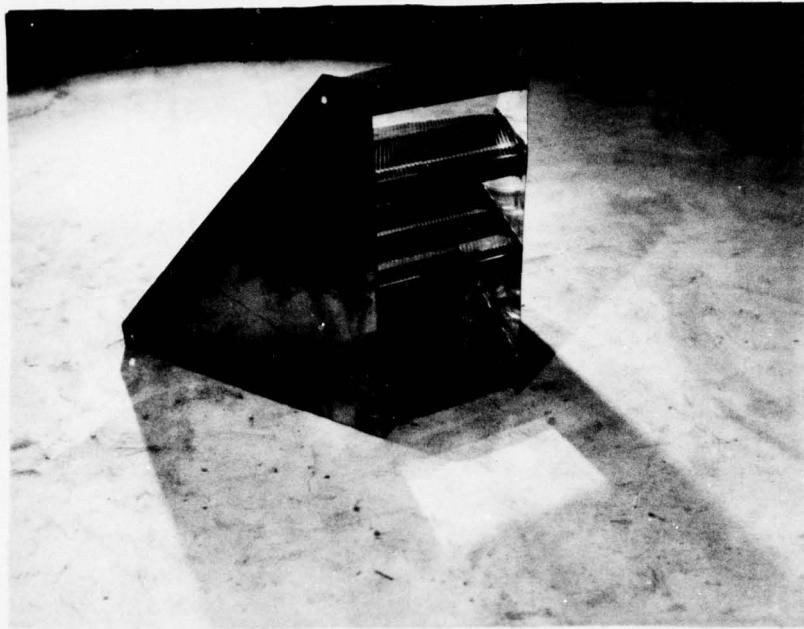

(a) Four stage peripheral element (1 of 8)



(b) Single stage center element (4 units thus)

Fig. E-2 - Prefabricated Elements of the Resistance Members
of the Separator Diffuser of the SAF 42-Inch Tunnel

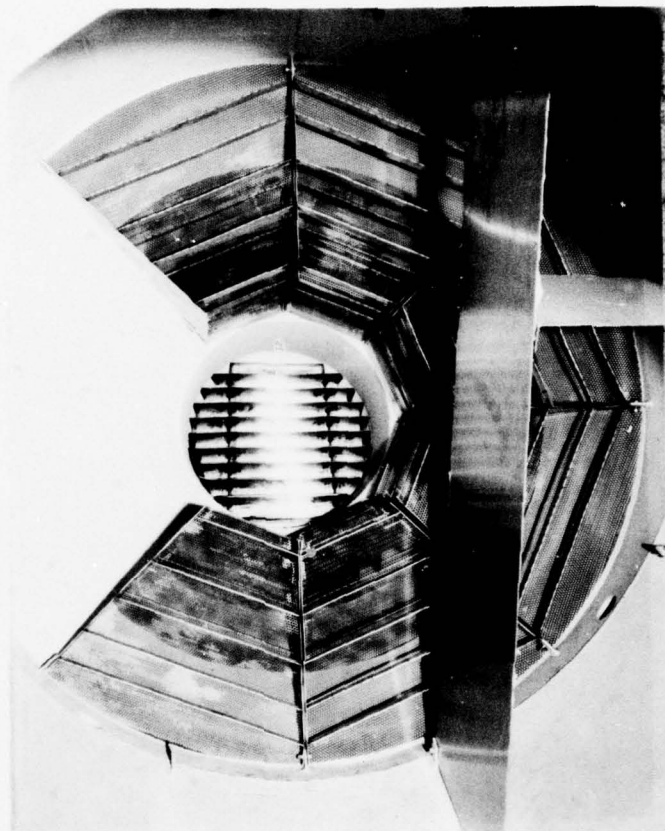

Fig. E-3 - Partial Assembly of the Resistance Members of the Separator Diffuser of the SAF 42-Inch Tunnel (view looking upstream with separator support plates shown in right foreground)

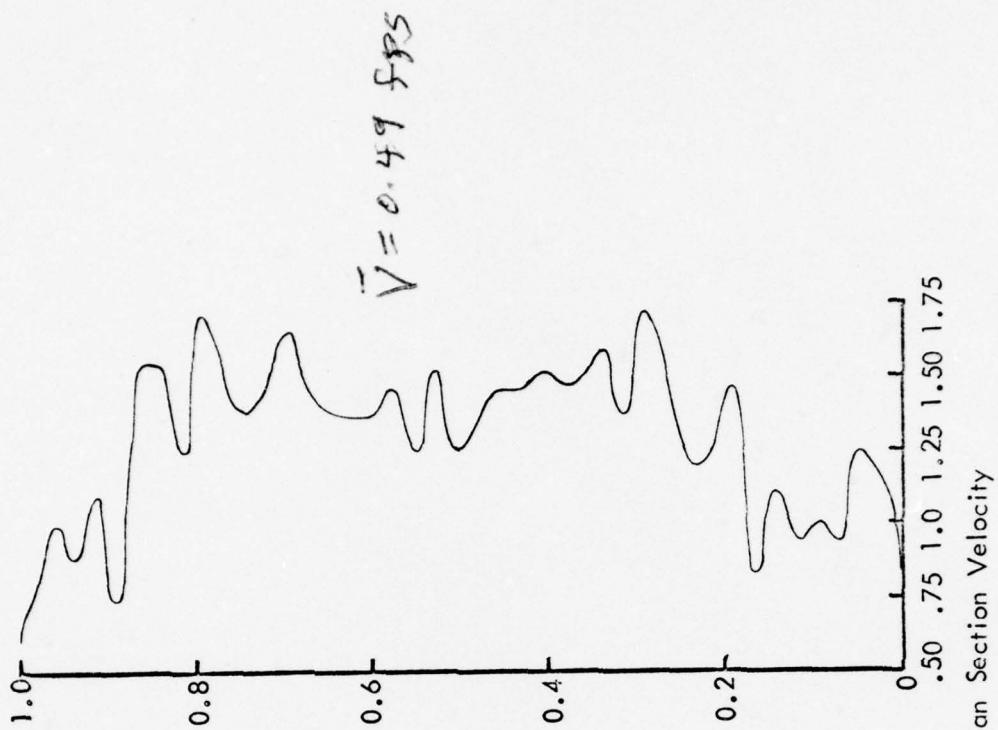
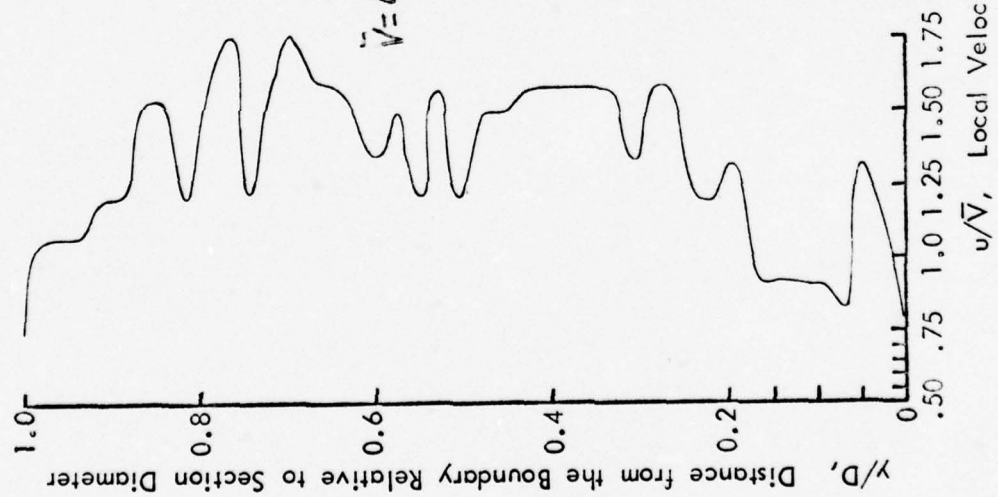

Fig. E-4 - Velocity Profiles at Location II in the SAF 42-Inch Tunnel

Appendix F

THE CONTRACTION AND TEST SECTION ENTRANCE

The primary purpose of the contraction is to provide a high quality flow for the test section. The effect of accelerating the flow contributes to minimizing spatial and time variations of the velocity in the test stream. Furthermore, the large cross-sectional area preceding the test section permits the use of larger components in other parts of the tunnel circuit, thereby reducing the total head loss.

The history of wind and water tunnel design has indicated that contraction ratios of about 6 to 15 are in common use. For axisymmetric, circular contractions it has been shown [F-1] that for area ratios greater than 7, the maximum variation of the exit velocity is less than one per cent over about 85 per cent of the area of the flow stream. Although flow quality tends to improve with large area contraction ratios, small ratios are desired to reduce the size and cost of the contraction.

In order to obtain a better understanding of the possibly critical effect of the contraction area ratio on the stability of a free surface flow, limited tests were recently undertaken in which flow was discharged from various sized sharp-edged orifices to create a free jet. These plane orifices were installed at the end of a long length of 12 in. dia. pipe. Contraction area ratios varied from 27 to 100. A flow straightener constructed of the same material as was used in the separator of the St. Anthony Falls 42-inch tunnel was placed 3 ft upstream of the orifice. This straightener is shown in Fig. F-1. Flow discharges were selected to provide approximately the same absolute velocity in the 12 in. pipe as in the actual air separator.

Jet velocities ranged from 50 to 100 fps, and the character of the jet was observed visually using a repetitive strobe light at several locations along a 20 ft trajectory. High speed still photographs were also taken at various distances downstream of the orifice plane. In conjunction with these tests the turbulence level was also measured in the 12 in. pipe 1 ft downstream of the flow straightener in an attempt to relate the upstream turbulence level to the breakup of the jet surface. Turbulence was measured with a quartz-coated hot film cylindrical sensor of 0.006 in. diameter for pipe velocities from 0.5 to 2 fps. It was found that the longitudinal component

of turbulence intensity was fairly uniform across a given diameter and that the magnitude was on the order of 3 to 5 per cent.

The pilot studies substantiated that a large contraction ratio was beneficial in the production of jets with a high quality free surface near the orifice plane. At a relatively short distance from the orifice the glassy smooth surface changed to a rippled pattern which increased in magnitude further along the trajectory. Considerable spray surrounded the jet at the larger reaches. The high speed photographs were carefully examined in an attempt to quantify the character of the jet surface. At various distances downstream of the orifice plane, estimates were made of the average maximum and minimum diameters as well as of the average diameter of the jet. The results are shown in Fig. F-2 for various contraction or area ratios for a constant jet velocity of 100 fps. As the pipe diameter was fixed upstream of the orifice, a decrease in orifice diameter resulted in an increase in contraction ratio. Δd is the difference between the maximum and minimum diameters, d is the average local diameter, x is the distance downstream from the orifice plane, and D is the orifice diameter. The values plotted at $\Delta d/d = 0$ represent a glassy smooth surface on the jet. As the area ratio decreases, it can be seen that the length of the glassy surface also decreases. The effect of the area ratio persists for some distance downstream, with the larger area ratios providing a relatively smoother jet. At x/D values greater than about 60, the effect of area ratio on relative roughness appears to be minor, and quite possibly the influence of air shear becomes the dominating factor. The limited data and the inherent difficulty in determining the surface roughness of the jet dictate that caution must be exercised in extrapolating the data to other flow situations. However, the general trends shown in Fig. F-2 appear reasonable.

To complete the studies, a commercial nozzle used in fire fighting was attached to the pipe. This long nozzle terminated with a diameter of 1.25 inches. In a comparison of the resulting jet with that obtained from a similar sized orifice generated jet, the glassy smooth surface associated with the orifice jets near the exit was not observed. The boundary layer developed in the long nozzle contributed to excessive disturbance of the jet surface immediately after discharge. This observation led to the conclusion that the contraction should be as short as possible and that the test section free surface should be created by a sharp edge at the contraction exit.

In the selection of a suitable contraction, several requirements should be satisfied. For a contraction preceded by a parallel walled section, an adverse pressure gradient normally exists on the boundary near the entrance to the contraction. The possibility of flow separation associated with the pressure rise should be minimized for optimum flow quality. To reduce the magnitude of the pressure gradient, rather gradual area changes and thus long contractions are required.

In the proposed tunnel configuration, the transition from the circular air separator to the essentially square test section takes place in the contraction. It is intended to provide large fillets in the corners of the square section to minimize axial corner vortices. Some precedence for this type of transition has been established in a recent tunnel design described in Refs. [F-2] and [F-3]. The contraction was divided into two elements: a gradually contracting circular section of horizontal axis that terminated in a vertical plane and the shape transition to the essentially square section proceeding downstream from the vertical plane to the test section. In this the plane area is minimal consistent with achieving the desired shape transition. This mathematically derived, axisymmetric contraction resulted in a shorter contraction length than those generated by other methods. Direct application of this axisymmetric design to the proposed facility may lead to some difficulties in tunnel filling and operation at lower test section velocities. For an axisymmetric contraction stemming from an air separator of 28 ft dia., the top of the upstream end of the contraction would be about 12 ft above the level of the free surface of the test stream. If the test stream ambient pressure is atmospheric, the test section velocity should be greater than about 28 fps to avoid subatmospheric pressure at the uppermost point of the contraction. As lower operational speeds may be contemplated, it is proposed to utilize an unsymmetrical contraction, thereby reducing the static head between the separator dome and the test section free surface and permitting lower velocities.

It is also suggested that the contraction terminate in a sharp-edged lip, thereby permitting an additional downstream contraction of the free surface before the test section proper is entered. Hopefully, this may reduce the effects of boundary layer development on the stability of the free surface. At this time a tentative concept of the contraction shape has been formulated, but no dimensional values have been established. The

contraction and the test section entrance must be given extensive further study, and model studies must be carried out to evaluate the flow quality resulting from the complete system.

The head loss through the contraction is usually determined from model studies of a given geometry. As these results are not presently available, it was assumed for purposes of preliminary head loss computations that 3 per cent of the test stream velocity head was lost in the contraction.

For purposes of preliminary sizing of the proposed tunnel as shown in Fig. 1, a settling length downstream of the honeycomb has been tentatively set at 2 ft followed by a contraction with an overall tentative length of 25 ft.

The geometrical complexities of the contraction into the test section are one of the principal reasons for recommending that a variable-depth test section be dropped from further consideration. In this regard it should be noted that the pressure drop along the contraction is approximately 70 psi when the test section is operating at the top speed of 100 fps.

REFERENCES

- [F-1] Ripken, J. F. and Holdhusen, J. S., Model Experiments for the Design of a Sixty-Inch Water Tunnel, Part II, Contraction Studies, Project Report No. 11, St. Anthony Falls Hydraulic Laboratory, 1948, 22 p.
- [F-2] Basting, W. J., "The Design of a Contracting Duct for a Water Tunnel," Journal of Hydraulic Research, Vol. 8, No. 3, 1970, pp. 317-328.
- [F-3] Worschauer, K. A., "Hydrodynamic Design of the TNO-Water Tunnel for High Reynolds Numbers," Journal of Hydraulic Research, Vol. 8, No. 3, 1970, pp. 365-375.

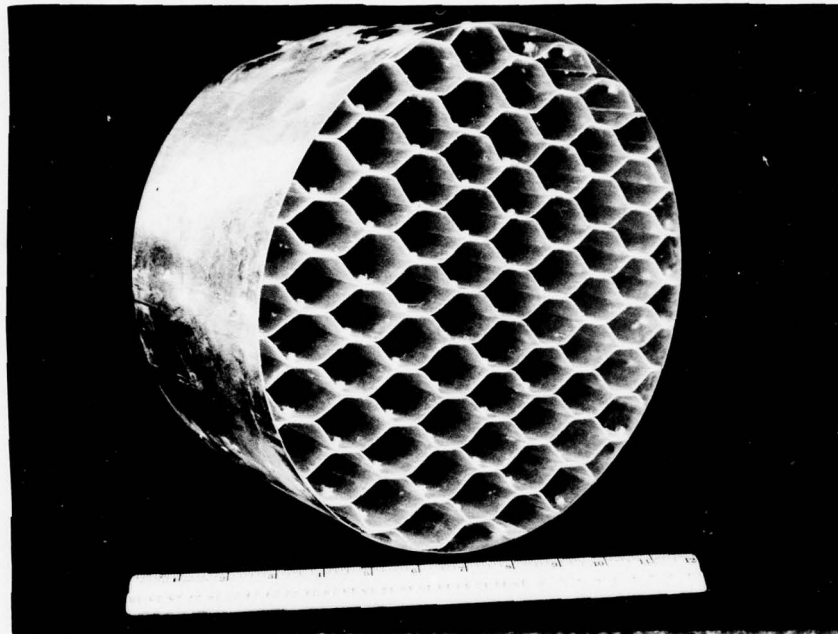

Fig. F-1 - Honeycomb Flow Straightener Used in 12-Inch Pipe Employed for Free-Surface Stability Tests

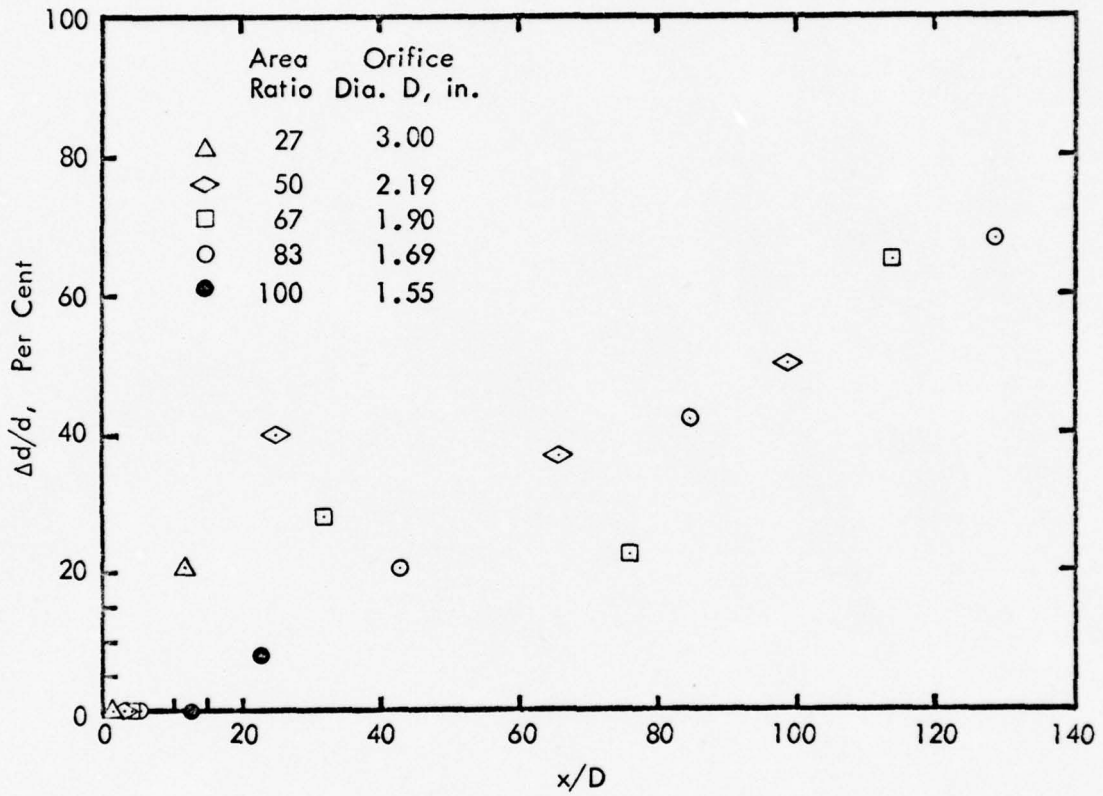

Fig. F-2 - Effect of Area Ratio on Surface Disturbance of High Speed Circular Free Jets

Appendix G
ENERGY AND PUMP REQUIREMENTS

A. General Considerations

The function of the recirculating pump in the tunnel loop is to supply energy to the water in such quantity and manner as to maintain the desired flow conditions in the facility test section. The primary problems in arriving at the best selection for the pump are

1. Establishing the maximum or critical performance demanded of the pump in terms of discharge and head necessary to satisfy the operational requirements of the facility.
2. From the established demands and prior art, determining the preferred type and size of pump.
3. Examining the performance characteristics or criticals of the selected pump with respect to its suitability in satisfying the facility flow needs at other than high or maximum flow rates.

Important secondary requirements to be considered are

1. That the velocity of the stream discharging from the pump be as precisely controllable and as free of fluctuation or drift as possible. Since the flowing mass in the tunnel loop is very large, the mass inertia or flywheel effect is also very large. Because of this, short time variations are not contemplated, but long-time drift could be generated by various sources. It is assumed that suitable controls in a variable speed drive could adequately counter such drifts.
2. That flow in the test section be substantially free of rotation. Such rotation is suppressed rather than generated by most of the tunnel circuit components aside from the pump. Certain types of pumps, most notably the axial flow type, inherently contribute rotation to their discharging flow unless fitted with corrective vaning. Specifications should require that the vaning correct most of the discharge rotation at all rates of flow. Pump discharge rotation is probably of less importance in the proposed loop of Fig. 1 than it was in previous NSRDC tunnels because of the

substantial rectification provided by the proposed new air separator and its diffuser.

3. That normal tunnel operations be possible with the pump operating at a relatively high energy efficiency. This is important not only for conservation of input energy and reduction of thermal build-up, but also because low efficiency introduces pressure pulsations or turbulence as a by-product of separation and vorticity.
4. That the pump be as free of cavitation as possible. This applies not only to the substantial cavitation that could yield reduced performance, but also to any minor local cavitation that might produce significant background noise in the tunnel system.

In considering the above requirements it is important to appreciate that the pump for the proposed facility will be a custom-built machine of a type that can be supplied by only a few specialized makers. It is unlikely that any maker has supplied a machine that closely duplicates the needs of this pump. It will, therefore, probably be necessary to require model studies by the pump maker to clearly establish his ability to meet the above requirements. Since the desired information is not available to the consumer-engineer prior to such tests, he is confined to formulating somewhat idealized specifications which the maker may or may not be able to achieve precisely.

B. Discharge-Head Relations

The maximum discharge requirements of the tunnel pump are fixed by the test section size and the maximum test speed initially specified by NSRDC. As discussed in Appendix A, this is essentially a 3 ft by 3 ft test section with a maximum mean velocity of 100 fps and a resulting discharge of 900 cfs. In order to avoid gravitational disturbances of the free surface of the test section, the minimum suggested operating velocity is 15 fps with a resulting minimum discharge of 135 cfs. The pump should, of course, be capable of transient operations down to zero discharge.

The head against which the pump should operate would be variable and would depend on the selected discharge. This head is a function of the design flow efficiency of the total tunnel loop constituted of various loop components. In an attempt to evaluate the magnitude of the total energy head requirements for the purpose of preliminary pump design, prior art was

examined for the energy losses which might be contributed by each of the major flow components of the tunnel circuit. This background involved pipe friction theory, related component studies for wind tunnels, and previous water tunnel studies, most notably those done at St. Anthony Falls for the development of the present NSRDC 36-inch water tunnel. In addition to prior art investigations, limited special experimental tests were conducted under the current study to evaluate head loss in the new type of separator and diffuser. The information obtained has been summarized for the proposed new facility in conformance with a method developed many years ago for wind tunnel studies. According to this method, energy head values are determined and expressed for each significant individual energy component of the tunnel loop and these components are then summed to yield the total energy needs. To facilitate comparisons, all losses computed by this method are arbitrarily expressed as a portion of the kinetic energy that will exist in the test section jet at a given velocity.

The test section kinetic energy per pound of water, E , is given by $E = V_o^2/2g$ where V_o is the mean test section velocity in fps.

The total energy of the test section flow, expressed in horsepower, is

$$HP = Q\gamma E/550$$

where Q is the discharge in cfs and can be expressed as $Q = V_o A_o$ where A_o is the cross sectional area of the test section and where γ is the specific weight of fresh water ($\gamma = 62.4$ lbs/cu ft).

For the maximum design flow of $V_o = 100$ fps in a 3 ft by 3 ft test section the jet energy is

$$HP = [(100 \times 3 \times 3) 62.4 \times 100^2/2g]/550 = 15,800 \text{ HP}$$

The rate of energy input required to maintain the above jet energy is the summation of the losses of the individual circuit components and can be expressed as

$$HP = V_o A_o \gamma [\sum K_o V_o^2/2g]/550$$

In using experimental data to establish K_o in this equation, it is usually convenient to first interpret the local loss of a component as

$K_n V_n^2 / 2g$ where V_n is the local mean velocity through the effective cross-sectional area A_n of the particular component. These local energy head loss values can be normalized to the K_o base by employing the discharge continuity equation

$$Q = V_n A_n = V_o A_o$$

This leads to a relation between local loss expressions and the loss expression in terms of test section values as

$$K_o = K_n (A_o / A_n)^2$$

On the basis of this method of summarizing the energy demands or input, the K_o values for the various circuit components (evaluated in the various appendices of this report) are tabulated in the accompanying Table G-1 and reinterpreted as head values and shown graphically in Fig. G-1. These data were calculated for test section velocities of 10, 50, and 100 fps and relate to the prototype dimensions of Fig. 1. It should be noted that a number of the circuit components are influenced by viscosity and that K_n or K_o values vary with the test velocity. It should also be noted that energy loss values are given for both the bare test section and a test section fitted with a high drag test body. For purposes of calculation, the test body was assumed to have a diameter one-sixth of the test section dimension of 3 ft and a conventional drag coefficient value of 1.00. In addition, the test body was considered to adversely influence the diffuser loss.

The estimated energy head losses for the bare tunnel are believed to be fairly representative of those which may ultimately be obtained in such a facility, but the values for the tunnel with test body are in need of further validation. This is true because the component contributing the greatest loss to the total is the diffuser pickup just downstream of the test section. The prior art of diffusers is well documented with evidence that the energy demands of even simple diffusers are quite sensitive to input velocity profiles. In the proposed facility three additional complications are imposed on this diffuser. They are as follows:

1. A high-drag test model in the test section can distort the velocity profile of the flow entering the diffuser in a wide

Table G-1

ESTIMATED ENERGY LOSS FACTORS FOR THE PROPOSED PROTOTYPE FACILITY
(Loss expressed as K_0 multiples of the test section velocity head)

Tunnel Element	Form Loss K	Total Loss Coeff. Estimate		
		Test Section Vel in fps		
		10	50	100
Contraction	--	.0300	.0300	.0300
Test Section	--	.0520	.0420	.0380
Diffuser I	.0686	.0891	.0854	.0842
Vaned Elbow I	.0122	.0136	.0133	.0132
Diffuser II	.0075	.0084	.0083	.0082
Vaned Elbow II	.0154	.0166	.0163	.0163
Diffuser III	.0066	.0071	.0070	.0069
Vaned Elbow III	.0021	.0021	.0021	.0021
11' D pipe, L = 94'	--	.0009	.0007	.0007
Elbow + Separator	--	.0120	.0120	.0120
Σk (Bare Tunnel)	--	.2318	.2171	.2116
Σk (with Test Body)	--	.3222	.3075	.3020
Energy Ratio	Bare Tunnel	.305	.285	.278
	with Test Body	.424	.405	.398

variety of ways depending on the model's geometric configuration and operation.

2. Concurrent entrainment or injection of large quantities of gas provides volume displacements and elastic mechanisms of questionable effect.
3. The introduction of a free-surface skimmer and pickup at the ceiling of the diffuser entrance involves boundary layer abnormalities and possible cavitation choking. There appears to be no prior art with high speed devices of this kind.

In view of the foregoing problems, the accuracy of the upper energy demand curve of Fig. G-1 is not well established, and comprehensive model evaluations are strongly recommended.

The determination and study of the K_0 values for various elements of the tunnel lead to an insight into the influence and importance of component energy efficiencies. It should, however, be noted that additional insight into the total tunnel energy demands is obtainable through determination of a parameter known as the "energy ratio." This quantity is sometimes defined as the ratio of the external power input to the power of the test section jet. For the current estimate it will be assumed that an electrical drive delivers 95 per cent of the input energy and that the pump efficiency is 85 per cent at maximum, but possibly only 80 per cent for test conditions. To provide additional insight into energy demands, values of this energy ratio have been added to Table G-1 for the case of $V_0 = 100$ fps and input electrical energy curves have been added to Fig. G-1.

C. Pump Location

Pumps for cavitation tunnels have in the past frequently been located in the tunnel loop in the position shown in Figs. D-9 and D-10. Location in the lower leg placed the pump at the lowest possible position and thus made maximum use of available static head to suppress pump cavitation. Location of the pump in the corner farthest from the tunnel contraction permitted a relatively short driving shaft and a maximum flow length to allow pump flow abnormalities to decay before entering the test section.

In the currently proposed tunnel neither of the above requirements is as stringent as in past tunnels. First, if the tunnel is to be used exclusively for high speed tests, substantial pressure head is recovered in the main diffuser, and the pump is less subject to low cavitating pressures. For these conditions, placement at the lowest possible position is not essential. Second, a new tunnel containing a diffuser-separator contraction of the form shown in Fig. 1 is inherently able to considerably damp pump distortions before they can enter the test section. Accordingly, it is conceivable that pumps could be mounted in the vicinity of either of the lower elbows with either horizontal or vertical shafts. Past experience with horizontal shafts indicates no serious problems in fabricating or operating with this type of pump, but for many large high-head types of pumps and hydraulic turbines the vertical shaft arrangement has long found favor, primarily because of the mechanical simplicity attending the use of a single Kingsbury type thrust bearing to carry the rotor loads of both the

driving motor and the pump. This includes dead weight as well as hydraulic thrust. For optimum utilization of this loading arrangement, the pump for the proposed facility might best be located in the vertical leg upstream of the air separator. A pump similarly oriented and requiring similar discharge, but greater heads than are required by Fig. G-1 is described in Ref. [G-1] and shown in Fig. G-2.

The above-described vertical arrangement has a number of attractive features. However, satisfactory water tunnel experience with the pump located as shown in Fig. 1 commends this more conservative approach, and it is tentatively recommended for adoption.

D. Pump Type

Most existing water tunnels have employed axial flow propeller-type pumps, and these have proven quite satisfactory. This type of pump provides the most compact and least expensive construction where pump head can be kept below about 40 ft. In the NSRDC 36-inch tunnel a pump head of 34 ft is capable of producing workable test section speeds of 85 fps. For the proposed facility the head might be as large as 48 ft, as is shown in Fig. G-1. This head value exceeds the usual head limits of a purely axial machine, and model pump tests will probably be necessary to establish the exact form of impeller. The high operating pressure conditions may permit an axial flow machine, but the pump maker may prefer to offer a mixed flow machine somewhat similar to the one shown in Fig. G-2b. Preliminary estimates indicate that an axial machine can probably be designed for the new service and that it will probably have a specific speed of about 11,000 to 12,000 if a shaft speed of around 300 rpm is used. The pump of the present NSRDC 36-inch tunnel has a similar specific speed, but operates at a lower shaft speed and is of a smaller size than would be required by the demand conditions of Fig. G-1. The specific speed is a commonly used pump selection parameter involving the variables usually entering into pump selection and is evaluated under optimum efficiency conditions using the expression

$$N_s = \text{shaft rpm} \sqrt{\text{discharge in gpm}/(\text{head})^{3/4}}$$

With regard to the adoption of an axial flow pump, prior art has established that certain operating limitations are inherent in the machine's performance. Most notably, these limitations are

1. A tendency to cavitate when operating under low imposed head and large discharge. This condition is shown at the far right in Fig. G-3, which typifies the approximate form of performance curve that would apply to a pump selected for the conditions imposed by the proposed facility ($N_s \approx 11,700$). The steeply rising critical cavitation σ curve required by the pump will ultimately intersect the critical cavitation σ curve required by the tunnel as shown in Fig. G-5. This intersection will establish the maximum workable discharge, which is shown as point A in Fig. G-3. Point A can be rigorously established only after specific model tests have established a tunnel characteristic curve such as in Fig. G-5 and other pump model tests by the pump maker have established the critical σ curve for the selected design.
2. A tendency toward a leveling or even a dip in the head discharge curve which usually occurs in the mid-range of discharge values for this type of pump. Such conditions produce an instability or roughness of flow, and operation in this range should be limited to discharges greater than that represented by point B. Point B is determined by observations in a suitable pump model test conducted by the pump maker.

In view of the above pump limitations, effective operation of the pump should be confined to the region between A and B on the head discharge curve shown in Fig. G-3 and repeated in Fig. G-4. Since the curve BA in Fig. G-3 relates to a particular shaft operating speed, the addition of a tunnel head requirement curve as derived in Fig. G-1 establishes an intersection which defines the single test section speed at which a given tunnel configuration will operate with the given pump and pump speed. Selected operation of the tunnel through a full range of velocities (15 to 100 fps in this tunnel) will require variation of either the pump blade angle or the shaft speed.

At the present time it is believed that there is little or no interest on the part of competent American pump builders in bidding on a variable blade pump of the type required. There are, however, no unusual problems in procuring a variable speed drive for this type of operation, and thus for the purposes of this preliminary study a variable speed drive with a fixed blade pump is proposed.

The established speed laws for this type of pump are given by

$$Q_1/Q_2 = N_1/N_2 \quad \text{and} \quad H_1/H_2 = (N_1/N_2)^2$$

Application of these laws to the operating range curve BA of Fig. G-3 permits the operating range of the pump to be established for various speed conditions as shown in Fig. G-4. The values shown in Fig. G-4 are estimates. It would be the objective of a future model tunnel study to more firmly establish the two head requirement curves shown. With these in hand, model pump tests could be made to establish a pump design whose performance capabilities could properly envelop the operating range required for the tunnel. Figure G-4 shows a shaded area representing such an envelope of operating potential for an axial flow pump of $N_s = 11,700$.

It should be noted that not only should pump selection include the tunnel operating conditions between pump operating limits A and B, but reasonably good operating efficiencies should exist over the range required by the tunnel operating conditions. This is desirable for both energy conservation and smooth tunnel performance. For a large axial flow pump of the type which would apply here, the best efficiency would probably approximate 85 per cent at high speeds and would diminish slightly as speed diminished. The typical efficiency curve of Fig. G-3 indicates that if the pump output curves can be well matched with the tunnel demand curves as shown in Fig. G-4, operating pump efficiencies can be kept within 5 per cent of the optimum pump efficiency.

E. Pump Size

It is estimated that the preferred pump selection would require an entrance and discharge diameter of about 7.5 ft. These dimensions would ultimately be determined by the pump maker's model studies, but the above value is believed to be satisfactory for preliminary tunnel sizing. Ultimate small deviations from these values are not considered critical, because for other reasons a diffuser-shape transition would probably be employed directly ahead of the pump and a short diffuser directly after the pump. These diffusers can accommodate any diameter adjustments that may ultimately prove necessary in adjusting pump dimensions to other dimensional fixes in the adjoining structure.

F. Pump Cavitation

Since the facility is designed to provide relatively severe cavitation conditions in the test section, all tunnel elements in the low pressure region between the test section and the pump should be suspected of operating with possible local cavitation problems. The pump is particularly suspect because of the high relative blade velocities that are involved in its operation. To prevent such cavitation the proposed tunnel circuit must be examined relative to the discharge-pressure conditions that will exist at the pump entrance for projected operating conditions. This available pressure must then be checked to see that it exceeds the suction pressure requirements of the proposed pump. These comparisons are most effectively made by employing suitable cavitation σ values for the tunnel and the pump. The pump σ value required to avoid cavitation as employed herein is given by

$$\sigma = \frac{P_s - P_{vp}}{\gamma H}$$

where P_s = absolute static pressure at the centerline of the pump suction in lbs per sq ft
 P_{vp} = vapor pressure in lbs per sq ft
 γ = specific weight of fluid in lbs per cu ft
 H = head added by pump in ft

Application of the above index shows that the least tolerable value will occur when incipient cavitation exists at the crown of the tunnel diffuser transition (designated by the subscript d). Using this point as a minimal pressure source, the pressure at the centerline of the pump suction (designated by subscript s) can be computed by relating the pressures at these points through a Bernoulli energy equation thus:

$$\alpha_d \frac{\bar{V}_d^2}{2g} + \frac{P_d}{\gamma} + Z_d - h_l = \alpha_s \frac{\bar{V}_s^2}{2g} + \frac{P_s}{\gamma} + Z_s$$

where α = kinetic energy correction factor
 P = absolute pressure in lbs per sq ft
 \bar{V} = mean velocity of flow in fps
 Z = height above datum in ft
 h_l = head loss between d and s

For preliminary estimates assume that $\alpha_d = 0.9$, $P_d = P_{vp}$, $(Z_d - Z_s) = 35$ ft, $\alpha_s = 1.1$, $A_d = 3 \times 3 = 9$ sq ft, $A_s = 44$ sq ft, and $h_{\ell} = 0.193 V_d^2 / 2g$ (from Table G-1 with test body). This yields

$$\frac{P_s}{\gamma} - \frac{P_{vp}}{\gamma} = \left[\alpha_d - \alpha_s \left(\frac{A_d}{A_s} \right)^2 \right] \frac{V_d^2}{2g} + (Z_d - Z_s) - 0.193 \frac{V_d^2}{2g} = 0.661 \frac{V_d^2}{2g} + 35$$

If $(P_s/\gamma - P_{vp}/\gamma)$ is computed for a range of test section velocities from 0 to 100 fps, the values of σ can be computed from the initial definition equation. Such computed values are shown graphically in Fig. G-5. For the calculation of σ , H was presumed to relate to a best efficiency condition lying midway between the "bare tunnel" and "test body" curves of Fig. G-4. This assumes that N_s remains constant as the speed varies.

The curve of Fig. G-5 defines the approximate values of cavitation parameters expected to exist at the prototype pump suction. The question now is whether the prior art of pump design can be expected to define a pump with cavitation susceptibilities that are better than these facility potentials. Exact values of a pump's cavitation tolerance are best defined through model tests of the particular machine to be used. Typical data for σ for a pump of $N_s = 11,700$ are shown in Fig. G-3. As stated earlier, the intersection of the tunnel σ curve with the pump σ curve establishes the maximum useful discharge that can be employed for a given operating condition as marked by point A in Fig. G-3. Because of the steep slope of the pump σ curve in the vicinity of the intersection, a conservative approach to cavitation suggests arbitrarily locating A somewhat farther to the left or farther up the Q-H curve. Similar checks made for lesser pump speeds indicate that the cavitation susceptibility tends to diminish as speed diminishes. A study of Figs. G-3 and G-4 indicates that a pump with an N_s of no more than 11,700 should satisfy all operating conditions without significant cavitation.

It should be noted that the critical pump σ data of Fig. G-3 relate to cavitation which critically affects the pump performance. This does not preclude the possibility of small secondary cavitation which may be sufficient to cause audible noise or minor erosion. The location, nature, and severity of this secondary cavitation should be sought in the detailed pump model study conducted by the pump maker.

G. Inlet Velocity Distribution

A pump of the selected specific speed value is moderately sensitive to the pattern and uniformity of approach flow. In order to maintain a flow as uniform as possible in a position just downstream of a vaned elbow, some care in the selection of the elbow vaning is necessary. It is suggested that the elbow design follow the same design concept employed in the pump elbow of the NSRDC 36-inch tunnel. In this design a central fairing was provided to streamline the obstructing pump shaft, and the turning vanes extended from the outer shell to the central fairing. With this relatively short span a large number of small vanes can be employed without undue structural problems with the small vane. With a small pattern of vaning the vane wakes decay in a short distance and the pump inlet can be placed quite close to the elbow without serious inlet flow patterns. The close-up positioning permits a desirable shortening of the pump drive shaft.

H. Influence of Entrained Air on Pump Performance

Pumps are not usually required to operate with significant quantities of air in the entering flow. In view of the substantial air flows anticipated for the proposed NSRDC facility it was considered desirable to know whether the air would be detrimental to the pump performance. To obtain some insight into the effect which large quantities of entrained gas would have on the pump output, tests were conducted in the 42-inch St. Anthony Falls tunnel in which gas was injected upstream of the pump. This gas was injected at location V in Fig. D-10 through a manifold constructed of 3/4 inch copper pipe of 1.5 ft length and projected normal to the boundary. Numerous small orifices were drilled in the pipe to inject the air in the form of a bubble screen.

The results of this study show that the pump output is reduced by only a fraction of one per cent at the expected air load (3000 vppm). In order to more fully investigate this problem, air loads of up to 5 per cent were employed in the tests. In no case was the discharge reduced more than 6 per cent. These results are presented in Fig. G-6.

Observations were also made concerning the stability of the flow in the test section while various gas loads were being applied to the pump. These observations were made with a standard Price cup-type current meter which was judged to have an adequate response time compared to that of the

tunnel circuit. No velocity fluctuation from a mean value could be detected with an electronic timing readout under any condition of air admission. The very large inertia of the total flow system apparently has a very stabilizing influence on mean flow conditions despite accompanying changes in the elastic characteristics of the water.

It should be noted that the pump in this tunnel is a four-bladed axial flow type having a specific speed of about 11,000. At the time of the tests the circuit resistance imposed a head of about 5 to 10 ft on the pump. It is anticipated that operations with a greater head (up to 48 ft in the proposed facility) would produce even smaller gas response.

I. Model Studies

A detailed model study of the entire tunnel loop is recommended. This is especially important for firming up the energy requirement estimates presented in Table G-1 and Fig. G-1. The estimate data are based on the best available information relating to various component elements of a tunnel loop and are probably fairly realistic. However, short coupled elements in a tunnel loop have substantial mutual flow effects and can best be evaluated in a complete model. The facility model also permits the use of a variety of test configurations and programmed gas injection which would strongly affect the performance of the main diffuser and the other elements preceding the pump. These actions have a major effect on the locale of the test body curve of Fig. G-4 and the cavitation curves of Fig. G-5. The locale of these curves in turn has a major influence on the selection of the pump design conditions.

It is recommended that, if possible, the model study be conducted up to full prototype test section speeds.

REFERENCE

- [G-1] Johnson, Ernest H., "Large Combined Axial- and Mixed-Flow Pump," ASME Meeting Paper 69 WA/FE-31, 1969.

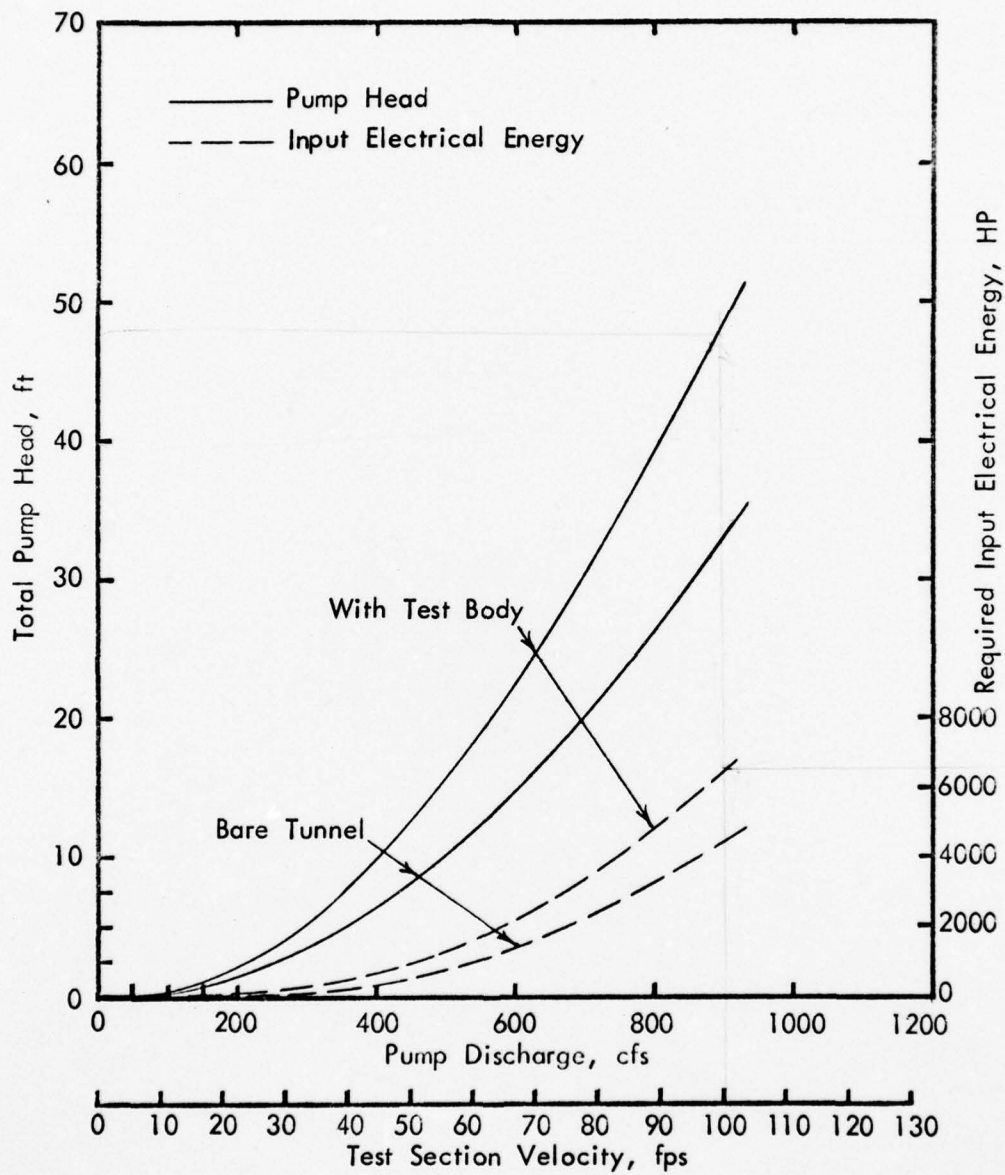
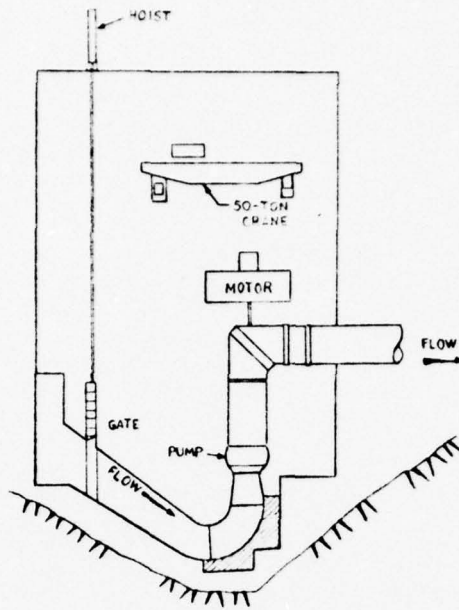
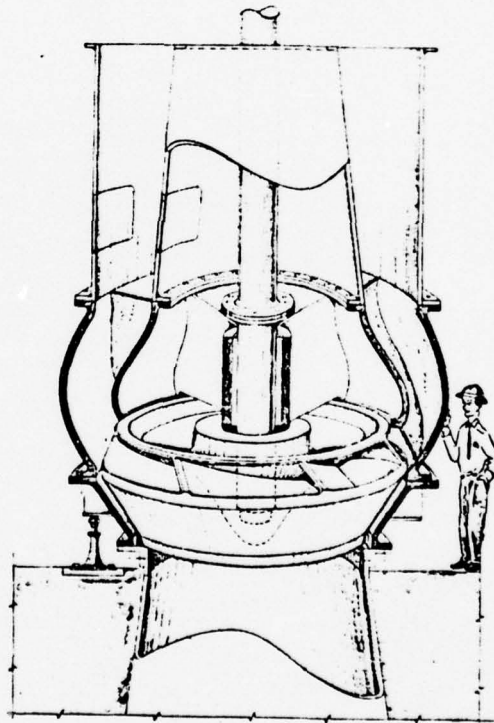

Fig. G-1 - Preliminary Discharge, Head, and Power Requirements for the Pump Proposed for a New Facility



(a) General Orientation



(b) Bowl Assembly

Fig. G-2 - Orientation and Bowl Arrangement for Vertical Shaft Pump with a Design Rating of $Q = 850$ cfs and $H = 65$ ft (from Ref. [G-1])

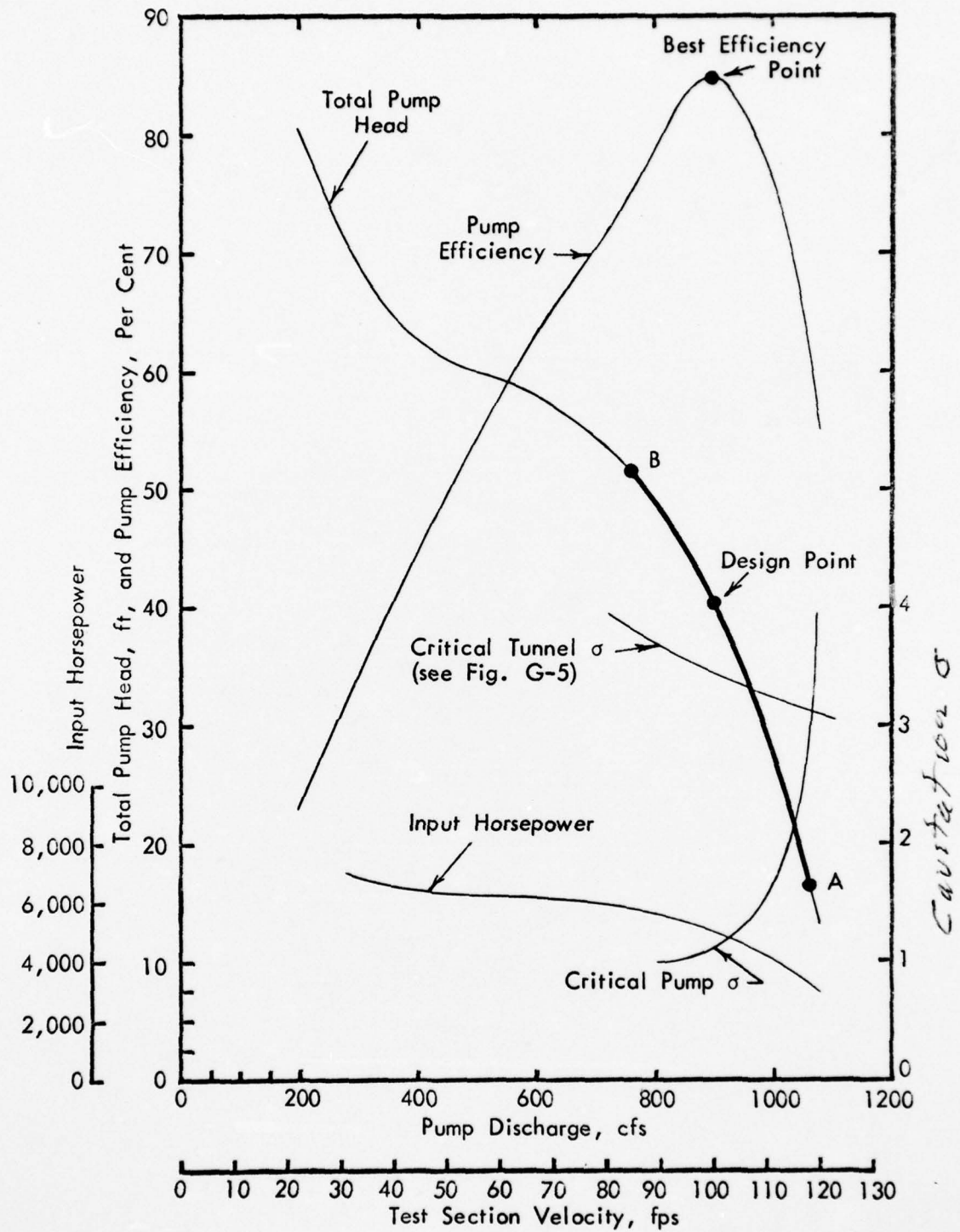

Fig. G-3 - Typical Performance Curves for an Axial Flow Pump of $N_s = 11,700$ Operating at $N = 292$ rpm

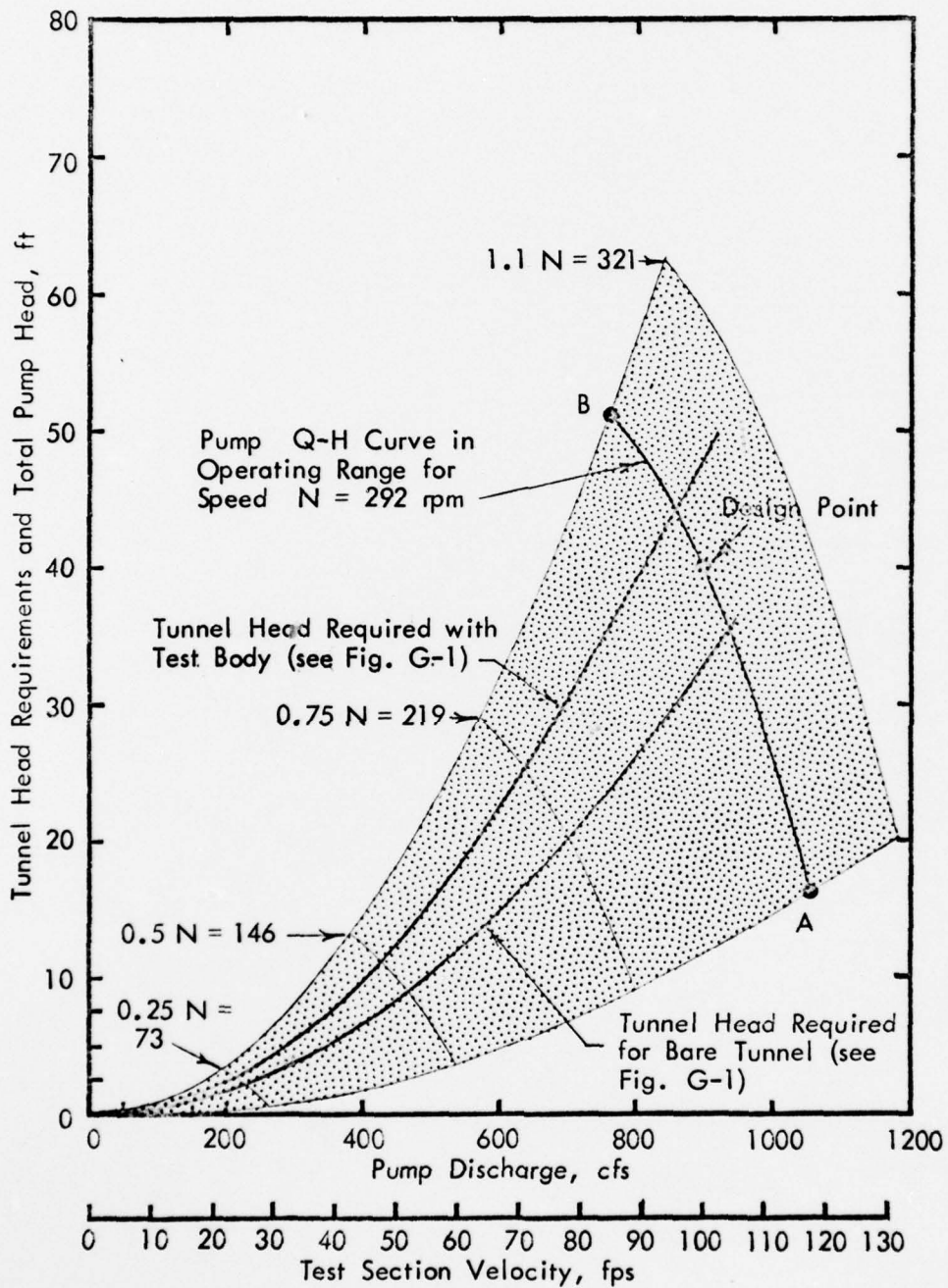

Fig. G-4 - Matching of Pump Total Head with Tunnel Head Requirements for Various Operating Speeds Assuming the Pump of Fig. G-3

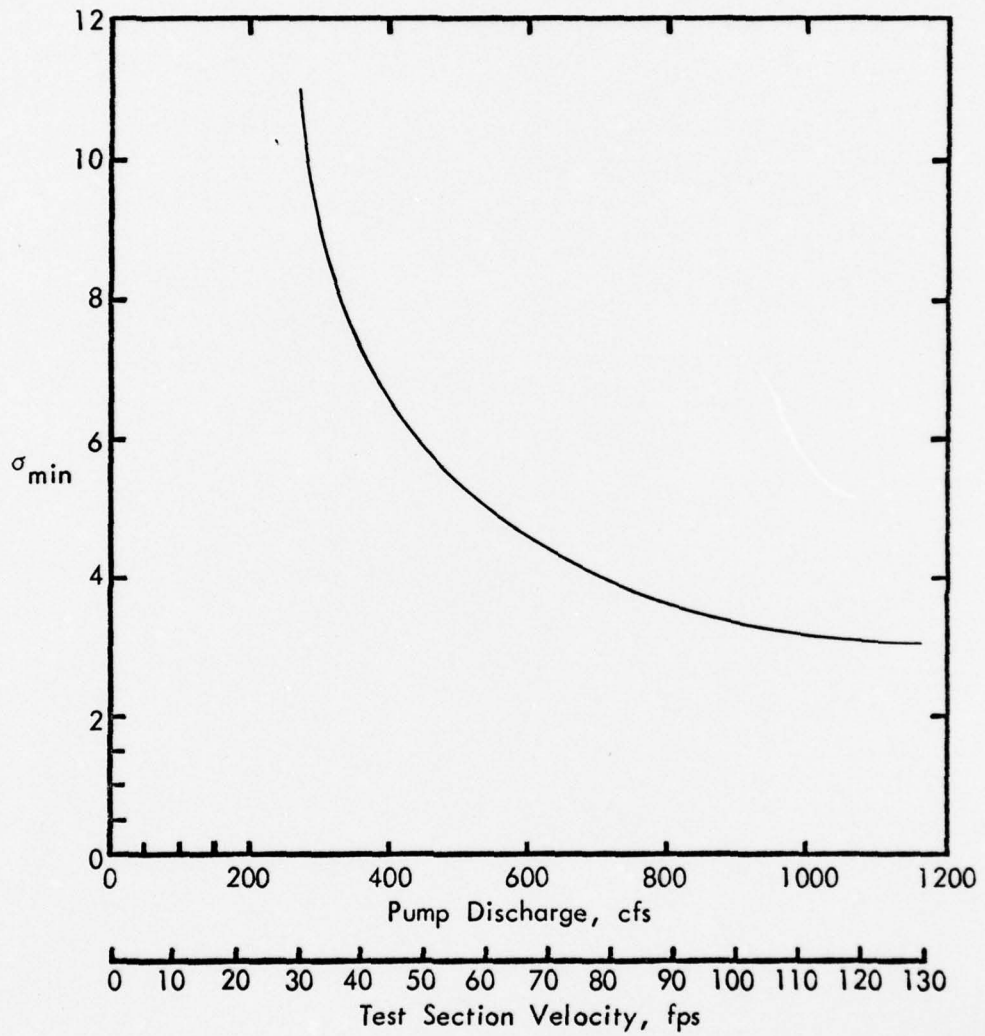

Fig. G-5 - Estimated Minimum Cavitation Index Provided in Tunnel at Centerline of Prototype Pump Intake

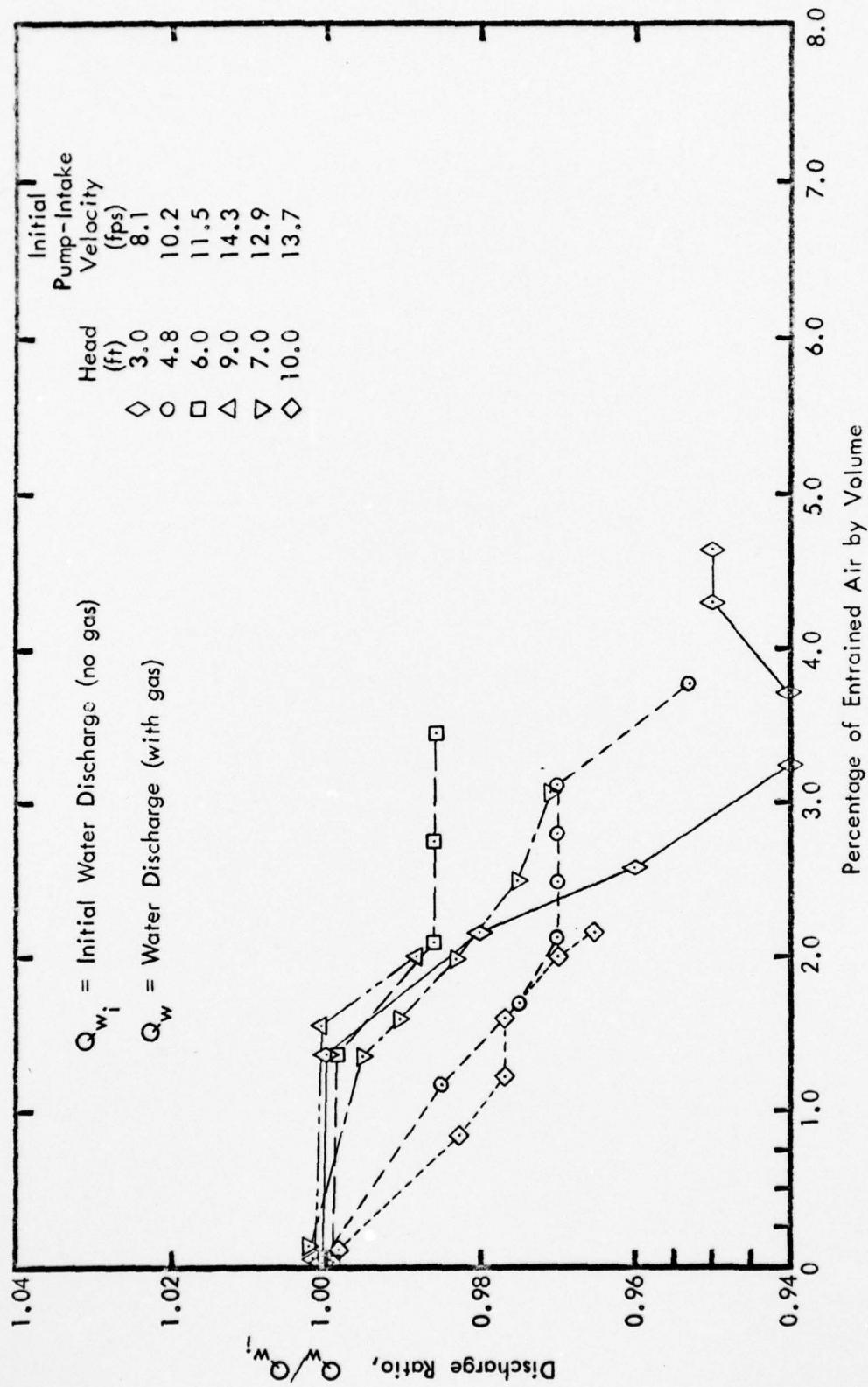

Fig. G-6 - Influence of Air Injection on the Performance of the SAF 42-Inch Tunnel

Appendix H
AUXILIARIES

A. Pressure Control

In the routine operation of the water tunnel it is desirable to maintain constant pressure and temperature conditions in addition to the desired test section velocity. Pressure control has been achieved in many cases by utilizing an attached expansion tank with suitable vacuum and compression equipment. Lines from the tops of the air separation and contraction chambers to the expansion tank should be provided to allow any gas accumulation to escape from the tunnel loop.

B. Surface Gas Separation at the Diffuser Entrance

It is expected that a considerable portion of the entrained gas will be separated by a skimmer located at the entrance to the test section diffuser. It is anticipated that up to 5 per cent of the flow depth may have to be skimmed from the free surface at this location in order to prevent excessive ingestion of air into the tunnel loop. Model studies should be made to establish methods for minimizing this skimming.

Skimmer design must be concerned not only with promoting a smooth flow of the main stream into the diffuser entrance, but also with smoothly routing the skimmed flow into a local air separator. This separator must remove the major portion of its entrained air and permit controlled return of the water to the tunnel circuit. To the extent that it is practical, the separator should also recover as much of the kinetic energy of the skimmed flow as possible. (At maximum speed a flow of 45 cfs containing approximately 800 HP is involved.) A number of possibilities exist for this separation-recovery mechanism, including a gravity decelerator, a hydraulic jump, and a cyclone. It is recommended that small pilot experiments be made to establish a feasible mechanism for inclusion in a more complete model tunnel study. It is anticipated that the separated water could be advantageously readmitted to the tunnel loop by tangential injection into the boundary layer near the diffuser entrance for the suppression of boundary layer separation. If the separated water can be returned to the flow circuit in the low pressure region of the main diffuser, re-energizing can be accomplished by the main tunnel pump. Readmission at any other part of the tunnel loop will probably require re-energizing with auxiliary pumps.

C. Cooling and Heat Transfer

Using the estimated K_o total of 0.302 from Table G-1, the mechanical energy lost in the tunnel loop at maximum flow is 2.7×10^6 ft lbs/sec. This energy loss is converted to heat added to the water at the rate of 12.6×10^6 BTU/hr. If none of this heat were removed, the estimated 1.93×10^6 lbs of water contained in the tunnel loop would experience a 6.5°F/hr rise in temperature.

Heat loss calculations indicate that for an estimated tunnel wall surface area of 8900 sq ft and a 10°F differential between the test water and the tunnel housing temperature, only 0.27×10^6 BTU/hr is removed.

If constant or near constant temperature operation is required, heat must be removed from the water, and incorporation of a heat exchanger into the skimmed water processing mechanism may be feasible. A detailed engineering study would be required for an optimum design. Another possible means of heat removal might be the utilization of the turning vane surfaces in the elbows as heat transfer surfaces. These vanes would probably be of hollow construction anyway, and coolant could be circulated through them without necessitating the withdrawal of water from the tunnel. No additional head loss need be assessed to the tunnel pump for cooling purposes. However, if small temperature increases can be tolerated, or if the periods of tunnel operation are relatively brief compared with the shutdown periods, it is possible that a heat removal system will not be necessary.