

see 1473

12

ADA 040 134

Project Report

TT-18

Real Time Digital Recording
of Thermovision Data

R. J. Cordova
R. R. Parenti

2 March 1977

Prepared for the Defense Advanced Research Projects Agency
under Electronic Systems Division Contract F19628-76-C-0002 by

Lincoln Laboratory

MASSACHUSETTS INSTITUTE OF TECHNOLOGY
LEXINGTON, MASSACHUSETTS



Approved for public release; distribution unlimited.

AD No. _____
DDC FILE COPY



The work reported in this document was performed at Lincoln Laboratory, a center for research operated by Massachusetts Institute of Technology. This work was sponsored by the Defense Advanced Research Projects Agency under Air Force Contract F19628-76-C-0002 (ARPA Order 2752).

This report may be reproduced to satisfy needs of U.S. Government agencies.

The views and conclusions contained in this document are those of the contractor and should not be interpreted as necessarily representing the official policies, either expressed or implied, of the United States Government.

This technical report has been reviewed and is approved for publication.

FOR THE COMMANDER



Raymond L. Leinelle, Lt. Col., USAF
Chief, ESD Lincoln Laboratory Project Office

MASSACHUSETTS INSTITUTE OF TECHNOLOGY
LINCOLN LABORATORY

REAL TIME DIGITAL RECORDING
OF THERMOVISION DATA

R. J. CORDOVA

R. R. PARENTI

Group 53

ACCESSION for		
NTIS	White Section	<input checked="" type="checkbox"/>
DDB	Buff Section	<input type="checkbox"/>
UNANNOUNCED		<input type="checkbox"/>
JUSTIFICATION		
BY		
DISTRIBUTION/AVAILABILITY CODES		
Dist.	AVAIL. CODE	SPECIAL
A		

PROJECT REPORT TT-18

2 MARCH 1977

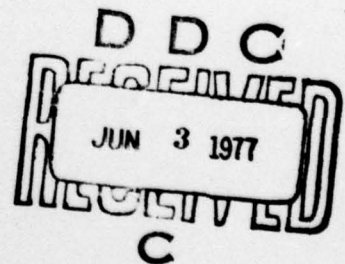

Approved for public release; distribution unlimited.

LEXINGTON

MASSACHUSETTS

ABSTRACT

A direct, real time, video to digital data recording system has been developed to record $10\mu\text{m}$ thermal imagery in conjunction with an AGA 680 LW camera. This device is now being used to study the thermal characteristics of various types of natural terrain for the purpose of developing tactical target acquisition techniques.

This data recording system consists of an analog to digital interface, NOVA 2/10 minicomputer, and magnetic tape transport and is designed to record 16 frames per second at a 175 kHz instantaneous digitization rate with 8 bit precision. Computer controlled timing circuits group pairs of 8 bit data words into a single 16 bit NOVA compatible word in an intermediate buffer which is then transferred into core memory. The minicomputer stores complete frames of data during the active camera scan period while simultaneously maintaining a constant 88,000 word/second transfer rate to the 9 track magnetic tape unit. The final data format consists of a 74×74 picture element array with 0.2°C temperature resolution and 50°C dynamic range.

CONTENTS

ABSTRACT	iii
LIST OF ILLUSTRATIONS	vi
1. INTRODUCTION	1
2. EQUIPMENT	5
3. DATA RECORDING TECHNIQUE	7
4. SYSTEM PERFORMANCE	13
5. CONCLUSIONS	14
APPENDIX	16
ACKNOWLEDGMENT	25

PRECEDING PAGE BLANK-NOT FILMED

LIST OF ILLUSTRATIONS

Fig. 1-1a.	Film recording method.	2
Fig. 1-1b.	Analog recording method.	3
Fig. 1-1c.	Direct digital recording method.	4
Fig. 2-1.	Real time digital recording system.	6
Fig. 3-1.	Hardware flow chart.	9
Fig. 3-2.	Offset and gain circuit.	10
Fig. 3-3.	Digitization window circuit.	11
Fig. 3-4.	Software flow chart.	12
Fig. A-1.	5.75 μ s clock.	17
Fig. A-2.	Sample/hold and analog/digital converter.	18
Fig. A-3.	Digitizing window gates.	20
Fig. A-4.	Hardware buffer and data channel control.	21
Fig. A-5.	Camera simulator signals.	24

1. INTRODUCTION

Active and passive infrared techniques are useful to detect and locate man-made objects in natural terrain. This report will describe a system capable of collecting quantitative background and signature data in the 8-12 μ m atmospheric window region. This system features real time digitization using conventional techniques to record data generated by an AGA 680 LW camera directly on a 9 track digital magnetic tape using a mini-computer as an intermediate storage buffer.

The majority of the existing and proposed digitization methods fall into three general categories:

1. Calibrated film recording
2. Analog magnetic tape recording
3. Direct digital recording

The first two methods require an intermediate analog storage mechanism and post-experiment digitization at non-real-time rates; these techniques are presented schematically in Figures 1-1a and 1-1b. The film recording method has the advantages of simplicity and economy for those laboratories with ready access to a microdensitometer. However, in many respects this is the least desirable of the three alternatives owing to the inherent non-linearity and low information density of photographic film or plates. Magnetic analog tape recording systems eliminate these problems, but still require two separate steps to produce a computer compatible digital tape.

Figure 1-1c illustrates the direct digitization approach. The infrared camera video is digitized in real-time by fast A/D converters and transferred

18-5-7196-1

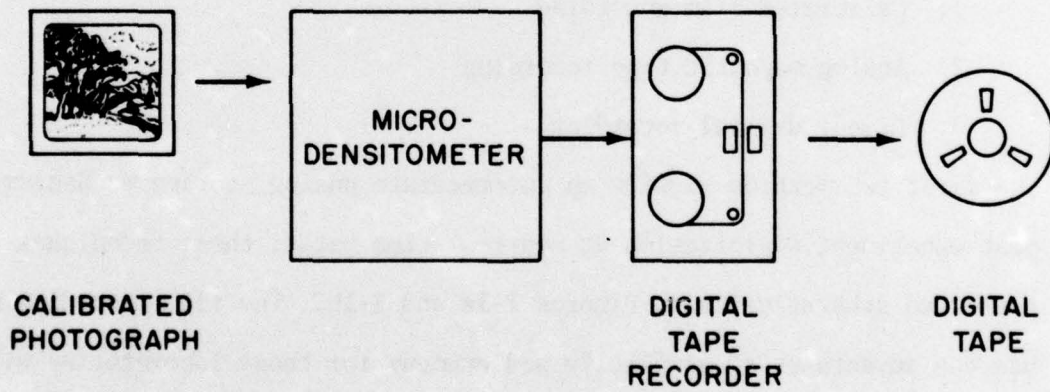
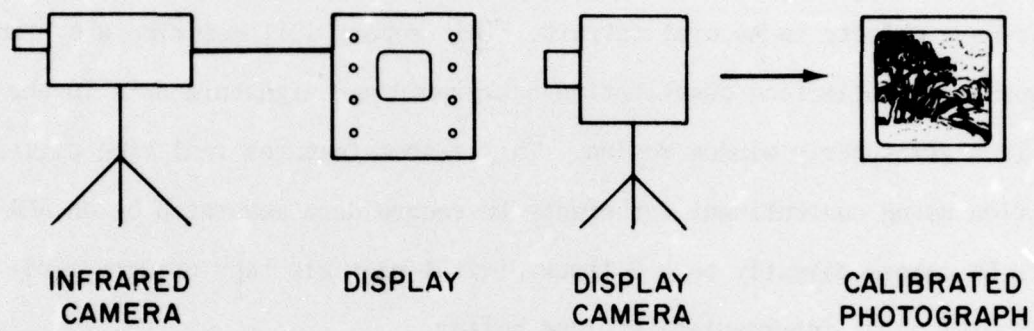

Fig. 1-1a. Film recording method.

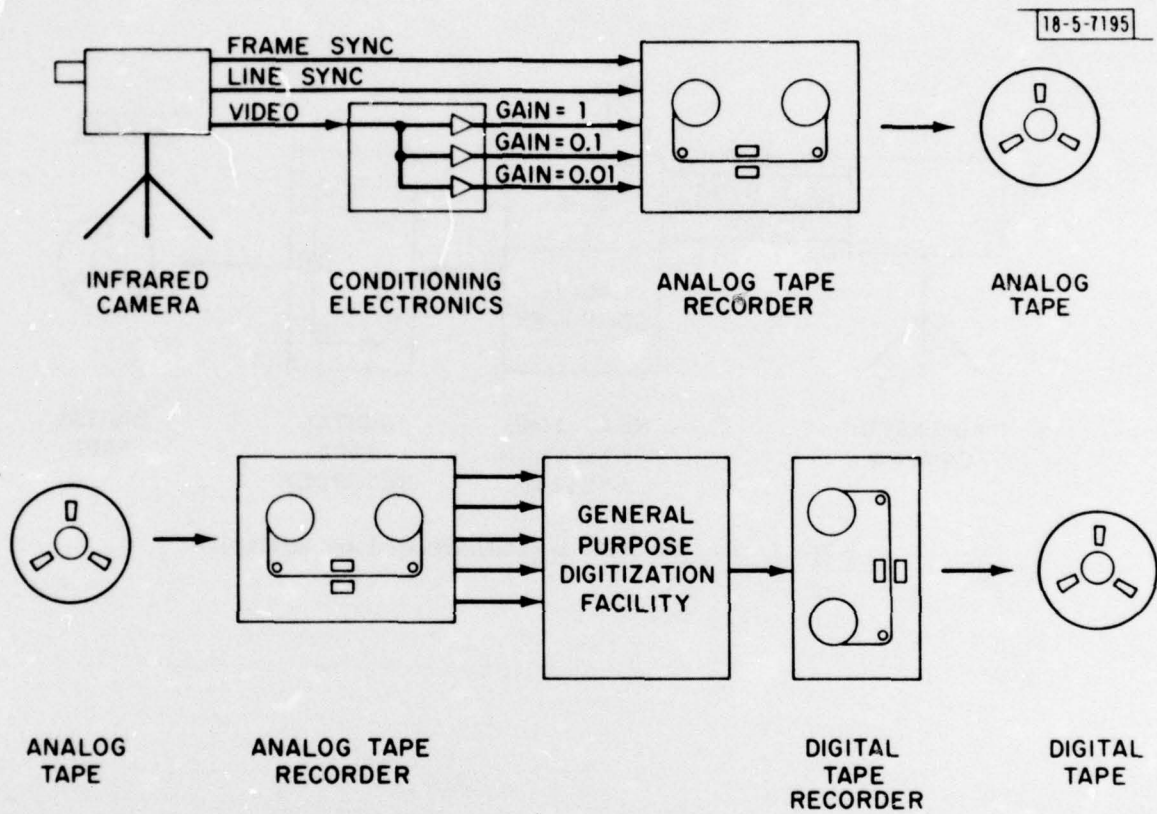

Fig. 1-1b. Analog recording method.

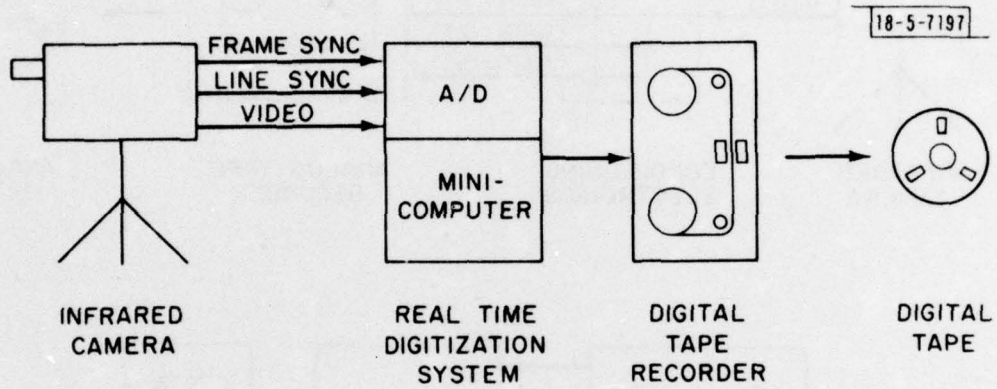

Fig. 1-1c. Direct digital recording method.

directly to standard 9 track digital tape, thus eliminating the need for duplicate analog tape recorders at field sites and in the laboratory. A key advantage of this system is the capability of instant data playback and analysis which is often vital in non-repeatable experimental situations.

2. EQUIPMENT

The real-time infrared data collection system is pictured in Figure 2-1. It consists of five major components:

1. An AGA 680 LW camera operating in the 8-12 μ m spectral waveband. This device has an 8^o x 8^o lens with a 1.3 mr instantaneous field of view. The noise equivalent temperature of this unit is less than 0.2^oC.

2. An analog to digital interface package containing a 1 μ s 8 bit A/D converter, a 16 bit hardware output buffer, and data clocking circuitry which generates 2,738 sixteen bit words during each camera frame.

3. A Data General NOVA 2/10 minicomputer with a 32,000 word memory. This device has a 16 bit parallel I/O central processor with a high speed direct memory access channel capable of transferring in excess of 500,000 words per second.

4. A Datum formatter-controller which converts the 16 bit NOVA words to standard 8 bit IBM tape format.

5. A Wangco 9 track digital tape recorder operating at 1600 BPI density at 75 IPS. The maximum writing speed of this recorder is 120,000 eight bit words per second under continuous data transfer conditions.

Interaction with the NOVA computer for post-experiment data review

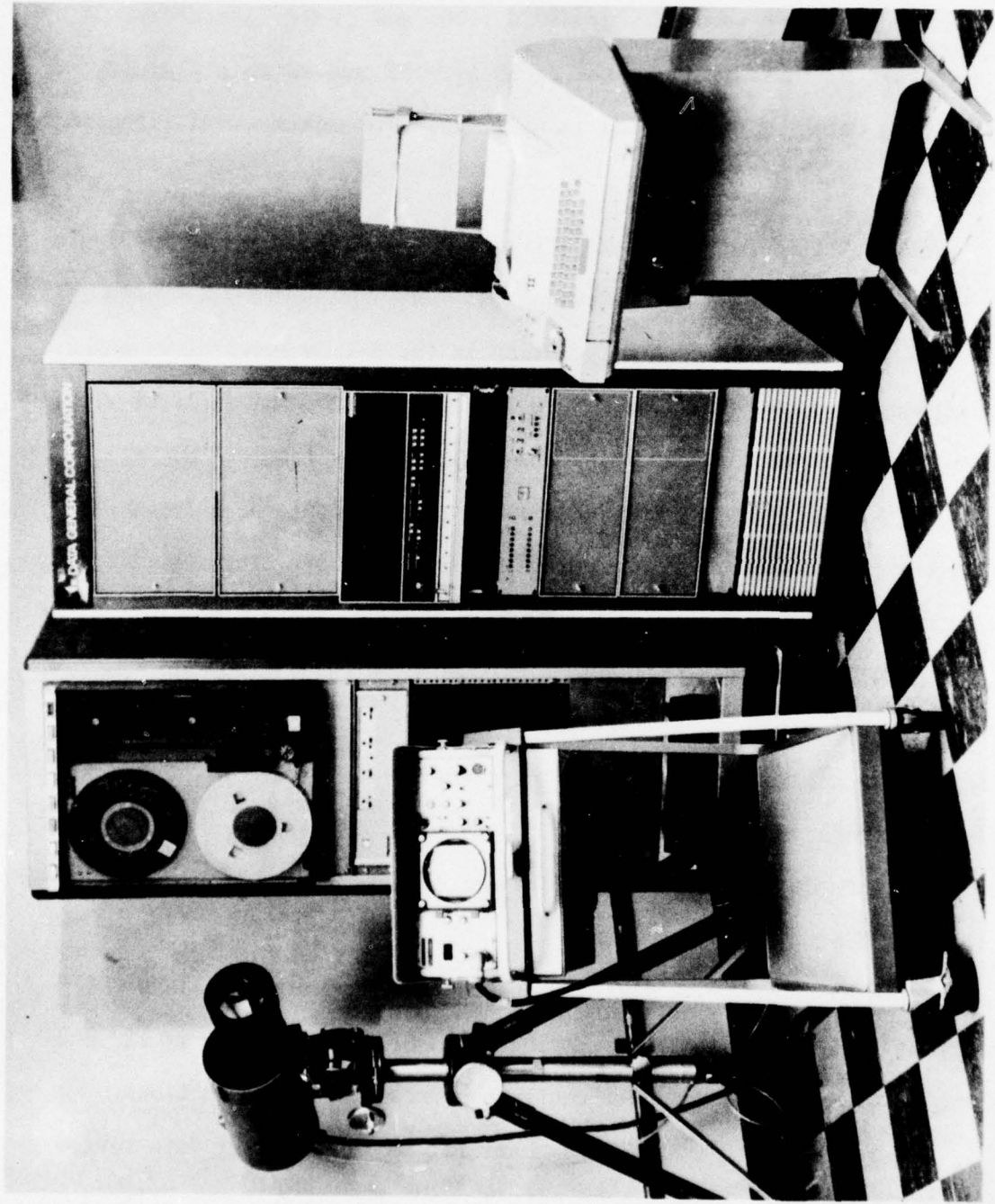

Fig. 2-1. Real time digital recording system.

and analysis is achieved through the use of a Teletype unit which is also shown in this figure. In addition to numerical output, crude gray scale pictures can be generated by the Teletype which can be compared with the AGA analog display for immediate conformation of proper system operation.

3. DATA RECORDING TECHNIQUE

The inherent spatial resolution of the AGA 680 camera yields a 100 x 100 picture element field for a total of 10,000 discrete data points. However only 74 lines are generated by each frame; a complete infrared picture requires at least two or three interlaced scans out of a full 7 frame field^{*}. The simplest and most direct method of digitizing these data involves a 74 x 74 sampling each frame, producing a 5476 discrete element field with 1.9 mr resolution.

The collection of 74 data points during a 425 μ s line scan is equivalent to an instantaneous sampling rate in excess of 175 kHz. While 8 bit word length transfer speeds up to 1 MHz can be obtained with conventional A/D converters and minicomputers, most commercial tape drive units are able to record less than 100,000 words/second under optimal conditions. The key element of this real-time digitization method is the use of a dedicated minicomputer to serve as a temporary storage buffer between the camera and the digital tape recorder. The computer is capable of storing bursts of data at the 175 kHz digitization rate while simultaneously outputting a uniform flow of data to the tape transport. Since the total time between frames is roughly twice that allotted to the active scan periods (a total of 31.05 ms is lost during the line and frame retrace periods), the average

^{*}D. Dorratcague, "Thermovision Digital Data Processing," Proceedings of the Second Biennial Infrared Information Exchange, St. Louis, Missouri. 27-29 August 1974.

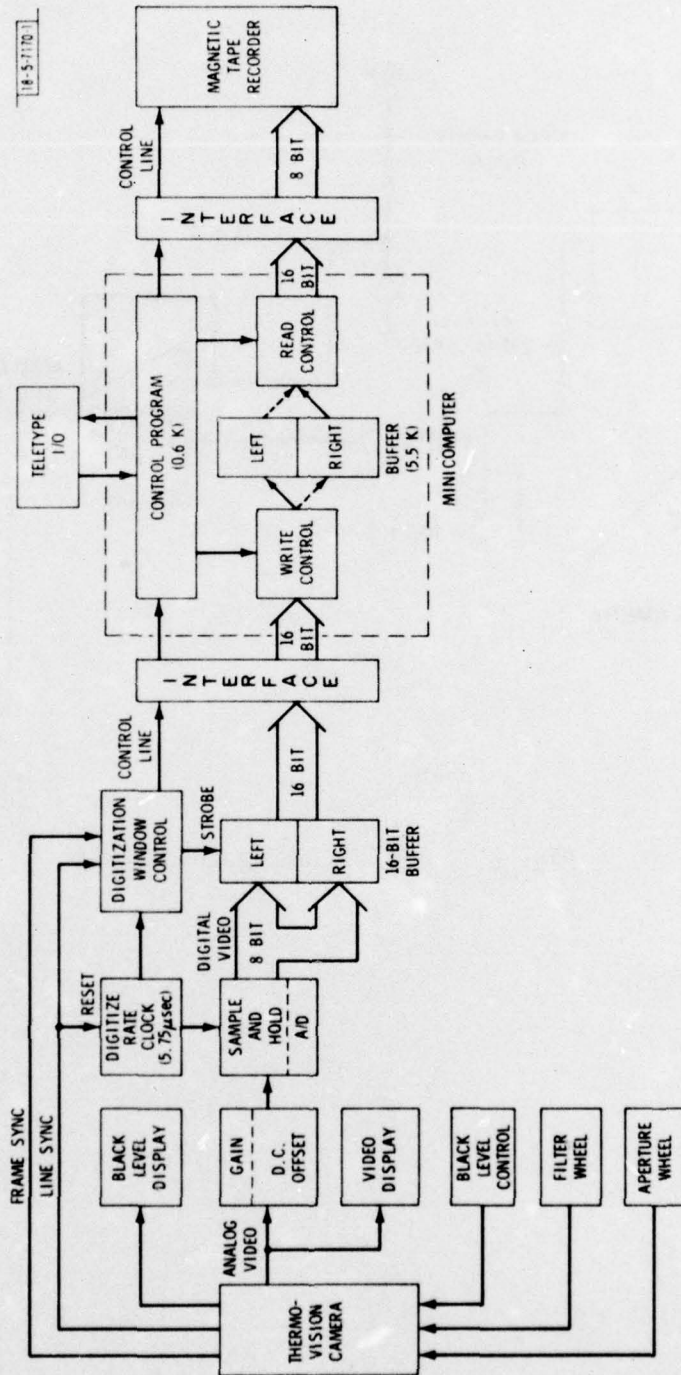

Fig. 3-1. Hardware flow chart.

data output rate is only 88 kHz which is well within the capability of several moderately priced digital tape units now available.

Figure 3-1 is a functional block diagram of the real-time recording system pictured in Figure 2-1. Video signals taken from the camera accessory plug are conditioned prior to recording by adjustment of the picture black level to produce a normal image on the AGA analog display. The signal then passes through the offset and gain circuit shown in Figure 3-2 which places it within the input range of the 8 bit analog to digital converter. The circuit gain is designed to match the digital step size to the noise equivalent temperature of the infrared system, resulting in a 50°C dynamic range with 0.2°C temperature resolution.

A 16 bit hardware buffer follows the A/D converter allowing temporary storage of two 8 bit words for subsequent transfer to the 16 bit word length NOVA memory. The timing circuit described in Figure 3-3 receives the line and frame sync pulses from the AGA 680 unit and generates time gates regulating the flow of digitized information from the hardware interface to computer core memory during the camera's active scan period.

Computer input and output is handled by a high speed data channel which takes first priority in a control hierarchy which is shown in Figure 3-4. A data channel request generated either by the A/D interface or the magnetic tape drive controller momentarily halts all computer operations guaranteeing uninterrupted information transfer. A low priority software program continuously performs routine functions such as resetting flags and counters; its main task is the switching of the read and write

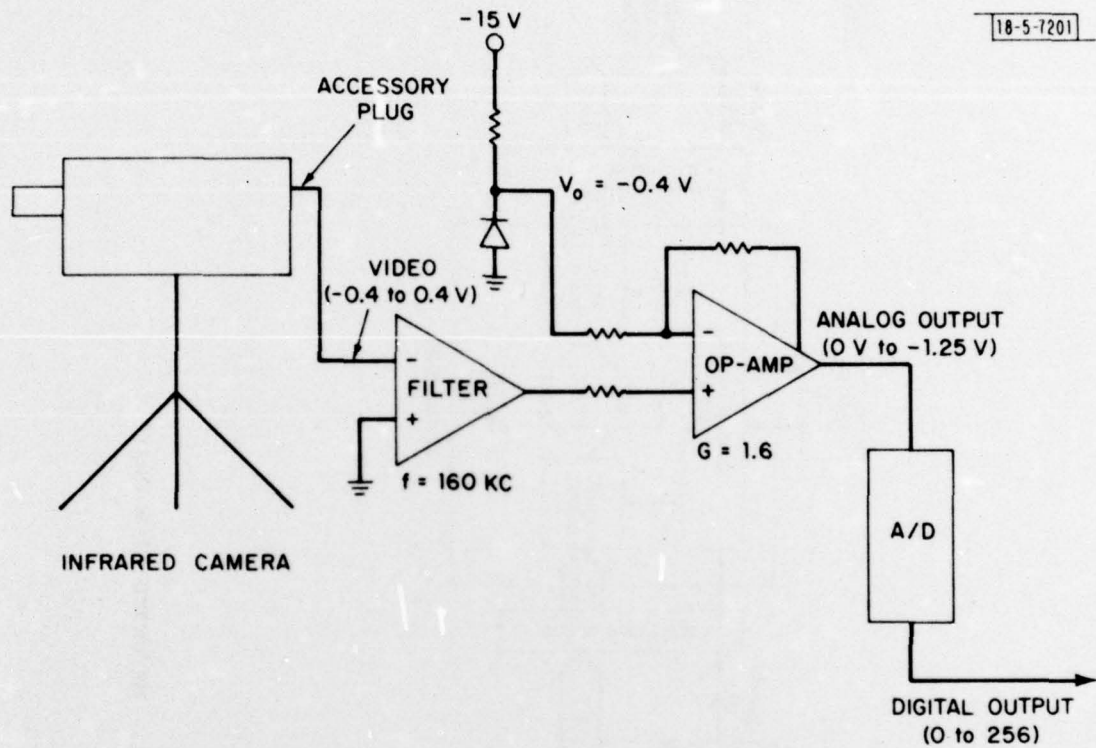

Fig. 3-2. Offset and gain circuit.

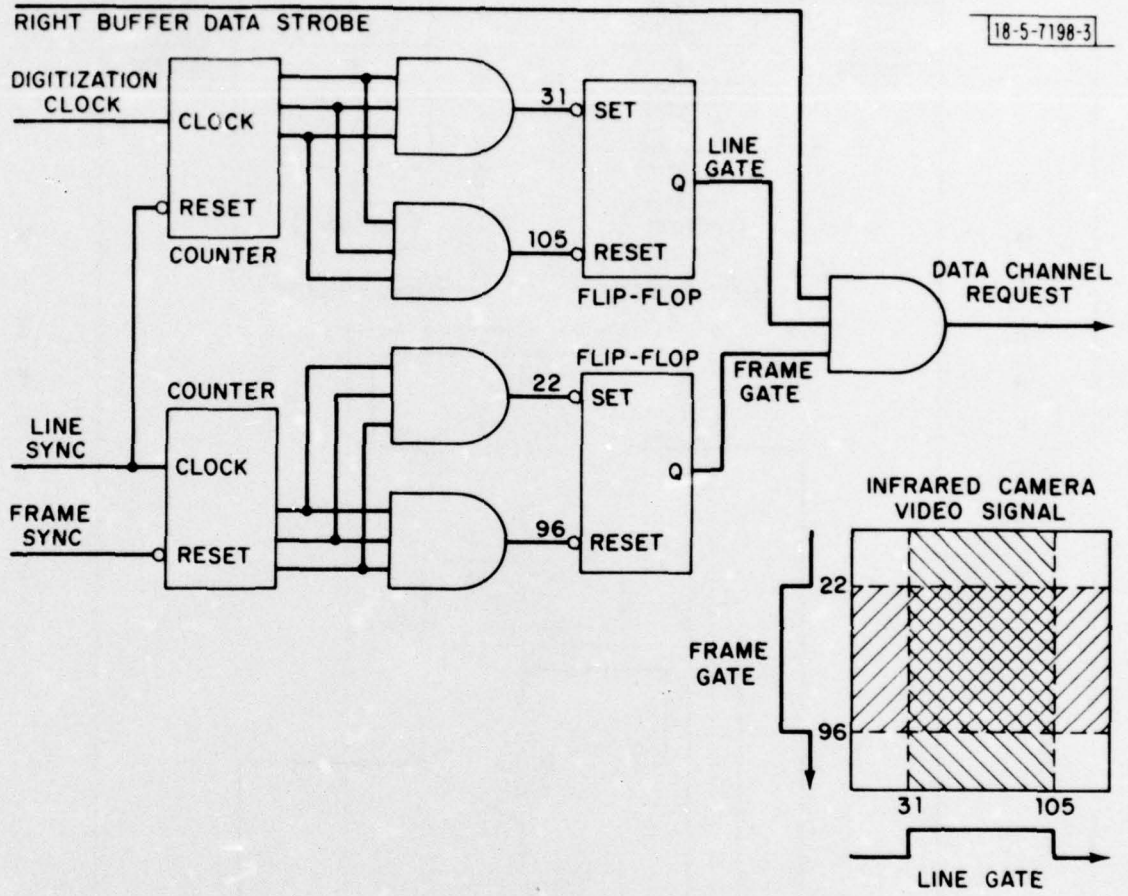

Fig. 3-3. Digitization window circuit.

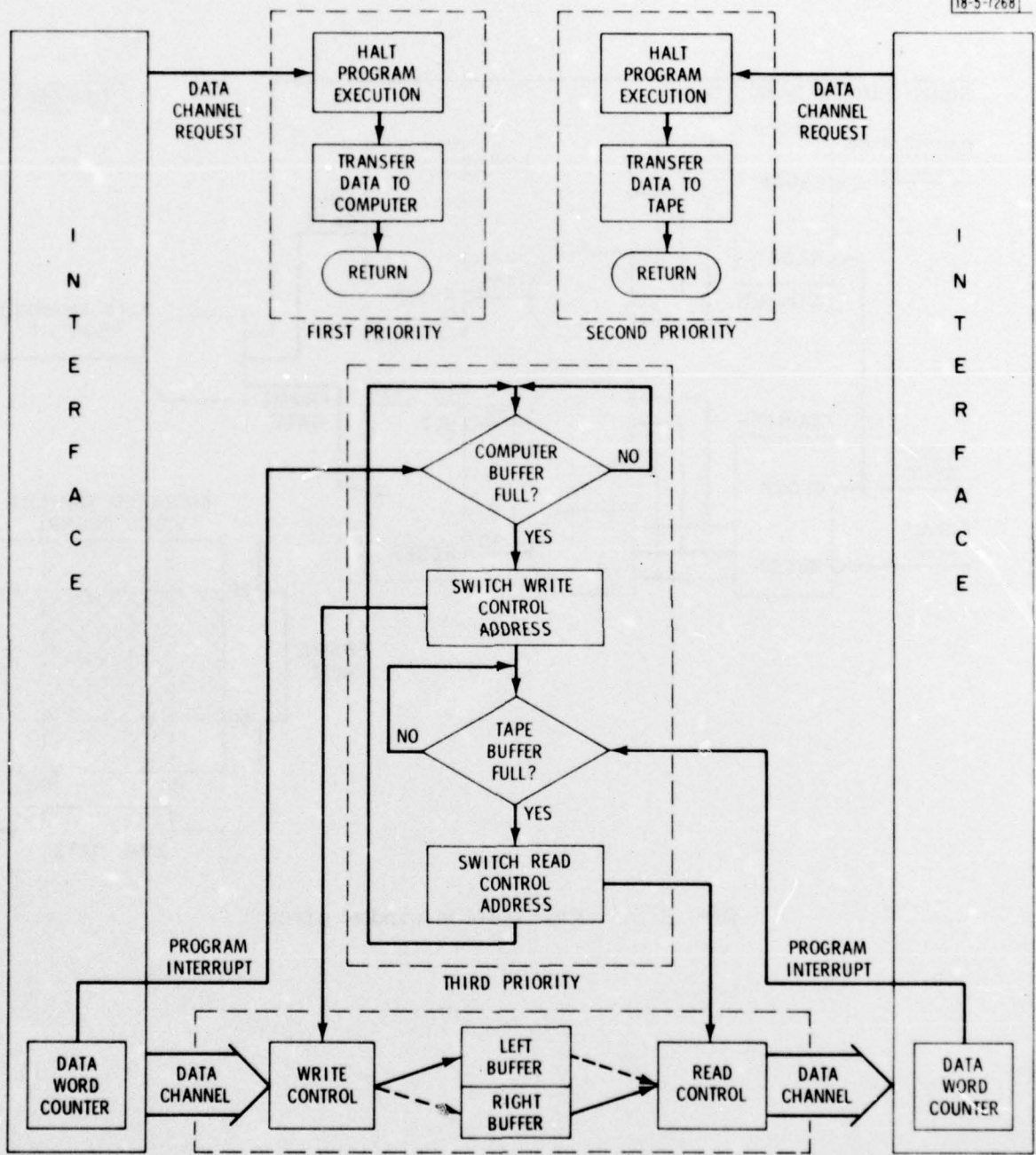

Fig. 3-4. Software flow chart.

buffer addresses when program interrupts signal that these functions have been completed. A total of 600 words of software memory is allocated to these control algorithms.

Two software buffers, each capable of storing a single frame of AGA data and occupying a total of 5500 words of NOVA memory, form the core of the real-time digital recording system. Data are written onto one memory block during the active scan period of the infrared camera while, simultaneously, the previous frame is read by the magnetic tape unit. Thus, data transfer to tape lags the camera video signal by a full frame, proceeding at an uninterrupted average rate of 87,616 eight bit words per second. Conversion of the NOVA 16 bit words to tape compatible 8 bit format is performed in the computer output interface by a commercially available formatter-controller.

4. SYSTEM PERFORMANCE

The performance of the real-time digitization system can be summarized by the following list:

1. $8^{\circ} \times 8^{\circ}$ field of view.
2. 1.9 mr instantaneous field of view.
3. 74 x 74 data format.
4. 16 frame per second data rate.
5. 265 digital step precision (48 dB S/N) giving a 50°C temperature dynamic range with 0.2°C resolution.
6. 9600 frame storage capacity allowing 10 minutes of continuous recording on a single 10 inch digital tape.

As indicated earlier, the inherent resolution of the AGA camera equipped with an 8° lens is approximately 1.3 mr, while the 74 x 74 digitization format results in a 1.9 mr picture element cell size. However the full camera resolution can be recovered at the expense of a lower output frame rate. Since the use of the minicomputer as an intermediate storage buffer removes the tape unit writing speed limitation, much larger data fields can be recorded as long as the average transfer rate is held below 100,000 words per second. Because of this, the present system could be easily modified to sample more frequently across each scan line and to make use of the camera interlace pattern to record 140 x 140 picture element fields at a rate of 4 fields per second.

5. CONCLUSIONS

A direct, real time digitization system has been developed for the AGA 680 camera which records 16 frames per second with a 74 x 74 data point format onto a standard 9 track digital tape. In its present configuration the recording capability is roughly comparable to that of an 80 kHz analog recorder, but offers the added advantages of providing the user with immediate post experiment data analysis. The most serious drawbacks of the present direct digitization system are its physical size and power requirements; this rack-mounted unit weighs over 250 lbs and its 2 kW power consumption is 10 times that of a portable analog recorder. However, it must be emphasized that this is a prototype system which was built entirely with off-the-shelf, general purpose laboratory components. It is expected that advances in microprocessor and tape transport technology will make it

possible to construct a rugged, lightweight, direct digitization unit in the very near future.

APPENDIX

Theory of Operation

Digitize Rate Clock

As shown in Figure A-1 the 5.75 μ s clock is generated by dividing down a seven stage counter from a 16MHz crystal oscillator. The four bit binary counters are 74163's which are fully synchronous. The synchronous clear allows decoding using one NAND gate. The selected outputs of the counters are fed through the NAND gate to produce a count of 91 and this in turn is used to reset the counters on the next clock pulse. The counters are also reset at the beginning of each horizontal scan line which guarantees the first 5.75 μ s pulse starts at the same time along each line.

Sample, Hold & A/D Converter

The 5.75 μ s clock is fed into a dual 9602 "one shot" to produce a delay of 1.5 μ s which is then fed to the Sample and Hold (S/H) command input to either sample or hold the video data for conversion by the analog to digital (A/D) converter. This circuit is given in Figure A-2. Since the S/H has an acquisition and setting time of approximately 1 μ s the A/D will start converting after the S/H has settled. The clock for the A/D is generated from the second half of the 9602. The A/D is in a free running mode, that is, the computer is not gating the A/D converter under software control. When the End of Conversion (EOC) goes low, the data from the A/D are valid and are presented to the data buffer on the computer input/output I/O board.

18-5-72(1)

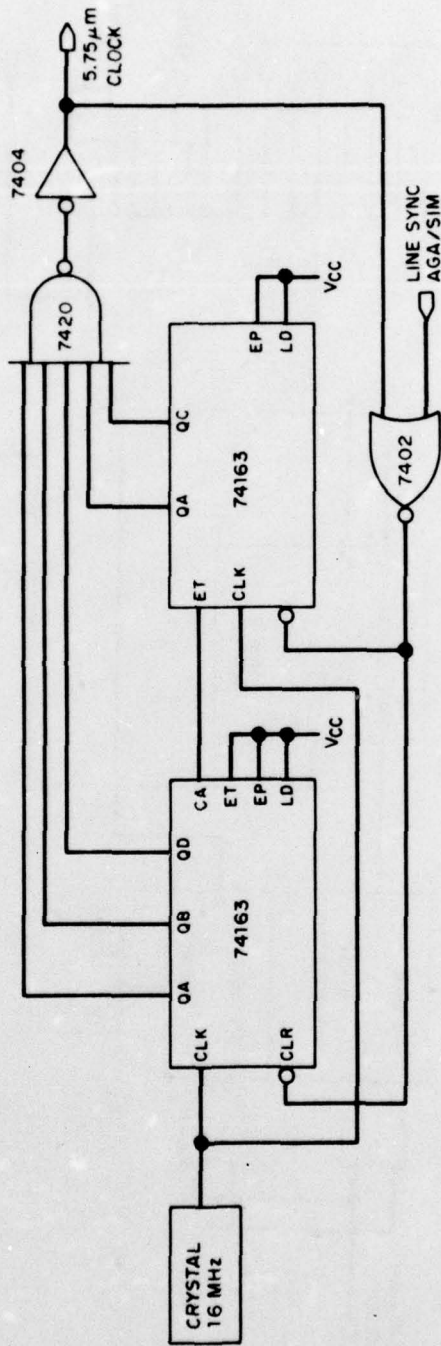

Fig. A-1. 5.75µs clock.

118-5-7273

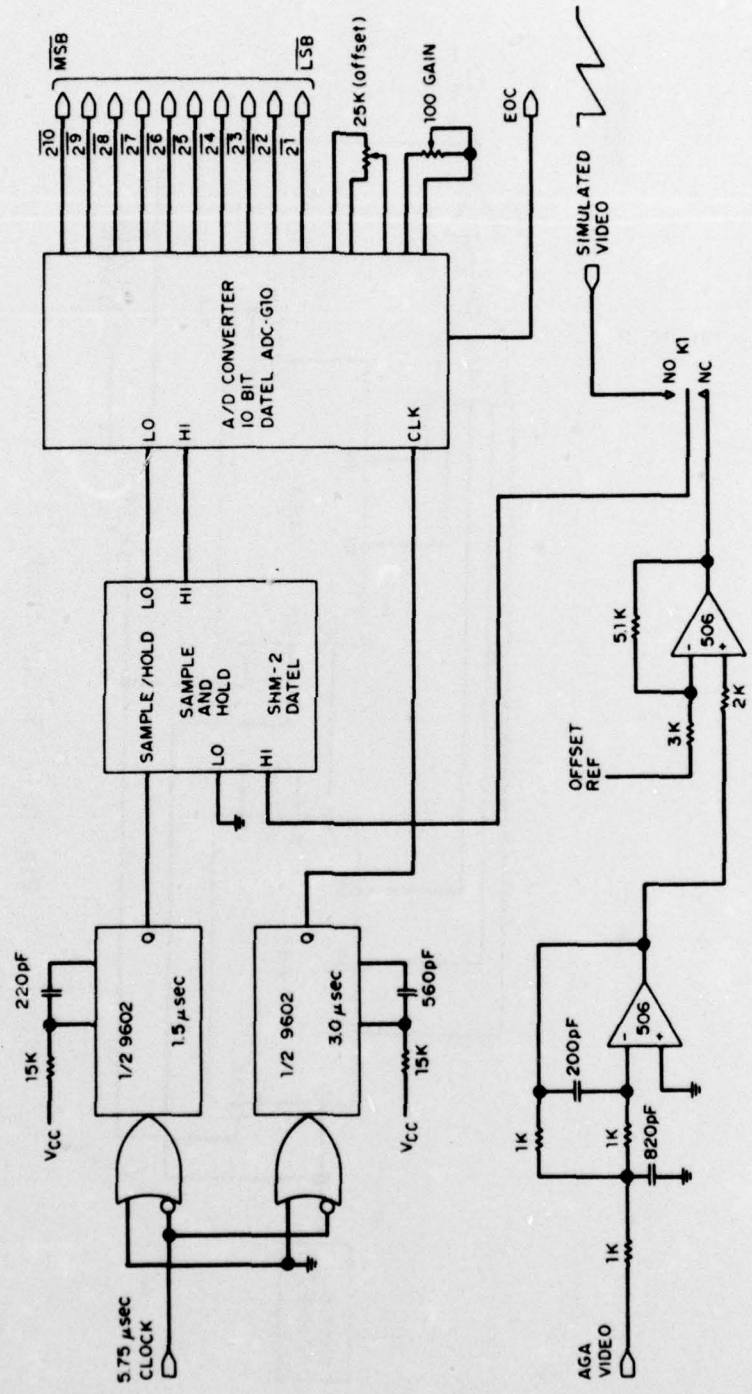

Fig. A-2. Sample/hold and analog/digital converter.

Digitization Window Control

In Figure A-3 the $5.75\mu\text{s}$ clock is used as an input to a counter which generates the line gate. There are 108 individual pulses across each $625\mu\text{s}$ horizontal scan line with the line gate window (digitizing area) being controlled by 2 binary counters, 2 NAND gates and 1 Flip Flop (F/F). One NAND gate turns on at a count of 31 and sets the F/F to a 1 state. This remains high until the second NAND gate is activated and resets the F/F to a zero state at a count of 105. The same technique is used to turn the frame gate signal on at the count of 22 horizontal scans and off at 96. The line and frame sync signals from the camera or simulator are used to reset their respective counters at the start of each scan.

Left/Right Buffer

Figure A-4 illustrates the 16 bit buffer and logic circuitry which controls data transfer to the computer. The line sync resets the Q output of a 7474 F/F to a zero state at the beginning of each horizontal line. The first EOC clocks the Q output to a one state and strobes the first eight bits of data into the left half of the data buffer. On the second EOC the F/F toggles and the \bar{Q} output goes high allowing data to be strobed into the right half of the buffer. This left/right strobing continues until the line sync resets the F/F and continues for the next horizontal line. This portion of the circuitry is always active and is not dependent on the computer program. The data are always available on the computer bus lines. The 2^9 and 2^{10} bits are used to detect overflow of the data since they go

10-5-7213

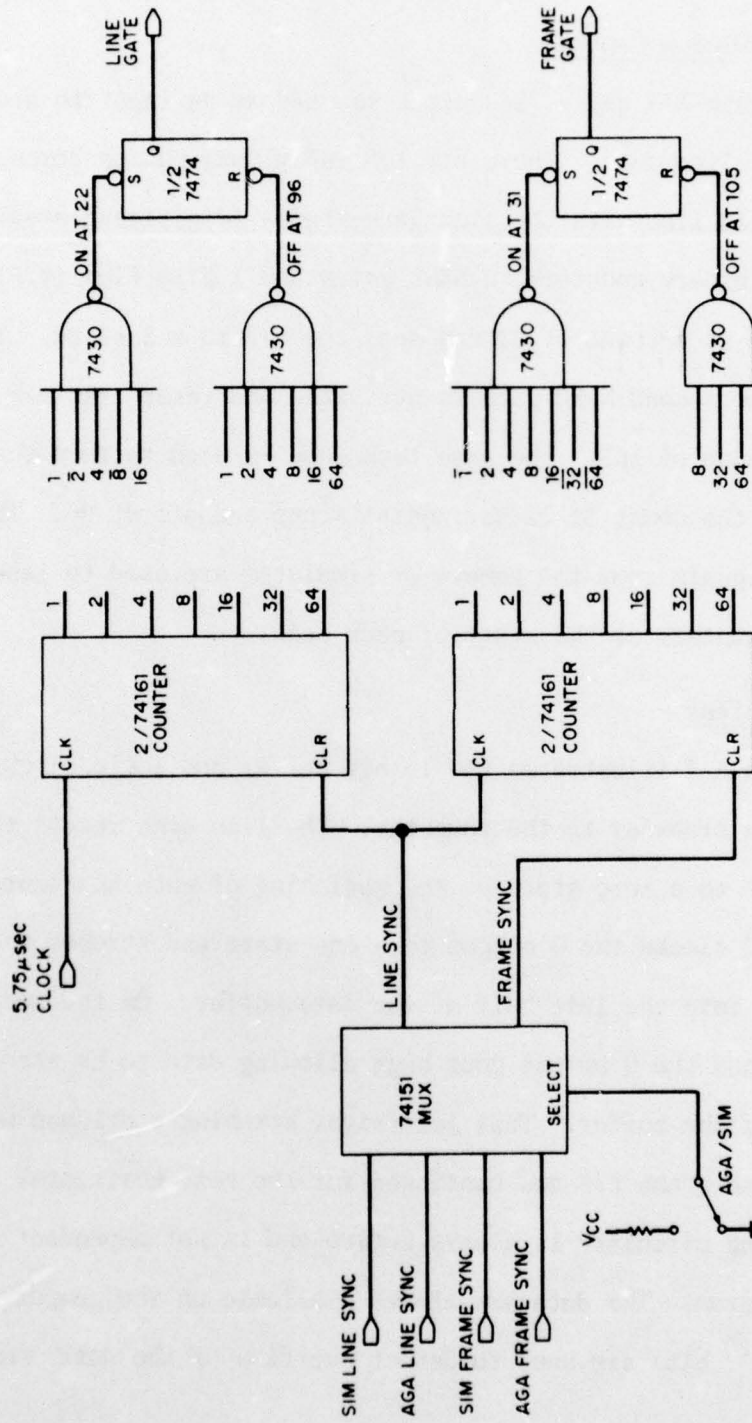

Fig. A-3. Digitizing window gates.

high only when saturation occurs. The A/D busy is set to the one state by the A/D start computer subroutine. On the next frame sync the 7474 Q output will go to a one state which guarantees that the data will be at the start of a frame and in sync with the program when the computer program is initiated. The data in the buffers are transferred to computer memory when the following conditions are met:

1. A/D busy is 1,
2. data are within the window area (controlled by the line and frame gates), and
3. data have been strobed into the right half of the data buffer.

The data are transferred to core memory using the direct memory access channel.

Data Channel

A word counter and memory address counter are needed to transfer data by Direct Memory Access (DMA). At the initiation of transmission, the word counter is loaded with the negative of the data block word count. Each time a word is transferred the counter is incremented by 1. When the counter overflows, the data channel transfers are terminated.

The memory address counter contains the address in memory which is to be used for the next data transfer. It is loaded by the computer program with the address of the first word in the block to be transferred. After each transmission, the memory address counter is incremented.

When the A/D has a word of data ready to be transferred to memory it issues a data channel request to the processor. The processor pauses as

soon as it has finished the last instruction and begins the data cycle by acknowledging the A/D's data channel request. The acknowledgment signal causes the A/D to send back to the processor the address of the memory location involved in the transfer. The memory address counter and word counter are then incremented by 1. When the word count becomes 0 the A/D Busy Flag is reset to 0 requesting an interrupt and the A/D Done Flag is set to a 1 terminating Data Channel transmission.

Camera Simulator

Figure A-5 shows the schematic for the camera simulator which is used to debug the hardware and software. Since the camera has the horizontal and vertical prisms operating in asynchronous mode, two separate 1 MHz crystal oscillators are used to generate both the line and frame sync signals. The line sync is derived by dividing down a 9 stage counter, producing a clock period of $625\mu\text{s}$ per line. A 9602 "one shot" increases the pulse duration by $7.2\mu\text{s}$ to simulate the line scan flyback time.

The frame sync circuitry is essentially the same as that of the line sync except that the $625\mu\text{s}$ clock is further divided down by 100 to produce a pulse duration of 62.5 ms. A 9602 "one shot" is used to increase the pulse duration by 5.6 ms to simulate the frame flyback time.

ACKNOWLEDGMENT

We are indebted to Mr. Harvey Buss for the development of the data display algorithms used to verify the operation of the real time digitization system.

UNCLASSIFIED

14 TT-18

SECURITY CLASSIFICATION OF THIS PAGE (When Data Entered)

REPORT DOCUMENTATION PAGE		READ INSTRUCTIONS BEFORE COMPLETING FORM
1. REPORT NUMBER 18 ESD-TR-77-56	2. GOVT ACCESSION NO.	3. RECIPIENT'S CATALOG NUMBER
4. TITLE (and Subtitle) 6 Real Time Digital Recording of Thermovision Data,	5. TYPE OF REPORT & PERIOD COVERED 9 Project Report	
	6. PERFORMING ORG. REPORT NUMBER Project Report TT-18	
7. AUTHOR(s) 10 Ronald J. Cordova Ronald R. Parenti	8. CONTRACT OR GRANT NUMBER(s) 15 F19628-76-C-0002 ARPA Order-2752	
9. PERFORMING ORGANIZATION NAME AND ADDRESS Lincoln Laboratory, M.I.T. P.O. Box 73 Lexington, MA 02173	10. PROGRAM ELEMENT, PROJECT, TASK AREA & WORK UNIT NUMBERS ARPA Order 2752 Program Element No. 62702E 16 Project No. 7G10	
11. CONTROLLING OFFICE NAME AND ADDRESS Defense Advanced Research Projects Agency 1400 Wilson Boulevard Arlington, VA 22209	12. REPORT DATE 11 2 Mar 77	
	13. NUMBER OF PAGES 12 32 p.	
14. MONITORING AGENCY NAME & ADDRESS (if different from Controlling Office) Electronic Systems Division Hanscom AFB Bedford, MA 01731	15. SECURITY CLASS. (of this report) Unclassified	
	15a. DECLASSIFICATION DOWNGRADING SCHEDULE	
16. DISTRIBUTION STATEMENT (of this Report) Approved for public release; distribution unlimited.		
17. DISTRIBUTION STATEMENT (of the abstract entered in Block 20, if different from Report)		
18. SUPPLEMENTARY NOTES None		
19. KEY WORDS (Continue on reverse side if necessary and identify by block number) digital recording thermal imagery NOVA computer analog recording direct digitization formatter-controller		
20. ABSTRACT (Continue on reverse side if necessary and identify by block number) A direct, real time, video to digital data recording system has been developed to record 10 ^{micrometers} thermal imagery in conjunction with an AGA 680 LW camera. This device is now being used to study the thermal characteristics of various types of natural terrain for the purpose of developing tactical target acquisition techniques. This data recording system consists of an analog to digital interface, NOVA 2/10 minicomputer, and magnetic tape transport and is designed to record 16 frames per second at a 175 kHz instantaneous digitization rate with 8 bit precision. Computer controlled timing circuits group pairs of 8 bit data words into a single 16 bit NOVA compatible word in an intermediate buffer which is then transferred into core memory. The minicomputer stores complete frames of data during the active camera scan period while simultaneously maintaining a constant 88,000 word/second transfer rate to the 9 track magnetic tape unit. The final data format consists of a 74 x 74 picture element array with 0.2°C temperature resolution and 50°C dynamic range.		

207 650 T