

AD-A040 213

AIR FORCE CIVIL ENGINEERING CENTER TYNDALL AFB FLA
EVALUATION OF REVERSE OSMOSIS FOR ELECTROPLATING WASTES.(U)
DEC 76 D H ALLEN, E C FREIN
AFCEC-TR-76-42

F/G 13/2

UNCLASSIFIED

NL

1 OF 1
ADA
040213

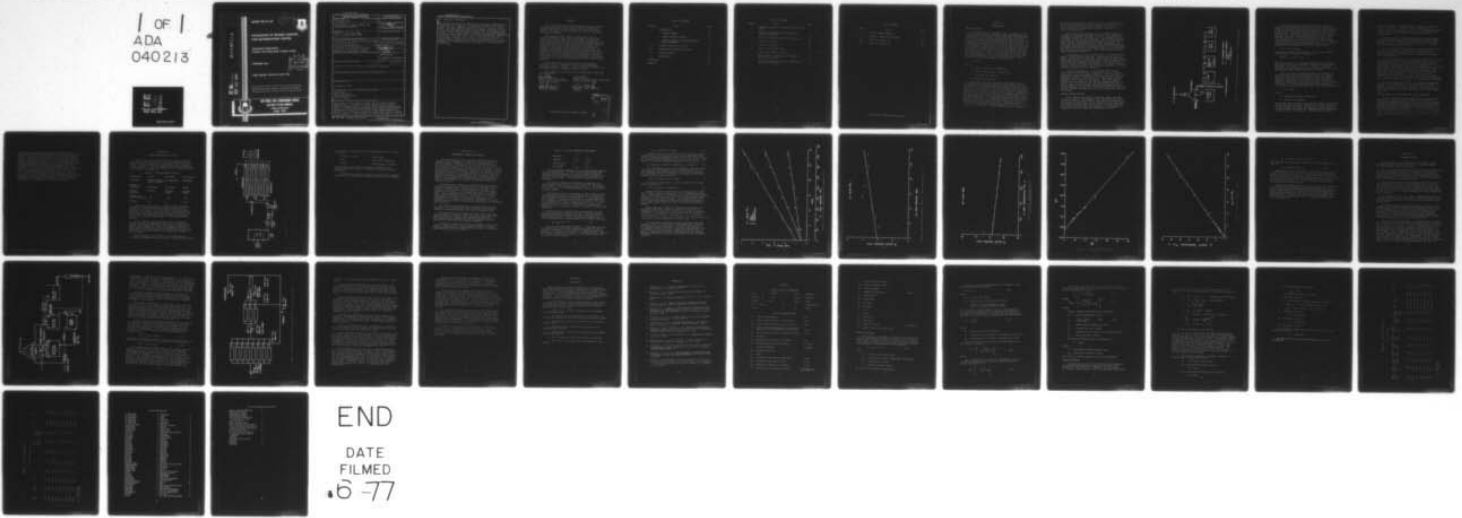

END

DATE
FILMED
16-77

BR



AFCEC-TR-76-42

ADA 040213

**EVALUATION OF REVERSE OSMOSIS
FOR ELECTROPLATING WASTES**

ENVIRONICS DIRECTORATE
TYNDALL AIR FORCE BASE, FLORIDA 32403

DECEMBER 1976

DDC
RECEIVED
JUN 7 1977
W A

FINAL REPORT: JUNE 1974-JULY 1976

AD No. _____
DDC FILE COPY

Approved for public release; distribution unlimited.



AIR FORCE CIVIL ENGINEERING CENTER
(AIR FORCE SYSTEMS COMMAND)
TYNDALL AIR FORCE BASE
FLORIDA 32403

UNCLASSIFIED

SECURITY CLASSIFICATION OF THIS PAGE (When Data Entered)

REPORT DOCUMENTATION PAGE		READ INSTRUCTIONS BEFORE COMPLETING FORM
1. REPORT NUMBER AFCEC-TR-76-42	2. GOVT ACCESSION NO.	3. RECIPIENT'S CATALOG NUMBER
4. TITLE (and Subtitle) EVALUATION OF REVERSE OSMOSIS FOR ELECTROPLATING WASTES.		5. TYPE OF REPORT & PERIOD COVERED Final Report rept. 30 Jun 74 to 1 Jul 76
		6. PERFORMING ORG. REPORT NUMBER
7. AUTHOR(s) Dale H. Allen, 1Lt, USAF Emil C. Frein, Major, USAF		8. CONTRACT OR GRANT NUMBER(s)
9. PERFORMING ORGANIZATION NAME AND ADDRESS Water and Solid Waste Resources Division Air Force Civil Engineering Center (OLAA) Kirtland AFB NM 87117		10. PROGRAM ELEMENT, PROJECT, TASK AREA & WORK UNIT NUMBERS Program Element 63723F Job Order No. 21037W37
11. CONTROLLING OFFICE NAME AND ADDRESS Air Force Civil Engineering Center Environics Directorate (AFCEC/EV) Tyndall Air Force Base FL 32403		12. REPORT DATE December 1976
14. MONITORING AGENCY NAME & ADDRESS (if different from Controlling Office)		13. NUMBER OF PAGES 41 p.
		15. SECURITY CLASS. (of this report) UNCLASSIFIED
		15a. DECLASSIFICATION DOWNGRADING SCHEDULE
16. DISTRIBUTION STATEMENT (of this Report) <p style="text-align: center;">Approved for public release; distribution unlimited.</p>		
17. DISTRIBUTION STATEMENT (of the abstract entered in Block 20, if different from Report)		
18. SUPPLEMENTARY NOTES <p style="text-align: center;">Available in DDC.</p>		
19. KEY WORDS (Continue on reverse side if necessary and identify by block number) Environics Water Pollution Electroplating Wastes Reverse Osmosis		
20. ABSTRACT (Continue on reverse side if necessary and identify by block number) The purpose of this research effort was to evaluate Reverse Osmosis (RO) as a process to reduce pollution and increase materials conservation in large Air Force chrome plating operations. In these studies simulated chrome plating solutions were processed by an RO unit built to Air Force specifications by Envirex, Inc., Milwaukee, Wisconsin, using three types of commercial RO modules. In particular, this study was aimed at (cont'd)		

DD FORM 1 JAN 73 1473

EDITION OF 1 NOV 65 IS OBSOLETE

UNCLASSIFIED

SECURITY CLASSIFICATION OF THIS PAGE (When Data Entered)

340 985

UNCLASSIFIED

SECURITY CLASSIFICATION OF THIS PAGE(When Data Entered)

20. Abstract (concluded)

determining the degree of separation and membrane damage/deterioration when RO is applied to hexavalent chromium in an acidic medium (pH 6.5). Initial tests were made on a tubular, spiral wound, and Permasep (manufactured by duPont) membrane to determine which type membrane might be applicable to the chrome waste stream. Based on these initial studies, the Permasep membrane was chosen for further study. The Permasep membrane demonstrated a high salt rejection rate (0.96 to 0.99 reject ratio) and a high product recovery rate (0.59 to 0.70 recovery ratio). A closed system resulting in zero discharge of chromium from water emissions was designed based on the results of the Permasep membrane.

UNCLASSIFIED

SECURITY CLASSIFICATION OF THIS PAGE(When Data Entered)

PREFACE

This report documents work performed during the period 30 June 1974 through 1 July 1976 by the Air Force Civil Engineering Center (OLAA), Kirtland Air Force Base, New Mexico. Major Emil C. Frein and 1st Lt Dale H. Allen were the project officers.

The purpose of the research reported here was to evaluate Reverse Osmosis (RO) as a process to reduce pollution and increase materials conservation in large Air Force chrome plating operations. In these studies simulated chrome plating solutions were processed by a Reverse Osmosis unit built to Air Force specifications by Envirex Inc, Milwaukee, Wisconsin, using three types of commercial RO modules. The purpose was to evaluate recycling both the concentrated chromium solutions to the plating baths and the filtrate to the vent scrubbers and rinse tanks. The data from these studies are compared with theoretical relationships found in the literature and calculations are given for the design of a typical installation at an Air Force plating facility.

This report has been reviewed by the Information Office (OI) and is releasable to the National Technical Information Service (NTIS). At NTIS it will be available to the general public, including foreign nations.

This technical report has been reviewed and is approved for publication.

Emil C. Frein
EMIL C. FREIN, Maj, USAF
Chief, Water and Solid Waste
Resources Division

Robert E. Brandon
ROBERT E. BRANDON
Technical Director

Donald G. Silva
DONALD G. SILVA, Lt Col, USAF, BSC
Director of Environics

Robert M. Iten
ROBERT M. ITEN, Col, USAF
Commander

AGRESSION for	
NTIS	Write Section <input checked="" type="checkbox"/>
DDC	Offi Section <input type="checkbox"/>
ANNOUNCES	<input type="checkbox"/>
JUSTIFICATION	<input type="checkbox"/>
DISTRIBUTION/AVAILABILITY CODES	
REF.	AVAIL. REQ./SPECIAL

A

TABLE OF CONTENTS

Section	Title	Page
I	INTRODUCTION	1
	REVERSE OSMOSIS	1
	CHROME PLATING PROCESS	2
	REVERSE OSMOSIS FOR ELECTROPLATING WASTE TREATMENT	5
II	REVERSE OSMOSIS PILOT PLANT	7
III	EXPERIMENTAL DESIGN AND RESULTS	10
IV	PROPOSED DESIGN	19
V	CONCLUSIONS	25
	REFERENCES	26
	APPENDIX	27

LIST OF FIGURES

Figure	Title	Page
1	Schematic Diagram of Reverse Osmosis Pilot Plant	3
2	Chrome Plating Operations Resulting in Chromium Emissions	8
3	Plot of Flow Rates versus Feed Pressure	13
4	Plot of \hat{R} versus ΔP	14
5	Plot of \hat{R} versus C_f	15
6	Plot of $1/R^0$ versus $1/\Delta P$	16
7	Plot of C_p versus $C_m (1-R^0)$	17
8	Mass Balance on Chromium for Proposed Plating Line Design	20
9	Reverse Osmosis Pilot Plant Designed for Starting Conditions	22

LIST OF TABLES

Table	Title	Page
1	Reverse Osmosis Modules	7
2	Relative Membrane Performance	11
A-1	Data for Constant C_f	33
A-2	Data for Constant ΔP	34

SECTION I
INTRODUCTION

REVERSE OSMOSIS

The term osmosis is commonly used to describe the flow of water from a dilute solution through some membrane to a more concentrated solution. These membranes are frequently described as being semipermeable, which, theoretically, refers to a membrane which is permeable only to the solvent. If one starts with a pure solvent on one side of such a semipermeable membrane and a solution on the other side, the solvent (water in the case of an aqueous solution) will diffuse through the membrane until a certain osmotic pressure is reached, at which time the rate of diffusion across the membrane in each direction is in equilibrium and no further net flow occurs. In theory, if the membrane is ideal and truly semipermeable, and if the solutions are dilute, then the osmotic pressure is a function only of molar concentration and absolute temperature (Reference 1).

$$\pi^{\circ} = CRT \quad (1)$$

where:

π° = osmotic pressure (atmospheres)

C = solute concentration (moles/liter)

R = universal gas constant

T = absolute temperature

If pressure were applied to the concentrated side of the membrane, the amount of solvent which diffuses through the membrane to the concentrated side would decrease. Theoretically, application of the osmotic pressure determined by equation 1 will result in zero net flow across the membrane. Application of pressures greater than the osmotic pressure will result in flow of solvent from the concentrated solution to the dilute solution. This is known as reverse osmosis (RO). The application of RO to industrial scale operations depends upon the availability of a membrane which is not only semipermeable, but also capable of high solvent flux rates. Although such membranes do not exist, membranes with characteristics of high flux rates and high solute rejection rates are now available. These membranes, most of which are

constructed of cellulose acetate in various configurations, have been demonstrated to be applicable to the desalination of sea water and brackish water (References 2 and 3). Design equations as summarized by Weber (Reference 4) are given in the appendix.

The modules are constructed of the membrane material attached to a permeable support material. The simplest configuration consists of one tube. The feed solution enters the module at one end under pressure. As this feed solution flows down the inside of the tube, solvent (and some solute) passes through the membrane and becomes the product; the feed solution becoming continuously more concentrated until it emerges under slightly reduced pressure as the concentrate. The inside of this tube is generally referred to as the concentrate side of the membrane. The product solution emerges under negligible pressure.

A modification of this configuration is the hollow fiber module. These hollow fibers are connected at one end to a sheet which serves as a manifold. Feed solution enters the module through some type of distributor tube and passes around the hollow fiber membranes where some of the solvent (and solute) enters the fibers and emerges as the product through a type of manifold device. The remaining portion of the feed solution emerges as the concentrate.

Another configuration is the spiral wound module, which consists of sheets of a porous material put together between two layers of membrane material. This, in turn, is sandwiched between mesh spacers surrounded by two impervious layers of material. These layers are wound around a tube situated in the center of the module. Feed water passes through the mesh material and over the membrane surface where a dilute solution passes through the membrane and the porous material into the tube where it emerges at one end of the module as the product. The concentrated feed solution emerges through the mesh material to the concentrate part of the module.

CHROME PLATING PROCESS

Many different processes, solutions, tanks, and techniques are used in the operation of a chrome plating line. For the purposes of this report, only those processes which contribute to either water or air emissions of chromium will be isolated and analyzed (see Figure 1). Example data were taken from a study of the plating shop at the Oklahoma Air Logistics Center at Tinker AFB (References 5 and 6).

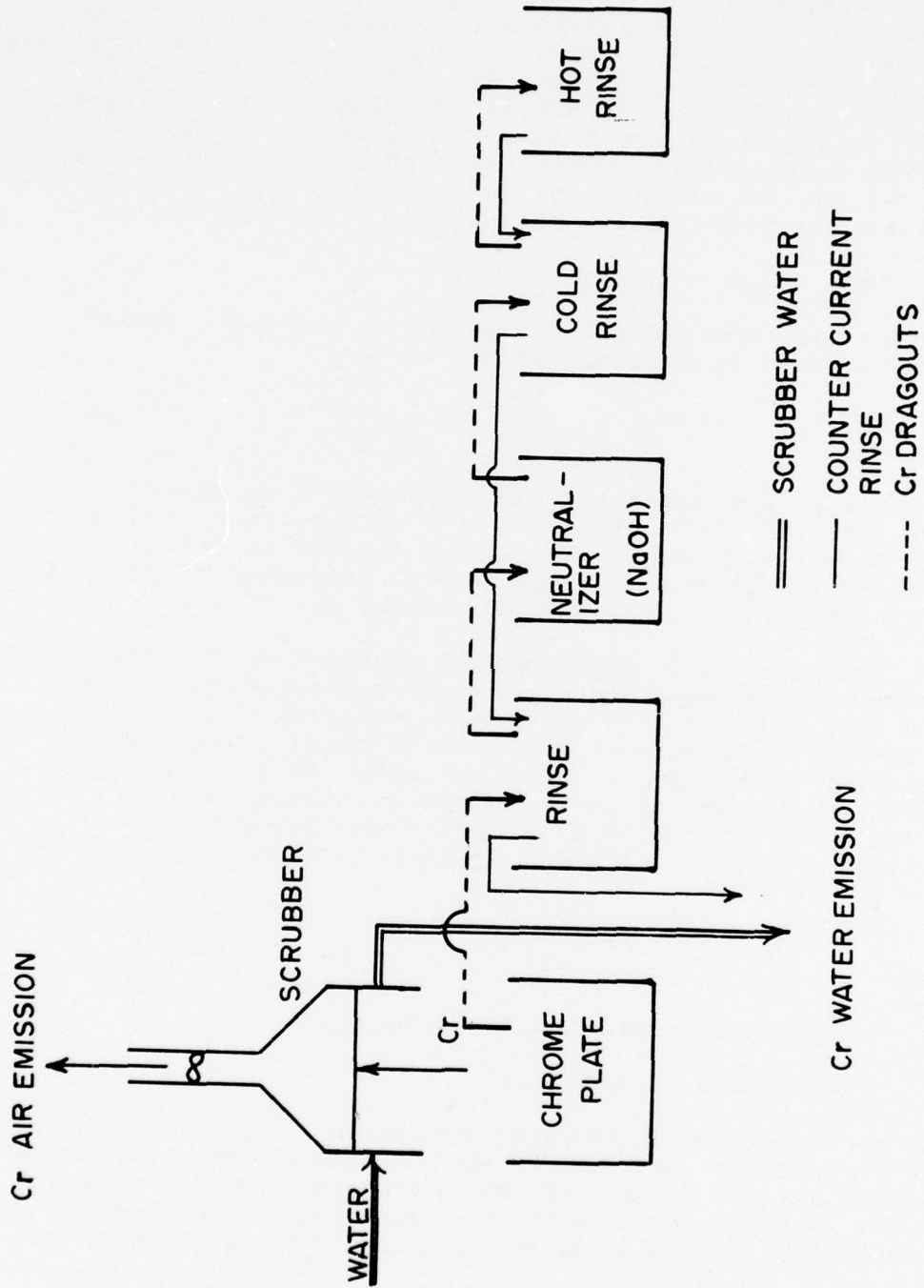
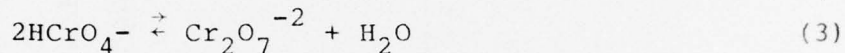

Figure 1. Chrome Plating Operations Resulting in Chromium Emissions

After being cleaned, etched, and rinsed, parts are placed in the chrome plate tank where they are plated at different amperages for different lengths of time, depending on the nature of the part and the thickness of the surface to be plated. Parts plated during the referenced study included sleeve bearings, turbine compressor hubs, internal bearings and other miscellaneous parts from jet engines. The bath consists of 33 oz/gal chromium trioxide (CrO_3) (2.48 moles/liter) and 0.33 oz/gal sulfuric acid (H_2SO_4) (0.0243 moles/liter), producing a pH of 0.5 to 1.0.² The concentrations are checked and adjusted weekly. The CrO_3 dissociates to form chromic acid (H_2CrO_3) (Reference 7):



Because the chromium concentration is high, the formation of dichromate is favored (Reference 8).



The part placed in the solution functions as the cathode where the reduction of hexavalent chromium supplied by the dichromate or chromate (Cr +6) is reduced to metallic chromium and plated onto the part. Evaporative losses from each plating tank averaged 400 liters per day.

This electrolytic mechanism causes the formation of minute bubbles which form a chromium containing aerosol when they burst at the surface of the tank. A similar source of chromium bearing aerosols results from the air agitation system used to mix the tank, thus preventing depletion stagnation of the plating solution in the vicinity of the part. Chromium emissions from this source were correlated with the current applied to each tank (Reference 5).

$$E = 10 + 120I$$

where:

E = chromium emission in gm Cr/day

I = current in kiloamps

The aerosol thus produced is exhausted through a collar duct which surrounds each tank. Most of the chromium contained in this aerosol is removed by impaction on a mat material in the scrubber mechanism; the remainder passes through and constitutes the air emissions. The chromium impacted on

this mat material is removed by water, forming a portion of the water emissions. Although water emissions from the scrubber averaged 20 mg/l as Cr, it has been demonstrated that concentrations of 1000 mg/l as Cr can be maintained in the scrubber water without affecting scrubber performance (Reference 6).

A second source of chromium containing water emissions results from dragout losses directly from the plating bath. Each part removed from the bath dragged out 10 ml of plating solution with it. (An average of nine parts were removed from all plating baths per hour).

One series of rinse tanks serves all seven plating baths on a line. At present, rinse baths 2 and 3 are counter current. The influent rinse water to rinse 1 and 3 is deionized water, the flow of which is controlled by conductivity measurements.

This arrangement could be modified so that all three rinse baths would be operated in a counter current mode, with deionized water as an influent to only the third rinse tank. Under such an arrangement, the 10 ml of dragout from the plating bath would become mixed with the solution in the first rinse tank, 10 ml of the solution in the first rinse tank would become mixed with the solution in the second rinse tank, etc. The flow rate of deionized water into the third rinse tank can be adjusted to maintain an acceptable chromium concentration in the third rinse tank (estimated to be 10 mg/l as Cr). The overflow from the first rinse tank would constitute the second source of chromium water emissions.

The neutralizer tank consists of a solution containing 8 oz/gal (1.51 moles/liter) of sodium hydroxide (NaOH). The purpose of this solution is to neutralize the pH of the dragout from the first rinse. When used, the dragout from this bath becomes the principal chromium input to the second rinse bath.

REVERSE OSMOSIS FOR ELECTROPLATING WASTE TREATMENT

Reverse Osmosis has been proposed for use with plating operations. Advantages claimed include the recycling of plating chemicals, recycling of rinse waters, minimal energy requirements compared with evaporation, elimination of sludge buildup, elimination of equipment associated with chemical destruction methods and the use of a closed loop system to meet EPA regulations (Reference 9). Systems which have been proposed involve the recycle of the concentrate back into the plating bath and reuse of the product water for the rinse tanks (References 10 and 11). Problems have been encountered or anticipated with chromic acid baths, however.

Golomb (Reference 11) determined that cellulose acetate membranes were attacked by unneutralized chromic acid rinses (pH 2, 6), but were not attacked by other acidic plating wastes. Donnelly et al (Reference 10) found that raising chromic acid rinses to pH 4.5 to 6.0 significantly extended the life of cellulose acetate and polyamide membranes, but did not determine the estimated life of the membranes, under these pH conditions. New types of membranes have been developed to treat metal finishing effluents, but these membranes were not found to be suitable for acidic oxidizing wastes, such as chromic acid wastes at pH 1.5 (Reference 12). Neutralized chromic acid wastes were not tested in this study. Golomb (Reference 13) has proposed that chromium chemicals resulting from RO treatment of chrome plating wastes could be economically reused by other industries, if unsuitable for recycling within the plating shop.

SECTION II

REVERSE OSMOSIS PILOT PLANT

The RO unit used in this study was custom fabricated specifically for this project. It contains three sets of three different membranes: hollow fiber, tubes, and spiral wound, arranged so that any combination of these membranes can be utilized in either parallel or series operation modes (See Figure 2 and Table 1).

TABLE 1. REVERSE OSMOSIS MODULES

Manufacturer:	DuPont	Gulf Atomic	Fluid Science
Brand Name:	Permaser Permeator Model No. 0420-018	Roga Model 4100	UOP OSMOTIK
Membrane Configuration	Hollow Fiber	Spiral Wound	Tubular
Membrane Material:	B-9 Fiber	Cellulose Acetate	Cellulose Acetate
Maximum Operating Pressure(psi):	400	800	600
pH range:	4-11	5-6	4.5-5.5

Solutions from a 378 liter (100 gal) feed tank pass through a 1/3 hp booster pump, which provides positive pressure on the inlet side of the high pressure pump and overcomes the pressure loss through the cartridge filters. These retain particles less than 5 microns and protect the RO modules. The multistage high pressure pump used was rated at 7½ hp and was constructed of stainless steel and plastic.

The RO modules listed in Table 1 are arranged and plumbed so that any combination can be run in parallel or series. The product flow rate is monitored by three rotometers before discharge. Under experimental conditions, both product and feed streams were recombined into the feed tank which had cooling coils for reducing heat buildup in the solutions.

The cleaning of RO membranes was accomplished by a procedure recommended by Envirex Inc. This procedure calls

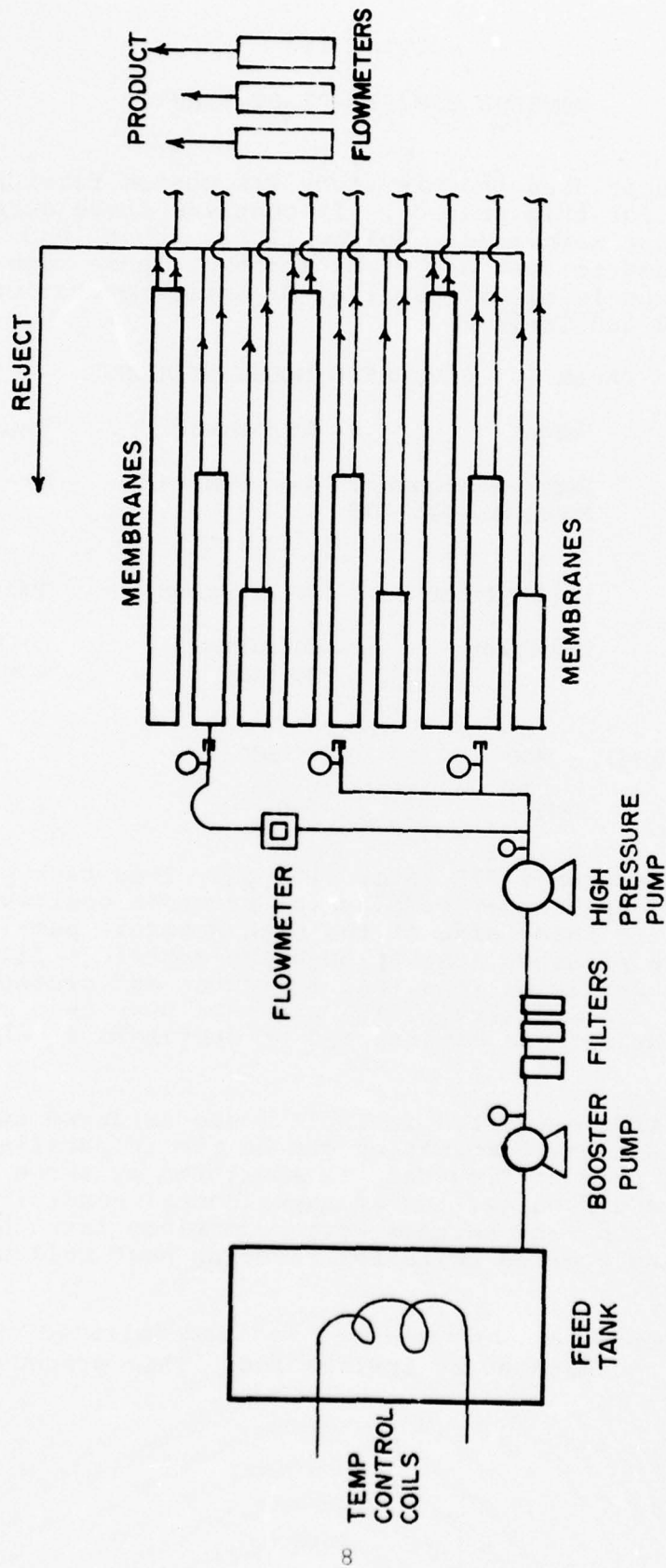

Figure 2. Schematic Diagram of Reverse Osmosis pilot plant

for flushing the modules with the following solution (volume 85 liters):

1.70 kg (3.75 lb)	citric acid
88 ml	Triton X [®] (a detergent)
1.25 gm	Carboxymethyl cellulose

This solution was circulated through the modules for a minimum period of 2 hours, followed by rinsing with deionized water.

Prolonged storage after flushing requires that a formaldehyde (0.3 to 0.5 percent) solution be placed in the modules.

SECTION III

EXPERIMENTAL DESIGN AND RESULTS

The application of RO or any other membrane separation process to the treatment of industrial wastes depends on several factors, including the degree of separation of the waste stream that the membrane can achieve, the rejection of the chemical species in the waste, and the degree to which the membrane resists damage due to attack by the waste. Chrome plating wastes are particularly suspect in the latter case, as hexavalent chromium in an acidic medium is an extremely potent oxidizing agent, as is evidenced by its use as the oxidizing agent in the Chemical Oxygen Demand Test. Another area of concern in applying RO to chrome plating wastes involves the ability of the membrane to achieve sufficient solvent and solute rejection.

Experiments were designed to simulate plating solutions diluted to concentrations anticipated in rinse tanks or in scrubber blowdown water. These solutions were made from technical grade chromium trioxide (CrO_3) and reagent grade sulfuric acid (H_2SO_4) in the proportions found in a plating bath. These solutions were then neutralized with reagent grade sodium hydroxide (NaOH) to a pH of 6.5 ± 0.4 . This neutralization was done to protect the membranes from oxidation by the chromium as previously discussed. Chromium concentrations and water level were checked daily and readjusted when necessary.

All chromium measurements were performed using atomic absorption (AA) spectroscopy with a nitrous oxide-acetylene flame on a Perkin Elmer model 403 atomic absorption unit.

All membranes had previously been used with nickel and cadmium cyanide solutions. Data from these tests indicated that no decrease in membrane performance had occurred. All membranes were cleaned using the recommended procedure before being used with the chromium solutions.

In order to assess the relative performance of the three types of membranes, tests were performed using an influent chromium concentration of approximately 100 mg/l. Data from these tests are given in Table 2.

TABLE 2. RELATIVE MEMBRANE PERFORMANCE

Membrane	R°	\hat{R}
Tubular	0.77	0.116
Spiral Wound	~ 0	0.25
Permasep [®]	0.97	0.69

The Spiral Wound membrane failed to achieve any separation of the chromium. In order to determine whether the membrane had been damaged, a nickel solution was passed through the membrane and the performance was compared with previous nickel tests. No difference in performance was detected.

The Tubular membrane's performance was better, but significantly less than that of the Permasep[®], especially with respect to the product recovery ratio, \hat{R} . On the basis of these results, the Permasep[®] membrane was selected for further testing.

Information from the literature indicates that the performance characteristics of the membrane are a function of feed pressure and/or feed concentration, or variables which are functions of feed pressure and/or feed concentration. To evaluate the effects of varying feed pressure (ΔP), tests were conducted on a solution containing 210 mg/l \pm 7 mg/l chromium at pH 6.0 to 6.5. Each pressure increment was maintained for a minimum of 4 hours to achieve a steady state condition.

Theoretically, variables which are functions of feed pressure are actually functions of the difference between feed pressure and the osmotic pressure of the solution. As previously discussed, permeate (solvent or product flow) flux is proportional to feed pressure minus osmotic pressure:

$$Q_p = W_p (\Delta P - \pi^{\circ}) \quad (4)$$

These data are presented in Figure 3. Note that the plot of product flow versus feed pressure (Q_f versus ΔP) has a positive intercept; inferring that the osmotic pressure in Equation 1A (Appendix) is negative, an impossibility. However, the function relating feed flow, Q_f , with feed pressure can be used for design purpose:

$$Q_f = 0.17178 \Delta P + 1.0491 \quad (5)$$

Product flow, Q_p is related to feed flow by the solvent recovery ratio (see appendix equation A9). The data from Figure 3 was used to prepare a plot of \hat{R} versus ΔP (see Figure 4). These data were combined with a plot of \hat{R} versus C_f (see Figure 5) to yield an equation relating \hat{R} to ΔP and C_f :

$$\hat{R} = Q_p/Q_f = 0.61172 - 0.000028 C_f + 0.00312 \Delta P \quad (6)$$

The relationship given in the literature between solute rejection and feed pressure also involves the term $\Delta P - \pi$ (see Appendix equations A4 and A5). When $1/R^0$ was plotted as a function of $1/\Delta P$, a straight line defined by following equation resulted (see Figure 6):

$$1/R^0 = 0.11852 1/\Delta P + 1.00362 \quad (7)$$

This can be rearranged to form an equation of the same form as equation A4:

$$R^0 = [1.00366 + 0.11822/\Delta P]^{-1} \quad (8)$$

Another series of tests was run to determine the effect of the solute (feed) concentration (C_f) on membrane performance. After cleaning the membrane, an initial chromium concentration of 25 mg/l was used as a feed to the membrane under a pressure of 25.67 bars (370 psi). The concentration of the feed solution was changed at 48 hour increments by adding a CrO_3 , H_2SO_4 mixture which had been neutralized with NaOH as before.

These data are plotted as \hat{R} versus C_f in Figure 5, as previously described. When the equation of this line is combined with the equation of the line in Figure 4, equation 6 results. In addition, an attempt was made to determine K_D in appendix equation A2 by plotting F_S^0 as a function of ΔC for both sets of data, but the graphs were inconsistent with each other and the expressions were not used.

An expression to determine solute separation was still required. Data from both sets of experiments were plotted to determine C_p as a function of $C_m (1-R^0)$ (see Figure 7). R^0 (appendix equation A3) and C_m (appendix equation A8) were calculated for each data point.^m The use of R^0 in place of R^{AVE} in appendix equation A6 yielded satisfactory results. The line determined in Figure 7 was defined by the following equation:

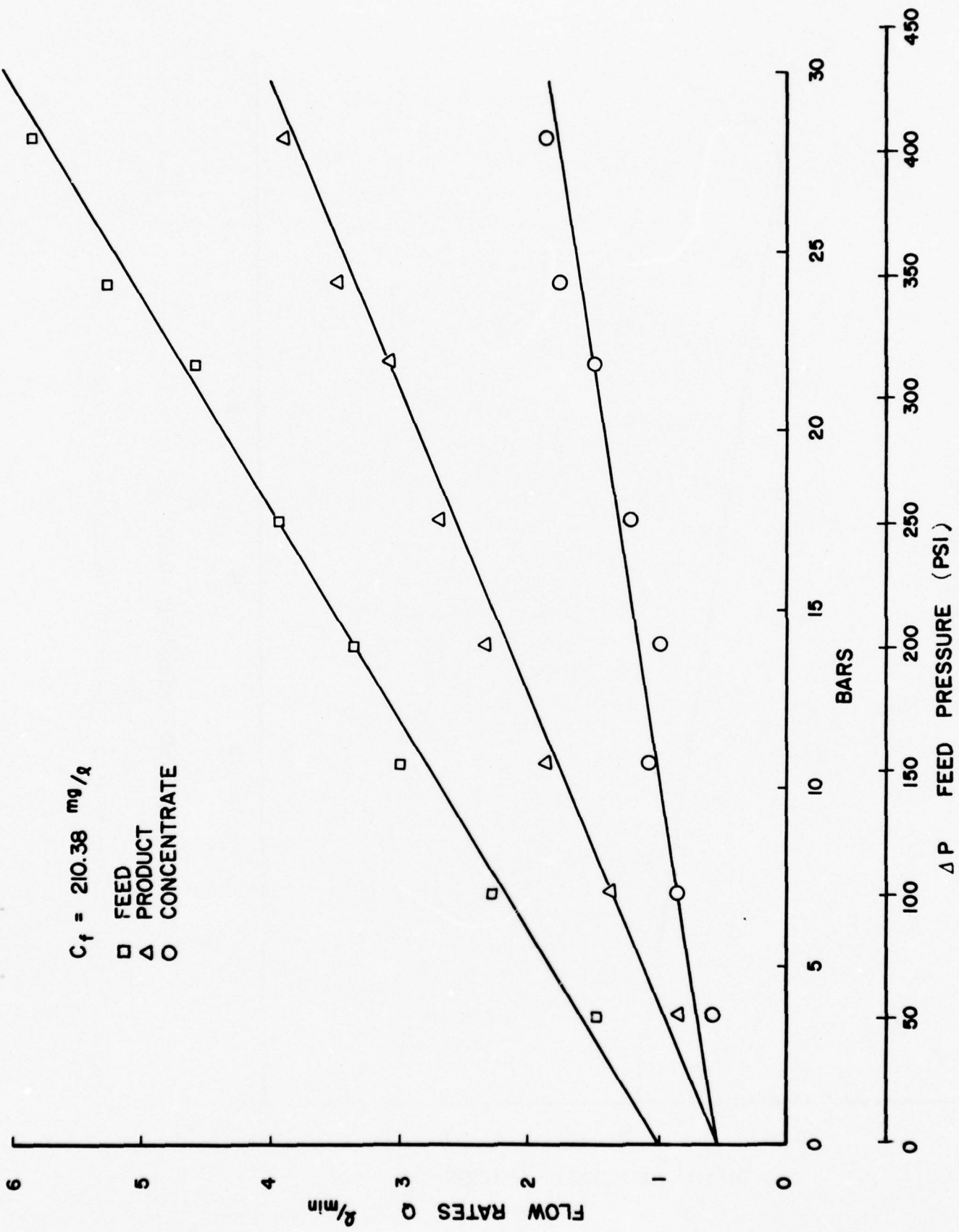

Figure 3. Plot of Flow Rates versus Feed Pressure (ΔP)

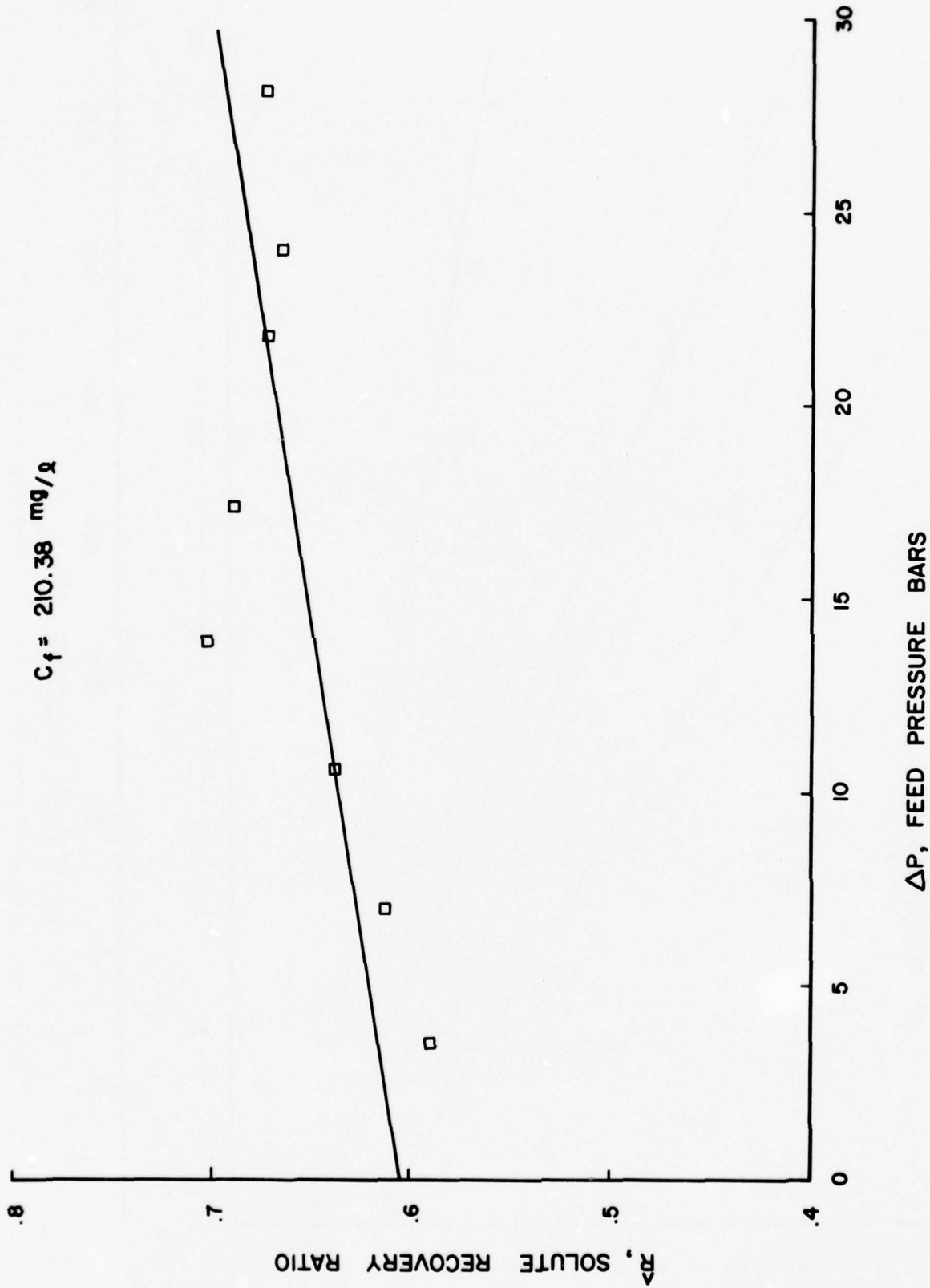

Figure 4. Plot of Solute Recovery Ratio (R) versus Feed Pressure (ΔP)

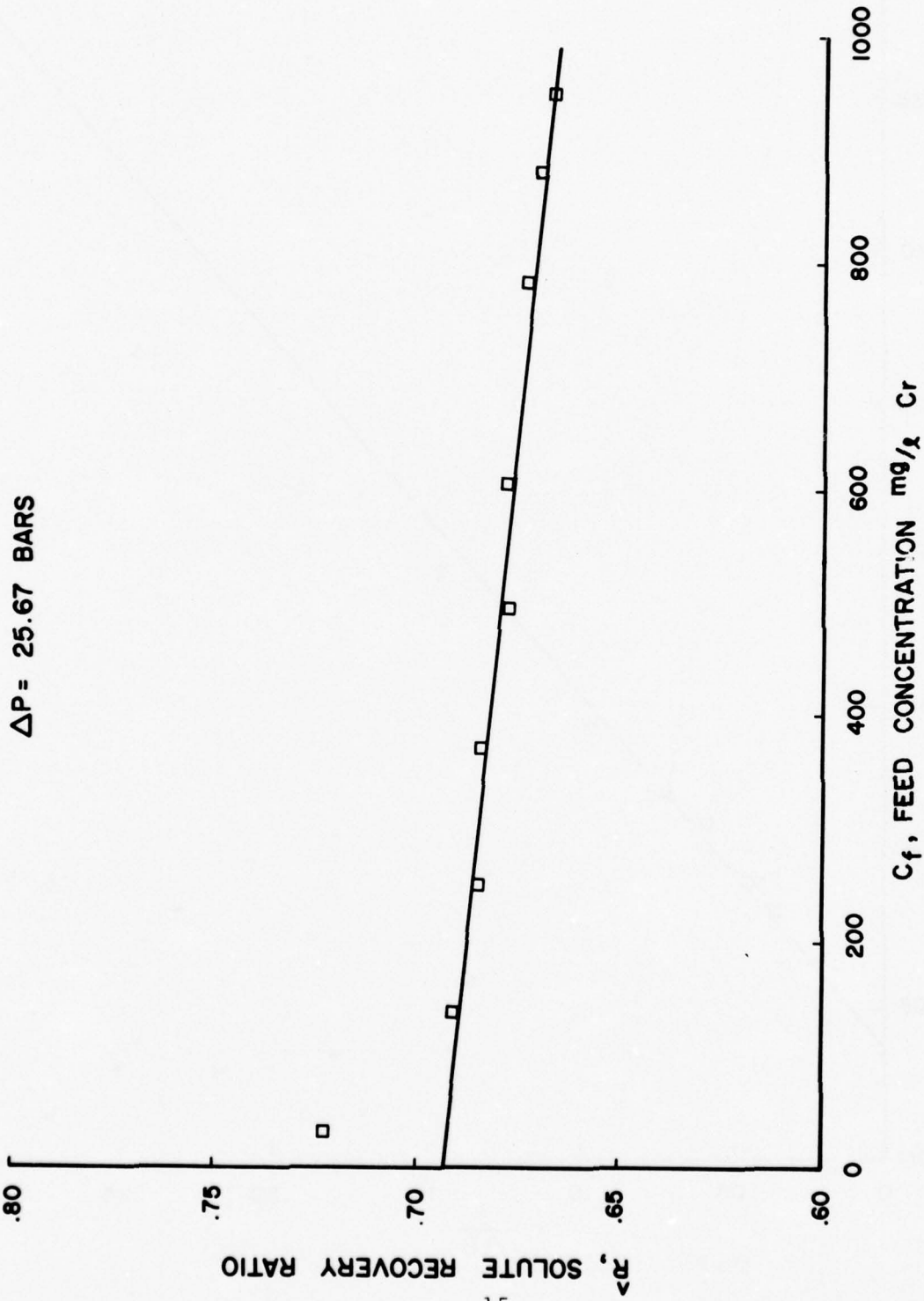

Figure 5. Plot of Solute Recovery Ratio (\hat{R}) versus Feed Concentration (C_f)

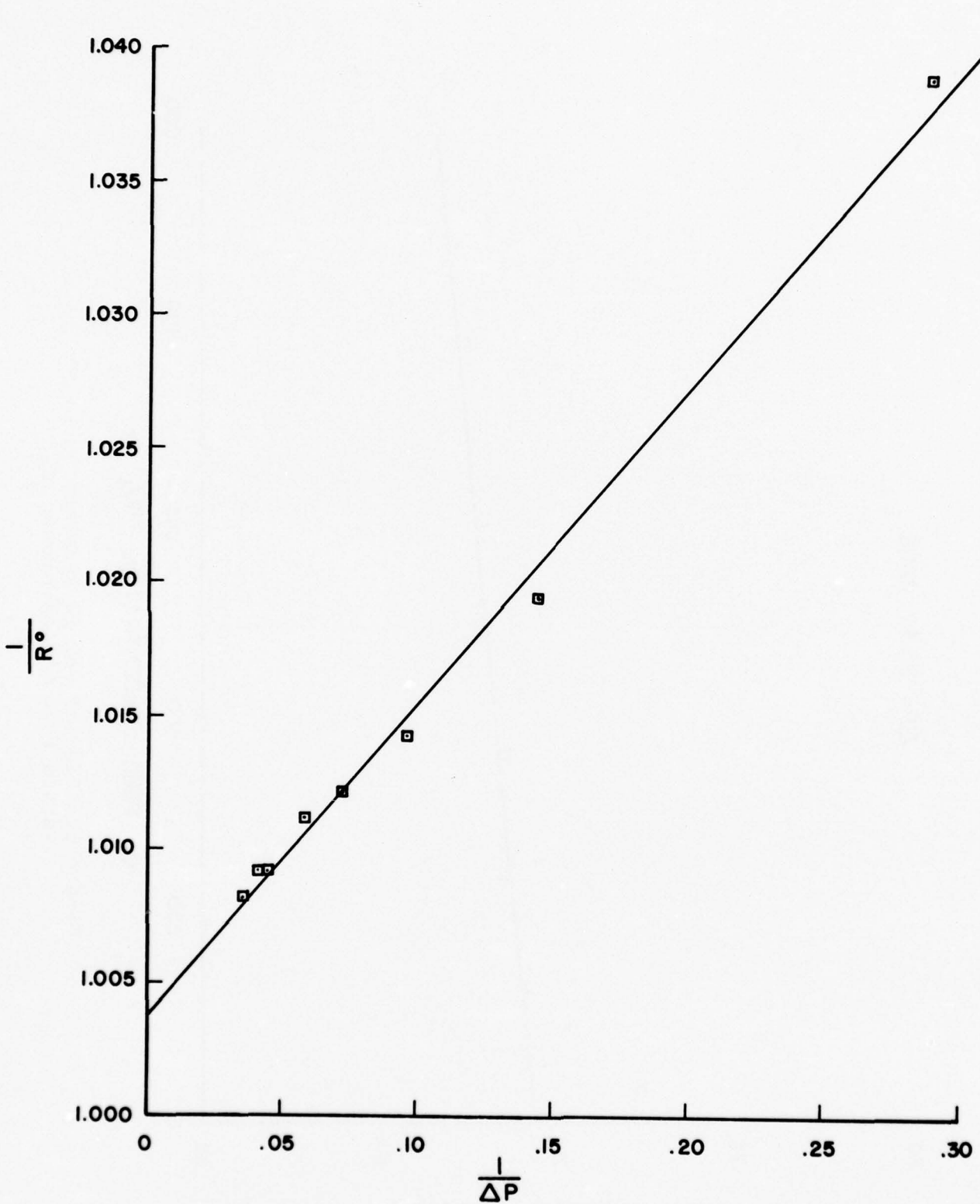

Figure 6. Plot of $1/R^0$ versus $1/\Delta P$
16

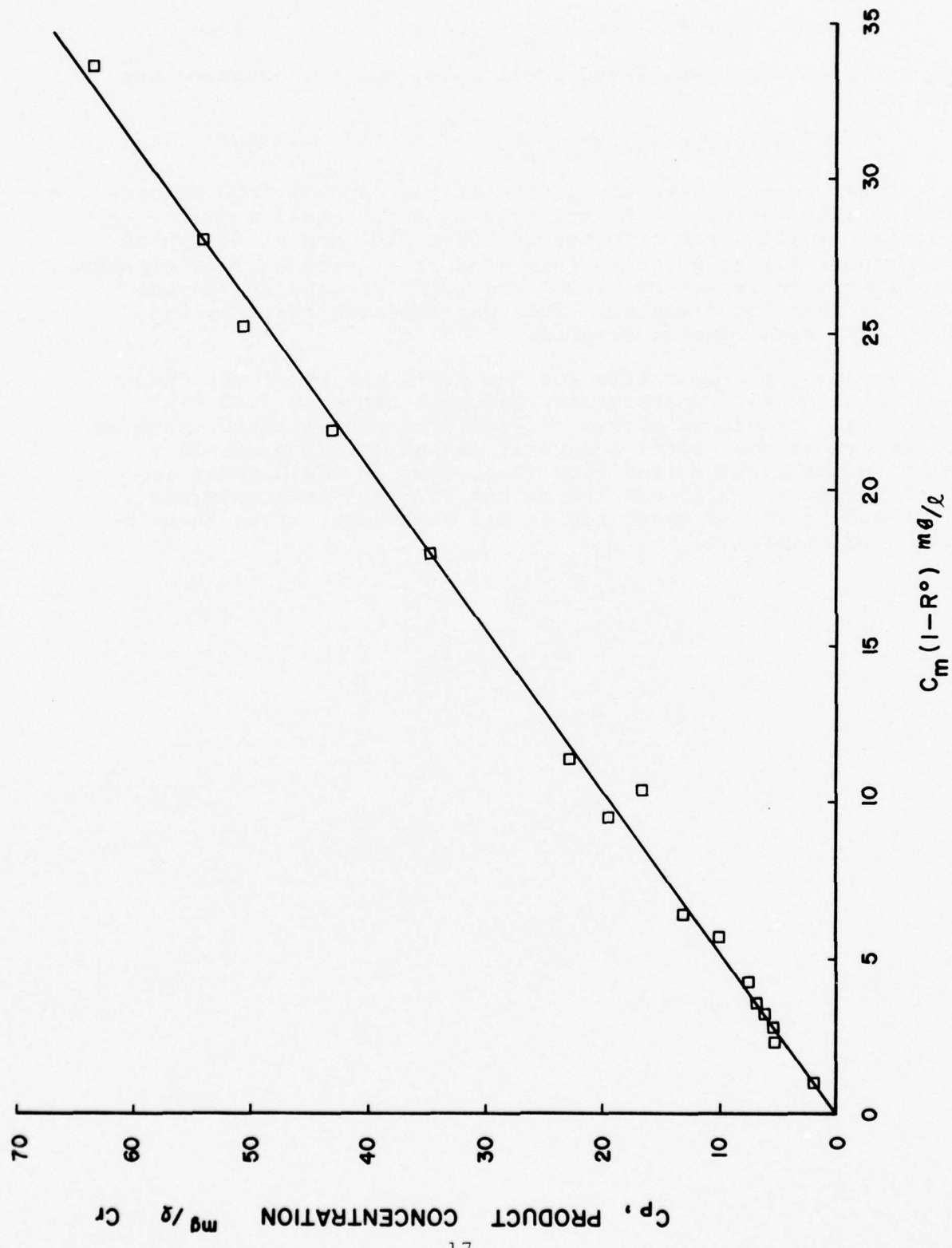

Figure 7. Plot of C_p versus $C_m(1-R^0)$

$$C_p = 1.92587 (1-R^0) C_m + .0015 \quad (9)$$

The intercept was considered negligible, and the equation was used as:

$$C_p = 1.92587 (1-R^0) C_m \quad (10)$$

After several days of testing at the highest feed concentration (950 mg/l), the RO unit was operated until evidence of excessive fouling was evidenced. After 1200 hours, it was no longer possible to maintain this feed rate, even at feed pressures of slightly in excess of 27.75 bars (400 psi) and the device was shut down for cleaning. This was repeated for a second 1600 hours with similar results.

During the preparation for one test, the pH of the chromium feed solution was inadvertently adjusted above pH 7.0. The filters and membranes became clogged with precipitated chromium to the extent that after 2 days it was no longer possible to maintain the maximum feed flow rate, even at the highest operating pressure. Although the reason for this phenomena was not known, care was exercised in all subsequent tests to maintain a pH below 7.0.

SECTION IV

PROPOSED DESIGN

Reverse osmosis can be applied to the chrome plating process described in the introduction by making a number of modifications to the plating line.

An RO unit, with units arranged in some given combination of series and parallel modules, is capable of producing a low flow concentrate stream with a relatively high chromium concentration, and a higher flow product stream containing a dilute concentration of chromium. The chrome plating process offers potential uses for both streams.

The concentrate streams can be added directly back into the plating bath in place of the deionized water currently being added to the bath to replace evaporative losses. This will prove feasible, provided that the concentrate flow rate is less than or equal to the evaporation rate from the plating baths, and there is no excessive buildup of foreign chemicals such as sodium.

The product stream can be used in processes which require relatively clean, but not pure water. Such processes are the scrubber water makeup and the first rinse tank following the plating bath.

The design for such a system is given in Figure 8. The purpose of this design exercise is to demonstrate that RO can be incorporated into a viable closed loop system for the recycle of chromium from a typical Air Force chrome plating operation. The controlling variables are the evaporation rates from the scrubbers, and from the scrubber blowdown rate necessary to maintain adequate scrubber performance, and the chromium concentration in the final rinse tank.

The proposed design utilizes a scrubber design determined as a result of studies performed at the Oklahoma Air Logistic Center (References 5 and 6). A total flow through each scrubber of 20 l/min as currently employed is maintained with a recirculation of 18 l/min and blowdown rate of 2 l/min. The makeup must equal the blowdown rate plus any evaporation in the scrubber. This evaporation rate is expected to be highly variable depending on the flow rate of air through the scrubber, the relative humidity, and temperature. In this design, makeup water is provided through the product side of the RO unit. To design for adequate capacity in the RO unit, conditions under which a reasonable maximum evaporation rate would be

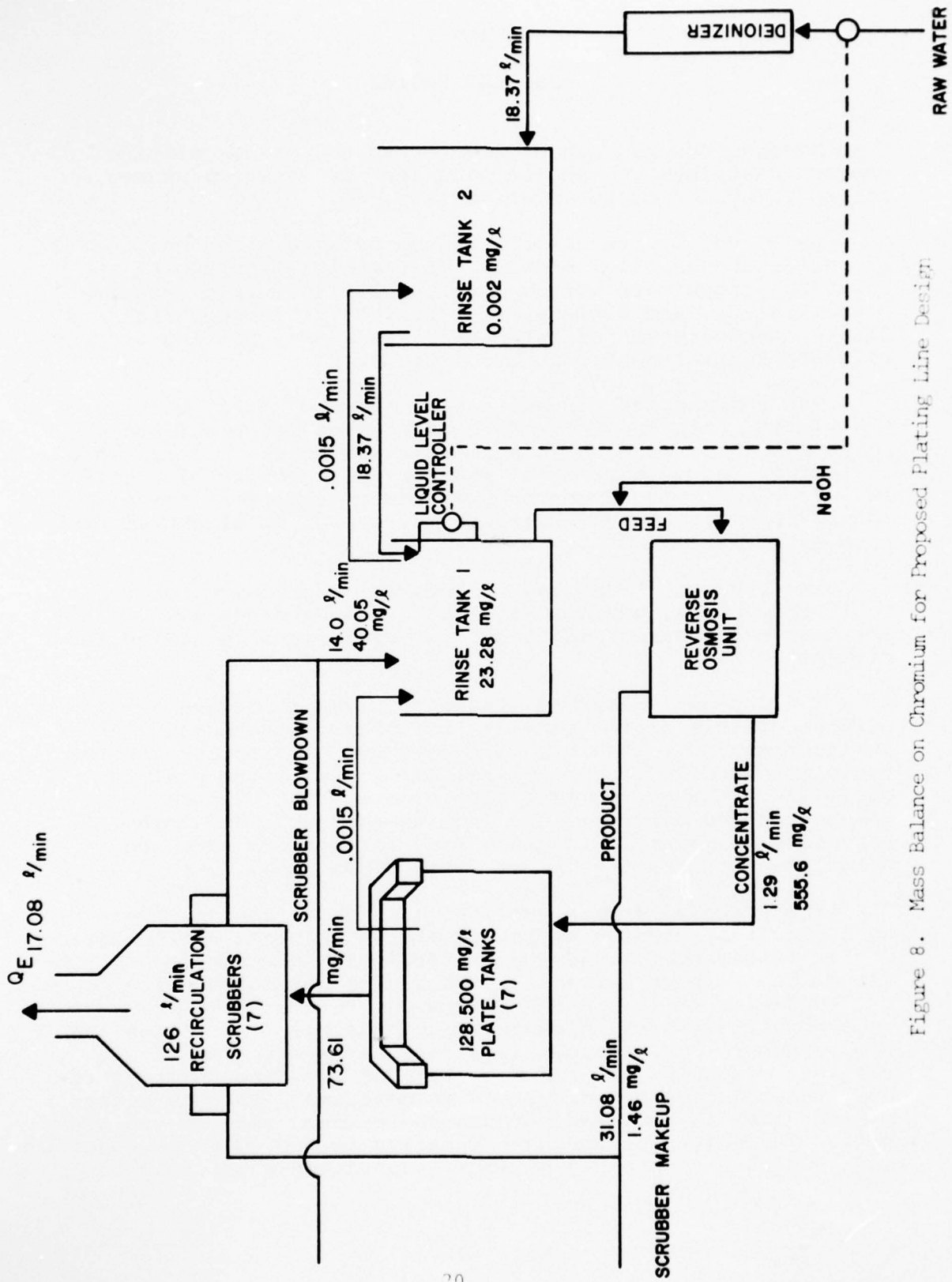

Figure 8. Mass Balance on Chromium for Proposed Plating Line Design

expected were selected for design purposes: 32.2°C (90°F) and 40 percent relative humidity. Assuming that the exhaust air leaves the scrubber at 32.2°C, 100 percent relative humidity, and a flow rate of 100m³/min (currently used), the evaporation rate per scrubber is 2.44 l/min, or 17.08 l/min for all seven scrubbers. Thus, the product flow rate from the RO unit must be (2.0 + 2.44) x 7 = 31.08 l/min. This calculation ignores the 30 ml/min evaporation rate expected from each rinse tank.

Scrubber chromium concentrations were calculated by assuming that each plating bath was half filled with parts being plated and that the current density was 0.8 kiloamps per tank. This yielded a chromium emission rate from each scrubber of 73.61 mg/min.

The chromium concentration in the first rinse tank was calculated from a mass balance on chromium, assuming a 10 ml dragout per part rinsed and nine parts rinsed per hour. The chromium concentration of 128,500 mg/l was assumed constant, since the chromium and sulfuric acid concentrations in each tank are checked and adjusted weekly. The RO unit was designed using the iterative procedure described in the appendix to process slightly more than 31 l/min feed flow and to produce less than 2 l/min of concentrate (see Figure 9).

Sodium hydroxide or some other hydroxide will be required to neutralize the acidity resulting from dragout from the plating bath. Acidity will result from dilution of the H⁺ of the plating bath and the formation and subsequent dissociation of bichromate. As the chromium concentration is decreased, dichromate reacts to form two bichromate ions (Reference 8):

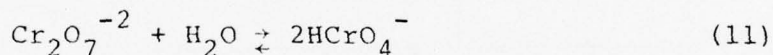

As the pH is increased to pH 6.5 (the pK₁ of chromic acid), the bichromate dissociates with the release of H⁺ (Reference 8):



The dragout rate of 0.0015 l/min of the plating bath containing 0.32 m/l H⁺ and 1.24 m/l Cr₂O₇ (2.5 m/l as HCrO₄⁻) will consume NaOH at a rate of 19.2 mg/min for the H⁺ and 150 mg/min for the HCrO₄⁻. This is a yearly requirement of 89 kg (196 lb) of NaOH. This requirement may be drastically reduced if the pH is maintained below 6.5, as the HCrO₄⁻ would not have to be neutralized. This was not done in the laboratory study because of the concern that the membranes would be attacked. However, this may not be a problem where the chromate species is present instead of the dichromate. In

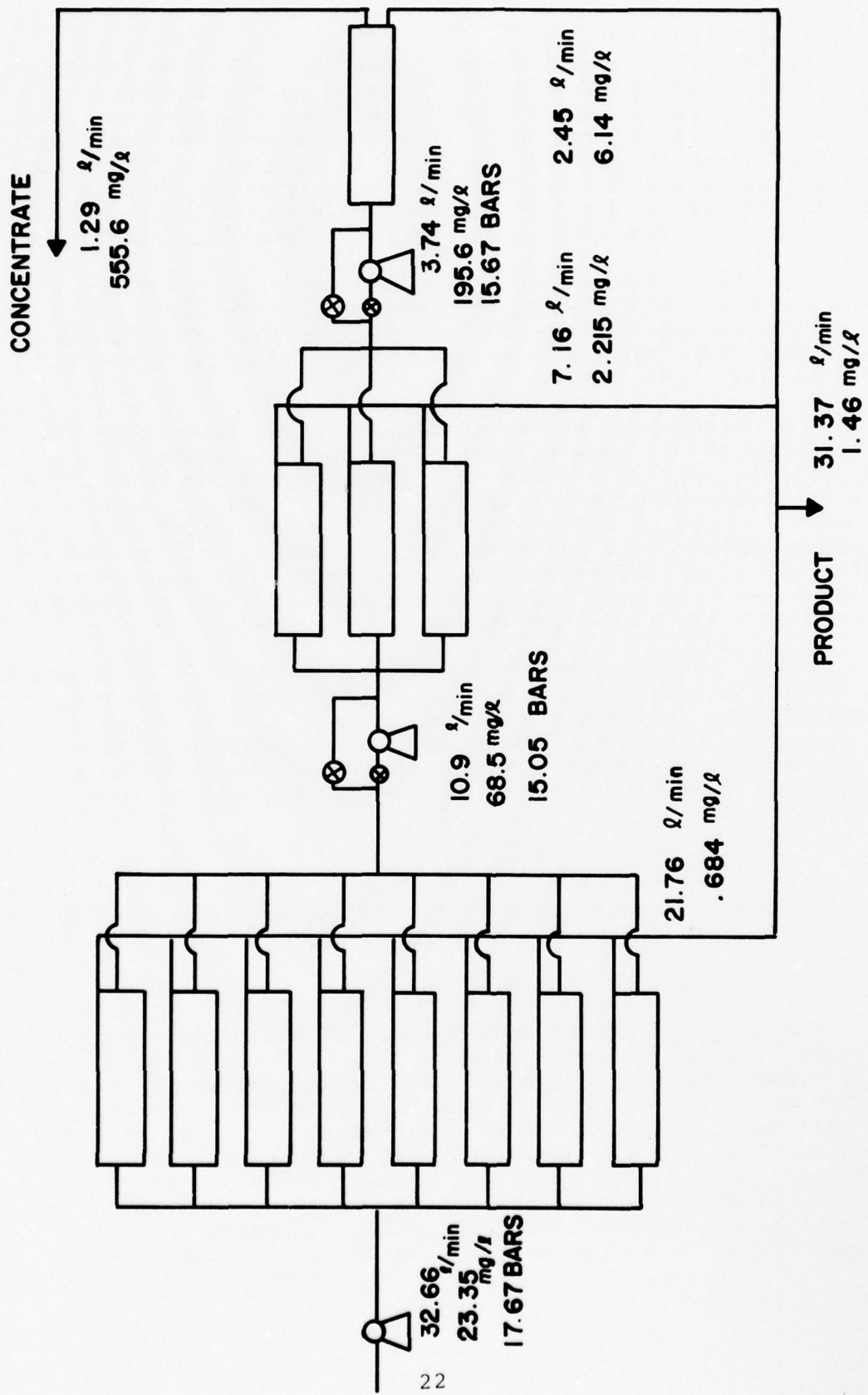

Figure 9. Reverse Osmosis Pilot Plant Designed for Starting Conditions

any case, this question should be addressed in a pilot scale study.

Sodium hydroxide additions may be made either in the rinse tank itself or in the line from the rinse tank to the RO unit. Exact additions must be regulated by some control device using a pH electrode. Care must be exercised in the design of this control system so as not to raise the pH above 7.0.

Flow of deionized water into the system is controlled by a liquid level controller (LLC) on the first rinse bath. This water first passes through the second rinse tank before entering the first rinse tank, thus providing a pure rinse water for the final rinse. This design feature permits compensation for evaporative losses in the scrubbers, provided that the RO unit produces enough product flow to account for the evaporation in the scrubbers and to allow for a scrubber blowdown rate of 2 l/min.

This flow was calculated to balance the evaporative losses in the scrubbers and the plating baths. The chromium concentration was determined from a mass balance on chromium assuming a 10 ml carryover per part (0.0015 l/min) from the first rinse tank.

The final concentrations were determined by reiterating the mass balances until the change in concentration from one iteration to the next was arbitrarily small.

All of the sodium added to the feed to the RO unit will eventually end up in the plating bath. The above calculation for sodium hydroxide addition indicates a sodium addition to the plating bath of 53.71 mg/min (as Na^+). The yearly buildup of sodium in a 7000 liter tank will be 4.03 gm/l. If this accumulation proves to be too much, a cation exchange column operating on the H^+ cycle could be placed in the concentrate line following the RO unit to exchange H^+ for Na^+ .

This design will require the use of certain additional pieces of equipment which are not shown. Some filter arrangement similar to that employed in this study in line before the RO modules will be necessary for protection from premature fouling from suspended material. Flow meters on the product line and scrubber blowdown line will be required to monitor the scrubber evaporation rates. In addition, some provision must be made to cool the RO feed in case the rinse water temperature exceeds 35°C (95°F), as recommended by the manufacturer.

Difficulties in balancing the actual system will be encountered due to variations in the rate of evaporation from both the rinse tanks and the scrubbers. A decrease in evaporation from the scrubbers would result in a lower chromium concentration in the blowdown and a higher blowdown rate into the first rinse tank.

An increase in the scrubber evaporation rate will result in an increase in the chromium concentration of the scrubber water and a decrease in the blowdown rate into the rinse tank. This will cause a minimal increase in the amount of chromium carried over into the second rinse tank and carried out with the parts being rinsed. If the decrease in the scrubber blowdown is significant, as indicated by monitoring the blowdown rate, the flow through the RO unit can be increased, by increasing the feed pressure or by adding additional modules.

This system was designed assuming that the neutralizer tank was not used. If this tank is used, the carryover into the second rinse tank will consist of 0.0015 l/min of 34,500 mg/l NaOH, resulting in a faster buildup of sodium in the plating bath, and larger chemical requirements. This sodium buildup can be compensated for by placing a cation exchange column operating on the H^+ cycle between the RO unit and the plating bath, as previously described.

It should be realized that this design is based on a number of highly variable parameters; however, it should be evident that the implementation of such a system will result in relative ease of maintenance with zero discharge of chromium, a well-rinsed product, and efficient scrubber operation.

SECTION V

CONCLUSIONS

This study was designed to determine if RO could be utilized as a pollution control process for a chrome plating shop. Data from this study indicate that the answer is affirmative. The Permasep® membrane manufactured by duPont combines a high salt rejection rate with a high product recovery rate. A closed system resulting in zero discharge of chromium from water emissions has been designed.

It is recommended that a system similar to this one be installed on an existing chrome plating line at one of the Air Logistics Centers. During this study, the following questions must be considered:

1. What are the long-term variations of performance of the RO membranes?
2. Can the RO unit be operated at a pH below 6.5 to reduce NaOH consumption and Na⁺ buildup in the plating bath?
3. What effects will this system have on the plating process itself?
4. What operational procedures are necessary to implement this system?
5. What personnel procedures and organization changes must be instituted?
6. Is it feasible to reuse the cleaning solutions?
7. What will be the total cost of implementing this system?

REFERENCES

1. Castellan, G. W., Physical Chemistry, Addison-Wesley Publishing Co., Reading MA, 1971.
2. Mertin, U., (ed), Desalination By Reverse Osmosis, The Riverside Press, 1966.
3. Sourirajan, S., Reverse Osmosis, Logos Press Ltd., London, 1970.
4. Weber, W. J. Jr., Physico Chemical Processes for Water Quality Control, Wiley Interscience, New York, 1972.
5. Daley, P. S., A Review of USAF Aerosol Research; Aerosol Generation in Electroplating presented at the 68th Annual Meeting of the Air Pollution Control Association, Boston MA, June, 1975.
6. Shelton, S. P., et al, Water Reuse at Air Force Electroplating Facilities, to be published.
7. van Thoor, T. J. W., Chemical Technology: An Encyclopedic Treatment, New York NY, Barnes and Noble, Inc.
8. Sillen, L. G. and Martell, A. E., Stability Constants of Metal-Ion Complex, Special Publication No 17, The Chemical Society, London 1964 and Supplement 1, 1972.
9. "Reverse Osmosis and Electroplating," Industrial Finishing, 50, 7, 34, 1974.
10. Donnelly, R. G., et al, "Reverse Osmosis Treatment of Electroplating Wastes," Plating, 61, 432, 1974.
11. Golomb, A., "Reverse Osmosis for Plating Waste Treatment," Electroplating Metal Finish, 26, 10, 12, 1973, Chemical Abs 80, 87255, 1974.
12. Rozelle, L. T., et al, New Membranes for Reverse Osmosis Treatment of Metal Finishing Effluents, NTIS PB 240, 722, Dec 1973.
13. Golomb, A., "Application of Reverse Osmosis to Electroplating Waste Treatment, Part IV, Potential Reutilization of Chromium Plating Wastes by Other Industries," Plating 61, 931, 1974.

APPENDIX

TABLE OF METRIC CONVERSIONS

psi	x	.06939	=	bars	(pressure)
gallons	x	3.785	=	liters	(volume)
pounds	x	453.6	=	grams	(mass)
(°F - 32)/1.8			=	°C	(temperature)
lb/2.2			=	kg	(mass)

LIST OF ABBREVIATIONS

C	solute concentration	M/l
C _c	solute concentration in concentrate	mg/l
C _f	solute concentration in feed solution	mg/l
C _m	mean solute concentration or concentrate solution side of membrane inside module	mg/l
C _p	solute concentration in product solution	mg/l
Cr	chromium	
C _{wp}	concentration of water in product	m/l
E	chromium emission from scrubber	g Cr/day
I	current intensity	kiloamps
K ₄	empirical constant	
M	moles	
Q _c	volumetric flow rate of concentrate	l/min
Q _f	volumetric flow rate of feed	l/min
Q _p	volumetric flow rate of product	l/min
R	universal gas constant (0.082054)	$\frac{1\text{-atmospheres}}{^{\circ}\text{K M}}$

\hat{R}	product recovery ratio	
R°	solute rejection ratio	
RO	reverse osmosis	
T	absolute temperature	°Kelvin
eq	equivalents	
hp	horsepower	
kA	kiloamps	
kg	kilograms	
l	liter	
m	meter	
mg	milligram	
ml	milliliter	
π°	osmotic pressure	atmospheres
psi	pound (force) per square inch	

DESIGN EQUATIONS

The product, or permeate, is that portion of the feed solution which passes through the membrane to the dilute side. This volumetric flow rate of the solvent per module is a function of the pressure gradient across the membrane and individual characteristics of the membrane:

$$Q_f = W_p (\Delta P - \pi^{\circ}) \quad (A1)$$

where:

Q_f = product flow rate (l/min)

W_p = coefficient of water permeation (l/min-bar)

ΔP = feed pressure (bars)

π° = osmotic pressure (bars)

W_p may be determined experimentally.

Solute flux through the membrane is a function of the solute concentration gradient:

$$F_S^O = K_p \Delta C \quad (A2)$$

where:

F_S^O = solute flux (M/min)

K_p = coefficient of permeability (l/min)

ΔC = change in concentration of solute species across the membrane (M/l)

The coefficient of permeability is also a characteristic of a particular membrane and its method of manufacture. The change in concentration of solute species across the membrane is related to the rejection rate for that species:

$$R^O = \frac{C_c - C_p}{C_c} \quad (A3)$$

where:

R^O = fractional solute rejection

C_c = concentration of solute in concentrate side (M/l)

C_p = concentration of solute on product side (M/l)

Solute rejection can be related to feed pressure by the following formula:

$$R^O = \left[1 + \frac{K_p C_{wp}}{W_p (\Delta P - \pi^O)} \right] - 1 \quad (A4)$$

where:

C_{wp} = concentration of water in the product (M/l) or if the constants K_p , C_{wp} and W_p are combined into one empirical constant K_4 :

$$\frac{1}{R^O} = \left[1 + \frac{K_4}{(\Delta P - \pi^O)} \right] \quad (A5)$$

The product concentration is a function of the mean solute concentration (on the concentrate side of the membrane) and the average reject ratio:

$$C_p = (1 - R_{AVE}^O) C_m \quad (A6)$$

where:

$$R_{AVE}^O = \left[1 + \frac{K_p C_{wp} \Delta C}{W_p (\Delta P - \pi^O) C_f} \right]^{-1} \quad (A7)$$

where:

R_{AVE}^O = average fractional solute rejection

C_f = feed concentration (M/l)

$$C_m = \frac{Q_c C_c + Q_f C_f}{Q_c + Q_f} \quad (M/l) \quad (A8)$$

C_m = mean solute concentration (M/l)

Q_c = concentrate flow (l/min)

C_c = concentration of solute in concentrate (M/l)

Q_f = feed flow rate (l/min)

The product recovery ratio is defined as:

$$\hat{R} = Q_p / Q_f$$

where:

\hat{R} = fractional product recovery ratio

Q_p = flow rate of product (l/min)

This ratio is usually constant for a given membrane.

DESIGN PROCEDURE

Equations A6, A4, A2, and A1, together with equation 11 and equations describing volumetric and mass flow balances for the module are sufficient for the design for a module under initial (clean and undamaged) conditions

(as described in this report, continued operation will alter the membrane characteristics). The design equations are:

$$a. \quad Q_f = Q_p + Q_c \quad (\text{volumetric flow balance})$$

$$b. \quad Q_f C_f = Q_p C_p + Q_c C_c \quad (\text{mass balance})$$

$$c. \quad C_m = \frac{Q_c C_c + Q_f C_f}{Q_c + Q_f}$$

$$d. \quad Q_f = 0.17178 \Delta P + 1.04691$$

$$e. \quad \hat{R} = 0.61172 - 0.000028 C_f + 0.00312 \Delta P$$

$$f. \quad \left[R^0 = 1.00366 + \frac{0.1182}{\Delta P} \right]^{-1}$$

$$g. \quad C_p = 1.92587 (1 - R^0) C_m$$

The design procedure is as follows:

1. An initial maximum flow for each module must be determined. This is due to the fact that the feed pressure must be increased as the module becomes fouled with chromium in order to maintain a given flow rate. The maximum pressure recommended for this module is 27.76 bars (400 psi). The maximum flow was determined (rather arbitrarily) as the flow at 20.8 bars (300 psi) or approximately 4.5 l/min. The number of modules is, therefore, equal to the feed flow divided by 4.5, raised to the next higher integer. For example, for a Q_f of 32.66 l/min and C_f of 23.35 mg/l, 7.26 or 8 modules will be required. This will result in a Q_f per module of 4.0825 l/min.

2. The pressure necessary to operate a module at this pressure is calculated from D:

$$\Delta P = 17.67 \text{ bars (254.65 psi)}$$

3. R^0 is calculated for this ΔP from G:

$$R^0 = 0.989$$

4. \hat{R} is calculated for this C_f and ΔP from E:

$$\hat{R} = 0.6662$$

5. Q_p is determined from this \hat{R}

$$Q_p = \hat{R} Q_f$$

$$Q_p = 0.6662 (4.0825) = 2.72 \text{ l/min}$$

6. Calculate Q_c from A:

7. C_p is determined using an iterative procedure:

Assume $C_p = 0$; this implies (from B) that

$$Q_f C_f = Q_c C_c \text{ or } Q_f C_f + Q_c C_c + 2(Q_f C_f)$$

8. Calculate C_m from C:

$$C_m = 35.129 \text{ mg/l}$$

9. Calculate C_p from G:

$$C_p = 0.74419 \text{ mg/l}$$

10. Calculate C_c from B:

11. Reiterate steps 8 and 9 until the change in C_p is arbitrarily small;

$$C_p = 0.684 \text{ mg/l}$$

See Tables A-1 and A-2 for the data constants for C_f and ΔP , respectively.

TABLE A-1. DATA FOR CONSTANT C_f

$C_f = 210.38 \text{ mg/l}$

Feed Pressure ΔP psi	Feed Pressure ΔP bars	Feed Flow Q_f l/min	Product Flow Q_p l/min	Product Conc C_p mg/l	Con- centrate Flow Q_c l/min	Con- centrate Conc C_c mg/l	\hat{R} Recovery Ratio Q_p/Q_f	R^0 Reject Ratio $\frac{C_c - C_p}{C_c}$	C_m mg/l	$\frac{1}{\Delta P}$ bars ⁻¹	$\frac{1}{R^0}$	$C_m^a (1-R^0)$
50	3.469	1.51	.89	16.4	.62	447	.589	.963	279.25	.2883	1.0384	10.332
100	6.94	2.32	1.42	9.99	.90	514	.612	.981	295.24	.1441	1.0194	5.610
152	10.55	3.03	1.93	7.61	1.1	536	.637	.986	297.11	.0948	1.0142	4.16
200	13.88	3.41	2.39	6.82	1.02	567	.701	.988	292.49	.0720	1.0121	3.51
250	17.35	3.97	2.73	6.27	1.25	589	.688	.989	301.05	.0576	1.0111	3.312
305	21.76	4.62	3.10	5.78	1.51	611	.671	.991	309.06	.0460	1.0091	2.782
346	24.01	5.30	3.52	5.62	1.78	638	.664	.991	317.89	.0416	1.0091	2.861
405	28.10	5.87	3.94	5.41	1.89	660	.671	.992	319.89	.0356	1.0081	2.559

$$a C_m = \frac{Q_c C_c + Q_f C_c}{Q_c + Q_f}$$

TABLE A-2. DATA FOR CONSTANT ΔP

$\Delta P = 25.67$ BARS (370 psi)

C_f mg/l	Q_f l/min	C_p	Q_p	C_c	Q_c	Q_p/Q_f R Recovery Ratio	R^o Reject Ratio $\frac{C_c - C_p}{C_c}$	C_m^a	C_m
25.77	7.562	2.10	5.469	83.27	2.093	.723	.975	38.235	.956
135.2	7.57	12.9	5.223	402	2.405	.690	.968	199.45	6.382
248.74	7.54	19.19	5.165	738.96	2.375	.685	.974	366.165	9.520
369.5	7.45	22.53	5.091	1086.25	2.359	.683	.979	541.87	11.379
494	7.532	34.9	5.100	1415	2.432	.677	.975	718.796	17.97
604	7.545	42.91	5.110	1720	2.435	.677	.975	876.291	21.907
780.5	7.506	50.39	5.045	2252.3	2.461	.672	.978	1143.909	25.166
879.33	7.446	53.83	4.979	2455.5	2.467	.669	.978	1271.584	27.975
949.2	7.192	63.24	4.792	2520.4	2.400	.666	.975	1342.328	33.58

$$a C_m = \frac{Q_c C_c + Q_f C_f}{Q_c + Q_f}$$

INITIAL DISTRIBUTION

Hq USAF/PREE	1	AU/Surgeon	1
Hq USAF/PREVP	1	AFOSR	1
Hq USAF/PREX	1	AFAPL	1
Hq USAF/RDPS	2	AFAL/TSR	1
Hq USAF/SAFOI	1	AFFDL/TST	1
Hq USAF/SGPA	2	AMRL/DAL	1
Hq Comd USAF/DEE	1	AFML/DO (Library)	1
CINCAD/DEEV	2	OEHL/CC	3
CINCAD/DEECV	1	OEHL/OL-AA	1
CINCAD/SGPAP	1	OEHL/OL-AB	1
AFCS/DEEE	1	AFWL/SUL (Tech Library)	1
AFLC/SGB	1	AFGL/XOP	1
AFLC/DEPV	1	USAFSAM/EDE	2
AFLC/MAUT	1	AFRPL/Library	1
AFLC/MMRF	1	FTD/LGM	1
AFSC/DE	1	AMRL/THE	1
AFSC/SD	1	ASD/ENAMC	1
AFSC/DEV	1	ASD/ENESS	1
AFSC/SGB	1	ASD/ENFPA	1
AFSC/SGPE	1	ASD/DEP	1
AFSC/DLCAM	2	ASD/SMKF	1
ATC/DEPV	1	RADC/DOT	1
ATC/SGPAP	1	AEDC/DEE	1
AAC/DEV	1	SAMTEC/SEH	1
AAC/SGB	1	SAMSO/DEC	1
MAC/SGPE	1	SAMSO/SG	1
MAC/DEEE	1	AMD/RDU	1
MAC/DEMP	1	ADTC/CSV	1
CINCPACAF/DEMU	2	ADTC/DLOSL (Tech Library)	1
CINCPACAF/SGPE	1	AFFTC/DE	1
CINCSAC/DEPA	2	AFETR/DER	1
CINCSAC/DEPV	1	ESD/DE	1
CINCSAC/SGPA	1	1035 USAF Tech Ops Gp	1
TAC/DE	1	USAF Rgn Civ Engr	3
TAC/DEEV	1	SAMMA/MAGCB	1
TAC/SGPB	1	USAFSO/DEE	1
USAFSS/DEE	1	1 Med Service Wg/SGB	1
USAFSS/DEMM	1	USAF Hosp/SGPM	1
CINCUSAFE/Surgeon	1	DDC/TCA	12
CINCUSAFE/DEPV	1	ARPA	1
AFISC/SGMS	1	Def Rsch & Engr/AD (E&LS)	1
AFISC/SES	2	OASD/(I&L)ES	1
AFRES/DEEE	1	USA Environ Hygn Agcy	1
USAF/DEV	1	Chief of Engr/ENGMC-RD	1
3800 ABW/DEE	1	Dir, USA WW Exp Stn	1
AFIT/DEM	1	USA CERL	1
AU/LDG	1	Dir, USA Eng R&D Lab/MERDC	1

INITIAL DISTRIBUTION (CONCLUDED)

Dept of the Army/DARD-ARE-E	1
AFRCE/Eastern Region	1
AFRCE/Central Region	1
AFRCE/Western Region	1
Chief of Naval Ops/Environ Protection Div, OP-45	1
NCEL, Code 25111	1
Naval Air Dev Ctr/MAE	1
Naval Ship R&D Ctr (Code 3021)	1
Univ of New Mexico/Tech Appl Ctr	1
Technology Transfer Staff (EPA)	1
Office of R&D (EPA)	1
National Science Foundation	1
US Army Med Bioengr R&D Lab SGRD-UBG	1
AFCEC/SU	1
AFCEC/SUL (Tech Library)	1
AFCEC/WE	1
AFCEC/EV	2
AFCEC/EVW	4