

AD-A040 218

PERCEPTRONICS INC WOODLAND HILLS CALIF
STUDIES AND APPLICATION OF ADAPTIVE DECISION AIDING IN ANTI-SUB--ETC(U)
FEB 77 A LEAL, E SHAKET, P C GARDINER
PTR-1035-77-2

F/G 15/1

N00014-76-C-0864

NL

UNCLASSIFIED

1 OF 1
ADA
040 218

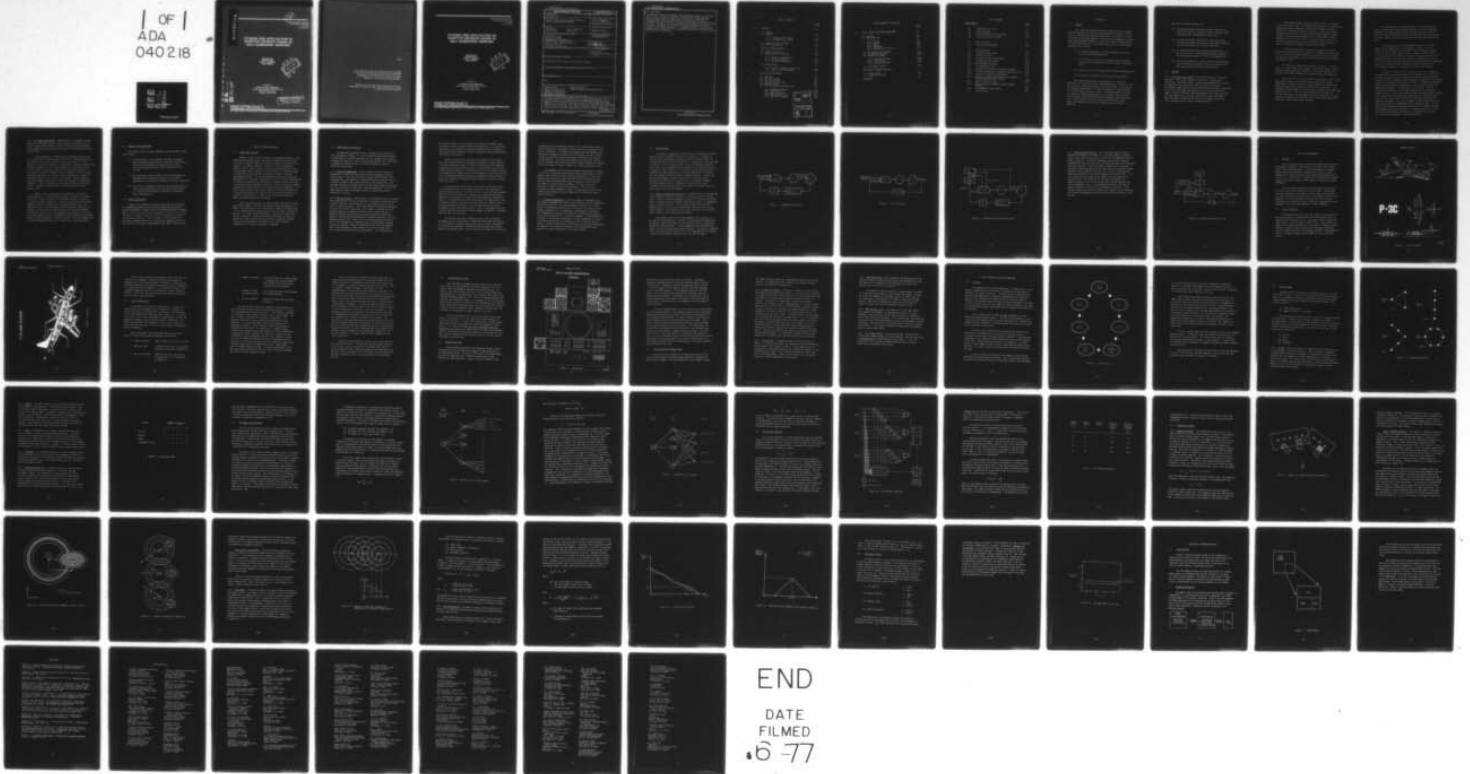

AD A 040218

12

Technical Report PTR-1035-77-2
Contract N00014-76-C-0864
N196-141
February 1977

STUDIES AND APPLICATION OF ADAPTIVE DECISION AIDING IN ANTI-SUBMARINE WARFARE

ANTONIO LEAL
EFRAIM SHAKET
PETER C. GARDINER
AMOS FREEDY

DDC
APR 12 1977
JUN 6 1977
RESERVE
C
A

Prepared For:

OFFICE OF NAVAL RESEARCH
Engineering Psychology Program, Code 455
800 North Quincy Street
Arlington, Virginia 22217

AD No. _____
DDC FILE COPY

DISTRIBUTION STATEMENT A
Approved for public release;
Distribution Unlimited

PERCEPTRONICS

6271 VARIEL AVENUE • WOODLAND HILLS • CALIFORNIA 91367 • PHONE (213) 884-7470

NOTES

The views and conclusions contained in this document are those of the authors and should not be interpreted as necessarily representing the official policies, either expressed or implied, of the Office of Naval Research or the United States Government.

Approved for Public Release; Distribution Unlimited.
Reproduction in whole or part is permitted for any purpose of the United States Government.

Technical Report PTR-1035-77-2
Contract N00014-76-C-0864
N196-141
February 1977

STUDIES AND APPLICATION OF ADAPTIVE DECISION AIDING IN ANTI-SUBMARINE WARFARE

ANTONIO LEAL
EFRAIM SHAKET
PETER C. GARDINER
AMOS FREEDY

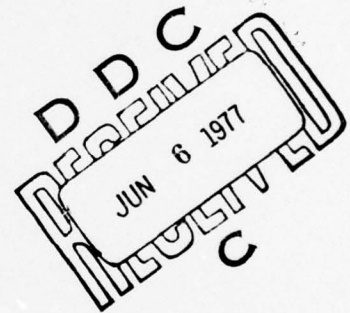

Prepared For:

OFFICE OF NAVAL RESEARCH
Engineering Psychology Program, Code 455
800 North Quincy Street
Arlington, Virginia 22217

PERCEPTRONICS

6271 VARIEL AVENUE • WOODLAND HILLS • CALIFORNIA 91367 • PHONE (213) 884-7470

UNCLASSIFIED

SECURITY CLASSIFICATION OF THIS PAGE (When Data Entered)

14
6

REPORT DOCUMENTATION PAGE		READ INSTRUCTIONS BEFORE COMPLETING FORM
1. REPORT NUMBER PTR-1035-77-2	2. GOVT ACCESSION NO.	3. RECIPIENT'S CATALOG NUMBER
4. TITLE (and Subtitle) Studies and Application of Adaptive Decision Aiding in Anti-Submarine Warfare		5. TYPE OF REPORT & PERIOD COVERED Technical Report
		6. PERFORMING ORG. REPORT NUMBER
7. AUTHOR(s) Antonio Leal, Peter C. Gardiner Efraim Shaket, Amos Freedy		8. CONTRACT OR GRANT NUMBER(s) N00014-76-C-0864
9. PERFORMING ORGANIZATION NAME AND ADDRESS Perceptronics, Inc. 6271 Variel Avenue Woodland Hills, CA 91367		10. PROGRAM ELEMENT, PROJECT, TASK AREA & WORK UNIT NUMBERS Work unit NR196-141
11. CONTROLLING OFFICE NAME AND ADDRESS Office of Naval Research, Code 455 800 N. Quincy Street Arlington, Virginia 22217		12. REPORT DATE February 1977
		13. NUMBER OF PAGES 126 pp.
14. MONITORING AGENCY NAME & ADDRESS (if different from Controlling Office)		15. SECURITY CLASS. (of this report) Unclassified
		15a. DECLASSIFICATION DOWNGRADING SCHEDULE
16. DISTRIBUTION STATEMENT (of this Report) Approved for Public Release, Distribution Unlimited		
17. DISTRIBUTION STATEMENT (of the abstract entered in Block 20, if different from Report)		
18. SUPPLEMENTARY NOTES None		
19. KEY WORDS (Continue on reverse side if necessary and identify by block number) Command Control Submarine Warfare Computer Aid Decisions TACCO (Tactical Coordination Officer) Adaptive Learning Decision Man/Machine Interaction Man/Computer Interaction		
20. ABSTRACT (Continue on reverse side if necessary and identify by block number) This report summarizes the analysis and algorithm designs for the application of adaptive decision aiding methodology to airborne ASW operation. The objective focuses on the transition of the ADDAM (Adaptive Decision Aiding Methodology) to the decision functions of the Tactical Coordination Officers (TACCO) in the P3 aircraft. The report reviews the P3 ASW decision environment, describes the mission objectives, analyzes the TACCO decision tasks, and reviews currently available computational and decision aids. Methodology used (continued)		

DD FORM 1473 1 JAN 73

EDITION OF 1 NOV 65 IS OBSOLETE

UNCLASSIFIED

SECURITY CLASSIFICATION OF THIS PAGE (When Data Entered)

394285

UNCLASSIFIED

SECURITY CLASSIFICATION OF THIS PAGE(When Data Entered)

#20 (continued)

in submarine tracking are reviewed. Detailed decision analysis of the TACCO decision task is described and mapped into decision theoretic concepts in terms of decision trees, probabilities, and utilities. Algorithms for employing adaptive decision aiding within the TACCO decision task are developed for a set of decisions involving sensor pattern selection and number of sensors per pattern for a given probability distribution of submarine locations. An adaptive utility model is developed together with utility and probability assessment procedures. An implementation plan is described for a demonstration system which will be operated in the real P3 aircraft computer under simulation conditions.

UNCLASSIFIED

SECURITY CLASSIFICATION OF THIS PAGE(When Data Entered)

TABLE OF CONTENTS

	<u>PAGE</u>
1. OVERVIEW	1-1
1.1 Summary	1-1
1.2 Approach	1-2
1.2.1 The Airborn ASW Problem	1-2
1.2.2 The ADDAM System Concept	1-5
1.3 Summary of Tasks Performed	1-6
1.4 Report Organization	1-6
2. ADAPTIVE AIDING METHODOLOGY	2-1
2.1 ADDAM System Overview	2-1
2.2 ADDAM Theoretical Structure	2-2
2.2.1 Probability Aggregation	2-2
2.2.2 Utility Estimation	2-2
2.2.3 Strategy Recommendation	2-4
2.3 Aiding Dynamics	2-5
2.3.1 Aiding in Information Acquisition	2-5
2.3.2 Aiding in Action Selection	2-9
3. THE P-3C ASW ENVIRONMENT	3-1
3.1 Overview	3-1
3.2 The P-3C Aircraft	3-1
3.3 The P-3C Mission	3-4
3.4 The TACCO Decision Task	3-7
3.5 Computation Aids	3-7
3.6 The P-3C Simulator Update System	3-9
3.6.1 Probability Contour	3-10
3.6.2 The Track-Fix	3-10
3.6.3 Buoy Pattern Aids	3-11
3.6.4 MAD Detection Circle	3-11
3.6.5 SS1 and SS2 Features	3-11

ACCESSION FOR	
NTIS	White Section <input checked="" type="checkbox"/>
DOC	Buff Section <input type="checkbox"/>
UNANNOUNCED	<input type="checkbox"/>
JUSTIFICATION.....	
BY.....	
DISTRIBUTION/AVAILABILITY CODES	
Dist.	AVAIL. and/or SPECIAL
A	

TABLE OF CONTENTS (Continued)

	<u>PAGE</u>
4. THE P-3 ADAPTIVE DECISION AIDING MODEL	4-1
4.1 Overview	4-1
4.2 Decision Space	4-4
4.2.1 Tri-Tac	4-4
4.2.2 Barrier	4-6
4.2.3 Wedge	4-6
4.2.4 Entrapment	4-6
4.2.5 Pattern Characteristics	4-6
4.3 The Adaptive Utility Model	4-8
4.4 The Training Algorithm	4-13
4.5 Probabilistic Models	4-16
4.5.1 Submarine Detection	4-16
4.5.2 False Alarms	4-23
4.5.3 Resource Depletion	4-24
4.6 Environmental States	4-28
5. PRELIMINARY IMPLEMENTATION PLAN	5-1
5.1 System Concept	5-1
5.2 System Specifications	5-1
6. REFERENCES	6-1

LIST OF FIGURES

<u>FIGURE NUMBER</u>		<u>PAGE</u>
2-1	Information Acquisition	2-6
2-2	Action Selection	2-7
2-3	Information Acquisition With Aiding	2-8
2-4	Action Selection With Aiding	2-10
3-1	The P-3C Aircraft	3-2
3-2	TACCO Station Arrangement	3-8
4-1	TACCO Task Cycle	4-2
4-2	The Major Pattern Groups	4-5
4-3	The Decision Space	4-7
4-4	The Basic Utility Decision Model	4-10
4-5	The Modified Utility Model	4-12
4-6	Decision Model Structure	4-14
4-7	The Training Algorithm	4-15
4-8	Probability Distribution and Pattern Coverage	4-18
4-9	A Priory Distribution of Submarine Location at $t=t_1$	4-20
4-10	A Composite Probability Distribution	4-21
4-11	Contours of Conditional Probability of Submarine Detection Around a Sensor Pattern	4-22
4-12	Resource Depletion Chart	4-26
4-13	Resource Depletion Parameter Versus Available Sensors n_t	4-27
4-14	Two Dimentional Utility Space	4-30
5-1	System Concept	5-1

1. OVERVIEW

1.1 Summary

This report describes the design and analysis phase of a program directed toward the specification and demonstration of adaptive decision aiding in airborne anti-submarine warfare (ASW). The approach is based on the application of Perceptronics' decision aiding methodology, developed under previous ONR/ARPA support, to the decision needs of ASW operations including target detection, localization, and tracking. Overall program objectives are as follows:

- (1) To improve effectiveness of sensor deployment and sensor data in airborne ASW operations;
- (2) To contribute to the design of updated and future airborne ASW systems by developing human factors guides for decision aids;
- (3) To develop decision aiding prototype simulation demonstrations;
- (4) To provide a structure for assessing system performance.

The current program focuses on the design for a functional demonstration of adaptive decision aiding methodology as it applies to the decision tasks of the crew of the Navy P-3C ASW aircraft. The purpose of the functional demonstration is to show the potential of decision aiding in current military operational systems. The ASW environment was chosen as a vehicle for demonstration because of the highly critical and time-stressed nature of decision-making tasks surrounding tactical operations. It is in these areas, in which crucial decision-making has a major impact, that adaptive decision aiding methodology can be the most effective.

The specific program objectives are:

- (1) To analyze and define the ASW operational environment and to define the decision situation in terms of decision types, information needs, and operational constraints.
- (2) To define the range of applicability of decision aiding functions in ASW tasks and to specify the system constraints affecting the feasible utilization of these aids.
- (3) To study and experimentally evaluate the effectiveness of the decision aids in simulated ASW operational environments and to develop human factors criteria for implementation.
- (4) To provide guidelines for system integration of ASW/decision aids in realistic operational decision environments and to move toward operational testing and application.

1.2 Approach

1.2.1 The Airborne ASW Problem. Tactical ASW consists of five major functions: intelligence, detection, localization, tracking, and destruction. Intelligence serves to identify the capabilities of classes of submarines and to locate them within a particular ocean basin. Intelligence capabilities include information about the number of submarines in each class, the number and range of missiles (cruise or ballistic), number and type of torpedos, speed and endurance, noise level, and sonar and radar capabilities. Tactical intelligence includes information about the number of submarines out of port, the number in each ocean basin, operating tactics, special vulnerabilities, etc.

In the detection phase of ASW, an expanse of ocean is searched to see if anything is there. The objective of detection is to make initial contact with hostile submarines. A wide range of sensors are used to perform this function, including the following: radar and ECM; radio-frequency direction finders; visual sighting systems; magnetic anomaly detectors; passive acoustic methods such as fixed hydrophone arrays, sonobuoy fields, and surface vessel or submarine mounted passive sonar; and active acoustic methods such as active sonar mounted on surface vessels, submarines, helicopters, and ocean floor sensors.

In the localization phase, an object is assumed to have been detected and the objective is to pinpoint its location and identify what it is. The sensors available for this phase are the same as those used for detection, but because the search is much more directed, the patterns of usage will differ.

The tracking and destruction functions are optional. In peacetime, it is highly likely that a submarine will be continuously tracked once it has been located and identified. In war-time, however, it is far more likely that an attempt will be made to destroy the submarine.

The P-3 aircraft is a flying platform which performs specific ASW tasks and includes all of the major tactical ASW functions except intelligence. The major function of the P-3 system is to establish ASW sonobuoy patterns and to analyze and evaluate the received data. The command and control section of the P-3 system is composed of two main crew positions types: (1) a Tactical Coordination Officer (TACCO), and (2) sensor operators. The crew members control the allocation of sensor resources, the data processing functions that are being performed on the sensor data, and the data display equipment.

The crew functions are divided as follows. The TACCO allocates sensor resources, makes sensor resource decisions, and acts as the group commander. The sensor operators control the data processing functions, control the display functions that are being performed on the data, evaluate the sensor responses, and make decisions regarding the significance of the data.

The decision tasks that are associated with the P-3 crew can be categorized into three types: (1) deployment of sensors, (2) data processing, and (3) sensor data evaluation. Sensor deployments involve the allocation of sensor resources (such as sonobuoys) to the specific environment in which the detection, localization, or other ASW tasks that depend on the sensor data, are being performed. Deployment decisions by the TACCO are based on the data obtained from previous sensor data evaluations, as well as on sensor allocation procedures, sensor availability, and considerations regarding the achievement of optimal sensor response.

A typical P-3 scenario would involve the search of a designated area where intelligence data indicates that a target exists. The mission is structured according to a set of general procedures that govern the modes of sensor allocation pattern, sensor types, and the sequence by which various sensors are allocated as information is acquired. In general, the operation begins with the allocation of inexpensive multi-directional sensors that detect the existence of the target within a certain area. Once the existence of the target is established, higher-capability, higher-cost sensors are used. The decision problem of sensor allocation becomes critical as the sensor resources are depleted, along with fuel supply and mission time. At this stage, careful decisions must be made as each aircraft maneuver is executed. This type of situation is ideal for application of adaptive decision aiding methodology for the following reasons: (1) the decisions are sequential and repetitive in nature, (2) tradeoffs must be made between the cost and the benefit of available resources, (3) a high proficiency level must be maintained over a long period of time, and (4) the decision environment is highly time-stressed.

1.2.2 The ADDAM System Concept. ADDAM consists of an adaptive decision model which continuously observes both the decision environment and the decision maker's (DM's) behavior, learns his decision policy, and makes choice suggestions based on the apparent value of the alternatives to the decision maker.

The adaptiveness of the ADDAM system is realized through the use of a trainable multi-category pattern classifier. As the DM performs the decision task, this on-line estimator observes the operator's choices among the various decision options. The estimator, using event probabilities as inputs, attempts to classify these probability patterns by adjusting utility weights according to an adaptive error correcting algorithm. In this manner, the utility estimator tracks the operator's decision making preferences and learns his utilities. Such an approach has a number of advantages compared to off-line utility estimation. Dynamic estimation observes and models actual behavior rather than responses to hypothetical decisions. It does not interrupt or intrude on the process of decision making; it responds to ongoing changes in task characteristics and operator needs.

ADDAM is used to augment operator performance in two types of related decisions. First, the operator decides on a means of information acquisition. Second, on the basis of information received, he selects an appropriate action alternative. The action decision introduces dynamic properties, because it impacts future information acquisitions. The ADDAM system aids in the information acquisition phase by inferring the operator's utility structure, combining these utilities with estimates of information availability, and recommending the information source with the highest expected utility. Complementary aiding in the action selection phase is given by a probability updating program. Revision of probabilities following information acquisition is computed using a Bayesian approach.

1.3 Summary of Tasks Performed

The following tasks have been completed and are described in detail in this report:

- (1) A detailed analysis was conducted of the ASW environment and the existing critical decision situations. Specifically, the analysis concentrated on the decision tasks of the Tactical Coordination Officer (TACCO) aboard the P-3 ASW aircraft.
- (2) The algorithm for decision aiding in the P-3 environment was developed and is specifically tailored to the decision requirements of the TACCO as he performs his tactical operations.
- (3) A preliminary implementation plan has been developed which will lead to the implementation of the decision aiding algorithm as a functional demonstration at the Naval Air Development Center, Warminster, Pa.

1.4 Report Organization

Chapter 1 has presented an overview of the problems and approach for incorporating adaptive decision aiding methodology into the ASW decision environment. Chapter 2 reviews the ADDAM methodology in greater detail. The decision environment surrounding P-3 operations is described in Chapter 3. Chapter 4 presents the detailed design for the adaptive decision aiding algorithm. Finally, Chapter 5 briefly explains the preliminary implementation plan for the functional demonstration of the decision aids at the Naval Air Development Center (NADC), Warminster, PA.

2. ADAPTIVE AIDING METHODOLOGY

2.1 ADDAM System Overview

Adaptive or goal directed techniques are employed extensively in the ADDAM decision support system. The adaptive methods involve the on-line acquisition of operator decision strategies by computer observation of his behavior. This dynamic modeling is capable of in-task observation of operator decisions made in response to real world probability data. The decision maker's value structure is then computationally inferred through a pattern recognition algorithm, and used as an input to a decision recommendation program. The resulting behavioral model and aid have the advantages of (1) functioning operationally in actual tactical circumstances, (2) adapting to changing task requirements and operator capabilities, and (3) requiring minimal programming complexity. These techniques use pattern recognition or learning algorithms to estimate behavioral parameters. The ensuing models are then used to train, replace, or evaluate the operator. The current work extends this field of work by placing the operator in a real-time interaction with his model. The system both descriptively models and proscriptively aids the operator.

Because the decision model is adaptive, model based decision aiding establishes a complex synergistic relationship between the operator and ADDAM. The system adapts to the human operator's pattern of behavior and, in turn, provides decision aiding which may cause the human to modify his behavior. In a sense, the decision maker is provided with a tool that refines his behavior. Rather than confronting each decision anew, and depending on often fallible processes of recall, recognition, problem structuring, and evaluation, the operator uses logically derived recommendations to guide and condition his responses.

2.2 ADDAM Theoretical Structure

The ADDAM Decision Support System is composed of a combination of three complementary elements -- a set of probability aggregation programs, a dynamic model for tracking operator values for outcomes, and a strategy recommendation algorithm. Each of these aiding subsystems has a major role in augmenting the human functions of problem formulation, analysis, resolution and evaluation.

2.2.1 Probability Aggregation. The first mode of aiding, probability aggregation, is possibly the most established and procedurally defined area of support. This type of aiding is typically based on Bayes' rule, a mathematically appropriate way to revise probability estimates with new information (Edwards, 1962; Johnson and Halpin, 1972; Beach 1975). The technique combines prior probabilities and conditional probability estimates to arrive at posterior probabilities. Bayesian aggregation is used by the ADDAM system to update environmental status and sensor data when new information is received.

2.2.2 Utility Estimation. More difficult are the considerations of perceived gains associated with the decision outcomes. Occasionally, objective values in terms of dollars, ship-equivalents, or other external criteria can be used as criteria for choice. The situation must be exhaustively quantified to justify this type of calculation. For instance, a strategy for action selection based on such objective criteria such as speed, accuracy, or expected value may be relatively easy to derive when system objectives, behavior, and environmental conditions are completely specified. Given the immediate probabilities of obtaining the possible outcomes and given the costs of the consequences, the decision choice with the highest expected value can be selected. Objective performance criteria for the immediate task in most man/machine systems, however, are not well defined, or are only indirectly related to long term system goals. This indeterminacy is

particularly evident in systems operating in dynamic environments, where the results of earlier decisions affect later decisions. Such systems may rely heavily on the operator's subjective evaluation of the situation at hand, and the decisions should be based on measurable subjective preferences (utilities) of the operator.

Numerous techniques are available for assessment of the operator's utilities, ranging from ad hoc procedures to completely axiomatic analysis. The simplest techniques entail eliciting direct expressions of preference along qualitative or quantitative scales. Fishburn (1967) lists more than a dozen such direct methods. Other techniques of utility assessment include the decomposition of complex decisions into hypothetical lotteries, and the use of multivariate methods to analyze large numbers of binary preference expressions to determine underlying factors (Kneppreth, Gustafson, Johnson, and Leifer, 1974).

A major practical limitation to the application of decision theory is the complexity of utility assessment techniques. Most applications require a two-step process. The first step is to assess the decision maker's (DM) utilities, and the second is to apply them to the decision problem. Because it is not feasible to reassess utilities frequently in repetitive tasks, it is assumed that they remain static during this application. Such an assumption might be valid for a "one-shot" decision. However, there is no reason to assume that the DM's utilities remain static during the performance of multi-stage decision tasks. Nor is it reasonable to assume that they remain the same when the context changes from that of a laboratory context to the real world task.

The technique developed in ADDAM for dynamic utility estimation circumvents many of these problems. Dynamic estimation uses the principle of a trainable multi-category pattern classifier to "learn" the operator's utilities for the outcomes of information acquisition decisions (Freedy, Weisbrod, and Weltman, 1973). Such an application of pattern classification

techniques was first suggested by Slagle (1971), who pointed out that the utility function was an evaluation function which could be learned from a person's preferences. The adaptive technique assumes an expected utility maximization paradigm for modeling decision behavior, and uses a pattern recognition algorithm to successively adjust the model to fit observed decision behavior. The underlying expected utility (EU) model assumes that the operator chooses that action whose expected (probability weighted) utility of outcome, is highest (Krantz, Luce, Suppes and Tversky, 1971).

The advantages of the dynamic observation technique are as follows: (1) utilities are estimated non-verbally, without the need for a skilled analyst highly trained in utility estimation techniques. In fact, the decision maker need not be aware that his utilities are being assessed. Utilities can be estimated rapidly and the technique is not limited by the number of possible decision outcomes, (2) The utilities are measured on a common scale and are combinatory. (3) The utility assessment technique responds to changes in values and the utilities are automatically validated by direct comparison with the decision maker's real-world behavior.

2.2.3 Strategy Recommendation. The third element of the ADDAM system, the strategy recommendation program, follows naturally from the probability and utility estimators. With these parameters defined it is a simple matter to recommend individually optimal decisions. The choice with the greatest expected utility is determined and displayed to the operator. The recommendations given are thus based on the operator's own apparent values, and are organized into a normative framework. A certain generality is present in the normative processing, since the recommendations are not restricted to the identical circumstances of the observations used for training. Recurrent observations of the operator actions and circumstances are necessary for estimation of parameters, but these determinations generalize to other circumstances of the same structure.

2.3 Aiding Dynamics

The strategy recommendation algorithm closes a man-computer decision cycle or loop of considerable flexibility and dynamics. The extent of the aiding can be observed by examining the major decision processes of information acquisition and action selection. These processes are diagrammed in Figures 2-1 and 2-2, without aiding. In the information acquisition task, Figure 2-1, the operator receives feedback of the data requested and of the costs of data acquisition. To achieve long term success, he must ascertain what type of behavior led to maximum performance, a difficult task with probabilistically unreliable information sources. He must then use the data obtained to select timely actions (Figure 2-2) and to evaluate his performance using sporadic or noisy performance feedback. This cycle repeats itself as information is converted into action throughout tactical decision making, and because of the dynamic nature of these cycles, errors tend to compound.

2.3.1 Aiding in Information Acquisition. The ADDAM system aids the operator in the information acquisition process by introducing several additional loops. Figure 2-3 shows the augmented structure of information acquisition process, demonstrating both feedforward and feedback loops. The feedforward part is a predictor display. It uses a model of the state transition probabilities to arrive at revised probability estimates of the state of the environment. These probabilities are both displayed to the person and used as inputs to the utility estimation program.

The EU model, comprising the lower feedback loop in Figure 2-3, is the heart of the ADDAM system. The model uses the predicted probabilities of states as inputs, and attempts to match operator behavior by adjusting weights decision-by-decision. These recommendations are not merely the result of calling up previously observed responses. The values are condensed from a variety of observed behaviors and in the recommendations are applied to decision circumstances that may be new to the decision maker.

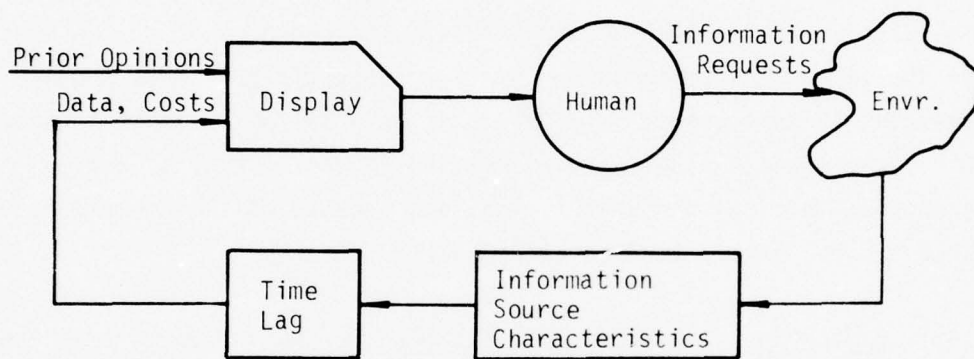

FIGURE 2-1. INFORMATION ACQUISITION

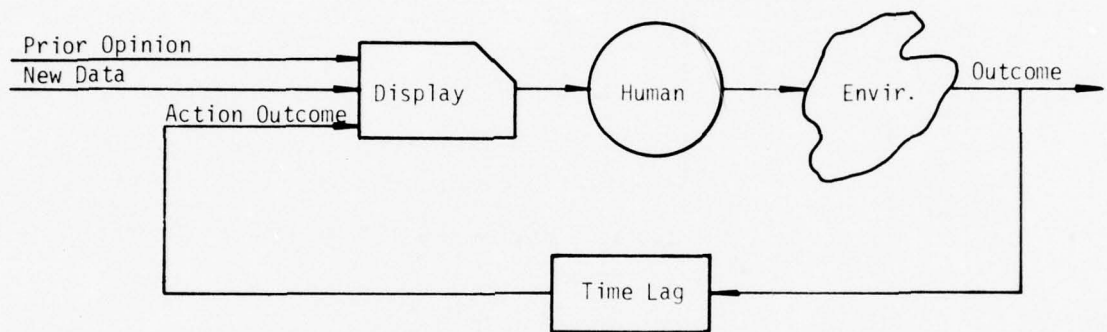

FIGURE 2-2. ACTION SELECTION

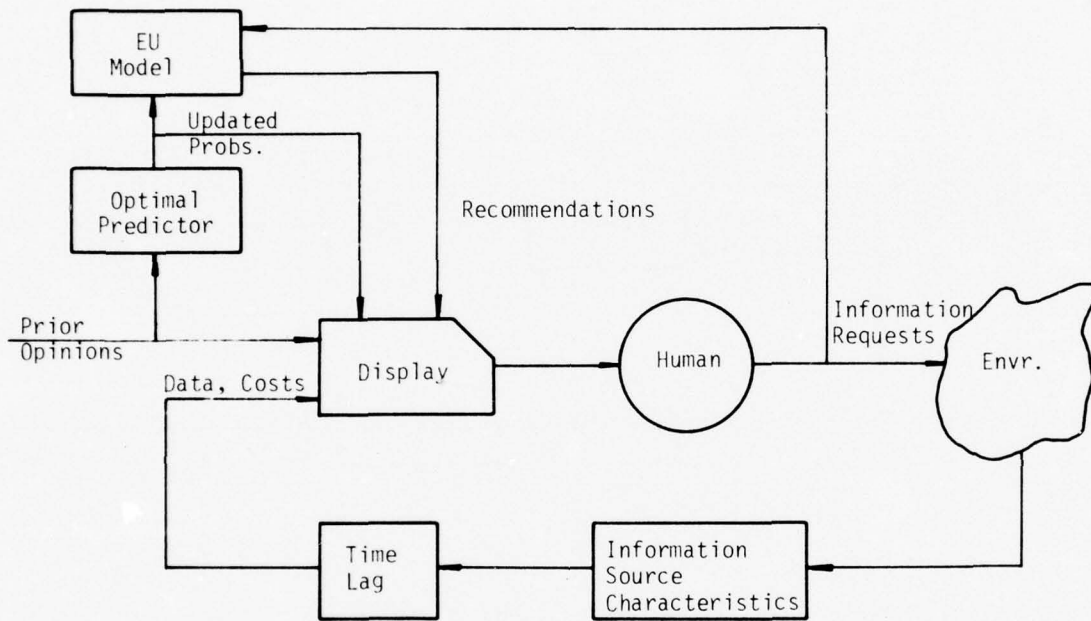

FIGURE 2-3. INFORMATION ACQUISITION WITH AIDING

2.3.2 Aiding in Action Selection. The second major decision process considered in ADDAM, action selection, is similarly amenable to dynamic aiding. Here, however, the aiding is entirely of the feedforward type, as shown in Figure 2-4. Probability aggregation and normative strategy recommendations are again made, but in different ways than in the information acquisition decision. Rather than updating probabilities of outcomes according to transition relations, the prior opinions are Bayesian updated according to the information received. This is a well established and completely deterministic calculation (Rapaport and Wallsten, 1972). It is also assumed that the outcomes of the actions are associated with set objective costs. The revised opinion can then be weighted by the objectivity defined costs for the outcomes and a maximum expected value choice recommended. This is a preprogrammed calculation, and does not require estimation of utilities or use of adaptive processes. If the outcomes could not be objectively quantified, a dynamic utility assessment and EU based recommendation algorithm of the type described earlier could be used.

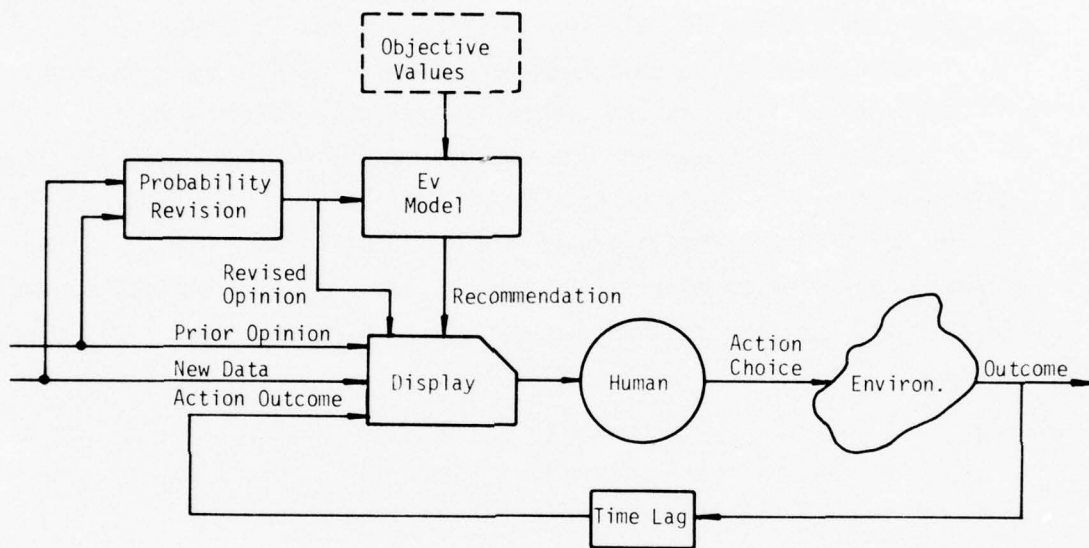

FIGURE 2-4. ACTION SELECTION WITH AIDING

3. THE P-3C ASW ENVIRONMENT

3.1 Overview

This section describes the decision environment around which the aiding model is designed. The analysis is the result of an in-depth study of current ASW operations. A typical peacetime anti-submarine warfare (ASW) mission consists of detecting and tracking an enemy submarine for as long as possible using a specially designed aircraft called a P-3C. The aircraft is equipped with different types of acoustic sonobuoy sensors and a computer system capable of processing tracking information.

The individual responsible for the major decisions aboard the aircraft is the Tactical Coordination Officer (TACCO). He must make decisions concerning (1) the course of the aircraft, (2) the pattern and type of sensors to be dropped, and (3) the probable location of the submarine, etc. These decisions are part of the overall tasks of integration and evaluation of sensor information, management of sensor deployment, and (in wartime) management of weapon deployment.

3.2 The P-3C Aircraft

The Lockheed P-3C ASW aircraft (see Figure 3-1) contains three ASW sensor positions, a navigator position, and the TACCO station in addition to the pilot and co-pilot. The acoustic sensor stations are Sensor Station 1 (SS1) and Sensor Station 2 (SS2). These stations are capable of listening either actively or passively for submarine sounds (passive listening) or sonar echos (active listening) in the water. They are linked via radio with the sonobuoys deployed. Sensor Station 3 (SS3) is the Magnetic Anomaly Detector (MAD) station and the radar station.

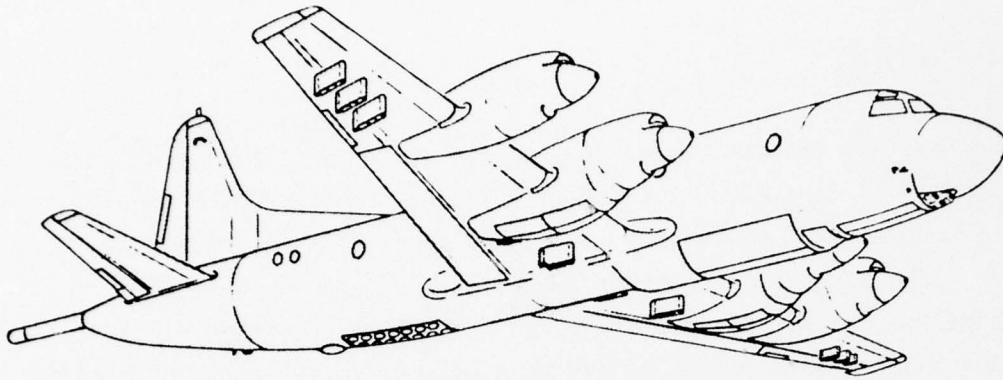

P-3C

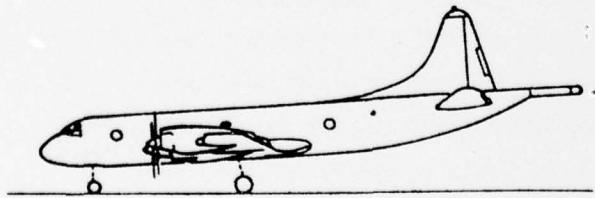
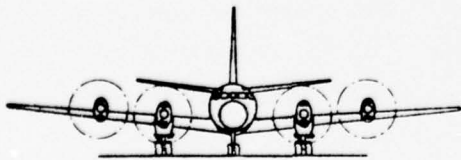
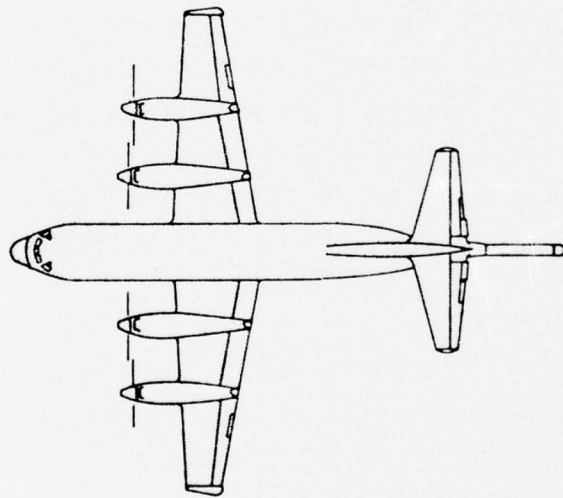

FIGURE 3-1. THE P-3C AIRCRAFT

HH 3552
F141-P(3)-1-68

P-3C CREW STATIONS

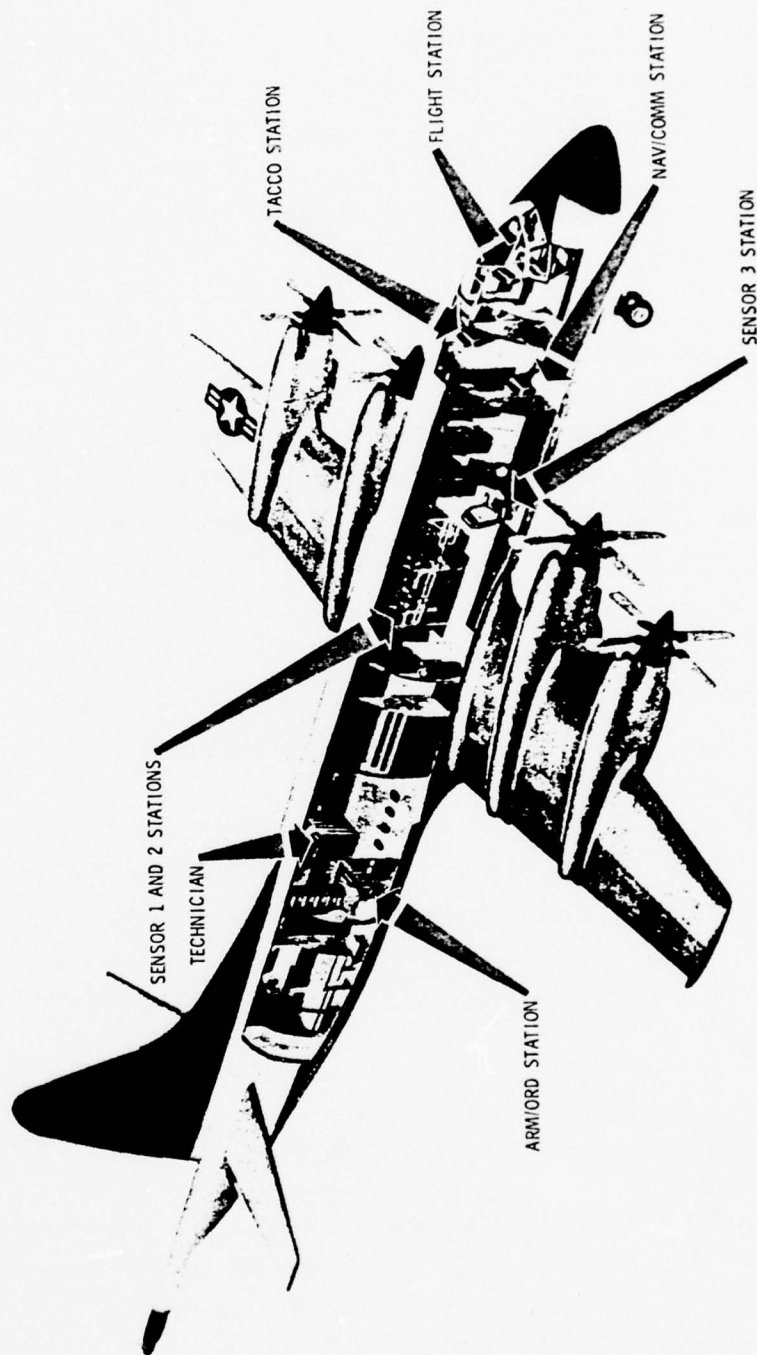

FIGURE 3-1 (continued)

The P-3C acts as the sensor and weapon platform from which the ASW mission is conducted. The aircraft carries a fixed number of sonobuoys and (in wartime) ASW weapons. The TACCO is in charge of the ASW search, detection, localization, and tracking (as well as attacking if in wartime) of hostile submarines. The navigator provides mission navigation information and acts as communications officer during the mission. The SS1, SS2, and SS3 operators are enlisted men who operate their respective sensor equipment.

3.3 The P-3C ASW Mission

A P-3C ASW mission consists of four phases: (1) search, (2) classification, (3) localization, and (4) attack (if in wartime) or tracking and gaining intelligence (if in peacetime). A mission begins with an intelligence report indicating that a submarine is in some area of the ocean. This initial area (and all subsequent areas in which the submarine is thought to be) is called an "area of probability". The ASW mission objective is to reduce this initial area of probability -- which starts out very large -- until it is small enough to successfully attack the submarine.

Each mission begins with a preflight planning session which consists of the following planning information and decisions:

- | | |
|------------------------|---|
| 1. Target information | Type of target (i.e., diesel, nuclear) |
| 2. Detection range | A function of the target and the water conditions in the area of probability |
| 3. Area to be searched | Identifies the area of the ocean to be searched (i.e., the initial area of probability) |

- | | |
|---|--|
| 4. Number of sonobuoys | The aircraft has only a certain number of sonobuoys and a certain number of radio channels that can be used to communicate with the sonobuoys. |
| 5. Sonobuoy lifetime and depth settings | Each sonobuoy may have different depth and lifetime settings. |
| 6. Types of sonobuoys | Quantities of each type to be taken on mission. |

Once the preflight planning is completed, the P-3C departs for the initial area of probability, and the ASW mission begins. The search (and subsequent phases) are mostly acoustic. Visual and radar searches are infrequently used and MAD is used only in the tracking stages. (In the U.S. fleet, a training mission scenario is developed. U.S. submarines move into an area of probability and behave like enemy submarines. In the training center, fleet mission exercises are simulated by computer). During a mission, there are three types of sonobuoys that can be used: (1) LOFAR which is a general passive, non-directional sonobuoy and not very expensive to use, (2) DIFAR which is passive and provides a bearing to a target but is about five times as expensive to use as LOFAR buoys, and (3) active sonobuoys. During a mission, the TACCO must decide how to place the sonobuoys and what type to use. He must consider how many of each type are on board, their lifetimes, depth settings, and quantities of each. After takeoff, most of the buoys cannot be changed. The settings decided upon in the preflight planning session are fixed in all but a few of the sonobuoys. Only these few can be changed in flight.

The size of the area of probability and the range at which a submarine can be detected influences the types of sonobuoy used. The range of detection is influenced by water conditions and target type. This information is normally provided during preflight briefings. Once in an area of probability, however, the ASW crew can drop a bathothermoby to test the actual water conditions in the area. If they differ from the preflight predictions, the crew must revise their ideas to take into account how this new water condition information will effect the detection range. During the mission at the two acoustic sensor stations (SS1 and SS2) each operator (one at a station) monitors a fixed number of sonobuoys. In the passive mode of operation, they use the sonobuoys via the radio link to the P-3C to "listen" for noises of various frequencies in the water in the area of probability. The frequency spectrum and any frequencies that are heard are printed out on a LOFARGRAM and the operators scan the "grams" to see if there are any frequencies that could be associated with a submarine. The capabilities of the men operating the SS1 and SS2 stations are critical. They must recognize sound patterns and decide if they have a contact or not, and they must perform this vigilance task over a six-hour mission. Recognizing a contact is further complicated when sensor feedback from different sensors (sonobuoys) gives contradictory information. The best of all worlds is, of course, when all sensor feedback provides similar indications.

The mission really begins full force once an initial detection and classification occurs. The TACCO must then decide what course of action to take. What is the source of this sound? Must passive or active sonobuoys be used? (Often these questions are answered by fleet policies.) How is the target to be classified? These are examples of the types of questions that run through the TACCO's mind during the mission.

3.4 The TACCO Decision Task

Once the TACCO has dropped sonobuoys, some critical decisions must be made. He must decide what the sensor feedback or lack of it means. Conflicting feedback information can affect decisions. For example, items that influence the noise factor in sensor feedback are bottom bounce, conflicting bearings, loss of contact, (the submarine may hide behind undersea mountains, etc.), errors in sonobuoy bearings, and submarine course and speed changes. If a contact is lost in the passive search phase, one option is to go active (if permitted by fleet policies). In the localization and tracking phase, the critical factor is the time to make a decision in addition to the "rightness" of the decision. An incorrect or slow decision can cause a contact to be lost.

During an ASW mission, the utility of the various sensors may change. For example, early in the search phase, LOFAR sonobuoys are very valuable as sensors. Later in the localization or tracking phases, LOFAR buoys are much less valuable and DIFAR buoys become the valued sensors. This clearly indicated that values are dynamic during an ASW mission, and suggests that adaptive decision aiding can be extremely helpful. Static decision aids cannot account for value changes as they occur, based on feedback patterns from the sensors in all the infinite variations that are possible.

3.5 Computational Aids

A sophisticated computational and information display system is available on the P-3C aircraft for the purpose of making the tasks of the TACCO more effective. The heart of the system is the TACCO display screen which summarizes sensor information and provides a visual mechanism for making decisions. Figure 3-2 shows a schematic of the

TACCO STATION ARRANGEMENT (TYPICAL)

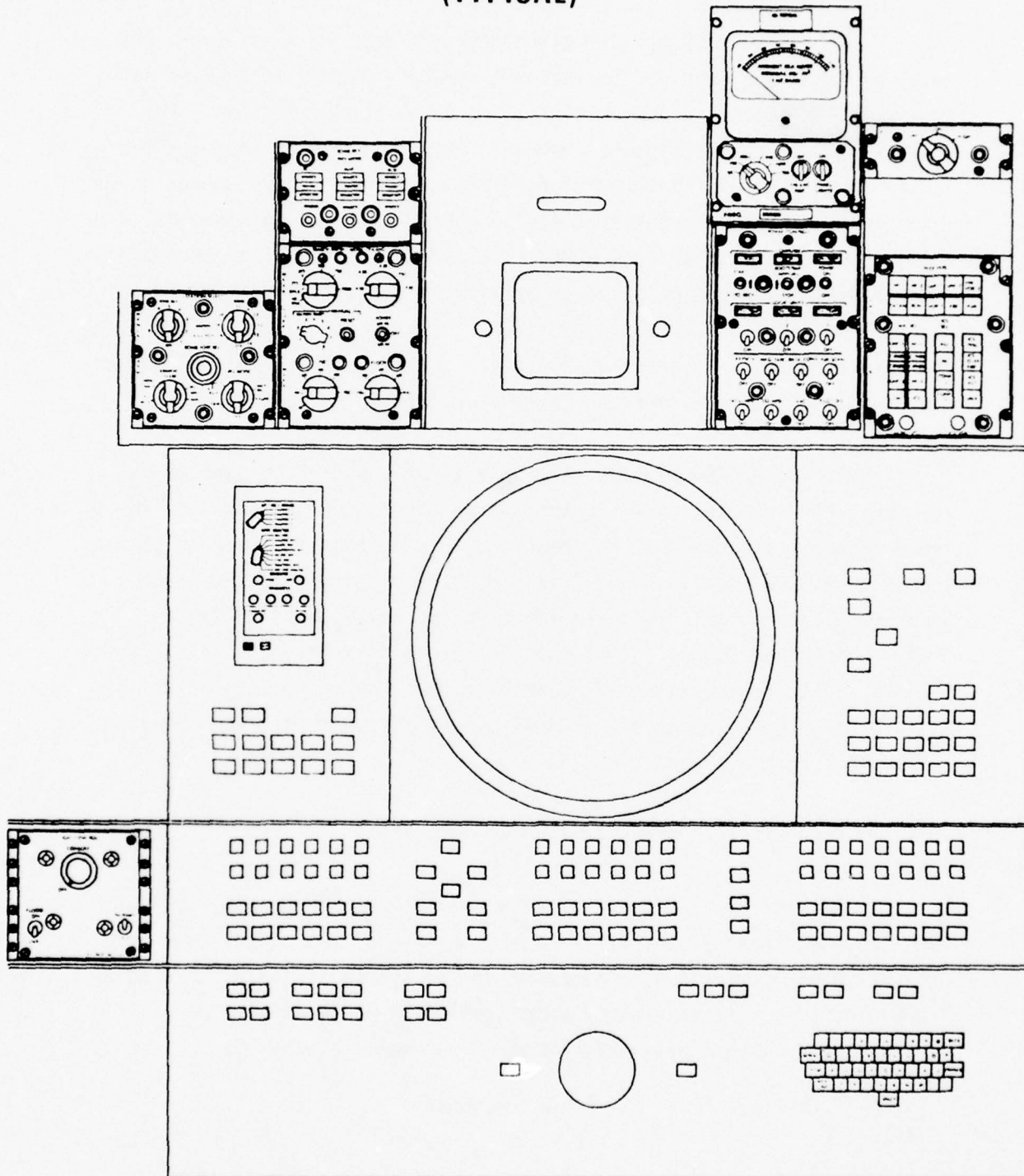

FIGURE 3-2. TACCO STATION

HA 3631
F141-3-1.1-8-001

TACCO station with the display screen in the center. The screen represents a designated area of the ocean around the current location of the aircraft. Information received from deployed acoustic sensors is initially entered into the computer system by the sensor operators at their individual stations. This information appears on the TACCO display screen as bearing lines emanating from previously indicated sensor drop point locations. (See Figure 3-2) The TACCO must use the various computational and display aids provided to plan the allocation of new sensors so that contact with the submarine can be maintained as long as possible.

The primary computational aid is the "tracking bug" which predicts the most probable location of the submarine based on current information. The tracking bug moves on the screen in real-time and, consequently, is a continuously updated estimate. In order to produce the tracking bug, sensor information must be selected and entered by the TACCO. This is done by selecting promising intersections of bearing lines that appear on the screen and marking them for data entry. The intersections are called "fixes" and represent possible locations of the submarine based on pairs of sensor contacts. However, because of errors, it is rarely the case that all pairs of sensors will intersect at the same point. Thus, it is up to the TACCO to choose those fixes that seem most reliable and request a tracking bug based on this choice. Possible errors can arise from (1) sensor failure, (2) bearing errors, (3) signal reflections, and (4) operator errors, etc.

3.6 The P-3C Simulator Update System

The P-3C training simulator is an exact replica of the actual P-3C aircraft stations along with computer support for simulating the ASW mission environment. The latest additions to the simulator (called

the "update" system) contain many improved data processing and display features. The following sections summarize these features and their effect on the TACCO decision making task.

3.6.1 Probability Contour. A probability contour is a single ellipse that appears on the TACCO display screen. It is based on the probability of a submarine located at the intersection of two or more sensor bearings. The contour is not based solely on where the submarine itself is or could be. The contour is a combination of both sensor feedback probabilities and where the sub is believed to be. This fact is driven home visually by the fact that if a sensor pattern is changed to compute the area of probability, the contour can change dramatically in shape depending on the choice of sensors. The contour updates itself as a function of time and sensor "fixes". The TACCO can call for the contour to be displayed and can choose the probability (.2, .5, .8, or whatever) and the size of the displayed probability contour changes accordingly. The contour is based on the sensors and can be thought of as a joint probability density function (PDF) about sensor bearings where the actual sensor bearing is the mean of a normal distribution about that bearing. The area of probability gets smaller as the sensor fixes get better and more frequent. If a MAD contact is made, the area shrinks dramatically since MAD contacts provide extremely accurate locations.

3.6.2 The Track-Fix. The update version has a built-in track fix feature. In the previous version, the TACCO had to find the intersection of two bearing lines by himself visually. In the update system, the intersection is found automatically by the computer, and shows an "x" on the TACCO display screen. He must then decide whether or not to enter this fix into the computer. After a series of two or three fixes are plotted, the computer generates the tracking bug.

3.6.3 Buoy Pattern Aids. After exchanging some information with the computer system and indicating some points on the TACCO display screen, the computer will automatically place the buoys in a pattern and designate the fly-to points for the pilot.

For example, in order to construct a "wedge" pattern, the TACCO is not required to enter data for each sonobuoy individually. He need only enter the parameters of the wedge, such as (1) anchor location, (2) spread angle, (3) orientation, (4) number of buoys, and (5) buoy spacing. These types of pattern aids also exist for the "barrier" pattern (straight line) and the "entrapment" pattern (circle).

3.6.4 MAD Detection Circle. This feature was in the older version and retained in the update. The MAD detection circle is a screen-displayed circle around the aircraft that can be set as a function of height and probability of detection. This is helpful when the probability contour gets small and the MAD detection circle is large enough to overlap the contour. MAD prediction is then possible and is similar to tracking bug prediction. It is simply a prediction of location of the submarine based on previous MAD contacts.

3.6.5 SS1 and SS2 Features. SS1 and SS2 operators now have a CRT to display their sonobuoy patterns and sensor bearings. They can also assign a confidence number for DIFAR bearings on the range of 1 to 9. The decision rule for assigning confidence numbers has not as yet been established in operational P-3C missions.

4. THE P-3 ADAPTIVE DECISION AIDING MODEL

4.1 Overview

The adaptive decision aiding methodology is intended to aid in the passive tracking phase of the ASW task. The phase can be described as a decision cycle shown in Figure 4-1. The TACCO receives information from previously deployed sensors, integrates and evaluates this information, makes his best estimate of the submarine motion, and decides where to optimally drop the next pattern of sensors so that the tracking be continued as long as possible with the least amount of resources expended. This cycle will be described in detail and the decisions to be made in the process will be indicated.

The cycle begins when the TACCO receives information from the previously deployed sensors (step A). The SENSO (sensor operator) -- who filters the raw information coming from the sensing devices -- presents the submarine contact information as directed bearings and range circles on the TACCO's main data display screen.

The TACCO (step B) evaluates the incoming data and integrates his assessment of the situation by placing "fixes" at the bearing line intersections he believes to be true submarine locations. If he needs more information, he can prompt the SENSO to obtain more data from any sonobuoy in the water. The decisions he must make at this stage are: (1) which signal is a true submarine signal, (2) which intersection of bearing lines should be a fix, and (3) when to stop asking for more information and go to the stage.

In step C he makes, with the aid of the computer system, the best estimate of the current submarine location. This is given by the system as a probability distribution map which is calculated from the TACCO assessment

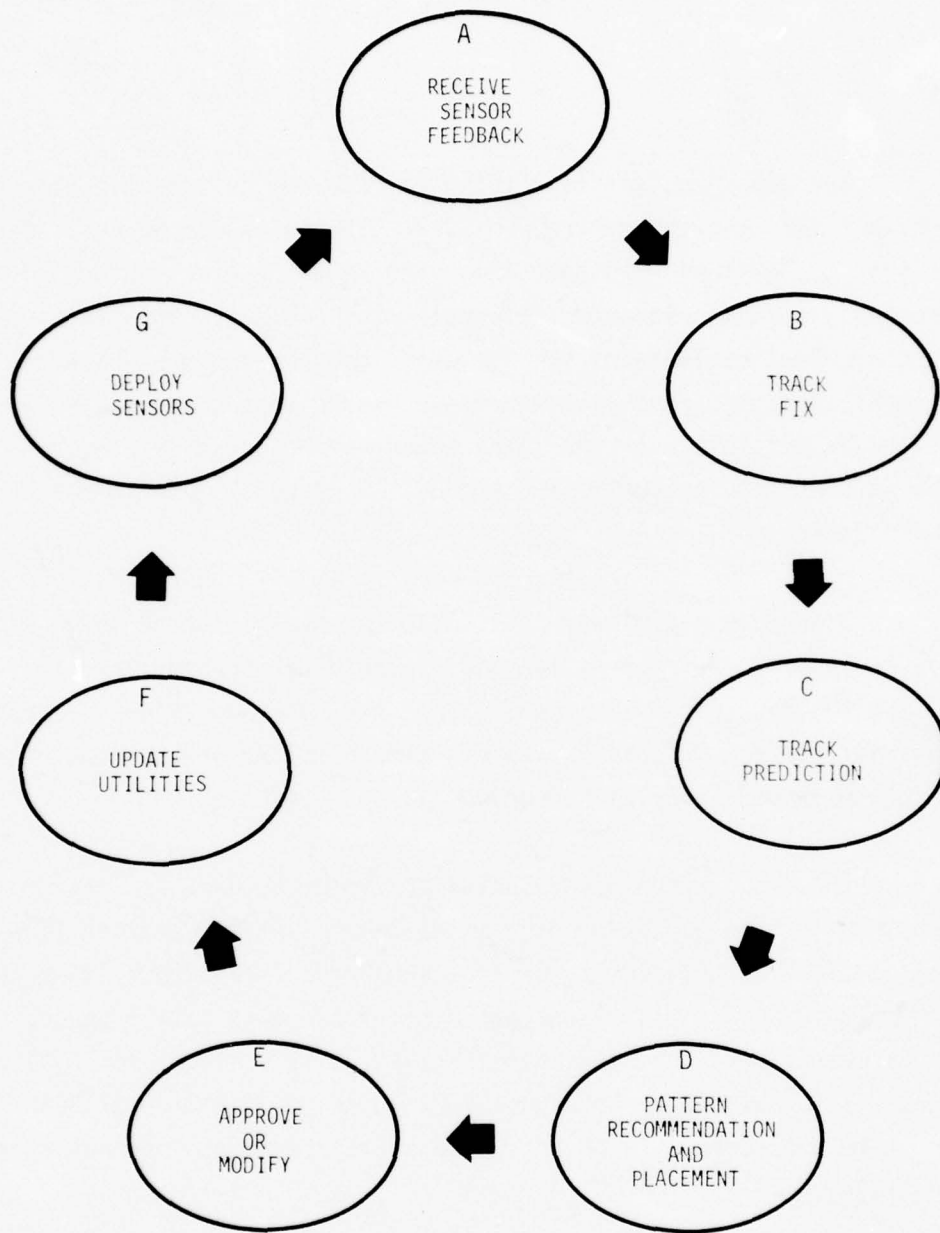

FIGURE 4-1. TACCO TASK CYCLE

of the tracks and from apriori statistical information on submarine behavior. It represents the probability that the submarine will be at various locations at any given time. The most likely location is displayed as a tracking "bug" and is updated in real time.

Step D comprises the decision aiding portion of the cycle. The ADDAM system calculates the optimal positions for each sensor pattern in the decision space and presents one of the patterns as a recommendation thus relieving the TACCO from this central decision. The recommendation is consistent via the adaptive model with (1) the past performance of the TACCO in similar situations, (2) the determined probability distribution of the projected submarine location, (3) the current environmental situation, and (4) the capabilities of the sensors used in the pattern. The recommendation appears on the screen as a text message indicating the pattern type and the number of buoys to be deployed. Upon request, the TACCO receives a display of the pattern superimposed on the map of the search area.

It is now incumbent upon the TACCO to approve or reject the recommended pattern (step E). If the TACCO rejects the pattern, he must allocate his own pattern of sensors manually. This manual allocation will, of course, follow established standard procedures as they now exist. In either case, the internal decision parameters are updated to reflect the TACCO's preferred strategy (step F).

The final step (G) of the decision task cycle is the actual deployment of sensors into the ocean. With the completion of this action, the cycle begins again when new contact information is received.

4.2 Decision Space

The decision space is the set of alternative from which the TACCO has to make his choice. From all of the possible decisions confronting the TACCO in his submarine tracking task, the decision space has been reduced through detailed analysis and interviews with experienced TACCOs to two critical variables:

- (1) Sensor pattern type
- (2) Number of sensors in the pattern.

TACCOs generally do not drop individual sensors into the water except in special cases. The basic unit for sensor placement is a pattern. A basic experimental set of patterns has been developed for the decision aiding prototype system as one of the dimensions of the decision space. The basic pattern types which will be permitted in the decision aiding model are the following (see Figure 4-2).

- (1) Tri-Tac
- (2) Barrier
- (3) Wedge
- (4) Entrapment

4.2.1 Tri-Tac. The Tri-Tac pattern is a group of three sonobuoys placed in an equilateral triangle configuration. One of the buoys is placed at the best current estimate of the submarine's location and the other two are placed so that the submarine will travel between them if it proceeds on a straightline course. This pattern tends to be used early in the tracking phase of the mission when the submarine location is known through intelligence data to get quick initial estimate of the submarine's behavior without expending a great many sonobuoys.

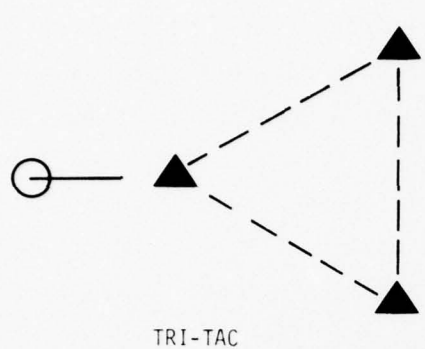

TRI-TAC

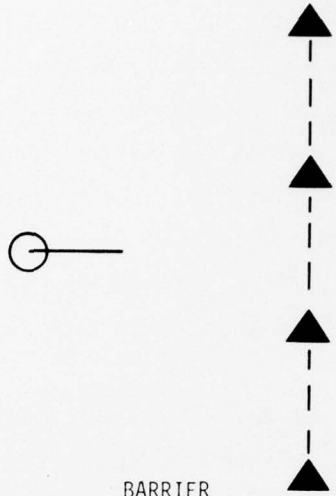

BARRIER

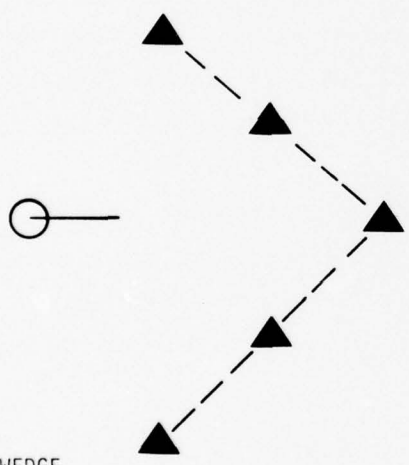

WEDGE

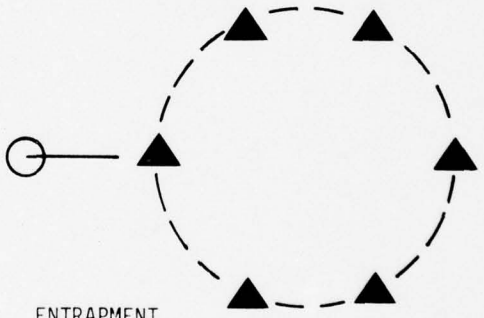

ENTRAPMENT

FIGURE 4-2. THE MAJOR PATTERN GROUPS

4.2.2 Barrier. The Barrier pattern is a linear row of sonobuoys centered on the submarine's predicted path. The pattern usually consists of four or five buoys equally spaced and, on rare occasions, will contain as few as three or as many as eight. The pattern is perpendicular to the submarine's course so that the angles of contact bearings will be as orthogonal to each other as possible. The parameters required to specify a barrier are (1) anchor location, (2) orientation, (3) number of buoys, and (4) buoy spacing. These parameters must be specified by the TACCO in addition to information about buoy type, depth setting, and lifetime.

4.2.3 Wedge. The Wedge pattern is normally used when the submarine's course and speed is known to a greater degree of accuracy. The wedge consists of from three to eight sonobuoys placed in two straight lines intersecting at an apex that is directly in the path of the submarine and oriented so that contacts will be as orthogonal as possible. The parameters required for wedge specification are as follows: (1) anchor (apex) location, (2) orientation, (3) acute angle, (4) number of buoys, and (5) buoy spacing.

4.2.4 Entrapment. The Entrapment pattern is a circle of sonobuoys placed so that the center of the circle and one of the sonobuoys are directly in the path of the submarine. The pattern may contain from four to eight sensors. The necessary parameters are (1) the center of the circle, (2) the radius, and (3) the number of buoys.

4.2.5 Pattern Characteristics. As described above, the decision space of sensor patterns has two major dimensions: (1) pattern type and (2) number of buoys. The combination of 4 pattern types with a choice of 6 sensor densities (3 to 8) makes 24 possible decision alternatives in all. However, it is a unique characteristic of the tri-tac pattern that it always contains exactly three sonobuoys. Furthermore, the entrapment always contains more than three buoys. Thus, the total decision space consist of 18 distinct decision alternatives (See Figure 4-3). The

PATTERN	NUMBER OF SONOBUOYS					
	3	4	5	6	7	8
Tri-Tac	*					
Barrier	*	*	*	*	*	*
Wedge	*	*	*	*	*	*
Entrapment (circle)		*	*	*	*	*

FIGURE 4-3. THE DECISION SPACE

decision aiding recommendations to the TACCO will be selected from this decision space. The sensor patterns have, of course, many more dimensions than pattern type and sensor density. Optional location, sensor spacing, life time, and depth settings are all necessary information, but are not included in the decision recommendation space.

4.3 The Adaptive Utility Model

The P-3C decision aiding algorithm is based on the ADDAM decision model developed over the past three years at Perceptronics. (Freedy, Davis, Steeb, Samet, and Gardiner, 1976). ADDAM decision aiding algorithms were modified to accommodate the increased complexity of the realistic P-3 ASW problem. Sensor patterns are used as the basic decision choice and critical factors such as sensor capabilities, sensor errors, tracking strategies, environmental conditions, and human factors were analyzed and incorporated into the developed algorithms.

The dynamic utility estimation used by ADDAM is based on a trainable pattern classifier. As the TACCO performs the decision tasks, the on-line utility estimator observes his choices among the R possible decision options available to him. (R=18 in the implemented model). His choice is viewed as a process of classifying patterns of event probabilities which are calculated automatically from available information on sensor capabilities and current submarine location. The utility estimator then attempts to classify the event probability patterns by using a maximum expected utility rule as the discriminant function. These classifications are compared with the TACCO's decision and, whenever they are incorrect, an adaptive error correcting training algorithm is used to adjust the utilities. In this manner, the utility estimator "tracks" the TACCO's decision making and "learns" his utilities. A more detailed discussion of the adaptive decision model and the training algorithm may be found in Freedy, Davis, Steeb, Samet and Gardiner, 1976.

An important prerequisite to the application of decision aiding in the ASW environment is a realistic structuring of the decision process. In Figure 4-4, the decision task is presented as a decision tree. At the initial decision node on the left, the TACCO has to decide which alternative pattern A_i to deploy so that his task of continuous submarine tracking will be performed efficiently. This decision is based on maximization of the expected utility. For each alternative choice there are three possible outcomes:

- (1) The pattern deployed will detect the submarine. (U_1)
- (2) The pattern will fail to detect the submarine. (U_2)
- (3) The sensors will issue false signals. (U_3)

The probability of occurrence of each outcome is calculated automatically according to the equations in Section 4.5. The fourth outcome (U_4) is a "pseudo-outcome" modeling the amount of resources depleted by dropping the particular pattern of sensors. As shall be shown later, this parameter will be entered formally as an additional outcome with an associated value analogous to a probability.

Utilities are numbers which characterize a decision maker's value of a particular outcome. They can be estimated only within the context of a particular decision model. In the P-3 model, the TACCO has an internal value associated with continuation of successful tracking of the enemy submarine, a corresponding negative value for failure of detection, etc. The expected utility model asserts that the TACCO will choose the alternative which will maximize his expected utility. The expected utility of outcome j is:

$$EU_j = \sum_{i=1}^4 p_i U_i$$

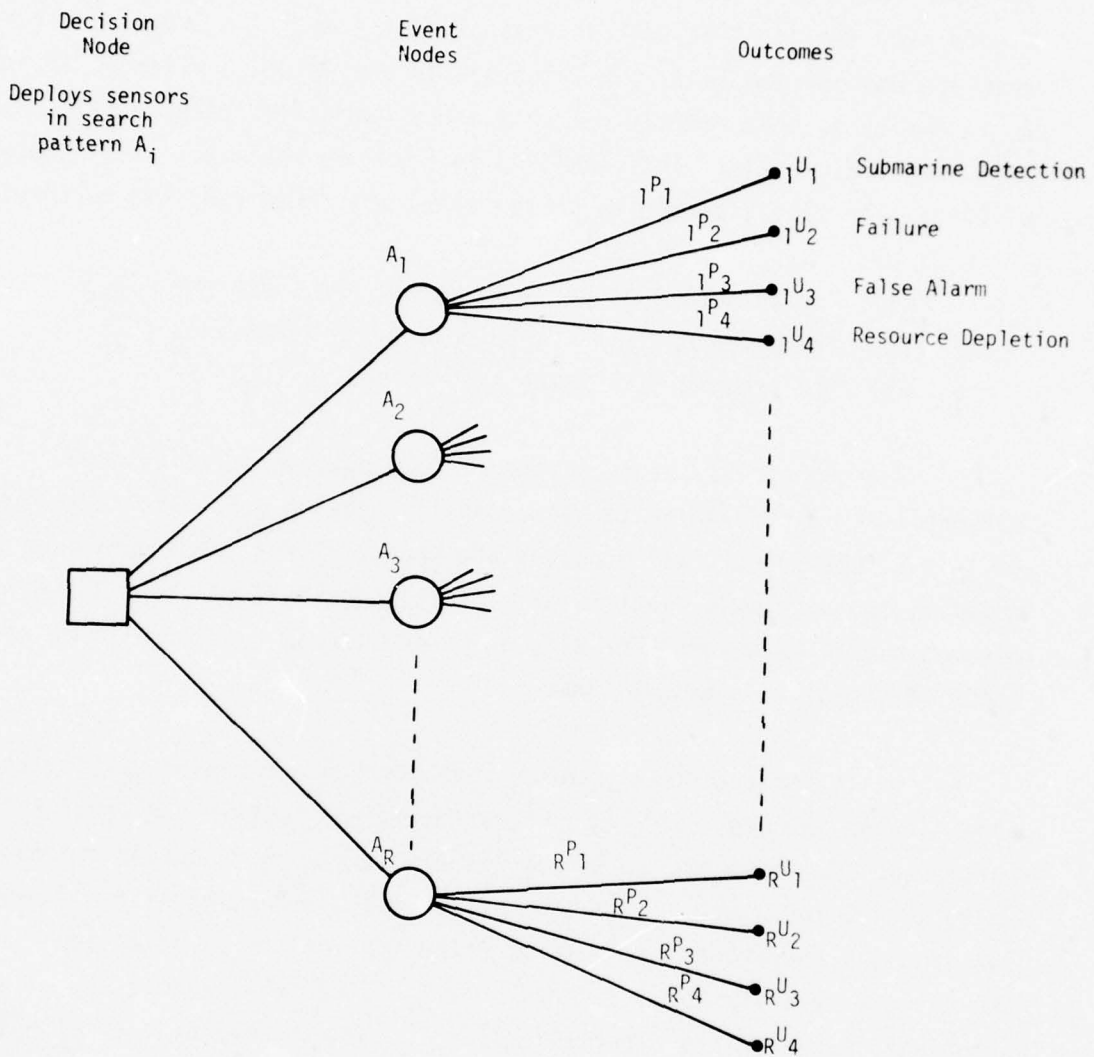

FIGURE 4-4. THE BASIC UTILITY DECISION MODEL

and his choice is alternative j such that:

$$\text{choice } j = \text{MAX}_j^{-1} EU_j$$

Initially, each alternative member of the decision space has a different vector of utilities associated with:

$$U_j = ({}_jU_1, {}_jU_2, {}_jU_3, {}_jU_4)$$

They represent TACCO's personal preferences for each outcome of each pattern in the decision space and depend on various external variables such as weather conditions, submarine type, sea conditions, etc. In the P-3 model, the environmental variations are extracted from the adaptively varying part of the model. A different set of utilities is assigned to each combination of state variables. Once the state variations have been extracted, the decision tree can be simplified into the form shown in Figure 4-5. Since all choices of patterns have the same set of outcomes for a given state of the environment, the utility of each outcome does not depend on which sensor pattern is dropped to obtain it. (The exact integration of state variables into the model is explained in Section 4.6). The model now becomes similar to a multiattribute utility MAU model. A detailed analysis of MAU models is given in Samet, Weltman and Davis (1977). The expected utility equation for each pattern has a single set of utilities for the various outcomes which are weighed by the probabilities of their occurrence. This is analogous to a multiattribute model which essentially conceptualizes the value of an alternative as a multi-dimensional entity which can be decomposed into a common set of measurable attributes. The model computes an aggregate multiattribute utility as a weighed sum of each attribute level A_i multiplied by the importance or utility of the attribute U_i . The calculated MAU of an alternative is used as the selection criterion.

Decision
Node

Event
Nodes

Outcomes

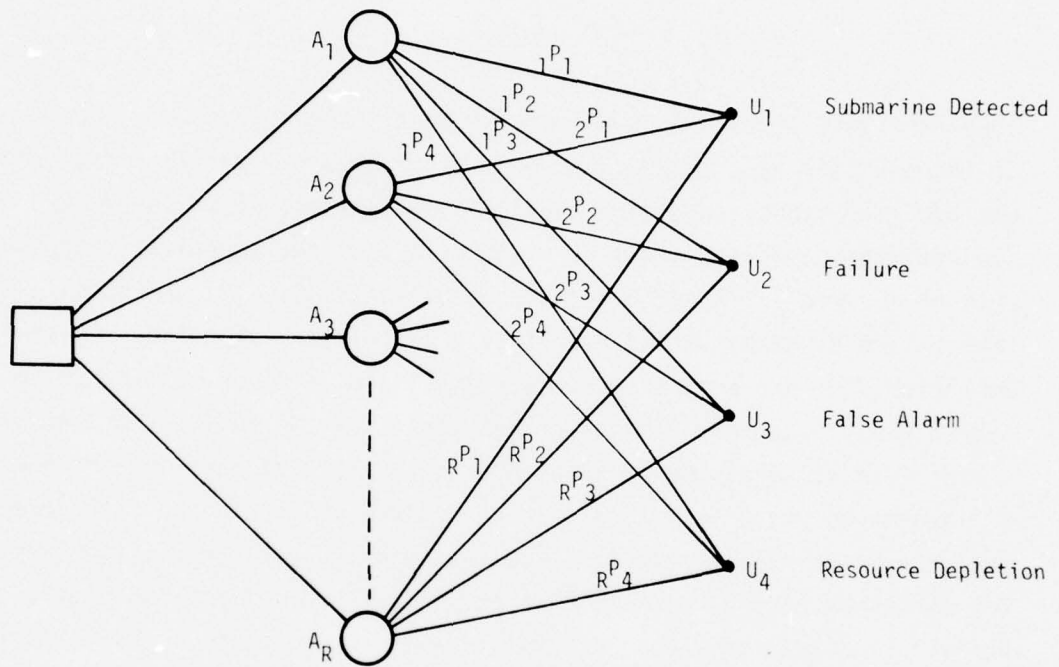

FIGURE 4-5. THE MODIFIED UTILITY MODEL

$$MAU_j = \sum_{i=1}^k A_{ji} U_i \quad V_j = 1, \dots, R$$

In the P-3 model, the probabilities P_{ji} play the role of the attribute levels A_{ji} . Carrying the analogy further, the resource depletion parameter is considered to be one of the utilities and represents the amount of resources depleted by dropping the particular sensor pattern relative to the optimal rate of resource depletion.

4.4 The Training Algorithm

The training algorithm is a linear multicategory pattern classifier. Using a fractional correction factor, it traverses cyclically through the schematic diagram of Figure 4-6. On each trial, the model uses the previously calculated weights U_i for each attribute i to compute the expected utility EU_j for each pattern in the decision space:

$$EU_j = \sum_{i=1}^4 P_{ji} U_i$$

The probabilities P_{ji} are derived from previously known facts about the sensors, their reliability, coverage capability, etc. These probabilities are presented to the TACCO for analysis so that he will base his choice on the same information set. The model then assumes that the TACCO will always prefer to deploy the sensor pattern with the maximum EU value. After the selection, TACCO's choice and the model prediction are compared. If the prediction is correct, i.e., the TACCO chooses the pattern with the highest EU in the model, no adjustments are made to the utility weights. However, if the TACCO chooses a sensor pattern with a EU less than that of the predicted pattern, the model adjusts the utility weights using a correcting vector which is the difference between the probability vector of the chosen pattern and that of the predicted one. In this manner, the utility estimator is "shifted" in the direction of the vector probabilities that

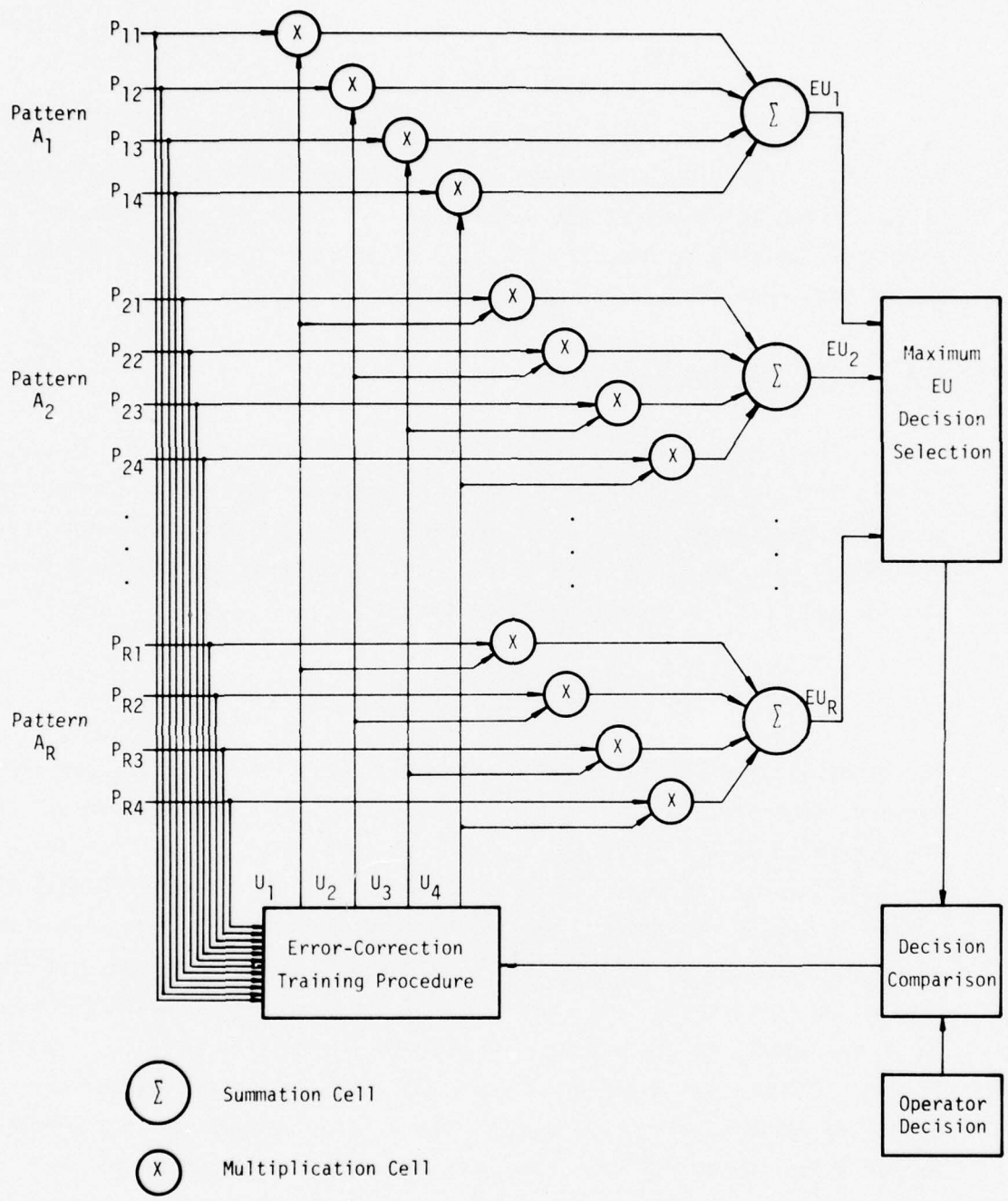

FIGURE 4-6. DECISION MODEL STRUCTURE

it should predict, and away from the vector it did predict. The training rule used to adjust the utilities of each outcome is illustrated in Figure 4-7. The correction factor controls the speed of convergence and will be determined by experimentation.

The vector of utilities is initialized arbitrarily with all utilities equal to 1. It is guaranteed to converge to a solution vector if such a solution exists. That is, if the TACCO is behaving rationally, the model is guaranteed to find his internal values.

There are two phases in the training algorithm behavior which alternate according to a parameter θ representing the level of confidence the algorithm has about the TACCO's behavior. One is the "training phase" and the other is the "predictive phase". The effect of the two phases is that when θ is low, the system does not recommend a solution to the TACCO. When θ is high, it presents that element of the decision space with the maximum EU as its recommendation.

The training phase takes place at the beginning of system use when the utilities have not yet had the chance to converge to a stable solution. The adaptive algorithm is bound, then, to make many prediction errors. In such times the system should not influence the TACCO by presenting erroneous predictions. Internally, the system performs the training process as given above. The training phase is defined by

$$\theta \leq 0.7 \text{ where } \theta = \frac{n}{10}$$

where n is the number of correct prediction in the most recent 10 trials. When the confidence level goes above the specified threshold, the predictive phase begins. The system continues to apply the training algorithm but it also presents the TACCO with a recommendation: the pattern choice with the

Adjusted Weight \hat{U}_i		Previous Weight U_i		Adjusted Factor λ		Probability Vector of Chosen Pattern P_{ci}		Probability Vector of Predicted Pattern P_{pi}
\hat{U}_1	=	U_1	+	λ	.	$(P_{c1}$	-	$P_{p1})$
\hat{U}_2	=	U_2	+	λ	.	$(P_{c2}$	-	$P_{p2})$
\hat{U}_3	=	U_3	+	λ	.	$(P_{c3}$	-	$P_{p3})$
\hat{U}_4	=	U_4	+	λ	.	$(P_{c4}$	-	$P_{p4})$

FIGURE 4-7. THE TRAINING ALGORITHM

maximum value of EU. The TACCO has the option to accept or reject this recommendation and the system will apply the error correcting algorithm accordingly.

4.5 Probabilistic Models

4.5.1 Submarine Detection. The probabilities which are used in the adaptive model are calculated from a probabilistic model of the submarine motion and sensor coverage capabilities. From the current submarine motion and its most recent behavior, a probability distribution $P_S(x,y,t_1)$ of submarine location at time t_1 is calculated. t_1 is the time of the next pattern drop and the distribution P_S is the a priori probability of submarine motion derived from general and expert knowledge of submarine behavior. Given that the submarine is at location (x,y) and the pattern i is deployed, there is a probability $\beta_i(x,y)$ that the sensors will fail to detect the moving submarine. This is naturally a function of sensor sensitivity, sea conditions, submarine type, and the distance of location (x,y) from the pattern. The events of the submarine being at different locations at time t_1 are independent events so we can calculate the global probability of detecting the submarine by sensor pattern i with the formula:

$$P_{i1} = \int_{xy} P_S(x,y) [1-\beta_i(x,y)] dx dy$$

where the integration is done over the whole relevant area. The probability of pattern i failing to detect the submarine is the complementary event:

$$P_{i2} = 1 - P_{i1}$$

For example, assume a simplified probability distribution of submarine location is shown in Figure 4-8. The rectangular areas show three possible future submarine positions with a corresponding probability associated with each. D_1 and D_2 are the areas in which pattern #1 and pattern #2 will

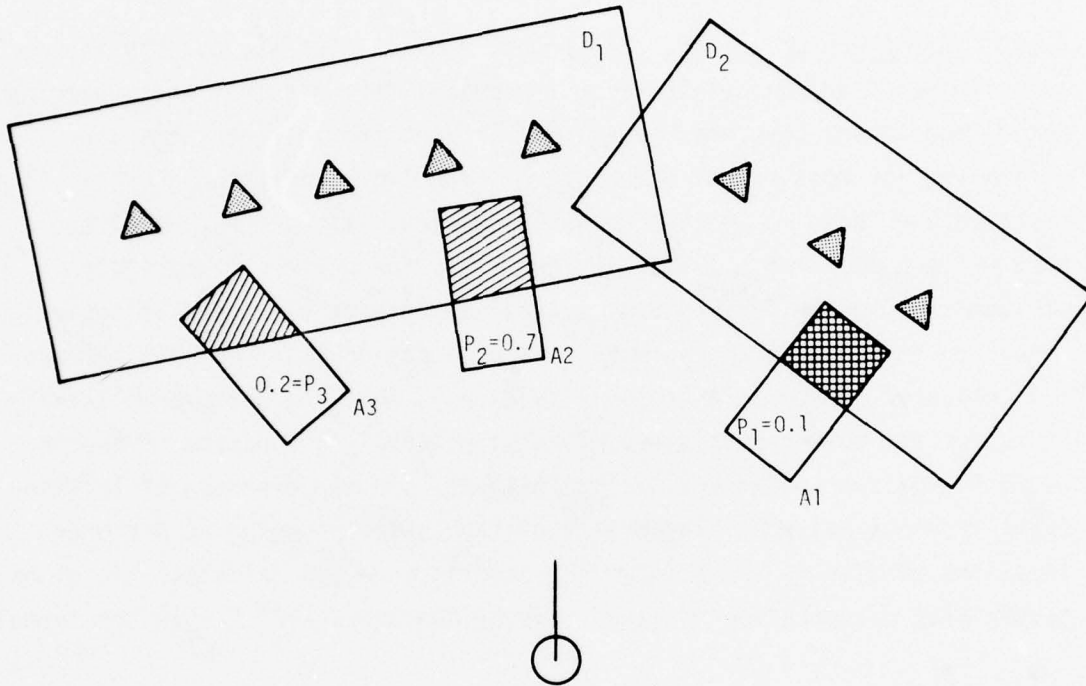

FIGURE 4-8. PROBABILITY DISTRIBUTION AND PATTERN COVERAGE

definitely detect a submarine. This corresponds to $B_i(x,y) = 0$ in these rectangles respectively. The probability of detection of the submarine by pattern #1 is proportional to the cross hatched parts of areas A1 and A2 while the probability of detection by pattern #2 proportional to the cross hatched part of area A3. In the more realistic model employed by the system the distributions will be more complex.

Model of Submarine Behavior. The submarine is modeled as moving in straight lines at a constant speed equal to that calculated from the last several fixes in the track. At the same time, there is a small, but nevertheless significant probability that the submarine will change course between t_0 and t_1 . This is taken into account by assigning a finite probability "weight" to other directions on the circle of radius $R = v(t_1 - t_0)$ centered on the current submarine location. Figure 4-9 shows a contour map of the total distribution. The significance of the contours is similar to the probability contour plot currently used on P-3C update system. For example, there is a probability of 0.7 that the submarine will be within the crosshatched area shown in the figure at time t_1 . Other contours are interpreted in similar manner. A constant probability is assumed over the area enclosed by a contour line.

The TACCO, with the help of the current P-3C update system, can simultaneously consider more than one track representing submarine location. This happens when several sequences of signals are detected which can be interpreted as a submarine motion. Thus, the TACCO cannot determine from the information available to him which is the true track and he must account for all possibilities in the calculations. In Figure 4-10 a situation with three live tracks is shown. (x_1, y_1) , (x_2, y_2) , and (x_3, y_3) are the current submarine locations as suggested by tracks 1, 2, and 3 respectively. The TACCO associates a level of confidence with each track which is converted (by normalizing to a sum = 1) to a probability associated with each track. These are the values $p_1 = 0.1$, $p_2 = 0.7$, and $p_3 = 0.2$ shown in Figure 4-10.

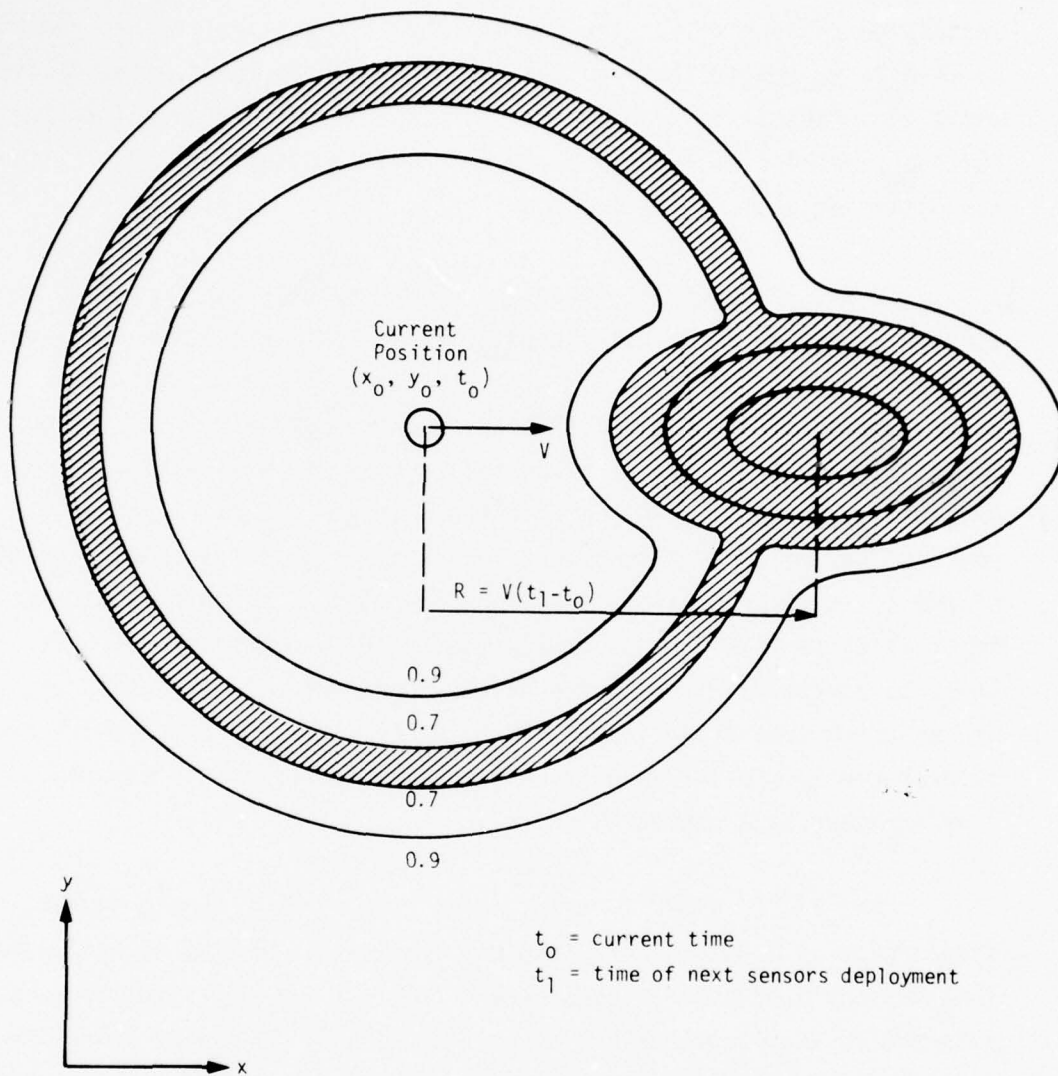

FIGURE 4-9. A PRIORI DISTRIBUTION OF SUBMARINE LOCATION AT TIME t_1

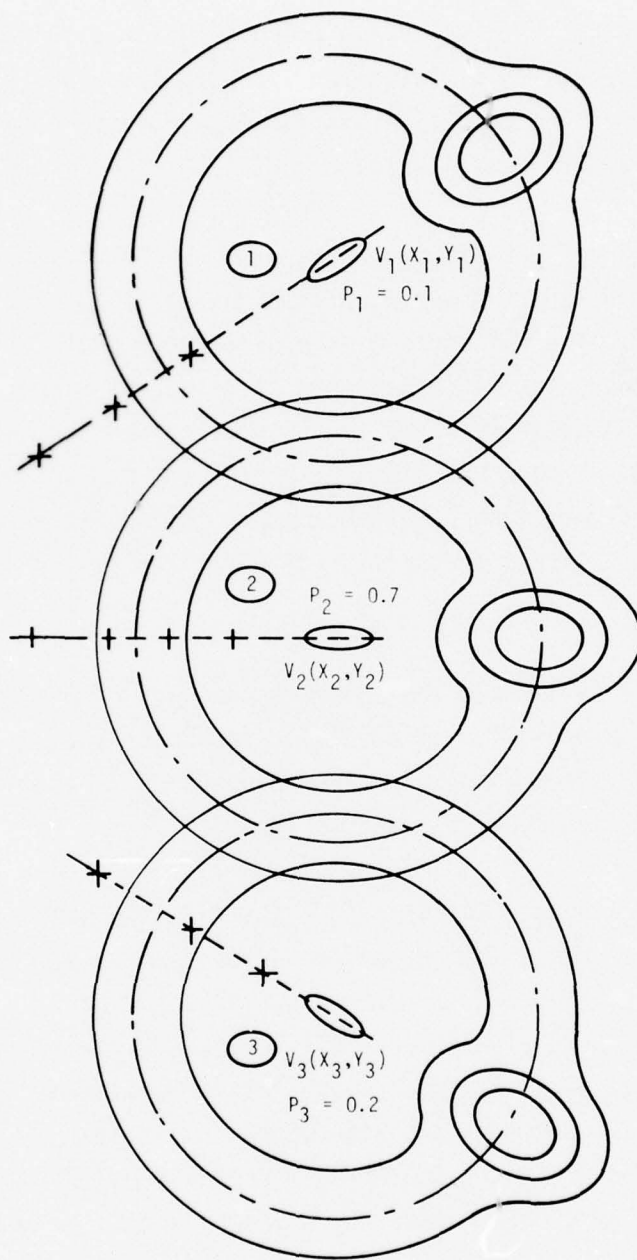

FIGURE 4-10. A COMPOSITE PROBABILITY DISTRIBUTION

Using these weights and the speed calculated for each track the computer can generate a probability distribution for each track and the sum of the three distributions is the composite distribution $P_S(x,y)$ used in the prediction of the probability of submarine detection.

Sensor Failure Distribution. The sensitivity area around each sonobuoy is modeled as a series of concentric disks of different thicknesses (Figure 4-11). The thickness of the disk represents the probability of detecting a submarine if it happened to be at the given distance from the sensor. The sensitivity zones of the several sensors which make up a pattern overlap in some areas, but since detecting the submarine by one sensor is independent of detection by other sensors in the pattern, the integrals calculating the global probability of detection can be calculated separately and the results added.

Figure 4-11 shows the coverage contours of a simple 3-buoy barrier pattern and the variation of detection probability as a function of the radial distance from a sensor. The values of R_1 , R_2 , and R_3 depend on the weather, submarine type, and sensor type, etc.

4.5.2 False Alarms. The sensors dropped in the water produce both positive and negative errors. The "negative" error $B(x,y)$ which is used in calculating the probability of submarine detection, is a failure to report a submarine present in the sensitive zone. This is usually small and is a result of total sensor failure, strong acoustic background noises in the water, or electromagnetic noises in the atmosphere. A "positive" error $\alpha(x,y)$ is a report by a sensor that a submarine is present where actually none exists. This error is more common than the β errors and is caused by the extreme sensitivity of the sensors which may mistake a large school of fish, a rock formation, or a surface disturbance in stormy weather for a submarine. Experience and pattern recognition skills of the SENSO reduce the level of these errors.

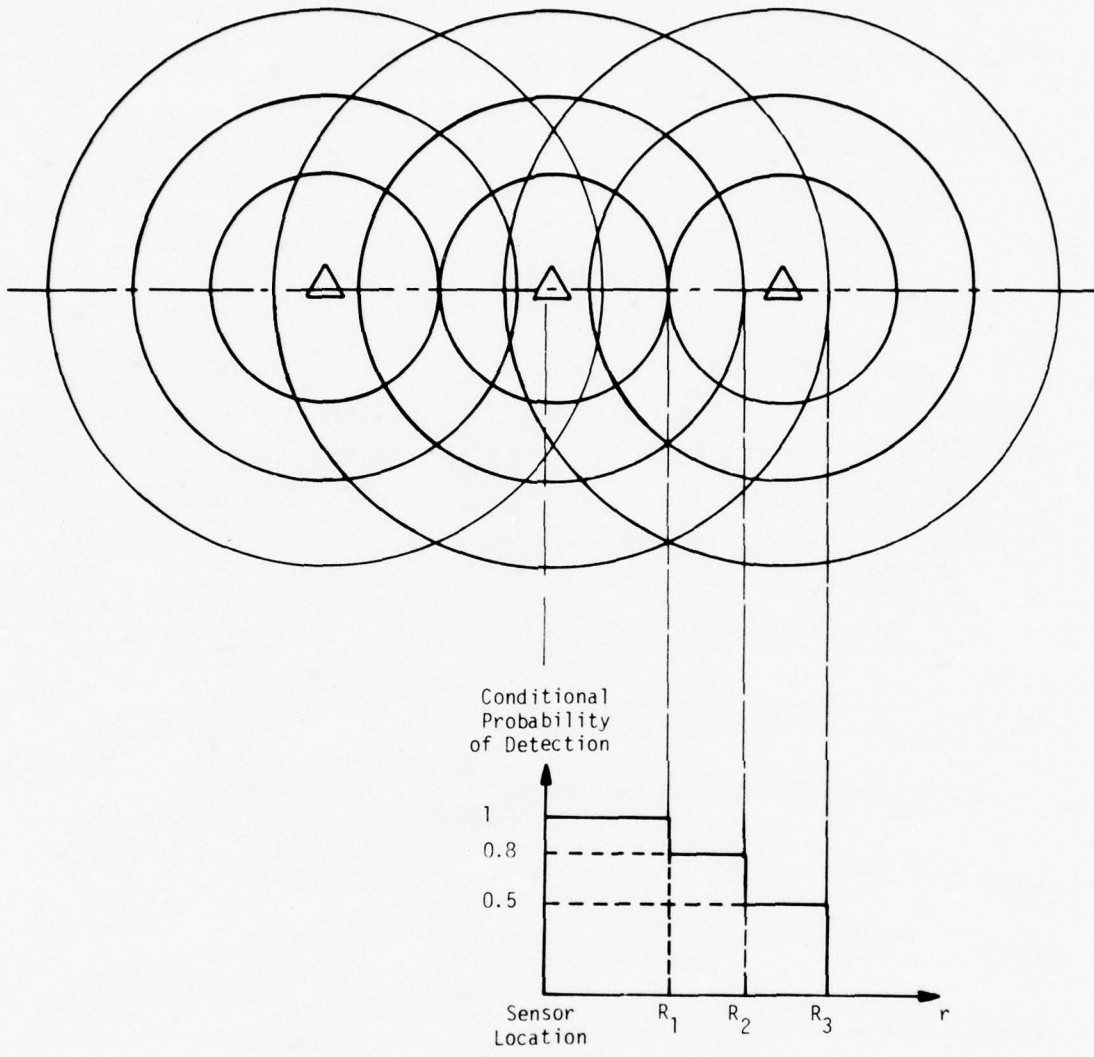

FIGURE 4-11. CONTOURS OF CONDITIONAL PROBABILITY OF SUBMARINE DETECTION AROUND A SENSOR PATTERN

The false alarm rate is given as a probability which is fixed for each pattern in a given drop but is a function of the following variables:

- (1) sensor types
- (2) number of sensors in the pattern
- (3) sea conditions
- (4) atmospheric condition

Each sensor type is associated with a probability P_{α} of positive errors. If there are N sensors in a given pattern, then the combined probability of error becomes nP_{α} . A fixed increase in the the probability of error is added when the sea condition is rough, P_{sc} , and similarly a fixed probability P_{ac} for bad atmospheric conditions. Altogether:

$$P_{\text{false alarm}} = n [P_{\alpha} + \delta_{sc} P_{sc} + \delta_{ac} P_{ac}]$$

where:

$$\delta_{sc} = \begin{cases} 0 & \text{when the sea is calm} \\ 1 & \text{when the sea is rough} \end{cases}$$

and
$$\delta_{ac} = \begin{cases} 0 & \text{when the atmosphere is quiet} \\ 1 & \text{when there is a storm} \end{cases}$$

The probability of false alarm is entered into the calculation of the expected utility for each pattern. The main difference between patterns in a given drop (all have the same sea and weather conditions) is the number of sensors.

4.5.3 Resource Depletion. The number of sensors still on board the P-3 Aircraft is an important consideration when deciding which pattern and with how many sensors to drop.

Through interviews with experience TACCO's, it is clear that ideally the sensors should be depleted in proportion to the length of time of the

mission so that the last sensors will be dropped into the water exactly when the mission is over. Thus, the sensors and fuel should end together. If the sensors are depleted before the fuel is exhausted, time is wasted which could have been used to track the submarine. Conversely, if the fuel is exhausted before all sensors have been used, the aircraft is forced to return to its base with less than optional utilization of sensors. Ignoring different types of sensors, if n_t is the number of sensors left on-board the aircraft at time t , then a plot of n_t versus t is the straight line shown in Figure 4-12. A parameter R_i which will indicate how good a given pattern i is in approaching the optimal rate of sensor depletion, is shown in Figure 4-13. The optimal number of sensors that should be on the plane at time t is:

$$N_{opt}(t) = N_0 \cdot \frac{T-t}{T}$$

where:

N_0 = the initial number of sensors on board

T = the total length of the mission in minutes

t = the time passed into the mission in minutes

Thus,

$$R_i = 1 - k \left| \frac{n_{ti} - n_{opt}(t)}{n_{opt}(t)} \right| = 1 - k \frac{T}{N_0(T-t)} \left| n_{ti} - N_0 \frac{(T-t)}{T} \right|$$

where:

n_{ti} the number of sensors left on the plane after dropping sensor pattern i

k a constant of proportionality which varies the acuteness of the parameter R_i .

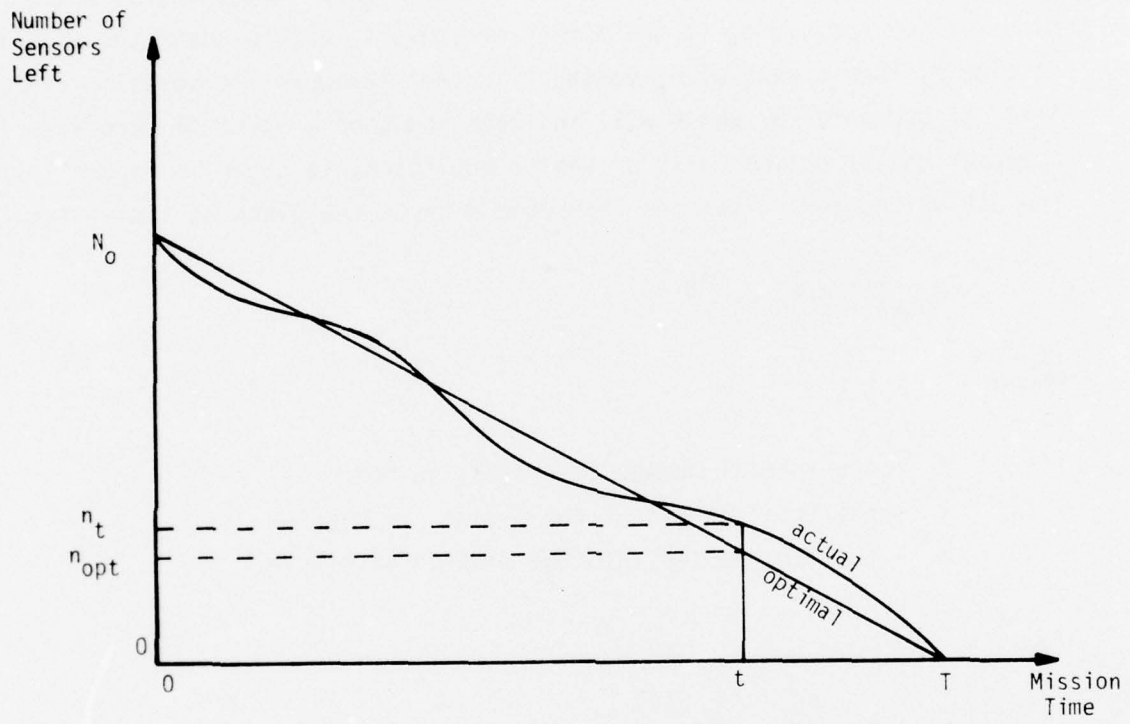
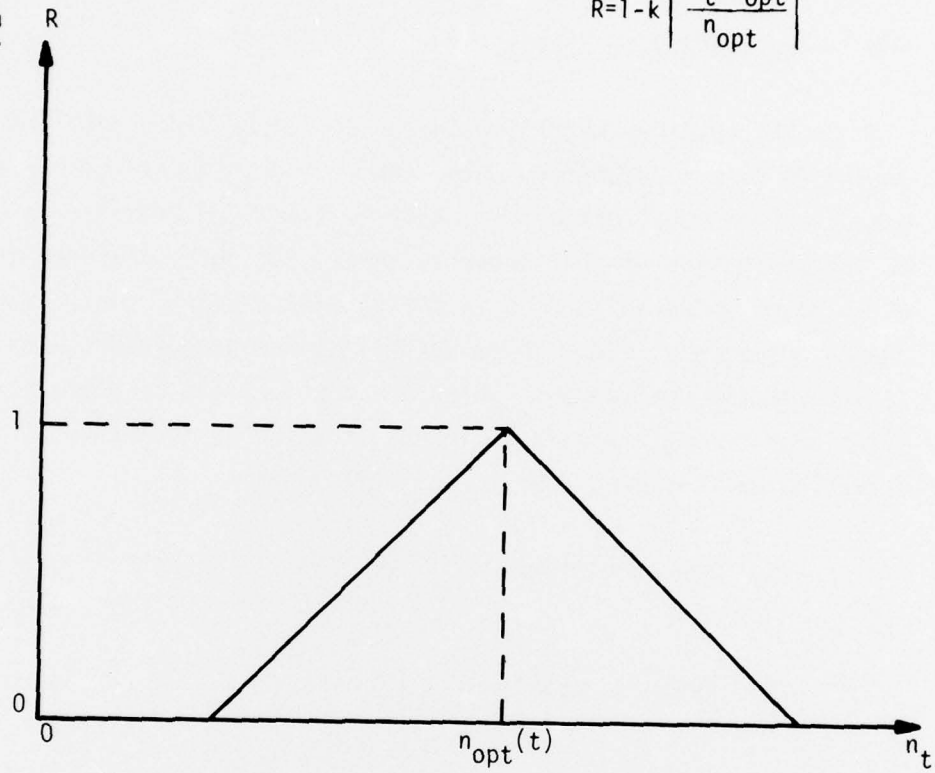

FIGURE 4-12. RESOURCE DEPLETION CHART

Resource
Depletion
Parameter



$$R = 1 - k \left| \frac{n_t - n_{opt}}{n_{opt}} \right|$$

FIGURE 4-13. RESOURCE DEPLETION PARAMETER VERSUS AVAILABLE SENSORS n_t

Figure 4-13 depicts the value of R_i as a function of n_{ti} . It is equal to 1 when the dropped pattern leaves $n_{ti} = n_{opt}(t)$ sensors on board and it is lower for both larger and lower n_{ti} . This parameter is used as one of the attributes in the multi-attribute model $R_i = R_{i4}$.

4.6 Environmental States

The adaptive model is linear, combining additively the contributions of the different parameters considered. The influence of variations in weather conditions, differing submarine type, and behavior is important in the evaluation of the sensor patterns, but this influence is not linear as it crops up as influences in the submarine model, sensor sensitivity range, error rate, etc. These variations are accounted for by defining "states of the environment" which are combinations of state variables. After questioning experienced TACCOs, the number and range of the state variables was narrowed down to the following:

- | | |
|--------------------------|------------|
| (1) Sea condition: | a. rough |
| | b. calm |
| (2) Weather condition: | a. stormy |
| | b. clear |
| (3) Submarine type: | a. diesel |
| | b. nuclear |
| (4) Submarine maneuvers: | a. enroute |
| | b. evasive |

Each combination of environmental variable values defines a different state of the environment and a different set of parameters is associated with them. The 4 state variables with 2 values each produces

16 possible "states of the world". These parameters are used in calculating the different probabilities in the model. Furthermore, a separate set of utilities is associated with each state of the environment and each such set must be trained separately. Although this requires a longer training period, convergence speed is gained on each set. When the state of the environment changes, the TACCO indicates such a change and the system switches to the appropriate set of parameters (pretrained) and can immediately proceed to predict the TACCO's decisions in the new situation. Without this provision, the system would have to go through a phase of retraining before it could predict correctly the TACCO's choices for each change in environmental conditions. Figure 4-14 depicts the different sets of parameters geometrically as "vectors" associated with the probabilities and utilities.

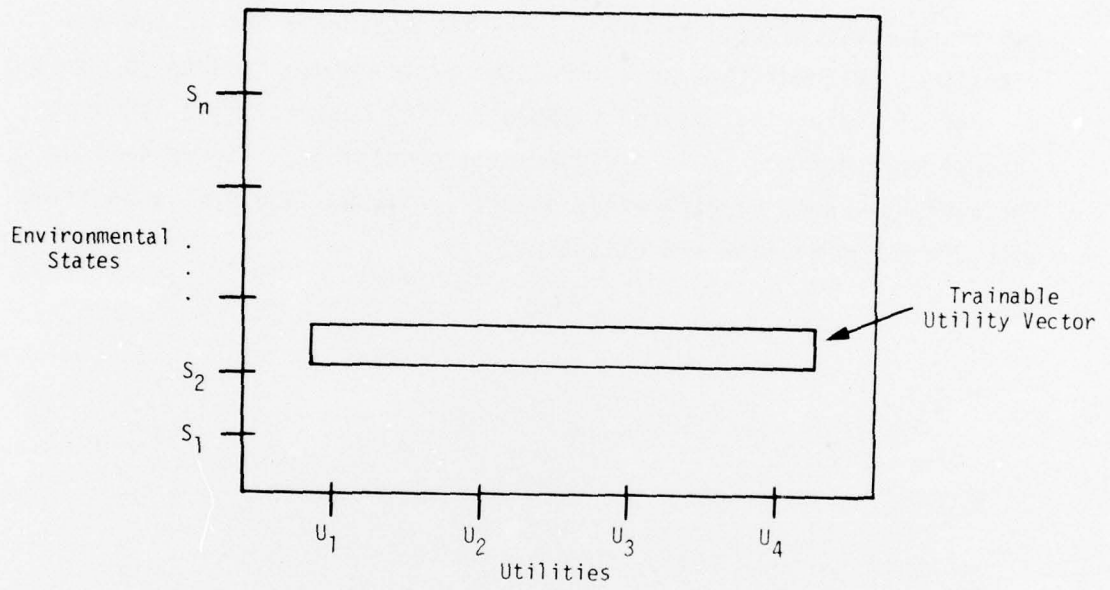

FIGURE 4-14. TWO DIMENSIONAL UTILITY SPACE

5. PRELIMINARY IMPLEMENTATION PLAN

5.1 System Concept

Figure 5-1 shows the system concept for the Integration of ADDAM into the current P-3 system. The vehicle for implementation and demonstration of the adaptive decision aiding algorithms is the Laboratory Functional Prototype System (LFPS), a core subset of the total P-3 system capable of stand-alone operation.

The LFPS program contains the necessary functions for complete demonstration of the ADDAM concept with the exception of the module for optimal sensor placement. This module is in the form of a coded (but not running) mathematical routine called AZOI developed at NADC. It will be incorporated into the LFPS environment for use by ADDAM.

5.2 System Specifications

The ADDAM system will be compiled under the programming language CS-1 independently as a system procedure and will be debugged on the UNIVAC CP-642B computer in Los Angeles, California. After it has been debugged, the ADDAM system then will be retrieved for inclusion within the ASW Tactics and Tracking system routine on the NADC CP-901 computer at the time of final compilation. These tasks can be illustrated in the following diagram:

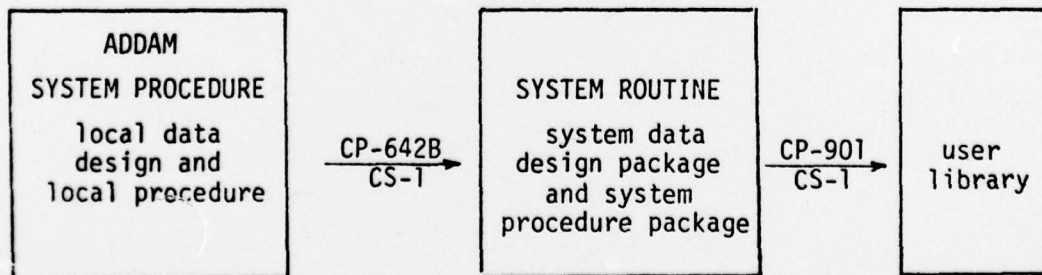

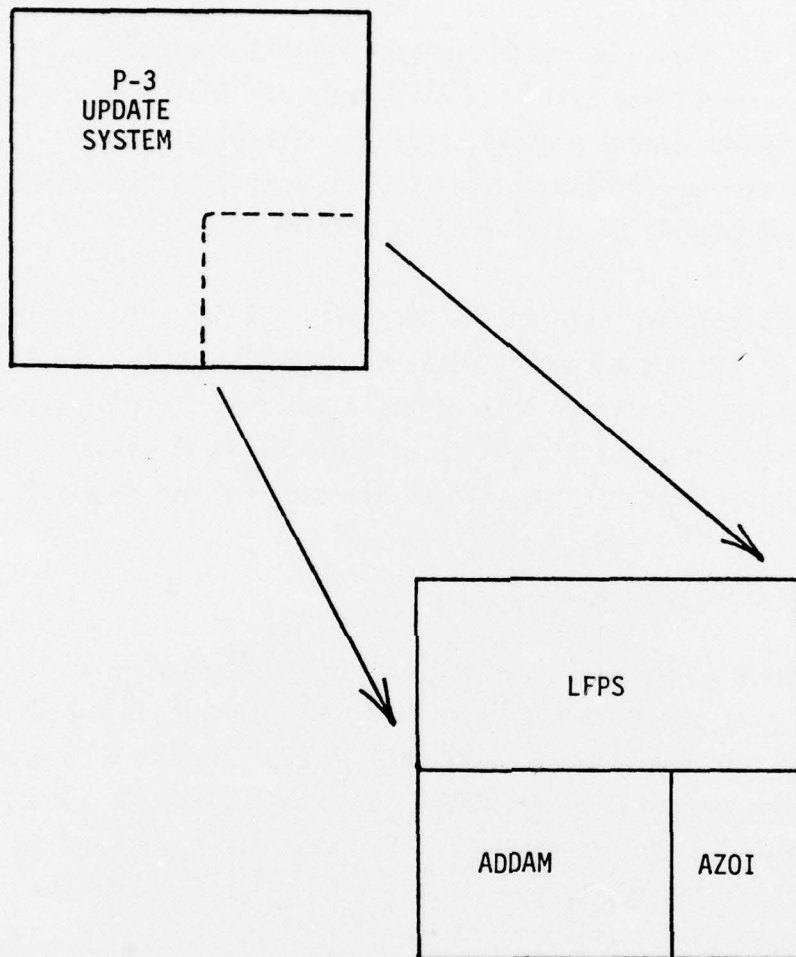

FIGURE 5-1. SYSTEM CONCEPT

During debugging, the total execution time can be controlled by changing the software structure and by modifying the system algorithm. The reason for precise time tracing is that the time constraint in the existing NADC ASW program is critical for continuous display update cycles.

The CP-642B and CP-901 computers have the same repertoire of operations and the same functional performance except that CP-901 has the paging and re-entrant capabilities. To achieve the above two capabilities, eight instructions have been added to CP-901. Since the existing ASW environment is neither a multi-programming nor a time-sharing system, none of the additional eight instructions will be used in the ADDAM system. As far as the instruction execution time and memory cycle time are concerned, the CP-901 would not be any slower than CP-642B. The CP-642B computer system, which will be used by ADDAM, is located at the UNIVAC Computer Operations in Valencia, California. Either a stand-alone operation or batch operating system can be utilized upon request.

6. REFERENCES

Beach, B.H. Expert Judgment About Uncertainty: Bayesian Decision Making in Realistic Settings. Organizational Behavior and Human Performance, 1975, 14:10-59.

Edwards, W. Dynamic Decision Theory and Probabilistic Information Processing. Human Factors, 1962, 4:59-74.

Fishburn, P.C. Methods of Estimating Additive Utilities. Management Science, March 1967, 13(7):435-453.

Freedy, A., Davis, K.B., Steeb, R., Samet, M.G., and Gardiner, P.C. Adaptive Computer Aiding in Dynamic Decision Processes: Methodology, Evaluation, and Application. Perceptrics, Inc. (Woodland Hills, CA) Final Technical Report PFTR-1016-76-8/30, Contract N00014-73-C-0286/NR196-128, ARPA Order No. 2347, Code 455, Office of Naval Research, August 1976.

Freedy, A., Weisbrod, R., and Weltman, G. Self-Optimization of Task Allocation in Shared Man/Computer Control. Proc. of the IEEE Conference on Decision and Control, Paper No. FP5-3, San Diego, California, December 5-7, 1973.

Johnson, E.M., and Halpin, S.M. Preliminary Evaluation of a Multi-Stage Bayesian Inference System. The Proceedings of International Conference on Cybernetics and Society, IEEE SMC Society, October 1972.

Kneppreth, N.P., Gustafson, D.H., Leifer, R.P., and Johnson, E.M. Techniques for Assessment of Worth. U.S. Army Research Institute for the Behavioral and Social Sciences (Arlington, VA) Technical Paper 254, August 1974.

Krantz, D.M., Luce, R.D., Suppes, P., and Tversky, A. Foundations of Measurement: Additive and Polynomial Representations, I. New York: Academic Press, 1971.

Rapoport, A., and Wallsten, T.S. Individual Decision Making. Annual Review of Psychology, 1972, 23:131-176.

Samet, M.G., Weltman, G., and Davis, K.B. Application of Adaptive Models to Information Selection in C3 Systems. Perceptrics (Woodland Hills, CA) Technical Report PTR-1033-76-12, Contract MDA903-76-C-0241, Defense Advanced Research Project Agency, December 1976.

Slagle, J.R. Artificial Intelligence: The Heuristic Programming Approach. New York: McGraw Hill, 1971.

DISTRIBUTION LIST

Director, Engineering Psychology
Programs, Code 455
Office of Naval Research
800 North Quincy Street
Arlington, VA 22217 (5 cys)

Defense Documentation Center
Cameron Station
Alexandria, VA 22314 (12 cys)

Dr. Robert Young, Director
Cybernetics Technology Office
Advanced Research Projects Agency
1400 Wilson Blvd.
Arlington, VA 22209

Lt. Col. Henry L. Taylor, USAD
OAD(E&LS) ODDR&E
Pentagon, Room 3D129
Washington, D.C. 20301

Capt. Roger Granum
Office of Assistant Secretary
of Defense (Intelligence)
Pentagon, Room 3C200
Washington, D.C. 20301

Office of Naval Research
International Programs
Code 102IP
800 North Quincy Street
Arlington, VA 22217 (6 cys)

Director, Avionics & Weapons
Programs, Code 212
Office of Naval Research
800 North Quincy Street
Arlington, VA 22217

Director, Sensor Technology
Program, Code 222
Office of Naval Research
800 North Quincy Street
Arlington, VA 22217

Director, Fleet Analysis and Support
Division, Code 230
Office of Naval Research
800 North Quincy Street
Arlington, VA 22217

Director, Naval Analysis Programs
Code 31
Office of Naval Research
800 North Quincy Street
Arlington, VA 22217

Director, Operations Research
Programs, Code 434
Office of Naval Research
800 North Quincy Street
Arlington, VA 22217

Director, Statistics and
Probability Program, Code 436
Office of Naval Research
800 North Quincy Street
Arlington, VA 22217

Director, Information Systems
Program, Code 437
Office of Naval Research
800 North Quincy Street
Arlington, VA 22217

Commanding Officer
ONR Branch Office
ATTN: Dr. J. Lester
495 Summer Street
Boston, MA 02210

Commanding Officer
ONR Branch Office
ATTN: Dr. Charles Davis
536 South Clark Street
Chicago, IL 60605

Commanding Officer
ONR Branch Office
ATTN: Dr. E. Gloye
1030 East Green Street
Pasadena, CA 91106

Commanding Officer
ONR Branch Office
ATTN: Mr. R. Lawson
1030 East Green Street
Pasadena, CA 91106

Dr. M. Bertin
Office of Naval Research
Scientific Liaison Group
American Embassy, Room A-407
APO San Francisco 96503

Director, Naval Research Laboratory
Technical Information Division
Code 2627
Washington, D.C. 20375 (6 cys)

Mr. John Hill
Naval Research Laboratory
Code 5707.40
Washington, D.C. 20375

Office of the Chief of Naval
Operations, OP987P10
Personnel Logistics Plans
Department of the Navy
Washington, D.C. 20350

Dr. Andreas B. Rechnitzer
Office of the Oceanographer
of the Navy
Hoffman Building II
200 Stoval Street
Alexandria, VA 22332

Mr. Arnold Rubinstein
Naval Material Command
NACMAR 0344
Department of the Navy
Washington, D.C. 20360

Commander
Naval Air Systems Command
Human Factors Programs, AIR 340F
Washington, D.C. 20361

Mr. T. Momiya
Naval Air Systems Command
Advance Concepts Division, AIR 03P34
Washington, D.C. 20361

Commander
Naval Electronics Systems Command
Human Factors Engineering Branch
Code 4701
Washington, D.C. 20360

LCDR T.W. Schropp
Naval Sea Systems Command
NAVSEA 00C3
Washington, D.C. 20362

Dr. James Curtin
Naval Sea Systems Command
Personnel & Training Analyses Office
NAVSEA 074C1
Washington, D.C. 20362

Mr. James Jenkins
Naval Sea Systems Command
Code 06H1-3
Washington, D.C. 20362

CDR Paul Nelson
Naval Medical R&D Command
Code 44
Naval Medical Center
Bethesda, MD 20014

Director
Behavioral Sciences Department
Naval Medical Research Institute
Bethesda, MD 20014

Dr. George Moeller
Human Factors Engineering Branch
Submarine Medical Research Laboratory
Naval Submarine Base
Groton, CT 06340

Chief, Aerospace Psychology Division
Naval Aerospace Medical Institute
Pensacola, FL 32512

Bureau of Naval Personnel
Special Assistant for Research
Liaison
PERS-OR
Washington, D.C. 20370

Navy Personnel Research and
Development Center
Management Support Department
Code 210
San Diego, CA 92152

Dr. Fred Muckler
Navy Personnel Research and
Development Center
Manned Systems Design, Code 311
San Diego, CA 92152

LCDR P.M. Curran
Human Factors Engineering Branch
Crew Systems Department
Naval Air Development Center
Warminster, PA 18974

LCDR William Moroney
Human Factors Engineering Branch
Code 1226
Pacific Missile Test Center
Point Mugu, CA 93042

Human Factors Section
Systems Engineering Test Directorate
U.S. Naval Air Test Center
Patuxent River, MD 20670

Human Factors Division
Naval Ocean Systems Center
San Diego, CA 92152

Human Factors Engineering Branch
Naval Ship Research and Development
Center, Annapolis Division
Annapolis, MD 21402

Commanding Officer
Naval Coastal Systems Laboratory
Panama City, FL 32401

Dr. Robert French
Naval Ocean Systems Center
San Diego, CA 92132

Dr. Jerry C. Lamb
Display Branch
Code TD112
Naval Underwater Systems Center
New London, CT 06320

Naval Training Equipment Center
ATTN: Technical Library
Orlando, FL 32813

Human Factors Department
Code N215
Naval Training Equipment Center
Orlando, FL 32813

Dr. Alfred F. Smode
Training Analysis and Evaluation Group
Naval Training Equipment Center
Code N-00T
Orlando, FL 32813

Dr. Gary Poock
Operations Research Department
Naval Postgraduate School
Monterey, CA 93940

Dr. A. L. Slafkosky
Scientific Advisor
Commandant of the Marine Corps
Code RD-1
Washington, D.C. 20380

Mr. J. Barber
Headquarters, Department of the
Army, DAPE-PBR
Washington, D.C. 20546

Dr. Joseph Zeidner
Director, Organization and Systems
Research Laboratory
U.S. Army Research Institute
1300 Wilson Boulevard
Arlington, VA 22209

Dr. Edgar M. Johnson
Organization and Systems
Research Laboratory
U.S. Army Research Lab
1300 Wilson Blvd.
Arlington, VA 22209

Technical Director
U.S. Army Human Engineering Labs
Aberdeen Proving Ground
Aberdeen, MD 21005

ARI Field Unit - Leavenworth
Post Office Box 3122
Fort Leavenworth, Kansas 66027

U.S. Army Aeromedical Research Lab
ATTN: CPT Gerald P. Krueger
Ft. Rucker, Alabama 36362

U.S. Air Force Office of Scientific
Research
Life Sciences Directorate, NL
Bolling Air Force Base
Washington, D.C. 20332

Dr. Donald A. Topmiller
Chief, Systems Engineering Branch
Human Engineering Division
USAF AMRL/HES
Wright-Patterson AFB, OH 45433

Lt. Col. Joseph A. Birt
Human Engineering Division
Aerospace Medical Research Laboratory
Wright Patterson AFB, OH 45433

Air University Library
Maxwell Air Force Base, AL 36112

Dr. Robert Williges
Human Factors Laboratory
Virginia Polytechnic Institute
130 Whittemore Hall
Blacksburg, VA 24061

Mr. Alan J. Pesch
Eclectech Associates, Inc.
Post Office Box 179
North Stonington, CT 06359

Dr. W. S. Vaughan
Oceanautics, Inc.
3308 Dodge Park Road
Landover, MD 20785

Dr. Arthur I. Siegel
Applied Psychological Services, Inc.
404 East Lancaster Street
Wayne, PA 19087

Dr. Robert R. Mackie
Human Factors Research, Inc.
Santa Barbara Research Park
6780 Cortona Drive
Goleta, CA 93017

Dr. H. Rudy Ramsey
Science Applications, Inc.
40 Denver Technological Center West
7935 East Prentice Avenue
Englewood, Colorado 90110

Dr. Paul Slovic
Decision Research
1201 Oak Street
Eugene, OR 97401

Professor Douglas E. Hunter
Defense Intelligence School
Washington, D.C. 20374

Dr. Rex Brown
Decisions & Designs, Inc.
8400 Westpark Drive, Suite 600
McLean, VA 22101

Mr. E. M. Connelly
Omnemii, Inc.
410 Pine Street, S.E., Suite 200
Vienna, VA 22180

Dr. Clinton Kelly
Decisions & Designs, Inc.
8400 Westpark Drive, Suite 600
McLean, VA 22101

Dr. Terence R. Mitchell
University of Washington
Seattle, WA 98195

Dr. Jesse Orlansky
Institute for Defense Analyses
400 Army-Navy Drive
Arlington, VA 22202

Dr. Stanley Deutsch
Office of Life Sciences
HQs, NASA
600 Independence Avenue
Washington, D.C. 20546

Director, National Security Agency
ATTN: Dr. Douglas Cope
Code R51
Ft. George G. Meade, MD 20755

Journal Supplement Abstract Service
American Psychological Association
1200 17th Street, NW
Washington, D.C. 20036 (3 cys)

Dr. William A. McClelland
Human Resources Research Office
300 N. Washington Street
Alexandria, VA 22314

Navy C3 Architecture Division,
OP-943
Office of the Chief of Naval
Operations
ATTN: LCDR D. A. Spaugy
3801 Nebraska Ave., N.W.
Washington, D.C. 20390

Commander, Naval Electronics
Systems Command
Command and Control Division
Code 530
Washington, D.C. 20360

Mr. L. A. Aarons
R&D Plans Division
Office of the Chief of Naval
Operations
OP-987C
Washington, D.C. 20350

Commander, Naval Electronics
Systems Command
C3 Project Office
PME 190-1
ATTN: LCDR E. Neely
Washington, D.C. 20360

LCDR Charles Theisen
Naval Air Development Center
Code 4024
Warminster, PA 18974

Dr. S. D. Epstein
Analytics
2500 Maryland Road
Willow Grove, PA 19090

Mr. Harold Crane
CTEC, Inc.
7777 Leesburg Pike
Falls Church, VA 22043

Dr. Robert Andrews
Organizations & Systems Research
Laboratory
U.S. Army Research Lab
1300 Wilson Boulevard
Arlington, VA 22209

Mr. George Pugh
General Research Corporation
7655 Old Springhouse Road
McLean, Virginia 22101

Mr. Gary W. Irving
Integrated Sciences Corporation
1532 Third Street
Santa Monica, CA 90401

Dr. Miley Merkhofer
Stanford Research Institute
Decision Analysis Group
Menlo Park, CA 94025

Mr. Victor Rowney
Stanford Research Institute
Naval Warfare Research Center
Menlo Park, CA 94025

Dr. H. L. Morgan
University of Pennsylvania
Wharton School
Philadelphia, PA 19174

Lt. Brenneman
COMOPTVFOR
Norfolk, VA 23511

M. L. Metersky
NAVAIRDEVCON, Code 5424
Warminster, PA 18974

Lt. Col. David Dianich
HQS Tactical Air Command
Langley AFB, VA 22065

Mr. Victor Monteleon
Naval Electronics Laboratory
Center, Code 230
San Diego, CA 92152

CDR Richard Schlaff
NIPSSA
Hoffman Bldg. #1
2461 Eisenhower Avenue
Alexandria, VA 22331

Commander, Naval Electronics
Systems Command
ELEX-03
Washington, D.C. 20360

Dr. Chantee Lewis
Management Department
Naval War College
Newport, R.I. 02840

Dr. John Shore
Code 5403
Communications Sciences Division
Naval Research Laboratory
Washington, D.C. 20375