

AD-A040 226

SIPPICAN CORP MARION MASS OCEANOGRAPHIC SYSTEMS DIV F/G 17/1  
FEASIBILITY STUDY: AXBT/EA AIRBORNE EXPENDABLE BATHYTHERMOGRAPH--ETC(U)  
MAY 77 C B TIRRELL, R G WASHBURN, M J BALBONI N00014-76-C-0230

UNCLASSIFIED

R-817

NL

1 OF 2  
AD  
A040226



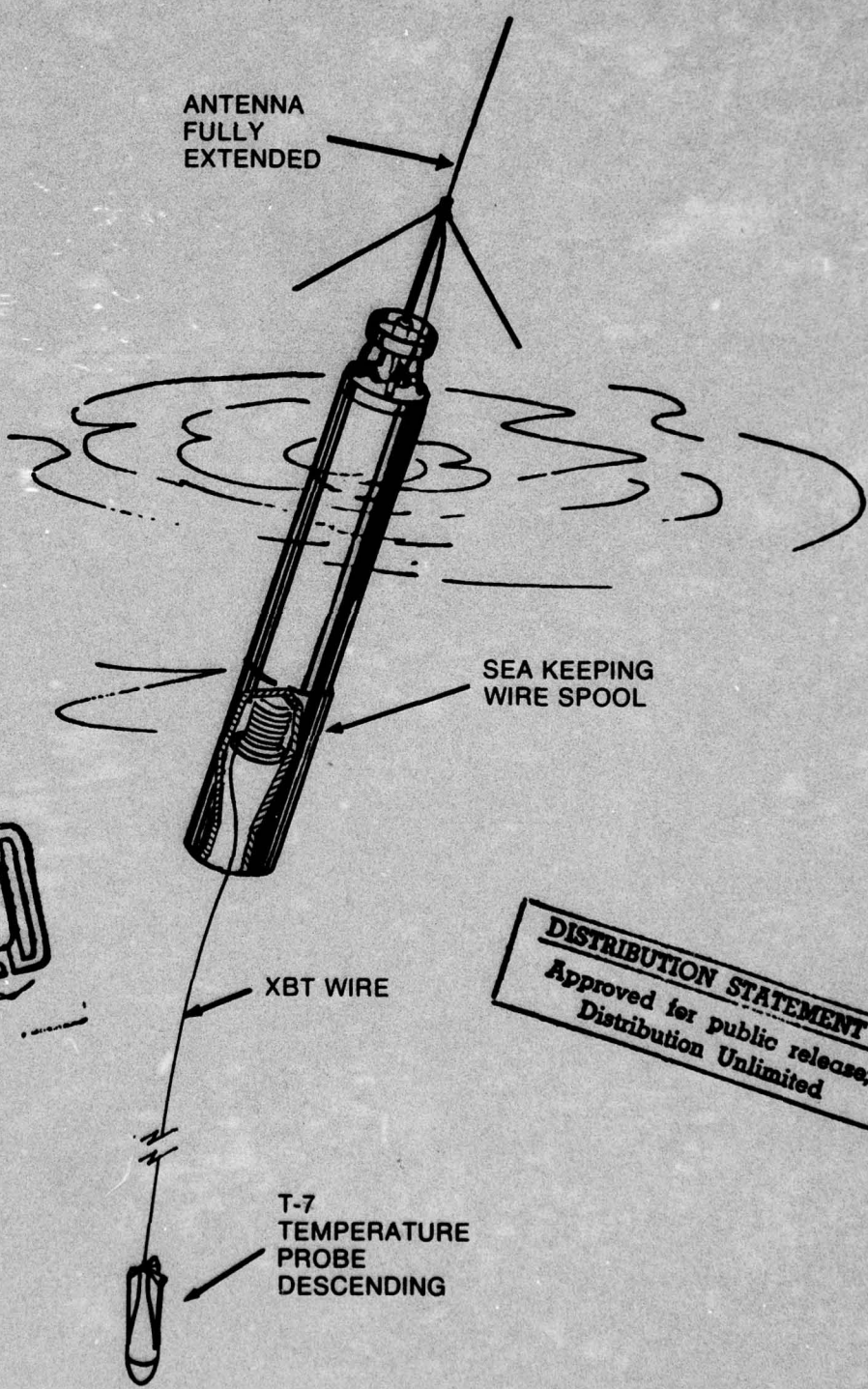
**AXBT PROBE/ELECTRONICS**

**FINAL REPORT  
FEASIBILITY STUDY  
AN/SSQ-36 PIP**

**PREPARED FOR  
OFFICE OF NAVAL RESEARCH  
17 MAY 1977  
UNDER CONTRACT  
N00014-76-C-0230**

ADA 040 226

13



DDC  
 JUN 6 1977  
 C

**DISTRIBUTION STATEMENT A**  
 Approved for public release;  
 Distribution Unlimited

AD No. \_\_\_\_\_  
 DDC FILE COPY

**SIPPICAN CORPORATION**  
 MARION, MASSACHUSETTS 02738

UNCLASSIFIED

SECURITY CLASSIFICATION OF THIS PAGE (When Data Entered)

REPORT DOCUMENTATION PAGE

READ INSTRUCTIONS  
BEFORE COMPLETING FORM

1. REPORT NUMBER	2. GOVT ACCESSION NO.	3. RECIPIENT'S CATALOG NUMBER
	(9)	
4. TITLE (and Subtitle) FEASIBILITY STUDY: AXBT/EA AIRBORNE EXPENDABLE BATHYTHERMOGRAPH/ ELECTRONICS ASSEMBLY		5. TYPE OF REPORT & PERIOD COVERED FINAL <del>REPORT</del> <sup>REPORT</sup>
AUTHOR(s) C. N. Tirrell, G. Washburn, J. Balboni, P. Demeo		6. PERFORMING ORG. REPORT NUMBER R-817
PERFORMING ORGANIZATION NAME AND ADDRESS Ocean Systems Division The Sippican Corporation Marion, MA 02738		7. CONTRACT OR GRANT NUMBER(s) N00014-76-C-0230
11. CONTROLLING OFFICE NAME AND ADDRESS Ocean Science and Technology Division Office of Naval Research 800 N. Quincy St., Arlington, VA 22207		10. PROGRAM ELEMENT, PROJECT, TASK AREA & WORK UNIT NUMBERS
14. MONITORING AGENCY NAME & ADDRESS (if different from Controlling Office)		12. REPORT DATE 17 May 77
		13. NUMBER OF PAGES 132 145 p.
		15. SECURITY CLASS. (of this report) Unclassified
		15a. DECLASSIFICATION/DOWNGRADING SCHEDULE

16. DISTRIBUTION STATEMENT (of this Report)  
Approved for public release; distribution unlimited.

17. DISTRIBUTION STATEMENT (of the abstract entered in Block 20, if different from Report)

18. SUPPLEMENTARY NOTES

19. KEY WORDS (Continue on reverse side if necessary and identify by block number)  
Sonobuoy  
Expendable Bathythermograph  
ASW

20. ABSTRACT (Continue on reverse side if necessary and identify by block number)  
The Sippican Corporation conducted a study for the Office of Naval Research to prove the feasibility of incorporating a Model T-7 XBT and a self-calibrating interface circuit into the AN/SSQ-36 Sonobuoy. This would improve the accuracies of the buoy to those of the XBT system ( $\pm 0.2^\circ\text{C}$ ,  $\pm 2\%$  of depth) and increase depth capability to 760 meters. Further investigation was then made into the costs associated with this improvement. This report details the results of these investigations.

6  
Barry  
10  
Michael  
Robert

Ralph

409947

409947

Handwritten signature

Prepared Under  
CONTRACT N00014-76-C-0230

R-817  
Final Report  
Feasibility Study  
AXBT/EA  
"Airborne Expendable Bathy-  
thermograph/Electronics Assembly"

By

C. Barry Tirrell  
Ralph G. Washburn  
Michael J. Balboni  
Robert P. Demeo

The Sippican Corporation  
Marion, Massachusetts

ADDITIONAL TO:	White Section	<input checked="" type="checkbox"/>
NTIS	Ref Section	<input type="checkbox"/>
DIC		<input type="checkbox"/>
UNANNOUNCED JUSTIFICATION		
BY	DISTRIBUTION/AVAILABILITY CODES	
	Dist.	AVAIL. and/or SPECIAL
A		

ABSTRACT

Sippican Report, R-798, "Interim Report - Feasibility Study AXBT/EA" (see Appendix), detailed the results of a study Sippican conducted for the Office of Naval Research which proved the feasibility of incorporating a model T-7 XBT and a self-calibrating interface circuit into the AN/SSQ-36 Sonobuoy. This modification would improve the accuracies of the buoy ( $\pm 0.55^{\circ}\text{C}$ ,  $\pm 5\%$  of depth) to those of the XBT System ( $\pm 0.2^{\circ}\text{C}$ ,  $\pm 2\%$  of depth) and would also increase the AXBT depth capability from 305 meters to 760 meters.

This report investigates the production circuit configuration alternatives, the applicable tooling costs and the expected final production cost for a T-7 XBT subassembly which could be incorporated into an AXBT. A custom integrated circuit on a printed wiring board is chosen as the final circuit configuration. A computer analysis of the circuit is conducted to determine which bridge resistor can be integrated and what tolerances are required. Final unit production cost of the AXBT/EA are shown to be \$32.88 in quantities of 20,000.

## TABLE OF CONTENTS

<u>Section</u>		<u>Page</u>
	ABSTRACT	i
	SUMMARY OF FINDINGS & RECOMMENDATIONS	iv
1.0	INTRODUCTION	1-1
2.0	DESIGN REQUIREMENTS	2-1
	2.1 Power Requirements	2-1
	2.2 Mode Sequencing	2-1
	2.3 Electrical Interface	2-2
	2.4 Mechanical Interface	2-2
3.0	HYBRID CIRCUIT	3-1
	3.1 Technique	3-1
	3.2 Results	3-1
4.0	CUSTOM INTEGRATED CIRCUIT ON A PRINTED WIRING BOARD	4-1
	4.1 Technique	4-1
	4.2 Approach	4-1
	4.3 Limitations	4-2
	4.4 Results	4-2
5.0	COMPUTER ANALYSIS	5-1
	5.1 Approach	5-1
	5.2 Technique	5-1
	5.3 Results (Reference Sippican Drawing D213827)	5-2
	5.4 Sum of the Errors	5-3
6.0	PACKAGING DESIGN	6-1
	6.1 Purpose	6-1
	6.2 Description	6-1
	6.3 Summary of Launch Sequence	6-3

## TABLE OF CONTENTS (Continued)

<u>Section</u>		<u>Page</u>
7.0	T-7 PROBE RELIABILITY	7-1
8.0	PRODUCTION QUANTITY PRICING	8-1
	8.1 Unit Costs	8-1
	8.2 Tooling Costs	8-1
9.0	CONCLUSIONS	9-1
10.0	RECOMMENDATIONS	10-1

APPENDIX: Sippican Report - R-798, (Interim Report - Feasibility Study "AXBT/EA" Airborne Expendable Bathythermograph Electronics Assembly)

**SUMMARY OF FINDINGS AND RECOMMENDATIONS:**

- a. Sippican's 760m T-7 XBT can be incorporated into the AN-SSQ-36 buoy with resultant increased depth and temperature accuracies and increased depth capability. This modification of the AN/SSQ-36 has the additional benefit of permitting the use of an updated buoy for higher altitude/colder temperature launch.
- b. The electrical interface of the T-7 XBT to the AN/SSQ-36 can be most economically accomplished using the inventive self-calibrating circuit described herein. This circuit ensures accuracy of the system while minimizing the required number of expensive, high-quality components.
- c. The self-calibrating AXBT circuit can be most economically produced as a custom integrated circuit on a printed wiring board. A functional breadboard of this circuit has been built and satisfactorily tested.
- d. Computer analysis of the self-calibrating AXBT circuit revealed that three-sigma root-sum-squared errors of less than 0.15 degrees Celsius were achievable using low cost components.
- e. A preliminary drawing set of the AXBT/EA packaging design has been generated and production costs established.
- f. T-7 Probe reliability demonstration and product acceptance test plans have been formulated. It is probable that a reliability of .98 is achievable.

SUMMARY OF FINDINGS AND RECOMMENDATIONS: (Continued)

- g. Production quantity tooling costs, with the exception of the tooling cost for the custom integrated circuit which will be borne by Sippican, are estimated at \$79,853.13.
- h. Total AXBT/EA costs in production quantities of 20,000 units are estimated at \$32.88 per probe.
- i. It is recommended that 1,000 AN/SSQ-36 PIP AXBT's be manufactured for performance and reliability demonstration.

Final Report  
Feasibility Study  
AXBT/EA

1.0 INTRODUCTION

1.1 General

Since 1963, Sippican has developed and produced expendable Bathythermographs (XBT's), recording, launching and measuring systems for use by the U. S. Navy and oceanographic communities for economical and accurate temperature versus depth measurements. The Surface Ship Expendable Bathythermograph (SXBT) and its shipboard launching equipment has been used worldwide. Over 2,000,000 SXBT's and over 1,000 shipboard recording and measuring systems have been manufactured and sold. SXBT's are supplied in six different models with depth capabilities ranging to 6,000 feet. Currently the Model T-7 XBT is the unit in largest demand and usage.

The engineering expertise acquired in the development of the XBT and its associated measuring circuits has made it possible for Sippican to pursue the development of other related military and oceanographic equipment. Recently under contract to Johns Hopkins University's Applied Physics Lab, Sippican designed a state-of-the-art high resolution, high

accuracy (0.001°C resolution,  $\pm 0.01^\circ\text{C}$  accuracy) towed thermistor chain which has been used successfully in the Caribbean. Also, under contract to NAVSEASYSKOM, Sippican has designed the Submarine Launched XBT (SSXBT) and a newer more sophisticated recorder for use with the SSXBT.

Sippican is presently under contract to the U. S. Navy to deliver approximately 17,000 SSXBT's for submarine use. The temperature probe portion of the SSXBT is the Sippican Model T-7, and its accuracy is the same as the SXBT. The T-7 as used in the SSXBT is by its nature very similar to a T-7 used in an improved AXBT. That is, both devices require the release of a T-7 from a surface-floating buoy.

## 1.2 AXBT/EA

In August 1975, at the request of ONR, the Sippican Corporation submitted a proposal to investigate the feasibility of improving the accuracies and depth capability of the AN/SSQ-36 AXBT Sonobuoy ( $\pm 0.55^\circ\text{C}$ ,  $\pm 5\%$  of depth, 305m) to the accuracies and depth capability of the Sippican Expendable Bathythermograph System using T-7 probes ( $\pm 0.2^\circ\text{C}$ ,  $\pm 2\%$  of depth, 760m). Sippican report R-798, included in the Appendix, is an interim report which proved the feasibility of in-

corporating the T-7 and a self-calibrating interface circuit into the AN/SSQ-36. The results of that report are briefly summarized in the next few paragraphs. This report then investigates further, the production circuit configuration alternatives, the applicable tooling costs, the expected final production costs and the mechanical packaging design of the AXBT/EA.

1. 2. 1 Summary of Interim Report R-798

The electrical design of the measuring circuit used in the AXBT/Electronics Assembly is a modification of the basic circuitry used in the highly accurate thermistor chain, designed for Johns Hopkins, with the addition of a unique self-calibration function.

Replacement of the present AXBT temperature probe with a T-7 temperature probe in the AXBT provides the capability of achieving the accuracy and depth requirements specified. However, realization of that capability required critical study of the interface between the T-7 probe and the AXBT. The RF transmitter in existing AXBT's is inexpensive and "state-of-the-art", requiring no further development to achieve the accuracy goals.

In order to electrically interface the T-7 probe to the RF transmitter, a bridge circuit and voltage controlled oscillator must be used to supply the RF transmitter with a modulation frequency proportional to temperature. The interface could have been achieved in two ways.

One method involved the use of a bridge circuit of high quality, instrumentation operational amplifiers, many precision resistors ( $\pm 0.01\%$ ,  $\pm 5$  PPM), a stable, absolute value of reference voltage of high accuracy, and a high accuracy, voltage-controlled oscillator ( $\pm 2\%$ ). All of these components must be accurate over a wide temperature range ( $-40$  to  $+50^{\circ}\text{C}$ ) and for long periods (years). This is an expensive option because of the high quality components used in the circuit.

The other, unique, method involves the use of a bridge circuit of general quality operational amplifiers, standard resistors ( $\pm 1\%$ ,  $\pm 100$  PPM), a noncritical reference voltage source, and a voltage-controlled oscillator with good linearity but not high accuracy. Less expensive components can be used in this method because it relies on a Sippican-designed self-calibrating

feature. Immediately prior to measuring, the circuit would self-calibrate using three (3) high-quality reference components to provide the requisite precise frequency outputs at the high and low ends of the temperature measurement range. This self-calibration would remove the errors incurred by using low-accuracy components over a wide range of ambient temperatures. In this manner, it then becomes sufficient for the components to have good short term stability ( $\approx 2$  minutes).

Due to the large quantities of SXBT's used and the fact that they are expendable, unit cost is a major factor to be considered in the choice of design direction. The unique self-calibrating concept was chosen due to its inherent cost advantage (three (3) high quality components versus several dozen high quality components required for the first method described).

In order to mechanically interface the T-7 probe to the AXBT, a conceptual packaging design was required. The design chosen uses as much of the AXBT package, as presently configured, as possible and places the T-7 probe, electrical interface circuitry, and housing (AXBT/EA) in the space presently occupied

by the temperature probe. Environmental testing was conducted to confirm the ability of the T-7 probe to withstand all storage and operating environments encountered by the AXBT.

### 1. 2. 2 AXBT/EA Mass Production Considerations

In October 1976, the contract was expanded to include investigation of the most economical way to mass produce the AXBT/EA. The major area of interest was the design of the electronics. Hybrid circuits and Large Scale Integration in conjunction with discrete components were investigated (with the main emphasis being placed on Large Scale Integration) to determine cost in production. A computer program was written to determine component accuracies required.

Mechanical parts were designed to obtain accurate estimates of tooling and piece part costs. The T-7 probe was packaged in a water-resistant housing. This provides improved protection against icing upon water entry after aircraft launch at very low temperatures. This will permit use in an updated buoy for higher altitude aircraft (lower temperature) should that become a requirement.

## 2.0 DESIGN REQUIREMENTS

### 2.1 Power Requirements

The AXBT/EA requires a bipolar battery capable of supplying approximately 30 ma. of current. The bipolar source is needed because of the seawater ground required to current sink the bridge circuit. This circuit concept is basic to the XBT design.

The breadboard suitable for integration requires a +13V, -7V supply with a tolerance of +15% for the duration of the self-calibration and measurement cycle, i. e. approximately 150 seconds. However, power requirements are flexible and other combinations are possible.

### 2.2 Mode Sequencing

Proposed mode sequencing is as follows. As with the power requirements, this is not fixed but may change as required for an effective sonobuoy interface.

2.2.1 Battery activation starts a timing sequence in the AXBT/EA which initiates self-calibration after a controlled delay to allow circuit "warm-up".

2.2.2 Self-calibration begins melting a fused anchor wire holding the T-7, which releases soon after self-calibration.

2. 2. 3 A switch closes upon sensing probe release which begins modulation of the carrier, signaling the start of probe descent.

2. 3 Electrical Interface

Four leads are provided for electrical interface. They will be terminated as follows:

+ Battery Voltage

- Battery Voltage

Seawater Ground (Common)

Audio Signal

2. 4 Mechanical Interface

The goal of the mechanical interface design was to provide a low-cost AXBT/EA with a minimal impact on the remaining parts of an SSQ-36 or 41. In the production design, the electromechanical interface can be finalized after appropriate discussion with the sonobuoy manufacturers.

### 3.0 INVESTIGATION OF HYBRID CIRCUITS

#### 3.1 Technique

Thin film hybrids consist of a ceramic substrate upon which a circuit pattern and resistors are deposited either by vacuum evaporation or sputtering. Silicon devices and capacitors are then bonded to the substrate and interconnects made with fine wire as required. This is a relatively high labor process which requires the purchase and mounting of individual components (except resistors). Its main advantage as a process is in size, where individual components can all be mounted in one sealed package, not in individual packages.

#### 3.2 Results

Discussions were conducted with two thin-film hybrid manufacturers. Both manufacturers indicated that thin-film hybrids were too expensive for this product.

One manufacturer, Mini-Systems Incorporated, indicated that the approximate cost of a custom hybrid for the entire circuit would approach or exceed the cost of the same circuit composed of discrete components mounted on a printed wiring board. This cost was estimated at in excess of \$100.00.

The second manufacturer, Hycomp, Inc., was asked to quote on manufacturing a custom thin-film resistor network. This network would

R-817

The Sippican Corporation

be packaged in a 14-pin DIP (Dual In-line Package) for mounting on a printed wiring board and would replace several discrete resistors. The cost for this network in production quantity (20K units) was estimated at \$8.25. No further consideration was given to this manufacturing technique.

#### 4.0 INVESTIGATION OF A CUSTOM INTEGRATED CIRCUIT ON A PRINTED WIRING BOARD

##### 4.1 Technique

This approach centered around a custom integrated circuit which would include as much of the circuitry as possible. This circuit would be mounted in a DIP package for assembly into a printed wiring board. Integrated Injection Logic (I<sup>2</sup>L) was chosen as the process due to its low power drain and its unique ability to include both digital and analog circuitry on the same chip, eliminating the need for two custom integrating circuits, one digital and one analog for the AXBT/EA.

##### 4.2 Approach

To obtain an accurate projected cost of an AXBT/EA and an accurate count of what circuitry could be included in the custom integrated circuit, a subcontract was awarded to Siltronics, Ltd., a custom integrated circuit designer and manufacturer.

In order to maximize the integrable components and minimize the total cost of the AXBT/EA, Siltronics adapted the Sippican circuitry to maintain its functions but modified the circuit elements required to accomplish these functions. Siltronics built a functional breadboard of the new circuit and supplied it to Sippican for evaluation.

#### 4.3 Limitations

The I<sup>2</sup>L technology places the following limitations on resistor and capacitor values which may be integrated, leakage currents of switches, and resistor tolerances:

- o Resistor tolerances are limited to 20% on absolute values; however, resistor pairs can "track" to within 1%. All resistors which require closer tolerances cannot be integrated and must be priced as discrete resistors mounted on the printed wiring board.

- o Resistors are limited to a maximum value of 30k ohms to conserve chip area.

- o Capacitors are limited to a maximum of 20pf.

- o Switching circuitry requiring low leakage currents cannot be integrated.

#### 4.4 Results

A functional breadboard supplied by Siltronics was received and tested at Sippican. All testing of the board was satisfactory.

The circuitry described in R-798 had been designed around standard commercial components. The Siltronics functional breadboard provided for the incorporation of several circuit functions with simplified circuitry.

The I<sup>2</sup>L design resulted in a factor of 2 improvement in linearity attributable to the use of a V.C.O. design optimized for this application.

Components identified as not integrable in the custom circuit are as follows:

- 15 Capacitors
- 15 Resistors
- 2 CMOS Quad Switches
- 1 Crystal

These components would remain external to the custom circuit and would be mounted on a printed circuit board.

This decrease from  $\approx$ 140 components in the original breadboard to 34 components greatly decreases the cost of both materials and labor to produce an AXBT/EA.

The good performance (see Section 5) and low cost make the custom integrated circuit the only feasible alternative for the AXBT/EA. All costing information in Section 8 is based on this approach.

## 5.0 COMPUTER ANALYSIS

### 5.1 Approach

After initial discussions with hybrid manufacturers and Siltronics, it became apparent that the only economically feasible approach to the circuit configuration was a custom integrated circuit on a printed wiring board. All work in the computer analysis of the circuit was based on determining which bridge resistors could be integrated and what tolerances were required for the resistors that could not be integrated.

### 5.2 Technique

The technique used in the computer analysis was similar to that described in Section 6.3 of R-798. In this case, however, resistors were not analyzed individually. Most bridge resistors act as sets in which only the ratio of their values affects accuracy. Resistors numbers are referenced to Sippican Report R-781.

All eight resistor sets were analyzed to ensure that each was independent of the other sets. Each set was then varied while all others were held fixed. Results of all sets were R.S.S.'d to determine the overall bridge circuit errors.

Calibration resistor errors were then calculated as in Section 6.2 of R-798 for several available resistor set tolerances and the results R.S.S.'d with the bridge errors.

Linearizing resistor (R1) errors were then calculated for the several available resistor tolerances. Quartz crystal, supply voltage, and T-7 probe error is the same as that described in Section 6.7 of R-798.

V.C.O. linearity error is approximately one-half that described in Section 6.4 of R-798 due to the improvement made in the V.C.O. circuitry.

### 5.3 Results (Reference Sippican Drawing D213827)

All bridge resistors were found to be perfect sets; that is, only their ratio was important, except the resistor pair R2-R11. This pair, while partially canceling errors, is not a pure ratio pair. The bridge tolerance analysis program was run once to determine the effect of all resistors being integrated (20% tolerance on absolute value, 1% tracking). The resulting mid-scale error was 3.5°C. The program was then modified to allow R2 and R11 to be external to the integrated circuit.

Figures 5.1 through 5.8 depict the results of several pertinent combinations of R2-R11 and calibration resistor tolerance combined with the bridge resistor R3 through R10 and R12 through R16 at 20% tolerance, 1% tracking.

The goal of this portion of the analysis was to determine the most cost effective tolerance combination which would result in an error of .12°C or less. This will result in a total R.S.S. error of approximately .15°C at the 3 $\sigma$  point.

Figure 5.1 shows the best combination. R2 and R11 are 1% and the calibration resistors are .1%, 30 PPM.

Figures 5.2 through 5.8 show other combinations that either do not meet the desired accuracy or that require resistors of greater precision (more costly) than those of the Figure 5.1 combination.

Figures 5-9 through 5-12 show the effect of varying the linearizing resistor tolerance. The goal was a mid-scale deviation of .05°C or less (to result in the .15°C total error). Figure 5-11 shows the best trade off. A 1% linearizing resistor results in a mid-scale error of .038°C.

#### 5.4 Sum of the Errors

The total sum of errors at the 3 $\sigma$  point considered in this program is summarized below.

SOURCE OF ERROR	Error in Degrees Celsius (R. S. S. )		
	-2.22	16.67	35.55
Quartz Crystal	± .0045	± .0068	± .009
Bridge and Calibration	± .068	± .098	± .094
Linearizing Resistor	--	± .038	--
V. C. O.	--	± .012	--
Supply Voltage Variation	± .006	± .009	± .014
T-7 XBT Probe	± .120	± .100	± .120
R. S. S. Total @ 3 $\sigma$	± .139	± .146	± .153

AXBT BRIDGE TOLERANCE

BRIDGE RESISTOR TOLERANCE IS 20 %      DEVIATION IN DEGREES C.

BRIDGE MATCHING IS GOOD TO 1 %

TOLERANCE OF R2 AND R11 IS 1 %

HIGH CAL. RES. IS .1% AT 30 P.P.M.

LOW CAL. RES. IS .1% AT 30 P.P.M.

LOW DEV	MID DEV	HIGH DEV	RESISTORS
0.00775	0.01854	0.02105	(R9, R10)
-0.01472	0.02460	-0.03318	(R3, R4)
-0.00059	0.00814	-0.00162	(R7, R8)
0.00059	0.00796	0.00161	(R5, R6)
-0.00602	0.00605	-0.00602	(R12, R16)
-0.00986	0.00987	-0.00986	(R13, R15)
0.00774	0.00775	0.00774	(R14, R15)
0.00000	0.05177	0.00000	(R2, R11)

TOTAL BRIDGE RESISTOR R.S.S. ERRORS

LOW	MID	HIGH
0.02171	0.06288	0.03790

CALABRATION RESISTOR ERRORS

LOW	MID	HIGH
0.06489	0.07563	0.08637

R.S.S. OF BRIDGE ERRORS AND CAL. RES. ERRORS

LOW	MID	HIGH
0.06843	0.09835	0.09432

\*\*\*COMPLETE\*\*\*

AXBT BRIDGE TOLERANCE

BRIDGE RESISTOR TOLERANCE IS 20 % DEVIATION IN DEGREES C.

BRIDGE MATCHING IS GOOD TO 1 %

TOLERANCE OF R2 AND R11 IS 1 %

HIGH CAL. RES. IS .1% AT 50 P.P.M.

LOW CAL. RES. IS .1% AT 50 P.P.M.

LOW DEV	MID DEV	HIGH DEV	RESISTORS
0.00775	0.01854	0.02105	(R9, R10)
-0.01472	0.02440	-0.02818	(R3, R4)
-0.00059	0.00814	-0.00162	(R7, R8)
-0.00059	0.00796	0.00161	(R5, R6)
-0.00602	0.00605	-0.00602	(R12, R16)
-0.00986	0.00987	-0.00986	(R13, R15)
0.00774	0.00775	0.00774	(R14, R15)
0.00000	0.05177	0.00000	(R2, R11)

TOTAL BRIDGE RESISTOR R.S.S. ERRORS

LOW	MID	HIGH
0.02171	0.06288	0.03790

CALABRATION RESISTOR ERRORS

LOW	MID	HIGH
0.07430	0.10991	0.12551

R.S.S. OF BRIDGE ERRORS AND CAL. RES. ERRORS

LOW	MID	HIGH
0.09677	0.12662	0.13111

\*\*\*COMPLETE\*\*\*

## AXBT BRIDGE TOLERANCE

BRIDGE RESISTOR TOLERANCE IS 20 % DEVIATION IN DEGREES C.

BRIDGE MATCHING IS GOOD TO 1 %

TOLERANCE OF R2 AND R11 IS 5 %

HIGH CAL. RES. IS .1% AT 30 P.P.M.

LOW CAL. RES. IS .1% AT 30 P.P.M.

LOW DEV	MID DEV	HIGH DEV	RESISTORS
0.00775	0.01854	0.02105	(R9, R10)
-0.01472	0.02460	-0.02818	(R3, R4)
-0.00057	0.00614	-0.00162	(R7, R8)
0.00059	0.00796	0.00161	(R5, R6)
-0.00602	0.00605	-0.00602	(R12, R16)
-0.00736	0.00987	-0.00986	(R13, R15)
0.00774	0.00775	0.00774	(R14, R15)
0.00000	0.11252	0.00000	(R2, R11)

TOTAL BRIDGE RESISTOR R.S.S. ERRORS

LOW	MID	HIGH
0.02171	0.11804	0.03790

CALIBRATION RESISTOR ERRORS

LOW	MID	HIGH
0.06489	0.07563	0.08637

R.S.S. OF BRIDGE ERRORS AND CAL. RES. ERRORS

LOW	MID	HIGH
0.06843	0.14019	0.07432

\*\*\*COMPLETE\*\*\*

AXBT BRIDGE TOLERANCE

BRIDGE RESISTOR TOLERANCE IS 20 % DEVIATION IN DEGREES C.

BRIDGE MATCHING IS GOOD TO 1 %

TOLERANCE OF R2 AND R11 IS .1 %

HIGH CAL. RES. IS .1% AT 30 P.P.M.

LOW CAL. RES. IS .1% AT 30 P.P.M.

LOW DEV	MID DEV	HIGH DEV	RESISTORS
0.00775	0.01854	0.02105	(R9, R10)
-0.01472	0.02460	-0.02818	(R3, R4)
-0.00059	0.00814	-0.00162	(R7, R8)
0.00059	0.00776	0.00161	(R5, R6)
-0.00602	0.00605	-0.00602	(R12, R16)
-0.00986	0.00987	-0.00986	(R13, R15)
0.00774	0.00775	0.00774	(R14, R15)
0.00000	0.00584	0.00000	(R2, R11)

TOTAL BRIDGE RESISTOR R.S.S. ERRORS

LOW	MID	HIGH
0.02171	0.03616	0.03790

CALIBRATION RESISTOR ERRORS

LOW	MID	HIGH
0.06489	0.07563	0.08637

R.S.S. OF BRIDGE ERRORS AND CAL. RES. ERRORS

LOW	MID	HIGH
0.06843	0.08363	0.09432

\*\*\*COMPLETE\*\*\*

AXBT BRIDGE TOLERANCE

### AXBT BRIDGE TOLERANCE

BRIDGE RESISTOR TOLERANCE IS 20 %      DEVIATION IN DEGREES C.

BRIDGE MATCHING IS GOOD TO 1 %

TOLERANCE OF R2 AND R11 IS .5 %

HIGH CAL. RES. IS .1% AT 30 P.P.M.

LOW CAL. RES. IS .1% AT 30 P.P.M.

LOW DEV	MID DEV	HIGH DEV	RESISTORS
0.00775	0.01854	0.02105	(R9, R10)
-0.01472	0.02460	-0.02818	(R3, R4)
-0.00059	0.00814	-0.00162	(R7, R8)
-0.00059	0.00796	0.00161	(R5, R6)
-0.00602	0.00605	-0.00602	(R12, R16)
-0.00286	0.00287	-0.00286	(R13, R15)
0.00774	0.00775	0.00774	(R14, R15)
0.00000	0.02781	0.00000	(R2, R11)

TOTAL BRIDGE RESISTOR R.S.S. ERRORS

LOW	MID	HIGH
0.02171	0.04524	0.03790

CALABRATION RESISTOR ERRORS

LOW	MID	HIGH
0.06489	0.07563	0.08637

R.S.S. OF BRIDGE ERRORS AND CAL. RES. ERRORS

LOW	MID	HIGH
0.06243	0.08813	0.09432

\*\*\*COMPLETE\*\*\*

### AXBT BRIDGE TOLERANCE

BRIDGE RESISTOR TOLERANCE IS 20 %      DEVIATION IN DEGREES C.

BRIDGE MATCHING IS GOOD TO 1 %

TOLERANCE OF R2 AND R11 IS 1 %

HIGH CAL. RES. IS .5% AT 10 P.P.M.

LOW CAL. RES. IS .5% AT 10 P.P.M.

LOW DEV	MID DEV	HIGH DEV	RESISTORS
0.00775	0.01854	0.02105	(R9, R10)
-0.01472	0.02460	-0.02818	(R3, R4)
-0.00059	0.00814	-0.00162	(R7, R8)
-0.00059	0.00796	0.00161	(R5, R6)
-0.00602	0.00605	-0.00602	(R12, R16)
-0.00986	0.00987	-0.00986	(R13, R15)
0.00774	0.00775	0.00774	(R14, R15)
0.00000	0.05177	0.00000	(R2, R11)

TOTAL BRIDGE RESISTOR R.S.S. ERRORS

LOW	MID	HIGH
0.02171	0.06288	0.03790

CALABRATION RESISTOR ERRORS

LOW	MID	HIGH
0.18948	0.22083	0.25218

R.S.S. OF BRIDGE ERRORS AND CAL. RES. ERRORS

LOW	MID	HIGH
0.19072	0.22961	0.25501

\*\*\*COMPLETE\*\*\*

**AXBT BRIDGE TOLERANCE**

BRIDGE RESISTOR TOLERANCE IS 20 %      DEVIATION IN DEGREES C.

BRIDGE MATCHING IS GOOD TO 5 %

TOLERANCE OF R2 AND R11 IS 1 %

HIGH CAL. RES. IS .1% AT 30 P.P.M.

LOW CAL. RES. IS .1% AT 30 P.P.M.

LOW DEV	MID DEV	HIGH DEV	RESISTORS
0.03856	0.09009	0.10414	(R9, R10)
-0.07560	0.12699	-0.14543	(R3, R4)
-0.00304	0.04230	-0.00830	(R7, R8)
0.00296	0.03966	0.00802	(R5, R6)
-0.03066	0.03393	-0.03066	(R12, R16)
-0.04935	0.04938	-0.04935	(R13, R15)
0.03872	0.04026	0.03872	(R14, R15)
0.00000	0.05177	0.00000	(R2, R11)

**TOTAL BRIDGE RESISTOR R.S.S. ERRORS**

LOW	MID	HIGH
0.10998	0.18841	0.19237

**CALABRATION RESISTOR ERRORS**

LOW	MID	HIGH
0.06489	0.07563	0.08637

**R.S.S. OF BRIDGE ERRORS AND CAL. RES. ERRORS**

LOW	MID	HIGH
0.12770	0.20302	0.21087

\*\*\*COMPLETE\*\*\*

R-817

The Sippican Corporation

AXBT BRIDGE TOLERANCE

BRIDGE RESISTOR TOLERANCE IS 20 % DEVIATION IN DEGREES C.

BRIDGE MATCHING IS GOOD TO 1.00000000E-02 %

TOLERANCE OF R2 AND R11 IS 1.00000000E-02 %

HIGH CAL. RES. IS .01% AT 5 P.P.M.

LOW CAL. RES. IS .01% AT 5 P.P.M.

LOW DEV	MID DEV	HIGH DEV	RESISTORS
0.00007	0.00016	0.00021	(R9, R10)
-0.00014	0.00026	-0.00027	(R3, R4)
-0.00000	0.00011	-0.00001	(R7, R8)
-0.00000	0.00004	0.00001	(R5, R6)
-0.00005	0.00006	-0.00005	(R12, R16)
-0.00009	0.00010	-0.00009	(R13, R15)
0.00007	0.00008	0.00007	(R14, R15)
0.00000	0.00055	0.00000	(R2, R11)

TOTAL BRIDGE RESISTOR R.S.S. ERRORS

LOW	MID	HIGH
0.00021	0.00066	0.00037

CALABRATION RESISTOR ERRORS

LOW	MID	HIGH
0.00743	0.01099	0.01255

R.S.S. OF BRIDGE ERRORS AND CAL. RES. ERRORS

LOW	MID	HIGH
0.00943	0.01101	0.01255

\*\*\*COMPLETE\*\*\*

## LINEARITY TOLERANCE

THE TOLERANCE OF R1 IS .01%

I(C)	ERROR(C)
-2.22	0.0000
-2.00	0.0000
-1.00	0.0000
0.00	0.0000
1.00	0.0001
2.00	0.0001
3.00	0.0001
4.00	0.0001
5.00	0.0002
6.00	0.0002
7.00	0.0002
8.00	0.0002
9.00	0.0003
10.00	0.0003
11.00	0.0003
12.00	0.0003
13.00	0.0003
14.00	0.0003
15.00	0.0003
16.00	0.0003
17.00	0.0003
18.00	0.0003
19.00	0.0003
20.00	0.0003
21.00	0.0003
22.00	0.0003
23.00	0.0003
24.00	0.0003
25.00	0.0002
26.00	0.0002
27.00	0.0002
28.00	0.0002
29.00	0.0002
30.00	0.0001
31.00	0.0001
32.00	0.0001
33.00	0.0000
34.00	0.0000
35.00	0.0000
35.55	0.0000

\*\*\*COMPLETE

## LINEARITY TOLERANCE

THE TOLERANCE OF R1 IS .5%

I(C)	ERROR(C)
-2.22	0.0000
-2.00	0.0003
-1.00	0.0021
0.00	0.0037
1.00	0.0054
2.00	0.0069
3.00	0.0084
4.00	0.0098
5.00	0.0111
6.00	0.0124
7.00	0.0135
8.00	0.0145
9.00	0.0155
10.00	0.0163
11.00	0.0171
12.00	0.0177
13.00	0.0182
14.00	0.0186
15.00	0.0188
16.00	0.0190
17.00	0.0190
18.00	0.0189
19.00	0.0187
20.00	0.0184
21.00	0.0179
22.00	0.0173
23.00	0.0167
24.00	0.0159
25.00	0.0150
26.00	0.0140
27.00	0.0128
28.00	0.0116
29.00	0.0103
30.00	0.0089
31.00	0.0075
32.00	0.0059
33.00	0.0043
34.00	0.0026
35.00	0.0009
35.55	0.0000

\*\*\*COMPLETE

## LINEARITY TOLERANCE

THE TOLERANCE OF R1 IS 1%

I(C)	ERROR(C)
-2.22	0.0000
-2.00	0.0007
-1.00	0.0042
0.00	0.0075
1.00	0.0108
2.00	0.0139
3.00	0.0169
4.00	0.0197
5.00	0.0223
6.00	0.0248
7.00	0.0271
8.00	0.0292
9.00	0.0311
10.00	0.0328
11.00	0.0342
12.00	0.0355
13.00	0.0365
14.00	0.0372
15.00	0.0378
16.00	0.0381
17.00	0.0381
18.00	0.0379
19.00	0.0375
20.00	0.0369
21.00	0.0359
22.00	0.0348
23.00	0.0335
24.00	0.0319
25.00	0.0301
26.00	0.0280
27.00	0.0256
28.00	0.0234
29.00	0.0208
30.00	0.0180
31.00	0.0150
32.00	0.0119
33.00	0.0087
34.00	0.0053
35.00	0.0018
35.55	0.0000

\*\*\*COMPLETE

## LINEARITY TOLERANCE

THE TOLERANCE OF R1 IS 5%

T(C)	ERROR(C)
-2.22	0.0000
-2.00	0.0040
-1.00	0.0214
0.00	0.0383
1.00	0.0547
2.00	0.0704
3.00	0.0854
4.00	0.0997
5.00	0.1132
6.00	0.1258
7.00	0.1375
8.00	0.1482
9.00	0.1579
10.00	0.1665
11.00	0.1740
12.00	0.1803
13.00	0.1855
14.00	0.1895
15.00	0.1923
16.00	0.1939
17.00	0.1943
18.00	0.1934
19.00	0.1913
20.00	0.1880
21.00	0.1835
22.00	0.1778
23.00	0.1709
24.00	0.1629
25.00	0.1538
26.00	0.1435
27.00	0.1322
28.00	0.1198
29.00	0.1065
30.00	0.0923
31.00	0.0773
32.00	0.0614
33.00	0.0447
34.00	0.0273
35.00	0.0096
35.55	0.0000

\*\*\*COMPLETE

## 6.0 PACKAGING DESIGN

### 6.1 Purpose

In order to establish an accurate cost for the AXBT/EA in production, a detailed design drawing set was generated. This drawing package was used to obtain mechanical part costs and tooling costs.

It should be pointed out that the AXBT/EA packaging concept used for the purpose of this study results in a separate self-contained unit. However, alternative approaches should also be considered when designing the AN/SSQ-36 PIP in conjunction with sonobuoy manufacturers. For example, it may be desirable to house the electronics within the buoy on a printed circuit card and have the T-7 temperature probe and sea-keeping spool in a separate housing.

### 6.2 Description

The packaging concept chosen to price consists of a housing, T-7 probe, probe cap, end plate, sea-keeping spool, switch and vent mechanism and release mechanism (See Figure 6.1).

The housing is a two-piece molded plastic cylinder. Features for mounting to the SSQ-36 buoy are molded into the parts.

The probe cap is a plastic molding with a vent hole for pressure equalization which keeps the probe in the housing prior to probe release.

The end plate is a plastic molding which seals the electronics chamber in which is a printed wiring board with all electronics.

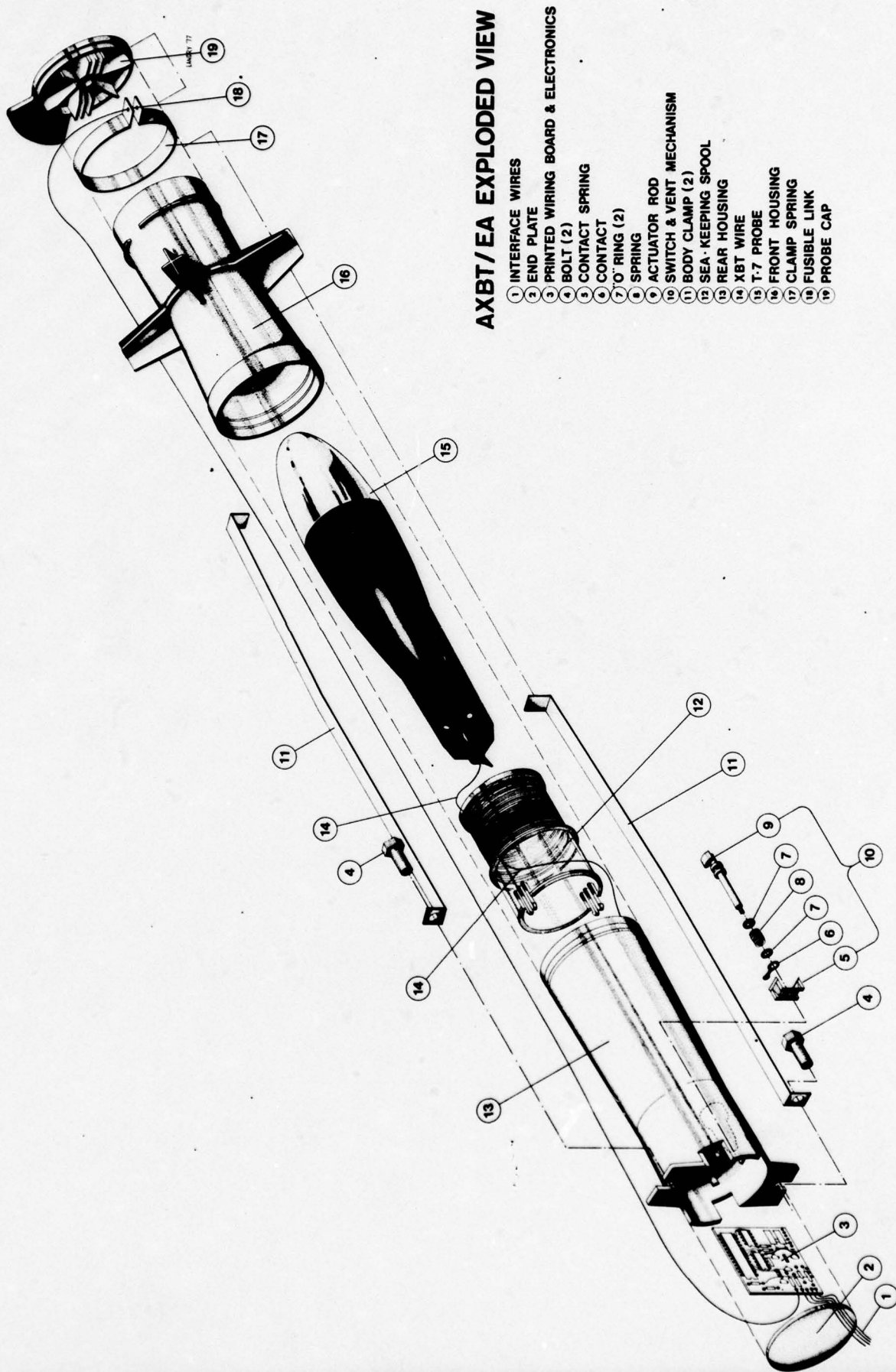


Figure 6-1

The sea-keeping spool is a plastic molding which holds the T-7 probe firmly at the afterbody and contains approximately 200 feet of magnet wire. Testing was conducted in sea state 3, which confirmed the need for this spool to prevent damage to the magnet wire due to the action of wind and waves on the buoy.

The release mechanism consists of two body clamps, a clamp spring and a fusible link. The body clamps are spring-loaded to the open (outboard) position but held against the housing prior to probe release by the clamp spring. The clamp spring is similarly spring-loaded to the open position but held closed by the fusible link. When the link breaks, the clamp spring and body clamps move to the open position. This releases the probe cap and T-7 probe.

The switch and vent mechanism consists of a molded plastic actuator rod, two "O"-rings, spring, contact spring and contact. The actuator rod is spring-loaded against one fin of the T-7 probe. When the probe exits the housing, the actuator rod moves downward until the contact spring and contact make a connection, starting carrier modulation. The actuator rod is also a piston seal which closes a vent hole in the housing prior to release. As the rod moves it opens the vent allowing the housing area to flood. This lessens the requirement for added ballast to keep the buoy upright. The two "O"-rings seal the electronics chamber and housing area.

6.3 Summary of Launch Sequence

- (a) Fused anchor wire parts.
- (b) Clamp spring opens.
- (c) Body clamps open.
- (d) Probe cap and T-7 probe exit housing.
- (e) Actuator rod:
  - (1) Closes switch to start modulation.
  - (2) Opens vent to flood housing.

## 7.0 AXBT/EA RELIABILITY & ACCURACY

The incorporation of the AXBT/EA subassembly into the AN/SSQ-36 will require high reliability and accuracy both from the AXBT/EA electronics and from the T-7 probe. Based on Sippican's experience obtained in the design and packaging of satellite electronics, we can expect to achieve reliabilities of .999 on the electronics portion of the AXBT/EA. These high reliabilities are achievable because of the small number of active elements involved. Life cycle testing under power will be conducted using an appropriate number of units to demonstrate this reliability. In addition, all production units will undergo burn-in in order to screen out infant mortalities.

The reliability and accuracy of the T-7 probe portion of the AXBT/EA must be both demonstrated and controlled throughout production. Fortunately, The T-7 probe subassembly is a testable item. Testing, therefore, will be the basis for establishing and controlling reliability and accuracy.

We should address accuracy first, since this parameter can be tested easily at the part level. The accuracy of a T-7 probe is primarily dependent upon one part, the thermistor.

Each thermistor is independently calibrated during its manufacture. Upon receipt at Sippican, the thermistors are sample tested for their temperature characteristic to an AQL of 1%. All XBT's, after assembly of the thermistor, are tested at a 100% level for temperature characteristic and

defective thermistor removal. We do not anticipate changing this testing method at the present time.

The five year life requirement will require an investigative testing program. This test program will require the temperature testing of 300 thermistors spanning 5 years, using 5 thermistors from each month. Sippican has serialized thermistors with appropriate data covering five years. If this investigative test program determines that the five year life requirement cannot be met with the normal distribution of thermistors, we can establish additional testing upon receipt that would select thermistors capable of meeting life requirements from the total population. Selection testing is typical of electronic parts throughout the industry.

Reliability of the T-7 probe is dependent upon its major failure mode which is wire leakage. Although we have several methods for testing to determine leakage, the most efficient testing method is destructive. We do use a vigorous wire screening test program for wire destined for submarine XBT's (SSXBT's). The wire screening was found to be necessary because of the stringent voltage and pressure stresses imposed by the unique SSXBT application. We also have had, for the past two years, the wire coating process under tight control. With the invoking of tight process controls, we have brought about significant improvement of wire quality with respect to leakage problems.

Another consideration is the small amount of wire on the AXBT T-7

relative to our standard product T-7. The AXBT T-7 contains only 110  $\pm$ 1 grams of wire which is 46% of the total wire of an entire standard T-7 XBT which includes both probe and shipboard wire spools. Wire leakage is thus less likely to occur. Our testing indicates that reliability for the standard T-7 is on the order of .95 under probe launch conditions similar to those which will be experienced by the AXBT/EA. The shorter length of wire associated with the AXBT/EA indicate that our failure rate for this device should be less than half that associated with the standard T-7; therefore, a reliability of .98 is achievable.

In light of the above, we recommend the following test program. This test program is made up of three phases of which the second phase may be deemed unnecessary upon completion of the first phase.

**Phase 1. Reliability Demonstration Testing**

Establish the current reliability of the T-7 probe sub-assembly. The results of this test will enable the development of a sampling test to be used for verifying the retention of reliability during production.

We recommend the building and destruct testing of a 300 item sample. By testing to three times the reliability, we can ensure the presence of sufficient data for analysis purposes.

If the results of this testing demonstrates a reliability of .98 or greater, we can eliminate phase 2 and proceed directly to phase 3.

**Phase 2. Reliability Demonstration Testing**

This testing phase is dependent upon the results of phase

1. With a reliability less than required existing using standard manufacturing methods we will have to alter these methods. Another test sample of 300 items would again be built and destructively tested. This second test sample would use wire that had been subject to our wire screening process to a degree sufficient to achieve the required reliability.

### Phase 3. Reliability Acceptance Testing

Once the reliability has been established by demonstration it becomes necessary to retain the demonstrated level. We recommend the use of sequential sampling for acceptance testing. Sequential sampling requires testing of fewer items than multiple or single sampling. This procedure is typically applied to one-shot devices where the sample size and not the duration of the test is the factor in selecting a particular sampling plan.

In order to develop a sequential sampling plan the following factors must be defined:

- (1) Specified reliability for the T-7 probe subassembly.
- (2) Minimum acceptable reliability. A value that must be less than (1) above.
- (3) Consumer's risk stated as a probability of accepting a bad lot.
- (4) Producer's risk stated as a probability of rejecting a good lot.
- (5) Lot size.

The sampling levels can be staged by using a higher level (i. e. 8%) for five accept decisions and a lower level (i. e. 5%) thereafter.

## 8.0 PRODUCTION QUANTITY PRICING

### 8.1 Unit Costs

Utilizing the design drawings for the AXBT/EA described in Section 6.0 and a list of electrical components generated from the results of Section 4.0, Sippican's Purchasing Department was supplied with the necessary information to obtain production quantity prices. The cost of manufacturing and testing was determined by the manager of manufacturing after a review of the AXBT/EA design package and discussions with engineering and quality assurance personnel. The resulting detailed costs are delineated in Table 8-1.

### 8.2 Tooling Costs

In order to minimize the recurring cost of the piece parts of the AXBT/EA, maximum use of injection molding is utilized. With the exception of a few formed metal parts, the remainder of the mechanical parts are molded plastic. This provides low-cost, repeatable parts suitable for high volume production. The tooling cost for the custom integrated circuit will be borne by Sippican since it has applications outside of the AXBT/EA.

The cost breakdown for the nonrecurring tooling is shown in Table 8-2.

TABLE 8-1. Production Quantity Unit Costs

Quantity	20,000	10,000	1,000
<u>DIRECT MATERIAL</u>			
Mechanical Parts	\$ 1.76	\$ 1.86	\$ 4.97
Discrete Electrical Parts	5.15	5.55	8.59
Custom I.C.	3.80	4.00	5.00
Crystal	1.56	1.61	2.50
T-7 Probe Parts	3.06	3.06	3.06
Printed Wiring Board	.60	.70	.90
Shipping Container	.30	.30	.40
	<u>\$16.23</u>	<u>\$17.08</u>	<u>\$25.42</u>
<u>DIRECT LABOR</u>			
	\$ 2.37	\$ 2.37	\$ 3.91
Overhead @ 180%	4.27	4.27	7.04
	<u>\$ 6.64</u>	<u>\$ 6.64</u>	<u>\$10.95</u>
Labor Thru Overhead	\$ 6.64	\$ 6.64	\$10.95
Direct Material	16.23	17.08	25.42
	<u>\$22.37</u>	<u>\$23.72</u>	<u>\$36.37</u>
G & A @ 25%	5.72	5.93	9.09
	<u>\$28.59</u>	<u>\$29.65</u>	<u>\$45.46</u>
Fee @ 15%	4.29	4.45	6.82
	<u>\$32.88</u>	<u>\$34.10</u>	<u>\$52.28</u>

TABLE 8-2. Production Quantity Tooling Cost

Tools for Molded Plastic Parts	\$53,100.00
Tool for Shipping Container	1,800.00
Tool for Custom I. C.	Sippican Owned
Tool Set Up Charge for Formed Parts	650.00
	<hr/>
	\$55,550.00
G & A @ 25%	13,887.50
	<hr/>
	\$69,437.50
Fee @ 15%	10,415.63
	<hr/>
COST	<b>\$79,853.13</b>

## 9.0 CONCLUSIONS

As a result of the program to investigate the most economical ways to produce AXBT Electronic Assemblies in production quantities while maintaining accuracy, Sippican explored several approaches. The investigation of various approaches resulted in a cost-effective technique of simplifying the electronics and packaging the AXBT/EA to withstand the environments imposed upon an AN/SSQ-36 PIP.

The mechanical packaging design takes advantage of Sippican's several years of experience in the development of SXBT's and especially the Submarine Launched XBT, which most closely represents the packaging and environmental constraints of an AXBT.

After pursuing the methods of integrating the electronics into the lowest cost package without degrading the accuracy of the feasibility breadboard, an approach was chosen and a breadboard was fabricated. The resulting electronics package that was found most cost effective without degradation in accuracy was a Custom Integrated Circuit with a small quantity of discrete components which could not be made integrable on the custom I.C. This decision was made after a thorough investigation of the microelectronics field including Custom Hybrid Circuits, MSI (Medium Scale Integration) and various techniques for LSI (Large Scale Integration) on thick and thin films.

## 10.0 RECOMMENDATIONS

After two years of continuing work with ONR, NADC, NAAFI and manufacturers of sonobuoys on an improved version of an AN/SSQ-36 with increased capabilities of depth, accuracy, and gradient resolution, Sippican recommends that a batch of 1,000 AN/SSQ-36 PIP AXBT's be manufactured for performance and reliability demonstration. This batch of 1,000 AXBT's could be divided into two lots of 500 units, wherein two sonobuoy manufacturers would subcontract to Sippican for delivery of 500 AXBT/Electronics Assemblies each.

The AXBT/EA will be designed and manufactured in accordance with the features delineated in this report except as modified for integration into the sonobuoy. The components used in the unit will be manufactured from production tooled parts. In order to achieve success in the program, close coordination and liaison must be established and maintained between Sippican and the sonobuoy manufacturers.

APPENDIX

R-798

Interim Report - Feasibility Study AXBT/EA

Prepared Under  
CONTRACT N00014-76-C-0230

29 October 1976

R-798  
Interim Report-Feasibility Study  
"AXBT/EA"  
Airborne Expendable Bathythermograph  
Electronics Assembly

By

C. Barry Tirrell  
Ralph G. Washburn  
Michael J. Balboni

The Sippican Corporation  
Marion, Massachusetts

## ABSTRACT

The Sippican Corporation conducted a study for the Office of Naval Research to investigate the feasibility of incorporating a model T-7 XBT and a self-calibrating interface circuit into the AN/SSQ-36 Sonobuoy. This would improve the accuracies of the buoy to those of the XBT System ( $\pm 0.2^{\circ}\text{C}$ ,  $\pm 2\%$  of depth) and increase the depth capability to 760 meters.

Feasibility was proven both electrically and mechanically. Further investigation of the costs associated with this improvement is required.

## TABLE OF CONTENTS

<u>Section</u>		<u>Page</u>
	ABSTRACT	i
1.0	INTRODUCTION	1-1
2.0	OBJECTIVES	2-1
3.0	PACKAGING CONCEPT	3-1
	3.1 Summary	3-1
	3.2 Designs	3-2
4.0	ELECTRICAL DESIGN	4-1
	4.1 General	4-1
	4.2 Circuit Design	4-2
5.0	BREADBOARD TEST	5-1
	5.1 Summary	5-1
	5.2 General	5-2
	5.3 Test Results	5-3
6.0	ERROR ANALYSIS	6-1
	6.1 General	6-1
	6.2 Primary Calibrating Reference Errors	6-2
	6.3 DC Bridge Circuit	6-5
	6.4 Voltage Controlled Oscillator (VCO)	6-8
	6.5 Ambient Temperature Change	6-13
	6.6 Thermistor "S" Curve Nonlinearity	6-14
	6.7 Total Sum of Errors	6-18
7.0	MECHANICAL TEST	7-1
	7.1 Summary	7-1
	7.2 Shock Test	7-1
	7.3 Vibration Test	7-17
	7.4 Probe Temperature Test	7-24
8.0	CONCLUSIONS AND RECOMMENDATIONS	8-1
APPENDIX I	Vibration Test Report	

## 1.0 INTRODUCTION

In August 1975, at the request of ONR, The Sippican Corporation submitted a proposal to investigate the feasibility of improving the accuracies and depth capability of the AN/SSQ-36 AXBT Sonobuoy ( $\pm .55^{\circ}\text{C}$ ,  $\pm 5\%$  of depth, 305 m) to the accuracies and depth capability of the Sippican Expendable Bathythermograph System using T-7 probes ( $\pm .2^{\circ}\text{C}$ ,  $\pm 2\%$  of depth, 760 m).

Replacement of the present AXBT temperature probe with a T-7 temperature probe in the AXBT provides the capability of achieving the accuracy and depth capability goals. The critical area to be studied was the interface between the T-7 probe and the AXBT.

The RF transmitter in existing AXBT's is inexpensive and "state-of-the-art." No further development in this area was required to achieve the accuracy goals.

In order to electrically interface the T-7 probe to the RF transmitter, a bridge circuit and voltage-controlled oscillator are required to supply a frequency proportional to temperature. The interface could have been achieved in two ways.

One method involves a bridge circuit of high quality, instrumentation operational amplifiers, many precision resistors ( $\pm .01\%$ ,  $\pm 5$  PPM),

and a stable, absolute value of reference voltage of high absolute accuracy, and a high accuracy, voltage-controlled oscillator ( $\pm .2\%$ ). All of these components would be required to be accurate over a wide temperature range (-40 to +50°C) and for long periods (years).

The other, unique, method involves a bridge circuit of general quality operational amplifiers, standard resistors ( $\pm 1\%$ ,  $\pm 100$  PPM), and a non-critical reference voltage source; and a voltage controlled oscillator with good linearity but not high accuracy. Immediately prior to measuring, the circuit would self-calibrate using three (3) high-quality reference components to provide the precise frequency outputs at the high and low ends of the temperature measurement range. This self-calibration would remove the errors incurred by using these low-accuracy components over a wide range of ambient temperatures. The only remaining constraint is that all components should have good short-term stability ( $\approx 2$  minutes).

Due to the high quantities of AXBT's used and the fact that they are expendable, unit cost is a major factor to be considered in the choice of design direction. The unique self-calibrating concept was chosen due to its inherent cost advantage (three (3) high-quality components versus several dozen high-quality components required for the first method described).

In order to mechanically interface the T-7 probe to the AXBT, a conceptual packaging design was required. The approach chosen was to

R-798

The Sippican Corporation

utilize as much of the AXBT package, as presently configured, as possible and place the T-7 probe, electrical interface circuitry, and housing (AXBT/EA) in the space presently occupied by temperature probe.

Environmental testing was required to confirm the ability of the T-7 probe to withstand all storage and operating environments encountered by the AXBT.

2.0 OBJECTIVES

The objectives of this study were to investigate the feasibility of achieving the improved accuracies desired for AXBT's by the utilization of Sippican's T-7 probe and self-calibrating interface circuitry.

Electrical feasibility would be proven by the reduction to practice, analysis, and operational testing of the self-calibrating circuit to the point where the desired accuracies were practical to achieve.

Mechanical feasibility would be proven by confirming that the T-7 is capable of withstanding the environmental conditions to which it could be subjected.

### 3.0 PACKAGING CONCEPT

#### 3.1 Summary

Conceptual Packaging Design of an AXBT/EA for inclusion into an AN/SSQ-36( ) was undertaken based on the following constraints:

- o Ambient temperature change of the electronics should be very slow to minimize errors due to the temperature coefficient of individual components.

- o The T-7 probe should be firmly held within the container to prevent damage from shock or vibration.

- o A Sea-Keeping Spool may be needed to prevent damage to the magnet wire from wave action.

- o The T-7 probe should be kept "dry" until released to minimize icing when deployed in cold, low salinity water.

- o The release mechanism action should be initiated by means of a fused anchor wire to be compatible with present AXBT release techniques.

- o The overall package dimensions should be constrained to permit use in present and proposed AXBT configurations.

Two (2) probe release designs, based on the above constraints, were generated. One had an advantage of a short overall length, the other a smaller outside diameter. Further inputs from future specifications will be required to determine the best approach.

### 3.2 Designs

Both conceptual designs for the AXBT/EA are similar except for the release mechanism.

The electronics are fully encapsulated in epoxy to slow the change in electronics ambient temperature (see Section 6.5).

The T-7 probe is firmly held at the after body by the sea-keeping spool, which supports the T-7 afterbody in the same manner as the proven SSXBT design, and nose by the probe cap within an aluminum tube, to prevent damage from shock or vibration (see Sections 7.2 and 7.3). The sea-keeping spool is included to prevent failures of the magnet wire near the buoy by the action of wind or waves on the buoy. The sea-keeping spool is equivalent to the canister spool in an XBT. It will dereel wire to prevent motion of the buoy relative to the water from stretching and breaking the wire. A further test is required to determine whether this spool is necessary. If it is not, an afterbody support will replace it in the AXBT/EA design. Aluminum was chosen for the housing for light weight and high strength. If greater weight is required for buoy stability, the housing could be fabricated from steel.

The housing is watertight except for a small vent hole in the probe cap. This minimizes problems due to icing by keeping the T-7 probe dry prior to release (see Section 7.4). The vent hole allows pressure equal-

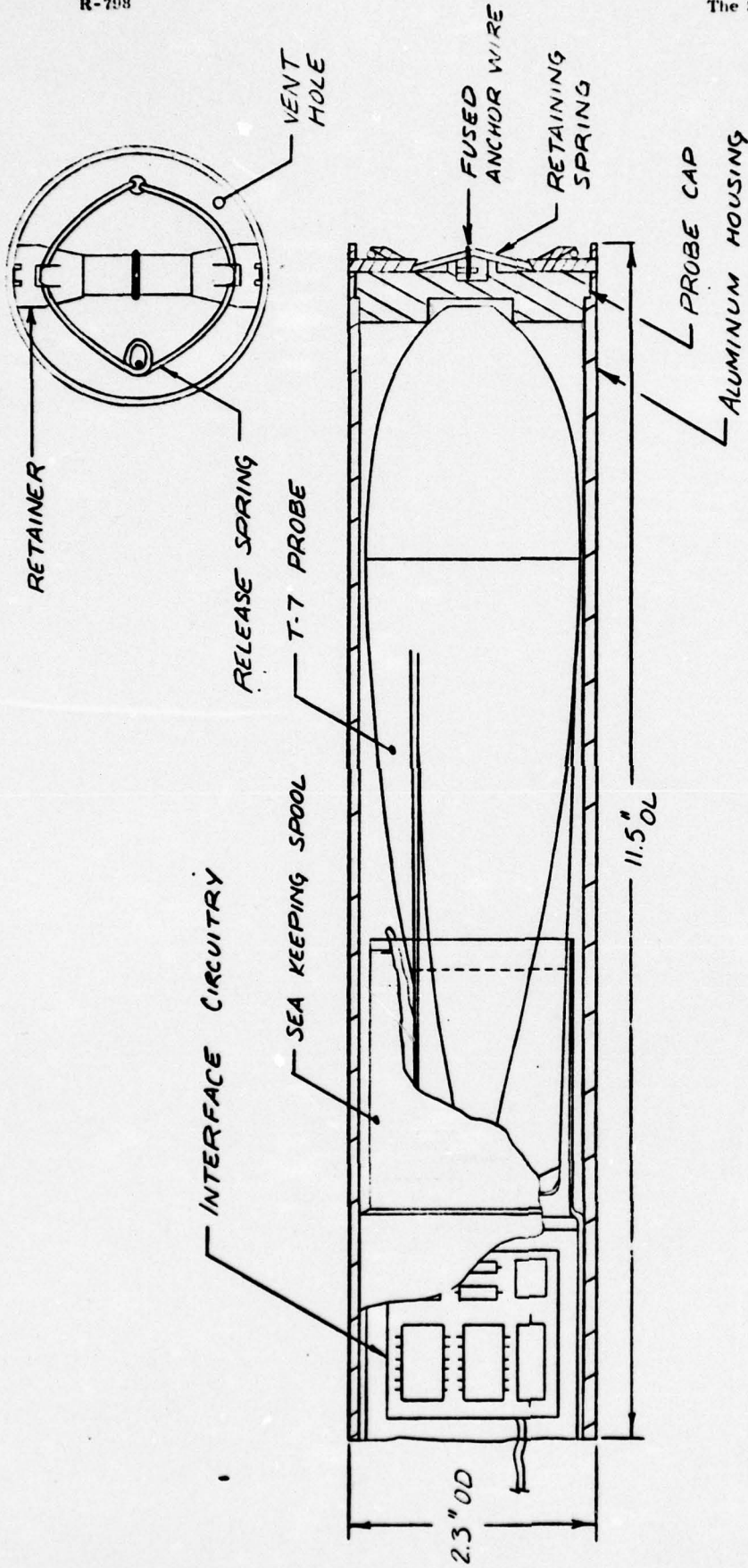
ization between the inside of the housing and ambient pressure. This prevents probe release failures due to ambient pressure holding the probe cap in, if the housing is evacuated at altitude and cannot equalize inside-to-outside pressure rapidly during the descent to the ocean surface.

Both release mechanism actions are initiated by a fused anchor wire to be compatible with the present AXBT release technique.

The first release mechanism (see Fig. 3-1) (which is longer but smaller in outside diameter than other) consists of a fused anchor wire, retainer spring, two retainers, and release spring. The retainers lock the probe cap to the housing by protruding into slots. They are spring-loaded to the retracted (release) position by the release spring. Holding them in the slots is the retaining spring (a "V"-shaped piece of spring steel).

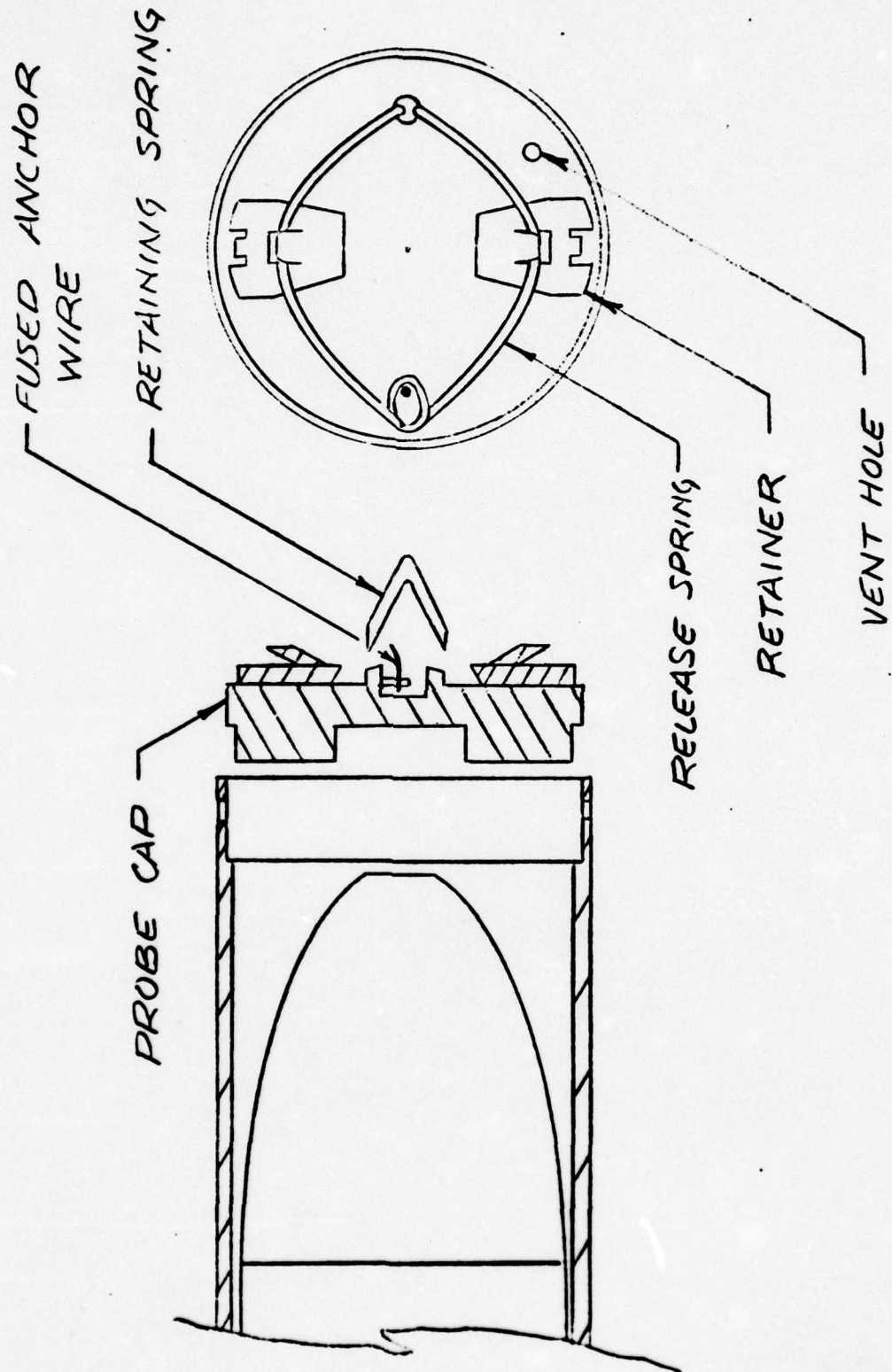
When the fused anchor wire is broken (see Fig. 3-2), the retaining spring is released and returns to its original "V" shape. This releases the retainers which are then retracted by the release spring, releasing the probe cap. The T-7 probe is then free to exit the housing and begin its descent.

The second release mechanism (see Fig. 3-3) consists of four (4) retaining pins, four (4) Bellville washer springs, a retaining ring, a release spring, a backing ring, and fused anchor wire. The retaining



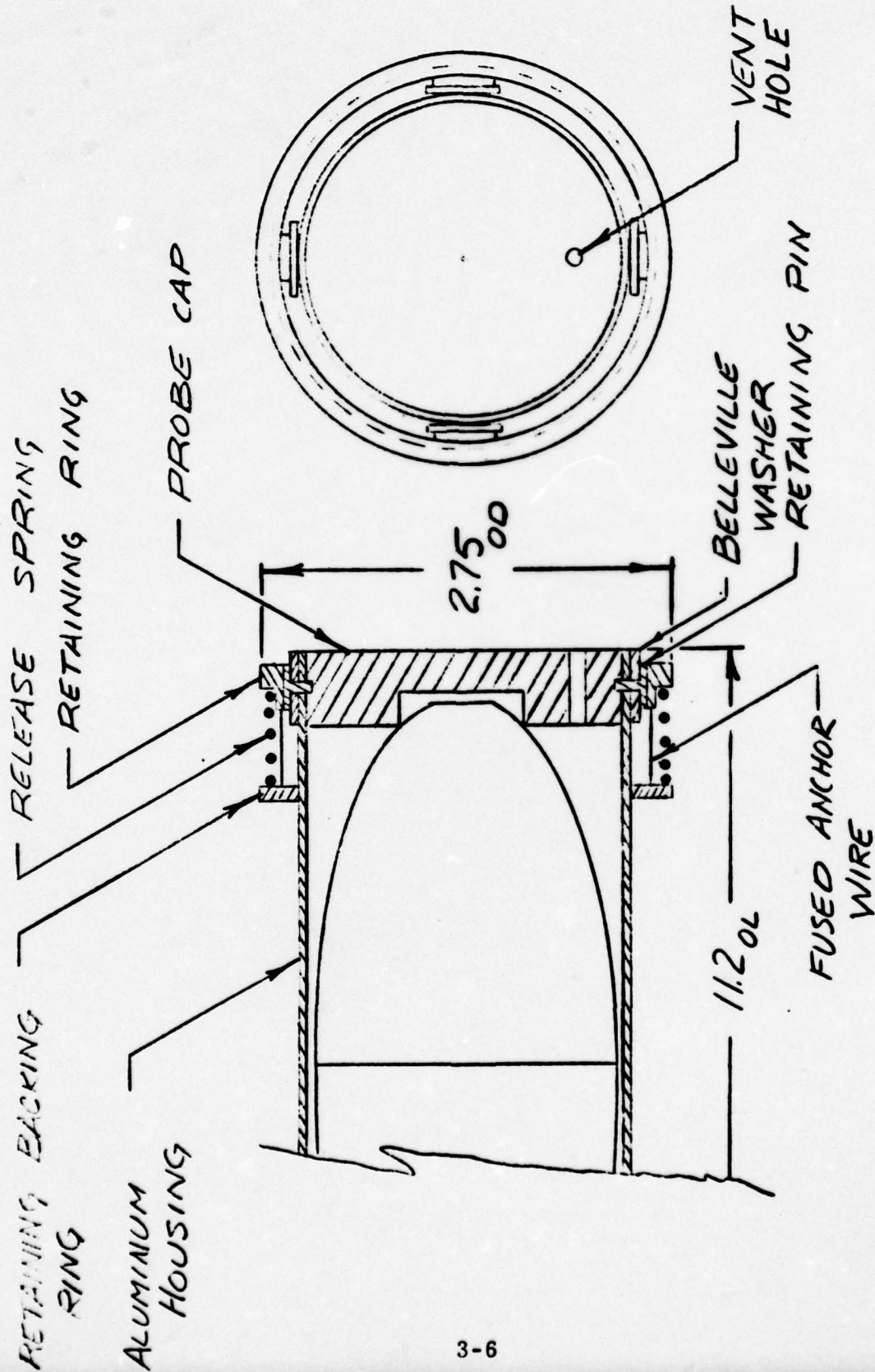
AXBT/EA PACKAGING CONCEPT

Figure 3-1



T-7 RELEASED FROM ANBT/EA

Figure 3-2



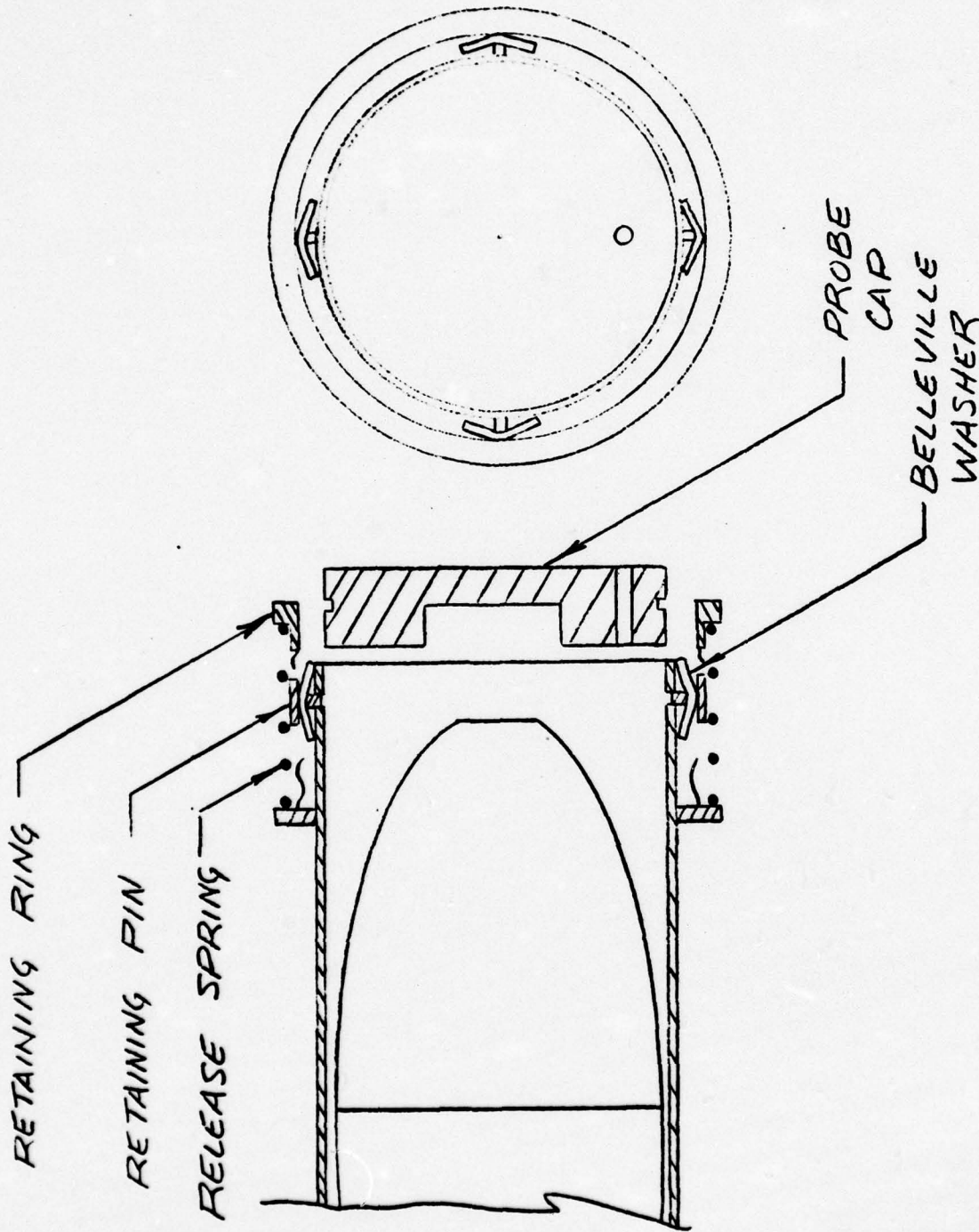
AXBT/EA PACKAGING CONCEPT (ALTERNATE RELEASE)

Figure 3-3

springs are held in the locked position, protruding into a groove in the probe cap, by the retaining ring. The retaining ring is spring-loaded to the release position by the release spring and backing ring but held in the locked position by the fused anchor wire.

When the fuse anchor wire is broken (see Fig. 3-4), the retaining ring is forced to the release position by the release spring. This frees the retaining pins which are then retracted by the Belleville washers, releasing the probe cap. The T-7 probe is then free to exit the housing and begin its descent.

Figure 3-5 shows the position of the AXBT/EA in an AXBT.



T-7 RELEASED FROM AXBT/EA (ALTERNATE RELEASE)

Figure 3-4

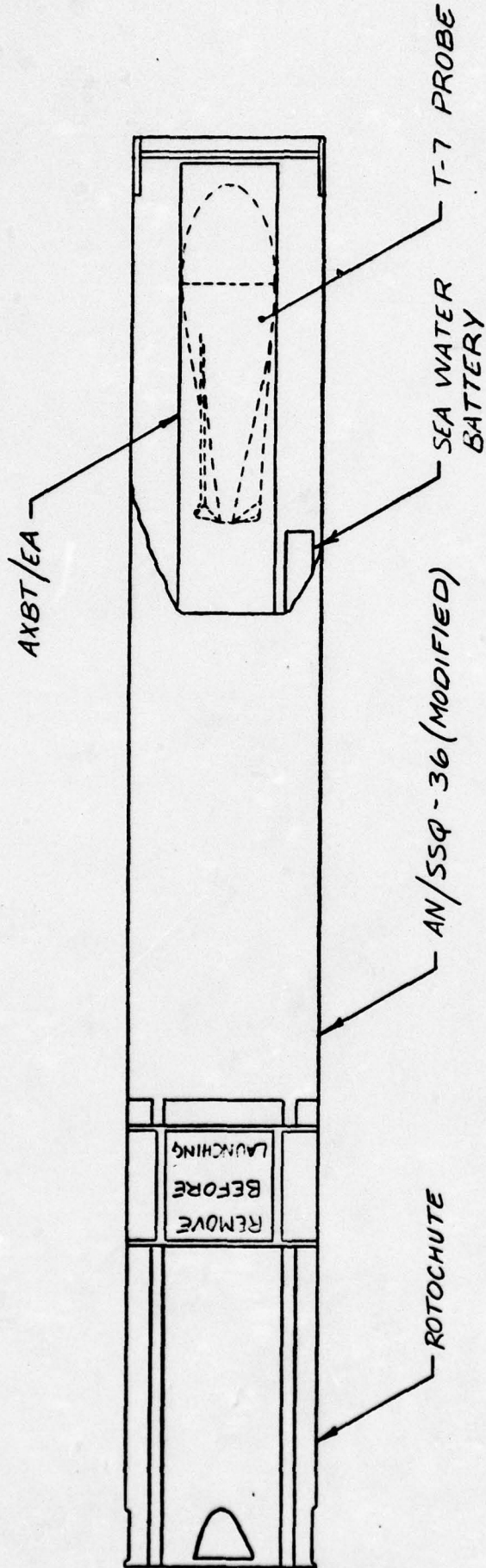


Figure 3-5

#### 4.0 ELECTRICAL DESIGN

##### 4.1 General

Early in pre-electrical design reviews for the feasibility study, it was determined by Sippican that a new approach was required to electrically interface a T-7 probe to an AN/SSQ-36 Sonobuoy if improved performance and accuracy were to be realized.

In March of 1975 Sippican had established a unique concept for a temperature-to-frequency converter which would self calibrate using phase-locked loop techniques that would limit accuracy-determining elements to two or three passive components. Because of the extreme operating temperature range and long shelf-life requirement for an improved 36 Sonobuoy, it was decided that we should attempt to reduce this self-calibrating concept to practice in the feasibility study. Since the goal of this study was to determine feasibility, breadboard component costs were not given primary consideration and conservative design constraints were used to insure satisfactory performance. However, the self-calibrating design concept was aimed toward production hardware. Preliminary circuit design and breadboard fabrication were completed in February 1976 utilizing the self-calibrating at buoy water entry technique. Two breadboards of the circuit were made for test evaluation; one with precision Vishay S102 resistors

(.01%) which was subsequently supplied to NADC for temperature testing August 19, 1976, and the other with standard RN55D resistors (1%) in the DC bridge portion of the circuit.

#### 4.2 Circuit Design

##### Concept

The basic concept of this system uses phase-locked loop techniques, where the D. C. measuring bridge and a voltage-controlled oscillator (VCO) are calibrated at two points, representing offset and gain of the system to a quartz crystal controlled oscillator and two internal calibration resistors.

##### Thermistor Bridge and Voltage Controlled Oscillator (Fig. 4-1)

The Sippican Bridge II D. C. Thermistor Measuring Bridge is utilized in the normal manner where its output is zero VDC at the low temperature end of its range and typically 10 VDC at the high temperature end of its range. It is supplied with a nominal reference voltage ( $E_{Ref}$ ) of 3.2 VDC from a reference source and amplifier A-2. The first order errors in the bridge circuit for the relationship of thermistor probe resistance/bridge output voltage are mainly operation amplifier DC characteristics, aging, component tolerance, reference voltage, and their related temperature coefficients. At the low temperature end of its range, the reference voltage term is cancelled out and removed as a first order source of error.

The output voltage of the bridge is inverted and scaled in operational amplifier A-1 to establish the voltage-to-frequency gain factor of the system for the given nominal value of  $E_{Ref}$  supplied to the bridge. Provision is made in amplifiers A-1 and A-2 for controlling their output voltage which in effect varies the offset voltage in A-1 and  $E_{Ref}$  supplied to the bridge in A-2. It should be pointed out that by varying  $E_{Ref}$ , the effective gain of the system is varied. If a resistance equal to the thermistor probe at the low temperature end of the bridge range is terminated at the bridge input, the VCO nominal frequency can be adjusted by the offset voltage control of A-1. If a resistance equal to the thermistor probe at the high temperature end of the bridge range is terminated at the bridge input, the VCO nominal frequency can be adjusted by the  $E_{Ref}$  voltage control of A-2. Therefore, by adjusting these two control voltages, a means of calibrating the VCO frequency for a specified bridge input resistance has been established which includes the bridge circuit errors and VCO gain sensitivity errors.

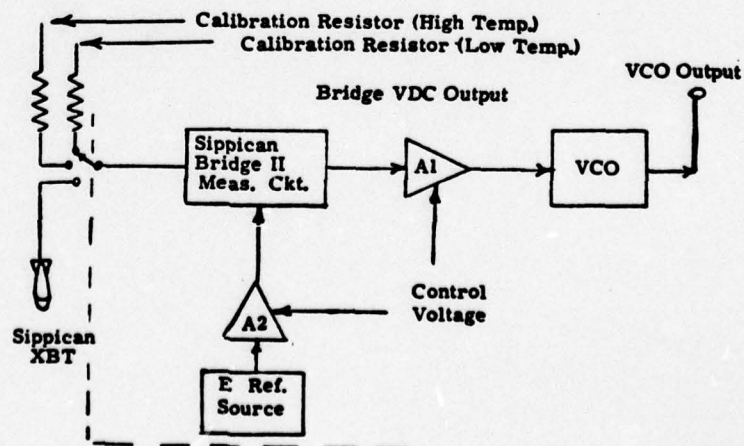


Figure 4-1 Thermistor Bridge &amp; VCO

Phase-Locked Loop (Fig. 4-2)

The VCO, in addition to providing the system output, drives the X input of a frequency comparator circuit using a four-quadrant analog multiplier. The Y input of the frequency comparator is connected to a programmable divider which is driven from a quartz crystal oscillator. This permits comparison of the X input from the VCO to one of two frequencies originating from the crystal oscillator. The output of the frequency comparator is integrated, amplified, and buffered and represents an analog control voltage which is proportional to the frequency-phase relationship of the X-Y voltages at the input. By selectively feeding this control voltage back to the control inputs of A-1 or A-2, a phase-locked loop is established consisting of the bridge input resistance, bridge circuit,  $E_{Ref}$ , amplifiers A-1, A-2, and the VCO. As stated previously, if the input of the bridge is terminated with a calibration resistor equal to the low temperature end of its range, the input to A-1 will be zero VDC  $\pm$  an error voltage resulting from bridge components. If we likewise drive the Y input of the frequency comparator at a frequency equal to the desired VCO output frequency and connect the comparator output control voltage to the A-1 control input, then the resulting phase-locked loop will cause the control voltage applied to A-1 to shift in a way that will lock the VCO at the same frequency applied to the Y input of the comparator. If we likewise drive the Y input of the

comparator at a frequency equal to the desired VCO output frequency at the high temperature end of the bridge range, terminate the input with a high temperature calibration resistor, and connect the comparator output control voltage to the A-2 control input, then the resulting phase-locked loop will cause the control voltage summed at A-2 to shift in a way that will lock the VCO at the same frequency applied to the Y input of the comparator. The gain and time constant of the phase-locked loop is designed so that the capture frequency range is always greater than the maximum accumulative error of the VCO nominal frequency at the low and high temperature calibration points.

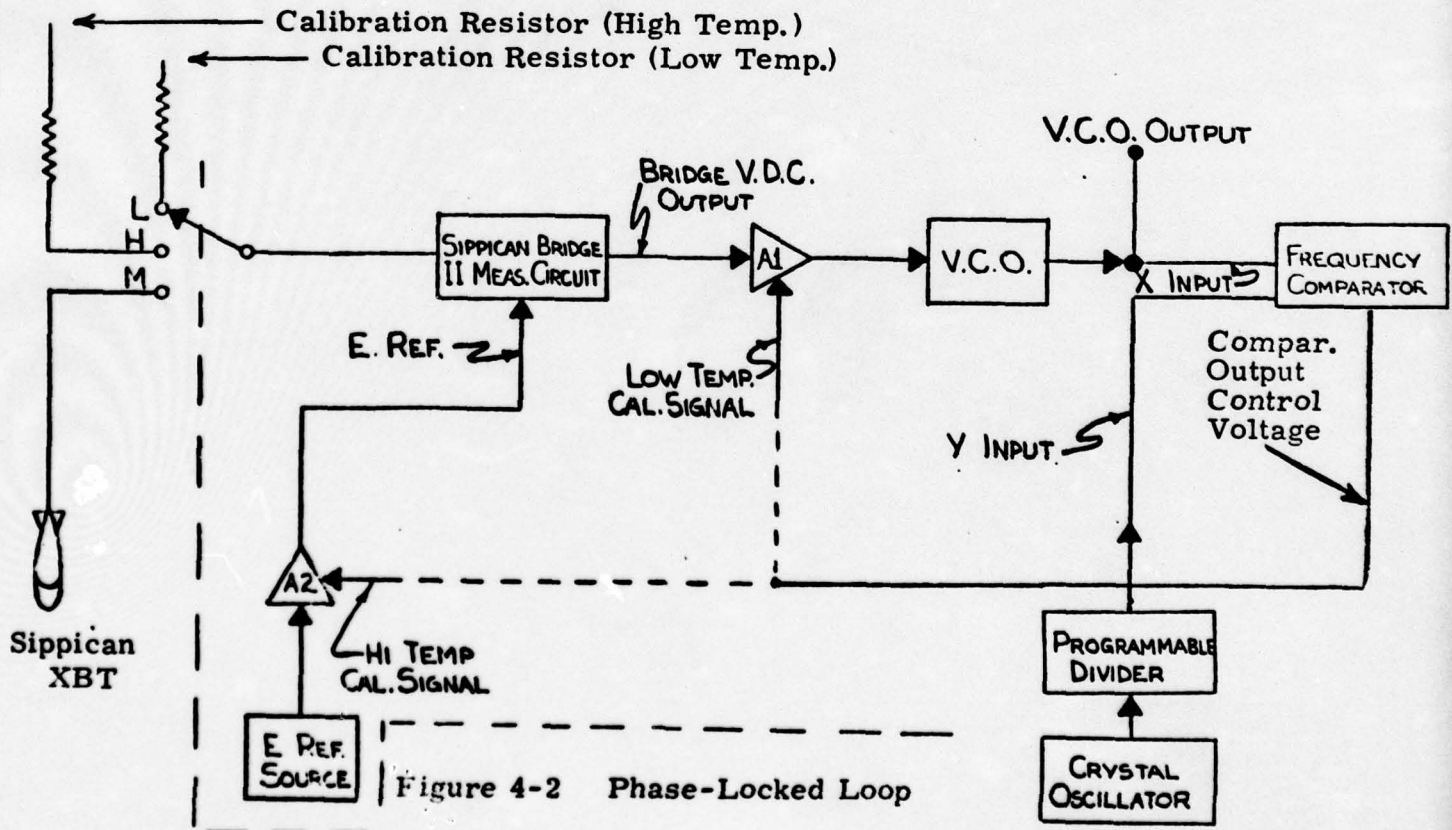


Figure 4-2 Phase-Locked Loop

Sample and Hold with Switching (Fig. 4-3)

We have shown how it is possible to calibrate the bridge input resistance to the VCO output frequency in a two-step operation typical of offset and gain calibration procedures. In order to hold the calibration at each point while the other point is calibrated, it is necessary to use some form of analog memory for the control voltage from the frequency comparator. Additionally, switching is required to switch the control voltage to either A-1 or A-2. These functions are best performed in two individual sample and hold circuits, one for the A-1 input and the other for the A-2 input. The sample and hold circuits are designed for extremely low leakage current (10 pA) so that low capacity memory capacitors can be utilized with memory retention upwards of one-half hour. Additionally, special consideration must be given to the sample mode time constant in order to preserve the capture frequency range of the phase-locked loop.

It is desirable when possible to choose the low and high temperature calibration frequencies so that the crystal oscillator frequency can be a common multiple. This permits the use of a single crystal oscillator. A programmable divider follows the crystal oscillator to select the correct calibration frequency. By using appropriate logic for switching the bridge input, control voltage sample and hold circuits, and the programmable divider, a sequence of low and high temperature calibration, one or more

times, followed by bridge input termination to the thermistor probe is established.

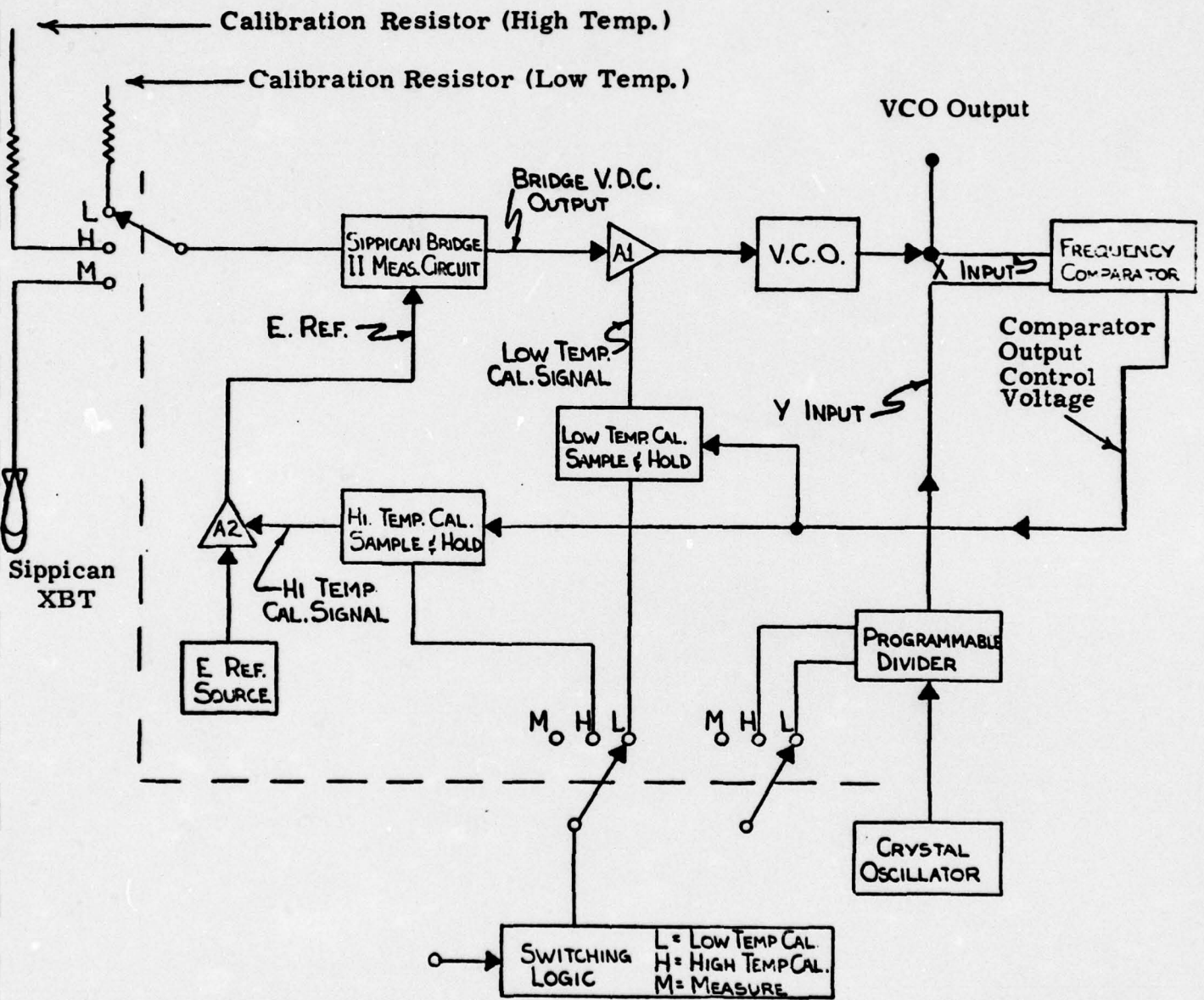


Figure 4-3 Temperature to Frequency Measuring System

The calibration sequence for the AXBT Breadboard is shown in Fig. 4-4. It consists of the following:

1. Switch to run.
2. Sample and hold low temperature calibration.
3. Sample and hold high temperature calibration.
4. Repeat of 2 and 3.
5. Switch bridge input to the XBT thermistor probe.

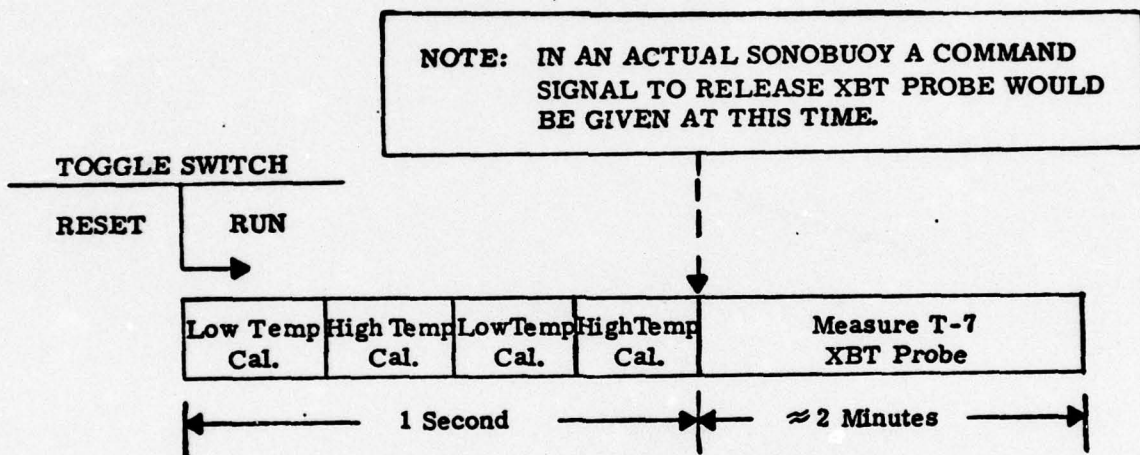


Figure 4-4 Calibration Sequence

The acquisition time of the sample-hold circuits is limited principally by the charging time constant of the memory capacitors. This is typically 100 milliseconds. The switching of the bridge input between calibration resistors and the XBT thermistor probe is accomplished with low  $R_{DS(on)} \approx 3\Omega$  field-effect transistors.

The system logic, which consists of COS/MOS integrated circuits, can be made somewhat flexible. In the breadboard, for example, a toggle switch initiates a start signal for the mode sequencing as shown in Fig. 4-4. The calibrating signal is included in the output signal to the RF transmitter which we feel is desirable. This provides for a calibration reference further downstream for the system user, which may be used either as a correction factor or automatic system calibration.

A supply voltage of  $\pm 15$  VDC was chosen for the breadboard as a matter of convenience. The total load is  $\approx 900$  milliwatts. The design is capable of being made to operate with other power supply combinations as long as they are bipolar with reference to seawater ground. Regulation is not critical with  $\pm 15\%$  being acceptable.

## 5.0 BREADBOARD TEST

5.1 Summary

Results of breadboard performance testing indicate the following capabilities:

Electronics Ambient Temperature

- o Deviation including VCO nonlinearity less than  $\pm 0.073$  degrees celcius over an ambient temperature range of  $+50^{\circ}\text{C}$  to  $-40^{\circ}\text{C}$ .

Linearity

- o Uncorrected (S-Curve),  $-0.451^{\circ}\text{C}$ ,  $+0.455^{\circ}\text{C}$
- o Corrected to the expression:

$$\text{Frequency} = \left( \frac{1.39234 \times 10^5}{R_{\text{TH}} + 5607} - 5.82203 \right) (135) + 1350$$
$$= +0.056^{\circ}\text{C}$$

Drift

- o Accuracy change 2 minutes after self-calibrating sequence less than  $\pm 0.002^{\circ}\text{C}$ .

Supply Voltage Variation

- o Deviation for a supply voltage of  $15 \pm 2$  VDC equals  $\pm 0.014^{\circ}\text{C}$ .

Response

- o 2 millisecond, 63% response to a step change in AXBT input current.

System Test

- o No discernible difference between recorder trace made from XBT trace simulator on a Sippican MK2A shipboard recorder and recorder trace made in P3C mockup test.

As indicated in the test results, the self-calibrating temperature measuring system offers an approach which, interfaced with the Sippican T-7 XBT probe, is capable of meeting the requirements of an improved AN/SSQ-36 Sonobuoy. The design goal for an AXBT with the accuracy of the present Sippican shipboard system of  $\pm 0.2^{\circ}\text{C}$  is easily surpassed. With power supply variations of  $\pm 13\%$  affecting accuracy by  $\pm 0.014^{\circ}\text{C}$ , power source requirements can be very flexible as to regulation.

The system test, though somewhat subjective, indicated the ability to duplicate very precisely the same temperature profile through the RF link as was obtained with the direct wire link.

## 5.2 General

To verify design goals, Sippican performed tests at its Marion Massachusetts facility on the AXBT/Electrical Assembly. Laboratory type equipment was used throughout the test program. For the system test a

special XBT temperature profile simulator (XBTS) was used. This device consists of a motor-driven cam and lever connected to a potentiometer which enables us to generate a repeatable time varying electrical signal equivalent to an XBT being deployed in the ocean.

### 5.3 Test Results

#### Electronics Ambient Temperature

- o The AXBT breadboard, using 1% RN55D resistors in the bridge circuit, was sealed in a temperature chamber and connected to an external resistor decade box, frequency counter, and power supply. With a thermocouple monitoring the inside chamber temperature, the breadboard was allowed to stabilize at 50, 25, -1, -20, and -40 degrees celsius while input and output data were recorded. To obtain data for system linearity, increments of 2 degrees celsius were used for the AXBT input temperatures.

At each resistance setting of the decade box (AXBT input temperature), the calibration sequence was initiated and the output frequency recorded at the end of a two-minute period. The resulting input temperature, output frequency, and indicated temperature is

shown in Tables 5-1 through 5-5 for each of the five ambient test temperatures. To allow for the thermistor "S" curve, indicated temperatures are corrected to the expression:

$$\text{Frequency} = \left( \frac{1.39234 \times 10^5}{R_{TH} + 5607} - 5.82203 \right) (135) + 1350$$

#### Linearity

Using data recorded in the accuracy vs. electronics ambient temperature test, indicated temperatures were calculated for the uncorrected (S-curve) nonlinearity. Maximum deviations occurred at 6°C and 28°C. The deviation was -0.451°C and +0.455°C, respectively.

Using the same data base corrected by the expression:

$$\text{Frequency} = \left( \frac{1.39234 \times 10^5}{R_{TH} + 5607} - 5.82203 \right) (135) + 1350 \text{ the}$$

maximum deviation occurred at 16°C and was +0.056°C.

#### Drift

The AXBT breadboard was connected to a resistor decade box and the frequency output connected to a frequency counter. The resistor decade box was adjusted to the equivalents of -1, 6, 18, 28 and 35°C. At each temperature the calibration cycle was initiated ( $T_0$ ). The output frequency was recorded for  $T_0$ . The worst case accuracy change was measured for  $T_0 - T_2$  minutes and found to be  $\pm 0.002$  degrees celcius.

TABLE 5-1 Electronics Ambient Temperature (50° C) Test

AXBT Input Temp. °C	Indicated Temp. °C	Deviation °C	Indicated Frequency Hz
-2.22	-2.237	-.017	1349.4
0	-0.003	-.003	1420.8
2	2.008	.008	1487.6
4	4.020	.020	1556.6
6	6.028	.028	1627.5
8	8.036	.036	1700.0
10	10.045	.045	1774.0
12	12.045	.045	1848.7
14	14.048	.048	1924.2
16	16.050	.050	2000.0
18	18.050	.050	2075.8
20	20.048	.048	2151.4
22	22.045	.045	2226.4
24	24.042	.042	2300.8
26	26.036	.036	2374.1
28	28.031	.031	2446.1
30	30.022	.022	2516.5
32	32.017	.017	2584.9
34	34.008	.008	2651.4
35.55	35.553	.003	2700.1

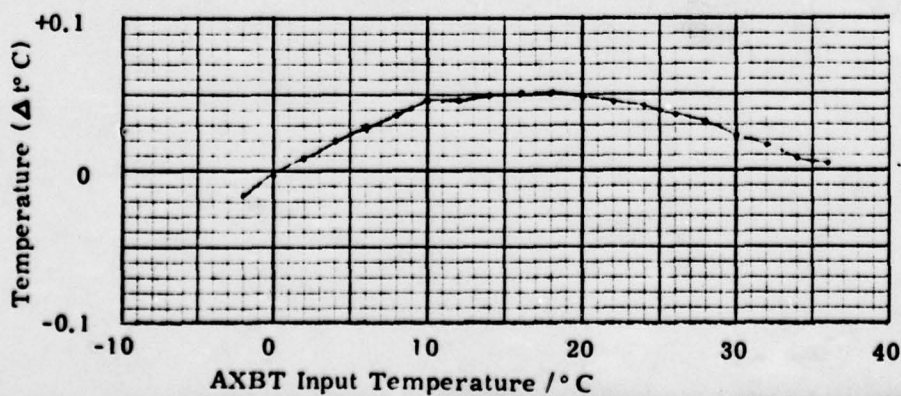


TABLE 5-2 Electronics Ambient Temperature (25° C) Test

AXBT Input Temp. °C	Indicated Temp. °C	Deviation °C	Indicated Frequency Hz
-2.22	-2.22	0.0	1350.0
0	0.008	.008	1421.2
2	2.017	.017	1487.9
4	4.025	.025	1556.8
6	6.034	.034	1627.7
8	8.042	.042	1700.2
10	10.050	.050	1774.2
12	12.050	.050	1848.9
14	14.053	.053	1924.4
16	16.056	.056	2000.2
18	18.053	.053	2075.9
20	20.050	.050	2151.5
22	22.050	.050	2226.6
24	24.048	.048	2300.9
26	26.042	.042	2374.3
28	28.039	.039	2446.4
30	30.036	.036	2516.9
32	32.028	.028	2585.3
34	34.020	.020	2651.8
35.55	35.561	.011	2700.4

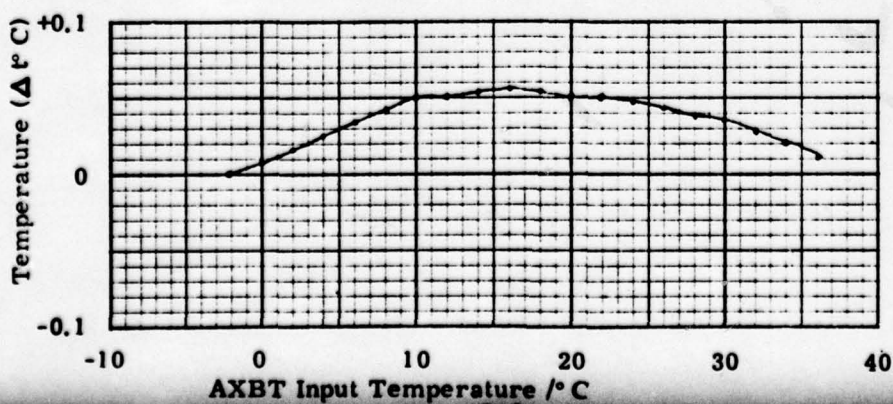


TABLE 5-3 Electronics Ambient Temperature (-1° C) Test

AXBT Input Temp. °C	Indicated Temp. °C	Deviation °C	Indicated Frequency Hz
-2.22	-2.228	-.008	1349.7
0	0.003	.003	1421.0
2	2.011	.011	1487.7
4	4.020	.020	1556.6
6	6.028	.028	1627.5
8	8.036	.036	1700.0
10	10.045	.045	1774.0
12	12.048	.048	1848.8
14	14.053	.053	1924.4
16	16.056	.056	2000.2
18	18.053	.053	2075.9
20	20.050	.050	2151.5
22	22.050	.050	2226.6
24	24.050	.050	2301.1
26	26.046	.046	2374.5
28	28.045	.045	2446.6
30	30.039	.039	2517.1
32	32.039	.039	2585.7
34	34.034	.034	2652.3
35.55	35.578	.028	2701.0

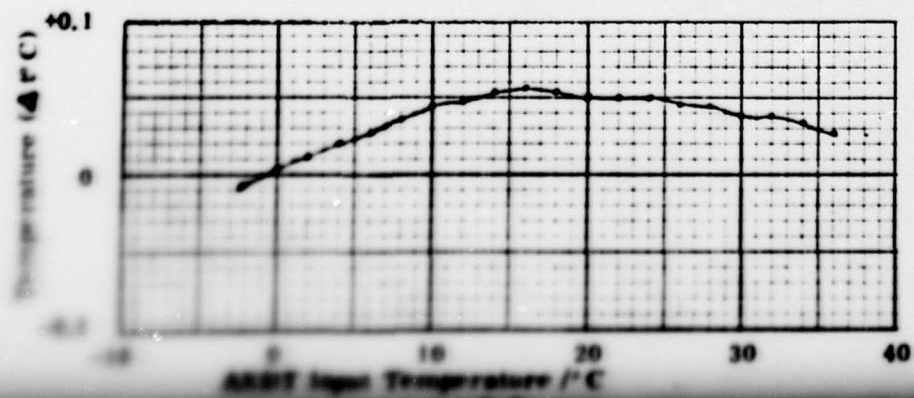


TABLE 5-4 Electronics Ambient Temperature ( $\pm 20^{\circ}\text{C}$ ) Test

AXBT Input Temp. $^{\circ}\text{C}$	Indicated Temp. $^{\circ}\text{C}$	Deviation $^{\circ}\text{C}$	Indicated Frequency Hz
-2.22	-2.234	-.014	1349.5
0	-0.003	-.003	1420.8
2	2.006	.006	1487.5
4	4.014	.014	1556.4
6	6.022	.022	1627.3
8	8.031	.031	1699.8
10	10.036	.036	1773.7
12	12.039	.039	1848.5
14	14.045	.045	1924.1
16	16.050	.050	2000.0
18	18.050	.050	2075.8
20	20.050	.053	2151.6
22	22.053	.053	2226.7
24	24.053	.053	2301.2
26	26.053	.053	2374.7
28	28.048	.048	2446.7
30	30.045	.045	2517.3
32	32.045	.045	2585.9
34	34.042	.042	2652.6
35.55	35.586	.036	2701.3

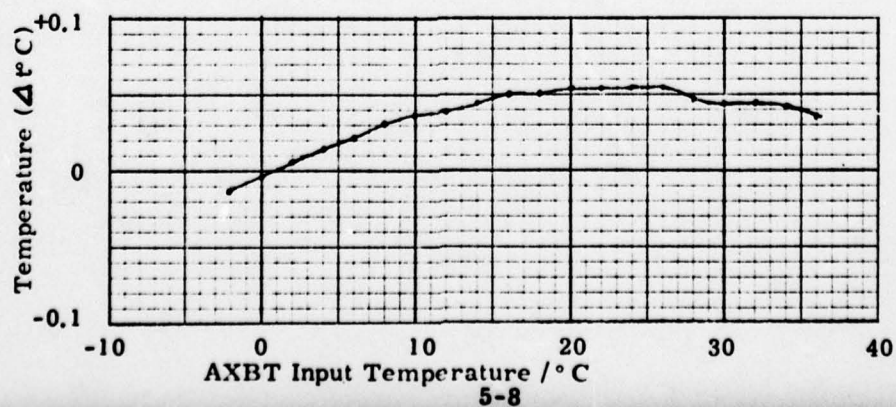
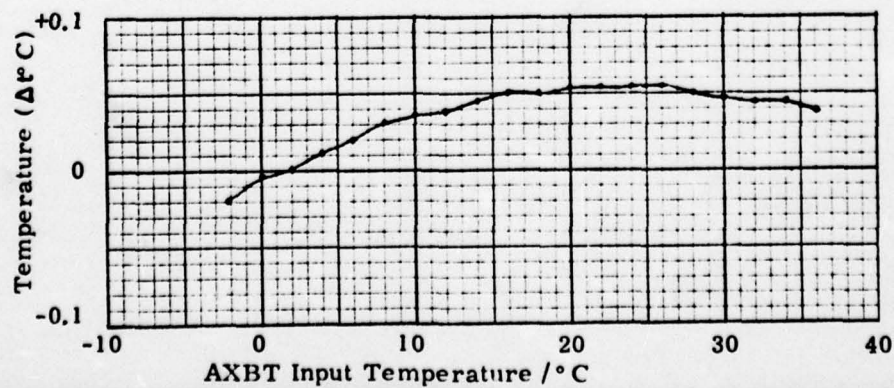


TABLE 5-5 Electronics Ambient Temperature (-40° C) Test

AXBT Input Temp. °C	Indicated Temp. °C	Deviation °C	Indicated Frequency Hz
-2.22	-2.240	-.020	1349.3
0	-0.008	-.008	1420.6
2	2.0	0.0	1487.3
4	4.011	.011	1556.3
6	6.020	.020	1627.2
8	8.031	.031	1699.8
10	10.036	.036	1773.7
12	12.039	.039	1848.5
14	14.045	.045	1924.1
16	16.050	.050	2000.0
18	18.050	.050	2075.8
20	20.053	.053	2151.6
22	22.053	.053	2226.7
24	24.053	.053	2301.2
26	26.053	.053	2374.7
28	28.050	.050	2446.8
30	30.048	.048	2517.4
32	32.045	.045	2585.9
34	34.045	.045	2652.7
35.55	35.589	.039	2701.4



Supply Voltage Variation

The input of the AXBT breadboard was connected to a resistor decade box and the frequency output connected to a frequency counter. With the breadboard supply voltage adjusted to +15 VDC and -15 VDC the calibration cycle was initiated. The output frequency was recorded for input temperature equivalents of 0, 17, and 35°C.

The breadboard supply voltage was then adjusted to +17 VDC and -17 VDC and the frequency recorded for the same input conditions. The breadboard supply voltage was then adjusted to +13 VDC and -13 VDC and the output frequency recorded for the same input conditions.

Table 5-6 indicates the resulting output frequency and temperature equivalent for the three supply voltage conditions.

SUPPLY ±15 VDC Input Temp. °C	Output Frequency, Hz	Deviation °C	Output Temp. °C
0 (16329Ω)	1421.1		0.006
17 ( 7161Ω)	2038.1		17.053
35 ( 3263Ω)	2683.6		35.014
SUPPLY ±17 VDC			
0	1420.9	-0.006	0.0
17	2037.9	-0.005	17.048
35	2683.4	-0.006	35.008
SUPPLY ±13 VDC			
0	1421.3	+0.005	0.011
17	2038.4	+0.009	17.062
35	2684.1	+0.014	35.028

TABLE 5-6

Response

The response of the breadboard was checked by substituting a pulse generator for the thermistor at the input of the breadboard and converting the breadboard VCO output to DC using a frequency-to-voltage converter (see Figure 5-5).

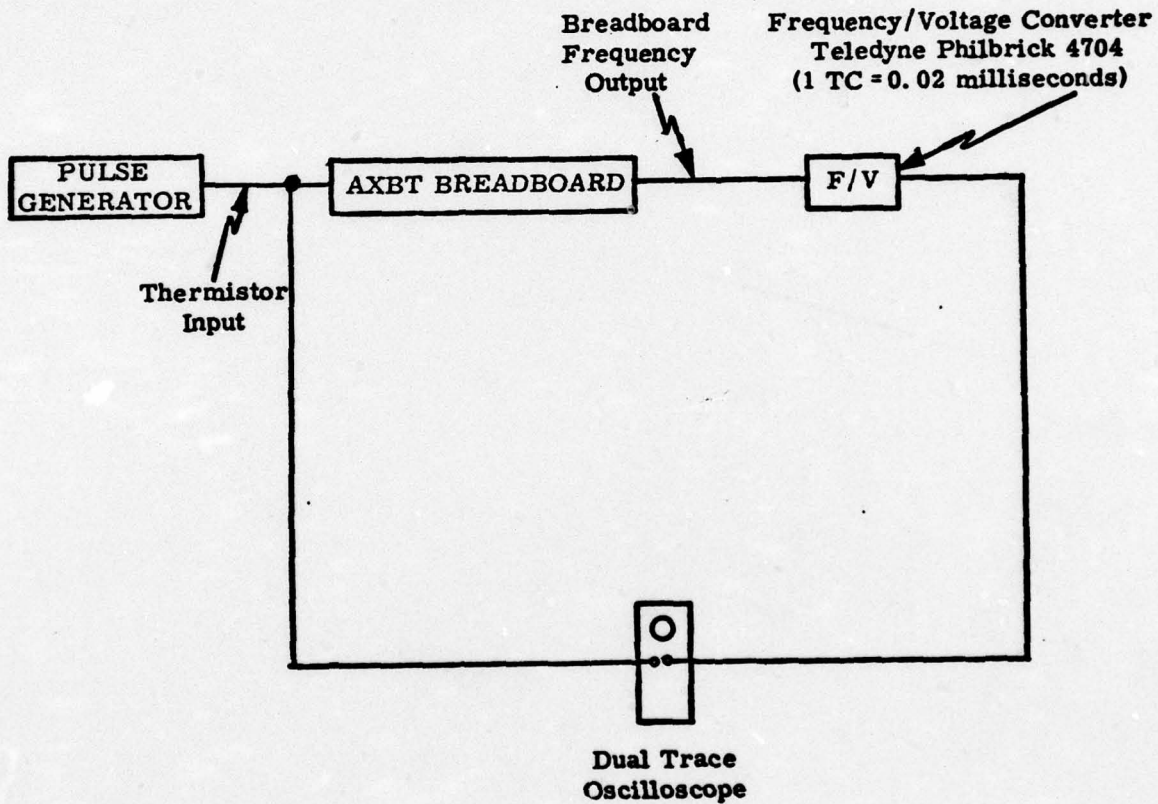
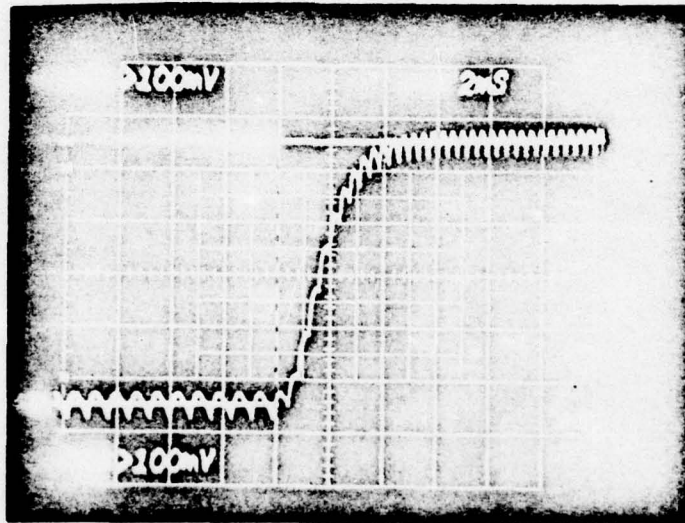


Figure 5-5 Response Test Set-Up

The pulse generator was adjusted to provide a current change equal to the end of scale temperatures of  $-2.22^{\circ}\text{C}$  and  $35.55^{\circ}\text{C}$ . The output of the frequency converter was connected to an oscilloscope. A dual trace was displayed showing the input step from the pulse generator and the DC output of the frequency to voltage converter (Figure 5-6).

One time constant was determined to be two milliseconds maximum for an equivalent temperature step of  $-2.22^{\circ}\text{C}$  to  $35.55^{\circ}\text{C}$ .



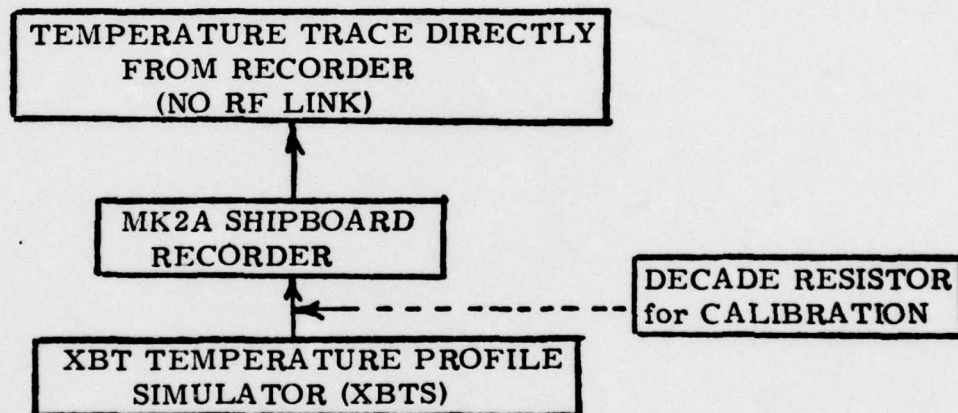
Response

Figure 5-6

System Test

A complete system test was conducted for the purpose of comparing an XBT temperature profile simulator (XBTS) using a standard Sippican MK2A shipboard recorder and the AXBT breadboard through an RF loop to a strip chart recorder (MK2A servo system).

Using the test setup shown in Figure 5-7, a decade resistor box was connected to the MK2A recorder. The strip chart recorder was calibrated at  $-1^{\circ}\text{C}$  and  $35^{\circ}\text{C}$  in accordance with the thermistor R-T table. The recorder was then connected to the XBTS and a temperature profile was made (Figure 5-8).



Sippican MK2-A SHIPBOARD RECORDER TEST SET-UP

Figure 5-7

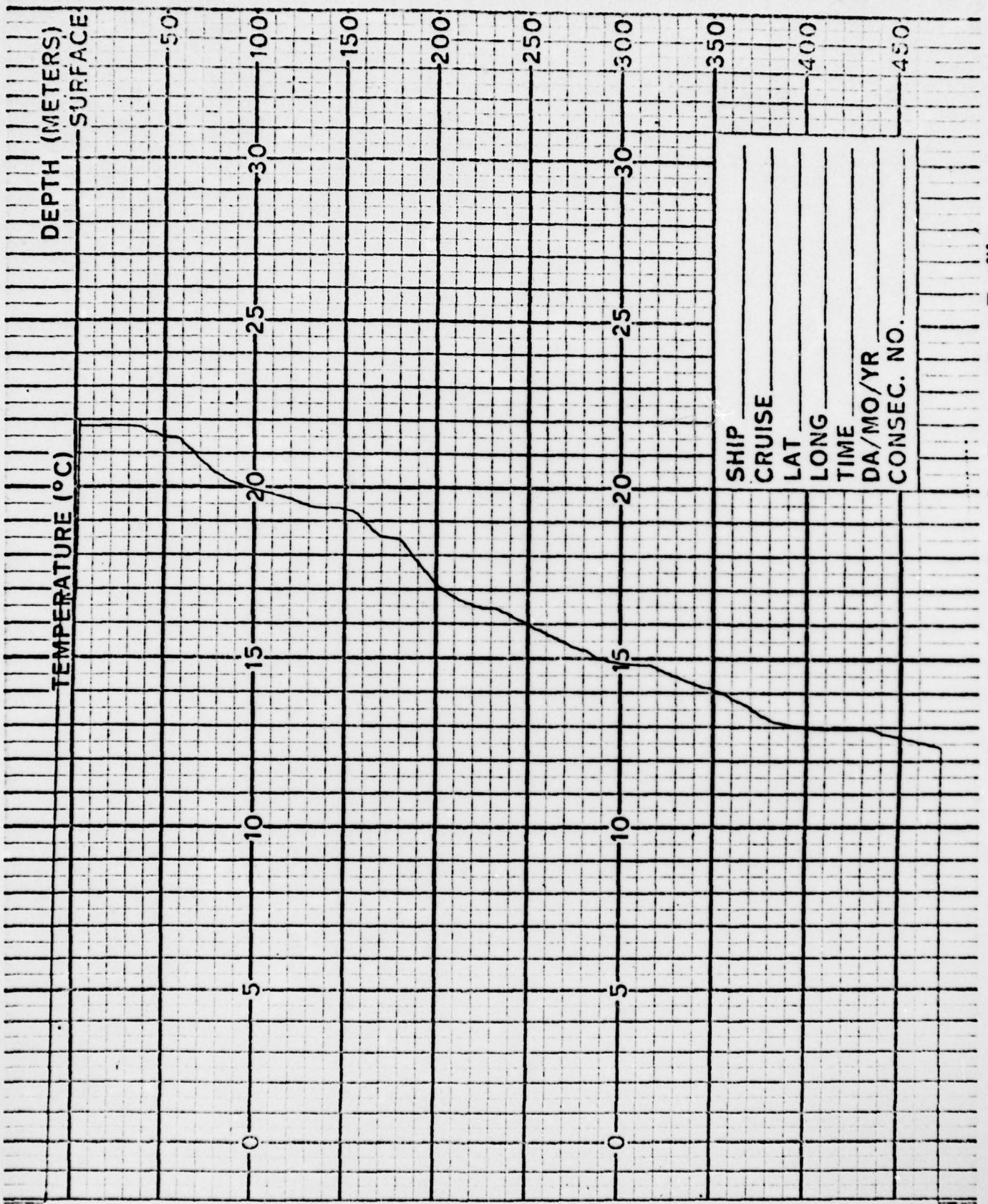
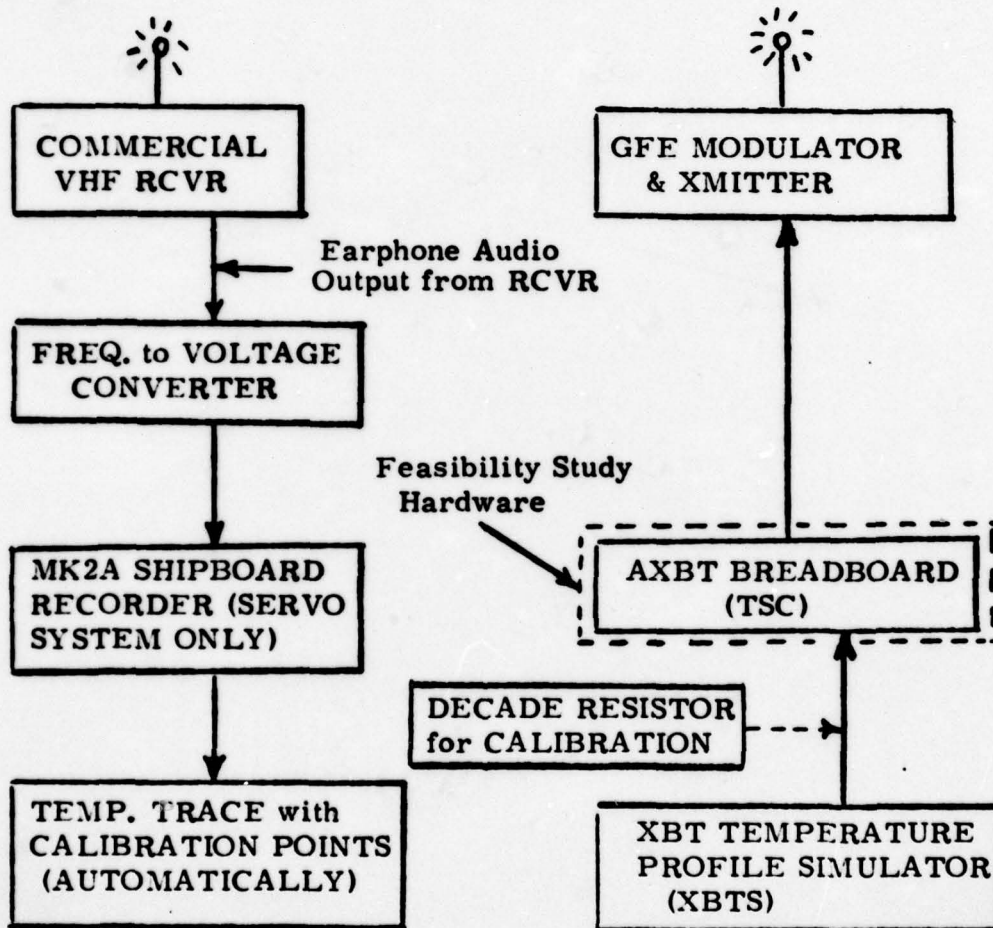


Figure 5-8 Sippican MK-2A Shipboard Recorder Temperature Profile

Using the test set-up shown in Figure 5-9, a decade resistor box was connected to the AXBT breadboard. The strip chart recorder at the end of the RF loop was calibrated at  $-1^{\circ}\text{C}$  and  $35^{\circ}\text{C}$  in accordance with the thermistor R-T table. The AXBT breadboard was connected to the XBTS and a temperature profile was made (Figure 5-10). Comparison was then made between Figures 5-8 and 5-10 for identical temperature profiles.



SIPPICAN AXBT, P-3C MOCKUP TEST SET-UP  
Figure 5-9

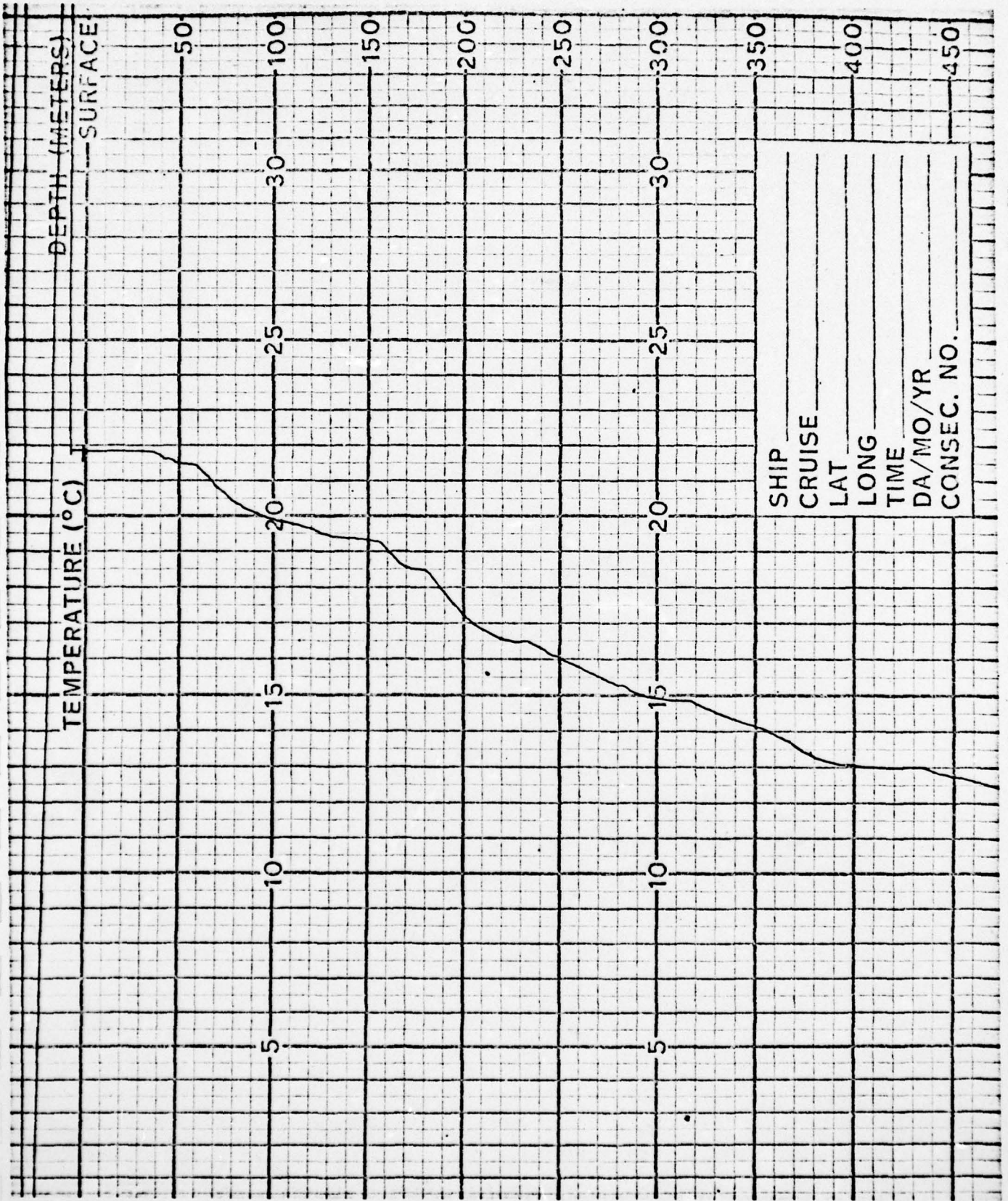


Figure 5-10 Sippican AXBT, P-3C Mockup Recorder Temperature Profile

## 6.0 ERROR ANALYSIS

### 6.1 General

The AXBT/EA as breadboarded was outlined into specific error sources contributing to the overall accuracy of the design. Only those errors which have significance in determining realistic performance of the assembly have been considered in this report.

No consideration is made for the final use of the demodulated receiver signal as an error source.

As there is no frequency offset as a result of going through transmitter modulation to receiver demodulation via the RF link, it is not considered as a source of error.

The greatest single error source is the T-7 XBT probe which Sippican specifies at  $\pm 0.1^\circ\text{C}$ . This has been added to the errors of the electronics in Table 6-2 (page 6-18).

#### Primary Calibrating References

Quartz Crystal

Two Calibration Resistors

DC Bridge Circuit

Resistor Tolerance

T-7 Probe Common-mode Resistance

Common-mode Voltage

Linearity and Offset

Sum of Bridge Errors

Voltage Controlled Oscillator (VCO)

Linearity

Ambient Temperature ChangeThermistor "S" Curve NonlinearityTotal Sum of Errors6.2 Primary Calibrating Reference ErrorsQuartz Crystal

The crystal frequency used in the breadboard is 10.80 KHz which was a readily available stock frequency. This changes the frequency-to-temperature relationship slightly from that specified for the AN/SSQ-36 sonobuoy. For the AXBT breadboard:

$$f = 1429.348689 + 35.7426529t$$

For the relationship:

$$f = 1440 + 36t$$

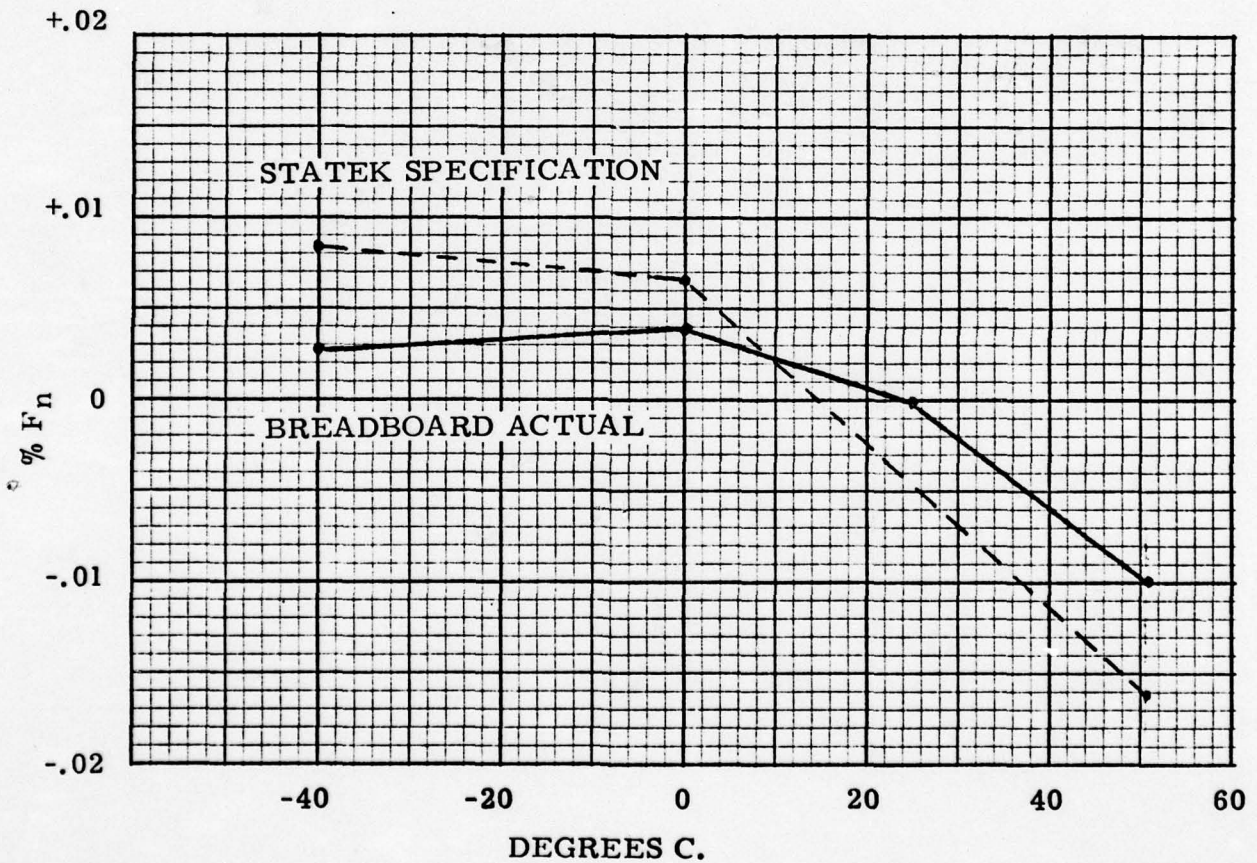
the crystal frequency would be 10.88 KHz.

Deviations for the Statek crystal used in the breadboard are shown in Figure 6-1 along with the Statek specification.

Based on the Statek specification of .024% deviation (-40 to +50°C), the error at the -2.22° calibration point converted to a temperature error is

$(1350 \text{ Hz})(.024\%)(.028^\circ\text{C}/\text{Hz}) = .009^\circ\text{C}$  which can be written  
as  $\pm .0045^\circ\text{C}$  and at the  $35.55^\circ$  calibration point is

$(2700 \text{ Hz})(.024\%)(.028^\circ\text{C}/\text{Hz}) = .018^\circ\text{C}$  which can be written  
as  $\pm .009^\circ\text{C}$ .



STATEK SX-1H CRYSTAL TEMPERATURE COEFFICIENT

$F_n = 10.8 \text{ kHz}$

Figure 6-1

Calibration Resistors

The calibration resistors used in this analysis were  $\pm 0.01\%$   
 $\text{at } 25^\circ\text{C}$ ,  $\pm 5 \text{ PPM}/^\circ\text{C}$ .

The value of the  $35.55^\circ\text{C}$  calibration resistor is  $3193\Omega$ .

The value of the  $-2.22^\circ\text{C}$  calibration resistor is  $18308\Omega$ .

The error contributed is calculated to be as follows for the  
 two sources (tolerance and temperature coefficient):

The contribution of the temperature coefficient is

$$-40^\circ\text{C to } 25^\circ\text{C} = \pm 65^\circ\text{C}(5 \text{ PPM}) = .0325\%$$

$$25^\circ\text{C to } 50^\circ\text{C} = \pm 25^\circ\text{C}(5 \text{ PPM}) = .0125\%$$

These errors can then be R. S. S. 'd with the tolerance to get

$$\sqrt{(-1 \times 10^{-4})^2 + (3.25 \times 10^{-4})^2} = .034\%$$

$$\sqrt{(1 \times 10^{-4})^2 + (1.25 \times 10^{-4})^2} = .016\%$$

At the  $35.55^\circ\text{C}$  calibration point the effect on the  $3193$  resistor converted  
 to a temperature deviation is

$$3193(3.4 \times 10^{-4}) + 3193(1.6 \times 10^{-4}) \Omega \cdot 7.86 \times 10^{-3} \text{ }^\circ\text{C}/\Omega$$

$$= 0.013^\circ\text{C}$$

This can be written as  $\pm 0.0065^\circ\text{C}$  (high temperature calibration error).

AD-A040 226

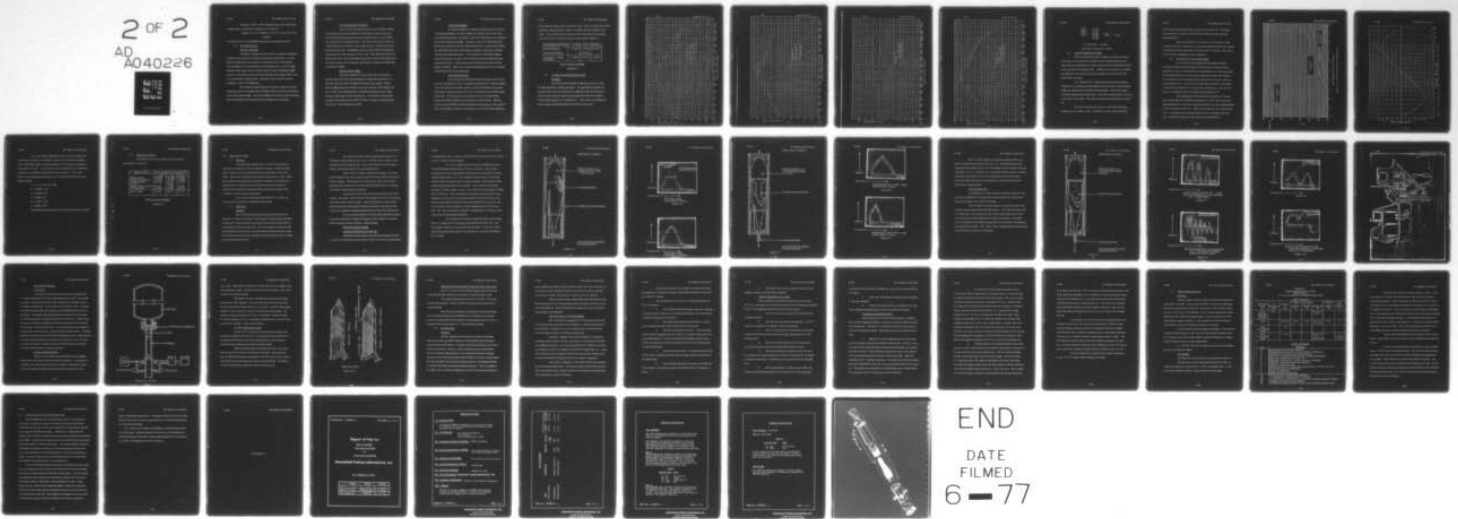
SIPPICAN CORP MARION MASS OCEANOGRAPHIC SYSTEMS DIV F/G 17/1  
FEASIBILITY STUDY: AXBT/EA AIRBORNE EXPENDABLE BATHYTHERMOGRAPH--ETC(U)  
MAY 77 C B TIRRELL, R G WASHBURN, M J BALBONI N00014-76-C-0230

UNCLASSIFIED

R-817

NL

2 OF 2  
AD A040226



END

DATE

FILMED

6-77

Similarly, at the  $-2.22^{\circ}\text{C}$  calibration point, the effect on the  $18308\Omega$  resistor converted to a temperature deviation is

$$18308 (3.4 \times 10^{-4}) + 18308 (1.6 \times 10^{-4}) \Omega \cdot 1.03 \times 10^{-3} \text{ }^{\circ}\text{C}/\Omega \\ = 0.009^{\circ}\text{C}$$

this can be written as  $\pm 0.0045^{\circ}\text{C}$  (low temperature calibration error).

### 6.3 DC Bridge Circuit

#### Resistor Tolerance

The Sippican Bridge II consists of four operational amplifiers and fifteen (15) resistors in multiple closed loop configurations. Its complexity is dictated by the necessity of working with very low thermistor current ( $100\mu\text{a}$ ) to prevent thermistor self-heating errors, a pair of small conductor (#39) magnet wires at approximately  $1\Omega$  per foot totaling  $\approx 3000$  ohms as a transmission line between the thermistor and bridge circuit, and two sea electrodes using seawater, with their various electro-chemical potentials, to close the bridge loop.

The tolerance requirements of the bridge resistors are determined primarily by two bridge input variables and the accuracy requirements of the bridge output voltage. The input variables are common mode resistance (XBT transmission line) and common mode voltage (sea electrodes).

T-7 Common Mode Resistance

The T-7 XBT probe proposed for use in an AXBT sonobuoy would contain approximately 2806 feet (110 grams) of wire on the probe spool and 638 feet (25 grams) on the sea-keeping spool or a total of 3444 feet (135 grams) of transmission line. The wire on the XBT is wound to a weight tolerance of  $\pm 5$  grams, which could result in a transmission line of 3316 feet to 3571 feet. Additionally, the wire used in XBT manufacturing has an ohms-per-foot tolerance of  $0.9\Omega \pm 10\%$ . When these tolerances are added worst case, we find the bridge circuit must retain its specified accuracy with a common mode resistance that could be a minimum of  $2686\Omega$  and a maximum of  $3535\Omega$ .

Common Mode Voltage

Tests were conducted at sea in May 1976 to determine a nominal value of common mode voltage that would exist between the T-7 XBT sea electrode and an AN/SSQ-36 Sonobuoy outer casing. Using a Sippican MK2A Recorder modified to measure common mode voltage, five (5) T-7 XBT's were deployed with an AN/SSQ-36 Sonobuoy outer casing serving as the bridge circuit sea electrode. The average common mode voltage was determined to be 0.448 VDC with a variance of approximately  $\pm 0.05$  VDC. Water salinity was 3.01%.

### Linearity and Offset

To properly analyze the effects of bridge resistor tolerance on linearity and offset, we must consider the bridge as part of the entire self-calibrating system. In essence, when self-calibrating we are adjusting the zero and span of the bridge. Therefore, when self-calibrating with a given set of values for common mode resistance and common mode voltage, the calibration accuracy is determined by changes in these two variables after the self-calibrating cycle. As the tolerance of the bridge resistor network increases, a greater error develops between the calibration and measurement cycle. At the calibration temperature points these errors appear as offsets. Between the calibration temperatures the error appears as both offset and bridge nonlinearity.

### Sum of Bridge Errors

To determine the relationship between bridge resistor tolerance and calibration accuracy, a program was written for a Wang Calculator. Each of the fifteen (15) bridge resistors could be individually varied from its nominal resistance value and the error contribution at the bridge output determined. For the purpose of the program it was assumed that the bridge operational amplifiers had perfect DC characteristics. With the common mode variables specified previously in the program, each resistor value was changed 1% from its nominal value in a direction that would keep

all the indicated output errors of the same sign. This was done at thermistor resistances equal to the low, center, and high temperature inputs of the bridge. The results of the deviation for each of the fifteen (15) resistors was summed R. S. S. (root-sum-square) and is given in Table 6-1.

Thermistor Input Temp.	-2. 22°C	16°C	35. 55°C
Offset Deviation	±0. 028°C	±0. 040°C	±0. 052°C
Linearity Deviation	-	±0. 041°C	-
Total R. S. S. Bridge Deviation	±0. 028°C	±0. 057°C	±0. 052°C

#### SUM OF BRIDGE ERRORS

TABLE 6-1

#### 6. 4 Voltage Controlled Oscillator (VCO)

##### Linearity

The VCO used in the AXBT breadboard is an Exar Type XR-2206 Monolithic Function Generator. To empirically determine the linearity of the VCO, four pieces were subjected to test at 25°C and 0°C. All four pieces showed a peak at the approximate center of the 1360 to 2720 Hz range (Figures 6-2 through 6-5). This peak was averaged and used to express the typical linearity deviation of the device.

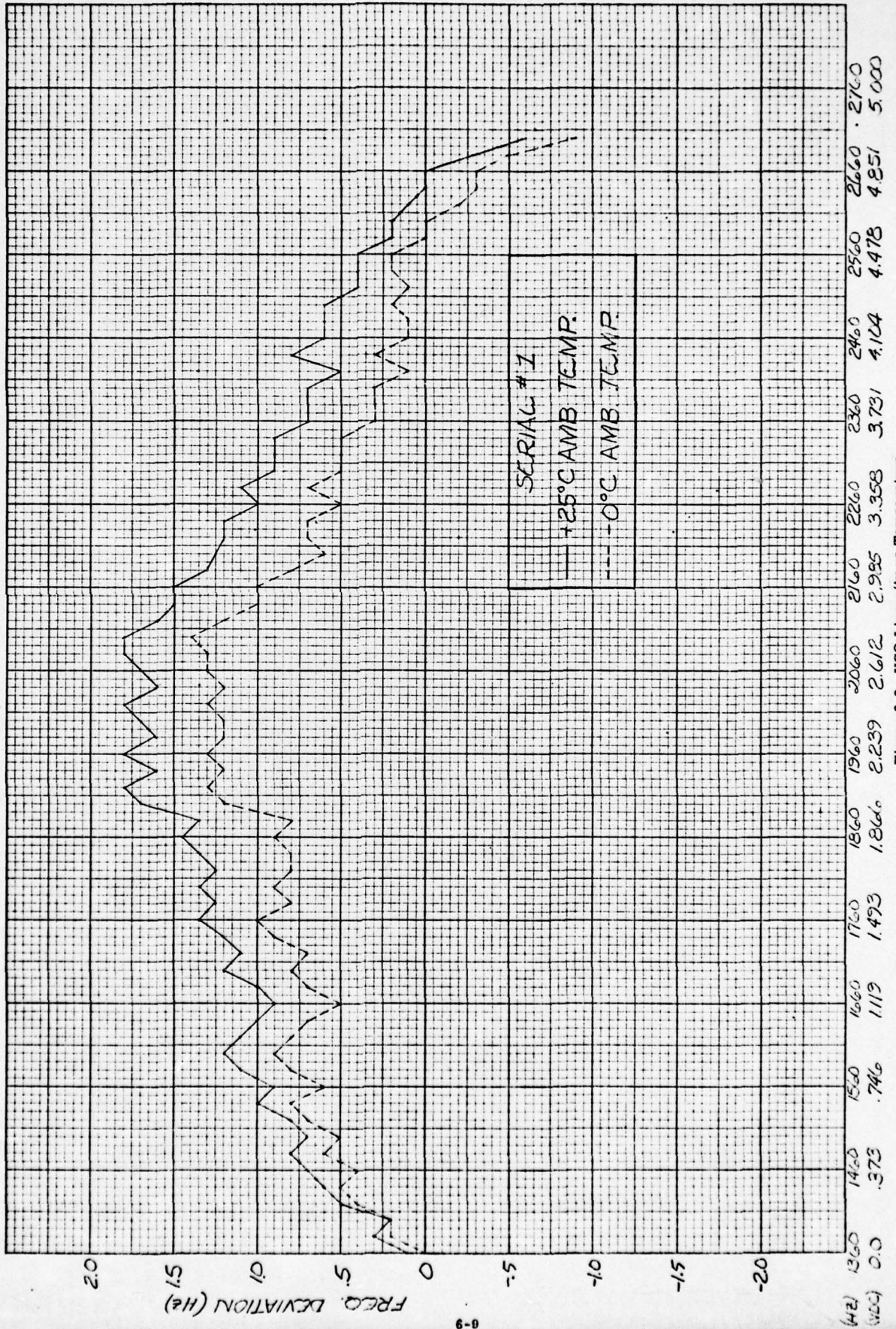
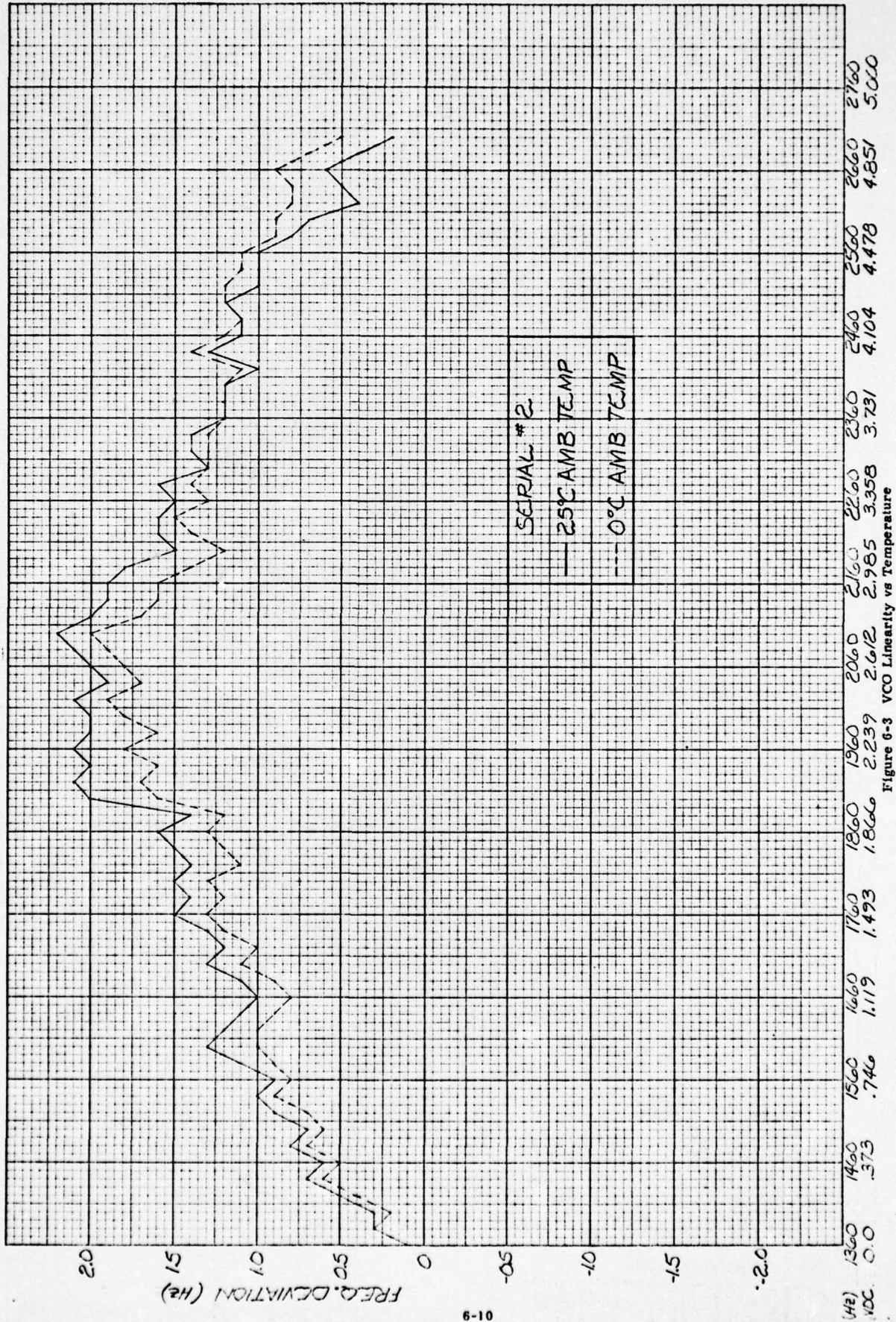


Figure 6-2 VCO Linearity vs Temperature



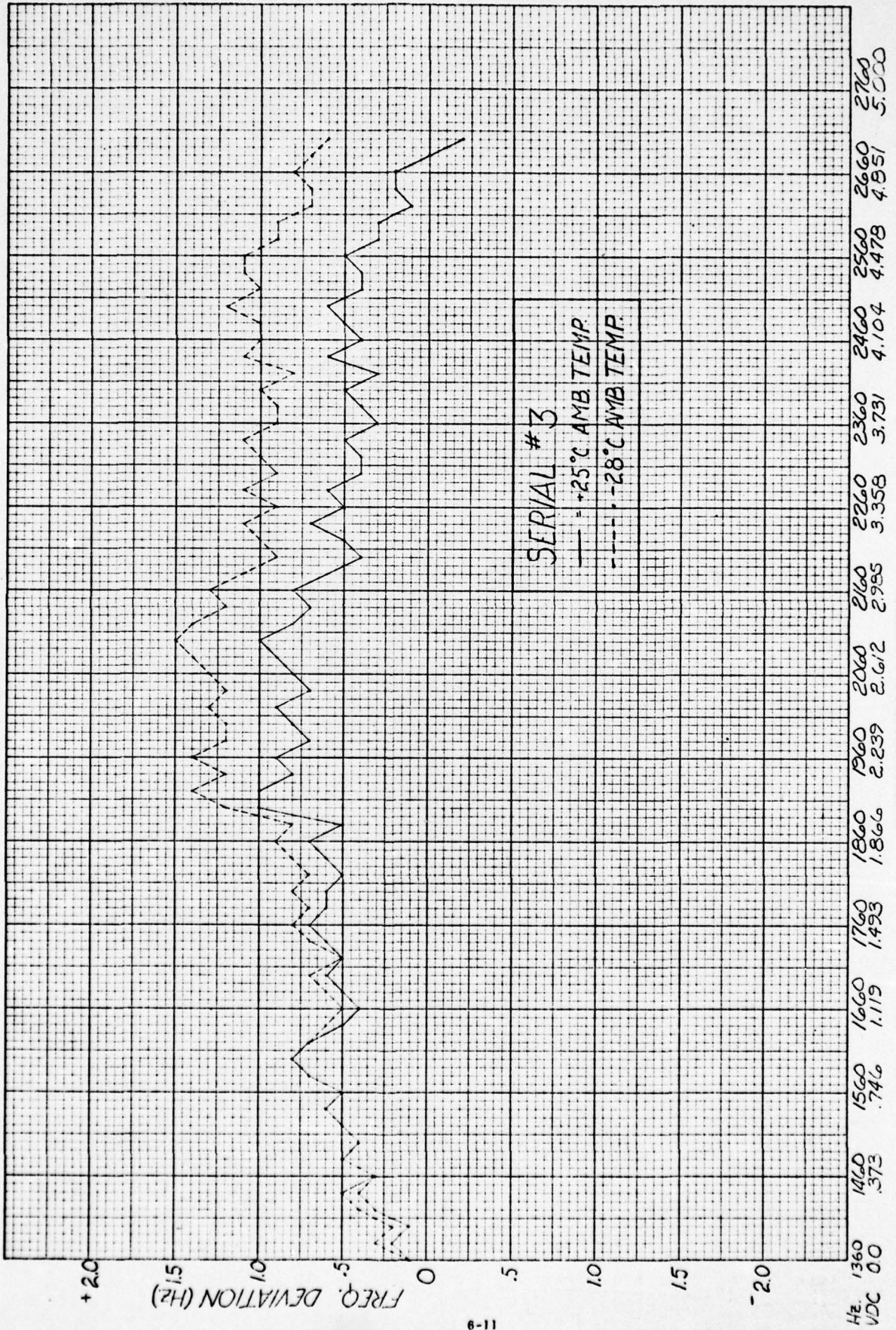


Figure 6-4 VCO Linearity vs Temperature

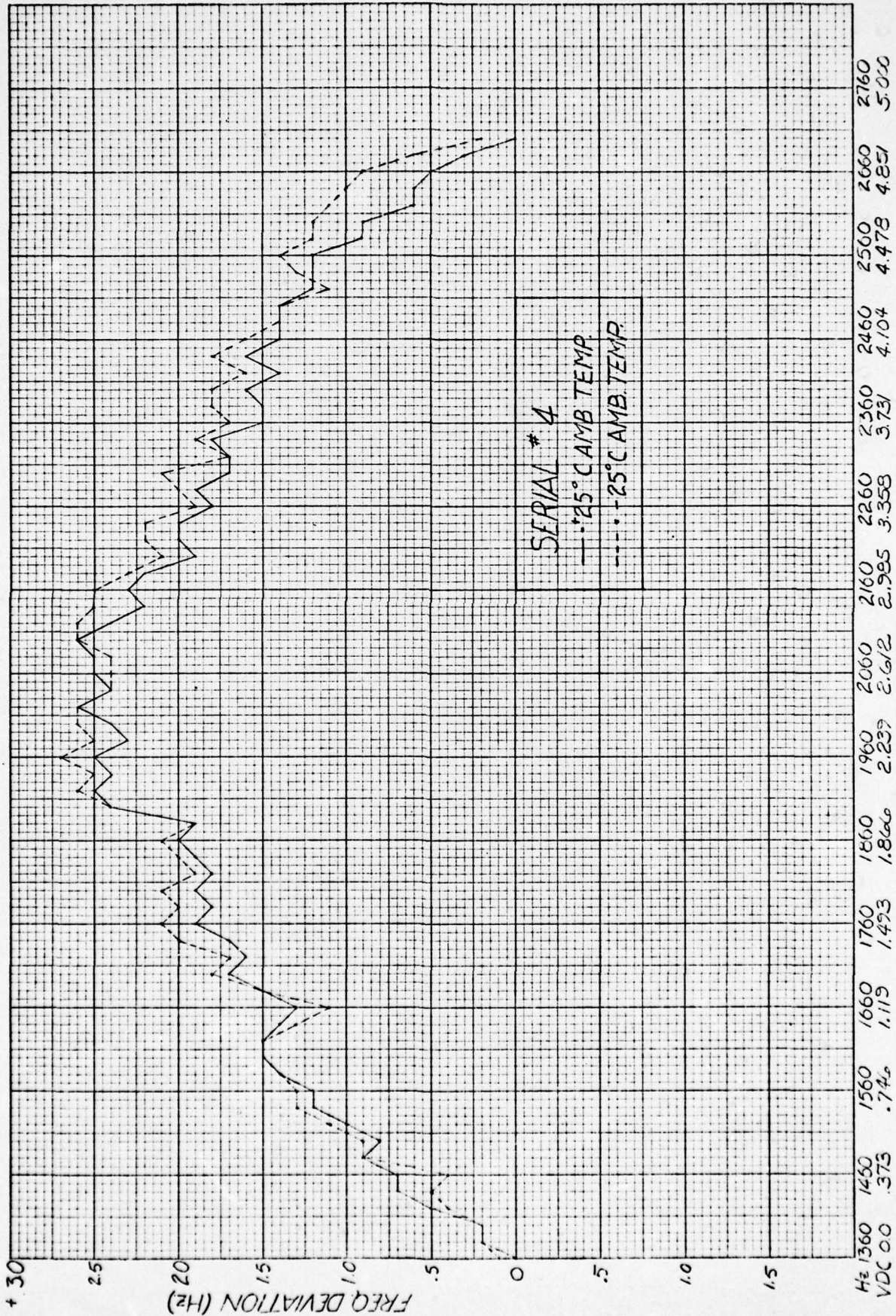


Figure 6-5 VCO Linearity vs Temperature

S/N 1	1.7 Hz		
S/N 2	2.1 Hz		
S/N 3	0.8 Hz		
S/N 4	2.5 Hz	$\frac{7.1 \text{ Hz}}{4}$	= 1.8 Hz
	7.1 Hz		

$$1.8 \text{ Hz} (0.028) = 0.050^{\circ}\text{C}$$

which can be written as  $\pm .025^{\circ}\text{C}$

#### 6.5 Ambient Temperature Change

After the calibration cycle is initiated and probe measurement starts, it is important to maintain the self-calibrating circuit at a stable ambient temperature for the two-minute period during which the XBT makes its temperature/depth profile. Testing was performed to determine the magnitude of the circuit temperature change to be expected when an AXBT enters the water.

A 2" diameter by 2" long block of epoxy (Bacon Industries FFA9/BA11) in an aluminum tube (similar to the one shown in the conceptual design) was instrumented with three thermocouples. One thermocouple was placed against the aluminum tube. The second thermocouple was placed at the center of the epoxy. The third was placed midway between the other two.

The block was then cold soaked at  $-40^{\circ}\text{C}$  until the thermocouples were at a uniform  $-40^{\circ}\text{C}$ . The block was then immersed in  $29^{\circ}\text{C}$

water and the three thermocouples monitored (see Fig. 6-6). No change was observed for over three minutes in either thermocouple within the potting material.

Since the duration of a T-7 descent is 122 seconds, it was concluded that there would not be an electronics ambient temperature change from the time of self-calibration to the end of the T-7 descent. This source of error is then negligible and may be ignored.

#### 6.6 Thermistor "S" Curve Nonlinearity

In most measurement applications the highly nonlinear resistance/temperature relationship of the thermistor requires various techniques to linearize the temperature output signal over a specified range. Users typically achieve an approximate output linearization with temperature through the use of an appropriately selected series resistor and constant voltage source. It has been shown that the normalized circuit output transfer function follows an "S" curve about a straight line. This curve is shown for the Sippican XBT and bridge circuit in Figure 6-7.

When applying the presently specified frequency-to-temperature relationship for an AN/SSQ-36 Sonobuoy ( $f = 1440 + 36t$ ), it becomes apparent that the "S" curve is a designed-in source of error of approximately  $\pm 0.45^\circ\text{C}$  at the peaks of the "S". When summed with the rest of the system error, a total deviation of approximately  $\pm 0.55^\circ\text{C}$  is possible at  $6^\circ\text{C}$  and  $28^\circ\text{C}$ . At all other points the error will be considerably less.

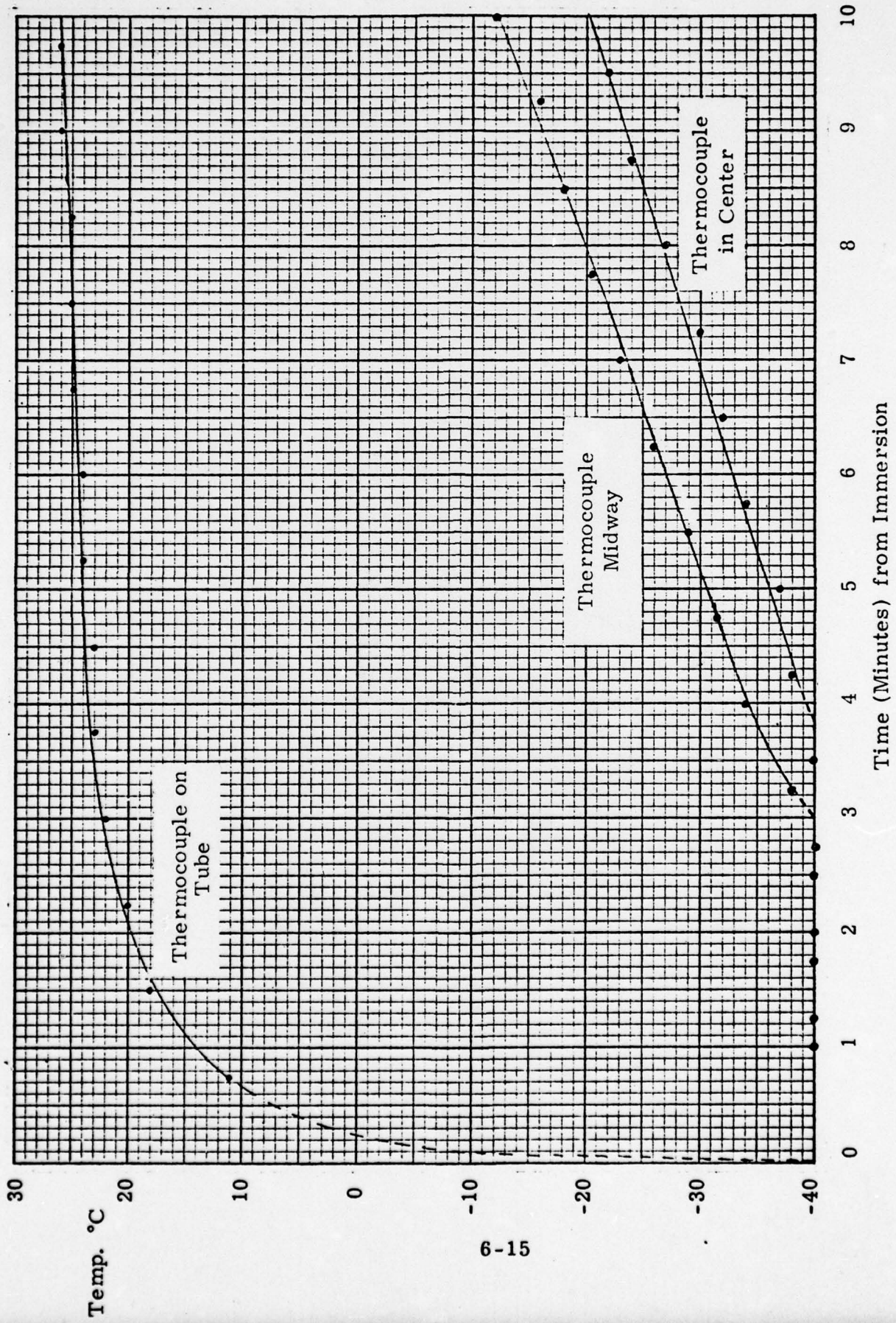


Figure 6-6 Ambient Temperature Change Test

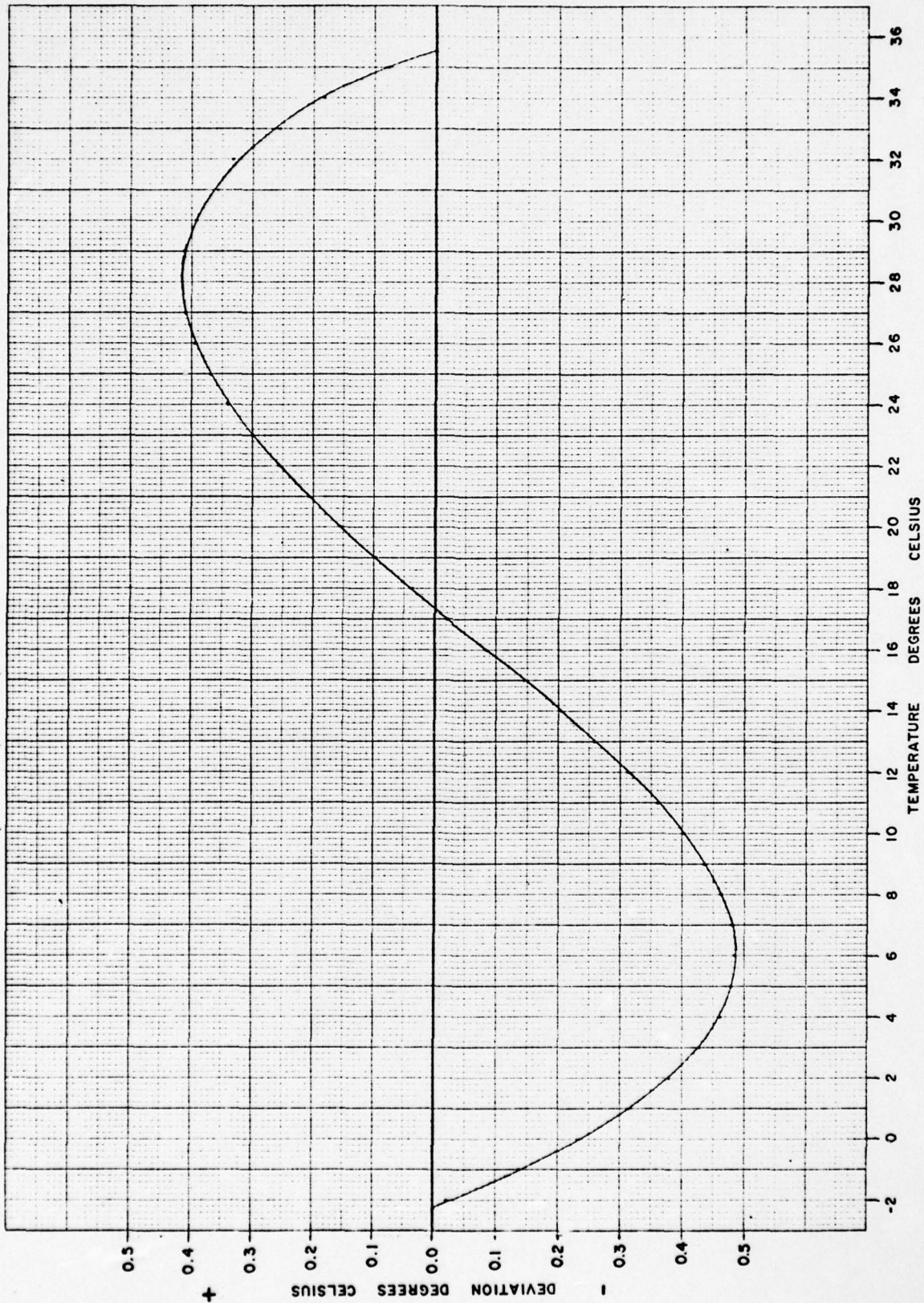


Figure 6-7 Sippican Thermistor 'S' Curve - Deviation in °C from Linear Base -2.22 to 35.55

For more precise applications where a greater temperature accuracy is required, it is desirable to express the frequency-to-temperature relationship using a computer-generated, least-squares, polynomial regression (curve fit). The basic data for the regression is the thermistor's temperature-resistance characteristic and the formula  $f = 1440 + 36t$ .

Where  $f$  is the modulating frequency in hertz from the sonobuoy and  $t$  is in degrees celsius:

$$f = A + Ft + Ct^2 + Dt^3 + Et^4$$

$$A = 1.431379 \times 10^3$$

$$B = 3.285312 \times 10^1$$

$$C = 3.2046 \times 10^{-1}$$

$$D = -6.4615 \times 10^{-3}$$

$$E = 4.0959 \times 10^{-6}$$

The maximum curve fit error is 0.015°C and occurs at 35.55°C.

6.7 Total Sum of Errors

The total sum of errors considered in this report is summarized in Table 6-2.

Source of Error	Error in Degrees Celsius (R.S.S.)		
	-2.22	16	35.55
Quartz crystal	±0.0045	±0.0068	±0.009
Calibration Resistors	±0.0045	±0.0055	±0.0065
Bridge Resistors	±0.028	±0.057	±0.052
V.C.O.		±0.025	
Supply Voltage Variation	±0.006	±0.009	±0.014
T-7 XBT Probe	±0.100	±0.100	±0.100
R.S.S. Total	±0.104	±0.119	±0.114

## TOTAL SUM OF ERRORS

TABLE 6-2

## 7.0 MECHANICAL TEST

### 7.1 Summary

Environmental testing of the T-7 probe for the purpose of this study was confined to shock testing (water impact), vibration testing (MIL-T-5422F), and temperature testing (low temperature water entry-icing). These were considered the primary possible failure causes. Other environmental testing (storage temperature, humidity, and temperature/altitude) were not considered as historical data from the Submarine-Launched XBT (SSXBT) development testing confirmed the ability of the T-7 probe to survive these environments.

The results of the testing showed that the T-7 probe can survive all the environments considered in this study.

### 7.2 Shock Test

#### Summary

Shock testing was performed to determine what levels of shock the T-7 XBT can withstand. Hydroballistic testing (firing a projectile through an air-water interface) was chosen as the primary test because of its similarity to the product end use. Due to the problems associated with instrumenting a free projectile, mechanical impact testing (striking a probe with a dead-blow hammer) was conducted with instrumented probes to obtain data on absolute shock levels.

The mechanical impact testing imparted shock pulses of  $\approx 2500$  g's at pulse widths of  $\approx 0.6$  msec. Twelve (12) T-7 probes, each subjected to two (2) impacts (one at each end), showed no visible signs of damage and worked properly when functionally tested.

Twelve (12) T-7 probes, installed in housings, were fired into the Sippican Test Tank at speeds between 156 and 190 fps during hydroballistic testing. These probes were all fired into water nose end first. All probes were inspected for damage and functionally tested. No damage was evident and all functioned properly.

One probe was fired into the test tank afterbody end first at 144 fps. This probe, when inspected, had damage to the wire coil and when functionally tested failed to dereel. This indicated that the shock levels associated with the hydroballistic testing were greater than 2500 g's (the level of the mechanical impact testing described in the probe damage test).

It was concluded that the T-7 probe could withstand the shock levels associated with an AXBT entering the ocean at 80 fps or an AXBT (PIP) entering the ocean at 125 fps, without damage.

#### Mechanical Impact Testing

#### Coupling and Resonance Search Test

Mechanical impact testing was performed on Sippican Model T-7 probes to determine to what extent an impact to the probe housing would

be transmitted to the T-7 probe and to determine if any resonances occurred in the T-7 probe due to the impact.

A T-7 probe without a probe spool was modified to mount a PCB Model 302A02 accelerometer on the forward body. This was then mounted in the probe housing and the accelerometer connected to a storage oscilloscope (see Fig. 7-1). The housing was then struck by a dead-blow hammer at the nose end and the acceleration recorded. Repeated blows indicated that the acceleration was repeatable. The recorded accelerations (see Fig. 7-2) show a pulse .6 msec. wide, with the top of the pulse "clipped off" at  $\approx 1700$  g's. The accelerometer manufacturer said that this "pulse-clipping" was caused by the internal electronics of the accelerometer and that the actual peak acceleration could be extrapolated by comparison with a shock pulse of lower amplitude in which clipping was not observed (see Fig. 7-3). The extrapolation of Figure 7-2 using Figure 7-3 showed a peak acceleration of approximately 2500 g's.

The accelerometer was then mounted directly to the housing and a T-7 without wire on the probe spool installed (see Fig. 7-4). The shock pulse of Figure 7.3 was reproduced (see Figs. 7-5 and 7-6), indicating that the shock pulse applied to the housing was transmitted directly to the T-7 probe.

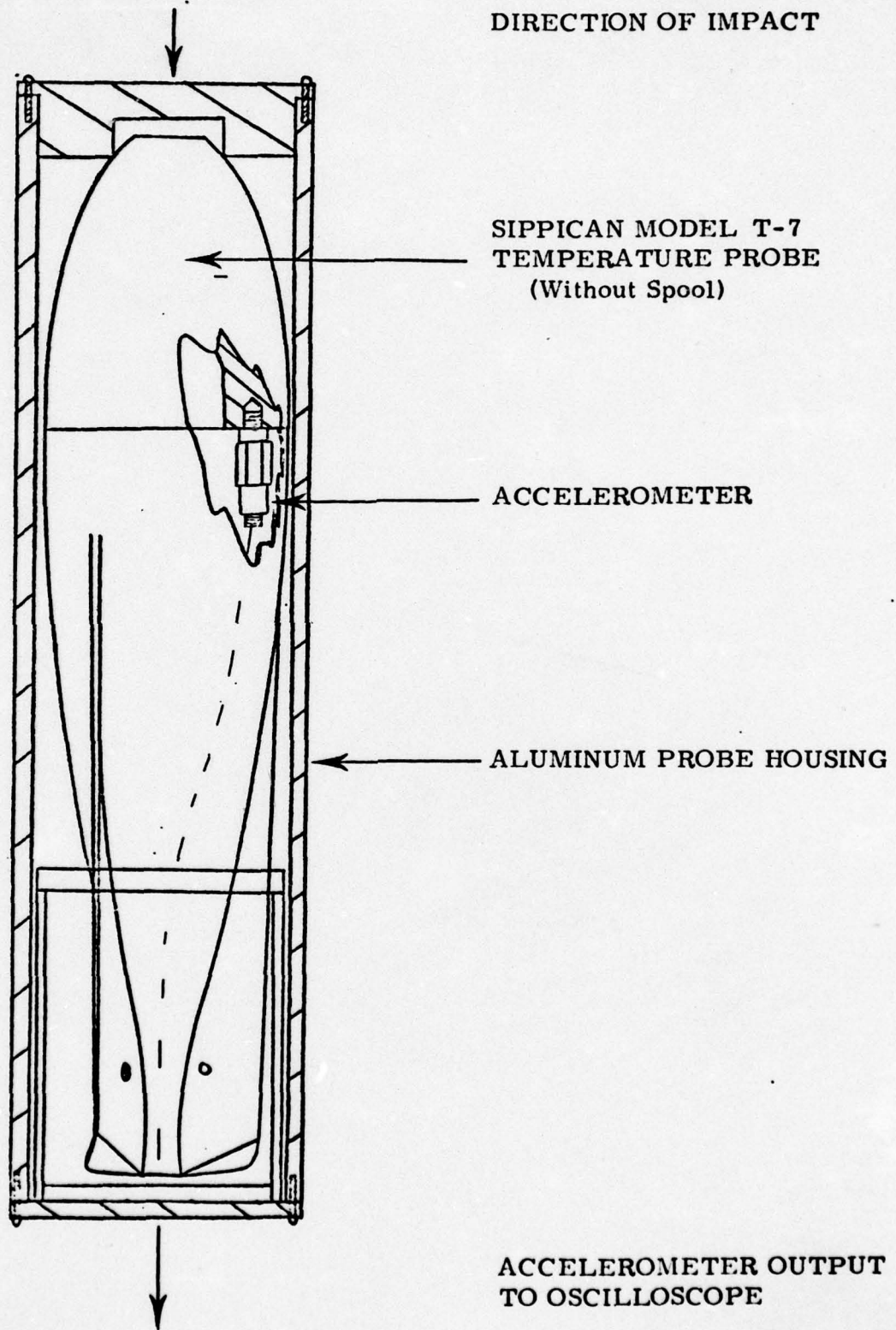
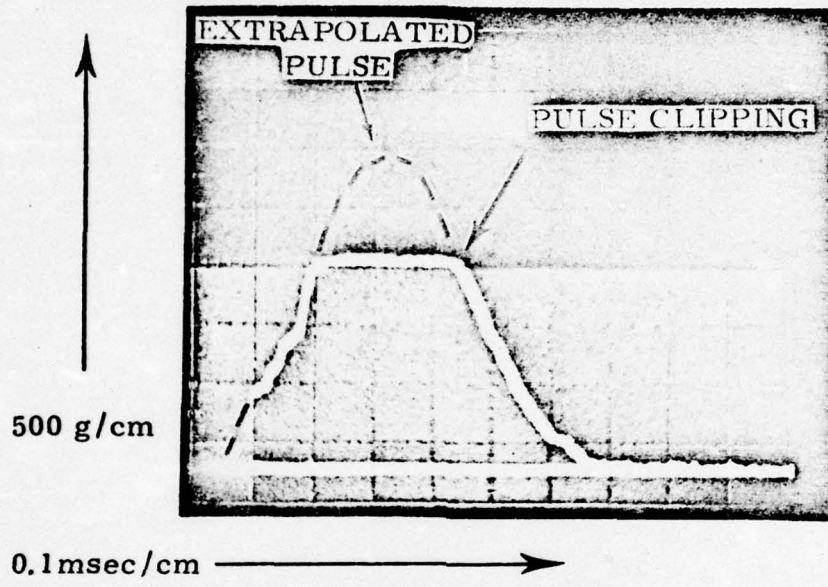
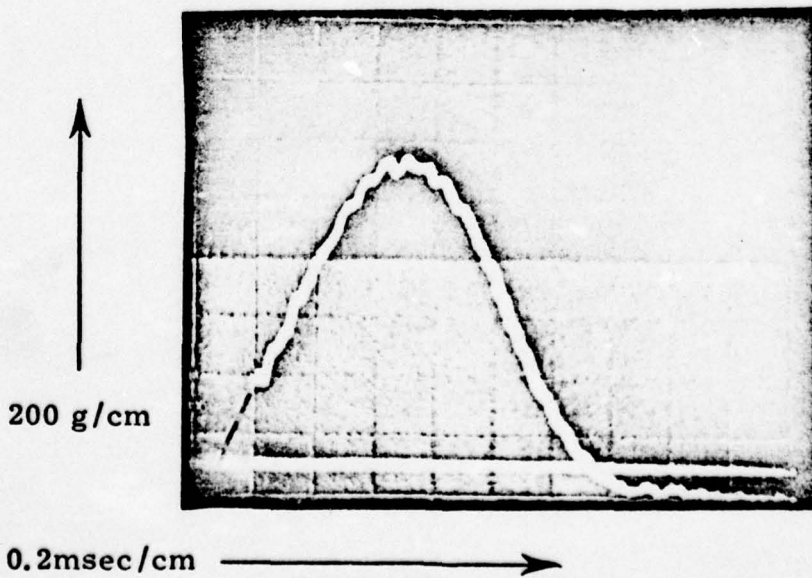


Figure 7-1



HALF SINE 2500g  
PULSE WIDTH 0.6msec

Figure 7-2



HALF SINE 1,000 g  
PULSE WIDTH 0.2msec

Figure 7-3

R-798

The Sippican Corporation

DIRECTION OF IMPACT

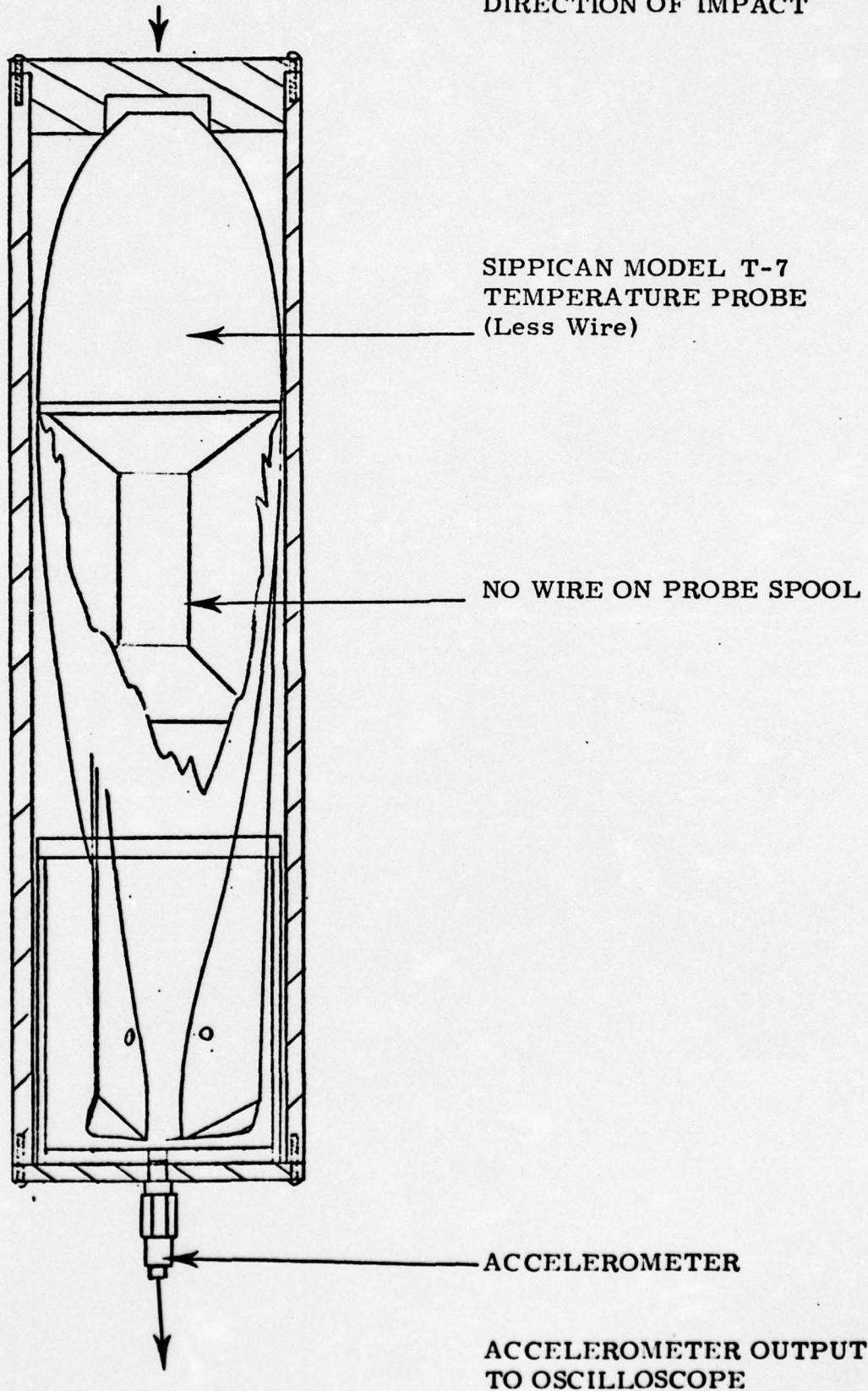
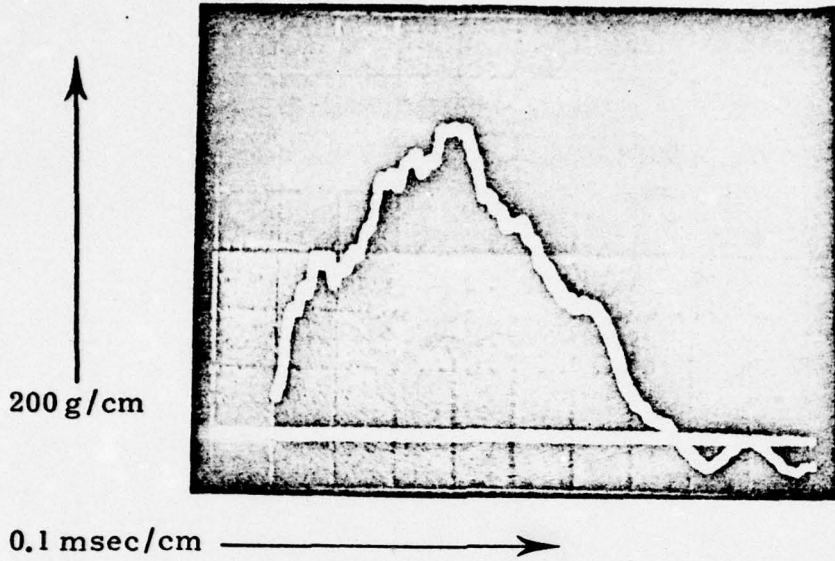
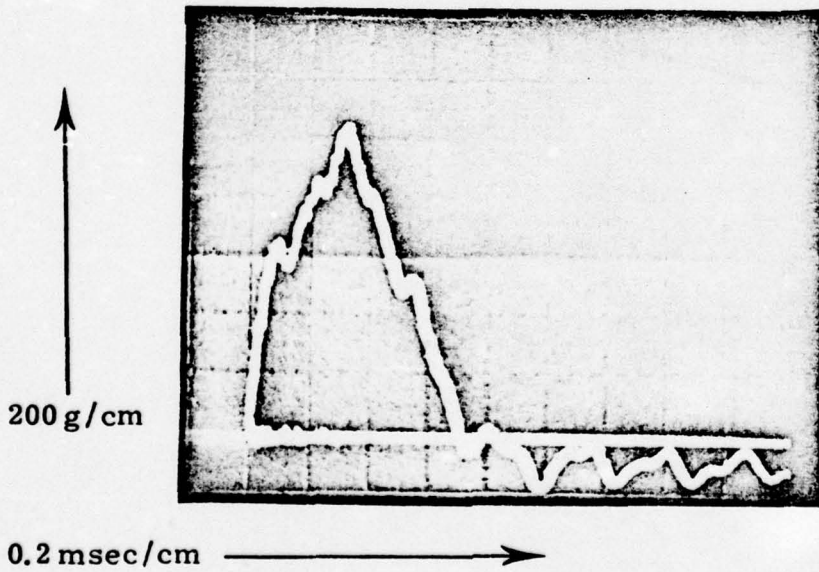


Figure 7-4



APPROXIMATE HALF SINE 1,000 g  
PULSE WIDTH 0.7 msec

Figure 7-5



APPROXIMATE HALF SINE 1,000 g  
PULSE WIDTH 0.7 msec

Figure 7-6

The T-7 probe without wire was then replaced with a complete T-7 probe from inventory (see Fig. 7-7). Full dead-blow hammer impacts (corresponding to Fig. 7-2) were applied and shock pulses recorded (see Figs. 7-8, 7-9, 7-10 and 7-11). All of these pulses showed a decaying sinusoidal acceleration at  $\approx 7.5$  KHz superimposed on the shock pulse. This sinusoidal acceleration was attributed to a resonance of the probe spool at the mounting flange.

#### Probe Damage Test

The complete T-7 probe from the resonance search test and twelve (12) additional T-7 probes from inventory which were subjected to mechanical impacts were tested for damage.

The T-7 probe from the resonance search test had been subjected to approximately twenty (20) full impacts. The remaining twelve (12) T-7 probes were each subjected to one (1) full impact at the nose end and one (1) full impact at the afterbody end while in the housing. All probes were then inspected for visible damage and the wire dereeled in the Sippican Dereeling Tank (see Fig. 7-12). There was no visible damage and all probes dereeled properly with no wire hang-ups.

R-798

The Sippican Corporation

DIRECTION OF IMPACT

SIPPICAN MODEL T-7  
TEMPERATURE PROBE  
(Complete)

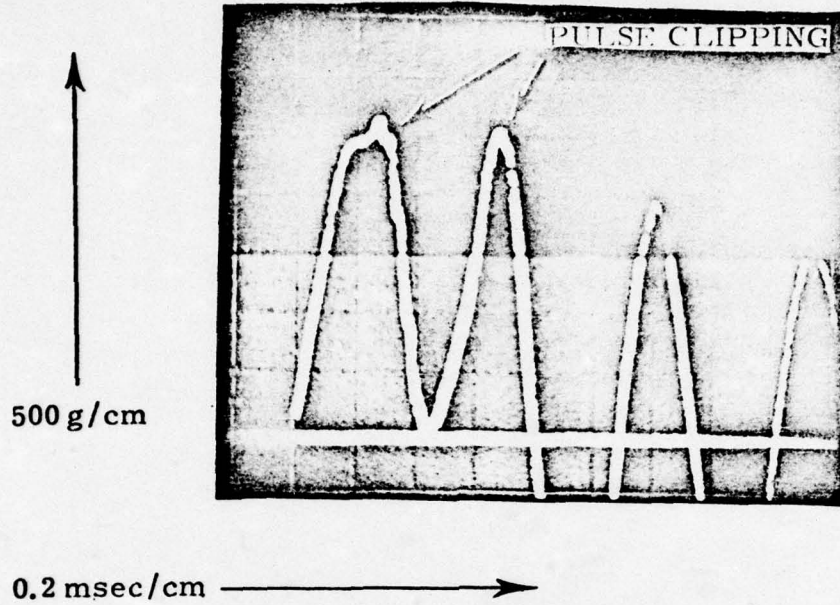
WIRE ON PROBE SPOOL

ACCELEROMETER

ACCELEROMETER OUTPUT  
TO OSCILLOSCOPE

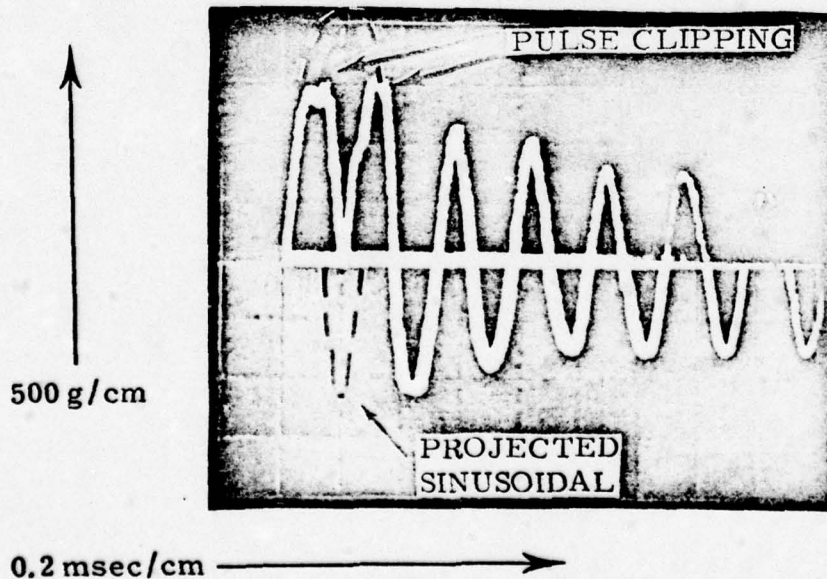


Figure 7-7



IMPACT PULSE CLIPPED AT 1,600 g  
DECAYING SINUSOIDAL ACCELERATION  
OF T-7 WIRE SPOOL

Figure 7-8



DECAYING SINUSOIDAL ACCELERATION  
OF T-7 WIRE SPOOL SUPERIM-  
POSED ON IMPACT PULSE

Figure 7-9

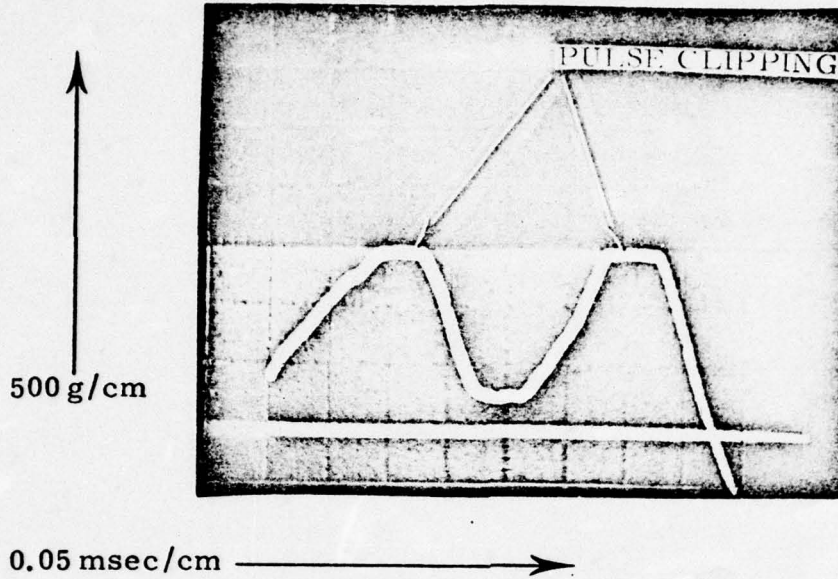
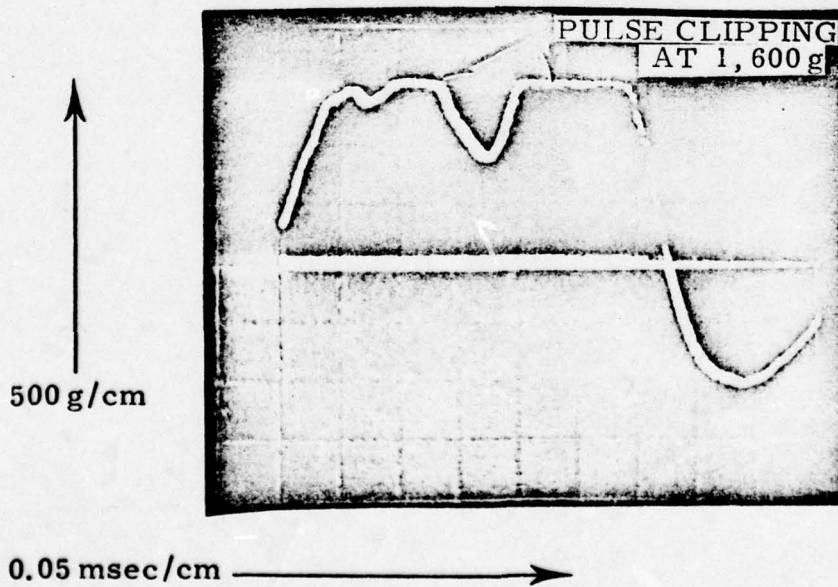


Figure 7-10



IMPACT PULSE INTERRUPTED BY  
DECAYING SINUSOIDAL ACCELERA-  
TION OF T-7 WIRE SPOOL

Figure 7-11

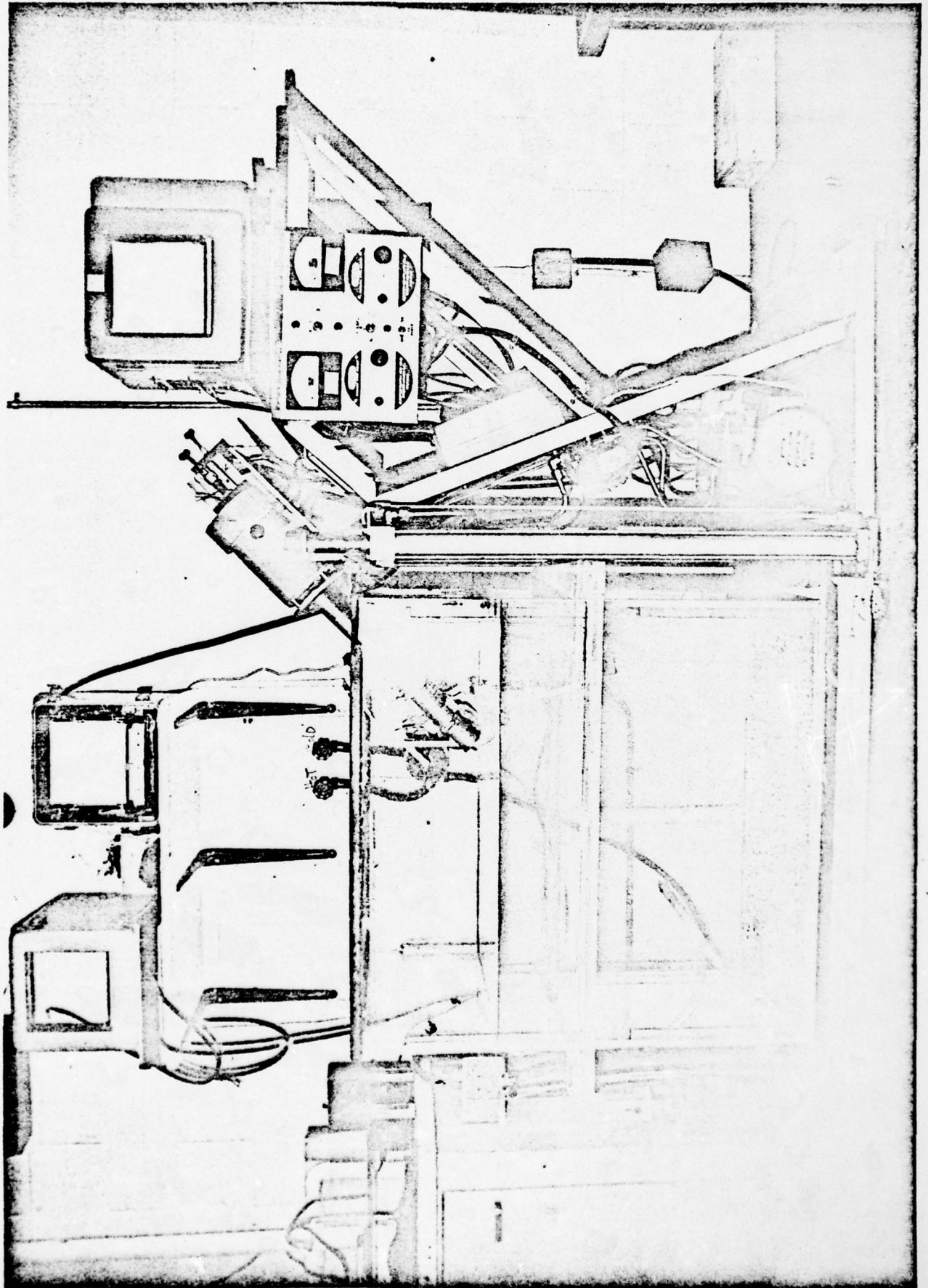


Figure 7-12 Sippican Dereeling Tank

### Hydroballistic Testing

#### Test Set-Up

An air gun was fabricated to fire the probe housing with a T-7 probe installed into the 30-foot deep Sippican Test Tank. The air gun (see Fig. 7-13) consisted of an air tank, rupture disc assembly, barrel, and photocell timing trap. An air line pressurized the air tank. Pressure increased until the rupture disc ruptured, releasing high pressure air to the barrel. A breakable link holding the probe housing in the barrel was severed and the probe housing accelerated down the barrel. After exiting the barrel, the probe housing passed through two photocell beams spaced one foot apart, and entered the water. The two photocells were connected through a time-interval gate to a Hewlett Packard 5300A counter. The first photocell started and the second photocell stopped the counter, displaying the time the probe housing took to travel the one-foot distance and, therefore, the water entry speed. Entrance speed was varied by the use of rupture discs with different values of rupture pressure.

#### Failure Mode Search Test

Twelve (12) T-7 probes were assembled without applying binder to the wire coil as is done in normal manufacture. The purpose of the binder is to prevent the wire coil from shifting, loosening wire coils, which could tangle and impede dereeling of the fine magnet wire (see

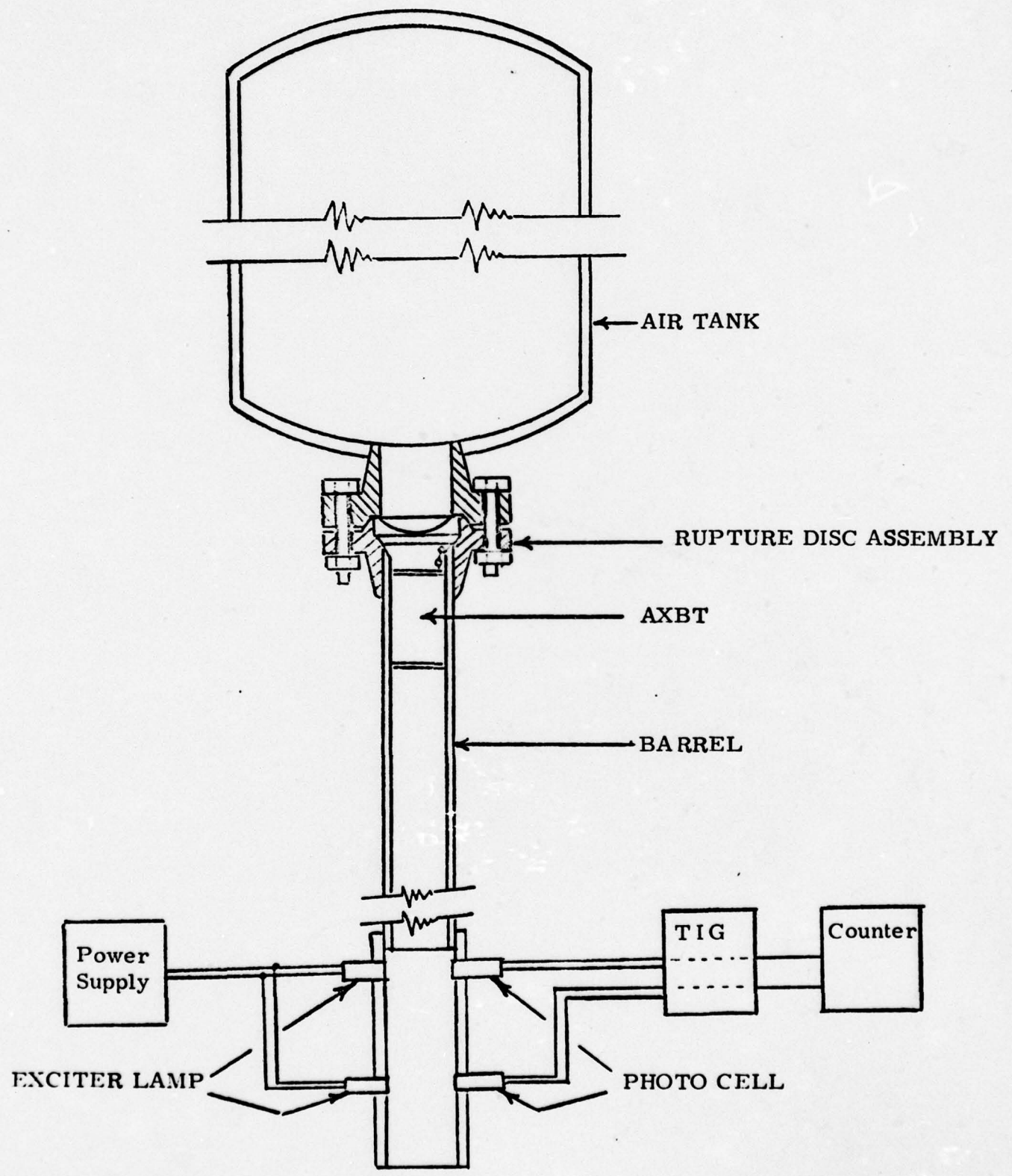


Figure 7-13 Air Gun

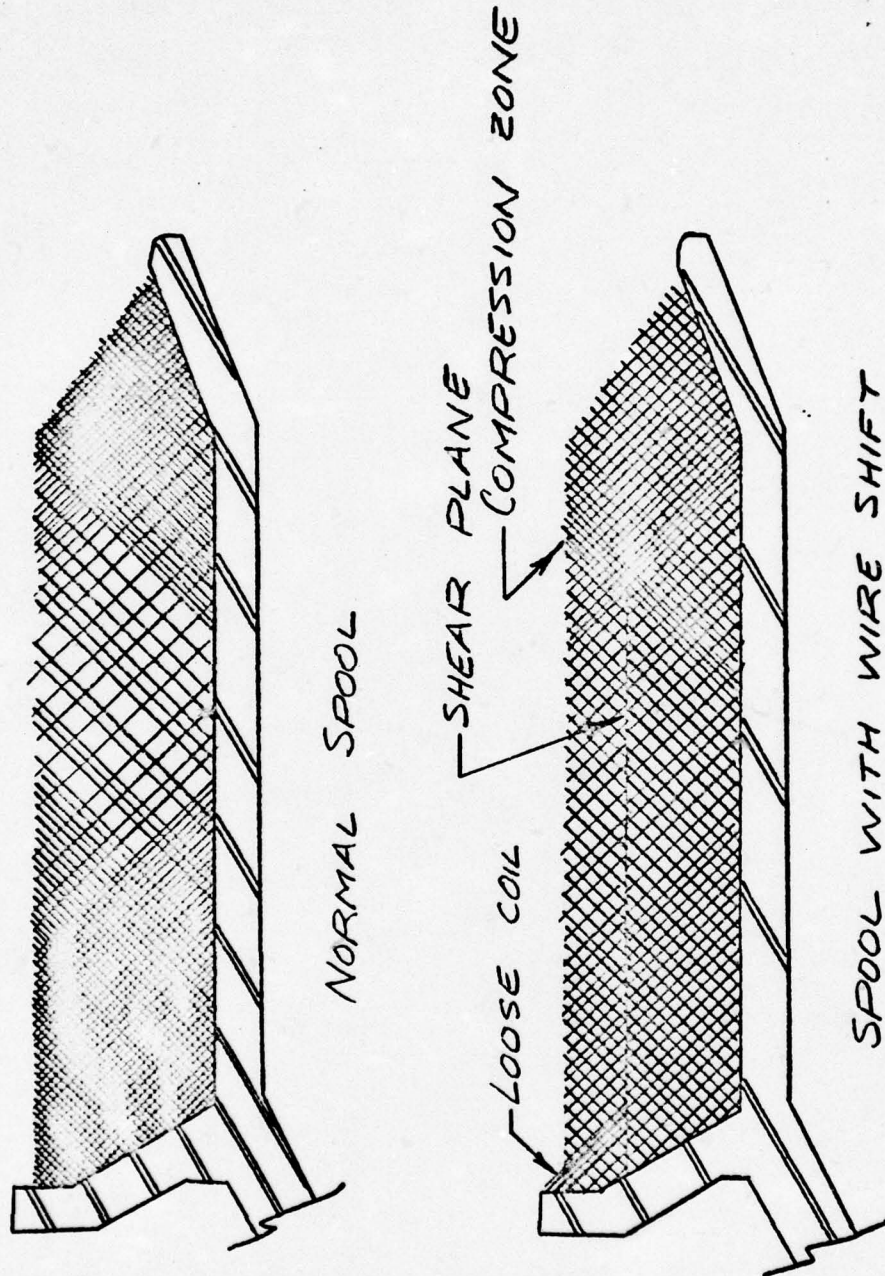
Fig. 7-14). These twelve (12) probes were then fired into the Sippican Test Tank using the air gun. Three (3) entered the water at 238 fps, three (3) at 144 fps, and six (6) at 135 fps.

All probes were then carefully disassembled and visually examined for wire coil shift. They were then dereeled underwater at 20 fps (the approximate descent speed of a T-7 probe). All probes had visible evidence of wire coil shift. None of the probes dereeled properly. All stopped dereeling well before the wire was exhausted. During an actual T-7 probe deployment at sea, a stoppage of dereeling would cause the wire to break and, therefore, cause a probe failure.

#### T-7 Probe Water Entry Test

Twelve (12) T-7 probes were then assembled using a full application of binder to the wire coil. Each probe was then installed in a housing and fired into the Test Tank to determine the entry velocity at which the failure mode described above became evident.

Three (3) probes entered the water at 156 fps, three (3) at 165 fps, three (3) at 178 fps, and three (3) at 190 fps. Each probe was then carefully disassembled and inspected. No wire coil shift was evident. Each probe was then dereeled underwater at twenty (20) fps. No failures occurred and all probes would have worked properly at sea.



WIRE COIL SHIFT

Figure 7-14

Relation Between Mechanical Impact and Water Entry Tests

One (1) T-7 probe with full binder applied was fired into the Test Tank afterbody end first in an attempt to cause the probe to fail.

The probe housing entered the water at 144 fps. The probe was then disassembled. Wire coil shift was evident and the probe did not dereel properly.

Since this did not happen to the probes in the Probe Damage Test, in which an impact to the afterbody end was applied to each probe, it can be concluded that the hydroballistic testing subjected the T-7 probes to greater accelerations than the Mechanical Impact Testing.

### 7.3 Vibration Test

#### Summary

Initially, Sippican did not intend to conduct any vibration tests as part of the feasibility study but to incorporate in this report previous test data on TSC XBT's. Vibration was not included in the work statement of the contract. However, upon reviewing previous vibration test reports on Sippican XBT products, it was determined that the frequency spectra in prior tests was directed toward shipboard vibration requirements. The only exception to this was the testing performed on the Sippican Model T-9 HXBT (Helicopter Expendable Bathythermograph). Since the design of the HXBT was of a different configuration (different probe spool) than pres-

ently manufactured XBT's and the vibration criteria was from 1968 tests, it was decided to test 24 Sippican Model T-7's to the more severe vibration tests of MIL-T-5422F, Procedure II, Curve III, from 15 - 2000 Hz.

Of the 24 probes tested, three failed when functionally tested. One of the failures was a manufacturing defect; the other two were a result of the vibration test. Both vibration failure modes are easily correctable in the design of the AXBT/EA.

#### Test Procedure and Visual Inspection

Since a design for packaging the T-7 temperature probe and its associated electronics has not been finalized, a vibration test fixture to test individual or multiple T-7's was considered to be too expensive and time consuming to achieve a reasonable sample size.

Therefore, Sippican elected to test standard T-7 temperature/depth probes to MIL-T-5422F, Procedure II, Curve IIIA in their standard shipping containers. Two cases (24 probes) of T-7 XBT's were drawn from Sippican inventory and shipped to Associated Testing Labs, Inc., along with a vibration fixture designed to attach the cases for the vibration tests. A copy of Associated Testing Labs report is included in Appendix I.

Upon return to Sippican the two cases of probes were opened and any external damage noted. The probe was then removed from the canister, any damage noted, and then dereeled in the Sippican Dereeling Tank, while connected to a MK2A-1 Recorder.

All testing and failure mode analysis was performed under the cognizance of Sippican's Manager of Reliability and Quality Assurance, Mr. Robert P. Demeo.

Upon opening the two cases of T-7's the following observations were noted:

1. The webbing inside the shipping containers, designed to keep the probes separated, was completely destroyed, thus allowing the canisters to bang against each other.
2. The plastic bags housing the individual T-7's were torn or abraded through at the canister spool and launch pin.
3. All of the launch pins were loose. This was caused by the repeated banging of adjacent canisters, forcing the Tinnerman clips to gradually displace, once the webbing on the shipping container let go. Further examination showed that the launch pins had created indentations in adjacent canisters.
4. Seven of the twenty-four T-7 launch pins had the Tinnerman clips completely forced off and were found laying at the bottom of the plastic bags.
5. One launch pin that had lost its clip was half way out of the canister, thus losing retention and support of the T-7 temperature probe.

6. The plastic bags contained broken-up pieces of the shipping container and black chips of plastic.

Function Examination-Procedure

Upon completion of the external inspection of the twenty-four T-7's, the units were individually removed from the shipping containers. Each T-7 was inspected and tested in the following manner:

1. The T-7's were removed from the plastic bag and visually inspected.
2. The nose cap was removed and inspected. The T-7 canister was placed in the launcher of the dereeling tank.
3. The T-7 temperature probe was removed from the canister and positioned underwater in the probe retaining fixture in the dereeling tank.
4. The breech on the launcher of the dereeling tank was closed and the recorder was cycled into the measure mode.
5. With the recorder in the measure mode, the trace was monitored for approximately ten to fifteen seconds prior to dereeling in order to witness any T-7 malfunctions caused directly by the vibration test.
6. After analyzing the T-7 in the measure mode, the canister and temperature probes were dereeled at the rated ship speed

and probe terminal velocity simultaneously, and a trace was recorded for each probe.

7. Each trace was analyzed during and after dereeling for any abnormalities.

8. When the dereeling tests were completed, the units were completely disassembled and visually inspected for damage.

#### Functional Examination-Results

Of the twenty-four T-7's that underwent MIL-T-5422F in their standard shipping containers, twenty-one produced perfect traces in the dereeling tank. The three T-7's that did not produce perfect traces failed in three different modes. Each failure mode is discussed below in detail.

1. When the T-7 was monitored in the measure mode prior to dereeling, there was no evidence of any defects. However, when the canister spool and probe spool dereeling sequence began, the canister spool did not dereel. The canister dereeling pinch rollers were shut off and the probe spool dereeled perfectly to its normal depth. Upon disassembly of the T-7 canister and spool, it was determined that the canister spool had a "half hitch" in the wire, thus preventing the spool from dereeling. This failure was classified as a manufacturing error created at the final assembly of the T-7 and was not a result of the test.

2. The second T-7 which failed was observed to be erratic in the measure mode prior to dereeling; however, upon dereeling, the probe and canister dereeled to their full capacity. The recorded trace exhibited large discrete wire leaks throughout the trace. Unfortunately, this probe was the same one that had the launch pin dislodged, making the failure analysis somewhat more difficult; i. e., was the wire leakage inherent in the T-7 or was it caused by the vibration test itself. Upon complete disassembly of the T-7 probe and canister, the damage to the component parts was so severe that a single cause or causes could not be isolated to determine if the test caused the wire to leak or the wire was bad prior to the test. Because of the nature of the leakage (several discrete leaks throughout the dereeling), it is surmised that the leakage was attributed to the physical damage to the T-7 as a result of the vibration test.

3. The third failure was directly attributed to the vibration test. The T-7 temperature probe exhibited a failure upon immersion of the nose into the water in the dereeling tank. The pen went immediately offscale, indicating a leak in the thermistor coating. This was verified by a continuity check, indicating all connections were intact and proper. The probe and canister spools were dereeled to observe whether any loose wire or other defects could be observed. There were none. After completion of the dereeling, the probe was disassembled and the thermistor ana-

lyzed under a microscope. This examination immediately revealed the cause of the leak in the thermistor to be a fragment (or chip) of green paint (used by Sippican to distinguish a T-7 nose from those used in our other probes) impaled in the thermistor coating on the lead. This failure was probably caused during the vibration test at the higher frequencies, where a loose chip of the paint was shaken off and driven into the coating, thus creating the leak.

In conclusion, the vibration tests were considered to be successful in that the tests were performed on standard T-7 XBT's in their standard shipping containers which were designed to meet the vibration requirements of MIL-E-16400 for shipboard use, not the higher frequency and more severe airborne vibration requirements of MIL-T-5422F. The two vibration-related failures (2 and 3) are easily correctable for AXBT use. The probe release mechanism will be designed to survive the requirements of airborne vibration and paint will not be applied to the T-7 nose.

Further testing will be required when a final configuration for the T-7 in a sonobuoy AXBT package is designed.

#### 7.4 Probe Temperature Test

##### Summary

Initially, Sippican did not intend to conduct any temperature tests on the T-7 probe. At the request of NADC, temperature testing was conducted to determine the results of a cold soak at  $-53^{\circ}\text{C}$  and then immersion into  $-2.2^{\circ}\text{C}$  water (1.5% salinity). The T-7 probe failed due to severe icing of the wire coil preventing dereeling. It was decided to test an AN/SSQ-36 under similar conditions. It also failed due to failure of the seawater battery to turn on and failure of the probe to release.

After discussions between Sippican and NADC, it was decided to conduct further testing at  $-40^{\circ}\text{C}$  and  $-20^{\circ}\text{C}$  (the standard sonobuoy spec) on T-7 probes and on six (6) government-furnished AN/SSQ-36's manufactured by Magnavox (three at each temperature).

At  $-40^{\circ}\text{C}$  and  $-20^{\circ}\text{C}$  the T-7 probe was not adversely affected. the six (6) AN/SSQ-36's failed.

##### Test Results

The temperature test results are summarized in Table 7-1.

All tests were run by cold soaking the probes at  $-40^{\circ}\text{C}$  or  $-20^{\circ}\text{C}$  in air followed by immersion in  $-2.2^{\circ}\text{C}$ , 1.5% salinity water. In the case of the AN/SSQ-36 probes, a probe release was attempted.

**TABLE 7-1**  
**PROBE TEMPERATURE TESTS**  
**(MECHANICAL)**  
**-2. 2°C (1. 5% SALINITY) TEMPERATURE BATH**

**TEST SAMPLES**

Probe Soak Temp. (1)	T-7 Probe Spool Only	Complete T-7 Std.	Complete T-7 Modified (2)	Forebody T-4 T-7 Modified (3)	AN/SSQ-36 (4)	Forebody T-7 Modified (2)	Sea Water Batteries (5)
-53°C Remarks (See Table of Codes)	D, E	-	-	- -	B, C, D, E F, G	-	A
-40°C		C, F, G, H	F, G, J	F, G, I	B, C, D, E F, G, L	F, G	A
-40°C T-7 moving slowly		G, J					
-20°C T-7 moving slowly		G, J			B, C, D, E F, G L(2 out of 3)		A (2 out of 3 tested)

**TABLE OF CODES**

Code	REMARKS
A	NO SEAWATER BATTERY TURN ON.
B	THERMISTOR ICED OVER 1/16 IN. AFTER 15 SECONDS.
C	THERMISTOR SKINNED OVER IMMEDIATELY.
D	WIRE COIL ICED OVER PREVENTING PROPER DEREEING.
E	SINK RATE AFFECTED BY CODE "D".
F	FOREBODY ICED OVER 1/16 IN. AFTER 15 SECONDS.
G	FOREBODY SKINNED OVER IMMEDIATELY.
H	FOREBODY HOLE CLOSED.
I	INSIDE DIAMETER OF FOREBODY REDUCED TO 3/16 IN. OR LESS.
J	NO PERFORMANCES PROBLEMS.
K	TO BE DETERMINED.
L	PROBE FAILED TO RELEASE.
(1)	COLD SOAK FOR MINIMUM OF 3 HOURS.
(2)	T-7 THERMALLY DECOUPLED BY INSERT.
(3)	T-7 THERMALLY DECOUPLED 4 LAYERS OF KRYLON ACRYLIC SPRAY.
(4)	COMPLETE TEMPERATURE PROBE.
(5)	TO CONFIRM MANUFACTURER'S DATA (NO TURN ON BELOW -20°C).

Two tests were run on T-7 probes soaked at  $-40^{\circ}\text{C}$ . In the first test the T-7 probes were placed in the water bath and not moved. Severe icing resulted. In the second test at  $-40^{\circ}\text{C}$  (and the test at  $-20^{\circ}\text{C}$ ) a procedure more realistically simulating the actual use of a T-7 probe in the AXBT/EA was used. Since the T-7 probe will be kept dry until deployment, the test probes were raised and lowered in the water bath simulating the T-7 descending through the water. The raising and lowering was at approximately 2 fps which is well below the T-7 drop rate ( $\approx 20$  fps) and is, therefore, very conservative. Under these conditions the forebody iced over slightly but probe functioning would not have been impaired.

Three (3) GFE AN/SSQ-36's were soaked at  $-40^{\circ}\text{C}$  and then tested. They failed to release the probe and the seawater battery failed to turn on.

Three (3) GFE AN/SSQ-36's were soaked at  $-20^{\circ}\text{C}$  and then tested. Two (2) failed to release the probe. The third released the probe but icing of the wire coil was so severe that dereeling of the signal wire was impeded, which would affect descent rate and depth accuracy. The seawater battery turn-on was marginal (two (2) failed to turn on). Conversations with other sonobuoy manufacturers confirmed that  $-20^{\circ}\text{C}$  cold soak and then immersion into  $-2.2^{\circ}\text{C}$  water is the practical lower temperature limit for the seawater batteries.

## 8.0 CONCLUSIONS AND RECOMMENDATIONS

The feasibility study for incorporating a Model T-7 Temperature Probe into an AXBT has resulted in breadboard circuitry which demonstrates that the  $\pm 0.2^{\circ}\text{C}$  accuracy of the shipboard T-7 may also be achieved in an improved AN/SSQ-36 Sonobuoy. Additionally, testing proved the ability of the T-7 probe to withstand the environmental conditions encountered by an AXBT. This increases depth measurement capability from the present 300 meters to the T-7 depth of 760 meters. The inherent ability of the self-calibrating electronics to operate over extreme temperature ranges and have a long shelf life with a minimum number of precision components is unique. The use of state-of-the-art technology insures us of long design life without the hidden dangers of early obsolescence.

It is now recommended that the program investigate in greater depth the most economical ways to produce the AXBT/EA to meet the cost goals and accuracy requirements for production quantity units. This will include investigation into the design of the electronics utilizing microelectronics technology inclusive of thin films, custom integrated circuits, custom hybrid circuits, Medium Scale Integration (MSI), Large Scale Integration (LSI) in conjunction with discrete components where economics dictate the cost/performance trade offs. The mechanical packaging of the electronics and temperature probe will also be initiated with primary emphasis on

R-798

The Sippican Corporation

shock, vibration and temperature. Predesign requirements must be established for such items as power supply (batteries), electromechanical interface and mode sequencing.

As a result of the detailed investigations, cost/performance trade offs will be made. Detailed production cost forecasts including the non-recurring elements of production design and tooling plus the recurring circuit, probe, and packaging cost will be reported.

R-798

The Sippican Corporation

APPENDIX I

Test Report No. T-4300-11

No. of Pages 4

# Report of Test on

■SXBT INSTRUMENTS

SINE VIBRATION TESTING

for

THE SIPPICAN CORPORATION

## Associated Testing Laboratories, Inc.

Date September 13, 1976

	Prepared	Checked	Approved
By	C. R. Muise	E. R. Mencow	E. E. Kulcsar
Signed	<i>C. R. Muise</i>	<i>E. R. Mencow</i>	<i>E. E. Kulcsar</i>
Date	<i>9/14/76</i>	<i>9/15/76</i>	<i>9-16-76</i>

## Administrative Data

### 1.0 Purpose of Test:

To subject the ■SXBT Instruments to sine vibration testing in accordance with the referenced specifications and test procedure of this report.

### 2.0 Manufacturer:

The Sippican Corporation  
P. O. Box 139  
Marion, Massachusetts 02738

### 3.0 Manufacturer's Type or Model No.: ■SXBT Instruments

### 4.0 Drawing, Specification or Exhibit:

MIL-T-5422F and verbal instructions from The Sippican Corp.

### 5.0 Quantity of Items Tested:

Two (2) Lots (12 units per lot)

### 6.0 Security Classification of Items:

Unclassified

### 7.0 Date Test Completed:

September 8, 1976

### 8.0 Test Conducted By: Associated Testing Laboratories, Inc.

### 9.0 Disposition of Specimens:

Returned to The Sippican Corporation.

### 10.0 Abstract:

There was no physical damage to the ■SXBT Instruments as a result of the Vibration Test. The units were returned to The Sippican Corporation for further evaluation.

LIST OF APPARATUS

<u>Item</u>	<u>Manufacturer</u>	<u>Model No.</u>	<u>Accuracy</u>	<u>Calibration Date</u>	<u>Calibration Due Date</u>
Control Console			A. ±5% F. ±2%	7-15-76	10-15-76
Accelerometer	Endevco Corporation	2215E	±5%	9-1-76	12-1-76
Vibration System	Ling Electronics	335#2	±5%	9-4-76	12-4-76

Report No. T-4300-11

Page 2

**Associated Testing Laboratories, Inc.**

Wayne, New Jersey 07470

Burlington, Massachusetts 01803

## SINUSOIDAL VIBRATION TEST

### TEST PROCEDURE

The test specimens were subjected to a sinusoidal vibration test in accordance with the referenced specification, as follows.

The components were securely attached to a test fixture which was attached to the table of the vibrator. Each package was then subjected to sinusoidal vibration over the frequency range of 15 to 2000 Hz. The test was conducted in two parts which are described below:

#### Part I

The components were vibrated in each of the three major mutually perpendicular axes through the applicable frequency range at the amplitudes indicated in Table I. The frequency range of 15 Hz to 2000 Hz to 15 Hz was traversed in a time of 20 minutes. The time duration was two complete sweeps (15-2000-15) in each axis. The units were non-operational during this test.

Table I

<u>Frequency (Hz)</u>	<u>Level</u>
15 - 20	0.1 inch d.a.
20 - 30	2.0g's
30 - 52	0.036 inch d.a.
52 - 2000	5g's

#### Part II

The components were vibrated in each of the three mutually perpendicular axes. The frequency range of 15 Hz to 2000 Hz to 15 Hz was traversed in a time of 20 minutes. The components were subjected to four hours of cycling at the levels in Table II.

SINUSOIDAL VIBRATION TEST

TEST PROCEDURE (continued)

Part II (continued)

Table II

<u>Frequency (Hz)</u>	<u>Level</u>
15 - 28	0.18 inch d.a.
28 - 2000	7g's

At the completion of the four hours, one additional sweep in accordance with the requirements of Part I was performed. The units were non-operational during Part II of vibration.

TEST RESULTS

The components exhibited no signs of physical damage. The units were returned to The Sippican Corporation for further evaluation.

