

AD-A040 258

NAVAL RESEARCH LAB WASHINGTON D C
SECONDARY ELECTRON SUPPRESSION IN CHARGE COLLECTORS AND ANALYZE--ETC(U)
MAY 77 B H RIPIN, R DECOSTE

F/G 20/3

UNCLASSIFIED

NRL-MR-3494

NL

4 OF 24
AD
AD40258



END

DATE
FILMED
6-77

ADA 040258

[Handwritten mark]

NRL Memorandum Report 3494

24

Secondary Electron Suppression in Charge Collectors and Analyzers

B. H. RIPIN and R. DECOSTE

*Laser Plasma Branch
Plasma Physics Division*

May 1977



DDC
RECEIVED
JUN 8 1977
A

AD No. _____
DDC FILE COPY

NAVAL RESEARCH LABORATORY
Washington, D.C.

Approved for public release; distribution unlimited.

SECURITY CLASSIFICATION OF THIS PAGE (When Data Entered)

REPORT DOCUMENTATION PAGE		READ INSTRUCTIONS BEFORE COMPLETING FORM
1. REPORT NUMBER NRL Memorandum Report 3494	2. GOVT. ACCESSION NO.	3. RECIPIENT'S CATALOG NUMBER 14) NRL-MR-3494
4. TITLE (and Subtitle) 6) SECONDARY ELECTRON SUPPRESSION IN CHARGE COLLECTORS AND ANALYZERS.	5. TYPE OF REPORT & PERIOD COVERED 9) Interim report on a continuing NRL problem.	6. PERFORMING ORG. REPORT NUMBER
7. AUTHOR(s) 10) B.H. Ripin R. Decoste	8. CONTRACT OR GRANT NUMBER(s)	
9. PERFORMING ORGANIZATION NAME AND ADDRESS Naval Research Laboratory Washington, D.C. 20375	10. PROGRAM ELEMENT, PROJECT, TASK AREA & WORK UNIT NUMBERS NRL Problem H02-29A 12) 11P.	
11. CONTROLLING OFFICE NAME AND ADDRESS Energy Research and Development Administration Washington, D.C. 20545	12. REPORT DATE 11) May 1977	13. NUMBER OF PAGES 11
14. MONITORING AGENCY NAME & ADDRESS (if different from Controlling Office)	15. SECURITY CLASS. (of this report) UNCLASSIFIED	15a. DECLASSIFICATION/DOWNGRADING SCHEDULE
16. DISTRIBUTION STATEMENT (of this Report) Approved for public release; distribution unlimited.		
17. DISTRIBUTION STATEMENT (of the abstract entered in Block 20, if different from Report)		
18. SUPPLEMENTARY NOTES Work performed at the Naval Research Laboratory under the auspices of the Energy Research and Development Administration. *University of Maryland, College Park, Maryland.		
19. KEY WORDS (Continue on reverse side if necessary and identify by block number) Analyzer Charge collector Secondary Suppression Laser-plasma		
20. ABSTRACT (Continue on reverse side if necessary and identify by block number) A modification of the simple parallel plate electrostatic analyzer is described which allows suppression of secondary particles without electrodes within the particle flux and allows relatively easy measurements of secondary emission coefficients.		

DD FORM 1473 1 JAN 73

EDITION OF 1 NOV 65 IS OBSOLETE
S/N 0102-014-6601

SECURITY CLASSIFICATION OF THIS PAGE (When Data Entered)

251 950

mtt

SECONDARY ELECTRON SUPPRESSION
IN
CHARGE COLLECTORS AND ANALYZERS

RECEIVED/AVIATION GROUP
1977 APR 12 10 41
A

Simple parallel electrodes, electrostatic energy analyzers and charge collectors, as shown in Fig. 1a for example, have been widely used to obtain electron and ion current distributions. The simplicity of the construction and the analysis of data from these devices, however, is somewhat offset by their susceptibility to error from secondary emission within the detector.¹⁻⁴ We will describe here a scheme which allows suppression of secondary particle emission while retaining the advantages of the simplest device.

The typical ion charge collector (Fig. 1a) has openings on the first grid (or entrance hole or slit) less than the Debye length of the impinging plasma so that the electrons can be separated from the ions. In Fig. 1a, a negative bias is usually applied to the collector to repel plasma electrons and secondary electrons from the first grid and attract slow ions. However, secondary electrons are knocked out of the collector (or any portion of the analyzer that is struck by particles), and if not recollected, contribute to the detected current. Efforts to suppress these secondaries by grids in front of the collector, (Fig. 1b), are only partially successful since they themselves contribute secondary electrons due to being struck by particles. When secondary emission coefficients are large (due to high energy incident particles) even highly transparent grids contribute currents which may dominate over incident fluxes. Another method used to suppress secondaries are magnetic fields placed perpendicular to the collector plates² (Fig. 1c). These magnetic fields reflect secondary electrons

Note: Manuscript submitted April 12, 1977.

back into the collector plate and thereby cause them to be recollected. One disadvantage of this technique is that a plasma drift can be created within the analyzer due to crossed electric and magnetic fields which can reduce the suppression efficiency. Another drawback to magnetic suppression is that the magnitude of the magnetic field puts restrictions on both the axial and transverse momenta of particles that may be accurately analyzed. Still another technique to minimize secondary effects is the usage of the faraday cup geometry (Fig. 1d). A disadvantage here is that the signal-to-noise ratio is reduced because of the smaller collection area.

The device that is described here to suppress secondary particle emission is illustrated in Fig. 2. The suppression grid is simply replaced by a conducting tube with large length to diameter ratio. When a potential V_0 is applied to this tube, the region within the tube assumes a potential very close to V_0 . In fact, the on-axis potential halfway into such a tube of length L and radius a ($L \gg a$) is given by.⁵

$$\frac{V(0, \frac{L}{2})}{V_0} = 1 - \frac{4e^{-(v_{01} L/2a)}}{v_{01} J_1(v_{01})} \quad (1)$$

where v_{01} is the first zero of the Bessel function $J_0(v_{01}) = 0$. For example, when $L/a = 4.8$ then the potential everywhere within the tube is within 1% of the applied potential. The tube then supplies the suppression potential without physically intercepting the particles. The tube, therefore, cannot be a source of secondaries, as can a grid, nor are there any contact potentials to worry about. The entrance grid (or hole) can still be used for the separation of the electrons from the ions of the incident plasma when the device is used as an ion collector but, in any case, should be small enough that the final diameter of the beam is less than the diameter of the tube. Both geometric and space charge expansion should be considered here.⁶ Geometries other than tubes such as parallel plates may be desirable for some applications and in principle are possible. Tubes placed in tandem can take the place of multiple grids.

A device of this type was used successfully as an electron energy analyzer with the biasing shown in Fig. 2a, and more recently, as an ion time-of-flight charge collector for laser fusion studies (Fig. 2b). The operation in the electron analyzer mode has been described previously by the first author.⁵ Here, we will discuss its properties as a time-of-flight ion collector, its application towards the absolute calibration of an ion species analyzer and as a method to measure secondary emission coefficients.

The uncertainty in secondary electron coefficients and their functional dependence upon species, ionization state and energy of ions produced by short pulse laser produced plasmas is of major concern for quantitative evaluation of the popular ion charge collector data.

A comparison of current traces of an analyzer with a tube (Fig. 2b) and a grid (Fig. 1a) on the same laser shot and at almost the same angular position is shown in Fig. 3. These data were obtained in the irradiation of a planar polyethelene target by a focused Nd-laser beam of duration 100 psec and irradiance of $\sim 10^{15}$ W/cm².⁴ Comparison of these traces yield, after scaling for differences in solid angles subtended by the two analyzers and distances from the plasma source, average electron secondary coefficients for ions of interest with speeds of $v < 10^7$ cm/sec. Comparison of these traces with data from an ion species analyzer⁶ shows that the differences in shapes of these two traces are due to distortions caused by differences in secondary coefficients of hydrogen and various carbon species at the same velocity and the variation of the secondary electron coefficient as a function of energy.⁷ Figure 3c shows the average secondary emission coefficients, γ , obtained by taking the ratio of the traces in 3(a) and 3(b).

Many ion species analyzers are using the same collection system principle as these charge collectors, and, therefore, are amenable to a similar secondary electron suppression system in front of each collector.

For some applications, however, the emission of secondary electrons at the collector can be used to increase the analyzer signal-to-noise

ratio. The secondary coefficient γ must then be measured for an absolute calibration.

The secondary coefficient can be measured in such an ion species analyzer by splitting the collector into two equal parts as illustrated in Fig. 4. One half of the collector has the secondaries suppressed so that only the ion current is measured and in the other half the suppression tube is biased to collect the emitted secondaries. The secondary coefficient is the secondary current to the ion current ratio. This method of obtaining γ , especially when γ is large, should be much more precise than simply using a single collector and subtracting secondary current from the collector current because it does not involve a subtracting of two large and almost equal quantities. For $\gamma \leq 1$ the secondary current at the collector may be directly compared to the tube current to obtain γ without the need to split the collector system.

In summary, we have described a simple electrode geometry which eliminates secondary electrons or allows one to measure its secondary coefficients thereby expanding the versatility of direct charge collection diagnostics.

REFERENCES

1. A. W. Ehler, J. Appl. Phys. 46, 2464 (1975).
2. M. Oron and Y. Paiss, Rev. Sci. Inst. 44, 1293 (1973).
3. G. Charatis et al., "Plasma Physics and Controlled Nuclear Fusion Research 1974", Vol. II, 317 (IAEA, Vienna 1975).
4. B. H. Ripin, J. A. Stamper, E. A. McLean and F. C. Young, NRL Report #7838 (1974).
5. B. H. Ripin, Ph.D. thesis, Univ. of Md. Technical Report 71-038 (1970); See also, B. H. Ripin and R. E. Pechacek, Phys. Fluids 15, 1980 (1972).
6. R. Decoste and B. H. Ripin, Rev. Sci. Insts., 48, 232 (1977).
7. R. Decoste and B. H. Ripin, Bull. Am. Phys. Soc. 21, 1120 (1976), and submitted for publication (Appl. Phys. Lett.).

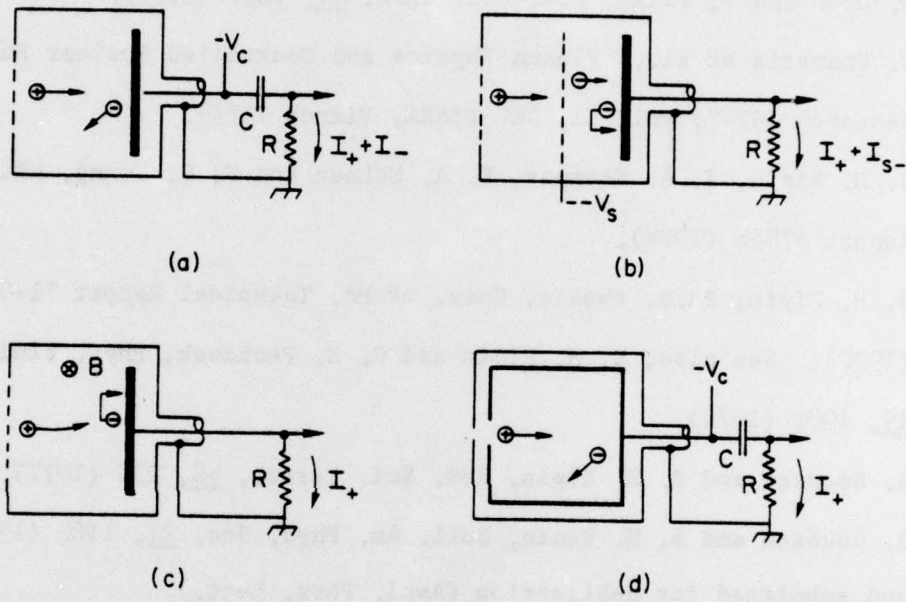

Fig. 1 — Typical ion charge collector arrangements with (a) no secondary suppression and with secondary suppression by (b) grids, (c) magnetic fields, and (d) Faraday cup

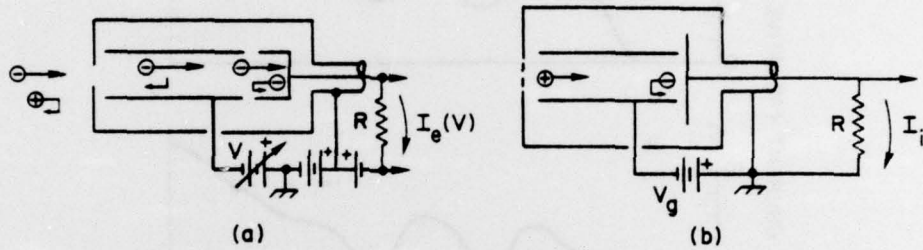

Fig. 2 — Particle analyzers with secondary electron suppression tube, (a) an electron energy analyzer and (b) an ion charge collector

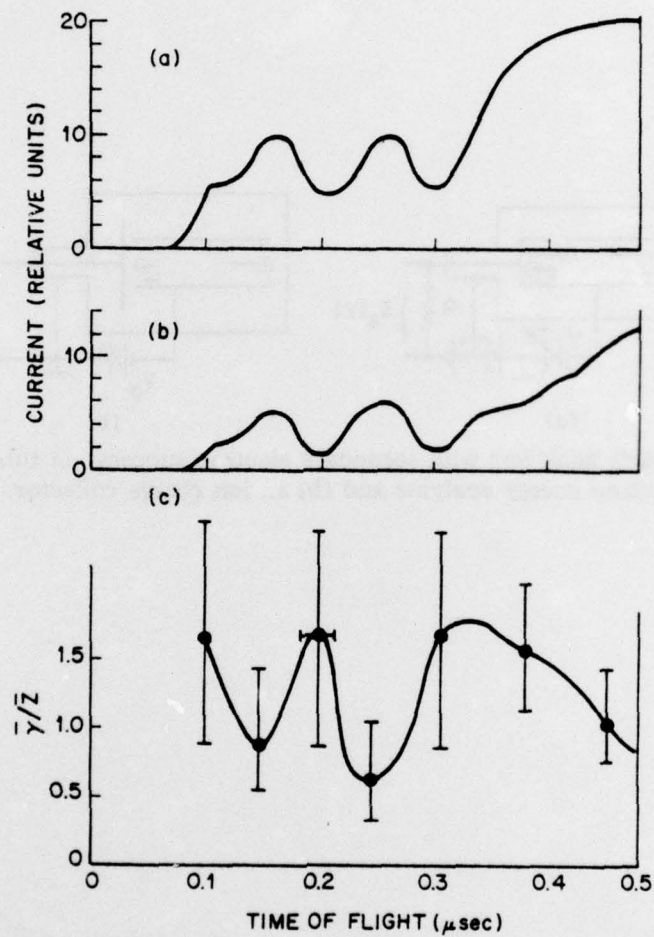

Fig. 3 — Comparison of the current vs time traces from two ion charge collectors with (a) no secondary suppression, and (b) with tubular secondary suppression. The ratio of the currents gives the average secondary coefficient $\bar{\gamma}$ shown in (c).

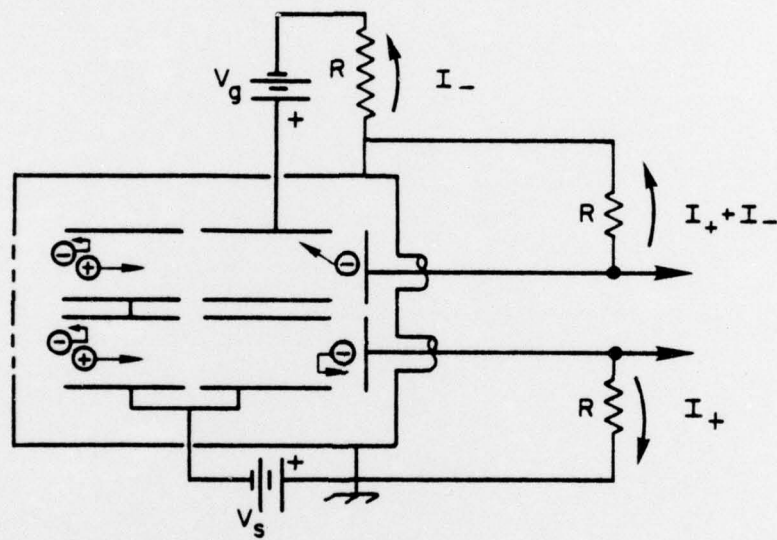

Fig. 4 - Split tubular charge collector system to measure γ when $\gamma \gg 1$