

AD-A040 345

CHEMICAL SYSTEMS LAB (ARMY) ABERDEEN PROVING GROUND MD F/G 11/1
A MAGNETIC-FLUID SEAL FOR MEASUREMENT OF AERODYNAMIC SURFACE PR--ETC(U)
APR 77 M C MILLER

UNCLASSIFIED

ARCSL-TR-77018

ED-TR-77019

NL

| OF |
AD
A040345



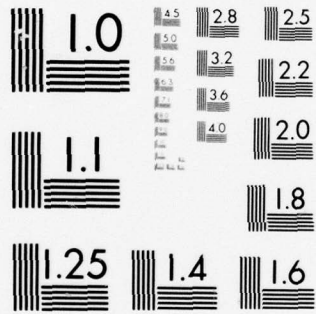

MICROCOPY RESOLUTION TEST CHART
NATIONAL BUREAU OF STANDARDS-1963-A

ADA 040345

AD
12

TECHNICAL REPORT ARC3L-TR-77018
(EO-TR-77019)

A MAGNETIC-FLUID SEAL FOR MEASUREMENT OF
AERODYNAMIC SURFACE PRESSURES

by

Miles C. Miller

Weapon Systems Concepts Team
Armament Concepts Office
ARRADCOM

April 1977

DDC
RECEIVED
JUN 9 1977
RECEIVED

go - D -

AD NO.
DDC FILE COPY



DEPARTMENT OF THE ARMY
US Army Armament Research and Development Command
Chemical Systems Laboratory
Aberdeen Proving Ground, Maryland 21010

Approved for public release; distribution unlimited.

Disclaimer

The findings in this report are not to be construed as an official Department of the Army position unless so designated by other authorized documents.

Disposition

Destroy this report when it is no longer needed. Do not return it to the originator.

UNCLASSIFIED

SECURITY CLASSIFICATION OF THIS PAGE (When Data Entered)

REPORT DOCUMENTATION PAGE		READ INSTRUCTIONS BEFORE COMPLETING FORM
1. REPORT NUMBER ARCSL-TR-77018	2. GOVT ACCESSION NO.	3. RECIPIENT'S CATALOG NUMBER
4. TITLE (and Subtitle) A MAGNETIC-FLUID SEAL FOR MEASUREMENT OF AERODYNAMIC SURFACE PRESSURE		5. TYPE OF REPORT & PERIOD COVERED Technical Report January 1976-July 1976
7. AUTHOR(s) Miles C. Miller		6. PERFORMING ORG. REPORT NUMBER ED TR-77019
9. PERFORMING ORGANIZATION NAME AND ADDRESS Director, Chemical Systems Laboratory Attn: DRDAR-ACW Aberdeen Proving Ground, Maryland 21010		8. CONTRACT OR GRANT NUMBER(s)
11. CONTROLLING OFFICE NAME AND ADDRESS Director, Chemical Systems Laboratory Attn: DRDAR-CLJ-I Aberdeen Proving Ground, Maryland 21010		10. PROGRAM ELEMENT, PROJECT, TASK AREA & WORK UNIT NUMBERS DA Project 1W662618AH80 ILIR Project 1T161101A91A
14. MONITORING AGENCY NAME & ADDRESS (if different from Controlling Office)		12. REPORT DATE April 1977
		13. NUMBER OF PAGES 35
		15. SECURITY CLASS. (of this report) UNCLASSIFIED
		15a. DECLASSIFICATION/DOWNGRADING SCHEDULE NA
16. DISTRIBUTION STATEMENT (of this Report) Approved for public release; distribution unlimited. Copies available from: National Technical Information Service, Springfield, Virginia 22151		
17. DISTRIBUTION STATEMENT (of the abstract entered in Block 20, if different from Report)		
18. SUPPLEMENTARY NOTES		
19. KEY WORDS (Continue on reverse side if necessary and identify by block number) Magnus effect Pressure measurement Sliding seal Magnetic-fluid seal		
20. ABSTRACT (Continue on reverse side if necessary and identify by block number) A magnetic-fluid sliding seal was designed, fabricated, and tested for application in a special instrumentation arrangement to measure the aerodynamic surface pressure on a spinning wind tunnel model. The seal was intended to provide a low-friction, airtight linear seal between stationary and rotating model components. A series of laboratory tests was conducted to evaluate the performance of the seal in relation to anticipated wind tunnel test conditions and possible model configurations. These tests involved measuring the maximum pressure that the (Continued on reverse side)		

UNCLASSIFIED

SECURITY CLASSIFICATION OF THIS PAGE(When Data Entered)

20. ABSTRACT (Contd)

seal was capable of holding at various model spin rates. The effects of certain seal parameters were investigated including: gap distance between stationary and moving components, magnetic-fluid properties (i.e., magnetization strength and viscosity), and ferrous versus nonferrous moving component material. These tests demonstrated that the seal was capable of holding a nominal pressure of 1 psi at a maximum sustained spin rate of 1250 rpm. This relates to a relative velocity between the moving and stationary components of 27 ft/sec. Higher pressures could be held at lower sustained spin rates and even under impulsive rotational conditions. The current seal design would appear to be applicable for this wind tunnel test technique where extremely low friction is required. However, it would be limited to spin rates under 1000 rpm. Design trends are indicated to increase the seal performance for future applications.

PREFACE

This effort was jointly funded by the AMC Ballistic Technology Program under DA Project 1W662618AH80, Research in Exterior Ballistics, and Edgewood Arsenal ILIR Project 1T161101A91A, Investigation of Magnus Surface Pressure Effects. The work described in this report was completed between January 1976 and July 1976.

The use of trade names in this report does not constitute an official endorsement or approval of the use of such commercial hardware or software. This report may not be cited for purposes of advertisement.

Reproduction of this document in whole or in part is prohibited except with permission of the Director, Chemical Systems Laboratory, Attn: DRDAR-CLJ-I, Aberdeen Proving Ground, Maryland 21010; however, DDC and the National Technical Information Service are authorized to reproduce the document for United States Government purposes.

Acknowledgment

I should like to acknowledge Mr. Jack Molnar and Mr. Owen Smith, Weapon Systems Concepts Team, Edgewood Arsenal, for their outstanding efforts in conducting the various tests described in this report.

I should also like to thank Mr. Dexter Howe, Ferrofluidics Corporation, for his excellent technical work in the analysis and design of the basic magnetic-fluid seal.

ACCESSION for	
NTIS	White Section <input checked="" type="checkbox"/>
DDC	Cuff Section <input type="checkbox"/>
UNANNOUNCED	<input type="checkbox"/>
JUSTIFICATION.....	
BY.....	
DISTRIBUTION/AVAILABILITY CODES	
SIC, AVAIL, and/or SPECIAL	
A	

DDC
RECEIVED
JUN 9 1977
D

CONTENTS

	<u>Page</u>
I. INTRODUCTION	7
II. BACKGROUND	8
III. SEAL DESCRIPTION	9
A. Physical Configuration	9
B. Magnetic Fluid	10
IV. EXPERIMENTAL EVALUATION	11
A. Testing Methodology	11
B. Parameters Investigated	11
C. Static Tests	12
D. Dynamic Tests	12
V. DISCUSSION OF RESULTS	13
VI. FUTURE DESIGN CONSIDERATIONS	14
VII. SUMMARY	15
VIII. CONCLUSIONS	15
GLOSSARY	17
APPENDIX, Figures	19
DISTRIBUTION LIST	33

PRECEDING PAGE BLANK - NOT FILMED

A MAGNETIC-FLUID SEAL FOR MEASUREMENT OF AERODYNAMIC SURFACE PRESSURES

I. INTRODUCTION.

This report describes an experimental evaluation of a sliding seal design which utilizes a magnetic fluid as the primary sealing element. The seal is intended to provide a low-friction, sliding seal between stationary and moving components of a wind tunnel model. The sealing element consists of a magnetic fluid, which is held in place by a magnetic field produced by a magnet contained within the seal mechanism. The magnetic fluid acts as a physical barrier to prevent the passage of air along the gap between the stationary and moving components of the model.

Sliding or rubbing seals are used for many applications in mechanical systems. They are usually in the form of a rubber flap or ring which is forced to stay in contact with the moving surface by means of springs, pneumatics, or its own material resilience. The combination of the frictional effect of the seal material, the pressing force necessary to effect a seal, and the relative velocity between the seal and the moving surface results in high frictional forces and eventual seal wear which may limit the functional performance of the mechanical device.

In the case of magnetic-fluid seals, however, only the fluid itself is in contact with the moving surface. Thus, the only frictional effect is due to viscous shear produced by the fluid in contact with the moving surface. This results in considerably lower friction than a mechanical seal device.

Magnetic-fluid seals have been developed for sealing between rotating shafts and their stationary housings.¹ For these applications, the sense of motion of the moving surface is essentially parallel to the line of contact between the magnetic-fluid seal and the moving surface. The magnetic-seal design considered in this report, however, is unique in that the relative motion of the moving surface is essentially normal (i.e., at right angles) to the line of contact between the magnetic-fluid seal and the moving surface. Also, in this instance, the surface possesses continuous (i.e., sustained) motion.

The magnetic-fluid seal evaluated in this study was designed specifically for use in an existing wind tunnel model. It was hoped that for this application the magnetic-fluid seal would provide adequate sealing with reduced friction as compared to the mechanical sliding seal originally used in the model.

The basic magnetic-fluid-seal configuration was conceived by the Weapon Systems Concepts Team. The Ferrofluidics Corporation, under contract to Edgewood Arsenal, completed the detailed design, fabrication, and initial functional testing.² Edgewood Arsenal then conducted a systematic experimental investigation of the effects of various seal configurational parameters relating to the wind tunnel model functional performance. This report documents the testing and results of this evaluation.

¹Rotary Seals Catalog Handbook. Ferrofluidics Corporation, Burlington, Massachusetts.

²Howe, Dexter S. Report on Linear Seal Development Program. Ferrofluidics Corporation. 31 December 1975.

II. BACKGROUND.

A new experimental technique has been evolved to measure the aerodynamic pressure distribution acting on the surface of a spinning wind tunnel model. The technique is based on the use of a two-part model with a nonspinning inner portion containing the pressure-measuring instrumentation and a spinning outer portion representing the aerodynamic surface. The feasibility of the technique was successfully demonstrated by a series of subsonic wind tunnel tests of a spinning right circular cylinder in crossflow. A complete description of the test arrangement and the results of the feasibility tests are contained in previous publications.^{3,4}

The details of the wind tunnel model are shown in figure A-1, appendix.* The model includes a stationary (i.e., nonspinning) cylindrical core. A thin-walled, cylindrical shell is located concentrically around the core and attached to the core by means of bearings located at each end. The shell is thus free to rotate or spin about the core and represents the external surface of the spinning model body. A pressure tap is located in the core at midspan and oriented radially outward toward the point on the external surface of the shell at which the pressure is being measured. A small vent hole is located through the shell at midspan, so that it will line up with the face of the pressure tap once every revolution of the shell about the core.

The gap between the face of the pressure tap and the inner surface of the shell is sealed in all directions (i.e., longitudinally and circumferentially) by means of a circular seal located around the face of the pressure tap. The cavity created within this seal will be open to the pressure acting on the outside surface of the shell when the vent hole is aligned with the tap. Once the vent hole has rotated past this aligned position, the seal will cause the cavity to retain the pressure. After several revolutions of the spinning shell, the cavity will eventually assume a constant pressure with time, equal to the pressure acting on the surface of the spinning model at that particular circumferential location. Pressure measurements at various points on the surface of the spinning model can be obtained by positioning the core and attached pressure tap at different attitudes to the airflow. This is accomplished by simply rotating the core about its longitudinal axis to a particular angle and holding it there sufficiently long to obtain the pressure measurement.

Sealing of the cavity around the face of the stationary pressure tap and the rapidly moving shell is the key factor for the success of this testing technique. As shown in figure A-1, the model utilized in these tests included a mechanical sliding seal arrangement. The brass pressure tap was held in the model core by means of a cylindrically-shaped Teflon seal block whose outer surface was shaped to match the inner contour of the shell. The outer surface of the seal block included a circular groove into which a circular rubber O-ring washer was placed. Springs located within the seal assembly pressed the rubber O-ring against the inside surface of the shell.

*All other figures are in the appendix.

³Miller, Miles C. EA-TR-76070. A Technique to Measure the Pressure Distribution Acting on the Surface of a Spinning Body in a Wind Tunnel. September 1976.

⁴Miller, Miles C. Surface Pressure Measurements on a Spinning Wind Tunnel Model. pp 1669-1670. AIAA Journal. December 1976.

Model spin was achieved by means of a 2-hp electric motor located outside the tunnel test section which was attached to the model by a drive shaft/pulley arrangement as illustrated in figure A-2, which illustrates the general wind tunnel model installation and instrumentation arrangement.

The model also included an internal mechanism which continuously deposited silicone grease onto the inner shell surface and rubber O-ring during the wind tunnel test to aid in lubrication and sealing. A seal spring force of 8 pounds was required to provide an adequate seal. Using this arrangement, pressure measurements as high as 0.8 psi were successfully obtained at maximum model spin rates of 8000 rpm (the predetermined goal).

The ultimate objective was to use the testing technique to measure the surface pressure distribution on an autorotating body. It was planned to convert the existing wind tunnel model to that of a cylindrical autorotor by merely adding four longitudinal driving vanes to the shell. For these tests, it was hoped that the model would spin by its own aerodynamic autorotation moment without requiring any external power means. This would necessitate an extremely low-friction seal. Model spin rates of about 2000 rpm are considered typical for this type of test.

A magnetic-fluid-type seal appeared to offer a potential means of providing the seal performance required. Because of the new and unique nature of the seal design and its unusual application, complete analytical seal performance predictions were not possible. Accordingly, the initial seal design was installed in the model and experimentally evaluated under controlled laboratory conditions. These tests were intended to establish the seal performance limits for eventual application in actual wind tunnel tests.

III. SEAL DESCRIPTION.

A. Physical Configuration.

The basic configuration of the seal is illustrated in figure A-3. A toroidal-shaped permanent magnet is oriented and positioned in the model core near the inner surface of the moving shell. The magnet is polarized so that the inner region is one polarity (i.e., north) and the outer region is the opposite polarity (i.e., south). The magnetic field produced by the magnet is directed and concentrated by means of inner and outer concentric pole blocks made of conductive material. The extension of these blocks in the direction of the moving surface converge but do not touch so that their separation is small. Also, the tips of these blocks approach, but do not come in contact with, the moving surface. The resulting magnetic-field path through the system is indicated by arrows.

A magnetic fluid consists of a colloidal suspension of ferrite particles in a carrier liquid. The resulting magnetic fluid is affected by a magnetic field as if it were a ferrous material but it retains the chemical and mechanical characteristics of the carrier liquid. A variety of carrier liquids can be utilized ranging from hydrocarbons to water depending on the specific application.

When the magnetic fluid is placed in the gap between the tips of the pole blocks, the concentrated magnetic field will form the fluid into a ring form. The concentrated field at the confluence area of the pole block tips and the surface will act to hold the magnetic fluid in

a ring form, even in the presence of the moving surface. The fluid ring will contact the moving surface in a circular line. The fluid thus forms a linear barrier preventing the transmission of air between the cavity within the fluid ring (denoted as pressure P) and the region outside of the fluid ring denoted by pressure P_0 . The pressure differential held by the seal is $\Delta P = P - P_0$. In effect, the fluid serves the same function as a rubber O-ring. However, the magnetic-fluid seal only produces friction through viscous shear between the fluid and the moving surface. This friction force is several orders of magnitude less than that of a rubber O-ring seal. Note that a substantial portion of the ring-shaped seal is providing a linear seal element which is essentially normal to the motion sense of the moving surface. This feature differentiates this magnetic-fluid-seal configuration from any previously designed or tested.

The specific seal designed and fabricated for this application is shown in figure A-4. The magnet element was composed of eight rectangular samarian cobalt permanent magnets arranged to form a hollow cylinder. The strength or flux density of this magnet was about 8000 gauss. The magnet was concentrically encased between a cylindrical steel inner pole block and a cylindrical steel outer pole block. The inner pole block also served as the pressure tap and contained the cavity region and a central hole by which the pressure in the cavity could be transmitted out of the model to monitoring instrumentation. The inner pole block, outer pole block, and magnet were held in place by an aluminum housing. The outer tips of the concentric pole blocks converged toward each other resulting in a minimum separation of 0.034 inch. Figure A-5, A, shows the seal components and figure A-5, B, shows the fully assembled seal configuration.

During actual wind tunnel testing, a certain amount of magnetic fluid could be forced out through the shell vent hole by the centrifugal action of the spinning shell. The seal design included a means of replacing this fluid loss from a reservoir within the model. This was simply composed of an inlet tap into the back side of the seal through which the fluid could flow past the magnet to the tip of the seal. Thus, the fluid would be drawn from the reservoir as needed.

B. Magnetic Fluid.

A magnetic fluid consists of a colloidal suspension of ferrite particles in a carrier liquid. The ferrite particles measure about 0.5 micron in diameter and are treated with a special agent to prevent coagulation. The magnetic fluid is simply placed on the area between the outer tips of the pole blocks. The concentrated magnetic field in this region causes the fluid to form into a circular ring. This ring will be held in place regardless of the orientation and motion of the seal. The size of the ring depends on the amount of fluid used. Typically the fluid ring measures 0.45 inch in diameter and has a ring thickness of about 0.125 inch. Figure A-6 contains a photograph of the seal both before and after the fluid is added.

The magnetic fluid utilized in this study used a diester-based carrier fluid and was obtained commercially from the Ferrofluidics Corporation. Four different types of magnetic fluids (commercially designated "Ferrofluids") were evaluated, representing different magnetization and viscosity characteristics. The physical properties of the fluids tested are summarized below:

<u>Ferrofluidic Corporation designation</u>	<u>Magnetization M</u>	<u>Viscosity μ</u>	<u>M/μ</u>
	gauss	centipoise	$\frac{\text{gauss}}{\text{centipoise}}$
F236G	1000	520	1.92
F236F	800	95	8.42
F236D	600	27	22.0
F236E	400	6	66.0

IV. EXPERIMENTAL EVALUATION.

A. Testing Methodology.

The magnetic-fluid seal was evaluated in the same wind tunnel model used for the earlier feasibility tests of the wind tunnel testing technique. The entire seal assembly was placed in the radial hole of the wind tunnel model core as shown in figure A-7. Figure A-8 illustrates the general seal installation and defines the various test parameters. The seal radial position could be adjusted by shimming to provide a specific gap distance between the outer tips of the pole blocks and the inner surface of the rotating model shell. During testing, this gap (ϵ) could be varied between a minimum distance of 0.005 inch to a maximum distance of 0.040 inch. With the seal located in the core and the fluid added to the seal, the shell was slid down around the core onto its bearings and locked into place. The physical presence of the shell tended to flatten out the fluid ring because of the reduced gap size.

For these tests, the model was mounted outside of the tunnel so that its spin axis could be placed in either a vertical or a horizontal attitude. Also, when testing in a horizontal attitude, the model core could be oriented so that the seal was located at either the top, side, or bottom in order to evaluate the effect of gravity on the seal performance.

The model vent hole was plugged with red wax and a tape band was placed around the outer surface of the shell to hold the wax in place. A positive pressure was then established within the seal cavity by means of a controlled air compressor. The pressure was monitored by means of a manometer tube. Model spin was provided by a 1/2-horsepower, variable-speed electric motor. A magnetic tachometer was used to measure the shell spin rate. The test arrangement and associated instrumentation are shown in figure A-9.

The test procedure was to arrange the seal and model to the particular configuration desired, pressurize the seal cavity to the test pressure, and increase the model spin rate incrementally until the seal could no longer hold the pressure.

B. Parameters Investigated.

The basic seal was specifically designed for inclusion in the existing wind tunnel model. Thus, the arrangement and dimensions were constrained by this requirement. The seal permanent magnet configuration, pole block shaping, and pole block tip separation dimensions

were established through a combination of analytical and iterative tests conducted by the contractor as described in a previous publication.² During the evaluation conducted at Edgewood Arsenal, the following parameters (as defined in figure A-8) were investigated:

<u>Parameters</u>	<u>Symbol</u>
Differential pressure	ΔP
Magnetic-fluid magnetization strength	M
Magnetic-fluid viscosity	μ
Gap dimension between moving and stationary surface	ϵ
Model spin rate	ω
Moving surface material	Aluminum or steel

C. Static Tests.

Initial tests were conducted to evaluate the magnetic-fluid seal performing under static conditions (i.e., shell not rotating). For these tests, a diester-based Ferrofluid was used having a magnetization of 1000 gauss and a viscosity of 520 centipoise. The test procedure was to increase the pressure in the cavity region of the seal with air until the seal leaked.

An initial series of tests was conducted with the model oriented in both a horizontal and a vertical attitude so that the magnetic seal could be evaluated at various attitudes to the vertical. No influence due to the seal orientation relative to the vertical (i.e., the gravity field direction) was present. Also, with the model spin axis oriented vertically, the magnetic-fluid film deposited on the inner shell surface tended to run slowly down the inside of the shell and into the lower bearing housing. This did not affect the seal characteristics but it necessitated cleaning the bearing with consequent loss of magnetic fluid. Thereafter, in order to avoid these problems, all tests were conducted with the model spin axis in a horizontal attitude, with the seal located on the top side.

Figure A-10 indicates the maximum pressure held as a function of seal-to-shell gap distance. Both a steel shell (which conducts the magnetic field) and an aluminum shell (which does not conduct the magnetic field) were evaluated. Note that the conducting steel shell resulted in the seal having about twice the pressure capability as the nonconducting aluminum shell. Also, the sealing performance increased as the gap distance was decreased. During these tests, the shell could be manually rotated up to 100 rpm or impulsively rotated back and forth without affecting the ability of the seal to hold the pressure.

D. Dynamic Tests.

The next series of tests was conducted to evaluate the seal performance with the shell spinning rapidly (i.e., representing a sustained moving surface). These tests consisted of pressurizing the seal cavity and increasing the rotation rate of the shell until the seal leaked as indicated by the loss of pressure in the cavity. The results of these tests are summarized in figure A-11 which shows the maximum spin rate achieved with the seal holding a specific

pressure for various values of gap distance. A Ferrofluid having a magnetization of 800 gauss and a viscosity of 95 centipoise was used in these tests.

A final series of dynamic tests was conducted to assess the seal performance using magnetic fluids having different magnetization and viscosity characteristics. The results of these tests are shown in figure A-12, which indicates the maximum spin rate achieved with the seal holding a 1 lb/in² pressure for different gap distances and magnetic fluids. A pressure of 1 psi was considered nominal because it represents the maximum pressure present during subsonic wind tunnel tests of this particular model. These data indicate that the dynamic performance of the seal is a function of both the magnetization and the viscosity of the magnetic fluid. For the diester-based magnetic fluid used, the magnetization strength M and the viscosity μ are interrelated. Thus, it is not possible to determine the separate effect of each term on the seal performance. This effect could only be evaluated by testing a magnetic fluid with the same M/μ ratio but with different absolute values of M and μ as the diester fluid used in these tests.

V. DISCUSSION OF RESULTS.

A more basic and meaningful measure of the performance of the magnetic-fluid seal is the actual relative velocity between the seal and the moving surface. Since the inner surface of the shell has a radius of 2.46 inches from the axis of rotation, the velocity of the inner shell surface (i.e., the moving surface) relative to the stationary seal can be easily calculated. The relative seal/shell velocity for the various data presented can be obtained from the curve in figure A-13. In addition, the maximum seal-performance condition achieved with this seal is denoted on this curve. The current seal was capable of holding a pressure of 1 psi at a spin rate of 1250 rpm corresponding to a relative velocity of 27 ft/sec. It should also be noted that there was no discernible friction due to the seal during any of the dynamic tests.

In both static and dynamic tests, the seal either held the pressure without any leaking or would fail completely with an instantaneous loss of pressure. A thin layer of magnetic fluid was formed on the inside surface of the shell which passed over the seal. After a spin rate was achieved where the seal failed, the spin was reduced and the seal usually reformed at a lower spin rate. If the seal did not reform, inspection of the seal indicated that insufficient magnetic fluid remained to form a ring.

Evidently, at a particular spin rate, the viscous shear between the magnetic fluid ring and the layer of fluid on the moving surface became so great that it simply tore the ring apart and spread it to either side of the track. Based on this reasoning, it would appear that a low-viscosity carrier fluid would improve the seal performance. However, the absolute magnetization strength must also be as large as possible.

Finally, a combination mechanical- and magnetic-fluid sliding seal was evaluated. It was reasoned that, if a scraper were added to the tip of the magnetic-fluid seal, it might improve the seal performance by reducing the effects responsible for breaking down the fluid ring. Accordingly, the seal was modified to include a rubber O-ring located concentrically around the fluid ring so that a rubber ring was in light contact with the inside surface of the shell. The forward (upstream) side of the rubber ring would act to push the layer of magnetic fluid on the shell to either side of the magnetic-fluid ring, thus reducing the fluid layer height and its impact force on the fluid ring. Secondly, the aft (downstream) side of the rubber O-ring would act to both support and scrape up the fluid ring. This modified seal is shown in figure A-14.

Tests were conducted with this combination under the following sequence: (1) pure fluid seal, (2) pure rubber O-ring seal, and (3) combination of (1) and (2).

In order to be effective, in combination (3), the rubber O-ring had to be pressed against the shell with considerable force. This was achieved by shimming the seal assembly outward. Under these conditions, the combination of the magnetic fluid and the rubber O-ring held a pressure of 9 psi at 3000 rpm (which were the maximum conditions possible with the test arrangement). However, the same pressure/spin conditions were held with the rubber O-ring alone as indicated below:

<u>Configuration</u>	<u>P</u> psi	<u>ω</u> rpm
Magnetic fluid alone*	1	750
Rubber O-ring alone	9	3000
Magnetic fluid with rubber O-ring	9	3000

*M = 800 gauss; μ = 95 centipoise; ϵ = 0.02 inch.

It should be noted that these tests were conducted with the model spin axis in a vertical attitude. During the tests with the magnetic-fluid seal alone, the magnetic fluid tended to run down the inside of the shell surface. After the tests with the combination magnetic/mechanical seal, it was found that the vacuum grease from the rubber O-ring formed a ridgelike track on the inner shell surface which acted to prevent the magnetic fluid from running down. After these particular tests, no fluid appeared to be lost.

The frictional force of the various seal combinations was not measured during these tests. It cannot be determined, therefore, whether the combination of the magnetic fluid and rubbing seal resulted in less friction than the rubbing seal alone. Additional tests will have to be conducted to qualify this effect. Based on the overall test results, the magnetic-fluid-seal design evaluated does not have the sealing performance required for the 2000 rpm autorotor wind tunnel tests. However, it appears to be capable of being used for tests at spin rates under 1000 rpm.

VI. FUTURE DESIGN CONSIDERATIONS.

The purpose of this study was to evaluate the performance capability of the baseline magnetic-fluid seal. As a result of the design analysis and test data, certain design trends are indicated to improve the seal performance for future applications.

A major improvement could be realized by increasing the strength of the seal magnet. The magnet contained in the current seal was composed of several rectangular magnets formed into a ring. The strength of this arrangement could be increased by shaping the magnets to fit together better by use of a larger single permanent magnet or even an electromagnet.

The use of a magnetic fluid having a higher absolute magnetization strength and a lower absolute viscosity would also appear to increase the seal performance.

Other changes which might improve the seal performance for this application include: reducing the vent hole diameter, eliminating the vent hole edge radius on the inner surface of the shell, increasing the number of concentric pole block tip stages, and increasing the width of each tooth (tip edge). Finally, a combination mechanical- and magnetic-fluid sliding seal could be investigated further.

VII. SUMMARY.

A magnetic-fluid sliding seal was designed, fabricated, and tested for application in a special instrumentation arrangement to measure the aerodynamic surface pressure on a spinning wind tunnel model. The seal was intended to provide a low-friction, airtight linear seal between stationary and rotating model components. A series of laboratory tests was conducted to evaluate the performance of the seal in relation to anticipated wind tunnel test conditions and possible model configurations. These tests involved measuring the maximum pressure that the seal was capable of holding at various model spin rates with regard to the following parameters: (1) gap distance between stationary and moving components, (2) magnetic fluid properties (i.e., magnetization strength and viscosity), and (3) ferrous and nonferrous moving component materials.

These tests demonstrated that the seal was capable of holding a nominal pressure of 1 psi at a maximum sustained spin rate of 1250 rpm. This relates to a relative velocity between the moving and stationary components of 27 ft/sec. Higher pressure could be held at lower sustained spin rates and even under impulsive rotational conditions.

Seal performance was improved by reducing the gap dimension, increasing the magnetization strength of the magnetic fluid, reducing the viscosity of the magnetic fluid, and using a ferrous-material moving component.

The current seal design would appear to be applicable for this wind tunnel test technique where extremely low friction is required. However, it would be limited to spin rates under 1000 rpm. The magnetic-fluid seal evaluated during this study represents the first attempt at a seal of this type and it has provided a base-line design in future improvements as noted in the report.

VIII. CONCLUSIONS.

1. The basic magnetic-fluid seal evaluated in this study can provide a low-friction, sliding seal for application to the special surface pressure measuring wind tunnel testing technique at relatively low pressures (<1 psi) and low spin-rate (<1000 rpm) conditions. It can thus be utilized for Magnus-related surface pressure studies on relatively slowly rotating aerodynamic configurations such as missiles, mortars, and re-entry vehicles.

2. Data resulting from this study indicate design trends for increasing the performance capability of the magnetic-fluid seal for wind tunnel testing applications involving higher pressure and spin-rate conditions.

3. This type of seal can provide a virtually frictionless sliding linear seal while in contact with a rapidly moving surface which is translating essentially normal to the line of contact between the seal and the moving surface. The general seal configuration would appear to have application in a variety of instruments and mechanical devices which have requirements for a sliding seal having virtually no friction or wear for both a multidirectional impulsively or sustained moving surface.

GLOSSARY

d	Outside diameter of model shell
M	Magnetization strength of magnetic fluid
P	Pressure in seal cavity
P _O	Pressure outside seal cavity
P _S	Surface pressure on model shell
P _∞	Free-stream static pressure
ΔP	Pressure differential across seal ($\Delta P = P - P_O$)
R	Radius of inner shell surface
V _R	Relative velocity between moving surface and magnetic-fluid ring ($V_R = R\omega$)
V _∞	Free-stream velocity
ε	Gap dimension between top of stationary seal and moving surface
ρ _∞	Free-stream air density
ω	Shell spin rate
μ	Viscosity of magnetic fluid

PRECEDING PAGE, BLANK, NOT FILMED

APPENDIX

FIGURES

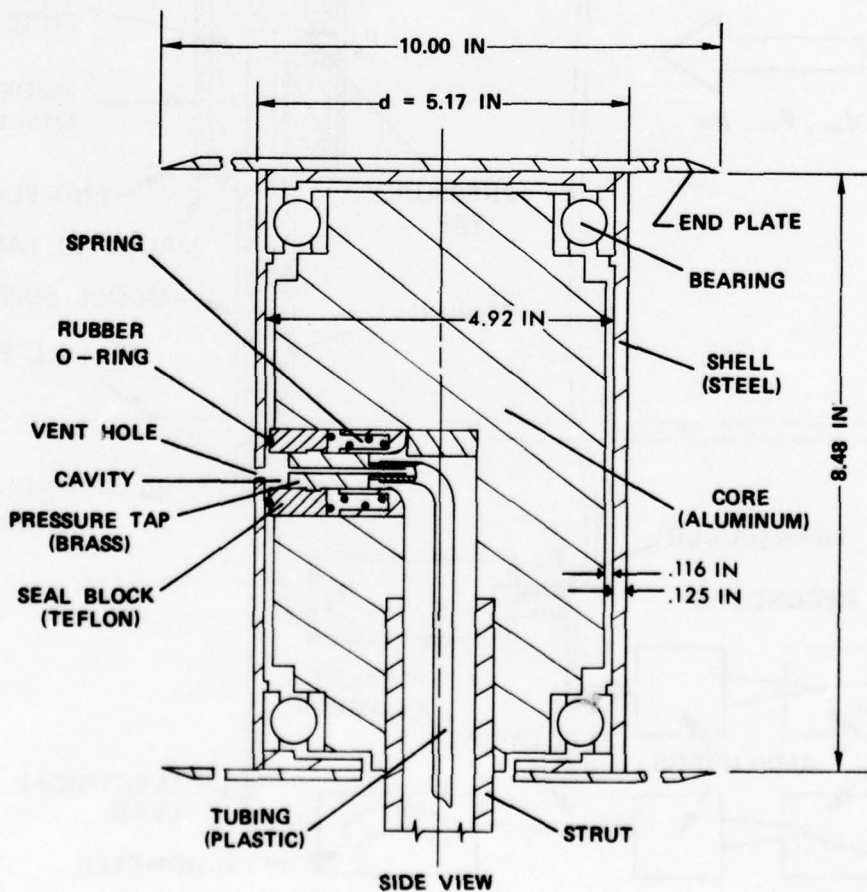
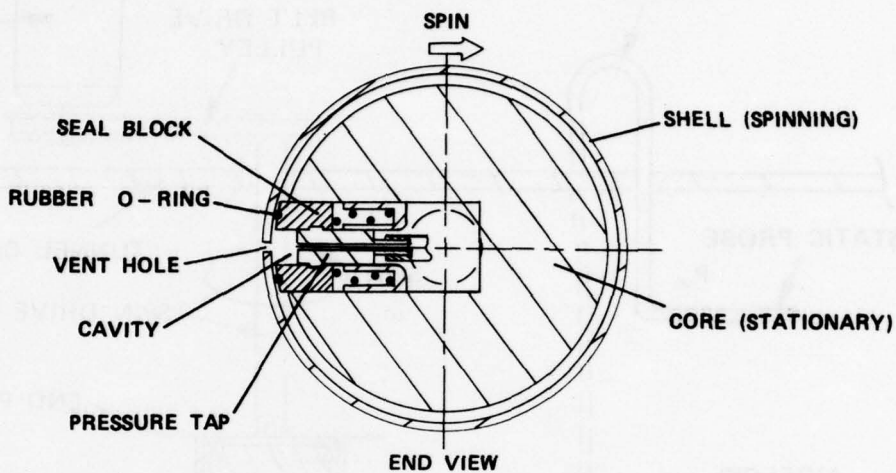

Figure A-1. Wind Tunnel Model

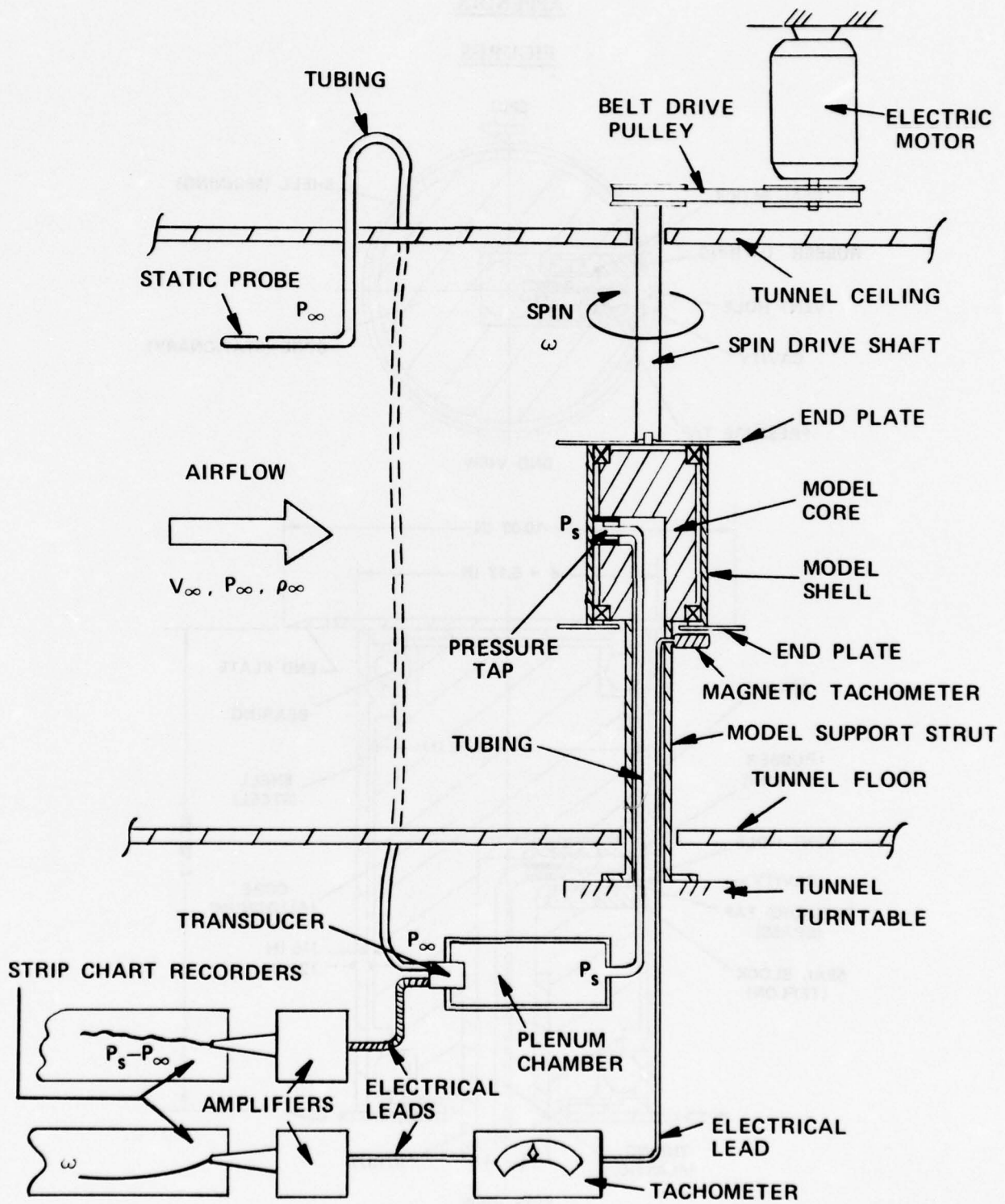

Figure A-2. Wind Tunnel Installation and Instrumentation

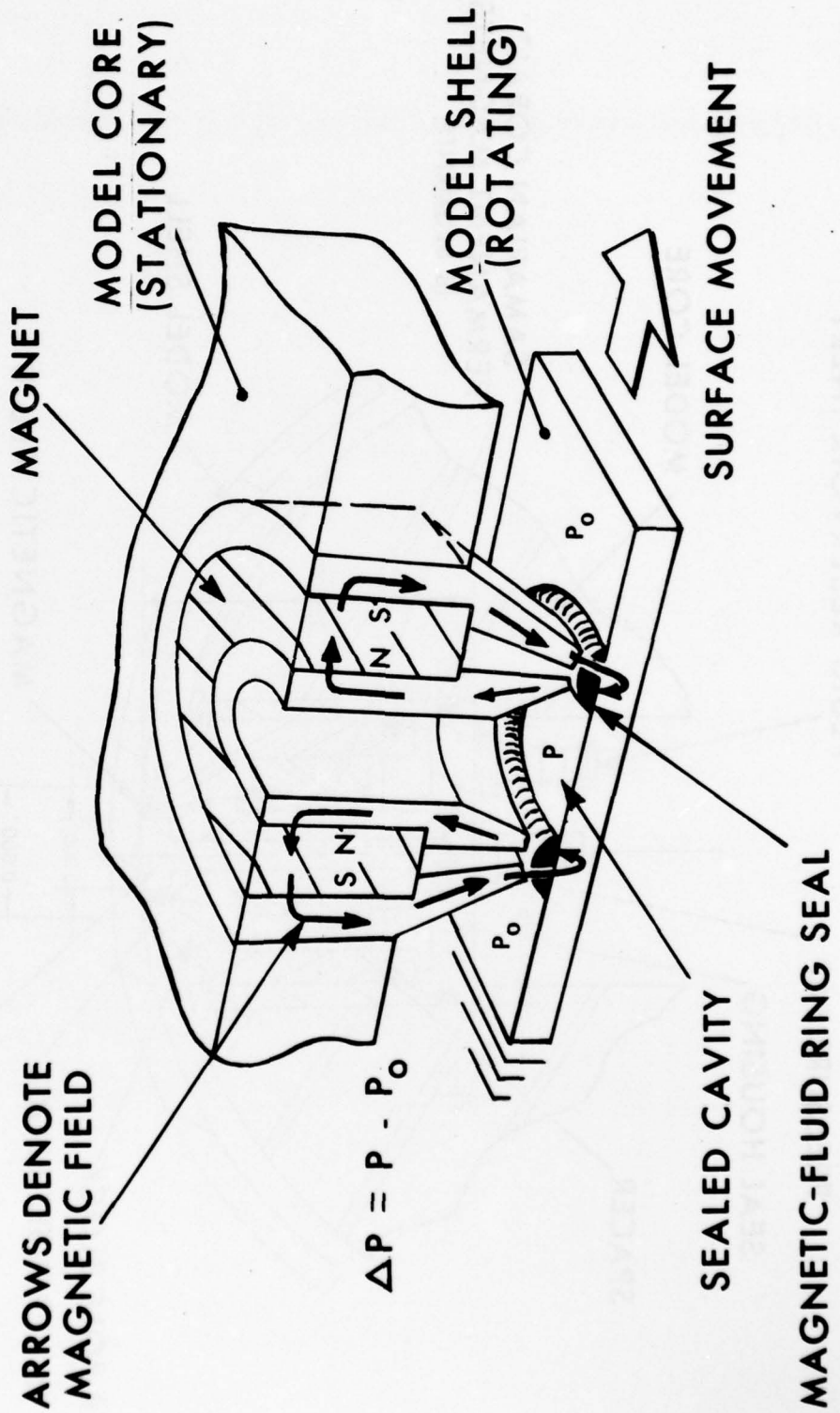

Figure A-3. Magnetic-Fluid Sliding-Seal Concept

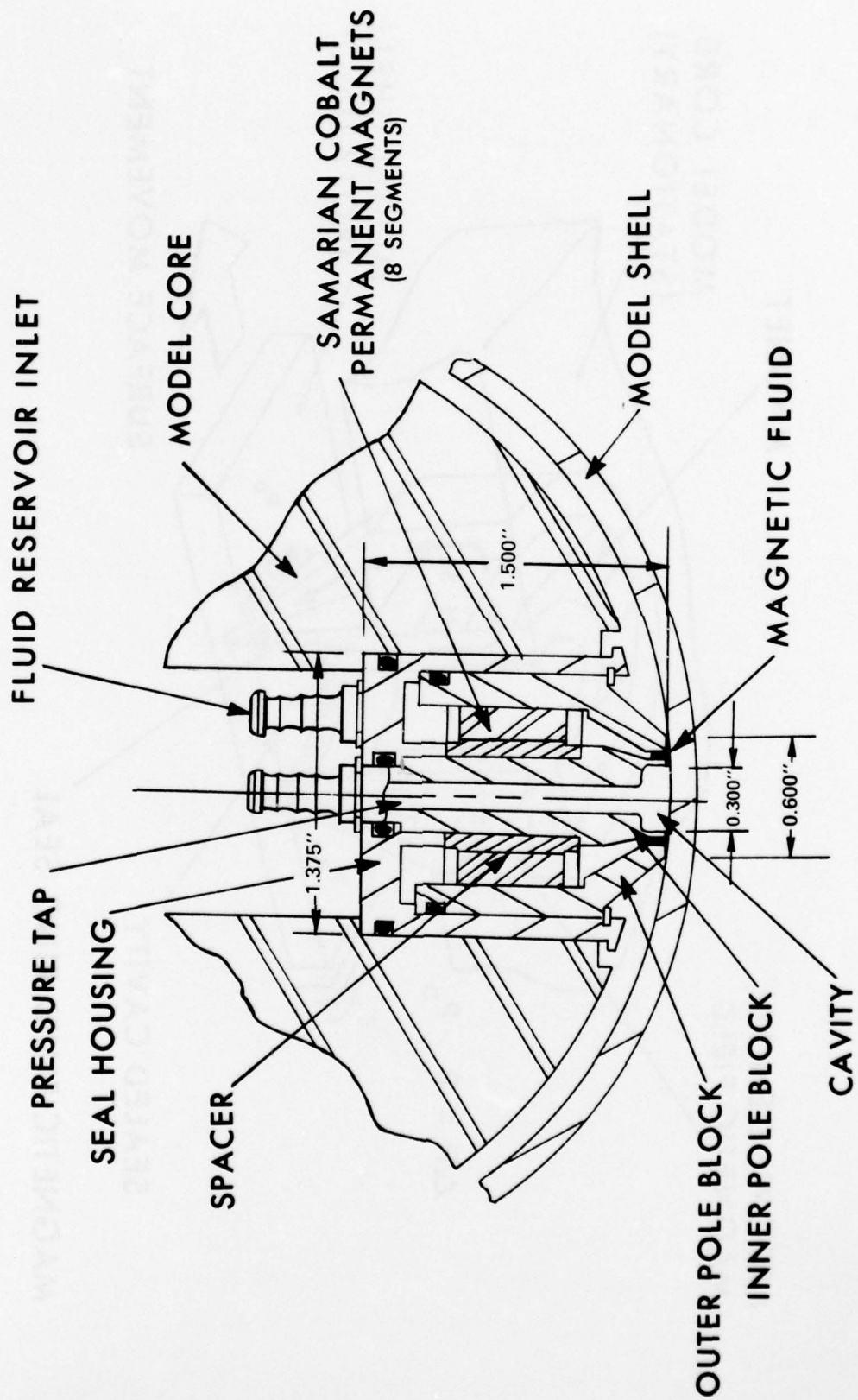
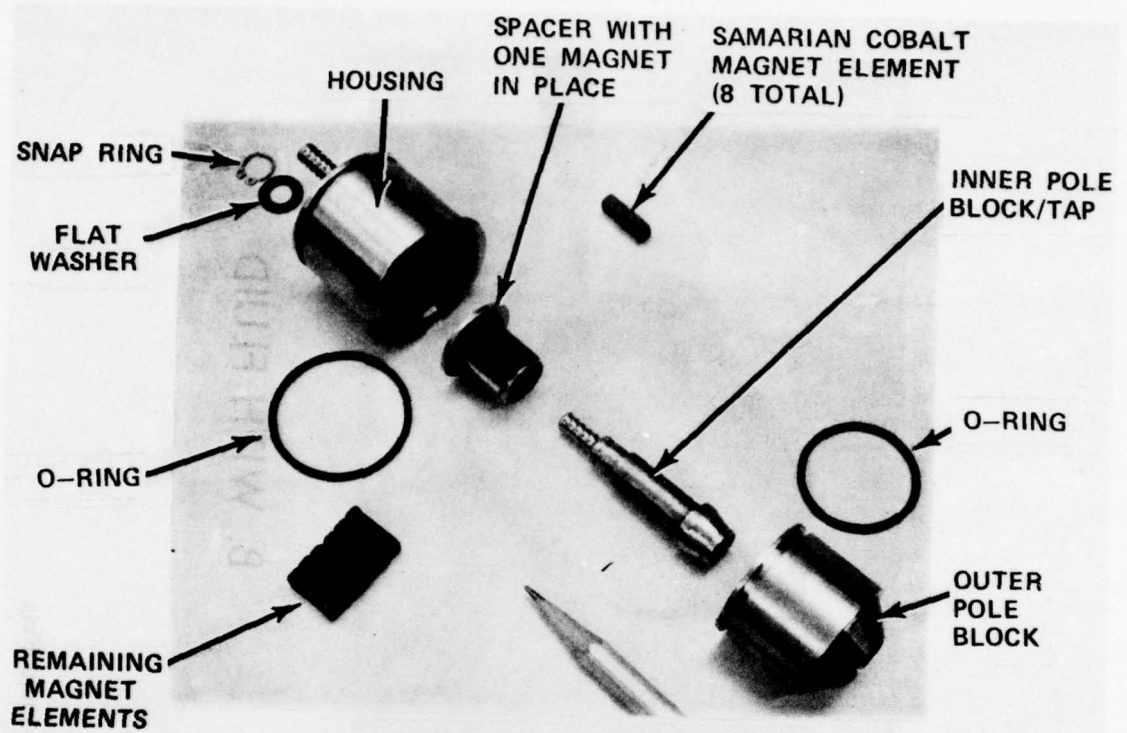
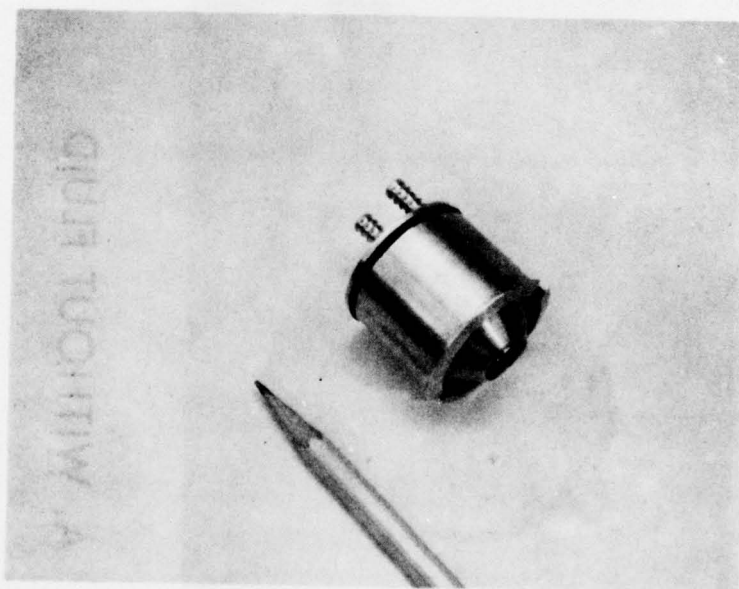

Figure A-4. Magnetic-Fluid Sliding-Seal Configurational Details



A. SEAL COMPONENTS



B. ASSEMBLED CONFIGURATION

Figure A-5. Magnetic-Fluid Sliding Seal

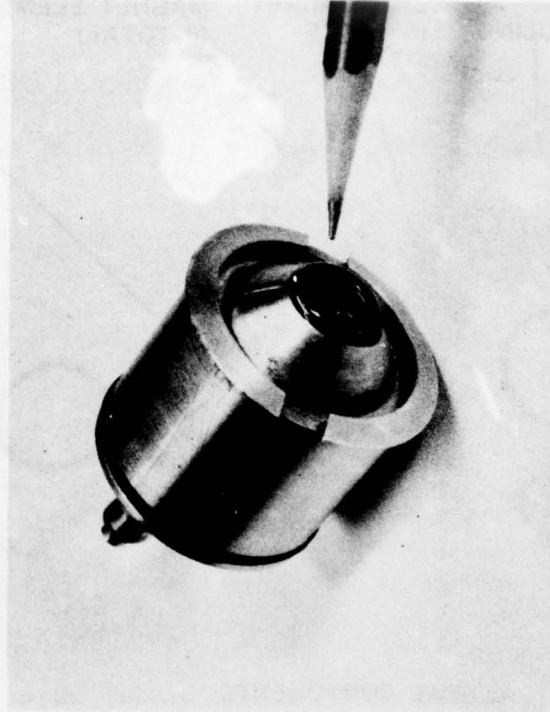

B. WITH FLUID

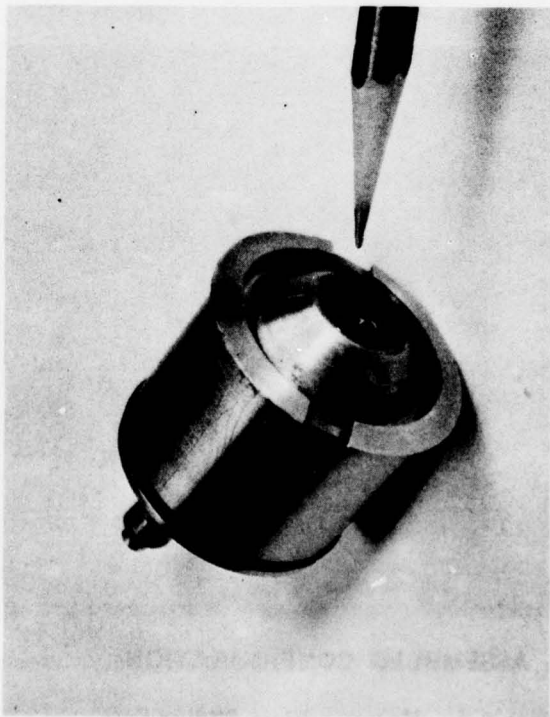

A. WITHOUT FLUID

Figure A-6. Magnetic-Fluid Ring

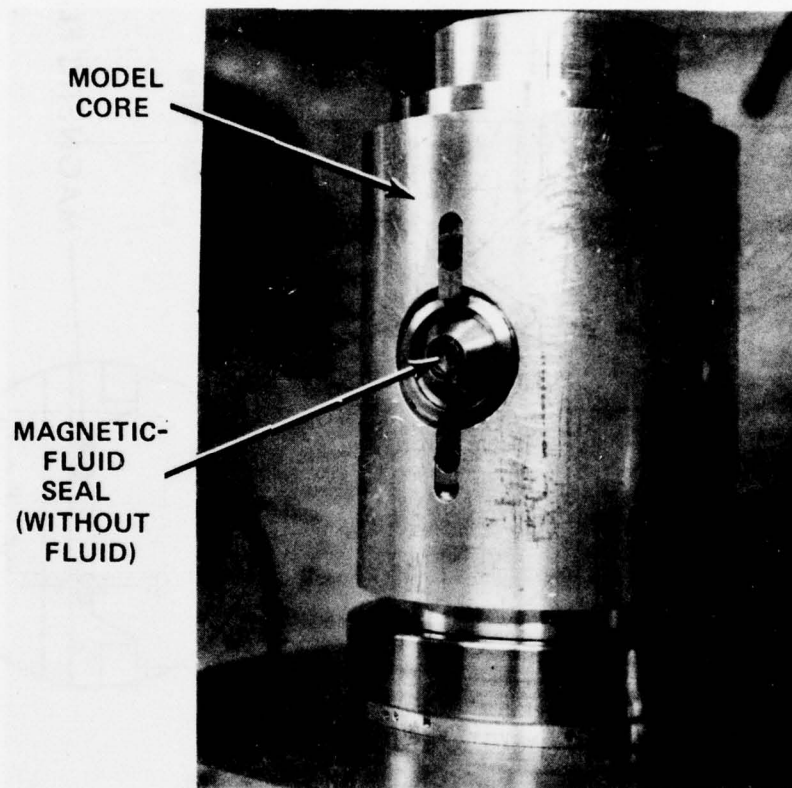

Figure A-7. Magnetic-Fluid Seal Installed in Wind Tunnel Model

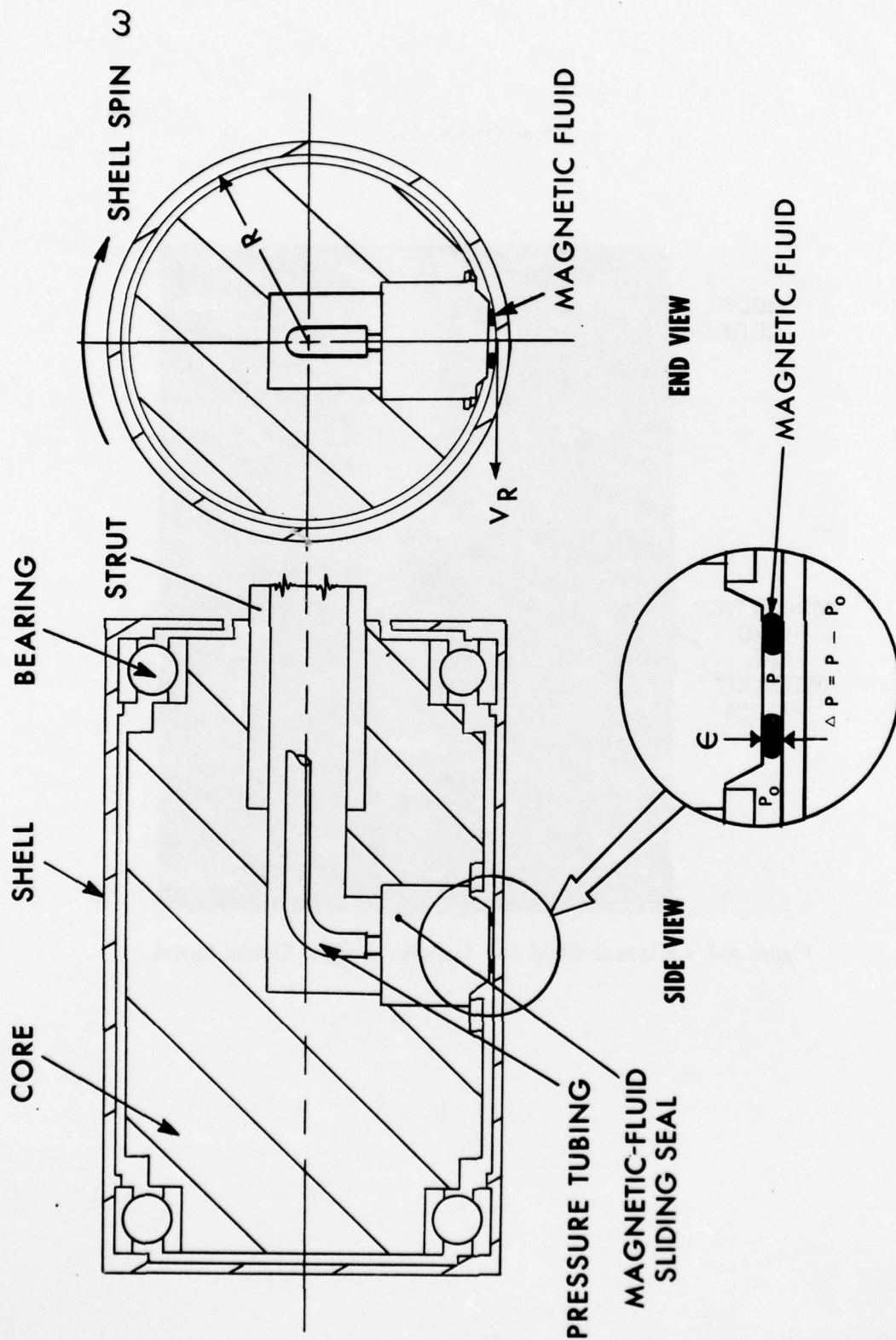

Figure A-8. Seal Installation and Parametric Terms

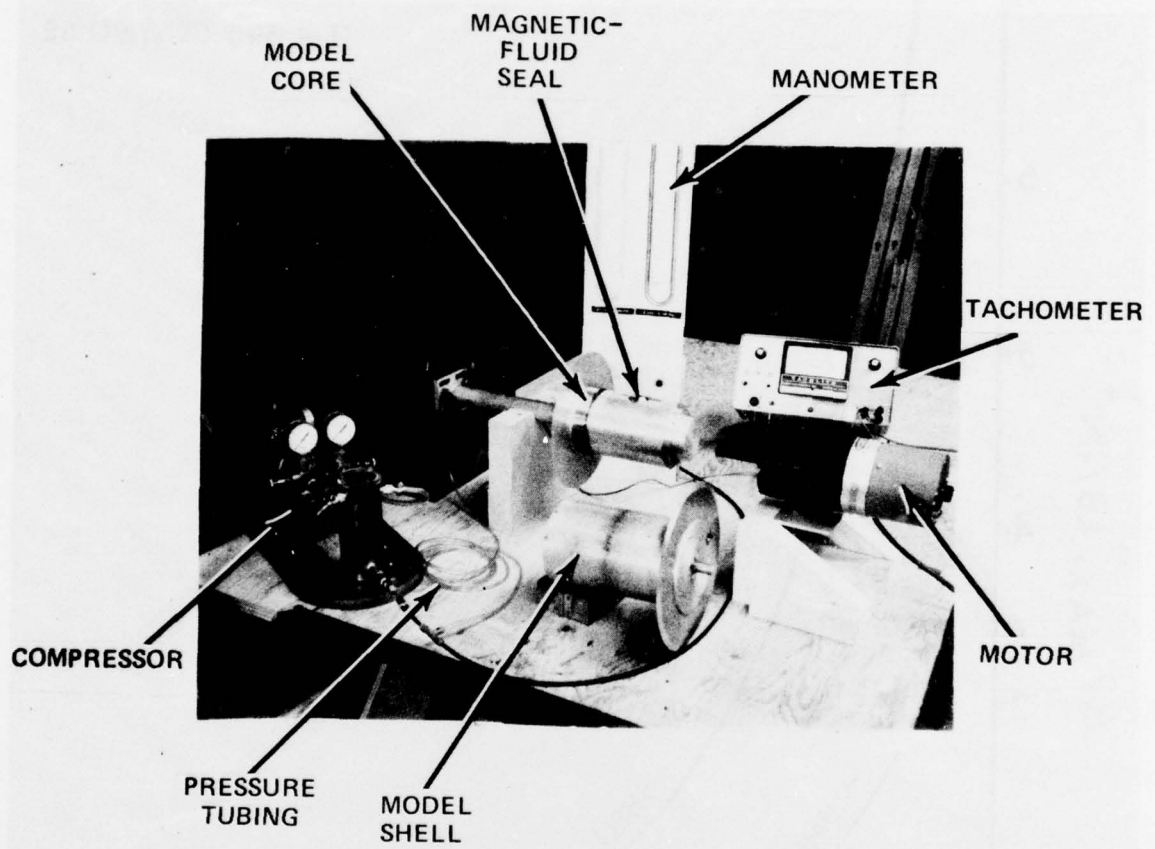

Figure A-9. Test Arrangement

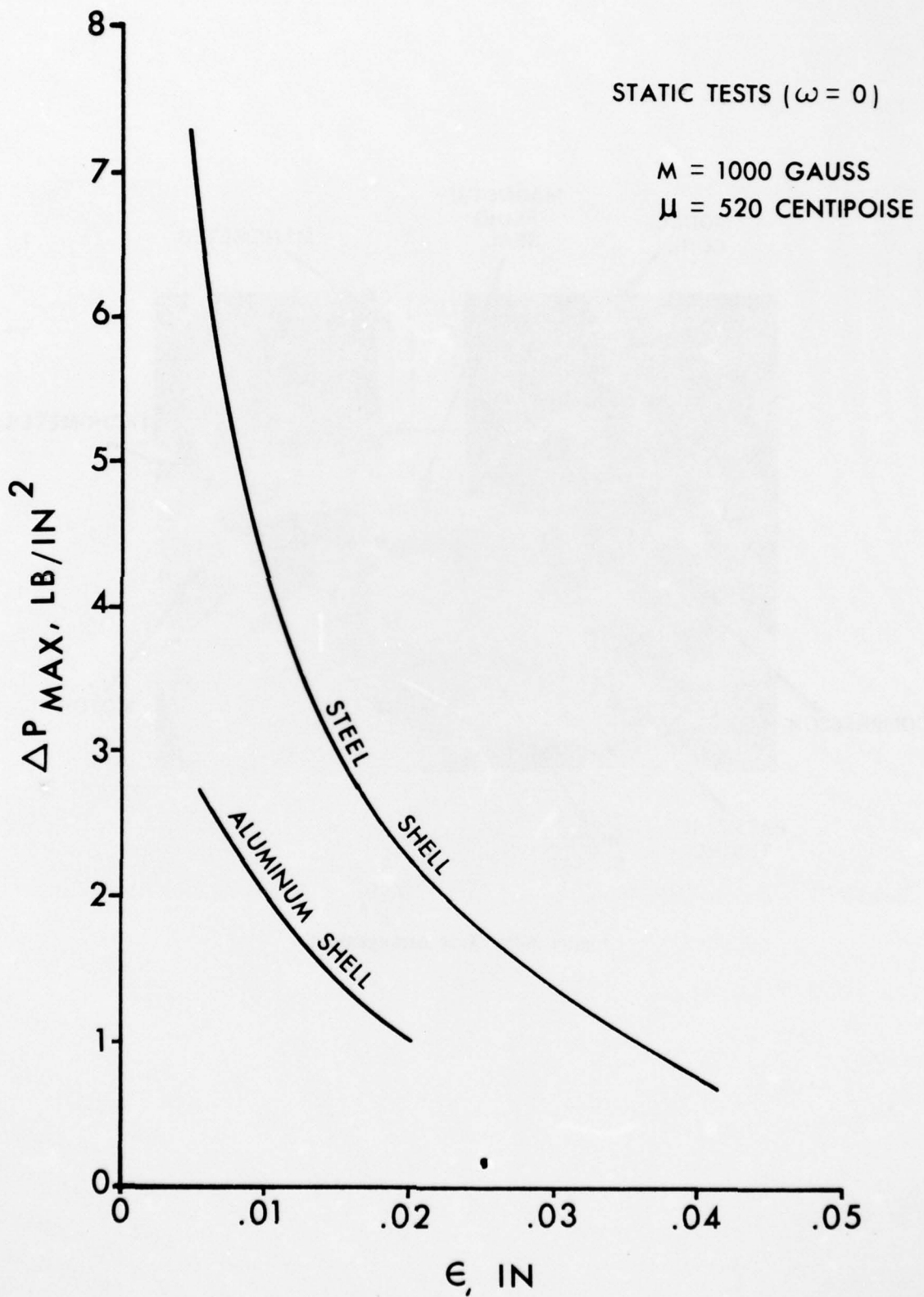

Figure A-10. Effect of Gap Dimension on Static Seal Performance

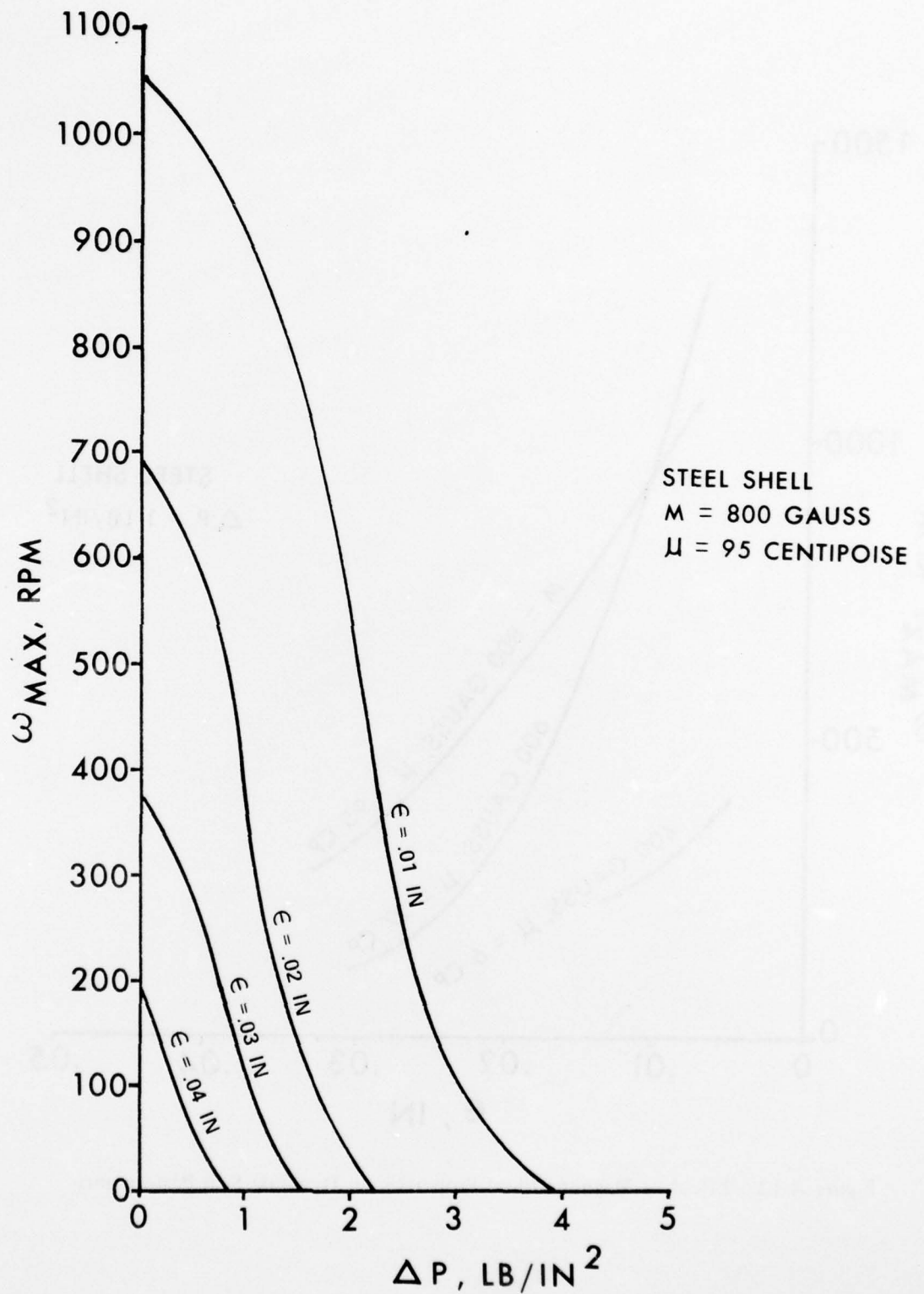

Figure A-11. Effect of Gap Dimension on Dynamic Seal Performance

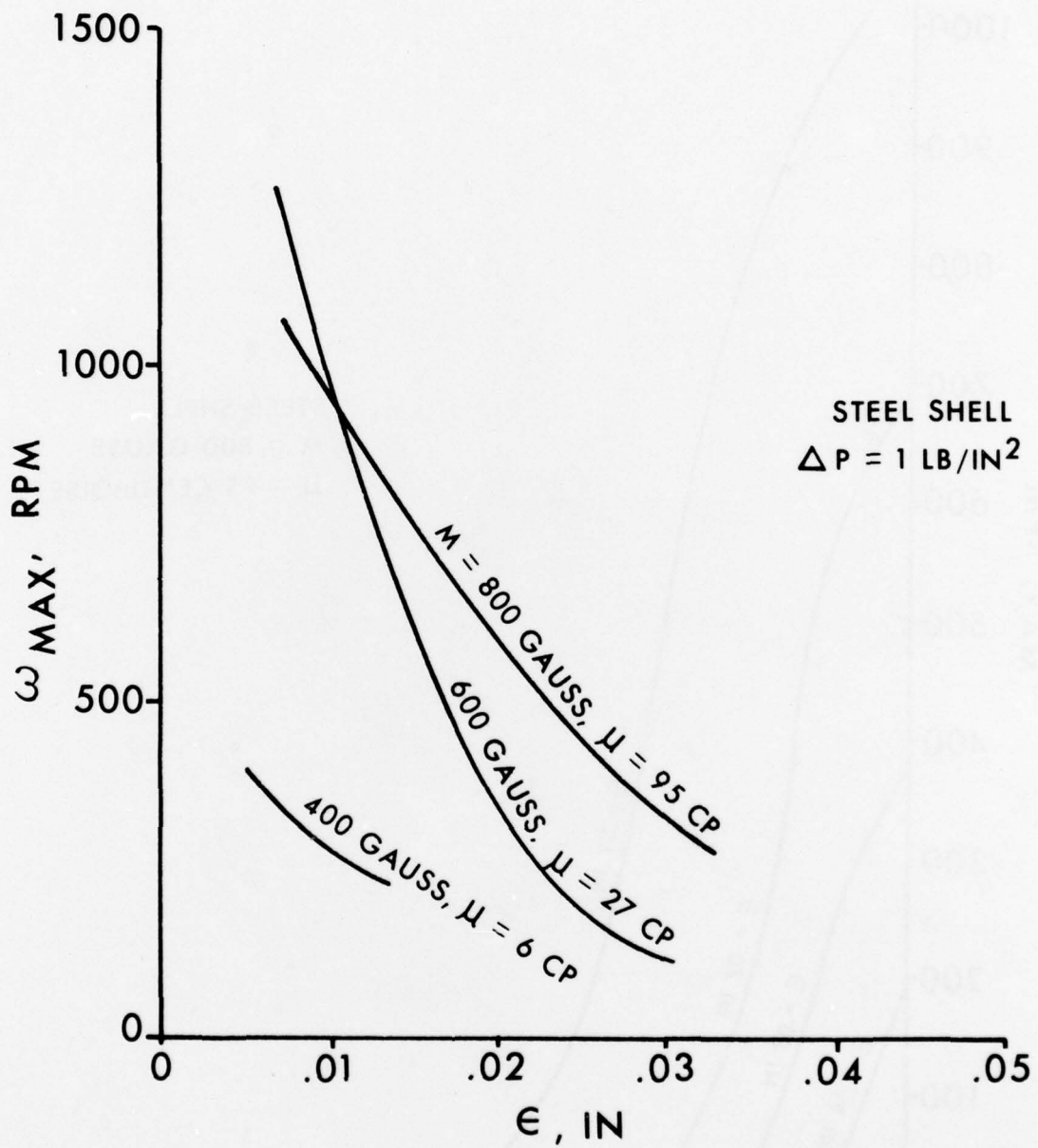

Figure A-12. Effect of Magnetic-Fluid Properties on Dynamic Seal Performance

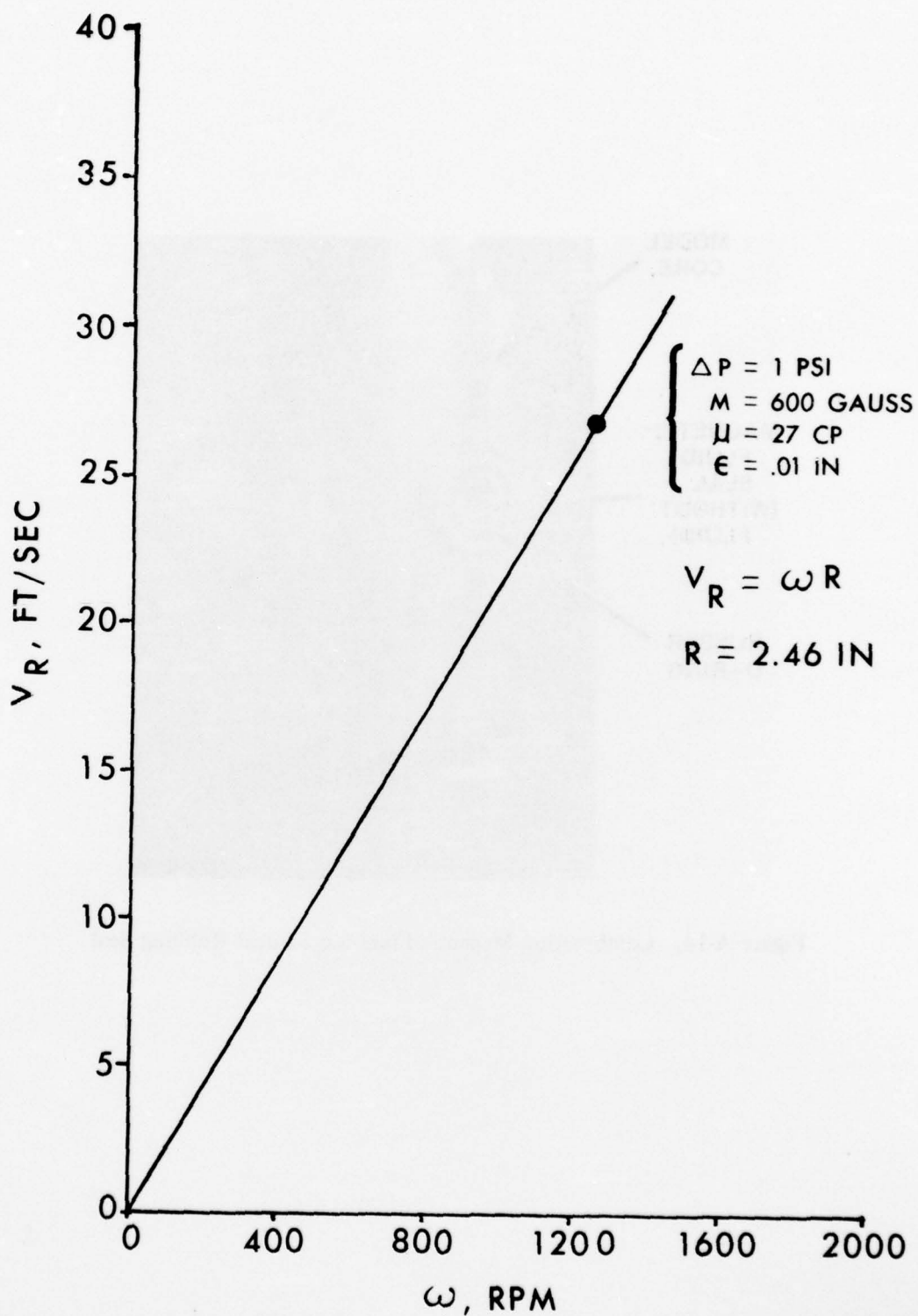

Figure A-13. General Magnetic-Fluid Sliding-Seal Performance

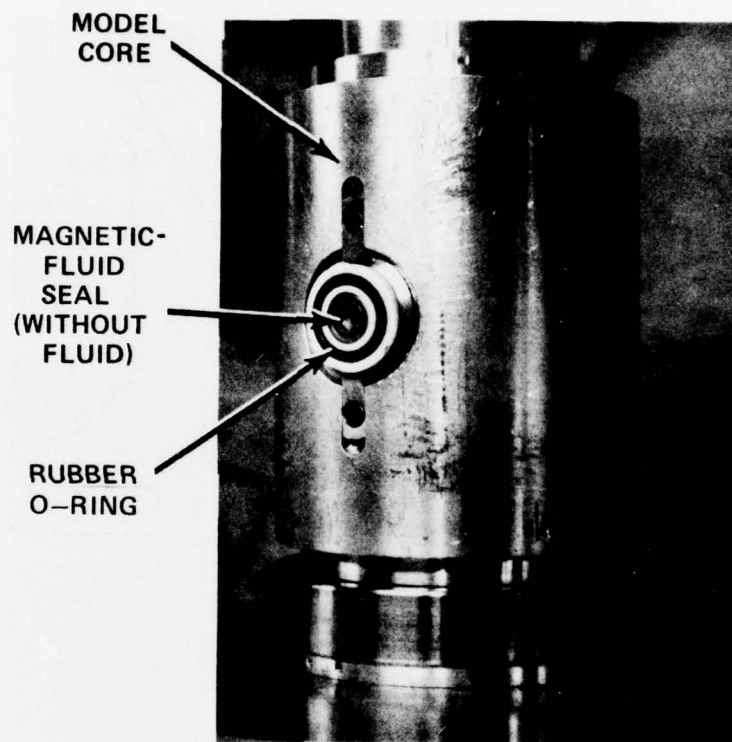

Figure A-14. Combination Magnetic-Fluid/Mechanical Rubbing Seal

DISTRIBUTION LIST FOR ARCSL-TR-77018

Names	Copies	Names	Copies
CHEMICAL SYSTEMS LABORATORY		Commander	
OFFICE OF THE DIRECTOR		US Army Missile Command	
Attn: DRDAR-CLD	1	Attn: DRSMI-R	1
Attn: DRDAR-CLP	1	Attn: DRSMI-RDK/Mr. R. Deep	1
SAFETY OFFICE		Redstone Arsenal, AL 35809	
Attn: DRDAR-CLF	1	US ARMY ARMAMENT RESEARCH AND DEVELOPMENT COMMAND	
AUTHOR'S COPIES, Weapon Systems Concepts Team, Attn: DRDAR-ACW	6	Commander	
DEVELOPMENTAL SUPPORT DIVISION		US Army Armament Research and Development Command	
Attn: DRDAR-CLJ-I	4	Large Caliber Weapons Systems Laboratory	
MUNITIONS DIVISION		Attn: DRDAR-AC/Dr. J. Davis	1
Attn: DRDAR-CLN	1	Attn: DRCPM-CAWS/COL R. E. Philipp	1
RESEARCH DIVISION		Attn: DRDAR-TDR/DR. R. J. Eichelberger	1
Attn: DRDAR-CLB-C	1	Attn: DRDAR-LCA/Mr. R. Kline	1
DEPARTMENT OF DEFENSE		Attn: DRDAR-LCA/Mr. S. Kahn	1
Administrator		Attn: DRDAR-LCS/Mr. S. Wasserman	1
Defense Documentation Center		Attn: DRDAR-LCW/Mr. H. Garver	1
Attn: Accessions Division		Technical Support Directorate	
Cameron Station		Attn: DRDAR-TSE-EE/Mr. C. DeFranco	1
Alexandria, VA 22314		Dover, NJ 07801	
Director		Director, Ballistic Research Laboratory	
Defense Intelligence Agency		USA ARRADCOM	
Attn: DB-4G1	1	Attn: DRDAR-BLL/Dr. C. Murphy, Jr.	1
Washington, DC 20301		Attn: DRDAR-BLL/Mr. A. Platou	1
DEPARTMENT OF THE ARMY		Attn: DRDAR-BLL/Mr. R. Krieger	1
HQDA (DAMO-SSC)	1	Attn: DRDAR-BLL/Dr. A. Mark	1
WASH DC 20310		Attn: DRDAR-BLL/Mr. R. McCoy	1
Chief, Office of Research, Development & Acquisition		Attn: DRDAR-BLL/Mr. J. Whiteside	1
Attn: DAMA-CSM-CM	1	Attn: DRDAR-BLL/Mr. L. Kayser	1
Attn: DAMA-ARZ-D	1	Building 328	
Washington, DC 20310		Aberdeen Proving Ground, MD 21005	
US ARMY MATERIEL DEVELOPMENT AND READINESS COMMAND		CDR, APG	
Commander		USA ARRADCOM	
US Army Materiel Development and Readiness Command		Attn: DRDAR-GC	1
Attn: DRCDE-DW	1	Attn: DRDAR-SEI-C	1
Attn: DRCDE-R	1	Attn: DRDAR-ACW	1
Attn: DRCSEF-S	1	Aberdeen Proving Ground, MD 21010	
5001 Eisenhower Ave		US ARMY ARMAMENT MATERIEL READINESS COMMAND	
Alexandria, VA 22333		CDR, APG	
Commander		USA ARRCOM	
US Army Foreign Science & Technology Center		Attn: SARTE	1
Attn: DRXST-IS1	2	Aberdeen Proving Ground, MD 21010	
220 Seventh St., NE		US ARMY TRAINING & DOCTRINE COMMAND	
Charlottesville, VA 22901		Commandant	
		US Army Missile & Munitions Center & School	
		Attn: ATSK-CD-MD	1
		Attn: ATSK-DT-MU-EOD	1
		Redstone Arsenal, AL 35809	

DISTRIBUTION LIST FOR ARCSL-TR-77018 (Contd)

Names	Copies	Names	Copies
Commander US Army Ordnance & Chemical Center & School Attn: ATSL-CD-MS Aberdeen Proving Ground, MD 21005	1	DEPARTMENT OF THE AIR FORCE Commander Aeronautical Systems Division Attn: ASD/ASAMCC Wright-Patterson AFB, OH 45433	1
US ARMY TEST & EVALUATION COMMAND		Commander AFATL Attn: DLRA/Technical Library Attn: DLJC/MAJ J. Key Eglin AFB, FL 32542	1 1
Record Copy CDR, APG Attn: STEAP-AD-R/RHA APG-Edgewood Area, Bldg E5179	1	Commander AFFDL Wright-Patterson AFB, OH 45433	1
CDR, APG Attn: STEAP-TL APG-Aberdeen Area	1	DEPARTMENT OF THE NAVY	
DEPARTMENT OF THE NAVY		OUTSIDE AGENCIES	
Commander Naval Surface Weapons Center Attn: Code 312(R. Regan/S. Hastings) Attn: Code 730/Tech Lib & Info Svcs Br White Oak Laboratory Silver Spring, MD 20910	1 2 1	Massachusetts Institute of Technology Attn: Prof C. Haldeman 77 Massachusetts Avenue Cambridge, MA 02139	1
Commander Naval Surface Weapons Center Dahlgren Laboratory Attn: Code KBB/Mr. P.Daniels Attn: Code DA40/Dr. W.R.Chadwick Dahlgren, VA 22448	1 1 1	University of Notre Dame Department of Aerospace/Mechanical Engineering (Box 537) Attn: Dr. T. J. Mueller Notre Dame, IN 46556	1
Commander Naval Weapons Center Attn: Dr. W.Haseltine/Code 6003 Attn: Technical Library/Code 233 China Lake, CA 93555	1 1	ADDED ADDRESSEES	
Commander US Naval Ordnance Systems Command Attn: ORD-0631 Attn: ORD-035 Attn: ORD-5524 Washington, DC 20360	1 1 1	Commander US Army Research Office Attn: DRXRD-EG-1492/Mr. R. E. Singleton P. O Box 12211 Research Triangle Park, NC 27709	1
Director US Office of Naval Research Attn: Mr. S. Curley 495 Summer Street Boston, MA 02210	1	Director US Army BMD Advanced Technology Center P. O. Box 1550 Huntsville, AL 35809	1
Director US Naval Research Laboratory Attn: Technical Infl. Division Attn: Code 7720/Dr. A. Kolb/Dr. E.McCLean Washington, DC 20390	1 2	Environmental Sciences Services Administration Attn: Code 82.70/J. W. Wright Boulder, CO 80301	1
		Director National Bureau of Standards Attn: Technical Library US Department of Commerce Washington, DC 20234	1
		Director National Aeronautic and Space Administration Attn: Technical Library Goddard Space Flight Center Greenbelt, MD 20771	1

DISTRIBUTION LIST FOR ARCSL-TR-77018 (Contd)

Names	Copies	Names	Copies
Director National Aeronautics and Space Administration Attn: MS 185/Technical Library Langley Station Hampton, VA 23365	1	Sandia Laboratories Attn: Areodynamics Department Attn: Org 5620/Mr. R. Maydew Attn: Div 5625/Mr. W. Curry/Mr. W. Caudle Attn: Div 5625/Mr. H. Vaughn/Mr. A. Wilson Albuquerque, NM 87115	1 1 2 2
Director National Aeronautics and Space Administration Scientific and Technical Information Facility Attn: SAK/DL P. O. Box 33 College Park, MD 20740	1	University of Maryland Department of Aeronautical Engineering Attn: Professor W. L. Melnik College Park, MD 20740	1
ARO, Inc Attn: Technical Library Arnold AFB, TN 37389	1	University of Maryland Department of Mechanical Engineering Attn: R C. Marks Attn: Dr. Sallet College Park, MD 20740	1 1
California Institute of Technology Aeronautics Department Attn: Professor H. Liepmann Pasadena, CA 91102	1	University of Virginia Department of Aeronautical Engineering Attn: Professor I. Jacobson Charlottesville, VA 22901	1
California Institute of Technology Guggenheim Aeronautical Laboratory Attn: Technical Library Pasadena, CA 91103	1	Iowa State University Department of Aeronautical Engineering Attn: Professor J. D. Iverson Ames, Iowa 50010	1
Director Guggenheim Aerospace Laboratory New York University New York Heights New York, NY 10053	1	Dr. Ronald Moskowitz Ferrofluidics Corporation 144 Middlesex Turnpike Burlington, MA 01803	2
Calspan Corporation Attn: Library P. O. Box 235 Buffalo, NY 14421	1		
Director Applied Physics Laboratory Johns Hopkins University Laurel, MD 20810	1		
Director Department of Aeronautics Johns Hopkins University 34th & Charles Sts Baltimore, MD 21218	1		
Massachusetts Institute of Technology Department of Aeronautics and Astronautics Attn: Technical Library 77 Massachusetts Avenue Cambridge, MA 02139	1		
Ohio State University Department of Aeronautical and Astronautical Engineering Attn: Technical Library Columbus, OH 43210	1		