

AD-A040 373

OREGON GRADUATE CENTER BEAVERTON
MECHANISM OF ENHANCED TOUGHNESS IN MARTENSITIC ALLOYS. (U)
APR 77 W E WOOD

F/6 11/6

N00019-76-C-0149

NL

UNCLASSIFIED

| OF |
AD
A040373

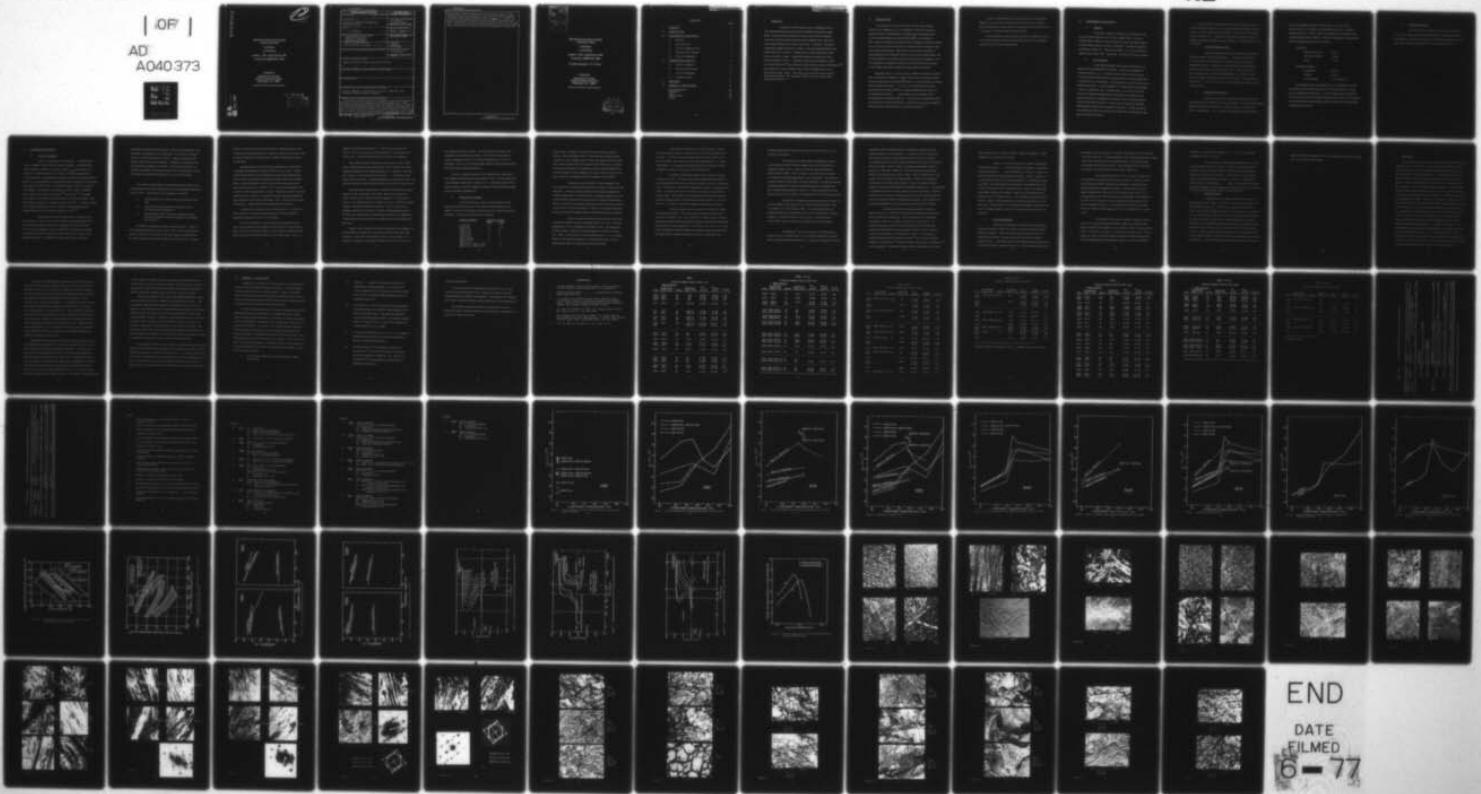

END
DATE
FILMED
6-77

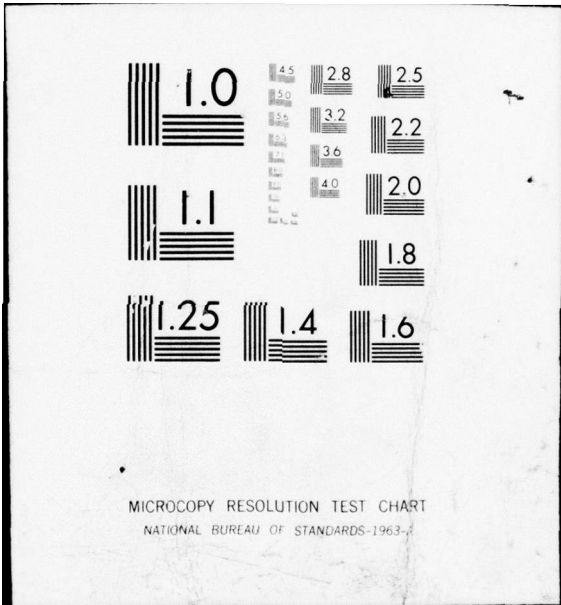

AD A 0 4 0 3 7 3

12
NW

Mechanism of Enhanced Toughness
In Martensitic Alloys

Final Report
For the Period

October 1, 1975 - September 30, 1976

Contract No. N00019-76-C-0149

Prepared for

Department of the Navy
Naval Air Systems Command
Washington, D.C. 20361

Approved for public release, distribution unlimited.

AD No. _____
DDC FILE COPY

OK DDC
RECEIVED
JUN 9 1977
REGISTRY
D

Unclassified

SECURITY CLASSIFICATION OF THIS PAGE (When Data Entered)

| REPORT DOCUMENTATION PAGE | | READ INSTRUCTIONS BEFORE COMPLETING FORM |
|--------------------------------------------------------------------------------------------------------------------------------------------------------------------------------------------------------------------------------------------------------------------------------------------------------------------------------------------------------------------------------------------------------------------------------------------------------------------------------------------------------------------------------------------------------------------------|-----------------------|---------------------------------------------------------------------------------|
| 1. REPORT NUMBER | 2. GOVT ACCESSION NO. | 3. RECIPIENT'S CATALOG NUMBER |
| 4. TITLE (and Subtitle) Mechanism of Enhanced Toughness in Martensitic Alloys | | 5. TYPE OF REPORT & PERIOD COVERED Final Report ✓ 10-1-75 to 9-30-76 |
| 7. AUTHOR(s) W. E. Wood | | 6. PERFORMING ORG. REPORT NUMBER |
| 9. PERFORMING ORGANIZATION NAME AND ADDRESS Oregon Graduate Center ✓ 19600 N.W. Walker Rd. Beaverton, OR 97005 | | 8. CONTRACT OR GRANT NUMBER(s) N00019-76-C0149 <i>new</i> |
| 11. CONTROLLING OFFICE NAME AND ADDRESS Naval Air Systems Command | | 10. PROGRAM ELEMENT, PROJECT, TASK AREA & WORK UNIT NUMBERS 20 Apr 77 |
| 14. MONITORING AGENCY NAME & ADDRESS (if different from Controlling Office) | | 12. REPORT DATE 4-20-77 |
| | | 13. NUMBER OF PAGES 75 |
| | | 15. SECURITY CLASS. (of this report) Unclassified |
| | | 15a. DECLASSIFICATION/DOWNGRADING SCHEDULE |
| 16. DISTRIBUTION STATEMENT (of this Report) Approved for public release, distribution unlimited <i>Final rept. 1 Oct 75 - 30 Sep 76</i> | | |
| 17. DISTRIBUTION STATEMENT (of the abstract entered in Block 20, if different from Report) | | |
| 18. SUPPLEMENTARY NOTES | | |
| 19. KEY WORDS (Continue on reverse side if necessary and identify by block number) Fracture toughness, microstructure, 4340 steel, 300M steel, heat treatment, retained austenite, twinning | | |
| 20. ABSTRACT (Continue on reverse side if necessary and identify by block number) The objective of this program was to establish the role of heat treatment parameters on the fracture toughness of ultrahigh strength alloys. Microstructural examination and plane strain fracture toughness tests were conducted on alloys 4340 and silicon modified 4340. Heat treatments included both direct as well as step quench schedules. Solutioning temperatures ranged from 870°C to 1200°C, and step quenching temperatures ranged from 300°C to 1100°C. (see reverse) | | |

DD FORM 1473 1 JAN 73

EDITION OF 1 NOV 65 IS OBSOLETE S/N 0102-LF 014 6601

Unclassified

SECURITY CLASSIFICATION OF THIS PAGE (When Data Entered)

390 077

mt

Unclassified

SECURITY CLASSIFICATION OF THIS PAGE(When Data Entered)

Holding times at these temperatures varied from 10 seconds to 2 hours. Tempering temperatures ranged from the as quenched condition to 350°C. Valid plane strain fracture toughness results of over 90,000 psi-in^{1/2} were achieved for alloy 4340 and values of 85,000 psi-in^{1/2} were achieved for silicon modified 4340 at ultimate strength levels of over 300,000 psi for both alloys. This report covers the first year's results of the two year program. The second year will be covered in a final report planned for October 1977.

Unclassified

SECURITY CLASSIFICATION OF THIS PAGE(When Data Entered)

| | |
|---------------------------------|---------------------------------------------------|
| ACCESSION for | |
| NTIS | White Section <input checked="" type="checkbox"/> |
| GDS | Buff Section <input type="checkbox"/> |
| UNANNOUNCED | <input type="checkbox"/> |
| JUSTIFICATION | |
| BY | |
| DISTRIBUTION/AVAILABILITY CODES | |
| DISC. | AVAIL. and/or SPECIAL |
| A | |

**Mechanism of Enhanced Toughness
In Martensitic Alloys**

Final Report

For the Period

October 1, 1975 - September 30, 1976

Contract No. N00019-76-C-0149

Principal Investigator: W. E. Wood

Prepared for

**Department of the Navy
Naval Air Systems Command
Washington, D.C. 20361**

Approved for public release, distribution unlimited.

**D D C
RECEIVED
JUN 9 1977
RECEIVED
D**

CONTENTS

| | PAGE |
|--------------------------------------|------|
| I. <u>ABSTRACT</u> | 1 |
| II. <u>INTRODUCTION</u> | 2 |
| III. <u>EXPERIMENTAL PROCEDURE</u> | 4 |
| A. Material | 4 |
| B. Heat Treatment | 4 |
| C. Fracture Toughness Tests | 5 |
| D. Microstructural Analysis | 5 |
| E. Fracture Morphology | 7 |
| IV. <u>EXPERIMENTAL RESULTS</u> | 8 |
| A. Fracture Toughness | 8 |
| B. Microstructure Results | 12 |
| C. Fracture Morphology | 17 |
| D. Hardness Testing | 19 |
| V. <u>DISCUSSION</u> | 21 |
| VI. <u>SUMMARY & CONCLUSIONS</u> | 24 |
| Acknowledgements | 26 |
| References | 27 |
| Tables | 28 |
| Figure Captions | 36 |
| Figures | 40 |

I. ABSTRACT

The objective of this program was to establish the role of heat treatment parameters on the fracture toughness of ultrahigh strength alloys. Microstructural examination and plane strain fracture toughness tests were conducted on alloys 4340 and silicon modified 4340. Heat treatments included both direct as well as step quench schedules. Solutioning temperatures ranged from 870°C to 1200°C, and step quenching temperatures ranged from 300°C to 1100°C. Holding times at these temperatures varied from 10 seconds to 2 hours. Tempering temperatures ranged from the as quenched condition to 350°C. Valid plane strain fracture toughness results of over 90,000 psi-in^{1/2} were achieved for alloy 4340 and values of 85,000 psi-in^{1/2} were achieved for silicon modified 4340 at ultimate strength levels of over 300,000 psi for both alloys. This report covers the first year's results of the two year program. The second year will be covered in a final report planned for October 1977.

II. INTRODUCTION

The emergence of fracture mechanics and the concept of plane strain fracture toughness, K_{IC} , as a quantitative means of a material's tendency to fail in a brittle manner is playing an increasingly important role in the selection and use of high strength alloys⁽¹⁾. Such steels are often chosen according to this relative fracture toughness at different strength levels, and the use of these materials is limited by their low fracture toughness at high strength levels. Hence there is a great need to develop an understanding of the mechanisms involved in the fracture of these alloys, and an understanding of the variables which control the fracture toughness. It is the recognition and utilization of these factors which will provide the basis for the design of new high strength alloys with superior properties.

Maraging steels, as a class of alloys, exhibit one of the best combinations of strength and toughness available, better than conventionally treated low alloy steels such as 4140 and 4340⁽²⁾. However, cost limits their use except where absolutely necessary. Results have indicated that the long associated poor toughness of these very high strength low alloy steels can be significantly improved, approaching the values obtained for the maraging steels, without the high cost. This has been accomplished by altering only the heat treatment procedures. Furthermore the fracture toughness levels have been achieved without a reduction in strength.⁽³⁻⁶⁾

In order to understand the role of microstructure on the fracture toughness it is necessary to characterize the microstructure carefully. This investigation has utilized optical, transmission, and scanning electron microscopy in conjunction with mechanical testing.

The main objective of this program has been to establish the critical role of heat treatment parameters on the plane strain fracture toughness of alloys 4340 and silicon modified 4340.

III. EXPERIMENTAL PROCEDURE

A. Material

The program examined two alloys, aircraft quality 4340, mil specification AMS 6359, and a silicon modified 4340. The silicon modified 4340 or 300M, as it will be referred to in this report, was obtained from the Boeing Company in Seattle, Washington. The Boeing Company's specification is BMS 7-26. This alloy contained 1.6 wt. percent silicon in addition to the normal 4340 composition. The alloy was vacuum remelted.

B. Heat Treatment

A controlled atmosphere tube furnace was utilized for all high temperature austenitization treatments. This furnace maintained a temperature within $\pm 5^{\circ}\text{C}$. Test specimens were either quenched directly from the solution temperature into an agitated oil bath or step quenched into a salt bath prior to oil quenching. All tempering was carried out for an hour. Standard step quench involved holding for 30 minutes before oil quenching. In order to evaluate the effect of holding time, one series of tests was carried out using several holding times varying from 10 seconds to 2 hrs. These specimens were stepped into salt baths to insure rapid thermal equilibrium for the short hold times. All tests were carried out on standard ASTM compact tension fracture toughness specimens. Sections for optical and transmission electron microscopy were taken from mid-thickness areas adjacent to the fracture path.

For the isothermal transformation to bainite and retained austenite, 4340 and 300M were again used. By varying the isothermal holding time the amount of retained austenite was controlled. To insure a fine lower bainite structure the alloy was transformed in salt baths just above the M_s temperature. Retained austenite has been qualitatively estimated from electron microscopy.

C. Fracture Toughness Tests

All fracture toughness tests were carried out using ASTM specified compact tension test specimens. Testing was carried out at room temperature. Specimens were 5/8" thick and were tested in the longitudinal direction. All specimens were machined to final dimensions prior to heat treating except for the starter slot. This was added after heat treating by using a .008" thick grinding wheel. A 22,000 lb Instron Lawrence dynamic test system was used for all testing, including fatigue precracking. Stress intensities were calculated according to ASTM standards E399.

D. Microstructural Analysis

Sections for optical and transmission electron microscopy were taken from the midsection of the K_{Ic} specimens. For optical metallography polished specimens were etched in a combination picral and nital etch. Thin foil preparation was carried out using both the window technique

and the jet polishing technique, (Fischione unit). Two electrolytes, glacial acetic acid + perchloric acid and glacial acetic acid + chromium trioxide, were used. The best results were obtained from the latter in conjunction with the window technique. The exact composition of the electrolyte and the polishing conditions are given below:

Electrolyte:

| | |
|---------------------|--------|
| Glacial Acetic Acid | 135 ml |
| Chromium Trioxide | 25 gms |
| Water | 7 ml |

Polishing Conditions:

| | |
|-----------------|-----------------------------|
| Temperature | 10-15° C |
| Voltage | 25 volts |
| Current density | 0.1-0.2 Amp/cm ² |

The starting material was obtained in 10-15 mil thickness sections by cutting heat treated specimens with a 1/32" abrasive wheel. Sections were cut while flooded with water. A very low cutting rate was employed. These 10-15 mil sections were then carefully ground to about 5 mils thickness. From this thickness final polishing by either the window or the jet polishing technique was carried out.

E. Fracture Morphology

Secondary electron scanning microscopy was carried out at 25 KV. For each specimen the region adjacent to the fatigue precrack was examined, since this is the region of crack initiation during the K_{IC} test. This region typically extends about .030" from the fatigue crack.

IV. EXPERIMENTAL RESULTS

A. Fracture Toughness

Tables 1-4 and Figures 1-11 summarize the plane strain fracture toughness results obtained during this program. All the data were valid except those marked by an asterisk, where P_{\max}/P_q exceeded 1.10. Figures 1-9 graphically illustrate the effects of various heat treatments. For both alloys the conventional heat treatment consisted of solutioning at 870°C (1600°F) for one hour followed by oil quenching. The effect of increasing the austenitizing temperature from 870 to 1200°C is apparent in Figure 1 for the as quenched test condition. Increasing the temperature from 870 to 1100°C resulted in only a small increase from about 35 ksi-in^{1/2} to 43 ksi-in^{1/2}. Not shown in this figure, but included in the tables is data for a 1150°C treatment. This heat treatment resulted in a toughness of about 52 ksi-in^{1/2}. Further increases in the solution temperature to 1200°C and direct quenching produced the highest toughness in the as quenched condition, 66 ksi-in^{1/2}.

Aside from the increased toughness due to raising the solution temperature, Figure 1 also reveals the effect of step quenching to 870°C for successively longer holding times. Stepping to 870°C for 30 seconds did not reduce the toughness, but it is doubtful that 30 seconds in a salt bath was sufficient to reduce the specimen temperature to 870°C. Hence, little change was expected. Continuing work during the 2nd year will include

instrumented cooling and quenching data to confirm actual equilibrium time-temperature relationships for step quenching. Five minutes is sufficient, however, to reduce the specimen to 870°C. Figure 1 demonstrates the negative effect on the fracture toughness. Holding for 30 minutes and one hour reduced the toughness even further. Not shown in the figures, but included in the tables are the results of short time 15 minute holds at 1200°C. The results demonstrated that holding for 1 hour was not necessary.

The trends present in Figure 1 demonstrate the major effects of heat treatment which were true for both alloys and for all tempering temperatures up to 175-200°C. These effects can be summarized as follows:

- (1) Direct quenching from 1200°C produced the highest toughness.
- (2) Direct quenching from lower temperatures produced successively lower toughnesses.
- (3) Step quenching to 870°C reduces the toughness with the extent of the toughness reduction dependent on the holding time at 870°C.

The effects of tempering on 4340 are shown in Figure 2. There are several important features on these curves. First, for low tempering temperatures, below 175°C, the 1200°C clearly has superior toughness while the 1100°C treatment provides little benefit over that of the 870°C treatment.

Second, for these tests, the conventional 870°C treatment produced a continuously increasing toughness as the tempering temperature increases, while the higher temperature treatments show a definite embrittlement reaction at about 200°C.

Step quenching to just above the M_s temperature for either partial or complete transformation to bainite resulted in mixed results. Figure 3 indicates that tempering after transformation improved the toughness and that this trend is also shown by specimens partially transformed to bainite. Hence, even for the bainitic structure a large grain size was necessary. Also shown in Figure 3 are a 1200°C → 315°C for 10 second step quench and a 1200°C → 1100°C step quench for 1 minute. Both these resulted in very high toughness levels. However, it is doubtful that either specimen reached the step temperature before final oil quenching. Hence, these structures should be martensitic. Again instrumented quenching data is necessary.

A comparison of Figures 2 and 3 is shown in Figure 4. Clearly the direct quench or very rapid step quench produced the best toughness if tempering temperatures below 175°C are utilized.

The fracture toughness results obtained by step quenching to just above the M_s temperature and holding for various times are summarized in tables 3 and 4 for both 4340 and 300M. For alloy 4340 the results show that there were several combinations which yielded plane strain fracture

toughness data above 90,000 psi-in^{1/2}. Table 3 also reveals that the 1200°C → 1100°C can result in very high toughness, if the holding time at 1100 is short. Prolonged holding produced a sharp drop in toughness.

Alloy 300M behaved in basically the same manner as 4340. Again Figure 5 indicates that the direct quench from 1200°C produced the highest toughness independent of the tempering temperature employed. One difference, however, is the lack of the severe temper embrittlement reaction present in alloy 4340. For alloy 300M the direct quench from 1200°C was superior regardless of the tempering temperatures used in this study to date.

Step quenching to either partial or complete transformation to bainite produced results comparable to alloy 4340. Again, prior treatment at 1200°C was necessary to achieve maximum toughness. A comparison of Figures 5 and 6 shows that the direct quench from 1200°C produced the highest toughness, although the difference was small. However, there was not sufficient material to test the effect of higher austenitizing temperatures. The effect of a small amount of transformation to bainite is not significant for alloy 300M, whereas it produced a significant drop in the toughness for alloy 4340.

Figures 8 and 9 compare the effects of tempering on the toughness of 4340 and 300M for both the 870°C and the direct quench from 1200°C heat treatment. For the 870°C treatment the curves are very similar. The difference in toughness at tempering temperatures above 150°C was due to

the tempering resistance of 300M. The added silicon content has a well known effect on the tempering reaction. For the 1200°C treatment the maximum toughness occurred at a tempering temperature of 175°C for both alloys. However, the strength of alloy 300M is about 20,000 psi greater than 4340 at this tempering temperature.

In order to compare this data to other published data, these maximum toughness levels have been superimposed on data for these alloys and other ultrahigh strength steels, Figures 10-11. Clearly the modified treatments resulted in a fracture toughness equivalent to the 18% Nickel maraging steels at equivalent strength levels.

B. Microstructure Results

The microstructure of each alloy was examined by both optical and electron microscopy. Both replica and foil techniques were utilized. Grain size calculations were carried out for various austenitizing treatments. The results are summarized as follows:

| <u>Solution Treatment</u> | <u>Grain Size, ASTM</u> | |
|-----------------------------|-------------------------|-------------|
| | <u>4340</u> | <u>300M</u> |
| as received | 9 | 6.5 |
| 870°C/1 hr. | 9 | 6.5 |
| 1000°C/1 hr | 9 | 4 |
| 1100°C/1 hr. | 5.5 | 2 |
| 1100°C/2 hr. | - | 2 |
| 1150°C/1 hr. | 3 | 2 |
| 1200°C/15 min. | 1 | - |
| 1200°C/30 min. | 1 | - |
| 1200°C/1 hr. | 1 | 2 |
| 1200°C/1 hr - 1100°C/15 min | - | 2 |
| 1200°C/1 hr - 1100°C/1 hr | - | 2 |

Clearly 4340, a rolled plate material had a finer grain size initially. However, after solutioning at 1200°C, both alloys have ASTM grain size of about 1-2. Step quenching does not result in a further increase in grain size. Since the grain size is very large after the 1100°C/1 hr. treatment but the fracture toughness is unchanged, and since step quenching did not result in as high a fracture toughness as the direct quench, then grain size per se can not be controlling the fracture toughness of these alloys.

Obviously, the heat treatment, fracture toughness, and microstructure are all interrelated and thus it is difficult to discuss any one separately. The heat treatment schedules and the alloys themselves are complex enough in that it is difficult to give a simplified explanation for any microstructural interpretation let alone fracture toughness interpretation. However, several microstructural observations can be made which all effect the final result, the fracture toughness. Figures 18-28 contain optical and electron micrographs including replicas and thin foil electron micrographs.

Figure 18 reveals the banded structure of alloy 4340 in the as-quenched condition and after solutioning at 870°C for 1 hour. While the banding which is due to segregation is no longer visible, the segregation probably remains. Electron microprobe analysis is required to confirm this. Figure 21 which shows as-received 300M does not reveal banding. However, alloy 300M was obtained as a forging whereas alloy 4340 was supplied under AMS 6359 specifications for plate material.

Large dark etching plates are visible in Figure 18. These are most probably martensitic plates which have been autotempered during the quench. In some of these dark etching plates a parallel series of sub-units are visible, when viewed under very high magnifications, i.e. 2000X. Unfortunately, it is impossible to uniquely identify these optically, and the probability of finding an isolated area with thin foil is low.

Examples of 4340 given a bainitic heat treatment are shown in Figures 19 and 20. The effect of an initially banded segregated structure on the subsequently heat treated structure is evident in Figure 19. Referring to the TTT curves it is seen that this sample should contain a small amount of bainite. The segregated nature of the bainite in a matrix of martensite is clearly visible. Upon cooling to room temperature the remaining austenite underwent transformation to martensite and retained austenite. A one hour hold at 315°C resulted in essentially complete transformation to bainite.

Figure 20 reveals the microstructure of 4340 after an initial austenitization of 1200°C. The large grain size makes the bainitic structure easier to identify. The 3 min. hold at 335°C results in about 25% transformation to bainite with the remainder essentially transforming to martensite upon quenching to room temperature. The carbide precipitation can be easily distinguished in higher magnification replicas which also clearly show the duplex bainitic-tempered martensitic structure, as opposed to the

essentially fully bainitic structure present in specimens held for 1 hr. in salt prior to quenching.

Microstructures of alloy 300M corresponding to various heat treatments for which fracture toughness data was also obtained are included in Figures 21-23. There are several noteworthy differences between 4340 and 300M. First, in Figure 21, very fine residual carbides are visible as small black spots about 0.5 μ m in diameter. There were no residual carbides in alloy 4340 for this heat treatment. The high austenitizing treatment did produce a network of dark etching plates surrounding most prior austenite grain boundaries, Figure 21. These are present in the fine grain case, but not very evident at low magnification due to the fine grain size.

Isothermally transformed structures are shown in Figure 22. For alloy 300M, a 3 min. hold at 315°C or 350°C should only produce about 2-5% bainite for a 1-1/2% silicon content. The remaining austenite has evidently transformed to martensite for the case of an initial 870°C solution treatment. Retained austenite is found, however, within the bainitic ferrite laths as shown in thin foil transmission electron micrographs.

By holding for 1 hour at 310°C about 75% transformation to bainite occurs according to the TTT curve after an initial 900°C solution. This is in good agreement with Figures 23. Figure 23a has large white area

representing either retained austenite or untempered martensite formed during the quench to room temperature. Tempering at 200°C transformed these white regions into a dark etching structure, Figure 23b. Similar micrographs for a prior 1200°C solution treatment are included in Figures 23c and 23d for 300M. However, there is one important difference evident in Figure 23d. Again after holding for 1 hour the structure was essentially bainitic with a small amount of white islands. However tempering for 1 hour at 200°C did not eliminate these white islands. If these were untempered martensite they would have been tempered. Hence, the stability of these regions is different and depends on the solutioning temperature. It is impossible to establish the structure of these regions by optical microscopy. Transmission electron microscopy is underway as part of the second year program in order to determine the effect of solutioning temperature, silicon content and tempering temperature on the structures present under these conditions.

Transmission electron microscopy results are shown in Figures 24 and 25 for alloy 4340 for both large and fine grain size for both direct and step quench situations. Thin foil analysis for two step quench treatments to 1100°C are included, Figures 24 c-f and Figure 25. Of possible significance is the fact that the sample held for 30 minutes was extensively twinned while the specimen held at 1100°C for only 10 minutes contained very few twins. Referring back to Table 3, it is clear that a significant drop in fracture toughness occurred. The 10 minute hold had a toughness of 93,460 psi-in^{1/2} while the 30 minute hold had only 68,000 psi-in^{1/2} fracture toughness. Also note the large variation in plate sizes for this and

other sections as well. Finally, extensive carbide precipitation is visible throughout all the tempered structures.

Figures 26-28 reveal the structure of 300M. Bright field, dark field and corresponding diffraction patterns are shown. The retained austenite distribution can be seen in the figures. In Figure 27 a and b, the dark films between the ferrite laths are austenite. However, Figure 27c reveals that the structure is not entirely bainitic, i.e. martensitic regions are visible. This shows that some austenite was not stabilized after 1 hr. at 350°C given a prior 870°C solution treatment. Figure 28 is also 300M isothermally transformed to bainite. However, the transformation temperature was 310°C instead of 350°C. This resulted in a finer structure as expected. Again, retained austenite was present but generally on a much finer scale. Note that there are no carbides in this bainite, only ferrite and films of retained austenite. This form of bainite has been reported in the literature.

C. Fracture Morphology

The fracture morphology of both alloy 4340 and 300M were extensively examined. Mixed structures were present for nearly all heat treatment conditions. Figure 29a clearly shows the mixed ductile and cleavage modes present. Tempering reduces the amount of cleavage, Figure 29 b and c. The interface between the fatigue precrack and the initial crack growth region is visible in Figure 29c. In all cases only regions near

the fatigue crack were examined. The 1200°C/oil quench fracture morphology is shown in Figure 30a. The high magnification micrograph indicates shallow dimple type fracture indicating very localized plastic flow. Again both dimpled and quasicleavage areas were present. Step quenching to 870°C resulted in a somewhat more intergranular-fracture mode, Figure 30b.

Step quenching from 870°C to 315°C to form a duplex structure resulted in two distinct fracture modes, Figure 31a. However, additional tempering at 200°C eliminated the intergranular cleavage and also increased the fracture toughness somewhat. Recall, however, that the highest toughness was achieved by the direct quench from 1200°C, or by step quenching for very short times prior to oil quenching. Micrographs for the 1200 → 335°C step quench to form a duplex martensitic-bainitic structure are included in Figure 32. The transition from a ductile to a brittle fracture is obvious as the holding time at 335°C is increased from 1 minute to 1 hr.

It is difficult in some cases to identify morphology features which can be uniquely associated with either a high or low toughness level. Figure 33 contains micrographs from K_{IC} specimens which were stepped from 1200°C - 1100°C for 1 min (Fig. 33 a and b) and 1 hour (Fig. 33c). All three figures are similar in that they exhibit coarse intergranular features which reveal localized plastic flow along grain boundaries. However referring

to Table 3, it is seen that the toughness of 33 a & b is the toughness of 33c is very low.

Alloy 300M did not exhibit intergranular fracture in the large grained specimens, Figure 35. However, tempering produced a much more ductile fracture surface compared to the surface of an as quenched test specimen. For this case intergranular fracture can be associated with improved toughness. However, Figure 34b and 35b demonstrates that it is very difficult to judge the relative toughness of specimens by just examining the fracture surface. For this case both specimens exhibit a ductile failure mode.

D. Hardness Testing

A limited amount of hardness testing has been done, preliminary to tensile testing. This data is shown in Figures 34 and 35 for 4340 and 300M respectively. For the direct quench from 1200°C there was little change in hardness for either alloy. In each case the samples transformed for 60 minutes had a hardness due to the formation of a large amount of bainite rather than martensite. The choice of transformation temperatures was based on the transformation temperatures and was chosen in order to transform about 20% martensite. However, judging from the measured hardnesses the martensite may be lower than anticipated. Bainitic hardness levels appear to be obtainable. A series of transformation temperatures

during the second year program in order to establish the
that can be achieved by this method.

ing

V. DISCUSSION

The results of this program have demonstrated that very high toughness levels can be achieved. In fact, by direct quenching from 1200°C rather than step quenching, even higher levels of toughness can be achieved while maintaining very high strength levels. A unique explanation for the observed property changes is difficult to make based on microstructural analysis. Both the fine grain and the large grain size are martensitic products of direct quenching. Both contain lath and plate martensite. There are some variations in the amount of twinning in some cases, but any firm conclusions must wait until additional thin foils are examined for variations in the amount and morphology of the twins. Variations in the amount of retained austenite have been observed, but it is difficult to positively conclude that this is a factor for the improvement. The most informative results are the trends in toughness during step quenching, and the fact that 1200 and not 1100°C is necessary for maximum toughness. Electron microscopy will continue during the 2nd year effort on these samples in order to identify any variations in austenite and twin density. In addition to austenite and twin considerations, other microstructural possibilities are lath size and plate size both of which might control a critical fracture path length. Again, a large number of foils must be prepared and examined before conclusions can be reached. Electron microscopy will continue throughout the 2nd year in order to obtain sufficient data to make a meaningful evaluation.

There is one additional potential explanation which the data supports. Segregation of both the alloy elements such as nickel as well as trace level impurity elements may cause significant changes in the fracture toughness. The reduced toughness levels produced by step quenching support this theory, especially since increasing the holding time at either 1100°C or 870°C severely reduces the fracture toughness. It is important to note that at these intermediate step temperatures ranging from 870 to 1100°C, no precipitation, transformations, or grain growth occur. Thus in addition to variations in austenite content and morphology as well as variations in the substructure of the martensite, variations in segregation due to both grain size and step quench temperature and time are to be taken into account. Auger electron spectroscopy will be carried out during the second year in order to quantitatively establish the existence of segregation as a possible mechanism controlling the toughness of these alloys.

High temperature solution treatments alter the shape of the TTT curve for 4340 and silicon modified 4340. Figures 14-16 relate to the TTT curves for each alloy as a function of austenitizing temperature. A comparison of Figures 14 and 15 demonstrates the effect of the austenitizing temperature. Note that the M_s temperature increases about 25°C, and that the nose of the curve is retarded. This increases the upper bainitic hardenability. However, the kinetics of the lower bainitic transformation are essentially unchanged. Figure 16 is for a silicon modified 4340 with 1% silicon. The silicon content also affects the kinetics of the bainite reaction. For example, 4340 transformed

at 300°C requires 5 minutes to reach 70% transformation to bainite whereas with 1% silicon, one hour is required to produce 70% transformation. Figure 17 indicates the amount of austenite retained at any transformation temperature after the reaction has stabilized after a prior 900°C solution treatment.

The fracture toughness of each alloy isothermally transformed to bainite was not as high as the fracture toughness of the martensitic structures. This may be due to inherently lower toughness in the bainitic structure or it could relate to a segregation model again. Many studies have shown that as the carbon content is raised, the optimum structure for maximizing the toughness, goes from martensitic to bainitic. In general, the transition carbon level is about .4% by weight. Hence, both alloys are in the transition region. If, however, the austenite is stabilized by a supersaturation of carbon within the austenite, then the overall carbon content of the martensite may be lowered. This would be expected to improve the toughness of the martensite. However, one might also expect the strength to drop just on the basis of lower strength martensite.

The advantage of a short time step quench to just above the M_s temperature would be to reduce the thermal gradient prior to quenching through the martensite transformation range. In order to do this effectively, it is necessary to know how long it takes test specimens, or actual components, to reach the temperature of the bath. Work during the second year program will include instrumented quenching data in order to optimize the actual step quench time for several temperatures.

VI. SUMMARY & CONCLUSIONS

It appears for the work to date in this program that martensitic structures have better toughness than bainitic structures, even though bainitic structures tend to have more retained austenite. However, the bainitic structures produced to date have been fairly coarse and a further reduction in the isothermal transformation will be utilized in order to refine the structure and increase the strength of the bainitic structure.

The effects of step quenching over a range of temperatures for varied holding times have been demonstrated. A complete description of these effects will require additional testing as outlined in the second year program. A better understanding of the stability of the austenite under different conditions has been obtained. The stability of the retained austenite depends on both the amount of silicon present and the austenitizing temperature and quenching conditions. Additional work utilizing electron microscopy, X-ray diffraction and auger electron spectroscopy is required. This work will form part of the second year program. The primary results are the variations in the fracture toughness levels achieved by different heat treatments. These are summarized as follows:

- (1) For maximum toughness initial austenitization at 1200°C, was required.

- (2) Maximum toughness was obtained by using several different heat treatment schedules. In addition to the direct quench from 1200°C, step quench treatments to 1100, 870°C or 315°C all produced high toughness levels if the holding time was short.
- (3) The 1200°C/1 hr → 1100°C intermediate heat treatment produced interesting results relative to the importance of the 1200°C initial temperature. Note that upon holding for successively longer times at 1100°C, the toughness dropped from 91,370 psi-in^{1/2} for a 1 minute hold to 68,000 for a 30 minute hold for a 175°C temper.
- (4) For specimens held one hour at 315 or 335°C, the toughness, although severely reduced, is essentially independent of the prior austenitizing temperature.
- (5) Valid plane strain fracture toughness results of over 90,000 psi-in^{1/2} were achieved for alloy 4340 combined with tensile strengths of 300,000 psi. K_{IC} values of over 85,000 psi-in^{1/2} have been obtained for alloy 300M at equivalent strength levels.

ACKNOWLEDGEMENTS

The author gratefully acknowledges the assistance of Dr. K. Khan for electron microscopy analysis and J. Biskey for assistance with heat treating, mechanical testing and metallography. The assistance of S. Shankar and K. Datta during the testing and analysis of the data is also acknowledged.

This research was performed under the Department of the Navy, Naval Air Systems Command and Office of Naval Research, Washington, D.C., Contract No. N00019-76-C-0149

REFERENCES

1. Fracture toughness of high strength materials: Theory and Practice, Iron and Steel Inst. Special Publication No. 120, London, 1970.
2. Metal Progress Data Book _____ American Society for Metals, Metals Park, Ohio 1975.
3. V.F. Zackay, E.R. Parker, and W.E. Wood, Influence of some microstructural features on the fracture toughness of high strength steels. Third Int. Conf. on Strength of Metals and Alloys, Cambridge, England, Inst. of Metals, London, 1973, pp. 175-179.
4. G.Y. Lai, W.E. Wood, R.A. Clark, V.F. Zackay, and E.R. Parker, Met. Trans. 1974, Vol. 5, pp. 1663-1670.
5. R.D. Goolsby, W.E. Wood, E.R. Parker, V.F. Zackay, Electron Microscopy and Structure of Materials (Eds. G. Thomas, R.M. Fulrath, and R.M. Fisher - Univ. of California Press), 1972, pp. 798-807.
6. G.Y. Lai, Mat. Sci. and Eng. 1975, vol. 19, pp. 153-156.

Table 1

Fracture Toughness Data for Alloy 4340

| I.D. | Heat Treatment | | | K_{IC} psi-in ^{1/2} | K_{max} psi-in ^{1/2} | P_m/P_Q |
|-------|-------------------------------|--------|---------------------------|-----------------------------------|------------------------------------|-----------|
| | Austenitizing Temp. °C/hr. | Quench | Tempering Temp. °C/hr. | | | |
| AC2 | 870/1 | oil | AQ | 38,560 | 38,560 | 1.00 |
| AC14 | 870/1 | oil | AQ | 34,390 | 34,390 | 1.00 |
| AC18 | 870/1 | oil | AQ | 33,510 | 37,720 | 1.02 |
| A19 | 870/1 | oil | 125/1 hr | 42,240 | 42,240 | 1.00 |
| AC3 | 870/1 | oil | 200/1 hr | 61,460 | 67,920 | 1.04 |
| AC5 | 870/1 | oil | 200/1 hr | 64,600 | 64,600 | 1.00 |
| AC6 | 870/1 | oil | 280/1 hr | 77,470 | 88,180 | 1.03 |
| AC7 | 870/1 | oil | 280/1 hr | 75,120 | 80,560 | 1.03 |
| AC8 | 870/1 | oil | 350/1 hr | 92,630 | 113,33 | 1.12* |
| AC9 | | | 350/1 hr | 103,290 | 117,810 | 1.05 |
| ----- | | | | | | |
| AC12 | 1100/1 | oil | AQ | 42,970 | 42,970 | 1.00 |
| AC13 | 1100/1 | oil | AQ | 43,130 | 43,130 | 1.00 |
| AC53 | 1100/1 | oil | 125/1 | 45,620 | 50,760 | 1.07 |
| AC27 | 1100/1 | oil | 175/1 | 58,170 | 61,960 | 1.01 |
| AC26 | 1100/1 | oil | 175/1 | 61,110 | 63,670 | 1.01 |
| AC28 | 1100/1 | oil | 200/1 | 61,440 | 61,440 | 1.00 |
| ----- | | | | | | |
| AC15 | 1200/1 | oil | AQ | 67,300 | 79,560 | 1.11 |
| AC22 | 1200/1 | oil | AQ | 46,780 | 62,870 | 1.18* |
| AC30 | 1200/1 | oil | AQ | 65,880 | 76,400 | 1.07 |
| AC24 | 1200/1 | oil | 125/1 | 83,074 | 89,660 | 1.04 |
| AC25 | 1200/1 | oil | 125/1 | 83,990 | 83,990 | 1.00 |
| AC23 | 1200/1 | oil | 225/1 | 66,360 | 85,090 | 1.17* |

Table 1 (cont'd)

Fracture Toughness Data for Alloy 4340

| I.D. | Heat Treatment | | Tempering Temp. °C/hr. | K_{IC} psi-in ^{1/2} | K_{max} psi-in ^{1/2} | P_m/P_Q |
|-------|-------------------------------|--------|---------------------------|-----------------------------------|------------------------------------|-----------|
| | Austenitizing Temp. °C/hr. | Quench | | | | |
| AC29 | 1200/1 | oil | 175/1 | 85,350 | 98,390 | 1.08 |
| AC31 | 1200/1 | oil | 280/1 | 59,580 | 70,070 | 1.08 |
| AC54 | 1200/1 | oil | 350/1 | 72,610 | 91,520 | 1.11* |
| AC55 | 1200/1 | oil | | 80,790 | 81,900 | 1.01 |
| ----- | | | | | | |
| AC47 | 1200/1-870/1/2hr | oil | AQ | 51,660 | 53,580 | 1.01 |
| AC51 | 1200/1-870/1/2hr | oil | AQ | 52,970 | 63,410 | 1.10 |
| AC48 | 1200/1-870/1/2hr | oil | 175/1 | 65,540 | 70,680 | 1.01 |
| AC49 | 1200/1-870/1/2hr | oil | 175/1 | 60,960 | 72,410 | 1.12* |
| AC37 | 1200/1-870/1/2hr | oil | 200/1 | 60,720 | 82,830 | 1.13* |
| AC38 | 1200/1-870/1/2hr | oil | 200/1 | 60,970 | 70,640 | 1.08* |
| ----- | | | | | | |
| AC41 | 1200/1-870/1/2hr | oil | 280/1 | 52,250 | 58,080 | 1.06 |
| AC42 | 1200/1-870/1/2hr | oil | 280/1 | 52,970 | 59,120 | 1.06 |
| AC44 | 1200/1-870/1/2hr | oil | 350/1 | 85,640 | 96,060 | 1.01 |
| AC45 | 1200/1-870/1/2hr | oil | 350/1 | 84,730 | 96,300 | 1.06 |
| AC43 | 1200/1-870/1/2hr | oil | 150/1 | 59,370 | 68,770 | 1.06 |
| ----- | | | | | | |
| AC46 | 1200/1-870/1 hr | oil | AQ | 52,890 | 55,960 | 1.03 |
| ----- | | | | | | |
| AC50 | 1200/1-870/5 min | oil | AQ | | | |
| AC52 | 1200/1-870/5 min | oil | AQ | 56,660 | 67,210 | 1.11* |
| ----- | | | | | | |
| AC39 | 1200/1-870/30 sec | oil | AQ | 62,620 | 75,380 | 1.11* |
| AC40 | 1200/1-870/30 sec | oil | AQ | 64,960 | 74,210 | 1.10 |

Table 1 (cont'd)
Fracture Toughness Data for Alloy 4340

| I.D. | Austenitizing Temp. °C/hr. | Quench | Tempering Temp. °C/hr. | K_{IC} psi-in ^{1/2} | K_{max} psi-in ^{1/2} | P_m/P_Q |
|-------|-------------------------------|--------|---------------------------|-----------------------------------|------------------------------------|-----------|
| AC56 | 870/1→315/3 min | oil | AQ | 40,340 | 48,070 | 1.10 |
| AC57 | | oil | | 39,430 | 45,510 | 1.07 |
| AC58 | | | 200/1 | 51,400 | 54,540 | 1.03 |
| AC59 | | | | 52,960 | 58,980 | 1.03 |
| AC60 | 870/1→315/60 min | oil | AQ | 49,540 | 59,630 | 1.04 |
| AC61 | | | | 52,480 | 63,100 | 1.06 |
| AC62 | | | 200/1 | 57,160 | 66,830 | 1.09 |
| AC63 | | | | 58,590 | 62,430 | 1.02 |
| ----- | | | | | | |
| AC82 | 1200/1→300/3 min | oil | 200/1 | 79,240 | 88,800 | 1.05 |
| AC83 | | | | 80,400 | 84,730 | 1.03 |
| AC80 | 1200/1→300/60 min | oil | 200/1 | 62,530 | 62,530 | 1.00 |
| AC81 | | | | 65,370 | 65,370 | 1.00 |
| AC87 | 1200/1→315/10 sec | oil | 175/1 | 90,220 | 100,830 | 1.04 |
| AC84 | | | | 88,420 | 93,410 | 1.02 |
| AC85 | | | | 88,150 | 99,880 | 1.08 |
| AC72 | 1200/1→335/1 min | oil | 200/1 | 89,690 | 94,590 | 1.02 |
| AC64 | 1200/1→335/3 min | oil | AQ | 58,150 | 66,280 | 1.06 |
| AC65 | | | | 60,480 | 66,830 | 1.03 |
| AC73 | | | 175/1 | 80,220 | 82,110 | 1.01 |
| AC70 | | | 200/1 | 74,460 | 82,730 | 1.03 |
| AC71 | | | | 78,240 | 79,670 | 1.00 |
| AC74 | | | 280/1 | 68,490 | 81,430 | 1.06 |
| AC75 | 1200/1→335/5 min | oil | 200/1 | 82,670 | 88,670 | 1.01 |

Table 1 (cont'd)

Fracture Toughness Data for Alloy 4340

| I.D. | Austenitizing Temp. °C/hr. | Quench | Tempering Temp. °C/hr. | K_{IC} psi-in ^{1/2} | K_{max} psi-in ^{1/2} | P_m/P_Q |
|-------|-------------------------------|--------|---------------------------|-----------------------------------|------------------------------------|-----------|
| AC66 | 1200/1-335/60 min | oil | AQ | 43,490 | 50,720 | 1.08 |
| AC67 | | | | 45,890 | 45,890 | 1.00 |
| AC68 | | | 200/1 | 53,930 | 58,050 | 1.01 |
| AC69 | | | | 47,160 | 57,390 | 1.10 |
| AC79 | | | | 50,530 | 58,450 | 1.04 |
| ----- | | | | | | |
| AC86 | 1200/1-1100/1 min | oil | 175/1 | 91,370 | 101,040 | 1.05 |
| AC88 | | | 200/1 | 85,710 | 100,020 | 1.06 |
| AC89 | 1200/1-1100/10 min | oil | 175/1 | 93,460 | 107,610 | 1.05 |
| AC34* | | | 200/1 | 67,880 | 77,430 | 1.05 |
| AC32 | 1200/1-1100/30 min | oil | 200/1 | 72,050 | 76,510 | 1.02 |
| AC33 | | | 200/1 | 63,040 | 69,090 | 1.03 |
| ----- | | | | | | |
| AC76 | 1150/1 | oil | AQ | 50,690 | 53,130 | 1.01 |
| AC77 | | | | 53,710 | 57,300 | 1.04 |
| AC78 | | | 175/1 | 70,070 | 76,410 | 1.04 |

*Possible variation in holding time at 1100°C. Additional tests to be carried out.

Table 2

Fracture Toughness Data for Alloy 300M

| I.D. | Heat Treatment | | Tempering Temp. °C/hr. | K_{IC} psi-in ^{1/2} | K_{max} psi-in ^{1/2} | P_m/P_Q |
|-------|-------------------------------|--------|---------------------------|-----------------------------------|------------------------------------|-----------|
| | Austenitizing Temp. °C/hr. | Quench | | | | |
| BC7 | 870/1 | oil | AQ | 36,520 | 54,090 | 1.13* |
| BC8 | 870/1 | oil | AQ | 36,480 | 53,550 | 1.11* |
| BC39 | 870/1 | oil | 175/1 | 68,450 | 80,865 | 1.01 |
| BC10 | 870/1 | oil | 200/1 | 67,980 | 78,930 | 1.02 |
| BC28 | 870/1 | oil | 200/1 | 65,490 | 76,860 | 1.02 |
| BC11 | 870/1 | oil | 280/1 | 63,850 | 75,380 | 1.03 |
| BC29 | 870/1 | oil | 280/1 | 66,600 | 73,850 | 1.02 |
| BC30 | 870/1 | oil | 350/1 | 67,950 | 75,260 | 1.03 |
| BC38 | 870/1 | oil | 125/1 | 45,940 | 62,410 | 1.07 |
| BC27 | 870/1 | oil | 150/1 | 44,640 | 58,150 | 1.05 |
| ----- | | | | | | |
| BC14 | 1100/1 | oil | AQ | 39,790 | 60,610 | 1.18* |
| BC13 | 1100/1 | oil | AQ | 42,820 | 61,760 | 1.13* |
| BC45 | 1100/1 | oil | 175/1 | 76,500 | 93,050 | 1.05 |
| BC31 | 1100/1 | oil | 200 | 76,300 | 93,460 | 1.05 |
| BC32 | 1100/1 | oil | 280 | 72,260 | 95,330 | 1.06 |
| BC33 | 1100/1 | oil | 350 | 72,570 | 87,930 | 1.08 |
| ----- | | | | | | |
| BC15 | 1200/1 | oil | AQ | 43,670 | 55,330 | 1.02 |
| BC16 | 1200/1 | oil | AQ | 39,720 | 65,270 | 1.22* |
| BC37 | 1200/1 | oil | 125/1 | 53,010 | 75,200 | 1.07 |
| BC48 | 1200/1 | oil | 125/1 | 53,350 | 76,320 | 1.08 |
| BC49 | 1200/1 | oil | 150/1 | 59,480 | 81,310 | 1.08 |
| BC40 | 1200/1 | oil | 175/1 | 89,540 | 107,390 | 1.05 |
| BC46 | 1200/1 | oil | 175/1 | 77,670 | 106,060 | 1.13* |

Table 2 (cont'd)

Fracture Toughness Data for Alloy 300M

| I.D. | Heat Treatment | | Tempering Temp. °C/hr. | $K_{IC}^{1/2}$ psi-in ^{1/2} |
|-------|-------------------------------|--------|---------------------------|-----------------------------------------|
| | Austenitizing Temp. °C/hr. | Quench | | |
| BC17 | 1200/1 | oil | 200/1 | 80,140 |
| BC18 | 1200/1 | oil | 200/1 | 85,530 |
| BC35 | 1200/1 | oil | 200/1 | 82,810 |
| BC19 | 1200/1 | oil | 280/1 | 78,080 |
| BC36 | 1200/1 | oil | 280/1 | 83,630 |
| BC20 | 1200/1 | oil | 350/1 | 73,930 |
| ----- | | | | |
| BC41 | 1200/ 1/2 hr | oil | 200/5 | 79,370 |
| BC42 | 1200/ 1/2 hr | oil | 200/5 | 79,120 |
| ----- | | | | |
| BC43 | 1200/ 1/4 hr | oil | 200/5 | 89,000 |
| BC44 | 1200/ 1/4 hr | oil | 200/5 | 85,720 |
| BC47 | 1200/ 1/4 hr | oil | 200/1 | 88,970 |
| ----- | | | | |
| BC21 | 1200/1→870/ 1/2 hr | oil | AQ | 42,560 |
| BC22 | 1200/1→870/ 1/2 hr | oil | AQ | 41,680 |
| BC23 | 1200/1→870/ 1/2 hr | oil | 200/1 | 75,670 |
| BC24 | 1200/1 870/ 1/2 hr | oil | 200/1 | 79,010 |
| BC25 | 1200/1→870/ 1/2 hr | oil | 280/1 | 72,440 |
| BC26 | 1200/1→870/ 1/2 hr | oil | 350/1 | 66,000 |

Table 2 (cont'd)

Fracture Toughness Data for Alloy 300M

| I. D. | Austenitizing Temp. °C/hr. | Quench | Tempering Temp. °C/hr | K _{IC} psi-in |
|-------|-------------------------------|----------------|--------------------------|---------------------------|
| BC52 | 870/1 | 315/3 min oil | AQ | |
| BC53 | | | 200/1 | 67,270 |
| BC50 | 870/1 | 315/60 min oil | AQ | 43,200 |
| BC51 | | | 200/1 | 60,730 |
| ----- | | | | |
| BC56 | 1200/1 | 315/3 min oil | AQ | 49,570 |
| BC34 | | | 200/1 | 84,050 |
| BC54 | 1200/1 | 315/60 min oil | AQ | 46,730 |
| BC55 | | | 200/1 | 61,630 |

*invalid test result.

TABLE 3 Fracture Toughness versus Heat Treatment for Alloy 4340

| Austenitizing Temperature °C (for 1 hour) | Intermediate Holding Temperature °C | Final Tempering Temperature °C (for 1 hour) | Plane Strain Fracture Toughness, K _{IC} (Average Values) | | | | | | | |
|-------------------------------------------|-------------------------------------|---------------------------------------------|-------------------------------------------------------------------|--------|--------|--------|---------|---------|---------|--------|
| | | | 10 sec. | 1 min. | 3 min. | 5 min. | 10 min. | 30 min. | 60 min. | |
| 1200 | 300 | As quenched | | | | | | | | |
| | | 200 | | | 79,820 | | | | | |
| | 315 | 175 | 90,200 | | | | | | | |
| | | 200 | 88,280 | | | | | | | |
| | 335 | As quenched | | | | | | | | |
| | | 175 | | 59,320 | | | | | | 44,690 |
| 35 | 1100 | 200 | | 89,690 | 76,350 | 82,460 | | | | 50,540 |
| | | 280 | | | 68,490 | | | | | |
| | 315 | 175 | | 91,370 | | | | 93,460 | 68,000 | |
| | | 200 | | 85,710 | | | | 67,880* | | 67,000 |
| 870 | 315 | As quenched | | | | | | | | |
| | | 200 | | | 39,890 | | | | | 51,010 |
| | | | | | 52,180 | | | | | 57,880 |

*Possible error in heat treatment process, additional samples to be tested.

TABLE 4 Fracture Toughness versus Heat Treatment for Alloy 300M

| Austenitizing Temperature °C (for 1 hour) | Intermediate Holding Temperature °C | Final Tempering Temperature °C (for 1 hour) | Plane Strain Fracture Toughness, K_{Ic} (Average Values) | | | | | | |
|-------------------------------------------|-------------------------------------|---------------------------------------------|------------------------------------------------------------|--------|--------|--------|---------|---------|---------|
| | | | 10 sec. | 1 min. | 3 min. | 5 min. | 10 min. | 30 min. | 60 min. |
| 870 | 315 | As quenched 200 | | | | | | | 43,200 |
| | | | | | 67,270 | | | | 60,730 |
| 1200 | 315 | As quenched 200 | | | | | | | 47,730 |
| | | | | | 49,570 | | | | 61,650 |

FIGURE

- 1 Fracture toughness vs heat treatment response, tested in the as quenched condition.
- 2 Fracture toughness versus tempering temperature for alloy 4340.
- 3 Fracture toughness versus tempering temperature for alloy 4340.
- 4 Composite of Figures 2 and 3.
- 5 Fracture toughness versus tempering temperature for alloy 300M.
- 6 Fracture toughness versus tempering temperature for alloy 300M.
- 7 Composite of Figures 5 and 6.
- 8 Fracture toughness of 300M and 4340 after a standard 870°C solutioning treatment.
- 9 Fracture toughness of 300M and 4340 after a 1200°C solutioning treatment.
- 10 Yield strength vs plane strain fracture toughness for several commercial alloy steels.
- 11 Ultimate tensile strength vs plane strain fracture toughness for several commercial alloy steels.
- 12 Hardness vs tempering temperature for alloy 4340.
- 13 Hardness vs tempering temperature for alloy 300M.
- 14 Isothermal transformation curve for alloy 4340 austenitized at 900°C.
- 15 Isothermal transformation curve for alloy 4340 austenitized at 1200°C.
16. Isothermal transformation curve for alloy 4340 + 1% Si austenitized at 900°C.
17. Reaction temperature vs. percent retained austenite for Si modified 4340 steel.

FIGURE

- | | | |
|----|-------------|------------------------------------------------------------------------------------------------------------------------------------------------------------------------------------------|
| 18 | <u>4340</u> | (a) As received (b) 870°C/1 hr and oil quenched (c) 1200°C/1 hr and oil quenched (d) 1200°C/1 hr - 870°C/1/2 hr and oil quenched |
| 19 | <u>4340</u> | (a-c) 870°C/1 hr - 315°C/3 min and oil quenched |
| 20 | <u>4340</u> | 1200°C/1 hr - 335°C/3 min and oil quenched (a) As quenched (b) Tempered at 200°C/1 hr |
| 21 | <u>300M</u> | (a) As received (b, c) 870°C/1 hr and oil quenched (d) 1200°C/1 hr and oil quenched |
| 22 | <u>300M</u> | (a) 870°C/1 hr - 315°C/3 min and oil quenched (b) 1200°C/1 hr - 315°C/3 min and oil quenched |
| 23 | <u>300M</u> | 870°C/1 hr - 310°C/1 hr and oil quenched (a) As quenched (b) Tempered at 200°C/1 hr 1200°C/1 hr - 315°C/1 hr and oil quenched (c) As quenched (d) Tempered at 200°C/1 hr. |
| 24 | <u>4340</u> | Bright field TEM micrographs (a, b) 870°C/1 hr and oil quenched (c-f) 1200°C/1 hr - 1100°C/10 min, oil quenched, and tempered at 200°C/1 hr |
| 25 | <u>4340</u> | Bright field TEM micrographs (a-d) 1200°C/1 hr - 1100°C/30 min, oil quenched, and tempered at 200°C/1 hr. (e) Diffraction pattern of twinned region. |
| 26 | <u>300M</u> | TEM micrographs 1200°C/1 hr and oil quenched (a-c) Bright field (d) Dark field (e) Diffraction pattern |

FIGURE

- 27 300M TEM micrographs
870°C/1 hr - 350°C/1 hr and oil quenched
(a-c) Bright field
(d) Diffraction pattern of circled region on (b)
(e) Schematic of diffraction pattern
- 28 300M TEM micrographs
870°C/1 hr - 310°C/1 hr and oil quenched
(a,b) Bright field
(c) Diffraction pattern of circled region on (b)
(d) Schematic of diffraction pattern
- 29 4340 SEM fractographs
870°C/1 hr and oil quenched
(a) As quenched
(b) Tempered at 200°C/1 hr
(c) Tempered at 350°C/1 hr
- 30 4340 SEM fractographs
(a) 1200°C/1 hr, oil quenched and tempered at 175°C /1 hr
(b,c) 1200°C/1 hr - 870°C/30 min and oil quenched
- 31 4340 SEM fractographs
870°C/1 hr - 315°C/3 min and oil quenched
(a) As quenched
(b) Tempered at 200°C
- 32 4340 SEM fractographs
(a) 1200°C/1 hr - 335°C/1 min, oil quenched, and
tempered at 200°C/1 hr
(b) 1200°C/1 hr - 335°C/3 min, oil quenched, and
tempered at 200°C/1 hr
(c) 1200°C/1 hr - 335°C/60 min, oil quenched, and
tempered at 200°C/1 hr
- 33 4340 SEM fractographs
1200°C/1 hr - 1100°C/1 min and oil quenched
(a) Tempered at 175°C/1 hr
(b) Tempered at 200°C/1 hr
1200°C/1 hr - 1100°C/1 hr and oil quenched
(c) Tempered at 200°C/1 hr

FIGURE

- 34 300M SEM fractographs
 870°C/1 hr and oil quenched
 (a) As quenched
 (b) Tempered at 200°C/1 hr
- 35 300M SEM fractographs
 1200°C/1 hr and oil quenched
 (a) As quenched
 (b) Tempered at 200°C/1 hr

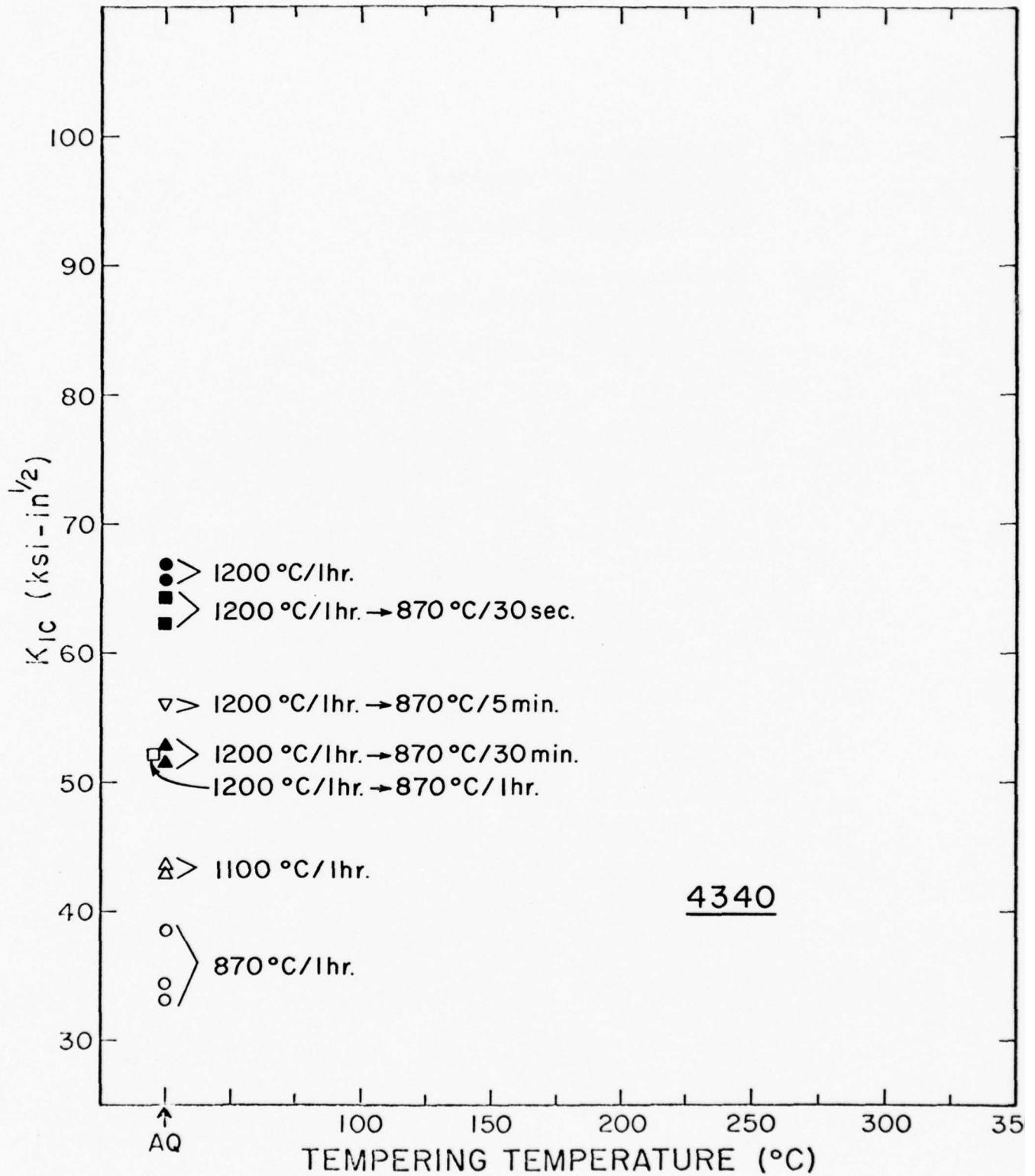

Figure 1. Fracture toughness vs. heat treatment response, tested in the as quenched condition.

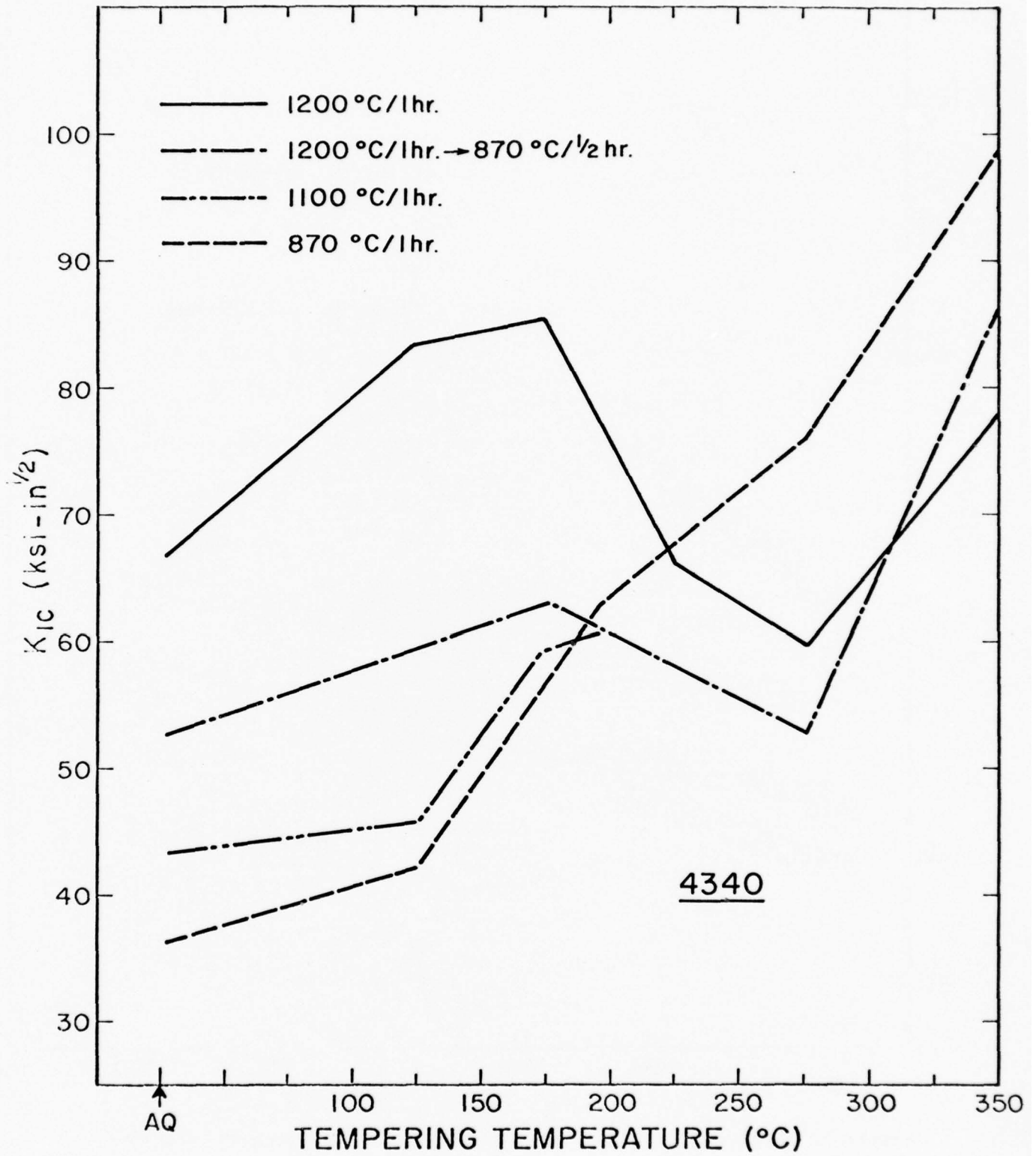

Figure 2. Fracture toughness versus tempering temperature for alloy 4340.

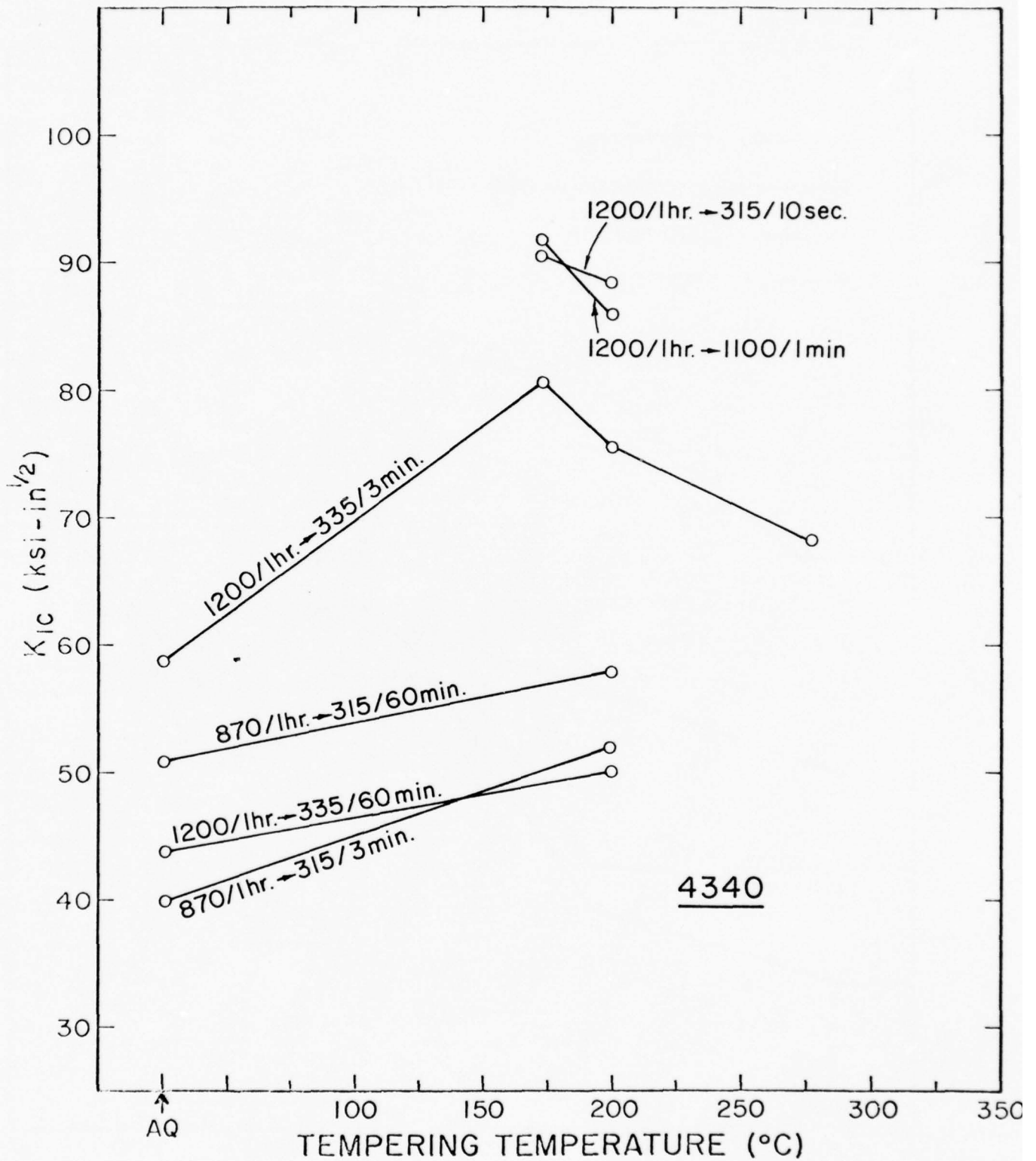

Figure 3. Fracture toughness versus tempering temperature for alloy 4340.

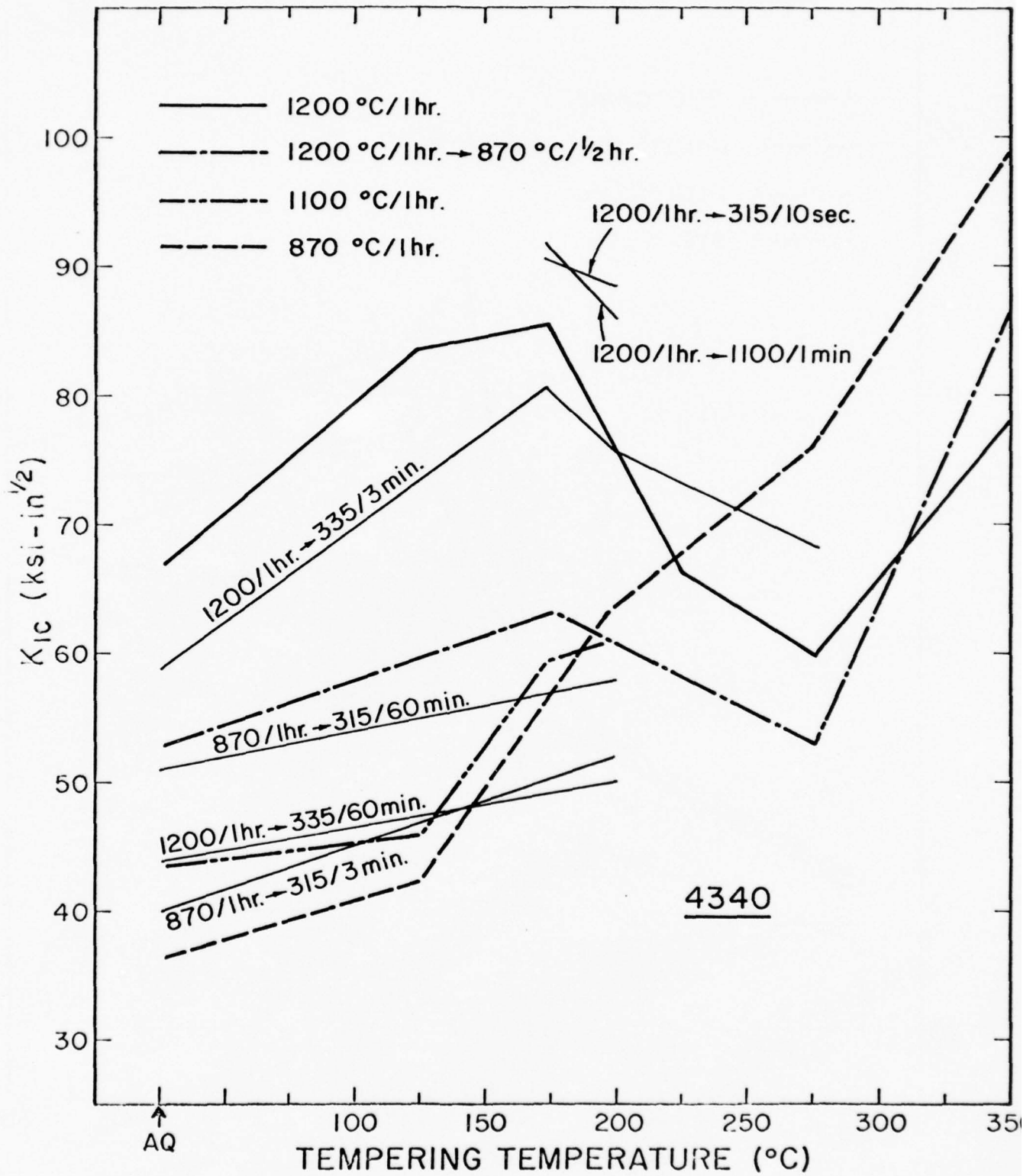

Figure 4. Composite of Figures 2 and 3.

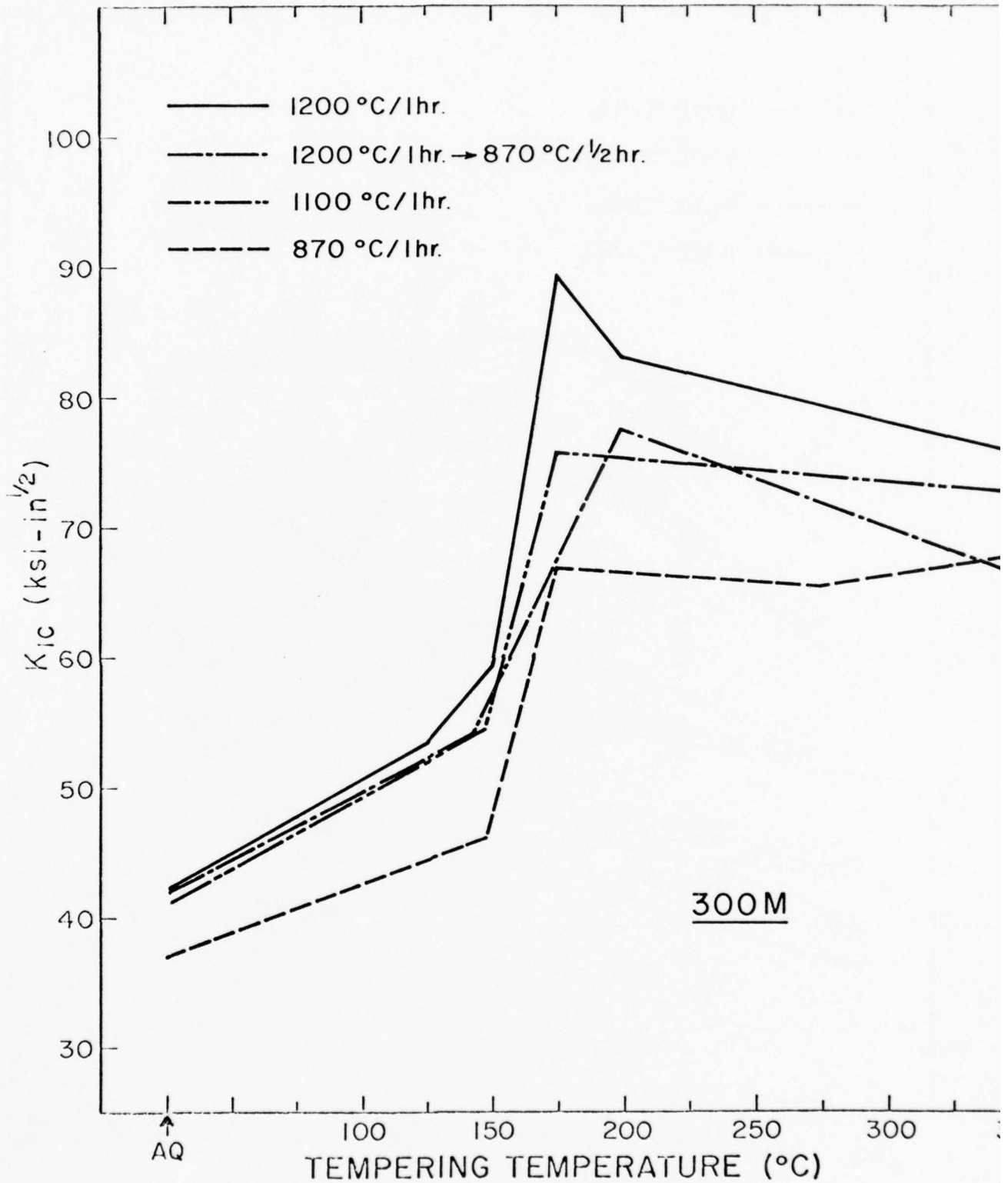

Figure 5. Fracture toughness versus tempering temperature for alloy 300M.

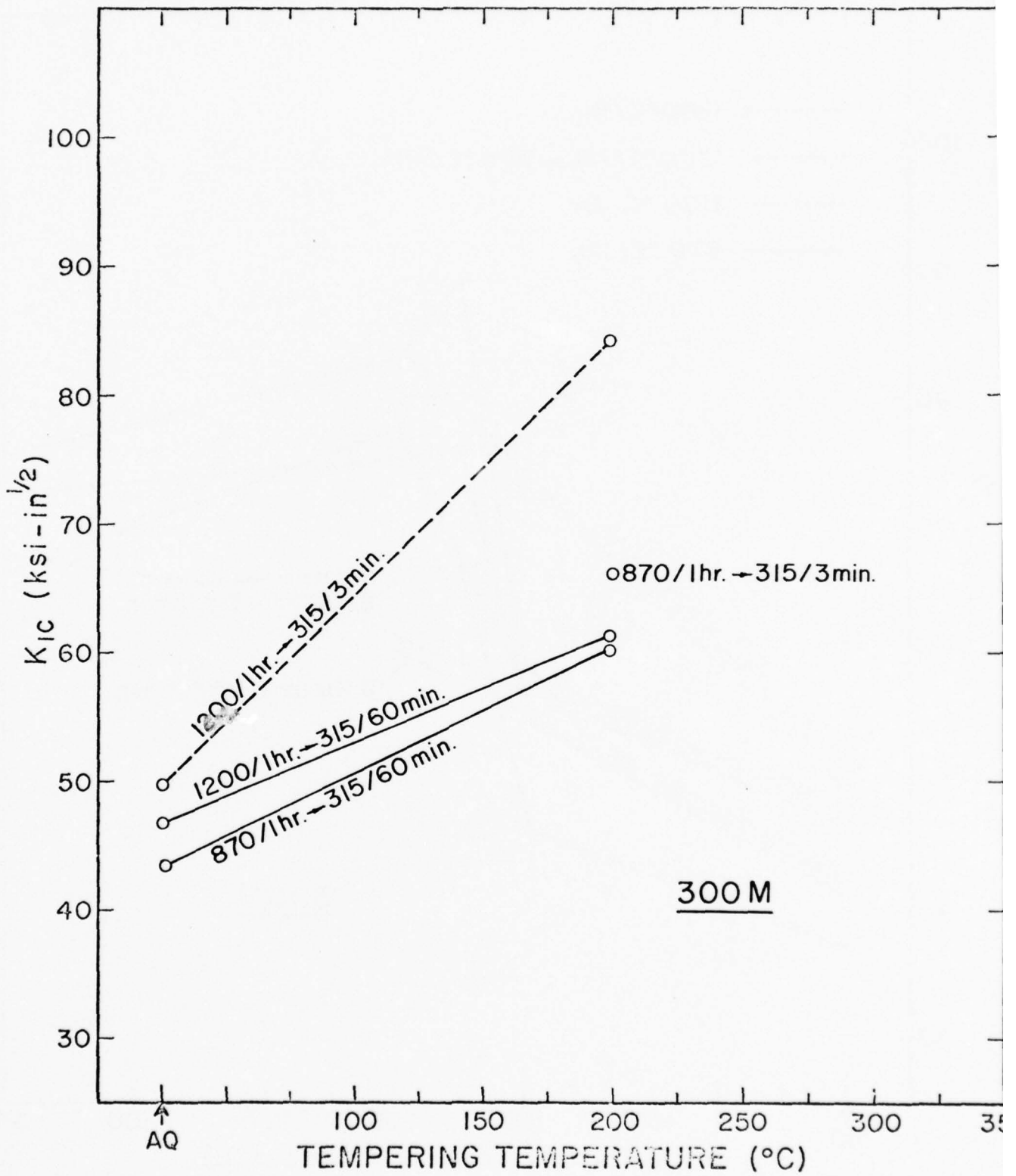

Figure 6. Fracture toughness versus tempering temperature for alloy 300M.

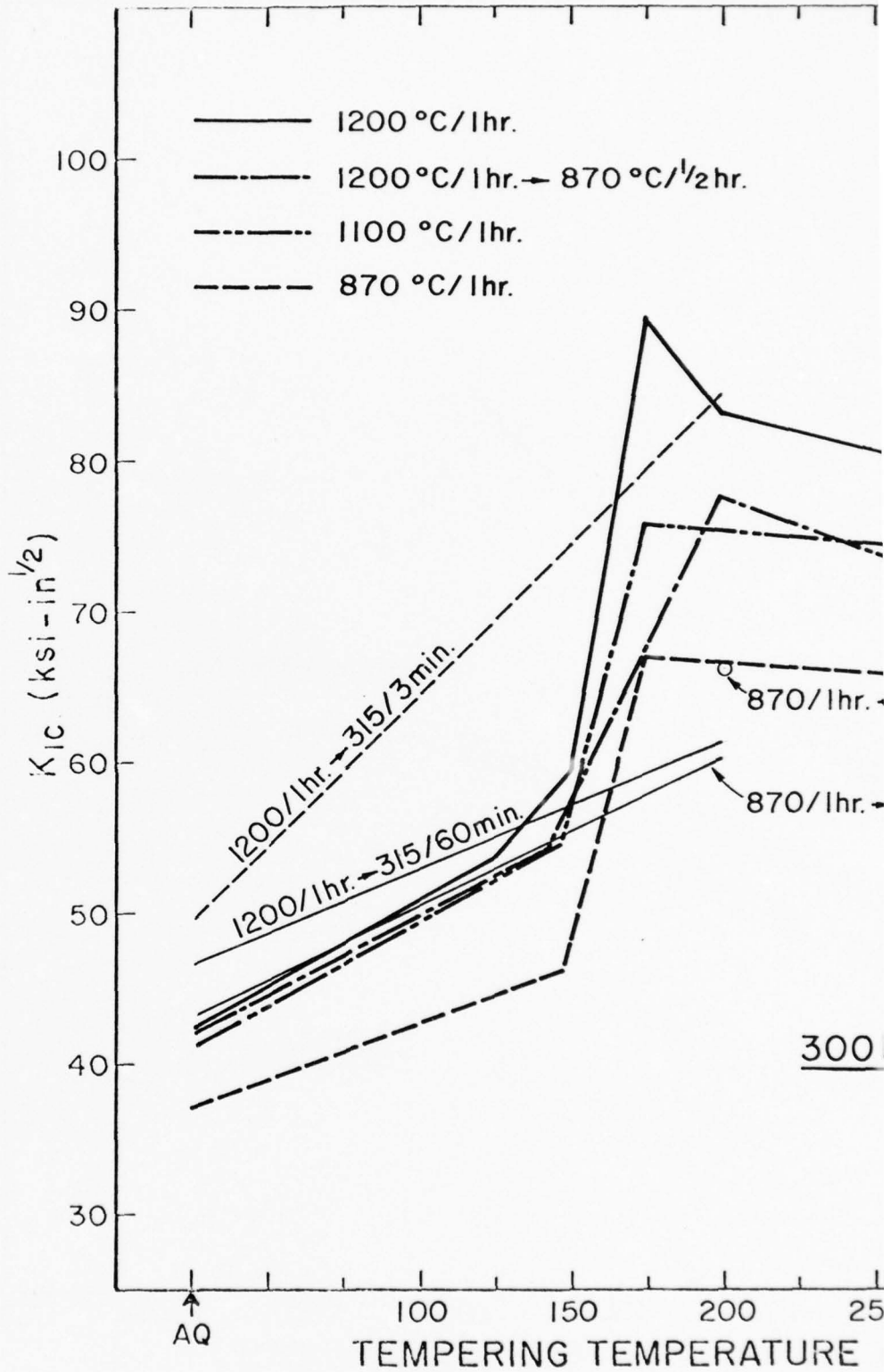

Figure 7. Composite of Figures 5 and 6.

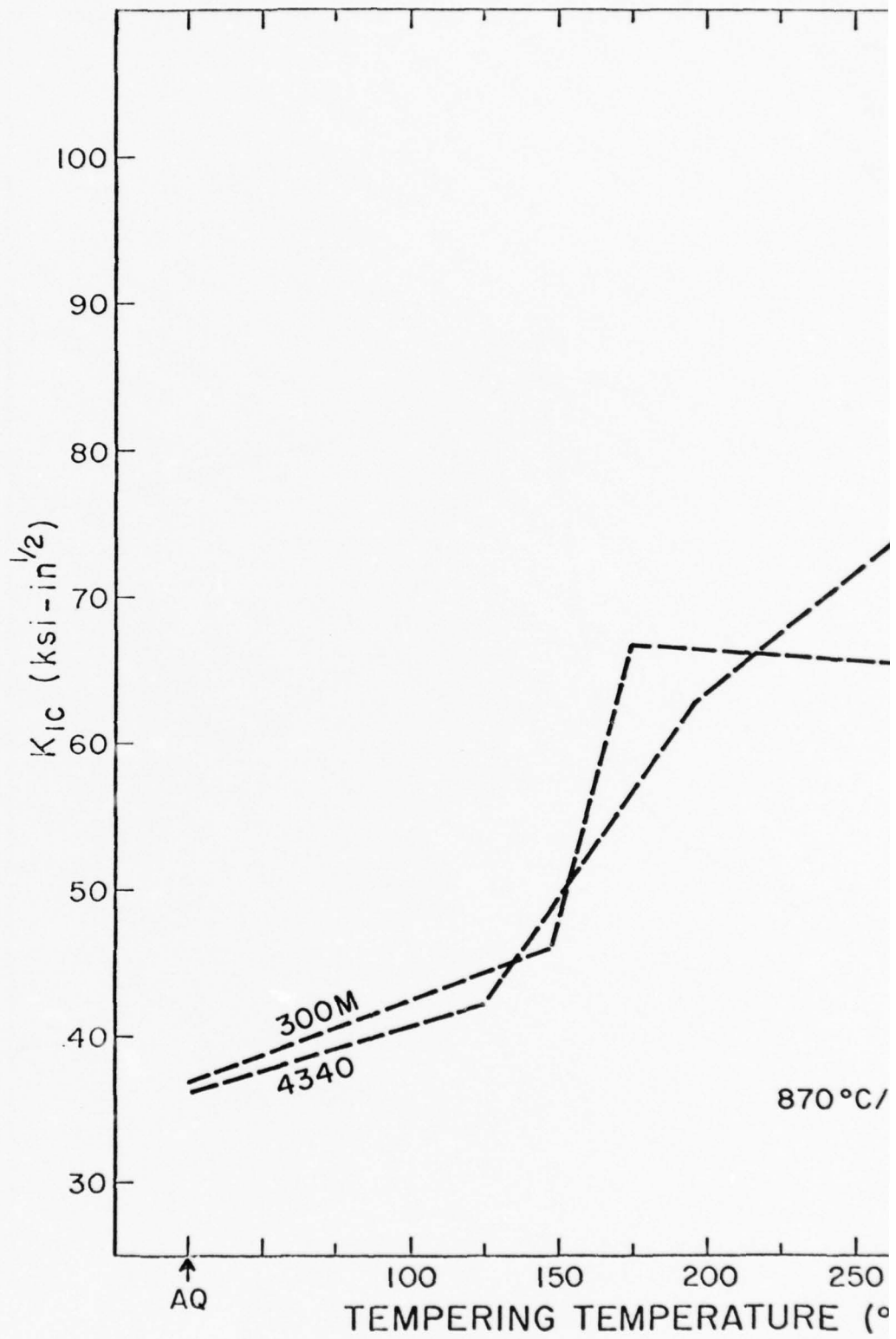

Figure 8. Fracture toughness of 300M and 4340 after a standard solutioning treatment.

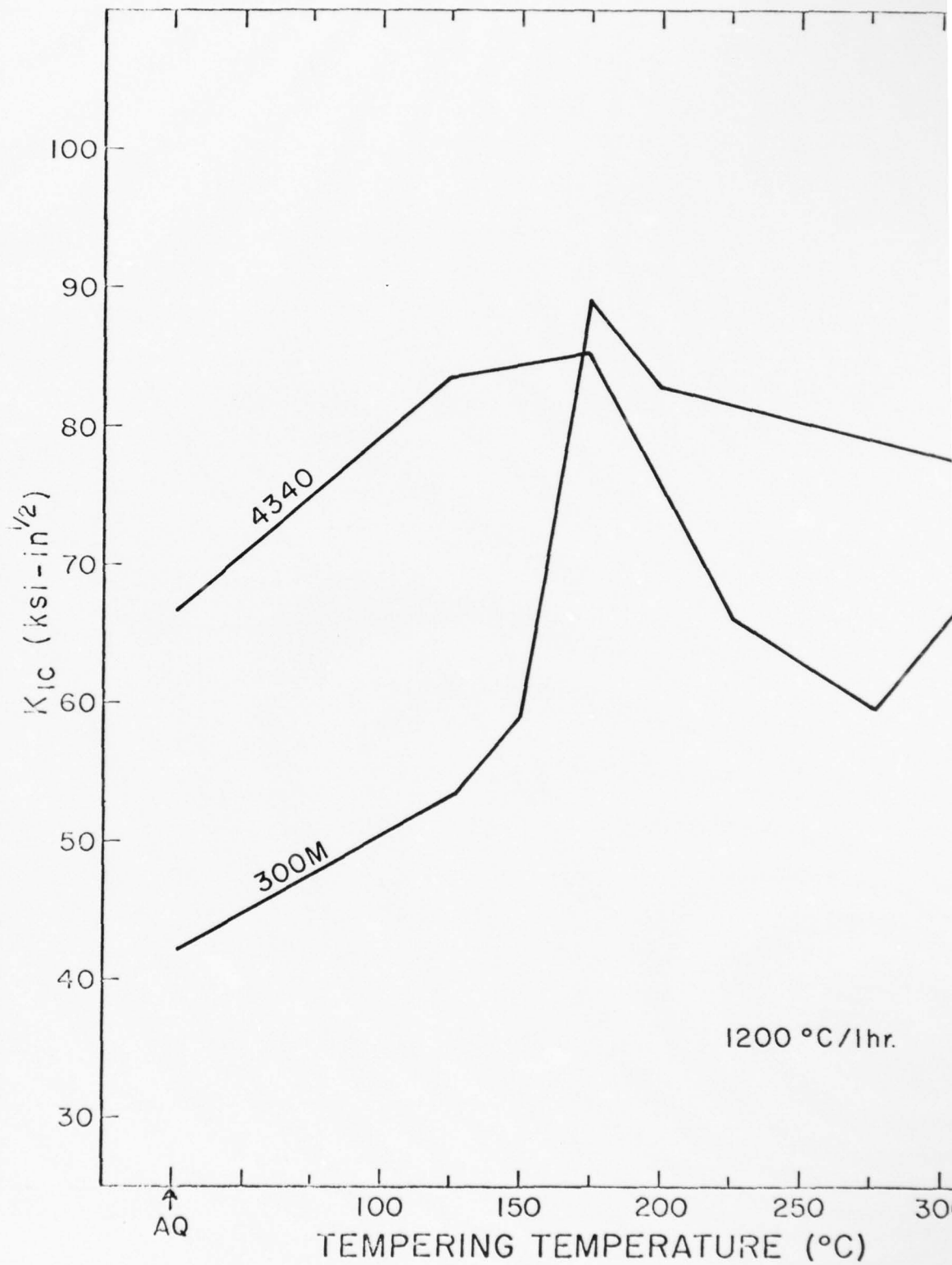

Figure 9. Fracture toughness of 300M and 4340 after a 1200°C solution treatment.

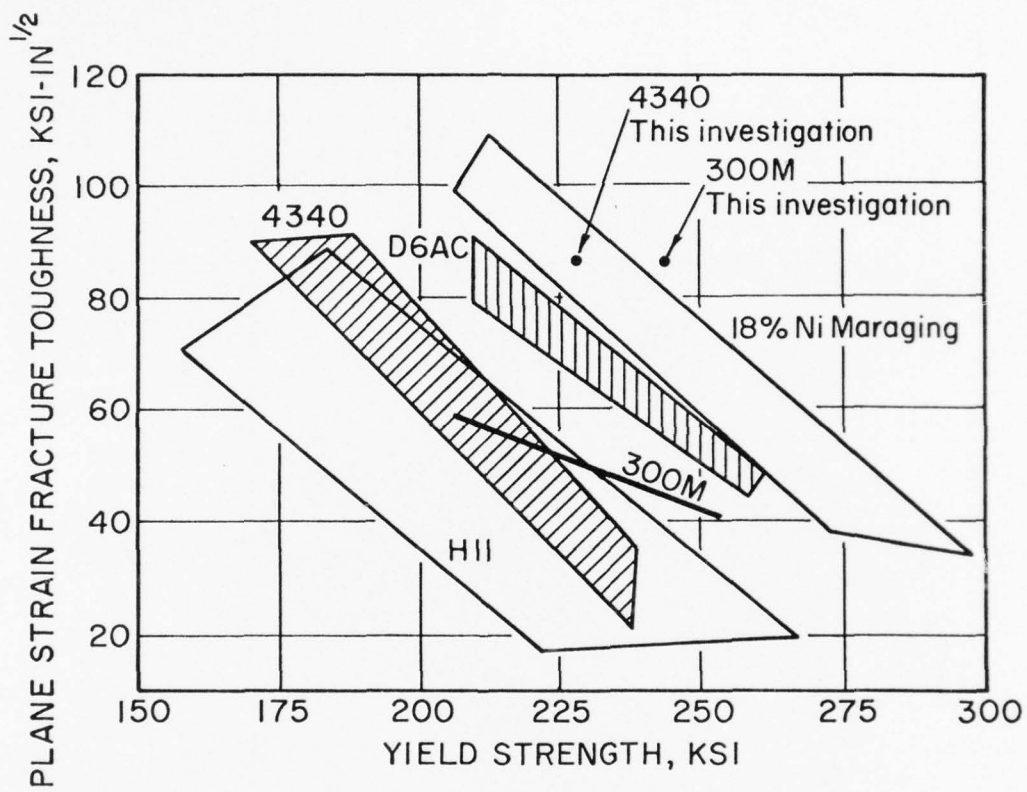

Figure 10. Yield Strength vs. plane strain fracture toughness for several commercial alloy steels.

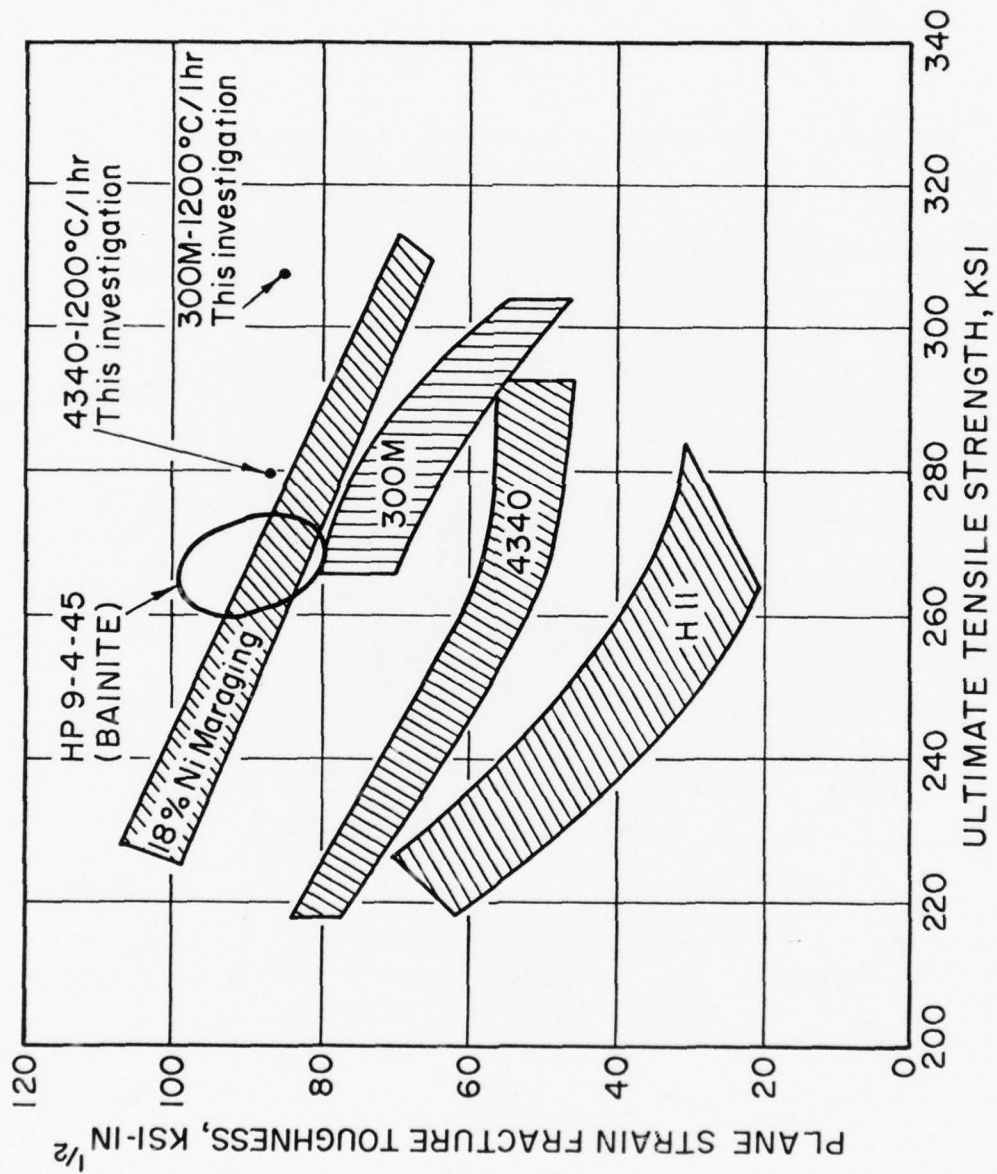

FIGURE 11. Ultimate tensile strength vs plane strain fracture toughness for several commercial alloy steels.

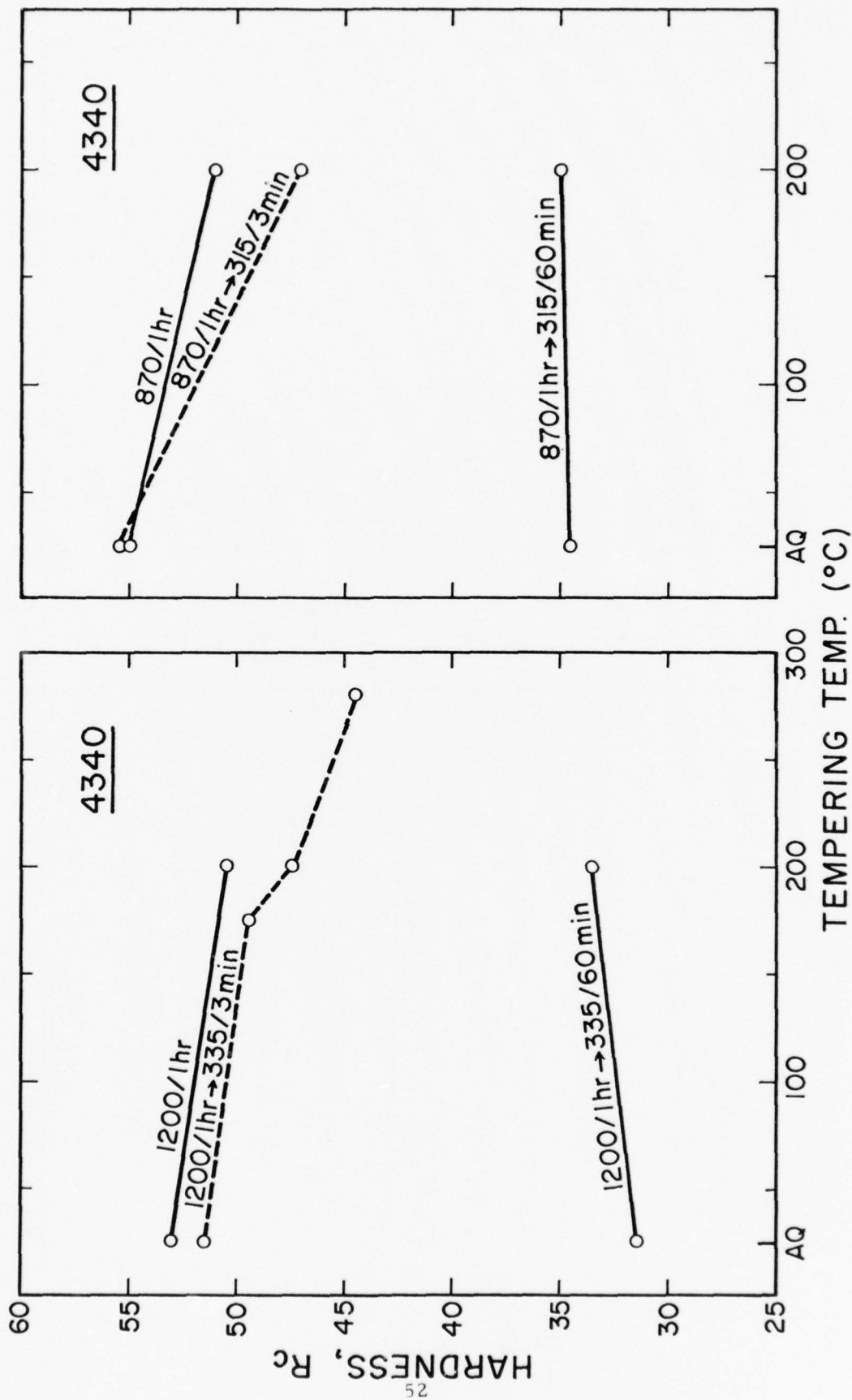

Figure 12. Hardness vs tempering temperature for alloy 4340.

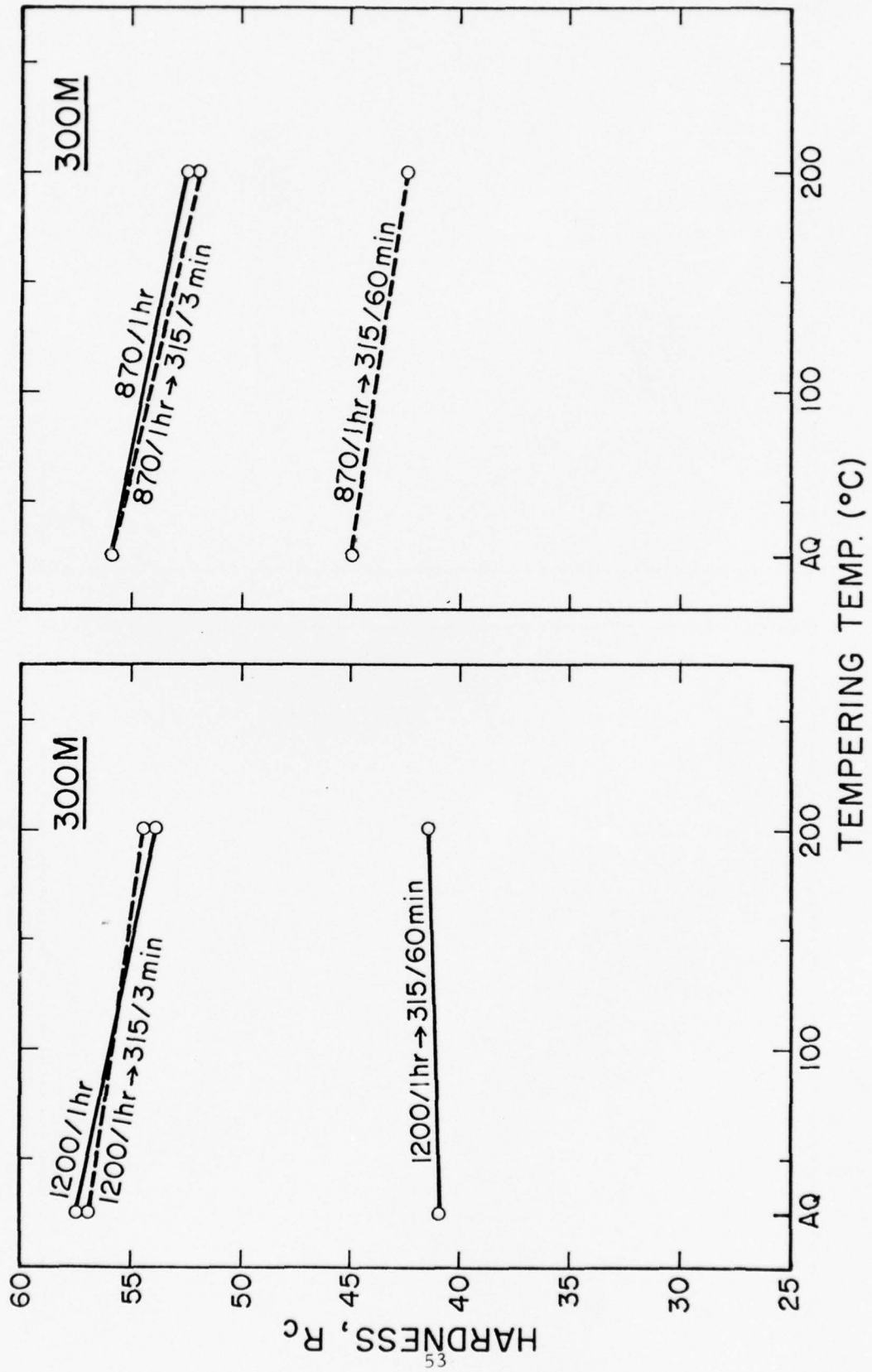

Figure 13. Hardness vs tempering temperature for alloy 300M.

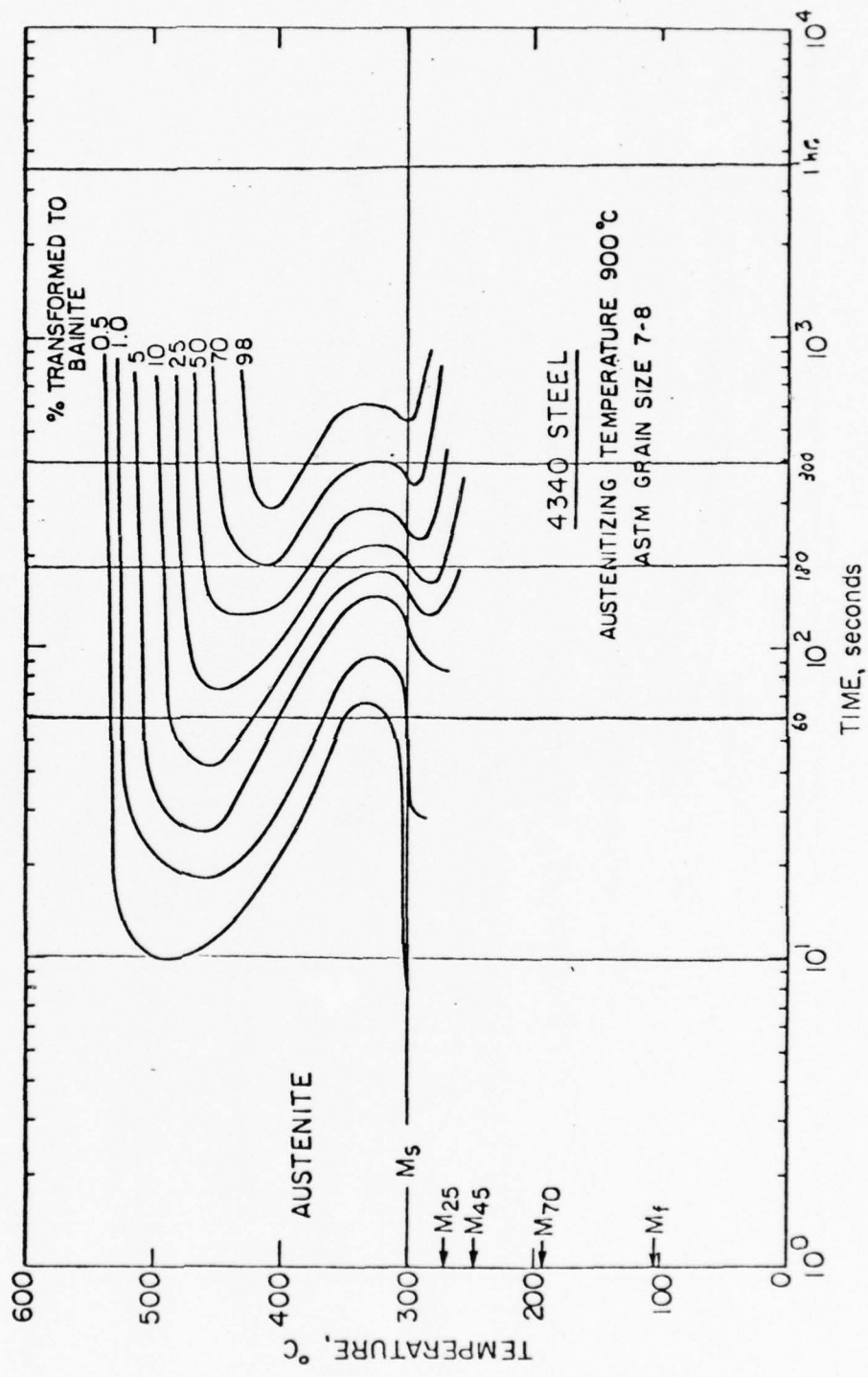

Figure 14. Isothermal transformation curve for alloy 4340 austenitized at 900°C

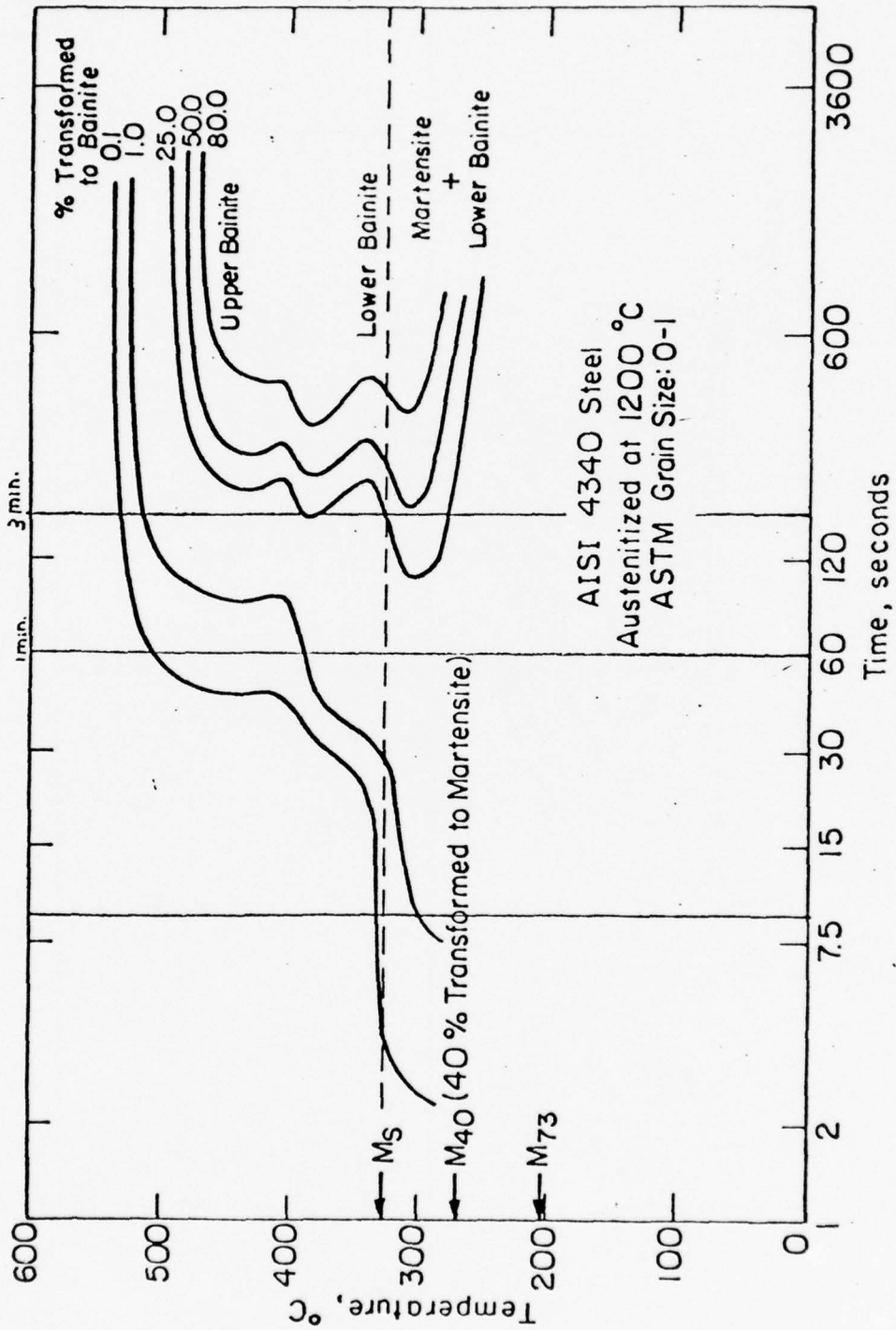

Figure 15. Isothermal transformation curve for alloy 4340 austenitized at 1200°C

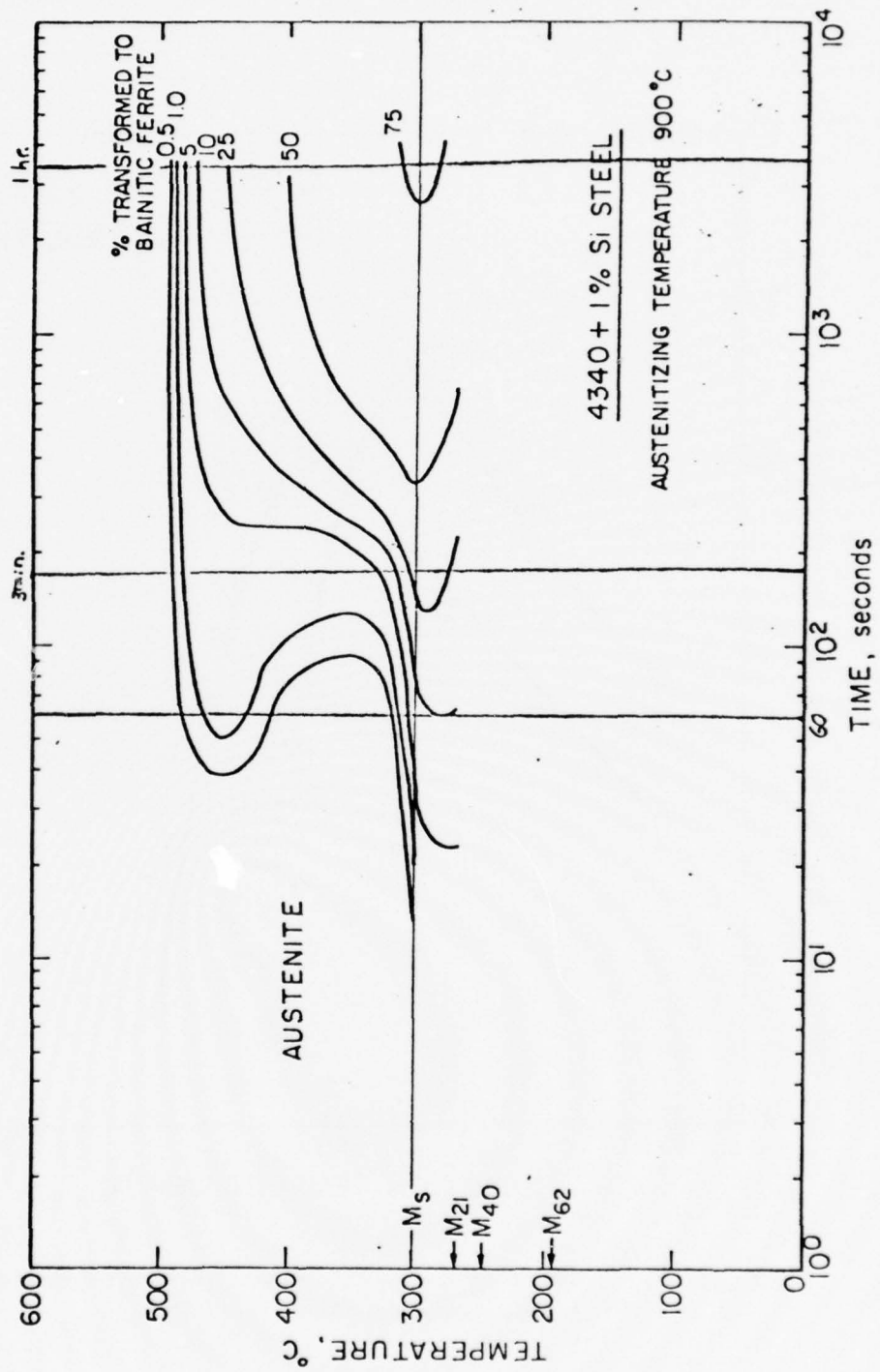

Figure 16. Isothermal transformation curve for alloy 4340 + 1% Si austenitized at 900°C

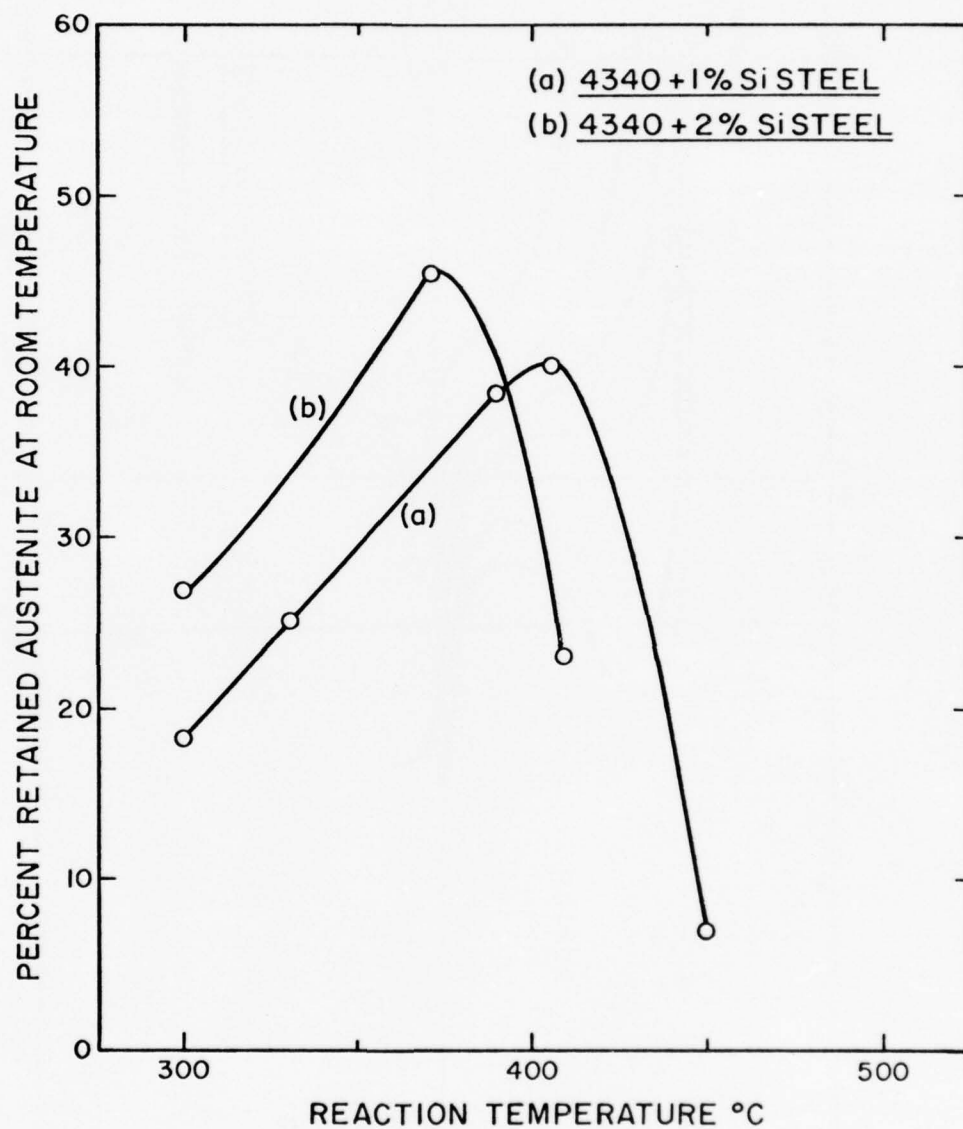
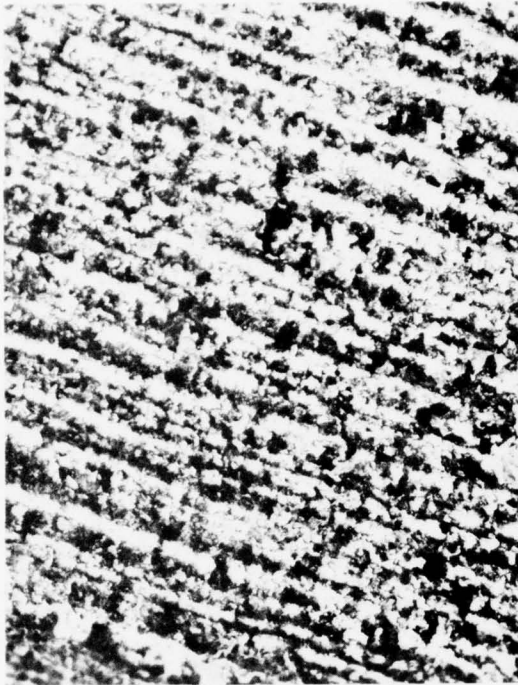
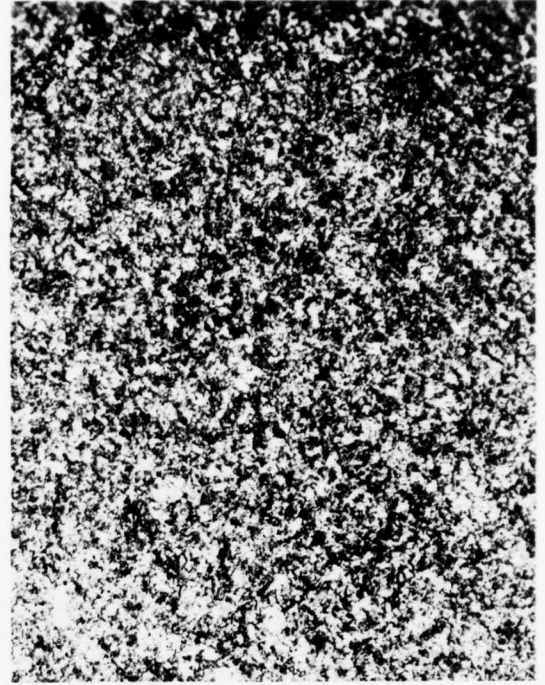

Figure 17. Reaction temperature vs. percent retained austenite for Si modified 4340 steel.



(a)

100X



(b)

100X



(c)

100X



(d)

1000X

Figure 18.

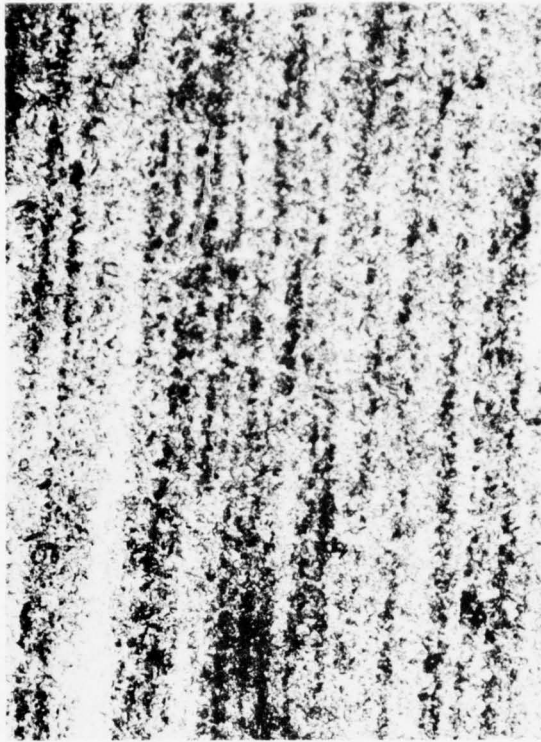

(a)

100X

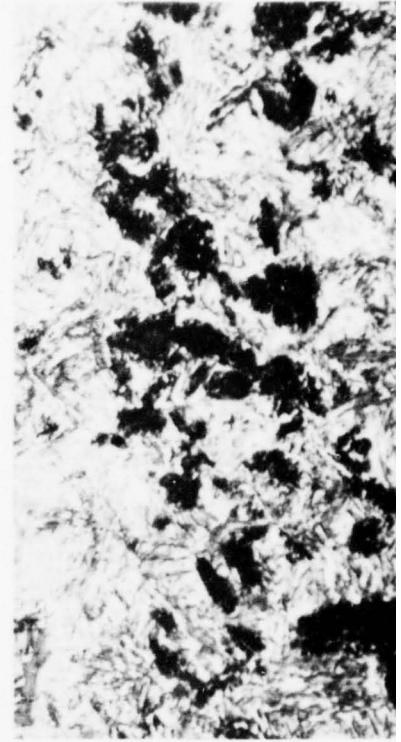

(b)



(c)

4000X

Figure 19.



500X



(a)

500X

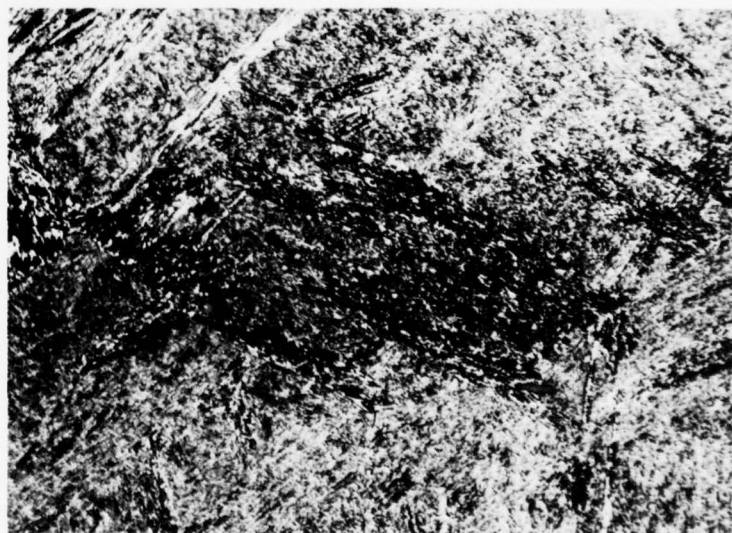

(b)

500X

Figure 20.

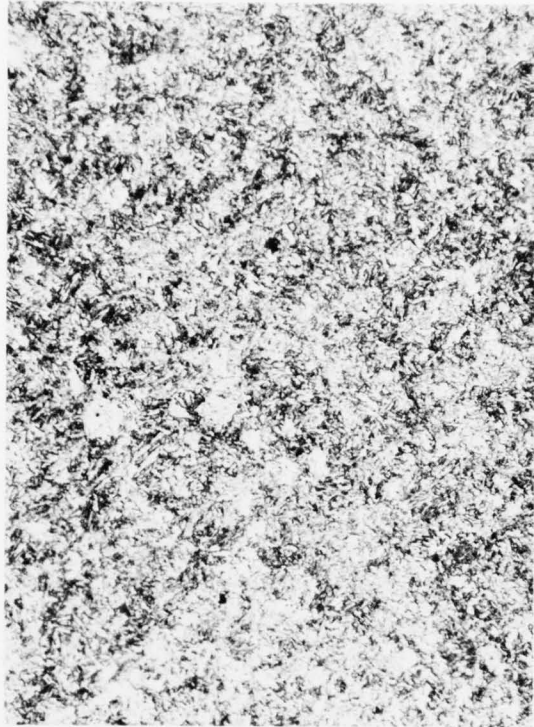

(a)

100X

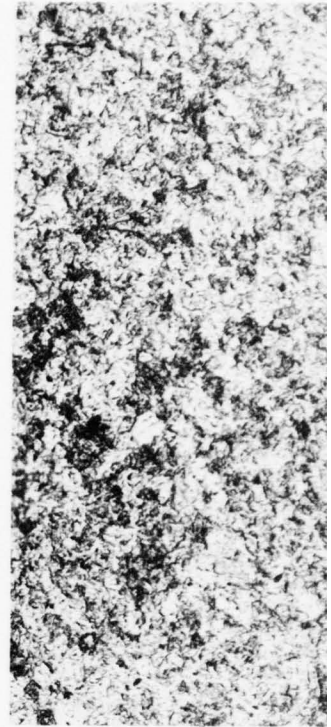

(b)



(c)

2000X



(d)

Figure 21.

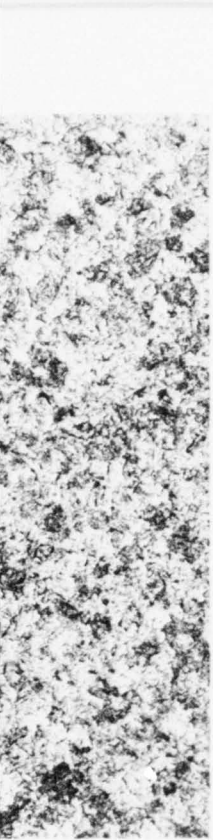

100X



100X



(a)

500X

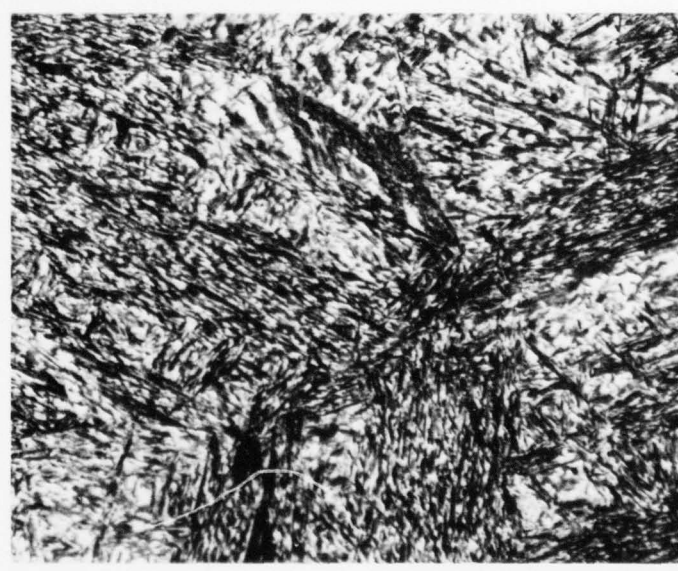

(b)

500X

Figure 22.



(a) 500X

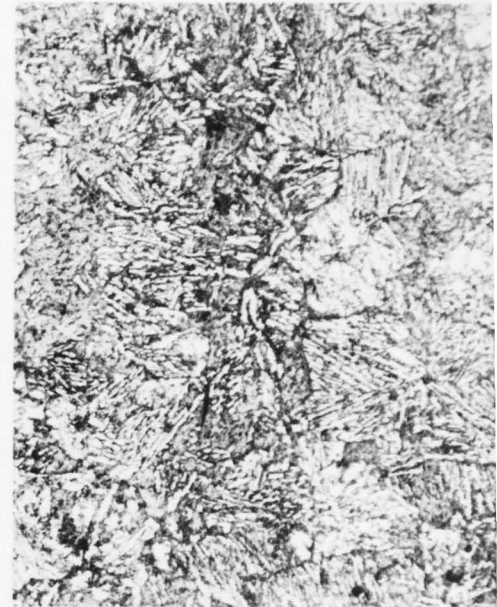

(b) 500X



(c) 500X



(d) 500X

Figure 23.



(a)
10,000



(b)
10,000X

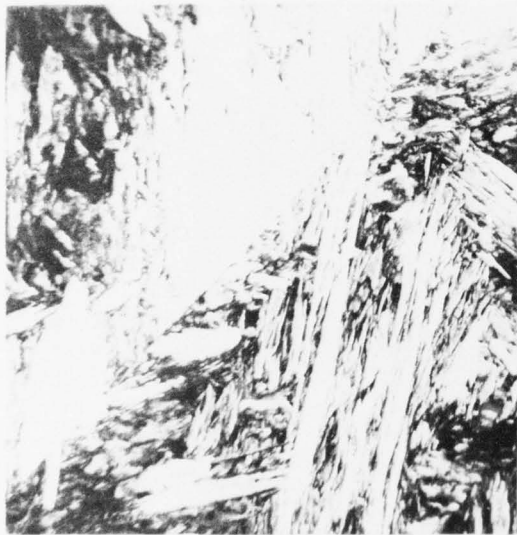

(c)
2500X



(d)
8500X



(e)
7500X

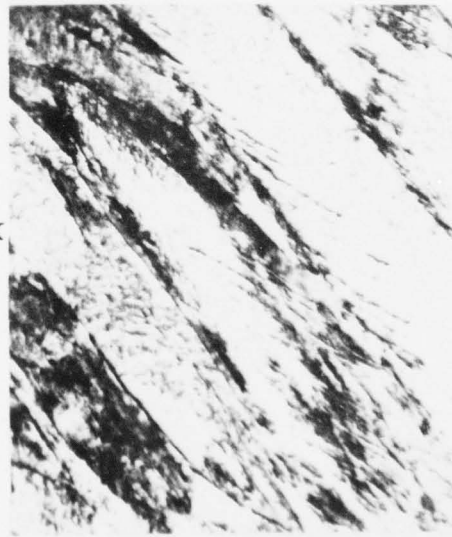

(f)
8,000X

Figure 24.



(a)
18,000X



(b)
18,000X



(c)
18,000X



(d)
30,000X

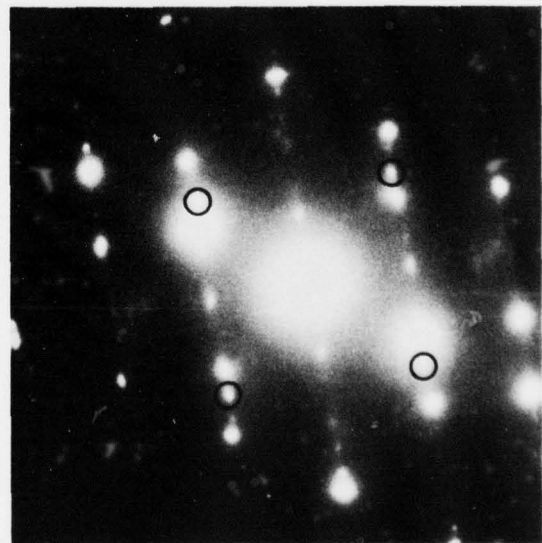

(e)

Figure 25.



(a)
10,000X



(b)
12,000X

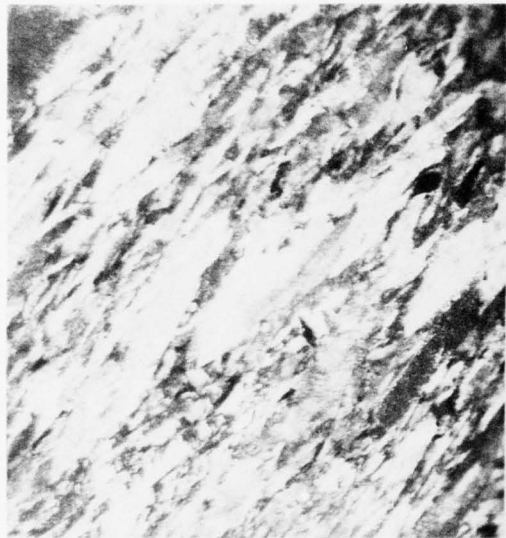

(c)
12,000X



(d)
12,000X

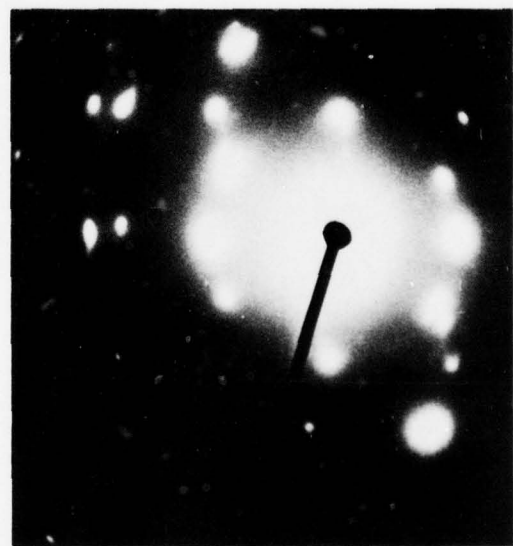

(e)

Figure 26.



(a)
6500X



(b)
14,000X

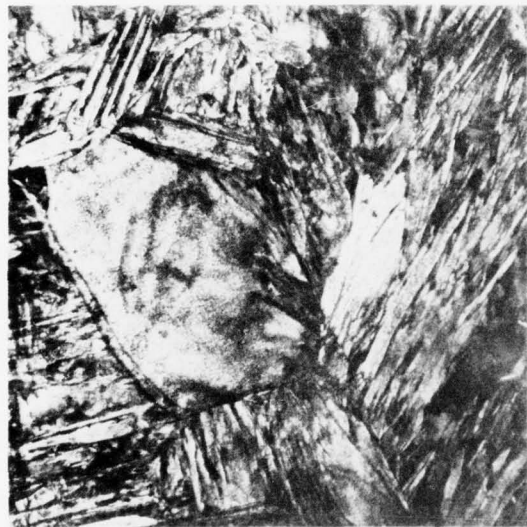

(c)
5500X



(d)

- ⊙ [100] Ferrite spot
- ▲ [111] Ferrite spot
- ▣ [110] Austenite spot

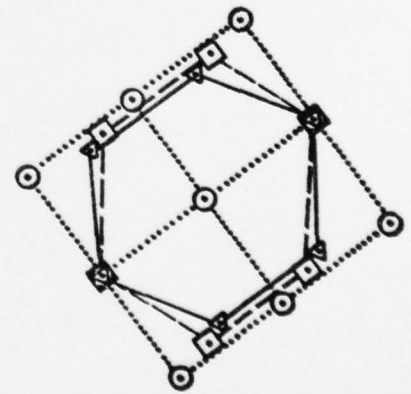

(e)

Figure 27



(a)

2500X

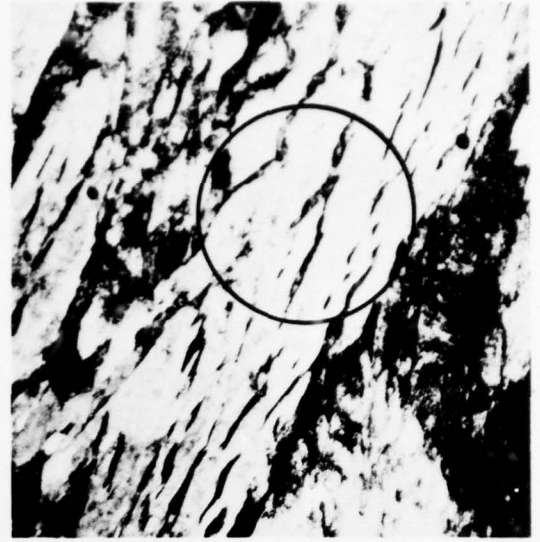

(b)

18,000X

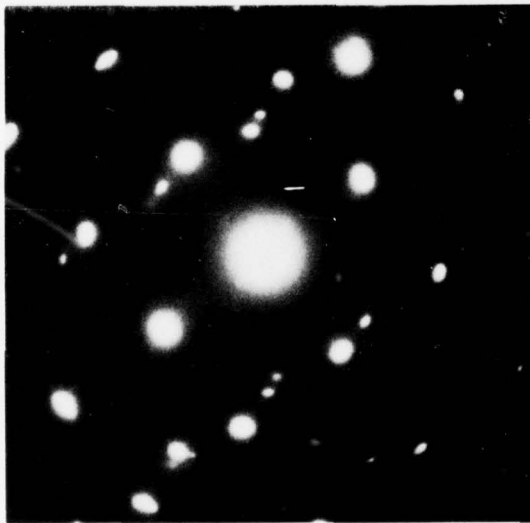

(c)

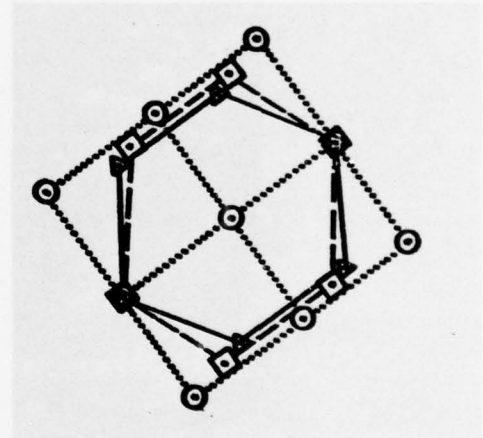

⊙ [100] Ferrite spot

▲ [111] Ferrite spot

□ [110] Austenite spot

(d)

Figure 28.

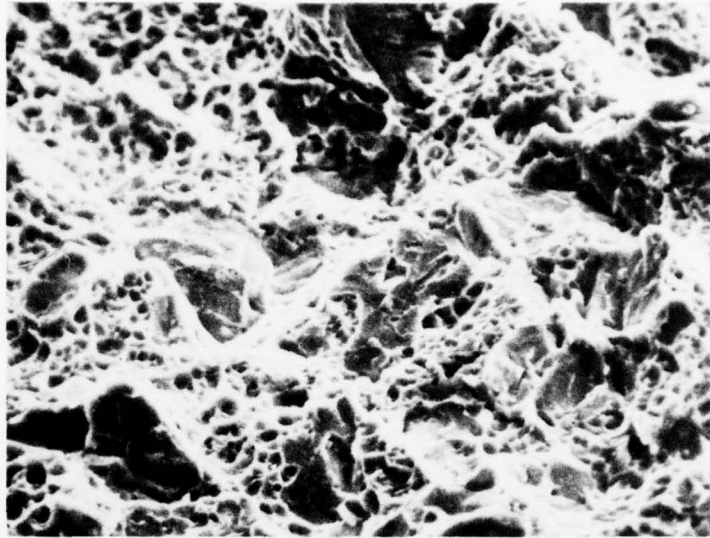

(a)
2000X

$R_c = 55$
 $K_{Ic} = 39$
ksi-in^{1/2}

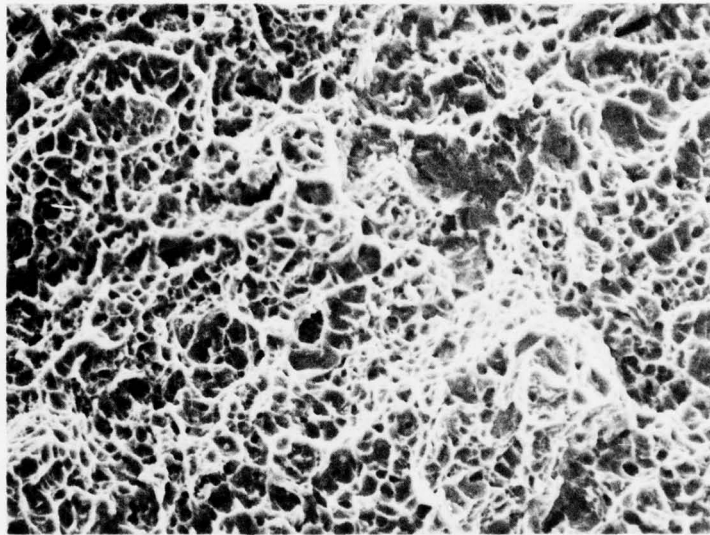

(b)
2000X

$R_c = 51$
 $K_{Ic} = 65$
ksi-in^{1/2}

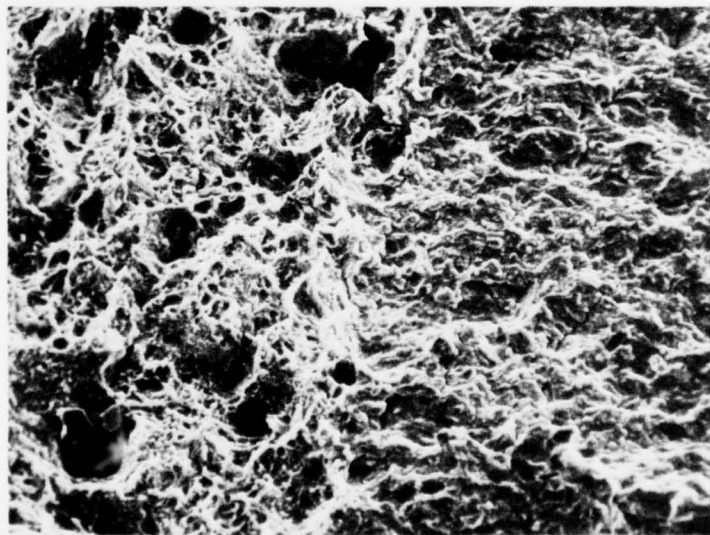

(c)
500X

$R_c = 44$
 $K_{Ic} = 103$
ksi-in^{1/2}

Figure 29.

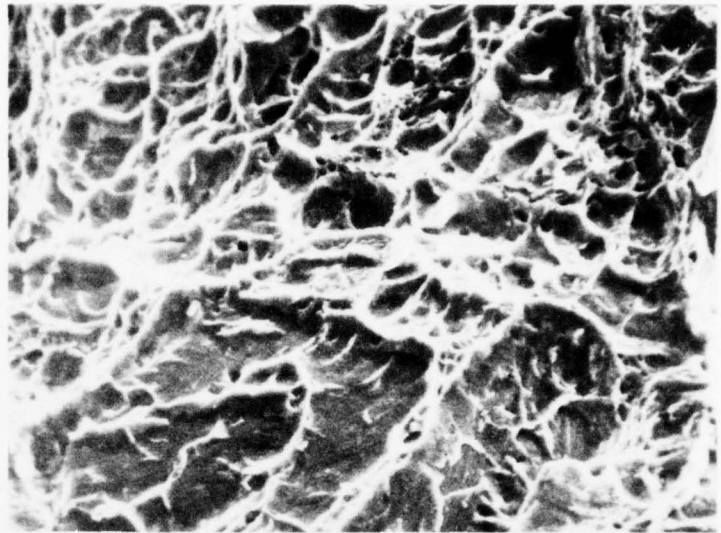

(a)
2000X
 $R_c = 52$
 $K_{Ic} = 85$
ksi-in^{1/2}

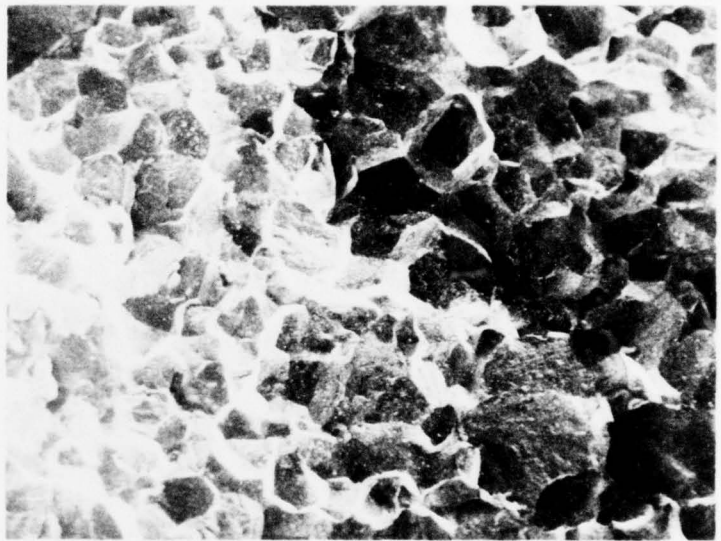

(b)
50X
 $R_c = 55$
 $K_{Ic} = 53$
ksi-in^{1/2}

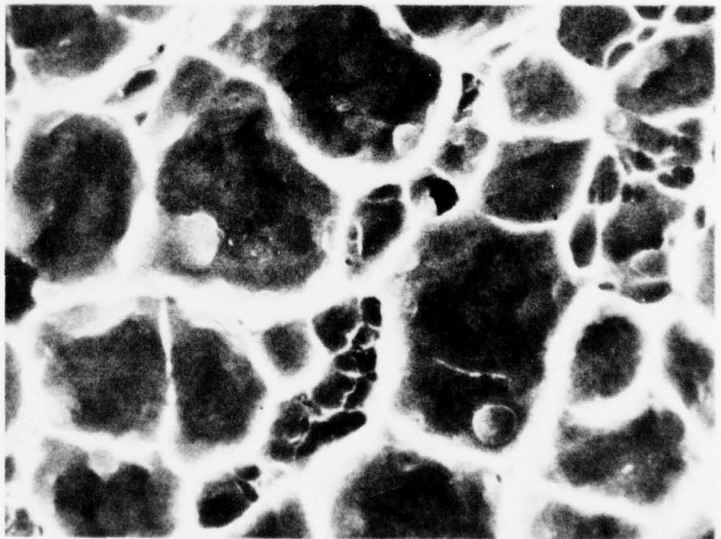

(c)
5000X

Figure 30.

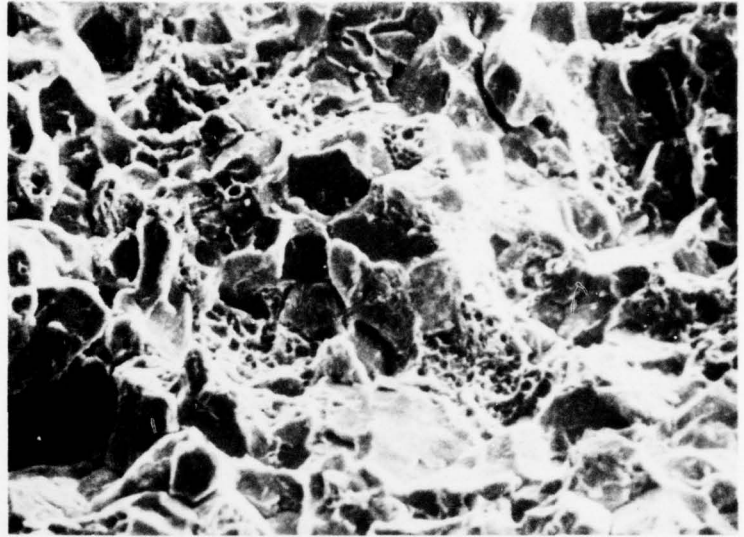

(a)

1000X

$R_c = 55$
 $K_{Ic} = 40$
ksi-in^{1/2}

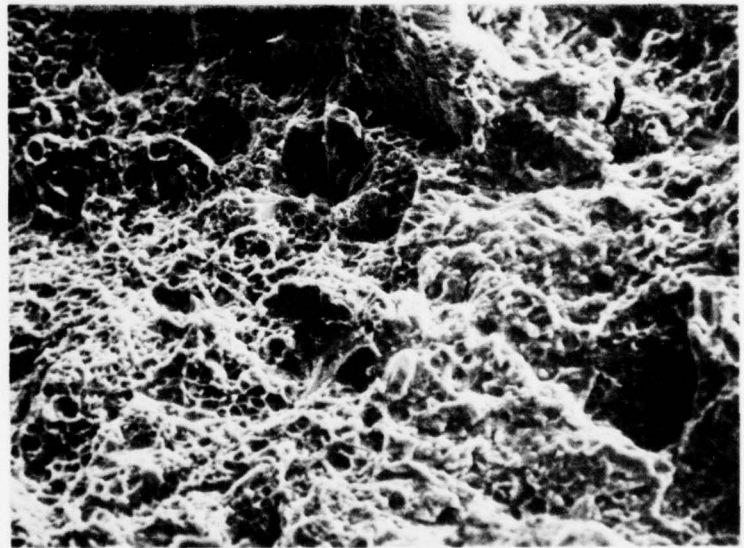

(b)

1000X

$R_c = 47$
 $K_{Ic} = 52$
ksi-in^{1/2}

Figure 31.

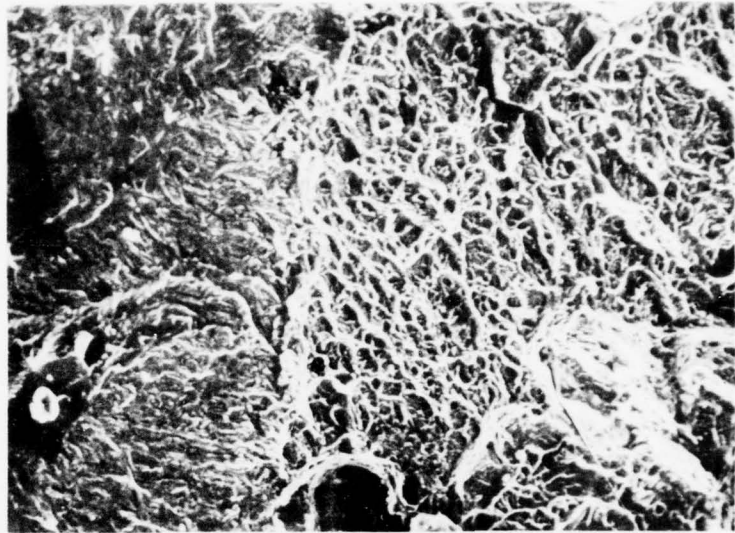

(a)
500
 R_c
 K_{Ic}
ksi.



(b)
100
 R_c
 K_{Ic}
ksi-

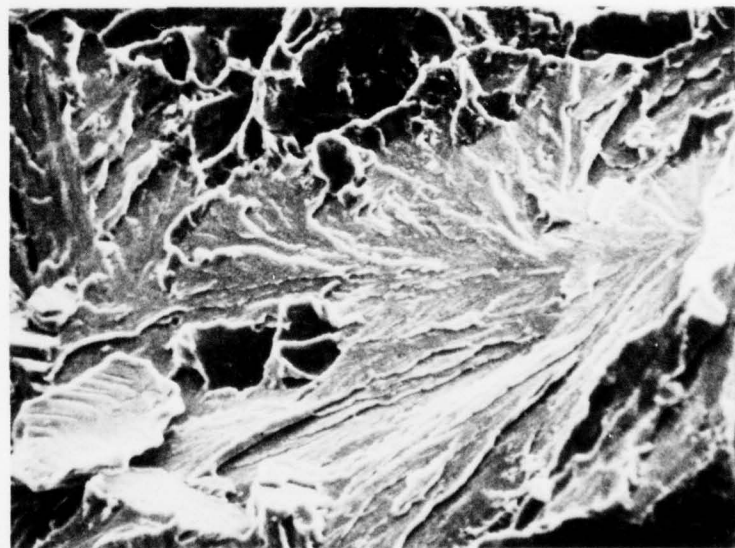

(c)
100
 R_c
 K_{Ic}
ksi.

Figure 32.

K
51
= 90
in 1/2

X
47
= 76
in 1/2

X
33
= 51
in 1/2

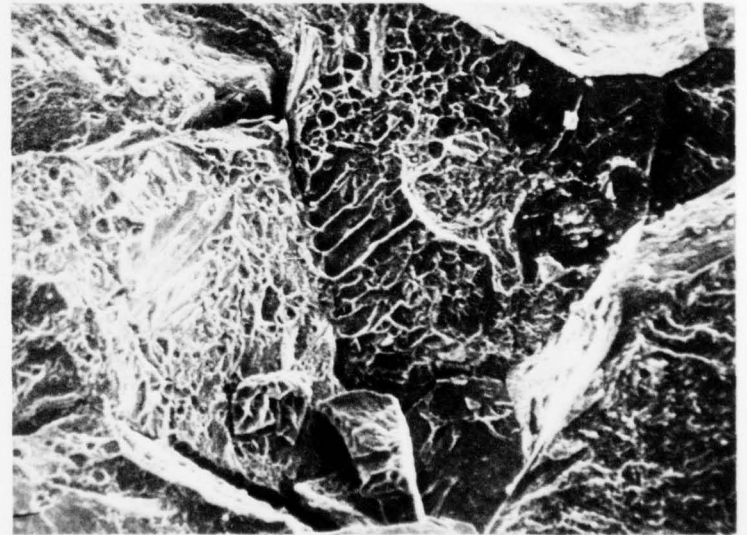
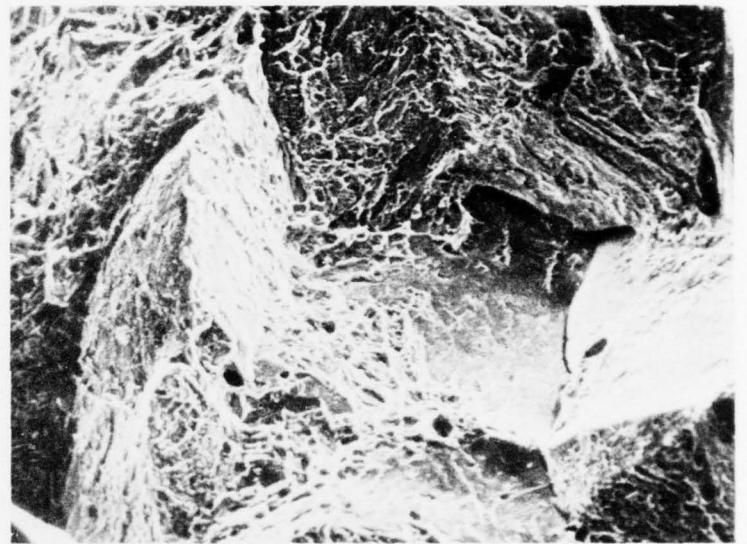
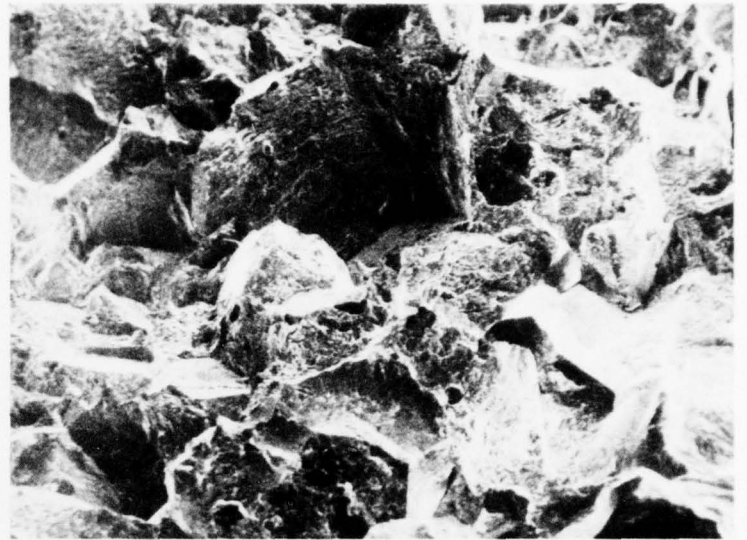

Figure 33.

(
F
F
k

(
5
R
K
k

(
5
F
F
k

0X
= 53
= 91
ksi-in^{1/2}

)
00X
= 51
= 86
ksi-in^{1/2}

)
00X
= 53
= 67
ksi-in^{1/2}

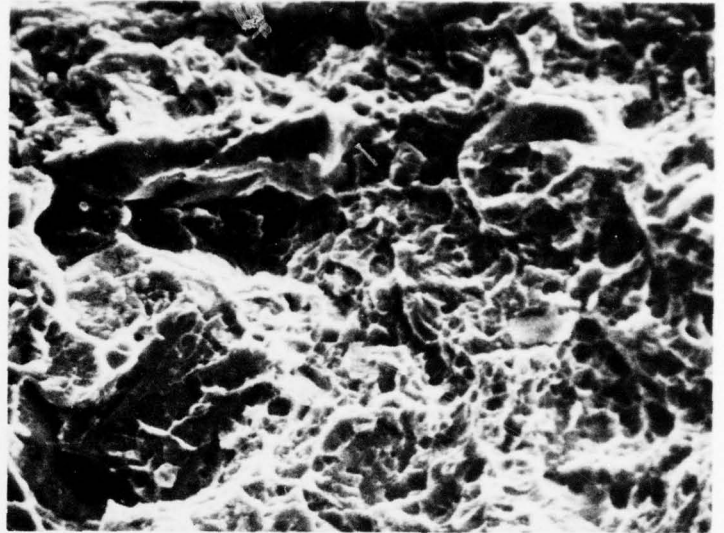

(a) 2000X

$R_c = 56$
 $K_{Ic} = 37$
ksi-in^{1/2}

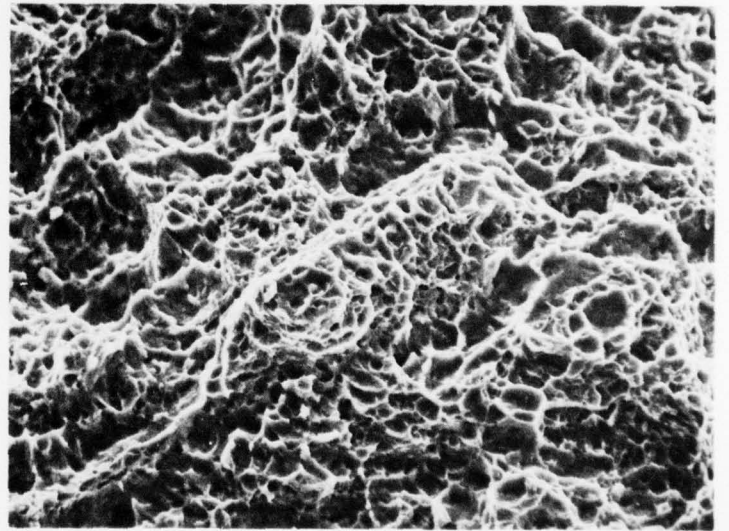

(b) 2000X

$R_c = 52$
 $K_{Ic} = 68$
ksi-in^{1/2}

Figure 34.

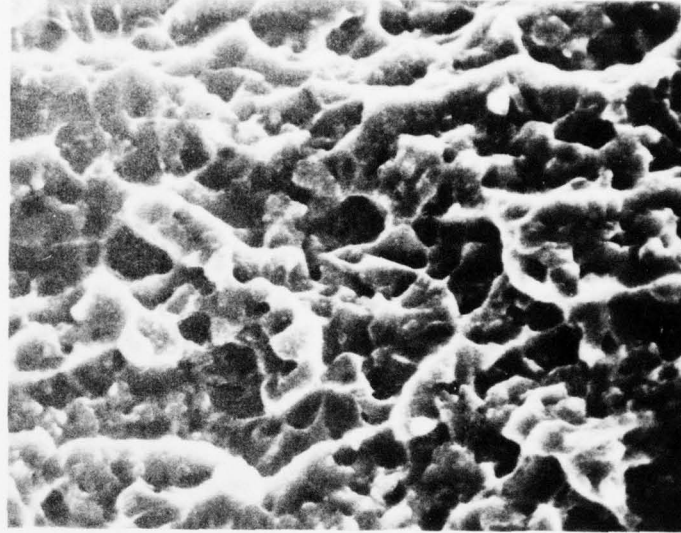

(a)

5000X

$R_c = 57$
 $K_{Ic} = 44$
ksi-in^{1/2}

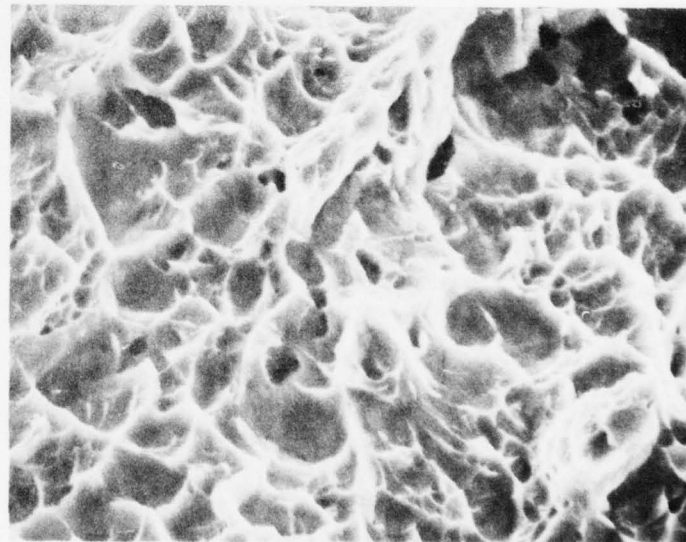

(b)

5000X

$R_c = 54$
 $K_{Ic} = 86$
ksi-in^{1/2}

Figure 35.

END

DATE

FILMED

6

—

7