

AD-A040 427

GRUMMAN AEROSPACE CORP BETHPAGE N Y RESEARCH DEPT
IMAGE ROTATION IN OPTICAL CORRELATORS THROUGH ROTATIONAL DEVICE--ETC(U)
JAN 77 R HEROLD, K LEIB

F/G 17/8

UNCLASSIFIED

RM-627

NL

| OF |
AD
A040427



END

DATE
FILMED
7-77

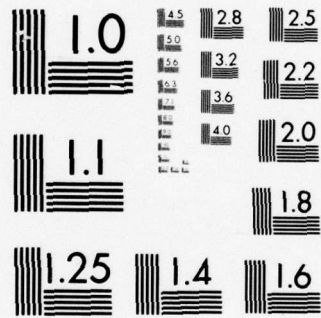

MICROCOPY RESOLUTION TEST CHART
NATIONAL BUREAU OF STANDARDS-1963-A

RM-627

IMAGE ROTATION IN OPTICAL
CORRELATORS THROUGH
ROTATIONAL DEVICES

January 1977

Unclassified

SECURITY CLASSIFICATION OF THIS PAGE (When Data Entered)

REPORT DOCUMENTATION PAGE		READ INSTRUCTIONS BEFORE COMPLETING FORM
1. REPORT NUMBER RM-627 ✓	2. GOVT ACCESSION NO.	3. RECIPIENT'S CATALOG NUMBER
4. TITLE (and Subtitle) Image Rotation in Optical Correlators Through Rotational Devices ✓		5. TYPE OF REPORT & PERIOD COVERED Memorandum
		6. PERFORMING ORG. REPORT NUMBER RM-627 ✓
7. AUTHOR(s) Ronald Herold Kenneth Leib		8. CONTRACT OR GRANT NUMBER(s) N/A
9. PERFORMING ORGANIZATION NAME AND ADDRESS Grumman Aerospace Corporation ✓		10. PROGRAM ELEMENT, PROJECT, TASK AREA & WORK UNIT NUMBERS N/A N/A
11. CONTROLLING OFFICE NAME AND ADDRESS N/A ✓		12. REPORT DATE January 1977 ✓
		13. NUMBER OF PAGES 2/24
14. MONITORING AGENCY NAME & ADDRESS (if different from Controlling Office) N/A ✓		15. SECURITY CLASS. (of this report) Unclassified
		15a. DECLASSIFICATION/DOWNGRADING SCHEDULE
16. DISTRIBUTION STATEMENT (of this Report) Approve for Public release, distribution unlimited ✓		
17. DISTRIBUTION STATEMENT (of the abstract entered in Block 20, if different from Report) N/A		
18. SUPPLEMENTARY NOTES NA ✓		
19. KEY WORDS (Continue on reverse side if necessary and identify by block number)		
20. ABSTRACT (Continue on reverse side if necessary and identify by block number) An analysis is conducted of parallel faced, image rotation prisms to determine their offset and other beam phase change effects under perfect, and less than perfect, constructions. The results show that offset by a "perfect" prism generally does not affect optical correlator performance but wedges greater than 0.2 arc second seriously affect correlator performance. ←		

14

12

6 9 Memorandum ~~rept.~~

IMAGE ROTATION IN OPTICAL CORRELATORS
THROUGH ROTATIONAL DEVICES,

by

10

Ronald Herold

and

Kenneth Leib

System Sciences Section

12 28 p.

11

Jan 1977

DDC
RECEIVED
JUN 10 1977
RESERVED

A

Approved by: Charles E. Mack, Jr.
Charles E. Mack, Jr.
Director of Research

ADMISSION 201	
RTIS	Write Section <input checked="" type="checkbox"/>
BDC	Buff Section <input type="checkbox"/>
UNANNOUNCED	<input type="checkbox"/>
JUSTIFICATION	<input type="checkbox"/>
BY	
DISTRIBUTION AVAILABILITY CODES	
REL. L. A. L. U. S. F. W. A. S. E.	

A

DISTRIBUTION STATEMENT A
Approved for public release;
Distribution Unlimited

102-115

B

ABSTRACT

An analysis is conducted of parallel faced, image rotation prisms to determine their offset and other beam phase change effects under perfect, and less than perfect, constructions. The results show that offset by a "perfect" prism generally does not affect optical correlator performance but wedges greater than 0.2 arc second seriously affect correlator performance.

TABLE OF CONTENTS

<u>Section</u>		<u>Page</u>
1	Introduction	1
2	Description	3
	Imperfections	7
	Misalignment	7
	Device Anomalies	9
	Phase Shift	12
	Polarization Effects	15
3	Conclusions	21
4	References	22

LIST OF ILLUSTRATIONS

<u>Figure</u>		<u>Page</u>
1	Basic Configuration	4
2	Representative Image Rotation Devices	6
3	Tilted K-Mirror System	10
4	Positional Sensitivity of High Pass Matched Filter	13
5	Portion of Third Order Matched Filter of M-60 Tank	14
6	Polarized Paths in Image Rotators	17
7	Dependence of Reflection Coefficient Upon Angle of Incidence and State of Polarization	19

1. INTRODUCTION

A significant amount of work has been done to understand and develop optical matched filter correlators (e.g., Ref. 1). One of the principal limitations of such correlators has been the need for an adequate storage without analog-to-digital conversions or other forms of hybridization techniques. Some progress was made in an all optical system by using multiple holographic storage techniques. These techniques are outlined in Ref. 2; portions of the investigation were verified independently by others as reported in Ref. 3. The multiple holographic storage techniques involve the preparation of many matched filters in a matrix array, sometimes obtaining several filters in a single position by overlapping. As many as 100 matched filters have been fabricated in a 10 x 10 array and predictions for as many as five or six hundred seem well founded (Ref. 2). The ability to prepare storage positions for a particular target thus seems to be achievable although time consuming. The real problem is the number of storage positions required for any one given target if such factors as orientation, scale, obliquity, and resolution are to be considered. Some signal processing techniques suggest that more than one order of matched filter be used to process the unknown signal. The discouraging aspect of this is that each additional factor generally multiplies the required number of filters. The ability to record upwards of six hundred images then becomes less impressive, especially when multiple target recognition capability is important.

In summary, matched filter correlators appear to be technologically possible and warrant consideration for some applications. If storage problems can be solved, then the correlator becomes even more attractive.

This memorandum provides an analysis of the problems of one approach to remedy, partially, the storage problem (the use of image rotation devices). In these devices, the image of the object rotates so that the entire scene is presented to the appropriate matched filter(s) at different rotational views for processing. Many prisms and mirror systems have been in use for a long period of time in different systems with success. However, the authors do not know of any successfully being used in coherent optical matched filter systems. It is to some of the problems of image rotation that the investigation is addressed.

2. DESCRIPTION

The basic configuration of the correlator is shown in Fig. 1 with the image rotation device installed. A collimated laser beam illuminates the object film to be analyzed. The latter is shown as a 35 mm film strip, but may be any of the standard sizes of reconnaissance film. The spatially modulated laser beam is directed through some image rotation device. Whether rotated or not, the image is presented to the transform lens which takes the Fourier transform of the modulated beam and displays it at the matched filter. If the target for which the filter is made is present at the input, its presence is made known by virtue of the inverse transform lens thus resulting in an autocorrelation peak in the correlation plane.

The object film is located the equivalent of one focal length F' behind the transform lens, accounting being made for any path length extensions due to the image rotation device. While the correlation plane to inverse transform lens (not shown) spacing is important, the spacing of the combination to the matched filter plane is not critical. The matched filter plane is located one focal length from the transform lens so that $F' = F$. The inset of Fig. 1b shows in detail the axes used in this analysis.

When a matched filter is fabricated, the reference beam is directed along the axis indicated. The angle between the reference and signal axes is typically in the interval 10-30 degrees. If F is the transform lens focal length, the spatial frequency spectral sensitivity, ν' , is

$$\nu' = (\lambda F)^{-1} \text{ cycles/mm/mm} \quad (1)$$

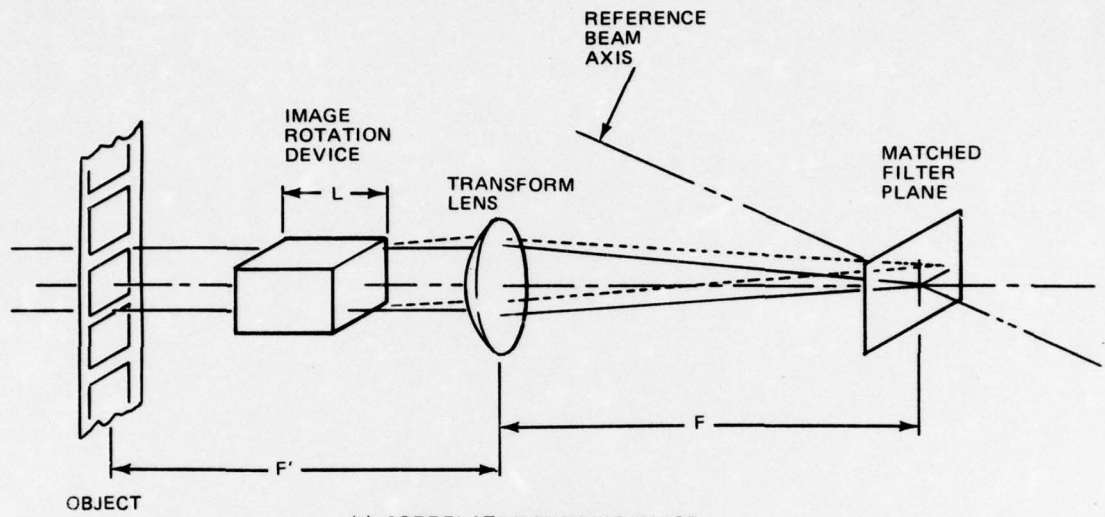

(a) CORRELATOR SHOWING IMAGE ROTATION DEVICE

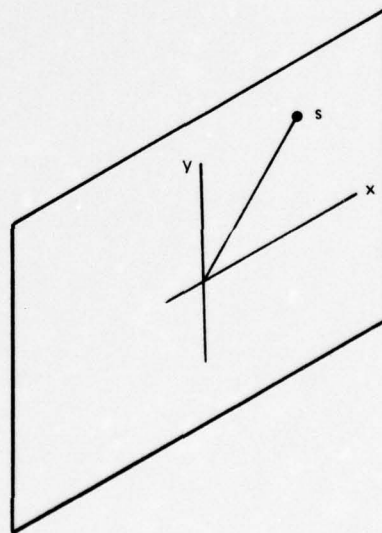

(b) DETAIL OF AXES

Fig. 1 Basic Configuration

where the focal length and wavelength λ are given in millimeters. For example, if the correlator uses a helium-neon laser, the sensitivity of a system using a 360 mm transform lens becomes 4.39 cycles/mm/mm.

There are a number of opto-mechanical image rotation devices and these can be grouped according to whether they are normal or oblique incidence prisms or mirror systems. A few of the representative types are shown in Fig. 2.

The image rotation devices, particularly the oblique incidence prisms, often depend upon total internal reflection for which the incident angles in the medium are

$$\sin^{-1} \theta_i = (n_{\text{prism}})^{-1} \quad (2)$$

By ray tracing it can be seen that all of the devices shown invert an image and provide a rotation to the image which is at twice the device rotation rate.

The analysis below is confined to the normal incidence prisms as well as the K-mirror system. It might be applicable to all parallel face prisms but there is no proof that there might be a prism for which it is not true.

The presence of the image rotation device, whether a prism or mirror combination, presents a number of potential problems which require an assessment. These are:

- Presence of voids, refractive imperfections, and similar anomalies in the prism glass (common to all optical elements)
- Tilting of the device axis off the system optical axis in otherwise perfect systems (alignment)

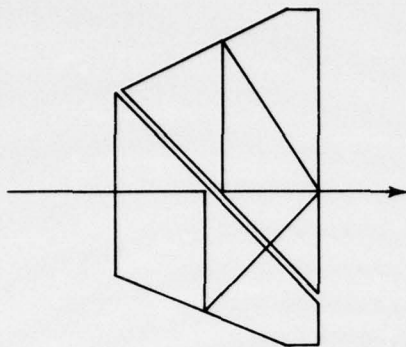

PECHAN

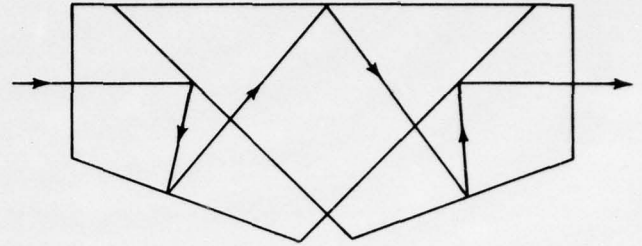

THREE-ELEMENT PRISMS

NORMAL INCIDENCE PRISMS

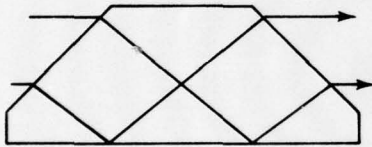

HARTING-DOVE

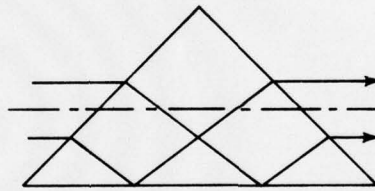

45-90

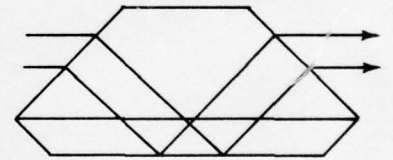

AMICI

OBLIQUE INCIDENCE PRISMS

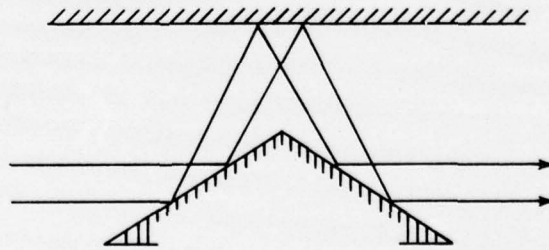

K-MIRROR SYSTEM

Fig. 2 Representative Image Rotation Devices

- Lack of parallelism in prism faces or asymmetrical placement of mirrors as the case may be (wedge angle error)
- Question of phase shift across an extended object
- Influence of polarization upon transmission of the beam through the image rotating system

It would be surprising if any of the anomalous conditions listed above had anything but an adverse effect upon optical correlator performance. Thus, one of the purposes of this analysis is to continue to quantify the various aspects of the Optical Matched Filter Image Correlator (OMFIC) technology. This is in addition, of course, to determining just what might be required in the precision of a parallel faced, image rotating prism.

IMPERFECTIONS

The imperfections listed, as well as similar ones which are often encountered in optical systems generally, are not unique to the image rotating device and are therefore not included in this analysis.

MISALIGNMENT

Misalignment refers to the lack of congruence between the correlator axis and the rotation device axis. In this case, it is assumed that the faces of the prism are parallel, and in both analyses (mirror and prisms), all internal structural angles are executed perfectly. Misalignment errors are the most readily correctable through autocollimation techniques. A parallel-face prism system

that is otherwise perfect will impart a constant offset, $s = (x^2 + y^2)^{\frac{1}{2}}$, to the image when the prism is tilted about its center and in the plane containing the correlator axis. This offset is

$$s = \left(\frac{L}{n_p} \right) \sin \theta_i \text{ mm} \quad (3)$$

where θ_i is the angle of incidence for a prism fabricated of glass whose index of refraction is n_p . L is the axial thickness of the prism assembly in mm.

The offset is equivalent to a translation of the original object by an amount (s_x, s_y) to a new location in the input plane. The Fourier transform of this shifted input distribution will be given by the product of the original transform function and a delta function. The autocorrelation peak (if present) and background will track together with variations in the offset although in the opposite sense because of the sign inversions of the transformation.

Since the offset depends directly upon L , and the misalignment is usually small so that $\sin \theta_i \approx 0$, the offset does not increase significantly being only microns per centimeter of (over-all) prism length.

If the parallel face prism assembly is now given a tilt that is also askew of the correlator axis, an offset will also be imparted to the beam by an amount

$$s = L \left[\frac{n_p^2 (1 + \gamma^2)^2}{n_p^2 (1 + \gamma^2) - \alpha^2} \right]^{\frac{1}{2}} \text{ mm} \quad (4)$$

Again, n_p is the prism refractive index, and γ and α are the angles the prism axis makes with the correlator axis and an orthogonal reference axis, respectively. Because the angles are small,

the small angle approximations were used. Also, since the angles are small in practice, s is again of the order of microns offset per centimeter of prism length.

There is an equivalent situation in the K-mirror system to a tilt, β , of the system in the plane containing the mirror system-correlator axes. This gives rise to two problems: does the transmitted image have an offset, and, what is the limit of its tilt? The schematic for this situation is shown in Fig. 3 where the terms are also defined. If we prescribe the geometrical parameters of the K-mirror system as d , α , and l we can determine the maximum value for β . Therefore,

$$\beta_{\max} = \tan^{-1} \left(\frac{2d \tan \alpha + l}{l \tan \alpha} \right) \quad (5)$$

is the maximum tilt angle but also within this limiting angle, there is no offset given to the incoming image.

DEVICE ANOMALIES

It was stated earlier that one of the problems that caused great concern was the lack of device perfection. The intent of this analysis is not to explore the entire matrix of combinations of potential problems but to examine the principal ones such as the existence of a wedge in the prism, or the angular deviation of a single mirror in the K-mirror image rotation system. These two problems are considered.

Consider first the Pechan assembly as an example of the parallel-faced prisms. It was found earlier that a tilt of the axis for a perfect assembly yields a uniform phase retardation and hence the beam remains parallel to the optical axis. Now suppose that a beam is incident upon the face of a prism whose wedge angle is η and

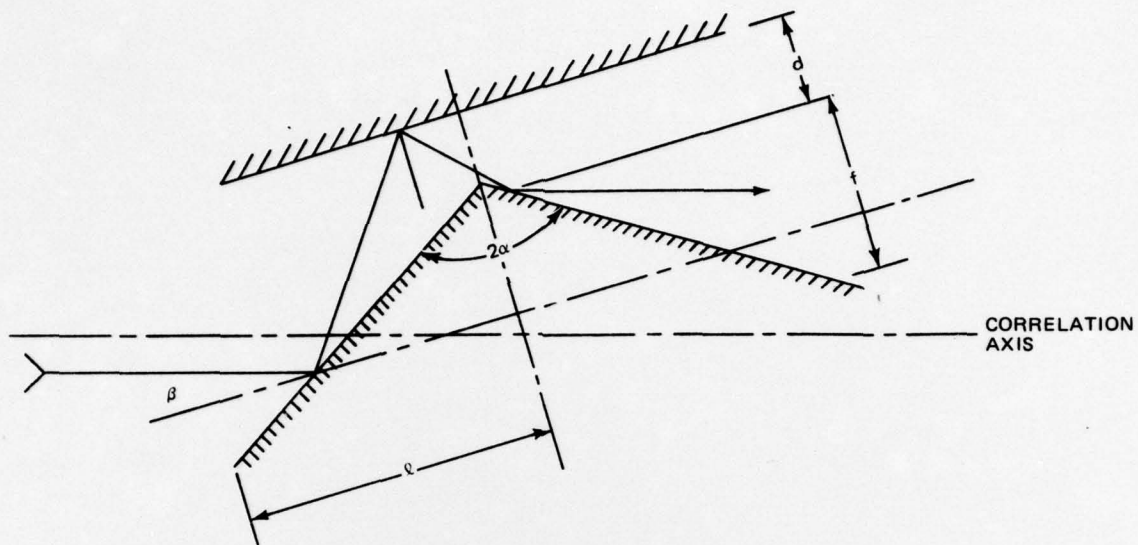

- β ANGLE OF K-MIRROR SYSTEM TILT
- α HALF ANGLE OF K-MIRROR APEX
- l HALF OF BASELENGTH OF CYLINDRICAL MIRROR
- f ALTITUDE OF MIRROR
- d DISTANCE BETWEEN APEX AND PLANE MIRROR

Fig. 3 Tilted K-Mirror System

suppose further, that all other surfaces are in accord with the theoretical requirement. Then a ray trace through the prism would yield

$$\sin \epsilon_{out} = n_g \left[\sin \epsilon_{in} (1 - \sin^2 \eta)^{\frac{1}{2}} + (1 + \sin^2 \epsilon_{in})^{\frac{1}{2}} \sin \eta \right] \quad (6)$$

where $\epsilon_{in,out}$ are the incident, output deviation angles measured from the optical axis. Clearly, upon normal incidence this becomes simply

$$\sin \epsilon_{out} = n_g \sin \eta \quad (7)$$

Since all angles are generally small, the output angular deviation will be about 50 percent greater than the wedge angle since n_g is 1.52. For example, a 10 second wedge angle yields a 15.2 second deviation. The positional offset in the transform plane, Δ , is proportional to the focal length F and upon rotation, the transform rotates in a circle of radius

$$\Delta = F \sin^{-1} \left[n_g \sin \eta \right] \quad (8)$$

The same wedge of 10 seconds now produces an offset of 1.52 mm in a correlator whose transform lens has a focal length of 360 mm. Since the spectral sensitivity of such a lens is 4.39 cycles/mm/mm, clearly the wedge is excessive. Working backwards, if something less than one cycle/mm deviation is assumed as acceptable, then the wedge angle of the prism must be kept down to two arc seconds or less. Worse yet is the case in which the input angle, ϵ_{in} , is off by 10 seconds. For this angle, the same wedge would yield an output deviation greater than 15 arc minutes and produce an entirely unacceptable situation.

In summary, if a 77 percent spectrum overlap were acceptable the Pechan prism assembly must be aligned within a second of being parallel to the optical axis and have a wedge angle of this same value. However, since matched filter spectral sensitivity is F^{-1} dependent, and the offset of the transform at the matched filter is F dependent, the requirement on prism wedge angle is determined by the translational misregistration at the filter.

From the previous investigation[†] it was found that the positional sensitivity of the matched filter to movement along an axis

[†] Reference 2, Appendix C.

perpendicular to the major axis of the tank was 50 micrometers. The sensitivity is illustrated in Fig. 4 where the sensitivity along the other two orthogonal axes is also shown. Note that the most stringent sensitivity is along the same axis which contains the third order lobe where the matched filter was optimized. A portion of the matched filter is shown in Fig. 5 with the zero to third order lobes oriented along what is defined as the x-axis.

The 50 μm sensitivity is defined as the amount of lateral translation which will produce a reduction of 50 percent (-3 db) in the autocorrelation signal. We could use this as a criterion for alignment or offset and if this criterion were used, the prisms parallelism requirement becomes much more severe being about 0.33 arc second. As pointed out, this requirement on the prism does not depend upon the transform lens focal length. The 50 μm offset is equivalent to 0.22 cycles/mm and thus, implies a 95 percent spectrum overlap requirement for no more than a 3 db decrease in autocorrelation peak.

PHASE SHIFT

In this analysis the offset as a device anomaly was presented in the previous section. In truth, the offset is the result of a phase change in the propagating beam which results in a redirection of the beam. The present section gives a reassessment of the phase shift but in terms of the spatial distribution across the image.

Any prism which is less than totally parallel will obviously provide unequal path lengths for points across the image that enter the prism at different coordinates. This inequality means that there will be a spatial distribution of phase shift in the image, which upon rotation of the prism, will mean a spatial phase modulation as a function of time.

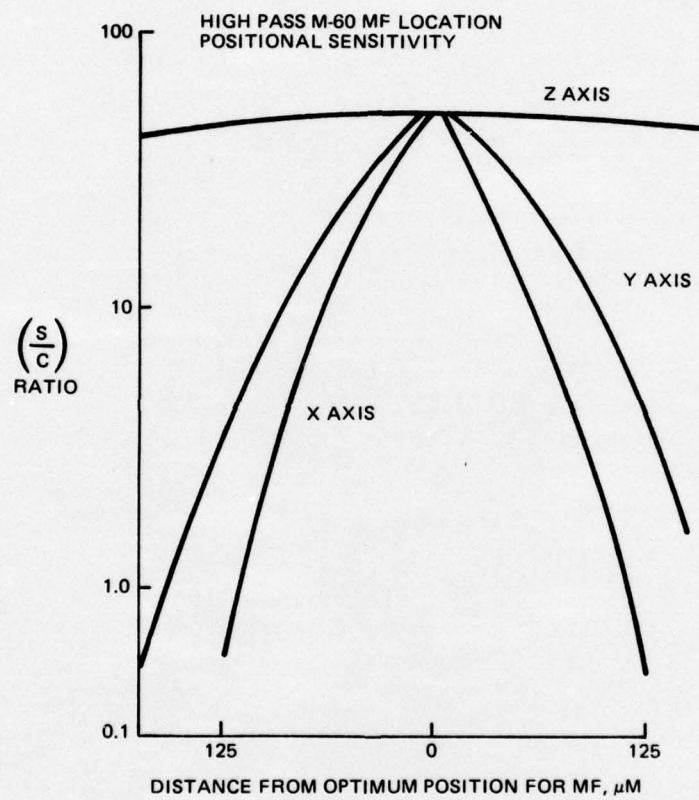

Fig. 4 Positional Sensitivity of High Pass Matched Filter

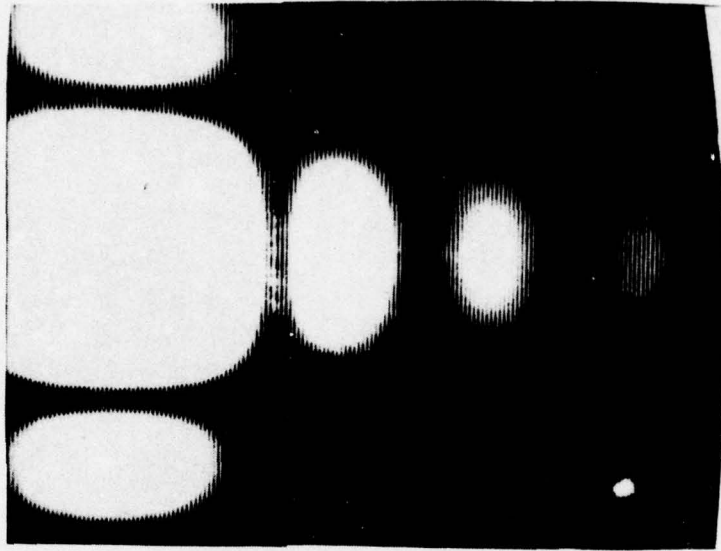

Fig. 5 Portion of Third Order Matched Filter of M-60 Tank

The phase shift along any path will depend, in general, upon the index of refraction of the prism as well as the path length through the prism. If we assume that the prism, though wedged in one dimension is rectangular in the other two dimensions, then the path will depend upon the rotational angle, Δ , as well as the radial distance, r , in the image plane. Thus

$$\begin{aligned} \delta\phi(r,\Delta) &= \frac{2\pi}{\lambda} (\Delta n)(\Delta h) \\ &= \frac{2\pi}{\lambda} (n_p - 1)h(r,\Delta) \end{aligned} \tag{9}$$

which finally becomes for the phase shift as a function of image point location, and time,

$$\delta\phi(r,t) = \frac{2\pi}{\lambda} \left\{ 2H_0 + (n_p - 1) [R_0 - r \cos \omega t] \tan \eta \right\} \quad (10)$$

where H_0 is the maximum axial path length difference for a given wedge measured from the prism axis and at a radius R_0 , η is the wedge angle, λ is the wavelength, and $f = \omega/2\pi$ is the frequency of prism rotation.

In a 35 mm film format, for example, $12 \text{ mm} \lesssim R_0 \lesssim 22 \text{ mm}$ while for a wedge angle of 10 arc seconds the corresponding value of H_0 is $1.1 \mu\text{m}$. At 6328 Angstroms wavelength, the maximum phase modulation at the edge of the frame diagonal becomes

$$\delta\phi = (26.66 - 5.47 \cos \omega t) \text{ radians} \quad (11)$$

POLARIZATION EFFECTS

In a correlator, the configuration is often such that a reference beam channel is included so that the matched filter can be fabricated in situ. In addition to being equal in path length to the signal channel, the reference channel must have the same linear polarization state as the signal channel in order to generate the interferometric matched filter. This means that a common light source is usually a linearly polarized laser even though the correlation measurement itself is independent of the source state of polarization.[†] Thus, it can be anticipated that in some situations an optical correlator would have a polarized laser source and when it does, it may influence the intensity distribution of the test image when image rotation devices are employed.

[†] Polarization effects in correlation measurements are present in a negligible amount. However, other more significant effects can arise in correlation measurements (see Ref. 4).

Consider the two schematic diagrams in Figs. 6(a) and 6(b) for the Pechan and K-mirror systems. Beam rays of two orthogonal polarizations are illustrated for an equivalent or equal optical path. The incident angles for the reflections for axial incidence in a Pechan prism[†] are $22\frac{1}{2}$, 45, and 90 degrees for beams of either polarization state. The output for each of the polarization states can be determined from the reflection coefficient at each surface and the input intensity. The difference, if any, would be determined by the effect each polarization state has and would be given by

$$\frac{I_{0\perp} - I_{0\parallel}}{I_{\text{input}}} = (r_1^2 r_2^2)_{\perp} - (r_1^2 r_2^2)_{\parallel} \quad (12)$$

where for the K-mirror system there are two identical reflection angles and a single different one. A similar relationship exists for the Pechan prism

$$\Delta I = (r_1^3 r_2^2)_{\perp} - (r_1^3 r_2^2)_{\parallel} \quad (13)$$

since there are five reflections.

Each of the reflections can be determined from the generalized Fresnel equations, one form of which is given by Simon (Ref. 6)

$$r_{\perp} = \frac{a^2 + b^2 - 2a \cos \theta_i + \cos^2 \theta_i}{a^2 + b^2 + 2a \cos \theta_i + \cos^2 \theta_i} \quad (14)$$

$$r_{\parallel} = \frac{a^2 + b^2 - 2a \sin \theta_i \tan \theta_i + \sin^2 \theta_i \tan^2 \theta_i}{a^2 + b^2 + 2a \sin \theta_i \tan \theta_i + \sin^2 \theta_i \tan^2 \theta_i} (r_{\perp}) \quad (15)$$

[†] $n = 1.517$; see Ref. 5.

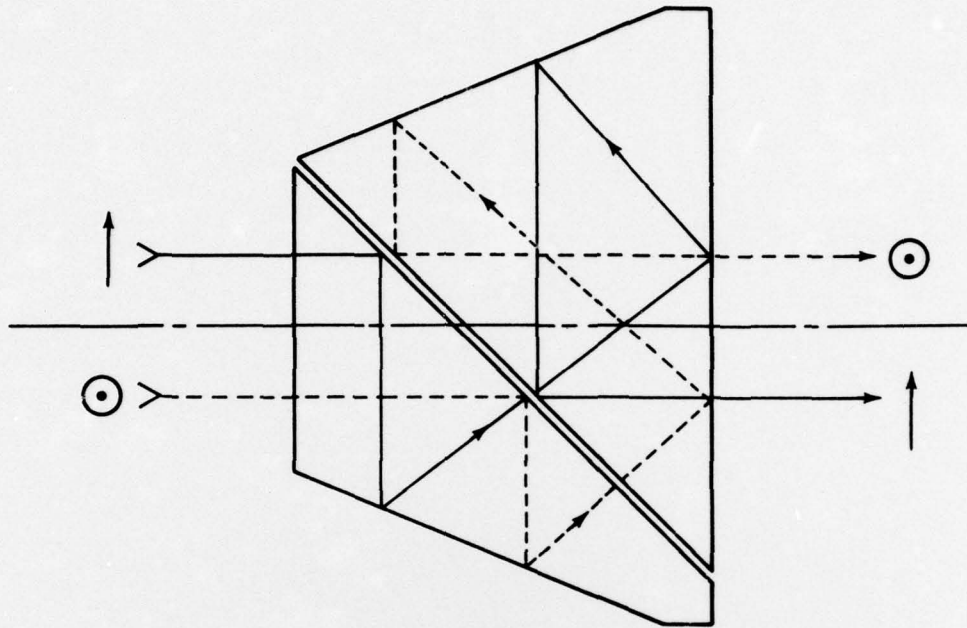

a) PECHAN SYSTEM

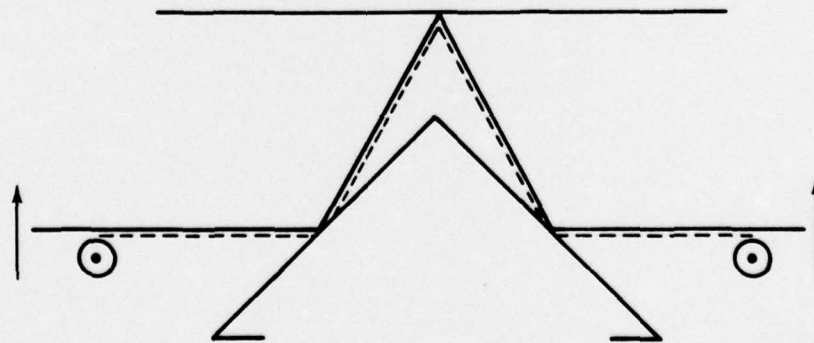

b) K-MIRROR SYSTEM

Fig. 6 Polarized Paths in Image Rotators

where

$$\begin{aligned}
 a^2 + b^2 = & \frac{1}{2} \left[n^2(1 - k^2) - \sin^2 \theta_i \right] \\
 & + \frac{1}{2} \left\{ \left[n^2(1 - k^2) - \sin^2 \theta_i \right]^2 + 4n^4 k^2 \right\}^{\frac{1}{2}} \\
 & + \frac{2n^4 k^2}{\left[n^2(1 - k^2) - \sin^2 \theta_i \right] + \left\{ \left[n^2(1 - k^2) - \sin^2 \theta_i \right]^2 + 4n^4 k^2 \right\}^{\frac{1}{2}}}
 \end{aligned} \tag{16}$$

and

$$a = \left\{ \frac{1}{2} \left[n^2(1 - k^2) - \sin^2 \theta_i \right] + \frac{1}{2} \left(\left[n^2(1 - k^2) - \sin^2 \theta_i \right]^2 + 4n^4 k^2 \right)^{\frac{1}{2}} \right\}^{\frac{1}{2}} \tag{17}$$

In these equations $n' = n - ik_0$ is the complex index of refraction and $k_0 = kn$ is the extinction coefficient. For glass $k = 0$ so the equations simplify considerably. Their use is mostly to determine reflection coefficients for the front surface mirrors in the K-mirror system. An opaque gold coating for example, has an index $n' = 0.331 - 2.329 i$ in the visible region. The equations give rise to angularly dependent reflectivities such as those shown in Fig. 7 from which we can determine the polarization variability for the angles of interest.

The curves in Fig. 7 have been obtained from a computation of Eqs. (14) and (15) with the help of Eqs. (16) and (17). With the aid of the ray diagram of Fig. 4 and the curves of Fig. 7 we can produce a heuristic argument that while the angles of incidence remain constant in both representative configurations, the orientation of the plane of polarization with respect to the plane of incidence changes. Thus, the output intensity

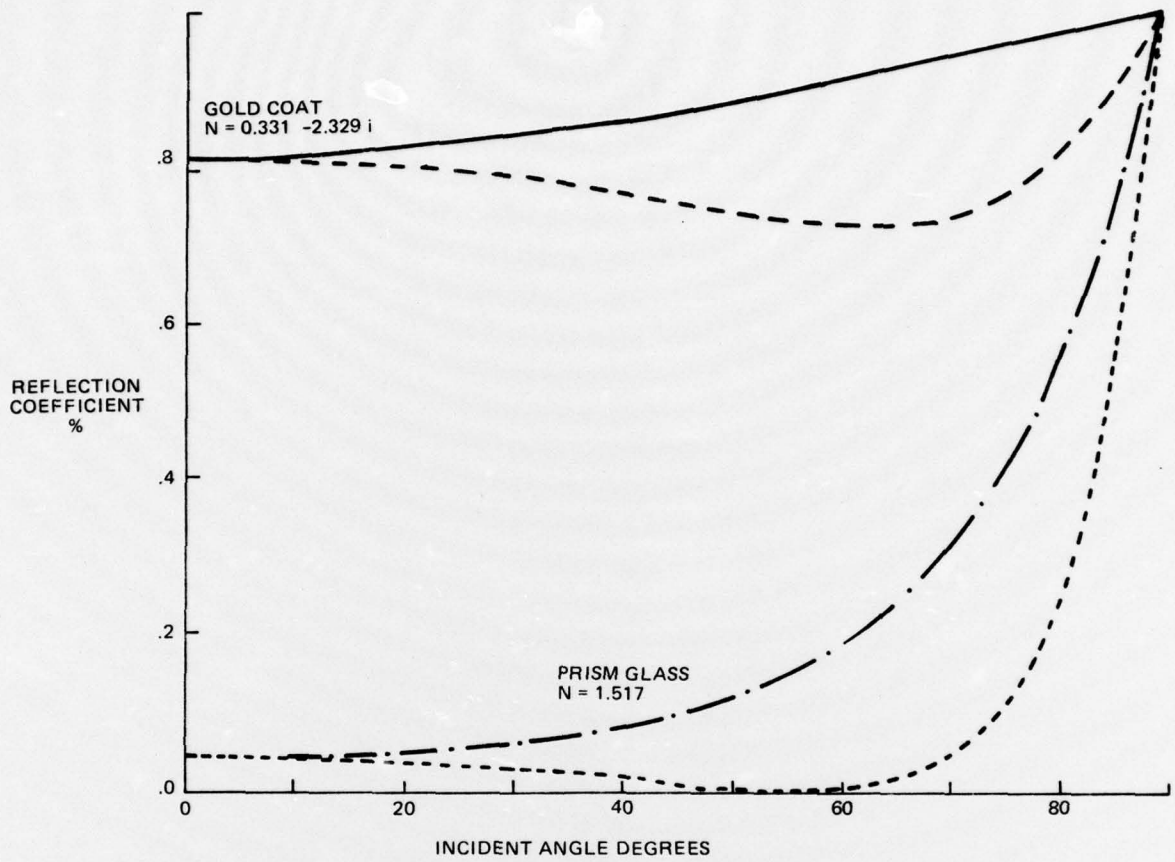

Fig. 7 Dependence of Reflection Coefficient Upon Angle of Incidence and State of Polarization

$$I_{\text{out}} = I_{\text{in}} \sum_{i=1}^j (1 - r_i) \quad (18)$$

varies, where the reflection coefficients r_i at each of the $i = 1, \dots, j$ surfaces can be obtained from the graphical information of the representative materials in Fig. 5.

If the illuminating laser were unpolarized, the

$$r_i = \frac{1}{2}(r_{\perp} + r_{\parallel}) \quad (19)$$

and the output intensity would be constant except, of course, by the image modulation.

Thus, in either of the cases discussed or for whatever class of image rotation devices they may represent, a linearly polarized laser contributes an amplitude modulation to the $I(r, \Delta)$ intensity of the image distribution. Since the variations in the r_i (Fig. 7) are relatively gradual for most angles of interest, the polarization effect will be negligibly affected by the presence of a wedge, for example, in the normal incidence prism class of devices.

This anomaly can be eliminated by use of an unpolarized laser whose output might be polarized by a crystalline prism of the Rochon or Taylor type only during matched filter fabrication.

3. CONCLUSIONS

Several conclusions can be drawn from the analyses performed on two representative image rotation devices which might be used in an optical correlator to reduce the requirements on storage capacity. The primary conclusion is that the normal incidence class of prisms require a parallelism tolerance of about a tenth of an arc second in order to work satisfactorily (i.e., for less than a 3 db decrease in an autocorrelation peak based upon a third order matched filter). Conversations with experts in the area indicate that the mechanical rotation could be held, coincidentally, to the same order of magnitude. Rotating mirror combinations also produce problems by rotating the polarization of the incident beam. However, since our concern about polarization occurs primarily during matched filter fabrication, the mirror system problems can be overcome by use of a nonpolarized laser. In fact, one might as a result of these analyses recommend that an optical correlator utilize a nonpolarized laser and whose "raw" beam contains a linear polarizer for use in making the matched filter. After that operation, the prism would be removed.

Finally, a "perfect" prism or one which can be compensated, for example, through a precision wedge, can be used to rotate imagery for correlation measurements provided that the prism length is not so long as to offset the image beyond other, optical component apertures in the correlator system.

4. REFERENCES

1. Van der Lugt, A. B., "Signal Detection by Complex Spatial Filtering," IEEE Trans. Inform. Theory, IT-10, No. 2, 1964.
2. Leib, K. G., Bondurant, R. H., and Hsiao, S., "Optical Matched Filtering Techniques for Automatic Interrogation of Aerial Reconnaissance Film," Final Report Contract DAAG53-75-C-0199, September 1976.
3. Almeida, S. and Kim-Tzong, Eu, J., "Water Pollution Monitoring Using Matched Spatial Filters," App. Opt., Vol. 15, No. 2, pp. 510-515, February 1976.
4. Bondurant, R. and Leib, K. G., "Birefringent Effects in Estar Base Reconnaissance Film in an Optical Correlator," to be published in Optics and Laser Technology, February 1977.
5. Optical Design-Military Standardization Handbook, MIL-HDBK-141, October 1962.
6. Simon, I., "Spectroscopy in Infrared by Refraction and Its Use for Highly Absorbing Substances," J. Opt. Soc. Am., Vol. 41, pp. 336-345, May 1951.

