

AD-A040 450

BOEING AEROSPACE CO SEATTLE WASH
STEREO ACUITY AND RECONNAISSANCE. PHASE I: DEVELOPMENT OF A PRE--ETC(U)
MAR 77 C D ANDERSON, C L KRAFT

AMRL-TR-76-112

F/G 17/8
F33615-74-C-4037
NL

UNCLASSIFIED

| OF |
AD
A040450



END

DATE
FILMED
7-77

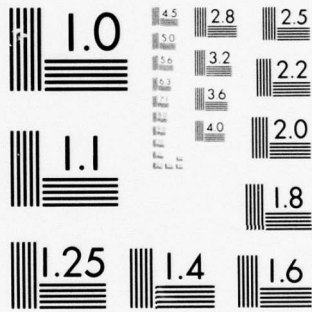

MICROCOPY RESOLUTION TEST CHART
NATIONAL BUREAU OF STANDARDS-1963-A

AD A 040 450

AMRL-TR-76-112



STEREO ACUITY AND RECONNAISSANCE Phase I: Development of a Precision Chromostereopsis Test and Test Equipment

THE BOEING AEROSPACE COMPANY
P. O. BOX 3999
SEATTLE, WASHINGTON 98124

MARCH 1977

Approved for public release; distribution unlimited

DDC
RECEIVED
JUN 10 1977
A

AD No. _____
DDC FILE COPY

AEROSPACE MEDICAL RESEARCH LABORATORY
AEROSPACE MEDICAL DIVISION
AIR FORCE SYSTEMS COMMAND
WRIGHT-PATTERSON AIR FORCE BASE, OHIO 45433

TICES

When US Government drawings, specifications, or other data are used for any purpose other than a definitely related Government procurement operation, the Government thereby incurs no responsibility nor any obligation whatsoever, and the fact that the Government may have formulated, furnished, or in any way supplied the said drawings, specifications, or other data, is not to be regarded by implication or otherwise, as in any manner licensing the holder or any other person or corporation, or conveying any rights or permission to manufacture, use, or sell any patented invention that may in any way be related thereto.

Please do not request copies of this report from Aerospace Medical Research Laboratory. Additional copies may be purchased from:

National Technical Information Service
5285 Port Royal Road
Springfield, Virginia 22161

Federal Government agencies and their contractors registered with Defense Documentation Center should direct requests for copies of this report to:

Defense Documentation Center
Cameron Station
Alexandria, Virginia 22314

TECHNICAL REVIEW AND APPROVAL

AMRL-TR-76-112

This report has been reviewed by the Information Office (OI) and is releasable to the National Technical Information Service (NTIS). At NTIS, it will be available to the general public, including foreign nations.

This technical report has been reviewed and is approved for publication.

FOR THE COMMANDER

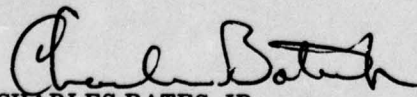
CHARLES BATES, JR.
Chief
Human Engineering Division
Aerospace Medical Research Laboratory

SECURITY CLASSIFICATION OF THIS PAGE (When Data Entered)

REPORT DOCUMENTATION PAGE		READ INSTRUCTIONS BEFORE COMPLETING FORM
1. REPORT NUMBER (18) AMRL-TR-76-112	2. GOVT ACCESSION NO.	3. RECIPIENT'S CATALOG NUMBER
4. TITLE (and Subtitle) (6) STEREO ACUITY AND RECONNAISSANCE, Phase I: Development of a Precision Chromostereopsis Test and Test Equipment.	5. TYPE OF REPORT & PERIOD COVERED (9) Final Report, Nov. 1973 - Dec. 1974.	6. PERFORMING ORG. REPORT NUMBER
7. AUTHOR(s) (10) Charles D. Anderson Conrad L. Kraft	8. CONTRACT OR GRANT NUMBER(s) (15) F33615-74-C-4037 new	
9. PERFORMING ORGANIZATION NAME AND ADDRESS The Boeing Aerospace Company P. O. Box 3999 Seattle, Washington 98124	10. PROGRAM ELEMENT, PROJECT, TASK AREA & WORK UNIT NUMBERS Project Number (16) (17) V1 61102F, 2313-V1-09	
11. CONTROLLING OFFICE NAME AND ADDRESS Aerospace Medical Research Laboratory, Aerospace Medical Division, Air Force Systems Command, Wright-Patterson Air Force Base, Ohio 45433	12. REPORT DATE (11) March 1977	
14. MONITORING AGENCY NAME & ADDRESS (if different from Controlling Office)	13. NUMBER OF PAGES 71 (12) 71 p.	
	15. SECURITY CLASS. (of this report) Unclassified	
15a. DECLASSIFICATION/DOWNGRADING SCHEDULE		
16. DISTRIBUTION STATEMENT (of this Report) Approved for public release; distribution unlimited.		
17. DISTRIBUTION STATEMENT (of the abstract entered in Block 20, if different from Report)		
18. SUPPLEMENTARY NOTES		
19. KEY WORDS (Continue on reverse side if necessary and identify by block number) Stereopsis Imagery, Chromatic and Achromatic Displays, Stereoscopic Chromostereopsis Chromatic Aberration Interpupillary Distance Exit Pupil Effects		
20. ABSTRACT (Continue on reverse side if necessary and identify by block number) A long focal length Badal optometer with a three-axis head positioner was designed, developed and used in investigations dealing with stereoscopic acuity and reconnaissance. The major effort was in the development of a precision chromostereopsis test, a short version of this same test and a foveal/parafoveal scan test. The Badal optometer provided the desired precision in the measurement of intervisual axes distance, interpupillary distance and →		

059610

next page

SUMMARY

PURPOSE

Generally:

To develop equipment, test materials and procedures to define and measure chromostereopsis in angular units.

More Specifically:

To develop a test for the rapid scanning of a population for the existence of varying degrees of chromostereopsis. In parallel, to develop a precision test that would be a sensitive, reliable and valid measure of chromostereopsis.

To develop equipment and techniques for the more precise measurement of interpupillary and intervisual axes distances and pupil size. With these tools to look for correlates among these variables as they relate to chromatic stereoscopic skills, and the direction and magnitude of chromostereopsis.

METHOD

A long focal length Badal optometer was designed, constructed and used to increase the precision of measuring the interpupillary distances, intercorneal reflection distances and intervisual axes distances of a group of 12 observers. A head positioner, artificial-pupil holder, and pupil size measuring device were also developed for use with the optometer. Special visual stimulus materials were designed and developed to constitute a precision chromostereopsis test that could be administered either in full or abbreviated forms. Also developed was a scan test employing a central (within fovea) disc to be compared with 12 concentric and stereoscopically displaced rings located between 2 and 9 degrees off axis (in the parafoveal region).

Twelve individuals with exceptional achromatic stereoscopic skills and with a stratification of chromostereoscopic effects were used in the evaluation of the precision and scan chromostereopsis tests. Five of the individuals participated in the measurements of various eye axes and in a study of how these measures were related to chromostereopsis.

Where appropriate, these data were tested to ascertain the possibility of rejecting the null hypothesis.

RESULTS AND CONCLUSIONS

Performance on the Peripheral Scan Chromostereopsis (PSC) test which compares foveal with parafoveal stereoscopic stimuli, correlates well ($r = .91$) with performance on the precision Alternating Ramp Chromostereopsis (ARC) test. The relative contributions of blue fields and red fields in the PSC test were never equal, as would be expected if chromostereopsis were the single contributing factor. Marked individual differences were found, with the maximum imbalance measured as 12.5 to 1. An explanation for such differences may reside in an interaction between the aspherical curvature of the retina and the refractive characteristics of the eye as they affect multicolored stimuli.

The precision ARC test measured individual differences in chromostereopsis in the range of 5 to 130 arc seconds. The ARC test performance predicted the use of long vs. short wavelength hues as answers in the CLST with a correlation of .92. The ARC test scores were used in conjunction with a theoretical attenuation model to predict chromatic stereoscopic performance. The ARC scores representing an increase in an individual's achromatic stereoscopic threshold imposed by the chromatic stereoscopic effect ($r = .714$ and $\sigma_{est} = 5.5$ arc seconds).

The ARC test also disclosed an unusual response pattern which appears to be a complex interaction among two or more effects.

With the ability to precisely measure the intervisual axes distance, the distance between the reflections of the entering rays of light, and the interpupillary distance, a trend has been observed. If the interreflections distance and the interpupillary distance are less than the intervisual axes distance, the individual generally sees long wavelength colors as advancing. If the separation of the entering rays' reflections and the interpupillary distance are greater than or equal to the intervisual axes distance, the individual generally sees short wavelength colors as advancing.

RECOMMENDATIONS

Chromostereopsis must be measured for each individual before stereoscopic performance with multihue imagery can properly be evaluated. The Alternating Ramp Chromostereopsis test provides a relatively fast, accurate and reliable measure of chromostereopsis in arc second units. More precision in setting the interocular distance of instruments than is currently available is necessary to minimize chromostereoscopic effects in binocular stereoscopic instruments. This recommendation of improved interocular control and greater precision in measuring the intervisual axes distance of the eyes of individuals applies only when multicolors are being viewed. No increased precision appears to be warranted for achromatic imagery. Visual displays that have stereoscopic reticles such as dots, small crosses, etc. should not utilize color in these reticles. Colored stereoscopic reticles may lead to larger three dimensional reading errors, even greater than that accounted for by chromostereopsis, under conditions of foveal vs. parafoveal color contrast.

PREFACE

This report was prepared by the Crew Systems organization of the Guidance and Control Engineering portion of the Research and Engineering Division of the Boeing Aerospace Company, Seattle, Washington. The work was done under USAF Contract F33615-74-C-4037 for the Visual Display Systems Branch, Human Engineering Division of the Aerospace Medical Research Laboratory at Wright Patterson Air Force Base, Ohio.

The authors are most appreciative of Don F. McKechnie's and Captain Frank Gomer's work and advice as monitors of this contract. Thanks are also due to Herman A. Hausle and James Geiger for their photographic skill and assistance; to Dr. S. J. Briggs for his statistical advice; to Richard J. Farrel for his consultation and assistance in spectrophotometry; and to Dr. Charles L. Elworth for his discerning review and communicative counsel.

TABLE OF CONTENTS

<u>SECTION</u>		<u>PAGE</u>
I	<u>INTRODUCTION</u>	1
	Color in Reconnaissance	1
	Chromatic Aberration	1
	Chromostereopsis	2
II	<u>THE PROBLEM</u>	4
	Chromostereopsis Measurement	4
III	<u>METHOD</u>	5
	Replacement of the Conventional IPD Measurement Tool	5
	The Clinical Method	5
	The Experimental Apparatus	6
	Design Criteria	6
	Badal Alignment Procedures	8
	Head and Eye Positioner	8
	Corneal Positioner	8
	Artificial Pupil Holder	11
	Pupil Size Measuring Device	11
	The Use of the Badal Optometer in Measuring IPD and IBXD	11
	Development of the Precision Chromostereopsis Test	14
	Early Development of a Quantitative Chromostereopsis Test	14
	Development of the Refined or Precision Chromostereopsis Test	14
	Calculation of Disparity in the ARC Series	19
	Testing Procedure and Scoring With the ARC Series	20
	The Development of a Peripheral Scan Chromostereopsis Test	22
	Foveal vs. Peripheral Chromostereopsis	22
	Peripheral Scan Test Procedure	23
	General Procedure in Evaluations	26

<u>SECTION</u>		<u>PAGE</u>
IV	<u>RESULTS AND DISCUSSION</u>	28
	The Inter-Behavioral Axes Measurement	28
	The Narrow-Aperture Adjustment Method	29
	The Intermirror Adjustment Method	29
	The Corneal Reflection Method	29
	The Distance Between Similar Edges of the Iris Method	29
	Comparison of "IPD" Measurement Methods	30
	The Effects of Alignment Error Using Artificial Pupils	30
	The Physiological - Optical Correlates	33
	The Parafoveal Scan Test Results	37
	The Precision Chromostereopsis Test (ARC) Results	39
	The Analysis of an Unusual Response Pattern	48
V	<u>CONCLUSIONS</u>	53
 <u>APPENDIX I</u>		
Fig. I-1	Primary Dimensions on Physical Model	54
Fig. I-2	Principle Dimensions of Camera Setup Used to Take Stereo Photographs	55
Fig. I-3	Stereo Disparity Formulae	56
 <u>APPENDIX II</u>		
Fig. II-1	ARC Test Response Sheet	57
 <u>APPENDIX III</u>		
Fig. III-1	Peripheral Scan Chromostereopsis Test Data Sheet	58
 <u>REFERENCES</u>		 59

LIST OF ILLUSTRATIONS

<u>FIGURE</u>		<u>PAGE</u>
1	Long Focal Length Badal Optometer	7
2	Plan View of Badal Alignment Procedures	9
3	Head Positioner Mounted on Badal Optometer	10
4	Schematic Drawings of Three Devices	12
5	Model of ARC Test of Chromostereopsis	17
6	The Effect on Chromostereopsis of Decentering 2 mm Artificial Pupils	32
7	Frequency of Use of Long Wavelength Colors as "Near" Answers as Related to Devi- ations of Natural Pupils and Reflections Relative to Behavioral Axes for Five Observers	36
8	The Proportion of Use of Long and Short Wavelength Colors in the Chromatic Stereoscopic Test as a Function of Chromostereopsis for Ten Observers	41
9	Stereoscopic Skill Attenuation as a Function of Chromostereopsis	45
10	Prediction of Stereoscopic Skill With Chromatic Imagery by Knowing Chromostereopsis and Achromatic Stereoscopic Skill	46
11	Response Distribution by Row Pairs for Observer #1 on Achromatic and Chromatic Versions of Format B of ARC Test	49
12	Distribution of Responses on Six Formats of Achromatic ARC Test	50

LIST OF TABLES

<u>TABLE</u>		<u>PAGE</u>
1	Frequency of Occurrence of Response Patterns That Fit Explanations Other Than That of Hue Derived Stereopsis	16
2	Dimensions and Displacements of the Disc and Rings in the Peripheral Scan Chromostereopsis Test as Viewed in the A.O. Troposcope or at a Magnification of 1.23	24
3	Reliability of the IBXD Method on the Badal	30
4a	Reflection and Pupil Sizes in Badal During Investigation of IBXD Methods	34
4b	Tests of Significance For Differences in Reflection Size	34
5	Relationships Among IBXD, Centers of Pupils, and Centers of Entering Luminance Rays	35
6	Correlations Between Performance on Scan and ARC Tests of Chromostereopsis and the Frequency of Use of Long Wavelength Hues as Answers on the Chromatic CLST	38
7	Difference Scores Between Red-Field and Blue-Field Peripheral Scan Chromostereopsis Tests	40
8	Test-Retest Reliability of CLST Scores With Two Year Interval Between Tests	43
9	Prediction of Stereoscopic Skill With Chromatic Imagery From Chromostereopsis and Achromatic Skill	44
10	Analysis of Variance for Achromatic-Chromatic Difference Scores on the ARC Tests	47
11	Correlation Matrix Among the Five Factors Which May Contribute to the Rhythmic "Layback" Response Pattern	52

SECTION I
INTRODUCTION

COLOR IN RECONNAISSANCE

The transformation of pictorial reconnaissance data into intelligence information remains a man-machine endeavor. With the advent of Estar-base aerial color films such as SO-242 and SO-255, high resolution chromatic imagery is available and, for best utilization, must be displayed to man with a minimum of attenuation in image quality.

This research program is looking into some of the characteristics of man's visual system, including his perception of color, which would impact display design and information extraction procedures. One of the possible advantages of color may be the improvement in the perceptual contrast of a target. When chromatic strip reconnaissance imagery is displayed stereoscopically, individuals with excellent chromatic stereoscopic skill can exceed their own target acquisition performance attained on a binocular non-stereoscopic display. (Kraft and Anderson, December, 1973a). Individual target acquisition performance on moving strip color imagery displayed in stereo could be predicted ($r = .81$) from scores on a chromatic, dynamic, stereoscopic test.

CHROMATIC ABERRATION

The differential bending of light of different wavelengths causes both spherical and lateral chromatic aberration in optical devices and in the human eye. The control of chromatic aberration in optical equipment is an everyday affair for equipment designers. An almost complete elimination of chromatic aberration is possible by the addition of a special lens (Bedford and Wysecki, 1957) but such lenses are not prescribed nor worn in general practice.

Chromatic aberration, however, has a special effect on the person viewing a stereoscopic display of two or more hues as saturated patches of light seen against a black background. If the viewing instrument has oculars that can be moved laterally (as most instruments do to adjust for the individual differences in distance between the pupils) and the effective exit-pupil size is small in diameter (1 mm), the following may be seen: in/out movement of the oculars, for example first in the temporal direction and then toward the nose, will be associated with a perceived Z-axis motion of the different hues in the display. That is, if the display scene is a line of colored discs seen against a dark field, the temporal-nasal alternation of the oculars induces a perceived motion like pistons in an automobile engine when viewed from above. When moving the oculars from a temporal to a nasal position, the long wavelength hues recede as the short wavelength hues advance, and conversely, the direction of the apparent motion reverses as the direction of the ocular motion is reversed. The apparent magnitude of the Z-axis motion is a function of individual differences in chromostereopsis, the saturation of the colors and the amount of movement of the oculars.

CHROMOSTEREOPSIS

The term "chromostereopsis" (Vos, 1966) refers to the illusion of differential depth experienced when various colored patches located on a single-plane surface are viewed binocularly. The phenomenon has been known for many years by students of vision (Bruecke, 1844), and described as "Stereoscopie durch Farbendifferenz" (Einthoven, 1885), as "Farbenplastik" (Peuker, 1898), as "retreating and advancing colors," (Luckiesch, 1918), or as "Farben Stereoskopie" (Liesegang, 1944). Several authors have advanced theories to explain the phenomenon and the general extent of its influence (Rosch, 1954; Vos, 1960; Kishto, 1965).

In 1972, Kraft, Booth, and Boucek reported results of a study in which depth discrimination was measured for both chromatic and achromatic stimuli. The findings were consistent with the theory that chromostereopsis is caused by the differential dispersion of colored light. This dispersion is imposed by the chromatic aberration of the human eye, and its magnitude and direction are individualized by the combined effects of eye axes. These individual differences were used to separate the observers into three groups: a small neutral representation, and two larger but equal groups, one seeing long wavelength colors nearer than short wavelength colors, and the other group seeing the converse.

The study of Kraft and Anderson (1973a) found similar individual differences in the direction of chromostereopsis and both investigations found about 18 percent loss in performance on a chromatic stereo-acuity test, as compared with the test's achromatic version. This decrement encouraged the authors to recommend that chromostereopsis be measured for each individual before stereoscopic performance with multi-hue imagery is evaluated.

Later the same year Kraft and Anderson (1973b) developed a quantitative test for chromostereopsis and administered it to sixty-three individuals. Performance only partially predicted ($r = +.65$) the difference between these individual achromatic and chromatic stereoscopic skills. A factor of accommodation insufficiently may have contributed to this incomplete prediction, but the authors were of the opinion that limitations in the chromostereopsis test may have been the larger contributor. Improvement in the control of accommodation, the quality of the chromostereopsis test, and in matching the separation of the interoculars to the interpupillary distance should significantly improve the measured correlation.

Owens and Leibowitz (1974) added data to the question of the importance of knowing more about chromostereopsis and its relevance to the use of binocular instruments with typically small exit pupils. **They concluded:** "Under such conditions, the size of the illusory depth effect resulting from chromostereopsis not only represents a strikingly large error, but also can be expected to vary with slight changes in the interpupillary distance settings of the instrument. This represents a very real problem for optical instrument design since:

- 1) Small variations in interpupillary distance result in large changes in chromostereopsis; and
- 2) Few of the presently available instruments make provision for accurate setting of interpupillary distance."

SECTION II
THE PROBLEM

CHROMOSTEREOPSIS MEASUREMENT

The goals of Phase I of this three-phase contract were:

- . To develop the necessary equipment, test materials and procedures to quantify and define chromostereopsis in angular units;
- . To use these tools to predict the individual's chromatic stereoscopic skill from his achromatic stereoscopic performance;
- . To eventually predict his target acquisition performance with chromatic stereo strip imagery;
- . To develop and evaluate special equipment for the measurement of interpupillary distance, intervisual axes distance, and pupil size. This intermediate step is necessary in order to resolve the other major problem areas;
- . To measure the interrelationship between eye axes, on one hand, and chromostereopsis on the other, in order to better define the phenomenon of stereopsis;
- . To determine if the chromostereopsis test may be used in "scanning" the phenomenon in large populations as well as for the precise measurement of this phenomenon among selected individuals.

SECTION III

METHOD

REPLACEMENT OF THE CONVENTIONAL IPD MEASUREMENT TOOL

To obtain a starting point for the research, it was first necessary to develop a valid and reliable method of measuring the distance between the visual axes of the individual's two eyes.

The Clinical Method

The clinical method is widely used by ophthalmologists and optometrists in clinical refractions. This method was also used by Hertzberg in his anthropometric study of Air Force personnel in 1950. The method is described by the instructions included in WADC-TR-52-321:

"To measure the distance between the subject's pupil centers, instruct him to look at whichever eye you hold open. Rest the sliding caliper lightly on his face, close your right eye, and center the fixed tip before his right eye. Now, open your right eye, close your left one, and center the sliding tip before his left eye. Do not allow his head, your head, or the caliper to move during the measuring." (Hertzberg, 1954.)

This USAF study had an N of 4063 people and provided the information that mean interpupillary distance (IPD) was 63.27 millimeters, the standard deviation 3.64 and the inclusive range 51 to 76 millimeters. However, a much smaller sample provided data which left the reliability of this method of measurement open to question. In two prior contracts, the authors (Kraft and Anderson) used the clinical method of IPD measurement to match the interoculars of the Sonne SC-2 Stereo Strip Viewer to the observer's IPD. These two samples were drawn from a general population and subsequent selection was based on visual skills. There were ten individuals from the first sample that were used in the second sample and on which two separate IPD measurements were taken. The variances for these two sets of IPD measurements were not consistent ($s^2 = 16.7\text{mm}$ vs. $s^2 = 5.8\text{mm}$), while the variance for the before-mentioned larger population (N = 4063) fell in between ($\sigma^2 = 13.3\text{mm}$). It appeared that the measurement of IPD using the clinical method was not very reliable. The estimate of reliability was a ratio of the variance between the first and second measurements to the variance among the ten observers. This reliability was much lower ($r = .82$) than that required by the sensitive phenomenon being studied. It was the authors' goal to develop a measure that had a reliability of .98 or better. To achieve this, it was determined that a specialized piece of equipment would be needed. This measured reliability level also was judged to be excessive for research employing chromatic stimuli, and emphasized the need for a specialized, precision measuring tool.

The following factors may contribute to the poor reliability of the clinical method:

(1) Variance Contributed by the Observer:

- (a) Accommodation or visual focusing for near ("looking at experimenter's eye") will differ from looking at a distant object over the experimenter's head. With this change in focus will be some change in convergence of the eyes.
- (b) Illumination differences change pupil size and may change convergence angle.
- (c) Inability to maintain fixation for an extended period of time.
- (d) The physical and behavioral axes of the eye are most likely to be different, and the apparent center of the pupil may not lie on either axis.

(2) Variance Contributed by the Experimenter:

- (a) Errors due to moving the scale.
- (b) Errors in reading the scale.
- (c) Errors due to parallax between his and the observer's eyes.
- (d) Variations among experimenters in techniques and in observation distances used.

THE EXPERIMENTAL APPARATUS

Design Criteria

The apparatus was designed to provide control of convergence, accommodation, illuminance and illuminance hue. Convergence was to be adjustable between 0° (parallel) and 10° , accommodation between 0 and 2.5 diopters. Illuminance intensity between 5 and 2000 ft.c. was to be available with hues between saturated blue and saturated red. The apparatus was to be capable of IPD measurements between 51 and 76 millimeters, the total range in the USAF sample.

The form of the apparatus was that of a Badal Optometer with 25mm mirrors before the eyes and 381mm focal length, 80mm diameter, achromatic lenses. The apparatus was mounted on a high aluminum bench with an adjustable head-rest and chin rest. Figure 1 illustrates these features. The right eye mirror was fixed while the left eye mirror was fitted with a micrometer adjustment with motion parallel to the central ray of the 381mm lens.

The illumination sources were horizontally mounted DeJur II enlargers without the objective lenses, film carrier and bellows. These double condenser sources may be fitted with 75, 150, or 250 watt enlarger lamps. The horizontal mounting reduces the effectiveness of convection cooling

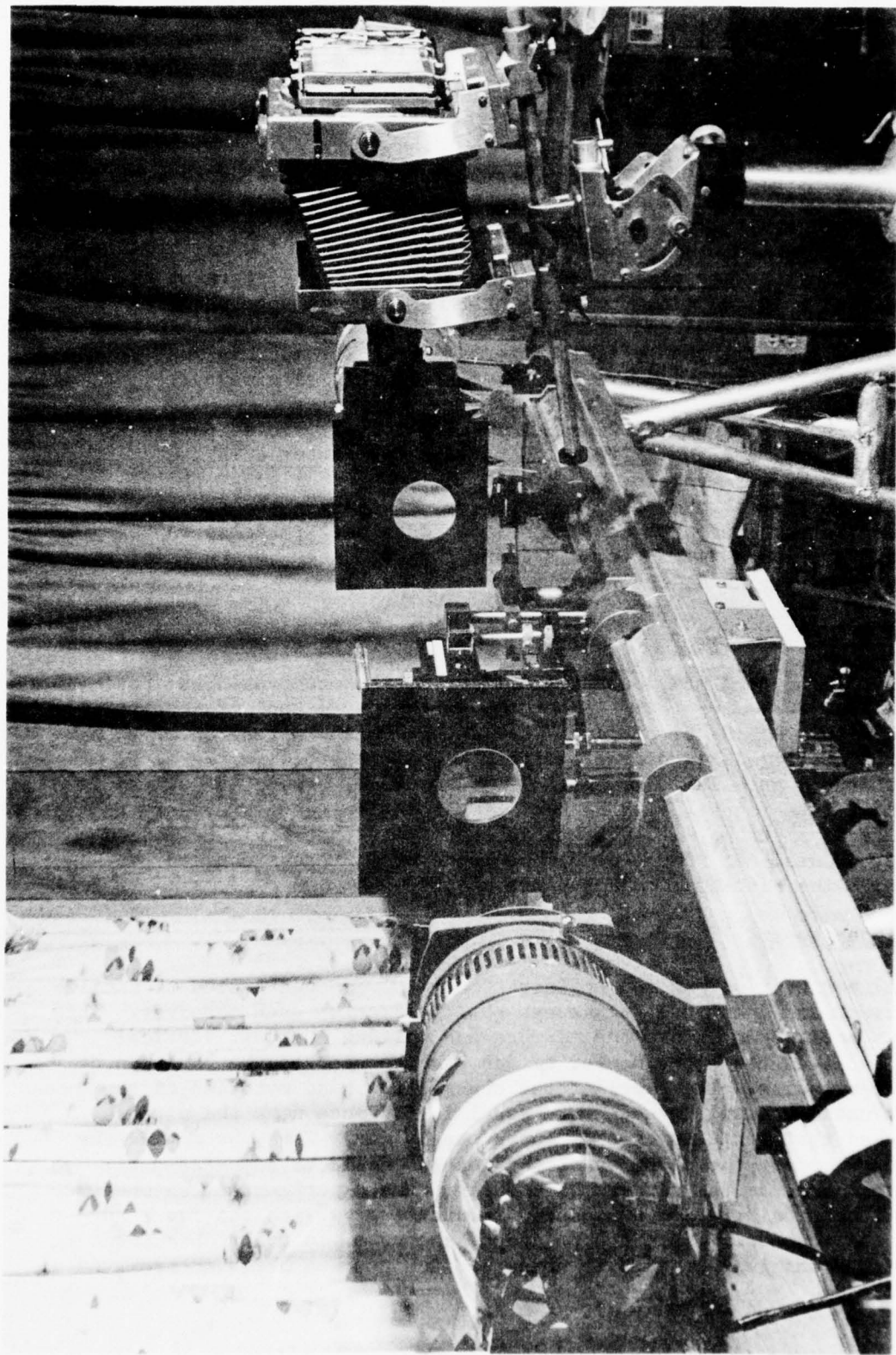

FIGURE 1. LONG FOCAL LENGTH BADAL OPTOMETER

so two 14 watt muffin fans, one per source, were added to provide a forced air flow past lenses and lamp.

Badal Alignment Procedures

Two neon-helium, 2 milliwatt lasers were mounted side-by-side so emerging beams were parallel and separated by 72.25mm. These lasers were then mounted on a heavy tripod, raised to the Badal eye level and the laser beams made horizontal. Horizontality was tested over a 7 meter distance. The lasers were positioned 2.4 meters from the mirrors of the Badal so that when the front surfaces of these mirrors were parallel to the arms of the Badal and perpendicular to the laser beam, this beam was returned down the path of the emerging beam. The mirrors must be perpendicular in both X- and Y- axes to achieve this alignment.

The mirrors were then set 72.25mm apart (with the artificial pupils also at 72.25mm apart) and the diffraction pattern was centered in the apertures. When the mirrors were rotated 45° around their vertical axes, the reflected beams pass through the lens centers, contacting the tip of the cones, and intersecting the centers of the cross hair reticles on the illuminators (figure 2). This must occur for both legs of the Badal to a criterion of $\pm .5\text{mm}$ at the reticles.

Head and Eye Positioner

In order to achieve precision and stability of the observer's eye positions, it was necessary to implement the laboratory method of supporting the head with a rigid "bite-board," holding a dental impression of each observer's teeth. A six degree of freedom positioner, with the X, Y, and Z motions controllable to 0.1, 0.1 and 0.025mm, respectively, was constructed (see figure 3). The head tip, rotation, etc. necessary to match bite asymmetries were adjustable parameters that could be locked in place. Dental wax was used to make the dental impressions and remained with the bite-board and support block.

Corneal Positioner

A special bar with prisms and registration pins was constructed to facilitate correct and identical Z-axis eye positioning for each observer. This bar, when positioned before the mirrors and resting on their vertical support, allowed the experimenter to see each cornea and the position of the reference pins. The experimenter changed the head rotation of the observer until the two corneas were equal in distance from the mirrors, then locked that position on the mouthpiece holder. Then, by moving the Z-axis micrometer, the location of the corneas could be adjusted until they were 55mm from the mirrors, a condition the experimenter can observe by the visual registration of the two reference pins with the front surface of the corneas. Since the bridge of the nose generally obscures simultaneous observation of both corneas, each eye was observed from the temporal side.

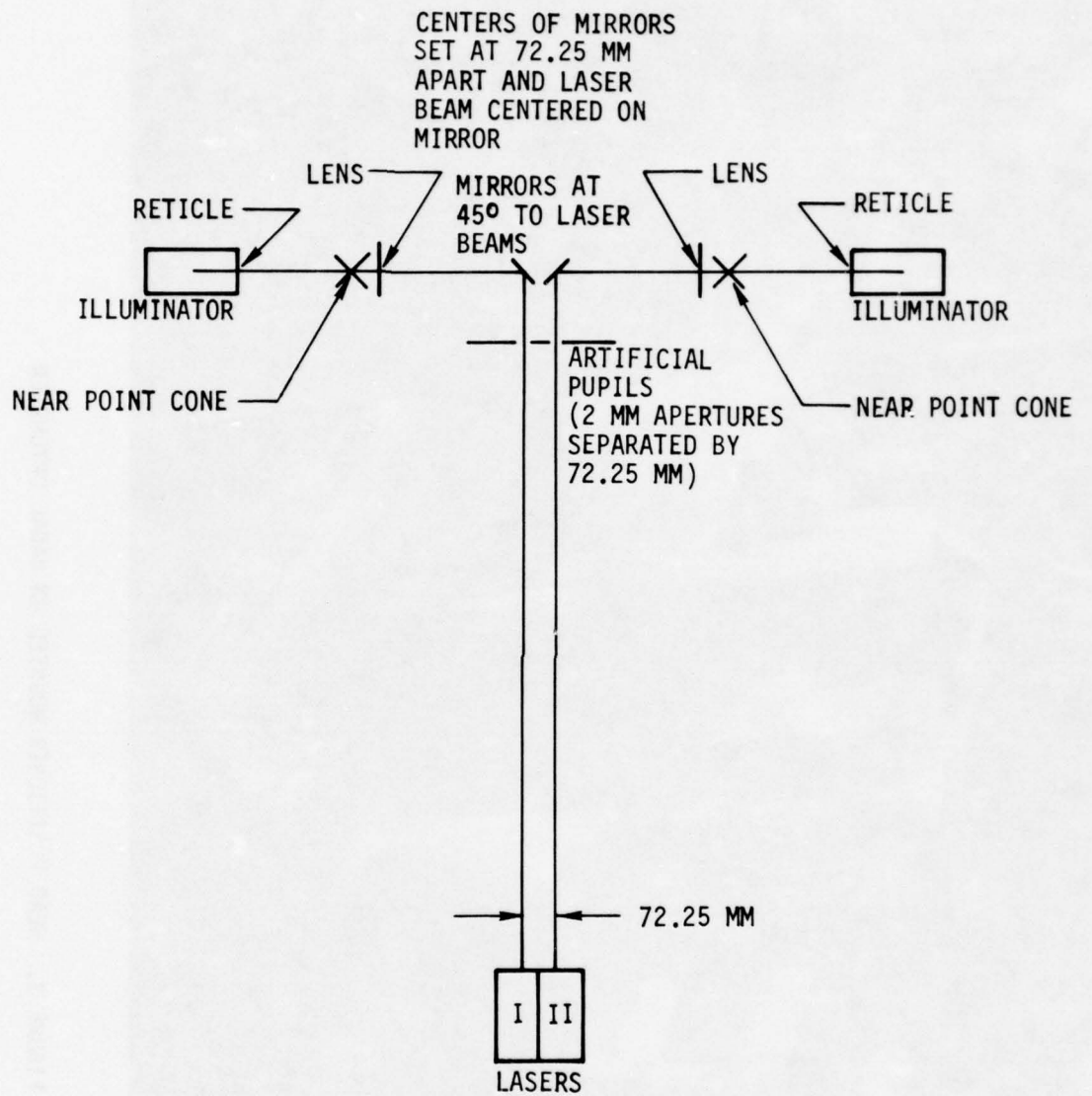

FIGURE 2. PLAN VIEW OF BADAL ALIGNMENT PROCEDURES

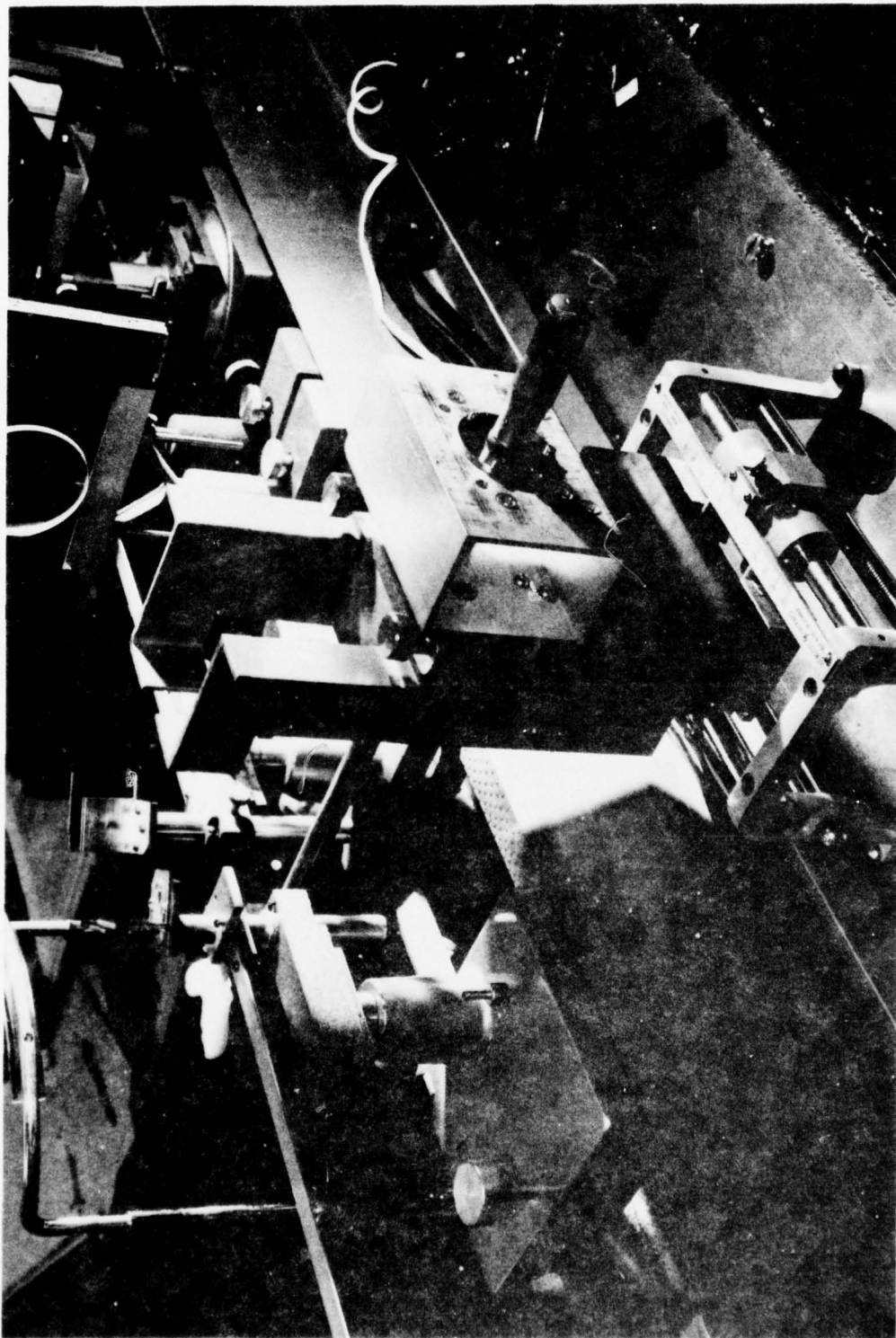

FIGURE 3. HEAD POSITIONER MOUNTED ON BADAL OPTOMETER

Artificial Pupil Holder

The apparatus was designed such that, between the Badal mirrors and the observer's eyes, and at 5mm from the corneas, artificial pupils of different diameters could be introduced (see figure 4). The position of each artificial pupil could independently be moved horizontally to a scale accuracy of 0.1mm. The initial work was done with 2mm diameter artificial pupils.

Pupil Size Measuring Device

Pupil size was measured by a small device which utilized a circular sheet of photographic film which could be rotated before the natural pupil so that any of 29 pairs of 1mm apertures could be brought into alignment with the natural pupil (see figure 4). The separation between the paired 1mm apertures varied from 1 to 8mm in 1/4mm steps. The observer selects the pair which gives him the perception of two just-touching illuminated discs. The physical separation of the centers of the pair of apertures selected is a good estimate of the natural pupil size.

The Use of the Badal Optometer in Measuring IPD and IBXD

The clinical method, discussed earlier, measures the distance between the centers of the pupils (IPD). The design of the Badal optometer also allowed a measurement of IPD on photographs of the eyes taken while the observer was forced to hold the right and left eye lines of sight parallel. For many if not most individuals, the line of sight does not pass through the center of the pupil, but may be either temporally or nasally displaced. Thus, the distance between the lines of sight (an interbehavioral axes distance) may be different from the IPD for many individuals.

The interbehavioral axes distance (IBXD) is the physical distance between the right and left eye visual axes (as defined by Duke-Elder, 1970) when they are parallel. In the Badal optometer, this was accomplished by placing visual reference pointers on the aligned Badal and verifying registration along the visual path of each eye from 2.5 diopters to infinity focus. Subsequent research has indicated that the interbehavioral axes distance (IBXD) was statistically significantly different from the inter-pupillary distance (IPD) for a small group of observers (N = 5). This difference is important in the study of chromostereopsis and therefore both measures are referred to in later discussions.

The detailed procedure for determining the interbehavioral axes distance (IBXD) with the Badal optometer was as follows:

- 1) Check alignment of Badal with laser technique.
- 2) Make a dental impression of the observer's bite.
- 3) Attach bite-plate to support block and Z-axis rod.

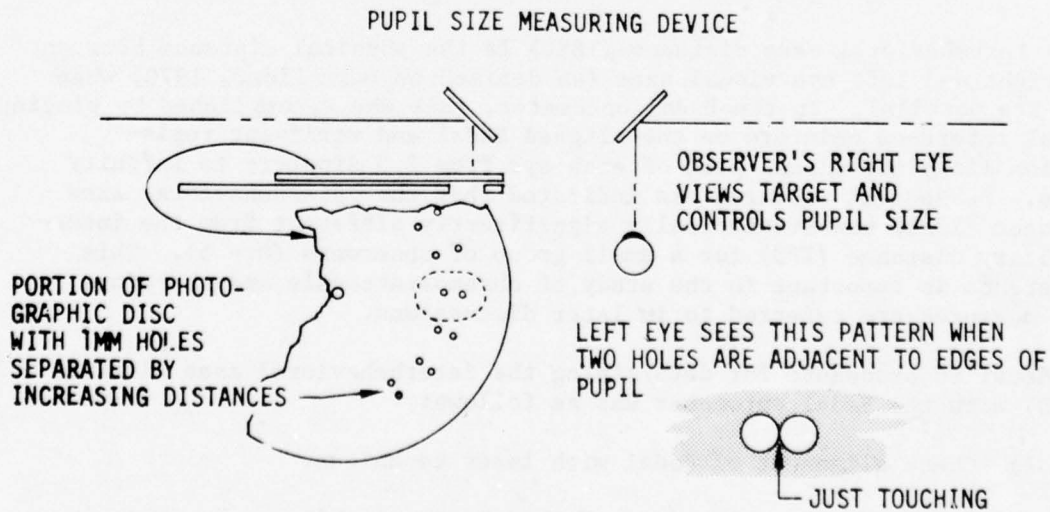
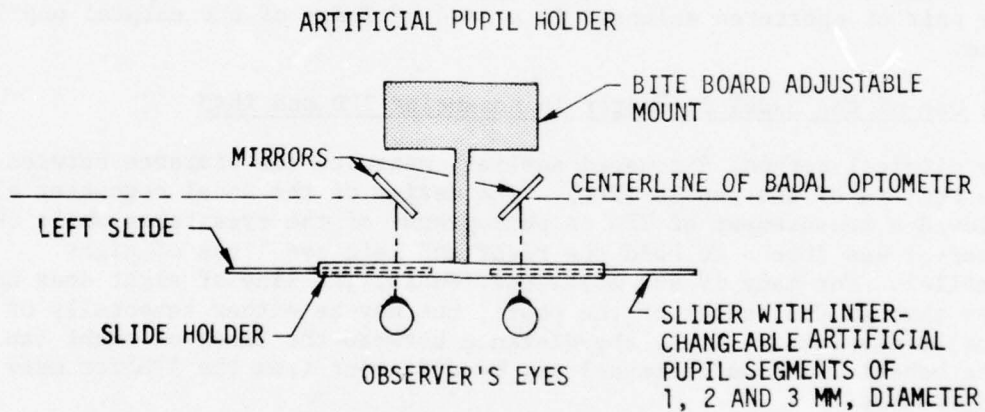
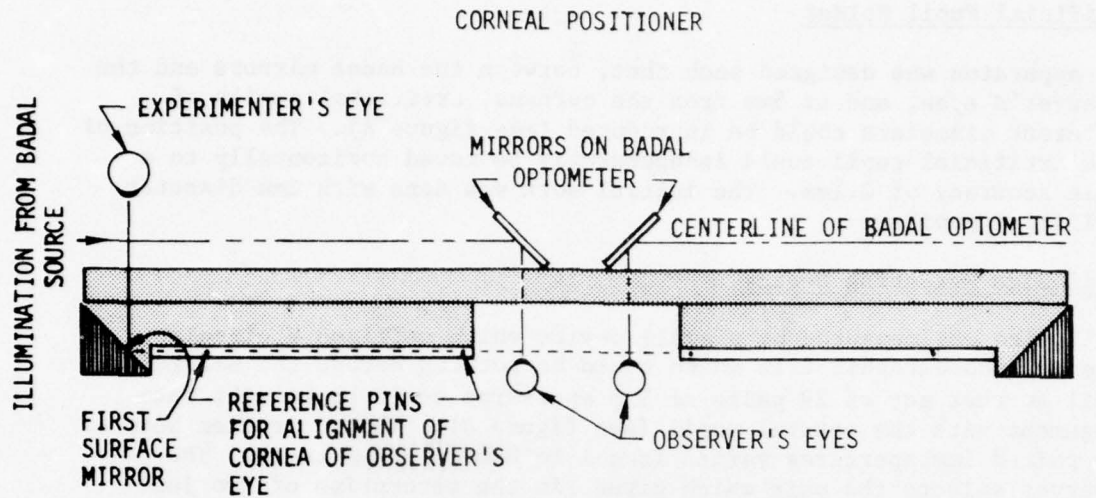

FIGURE 4. SCHEMATIC DRAWINGS OF THREE DEVICES

- 4) Position the artificial pupils at an approximate IBXD setting and use these as an eye height reference. Set height of eye position by adjusting Y-axis of micropositioning device so that the observer can see through artificial apertures. Then remove artificial pupils.
- 5) Install corneal positioner and adjust Z-axis until cornea aligns with double reference pins on right side. Then check left side. If left cornea is also aligned, note the micrometer position and lock Z-axis bar in place. If left cornea is not aligned, rotate bite plate around its vertical axis on alignment block until both corneas are equal in distance from reference pins, then reset Z-axis to align corneas with reference pins.
- 6) Set up near-point reference cones at 38.2mm from nodal point (object to lens) or at 2.3 diopters of visual accommodation.
- 7) Set up photographic cross-hair reticles at 374.2mm from the nodal point or at zero diopters of accommodation.
- 8) With illuminators turned on, move X-axis of eye positioner until right eye position allows observer to see cone and reticle in alignment. Lock X-axis.
- 9) Then move left eye mirror temporally or nasally until the observer sees the left hand cone and reticle aligned.
- 10) Record the three values for X-position for right eye, separation of left mirror from right, and Z-axis position. It is the second value that gives the interbehavioral axes distance (IBXD).
- 11) If artificial pupils are to be used, they are positioned before the eyes so that the cones and reticles remain aligned, and the values for these positions recorded.

The size and position of the pupils, irises and Badal light source reflections for both eyes were recorded with a long focal length camera. The most successful camera tested was a 4" x 5" view camera fitted with an 8" copy lens, the bellows extended to 16.5 inches and the lens-to-object distance at 16.4 inches. This arrangement gave an approximate one-to-one object-to-photograph ratio. The actual ratio was measured and used as a constant. The alignment of the camera was along the center-line of the observer's head, the eyes viewed over the tops of the mirrors.

The size and separation of the images were measured with a Mann comparator and recorded to the nearest 0.001 millimeter. A second constant was introduced to correct for the radius of curvature of the cornea in determining the interreflection distances. No correction was applied to the interpupillary distance, as pupillary photographs with a camera-to-eye angle of 4.35° do not significantly distort the height-to-width ratio of the pupil (Haines, 1969).

DEVELOPMENT OF THE PRECISION CHROMOSTEREOPSIS TEST

Early Development of a Quantitative Chromostereopsis Test

In the Kraft and Anderson (1973a) study, the direction of chromostereopsis was determined for each subject using the "two-dot" test. The results of this study indicated that any effect of chromostereopsis on target acquisition performance would be predictable only if both its direction and magnitude were known. With a new design format, it appeared possible to quantify the amount of shift due to chromostereopsis by presenting to the observer a pair of rows of discs in which the disc heights or disparities were arranged in an alternating ramp configuration.

The discs were arranged in three pairs of rows with eight discs in each row. In each pair, one row contained red discs, the other blue. Both rows had disc "heights" or disparities which followed a linear ramp function from one end of the row to the other, with the condition that the direction of the ramp was always opposite for the red versus blue row in each pairing. Thus, there was always a column position or "crossover point" where a single red/blue disc pair would be at the same height. The task was to locate the single pair which appeared to be an equal distance away from the observer when viewed through the Wottring Troposcope. This could occur under any column heading from 2 to 9. For a person with considerable chromostereopsis, it might not occur, that is, for that particular pair, all the discs of one color could appear "higher" than any of the discs in the other row. For an observer with "red advancing" chromostereopsis (sees red closer than blue when they are really at the same distance), the crossover point could shift toward the end of the row where the blue discs are actually higher than the reds. A shift of one column (step interval) was equal to 12 seconds of arc disparity for the "72" series, 24 seconds for the "36" series, and 48 seconds for the "18" series. Six pairings on each series were given each observer, for a total of 18 data points per observer. Results of the administration of this test were presented in the documentation of the 1973 study, under USAF Contract F33615-73-C-4034 (AMRL TR-73-104).

Development of the Refined or Precision Chromostereopsis Test

The refined form of the chromostereopsis test was developed with the objective of overcoming limitations found in testing with the preliminary test, thereby expanding the capability and precision of the test. Development began with a review and analysis of the testing done in the earlier investigation. In this study, 61 observers were given two formats each of three different series of the test, those with disparity step intervals of 48, 24 and 12 arc seconds. The range of disparities in the three series also varied, being proportional to the step interval, with magnitudes of 336, 168 and 84 arc seconds, respectively. A cursory analysis of the response data of these 61 observers suggested several potential limitations in the test which might have been responsible for the observed phenomena in which:

- 1) Twenty six of the observers were unable to discriminate disc-to-disc disparities on the "72" series sufficiently to respond, while two had the same problem on both the "36" and "72" series;
- 2) For some of the observers, there was a tendency for the individual's chromostereoscopic shift (as determined by his responses) to vary directly as a function of the size of the step interval and/or disparity range of the different series.

Several hypotheses (potential limitations of the test) were examined as explanations for the observed anomalies:

- (a) The disparity step intervals in the "72," and for some in the "36" series, may have been below the stereoscopic thresholds of the observers who were unable to make discriminatory responses;
- (b) The crossover point location pattern was common for all three series, which may have led observers to a repeat of responses used on the easier "18" series test (administered first to all observers) during the more difficult "36" and "72" series;
- (c) The reduction of disparity step interval and range across the three test series may have resulted in a response adaptation which effectively reduced the chromostereoscopic shift from the "18" series to the "72" series of the test.

To test these hypotheses, the 64 observers were divided into three groups, and their data analyzed:

- 1) Those 14 observers whose magnitude of chromostereoscopic shift showed a 50 percent or more reduction from the "18" series to the "36" series;
- 2) Those 10 observers whose magnitude showed at least a 50 percent reduction from the "18" series to the "36" series, and also a 50 percent reduction from "36" to the "72" series; and
- 3) The remaining 37 observers.

Table 1 contains the results of this initial review. The frequency of response patterns that could be explained by simpler hypotheses is significant but not overwhelming for these 24 individuals. The percentages should not be summated as two or more explanations may fit the responses of a single individual. It may also be noted that the 24 individuals represented 37.5% of the population. The remaining 62.5% had consistent chromostereoscopic responses on two or more of the tests and seemed not to be influenced by the size of the step interval nor by the pattern of crossover points.

TABLE 1. FREQUENCY OF OCCURRENCE OF RESPONSE PATTERNS
 THAT FIT EXPLANATIONS OTHER THAN THAT
 OF HUE DERIVED STEREOPSIS

<u>Hypothetical Explanations</u>	<u>Group I (N = 14)</u>	<u>Group II (N = 10)</u>
1. Ss used similar numbers	0(0%)	0(0%)
2. Ss used a visual pattern in repeating responses	3(21%)	2(20%)
3. Ss response patterns not consistent across/within the series	6(42%)	4(40%)
4. Ss achromatic stereoskill below 32 arc seconds	1(7%)	2(20%)

One further evaluation was completed, i.e., correlation was between the expected effect of the measured chromostereopsis on the attenuation of the observer's performance with chromatic stereoscopic skill test versus his achromatic test score. The rationale behind this correlation will be developed later when the same technique is used to measure the improved performance attained with the refined chromostereopsis test.

The resulting correlation ($r = .134$) is not high and represents a forecasting efficiency of less than 1% for this subsample of 24 individuals. This review to the results of testing with the preliminary chromostereopsis test led to the formulation of design goals for the refined version of the test.

The specific improvements and features in the refined "ARC" test (Alternating Ramp or Anderson Ramp Chromostereopsis Test) include the following:

- 1) The number of responses per format (stereo-pair) was increased from three to nine by utilizing all ten available rows with a response asked on each of the nine different pairs of adjacent rows.
- 2) The number of columns utilized was increased from eight to ten with a corresponding increase of 25% in the disparity range of the test.
- 3) A set of six different disc size x disparity formats was developed (the preliminary test had only one). These formats provide for six responses to each of the nine row/disc-size combinations for a total of 54 responses over the set (see Figure 5).

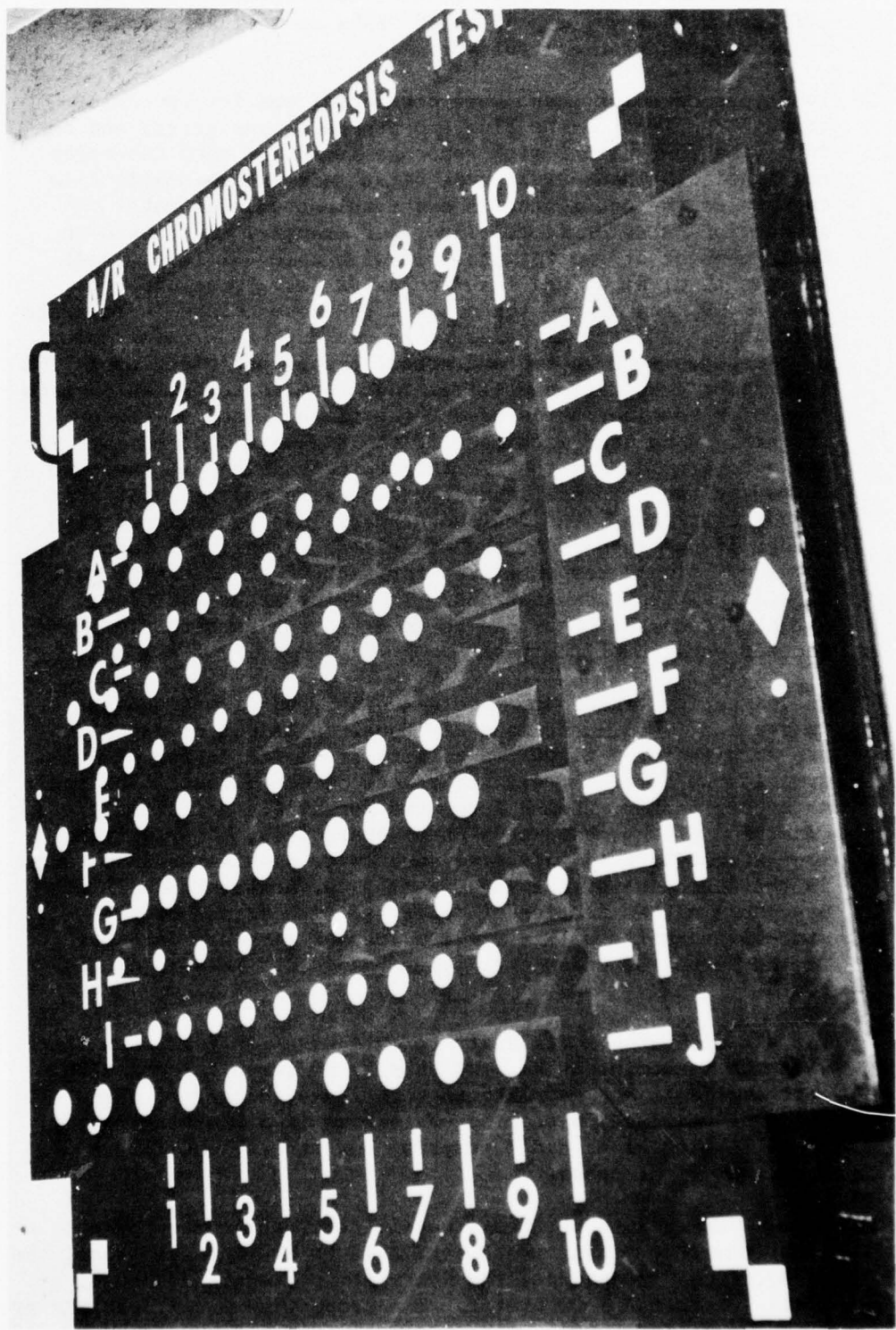

FIGURE 5. MODEL FOR ARC TEST OF CHROMOSTEREOPSIS

- 4) The disc size x disparity formats were photographed as masks on Kodalith achromatic film so that each format could be utilized with a variety of color masks as well as provide an achromatic test control set.
- 5) Two types of color masks were developed; one for two-color comparisons (red versus blue and orange versus green) and one involving four colors with response items for each two-color combination. These masks were first made on achromatic film to provide the configuration and combinations for later reproduction on color film. Thus, for example, the two-color masks consist of two formats, one with color #1 (e.g., red) in rows A, C, E, G, and I and color #2 (e.g., blue) in rows B, D, F, H, and J, and the other with these colors in reversed locations. Additional color masks could be made using color combinations such as red and green, orange and blue, etc. The four-color combination utilizes four formats across which each two-color combination is used three times. Each of these formats can be used with each of the six size x disparity masks to provide a set of 24 formats containing 216 response items, or two response items for each size pair x color pair of adjacent rows. The four color masks can be utilized with either of two subsets of the six size x disparity formats to provide a single response item for each of the 108 size pair x color pair row combinations. The color masks are constructed such that they can be inverted and used to provide another version of the test.
- 6) The disparity cross-over points (column number where discs in vertically adjacent rows are equal in height or depth) are such that the first two formats are suitable for administration to all observers regardless of the direction of their chromostereopsis. Using these two formats to determine the direction of the observer's chromostereopsis, the remaining four formats are administered such as to provide maximum range in the direction of the individual's chromostereopsis. This procedure allows testing of observers with large chromostereopsis shifts with a minimum loss of response data due to the perceived cross-over point being "off the end of the row."
- 7) The six disc size x disparity formats were designed such that, with the two-color masks, two subsets of three formats each were available and complete in themselves, either of which could be utilized in testing where time is a limiting factor. Thus, formats A, C, and E comprise one subset, and formats B, D, and F the other.
- 8) The ARC or refined chromostereopsis test can be used in at least the three instruments available to the investigators, the AO/Wottring Troposcope, the Sonne Strip Viewer and the long focal length Badal Optometer. The respective magnifications are 1.23, 0.714 and 0.666, with column-to-column disparity steps of 48, 28, and 26 seconds of arc for the "24" series test.

Calculation of Disparity in the ARC Series

The dimensions and formulae given in Appendix I, figures I-1, I-2, I-3, can be combined into a single formula for the expression of the disc-to-disc disparity used in the testing for any particular instrument. This can be expressed as:

$$\eta = \frac{206265(A) (\delta) (M)}{10 (U) (R_1) (R_2)}$$

- where: η = Stereo disparity in arc seconds
- 206265 = Constant of conversion from radians to arc seconds
- A = Stereo base in original photographic reduction
(11.09 in. for 24 series)
- δ = Difference in physical height of adjacent discs in
same row (.2 in.)
- M = Magnification of viewing instrument (1.23 for
Troposcope)
- U = Object distance from first nodal point of the lens
in original photographic reduction (149.719 inches)
- R_1 = Reduction factor in original photographic reduction
(8 x)
- R_2 = Reduction factor in subsequent photographic reduction
(1.9437)
- 10 = Constant of convention for viewing distance ratio
(in inches).

Substituting the values used to make the 24 series ARC test, and for viewing in the Wottring Troposcope, we have:

$$\eta_T = \frac{206265 (11.09 \text{ inches}) (.2 \text{ inches}) (1.23) \text{ arc seconds}}{10 \text{ inches} (149.719 \text{ inches}) (8) (1.9437)}$$

$$\eta_T = 24.171 \text{ arc seconds}$$

For viewing in the Sonne Strip Film Viewer, the disc-to-disc disparity would be

$$\eta_S = \frac{24.171 (.714)}{(1.23)} = 14.03 \text{ arc seconds}$$

And, if the Badal is used for viewing these same formats, the disc-to-disc disparity would be:

$$\eta_B = \frac{24.171 (.666)}{(1.23)} = 13.09 \text{ arc seconds.}$$

These were "aim" values, and were verified by the actual disparity achieved, found by measurement of the quantity "g" in appendix I, figure I-3. This was done on a Mann Comparator with "g" found to be .000934 inches. Using this average "g", the second equation from appendix I, figure I-3 was used to determine the disc-to-disc disparity actually attained:

$$\eta = \frac{206265 (.000934) (1.23)}{10} = 23.7 \text{ arc seconds}$$

Testing Procedure and Scoring with the ARC Series

The six formats of the ARC Test were given to a sample of 12 observers, first utilizing the size x disparity masks as an achromatic series, and secondly, using these masks in combination with the red/blue color masks as a chromatic series. The principal objective in this administration was to determine the capability and reliability of the ARC series as a quantitative test of chromostereopsis. Formats A and B, with true crossover points balanced around the center of the formats, were given to obtain an indication of the individual's direction of chromostereopsis. One of these had the red/blue mask oriented so that row A was red, the other so that row A was blue. Since the remaining four formats have their true crossover points skewed toward one side or the other from the center of the row, it was necessary to follow one of two procedures in order to gain maximum available disparity range in the direction of each individual's chromostereopsis:

- 1) The four formats could be presented with the red/blue color mask oriented in the same position for each format (for example, with red always in row A), with the disc size x disparity masks then presented either in normal or reversed stereo, as appropriate in order that for any individual, his shift due to chromostereopsis would be toward the side of the format where, on the average, the greater range is available; or
- 2) The disc size x disparity masks could all be presented in regular stereo, with the red/blue color mask oriented (red on top or blue on top) so as to achieve the same objective of having the maximum range available for each individual's chromostereoscopic shift. The latter procedure was selected as the most appropriate as it avoided potential complications of normal vs. reversed stereo and also resulted in a balance of color mask orientation.

Appendix II, figure II-1, depicts the response data sheet for formats A and B. Across the top are the response steps to either side of the true

crossover point, with each row pairing shown down the left hand edge. For each row pairing, the column numbers (either a column number or a location halfway between two columns were acceptable responses) are represented in relation to the true crossover point. Thus, for example, for format A, row pairing A/B, the response that indicates no shift from the true crossover point is "between columns #4 and #5," while in row pairing B/C, the zero-shift response would be "column #8." The experimenter records the response of the observer (the perceived crossover point) for each of the nine row pairings in each format, and then sums the response step magnitudes as indicated across the top, to obtain a net score (in response steps) and direction of response from zero or the true crossover point. The following equation can be applied to quantify the shift due to chromostereopsis on each format:

$$CS_{\text{FORMAT}} = \frac{(NS)(\eta)(2_A)}{(2_B)(9)}$$

where: NS = the net response step score

η = the disc-to-disc disparity (~24 arc sec. in troposcope for the "24" series)

2_A = constant for conversion from disc-to-disc disparity to column-to-column row-pair disparity

2_B = constant for conversion from response step to column step interval (2 response steps = 1 column step)

9 = constant to average shift over 9 row pairings.

The direction (red advancing or blue advancing) of the CS shift for each format is determined by considering the design of the ramp function and orientation of the color mask for each format. For formats A, B, E and F, the discs in row A get higher (closer) from column #1 to #10, while in formats C and D the reverse is true. Thus, if the red/blue color mask is oriented so that red is in row A on format A, any response shift to the right of the true crossover point will be indicative of a "blue advancing" individual.

Prior to administration of the ARC series, the IPD of each observer was carefully measured using the clinical method and the Troposcope adjusted to a corresponding IPD setting.¹ The ARC series characteristics were described to the observer as they pertained to his task, and a physical model of the alternating ramp configuration was used to clarify this concept. The six formats were administered as an achromatic (baseline) series, followed by the same masks combined with the red/blue color mask as the chromostereopsis-sensitive series.

¹ During the ARC Test administration phase, the Badal instrument was perfected to the point where the IBX distance could be measured for some of the observers, and this was used rather than IPD for these observers.

THE DEVELOPMENT OF A PARAFOVEAL SCAN CHROMOSTEREOPSIS TEST

Foveal vs. Parafoveal Chromostereopsis

This development was the first of a kind in trying to measure the amount of chromostereopsis between a central (foveal) figure and a parafoveal comparative stimulus of two different hues; it had as a secondary purpose the development of a survey test for chromostereopsis. As such, this test development was a continuation of the development of the precision chromostereopsis test.

Recent data obtained by optical refraction off-axis from the fovea indicated that for many individuals, the parafoveal refractive correction is of greater spherical value than the on-axis (i.e., line-of-sight) correction. It was reasoned then, that a parafoveal chromostereopsis test might provide different results from those of a test where the comparative stimuli are proximal to each other and near the fovea. As an example, the individual with an elongated posterior chamber of the eye would require a greater minus correction on-axis. The longer vitreous chamber would be associated with a non-spherical orb, an asymmetry where the distance from the second nodal point of the eye to the retina would be longer on-axis than in the parafovea. The anatomical condition of a long vitreous chamber could result in a blue parafoveal stimulus appearing in focus when the fovea is simultaneously stimulated by red rays. This follows from the fact that chromatic aberration of the eye bends the short wavelengths to form a focus nearer the second nodal point of the lens of the eye than for the long wavelengths. The hue of the stimulus could thus, in part, correct for the differential distance between the lens and the light sensitive surface of the retina under these conditions. If the hues were interchanged as to position, the red falling in the parafovea and the blue on the fovea, the differential focal length and the chromatic aberration would then be additive rather than compensatory. The perceptual result might be that one of the hues would appear out of focus and have a differential apparent size and brightness. Thus, a parafoveal chromostereopsis test might provide additional information if its design compares foveal and parafoveal targets of different hues. This concept was incorporated in the development of the parafoveal scan chromostereopsis test. Three forms of this test have been developed, and the characteristics of Form II, the form used in the preliminary investigations, include:

- 1) The central figure is a solid disc, the diameter falling within the range of 51 to 60 minutes of visual angle. The disc, then, covers the rod free area of the fovea but does not exceed the foveal diameter. (Actual measurement of stimuli = 59.85 min. of arc.)
- 2) The parafoveal comparative stimuli are 12 concentric circles of decreasing diameter and decreasing width as they recede in stereoscopic distance from the observer. The largest circle has an outside diameter of 8.88° , and a stroke width of 14 arc min. The recession of each of the remaining rings is at 21.6 sec. of arc of disparity. The width of the clear circles

(white or chromatic) decreases at each interval by 5.46 min. of arc. The 12th and smallest circle has an inside diameter of $1^{\circ} 22'$ of arc. The total displacement between the 12 rings is nearly 240° arc seconds. Ring 6 has very narrow breaks at 90° and 270° to assist in counting the rings (see table 2).

- 3) The pattern for these formats was made up on a coordinatograph machine at 16x the final copy size. The original pattern was copied on the Borrowdale camera in a one-step reduction of 15.45x. Three pairs of stereograms were made where the relative displacement (reading direction) of the central disc to the outside ring was respectively 145, 79.2 and 67.6 arc seconds and these were designated as Peripheral Scan Test Stereo Pairs #1, #2, and #3, respectively.
- 4) Three sets were made of the three pairs of stereograms. The first set, on Kodalith film, was used as the achromatic set. The second and third sets were made on Eastman Ektachrome Professional color film. The second set had a blue central disc and red peripheral concentric circles. The third set had a red central disc and blue concentric circles.
- 5) The task for the observer was to report the number of the ring which appeared co-planar with the central disc. The largest diameter (and "nearest") ring was "number one." Responses designating between-ring positions were also allowed.
- 6) The results could be utilized in two ways: (a) in determining the magnitude of the perceived displacement from the actual physical displacement in the stereoscopic pair; and (b) as a difference score representing the combined chromatic scores less the value obtained with the achromatic set. The second method was utilized as it allowed for a "subtracting out" of any marked perceptual stereoscopic bias that affected achromatic and chromatic presentations alike.

Parafoveal Scan Test Procedure

The test material consisted of:

- 1) An achromatic set of three stereotransparency pairs made on Kodalith film with a dark field and clear disc and peripheral rings.

Stereo transparency
pair #1 - Disc with 145 arc sec. disparity relative
to outer ring

#2 - 80 arc sec.

#3 - 70 arc sec.

TABLE 2. DIMENSIONS AND DISPLACEMENTS OF THE DISC AND RINGS
 IN THE PERIPHERAL SCAN CHROMOSTEREOPSIS TEST
 AS VIEWED IN THE A.O. TROSCOPE OR AT
 A MAGNIFICATION OF 1.23

CENTRAL DISC

SET NO.	DISC DIAMETER ARC MINUTES	DISC DISPLACEMENT (ARC SEC.)		
		ACHROMATIC	BLUE FIELD	RED FIELD
1	59.85	146	138	134
2	59.85	80	85	83
3	59.85	68	70	70

PERIPHERAL RINGS

<u>RING NUMBER</u>	<u>INSIDE DIAMETER</u>	<u>WIDTH OF RING</u>	<u>DISPLACEMENT</u>
1	8.47 Degrees	14.2 arc min.	0.0 arc seconds
2	7.72	13.6	21.6
3	7.00	13.1	43.3
4	6.29	15.6	64.9
5	5.60	12.0	86.6
6	4.93	11.5	108.0
7	4.28	10.9	129.6
8	3.66	10.4	151.2
9	3.06	9.8	172.8
10	2.47	9.3	194.4
11	1.91	8.7	216.0
12	1.36	8.2	237.6

- 2) A chromatic set of three stereotransparency pairs made on Ektachrome film with a dark field, red disc and blue peripheral rings. The stereo pairs had similar relative disc displacements.
- 3) A chromatic set of three stereotransparency pairs made on Ektachrome film with a dark field, blue disc and red peripheral rings. The stereo pairs had similar relative displacements of the disc (see table 2).

These nine stereotransparency pairs were mounted on 3.25 x 4 x .06 inch aluminum plates which have a centered circular aperture of 60mm diameter through which the images are translighted.

The display equipment may be either the Badal Optometer, the Sonne Viewer, or the American Optical Wottring Troposcope (Model 13300). The following procedures apply to the Troposcope, and the dimensions given in table 2 correspond to the 1.23 magnification of this instrument. This instrument's lenses have a focal length of 207 millimeters, and when the transparencies are at this distance from the lenses, an infinity focus display results. This is generally associated in theory with relaxed visual accommodation (distant focus of the eyes).

The tungsten illumination sources were filtered with Wratten Number 78 filters to give the illuminance a color approximating 5500K. The color transparencies were balanced for this illuminance color.

The instrument was set up for the best match of the interocular centers with the individual's IBXD. In the absence of this measurement, the IPD was used. Initially, the individual was shown one of the chromatic stereotransparencies and asked to judge whether the red and blue hues appeared equally "sharp," "clear," or "in focus." If the blue image was not "clear," minus spherical trial lenses were added before the eye in increasing order of power until the observer gained an apparent match as to "sharpness" of the images. All presentations were then made with this correction in the instrument's trial lens receptacles. The "arms" of the Troposcope were generally set at 2° of convergence to assist the observer in gaining and keeping "third degree fusion."

The nine stereoscopic pairs were presented in the following order: Trials 1 through 3 were the three achromatic targets; Trials 4 through 9 were a random presentation of the chromatic stereotransparencies.

The instructions to the observer were: "You are asked to judge the perceived distance from your eyes of the central disc relative to the 12 rings. The rings are the lighted circles, and in the case of the color transparencies, illuminated and colored. Report the ring number which matches the apparent distance of the disc. Think of a plane perpendicular to your line of sight which would pass through the disc and through one or between two rings. Report the ring number that appears co-planar or equal distant with the disc. Ring number 1 is the largest in diameter and closest to you. Looking into the tunnel of concentric rings, number 6 has two narrow breaks on either side (at 90° and 270°),

and number 12 is the smallest in diameter and width and also furthest away from you. Your impression will be that this is difficult to judge accurately; however, go ahead and make your best apparent match. Our data indicate that you will do better than you think!"

The data score sheet is illustrated in Appendix III-1. In the top (achromatic) group, if the observer indicates that the disc matches ring 8, the "+6" is circled in row one if he is looking at stereopair #1, +71 if looking at pair #2, and +83 if it is pair #3. A typical pattern of responses was "ring 8" for pair #1, "ring 5" for pair #2, and "ring 4" for pair #3. This achromatic score would be the average of 6, 7, and 8 arc seconds, i.e., 7. Since all the scores are to the right of the zero line (the heavy divider line), the average score of 7 would be equivalent of 7 arc seconds with the disc perceived further forward than its true position relative to the rings. Responses which are mixed, for example one to the left of zero and one to the right, are averaged algebraically, the experimenter keeping track of the average being for disc forward or back. The "+" and "-" are used in a different context with the color stimuli, however. With the color stimuli, "+" implies that the long wavelength hue (red, orange) is seen as advancing or nearer than short wavelengths (blue and green). Therefore, the plus scores are on the left of zero for the blue field (or blue rings) set and to the right of zero on the red field set. The average score for these independent color sets is obtained in the same manner as the achromatic, keeping the algebraic signs.

Chromostereopsis was measured with a difference score: the chromatic displacements as they differ from the achromatic. The individual's chromostereopsis estimate is the average of the six difference scores in arc seconds. After completing the nine trials, the experimenter would ask of the observer if he noted any shift in the apparent focus of the central disc when it was red compared to when it was blue. This question was always delayed until after the estimations of matching distances were complete.

For any individual performance, there are four scores: achromatic average perceptual displacement, blue field chromatic average displacement, red field average displacement, and the chromostereopsis score (or the chromatic, both fields/achromatic correction difference score), all in arc seconds.

GENERAL PROCEDURE IN EVALUATIONS

In the preliminary examination of some procedures and techniques, two or three individuals were given a large number of trials. An example was in the attempt to determine if day-to-day differences in IBXD measures were due to individual variability or to drifts in the alignment of the optical equipment. These endeavors were treated as preliminary experiments, and the data were used to improve equipment and procedures.

In evaluating the two chromostereopsis tests, a selected sample of eleven individuals was employed. This group was selected to gain homogeneity regarding two parameters. First, a group with exceptional skill in achromatic stereoscopic acuity was desired. This objective was attained,

as these eleven people had a range of stereoscopic thresholds from less than 6 seconds of arc to 16 seconds, with a mean of 7 seconds and a standard deviation of 3.25. Secondly, it was desirable to have a group skilled in making visual perceptual judgements in behavioral experiments. All of the observers had some such experience. Two had only a few prior experiences, but nine had from 6 to 38 years of working with behavioral science techniques. This group was given the two chromostereopsis tests, repetitions of the Critical Limen Stereo Test (CLST) achromatic and chromatic forms, and had IPD measurements taken. Five of these individuals also participated in the measurements of IBXD, pupil size, interpupillary distance, and interiris distance.

This smaller group participated in the development cycles and preparatory experiments. Specific subroutines in the procedures will be mentioned in the next section, as the preliminary data are discussed; to avoid repetition, it will not be included here.

SECTION IV
RESULTS AND DISCUSSION

THE INTER-BEHAVIORAL AXES MEASUREMENT

The success with the main task of developing a precision test for chromostereopsis and studying its relationship to visual performance was very dependent upon the accurate positioning of the eyes relative to the emerging rays of the binocular instrument.

There is no external signpost by which we may directly locate the position on the cornea where an entering ray of light will pass through the nodal point of the lens and the center of the fovea. However, this is the definition of the visual, or behavioral, axis of the eye, and an extension of this line also passes through the object fixated in the visual world. Entering rays of chromatic luminance are laterally displaced when the physical axis, the center of the effective pupil, the perpendicularity of the lens, or any combination of these, are not proximal to the visual axis. Therefore, if we place a small concentrated bundle of rays at the temporal edge of the natural pupil, we impose a lateral chromatic aberration in the eye. When two ray bundles, one composed of long wavelengths and the second of short wavelengths, are introduced off axis, they are laterally displaced to two different positions on the retina. If the same two ray bundles enter the second eye, also on the temporal side of the natural pupil, a mirror image of the lateral displacement occurs for the second eye. The combined effect is the perception that the different hues emanate from two different positions in space, a "chromostereopsis," due to where the rays of light enter the eyes. Individual variability in the direction and amount of this chromostereoscopic effect is due to the unique contribution from the individual's own physiological set of eye axes and angles. Therefore, the better the measurement of the separation of the visual axes for any individual, for each accommodation distance, and the more exact application of this distance, the greater the precision of measuring individual chromostereopsis.

Five methods of measuring the "distance between the eyes" were examined in some detail. Three had high estimates of reliability in the preliminary research, and two of these were obtained with the long focal length Badal Optometer. The five methods were:

- 1) The Conventional Clinical Method
- 2) The Narrow-Aperture Adjustment Method
- 3) The Intermirror Adjustment Method (Badal)
- 4) The Corneal Reflection Method (Badal)
- 5) The Distance Between the Same Edges of the Irises Method (Badal)

Seven observers were asked to provide three replications of each of the five types of measurement of their IPD's. These observers ranged between 60mm and 68mm in their IPD measurements, or roughly $\pm 1\sigma$ of the USAF population about a mean of 63.3mm.

The Narrow-Aperture Adjustment Method

The narrow-aperture adjustment method used a cardboard occluder with a 1mm wide x 4mm high slot for each eye. The left eye slot was fixed and the right eye slot was on an adjustable slide. This black occluder was held just in front of the eyes of the observer. The fixation target was a vertical black line 45 feet away, and the observer was instructed to center this line in the aperture before each eye. Then, the distance between the slots was measured with a metric caliper to the nearest tenth of a millimeter. Three trials were completed by each of the seven observers.

The Intermirror Adjustment Method

The observer was seated before the mirrors of the Badal Optometer. Crosshair reticles were placed at optical infinity and back-lighted with the light sources. At a near-point position, about 18mm from the lenses, an inverted cone was placed along the optical center of each beam. The observer was asked to position his right eye so that the tip of the cone and the vertical line were aligned. Then, maintaining that alignment, he adjusted the left mirror until the left hand crosshair and cone point were aligned. When the observer was satisfied with his adjustment, the distance between the centers of the mirrors was measured to the nearest 0.1mm.

The Corneal Reflection Method

When the observer had completed the mirror adjustment method, the corneal reflections were photographed on Type 52 Polaroid film. The reflections were of the Badal lenses as back-lighted by the illumination sources. The distance between right and left edges of the reflections was measured for both reflections, and the centers calculated using a Mann comparator with intervals of .001 millimeter. A trigonometric correction was applied for the radius of curvature of the cornea and the distance to the camera lens. Initial calibration and copying size ratios were obtained against two steel spheres of 7.125mm radius to simulate the 7.1mm radius of the corneal curvature of the schematic eye.

The Distance Between Similar Edges of the Irises Method

The same photographs were measured to determine if the IPD could be determined by measuring the edges of the iris and calculating the centers and the inter-centers distance. The edges of the irises are much easier to judge than the low contrast edges of the pupils against the dark irises.

Comparison of "IPD" Measurement Methods

In the preliminary investigation, the narrow aperture, inter mirror and corneal reflection methods gave estimates of reliability above .95 (contrasted with .72 for the clinical method).

The narrow aperture technique was not followed extensively as a question of validity is raised by the presence of the narrow apertures. These are effectively small artificial pupils and, therefore, may improve depth of field of the eye and also impose diffraction limits.

The theoretically most promising method was the inter-mirror distance, since it required the observer to align two objects in the visual field and therefore utilized an operational definition of the visual axis. This method is referred to as the Interbehavioral Axes Distance (IBXD) method in this report. Important in obtaining this measurement was (a) very precise location of the eye (cornea) to mirror distance, and (b) a steady head rest (bite board).

A more extensive investigation of this method used three observers, with ten trials per observer, and 400 ft.c of illuminance. The results are presented in table 3.

TABLE 3. RELIABILITY OF THE IBXD METHOD ON THE BADAL

<u>OBSERVER</u>	<u>MEAN IBX</u>	<u>σ</u>	<u>σ^2</u>
CDA	67.456mm	.086	.007396
CLK	63.895mm	.1802	.032472
DFM	66.54mm	.994	.988036

ESTIMATE OF RELIABILITY = $\frac{\sigma_s^2}{\sigma_s^2 + \sigma_e^2} = \frac{3.4029}{3.4195} = .995$

Most of the variability in measurements, at this point, was found to be attributable to the Badal Equipment. It appeared that further improvement could be attained by a more stable bite plate, a more stable optical bench, and micrometer stages for the adjustment of the reticles used in optical alignment.

The Effects of Alignment Error Using Artificial Pupils

The narrow-aperture stereoscopy as studied by Vos (1960) showed that shifting these narrow apertures had a very pronounced effect on the relative perceived distance to red and blue stimuli. Owens and Leibowitz

(1974), using 1mm and 2mm artificial pupils, confirmed Vos' position. The Owens and Leibowitz study used a viewing distance of 2.5 meters and vertical slits (12.5 x 2.5 arc min.) translighted and filtered as red (W. #29) and blue (W. #47) to a photopic luminance of approximately 80 ft.L. Mean changes were found of 3.0 and 2.7 min. of arc/mm of decentering for the 1 and 2 millimeter pupils, respectively. The larger error with the smaller pupil is also consistent with Vos' position. Mattas (1974) has used the Howard-Dolman apparatus to determine where 2mm artificial pupils should be placed to neutralize an individual's chromostereopsis. With the "neutral IPD" and with minus lenses to compensate for differential focus of hues, she tested her subjects in a Wottring Troposcope. Using the CLST, she reports improved performance with the chromatic test, which approximated the achromatic performance, using the "neutral IPD" over that attained with a conventional IPD setting. Her 16 subjects had exceptional stereoscopic skill with achromatic stimuli, and although their performance was lower with the chromatic stimuli and "neutral IPD" setting, the difference was not statistically significant. The performance on the chromatic CLST with conventional (Titmus) IPD setting was statistically poorer than that with the achromatic stimuli.

In the current investigation, the authors were interested in the effects of artificial pupil positioning on the estimated distance of red and blue stimuli. Two observers were tested as to their perception of the relative distance between red and blue in the ARC Test when 2mm artificial pupils were placed before the natural pupils. The artificial pupils were 11 and 16mm from the two observers' corneas and 16.5mm from the lenses in the Troposcope. Each observer was tested with at least ten different separations of the artificial pupils, at intervals of 0.3mm, within the range provided by the limits of the natural pupil. Format B of the ARC chromostereopsis test was used as the visual test material with the red/blue color filters used to modulate the hues of the ramps under comparison. At each artificial pupil setting, the observer reported the apparent distance match for each of the row pair comparisons. The individual data points in figure 6 are the average of the nine discriminations across the format, and represent the average perceived displacement of the crossover point from its true location.

A suggestion by D. F. McKechnie led to the preparation and study of the effects of artificial pupil decentering on an achromatic set of the ARC test as well. This suggestion was followed to provide a comparative control condition and a source of data on the problem of perceptual discontinuities which occurred in the preliminary version of the test. Each observer viewed the "Format B" stereoscopic pair, without the chromatic filter, under two separations of the artificial pupils (2.0mm for CK and 2.5mm for CA), just within the maximum range of separations used in the chromatic investigation. With the achromatic stimuli, the artificial pupils imposed 9.3 and 3.2 arc second shifts per millimeter for these two observers, respectfully. In figure 6 these small changes obtained with the separation of the artificial pupils appear as almost horizontal lines, approximating no deviation from the true crossover points. The average value is 17 times smaller than that obtained with the red and blue ramps. These data imply that decentered artificial pupils, or decentered exit pupils in an instrument, are not an important variable for achromatic stimuli.

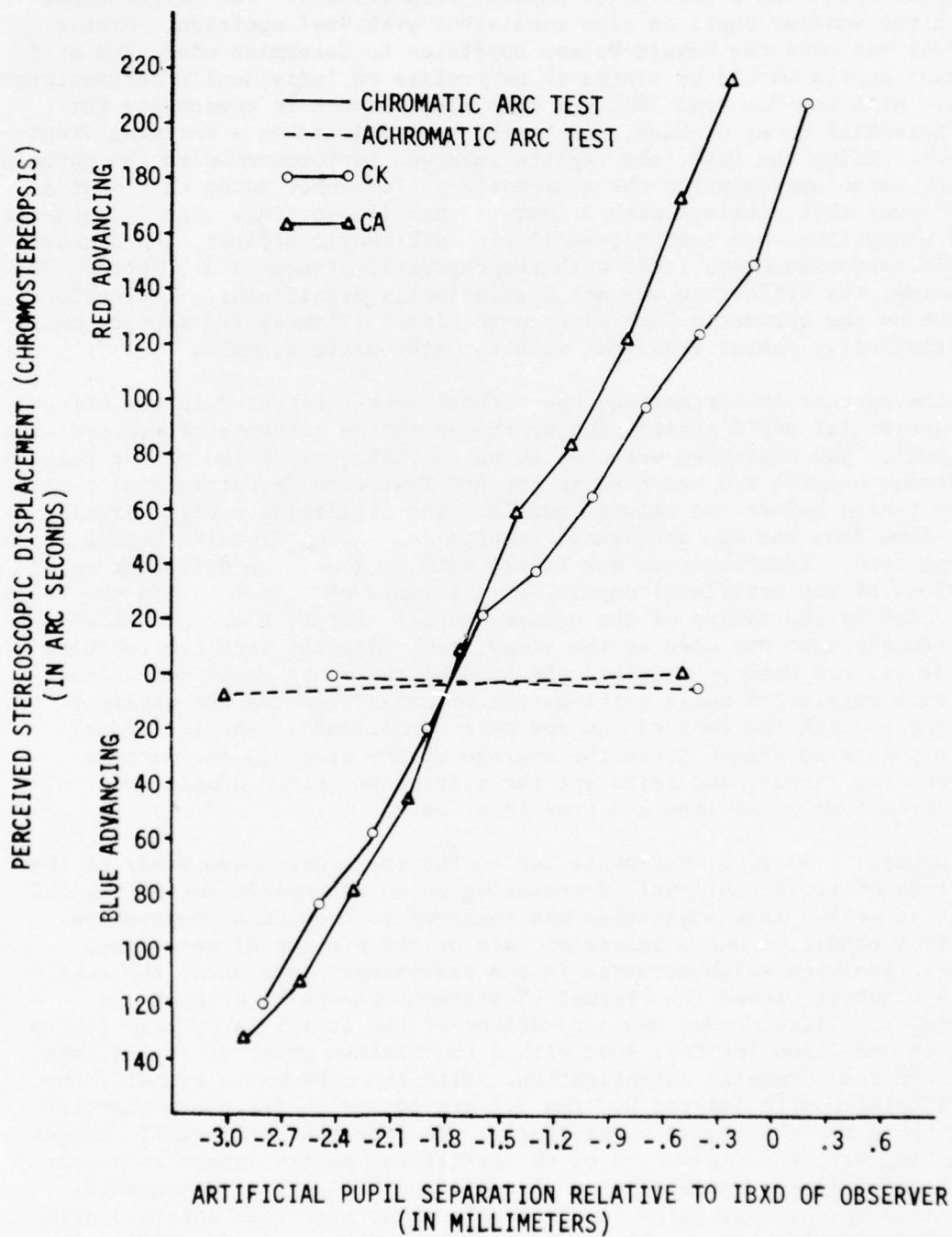

FIGURE 6. THE EFFECT ON CHROMOSTEREOPSIS OF DECENTERING 2 MM ARTIFICIAL PUPILS

For chromatic stimuli, however, the positioning of artificial or exit pupils is an important variable in stereoscopic discrimination. The above data average 106.7 arc seconds/mm for CK and 127.8 arc seconds/mm for CA. With red appearing in front of blue when the artificial pupils are decentered temporally from the visual axes. These values are less than those obtained by Owens and Leibowitz (1975) for 2mm diameter pupils (162 arc seconds/mm), but the direction is the same and agrees with previous investigators. The difference of about 25% may be due to different amounts of chromostereopsis, etc.; or the difference may be the result of differences in the experimental conditions, such as the distance from the artificial pupils to the corneas of the observers in the two investigations. In any case, both sources of data indicate that artificial pupils significantly effect the spatial location of colors in the frontal plane.

The Physiological-Optical Correlates

With the more precise control and measurement of the inter-behavioral axes distance, a preliminary study was undertaken to see if any measurable correlates existed among IBXD, the distance between the centers of the pupils, and the distance between the reflections of the entering rays of light. The IBXD is assumed to be equivalent to the distance between the visual axis of each eye when the measurement refers to the frontal parallel plane just anterior to the first surface of the cornea and measured when the visual axes are parallel. The term "interbehavioral axes distance" (IBXD) is a specific intervisual axes distance requiring two separate and optically remote fixation points separated by a distance equivalent to the IBXD. The interpupillary and inter-reflection distances must be determined from the calculated centers of the pupils and reflections. The data are from repeated measures of the distance between inside and outside edges of the pupils and reflections, as this technique reduces the error due to differential size of the reflection and/or pupil in either eye. The sizes of the pupils and reflections among five observers are to be found in table 4a, and a test of significance of the differences in table 4b.

If the effect of decentering artificial pupils from the visual axes generalizes to the natural pupil's locations, we would predict that if the center of the natural pupil was on the nasal side of the behavioral axis for each eye this person would see blue as near. A variation of this theory would predict blue appearing nearer with the center of the Styles-Crawford Maxima on the nasal side of the behavioral axes. With the improved instrumentation, our preliminary data are inconclusive as the results from only three of our five observers agree with these theories.

Table 5 gives the empirical values obtained with the Badal and the long focal length camera. In figure 7, these values are graphed as normalized on the behavioral axis along the abscissa. The ordinal values are the proportion of use of long wave colors as answers in the chromatic CLST. Other data indicate that as the red-near perception increases, the frequency of use of red as an answer correlates highly with the amount of chromostereopsis (Kraft and Anderson 1973). The two extreme individuals in figure 7 approximate the hypothesis. The two individuals with 15.6 and 6.2 arc seconds of chromostereopsis use approximately 45% red answers and so also fit the hypothesis. The fifth individual should have a slight red bias in his answers from the hypothesis.

TABLE 4a. REFLECTION AND PUPIL SIZES IN BADAL
DURING INVESTIGATIONS OF IBXD METHODS

<u>OBSERVER</u>	<u>PUPIL SIZE</u>	<u>MEAN REFLECTION SIZE</u>	<u>REFLECTION SIZE α</u>
1 SJB	3.1052 mm	.7415 mm	.0411 mm
2 CDA	3.174	.8504	.0624
3 RJF	3.912	.9504	.0256
4 CLK	3.021	1.0381	.0745
5 RCB	3.175	.7811	.0229
SPHERES (7.125 mm)		.9975	

TABLE 4b. TESTS OF SIGNIFICANCE FOR
DIFFERENCES IN REFLECTION SIZE

(Values are t_s)

<u>Ss</u>	<u>1</u>	<u>2</u>	<u>3</u>	<u>4</u>
2	4.1			
3	11.0	4.6		
4	9.9	5.9	3.4	
5	1.9	2.2	15.4	10.0

$t_{.01} = 3.2$

TABLE 5. RELATIONSHIPS AMONG IBXD, CENTERS OF PUPILS, AND
CENTERS OF ENTERING LUMINANCE RAYS

INTEROCULAR DISTANCE (CENTER TO CENTER)

<u>Ss</u>	<u>IBXD</u>	<u>INTER- PUPIL DISTANCE</u>	<u>INTER- REFLECTION DISTANCE</u>
1 SJB	66.9	65.680	66.227
2 CDA	67.3	67.324	67.268
3 RJF	63.9	63.487	64.204
4 CLK	63.9	63.864	63.829
5 RCB	64.63	64.537	64.801

MEAN DISTANCE FROM BEHAVIORAL (VISUAL) AXIS
(Positive values indicate locations temporal to behavioral axis)

<u>Ss</u>	<u>PUPIL</u>	<u>REFLECTION</u>	<u>Σ ALGEBRAIC</u>
1 SJB	-1.220	-0.673	-1.893
2 CDA	+0.024	-0.032	-0.008
3 RJF	-0.413	+0.304	-0.109
4 CLK	-0.036	-0.071	-0.107
5 RCB	-0.093	+0.171	+0.078

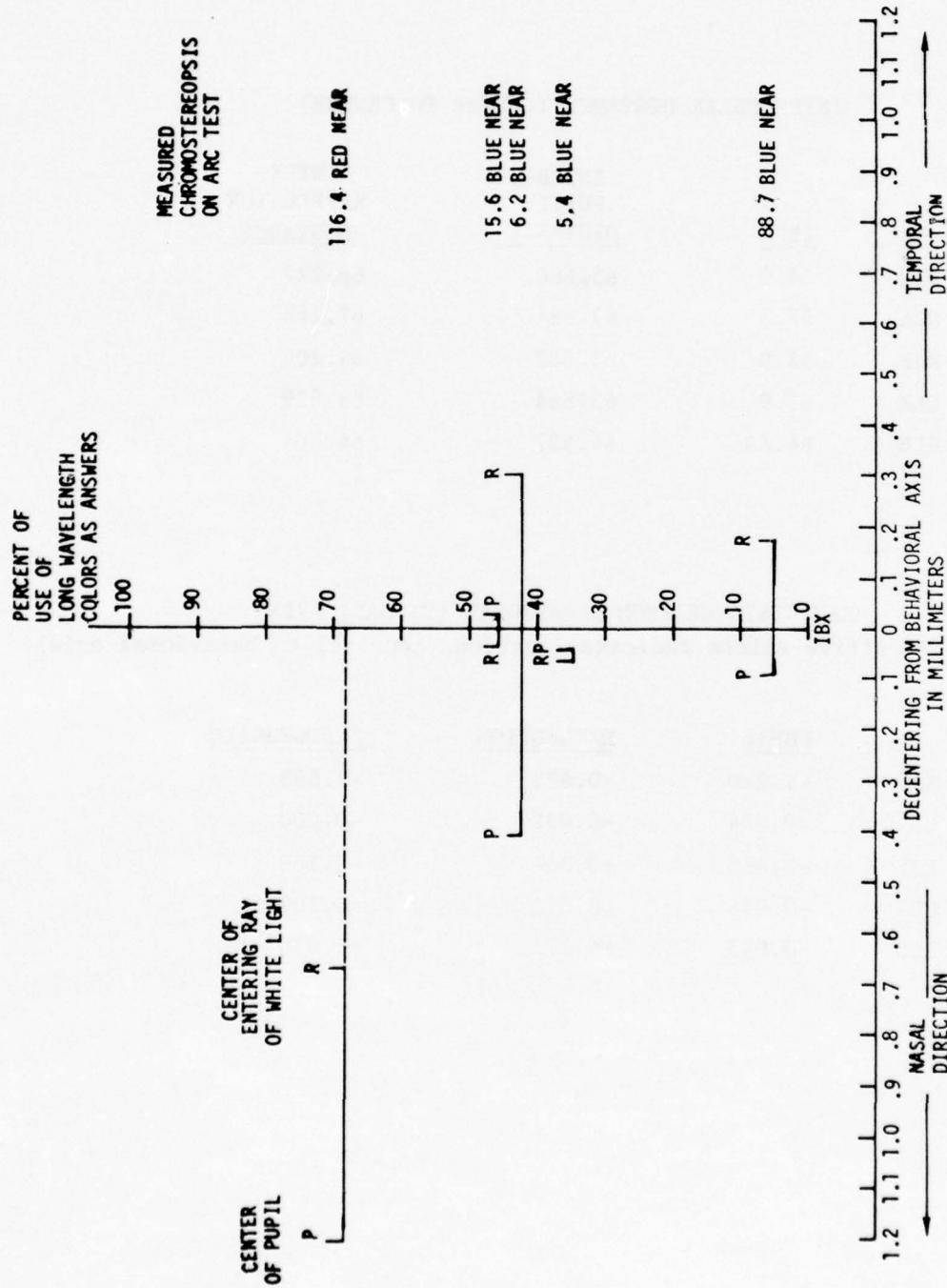

FIGURE 7. FREQUENCY OF USE OF LONGWAVELENGTH COLORS AS "NEAR" ANSWERS AS RELATED TO DEVIATIONS OF NATURAL PUPILS AND REFLECTIONS RELATIVE TO BEHAVIORAL AXES FOR FIVE OBSERVERS

However, his 35% use of red indicates a slight blue-near chromostereopsis, and the ARC test indicates he has a 5.4 blue-near chromostereopsis.

These results are thought-provoking and appear to be worth extending into a larger scale study. The greatest limitation to these data was a variable distance between the eye and the camera permitted by the flexion of the bite board. A better camera mount and new stainless steel bite plates should reduce the variance of these measures.

The Parafoveal Scan Test Results

The evaluation included administering the PSCT to the twelve individuals with the exceptional achromatic stereo skill (average threshold 7.3 arc sec., $s = 3.25$ arc sec.). Most individuals remarked that it was a difficult perceptual judgement to make. However, the general results indicate that they performed better than they expected.

The chromatic minus achromatic scoring on the PSCT was used to compare the results with the ARC test, CLST performance, and to predict use of hues as answers in the CLST. The PSCT gives very similar relationships to that of the ARC test in ranking the 12 individuals as to their chromostereopsis. There are five transpositions in rank among these 12 people. The correlation between the two tests is $+0.906$ (Table 6). In absolute magnitudes, the ARC test assigns larger chromostereopsis scores to people near the extremes of the distribution. However, the thresholds are not statistically different.

In addition to this high degree of correspondence with the longer and more precise ARC test, the PSCT performance correlates $.80$ with the total proportion of long wavelength responses in the chromatic stereoscopic test. The coefficient of forecasting efficiency will be greater than 50% for this correlation. Comparatively, the ARC test does predict the proportion of long wavelength responses to a higher degree ($r = .91$). The hue response statistic is based on the frequency of use of the orange and red hues as answers to which disc is nearest. This frequency of use of orange and red increases as a function of the direction and amount of chromostereopsis with which the individual has to contend. If all reds are displaced toward him by his chromostereopsis, a greater real stereoscopic displacement of a green or blue disc must exist to make the short wavelength colors appear nearer. If the red-near chromostereopsis exceeds the largest actual disc displacement in the test, then all his answers should be red. The individual with a large amount of blue-near chromostereopsis would, therefore, infrequently use red as an answer. This hypothesis is supported by these correlations, and figure 8 introduced with the discussion of the ARC test illustrates how this function works.

In addition to this good prediction of chromostereopsis, the PSCT results gave some additional information. As the colors interchanged between the central disc and the parafoveal rings, several things were noted: (1) the effect is different for each individual, with a range that is equal to 30 times the smallest individual shift; (2) that each color in the periphery has an equal chance of inducing the comparatively larger change; (3) the magnitude of the shift for 11 of the 12 observers is

TABLE 6. CORRELATIONS BETWEEN PERFORMANCE ON SCAN AND ARC TESTS OF CHROMOSTEREOPSIS AND THE FREQUENCY OF USE OF LONG WAVELENGTH HUES AS ANSWERS ON THE CHROMATIC CLST

<u>OBSERVER</u>	<u>SCAN TEST*</u> (AVE. SCORE)	<u>ARC TEST*</u> (Δ SCORE)	<u>LONG WAVELENGTH</u> <u>RESPONSE ON CLST</u> (% OF TOTAL)
SB	47.6	116.4	74
DM	40.8	74.7	78
ES	11.6	64.4	84
JG	17.3	43.1	66
RAB	13.7	28.9	57
GG	2.7	11.5	72
CK	- 11.5	- 5.4	37
RF	19.0	- 6.2	42
CA	- 8.0	- 15.6	45
PF	- 13.4	- 37.8	33
RS	- 85.2	- 80.4	23
RCB	- 52.8	- 89.8	6

* Scores in ARC Seconds - Blue Advancing as Negative

CORRELATIONS

	<u>SCAN</u>	<u>ARC</u>
<u>ARC</u>	.906	-
<u>CLST</u>	.805	.916

TEST OF SIGNIFICANCE BETWEEN SCAN AND ARC TESTS OF CHROMOSTEREOPSIS

$$\bar{X}_{\text{SCAN}} = -1.52 \quad \sigma_{\text{SCAN}} = 35.7$$

$$\bar{X}_{\text{ARC}} = 8.65 \quad \sigma_{\text{ARC}} = 58.8$$

σ OF CORRELATIONS

	<u>SCAN</u>	<u>ARC</u>
<u>ARC</u>	.054	-
<u>CLST</u>	.106	.048

$$t = 1.11$$

$$t_{.05} = 3.11$$

larger than that individual's achromatic threshold; (4) the perceptual phenomenon operates independently of the magnitude and direction of chromostereopsis. Correlations between this difference in effect of hue, performance and/or physiological aspects of the eye have not as yet been established.

Although the rings begin in the parafovea and extend outward only to 9° , the procedure of reversing foveal color and parafoveal color has a large stereoscopic effect. This particular design of the stimulus does not allow vernier acuity to play as significant a role as would be the case where vertical edges may be directly compared. In addition, any stereoscopic effect from torsional rotation of the eyes is excluded by the circular design.

If chromostereopsis was the total influencing factor one would expect the central disc to be displaced an equal amount (but opposite in direction) when the field colors are reversed. However, in table 7, the displacements are shown to be unequal by values of 16 to 150 seconds. It is hypothesized that such lack of symmetry is possibly due to a non-spherical shape of the eye. This hypothesis assumes that among individuals the distance from the second nodal point of the eye to the fovea ranges from equal to longer than that to the parafovea at 5° off axis. When the blue hue is represented along the shorter distance of the 2nd nodal point to the parafovea, the effective focus is better than when red is used to illuminate the field. The chromatic interval corrects, at least in part, for the blue luminance, for this shorter distance, and imposes greater dispersion of the red rays when red is used in the field position. This hypothesis requires checking by: (1) a measurement of the length of the eye at the fovea, and at 5° and 10° off axis to correlate with these data; or (2) a measure of accommodative change as red and blue are alternated between the fovea and parafovea stimuli.

The Precision Chromostereopsis Test (ARC) Results

This development had as its principal objective the design and evaluation of a precision test of chromostereopsis. The secondary goal of a rapid survey test was conceived as a fractional use of the six pairs of stereotransparancies. This discussion will begin with the predictive capability of the test. The difference score (chromatic minus achromatic) gives an excellent prediction of the percent of long wavelength hues used as answers in the CLST. The correlation of .916 has a standard error of .05. In effect, then, as this test measures chromostereopsis from a blue-near direction of large magnitude, through a minimum chromostereopsis, and then to a large amount of red-near chromostereopsis, the proportion of use of long wavelength colors increases in the color stereoscopic acuity test. The values are to be found in table 6 and are depicted in figure 8.

The existence of chromostereopsis may be considered as an attenuator of stereoscopic skill with chromatic imagery. For example, if an individual had 30 seconds of chromostereopsis, regardless of direction, then he should only be able to attain a chromatic stereoscopic discrimination which is 17.9 seconds larger than his achromatic threshold.

TABLE 7. DIFFERENCE SCORES BETWEEN RED-FIELD AND BLUE-FIELD
PERIPHERAL SCAN CHROMOSTEREOPSIS TESTS

OBSERVER	DISC DISPLACEMENT BETWEEN RED- AND BLUE- FIELD SERIES* (ARC SECONDS)	FIELD WITH LARGER EFFECT**	P.S.C.T. CHROMOSTEREOPSIS SCORE (ARC SECONDS)
JG	150	Blue**	19R
ES	134	Red	13R
PF	80	Blue	14B
SB	76	Red	48R
RAB	75	Blue	14R
GG	59	Blue	3B
RS	52	Blue	85B
RF	41	Red	19R
DM	35	Red	50R
CA	31	Blue	8B
RCB	16	Red	53B
CK	17	Blue	12B

* Disc's location in space as a function of reversing hues of disc (foveal) and rings (peripheral).

** When red field imposes more perceptual shift than blue field (from the disc's location as perceived on the achromatic series), this column contains a red designator.

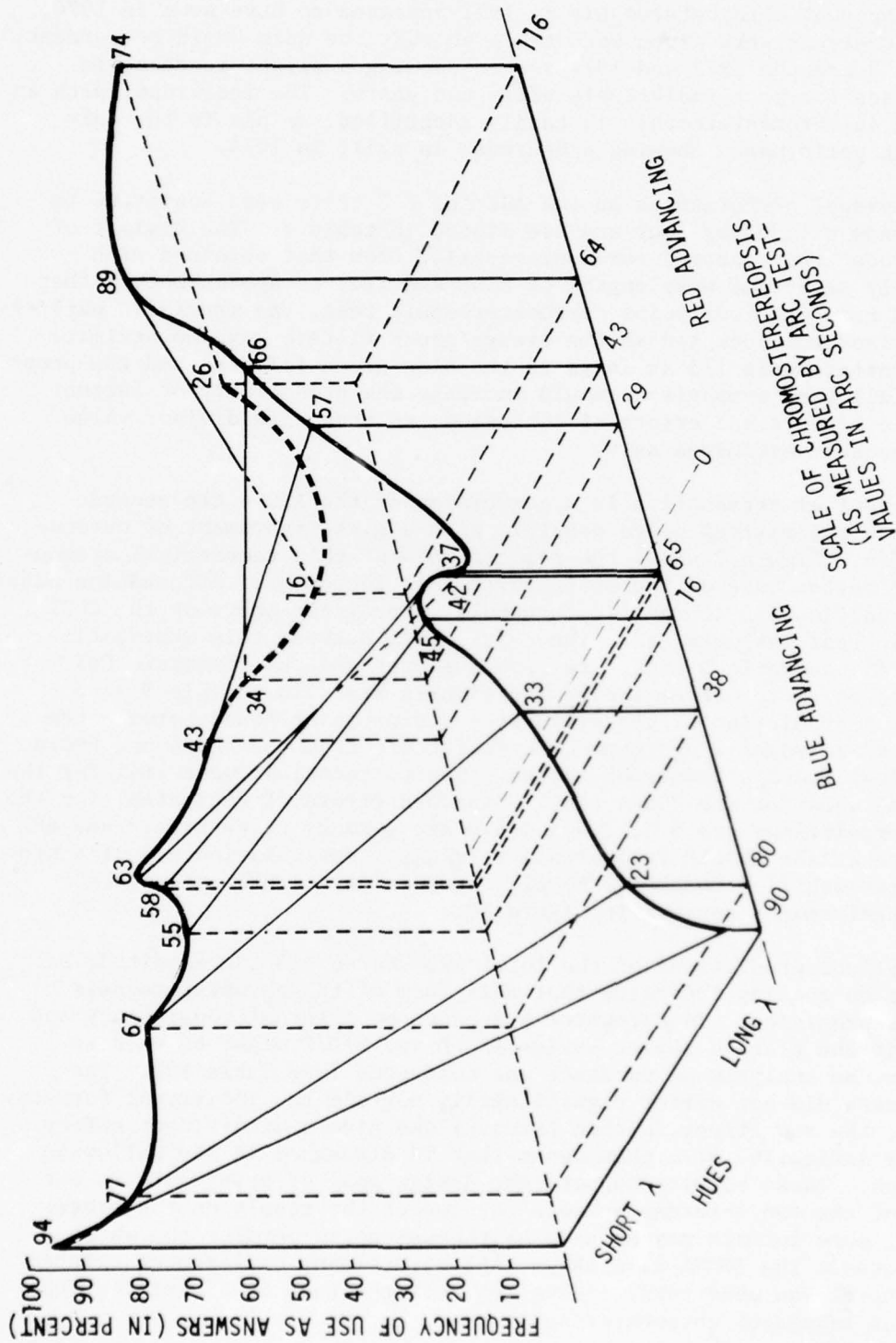

FIGURE 8. THE PROPORTION OF USE OF LONG AND SHORT WAVELENGTH COLORS IN THE CHROMATIC STEREOSCOPIC TEST AS A FUNCTION OF CHROMOSTEREOPSIS FOR TEN OBSERVERS

This concept was tested by using the homogenously stereoscopically skilled sample and measuring their performance on the two CLST tests, achromatic and chromatic. Seven of the individuals had previously served as observers (Kraft, Booth and Boucek, 1972). However, one observer who had no apparent chromostereopsis in 1972 appeared to have some in 1974, so all observers were given both tests so that the data would be current. In table 8 are the 1972 and 1974 scores showing a slight increase in performance for most individuals after two years. The individual with an increase in chromostereopsis is easily identified, as his is the only chromatic performance showing a decrease in skill in 1974.

The individual performances on the ARC and PSC tests were converted to arc seconds divided by four and are listed in table 7. The divisor of four reduced the measured chromostereopsis, from that obtained with the widely separated wavelengths of blue and red, to approximately that expected from the four color chromostereopsis test. As mentioned earlier this divisor was accepted as the orange/green filters gave an estimate of chromostereopsis 1/3 as large as the blue/green filters, and the presence of all four comparisons would increase the probability of further chromatic effects and errors of confusion, so that this divisor value was reasonably estimated as 4.

The theoretical attenuation is a conversion of the ARC/4 arc second score into the maximum score possible with a given increment of chromostereopsis. Figure 9 shows the relationship of this theoretical attenuation of performance on the CLST. With this incremental attenuation added to the individual's achromatic threshold a predicted score on the CLST chromatic test was obtained. The correlation between this achromatic plus ARC/5 theoretical model arc second scores and the chromatic CLST threshold value for these twelve individuals was .714. Table 9 also includes a prediction of the difference scores to be found between the observers' achromatic and chromatic CLST tests from the ARC/4 and PSC/4 theoretical model attenuation scores. The correlations were .641 for the ARC/4 and .384 for the PSC/4 test. Standard errors of estimates, for the above correlations are 5.5, 3.9 and 4.0 arc seconds respectively and 68% of future trials should fall within $\pm 1\sigma_{est}$. The relationship of achromatic stereoskill + chromostereopsis attenuation to chromatic stereoscopic performance appears in figure 10.

The excellent predictions of the total use scores and the magnitude of attenuation scaling indicated that this form of the chromostereopsis test was promising. To determine a measure of internal consistency and to see if the planned subset series A/C/D vs. B/D/F might be used as subtests, an analysis of variance was completed (see Table 10). The two subsets did not differ significantly, nor did the individual formats. However, the row effect (within formats) did give a significant effect. This was indicative of a phenomenon that is discussed in the following paragraph. These results support the design goal of being able to use either of the two 3-format subsets to predict the result on the other. Further, some formats may be used by themselves to predict the whole test scores. The ANOVA also shows that significant differences existed among the eleven observers, indicating that the test is discriminating different levels of chromostereopsis.

TABLE 8. TEST-RETEST RELIABILITY OF CLST SCORES WITH TWO YEAR INTERVAL BETWEEN TESTS

ACHROMATIC CLST SCORES (TOTAL NUMBER CORRECT)		CHROMATIC CLST SCORES (TOTAL NUMBER CORRECT)	
<u>1972</u>	<u>1974</u>	<u>1972</u>	<u>1974</u>
52	57	31	35
34	48	22	34
48	47	44	40
50	57	40	50
55	57	44	50
40	37	25	31
46	45	34	38
Mean - 46.4	49.7	34.3	39.7
σ - 6.72	7.11	8.19	7.02
r -	+ .69		+ .81
σ_r -	.215		.136

TABLE 9. PREDICTION OF STEREOSCOPIC SKILL WITH
CHROMATIC IMAGERY FROM CHROMOSTEREOPSIS AND ACHROMATIC
SKILL

OBSERVER	SCORES ON CHROMOSTEREOPSIS TESTS (IN ARC SEC.)		THEORETICAL MODEL OF CLST ATTENUATION		ACHROMATIC THRESHOLD + ARC CHROMOSTEREOPSIS ATTENUATION
	ARC	PSC	MODEL	PSC	
	<u>4</u>	<u>4</u>	<u>ARC</u> <u>4</u>	<u>4</u>	
SB	29.1R	12.1R	17.9	10.6	22.9
DM	18.7R	12.5R	19.6	14.0	32.6
ES	16.1R	3.2R	11.8	7.5	17.8
JG	10.8R	4.8R	10.8	8.5	17.8
RAB	7.2R	3.4R	9.5	7.6	15.5
GG	2.9R	1.0B	7.5	1.6	15.1
CK	1.3B	2.9B	6.6	7.4	11.6
RF	1.5B	4.8R	6.7	8.5	11.7
CA	3.9B	2.0B	7.7	7.1	12.7
PF	9.4B	3.4B	16.5	14.3	32.8
RS	20.1B	21.3B	20.1	20.5	32.5
RCB	22.4B	14.2B	17.8	11.4	22.8

	CLST ACHROMATIC THRESHOLDS (ARC SEC.)	CLST CHROMATIC THRESHOLDS (ARC SEC.)	CLST DIFFERENCE SCORE ACH-CHROM.(ARC SEC.)
	SB	5.0	21.5
DM	13.0	20.1	7.1
ES	6.0	25.3	19.3
JG	7.0	20.8	13.8
RAB	6.0	13.7	7.7
GG	7.6	13.9	6.3
CK	5.0	8.6	3.6
RF	5.0	6.0	1.0
CA	5.0	7.1	2.1
PF	16.3	36.5	20.2
RS	12.4	29.5	17.1
RCB	5.0	42.9	37.9

PREDICTIONS: ACHROMATIC THRESHOLD + ARC MODEL ATTENUATION TO
CHROMATIC STEREOSCOPIC THRESHOLD IN ARC SEC.

$$r = .714 \quad \sigma_r = .148$$

ARC MODEL ATTENUATION TO ACHROMATIC-CHROMATIC CLST
THRESHOLD DIFFERENCE.

$$r = .641 \quad \sigma_r = .178$$

PSC MODEL ATTENUATION TO ACHROMATIC - CHROMATIC
CLST THRESHOLD.

$$r = .384 \quad \sigma_r = .257$$

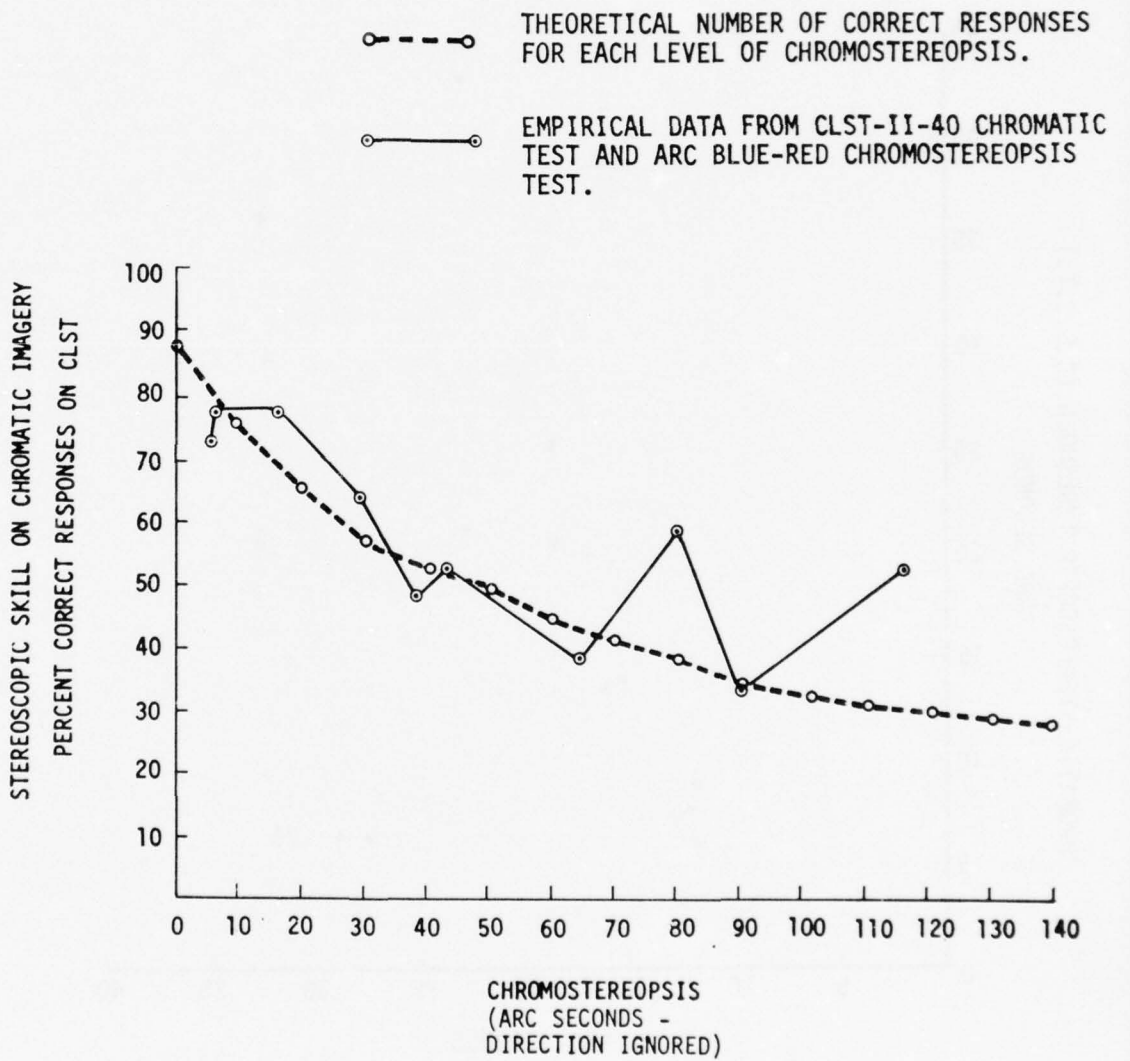

FIGURE 9. STEREOSCOPIC SKILL ATTENUATION AS A FUNCTION OF CHROMOSTEREOPSIS

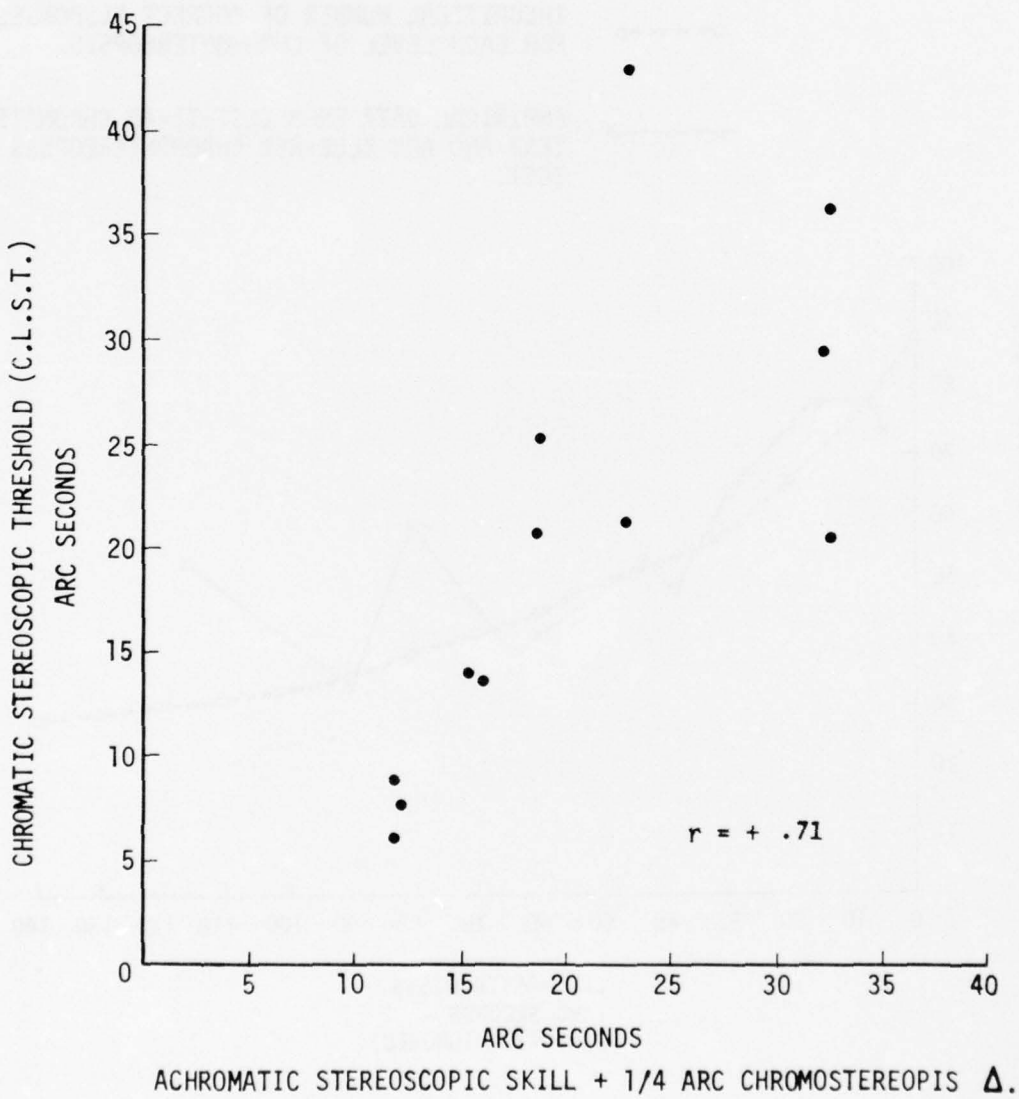

FIGURE 10. PREDICTION OF STEREOSCOPIC SKILL WITH CHROMATIC IMAGERY BY KNOWING CHROMOSTEREOPSIS AND ACHROMATIC STEREOSCOPIC SKILL

TABLE 10. ANALYSIS OF VARIANCE FOR ACHROMATIC-CHROMATIC
DIFFERENCE SCORES ON THE ARC TEST

ANOVA*

<u>SOURCE</u>	<u>df</u>	<u>SS</u>	<u>MS</u>	<u>F</u>	<u>ERROR TERM</u>
Groups of Formats	1	.56	.56	.81	GS
Subjects	11	1407.72	127.97	113.80**	RS (FG)
Formats (Groups)	4	7.25	1.81	1.32	SF (G)
Groups x Subjects	11	7.57	.69	.61	RS (FG)
Rows (Formats x Groups)	48	103.52	2.16	1.92**	RS (FG)
Subjects x Formats (Groups)	44	60.30	1.37	1.22	RS (FG)
Subjects x Rows (Formats x Groups)	528	539.75	1.12		
TOTAL	647	2126.67	135.68		

* Values are in response steps representing achromatic-chromatic difference scores - one response step equals 24 arc seconds of disparity.

** Significant at $\alpha = .01$

TABLES OF MEANS

FORMATS WITHIN GROUPS

<u>FORMAT</u>	<u>MEAN</u>	<u>FORMAT</u>	<u>MEAN</u>
A -	1.94	B -	1.90
C -	2.11	D -	2.04
E -	1.80	F -	2.09
A/C/E AVE. =	1.95	B/D/F AVE. =	2.01

FORMATS X ODD VS. EVEN ROW PAIRINGS

<u>FORMAT</u>	<u>MEANS (ODD ROW PAIRS)</u>	<u>MEANS (EVEN ROW PAIRS)</u>
A	2.13	1.69
B	1.90	1.89
C	2.37	1.79
D	1.68	2.48
E	1.42	2.29
F	2.35	1.77

The Analysis of an Unusual Response Pattern

It was almost immediately apparent in recording the responses on the ARC series (both achromatic and chromatic) that a curious pattern of responses was occurring. This exhibited itself with the achromatic series as a rhythm of responses on the data sheet which alternated from one side of the zero or crossover point to the other. Figure 11 depicts this phenomenon for observer #1 for both the achromatic and chromatic series of format B. This effect was consistent across formats (see figure 12) and the same for all but one of the observers. In an attempt to isolate the variable responsible for this phenomenon, the achromatic series was presented in reversed stereo, upside down, and even with the Troposcope upside down, along with various combinations of these conditions. No physical, mechanical or perceptual basis could be found for this anomaly, however. The single consistency in all viewing conditions was that, in responding to a pair of rows, the observer consistently gave crossover points which would be appropriate if the top row he was observing was perceived as further back in relation to the bottom row (a "layback" effect) than was in fact the case. Since in each subsequent pairing, the ramp slant reverses for the rows, this produced the alternating sequence of responses. Because of the alternating shift, and because it occurred also with the chromatic series, it was decided that the best measure of the chromostereoscopic shift for each row pairing would be the difference between the achromatic shift and the chromatic shift. This is the mode of response upon which the predictions, discussed earlier, were based.

Each observer, as he proceeded through both the achromatic and chromatic test, evidenced the systematic response pattern. It was so consistent that the experimenters found themselves predicting the next response, often in magnitude, and almost always in direction. This did not affect the chromatic-achromatic difference scores as a measure of chromostereopsis, since the response pattern was very similar in direction (differed only in magnitude) for both forms of the test (see figure 11). Correlations were run to study five possible factors which were felt might be responsible, either alone or in some combination, for the observed response pattern. These included:

- 1) "Layback Effect": A pair of horizontal ramps is responded to as though the rows are spatially displaced relative to each other (top row back; bottom row forward). Very consistent for any individual.
- 2) "C.T.D.": Central Tendency in Direction. Response shift is made toward the center of format.
- 3) "C.T.Q.": Central Tendency Quantified by including number of steps from the center of the matched discs.
- 4) "S.S.D.": Sequential Shift, Directional. The shift is away from the just previous response.

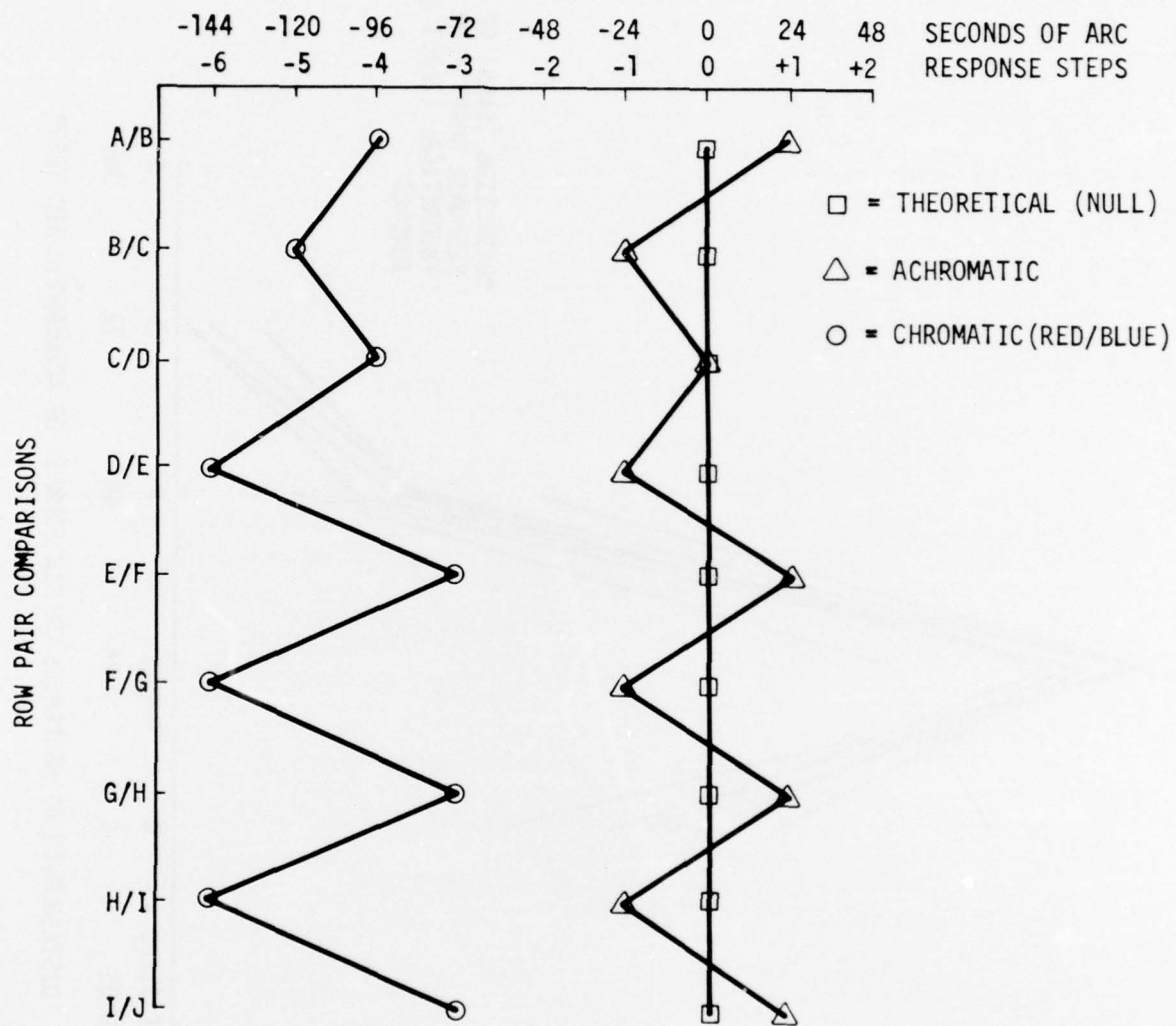

FIGURE 11. RESPONSE DISTRIBUTION BY ROW PAIRS FOR OBSERVER #1 ON ACHROMATIC AND CHROMATIC VERSIONS OF FORMAT B OF ARC TEST

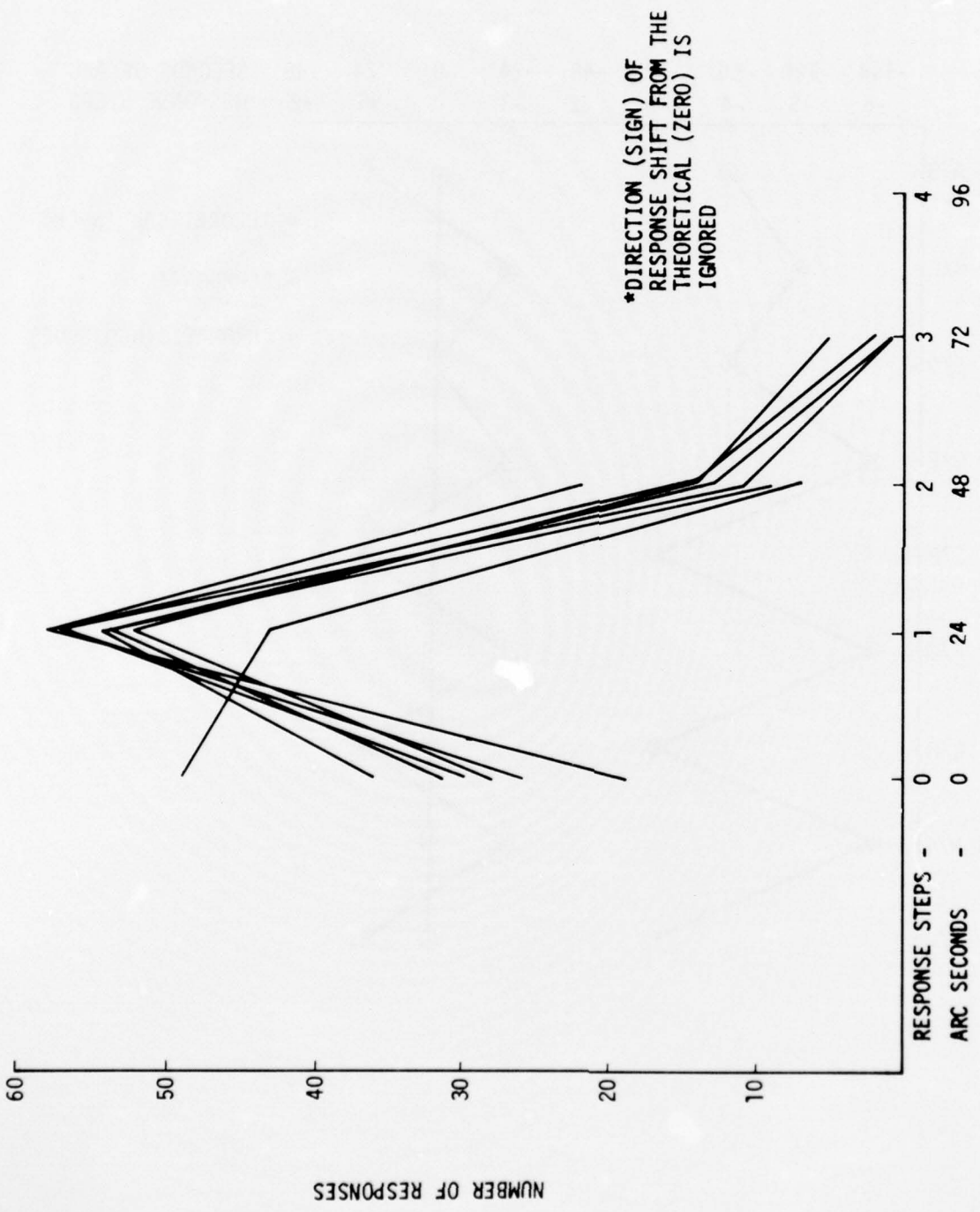

FIGURE 12. DISTRIBUTION OF RESPONSES ON SIX FORMATS OF ACHROMATIC ARC TEST*

5) "S.S.Q.":

Sequential Shift, Quantified by the number of steps.

These five factors are represented in the top portion of the correlation matrix reproduced as table 11. The "layback" effect has the highest average correlation, with an $\bar{X}_r = .65$, compared with averages for CTD, CTG, SSD, and SSQ of .28, .26, .24, and .29 respectively. The correlations for the layback effect vary from .04 to .88, while those for the other four factors range from .00 to .62. Inspection of the table reveals that individuals with relatively low correlations on the "layback" factors have relatively higher correlations on the other factors and vice versa. This shows some promise of a multiple correlation prediction that will serve as a more complete explanation of this response pattern. Combining the "layback" factor with each of the other factors did indeed raise these correlations, although no combination was clearly better than another. Resolution of the cause of this intriguing response pattern shall have to await further investigation.

TABLE 11. CORRELATION MATRIX AMONG THE
 FIVE FACTORS WHICH MAY CONTRIBUTE TO
 THE RHYTHMIC "LAYBACK" RESPONSE PATTERN

	<u>LAYBACK</u>	<u>CTD</u>	<u>CTG</u>	<u>SSD</u>	<u>SSQ</u>
S ₁	.84	.06	.02	.02	.04
S ₂	.04	.62	.55	.57	.62
S ₃	.84	.27	.21	.16	.26
S ₄	.35	.41	.43	.27	.35
S ₅	.76	.35	.37	.20	.31
S ₆	.45	.52	.48	.45	.53
S ₇	.64	.34	.32	.34	.37
S ₈	.83	.08	.08	.01	.10
S ₉	.88	.08	.05	.00	.07
S ₁₀	.54	.44	.44	.62	.60
S ₁₁	.83	.02	.02	.08	.10
S ₁₂	.79	.21	.20	.10	.20

	<u>LAYBACK/ CTD</u>	<u>LAYBACK/ CTQ</u>	<u>LAYBACK/ SSD</u>	<u>LAYBACK/ SSQ</u>
S ₁	.80	.67	.80	.65
S ₂	.31	.38	.31	.49
S ₃	.90	.82	.90	.82
S ₄	.50	.55	.46	.52
S ₅	.85	.85	.83	.79
S ₆	.64	.67	.65	.73
S ₇	.74	.72	.79	.75
S ₈	.81	.73	.81	.68
S ₉	.85	.75	.86	.70
S ₁₀	.30	.16	.23	.05
S ₁₁	.78	.69	.83	.69
S ₁₂	.82	.76	.81	.72

SECTION V
CONCLUSIONS

The laboratory tool of a specialized long focal length Badal Optometer may be used to:

- 1) Measure the distance between the behavioral axes of the eyes at intervals of 0.1mm and with a reliability coefficient of .995.
- 2) Measure the interpupillary distance, pupil size, intercorneal reflection distance and size, and interiris distance and size.
- 3) Study the relationships of these measurements to stereoscopic performance and to foveal and parafoveal chromostereopsis.
- 4) Verify whether the existence of the corneal reflection and pupil both on the temporal or both on the nasal side of the behavioral axis is associated with the direction of chromostereopsis.

A Parafoveal Scan Chromostereopsis Test was developed and evaluated. Performance correlates well with the precision test scores concurrently developed ($r = .91$), predicts responses of individuals in chromatic stereoscopic acuity tests, and may be used as a short screening test.

The PSCT results indicate that interchanging the colors between parafoveal and foveal stimuli does not result in the same spatial perception. Large individual differences were measured among observers with similar and very low thresholds for achromatic stereoscopic displacements. The implications for night formation flying and for night refueling with colored signal lights are of interest.

A precision chromostereopsis test was developed. This test measures individual differences in the range of 5 to 130 seconds of arc. It can be fractionated to be used as a survey test and is very flexible as color filters and pattern masks can be used interchangeably.

The ARC test results predict the frequency of use of long or short wavelength hues as answers in a chromatic stereo test with a correlation of .92. Performance correlates, as an estimate of the attenuation of an individual's achromatic stereoskill with chromatic stereo threshold a coefficient of .714.

The evaluations have disclosed an unusual response pattern that will require further analysis and/or investigation to determine the contributions of several possible factors. The pattern is found with both achromatic and chromatic imagery, and may have a significant impact in tasks involving the stereoscopic discrimination of vertically adjacent stimuli.

APPENDIX I

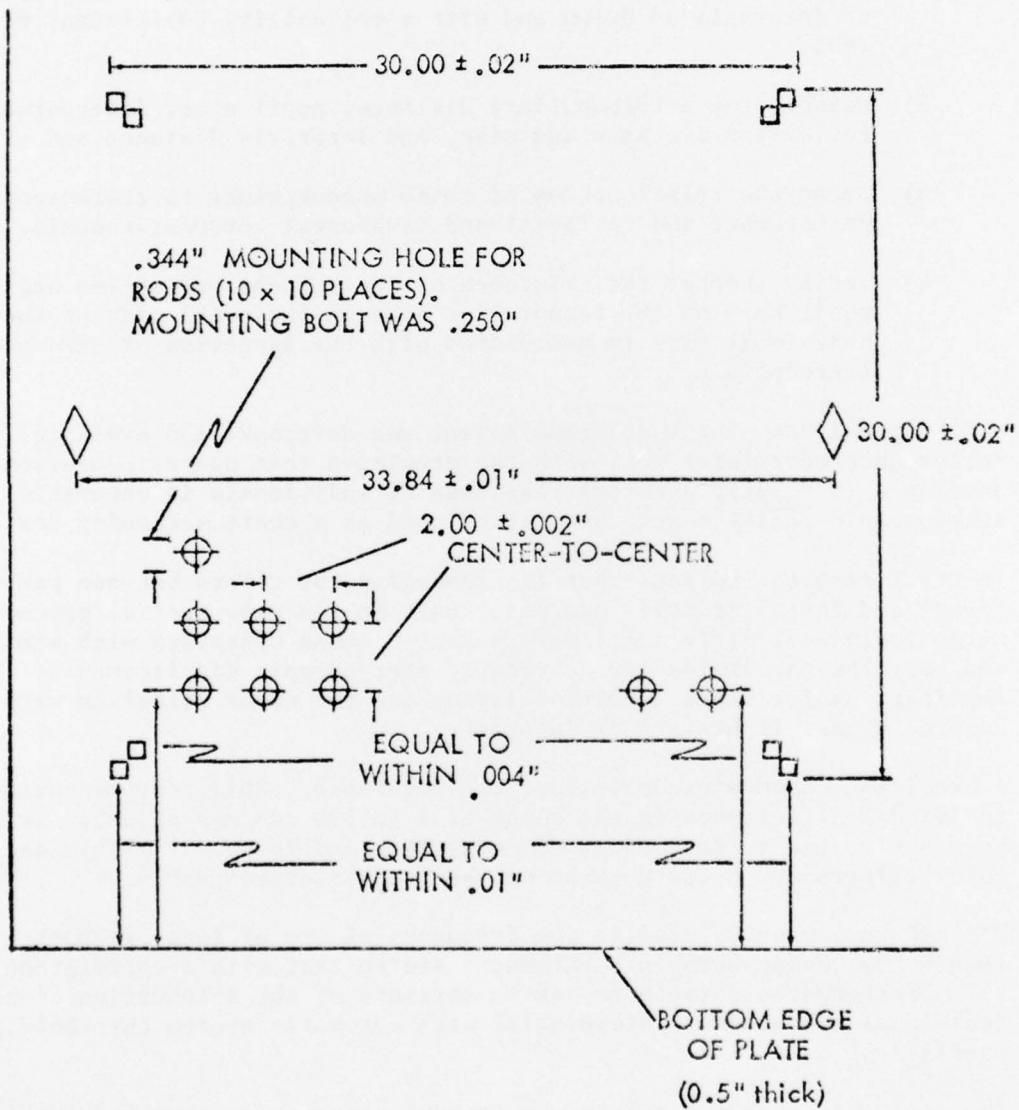
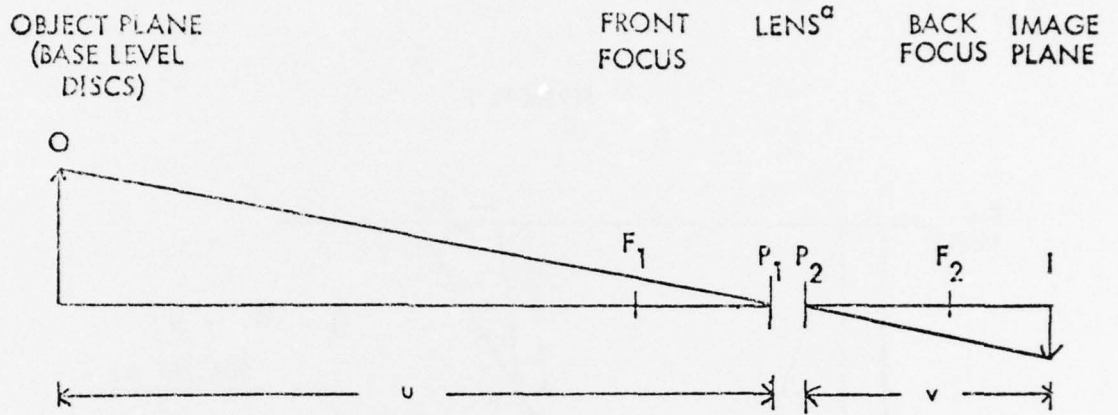

FIGURE I-1. PRIMARY DIMENSIONS ON PHYSICAL MODEL
(Not to scale)

APPENDIX I



PARAMETER	LETTER DESIGNATION	AIM VALUES (inches)	ACTUAL VALUE (inches)	ERROR (percent)
LENS FOCAL LENGTH	F_1P_1 and P_2F_2		16.635	
NODE SEPARATION	P_1P_2		.094	
OBJECT DISTANCE	u	149.719	$149.726 \pm .02$	
IMAGE DISTANCE	v	18.715	$18.720 \pm .01$	
PHOTOGRAPHIC REDUCTION	$R = \frac{u}{v}$	8.000	$7.987 \pm .002$.16 ^b

^aGoerz Artar "red dot," Serial No. 815466, mounted in the Boeing Microelectronics Laboratory Borrowdale Miniaturization Camera

^bThat is, the photographs were .16 percent larger than desired at this stage.

FIGURE I-2. PRINCIPLE DIMENSIONS OF CAMERA SETUP USED TO TAKE STEREO PHOTOGRAPHS

APPENDIX I

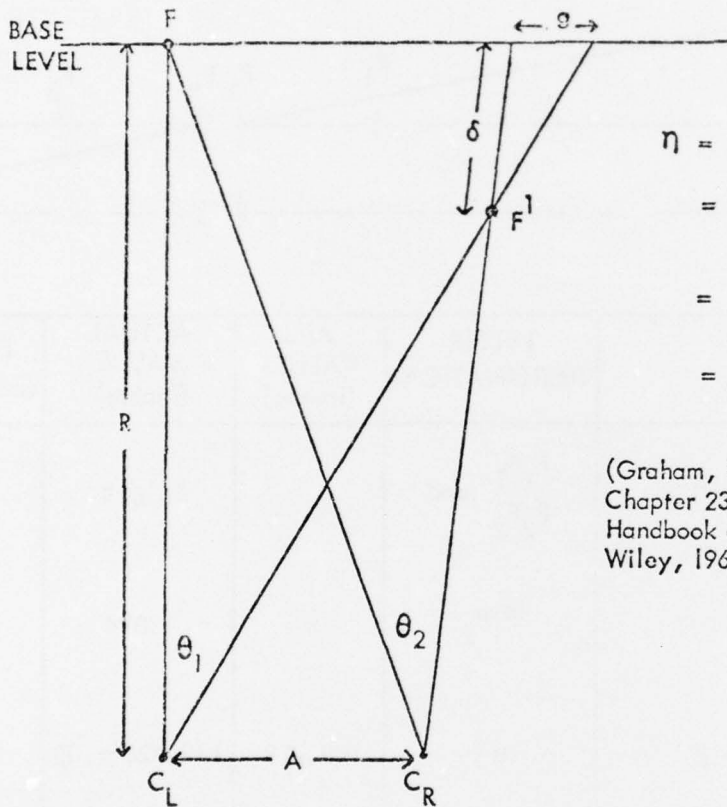

$$\begin{aligned} \eta &= \theta_2 - \theta_1 \\ &= \frac{206,265 A \delta}{R^2} \\ &= \frac{206,265 g}{R} \\ &= \frac{206,265 M g \text{ (Inches)}}{10} \end{aligned}$$

(Graham, C. H., Visual perception, Chapter 23 in Stevens, S. S. (ed.), Handbook of Experimental Psychology, Wiley, 1965).

η = Stereo disparity (in arc seconds)

F = Base level disc

F_1 = Raised Disc

C_L = Left-hand camera station (or eye)

C_R = Right-hand camera station (or eye)

δ = Height of disc above base level

R = Camera (or eye) lens first nodal point distance ($R \gg \delta$)

A = Distance between camera stations or eyes (stereo base)

g = Relative displacement (lateral disparity) of raised disc (in inches)

M = Ratio of angle subtended by object as viewed to angle subtended by object at 10 inches (magnification)

FIGURE I-3. STEREO DISPARITY FORMULAE

APPENDIX II

DATE _____ **FORMAT A** NAME/# _____

	15	14	13	12	11	10	9	8	7	6	5	4	3	2	1	0	1	2	3	4	5	6	7	8	9	10	11	12	13	14	15
A/B									1	2	3	4	5	6	7	8	9	10													
B/C	1	2	3	4	5	6	7	8	9	10																					
C/D										1	2	3	4	5	6	7	8	9	10												
D/E					1	2	3	4	5	6	7	8	9	10																	
E/F			1	2	3	4	5	6	7	8	9	10																			
F/G								1	2	3	4	5	6	7	8	9	10														
G/H					1	2	3	4	5	6	7	8	9	10																	
H/I						1	2	3	4	5	6	7	8	9	10																
I/J		1	2	3	4	5	6	7	8	9	10																				

DISC CHROMA
ORDER _____

⊖ SCORE _____
⊕ SCORE _____

NET SCORE
DIRECTION _____

FORMAT B

	15	14	13	12	11	10	9	8	7	6	5	4	3	2	1	0	1	2	3	4	5	6	7	8	9	10	11	12	13	14	15
A/B				1	2	3	4	5	6	7	8	9	10																		
B/C								1	2	3	4	5	6	7	8	9	10														
C/D					1	2	3	4	5	6	7	8	9	10																	
D/E									1	2	3	4	5	6	7	8	9	10													
E/F							1	2	3	4	5	6	7	8	9	10															
F/G	1	2	3	4	5	6	7	8	9	10																					
G/H										1	2	3	4	5	6	7	8	9	10												
H/I			1	2	3	4	5	6	7	8	9	10																			
				1	2	3	4	5	6	7	8	9	10																		

DISC CHROMA
ORDER _____

⊖ SCORE _____
⊕ SCORE _____

NET SCORE
DIRECTION _____

FIGURE II-1. ARC TEST RESPONSE SHEET

APPENDIX III

ACHROMATIC (WHITE RINGS - WHITE DISC) [MINUS = BLUE ADVANCE]																							
ANVIL	1	1.5	2	2.5	3	3.5	4	4.5	5	5.5	6	6.5	7	7.5	8	8.5	9	9.5	10	10.5	11	11.5	
#1	+138	+127	+116	106	+95	+84	+73	+62	+51	41	+30	+19	+8	-2	-13	-24	-35	-45	-56	-67	-78	-89	-100
#2	+85	+63	+48	+42	+20	+9	-2	-69	-58	-48	-37	-26	-15	-4	+6	+17	+28	+38	+49	+60	+71	+82	+93
#3	+70	+48	-25	-3	+5	-6	-17	+8	+19	17	+28	+34	+50	60	+71	81	+92	103	+114	+125	+136	147	+158
AVE																							
CHROMATIC BLUE FIELD RED DISC [MINUS = BLUE ADVANCE]																							
#1	+138	+127	+116	106	+95	+84	+73	+62	+51	41	+30	+19	+8	-2	-13	-24	-35	-45	-56	-67	-78	-89	-100
#2	+85	+63	+48	+42	+20	+9	-2	-69	-58	-48	-37	-26	-15	-4	+6	+17	+28	+38	+49	+60	+71	+82	+93
#3	+70	+48	-25	-3	+5	-6	-17	+8	+19	17	+28	+34	+50	60	+71	81	+92	103	+114	+125	+136	147	+158
AVE																							
ACHROMATIC RED FIELD - BLUE DISC [MINUS = BLUE ADVANCE]																							
#1	-134	-112	-61	-40	-27	-5	+6	+17	+4	+6	+25	+47	+60	+68	+81	+90	+103	+111	+124	+132	+144	+155	+168
#2	-83	-61	-40	-27	-5	+6	+17	+4	+6	+25	+47	+60	+68	+81	+90	+103	+111	+124	+132	+144	+155	+168	
#3	-70	-48	-27	-5	+6	+17	+4	+6	+25	+47	+60	+68	+81	+90	+103	+111	+124	+132	+144	+155	+168		
AVE																							

OBSERVER _____
 OBS. # _____
 DATE _____
 Lenses A _____
 B _____
 R _____
 * VALUES IN BODY OF TABLE ARE ARC SECONDS
 ACHROM 1. _____
 2. _____
 3. _____
 Σ _____
 AVE.
 BLUE F. 1. _____
 2. _____
 3. _____
 Σ _____
 AVE.
 RED F. 1. _____
 2. _____
 3. _____
 Σ _____
 AVE.
 BL. + R. AVE.

DIFFERENCE + SCORE
 CHROMATIC SCORE
 ACHROMATIC SCORE

FIGURE III-1. PERIPHERAL SCAN CHROMOSTEREOPSIS TEST DATA SHEET

REFERENCES

- Bedford, R. E. and Wyszecki, G., "Axial Chromatic Aberration of the Human Eye." J. Opt. Soc. Amer., 1957, 47, 564.
- Borish, I. M. (Ed.) Clinical Refraction. (3rd Ed.) Chicago: The Professional Press, Inc., p. 1218.
- Bruecke, E., Archives Anatomie and Physiologie, 1844, p. 444 (from Vos. 1960).
- Duke-Elder, S., and Abrams, D., "Ophthalmic Optics and Refraction." Vol. V of System of Ophthalmology. S. Duke-Elder (Ed.). St. Louis: C. V. Mosby Co., 1970, 135.
- Einhoven, W., "Stereoscopie durch Farbendifferenz," Graefes Archives fur Ophthalmologie, Vol. 31, 1885, pp. 211-233 (in Rosch, 1954).
- Haines, R. F., "Dimensions of the Apparent Pupil When Viewed at Oblique Angles." Amer. J. Ophthal., 1969, 68, 649-656.
- Hertzberg, H. T. E., Daniels, G. S., and Churchill, E., "Anthropometry of Flying Personnel - 1950." WADC Technical Report 52-321, Wright Air Development Center, WPAFB, Ohio, 1954, p. 61.
- Kishto, B. N., "The Colour Stereoscopic Effect." Vision Research, 1965, 5, 313-329.
- Kraft, C. L., Booth, J. M., and Boucek, G. P., Jr. Achromatic and Chromatic Stereoscopic Performance. Paper Presented at 12th Congress of the International Society for Photogrammetry, Ottawa, Canada, July 2, 1972.
- Kraft, C. L., and Anderson, C. D. "Prediction of Target Acquisition Performance of Aerial Observers and Photointerpreters With and Without Stereoscopic Aids." AMRL Technical Report 73-36, Aerospace Medical Research Laboratory, WPAFB, Ohio, December, 1973.
- Kraft, C. L., and Anderson, C. D., "Development of Criteria for Printing Color Reconnaissance Stereo Strip Photography for Interpretation Under Dynamic Viewing Condition." AMRL Technical Report 73-104, Aerospace Medical Research Laboratory, WPAFB, Ohio, December, 1973.
- Liesegang, F. P., "Die Farbenstereoskopie," Kinotechnik und Filmtechnik, 1944, 26, 59-62 (in Rosch, 1954).
- Luckiesh, T. H., "On 'Retiring' and 'Advancing' Colors," Amer. Psychol., 1918, 29, 182-186.

Mattas, R. B., "Some Effects of Chromostereopsis on Stereoscopic Performance." Unpublished Dissertation submitted to The Catholic University of America, Wash., D. C., 1974.

Owens, D. A., and Liebowitz, A. W., "Chromostereopsis With Small Pupils," J. Opt. Soc. Am., 1975, 65, 358-359.

Peucker, K., Shatten Plastik und Farbenplastik, Vienna, 1898.

Rosch, S. Von: "Ueber Farbenplastik;" Praxis der Physik/Chemie/Photographie; 1954, 3, 331-336, (Partial translations of Deane B. Judd of December 1965 used by the authors).

Vos, J. J., "Some New Aspects of Color Stereoscapy," Optical Soc. Amer., 1960, 50, 785-790.

Vos, J. J., "The Color Stereoscopic Effect," Vision Research, 1966, 6, 105-107.