

AD-A040 541

COAST GUARD RESEARCH AND DEVELOPMENT CENTER GROTON CONN F/G 6/6  
A PRELIMINARY TEST OF A GOVERNMENT-OWNED LOCAL AREA OIL ON WATE--ETC(U)  
JUN 76 J R WHITE

UNCLASSIFIED

CGR/DC-9/76

C6-D-121-76

NL

(OF)

AD  
A040541

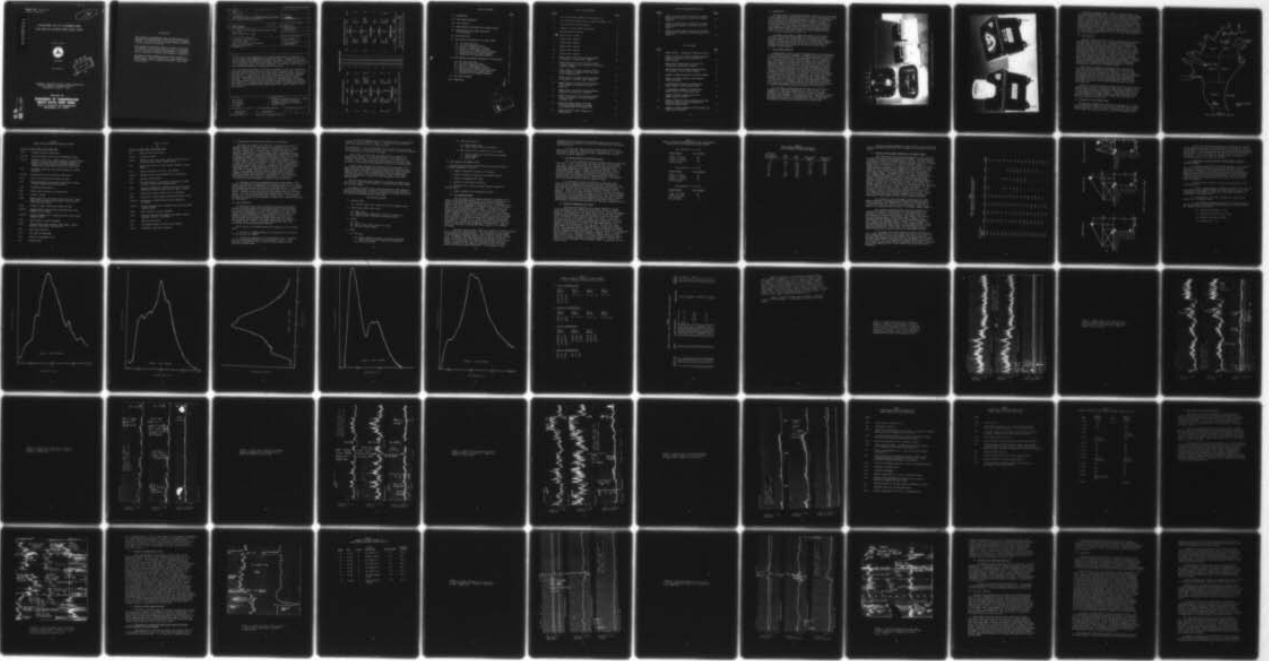

END

DATE  
FILMED  
7-77

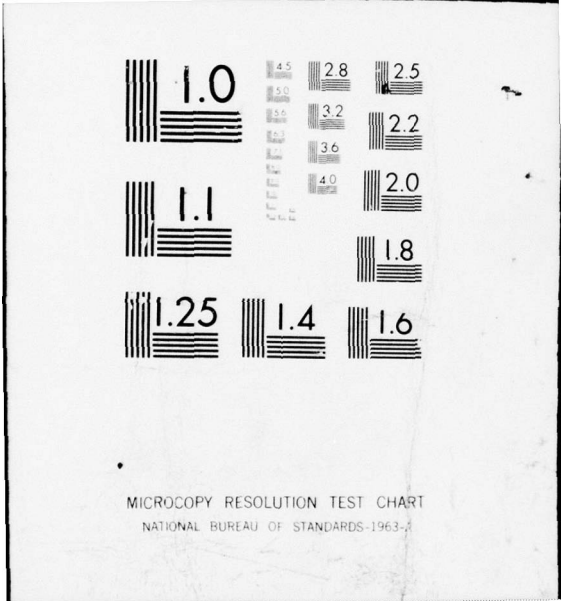

Report No. CG-D-121-76  
Task No. 764241.2/15

14

ADA 040541

A PRELIMINARY TEST OF A GOVERNMENT-OWNED  
LOCAL AREA OIL ON WATER SURVEILLANCE SYSTEM

James R. White



June 1976

Final Report

DDC  
RECEIVED  
JUN 15 1977  
C

Document is available to the U.S. public through the  
National Technical Information Service,  
Springfield, Virginia 22161

Prepared for

**DEPARTMENT OF TRANSPORTATION**  
**UNITED STATES COAST GUARD**  
Office of Research and Development  
Washington, D.C. 20590

AD No. \_\_\_\_\_  
DDC FILE COPY

NOTICE

This document is disseminated under the sponsorship of the Department of Transportation in the interest of information exchange. The United States Government assumes no liability for its contents or use thereof.

The contents of this report reflect the views of the Coast Guard Research and Development Center, which is responsible for the facts and accuracy of data presented. This report does not constitute a standard, specification or regulation.

The United States Government does not endorse products or manufacturers. Trade or manufacturers' names appear herein solely because they are considered essential to the object of this report.

1. Report No. CG-D-121-76	2. Government Accession No.	3. Recipient's Catalog No.	
4. Title and Subtitle A PRELIMINARY TEST OF A GOVERNMENT-OWNED LOCAL AREA OIL ON WATER SURVEILLANCE SYSTEM		5. Report Date June 1976	6. Performing Organization Code
7. Author(s) James R. White	8. Performing Organization Report No. CGRDC-9/76	9. Performing Organization Name and Address U. S. Coast Guard Research and Development Center Avery Point Groton, Connecticut 06340	
10. Work Unit No. (TRAIS) 764241.2/15		11. Contract or Grant No.	
12. Sponsoring Agency Name and Address Department of Transportation U. S. Coast Guard Office of Research and Development Washington, DC 20590		13. Type of Report and Period Covered Final Report	
14. Sponsoring Agency Code G-DOE-2/TP54			
15. Supplementary Notes			
16. Abstract A field test of three fixed site, oil on water point sensors was conducted in New York Harbor from September 1975 through March 1976. Over 2000 hours of strip chart recordings were analyzed to determine such items as, number of alarms for various threshold levels and time durations, effects of tidal fluctuations, effects of oil background levels, and sensor reliability. In addition, surface samples were obtained and analyzed to provide ground truth data.  To be operationally desirable, the sensors comprising a local area surveillance system must unequivocally initiate an alarm in one circumstance only. That is the case when there is a surface oil film large enough to warrant cleanup, preventative measures, or legal action. The result of the Bayonne evaluation indicated that this criteria would be difficult to meet with the two types of sensors evaluated. The problems of thin film sensitivity, threshold levels, and alarm time delays combine to raise serious questions to the practicability of employing point sensors in a widespread harbor monitoring system. It appears they would be more effective monitoring specific problem areas such as moored tankers or storm drain outfalls.			
17. Key Words point sensor oil detector oil on water oil sensor		18. Distribution Statement Document is available to the U.S. public through the National Technical Information Service, Springfield, Virginia 22161	
19. Security Classif. (of this report) UNCLASSIFIED	20. Security Classif. (of this page) UNCLASSIFIED	21. No. of Pages 70	22. Price

408 730

# METRIC CONVERSION FACTORS

## Approximate Conversions to Metric Measures

Symbol	When You Know	Multiply by	To Find	Symbol
<b>LENGTH</b>				
in	inches	2.5	centimeters	cm
ft	feet	30	centimeters	cm
yd	yards	0.9	meters	m
mi	miles	1.6	kilometers	km
<b>AREA</b>				
in <sup>2</sup>	square inches	6.5	square centimeters	cm <sup>2</sup>
ft <sup>2</sup>	square feet	0.09	square meters	m <sup>2</sup>
yd <sup>2</sup>	square yards	0.8	square meters	m <sup>2</sup>
mi <sup>2</sup>	square miles	2.6	square kilometers	km <sup>2</sup>
	acres	0.4	hectares	ha
<b>MASS (weight)</b>				
oz	ounces	28	grams	g
lb	pounds	0.45	kilograms	kg
	short tons (2000 lb)	0.9	tonnes	t
<b>VOLUME</b>				
tsp	teaspoons	5	milliliters	ml
Tbsp	tablespoons	15	milliliters	ml
fl oz	fluid ounces	30	milliliters	ml
c	cups	0.24	liters	l
pt	pints	0.47	liters	l
qt	quarts	0.95	liters	l
gal	gallons	3.8	liters	l
ft <sup>3</sup>	cubic feet	0.03	cubic meters	m <sup>3</sup>
yd <sup>3</sup>	cubic yards	0.76	cubic meters	m <sup>3</sup>
<b>TEMPERATURE (exact)</b>				
°F	Fahrenheit temperature	5/9 (after subtracting 32)	Celsius temperature	°C

## Approximate Conversions from Metric Measures

When You Know	Multiply by	To Find	Symbol
<b>LENGTH</b>			
millimeters	0.04	inches	in
centimeters	0.4	inches	in
meters	3.3	feet	ft
kilometers	1.1	yards	yd
	0.6	miles	mi
<b>AREA</b>			
square centimeters	0.16	square inches	in <sup>2</sup>
square meters	1.2	square yards	yd <sup>2</sup>
square kilometers	0.4	square miles	mi <sup>2</sup>
hectares (10,000 m <sup>2</sup> )	2.5	acres	
<b>MASS (weight)</b>			
grams	0.035	ounces	oz
kilograms	2.2	pounds	lb
tonnes (1000 kg)	1.1	short tons	
<b>VOLUME</b>			
milliliters	0.03	fluid ounces	fl oz
liters	2.1	pints	pt
liters	1.06	quarts	qt
liters	0.26	gallons	gal
cubic meters	35	cubic feet	ft <sup>3</sup>
cubic meters	1.3	cubic yards	yd <sup>3</sup>
<b>TEMPERATURE (exact)</b>			
Celsius temperature	9/5 (then add 32)	Fahrenheit temperature	°F

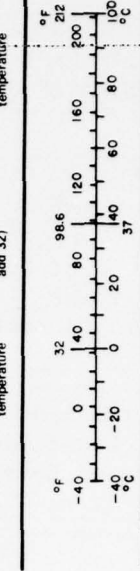
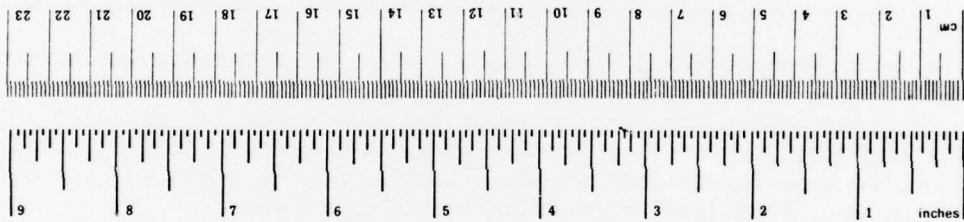

\*1 in = 2.54 (exact). For other exact conversions and more detailed tables, see NBS Misc. Publ. 286, Units of Weights and Measures, Price \$2.25, SD Catalog No. C13,10-286.

TABLE OF CONTENTS

	<u>Page</u>
1.0 INTRODUCTION	1
2.0 POINT SENSOR OPERATION	1
3.0 SITE SELECTION	4
4.0 INSTALLATION OF THE RAMBIE OIL ON WATER SENSOR	4
5.0 INSTALLATION OF THE WRIGHT AND WRIGHT OIL FILM MONITOR	10
6.0 DATA COLLECTION	10
7.0 DATA ANALYSIS FOR RAMBIE OIL ON WATER SENSOR	12
7.1 Oil Alarm Time Delay	12
7.2 Oil Alarm Threshold Setting	13
7.3 Effects of Background Oil Levels	13
7.4 Effects of Tidal Height Variations	16
7.5 Verification of Sensor Operation Through Chemical Analysis of Surface Samples	19
7.6 Reliability for Unattended Operation	47
8.0 DATA ANALYSIS FOR WRIGHT AND WRIGHT OIL FILM MONITOR	48
8.1 Oil Alarm Time Delay	48
8.2 Oil Alarm Threshold Setting	48
8.3 Effects of Background Oil Level	51
8.4 Effects of Tidal Height Variations	51
8.5 Verification of Sensor Operation Through Chemical Analysis of Surface Samples	51
8.6 Reliability for Unattended Operation	59
9.0 OIL SPILLS DETECTED	59
10.0 CONCLUSIONS	60

✓

SEARCHED \_\_\_\_\_

SERIALIZED \_\_\_\_\_

INDEXED \_\_\_\_\_

FILED \_\_\_\_\_

NOV 1964

FBI - MEMPHIS

BY \_\_\_\_\_

DATE \_\_\_\_\_

AVAIL. BY \_\_\_\_\_

SP-1

**A**

LIST OF ILLUSTRATIONS

<u>Figure</u>		<u>Page</u>
1	Oil on Water Sensor Manufactured by Rambie, Inc.	2
2	Oil Film Monitor Manufactured by Wright and Wright, Inc.	3
3	Point Sensor Field Test Location	5
4	Diagram of Initial Sensor Installation	7
5	Modified Sensor Platforms	18
6	Typical Type 1 Spectra	21
7	Typical Type 2 Spectra	22
8	Typical Type 3 Spectra	23
9	Typical Type 4 Spectra	24
10	Typical Type 5 Spectra	25
11	Typical Type 6 Spectra	26
12	Rambie Sensor Strip Chart recording showing no response to visible sheen, Sample 2	31
13	Rambie Sensor Strip Chart recording showing a slight response, but not enough to reach alarm threshold, Sample 5	33
14	Rambie Sensor Strip Chart recording showing strong response to Sample 8 which was shown to not contain any oil	35
15	Rambie Sensor Strip Chart recording showing no response to a visible sheen, Sample 21	37
16	Rambie Sensor Strip Chart recording showing strong response to invisible oil film, Sample 29	39
17	Rambie Sensor Strip Chart recording showing response to invisible oil, Sample 30	41
18	Rambie Sensor Strip Chart recording showing 54-minute response to a visible sheen on 27 January 1976	43
19	Wright and Wright Sensor Strip Chart recording showing 204-minute response to a visible sheen on 27 January 1976	50
20	Wright and Wright Sensor Response to a Visible Sheen	52

LIST OF ILLUSTRATIONS (Cont'd)

<u>Figure</u>		<u>Page</u>
21	Wright and Wright Sensor Strip Chart recording showing sharp response to visible oil streaks, Sample 14	55
22	Wright and Wright Sensor Strip Chart recording showing sharp response to invisible oil film, Sample 17	57
23	Wright and Wright Sensor Strip Chart recording showing sharp response to visible streaks of oil, Sample 21	58

LIST OF TABLES

<u>Table</u>		<u>Page</u>
1	Rambie Sensors: Installation Phase Main Events	8
2	Number of Alarms for Various Threshold and Time Durations from 1001 Hours of Operation of Rambie Sensors	14
3	Rambie Sensor Signatures for Various Film Thicknesses and Petroleum Products	15
4	Rambie Sensor Ratio Channel Voltage Readings as a Function of Lens to Water Height	17
5	Summary of Chemical Analysis of Surface Samples	27
6	Summary of Samples Taken to Verify Rambie Sensor Operation	28
7	A Chronological Summary of Problems with Rambie Sensor #1 in Operational Phase	44
8	A Chronological Summary of Problems with Rambie Sensor #2 in Operational Phase	45
9	Summary of Battery Voltage Levels for Rambie Sensors #1 and #2	46
10	Number of Alarms for Various Threshold and Time Durations from 1132 Hours of Operation of Wright and Wright Sensor	49
11	Summary of Samples Obtained to Verify Wright and Wright Sensor Operation	53

## 1.0 INTRODUCTION

The Coast Guard, as the Government agency charged with the enforcement of laws prohibiting the discharge of oil into or upon the navigable waters of the United States, adjoining shorelines, or into or upon the waters of the contiguous zone has sponsored the development of a number of devices which detect surface oil on water. The units sponsored were both fixed mounted point sensors and scanning sensors with ranges up to 100 meters. The first sensors delivered to the Coast Guard under these development contracts were the point sensors manufactured by Rambie, Inc., of Irving, Texas (Figure 1), and by Wright and Wright, Inc., of Newton, Massachusetts (Figure 2).

To evaluate the concept of employing systems of point sensors for harbor oil pollution surveillance, it was decided to install some point sensors in an actual harbor for a six-month field test. The Kill Van Kull region of New York Harbor was specified by Commandant (G-DET-1) for the field test as this was an area with numerous oil-handling facilities and a history of the most oil spills of any location in New York Harbor.

## 2.0 POINT SENSOR OPERATION

Suitable sensor sites are greatly dependent upon the characteristics of the individual sensors available. The Rambie point sensor operation is based on the differences in the reflectance properties of water and oil in the 2 micron to 4 micron spectral region. In the transmitter unit, radiation from a 60-watt tungsten halogen lamp is modulated by a mechanical chopper and directed by a lens to the water surface. The reflected radiation is collected by a receiver unit, where a dichroic filter mirror directs the 3.65 to 3.95 micron wavelength band and the 3.35 to 3.45 micron wavelength band into separate thermoelectrically cooled lead selenide detectors. The signals are then electronically processed to obtain the logarithm of the ratio of the reflected signal at 3.4 microns and 3.8 microns. By using the ratio signal, the effects of surface wave turbulence can be eliminated. The output signal is adjusted to zero for clean water and will decrease to approximately -.5 volts when oil is detected. The oil alarm threshold is adjustable from -.25 to -.58. To operate properly, the sensor must be vertical to the water and between 10 feet and 100 feet above the water's surface. It requires approximately 80 watts of power at 115 VAC at 60 Hz.

The oil sensor is weatherproof and all electronic circuits are designed to be temperature stabilized from  $-28^{\circ}\text{C}$  to  $+65^{\circ}\text{C}$ . The transmitter unit and power supply unit are contained in separate explosion-proof enclosures. The receiver circuits, except power sources and relays, were designed to be intrinsically safe. The power source and relays are located in the explosion-proof enclosure while the intrinsically safe circuits are located in the receiver unit.

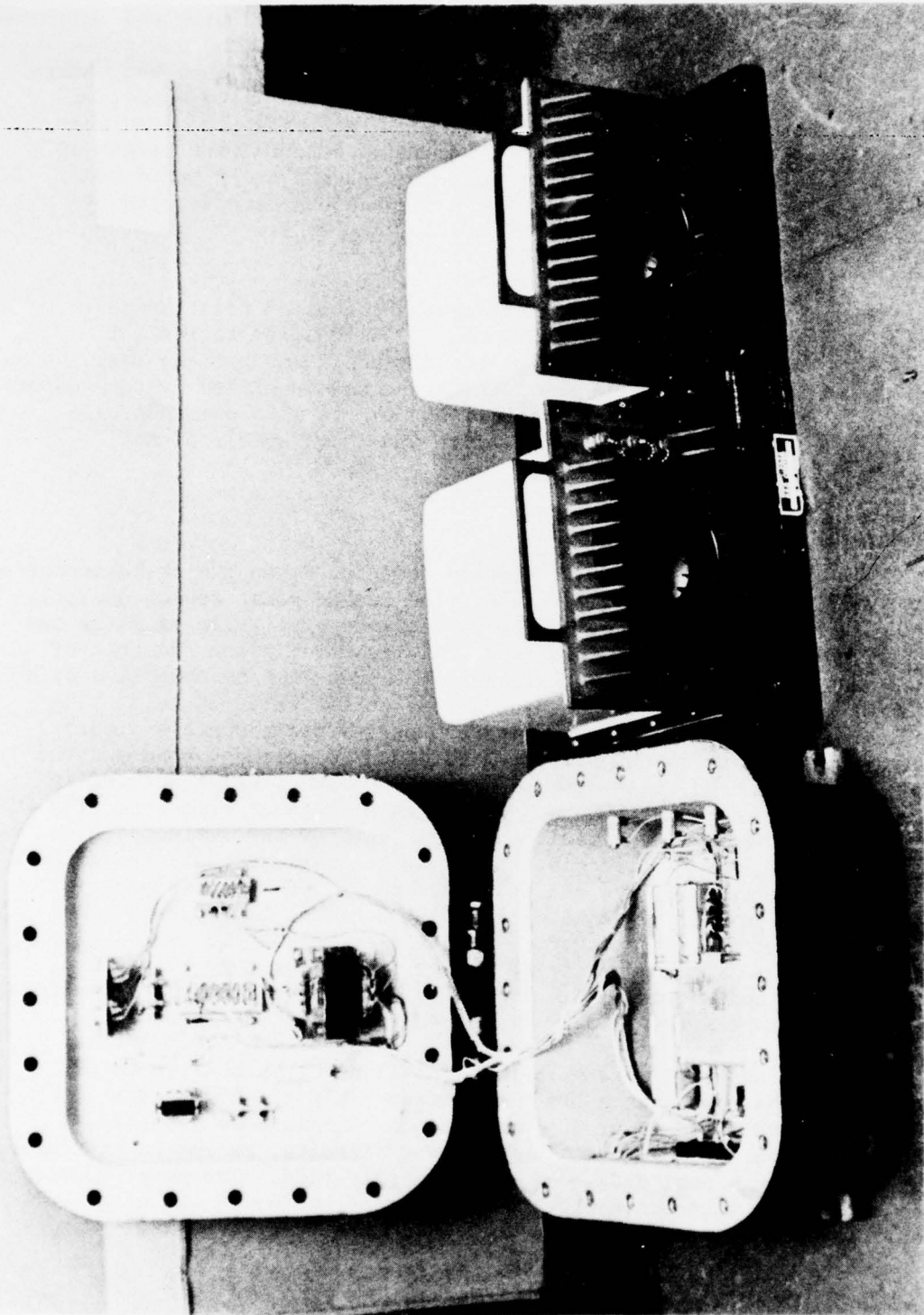

FIGURE 1. OIL ON WATER SENSOR MANUFACTURED BY RAMBIE, INC.



FIGURE 2. OIL FILM MONITOR MANUFACTURED BY WRIGHT AND WRIGHT, INC.

The Wright and Wright sensor, called an Oil Film Monitor, also is an infrared reflectance device. It used a 500-watt tungsten halogen lamp and a parabolic reflector to direct the radiation to the water's surface. The receiver unit collects the reflected radiation with an arsenic trisulfide lens and focuses it into the receiver unit where it passes through two optical interference filters in a rapidly rotating filter wheel to an ambient temperature indium arsenide detector. The filters allow radiation in the 2.4 to 2.6 micron and 3.0 to 3.2 micron wavelength bands to alternately reach the signal detector. The ratio of the 2.5 micron to 3.1 micron signals is then electronically processed. Its value should be approximately 1.8 volts for water and increase to over 2.2 volts for oil.

### 3.0 SITE SELECTION

An initial search of the Kill Van Kull waterfront discovered only two promising installation sites. One was an oil company pier at Constable Hook, and another at an oil company pier at Bergen Point. Suitable sites were very scarce because most piers in this area are less than 10 feet above high tide level and actively in use. As the sensors must extend over the water at least 10 feet above the surface, they would be subject to damage from vessels using most piers unless sheltered spots could be located. As the sites chosen at the two oil company piers were both Class I, Division I, Group D hazardous areas, all electronic and electrical devices had to meet the requirements of the National Electrical Code prior to installation. To verify the explosion-proof and intrinsic safety properties of the Rambi sensor, one was evaluated by Factory Mutual Research of Norwood, Massachusetts, under Contract DOT-CG-81-75-1396.

Their report, completed on 30 September 1975, verified that both explosion-proof enclosures were adequate but stated that the sensor was not intrinsically safe as constructed. For this reason, the oil pier sites were abandoned and a search conducted for alternative non-hazardous locations in the Kill Van Kull area. The particular site decided upon was the end of the Military Ocean Terminal pier in Bayonne, New Jersey, at the northeast approach to Kill Van Kull. The portion of the pier selected was inactive and about five feet above high tide.

Figure 3 is an extract from report number CG-D-6-75 by Ivan Lissauer. In this report, called "A Technique for Predicting the Movement of Oil Spills in New York Harbor," the Military Ocean Terminal field test site is shown almost in the center of Region 1. Region 1 was found to be the area containing the largest number of oil-handling facilities and was the location of 74 percent of the reported New York Harbor oil spills for the years 1971 and 1972.

### 4.0 INSTALLATION OF THE RAMBIE SENSOR

Two mounting platforms were constructed in September 1975 to raise the oil sensors to a height of 12.5 feet above high tide and to provide an area for access to the oil sensor. The platform also had to extend the oil sensor out beyond the sea wall to avoid the splashing effect

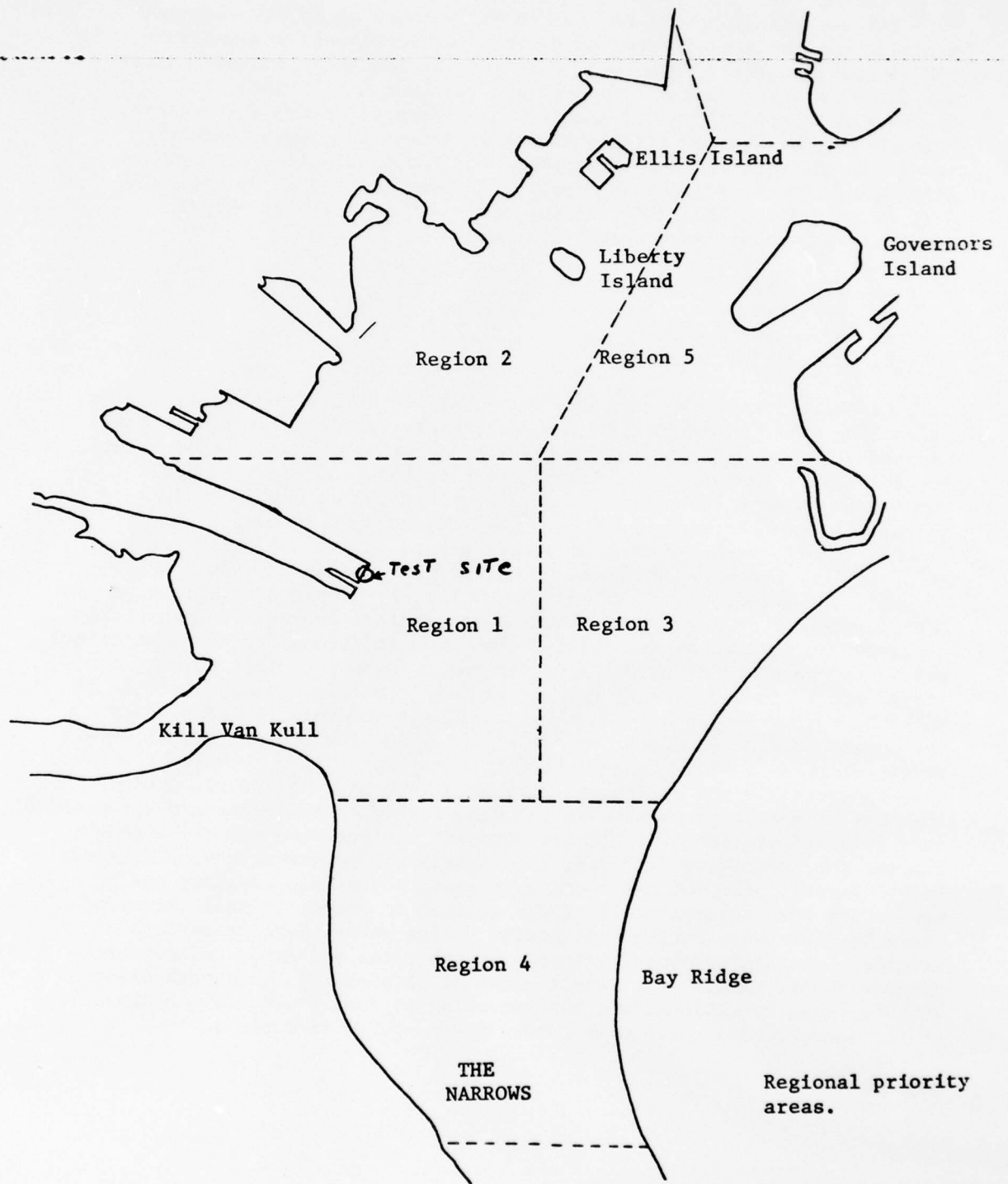

FIGURE 3  
POINT SENSOR FIELD TEST LOCATION

from waves breaking against the sea wall. Figure 4 is a diagram of the original sensor platforms.

Before installing the two Rambie oil sensors at MOTBY, each unit was electronically calibrated on a test bench designed by Coast Guard R&D Center personnel. Many discrepancies between the technical manual and actual practice were discovered and resolved by talking with Mr. Guy Rambie, the president of Rambie, Inc. Several of the adjustments, which determine the operating characteristics of the sensor, are very sensitive and contribute to the problem of recognizing correct optical alignment. Once installed at Bayonne, the sensors had to be optically aligned. To accomplish this, it was necessary to have the proper environmental conditions, which included:

- a. Mid tide
- b. Very calm sea state
- c. Clean surface water
- d. No precipitation

Of these items, the calm sea state was the hardest to acquire. The prevailing water conditions at Bayonne usually consisted of considerable roughness due to wind and vessel traffic in daylight hours. As a result, the best times for optical alignment were in the late night or early morning hours when the surface conditions were the calmest. Optical alignment of the Rambie sensor is a very delicate, time-consuming procedure. The sensor cannot be simply placed on a stand, visually adjusted for proper orientation, turned on, and be expected to work. Instead, the detector outputs must be closely monitored with either an oscilloscope or voltmeter and then the transmitter and receiver carefully adjusted for maximum signal. After this, the individual channel amplifiers must be adjusted to achieve the proper ratio value for clean water. The final test is to verify that the sensor will alarm for an oil slick after suitable output levels have been achieved. It was observed that often the sensors would not alarm for oil slicks even with channel signal levels of two or three volts. Conversation with Mr. Guy Rambie revealed that this was possible and indicated improper alignment. Mr. Rambie agreed that the alignment procedures in the manual were not suitable and recommended more detailed procedures. The ever-present surface chop and tidal height fluctuation, averaging six feet, made successful alignment a very frustrating task. In all, over 100 man-hours were spent adjusting, tweaking and monitoring both sensors until it was decided no better optical alignment could be achieved. During this period, three generations of optical alignment procedures were developed through trial and error and conversations with Mr. Rambie. It wasn't until 31 October 1975 that both sensors were declared operational and the recording of data commenced. A chronology of the installation phase main events is presented in Table 1.

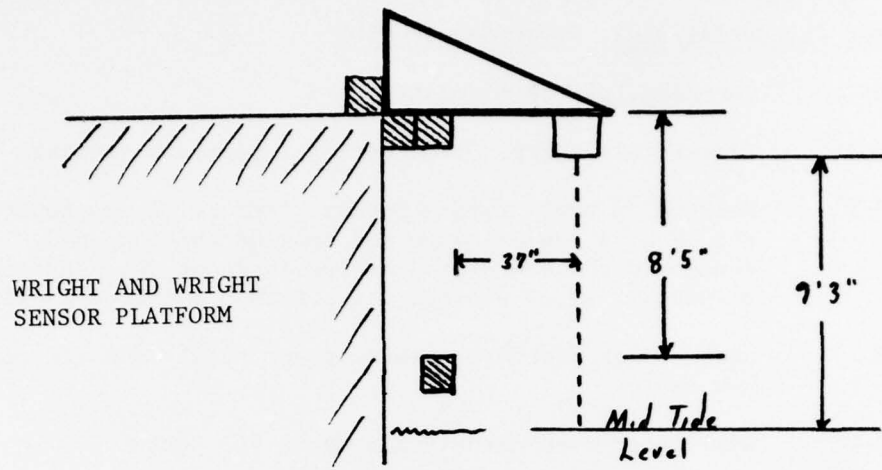

FIGURE 4. DIAGRAM OF INITIAL SENSOR INSTALLATION.

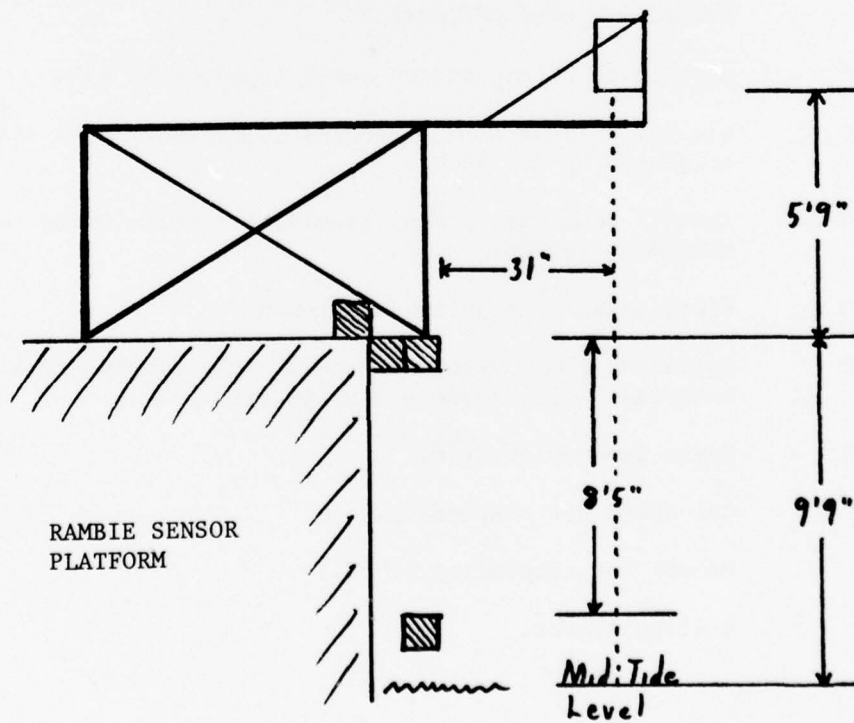

TABLE 1  
RAMBIE SENSOR INSTALLATION PHASE MAIN EVENTS

Sensor #1, Serial #103, Power Supply #103

9/16	Commenced platform construction
9/17,18	Electrical hookup, first optical alignment attempts
9/19-21	Weekend of heavy rain - Sensor platform #1 was apparently struck by a tug or barge and considerably damaged. No damage to the sensor itself but incident demonstrated vulnerability of sensors which extend out from a pier.
9/22	Reconstruct platform, rewire power supply and recorder, new cable.
9/24-26	Realign printed circuit boards at R&D Center.
9/30	Mount #1 on new platform, attempt to align.
10/1	Make modifications to mechanical adjustments, attempt to align, install vessel warning light.
10/5	Transmitter lamp burned out.
10/6	Replace lamp, operation is unsatisfactory.
10/7	Attempt to align.
10/15	Replace sensor #1, serial #103 with serial #101. Found small amount of water in power supply, fuses F3 and F4 failed and were replaced.
10/16	Attempt to align, sealed power supply with RTV.
10/20,21	Realign printed circuit boards using additional steps suggested by Mr. Rambie.
10/22-24	Install realigned pcb's, promising results using refined alignment method.
10/29	Final touches to optical alignment.
10/30	Establish clean water reference, take sample, replace batteries (old 139VDC - new 160 VDC).
10/31	Begin data collection.
11/3	Oil alarm not responding.
11/5	Sensor not responding to oil.
11/7	Realign sensor.

TABLE 1 (Cont'd)

Sensor #2, Serial #102, Power Supply #104

9/16	Began platform construction.
9/17,18	Electrical hookup.
9/19-21	Weekend of heavy rain, power supply secured with two of its twenty bolts, water in power supply.
9/22	Empty water and dry out power supply, attempt to align sensor.
9/23	Replace batteries (old 35VDC - new 180VDC).
9/24-26	Realign printed circuit boards (pcb) at R&D Center.
9/30	Attempt to align sensor.
10/1	Make modifications to mechanical adjustments, attempt to align, install vessel warning lights.
10/6	Sensor not responsive, found R11 open, heavy corrosion evidently from 9/19-21 water leak, F7 open - no parts.
10/7	Repair power supply, sensor still not responsive.
10/8	Replaced K1 in power supply, sealed power supply in RTV.
10/20,21	Realign pcb's using additional steps suggested by Mr. Rambie.
10/22-24	Install realigned pcb's, promising results using refined alignment method.
10/29	Final touches to optical alignment.
10/30	Establish clean water reference, take sample, replace batteries (old 162 - new 182VDC).
10/31	Begin data collection
11/5	Log signature seems to react to tide changes.
11/11	Reestablish clean water reference.

## 5.0 INSTALLATION OF THE WRIGHT AND WRIGHT OIL FILM MONITOR

One Wright and Wright, Inc., Model CX, Infrared Oil Film Monitor had been delivered to the R&D Center and was available for use. It was decided to install the Oil Film Monitor to increase the data collected for later analysis and to evaluate some of the Oil Film Monitor's different characteristics. In this manner, better conclusions could be drawn in regard to what problems were applicable to point sensor systems in general as opposed to individual manufacturer's sensors in particular. The Wright and Wright Oil Film Monitor is designed to operate at a minimum height of 6 feet as compared to 10 feet for the Rambie sensor. It uses a 500-watt lamp (versus Rambie's 60-watt lamp) which illuminates a larger area on the water's surface. It does not have a beamsplitter and employs automatic gain control, as compared to the manually adjusted Rambie amplifiers. Another advantage was the fact that there was no requirement to balance channels 1 and 2 to achieve a zero reference value. It was thought that these features might reduce the optical alignment problems encountered because of relatively low operating heights and large tidal variations. Accordingly, the Oil Film Monitor was installed at the test site on 29 October 1975. It was placed 9'3" above mid tide and extended 37 inches out from the sea wall.

The alignment process was considerably easier for this sensor. Once mounted, the receiver and transmitter were carefully adjusted and the ratio channel monitored with a voltmeter until the maximum signal level was reached. Good alignment could usually be achieved in less than an hour. The alignment should be conducted at mid tide with no precipitation and a clean water surface. However, it did not require as calm a surface water as the Rambie sensor. Also, the two wavelength channel voltage levels did not have to be balanced to set an arbitrary clean water reference level. This eliminated the chance of improper initial adjustment if there was an invisible background oil film present.

## 6.0 DATA COLLECTION

An operational local area oil surveillance system would probably consist of several sensors, the oil alarms of which would be monitored at a central location such as a Coast Guard Captain of the Port office. Because of the experimental nature of the evaluation, the sensor alarm outputs were not telemetered to the CG Captain of the Port office on Governor's Island but were only recorded locally at the test site. Both the Rambie and the Wright and Wright sensor have three analog outputs and two data outputs. The three analog outputs are channel 1, 2, 3 signal levels. The two data outputs are self-test alarm (OK/not OK) and oil alarm (detected/not detected).

The oil alarm on the Rambie sensor may be operated in the following modes:

- a. An alarm is triggered whenever the threshold level is exceeded, for as long as it is exceeded.
- b. An alarm is triggered only if the threshold level is exceeded both at the beginning and end of a preset period of time, T. Once activated, the alarm will stay on until the output signature falls below the threshold level.

c. An alarm is triggered only if the threshold level is continuously exceeded for a preset period of time, T. The alarm will then stay on until the threshold level is no longer exceeded.

The time period, T, can be set anywhere from 1 second to several minutes. The adjustability of the threshold level and the time, T, provides flexibility in the operational utilization of the sensor.

The oil alarm for the Wright and Wright sensor is adjustable in three discrete steps of 10, 30 and 100 seconds. These times do not represent the time delay from introduction of oil to activation of the oil alarm. Rather, they indicate the time required for the analog signal to reach one time constant (approximately 63 percent) of its final value.

An event-camera recorder was installed on the #1 platform. The data outputs from both Rambie sensors were fed into the camera recorder. Whenever either of the four data outputs changed state, the event-camera takes a picture of a 24-hour calendar/clock and an LED display which indicates the state of the four data outputs. Chart recorders were also used periodically to acquire detailed information on the three analog outputs.

The data outputs and analog outputs of the Wright and Wright sensor were fed into a chart recorder capable of recording three analog signals and two event outputs.

The resident technician was on hand from 0800 until 1600 weekdays to collect ground-truth data. In effect, the ground-truth data verifies or disputes the information supplied by the sensors and provides information on conditions surrounding any particular event.

#### ROUTINE DATA RECORDED

- a. Daily at 0800:
  - (1) 180 VDC battery bias voltage level for each Rambie sensor.
- b. Fourth hourly (0800, 1200, 1600):
  - (1) Time, date
  - (2) General weather (temperature, rain, fog, windy, etc.)
  - (3) General surface description (northerly current)
- c. Hourly:
  - (1) Time
  - (2) Lens to water height (function of tide)
  - (3) Sea state (calm, choppy)
- d. Event:
  - (1) Oil alarm
    - (a) Verify presence or absence of oil with photograph, sample or description (technician's discretion).
    - (b) Record hourly data

- (2) Self-test alarm off
  - (a) Record hourly data
  - (b) Sensor failure cause if determined
- (3) When surface slick is present but no oil alarm
  - (a) Collect sample, use discretion for photograph and description.
  - (b) Hourly data

## 7.0 DATA ANALYSIS FOR RAMBIE SENSOR

The data was divided into several distinct areas which will be considered separately. They are:

- a. Number of alarms as a function of time delay.
- b. Number of alarms as a function of threshold setting.
- c. Effects of background oil levels.
- d. Effects of tidal height variations.
- e. Verification of operation through chemical analysis of surface sample.
- f. Sensor reliability for unattended operation.

### 7.1 Oil Alarm Time Delay

The oil alarms for both Rambie sensors were initially set to operate in the mode that requires oil to be present continuously for a period of time adjustable from instantaneous to about 36 minutes. Sensor #1 was set at instantaneous and #2 was set at a nine-second delay. Both oil alarm ratio thresholds or "signatures" were set at -.25 volts with 0.0 volts corresponding to clean water. It became evident that longer time delays would be required to reduce the number of short duration alarms that were recorded. In one typical nine-hour period, 38 oil alarms were recorded, 29 of which persisted for a period of less than two minutes. It was only on two occasions in the entire five-month test period that the resident technician ever observed more than small spots, patches or streaks of oil. These two instances are discussed in Section 9.0. Because of the numerous alarms for spots of oil, the delays for both sensors were increased on 12 December 1975. Sensor #1 was set at 2 minutes, 17 seconds and Sensor #2 was set at 4 minutes, 34 seconds.

The event camera recorder proved to be inferior to the multi-channel chart recorders for collecting data. The large number of alarm changes of state made film analyzing tedious. Also, failures were encountered in the photographic lighting system as well as with the 24-hour calendar clock. In addition, each film frame could only provide information limited to the particular alarm threshold and time delay in use on each sensor. On the other hand, the chart recording could be analyzed to provide information on the number of alarms of any particular time duration and alarm threshold combination. In this manner, various

combinations could be considered to determine what blend of delay and threshold would be required to eliminate the numerous alarms from patches and streaks of oil.

In total, 1001 hours of chart recordings were obtained from Rambie sensor operation. From them, Table 2 was completed. It tabulates the number of alarms which would have been transmitted under varying delay and threshold conditions.

### 7.2 Oil Alarm Threshold Setting Rambie Sensor

The oil alarm threshold setting of the Rambie Sensor is adjustable from  $-.25$  to  $-.58$  V. Both sensors were initially set for the minimum  $-.25$  volts. It was discovered that the signature level was affected by tidal height variations, sea conditions, and oil background levels. It often became negative when no visible oil film was observed. Table 2 illustrates how the number of alarms initiated can be affected by the oil alarm threshold setting. The response of the Rambie sensor as a function of oil film thickness had been investigated and recorded in a report entitled "Oil-on-Water Sensor," number CG-D-87-74. The signature variations reported in that report are listed in Table 3.

It is extremely difficult to observe oil films less than a micron thick with choppy surface conditions and poor viewing angles. To avoid the sensor responding to these nearly invisible films which may just be background level oil pollution, the threshold should be set higher than  $-.40$ . However, there is a problem setting the threshold this far negative. If the tidal height variations (Section 7.4) drive the signature positive  $.20$  volts or so, then the presence of an oil film will not decrease the signature level far enough to trigger the alarm. Thus actual threshold levels must be a compromise between alarming for films too thin to require cleanup action and possibly not alarming for large volume films due to tidal height fluctuations which had driven the clean water signature positive.

### 7.3 Effects of Background Oil Levels

This particular problem was not realized immediately because it is concerned with thin residual oil films which, because of viewing angles and surface chop, are not visible from the pier. During the alignment process of the Rambie sensor, the signal levels from the two lead selenide detectors must be balanced, while the instrument is viewing clean water, to set the channel 3 water signature level to  $0.0$  volts. If the water surface is not really oil free as it appears, the signature level will be set incorrectly and the sensor's operation might be unreliable. The first example of this occurred on 31 October 1975 when Rambie sensor #2 was aligned over what was believed to be clean water. At this time, surface water sample #1 was obtained for later analysis by the R&D Center Chemistry Branch. The subsequent analysis showed oil present in Sample 1 which meant the zero signature had been incorrectly set. This fact accounts for the apparent erratic performance of the sensor compared to samples 2 and 3. In sample 2, oil was visible. Its presence was verified by chemical analysis but the sensor did not alarm. In sample 3, no oil was visible and chemical analysis verified no oil present but the oil alarm was activated. The ratio was reset to zero on 11 November 1975 and sample 4 taken. It proved to, in fact, contain no oil.

TABLE 2  
 NUMBER OF ALARMS FOR VARIOUS THRESHOLD AND TIME DURATIONS  
 FROM 1001 HOURS OF OPERATION OF RAMBIE SENSORS

Alarm Threshold =  $-.25$  volts

<u>Alarm Duration</u>	<u>No. of Alarms</u>
2 mins. to 5 mins.	187
5 mins. to 10 mins.	70
10 mins. to 20 mins.	38
over 20 minutes	14

Alarm Threshold =  $-.35$  volts

<u>Alarm Duration</u>	<u>No. of Alarms</u>
2 mins. to 5 mins.	92
5 mins. to 10 mins.	38
10 mins. to 20 mins.	13
Over 20 minutes	9

Alarm Threshold =  $-.45$  volts

<u>Alarm Duration</u>	<u>No. of Alarms</u>
2 mins. to 5 mins.	43
5 mins. to 10 mins.	20
10 to 20 mins.	7
Over 20 minutes	3

TABLE 3  
 RAMBIE SENSOR SIGNATURES FOR VARIOUS  
 FILM THICKNESSES AND PETROLEUM PRODUCTS

Estimated Film Thickness in Microns	Diesel #2	Diesel #6	Sweet Crude EXXON	Quaker State 10W30
.15	-.05	0	-.05	-.20
.31	-.06	-0.05	-.175	-.20
1.0	-.17	-.55	--	-.50
2.0	-.40	-.60	-.35	-.50
4.0	-.60	-.40	-.50	-.50
7.0	-.60	-.70	-.60	-.50
35	.60	-.60	-.60	-.50
70	-.60	-.60	-.60	-.50
700	-.55	-.60		

The sensor was more sensitive to thin oil films than the human eye. Thus when setting the clean water ratio a sample must be analyzed for verification.

#### 7.4 Effects of Tidal Height Variations on the Rambie Sensor

Both Rambie sensors were initially installed 15.5 feet above the mid tide level and optically aligned for that height. Although the sensor is designed to operate at a minimum height of ten feet, the tidal range of nearly six feet at the Bayonne site produced noticeable variations in output signal levels of channels 1 and 2. The alarm channel, channel 3, compares the log of the ratio of channels 1 and 2 and should theoretically remain constant as channels 1 and 2 amplitudes fluctuate equally. Even though all circuit boards were pre-aligned at the R&D Center, there was still some variation in the alarm channel output that corresponded to tidal height changes. For example, consider the chart recording data from 4 December 1975 presented in Table 4. The average voltage level of channel 3 was determined over a period of nearly seven tidal cycles. Although the surface wave conditions must have been changing somewhat, there is a definite correlation between the lens to water height and the channel 3 voltage level. At high tide (12.8 feet lens to water), the average signal was .22 volts. From there the average signal level decreased to zero around mid tide and continued dropping to a negative .27 volts at low tide (19.2 feet lens to water). Thus at high tide, a -.5 volt decrease in channel 3 initiated by the presence of an oil film would not trigger an alarm if the threshold was set below -.25 volts. At low tide, the signal level would already be negative thus increasing the possibility of false alarms with minor further signal aberrations.

In an attempt to reduce the signal fluctuations from tidal height variations, both Rambie sensor platforms were extended another several feet higher on 10 February 1976. Sensor #1 was increased to 19.5 feet above mid tide level, a 26 percent increase. Sensor #2 was moved to 21.1 feet above mid tide level, a 36 percent increase (Figure 5).

The increased operating heights effectively eliminated the variations in channel 3 ratio levels. The increased stability was achieved at the price of reduced channel 1 and 2 signal levels as the intensity is inversely proportional to the square of the distance from the radiating source. At the lower height, channel 1 and 2 voltages had seldom dropped below one volt for any extended length of time. However, at the higher heights, channel 1 and 2 voltages for both sensors seldom went above one volt. They averaged around .5 volts, and with anything above normal surface chop decreased even lower, often less than 50 millivolts. At this point, the ratio channel would go sharply positive and the sensor would not be functioning correctly.

It was thought that the main reason the sensor was affected by tidal height variations at the lower height was because of the use of an optical beamsplitter to direct the radiation into the two detectors. If the light beam impinged on different spots of the beamsplitter at slightly different angles, then the proportion of light directed to each detector would change. As the sensor height was increased, the movement of the light spot on the beamsplitter due to tidal height fluctuations would become negligible.

TABLE 4  
 RAMBIE SENSOR RATIO CHANNEL VOLTAGE READINGS  
 AS A FUNCTION OF LENS TO WATER HEIGHT

Lens to Water Height (feet)	2 Dec	3 Dec	4 Dec	5 Dec	8 Dec	11 Dec	12 Dec	Average
12.8	.20	.25	.25	.20	.23	--	--	.22
13.2	.23	.25	.25	.25				.23
13.6	.21	.25	.25	.28				.24
14.0	.25	.25	.25	.25				.24
14.4	.20	.22	.25	.22	.22	.30		.23
14.8	.17	.21	.25	.22	.23	.30	.10	.21
15.2	.12	.17	.22	.18	.21	.15	.10	.16
15.6	.12	.15	.20	.18	.18	.12	0.00	.14
16.0	.07	.15	.18	.16	0.00	0.00	0.00	.08
16.4	.03	.05	.18	.12	--	--.05	-.05	.05
16.8	0.00	-.05	.15	.08	--	-.05	-.05	.08
17.2	-.07	-.08	.10	0.00	--	--	-.08	-.03
17.6	-.10	-.12	0.00	-.03	--	--	-.15	-.08
18.0	-.13	-.13	-.08	-.08	--	--	-.15	-.11
18.4	-.14	-.20	-.20	-.10	--	--	--	-.16
18.8	-.18	-.16	-.25	-.15	--	--	--	-.19
19.2	--	-.28	-.25	--	--	--	--	-.27

RAMBIE SENSOR #1

RAMBIE SENSOR #2

WRIGHT & WRIGHT SENSOR

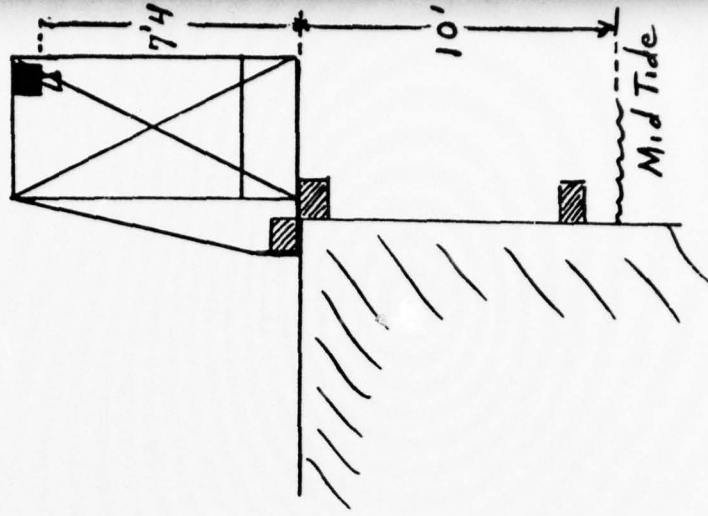
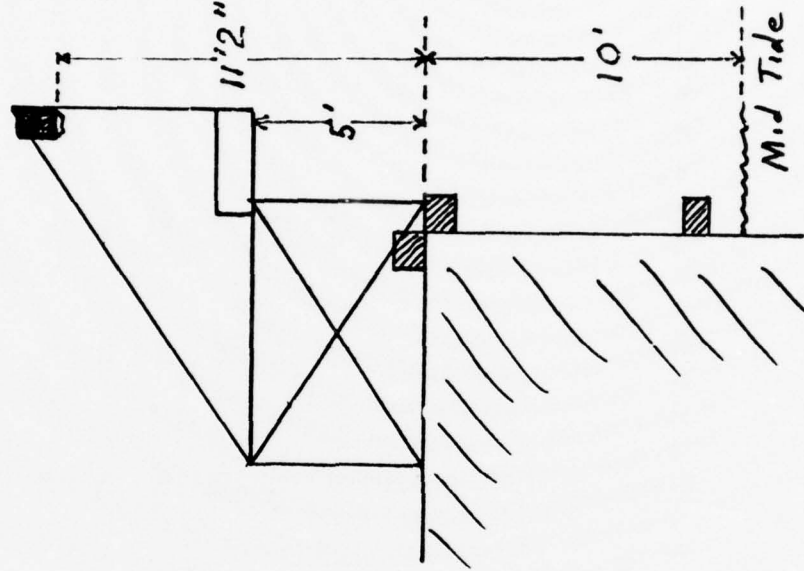
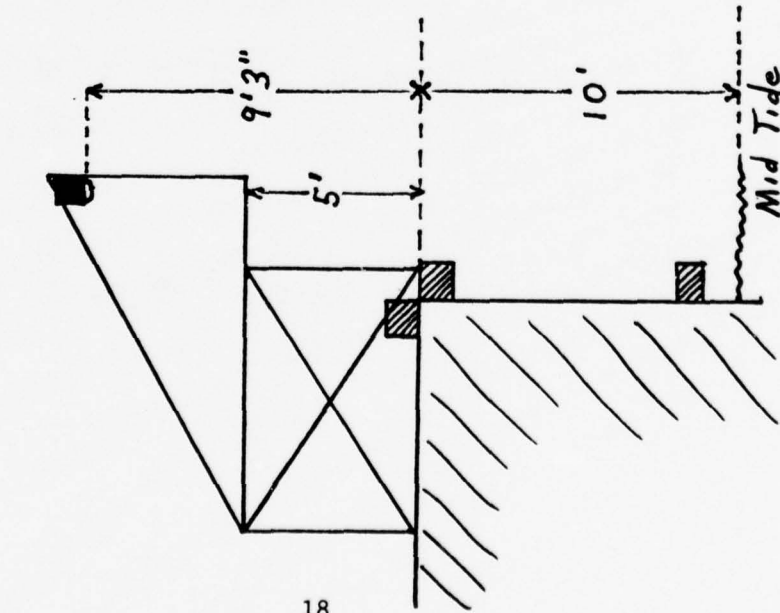

FIGURE 5. MODIFIED SENSOR PLATFORMS

At this time, additional problems were encountered with the line voltage supplying the sensors. Work had started on repairing the drydock area adjacent to the sensor locations and the work was requiring considerable electric power. It was observed that the line voltage at the Rambi sensors had decreased to 108 volts because of the power drain for construction at the drydock. It is not felt that the voltage drop was sufficient to produce signal drops of the magnitude observed.

#### 7.5 Verification of Sensor Operation Through Chemical Analysis of Surface Samples

To provide substantiation of reliable operation, it was required that surface samples be obtained and chemically analyzed. This was especially true because of the frequent presence of thin oil films which were not visible but were sufficient to produce a detection alarm. Samples were obtained by the on-site technician with Teflon collecting strips provided by the R&D Center Chemistry Branch. The Teflon strips were then sealed in sterilized sample bottles and returned to the R&D Center for analysis.

All samples were analyzed by fluorescence spectroscopy in the following manner:

a. 10 ml of spectroquality cyclohexane was added to the eight (8) ounce sample bottle container holding the Teflon collection strips. The cyclohexane was then shaken to insure that it had come in contact with all portions of the Teflon strips.

b. Approximately 4 ml of the cyclohexane was extracted and placed into a 1 cm quartz cuvette.

c. The fluorescent emission spectrum of the cyclohexane extract was then recorded at the following fixed conditions on a fully corrected MK-1 Farrand Spectro Fluorometer:

- (1) Excitation wavelength - 10 nm
- (2) Emission scan from 280 nm to 500 nm
- (3) Emission scan speed 50 nm/min
- (4) Emission slit - 1 nm

In recording the fluorescence emission spectra, the maximum fluorescence signal was normalized to 95 percent of scale by varying instrument gain. For the purpose of this report, the relative concentrations of the samples are described as high, medium, low and zero. Additionally, within each grouping, the samples are arranged as the type of oil present based on the characteristic shape of the fluorescence emission fingerprint. Within the thirty-three samples analyzed, there existed six basic types of oil spectra. Only 5 of the 33 samples could be considered to be oil free. Of the six types, Type 1 spectra is the most pronounced. Not only does it contain the same basic oil fluorescence fingerprints, but it contains the same erroneous spike which are non oil. These erroneous spikes are extremely strong within this group and probably are related to some non-petroleum fluorescent hydrocarbons. Table 5 is a presentation of the samples grouped in categories of concentration and type spectra. Table 6 is a summary of the samples and the corresponding Rambie sensor response. Figures 6 through 11 are typical spectra of each type encountered.

Table 6 lists 20 samples. Five samples were taken to verify a zero reference adjustment. Of these five samples, three showed the presence of oil. Because of this possibility, it is necessary that a water sample be taken whenever the Rambie sensor is adjusted for a clean water reference. It was attempted to avoid this problem by using a suspended pan of clean tap water as the reference surface. When this was done, the signals on channels 1 and 2 rose to over 12 volts saturating the amplifiers. As the sensor had to operate with maximum amplification when viewing a choppy surface a roundabout method was devised to balance the channels. First the amplifier gain was decreased to bring the signals on channels 1 and 2 out of saturation. The channels were then balanced to produce a zero signature. A pane of glass attenuator was introduced in the optical path. It reduced the channel 1 and 2 signal levels by approximately three volts but also changed the signature to +.8 volts. This indicated the glass absorbed energy differently at the two wavelengths. The amplifier gains were then increased to maximum and balanced to a +.8 volts to compensate for the pane of glass. The glass and pail of water were removed but the ratio went to more than 1 volt negative instead of zero. The sensor might have been affected by secondary reflections from the pan bottom or the compensation method for the glass attenuator might not have been accurate enough. Either way, it appears that to be effective the two channels must be balanced when viewing the actual surface to be monitored.

Samples 6, 7, 11, 27, 28, 29 and 30 verified proper sensor operation. However, samples 2, 5, 19, 20, 21 and 22 all showed the presence of oil when a visual sheen was observed but the sensor did not give an alarm response. There were only two samples (3 and 8) which showed no oil present at the same time the sensor was indicating oil. In the specific instances when samples were obtained, the sensors correctly detected the presence of invisible oil films five times, a visible sheen once, but did not detect verified visible sheens on six different occasions.

RELATIVE INTENSITY

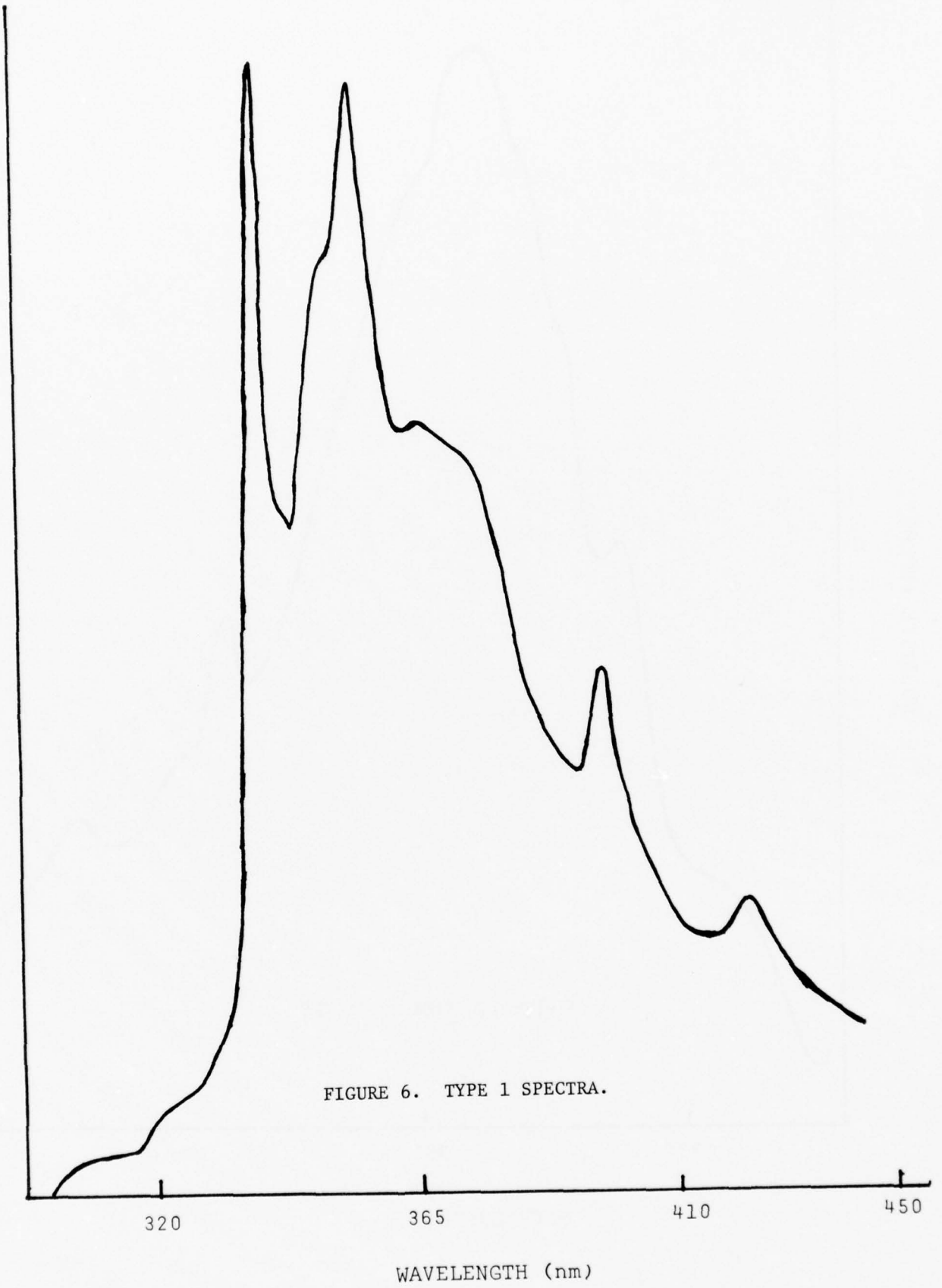

FIGURE 6. TYPE 1 SPECTRA.

RELATIVE INTENSITY

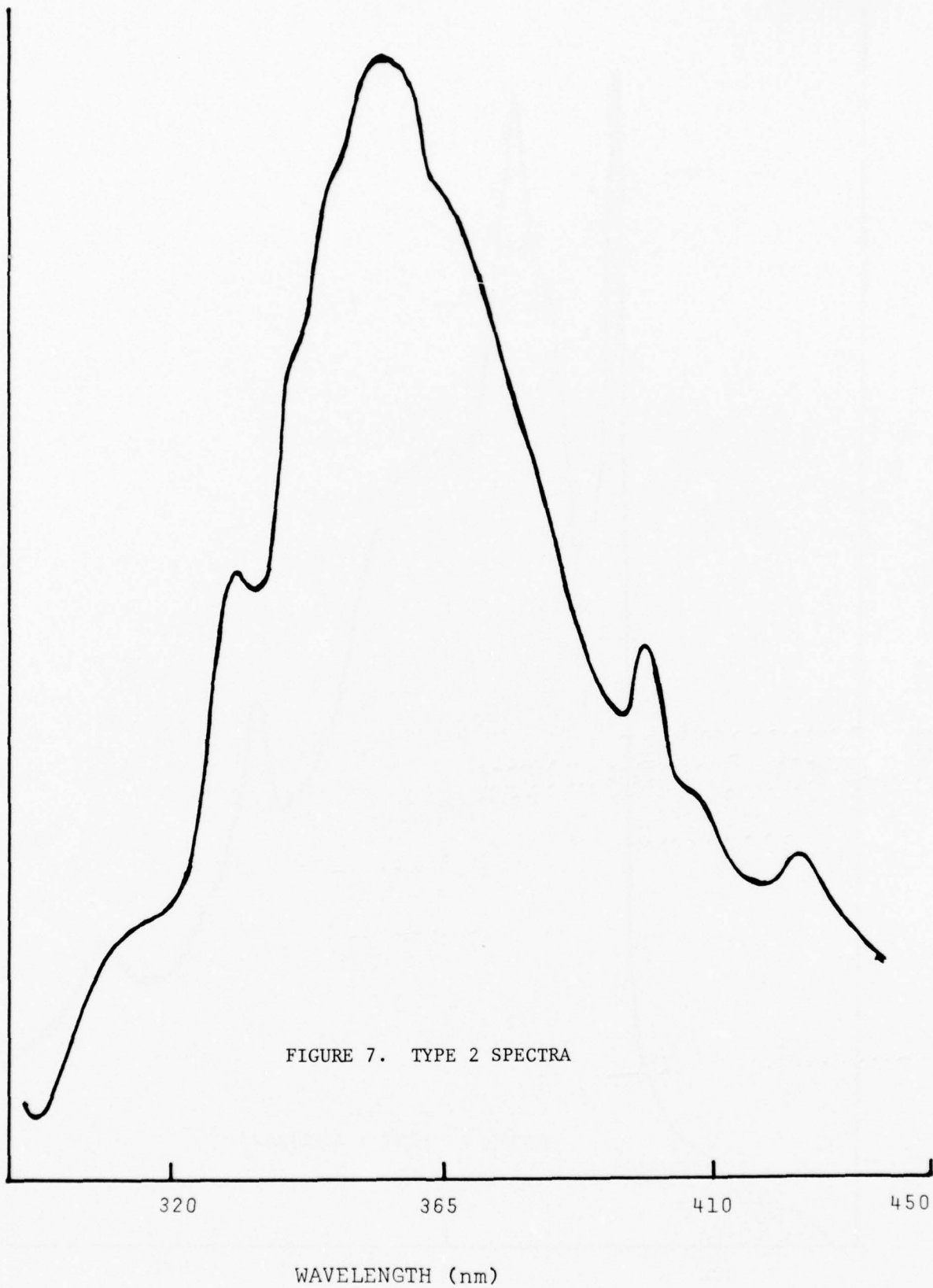

FIGURE 7. TYPE 2 SPECTRA

RELATIVE INTENSITY

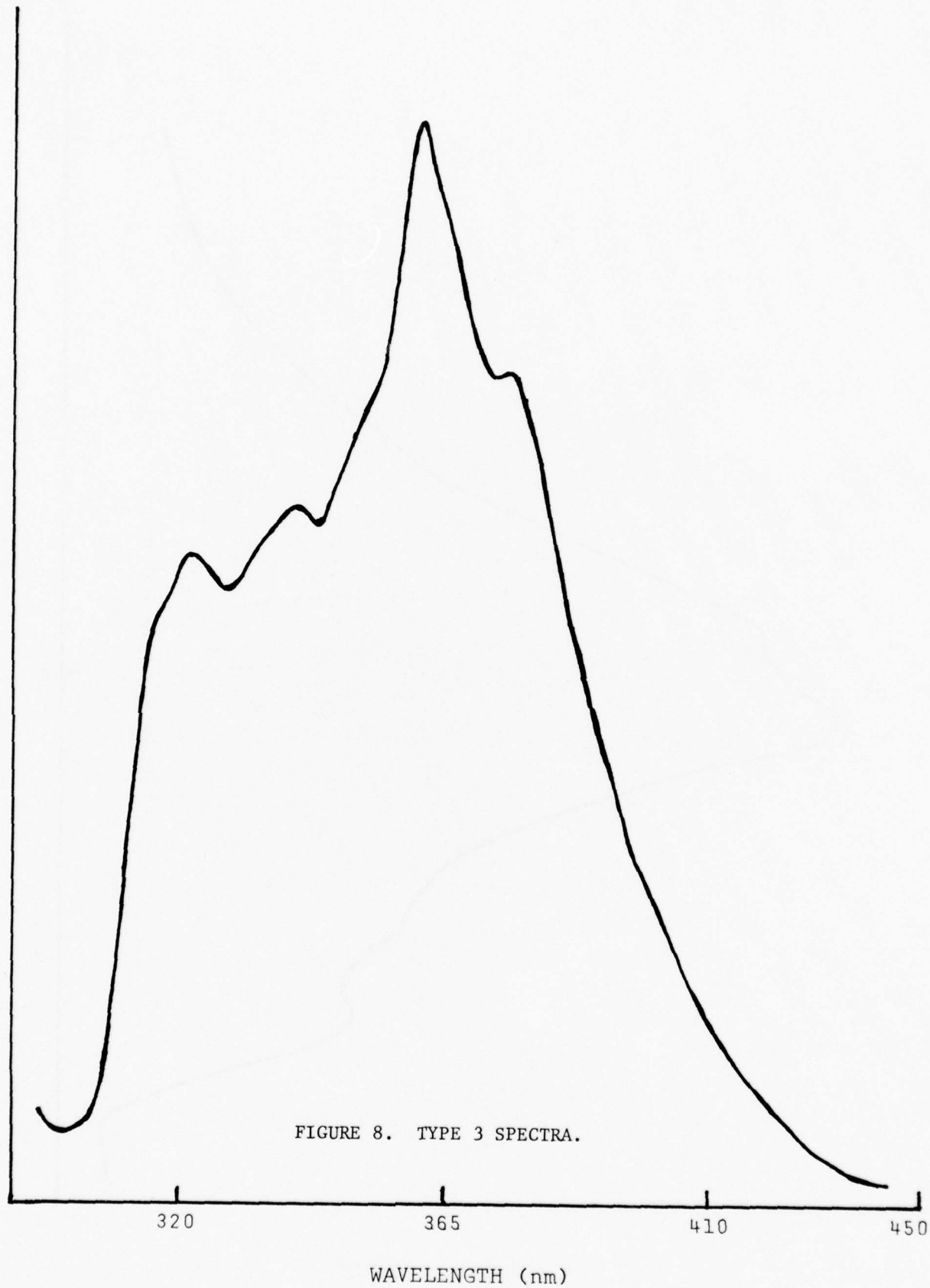

FIGURE 8. TYPE 3 SPECTRA.

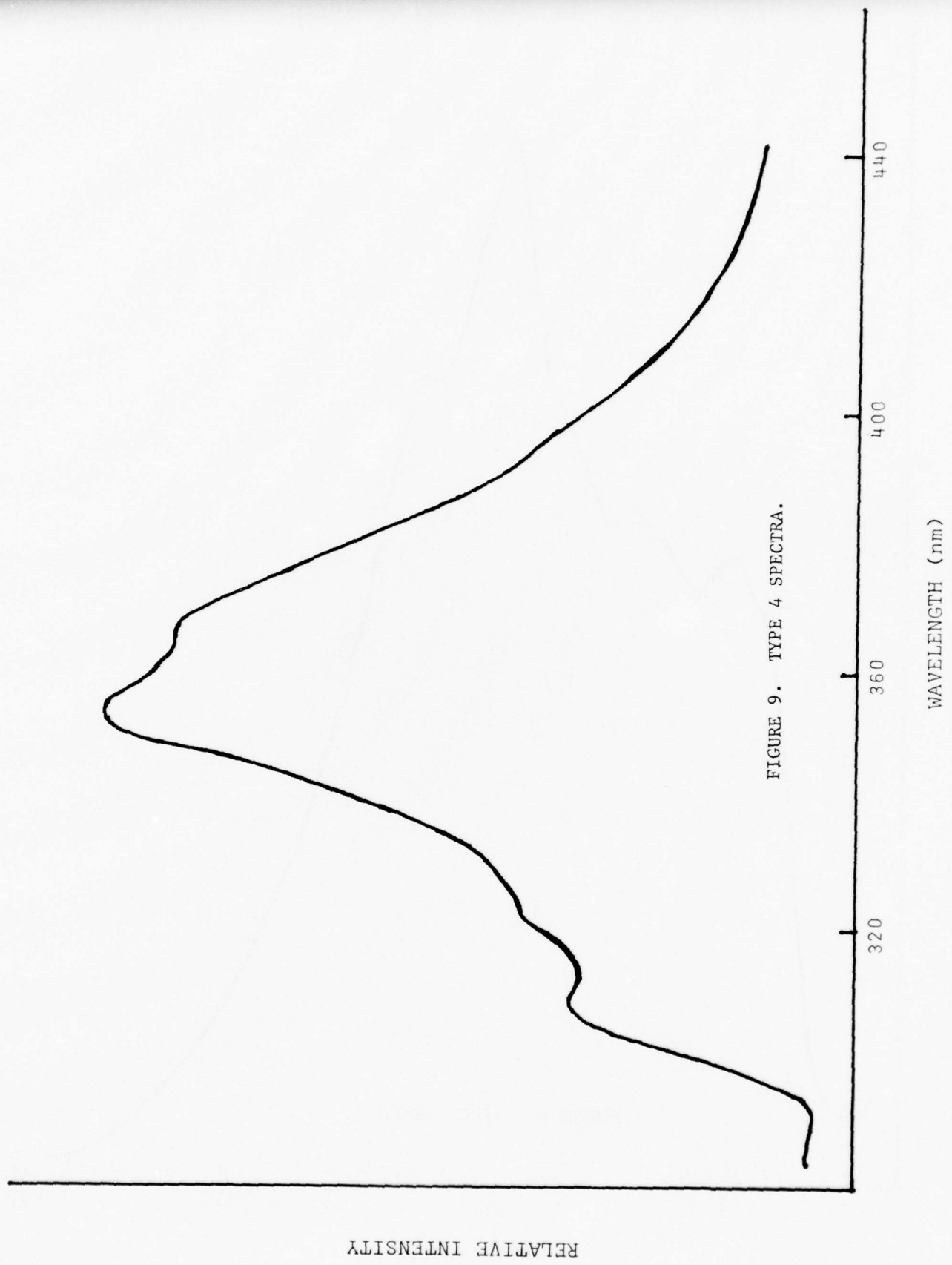

FIGURE 9. TYPE 4 SPECTRA.

RELATIVE INTENSITY

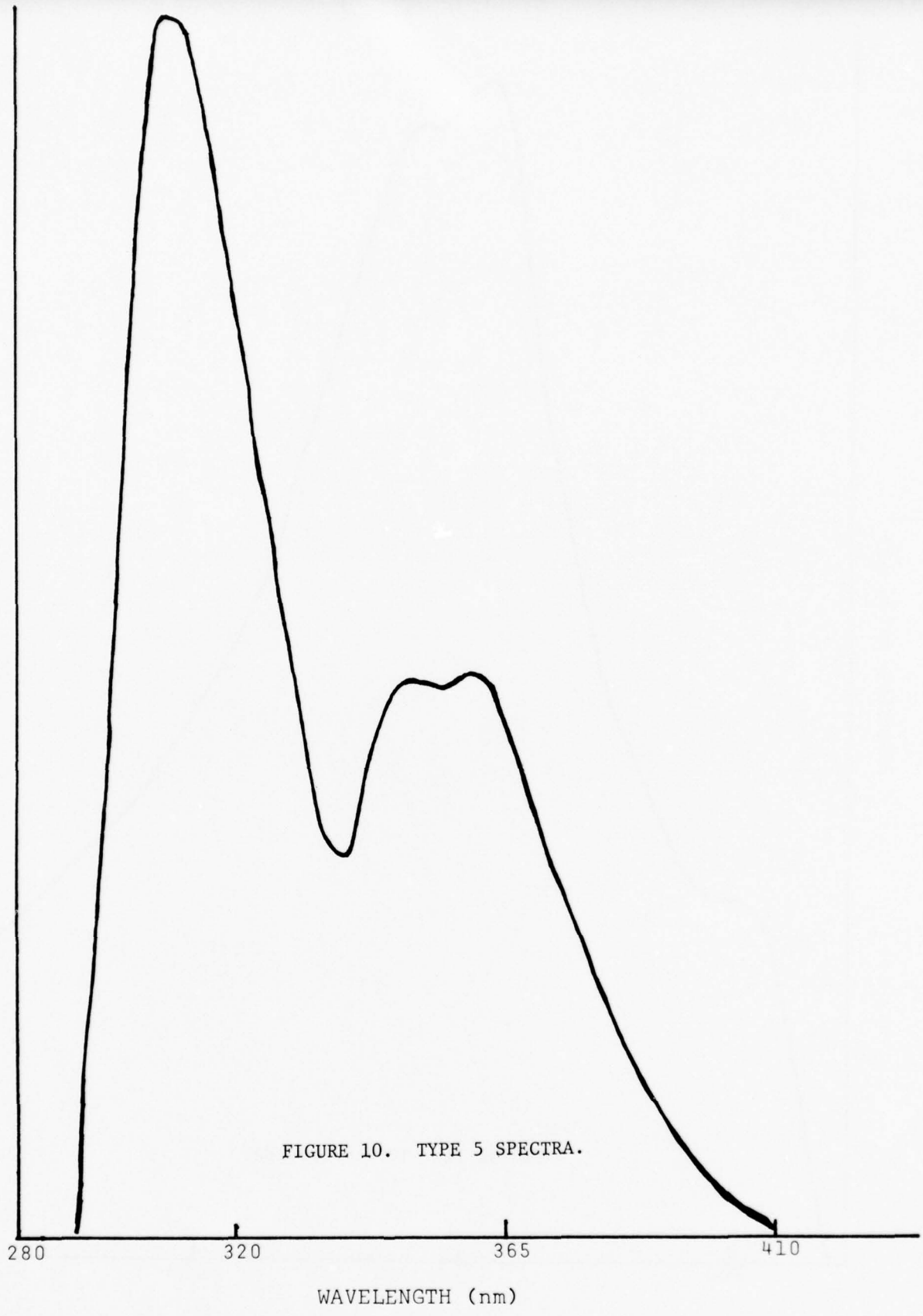

FIGURE 10. TYPE 5 SPECTRA.

RELATIVE INTENSITY

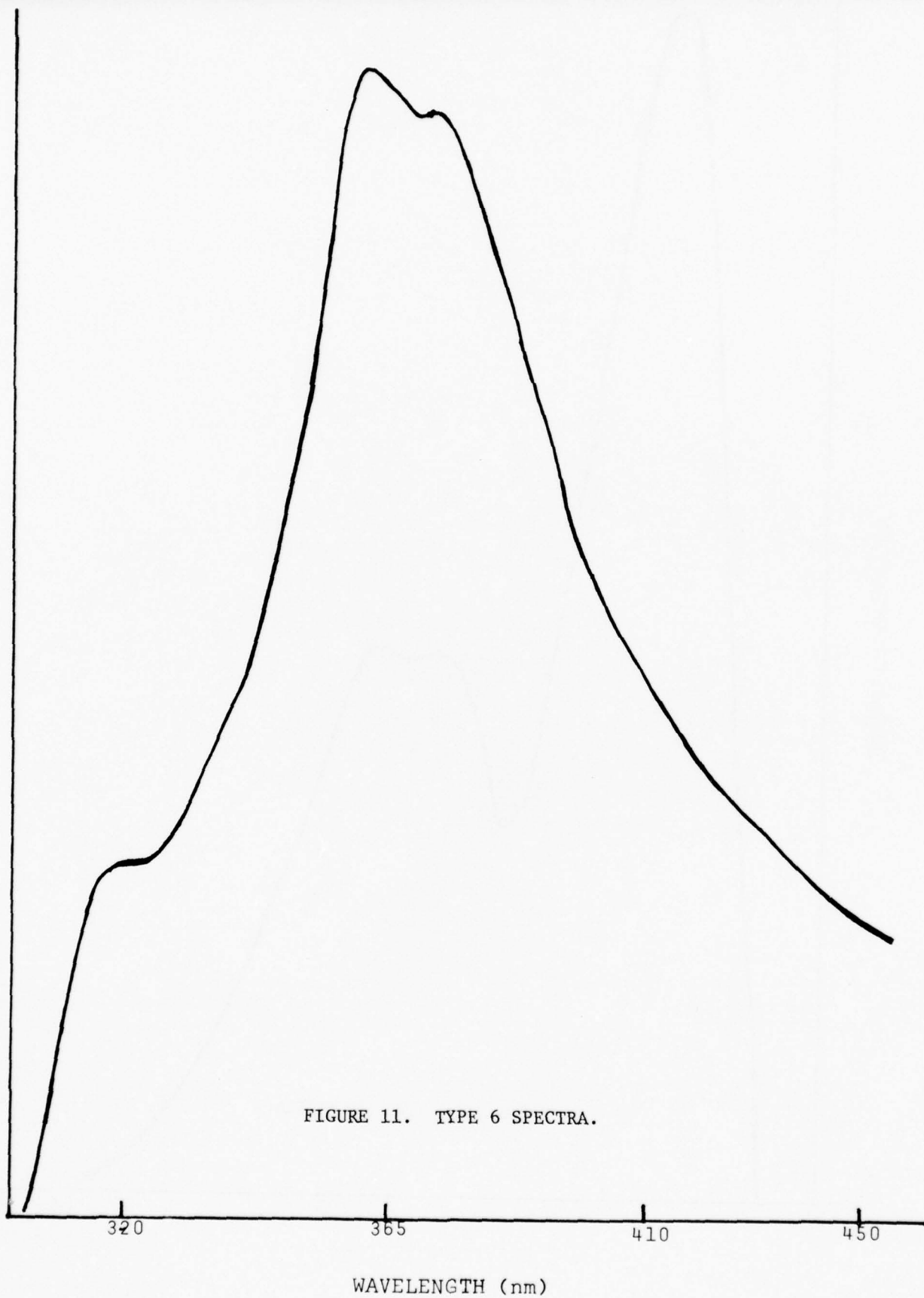

FIGURE 11. TYPE 6 SPECTRA.

TABLE 5  
 SUMMARY OF CHEMICAL ANALYSIS OF SURFACE SAMPLES  
 (Yes and No Indicate if Visible Oil was Present)

A. HIGH OIL CONCENTRATIONS

<u>Type 1 Spectra</u>	<u>Type 2 Spectra</u>	<u>Type 3 Spectra</u>	<u>Type 4 Spectra</u>
No. 12 - No	No. 26 - No	No. 22 - Yes	No. 1 - No
No. 18 - No			
No. 32 - No			
No. 27 - No			
No. 15 - No			

B. MEDIUM OIL CONCENTRATIONS

<u>Type 3 Spectra</u>	<u>Type 4 Spectra</u>	<u>Type 5 Spectra</u>	<u>Type 6 Spectra</u>
No. 5 - Yes	No. 2 - Yes	No. 24 - No	No. 23 - Yes
No. 20 - Yes			
No. 19 - Yes			

C. LOW OIL CONCENTRATIONS

<u>Type 1 Spectra</u>	<u>Type 2 Spectra</u>	<u>Type 3 Spectra</u>
No. 7 - No	No. 11 - No	No. 33 - No
No. 6 - No	No. 28 - Yes	No. 25 - No
No. 10 - No	No. 31 - No	No. 29 - No
No. 17 - No	No. 30 - No	No. 14 - Yes
No. 16 - No		
No. 21 - Yes		

D. ZERO OIL CONCENTRATIONS

No. 13 - No	No. 3 - No
No. 9 - No	No. 4 - No
No. 8 - No	

TABLE 6  
SUMMARY OF SAMPLES TAKEN TO VERIFY RAMBIE SENSOR OPERATION

<u>Sample Date</u>	<u>Sensor</u>	<u>Visual Observation</u>	<u>Sensor Alarm</u>	<u>Chemical Analysis</u>
1. 31 Oct	R2	No visible sheen - set 0 ref.	--	Oil A
2. 3 Nov	R2	Visible sheen	No	Oil B
3. 4 Nov	R2	No visible sheen	Yes	No oil
4. 11 Nov	R2	No visible sheen - set 0 ref.	--	No oil
5. 17 Nov	R1	Visible sheen	No	Oil B
6. 18 Nov	R1	No visible oil	Yes	Oil C
7. 19 Nov	R2	No visible oil	Yes	Oil C
8. 11 Dec	R1	Visible foam	Yes	No oil
9. 18 Dec	R1	No visible oil - set 0 ref.	--	No oil
10. 19 Dec	R2	No visible oil - set 0 ref.	--	Oil C
11. 19 Dec	R1	No visible oil	No	Oil C
19. 26 Jan	R2	Visible sheen	No	Oil B
20. 27 Jan	R2	Visible sheen	No	Oil B
21. 29 Jan	R1	Visible sheen	No	Oil C
22. 30 Jan	R2	Visible sheen	No	Oil A
26. 17 Feb	R2	No visible oil - set 0 ref.	--	Oil A
27. 19 Feb	R1	No visible oil	Yes	Oil A
28. 20 Feb	R1	Visible sheen	Yes	Oil C
29. 23 Feb	R1	No visible oil	Yes	Oil C
30. 23 Feb	R1	No visible oil	Yes	Oil C

Figures 12 through 17 are strip chart recording extracts that correspond to samples 2, 5, 8, 21, 29 and 30. Figure 12 shows no response to a visible sheen. Figure 13 shows a slight response, not enough to reach alarm threshold, to a visible sheen. Figure 14 shows a sharp (-.6 volt) response which must be considered a false alarm as chemical analysis showed no oil present. There was, however, some visible foam on the surface. Figure 15 shows no response to a visible sheen. Note the low signal levels on channels 1 and 2 (< 200 mv). Figures 16 and 19 show strong responses when no oil was visible. The analysis of the samples revealed the presence of oil.

Figure 18 shows the longest time, 54 minutes, a threshold level of -.40 was exceeded. A visible sheen was present the entire period.

FIGURE 12 - Rambie sensor strip chart recording showing no response to verified sheen. Sample #2 Channel 3 is signature value which is the logarithm of the Channel 1 to Channel 2 ratio. A clean water signature is 0.0 volts. If oil is detected the signature should decrease to from  $-.25$  to  $-.60$  volts depending upon the oil film thickness and type.

Self-test alarm

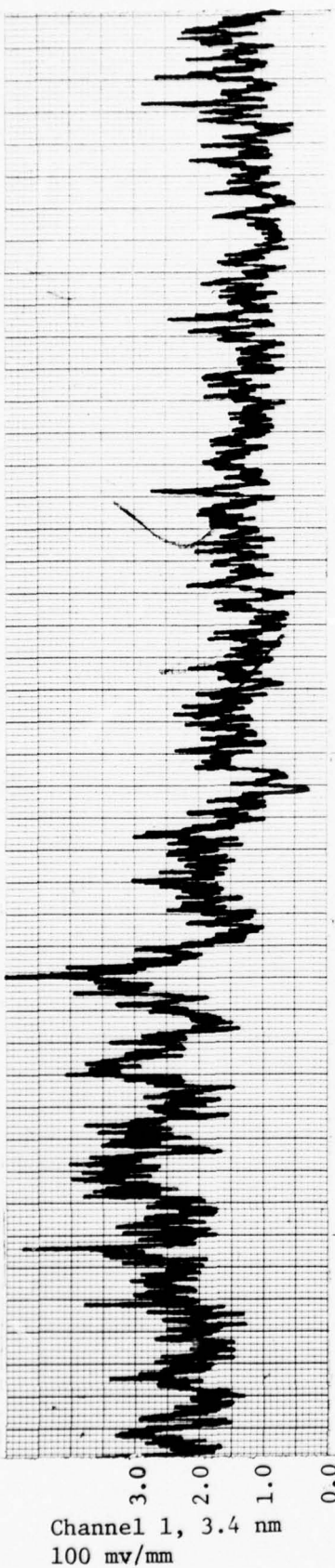

SALEM, NEW HAMPSHIRE, U.S.A.

DURATION

FIGURE 12. Rambi Sensor #2  
3 November 1975 - Sample #2  
Chart speed 0.5 cm/min  
Visible sheen but no response

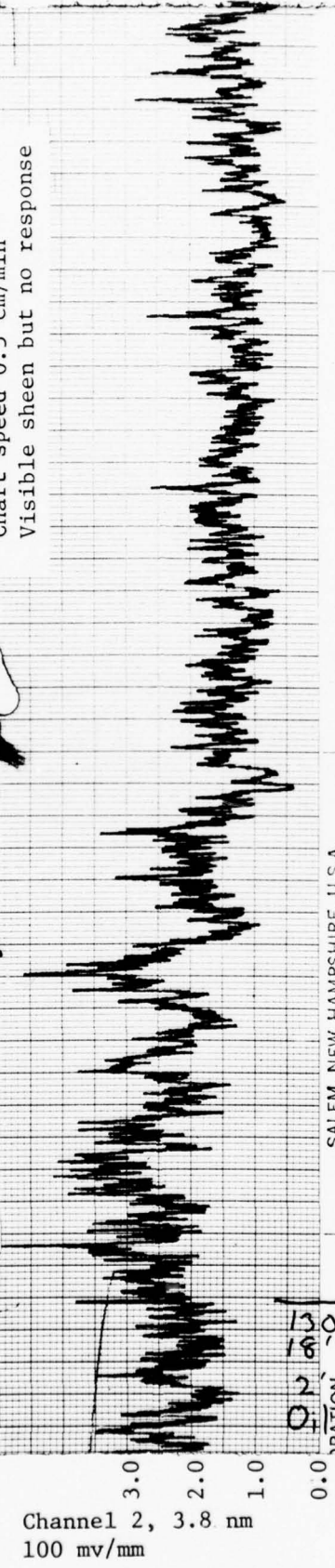

SALEM, NEW HAMPSHIRE, U.S.A.

DURATION

1300  
18'6"  
2' waves  
Oil is Present,  
Pic. #1x2  
Roll #5  
Oil Samp. #1

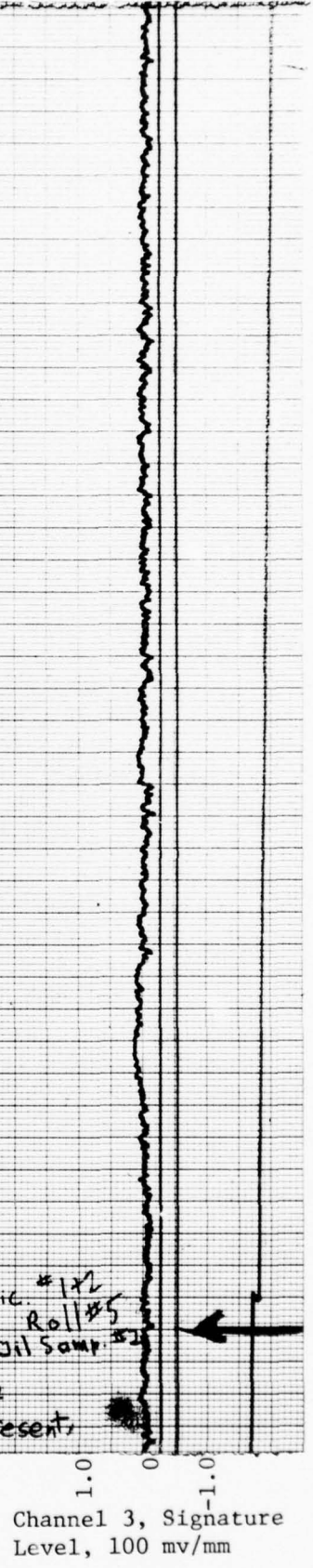

Oil alarm - none

FIGURE 13 - Rambie sensor strip chart recording showing a slight response, but not enough to reach alarm threshold, to a visible sheen. Sample #5 Channel 3 is ratio value.

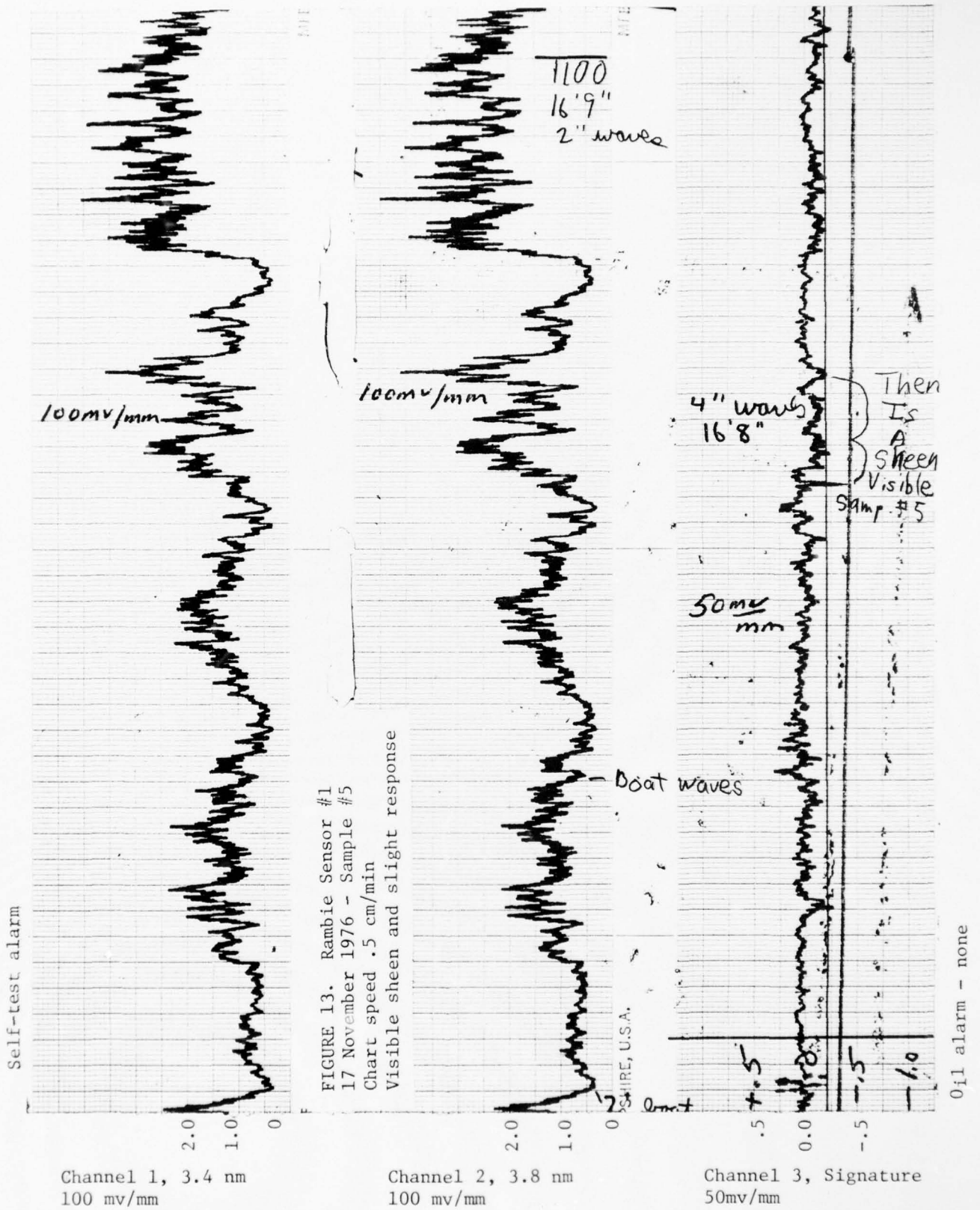

FIGURE 13. Ramble Sensor #1  
 17 November 1976 - Sample #5  
 Chart speed .5 cm/min  
 Visible sheen and slight response

FIGURE 14 - Rambie sensor strip chart recording showing strong response to Sample #8 which was shown to not contain any oil. Foam but no oil was visible. Sample #8 Channel 3 is ratio value.

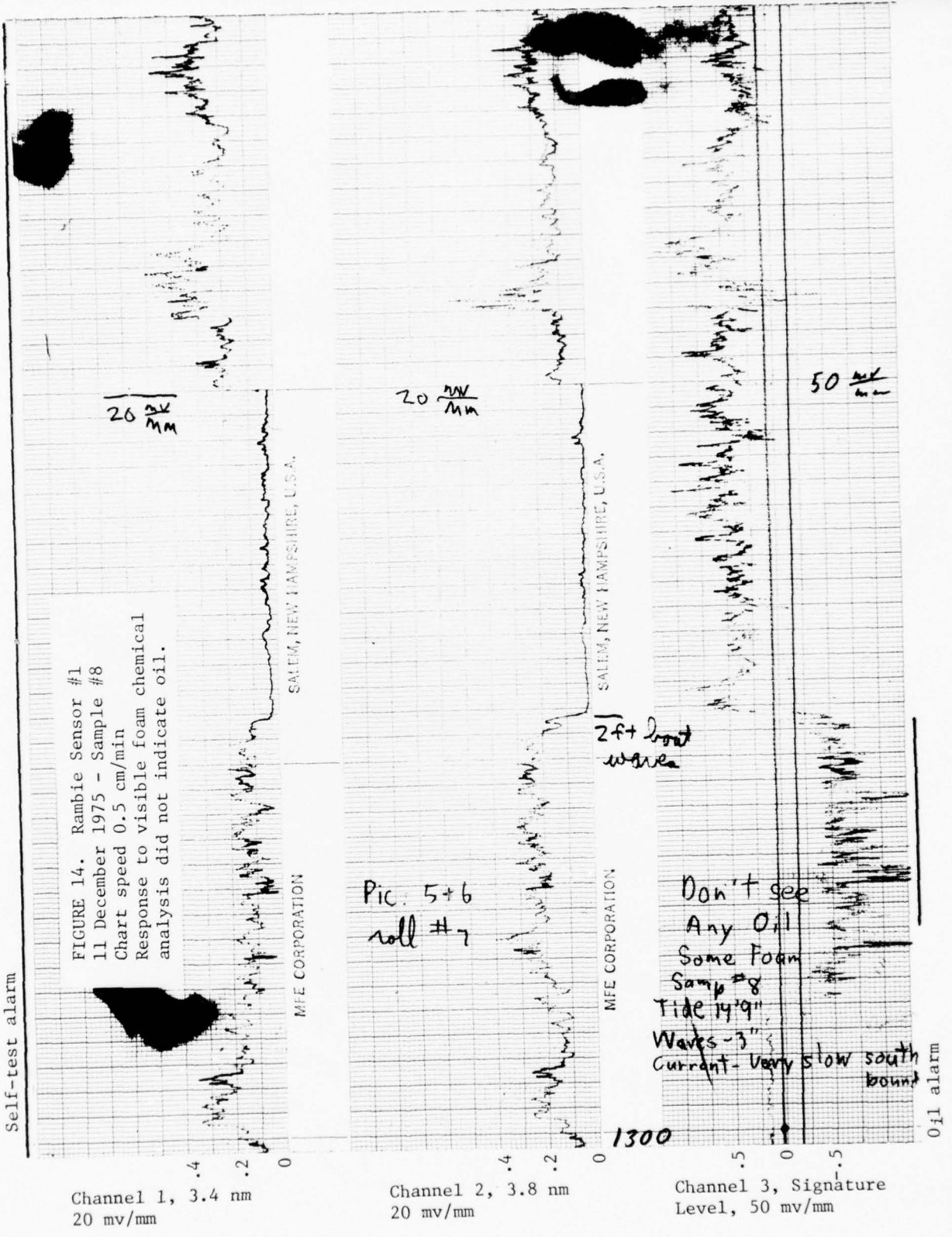

TABLE 10  
NUMBER OF ALARMS FOR VARIOUS THRESHOLDS AND TIME DURATIONS

FIGURE 15 - Rambe sensor strip chart recording  
showing no response to a visible sheen. Sample #21  
Channel 3 is ratio value.

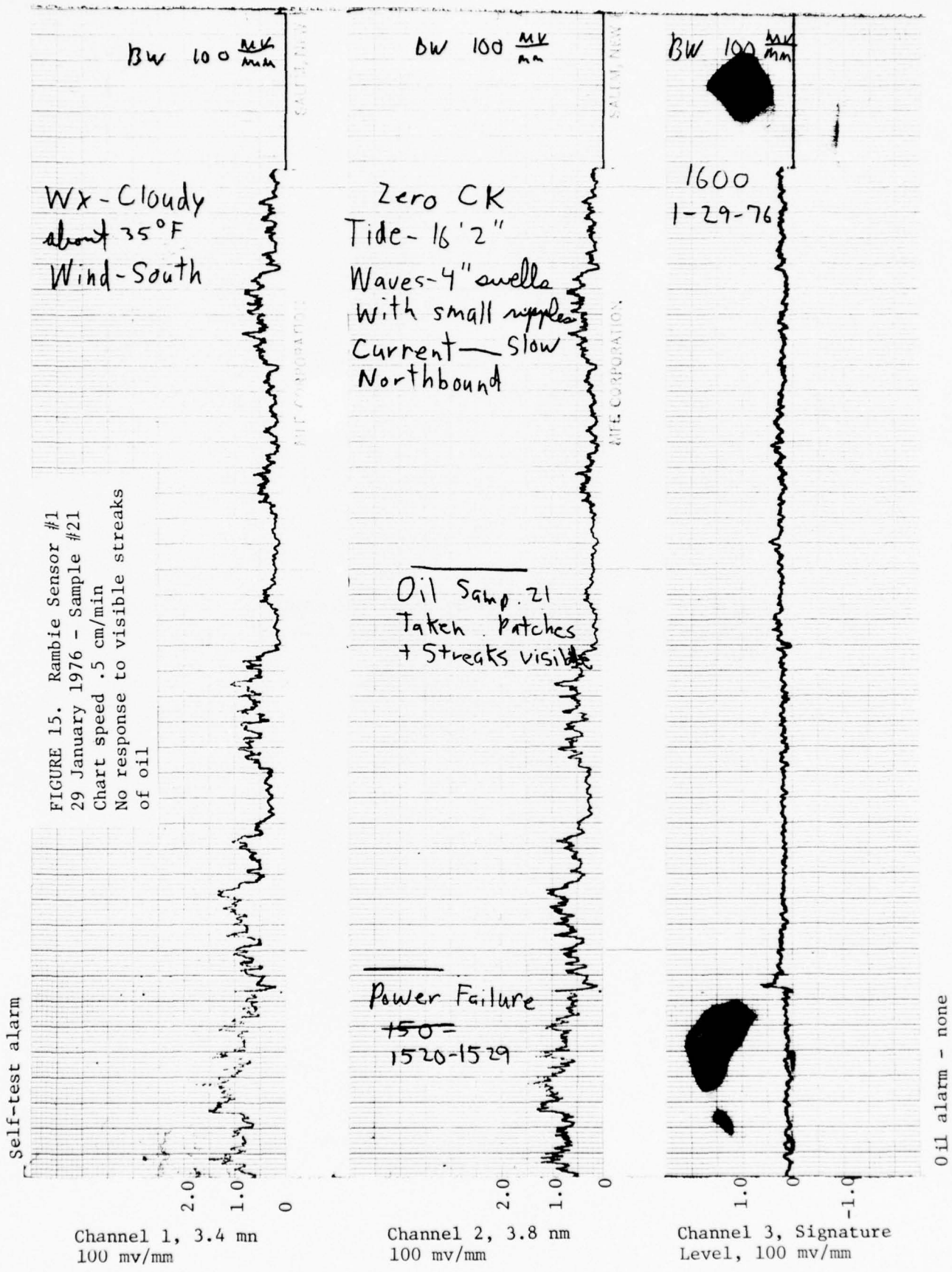

FIGURE 15. Rambi Sensor #1  
29 January 1976 - Sample #21  
Chart speed .5 cm/min  
No response to visible streaks  
of oil

Wx - Cloudy  
about 35°F  
Wind - South

Zero CK  
Tide - 16'2"  
Waves - 4" swells  
with small ripples  
Current - Slow  
Northbound

Oil Samp. 21  
Taken. Patches  
+ Streaks visible

Power Failure  
150 =  
1520-1529

1600  
1-29-76

Oil alarm - none

FIGURE 16 - Rambiie sensor strip chart recording  
showing strong response to invisible oil film  
Sample #29 Channel 3 is ratio value.



FIGURE 17 - Rambie sensor strip chart recording showing response to invisible oil. Sample #30 Channel 3 is ratio value.

Self-test alarm

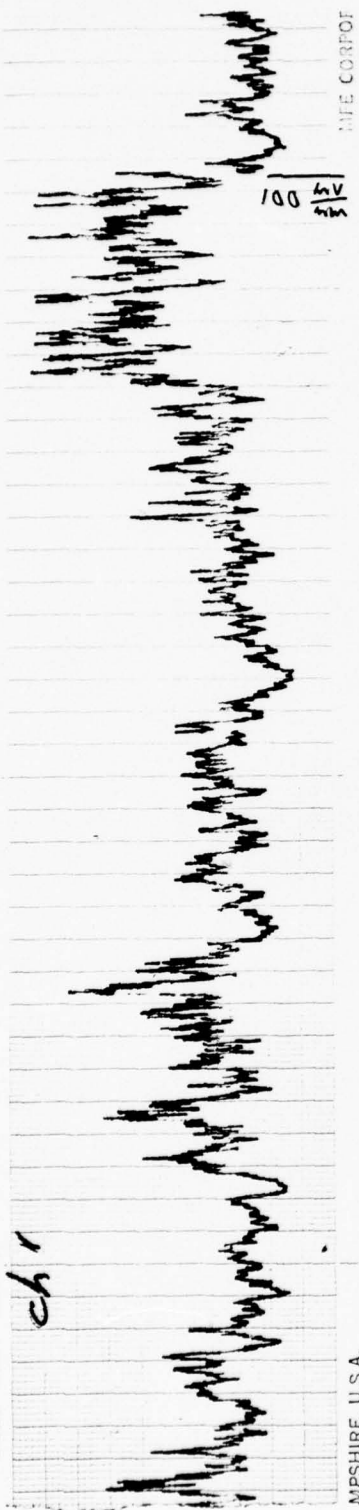

Channel 1, 2.0, 3.4 nm  
100 mv/mm



Channel 2, 2.0, 3.8 nm  
100 mv/mm

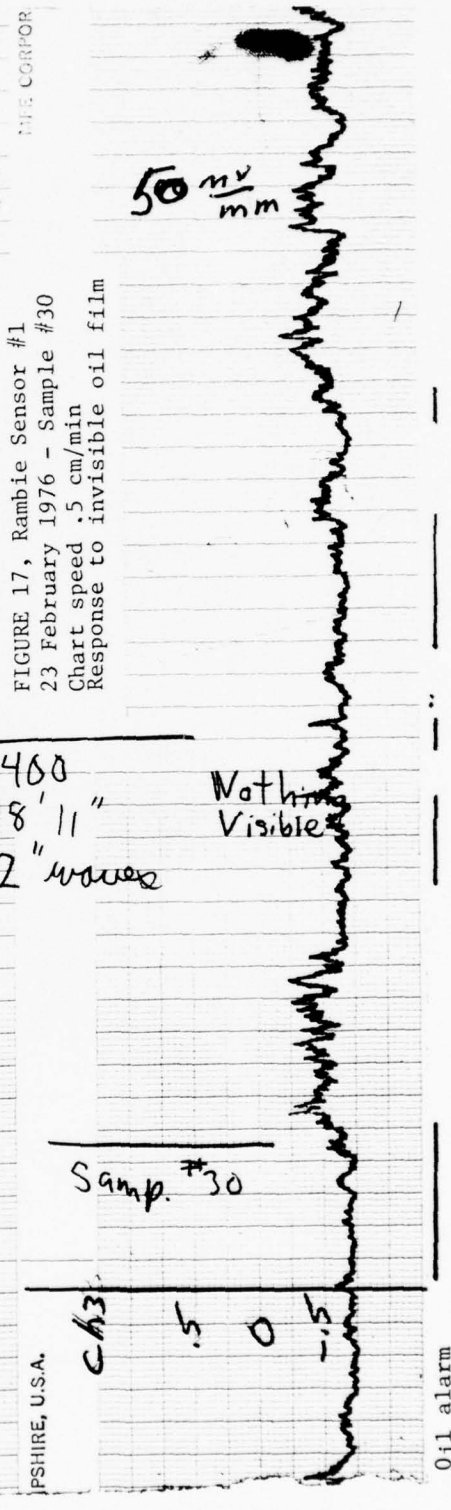

Channel 3, Signature Level, 50 mv/mm

FIGURE 17, Ramble Sensor #1  
23 February 1976 - Sample #30  
Chart speed .5 cm/min  
Response to invisible oil film

1400  
18' 11"  
2" waves

Nothing Visible

Sample #30

ch3

.5 0 -.5

Oil alarm

FIGURE 18 - Rambie sensor strip chart recording showing 54-minute response to a visible sheen on 27 January 1976. Channel 3 is ratio value.

Self-test alarm

FIGURE 18, Rambi Sensor #1  
27 January 1976  
Chart speed .5 cm/min  
54-minute response to a visible sheen

Channel 1, 3.4 nm  
100 mv/mm

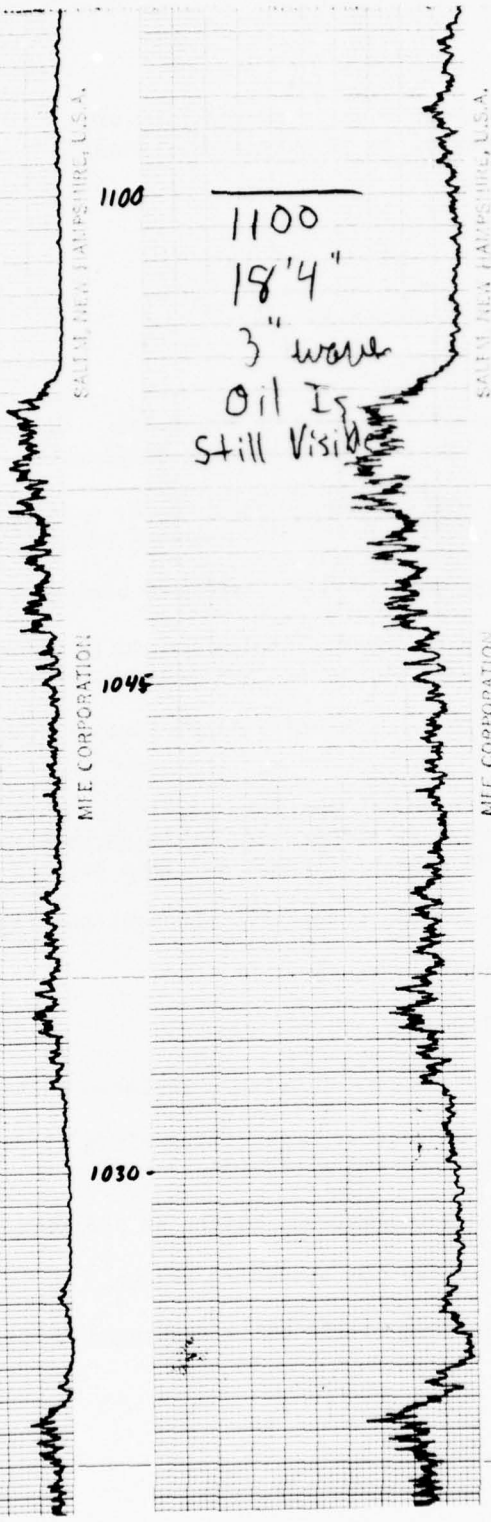

1100  
18'4"  
3" wave  
Oil Is  
still visible

Channel 2, 3.8 nm  
100 mv/mm

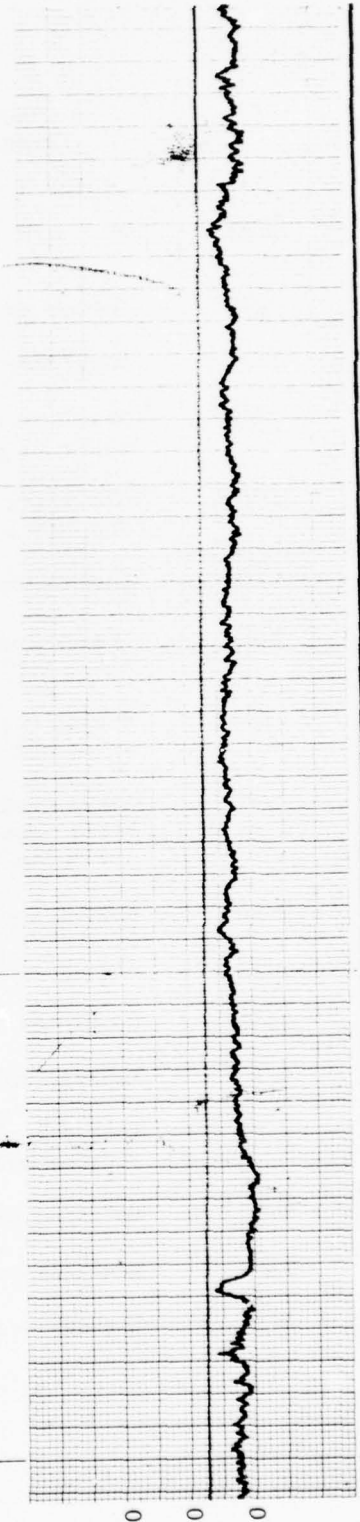

Channel 3, Signature  
Level, 100 mv/mm

Oil alarm

12" Boat Waves

TABLE 7  
A CHRONOLOGICAL SUMMARY OF PROBLEMS WITH  
RAMBIE SENSOR #1 IN OPERATIONAL PHASE

<u>Date</u>	
11/5	Sensor does not respond to oil.
11/7	Realignment completed.
11/10	Reset clean water signature to 0.0 volts. Oil alarm not working - replaced relay K2 but did not solve problem.
11/17	Oil alarm failure was traced to a faulty alarm circuit board. The board was replaced and alarm worked properly.
12/8	Battery voltage down to 93V - replaced batteries.
12/12	Sensor lost 180 voltage. Problem traced to failed resistor R14. Replaced R14 and sensor working properly.
1/5	Sensor not responding to oil. Alarm circuit board checked and found OK.
1/12	Alarm problem traced to improper seating of buffer circuit board even though it appeared to be in correctly. This prevented 60 Hz getting through to alarm board.
1/13	Sensor not responding correctly. Suspect an alignment problem.
1/14	Attempted to realign sensor.
1/15	Completed realignment.
1/16	Battery voltage down to 70 volts - replaced batteries.
1/29	Recorder clock discovered not working since 23 January. Battery was replaced and clock reset.
2/5	Modified platform to increase height an additional 9.5 feet.
2/9	Realigned sensor for new operating height.
2/19	Battery voltage down to 134 volts - changed battery.

TABLE 8  
A CHRONOLOGICAL SUMMARY OF PROBLEMS WITH  
RAMBIE SENSOR #2 IN OPERATIONAL PHASE

<u>Date</u>	
11/10	Lost +15 volts
12/1	Sensor doesn't respond to oil. Battery voltage down to 131 volts. Replaced batteries but still does not work.
12/8	Discovered faulty wire connecting the two 90-volt batteries in series. Replaced the wire and sensor now working.
12/17	Sensor platform was modified.
12/18	Sensor realigned using suspended pan of fresh water method.
1/14	Platform damaged by barge docking at night. Warning lamp had been out due to a power failure. Only minor structural damage but again indicates vulnerability of pier-mounted sensors.
1/15	Repaired damaged platform.
1/16	Battery voltage down to 109 volts - replaced battery.
2/9	Modified platform to increase sensor height.
2/18	Self-test alarm fluctuating rapidly all day because of low channel 1 and 2 signal levels.

TABLE 9  
SUMMARY OF BATTERY VOLTAGE LEVELS FOR RAMBIE SENSORS #1 AND #2

<u>Date</u>	<u>Sensor 1 Voltage</u>	<u>Date</u>	<u>Sensor 2 Voltage</u>
31 Oct	160.2	31 Oct	172.3
21 Nov	130		146
1 Dec	111		133
2 Dec			131-180 new battery
8 Dec	93-181 new battery		168
22 Dec	147		150
5 Jan	121		131
13 Jan	111		119
16 Jan	99		112
19 Jan	70-178 new battery		109-174 new battery
21 Jan	160		160
28 Jan	150		151
2 Feb	141		146
19 Feb	134 changed battery- 177		133
23 Feb			128-185

## 7.6 Reliability for Unattended Operation

The field test indicated there would be definite problems employing this particular sensor in extended unattended operation as part of a Coast Guard-maintained harbor surveillance system. Both Rambi units experienced numerous electronic failures and periods of optical alignment difficulties. A chronological record of problems with the two sensors during the operational phase of the evaluation is presented in Tables 7 and 8.

Many of the problems encountered required electronic troubleshooting methods which were beyond the resident technician's capabilities. The R&D Center test officer made 11 separate trips to Bayonne, for a total of 22 days, primarily to repair and/or adjust the alignment of the Rambi sensors. Sensor #1 was inoperative for one cause or another eight separate times for a total of 22 days. Sensor #2 was inoperative for five separate times for a total of 11 days.

The replacement of the 90-volt batteries was a continuing problem. Rather than the nearly seven months estimated useful life, it was necessary to replace the batteries almost every seven weeks. Although it is not difficult to insert a new set of batteries, it does require sending a man to the site to effect the change. This could be a disadvantage if a monitoring system was composed of several sensors at widespread locations. Table 9 presents some data on the observed battery lifetime. The rapid decrease in voltage output was probably accelerated by the winter weather conditions encountered. Temperature levels remained below freezing for much of the evaluation period.

## 8.0 DATA ANALYSIS FOR WRIGHT AND WRIGHT OIL FILM MONITOR

Operation of the Wright and Wright Oil Film Monitor is affected by similar characteristics and situations which control the use of the Rambi sensor. These items again are:

- a. Oil alarm time delay
- b. Oil alarm threshold setting
- c. Effects of background oil levels
- d. Effects of tidal height variations
- e. Verification of operation through chemical analysis of surface samples
- f. Sensor reliability for unattended operation

### 8.1 Oil Alarm Time Delay

The Wright and Wright Oil Film Monitor is equipped with three response times for its ratio calculation. They are 10, 30 and 100 seconds. These time elements do not indicate the time of delay from introduction of oil to activation of the oil alarm, but rather the time required for the analog signal to reach one time constant (approximately 63 percent) of its final value. Longer time delays, which would be required to eliminate alarms for small patches of oil, would have to be installed with external delay circuits. In the Bayonne test, the ratio channel output was recorded on a chart recorder and the data could be analyzed to determine how many alarms would have been initiated at various time delays and threshold levels. A summation of the data is presented in Table 10.

Table 10 does illustrate clearly that the sensor will respond to oil in its field of view. Note the 3.5 volt threshold entries. Of the 40 times this threshold level was exceeded in over 1100 hours of operation, 27 instances occurred between 0800 and 1600 on the 27th of January 1976. This period accounted for 6 of the 7 alarm durations over 20 minutes. The threshold was exceeded continuously for instances of 24, 72, 30, 24, 28 and 204 minutes. Figure 19 is a strip chart recording showing the period of the 204 minute alarm. This was the longest continuously recorded alarm for the entire field test. Figure 18 is a strip chart recording from Rambi sensor #1 for the same time period. It recorded a continuous alarm for 54 minutes. This was also the longest continuous instance a Rambi sensor exceeded a -.40 threshold.

A visible oil sheen was visible throughout the day on 27 January 1976. However, it was foggy much of the day and the thin sheen was difficult to see. It was not until the data were analyzed that it was determined that this period was actually the only one on which an actual oil slick of considerable extent was detected. A discussion of the incident is included in Section 9.0 of this report.

### 8.2 Oil Alarm Threshold Setting

The oil alarm threshold setting is critical to the number of alarms initiated. Prior to installation, the Oil Film Monitor was adjusted and the clean water ratio channel reading determined to be 1.87 volts. An increase of this reading to over 2.2 volts would indicate the presence of oil. The magnitude of the increase above 2.2 would depend upon the specific petroleum product in the field of view. Levels of 2.6 and 3.5 volts were selected for alarm tabulation. Table 10 shows the drastic decrease in the number of alarms which would have been recorded from using the higher threshold. Most

TABLE 10  
 NUMBER OF ALARMS FOR VARIOUS THRESHOLDS AND TIME DURATIONS  
 FROM 1132 HOURS OF OPERATION OF WRIGHT AND WRIGHT SENSOR

Alarm Threshold = 2.6 volts

<u>Alarm Duration</u>	<u>Total Alarms</u>
2 mins. to 5 mins.	136
5 mins. to 10 mins.	53
10 mins. to 20 mins.	31
over 20 minutes	28

Alarm Threshold = 3.5 volts

<u>Alarm Duration</u>	<u>Total Alarms</u>	<u>Alarms on 27 January 1976</u>
2 mins. to 5 mins.	17	8
5 mins. to 10 mins.	10	7
10 mins. to 20 mins.	6	6
over 20 minutes	7	6

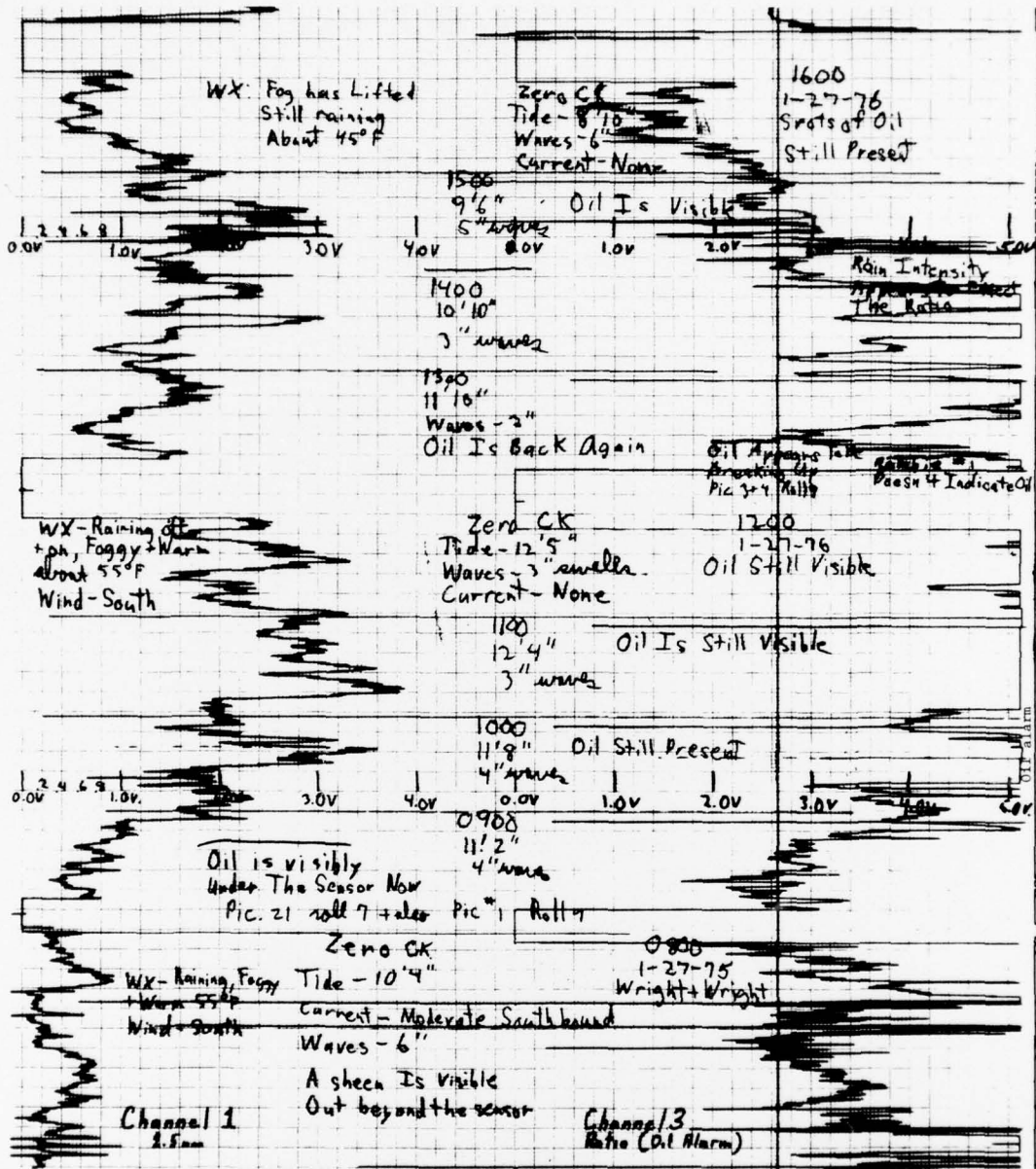

FIGURE 19 - Wright and Wright sensor strip chart recording showing 204-minute response to a visible sheen on 27 January 1976. 1 cm = 24 min. Note oil alarm indicated from 0900 to 1224.

of the readings between 2.6 and 3.5 were because of the presence of background oil. These events were filtered out by using a 3.5 threshold value but this also would eliminate visible sheens for some other petroleum products. Figure 20 is an extract of a strip chart recording of the sensor's response to a specific visible sheen from an unknown oil type. Note the signal level peaks at over 5 volts. Unfortunately, all oils do not produce such large ratio values.

### 8.3 Effects of Background Oil Level

The Wright and Wright sensor does not have to have its two wavelength channels balanced to a 0.0 reading for clean water as the Rambi sensor does. For this reason, the oil background problem is not such a serious one. In the laboratory, prior to installation at the Bayonne test site, the sensor alarm channel, channel 3, was indicating 1.87 volts when viewing clean fresh water. At this level, it was determined that an increase to 2.2 volts would indicate the presence of surface oil film. When the sensor was installed at the test site, channel 3 signal levels climbed to 2.2 volts and remained at that level just from the background oil level of surface water. No oil film was visible. As a visible sheen moved under the sensor, the channel 3 signal level increased dramatically to over five volts. Thus the alarm threshold could be set high enough, say 3 or 3.5 volts, to eliminate the effects of most background oil levels. However, it does not appear that there is a linear relationship between the increase in signal level from 2.2 volts to 5 volts and oil film thickness. Rather the level increases abruptly from low background conditions to visible sheen conditions for some petroleum products. For other petroleum products, the ratio level might not increase above 2.5 volts or so. Thus the background problem cannot be solved easily by just raising the threshold level to 3.5 or 4.0 volts. This would eliminate alarms for invisible oil films for some oils but it might preclude alarms for visible sheens of other oils. Additional detailed experiments would have to be conducted to determine the ratio levels produced by visible sheens of most petroleum products that could be spilled in the water. The optimum threshold would be the highest that would still detect each type of oil. It is doubtful if this value would be high enough to eliminate alarms for invisible films of other oils.

### 8.4 Effects of Tidal Height Variation

The Wright and Wright sensor was initially installed only 9.2 feet above mean water. However, no variation in the alarm channel signal level was observed because of the nearly six-foot tidal cycle encountered. It appears that the additional illumination provided by the 500-watt lamp, the use of automatic gain control, and the design which employs a single time shared amplifier with no optical beamsplitter, all work to make the alarm channel output steady over the six-foot tidal ranges.

### 8.5 Verification of Wright and Wright Sensor Operation Through Chemical Analysis of Surface Samples

Eight samples were taken and the results are listed in Table 11. If the alarm threshold was set at 3.5, only three cases (samples 14, 17, 21) would have initiated alarms. In all three cases, chemical analysis

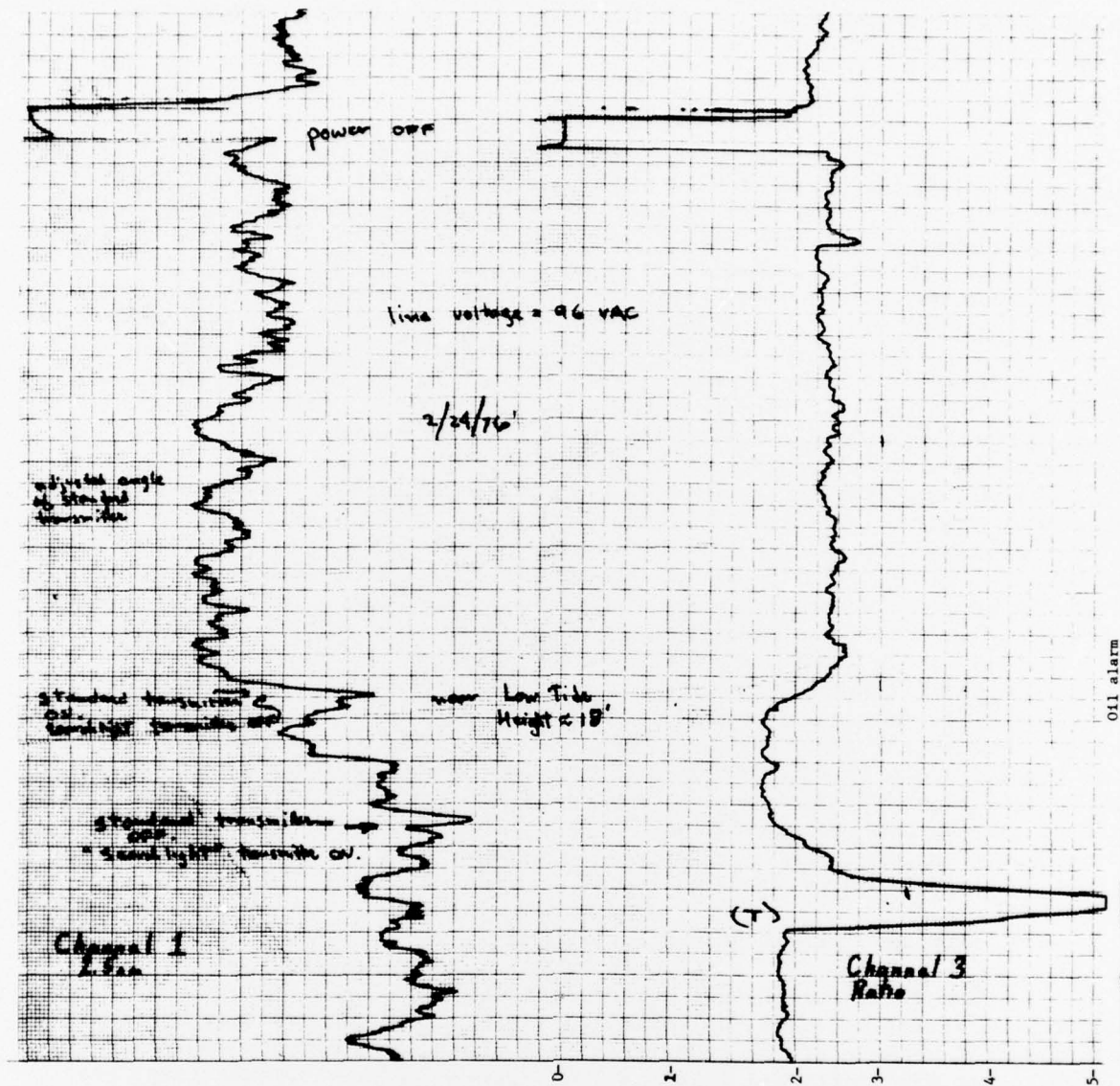

FIGURE 20. Wright and Wright sensor response to a visible sheen. Speed 10 mm = 2 minutes. 24 February 1976.

TABLE 11  
 SUMMARY OF SAMPLES OBTAINED TO  
 VERIFY WRIGHT AND WRIGHT SENSOR OPERATION

<u>Sample</u>	<u>Date</u>	<u>Sensor</u>	<u>Visual Observation</u>	<u>Alarm Channel</u>	<u>Chemical Analysis</u>
13	14 Jan	W	No visible oil	2.5	No oil
14	20 Jan	W	Visible streaks	5.0	Oil C
15	20 Jan	W	No visible oil	2.5	Oil A
16	21 Jan	W	No visible oil	2.4	Oil C
17	22 Jan	W	No visible oil	5.0	Oil C
18	26 Jan	W	No visible oil	3.4	Oil A
21	29 Jan	W	Visible streaks of oil	5.0	Oil C
25	11 Feb	w	White particles visible	2.5	Oil C

FIGURE 21 - Wright and Wright sensor strip chart recording showing sharp response to visible oil streaks. Sample #14.

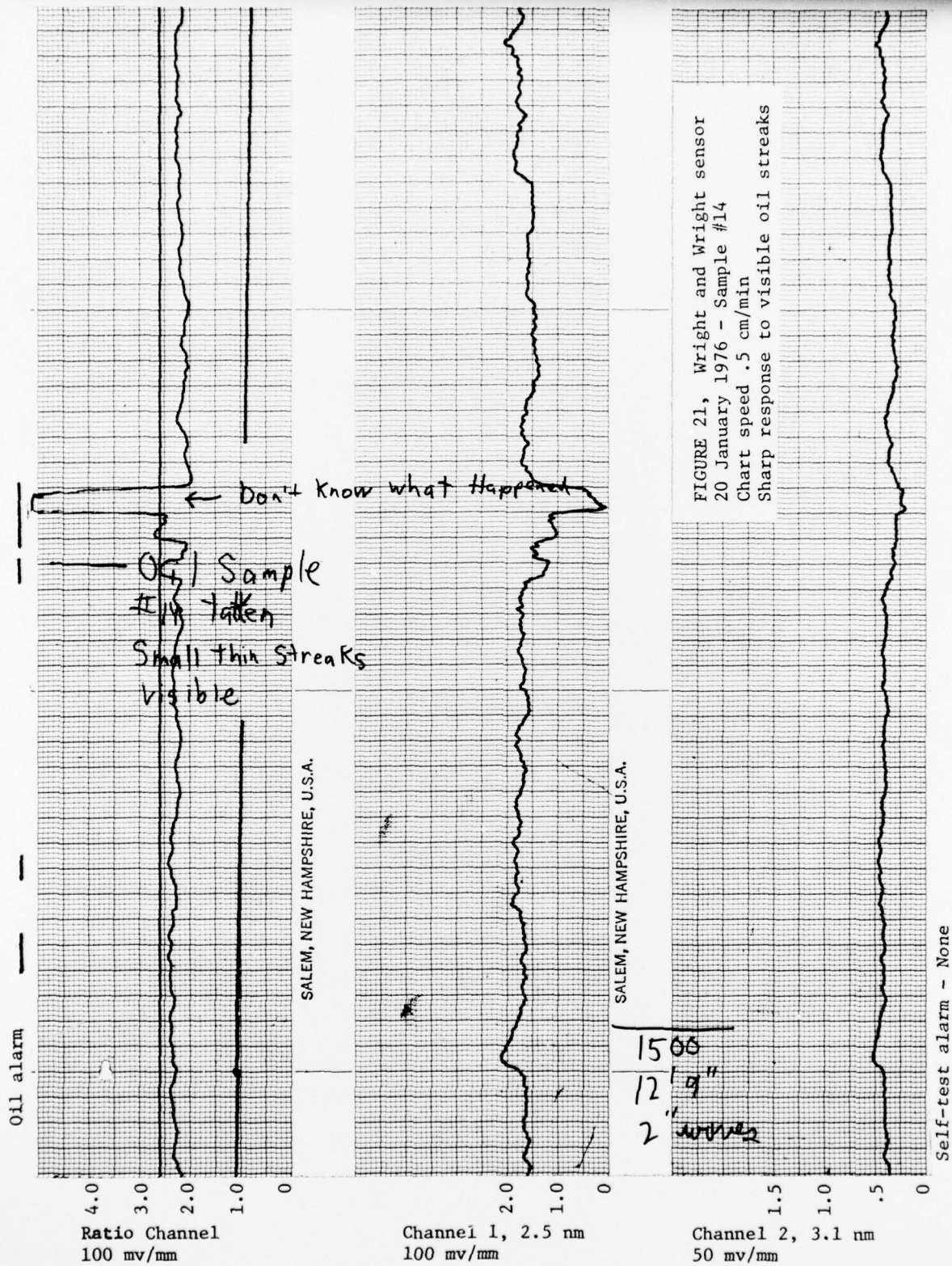

FIGURE 22 - Wright and Wright sensor strip chart recording showing sharp responses to invisible oil film. Sample #17.

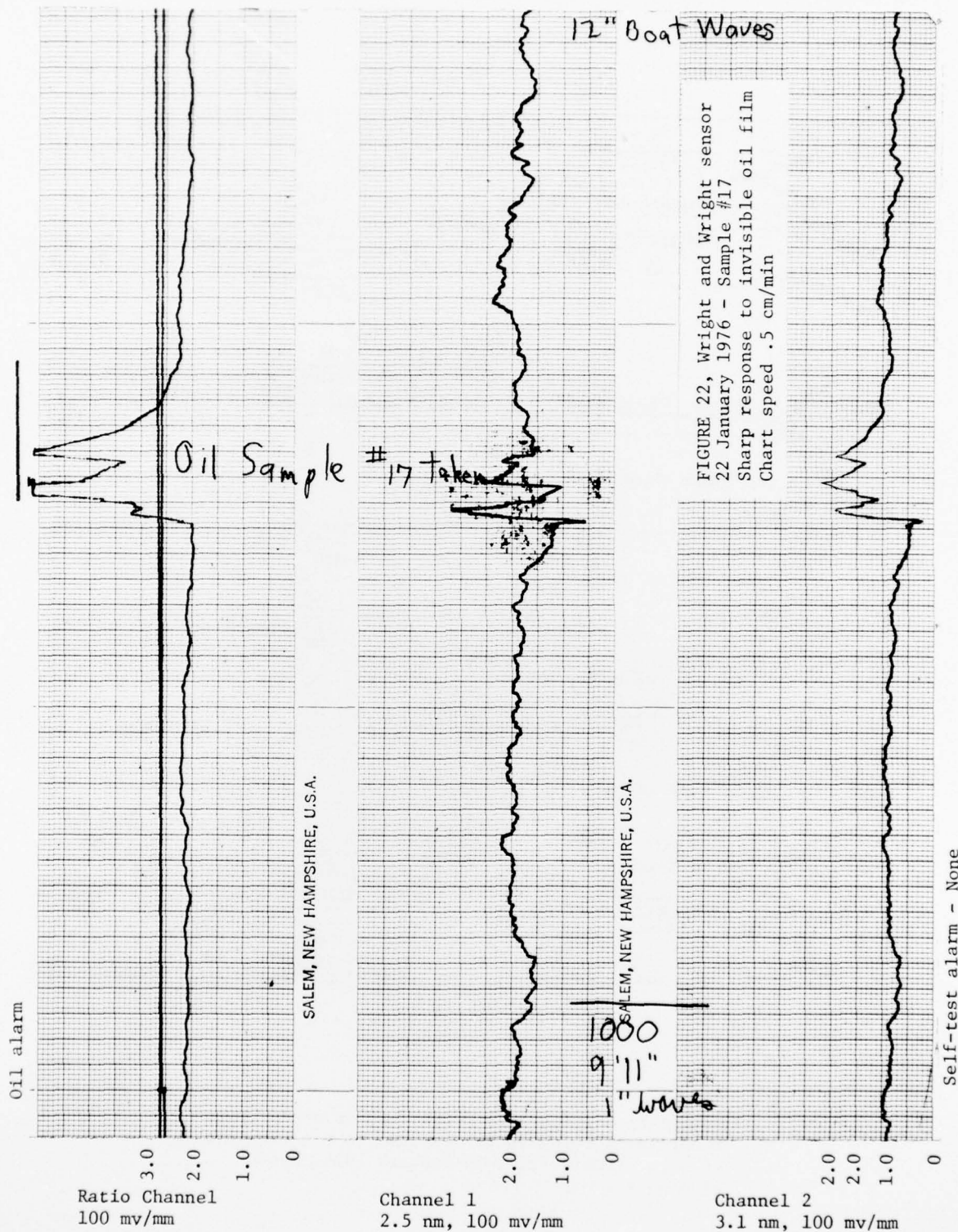

FIGURE 22, Wright and Wright sensor  
 22 January 1976 - Sample #17  
 Sharp response to invisible oil film  
 Chart speed .5 cm/min

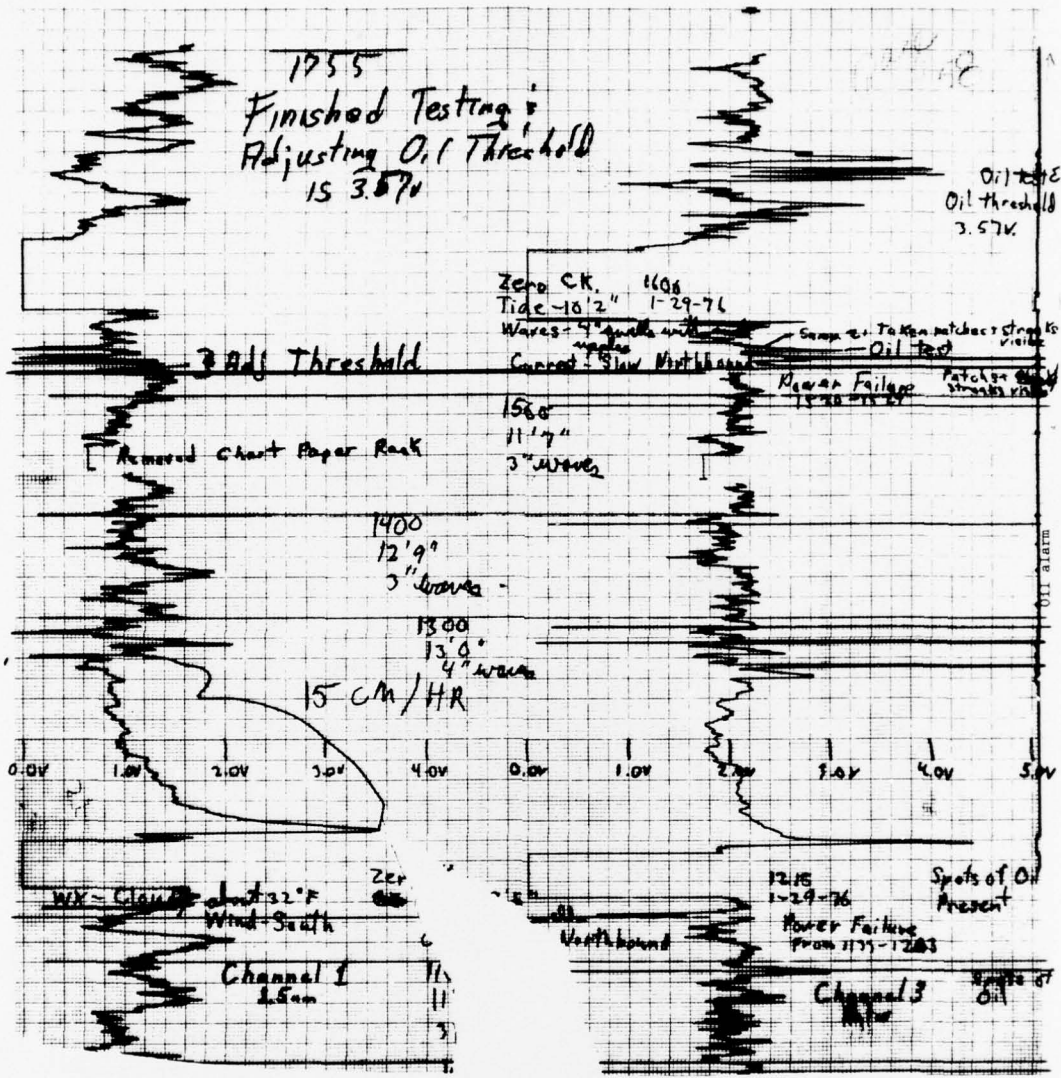

FIGURE 23 - Wright and Wright sensor strip chart recording showing sharp response to visible streaks of oil. Sample #21. 29 January 1976. Speed 24 min. = 1 cm.

verified the presence of oil. In two of the three instances, small streaks of visible oil were observed. Throughout the evaluation period it was usually observed that when visible oil was present the alarm channel would increase markedly to 5 volts or more. Figure 21 shows a sharp response of over 5.0 volts for small visible streaks of oil (Sample 14). Figure 22 shows a sharp response over 5.0 volts for Sample 17. Figure 23 shows strong response over 4.0 volts for visible streaks of oil (Sample 21). It must be remembered that other petroleum products may be thick enough to form visible sheens but they will not increase the ratio level nearly as high as 5 volts

#### 8.6 Reliability for Unattended Operation

The sensor had only two periods of faulty operation. The first happened on 30 October 1976 when the transmitter lamp was broken during installation. A replacement was not available immediately and the lamp was not replaced until 17 November 1976. On 17 December 1975, the sensor was removed from the platform for a check. An IC relay was discovered loose and reinserted. Before the sensor could be remounted, it was accidentally dropped from a work table to the floor. The sensor was subsequently returned to the manufacturer for repair. It was reinstalled in Bayonne on 12 January 1976 and operated flawlessly for the duration of the test period.

Overall, the sensor operated remarkably well. It was simple to align and maintained a steady channel 3 signal level over the tidal ranges encountered. It had no replaceable batteries to be monitored.

#### 9.0 OIL SPILLS DETECTED

The sensors were operating for five months from November through most of March. Throughout this period, numerous patches, streaks and spots of oil were detected and observed. Oil pollution case records from the Coast Guard Captain of the Port office in New York indicated there were 17 spills over 100 gallons in the Kill Van Kull and upper bay region of New York Harbor from 1 November 1975 until 1 March 1976. One of these spills occurred on 4 January 1976 at the Patchogue Oil Terminal in the Gowanus Canal. Approximately 2.5 million gallons of oil went into the canal. Containment booms were put in place but the cleanup was not completed until February. Some oil did make it through the containment booms on various occasions.

On 27 January 1976, there was an easterly wind which probably drove some of the oil from the Gowanus Canal the 2.5 miles across the upper bay to the sensor location. The resident technician observed a thin visual sheen most of the day but because of considerable fog during much of the day he did not realize the sheen's extent. Figures 16 and 17, referred to earlier, are extracts of the strip chart recording for this period. Twenty-seven of the 40 times the Wright and Wright sensor exceeded a threshold of 3.5 volts took place on this day. Also both the Rambi and Wright and Wright sensors recorded their longest continuous detection periods. They were 204 minutes for the Wright and Wright and 54 minutes for the Rambi.

One other spill originated in close proximity to the sensors. A U. S. Navy vessel moored at the Military Ocean Terminal spilled about 50 gallons of oil some 100 yards from the sensors. The resident technician observed the cleanup efforts and oil in the water. However, the oil slick passed just far enough out from the end of the pier to not be detected by either sensor.

#### 10.0 CONCLUSIONS

There were two primary objectives of the sensor field test. One was to obtain information on the utility of fixed-site point sensors to comprise a Coast Guard-operated local area harbor oil surveillance system. The other was to determine the operating characteristics of the specific sensors in an actual harbor environment. It is difficult to separate an analysis of the two subjects because the operation of a sensor monitoring system is greatly dependent upon the properties of the actual sensors employed.

First, consider a local area surveillance system comprised of fixed-point sensors. To be operationally desirable, the sensors comprising such a system must unequivocally initiate an alarm in one circumstance only. That is the case when there is a surface oil film large enough to warrant cleanup, preventative measures, or legal action. The result of the Bayonne evaluation indicate that this criterion would be difficult to meet with the two sensors evaluated. The greatest problem appears to be that the sensors are extremely sensitive and can detect small patches of oil as well as very thin oil films. Often the sensors would respond to thin films that were impossible to detect visually because of surface turbulence and poor viewing angles. Neither sensor produces an alarm signal which has a definable relationship with film thickness. Although the specific visible films encountered often did produce stronger alarm indications than the invisible films, further work must be done in this area before the possibility of dispatching response teams in a futile search for barely visible or invisible oil slicks is eliminated. The threshold ratio of the Wright and Wright sensor cannot be increased to 3.5 or 4.0 volts to stop alarms for invisible films. Many of the visible sheens observed at Bayonne did produce ratio levels of over 5 volts but this would not be true of all oil products. Setting the threshold level higher might eliminate the alarms for invisible films but it also might eliminate alarms from visible films of different oils.

The response of point sensors to small patches and streaks of oil could probably be controlled by appropriate time delays. If the sensors are to be operated at unattended sites, the time delays must be set at a minimum of 15 minutes to filter out the intermittent alarm fluctuations from small quantities of oil. To avoid open spots in a large oil slick from resetting the timing cycle to zero, a time delay employing a percent oil detection would be very effective. A good delay criterion might be that a sensor must detect oil for 80 percent of a 15-minute period before it would initiate an alarm. The alarm would then stay on as long as the oil was present 80 percent of the time thereafter.

The problems of thin film sensitivity, threshold levels, and alarm time delays combine to raise serious questions to the practicability of

employing point sensors in a widespread harbor monitoring system. It appears they would be more effective monitoring specific problem areas such as moored tankers or storm drain outfalls.

Throughout the five-month evaluation period numerous streaks, patches, and spots of oil were detected. Some oil was detected from the 2.5 million gallon Gowanus Canal spill but this was 23 days after the spill while cleanup operations were well underway. The sensors did detect oil but they would not have alerted monitoring stations to an unknown spill. An expensive surveillance system would only be of value if it would detect spills earlier than the spill would have been detected without the sensors.

Another example of the limitation of a point sensor system was the 50-gallon spill from the Navy vessel. It originated only 100 yards or so from the sensors. The technician observed oil in the water and attempts to remove it. However, local currents and the wind carried the spill far enough from the sea wall to miss the sensors. Again, the spill was detected by people at the originating location and not the sensor.

Detailed information was acquired on the operating characteristics of the sensor types installed. Consider the Rambie sensor first.

The Rambie sensor had numerous problems which made maintenance of reliable operation a difficult and frustrating experience. At the original installation height of 15.5 feet above mid tide level, the alarm channel signal level would not remain constant over the nearly 6-foot tidal range. It would vary from +.25 volts at high tide to -.25 volts at low tide. This is an excessive variation when it is realized that the maximum oil signature is a drop from 0.0 at clean water to -.5 volts.

The signal fluctuations were eliminated by increasing the installation height to 19.5 feet above mid tide. Although this action solved one problem, it created a situation of dramatically reduced channel 1 and 2 signal magnitudes. Before increasing the height the levels of channels 1 and 2 seldom dropped below 1 volt. While after the increase, they remained usually at .5 volts or less. From this experience it is doubtful if reliable operation could be maintained at heights above 25 feet with normal surface chop conditions.

The background problem was a serious and time-consuming one as well. For proper operation, the Rambie sensor requires the clean water signature to be adjusted to 0.0 volts. Because the oil alarm should be set around -.35 volts, there is not much room for a poor adjustment on the clean water zero reading. It was discovered that often the chemical analysis showed the presence of oil in what was thought to be clean water. Thus to ensure proper sensor installation, an oil sample must be obtained to verify the clean water zero setting was not erroneously adjusted.

In summary, the Rambie sensor was difficult to align, sensitive to tidal variations, dependent upon clean water for initial alignment, required periodic battery replacements, and produced low signal levels

at heights over 20 feet above the surface water. When all conditions were correct, the sensor would detect oil reliably but it certainly did not demonstrate reliable operation throughout the five-month evaluation period.

The Wright and Wright sensor had some noticeable advantages over the Rambi unit. First of all, the initial alignment process was considerably simpler. This is because it employs such features as a 500-watt transmitter lamp which illuminates a wide surface area and automatic gain control. Also, it does not require initialization of an on-site clean water reference. In short, it was possible to install and achieve proper operation in less than one-half an hour employing only a simple voltmeter. This is compared to the detailed procedure requiring an oscilloscope or voltmeter, calm water, and clean surface water verified by chemical sample analysis, for the Rambi device.

In addition, the Wright and Wright was not affected by tidal height variations even when installed as low as 9.2 feet above mid tide level. It did not require periodic battery replacements. A final advantage was the greater magnitude of signal shift when oil was detected. It was not unusual for the signal to increase from an ambient 2.0 volts to over 5 volts. This large an increase makes the oil signal easily detectable from any noise present in the system.

#### REFERENCES

1. Lissauer, Ivan M., A Technique for Predicting the Movement of Oil Spills in New York Harbor, U. S. Department of Transportation Report CG-D-6-75, U. S. Coast Guard, February 1974.
2. McCormack, Kent, Fournier, Gerald, and Knight, William, Oil-on-Water Sensor, U. S. Department of Transportation Report CG-D-87-74, U. S. Coast Guard, February 1974.
3. Wright, David E., and Wright, Judith A., Evaluation of an Infrared Oil Film Monitor, U. S. Department of Transportation Report CG-D-51-75, September 1974.

