

AD-A040 665

NATIONAL AVIATION FACILITIES EXPERIMENTAL CENTER ATL--ETC F/G 17/2
TEST AND EVALUATION OF THE DALLAS/FORT WORTH TERMINAL COMMUNICA--ETC(U)
NOV 76 R W CLEARY, A SPINGOLA, S A KAROVIC

UNCLASSIFIED

FAA-NA-75-61

FAA-RD-76-111

NL

1 OF 1
AD
A040665



END

DATE
FILMED
7-77

Report No. FAA-RD-76-111

ADA040665

12
NW

TEST AND EVALUATION OF THE DALLAS/FORT WORTH TERMINAL COMMUNICATIONS SWITCHING SYSTEM

Richard W. Cleary
Anthony Spingola
Stephen A. Karovic
P.E. Hinely, Jr.



NOVEMBER 1976

FINAL REPORT

DDC
RECEIVED
DEC 8 1976
A

Document is available to the public through the
National Technical Information Service
Springfield, Virginia 22151

AD No. —
DDC FILE COPY

Prepared for

U. S. DEPARTMENT OF TRANSPORTATION
FEDERAL AVIATION ADMINISTRATION
Systems Research & Development Service
Washington, D.C. 20590

NOTICE

This document is disseminated under the sponsorship of the Department of Transportation in the interest of information exchange. The United States Government assumes no liability for its contents or use thereof.

Technical Report Documentation Page

<p>1. Report Number 18) <u>19</u> FAA-RD-76-111 ✓</p>	<p>2. Government Accession No.</p>	<p>3. Recipient's Catalog No.</p>	
<p>4. Title and Subtitle 6) TEST AND EVALUATION OF THE DALLAS/FORT WORTH TERMINAL COMMUNICATIONS SWITCHING SYSTEM,</p>		<p>5. Report Date 11) November 1976</p>	<p>6. Performing Organization Code</p>
<p>7. Author(s) 10) Richard W./Cleary, Anthony/Spingola, Stephen/Karovic, and P. E./Hinely, Jr.</p>	<p>8. Performing Organization Report No. 14) FAA-NA-75-61 ✓</p>		<p>10. Work Unit No. (TRAIS)</p>
<p>9. Performing Organization Name and Address Federal Aviation Administration National Aviation Facilities Experimental Center Atlantic City, New Jersey 08405</p>		<p>11. Contract or Grant No. 063-221-000</p>	<p>13. Type of Report and Period Covered 9) Final rept. May 1975 - June 1975,</p>
<p>12. Sponsoring Agency Name and Address U.S. Department of Transportation Federal Aviation Administration Systems Research and Development Service Washington, D.C. 20590</p>		<p>14. Sponsoring Agency Code</p>	
<p>15. Supplementary Notes 12) 78p.</p>			
<p>16. Abstract This report details the operational and technical evaluation of the air traffic control (ATC) terminal communications switching system (TCSS) at the Dallas/Fort Worth Tower/TRACON (Terminal Radar Approach Control) facility by personnel from the National Aviation Facilities Experimental Center. The system was designed and built for the Federal Aviation Administration and is innovative in that it uses frequency division multiplexing techniques for ATC instead of conventional communication-channel separation methods. The following are other TRACON communication innovations: communications are carried over a single coaxial cable in the 10-MHz to 15-MHz band; solid state logic circuitry is used for electronic switching of voice and radio-remoting interconnections; positional communications reconfiguration is under processor control; and all direct access keys and radio-select keys use light-emitting diodes for designators. In addition to a technical evaluation of equipment performance, an evaluation of the ATC operational performance of the TCSS was conducted using facility personnel as test subjects. Responses on questionnaires completed by the test subjects indicated that, with minor exceptions, the system satisfies requirements. Learning to operate a system position requires a minimal amount of training, and the system has the capabilities of growth and flexibility.</p>			
<p>17. Key Words Terminal Radar Approach Control Terminal Communications Switching System Frequency Division Multiplexing Air Traffic Control</p>		<p>18. Distribution Statement Document is available to the public through the National Technical Information Service, Springfield, Virginia 22151</p>	
<p>19. Security Classif. (of this report) Unclassified</p>	<p>20. Security Classif. (of this page) Unclassified</p>	<p>21. No. of Pages 80</p>	<p>22. Price</p>

PREFACE

Grateful recognition is acknowledged to the following contributors to this report:

James R. Monnie, ARD-223, the MITRE Corporation, Air Traffic and Airways Facility, and personnel from the Southwest Region.

ACCESSION for	
HTIS	White Section <input checked="" type="checkbox"/>
DOC	Buff Section <input type="checkbox"/>
UNANNOUNCED	<input type="checkbox"/>
JUSTIFICATION.....	
BY.....	
DISTRIBUTION/AVAILABILITY CODES	
Dist.	AVAIL. and/or SPECIAL
A	

TABLE OF CONTENTS

	Page
INTRODUCTION	1
Purpose	1
Background	1
Description of Equipment	1
System Requirements	3
Test Team Development	3
OPERATIONAL EVALUATION	4
Test Environment	4
Test Design	10
Outline of Tests	10
Questionnaire Results	11
TECHNICAL EVALUATION TESTS	13
Test Categories	13
Reliability	14
Maintainability	16
Technical Manageability	18
Expansion Potential	20
Determination of Functional Operating Characteristics	25
Interfaces	26
Safety	33
Technical Summary of Results	34
CONCLUSIONS	36
RECOMMENDATIONS	38
APPENDIXES	
A - TCSS Functions and Features	
B - TCSS Operational Evaluation Test Director Script	
C - Collated Air Traffic Controller Questionnaire for the Evaluation of the TCSS at the Dallas/Fort Worth Tower/ TRACON	
D - Microprocessor Structure and Programmer Skills	
GLOSSARY	

LIST OF ILLUSTRATIONS

Figure		Page
1	TCSS Subsystem Distribution	2
2	View of Dallas/Fort Worth Airport with Tower/TRACON Structure in Right Center	5
3	DFW Control Tower Positions	6
4	DFW TRACON Positions	7
5	TCSS Installation on Vertical Displays in TRACON	8
6	TCSS Installation on Horizontal Displays in TRACON	9
7	Combined Filter Response for High- and Low-Band Separation	21
8	TCSS Radio Selector Panels	27
9	UPS Lead-Calcium Battery Cells	28
10	Phase 1 to Neutral Comparison	29
11	UPS Harmonic Distortion	30
12	Line Voltage Regulator (LVR) Harmonic Distortion	31
13	Commercial Power Harmonic Distortion	32

INTRODUCTION

PURPOSE.

The National Aviation Facilities Experimental Center (NAFEC) conducted an operational and technical evaluation of the terminal communications switching system (TCSS) at the Dallas/Fort Worth (DFW) Regional Airport. The purpose of this evaluation was threefold: first, to insure that the TCSS satisfies all air traffic control (ATC) communication requirements for the DFW Tower/Terminal Radar Approach Control (TRACON); next, to determine the potential of TCSS as a candidate system for future procurement; and finally, to identify any communication equipment design changes which may be necessary to accommodate terminal ATC environments projected for the 1980's.

BACKGROUND.

The Federal Aviation Administration (FAA) issued a contract to the AMECOM Division of Litton Industries, Inc., for a communications switching system to serve the new DFW terminal area and to provide a flexible framework (for reconfiguring communications, distributing load equally throughout the TRACON in a matter of seconds) and to match the growth in traffic load of the FAA ATC system. As a result, the TCSS was developed (figure 1), designed specifically for terminal ATC communications.

The TCSS provides the capability for voice communications among air traffic controller positions, support equipment, and facilities external to TCSS, including remote radio equipment for aircraft communications. This is the first FAA-owned TRACON communications switching system. The innovative equipments and operational techniques utilized presented a compelling reason to conduct an evaluation of the TCSS prior to commissioning. A NAFEC team was assigned the responsibility for developing a test plan and conducting the evaluation of the TCSS. The evaluation was conducted after system acceptance and prior to final commissioning.

This report documents the results of the evaluation and is presented in two parts, the operational evaluation and the technical evaluation. The former consists of subject controller questionnaires and comments, and the latter consists of equipment tests.

DESCRIPTION OF EQUIPMENT.

The TCSS is a unique Tower/TRACON communications switching system in that it provides intercom, interphone, and radio communications via coaxial cable without a central switching complex. Its reconfiguration capabilities to reapportion communication loads provide for rapid response to changing traffic load conditions through rapid selection of one of several preprogrammed configurations to distribute communications automatically or through the manual insertion of changes. It is the first and only frequency division multiplexed (FDM) system owned by the FAA and has been designed to replace space division systems such as those that are leased for similar TRACON facilities. A detailed description and definition of TCSS functions and features is given in appendix A.

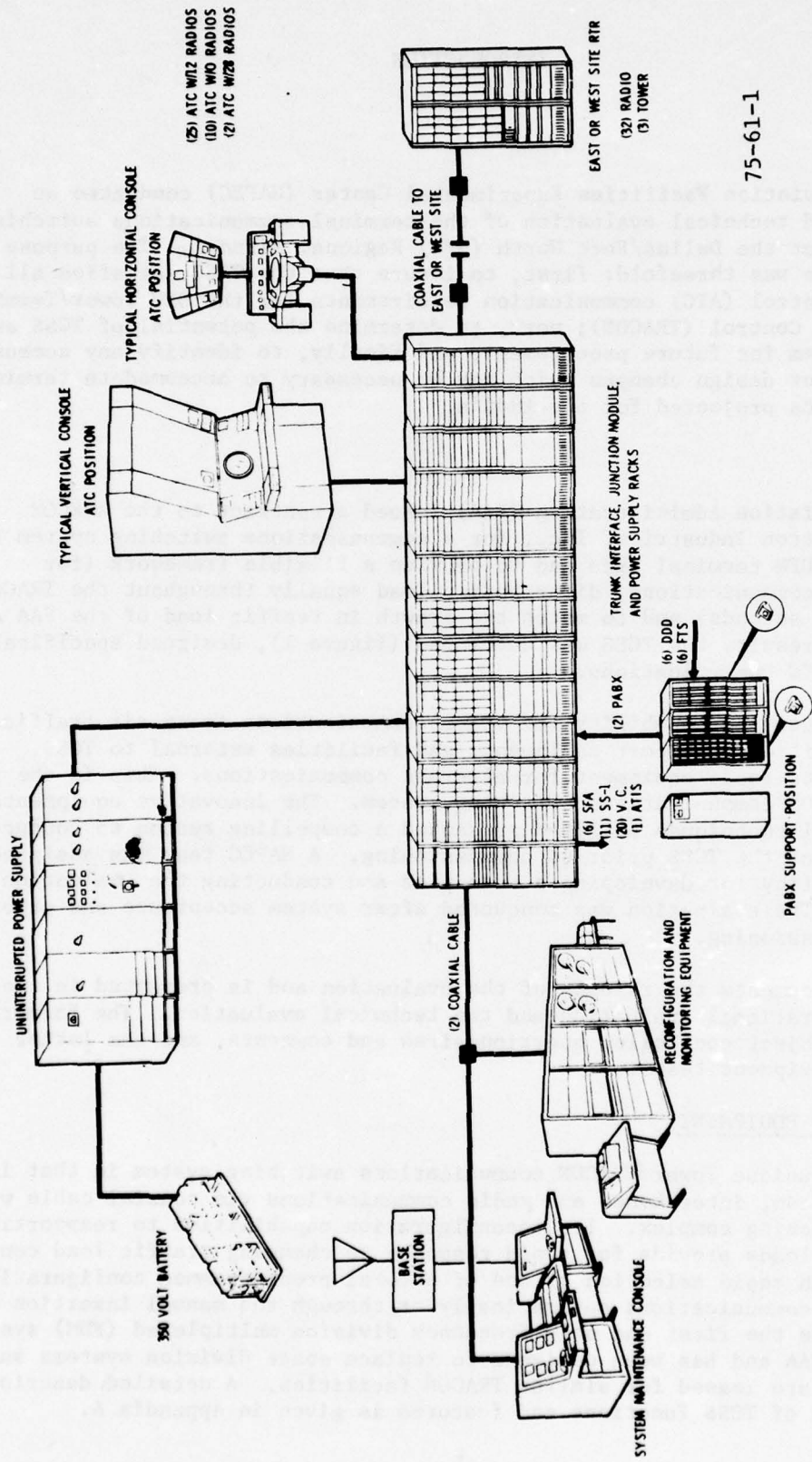

75-61-1

FIGURE 1. TCSS SUBSYSTEM DISTRIBUTION

SYSTEM REQUIREMENTS.

The diversified types of ATC communications employed in a terminal control operation and the high degree of reliability in communications that is required for control of aircraft have fostered evolution of the complex space division switching systems that are presently employed. Greater flexibility and speed of communications than have been available are needed to enhance the ATC capabilities that the most advanced weather displays and developing automation can provide.

A terminal system must now include the following functions: direct access intercom, with and without override; voice call; remote radio control; selective signaling; Automatic Terminal Information Service (ATIS); tape recording of all ATC voice communications; and access to and from long-line trunks. Additional requirements were imposed on TCSS to allow for greater flexibility and growth capability for application in the upgraded third generation (UG3RD) ATC communication system.

Computer-controlled reconfiguration provides the major element of flexibility. The TCSS can be entirely reconfigured in less than 8 seconds under central processor control. The processor is also used for traffic data collection and to support a configuration editing program through which the 10 available configurations can be changed to accommodate additional controller positions, new sectorization, and additional special ATC functions. The processor is not required for any of the communication switching or control functions. Once the system is reconfigured, both of the dual processors can be turned OFF, and the system is under control of 38 microprocessors, one in each active position.

The system interconnection is redundant between positions, since two coaxial cables are used instead of one. Two more coaxial cables carry radio control and communications to remote transmitter receiver sites (RTR) on opposite sides of the airport. Main and standby receive/transmit pairs are split between the sites and do not share common cables nor repeater amplifiers. The potential for growth to accommodate approximately 50 active controller positions is incorporated in the design through modularity, unused bandwidth, spare memory in the position processors, unused addresses in the numbering plan, and expansion room in the reconfiguration programs. The expanded system would remain in the 10-to-15-megahertz (MHz) frequency band, with a single unmodulated reference frequency at 5 MHz. Low-pass filters with a cutoff frequency of 17 MHz are used throughout the system to protect it from other carrier systems which may be added in the future to transmit video or digital data over the coaxial cable system.

TEST TEAM DEVELOPMENT.

Upon issuance of a program area agreement by System Research and Development Service, a NAFEC test team was formed to prepare an evaluation test plan for TCSS at the DFW TRACON. This test team was composed of one electronic engineer, two air traffic control specialists, and one communications specialist.

A test plan was developed in conjunction with ARD-223 and MITRE. It was coordinated with ASW region and DFW personnel during the week of March 10, 1975 for review and concurrence. The final test plan was agreed upon prior to actual testing.

Evaluation testing was performed by the NAFEC test team in conjunction with ARD-223 and DFW operations and technical personnel.

OPERATIONAL EVALUATION

TEST ENVIRONMENT.

The TCSS is installed in the Tower/TRACON structure at the Dallas/Fort Worth (DFW) Airport (figure 2). Thirteen communications positions are installed in the control tower cab (figure 3), and 24 positions are installed in the new TRACON located on the first floor of the tower structure (figure 4). One position is assigned to the system maintenance console located in the equipment room. The control tower at the time of the evaluation was a commissioned facility. The TRACON was commissioned in July 1975, after the evaluation. The TRACON had a completely installed automated radar terminal system (ARTS III) display system, having both vertical (figure 5) and horizontal (figure 6) radar displays. The TCSS is integrated with all operating positions in the Tower/TRACON environment, and system interconnection was made to remote air/ground RTR sites peripheral to the airport.

The DFW TRACON ARTS III system, installed in a room at the base of the tower structure, was not as yet commissioned for operations at the time of the evaluation. Approach control services were being rendered from the TRACON located at the Greater Southwest Airport and only passively monitored by the test subjects at DFW.

During test activities prior to commissioning, observers and controller test subjects did not actually control radar data on the ARTS III displays. These displays provided the basic stimuli for the controller subjects under actual operational conditions.

The DFW TRACON radio receivers were operational; however, there was no capability for transmitting, thus the controllers were instructed to simulate a radio response to an aircraft. The intercom was exercised fully; however, the interphone function was somewhat restricted so as not to interfere with actual operations.

During the tests, technical modifications were being performed by contractor personnel and at times caused certain functions or features to be voided or to malfunction.

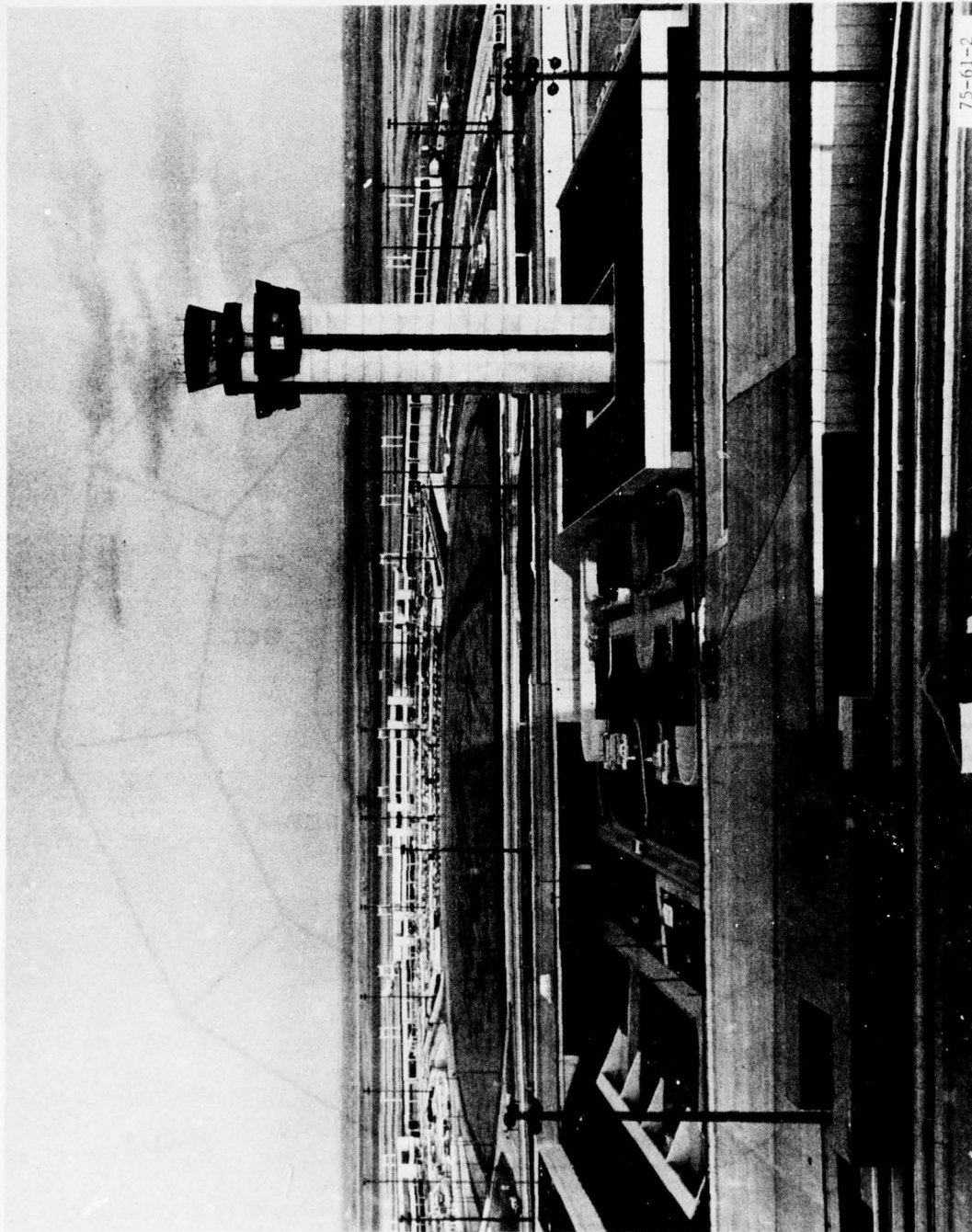

FIGURE 2. VIEW OF DALLAS/FORT WORTH AIRPORT WITH TOWER/TRACON STRUCTURE IN RIGHT CENTER

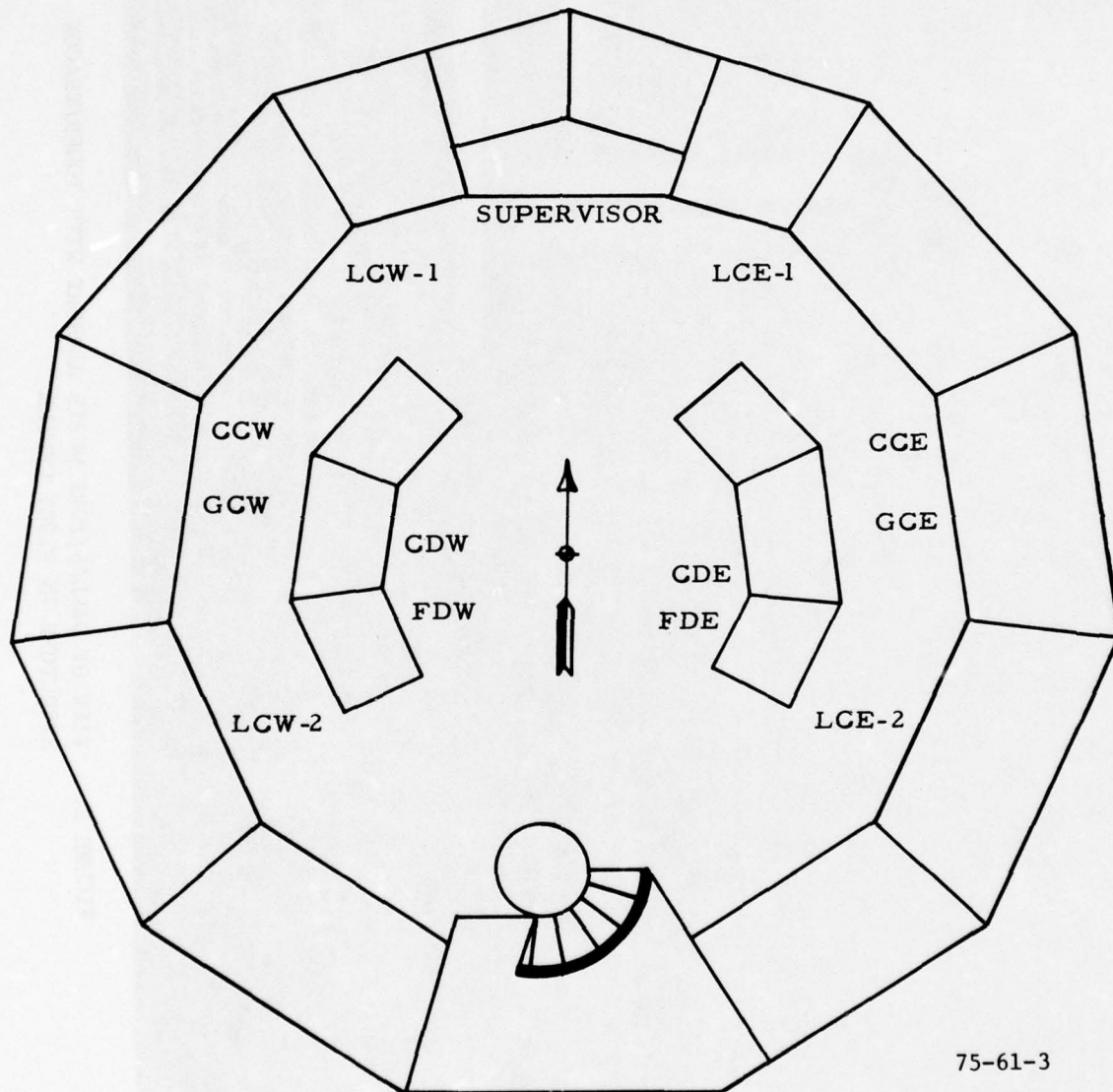
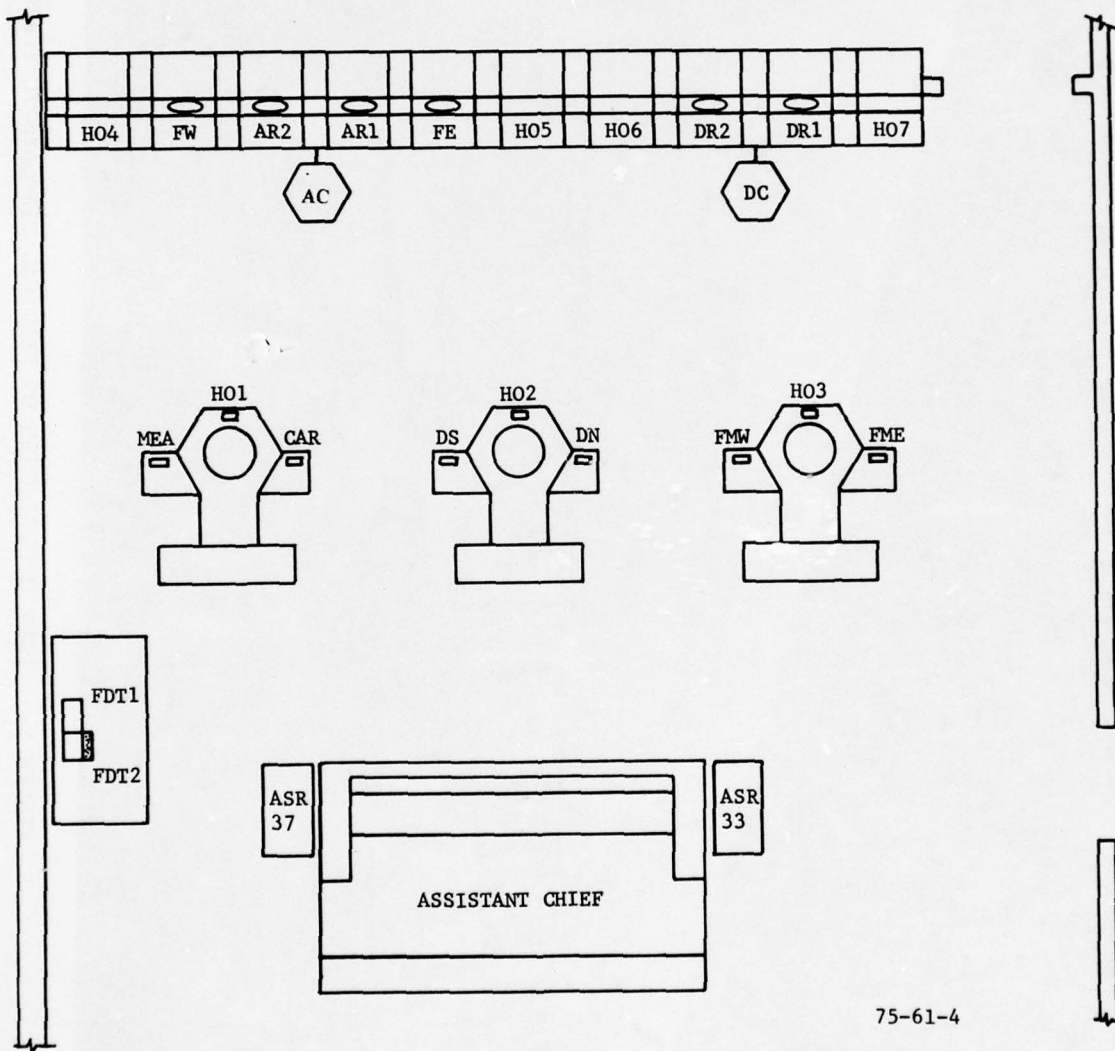
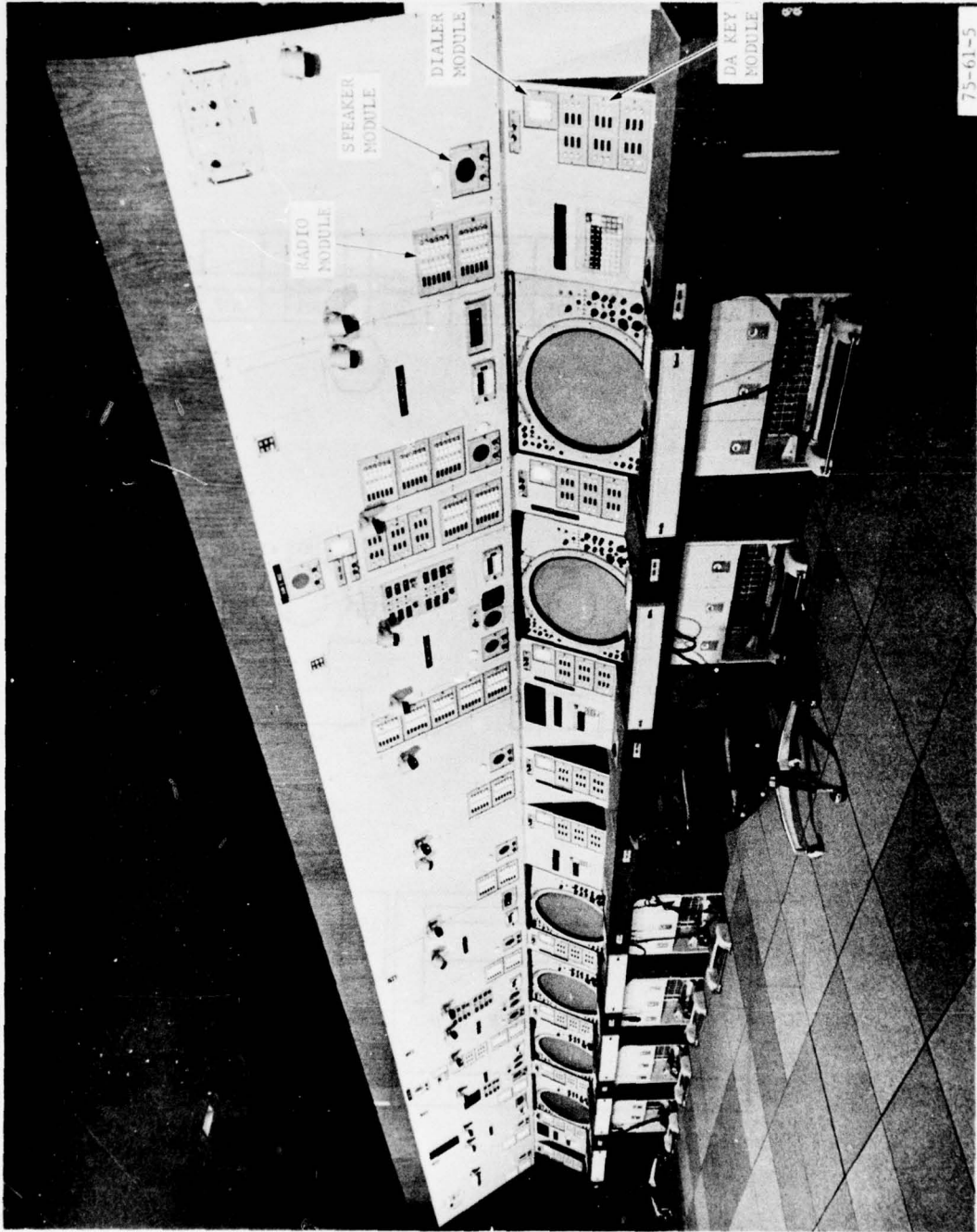

FIGURE 3. DFW CONTROL TOWER POSITIONS (SEE GLOSSARY FOR POSITION DESCRIPTIONS)



75-61-4

FIGURE 4. DFW TRACON POSITIONS (SEE GLOSSARY FOR POSITION DESCRIPTIONS)



75-61-5

FIGURE 5. TCSS INSTALLATION ON VERTICAL DISPLAYS IN TRACON

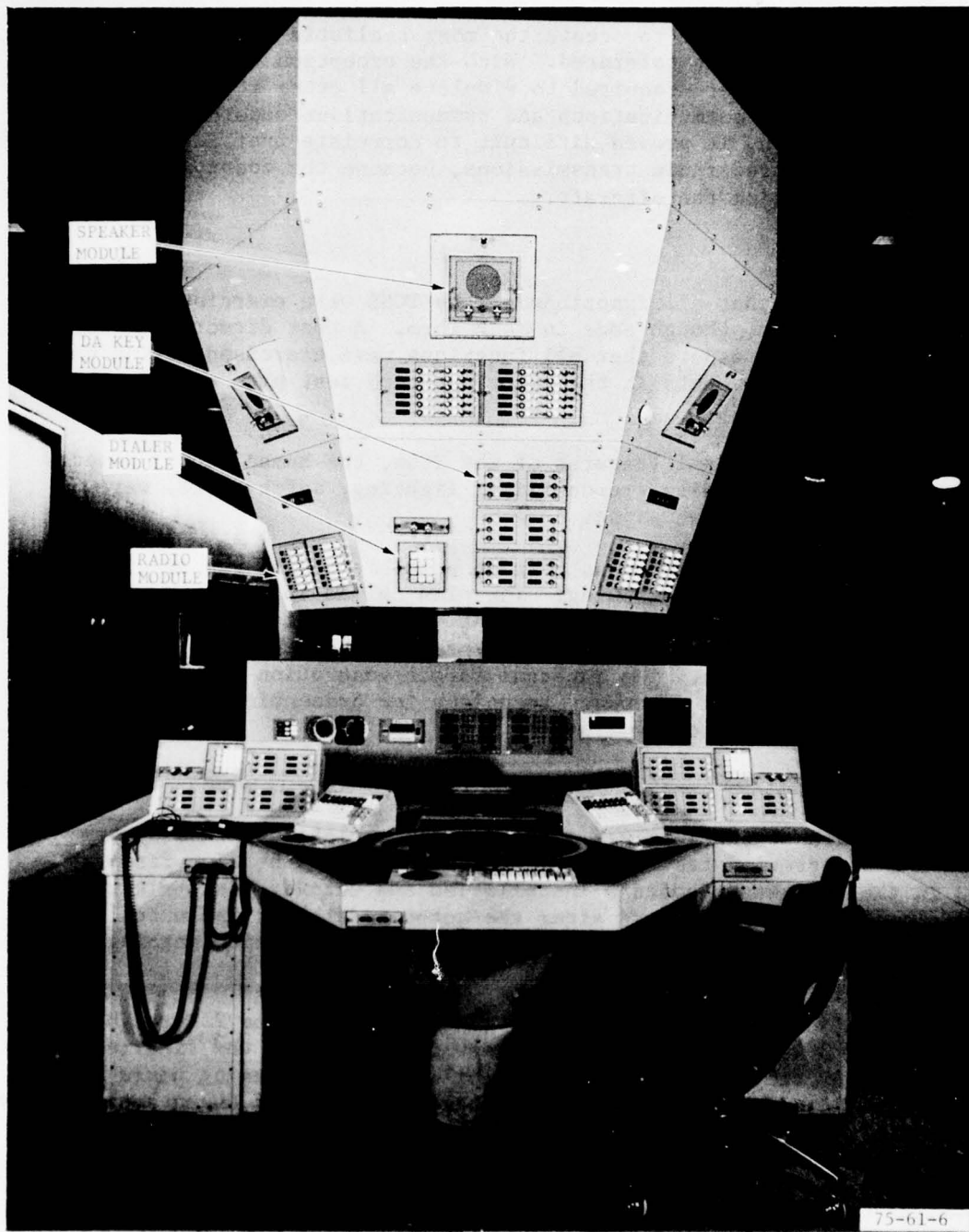

FIGURE 6. TCSS INSTALLATION ON HORIZONTAL DISPLAYS IN TRACON

Although every effort was made to create the most realistic operating conditions, certain compromises had to be tolerated. With the exception of intercom messages, the test subjects were required to simulate all other related communications including aircraft communications and communications outside the tower and TRACON. In addition, it proved difficult to correlate traffic on the display with the monitored radio transmissions, because the controller subjects were not actually handling the aircraft.

TEST DESIGN.

Tests were designed so that all functions of the TCSS were exercised by the controller test subjects, though some in mock form. A test director's script (appendix B) was used to assure that all functions were exercised during each test period. All test elements in the prior approved test plan were employed in the TCSS testing.

In addition to the operational features of the TCSS, the human factor aspects of viewing angle, module design, readability, lighting, safety, etc. were considered a part of this evaluation.

The TCSS was exercised in a manner as near as possible to the way it will be used in operations after commissioning. The plan called for the use of the ARTS III system to its fullest possible extent to add realism and validity to the evaluation task. Traffic information presented on the displays was derived from live radar data. The internal target-generation function of the ARTS III was to be used as a secondary technique for presenting radar data; however, need for this did not develop.

OUTLINE OF TESTS.

1. The evaluation of the TCSS was started upon completion of the system acceptance and integration tests and was conducted within the time frame as specified in the Southwest Region's installation and cutover plan. In the event additional data were desired after the cutover date, it was mutually agreed that this could be accomplished without interfering with ongoing activities.
2. The evaluation was conducted during the period from June 2 through June 11, 1975. A 3-week test period was planned, but due to the fine response of the personnel of the Dallas/Fort Worth facility during evening hours and weekends, the required number of questionnaires was completed on an availability basis in less time than anticipated.
3. The evaluation plan called for the completion of 75 questionnaires. (Seventy-eight were actually completed.)
4. Each evaluation run was 2 hours in duration.

5. The number of control positions manned during an evaluation run was dependent on the availability of test subjects and could not be a fixed number. The requested number by NAFEC was two to five subjects per run. Records indicate the majority of runs had four controllers. A record was made of the positions worked on each run and the subjects' names.

6. Due to the diversification of operating sectors, some subjects repeated test runs, but at different positions. This accounts for 55 controllers completing 78 questionnaires.

7. The majority of test runs were conducted in the TRACON, which was fully functional, but not yet as a commissioned facility. The control tower was a commissioned facility, but due to space restrictions and possible interference to operations, only one test subject per run could be accommodated there.

8. The first 1/2 hour of each test period was allocated to rehearsing the items of the test director's script. This was to assure that all functions of the TCSS were familiar to the controllers and could be utilized during testing.

SPECIFIC DATA COLLECTED. The questionnaires completed by the test subjects constitute the primary data collected in this operational evaluation. The questions covered the following categories:

<u>Category</u>	<u>Applicable Question Items</u>
Operations	1 through 16
Human Factors	17 through 32
Expansion Features	33 through 36
Flexibility	37 through 39
Reliability	40 through 43

The collated questionnaire is in appendix C.

SUBJECT SAMPLE. A total of 55 test subjects participated in this evaluation. Thirty-three participated one time; 21, two times; and 1, three times. Thus, a total of 78 questionnaires were obtained. All who participated in this evaluation were performance-rated controllers from the Dallas/Fort Worth Tower/TRACON.

QUESTIONNAIRE RESULTS.

ANALYSIS OF SYSTEM OPERATIONS.

1. The responses to questions 1 through 6 relating to the quality and performance of the radio and intercom circuits were very favorable. All but one response rated the overall quality of the radio and interphone circuits good to excellent. On question 5, 26 of the 78 controller responses indicated awareness of background noise, of which 15 responses stated the noise was a

deterrent to good working conditions, while 20 responses said the noise did not affect work. Throughout the tests, it was noted that the reported noise source was principally from one position. Later it was found to be caused by defective equipment.

2. Questions 7 through 15 addressed the operation of the system. The overall response was favorable. Twelve negative responses to question 11 indicated that the controller had difficulty operating the TCSS (65 responses indicated no difficulty). The negative comments related to difficulty in reading the light-emitting diodes (LED's), time delay on status indicators, and in using sticking pushbuttons.

Question 13 brought out the same negative comments noted above on question 11. Fifteen responses indicated that not being able to hear aircraft transmissions at a radio position being overridden was an undesirable feature. This feature received more negative responses than any other single system feature.

3. All controllers stated that learning to operate the system was easy, and transitioning from the present system would present no problems.

4. In responding to question 16, 68 responses indicated the TCSS would meet the needs of the controller, while 4 responses indicated it would not. There were no comments associated with the four negative replies.

5. A breakdown of controller responses and comments is given in appendix C.

ANALYSIS OF HUMAN FACTORS CONSIDERATIONS.

1. Responses to the positioning of TCSS panels in the tower cab and at the horizontal and vertical display positions in the TRACON (questions 17 through 19) were very favorable. The only significant unsatisfactory notations (11) were regarding the location of the speaker unit at the horizontal display positions. A tall person upon standing up could bump his head with the hinged panel in the down position.

2. The responses to question 20 definitely indicated that the readability of the LED in the tower cab was unacceptable due to the high ambient daytime light level. A "very good" response was recorded seven times by test subjects; however, it was later determined that they were considering nighttime periods.

3. When asked about the readability of the LED's in the TRACON, the majority of the responses (excellent 15, very good 41) were favorable; however, 22 responses reported readability as poor to unreadable. The reason given for poor readability were color and poor character formation. The letter "S" and number "5" were not easily discriminable.

4. The majority stated that there were no unsafe physical features of the TCSS. The location of the speaker unit on the horizontal display was again mentioned (15 responses) as a hazard.

5. Comments indicated that the test subjects had no major problems with such items as pushbutton design and spacing, headset, speaker and chime controls, and the overall ease of operating the system. Several comments were made relative to the excessive length of the status pushbuttons on the direct access and radio panels, and indicated shorter buttons would be less easily broken.

6. Judging from the answers to question 31, the most effective function of the TCSS was the direct access (DA) capability.

The most liked feature of the TCSS was the voice quality on the interphone and radio circuits. (A detailed list of other function and feature preferences are contained in appendix C.)

ANALYSIS OF TCSS EXPANSION; FLEXIBILITY AND RELIABILITY FEATURES.

1. A negligible number of the controller test subjects had experience with the TCSS, and therefore response to expansion questions could be misleading. However, in answering question 34, a large majority (64 of responses) indicated the system would be able to accommodate the increase in future traffic, while only 11 responses were in the negative.

2. Flexibility characteristics of the TCSS were thought to be sufficient for conducting controller communications duties. The test responses were unanimous (66-0) in agreeing that the reconfiguration feature of the TCSS provided maximum flexibility for combining control sectors. The "call forward" function, they indicated, provided an efficient way to transfer calls. They also indicated the TCSS provides more flexibility than the system they are presently using.

3. Reliability of the system could only be determined for the period during the testing. Comprehensive reliability data will have to be collected as the system is used over longer periods of time.

The overall operations of the TCSS during the tests were good. Malfunctions reported by the test subjects pertained to sticking pushbuttons and button-light failures.

On question 42, 31 test subjects stated that they had to depress pushbuttons more than one time for activation. Part of this was attributed to the lag in the status lamps when activating or deactivating a pushbutton. If a pushbutton was depressed and the light did not change immediately, the subject felt no connection had been made and would continue to depress the pushbutton.

TECHNICAL EVALUATION TESTS

TEST CATEGORIES.

The evaluation was conducted after factory acceptance tests, site acceptance tests, and a partial joint acceptance inspection by ARD and ASW, but prior to

cutover of the TCSS to a commissioned status. These reported test results supplement the site acceptance test results and provide a basis for the specification of future terminal-area ATC communication system.

The tests were categorized into the following six broad areas:

1. Reliability,
2. Maintainability,
3. Expansion Potential,
4. Function Operating Characteristics,
5. Interface Requirements, and
6. Safety.

Subject observations which reflect on the utility or potential of TCSS and similar FDM systems, were recorded and are included along with specific test results to support the conclusions and recommendations of this report.

RELIABILITY.

Reliability of performance was monitored during the course of TCSS evaluation, and all maintenance records were checked to determine failure rates of individual components and to determine if failures could be repaired locally or had to be returned to the factory.

NONREDUNDANCY TESTS. Several redundant elements of the system were disabled to determine the effect of single failures on system performance in a nonredundant mode. Coaxial cables were removed from between distribution assemblies and main and standby cable couplers. Main and standby frequency references were turned OFF and disconnected. Main and standby power supplies for position electronics were turned OFF or failed. RTR amplifiers were disconnected or turned OFF. Main and standby central processors were turned OFF. Coaxial cables to RTR sites were opened, and the power source was transferred from the uninterruptable power supply (UPS) to the line voltage regulator (LVR).

None of the single failures that were induced resulted in system failure or interrupted even a fraction of the system functions for more than the few seconds required for an automatic local reconfiguration. There was no operationally noticeable degradation of system performance. All of the failures but one were detected by the real time quality control (RTQC) monitor and could have been isolated through an interpretation of the failure indications. However, disconnecting junction modules (JM) 5 and 6 from the coaxial cable coupler did not alarm the RTQC. The RTQC interrogates each position electronics (PE) through the PE home transmit/receive synthesizer (TRS). The PE replies with its calling TRS. Junction modules 5 and 6 are used only for radio communications for those PE's having 28 radios. The coaxial connections to all of 28 radio PE's (DR-1, DR-2, SMC) and HO-6 is through JM-4 and HO-6. Therefore, the RTQC signals do not go through JM-5 or JM-6. Redistributing the PE's so that DR-1 and HO-6 go through JM-4, DR-2 goes through JM-5, and system maintenance console (SMC) goes through JM-6 would rectify this condition of undetected faults. Some additional hardware is required in the junction modules to accomplish this redistribution.

Power supplies for the positions are redundant, while the positions themselves are not. Any failure at a position disables some or all of the position functions. Replacing a failed module at the position can be accomplished without shutting the position down, but in most cases the position utility is impaired until after the replacement and a local reconfiguration has been accomplished. With the exception of the position electronics, replacements can routinely be made in less than 10 minutes.

The dual central processors are operated in a main online and standby offline configuration with automatic transfer in the event of a failure in the online computer. This transfer can not be accomplished if the offline computer is being used for other work.

The voice-call matrix is not redundant. This matrix distributes incoming voice calls through the reconfiguration and monitor control (RME) modems and PE monitor receivers to the position speakers that are associated with the voice-call trunks by the last reconfiguration. A failure of the matrix can disable all incoming voice calls until the matrix is replaced. Partial functional failures of the voice-call system occurred many times during the test period. Attempts to disconnect from a voice-call connection failed, effectively preventing the voice-call trunk from accessing the speakers at the ATC positions for a period of 80 seconds, after which an automatic dropout disconnected the call. The dropout period was changed to 5 seconds to reduce the delay in reestablishing voice-call communications on the trunk. Failure to speak over the circuit for more than 5 seconds, thereby failing to activate the voice-operated switch (VOX) and reset the dropout timer, resulted in too many disconnects of active calls. The dropout timer was set at 15 seconds as a compromise. The problem was not corrected. Failure to disconnect can still disable the incoming voice calls for extended periods. Every time another facility attempts to establish communications over the trunk, the voice signal resets the dropout timer and extends the dropout period by another 15 seconds.

The multiplexer and RME modems are also nonredundant. Failure of the multiplexer prevents reconfiguration and traffic data collection (TDC). The system remains operable, but highly susceptible to those transient induced failures that are normally self-healing through local automatic reconfiguration by the RME. Failure of a single RME modem affects only the position associated with the modem. Again, the position will remain operable with the current direct access (DA) pushbutton configuration.

Modems for individual trunks, TRS's for radio communications, and the audio switching for radio in the junction modules are single thread. Failure of modems or TRS's result in the loss of one trunk or one radiofrequency. Failure of the switching logic disables 12 frequencies at each of 4 positions. The 5-MHz frequency standard consists of two oscillators in one equipment drawer. The oscillators are phase-locked together. Failure of one oscillator does not interrupt communications. It will be difficult to service the oscillators because they are located in the lowest drawer under the maintenance console, the drawer does not rotate to provide access to the components on the bottom.

The oscillators share a common input power connector. This dual reference is the most likely cause of total system failure. Should both oscillators fail or should the primary oscillator become noisy, the entire FDM system will be inoperative.

FAILURE RATE. The recorded failure rate between March 31, 1975, and June 3, 1975, was 2.4 per day. Only those failures which resulted in the replacement of components or modules were recorded. Malfunctions which were cleared by local reconfiguration, tightening of connectors, loosening of radio module pushbuttons, etc., were not recorded. The unrecorded failures were, in a large part, caused by operating the system under test conditions, such as injected noise, attenuation inserted in signal paths, removing and replacing connectors, and cycling radio control pushbuttons, rather than normal conditions.

Radio pushbuttons were broken in various ways, such as by thrown flight plan data strip holders, accidental bumping, and excessive pressure by operating personnel. Shorter pushbuttons are available that will operate properly and have a longer service life. Temporary malfunctions which are cleared by local reconfiguration include walking LED's and microprocessor timing shifts. Occasionally, alphanumeric characters that are displayed on LED's shift position or become completely garbled. These walking LED's do not affect the operation of the associated pushbutton, and the trouble disappears upon reconfiguration. Microprocessor timing shifts are more serious, because they cause the radios associated with the PE to shift between main, standby, or to nonselected at a rapid rate, and all four positions connected to the same junction module are denied access to all radio control. Reconfiguration clears the problem, but not before the traffic data collection program has recorded several thousand useless words of information which obscure any information of value to traffic studies.

MAINTAINABILITY.

Since the TCSS is a one-of-a-kind system which was custom-made for the DFW Tower/TRACON, maintenance is being performed by the manufacturer, AMECOM field engineering group, with support from the manufacturing plant. FAA personnel are receiving formal and on-the-job training in maintenance in preparation for assumption of maintenance responsibility. Maintainability of the system was evaluated in the areas listed below to determine future system requirements.

MODULE REPLACEMENT. DA modules, radio modules, speaker modules, indirect address (IA) modules, and jack modules were replaced at several positions in the TRACON. The average time for replacement was 4 minutes for speakers, IA, and jack modules, and 6 minutes for modules which require local reconfiguration after replacement. Elapsed time was measured from the time a module was selected for replacement until reconfiguration was complete, and the position was then fully operable. Times were slightly longer for modules in the overhead tubs above the horizontal displays. Replacement times for tower positions include the time it took to bring spares from the spare parts room. The remote radio sites are located approximately 20 minutes from the TRACON by service vehicle. Once at the site, replacement of modems can be accomplished in a few minutes.

Transmitter-receiver-synthesizer (TRS) units were changed, as were the position electronics modules, in less than 10 minutes. The frequency of the home and monitor TRS must be set prior to replacement, but it was demonstrated that changing frequency does not add appreciably to the replacement time. In one instance, the spare TRS would not work in position HO-4 with a frequency of 14.770 MHz. The same spare did work in another position with a lower frequency.

SPARE PARTS QUALITY ASSURANCE. Some of the more complex spares, such as the voice-call matrix and the RTQC distribution box, had not been checked prior to the evaluation tests. Several wiring changes and repairs to the spares were required to make them operable, so the replacement of some of these complex equipments took several hours. The physical act of replacing them took less than 1/2 hour in all cases during the evaluation. Future replacement should not require additional changes and repair because the spares are now 100-percent checked in operation.

Spares as delivered from factory repair were also found to be defective during the replacement tests. The defects which caused their return for factory repair were not detected on the maintenance test console, and the units were returned to DFW as operable. The onsite repair of the units with an onsite test bench and minisystem testing device should correct this condition, because the same personnel who remove the unit will be able to localize the defect and repair it.

REAL TIME QUALITY CONTROL. Tests showed that detection of a fault by the RTQC results in a light being activated on the monitor panel which is associated with the faulty position or modem, a printout of the time and number of the light, and an aural alarm. Faults which only show up on either the main or the standby cable result in repeated alarms every time the RTQC cycles through the affected cable. A fault that shows up on both cables, prints out one time and keeps the light ON.

Most faults can be isolated to a modem, module, power supply, etc., by interpreting the combinations of fault lights, power supply lights, and position self-checks. Junction module failures normally cause failure indications for all of the PE's connected through the junction module.

The teletype printouts were not utilized during the evaluation period, because tests of spare parts usually resulted in many erroneous indications of failures. The aural alarm was disconnected for the same reason. The RTQC does not record failure indications on magnetic tape or disc for computer analysis.

TEST EQUIPMENT. The maintenance contractor utilizes FAA and contractor-owned test equipment to maintain and repair the system. The AMECOM-owned equipment is not deliverable under the contract. It includes a frequency synthesizer, spectrum analyzer, programmable read-only memory (PROM) burner/verifier, and manual microprocessor consoles. The contractor also owns and uses a line printer, high-speed paper tape reader/punch, and the requisite software to edit and compile programs. The detection, isolation, and repair of system and component faults is contingent on the availability of these equipments and software packages.

INSTRUCTION MANUALS. Only draft copies of the first three volumes of the instruction manuals were available during the evaluation. Schematics, wiring diagrams, and preventative maintenance manuals were to be delivered at a later date along with program listings for the microprocessors.

Maintenance personnel worked with several sets of schematics and wiring drawings which were accumulated during the construction and installation of the system. As a result, there was no guarantee that engineering changes were incorporated in all drawings.

There was no systematic procedure to follow in regenerating the computer system following a failure or accidental memory erasure. At least two of the maintenance personnel had their own procedure to follow. On two occasions, they were called at home by the operating personnel for instructions.

The system includes several pieces of equipment that have moving parts. Teletypes, fans, and discs should all be covered by a preventive maintenance procedure which has yet to be delivered. Procedures are also needed to maintain the lead calcium cells for the UPS.

TRAINING. In evaluation review of the TCSS training program, a training procedure was determined. Airway facilities personnel receive a 1-month General Automation maintenance course. Three more classes are scheduled in the following sequence: first, hardware, software, and private automatic branch exchange (PABX); second, UPS; and third, hardware and PABX. These classes, in addition to on-the-job training during the period of contractor maintenance support, will provide Airways Facilities (AF) with the requisite skills to maintain the system and adapt it to changing requirements.

TECHNICAL MANAGEABILITY.

Evaluation of technical manageability was accomplished as identified in the following areas.

RECONFIGURATION FLEXIBILITY. A terminal system must include good flexibility and growth capability for application in the Upgraded Third Generation (UG3rd) ATC communications system. TCSS computer-controlled reconfiguration provides this flexibility. The TCSS can be reconfigured in less than 8 seconds under central processor control from 10 available configuration maps. The processor can also reconfigure individual positions and sectors and provide special ATC functions. When being configured, the affected portion of the system is under control of the position microprocessors.

MAINTENANCE LOGISTIC RECORDS. At the time of the evaluation, maintenance was being performed by the manufacturers field engineering group. Failures were recorded by unit, failure and serial number.

Tests of spare parts usually resulted in many erroneous indications of failures to the point where teletype printouts were not then utilized. Working spares were used to replace defective modules. If such modules could not be repaired locally, the spare unit was returned to the factory for repairs.

Detection of a fault by the RTQC causes a light to be activated on the monitor panel associated with the faulty position or module, a printout of the time and the number of the light, and an aural alarm. The teletype printouts were not utilized during the evaluation period because tests of spare parts usually resulted in many erroneous indications of failures.

COMMUNICATION TRAFFIC DATA COLLECTION. The RTQC does not record failure indications on magnetic tape or disc for computer analysis. TDC programs were operated and printouts reviewed to evaluate their usefulness as a tool to determine controller communications workload. It is initiated via the system teletypewriter by entering a simple start command. Upon initiation, the TDC program writes several header records on the magnetic data tape. These records include the start time and date, and the look-up tables and pointers for the current system configuration. The operating program generates time marks in four-digit hexadecimal code and records them along with the traffic data.

Every IA, DA, and radio pushbutton activation sends a discrete eight-bit message through the associated RME modem and multiplexer (MUX) to the central processor along with an eight-bit MUX line identifier. The messages are stored in a 400-byte record buffer with "FFFF" time marks interspersed at 1-second intervals. At the end of each minute, the current record buffer is filled with a series of "EEEE" minute marks and written on the magnetic tape.

The FAA team wrote two data reduction programs which can be executed on the offline computer. The first program prints out the time, position that initiates the action, the action, and the position, or the trunk, or the voice-call mnemonic, or the radiofrequency or the IA number to which the action applies.

The second program prints out tallies of DA, IA, radio selection, and push-to-talk actions that have taken place over the previous hour. It also prints out the total time during that hour for which the push-to-talk was depressed and the total number of all types of pushbutton pressing actions. Actions are tallied for every active position each 10 minutes. Start and stop times are entered via an operator input device prior to reading the data tape. Printout is generated only between those times.

The TDC program as specified in the engineering requirement was to have recorded uncompleted calls and the reason for call rejection. These data were not collected because they were not sent out over the monitor TRS's to the RME modems. The data exist in the system as handshake information between calling and receiving modems. A calling position sends an "X" identification code and type-of-call code when it attempts to establish a call. The receiving modem responds with a call-connected code or other appropriate codes, such as busy or calls in queue. The calling modem will repeat the calling code three times if the first two codes do not elicit a proper response. These handshake data are only sent out via the home and calling TRS's and are not detected by the monitor TRS's. Without the handshake data, it is impossible to write a data reduction program that can list uncompleted calls.

The TDC program implementation results in many erroneous records in which either the MUX number or the button code is undecipherable. Octal and hexadecimal dumps of sample data tapes were performed to verify that the errors are in the recordings and not the data reduction programs. The TDC timing messages were also found to be faulty. Elapsed time, which is calculated by counting timing marks, has been in error by as much as a minute over a 12-hour recording period.

Global reconfiguration automatically stops the TDC program and writes an end of file onto the data tape. TDC must be restarted manually. There is nothing to prevent an operator from starting the program while it is running. This causes new header data to be written in the middle of the data. The header records generate pages of erroneous printout.

EXPANSION POTENTIAL.

Investigation of the expansion potential brought out the capabilities in the following areas.

SPECTRUM AND CHANNEL UTILIZATION. Expansion potential is limited to basic design constraints in the use of the RF spectrum. TCSS synthesizers, transmitters, receivers, and RF amplifiers are designed to operate at frequencies between 10 and 15 MHz. One reference signal at 5 MHz is also transmitted over the coaxial cables. Single-sideband-suppressed carrier modulation is employed; local carriers are derived from the 5-MHz references. A 10-kHz channel spacing is used to transmit a 3-kHz-bandwidth voice signal and a frequency shift keying (FSK) data signal with 4-kHz spaces and 4.3-kHz marks.

Transmitter/receiver pairs operate with a 2.5-MHz separation for duplex transmission (figure 7). High- and low-pass filters with a crossover at 12.5-MHz provide isolation between high- and low-band signals. The 42 channels between 12.27 and 12.70 MHz are not utilized, because of the filter rolloff characteristics in that region. Both high- and low-pass filters attenuate approximately 16 dB from the pass bands at 12.5 MHz. The 42 complementary channels are also unused.

There are 416 channels available for communications. TCSS uses 306 channels to support 38 positions, 11 SS-1 lines, 20 voice call lines, 6 single frequency approach (SFA), 36 RF, 2 private branch exchange (PBX) lines, 1 order-wire service, and 1 RTQC modem. Each position requires two channels for the home TRS and two channels for the monitor TRS. All other functions are served by a single TRS using two channels. There are 110 usable channels which remain for expansion. Eighty channels can be used for additional positions using the TCSS addressing format. The system can be expanded to 58 ATC positions with an additional 15 trunks or remote radio controls.

CENTRAL PROCESSOR UTILIZATION. Each of the central processors is equipped with 16k of 16-bit memory which can be increased to 24K without adding wiring. The TCSS edit program and general automation disk-based operating system (DBOS) fill almost all of the 16k memory. Maps of core utilization were not available,

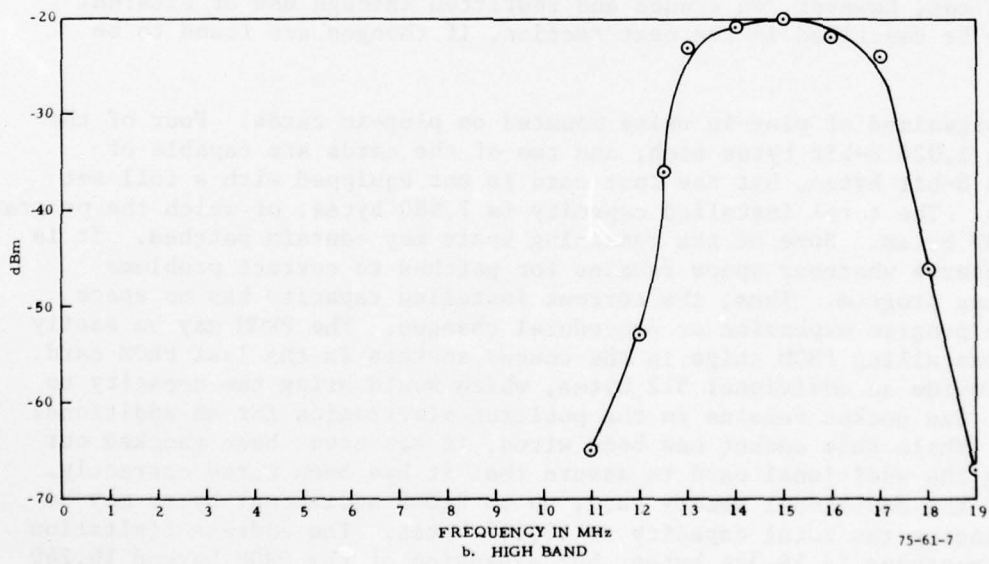
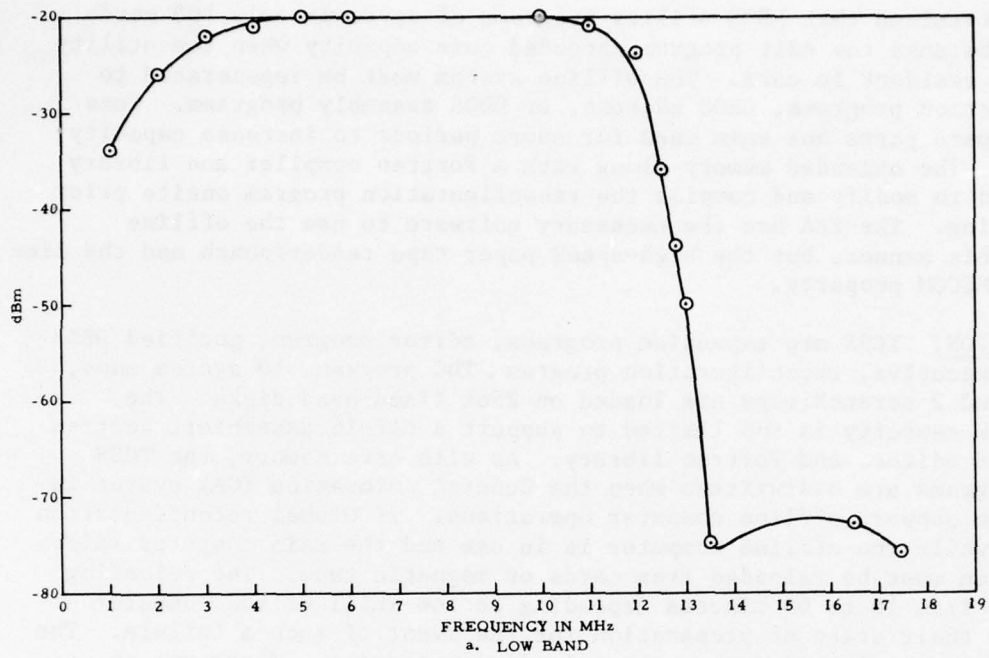

FIGURE 7. COMBINED FILTER RESPONSE FOR HIGH- AND LOW-BAND SEPARATION

but it was determined that DBOS utility programs of approximately 100 words were removed because the edit program exceeded core capacity when the utility programs were resident in core. The offline system must be regenerated to run data reduction programs, DBOS editors, or DBOS assembly programs. Core memory from spare parts has been used for short periods to increase capacity to 24k words. The expanded memory along with a Fortran compiler and library have been used to modify and compile the reconfiguration program onsite prior to commissioning. The FAA has the necessary software to use the offline computer in this manner, but the high-speed paper tape reader/punch and the line printer are AMECOM property.

DISK UTILIZATION. TCSS map expansion programs, editor program, modified DBOS monitor and executive, reconfiguration program, TDC program, 10 system maps, 1 test map, and 2 scratch maps are loaded on 256k fixed-head disks. The remaining disk capacity is too limited to support a CAP-16 assembler, Fortran compiler, DBOS editor, and Fortran library. As with core memory, the TCSS operating programs are overwritten when the General Automation (GA) system is regenerated to support offline computer operations. If Global reconfiguration is attempted while the offline computer is in use and the main computer fails, the TCSS system must be reloaded from cards or magnetic tape. The reloading process takes from 10 to 60 minutes depending on the skill of the computer operators and their state of preparation for the event of such a failure. The TCSS cannot be reconfigured during the reloading operation. There was no written step-by-step procedure to guide the operator in regenerating the system.

PROM UTILIZATION. The program steps that control the position electronics microprocessor and cause it to execute its required functions are permanently stored in the Programmable Read Only Memory (PROM). Information stored in the PROM cannot be changed by the user processor or by turning OFF the power supplies. It can, however, be erased and rewritten through use of external equipment, to be described in the next section, if changes are found to be required.

The PROM is organized of plug-in units mounted on plug-in cards. Four of the cards contain 1,024 8-bit bytes each, and two of the cards are capable of holding 2,048 8-bit bytes, but the last card is not equipped with a full set of PROM units. The total installed capacity is 7,680 bytes, of which the program occupies 7,589 bytes. Some of the remaining space may contain patches. It is prudent to reserve whatever space remains for patches to correct problems in the existing program. Thus, the current installed capacity has no space remaining for program expansion or procedural changes. The PROM may be easily expanded by installing PROM chips in the unused sockets in the last PROM card. This would provide an additional 512 bytes, which would bring the capacity to 8,192 bytes. One socket remains in the position electronics for an additional memory card. While this socket has been wired, it has never been checked out by installing the additional card to assure that it has been wired correctly. By installing the additional memory card, up to 2,048 additional bytes may be obtained, bringing the total capacity to 10,240 bytes. The address limitation of the microprocessor is 16,384 bytes, but expansion of the PROM beyond 10,240 appears to be impractical, because it would require an extensive redesign of the position electronics logic to consolidate functions to provide the physical space required.

RAM UTILIZATION. The Random Access Memory (RAM) consists of eight plug-in chips which contain 1,024 separately addressable bits each. By addressing all eight RAM chips simultaneously, an 8-bit byte is extracted from memory and rewritten. The RAM chips are mounted on the first four PROM cards.

The RAM is used to store tables of configuration data (such as the channel assignment for each DA pushbutton) and status information that may be needed by the program at a later time.

For these tables, 401 bytes of memory space have been allocated. The table sizes were assigned assuming maximum system expansion. For instance, the DA pushbutton status tables provide space for 24 DA pushbuttons; whereas, the system has only 18 assigned at each position. The tables are packed as tightly as possible based on the current numbering plan limitations. For instance, since the channel assignments for ATC positions are limited to those frequency numbers which do not include "8's" and "9's," each digit can be expressed in three bits instead of four. Furthermore, since the most significant digit is limited to 1, 2, 3, or 4, that digit can be expressed with only two bits. These limitations allow the channel assignment for each DA pushbutton to be expressed in a single 8-bit byte.

The remainder of the RAM (623 bytes) is available as working space. One such use is to buffer reconfiguration information that must be relayed to the radio module, the DA module, and the junction module at a higher data rate. The amount of RAM that is used for such purposes varies through the program. The opinion of the programmers is that at no time during the operation is a significant amount of the RAM used for such working space.

It may be concluded that about half the RAM capacity is available for functional changes and/or expansion.

ELEMENTS NEEDED TO CHANGE THE MICROPROCESSOR PROGRAM. Several characteristics of the TCSS position electronics microprocessor make it difficult to modify the program:

1. The program is contained in read-only memory which cannot be rewritten by its processor.
2. The processor has no console and no means for halting the program and examining or changing the contents of its registers.
3. No compiler is available. The program must be written in a mnemonic form for assembly on a general purpose processor. In theory, once the program is completely checked out, it should not be necessary to change it in any way. From a practical standpoint, however, it may become necessary to make changes after the system is operational for several reasons:

- a. Often a "checked-out" program still contains defects which occur at such a low recurrence rate that they are not recognized as problems until after several months of operation.

b. After some period of operation, it is likely that changes in operating procedures are found to be desirable and that changes in the program are needed to support them.

c. After some period of operation, expansion of the system may be found to be necessary, and changes to the program may be needed to support that expansion.

The contractor's experience in programming the microprocessor has shown that the following items are needed:

- Trained programmers,
- Program documentation,
- Programming aids,
- A key punch,
- An assembly processor,
- A PROM burner,
- A check sum generator, and
- A manual control unit.

Appendix D provides some additional description of each item.

MECHANICS OF EXPANSION.

The system can be expanded to 58 positions, but the addition of even two positions will require the installation of many ancillary pieces of equipment. For instance, to add two positions with 12 radios in the TRACON will require the following additions:

1. Twelve TRS's for radio,
2. One junction module or modification of JM-12 to accept additional radios (one position could be added to JM-5),
3. Dual PE power supplies,
4. A new rack in the equipment room for JM and power supplies,
5. Cards in the voice-call switching matrix,
6. RME modems,
7. Connections to the MUX,
8. Cabling to voice-call matrix, junction module, and power supplies, and
9. New maps.

The addition of a tower radio position would require similar system changes. In short, the system could have been larger at the time of installation with only an incremental increase in cost. Now that the system is commissioned, it is unlikely that operational requirements will ever justify expansion in the number of positions.

DETERMINATION OF FUNCTIONAL OPERATING CHARACTERISTICS.

During evaluation, the following functions were operated and performance observed as indicated.

CALL FORWARDING. Calls can be forwarded from any position to any other position by keying IA3-XXX on the dialer module, where "XXX" is the call number of the position to which the calls are forwarded. Calls in progress and calls in queue are not forwarded, because the call-initiating handshake information has already been processed. Calls in progress are terminated, and calls in queue continue to receive a ring-back signal in spite of the fact that calls in queue cannot be answered or dropped at either the forwarding or forwarded positions. The caller must disconnect the call and recall to establish communications at the forward position. Voice calls and radiofrequencies are also unforwardable, as neither makes initial contact through the home TRS of the forwarding position. Presumably, calls will only be forwarded to positions sharing the same voice-call and radiofrequencies.

Call forwarding is cancelled by keying IA3 on the dialer module at the forwarding position. All other DA, IA, and radio module pushbuttons are ineffective during a call-forward condition.

OVERRIDE CALLS. Override calls are placed by pressing properly configured DA pushbuttons or keying IA1-XXX on the dialer module where XXX is call number of the overridden position. The overriding position unilaterally establishes a two-way communication path with the overridden position and all other positions that are communicating with the overridden position by intercom or interphone. The overriding position can also hear the overridden position radio transmissions, but not the aircraft radio replies. The overridden position can disconnect the call by keying IA7000 on the dialer module. Normally the call will be disconnected by the overriding position by pressing the DA button a second time or pressing any other button which is used to initiate a call. Override calls can be used to establish conference calls for several positions in two ways: Either every conferencing position can override the same position, or the overridden positions can bring other positions in on the call by overriding them. As installed, the TCSS was limited to three or four positions on a conference, because each additional conferee added to the background noise until speech was unintelligible. Automatic gain control (AGC) levels were modified after the site acceptance tests for several reasons. One result of the modification was to effectively eliminate the buildup of background noise as more positions are added to a conference.

RADIO SELECTION. All main standby indicators are switched to MAIN (figure 8) when reconfiguration is performed. The associated radio modems are not switched. A frequency must be selected with the transmitter SELECT push-button (XMTR) and then the MAIN pushbutton for receiver or transmitter must be pressed to determine if the receiver or transmitter is really switched to MAIN. If they are in MAIN, the indicators will switch to STANDBY; if they are in STANDBY or if there is no STANDBY available, they will continue to indicate MAIN. Switching from MAIN to STANDBY at one position changes the indicators at all positions that are configured to use the same frequency.

CLEAR ALL CALLS. Keying IA7000 disconnects all intercom, interphone, and monitor calls to the position. This feature can be used to clear the position for reconfiguration in the event that an override call has not been disconnected by the calling position due to malfunction or oversight.

AUTOMATIC RECONFIGURATION. Automatic reconfiguration takes place whenever power is reapplied to a position and, under certain transient conditions, by sending an "F4" reconfiguration request to the RME modem. Some microprocessor timing problems that sent random spurious codes to the RME corrected themselves by sending an "F4." There are only 256 possible two-digit hexadecimal codes that can be sent. With over 1,000 codes per minute being transmitted to the RME by the microprocessor, it was inevitable that an "F4" was sent sooner or later.

INTERFACES.

TCSS interfaces physically with commercial power, telephone company lines, and FAA air/ground communications equipment. The conditioning of all interface power and signals is accomplished within the TCSS system by the UPS; SS-1, SFA, voice call, and PBX modems; and, by the radio modems and radio distribution networks.

COMMERCIAL POWER. Primary power for the system is 3-phase, 60-Hz, 120/208 volt, four-wire. The operating system uses 43.2 kVA. Power is available from two substations and is routed to the TRACON from opposite ends of the field. Backup power is supplied by an engine generator in the TRACON if commercial power is lost for more than 2 minutes. The UPS will support TCSS for 1 hour in the event that both commercial and backup power are lost. UPS rectifies the input power to 360 volts to float the sustaining lead-calcium cells (figure 9) and power a 3-phase inverter. A line voltage regulator is automatically switched in place of the static inverter in the event of rectifier or inverter failure. All system loads are single-phase 110-volt loads distributed over the three phases to present an approximately balanced load to the inverter. Clamp-on ammeter readings for the three phases with the system loaded were 60, 56, and 48 amperes. Neutral current was 105 amperes. Fourteen turns of single strand 32-gauge wire were wrapped around the neutral wire loaded with a 600-ohm resistor and viewed on an oscilloscope (figure 10) along with the phase 1 to neutral voltage. It was determined that all of the TCSS power supplies are full-wave bridges with a capacitive input filter. They only draw current from the power source when the line voltage exceeds the capacitor voltage. The

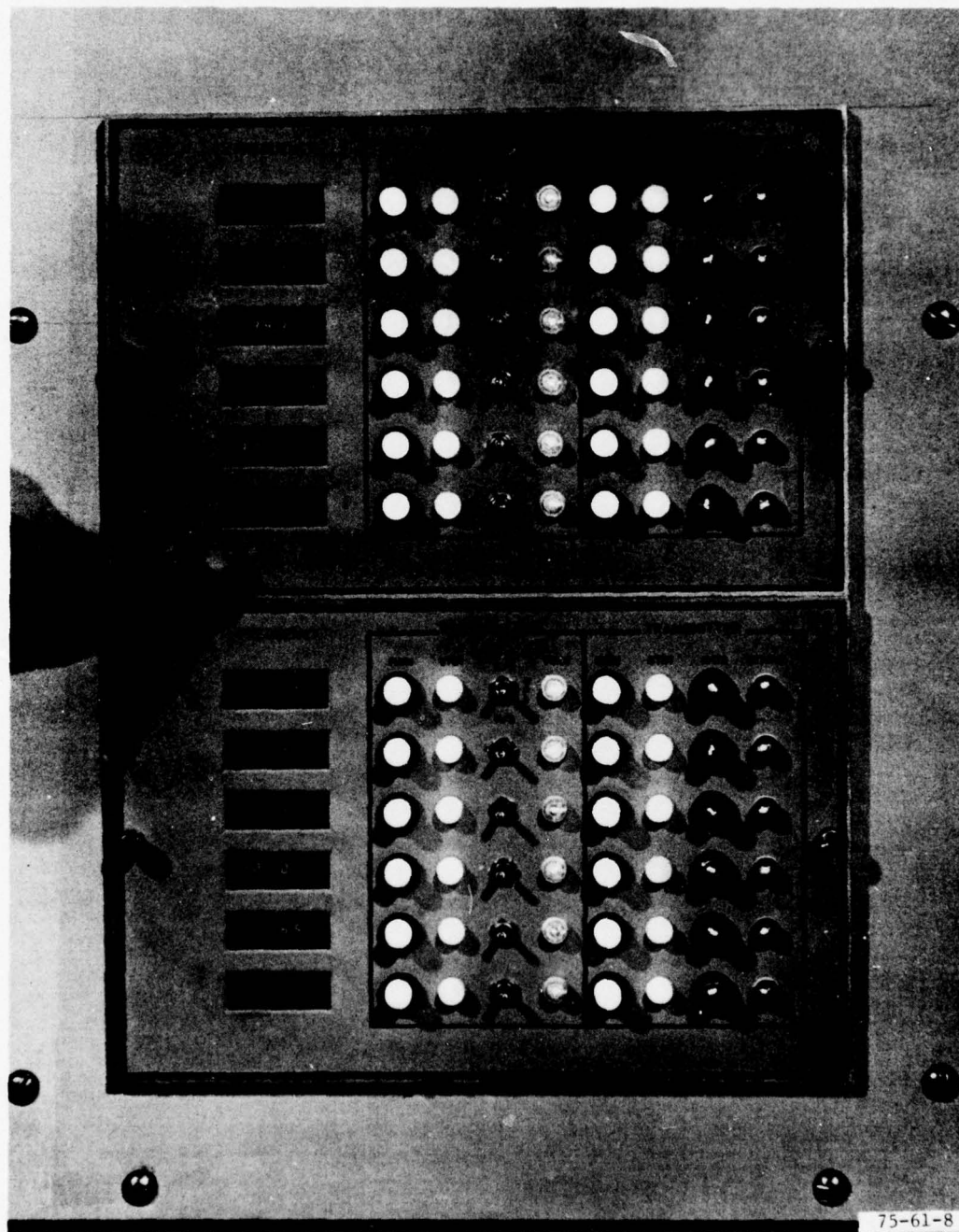

FIGURE 8. TCSS RADIO SELECTOR PANELS



FIGURE 9. UPS LEAD-CALCIUM BATTERY CELLS

net result of all of the power supplies and the GA computer loading is that the system draws the 200-ampere limiting current from each phase for about 70° each half cycle. There is very little cancellation of currents in the neutral wire and measurements taken with test equipment are misleading. Power factor is meaningless with the waveforms involved. The heavy neutral currents cause a 180-Hz voltage to exist between the TCSS power grounds and commercial power grounds in the TRACON. The distorted wave shape from the current limiting in the UPS and line voltage regulator (LVR) result in high harmonic distortion (figure 11 and 12) compared to the commercial power (figure 13). TCSS operation reflected no adverse effect from this harmonic distortion. An independent ground circuit isolates the TCSS from other TRACON systems.

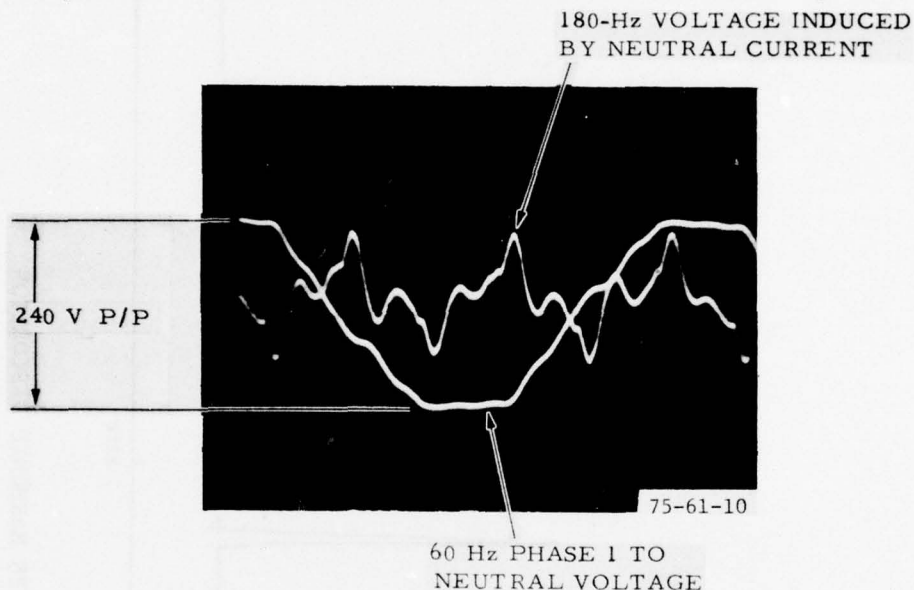

FIGURE 10. PHASE 1 TO NEUTRAL COMPARISON

TELEPHONE LINE. A Nippon Electric Company Ltd. NA4-09 PABX and two PABX modems are used to provide interface with the support phones and trunks. Positions can be class marked to prohibit PABX access and direct dialing capability. Class marks are also available to prohibit access to Federal Telecommunications System (FTS) when it becomes available. The two trunks can be keyed in by dialing IA2 plus the three-digit line code from the IA module at positions that are class marked to allow access. A ring-up feature automatically selects the second trunk if the first is busy.

Voice-call modems, the voice-call switching matrix, and the RME modems provide the interface with General Telephone and Electronics (GTE)-leased voice-grade lines. There are 20 voice-call modems. Outgoing connections are established through the DA modules or by dialing "4" plus the voice-call modem frequency on the IA module.

The six SS-1 lines are accessed by dialing "5" plus the SS-1 line modem/frequency plus the identity (ID) of the called facility.

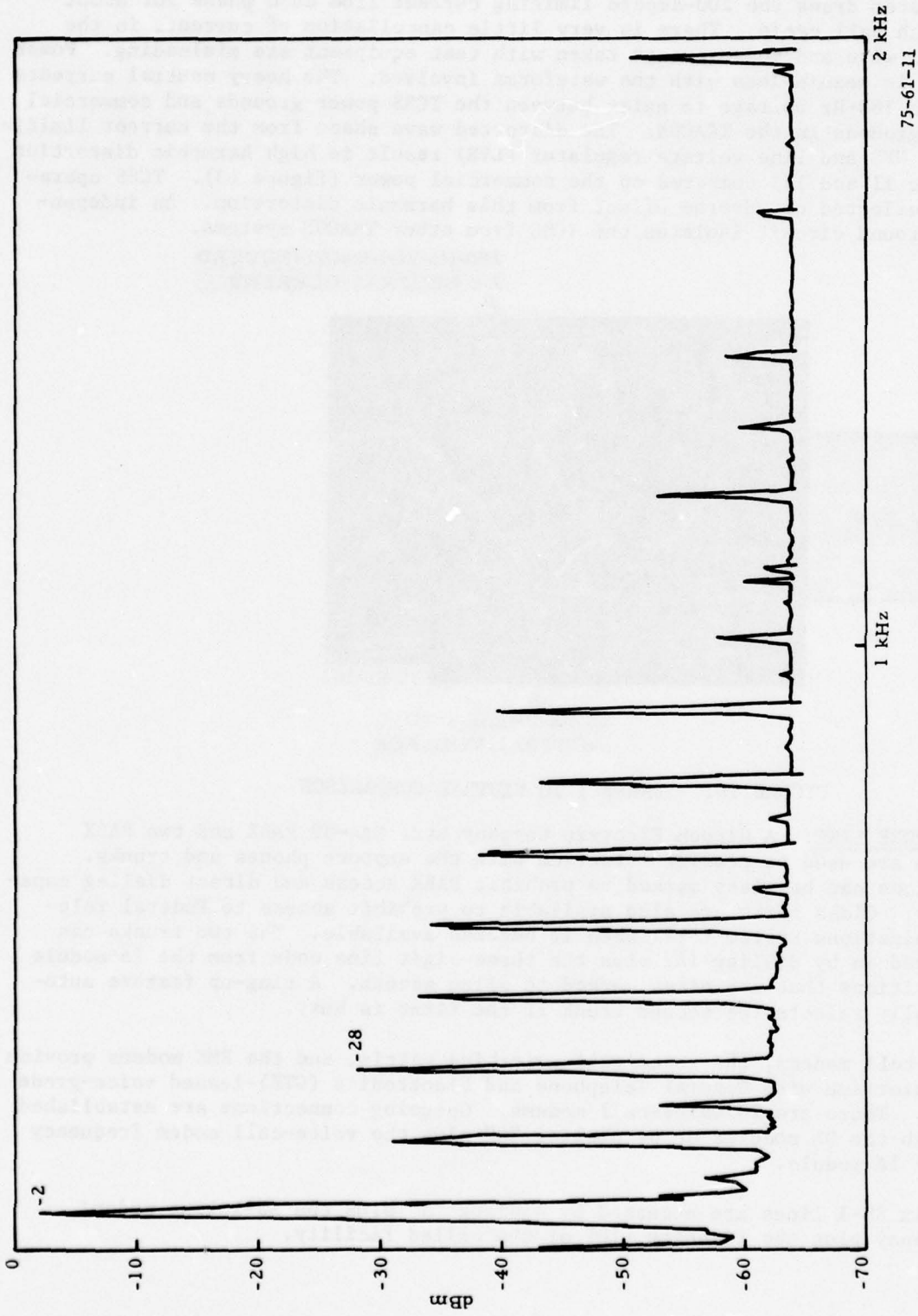

FIGURE 11. UPS HARMONIC DISTORTION

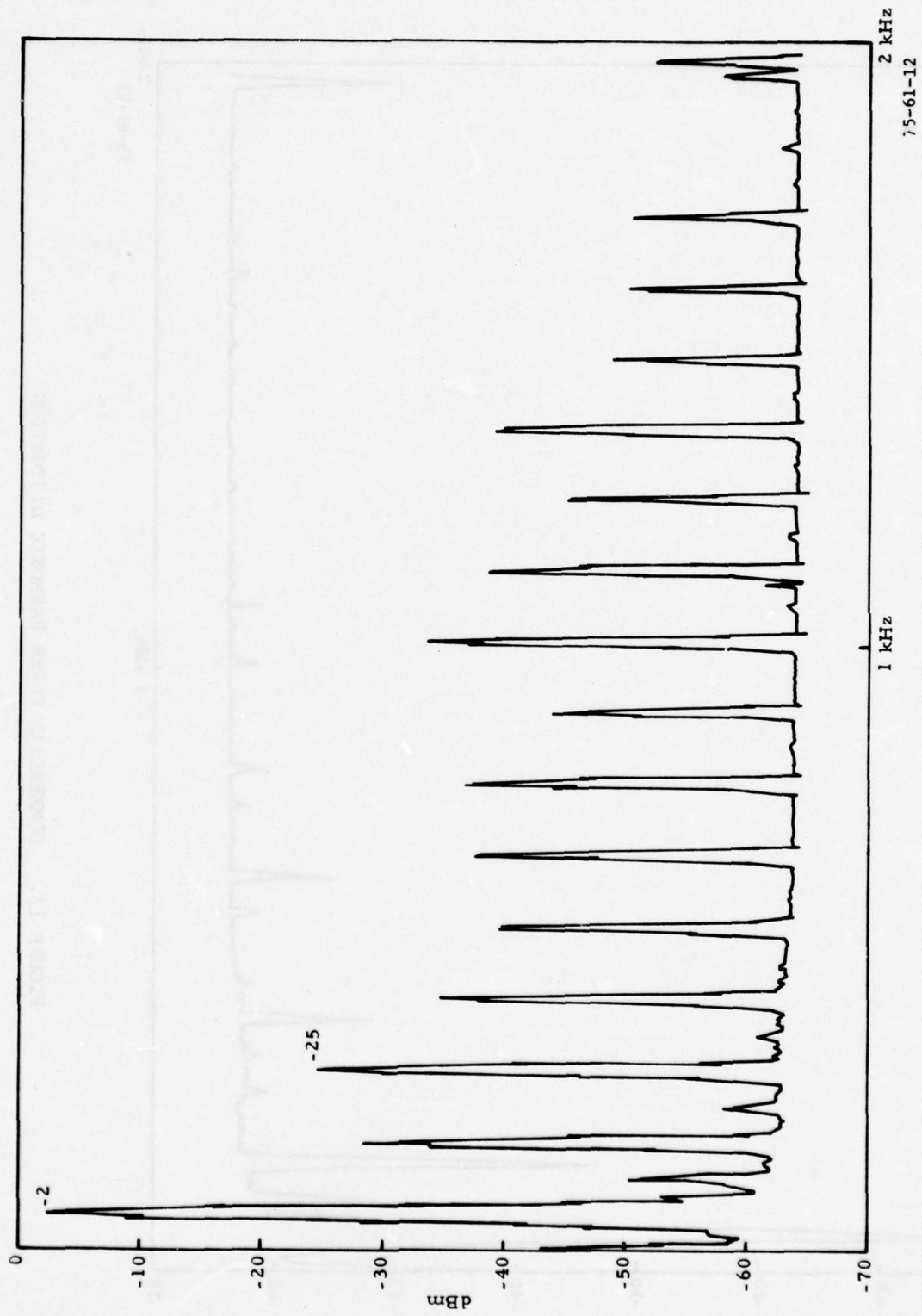

FIGURE 12. LINE VOLTAGE REGULATOR (LVR) HARMONIC DISTORTION

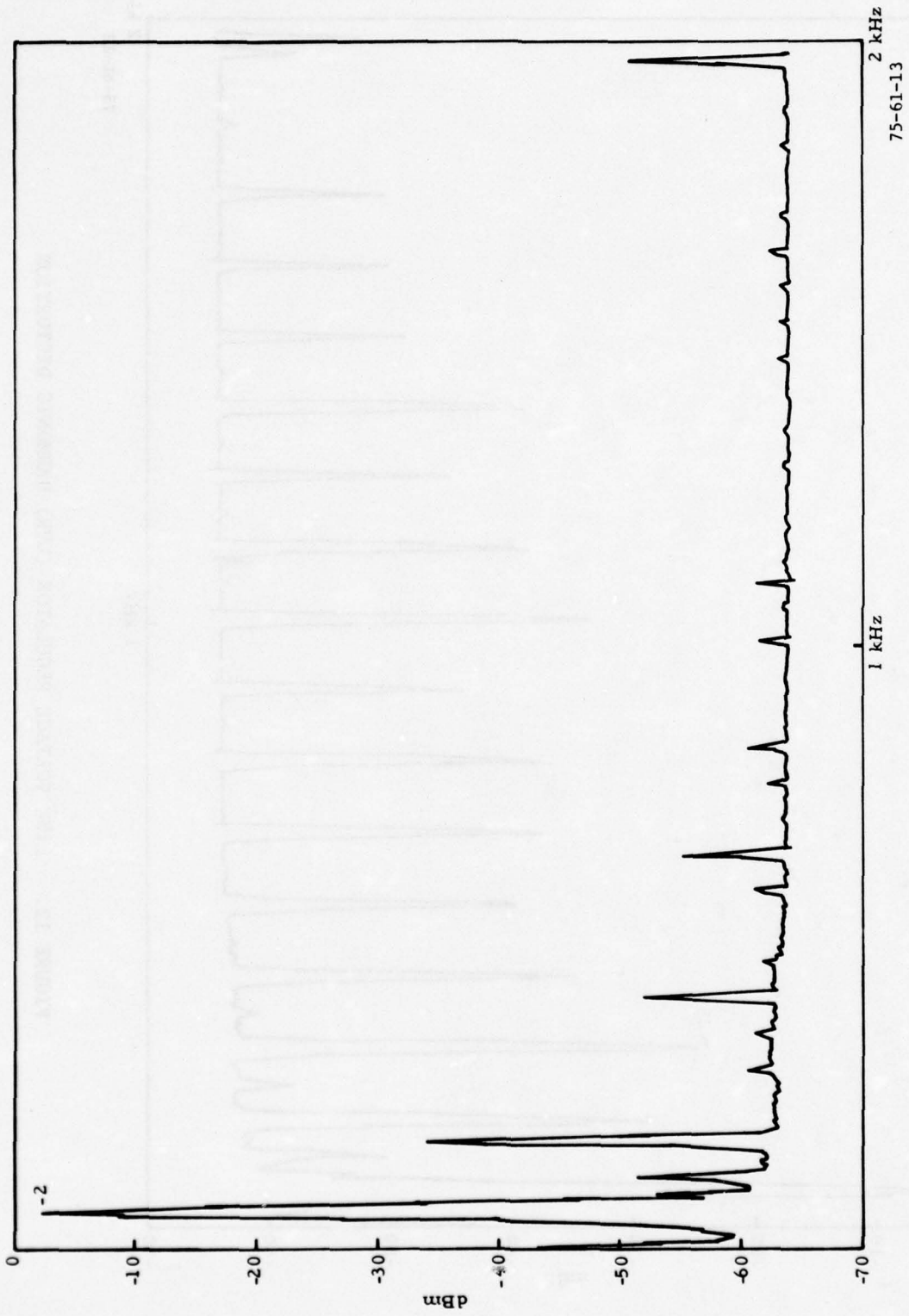

FIGURE 13. COMMERCIAL POWER HARMONIC DISTORTION

Single-frequency approach modems are accessed only through the radio modules at the positions. They transmit the push-to-talk information as well as voice signals to receiver transmitter pairs at other facilities.

The TCSS side of all of the interfaces with GTE lines was checked for impulse noise, crosstalk, intermodulation, harmonic distortion, and signal levels during the site acceptance test.

REMOTE RADIO SITES. Interface with the FAA air/ground receiver/transmitter equipment is through the modems at the remote sites and a hard-wired distribution network between the receiver and the transmitter buildings on each side of the field. A single coaxial cable connects each side of the two remote radio sites to the junction modules in the TRACON equipment room. Failure of one of the cables disables all of the equipment on one side of the field. Each cable has two associated line amplifiers and hybrids to compensate for cable attenuation and provide full-duplex operation. The amplifiers provide more than enough gain and additional attenuation has been added to the cable to adjust the signal level to the design operating point of the amplifiers. All of this additional attenuation was removed during the evaluation without overloading the amplifiers or interfering with the out-of-band frequency shift keying (FSK) control signals. As a further test, the attenuation was increased from 10 dB on one cable and 6 dB on the other cable to 25 dB on both without interfering with signalling or receiver quality. Further increase to 30 dB on each cable prevented switching from MAIN to STANDBY and deteriorated receiver quality. The transmitters were not connected and therefore were not included in this test.

SAFETY.

Physical injury, electrical shock, battery explosion, burns from excessive temperature, sound levels, and fire hazard were considered as major items of evaluation under this area.

PHYSICAL INJURY . Operating personnel have bumped their heads on the tubs above the horizontal positions. These tubs have unpadding corners directly over the displays. Caution is necessary, when standing erect after bending over the display, to prevent hitting the back of the head on the tub.

Other potential hazards are the swing-out speakers on the sides of the tubs. They present hard, sharp edges at eye level to people taller than 6 feet. To date, no one has received an injury from this source, but the probability of injury will be higher in an operating environment.

Maintenance personnel working on the tubs must stand on a step ladder to remove position electronics modules that weigh in excess of 35 lbs. No scaffold is available to provide a stable working platform.

ELECTRICAL SHOCK. Operating personnel are remote from all of the high-voltage elements of the TCSS. The highest voltage at the operating positions is +15 volts, and even that voltage is not present on the face of the equipment.

The system does have a 350-volt battery bank as part of the UPS with exposed bus bars capable of sustaining lethal currents. The three-phase power systems are entirely enclosed in conduit, breaker panels, and ducting and do not present a hazard.

BATTERY EXPLOSION. The lead calcium cells were checked for hydrogen emission prior to the evaluation and determined to be safe in the area. Their capacity is so large that a short circuit in the inverter is not likely to damage the batteries before tripping the breakers.

BURNS. No part of the system that is exposed to the operators has a temperature which causes discomfort or injury. The highest temperatures measured were less than 60° centigrade (C) and these were inside of equipment enclosures.

SOUND LEVELS. Sound levels were measured in the TRACON and in the equipment room. Measurements were made with all equipment operating, but without noise from radios or ATC communications in progress. The noisiest location found was directly behind the UPS cabinets, where it reached 82 dB with a C weighting on a General Radio sound-level meter. Baffles have been designed and built to lower the noise from the fans in the UPS. It is estimated that they will lower the noise to approximately 78 dB with C weighting. One such baffle was installed during the test, resulting in a 2 dB reduction in noise.

FIRE HAZARD. The operating position modules and position electronics are mounted in wooden consoles. However, it is not considered that they add to the fire hazard, because they have a low temperature rise (maximum 25° C above ambient) and derive their power from individual low-current sources rather than from a single high-capacity source.

TECHNICAL SUMMARY OF RESULTS.

1. The TDC recorded erroneous messages and failed to record handshake data.
2. Quality control on spare parts was inadequate, and some were returned from the factory in an inoperative condition.
3. Modulation of the 5-MHz frequency standard translated throughout the 10-15 MHz frequency band modulating all intelligence signals.
4. Central processor core and disk memory capacities were inadequate to support offline functions.
5. The TCSS could tolerate up to 25 dB of signal attenuation or noise increase before serious deterioration of performance resulted.
6. The combination of UPS current limiting and power supply capacitive filtering distorted the input wave shape and caused high harmonic distortion.
7. Equipment room noise level was measured as 82 dB with a C weighting. The TRACON worst-case noise level was measured as 76 dB with a C weighting.

8. Cable faults could not be satisfactorily located with the present test equipment.

9. Modules (DA, IA, radio, etc.) were not "plug-in," instead they were mounted in the console employing removable connectors.

10. The voice-call switching was not redundant.

11. Trouble reports are not written on mag tape or disc in accordance with ER paragraph 3.4.10.

12. The system in its present configuration was not capable of debugging programs or modifying the system program. The microprocessor program was difficult to modify.

13. An average of 2.4 hardware failures per day were recorded during the test period.

14. The maintenance manuals were not available.

15. An excessive number of pushbuttons were broken during the test.

16. The system could have been larger at the time of installation with only an incremental increase in cost. Now that the system is commissioned, it is unlikely that operational requirements will ever justify expansion.

17. Distribution of PE's through junction modules resulted in undetected faults.

CONCLUSIONS

Based on the foregoing operations and technical test results, the following conclusions are submitted concerning the evaluation of the TCSS.

1. TCSS test and evaluation was handicapped by installation of this first system in an operational environment rather than a suitable test facility.
2. Within the constraints of the operational environment existing during its test and evaluation, the TCSS satisfied the combined radio, interphone, and intercom communications functional requirements for the air traffic controller in a terminal area complex such as the DFW terminal area.
3. As the result of satisfactory performance by this system during evaluation, the TCSS is considered a viable candidate system for future procurements.
4. The following changes or modifications are concluded as necessary to accommodate application of the TCSS to future terminal environments:
 - a. Replace control tower LED's with indicators that can be read in areas of high ambient light.
 - b. When overriding a radio position, make it possible for the caller to hear radio receivers.
 - c. On the "call forward" function, include voice calls in the transfer of communications.
 - d. Reduce or eliminate time delay on status indicator lights.
5. The voice quality of the radio and interphone circuits is considered above average.
6. The TCSS is a more flexible system than the one now in use by the controllers.
7. The TCSS positions are not considered complex to operate.
8. The operation of the TCSS is easily learned over a short period of time.
9. The TCSS can be expanded to a maximum of 58 positions.
10. Through reconfigurations, spare positions can be used to replace failed positions while repairs are being effected.
11. The voice-call switching matrix is a nonredundant element and disables all voice calls when it fails.

12. The TCSS is under contract maintenance (until May 22, 1976), and the FAA did not have sufficient trained personnel or facilities to maintain the system, as of June 1, 1975.

13. An available frequency synthesizer can be used as an emergency TCSS standard if both system references fail.

14. Present cable connectors on the rear of modules hinder their replacement and are subject to failure after repeated module replacement.

15. The speaker modules and tubs for the horizontal positions can be a hazard to controllers. They project sharp corners and edges into the working area of the horizontal displays at the level of the controller's head.

16. When the TCSS standby processor is being used offline, and a reconfiguration is attempted, failure of the main processor can disrupt the system until standby is put back online and loaded with the TCSS operating program.

RECOMMENDATIONS

Based on results of tests concerning the technical/operational evaluation of the TCSS, the following recommendations are submitted:

1. As the result of satisfactory performance by this system during evaluation, the TCSS should be considered a candidate system for future procurement.

2. The questionnaire used in this evaluation should be completed again approximately 4 months after commissioning the TCSS. The purpose would be to better determine system reliability and to validate items pertaining to radio operation and voice-call circuits that could not be exercised extensively during the tests. (This recommendation has since been implemented. Results are documented in a separate data report.)

3. Modifications should be made to the TCSS system to correct the most objectionable features as encountered in the responses to technical evaluation.

a. Replace LED's, where required, with indicators that can be read in areas of high ambient light.

b. When overriding a radio position, make it possible for the caller to hear radio receivers.

c. On the "call forward" function, voice calls should be included in the transfer of communications.

d. Reduce or eliminate time delay on status indicator lights.

e. The lock-up condition for incoming voice calls should be rectified.

f. DR-1, DR-2, and SMC should be redistributed to function through JM-4, 5, and 6, respectively.

g. The pushbutton should be replaced with an improved version (shorter, more durable) as the need to replace occurs.

h. The speaker module for the horizontal positions should be modified to prevent possible injuries to controllers.

i. Padding should be added to the bottom of the horizontal display tubs.

4. The possibility of using a frequency synthesizer as an emergency system frequency standard should be investigated.

5. Reconfiguration should not be attempted with standby computer offline.

6. The utility of the RTQC printouts should be checked during 3 months of system operation by analyzing the records for that period.

7. The central processor should be enlarged to provide offline troubleshooting, data reduction, and program modification.

8. For future systems including processors, greater emphasis should be placed on procuring software rights.

9. All elements which are common to an entire function, such as the voice-call matrix, should be redundant or fail operable in future system.

10. Future specifications should clearly define plug-in modules to eliminate cable connectors.

11. The power system should be specified under system load instead of a pure resistive load.

12. To provide adequate maintenance capability, the FAA should procure or make available the following:

Frequency synthesizer,

Spectrum analyzer,

PROM burner,

Software package,

Line printer,

High-speed paper tape reader/punch,

Manual control unit,

Micrologic chips to maintain for the expected lifetime of the system, and

Schedule for preventive maintenance.

APPENDIX A

TCSS FUNCTIONS AND FEATURES

BASIC FUNCTIONS.

The terminal communication switching system (TCSS) provides four basic communications functions; namely, intercom, interphone, radio, and support communications.

INTERCOM. The intercom function provides the capability for communications between controller positions within the facility. Two types of intercom call are possible, ring-back intercom and intercom override. Ring-back intercom requires acceptance of the call, while intercom override provides the calling position with the capability to connect to the called position even though the called position is "busy." This is accomplished by automatic establishment of a conference connection whenever an override call is placed.

INTERPHONE. The interphone function provides the capability for communications between controller positions within the facility and external facilities. Interphone communications can be established with subscribers on the selective signalling (SS-1) network, with positions at remote facilities via external communications lines using voice signalling (voice call), and with subscribers on the support communications system (PABX call). The direct digit dialing (DDD) network can also be accessed by an ATC position via the private automatic branch exchange (PABX) interphone call capability.

RADIO. The radio function provides the capability for communications between controller positions and selected aircraft via remote transmitter receiver (RTR) site equipment. Radio transmission is accomplished via push-to-talk (PTT) operation, which incorporates a lockout feature to prevent transmission by more than one position at a time. Radio communications may be monitored (received) at a controller position on all selected channels simultaneously.

SUPPORT COMMUNICATIONS. Support communications capability is provided to supervisory and administrative personnel within the facility via the PABX. The PABX and instruments provide each subscriber with the capability to establish communications on a dial-up basis with any other subscriber, with any ATC position, and with external parties via access to the DDD networks.

OTHER. In addition to providing intercom, interphone, radio, and support communications, TCSS incorporates automatic reconfiguration, traffic data logging and voice recording to permit monitoring and modification of traffic load distribution, and a real time quality control monitor capability to maintain continual surveillance of subsystem and equipment operational status. TCSS system power is provided by an uninterruptable power supply (UPS) which provides a 1-hour battery backup to sustain the system during main-power outage.

TCSS PLACEMENT AND ANSWER FEATURES.

INTERCOM/INTERPHONE. The intercom and interphone communications functions provide a variety of call placement and answer features to permit rapid, unambiguous call processing.

1. Direct access (DA) calling is accomplished by depressing a single pushbutton to communicate with the party identified by the light-emitting diode (LED) display associated with the selected pushbutton. Ring-back intercom, intercom override, and interphone voice calls can be placed via direct access.

2. Indirect access (IA) calling is accomplished by pushbutton dialing, using the 10-digit dialer module provided at each position. All intercom and interphone calls can be placed via indirect access by dialing the subscriber number (intercom call), the trunk access number (interphone voice call), or the trunk access number followed by the subscriber number (interphone SS-1 and PABX calls).

3. Combined DA/IA calling is accomplished by first depressing a single pushbutton to access the interphone trunk identified by the LED display associated with the selected pushbutton, followed by dialing the desired subscriber number, using the 10-digit dialer. SS-1 and PABX interphone calls can be placed via DA/IA.

4. Whenever an intercom/interphone call arrives from a party identified on one of the LED displays on a DA panel, the associated DA pushbutton flashes to indicate the incoming call. The call is answered by depressing the flashing pushbutton.

5. Whenever an intercom/interphone call arrives from a party not identified on any LED display, the call is queued in the position common answer (CA) feature. The CA pushbutton (on the IA module containing the 10-digit dialer) will either flash or wink (faster blink rate than flash) depending upon whether there are one or two calls in queue, respectively. Calls in CA queue are answered by depressing the flashing or winking CA pushbutton.

OVERRIDE CALLS. Override intercom calls may be placed via DA or IA, and provide automatic call connection on a conference basis. Several positions can be simultaneously conferenced via override calling. Incoming override calls are indicated at the overridden position by the override indicator, a green lamp on the IA module, which flutters for the duration of the call.

RADIO. Each position with radio communications capability is provided with two or five radio modules, for access to 12 or 28 radio channels, respectively. Each radio module has up to six radio channel frequencies assigned, as indicated on the six-digit LED displays at the leftmost end of each radio panel. For each assigned channel, the controller at a position can independently enable transmit and receive capability, and can independently select main or standby transmitters and receivers.

TCSS FEATURES.

MONITOR. A monitor feature can be provided (via reconfiguration) at any position to permit that position operator (usually a supervisor) to monitor communications at other positions. Monitor connections are established on a receive-only conference basis. No indication is provided at the monitored position to indicate that the monitoring action is taking place. Two types of monitor are available:

1. The administrative monitor is a DA/IA feature which permits monitoring of voice communications at any position. Positions are selected for monitoring by dialing the desired monitor number on the 10-digit IA module.
2. The control monitor is a DA feature which permits monitoring of voice communications at preassigned positions. The monitor numbers for these positions appear on configured LED displays on the DA modules.

CALL FORWARDING. Capability is provided for any position to forward all incoming intercom and interphone calls to any other position. Call forwarding is initiated and terminated by dialing appropriate multidigit sequences, using the 10-digit dialer at the position which is forwarding its calls. This feature permits incoming calls to a vacated position to be directed to, and answered by, an alternate position.

CLASS-OF-SERVICE MARKING. Each ATC position within TCSS can be independently assigned class-of-service marking by the reconfiguration feature. These markings control position access to voice call, SS-1, and PABX circuits.

RECONFIGURATION. Flexible assignment of position traffic load is accomplished by the TCSS reconfiguration feature. This feature is provided by the reconfiguration and monitor element (RME) subsystem, which permits assignment and modification of communications capability for each of the facility ATC positions.

The RME stores up to 10 maps (system communications configurations), and upon RME operator command, transmits the data from the selected map to the control element (microprocessor) at each controller position. These data are presented to the ATC controller on the DA pushbutton and radio LED displays and appear as position ID name (for ring-back, override intercom, and voice calls) trunk identity numbers (for SS-1 and PABX interphone calls), special function codes, and channel frequencies (for radio communications). By this process, each position is configured for the specific communications capability contained in the selected map. In addition to configuring the DA pushbutton and radio LED displays, the map data transmitted to each controller position sets up the class-of-service markings, as previously described. During system reconfiguration, the RME also transmits map data to the voice-call matrix to establish the voice-call sectors.

Reconfiguration can be accomplished in one of three ways:

1. Global Reconfiguration. Upon RME operator command, configuration data from the selected map is transmitted to all system positions. Whenever any position has an intercom or interphone call in progress during reconfiguration, the RME monitors that position for call completion status and then transmits the appropriate map data. This procedure prevents interruption of communications at a position during reconfiguration.
2. Local Reconfiguration. This is similar to global reconfiguration except that map data is transmitted only to those positions selected by the RME operator.
3. Automatic Reconfiguration. Whenever a position is brought online (powered-up), the position microprocessor transmits a reconfiguration request to the RME. Upon receipt of such request, the RME transmits data from the current system map to the requesting position only. This is accomplished automatically, and requires no operator action.

All transmissions between the RME and the system positions are coded for error detection (parity, checksum, and bit position codes). Whenever a transmission error is detected, the RME reattempts the transmission. Up to three attempts are made, after which the RME informs the real time quality control monitor if transmission is still unsuccessful. The automatic reattempt feature permits successful reconfiguration in the presence of transient errors (such as noise-source errors), and automatically identifies the existence of steady errors (such as interface hardware failure), without requirement for operator intervention.

TRAFFIC DATA COLLECTION. Each depression of any pushbutton at a position to initiate, answer, or terminate a call is recorded by the RME. The microprocessor at each position transmits coded data to the RME, identifying the pushbutton depresses, and the RME formats these data, together with position ID, time-of-day, and current map number, and records the information on IBM-compatible 9-track magnetic tape. The recorded data can then be reduced, offline, to determine number of calls handled at each position, source, destination, time of placement, duration, etc., for each call. The results of the data reduction can then be used to determine if the distribution of traffic load per position (i.e., a new system configuration map) is required.

VOICE MONITOR RECORDING. Historical record of voice communications at each position is provided by multitrack magnetic tape audio voice recorders (GFE), located at the RME. The audio circuits at each position include a "tap" to transmit the combined intercom/interphone and radio conversation to the recording subsystem.

REAL TIME QUALITY CONTROL MONITOR. TCSS includes, as an integral feature, a real time quality control monitor (RTQC) which continually interrogates the system communications equipments for operational status. The RTQC periodically calls each position on the position's home communications channel and transmits a code requesting status. The called position, upon recognition of the request

code, transmits a response code back to the RTQC. If the RTQC receives a "status bad" code, an invalid code, or no answer at all, the information is recorded on a printout device (teleprinter), a failure status lamp for the tested position is illuminated on the RTQC front panel, and an audible alert is sounded to inform the system maintenance console (SMC) operator that a failure has been detected.

SPECIAL FUNCTIONS.

Several special features have been provided to aid the air traffic controller communications function.

CALL CONTROL. Any combination of five call control features can be assigned at each position during reconfiguration. These features are identified at the position by LED displays and are initiated by depression of the corresponding DA pushbuttons.

- | | |
|-------------------------|---|
| HOLD: | Provides the capability to place an incoming PABX call in hold, permitting any other call to be placed or answered without losing the held PABX call. |
| COMMON RELEASE: | Provides the capability to terminate any call in progress, except an incoming override call. |
| INCOMING CALL TRANSFER: | Three call control features provide the capability, subject to call-in-progress limitation, to direct specific incoming calls to either the position headset or loudspeaker. These features are headset/loudspeaker transfer (HL) and override headset/loudspeaker (OHL) for incoming intercom and override calls, and radio headset/loudspeaker transfer (RHL) for incoming radio communications on selected channels. |

POSITION TEST. Each position is provided with the capability for the operator to initiate tests to determine the functional status of the position controller (microprocessor) and the position communications interface. These tests are initiated by dialing specific digit sequences on the position 10-digit dialer. The position operator is informed, by audio tone, whether the position has passed or failed a selected test.

POSITION RESET. Each position is provided with the capability for the operator to release all calls at the position, including incoming override calls. This is accomplished by dialing a specific digit sequence on the position 10-digit dialer, which initiates release of most lock-up conditions at the position. (For example, an incoming override call which has not been terminated by the caller will prevent reconfiguration of the called position, until the call is released.)

ARCHITECTURE AND TECHNOLOGY. TCSS has been designed with an extremely high degree of functional and physical modularity to provide flexibility of system size (number of positions) and position capability (number of radios, DA modules, etc), as well as ease of maintenance. Because the TCSS communications capability of all position consoles, whether horizontal, vertical, or desktop, are provided by various combinations of the seven basic position modules, a uniform test and maintenance procedure is realized, and incorporates an economical spare parts inventory. The modularity of TCSS is further extended to the subsystem distribution, as well as the partitioning into voice communications (audio and radiofrequency) and control (digital). The circuitry employed in TCSS is primarily state-of-the-art solid state and integrated circuit electronics.

The fundamental communications design concept of TCSS employs distributed control and switching, with all voice, signalling and data multiplexed onto a redundant pair of coaxial cables. Frequency division multiplexing with dedicated channelization results in a nonblocking switching system, and communication via coaxial cable provides a bounded transmission medium which is isolated from the environment of the ATC facility.

SUBSYSTEM DISTRIBUTION.

The TCSS consists of six major subsystems which are, for the most part, functionally and physically distinct. These six subsystems are:

POSITION/JUNCTION MODULE SUBSYSTEM. This subsystem includes all controller position equipment which provides the intercom, interphone and radio communications capability to the controllers, as well as the junction module interface between each controller position and the coaxial cable transmission medium.

SYSTEM MAINTENANCE CONSOLE (SMC). The SMC (figure A-1) provides the system real time quality control monitor capability, with associated fault status indication and printout, and the maintenance communications position (MCP) capability by which the maintenance personnel can establish voice communications for information, monitor and test purposes.

RECONFIGURATION AND MONITOR ELEMENT (RME). The RME (figure A-2) is a centralized equipment group which provides the system reconfiguration and traffic data collection capabilities.

POWER SUBSYSTEM. This subsystem provides total TCSS system power, via an UPS as well as power distribution within the system via the power supply racks.

INTERFACE SUBSYSTEM. Provides all system interfaces to the RME and to external communications equipment such as interphone trunk circuits and RTR sites.

SUPPORT COMMUNICATIONS SUBSYSTEM. A private automatic branch exchange (PABX) provides administrative and support personnel with the capability to communicate among themselves, with TCSS ATC positions, and with external locations via the FTS and DDD networks. This subsystem also includes the order wire telephone at the RTR sites.

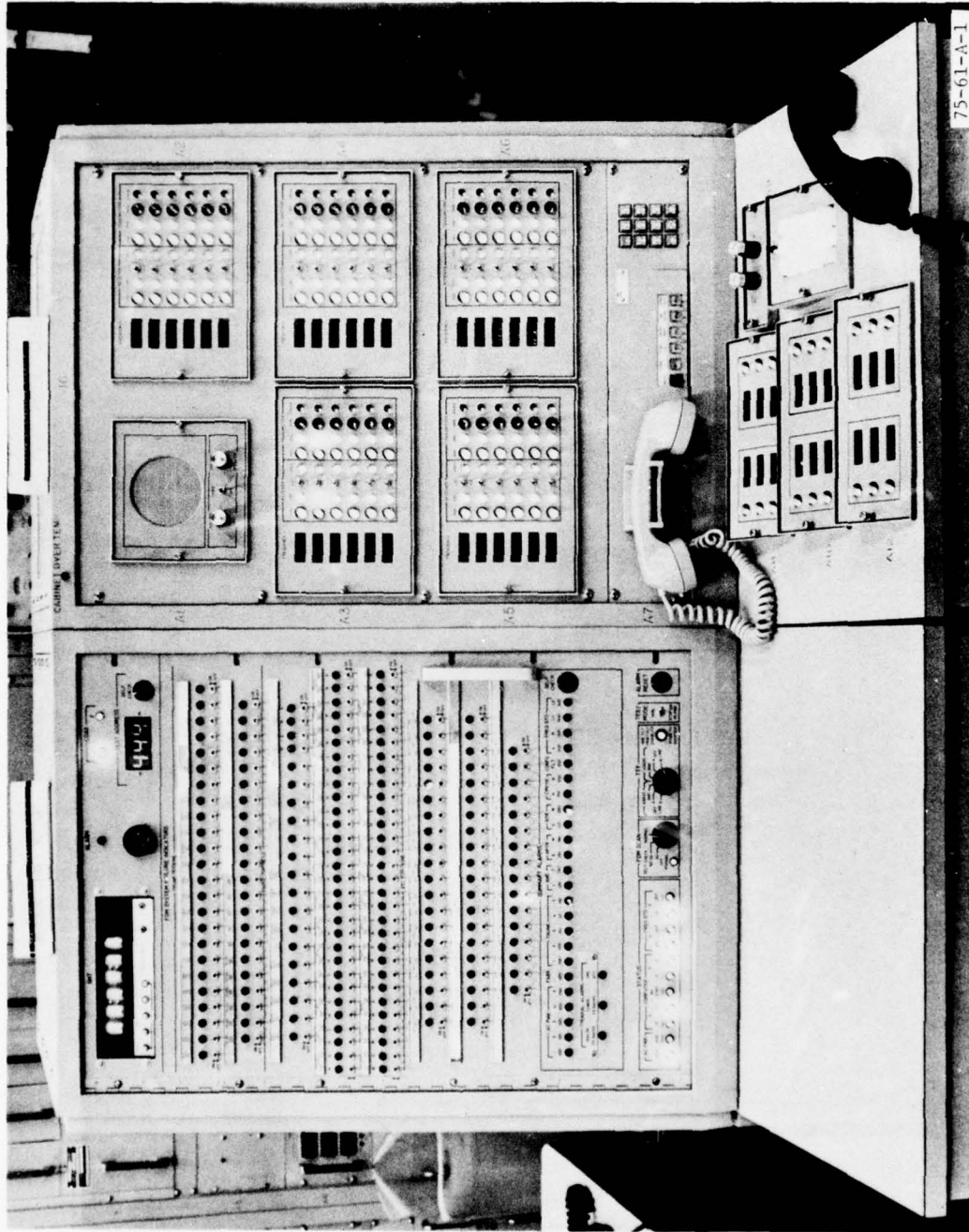

FIGURE A-1. TCSS SYSTEM MAINTENANCE CONSOLE

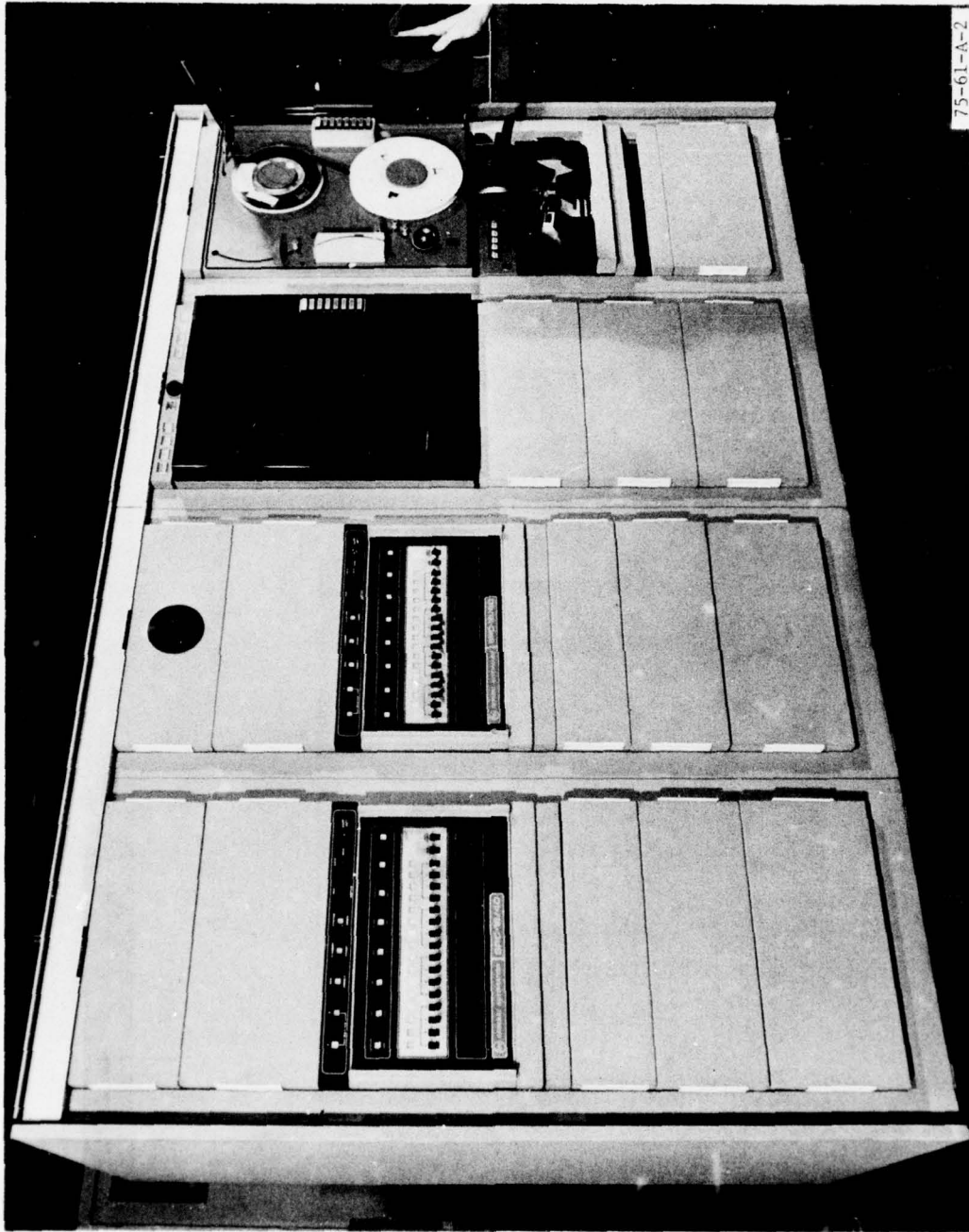

FIGURE A-2. TCSS RECONFIGURATION AND MONITOR ELEMENT

TRANSMISSION.

All voice, signalling, and data within TCSS is modulated (single-sideband AM) and then multiplexed (frequency division multiplexing) for transmission on redundant coaxial cable. This technique provides high-quality transmission, isolated from the surrounding environment and, because signalling and data are included in the cable transmission, the physical system control interface connections are minimized. FDM multiplexing of signalling and data also reduces the data transmission error rate and the complexity of control circuitry by permitting parallel transmission on all channels, thereby permitting a low data transmission rate (600 baud). Each combined voice/signalling/data channel provided by the FDM multiplexing is a full-duplex channel, providing four-wire equivalent transmission capability.

All signalling and data transmissions are encoded by the distributed control at each position and trunk to provide error detection capability. Whenever a transmission error is detected at a receiving unit, a retransmit request is returned to the transmitting unit, which automatically reattempts the transmission. It is therefore possible to successfully establish communications connections in the presence of transient error conditions.

MAINTENANCE PHILOSOPHY.

The TCSS maintenance philosophy consists of identification and replacement of failed major units online, followed by offline isolation and replacement of the failed card/module within the unit. The online and offline maintenance equipment is described below:

ONLINE MAINTENANCE EQUIPMENT.

System Maintenance Console (SMC). The SMC, consisting of the RTQC, the MCP, and a teletype printout unit is the main online maintenance equipment grouping.

Order Wire. The order wire provides communications between the SMC and each (East or West) RTR site.

Testboard. The testboard provided at the TELCO trunk interface equipment to permit connection to either line side or drop side circuits. This permits maintenance personnel to make busy tests, to establish an out-of-service condition for any line under test, and to originate or monitor calls.

Offline Maintenance Equipment. An offline maintenance facility is provided to simulate system interconnections to each major unit of the system, thereby permitting troubleshooting and isolation of faults within the unit to the card/module level, for replacement. The offline maintenance equipment consists of:

a. A test console houses special test circuitry and interconnection cabling which provides power, audio, radiofrequency, and digital data inputs to the unit under test; provides display and conversion circuits to interface

the unit output for display, recording, and teletype printout; provides operator controls to establish data formats and circuit selection for the unit under test; and provides terminals to interface input and output parameters with external generators, oscilloscopes, meters, and other standard test equipment.

- b. Maintenance Bench - Workspace
 - Storage
 - Test Equipment Bench

TCSS ELEMENTS.

The equipment complement which makes up the TCSS system is summarized below:

ATC Positions	38
Junction Modules	13
Power Racks	9
RTR Modem Racks	4
Trunk Modem Racks	3
RME Modem Racks	2
TELCO Interface Racks	2
RME	1
SMC	1
Coaxial Cable System	1
PABX	1
UPS	1

APPENDIX B

TCSS OPERATIONAL EVALUATION TEST DIRECTOR SCRIPT

TEST DIRECTOR SCRIPT FOR TCSS

1. Briefing

Brief controllers on purpose and methods of test.

a. Purpose

The purpose of the test is to evaluate the operational performance of the TCSS to verify that it meets the controllers needs, and to examine the TCSS as a candidate common system element for future procurements.

b. Pre-Run Exercise

Each controller will be requested to exercise TCSS controls and functions prior to the Test Run. (See attached Script)

c. Test Run

The duration of the test run will be approximately one hour. The controller will be requested to operate an *assigned control* position in the TRACON or Tower during which he will operate the TCSS in support of interphone/intercom and radio requirements. Radar targets will be displayed on the ARTS III display to stimulate communications.

d. Questionnaires

After the Pre-Run Exercise and the Test Run, controllers will be requested to complete a questionnaire on the TCSS. The questions mainly concern operational reliability, equipment design, system features and equipment placement. The responses received will be used in determining modifications and the design of future systems.

INTERCOM/INTERPHONE POSITION STARTUP

1. Plugging headset or handset into OPERATOR jack on the Jack Panel enables all position pushbutton controls.
2. Turn the LAMP BRT and LED BRT control knobs (on the Dimmer Panel) fully clockwise.
3. Check that all indicators (individual lamps and lighted pushbuttons) and LED displays are illuminated.
4. Adjust the LAMP BRT and LED BRT to the desired intensity.
5. Check that all LED displays contain reasonable information.
6. Turn the VOLUME HDST and VOLUME SPEAKER control knobs (on the Speaker Panel) fully counter-clockwise (lowest volume setting).
7. Depress the IA pushbutton (on the Dialer), then gradually turn the VOLUME HDST control knob clockwise and listen for DIAL TONE in the headset or handset.
8. With DIAL TONE in the headset, unplug the headset from the Jack Panel. Gradually turn the VOLUME SPEAKER control knob clockwise until DIAL TONE is heard from the loudspeaker.
9. Plug in the headset again. DIAL TONE will transfer from the speaker to the headset. Depress the IA pushbutton to turn off DIAL TONE.
10. Dial IA -6 (depress IA pushbutton, listen for DIAL TONE, then depress the Dialer pushbutton numbered "6"). This action initiates a position electronics self-test cycle (approximately one second duration). If the test detects no failures, the IA pushbutton, which starts to blink when first depressed, will stop blinking. No audible tones will be heard unless a malfunction has been detected.
11. Dial IA -0 followed by the Directory Number of this position. This action initiates an interface channel test. If no failure is detected, a combination of DIAL TONE and BUSY TONE will be heard. Depress the IA pushbutton to turn off the tone.
12. Set CHIME switch (on Speaker Panel) to the up position.

RADIO OPERATION STARTUP

Receiver Selection

1. Place at least one receiver into headset by putting the three position toggle switch in the DOWN position.
2. Place at least one receiver into loudspeaker by putting the three position toggle switch in the UP position.

Transmitter Selection

1. Depress at least one XMTR pushbutton, which changes its (green) light status from OFF to STEADY.
2. Operate the push-to-talk (PTT) to transmit. If the associated red Transmit Status Indicator light (labelled STATUS, and located to the right of the XMTR pushbutton) indicates STEADY the selected transmitter is in use and this position cannot transmit on that channel. The red STATUS indicator will FLUTTER when the PTT at this position is operated, and the position can transmit.

NOTE: Whenever the green XMTR and the red STATUS indicators are both STEADY for a given channel, BUSY TONE will be heard so long as PTT is operated.

3. Release the PTT when transmission is over. The XMTR (green) status light remains STEADY, and the STATUS indicator will change from FLUTTER to either OFF or, if that particular radio channel is accessed by another position, to STEADY.

Receiver Main/Standby Selection

1. Locate the LED display which contains the desired radio channel frequency (extreme left end of Radio Panel).
2. Locate the green XMTR pushbutton (second from right) under the TRANSMITTER heading. If the XMTR light status is OFF, depress that pushbutton to enable access to the channel. The XMTR light status will change from OFF to STEADY.

NOTE: Main/Standby selection will not function unless XMTR status is STEADY.

3. Locate the MAIN (left-most) pushbutton under the RECEIVE heading. The MAIN pushbutton indicator light status, and the STBY indicator light status will be in opposite states - one OFF and the other STEADY (both indicator lamps are white). The current MAIN/STANDBY selection status is shown by the indicator (MAIN or STBY) with the STEADY status.
4. Depress the MAIN pushbutton. The light status of the MAIN or STBY indicators will reverse.
5. Depress the MAIN pushbutton whenever it is desired to change MAIN/STANDBY selection.

Transmitter Main/Standby Selection

The Transmitter Main/Standby Selection process and status indication is identical to, though independent of, the Receiver Main/Standby Selection, described above. The transmitter MAIN pushbutton/indicator and STBY indicator are located under the TRANSMITTER heading on the Radio Panel.

Radio Initialization

Following reconfiguration, it is necessary to initialize the radio channels prior to use. After a reconfiguration, all MAIN (pushbutton/indicator) status indicators will be STEADY, and all STBY (indicator only) and XMTR (pushbutton/indicator) status indicators will be OFF. To initialize a given radio channel:

1. Depress the XMTR pushbutton. The green indicator will change status from OFF to STEADY.
2. Depress the transmitter MAIN pushbutton. The white indicator remains OFF, but the associated transmitter modem will be switched to MAIN (assuming the selected channel has a functional Main Modem).
3. Operate PTT. The red STATUS indicator will change from OFF to FLUTTER if both the Main modem and transmitter are present and operational.
4. Depress the transmitter MAIN pushbutton again. If the standby modem is present and operational, the transmitter MAIN status changes from STEADY to OFF, and the transmitter STBY status changes from OFF to STEADY. (Proceed to Step 5) If there is no standby radio, or if there is a non-functional standby modem, the transmitter MAIN status remains STEADY and the transmitter STBY status remains OFF.

5. Operate PTT. The red STATUS indicator will change from OFF to FLUTTER only if there is an operational Standby Transmitter.
6. Depress the transmitter MAIN pushbutton a third time. The transmitter MAIN status will change from OFF to STEADY and the transmitter STBY status will change from STEADY to OFF only if there is a functional Main Modem.
7. Repeat Steps 2, 4 and 6 for the corresponding Receiver MAIN pushbutton/Indicator and Receiver STBY indicator (PTT functions do not affect Receiver operation).

Simultaneous Radio/Intercom/Interphone Communications

Whenever there is at least one radio transmitter selected, and the PTT is operated, outgoing voice from the position is simultaneously transmitted over all selected radio, intercom and interphone circuits. Received intercom/interphone voice, however, will never be transmitted on the radio circuits.

Special Function

Call Forward

Forwards all Intercom/Interphone calls (except Voice Calls) from this position to any other position within the facility. Dial IA-3, followed by the three-digit Directory Number of the position to which calls are to be forwarded. All call status indicators (DA, IA and CA pushbuttons, and the Override Indicator) will change to OFF, except for those associated with any call(s) in progress.

Once the Call Forward is initiated, no new calls can be placed or answered at the position.

Call Forwarding can be cancelled only by the initiating (forwarding) position.

NOTE: Calls forwarded prior to cancellation will neither revert to nor be affected by forwarding position.

APPENDIX C

COLLATED AIR TRAFFIC CONTROLLER QUESTIONNAIRE FOR THE
EVALUATION OF THE TCSS AT THE DALLAS/FORT WORTH
TOWER/TRACON

Air traffic controller questionnaire for the evaluation of the Terminal Communications Switching System at the Dallas/Fort Worth Tower/TRACON.

The asterisks (*) correlate appropriate comments to responses. All numbers shown in parenthesis reflect the number of test subjects that made the response.

All test subjects were air traffic control specialists from the Dallas/Fort Worth Tower/TRACON.

Name _____ Date _____ Position _____

OPERATIONS

1. Do you find the overall voice quality of the interphone/intercom circuits:

Excellent (25) Very Good (40) Good (12) Fair (1) Poor (0)

2. Do you find the overall voice quality of the radio circuits:

Excellent (27) Very Good (36) Good (10) Fair (1) Poor (0)

3. Are you able to adequately maintain the audio levels in the headset?

Yes (73) No (3)*

Comment: *(2)Radio louder than intercom

4. Are you able to adequately maintain the audio level in the speaker?

Yes (73) No (3)*

Comment: *(2)Could not balance radio and intercom

5. Are you aware of any background noise on an interphone or intercom call?

Yes (26) No (52)

6. If your answer to Question 5 was yes, was the background noise a deterrent to good working conditions?

Yes (15) No (20)

7. In your opinion, are there sufficient radio and interphone/intercom modules (keys) at the position?

Yes (68) No (8) Too Many (1) Too Few (8)

8. Do you prefer having a common release button to terminate all types of calls instead of redepessing the same button used initially?

Yes (46) No (32)

9. Do you find using the IA panel as an optional method of communications when the DA panel malfunctioned acceptable?

Yes (68) No (7)

10. Do you find the TCSS too complex to operate?

Yes (1) No (77)

11. Do you have any difficulty in operating the TCSS?

Yes (12)* No (65)

Comment: *(3) Figures hard to read on LED's
*(2) Lag in lights on all buttons
*(1) Buttons stuck
*(3) Buttons should be spring loaded

12. In your opinion, do you find the operation of the TCSS very different from other communications systems you have operated in the past?

Yes (30)* No (47)

Comment: *(4) More flexible than others
*(2) A better system
*(2) After operational use it will probably be easier

13. Are there any operating characteristics which caused irritation?

Yes (35)* No (42)

If Yes, comment: *(15) Person overriding cannot hear aircraft
*(4) Should be able to answer calls in queue after a call forward has been initiated
*(4) LED's difficult to read *(2) Buttons are sharp
*(4) Lag in lights after depressing

14. Did you consider the training required to learn to operate the TCSS:

Extensive, but not difficult (9)

Easily learned over short period (51)

Very similar to existing system, therefore transition very easy (14)

Very difficult to learn the operation (0)

15. Assuming that the system is operating without malfunction, do you feel the TCSS as compared to the systems you have operated in the past is:

 (23) a great improvement
 (42) a moderate improvement
 (6) about the same
 (4) not as good

16. In your opinion, does the TCSS meet the needs of the controller in this facility?

Yes (68) No (4)

Human Factor Considerations

On the next three questions, answer appropriate one.

17. Comment on the positioning of the TCSS panels in the Tower Cab.

Jack Panel	Satisfactory <u> (48) </u> Remarks	Unsatisfactory <u> (2) </u>
Dimmer Panel	Satisfactory <u> (46) </u> Remarks	Unsatisfactory <u> (4) </u>
Speaker Panel	Satisfactory <u> (49) </u> Remarks	Unsatisfactory <u> (1) </u>
Dialer Panel	Satisfactory <u> (46) </u> Remarks	Unsatisfactory <u> (4) </u>
Direct Access Panel	Satisfactory <u> (49) </u> Remarks	Unsatisfactory <u> (1) </u>
Radio Panel	Satisfactory <u> (48) </u> Remarks	Unsatisfactory <u> (2) </u>

18. Comment on the positioning of the TCSS panels at the vertical ARTS III displays in TRACON.

Jack Panel	Satisfactory <u> (60) </u> Remarks	Unsatisfactory <u> (0) </u>
Dimmer Panel	Satisfactory <u> (57) </u> Remarks	Unsatisfactory <u> (3) </u>
Speaker Panel	Satisfactory <u> (58) </u> Remarks	Unsatisfactory <u> (2) </u>
Dialer Panel	Satisfactory <u> (57) </u> Remarks	Unsatisfactory <u> (3) </u>
Direct Access Panel	Satisfactory <u> (58) </u> Remarks	Unsatisfactory <u> (2) </u>
Radio Panel	Satisfactory <u> (57) </u> Remarks	Unsatisfactory <u> (3) </u>

19. Comment on the positioning of the TCSS panels at the horizontal ARTS III displays in TRACON.

Jack Panel	Satisfactory <u> (55) </u> Remarks	Unsatisfactory <u> (1) </u>
Dimmer Panel	Satisfactory <u> (55) </u> Remarks	Unsatisfactory <u> (1) </u>
Speaker Panel	Satisfactory <u> (45) </u> Remarks	Unsatisfactory <u> (11) </u>
Dialer Panel	Satisfactory <u> (56) </u> Remarks	Unsatisfactory <u> (0) </u>
Direct Access Panel	Satisfactory <u> (55) </u> Remarks	Unsatisfactory <u> (1) </u>
Radio Panel	Satisfactory <u> (53) </u> Remarks	Unsatisfactory <u> (3) </u>

20. The readability of the Light Emitting Diode (LED) in the tower cab is:

Excellent (0) Very Good (7) Poor (21) Unreadable (30)

21. If your answer to Question No. 20 was either poor or unreadable, do you contribute this to:

Location of Module (1) Size of Characters (17) High Ambient

Light (46) Other (9)* Comment: *(8) Poor color
*(1) Cannot make them bright enough

22. The readability of the Light Emitting Diode (LED) in the TRACON is:

Excellent (15) Very Good (41) Poor (19) Unreadable (2)

23. If your answer to Question No. 22 was either poor or unreadable, do you contribute this to:

Location of Module (2) Size of Characters (16) Ambient Light

Level (8) Other (16)* Comment: *(10) Poor color
*(6) Some characters hard to read

24. Is the pressure necessary to activate the various pushbuttons:

About right (70) Takes too much pressure (7) Activates too
easily (0)

25. Are any components of the communications system located in a position or designed in a manner that might cause injury?

Yes (15)* No (60) Comment: *(7) Speaker on horizontal displays
*(2) Screws holding modules should be recessed

26. Rate the overall ease of operation of the TCSS compared with the old system.

a. Easier to operate (20)

b. About the same (40)

c. More difficult than present system (16)

27. Are the Headset Volume, Speaker Volume, Chime Volume and Chime On/Off controls satisfactory as to location and operating characteristics?

Yes (63) No (14)*, If no, comment:

Comment: *(9) Chime volume control location poor
*(3) Location on horizontals too high

28. Are the LED BRT and Lamp BRT controls satisfactory as to location and operating range?

Yes (71) No (7)*, If no, comment:

Comment: *(5) Operating range in tower poor

29. Are the buttons on the "Direct Access Panel" spaced

About right (73) Too close (0) Too far apart (5)

30. Are the buttons and the switches on the "Radio Panel" spaced

About right (76) Too close (2) Too far apart (0)

31. Rate by number (1 thru 5) those functions of the TCSS that you find most effective, number 1 being the higher score.

<u>Function</u>	<u>Comment</u>
Direct Access _____	1(48), 2(10), 3(9), 4(3), 5(3)
Call Forward _____	1(36), 2(13), 3(7), 4(4), 5(4) 7(1)
Reconfiguration _____	1(22), 2(10), 3(6), 4(5), 5(5), 6(1)
Common Answering Calls in Queue _____	1(18), 2(15), 3(14), 4(3), 5(5), 6(1), 7(1)
Direct Access Voice Call _____	1(18), 2(22), 3(12), 4(6), 6(2)
Indirect Access _____	1(15), 2(17), 3(24), 4(9), 5(6), 6(1), 7(2)
Direct Access Override _____	1(34), 2(23), 3(4), 4(1), 5(6)

32. Rate by number (1 thru 5) those features of the TCSS that you find most desirable, number 1 being the higher score:

<u>Feature</u>	<u>Comments</u>
Key Design (Interphone) _____	1(34), 2(11), 3(12), 4(5), 5(6)
Key Design (Radio) _____	1(29), 2(10), 3(17), 4(8), 5(3)
Panel Design (Interphone) _____	1(29), 2(18), 3(11), 4(3), 5(5), 6(1)
Panel Design (Radio) _____	1(30), 2(15), 3(12), 4(7), 5(3), 6(1), 7(1)
Color Coding _____	1(17), 2(7), 3(23), 4(8), 5(5), 9(2)
Labeling _____	1(12), 2(17), 3(12), 4(10), 5(13), 8(2)
Illumination _____	1(22), 2(15), 3(12), 4(5), 5(13), 7(1)
Voice Quality (Interphone) _____	1(45), 2(21), 3(3), 4(4), 5(2)
Voice Quality (Radio) _____	1(50), 2(15), 3(2), 4(4)

Expansion Features

33. There are 18 Direct Access (DA) keys for each operating position, considering maximum load conditions and future expansion, do you think this number:

Sufficient (65) Too Few (12) Too Many (0)

34. Assuming air traffic activity will increase over the next ten years at the same rate it has in the past, do you believe the TCSS can accommodate this increase?

Yes (64) No (11)

35. If the answer to the above question was yes, do you believe the position equipments (panels, keys, physical layout) would require any major expansion and relocation.

Yes (14) No (13)

36. Does the TCSS have too many unnecessary features?

Yes (21) No (53)

Flexibility

37. Do you find the "Call Forward" function an effective and efficient way to transfer position calls? Or combining positions?

Yes (72) No (6)*

Comment: *(2) Cannot forward voice calls

38. What is your opinion on the "Reconfiguration" technique of the TCSS.

Provides maximum flexibility combining sectors (66)

Not needed - enough flexibility on position assignments (0)

39. Based on your experience with the communication system that was in use at the previous TRACON, do you believe the TCSS provides sufficient flexibility?

Yes (76) No (0)

Reliability

40. While operating on position, have you encountered many system malfunctions?

Yes (18)* No (58)

If yes, list the malfunctions:

Comment: *(5) Radio inoperative

*(3) Buttons stuck

41. Check any of the units below that have had excessive malfunctions:

Keys	<u>(8)</u>
Panels	<u>(0)</u>
Jack Units	<u>(1)</u>
Lighting	<u>(2)</u>
Note Any Other	<u> </u>

42. Do you find it necessary to depress any of the keys more than once in order to activate them?

Yes (31) No (47)

43. Is button sticking a problem?

Yes (6) No (72)

In the space below, please comment on any subject that you feel has not been covered by the above questions.

- (4) Returning from Call Forward, radio stays in speaker*
 - (3) Voice calls and calls in queue cannot be forwarded
 - (7) Buttons easily broken, should be shorter
 - (3) Buttons should be spring loaded
 - (15) Overrider cannot hear aircraft talking to person overridden
 - (2) Need more direct access lines
 - (4) Lag in all lights
 - (2) Change override code to "0" and intercom code to "1"
 - (2) Clear **All Calls** only clears **override** calls
 - (2) Should be able to answer remaining calls after call forward initiated
 - (2) Module hold down screws should be recessed
 - (16) Can only realistically evaluate under operating conditions
 - (7) LED's would be easier to read if larger and of different color
- *Note: Radio no longer stays in speaker upon returning from Call Forward

APPENDIX D

MICROPROCESSOR STRUCTURE AND PROGRAMMER SKILLS

STRUCTURE OF THE PE MICROPROCESSOR.

HARDWARE. The structure of the microprocessor is as shown in figure D-1. The central processing unit is the INTEL 8008 chip, which implements 48 instructions and has an instruction cycle time of 20 microseconds (μ s). This chip is surrounded by memory, input/output logic, and timing generator.

PROGRAMMING. The microprocessor reacts to various inputs as shown in the flow chart (figure D-2). The microprocessor, under control of its program, continually tests to see if there are inputs. Each time an input is found, it is examined and appropriate action is taken. The sequence for testing for inputs is such that an input from the junction module, a push-to-talk (PTT) command, and an input from either a direct access (DA) or indirect access (IA) module, the home receiver, the calling receiver, or the reconfigure and monitoring element (RME) receiver can be executed each processing cycle. This assures that a radio input command and one other command can be serviced with the system being ready for the next input within 10 ms.

FUNCTIONS. The microprocessor has two basic functions. The first is to accept the reconfiguration and the second is to react to commands associated with the voice communication function.

During reconfiguration there is a stream of bytes flowing into the microprocessor through the RME receiver. These are stored in random access memory.

After receipt of the entire reconfiguration message, those bytes involved in configuring the junction module are relayed to that unit. Also light emitting diode (LED) display information is relayed to the DA and radio modules. The entire reconfiguration requires several seconds, during which time all pushbutton inputs are disabled. Thus the position microprocessor is occupied only with accepting and storing information from the RME, checking it for accuracy, making the appropriate responses, and relaying appropriate information to the associated junction modules, DA modules, and radio modules.

After reconfiguration, the microprocessor continuously scans all of its inputs. Each time an input is found from the pushbutton encoder, a table lookup is made to interpret its meaning, and a two byte indication is sent to the RME traffic data collection function, via the RME transmitter. The interpretation of the pushbutton may be to tune the calling TRS to a specific frequency and transmit control bytes, thereby placing a call to store the information and wait for additional pushbutton depressions, or it may be to modify some logical function such as headset to loudspeaker transfer. Inputs from the calling TRS are responses to attempts to place calls and are so interpreted. Inputs from the home TRS represent incoming calls which must be interpreted in terms of the busy/idle status of the position, and an appropriate response is generated. Inputs from the RME TRS indicate the arrival of a new reconfiguration or an RTQC test interrogation.

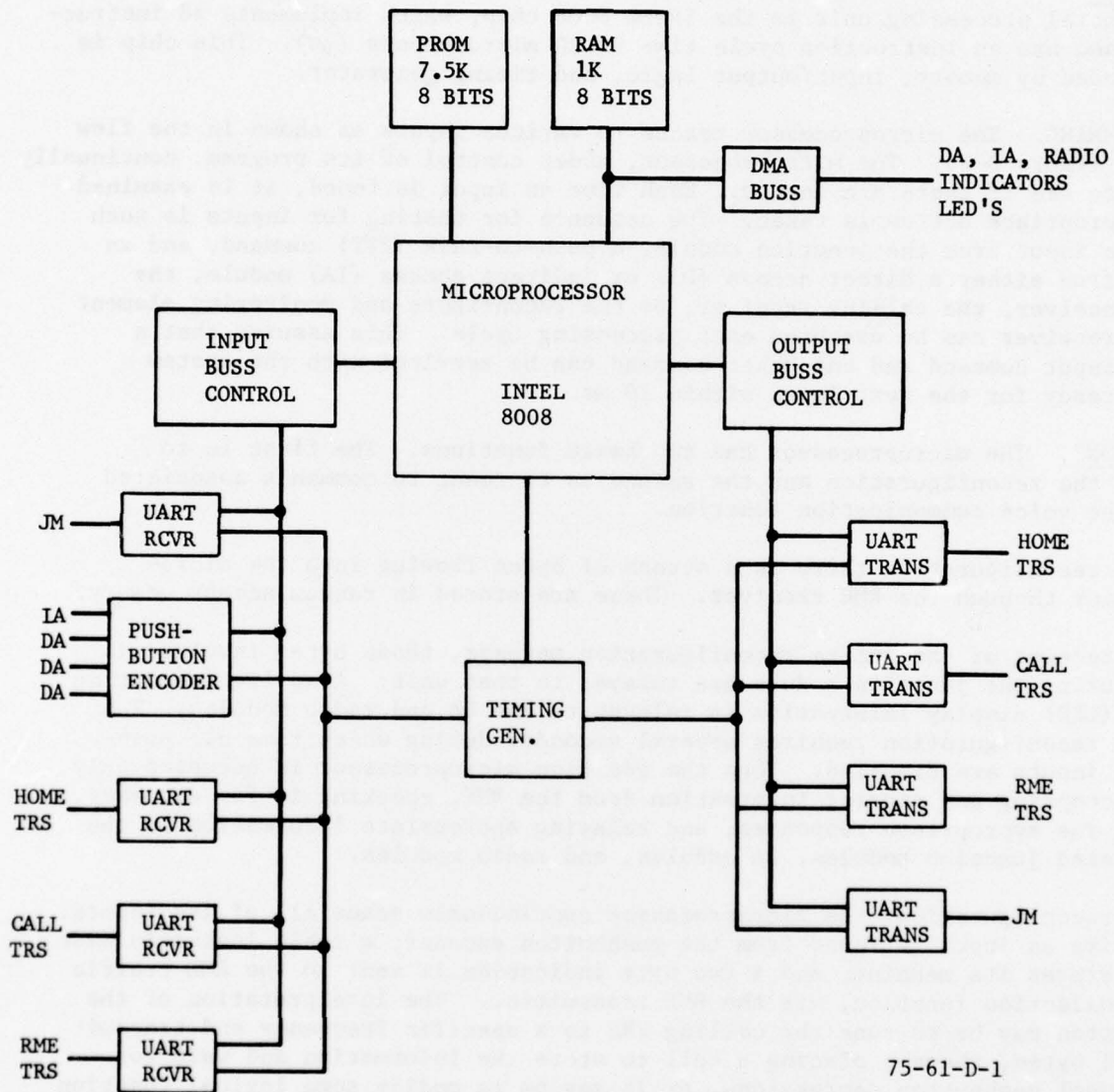
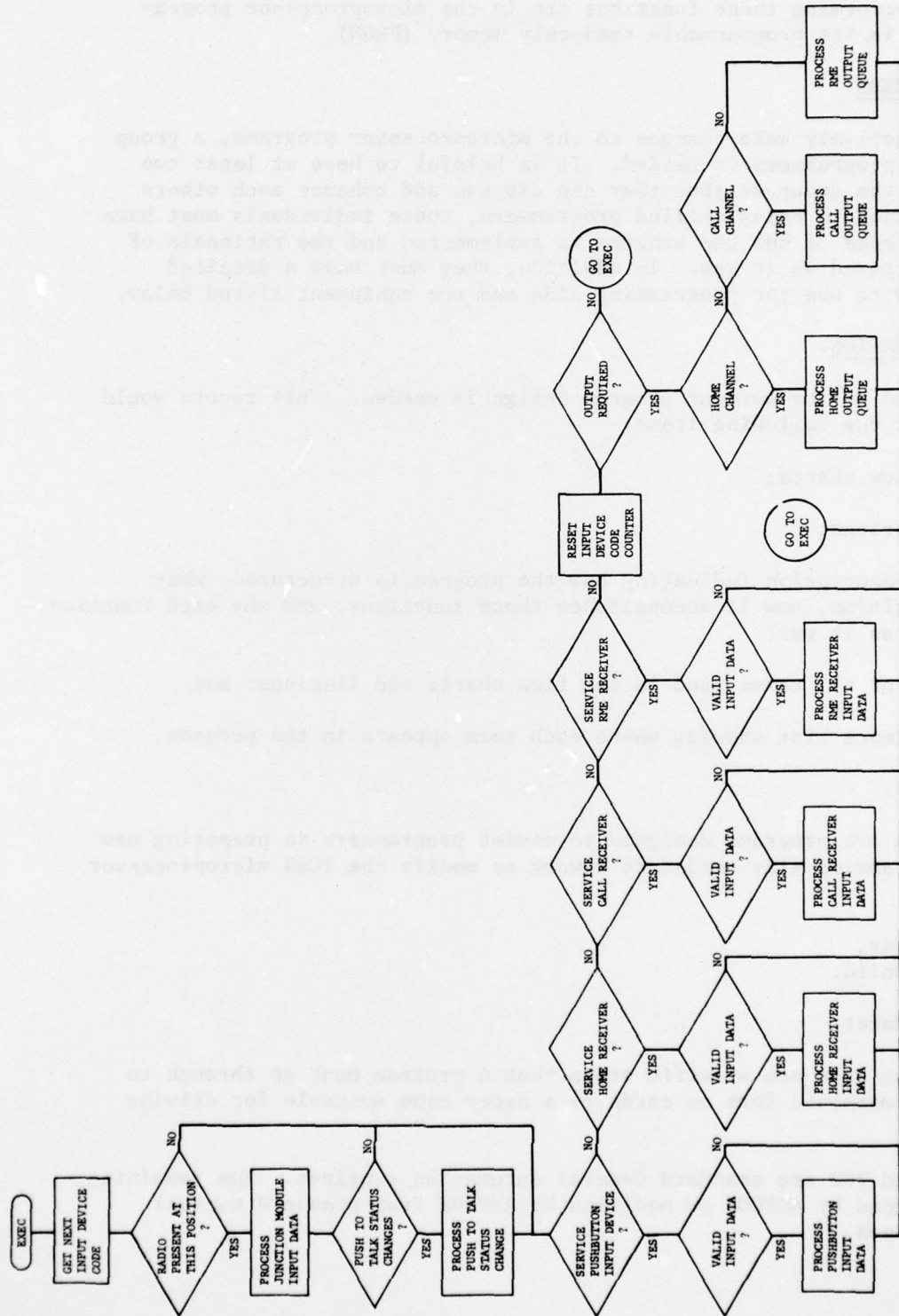

FIGURE D-1. MICROPROCESSOR HARDWARE STRUCTURE



75-61-D-2

FIGURE D-2. TCSS EXECUTIVE ROUTINE

The steps for performing these functions are in the microprocessor program which is stored in its programmable read-only memory (PROM).

TRAINED PROGRAMMERS.

In order to effectively make changes to the microprocessor programs, a group of well trained programmers is needed. It is helpful to have at least two such persons in the group so that they can discuss and enhance each others ideas. In addition to being skilled programmers, these individuals must have a detailed knowledge of how the program is implemented and the rationale of why it was structured as it was. In addition, they must have a detailed knowledge of how to use the programming aids and the equipment listed below.

PROGRAM DOCUMENTATION.

A complete record of the current program design is needed. This record would include at least the following items:

1. Detailed flow charts;
2. Program listings;
3. Narrative description indicating how the program is structured, what functions it performs, how it accomplishes those functions, and why each function was implemented as it was;
4. Definition of all terms used in the flow charts and listings; and
5. Cross reference list showing where each term appears in the program.

PROGRAMMING AIDS.

Programming aids are programs designed to assist programmers in preparing new programs. Programming aids needed to rework or modify the TCSS microprocessor programs are:

1. Raw assembler,
2. Core Load Build,
3. P Load, and
4. PROM Tape Maker.

These programming aids are specific steps that a program must go through to convert it from mnemonic form on cards to a paper tape suitable for driving the PROM burner.

The assembler and PGS are standard General Automation routines. The remaining items were produced by AMECOM or modified by AMECOM from standard General Automation routines.

KEY PUNCH.

A standard key punch is needed to prepare card decks of the mnemonic coded instructions.

GENERAL AUTOMATION PROCESSOR.

A General Automation 1600 processor is needed to execute the assembler and other conversion routines. This machine must be equipped with:

1. Memory,
2. Card Reader/Punch,
3. Disc,
4. Magnetic Tape,
5. High-Speed Printer, and
6. Paper Tape Reader/Punch.

The two General Automation processors used in the TCSS RME functions are each capable of performing the required functions if equipped with additional core memory, high-speed printer, and high-speed paper tape punch.

If there are any plans to use the offline RME processor for programming support or any other non-RME functions, care must be taken to assure that this work does not endanger the TCSS operation. Global reconfiguration should never be attempted unless both RME processors are serving their RME role. A malfunction of the online processor during reconfiguration normally causes an automatic transfer of the offline processor, which then performs the reconfiguration. If the offline processor is occupied with some other function, the TCSS could be left completely inoperable for up to 1/2 hour, until manual attention places one of the machines online so that the reconfiguration can be restarted.

PROM ERASER.

The PROM units used in the system are capable of being erased by exposing them to high-intensity ultraviolet light, so that they can be rewritten. A special chamber with a light source in it is available to perform this function. This equipment is needed to allow reuse of the PROM units.

PROM BURNER/COPIER.

The PROM burner is a logic configuration which writes information into a PROM byte. Normally the PROM burner, equipped with a high-speed paper-tape reader is used to copy the computer output (paper tape) into a set of PROM units. This first set is completely checked in an operational position. When the programmer is confident that the revised program is fully operational, the first set of PROM units may be copied onto other PROM units using the same PROM burner. The copying process is relatively fast compared to the process of producing the first units from paper tape.

CHECK SUM GENERATOR.

As the position microprocessor operates, it continually generates "check sums" which are compared with check sums stored in the PROM. This provides assurance that the PROM units are being read error free. A logic configuration for generating these check sums was assembled by AMECOM for use in producing the original programs. Since any change to the program will change the check sums stored, a check sum generator will be required to work with the PROM burner in producing the initial PROM units.

MANUAL CONTROL UNIT.

The manual control unit (MCU) consists of a logic configuration that can be attached to a standard position electronics with a series of cable adapters that are inserted between some of the plug-in cards and the back plane sockets. The MCU provides the functions of a computer console, allowing the program to be halted and the contents of critical registers examined and modified.

An MCU will be required to give the programmers the ability to debug any changes to the existing programs and any new programs they might develop for the position microprocessor.

GLOSSARY

AC	Arrival Coordinator
AF	Airways Facilities
AGC	Automatic Gain Control
AR	Arrival
ASR	Automatic Send Receive Teletype
ATC	Air Traffic Control
ATIS	Automatic Terminal Information Service
CAR	Carswell
CCE	Cab Coordinator East
CCW	Cab Coordinator West
CDE	Clearance Delivery East
CDW	Clearance Delivery West
DA	Direct Access
DBOS	Disk-Based Operating System
DC	Departure Coordinator
DMA	Direct Memory Access
DN	Dallas North
DR	Departure
DS	Dallas South
FD	Flight Data
FDE	Flight Data East
FDM	Frequency Division Multiplexing
FDW	Flight Data West
FE	Feeder East
FME	Flight Monitor East
FMW	Flight Monitor West
FTS	Federal Telecommunications System
FW	Feeder West
GA	General Automation
GCE	Ground Control East
GCW	Ground Control West
HO	Handoff
IA	Indirect Access
JM	Junction Module
LCE	Local Control East
LCW	Local Control West
LVR	Line Voltage Regulator
MEA	Meacham
MCP	Maintenance Communications Position
MCU	Manual Control Unit
MHz	Megahertz
MUX	Multiplexer
PABX	Private Automatic Branch Exchange
PE	Position Electronics
PGS	Program Generation System
PROM	Programmable Read Only Memory
RAM	Random Access Memory
RME	Reconfiguration Monitor Element
RTQC	Real Time Quality Control

RTR	Remote Transmitter Receiver
SFA	Single Frequency Approach
SMC	System Maintenance Console
TCSS	Terminal Communications Switching System
TDC	Traffic Data Collection
TRACON	Terminal Radar Approach Control
TRS	Transmit Receive Synthesizer
UART	Universal Asynchronous Receive/Transmit
UPS	Uninterruptable Power Source
VOX	Voice-Operated Switch