

AD-A040 871

MCDONNELL DOUGLAS ASTRONAUTICS CO TITUSVILLE FLA
ENVIRONMENTAL TESTING OF A FLUIDIC DIGITAL-TO-ANALOG CONVERTOR.--ETC(U)

F/6 9/5

JUL 76 G W ROE

DAAG39-74-C-0212

UNCLASSIFIED

MDC-L0356-VOL-1

HDL-CR-76-212-1-VOL-1

NL

1 OF 2
AD A040871

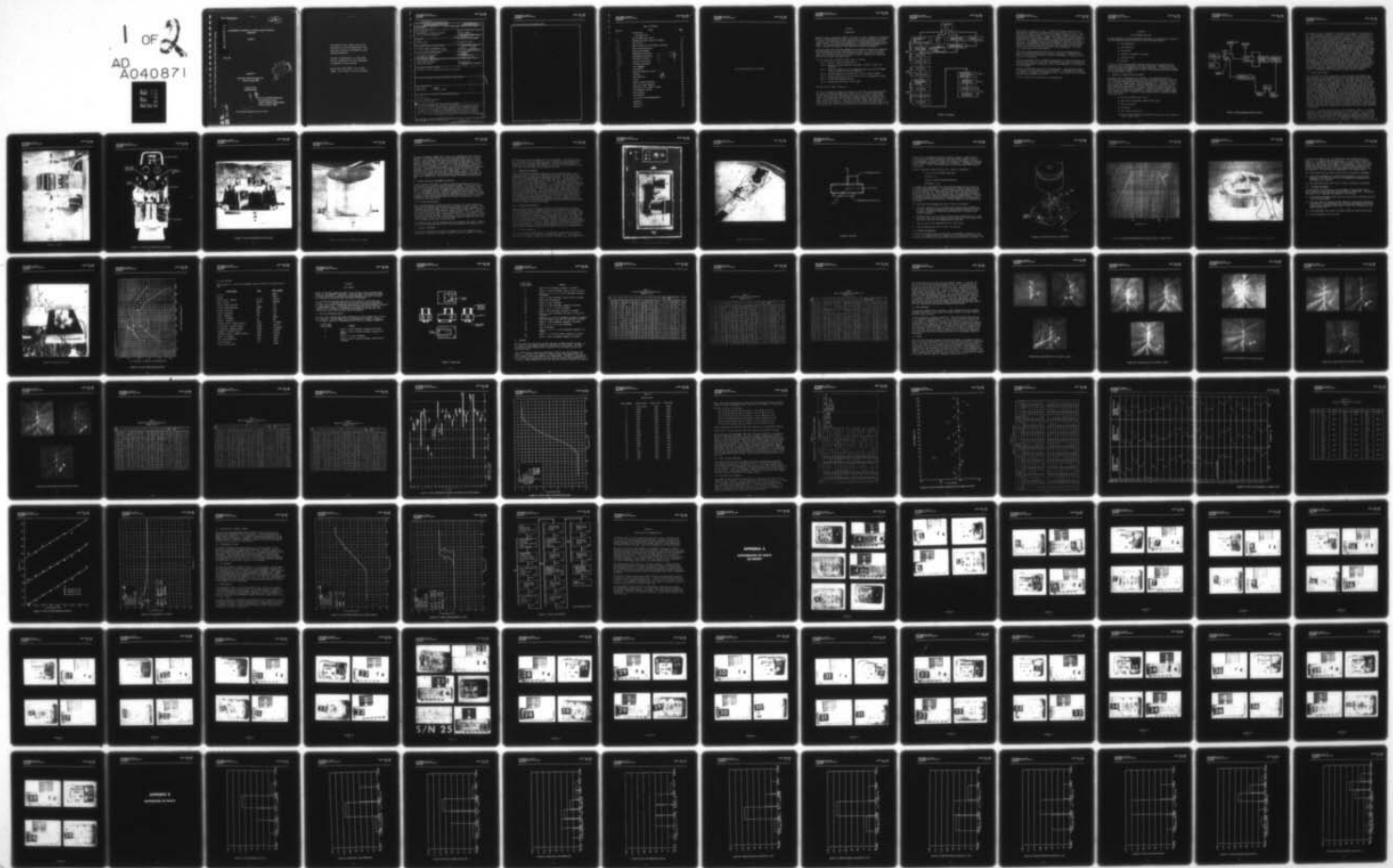

0408

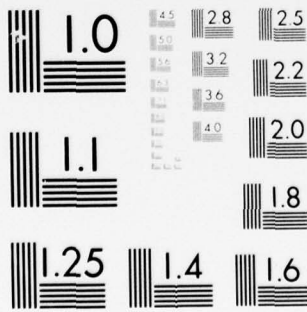

MICROCOPY RESOLUTION TEST CHART
NATIONAL BUREAU OF STANDARDS-1963-A

HDL-CR-76-212-1

12
NW

ADA 040871

ENVIRONMENTAL TESTING OF A FLUIDIC DIGITAL-TO-ANALOG
CONVERTER

VOLUME I

JULY 1976

CR-76-212-1, Environmental Testing of a Fluidic Digital-to-Analog Converter, Volume I, by George W. Roe

DDC
JUN 23 1977
C

Prepared by

McDonnell Douglas Astronautics Co.
Titusville, Florida 32780

Under Contract
DAAG39-76-C-0212

U.S. Army Material Development
and Readiness Command
HARRY DIAMOND LABORATORIES
Adelphi, Maryland 20783

AD No. _____
DDC FILE COPY

APPROVED FOR PUBLIC RELEASE; DISTRIBUTION UNLIMITED

The findings of this report are not to be construed as an official Department of the Army position unless so designated by other authorized documents.

Citation of manufacturers' or trade names does not constitute an official endorsement or approval of the use thereof.

Destroy this report when it is no longer needed. Do not return it to the originator.

UNCLASSIFIED

SECURITY CLASSIFICATION OF THIS PAGE (When Data Entered)

19. REPORT DOCUMENTATION PAGE		READ INSTRUCTIONS BEFORE COMPLETING FORM	
1. REPORT NUMBER HDL-CR-76-212-1 - Vol-2	2. GOVT ACCESSION NO.	3. RECIPIENT'S CATALOG NUMBER	
4. TITLE (and Subtitle) ENVIRONMENTAL TESTING OF A FLUIDIC DIGITAL-TO-ANALOG CONVERTOR. Volume I.		5. TYPE OF REPORT & PERIOD COVERED Final Report.	
7. AUTHOR(s) GEORGE W. ROE	14	6. PERFORMING ORG. REPORT NUMBER MDC-L0356 - Vol-1	
9. PERFORMING ORGANIZATION NAME AND ADDRESS McDonnell Douglas Astronautics Co. ✓ P. O. Box 600, Titusville, FL 32780		8. CONTRACT OR GRANT NUMBER(s) DAAG39-74-C-0212 new	
11. CONTROLLING OFFICE NAME AND ADDRESS Army Material Development and Readiness Command Alexandria, VA 22333		10. PROGRAM ELEMENT, PROJECT, TASK AREA & WORK UNIT NUMBERS Program: 62114A DA Project: 11T162114A644	
14. MONITORING AGENCY NAME & ADDRESS (if different from Controlling Office) Harry Diamond Laboratories 2800 Powder Mill Road Adelphi, MD 20783		12. REPORT DATE July 1976	
		13. NUMBER OF PAGES 224	
		15. SECURITY CLASS. (of this report) Unclassified	
		15a. DECLASSIFICATION/DOWNGRADING SCHEDULE	
16. DISTRIBUTION STATEMENT (of this Report) Approved for public release; distribution unlimited.			
17. DISTRIBUTION STATEMENT (of the abstract entered in Block 20, if different from Report)			
18. SUPPLEMENTARY NOTES HDL Project: 304434 DRCMS Code: 612114.11.71700			
19. KEY WORDS (Continue on reverse side if necessary and identify by block number) Fluidic Fluidic Fuzing Digital to Analog Convertor Environmental Testing			
20. ABSTRACT (Continue on reverse side if necessary and identify by block number) This report documents the results of a test program to investigate the performance of a fluidic subsystem when subjected to environmental extremes. Twenty-one fluidic digital to analog convertors were subjected to the environments of High Temperature, Low Temperature, Acceleration, Vibration, Acoustical Noise and Altitude, and their performance compared to baseline data. The results are presented, for each unit, in the form of histograms.			

D D C
APPROVED
JUN 23 1977
SECURITY C

405540

SECURITY CLASSIFICATION OF THIS PAGE(When Data Entered)

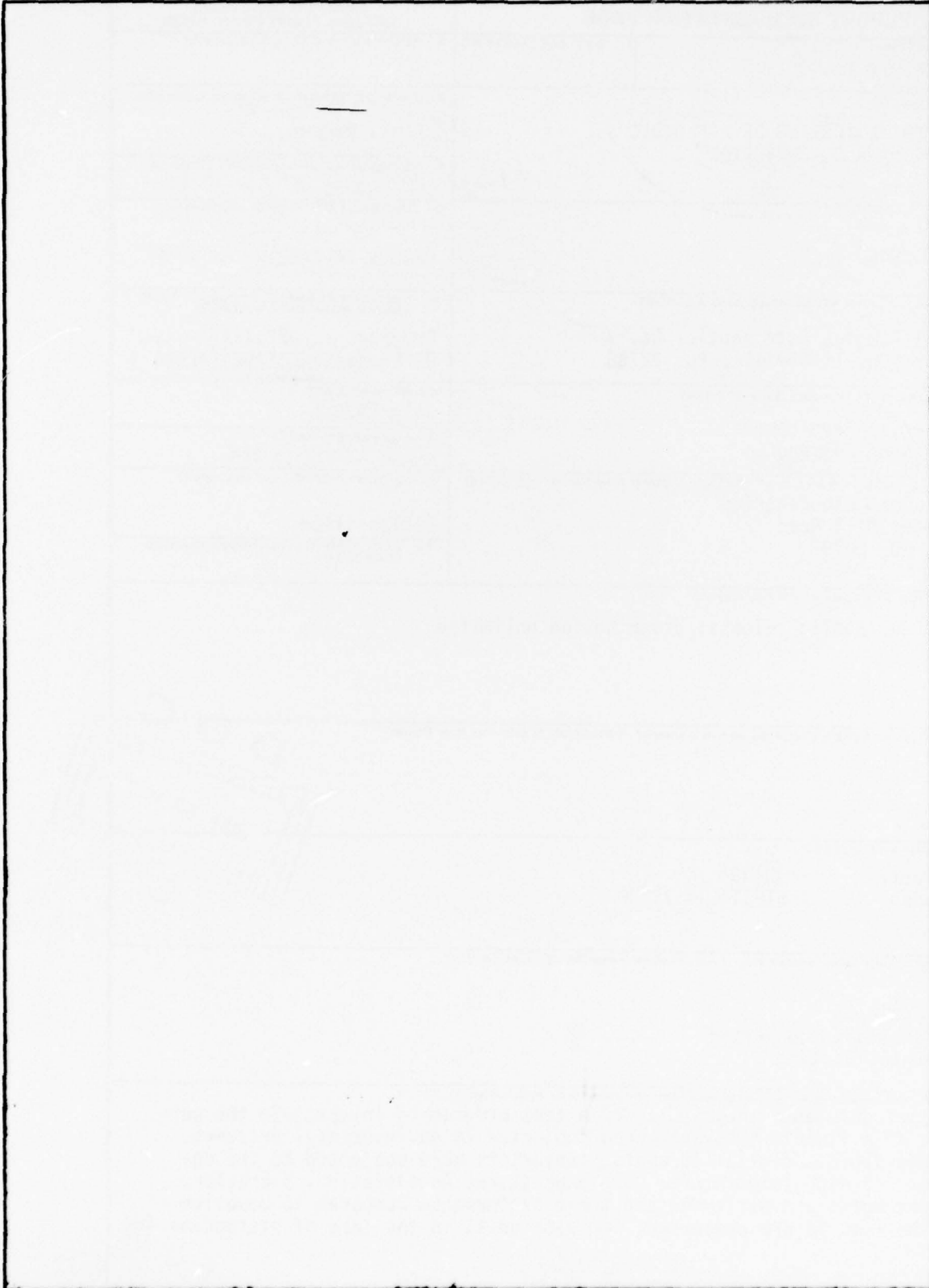

TABLE OF CONTENTS

<u>Section</u>	<u>Title</u>	<u>Page</u>
1	Introduction	5
	Task Definition	
2	Test Equipment and Set-Up	8
2.1	Portable Gas Power Supply and Chopper	8
2.2	FDAC Fixture	10
2.3	Ambient (Baseline) Environment Evaluation	15
2.4	Step Pulsing Evaluation	15
2.5	Adverse Environments	15
2.5.1	Temperature Evaluation	16
2.5.2	Acceleration Evaluation	16
2.5.3	Vibration Evaluation	16
2.5.4	Acoustical Evaluation	20
2.5.5	Altitude Environment	24
2.6	Test Equipment	27
3	Test Results	28
3.1	Received Condition of FDAC	28
3.2	Cleaning	30
3.3	Data Reduction	34
3.4	Tuning	34
3.5	Supply Pressure Variation	46
3.6	Step Pulse Input Response	46
3.7	Operation with a Schmitt Trigger	54
3.8	Environmental Testing	54
3.9	Test Sequence	54
3.10	Data Analysis	54
4	Conclusions and Recommendations	58
	Appendix A	59
	Appendix B	81
	Appendix C	102

ADDITIONAL INFO	
KTIS	Write Section <input checked="" type="checkbox"/>
DDC	Unit Section <input type="checkbox"/>
UNANTICIPATED JUSTIFICATION	<input type="checkbox"/>
BY _____	
DISTRIBUTION/AVAILABILITY CODES	
U.S.	AVAIL. STATE SPECIAL
A	

This page intentionally left blank.

SECTION 1

INTRODUCTION

McDonnell Douglas Astronautics (MDAC), Titusville, Florida, conducted an investigation for Harry Diamond Laboratories (HDL) and Picatinny Arsenal to determine the effects of specific environment on a fluidic subsystem of the type that might be part of a fuzing system. This particular subsystem is a fluidic digital-to-analog convertor (FDAC). The primary purpose of the program was to determine the performance of a fluidic subsystem when exposed to both ambient and adverse environments.

Twenty-one FDAC's were received by MDAC and their physical condition was documented by both photographs and prose descriptions (see section 3). Design and fabrication of the FDAC test fixtures, environmental chambers, signal source and power supply were completed before initial testing so that all testing was accomplished with the same fixtures and power supply.

The test program was conducted in seven tasks, as follows.

- Task A - Receive, clean and operate FDAC's.
- Task B - Ream the set point orifice of the FDAC's so that all units are identical.
- Task C - Install the FDAC's in an environmental chamber and ream the chamber orifice so that all units are identical.
- Task D - Perform compatibility testing with a fluidic Schmitt trigger
- Task E - Obtain baseline and step pulse data prior to environmental testing.
- Task F - Perform environmental testing.
- Task G - Analyze data and prepare final report.

The task flow is shown in Figure 1-1.

The initial ultrasonic cleaning and operation of the FDAC's were accomplished and all twenty-one units were operating; however, several of the units were erratic (noisy) and several other units would not operate continuously. Investigation of the erratic operation suggested that contamination was still present in the units. A backflush method of cleaning was adopted instead of the original ultrasonic method (see section 3). After the units were cleaned, the FDAC's were tuned so that they produced a differential output pressure of +5 psi at 400 ± 40 Hz; this frequency was chosen because the majority of the units were distributed in the

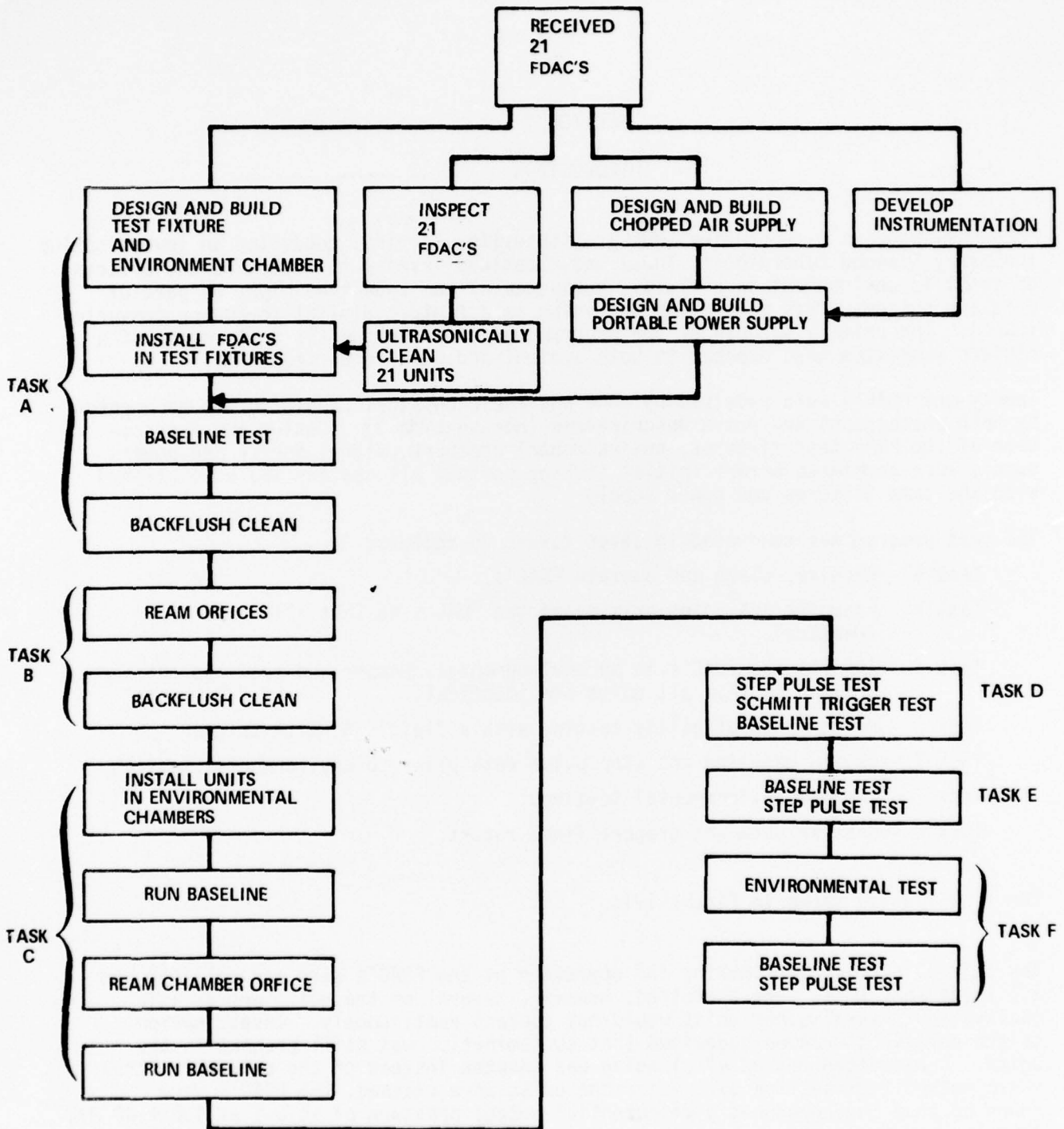

FIGURE 1-1 TASK FLOW

400 Hz area at an output of +5 psi. The FDAC's were then installed in the environmental chamber and the chambers were tuned to 500 Hz for +5 psi. This frequency was chosen by the orifice size and chamber pressure that would allow sonic flow across the orifice. Compatibility testing of the FDAC was accomplished using a fluidic Schmitt trigger. These tests were extremely successful, except that the response time of the entire system was relatively slow (see section 3). Environmental testing was initiated with a baseline run, then nineteen FDAC's were exposed to the desired environments. After each environment testing was completed, twenty-one units were again exposed to a baseline run. Serial number's 6 and 36 were never exposed to any environments. All other S/N's were exposed to all environments.

Data from all testing were plotted at the -5, 0 and +5 psi output pressure points to determine the frequency variation of the units with respect to each other and also with respect to the individual environments. These plots are in Volume II of the report.

Section 2 describes the test equipment, modifications to the test equipment and test techniques that were used. Each environmental test setup is discussed with relation to variations in parameters, limits of test equipment, and calibration of test equipment.

Section 3 contains the results of all the FDAC tests. Data tabulations within this section correlate test results by environment. In addition, data analysis is presented. Histograms are presented for the +5 test condition for the various baseline and environmental test runs.

Section 4 contains the conclusions and recommendations.

SECTION 2

TEST EQUIPMENT AND SETUP

The FDAC performance was evaluated under both ambient and environmental conditions. The environmental conditions to which the units were exposed were:

- High temperature
- Low temperature
- Acceleration
- Vibration, sinusoidal and random
- Acoustical noise
- Altitude

It will be noticed that the FDAC's were not exposed to any preconditioning environments, such as transportation, storage, or handling. Therefore, possible effects from these environments have not been determined. All functional evaluation utilized the test setup shown in Figure 2-1 with some modifications performed during environmental testing.

2.1 PORTABLE GAS POWER SUPPLY AND CHOPPER

During the initial investigation of the FDAC's, it was determined that the data which would be obtained should have as many variables minimized as possible; i.e., the data obtained from the FDAC should be only that of the FDAC and not of the X-Y recorder, chopped supply, pressure transducer, etc. Therefore, a single source power supply was chosen so that each FDAC would be identically excited. With standard test equipment (X-Y recorders, frequency to analog convertors, etc.) there is little problem if the equipment is correctly calibrated; however, the power supply and connections could present a severe problem if the supply changes or the connections leak. Therefore, it was decided to build a chopper and power supply that would:

- Be able to supply clean, dry air
- Have easily controllable chopped signal supply
- Be well regulated
- Be portable
- Have minimum connections
- Have equipment permanently mounted (to insure use of same regulators, filters, dryers, etc.)

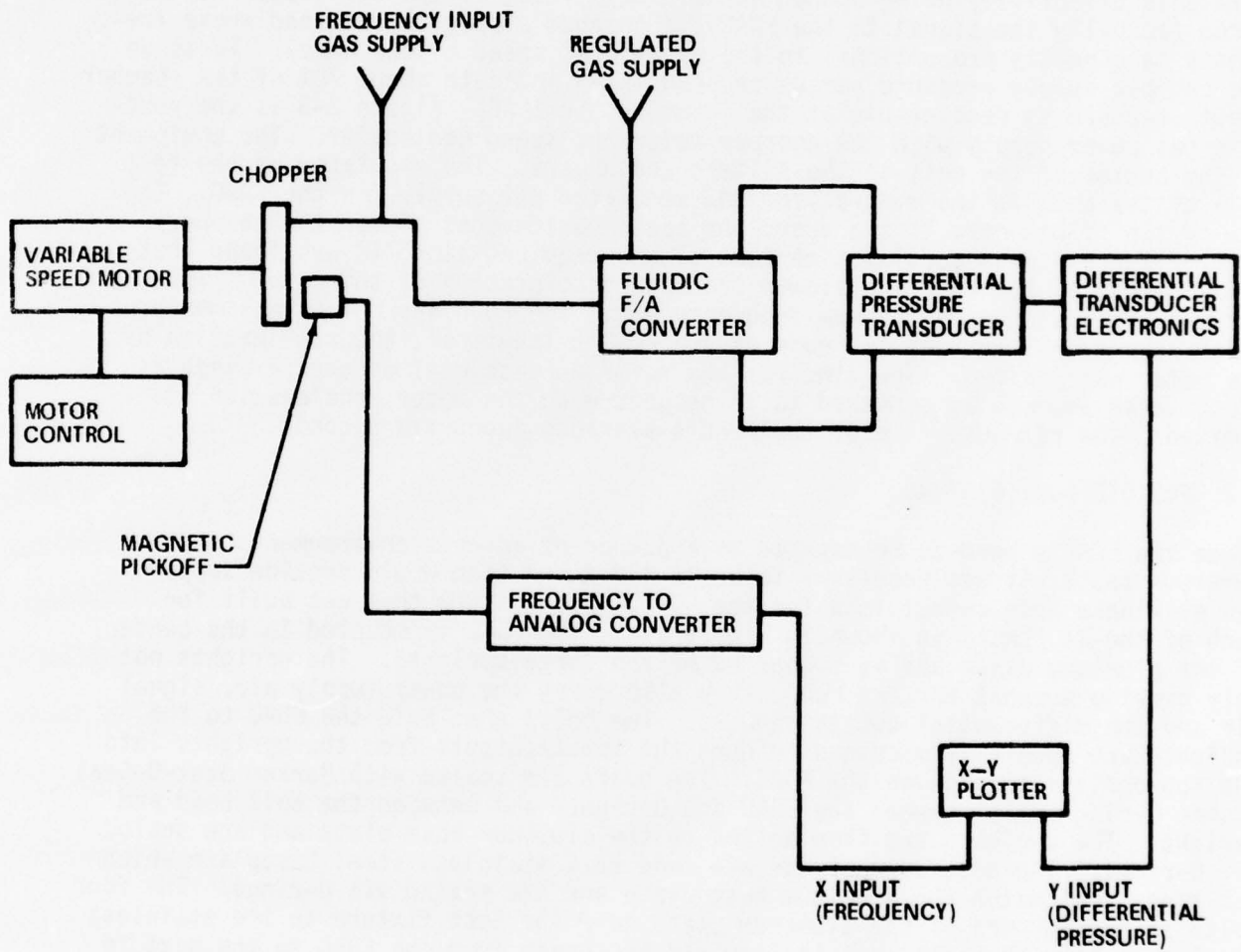

FIGURE 2-1 BLOCK DIAGRAM OF BASIC TEST SETUP

The chopper is shown in Figure 2-2. The wheel of the chopper is a timing belt gear pulley which was machined to .010 inch of the diameter to minimize the run-out of the teeth when passing through the air supply. The air supply nozzle is a group of six etched laminae, which are approximately one inch wide and .020 inch thick. This group of laminae form a chamber which is .001 inch from the teeth of the wheel; therefore, when the wheel is turning the laminate air chamber nozzle is effectively being opened and closed. Thus, if the air chamber is monitored (actually the signal to the FDAC), a chopped supply is obtained whose frequency is directly proportional to the rotational speed of the wheel. Tests on the chopped supply pressure versus chopped speed indicate about 70% of the chamber input pressure is recoverable at the input to the FDAC. Figure 2-3 is the portable gas power supply with the chopper motor and speed controller. The equipment on the bottom of the unit is the filters and dryers. The regulator on the left side of the unit is the control for the regulated air supply for the FDAC. The box on top of one cart is the speed and acceleration control for the chopper/chopper motor. This acceleration control was required since it was found that the response of the FDAC was slower than the acceleration of the motor. Thus, the chopper would be at maximum frequency while the FDAC was not at maximum pressure; therefore, to keep all runs of the FDAC's identical, the acceleration of the motor was limited. The time for the motor to reach maximum acceleration is about three seconds as compared to 12 seconds when the motor acceleration is limited. The response time of the FDAC's averages about six seconds.

2.2 FLUIDIC FUZE FIXTURE

Since the FDAC's were to be exposed to a number of adverse environments and numerous tests, it was necessary to build a fixture that would provide support and eliminate hose connections for the FDAC. The fixture that was built for each of the 21 FDAC's is shown in Figure 2-4. The FDAC is mounted in the center of the aluminum plate and is supported by the three uprights. The uprights not only provide support for the FDAC, they also carry the power supply air, signal air and the differential output signals. The bolts that hold the FDAC to the uprights are specially machined to duct the input/outputs from the uprights into the appropriate opening on the FDAC. The bolts are sealed with Parker Stat-O-Seal washer O-ring seals between the FDAC and uprights and between the bolt head and upright. The uprights are then bolted to the aluminum base plate and are sealed via O-rings. The hose connections are made to a stainless steel baseplate which has ports that match the aluminum base plate and are sealed via O-rings. The four bolts at the corners of the aluminum plate hold the test fixture to the stainless steel test bed; thus all that is required to change from one FDAC to the next is removal of the four corner bolts, removal of the test fixture, installation of the next FDAC under test and reinstallation of the four corner bolts. This procedure eliminates the necessity of making and breaking flow lines and possibly incurring leakage paths.

Figure 2-5 is the FDAC installed within the environmental chamber. The chamber provides a controlled pressure atmosphere via a sonic orifice. This allows the FDAC to function at essentially the same pressure as ambient at altitudes up to 90,000 feet. Nineteen of the FDAC's were exposed to adverse environments in the configuration shown in Figure 2-5. The Figure 2-4 configuration was only used during the initial testing and tuning of the FDAC's. The only problems experienced

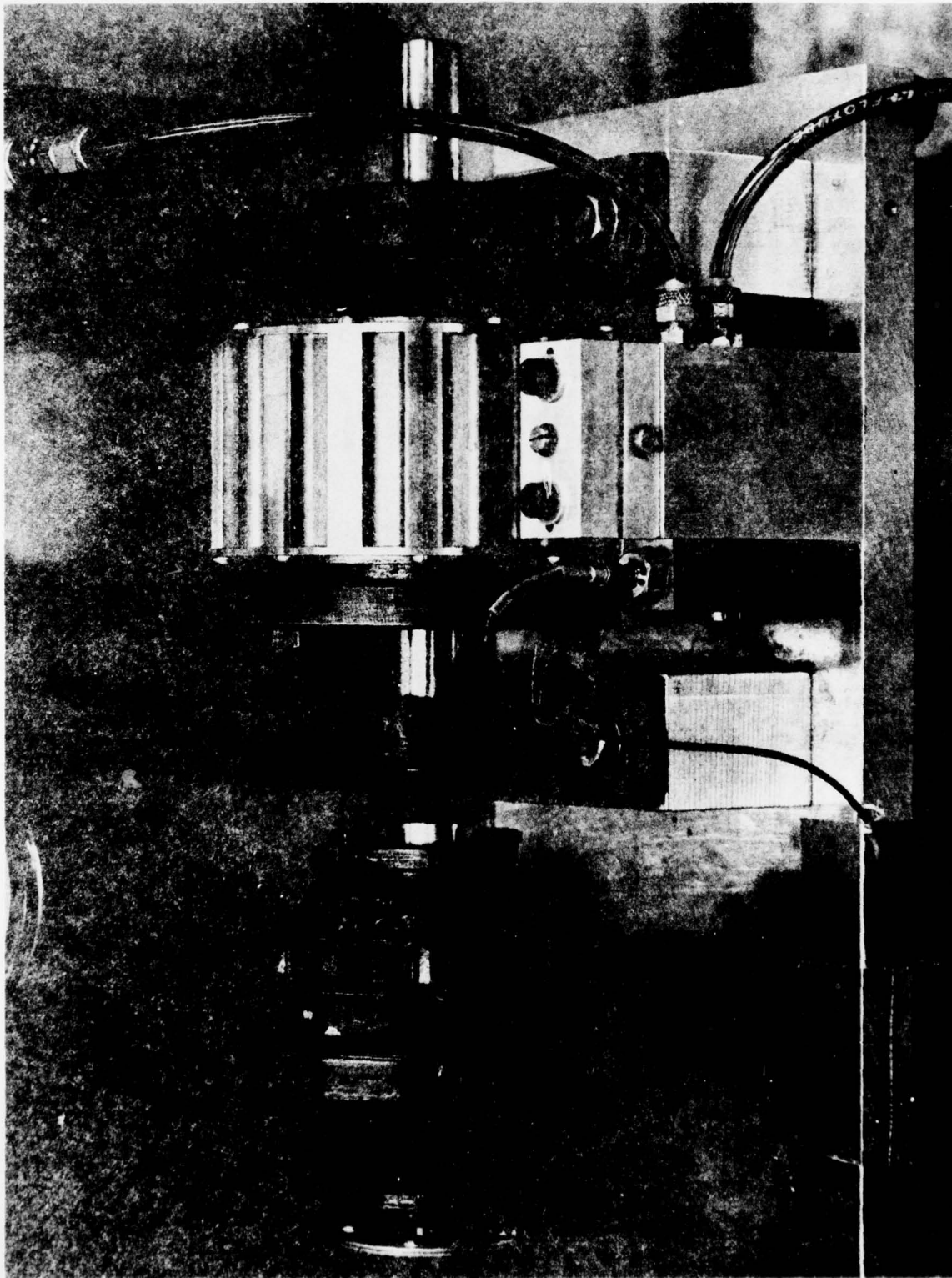

FIGURE 2-2 CHOPPER

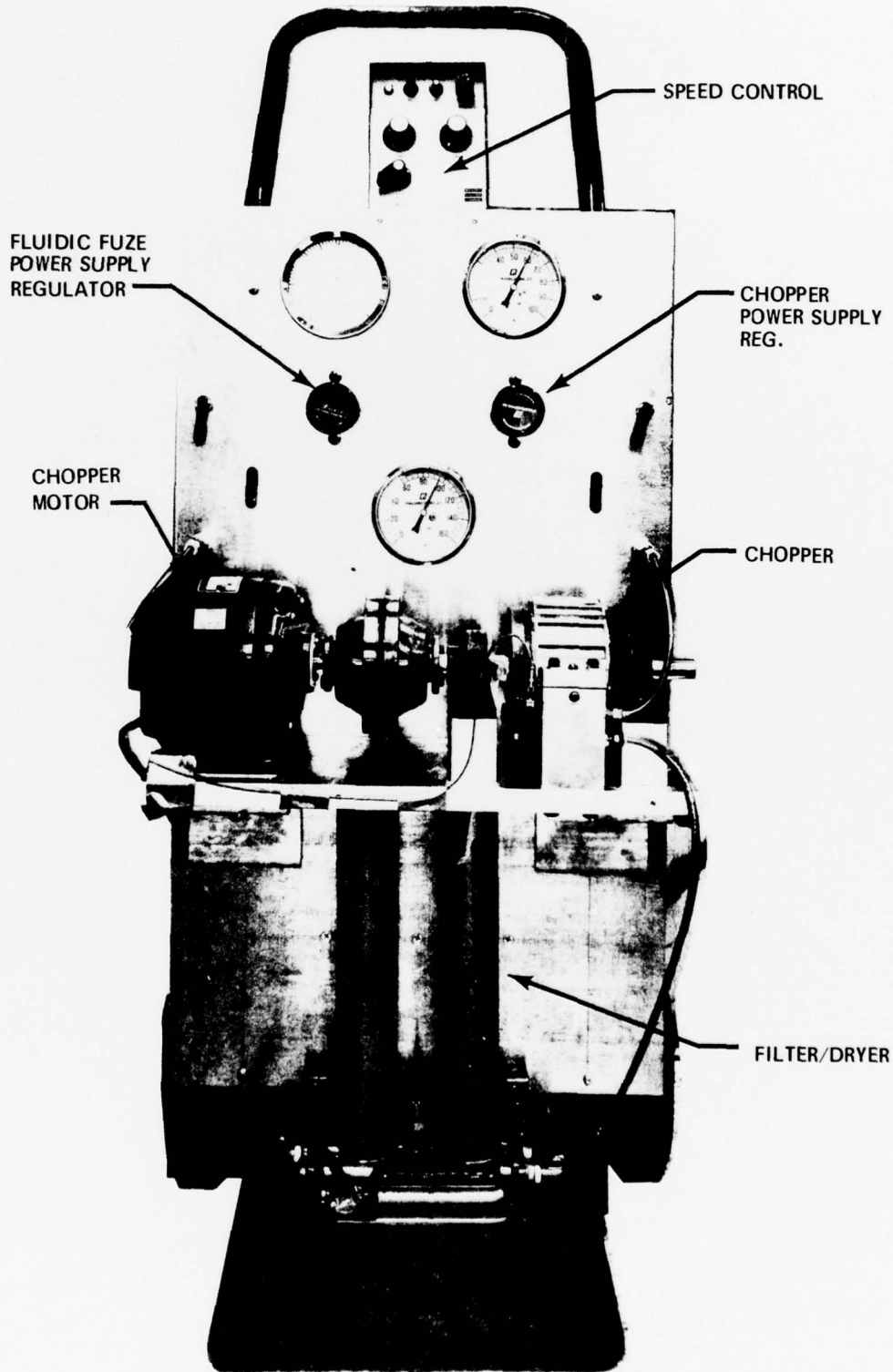

FIGURE 2-3 PORTABLE GAS POWER SUPPLY AND CHOPPER

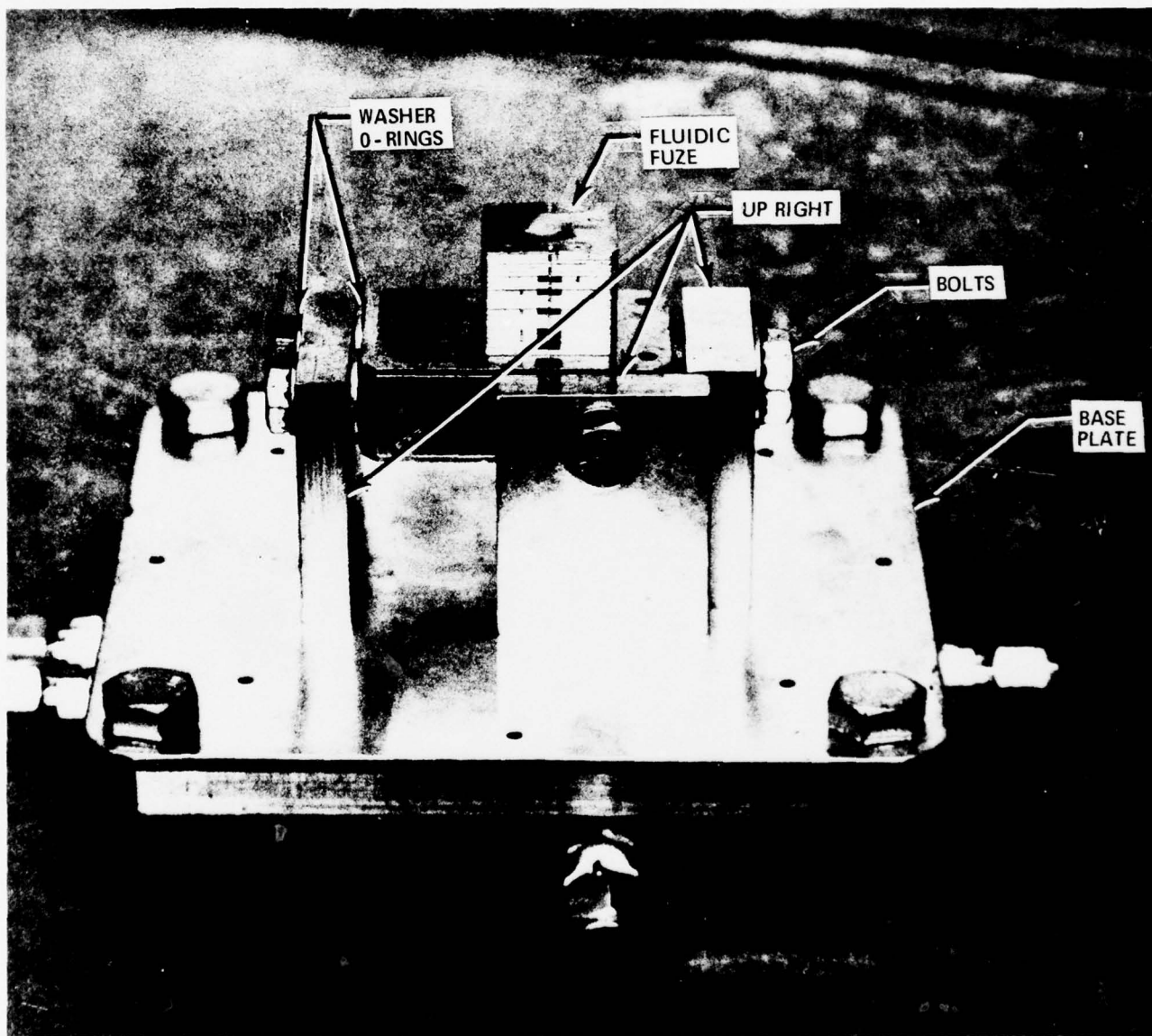

FIGURE 2-4 FLUIDIC FUZE MOUNTED ON TEST FIXTURE

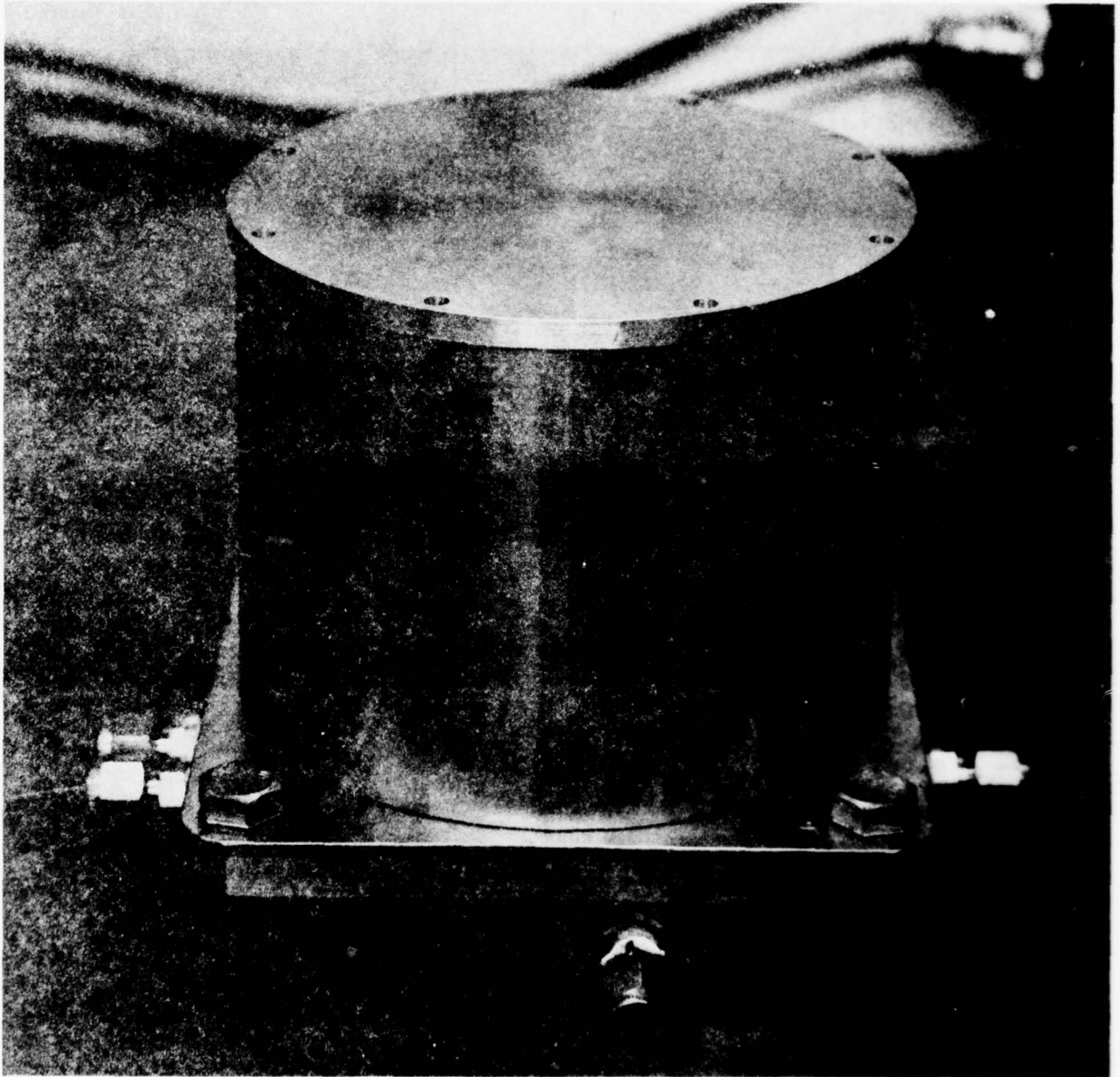

FIGURE 2-5 FLUIDIC FUZE ENVIRONMENTAL CHAMBER

with the environmental chamber test fixture was a susceptibility to sinusoidal vibration. Resonances of the test fixture were experienced at 1200, 1500 and 2000 Hz. These resonances were found to be extremely significant and, should the test fixture be used in a flight configuration, the environmental fixture should be redesigned. The resonances were an order of magnitude greater on the FDAC than was being applied; i.e., when a 1-g sinusoidal sweep was applied to the test fixture, the FDAC accelerometer saw 10 g's at the frequencies previously mentioned. Examination of the fixture showed the problem to be the aluminum baseplate which is 1/2 inch thick and 6 inches square. Had this plate been 1 inch thick, the problem would have been significantly reduced. Tests were run on the 1 inch baseplate to verify the previous investigation and the results of these tests indicate the 1 inch baseplate reduced the problem by approximately 90%.

2.3 AMBIENT (BASELINE) ENVIRONMENT EVALUATION

Ambient testing of the FDAC's to establish baseline performance curves was conducted both with and without the environmental chamber. Testing done without the chamber was primarily for familiarization, cleanliness, and tuning of the FDAC's. Testing done within the chamber gave the baseline data that was used for the environmental testing. Baseline or ambient testing was performed on all 21 units both before and after a specific environmental test sequence. The type of data or curves obtained from baseline testing are the same as the data for the environments; thus, any anomalies that occur during an environment are directly relatable to the baseline data.

2.4 STEP PULSING EVALUATION

During the performance of Task D and Task E (see Fig. 1-1) it was necessary to step pulse the FDAC when the FDAC was driving a Schmitt trigger and when it was connected in the normal manner (driving a differential pressure transducer). The Schmitt trigger used for this test was a General Electric Model MT11. The FDAC was set up in the normal manner (40 psi supply pressure). An X-Y recording was made that had pressure on the Y coordinate and time on the X coordinate. The test flow was to start the recorder (X axis sweep at 1 in/s) and then apply the signal input pressure at 500 Hz. This yielded a trace from which response time for the Schmitt trigger and the FDAC could be obtained.

The Schmitt trigger test was conducted only once throughout the program; however, the step pulsing was done both before and after the adverse environments (Task F).

2.5 ADVERSE ENVIRONMENTS

As previously mentioned, the adverse environments were high temperature, low temperature, acceleration, vibration, acoustical noise and altitude. Nineteen of

the twenty-one units were exposed to all the environments. The two units which were not exposed (S/N's 6 and 36) were baseline tested on the environment test setup both before and after the environment. This baseline data was used to verify that the environment test setup did not change; it also yielded data that would insure that the FDAC's did not degrade with time.

2.5.1 Temperature Evaluation

A Delta Model MK6300 temperature chamber was used for both the high and low temperature tests. Figure 2-6 is the temperature setup (with the front doors removed) for both the high and low temperature conditions. The gas coming into the units was preheated/cooled via the copper tube coils. The temperature of the air was measured at the output orifice of the FDAC and compared to the oven temperature; the maximum difference was 3° F. The FDAC's were preconditioned for approximately four hours before testing. Figure 2-6 shows that while one unit was under test, several other units were within the chamber; this was done to facilitate testing, since the units within the chamber were already conditioned and could be tested immediately. High temperature (+165°F) testing was performed without any problems; however, during low temperature (-40°F) testing, several icing problems occurred. The first unit that was tested at low temperature exhibited severe icing of the input supply air. This situation was corrected by using bottled dry nitrogen gas with a dew point of -65°F. Baseline data after the low temperature testing was also performed with dry nitrogen gas so that a reasonable comparison could be made between the dry nitrogen and conditioned shop air that was used during all other testing.

2.5.2 Acceleration Evaluation

Figure 2-7 shows a unit installed on the Genisco centrifuge that was used for the acceleration testing. Nineteen of the twenty-one specimens were subjected to acceleration per MIL-STD-810B, Method 513.1, Procedure II. Acceleration level was 25 g's applied along axes +1, -1, +3 and -3 for a period of two minutes, minimum, in each direction. Definition of the specimen axes is shown in Figure 2-8. Supply and signal air entered the FDAC via pneumatic slip rings. The output of the FDAC was measured with the differential pressure transducer which was mounted in the center of the Genisco table and the signals of the transducer were monitored through the electrical slip rings. Three performance curves were recorded during each acceleration test. Before and after completion of the acceleration test, three baseline performance curves were recorded for each of the twenty-one FDAC's.

2.5.3 Vibration Evaluation

Vibration testing was performed on a Ling Model 300 electro-dynamic vibration test machine driven by a Ling Model PP-70/120 power amplifier. This system was controlled by a Spectral Dynamic SP 114 Sweep Oscillator Sensor and a Model SD-117

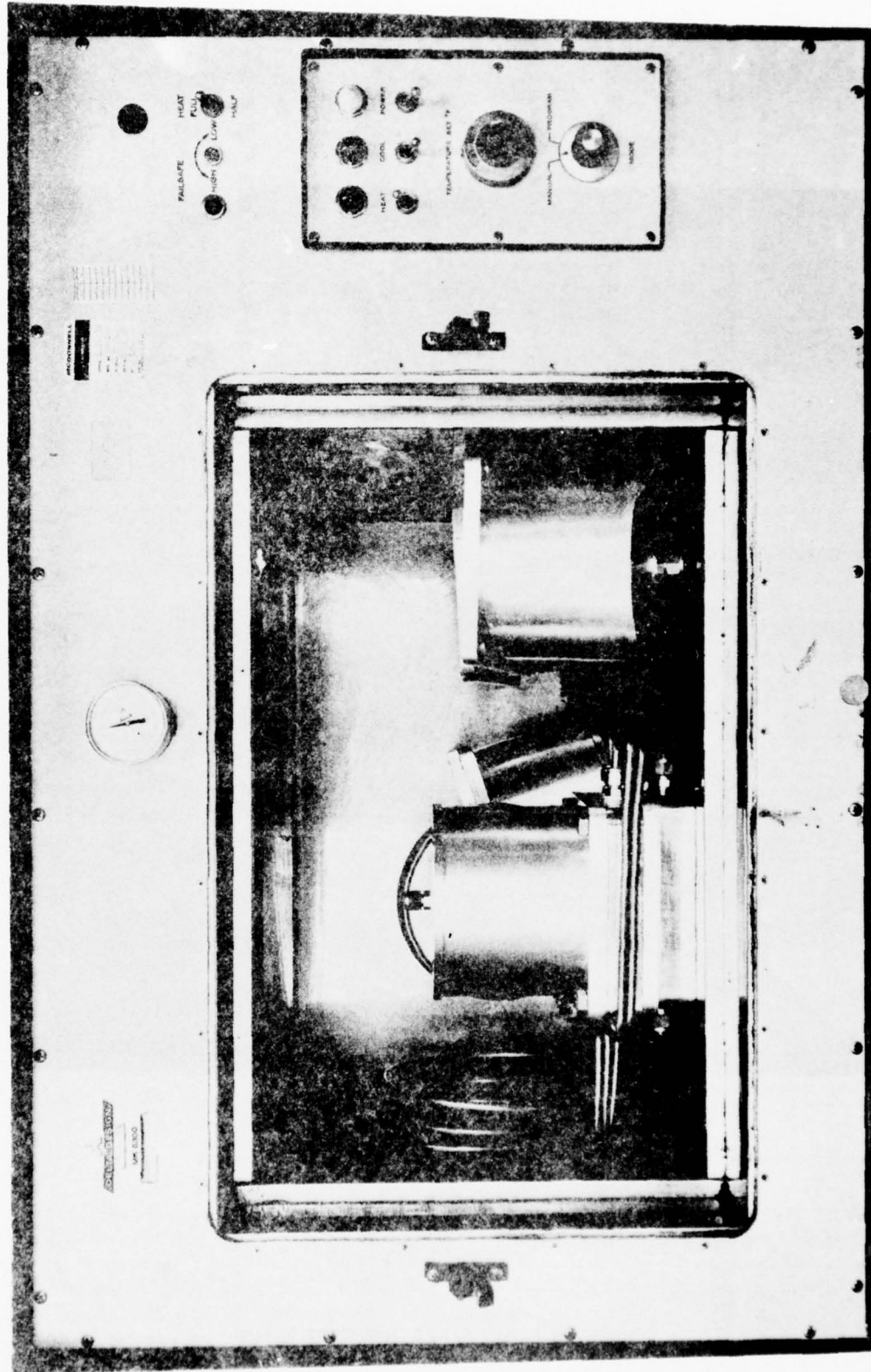

FIGURE 2-6 HIGH AND LOW TEMPERATURE TEST SETUP

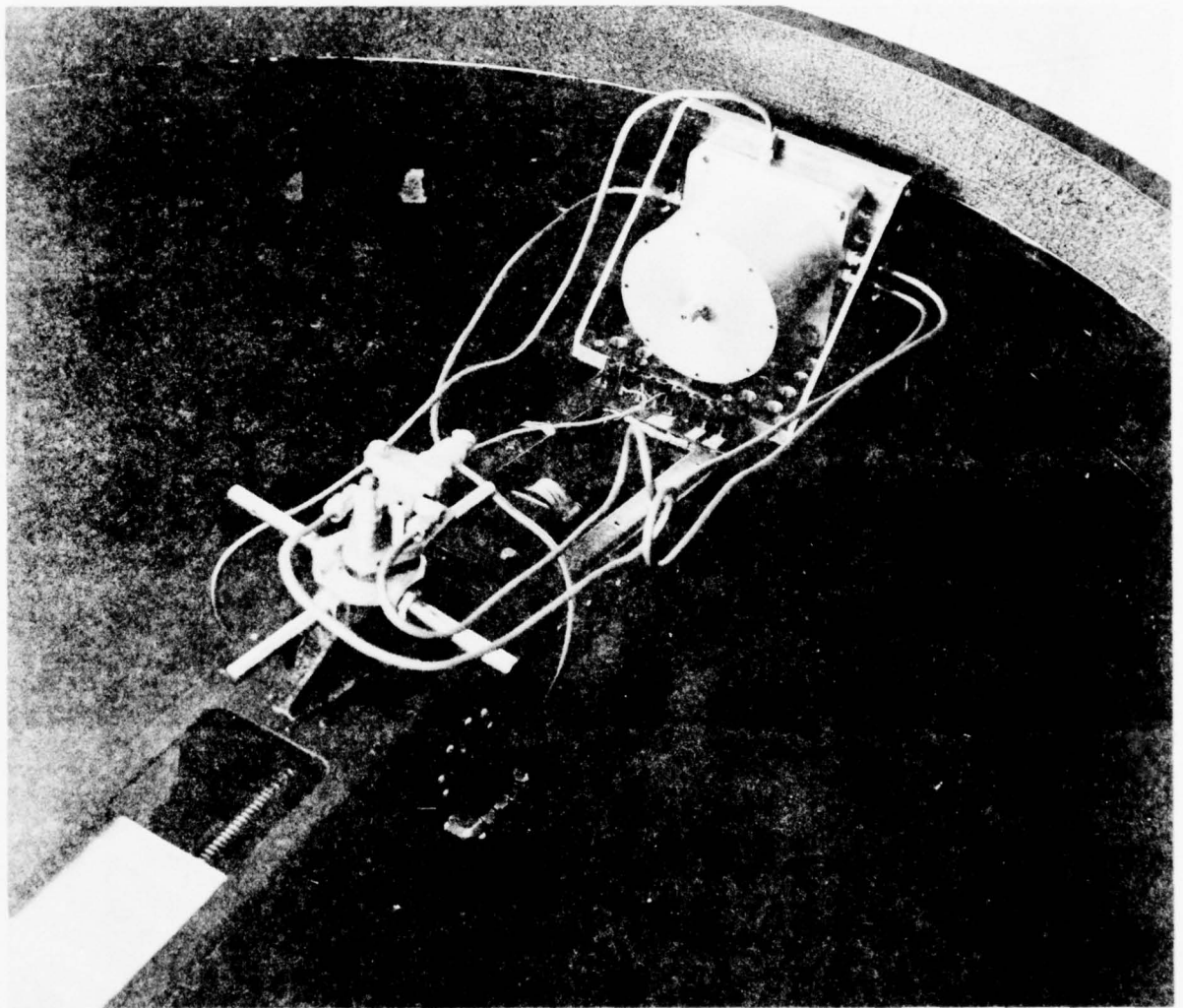

FIGURE 2-7 ACCELERATION TEST SETUP

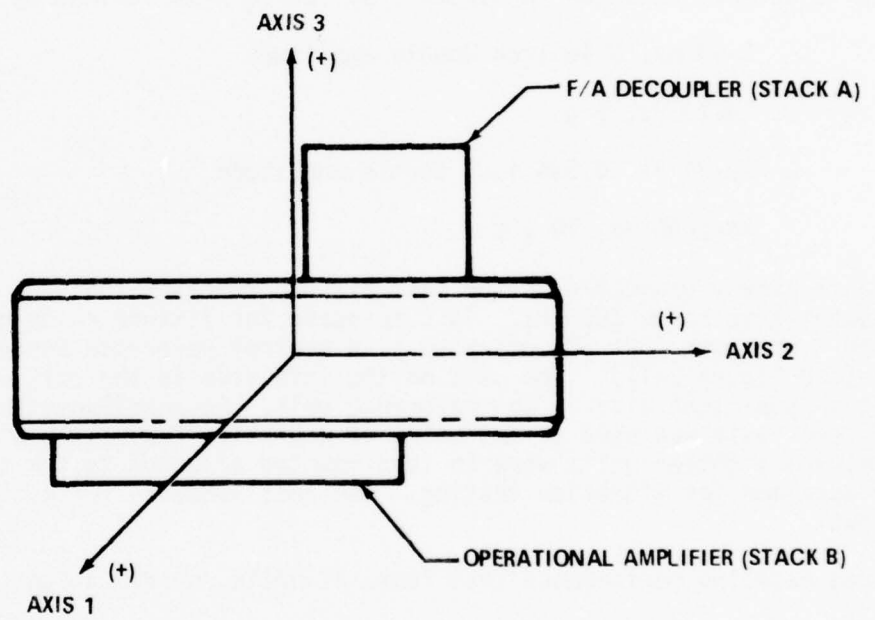

FIGURE 2-8 TEST AXES

Automatic Level Programmer to provide sinusoidal vibration. Random vibration was achieved by driving the system with an MB Model T598 automatic spectrum equalizer/analyzer. Vibration testing, both sinusoidal and random, was conducted per MIL-STD-810B, Method 514.1, Category D, Procedure IV. Specimens were tested in Axes 1 and 3. Curves H and AG were used for sinusoidal and random vibration respectively.

Curve AG is defined as shown in Figure 2-9. Curve H is defined as:

- 5-14 Hz, 0.10 inch double amplitude
- 14-23 Hz, 1 g
- 23-74 Hz, 0.036 inch double amplitude
- 74-2000 Hz, 10 g's

A resonance survey conducted on the test fixture revealed that the fixture was not resonant-free below 2000 Hz. To compensate for fixture resonance, one fixture with a specimen (S/N 32) was used as a control reference during vibration testing (see Figure 2-11). The unit on the left side is the unit under test; the unit on the right side is the reference unit. An accelerometer installed on the reference unit was used as the point of vibration feedback control. Each of the remaining eighteen units were in turn mounted adjacent to the controlled reference specimen for vibration testing. The test sequence for each specimen was as follows:

- (a) Three baseline performance test runs, 21 units, no vibration.
- (b) Sinusoidal vibration, Axis 3, 18 units, one 20 minute sweep (5-2000-5 Hz), per unit. Specimen was operated with input frequency controlled at 400 Hz and output differential pressure was recorded on an X-Y recorder versus vibration frequency.
- (c) Random vibration, Axis 3, 18 units, thirty minutes duration per unit. Three performance test runs were conducted during application of the random vibration; one at the start, one midway and one at the end.
- (d) Items (b) and (c) were repeated for Axis 1 for 18 units.
- (e) Three performance test runs, 21 units, no vibration.

2.5.4 Acoustical Evaluation

Acoustical environment testing was performed at the McDonnell Douglas St. Louis facility. The equipment used was a matched set of Wyle Modulated Air Horns, which were driven and monitored by a Bovel-Kjaer precision amplifier and microphone. The

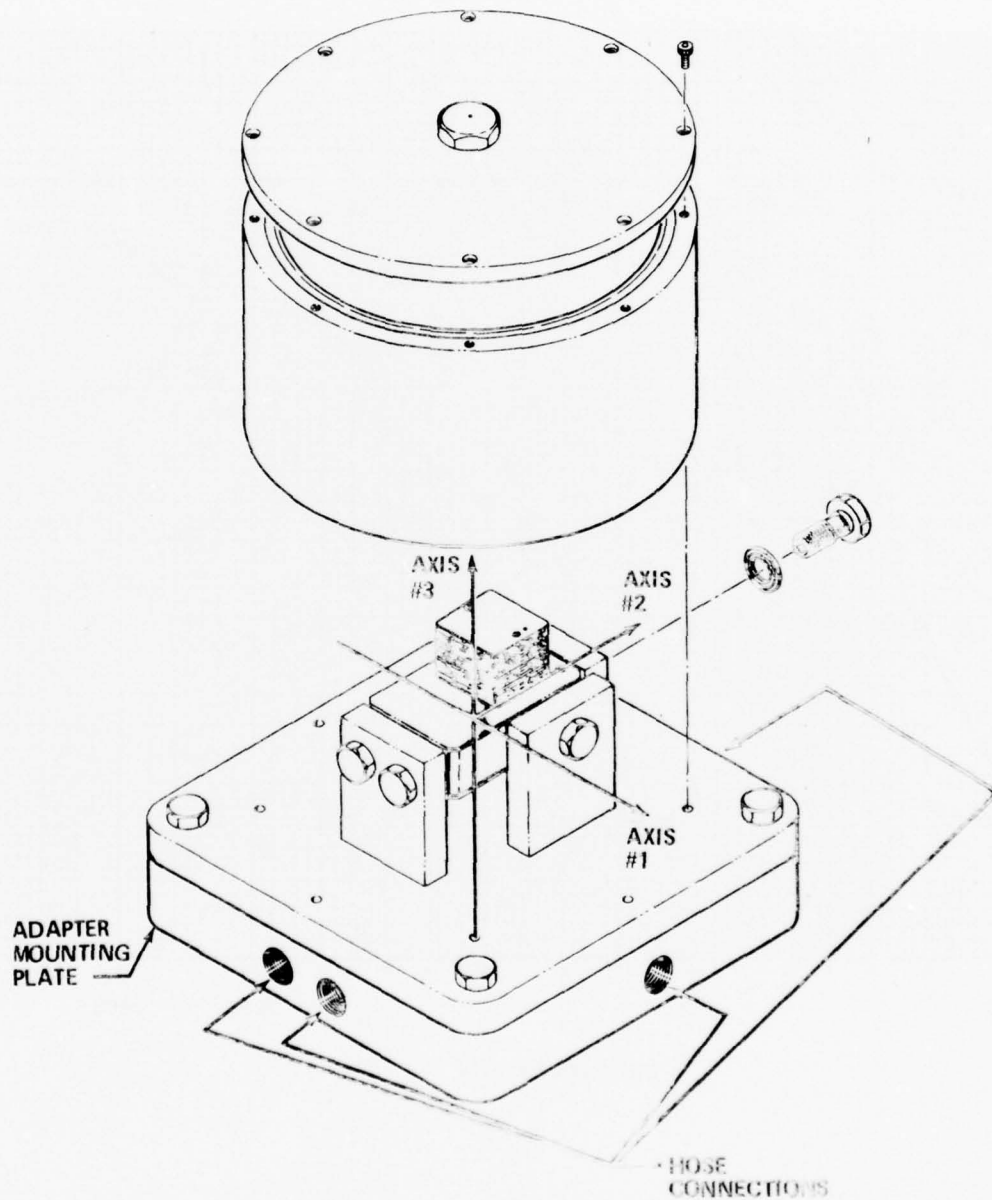

FIGURE 2-9 TEST FIXTURE AND ACCELERATION AXES

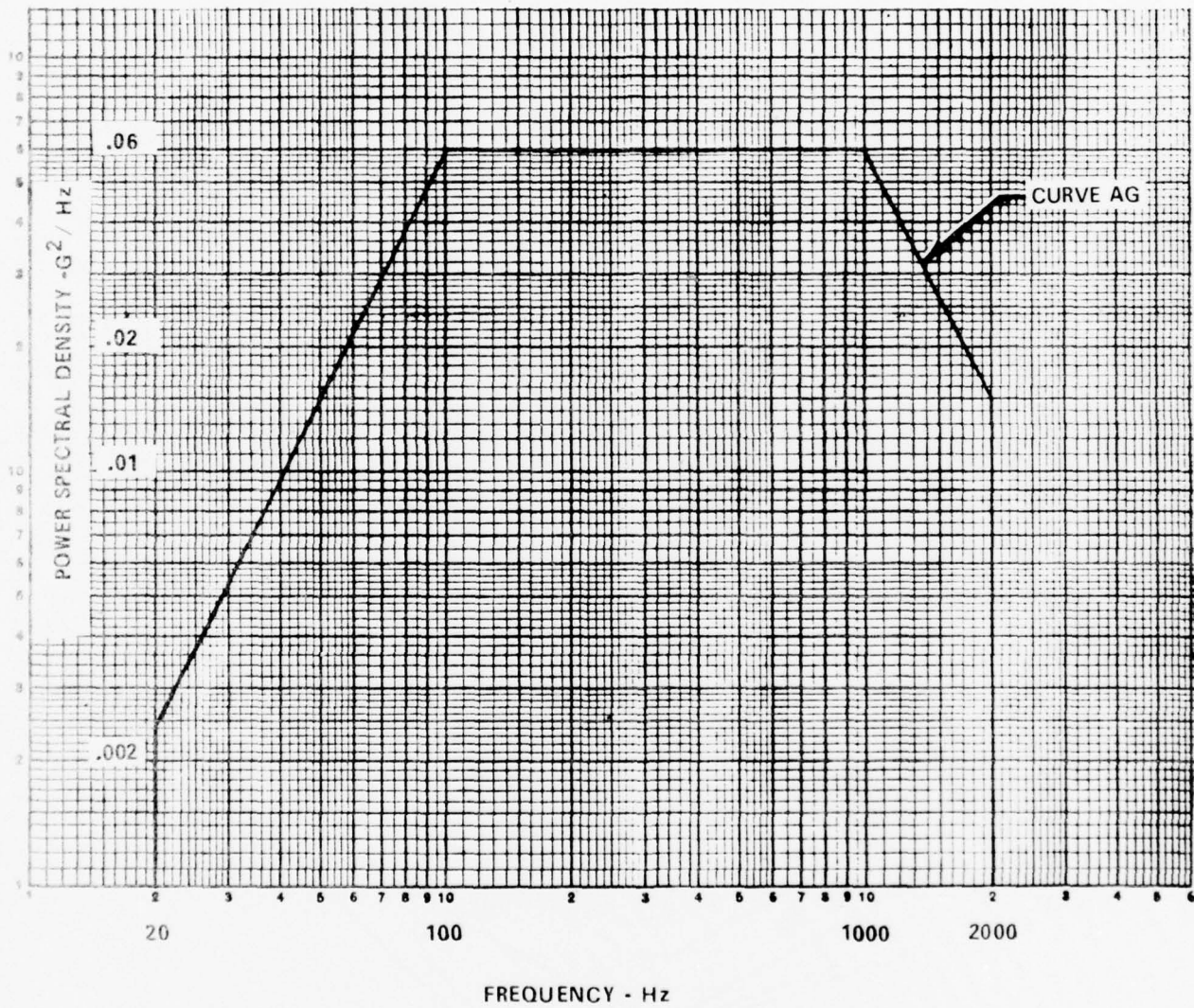

FIGURE 2-10 REQUIRED RANDOM VIBRATION TEST INPUT CURVE (9.3 GRMS OVER-ALL)

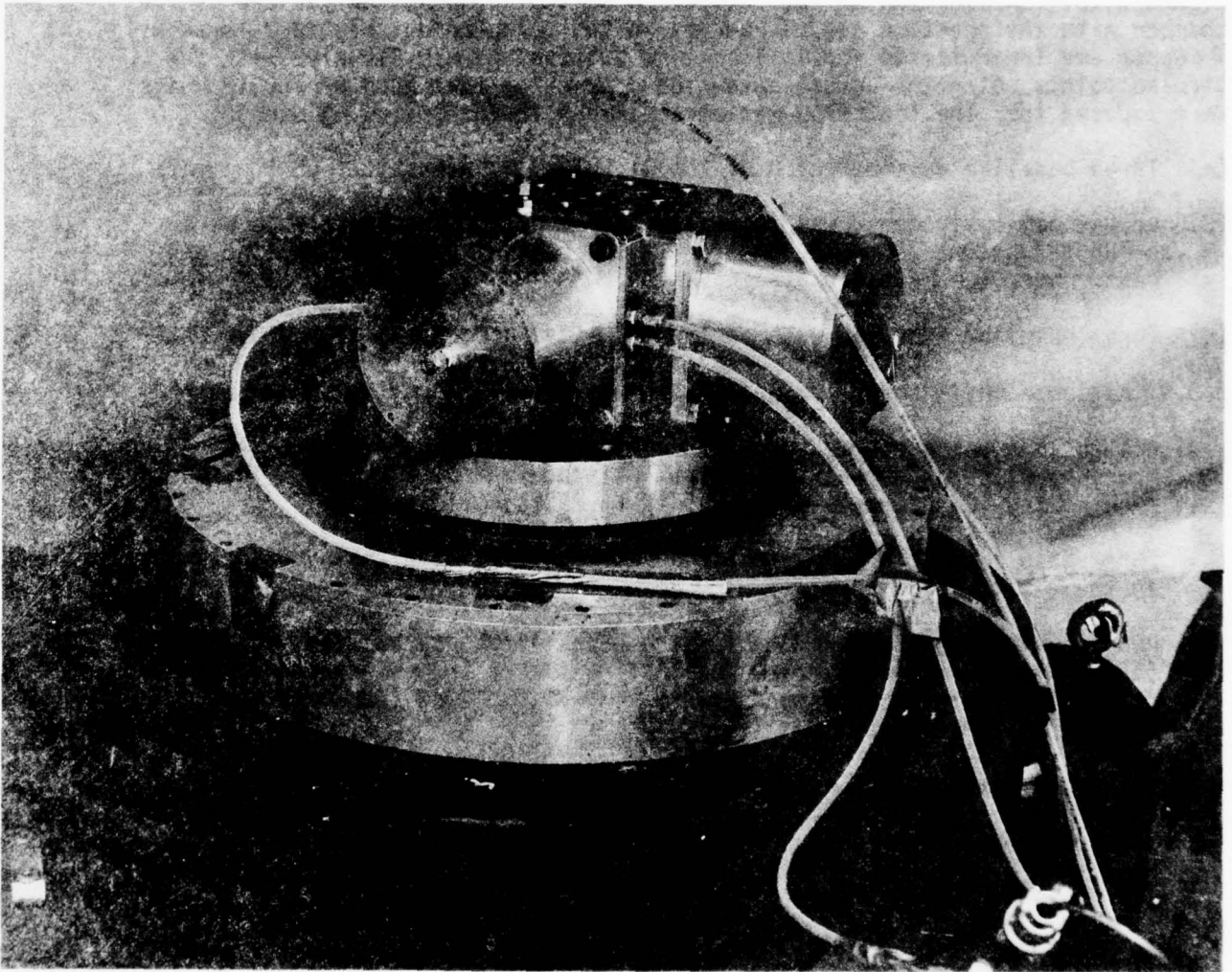

FIGURE 2-11 VIBRATION TEST SETUP SHOWING UNIT UNDER TEST AND CONTROL UNIT

acoustical environment was per the conditions of MIL-STD-810B, Method 515.1, Category C, for rockets (eight minute exposure). The test setup is shown in Figure 2-12. Examination of the chamber shows the horns at the far end of the chamber with the specimen and microphone in the foreground. Figure 2-13 shows the upper and lower limits (solid lines) as outlined by MIL-STD-810B with the circled points being the actual octave band spectrum that each of the 19 units were exposed to. The test flow was accomplished in the following manner:

- (a) Three baseline runs per each of the 21 units, no acoustical environment.
- (b) Acoustical environment was initiated; three performance test runs were conducted on the 19 units, one run at the beginning, one midway and one performance run at the end.
- (c) Three baseline runs per each of the 21 units, no acoustical environment.

2.5.5 Altitude Environment

Altitude testing was performed per the requirements of MIL-STD-810B, Method 500, Procedure I, except that the maximum altitude was 90,000 feet. The sequence that each of the 19 specimens were exposed to is as follows:

- (a) Three baseline performance test runs at sea level with the specimen installed in the altitude chamber.
- (b) Pump down chamber to maximum altitude capability, approximately 90,000 feet (13.03 mm Hg). Three performance test runs were then conducted at altitude. Chamber pressure decayed to approximately 79,000 feet (22.78 mm Hg) by the end of the third run.
- (c) Three performance runs at each of 50,000, 25,000 and 10,000 feet altitude.
- (d) Three performance runs at sea level.

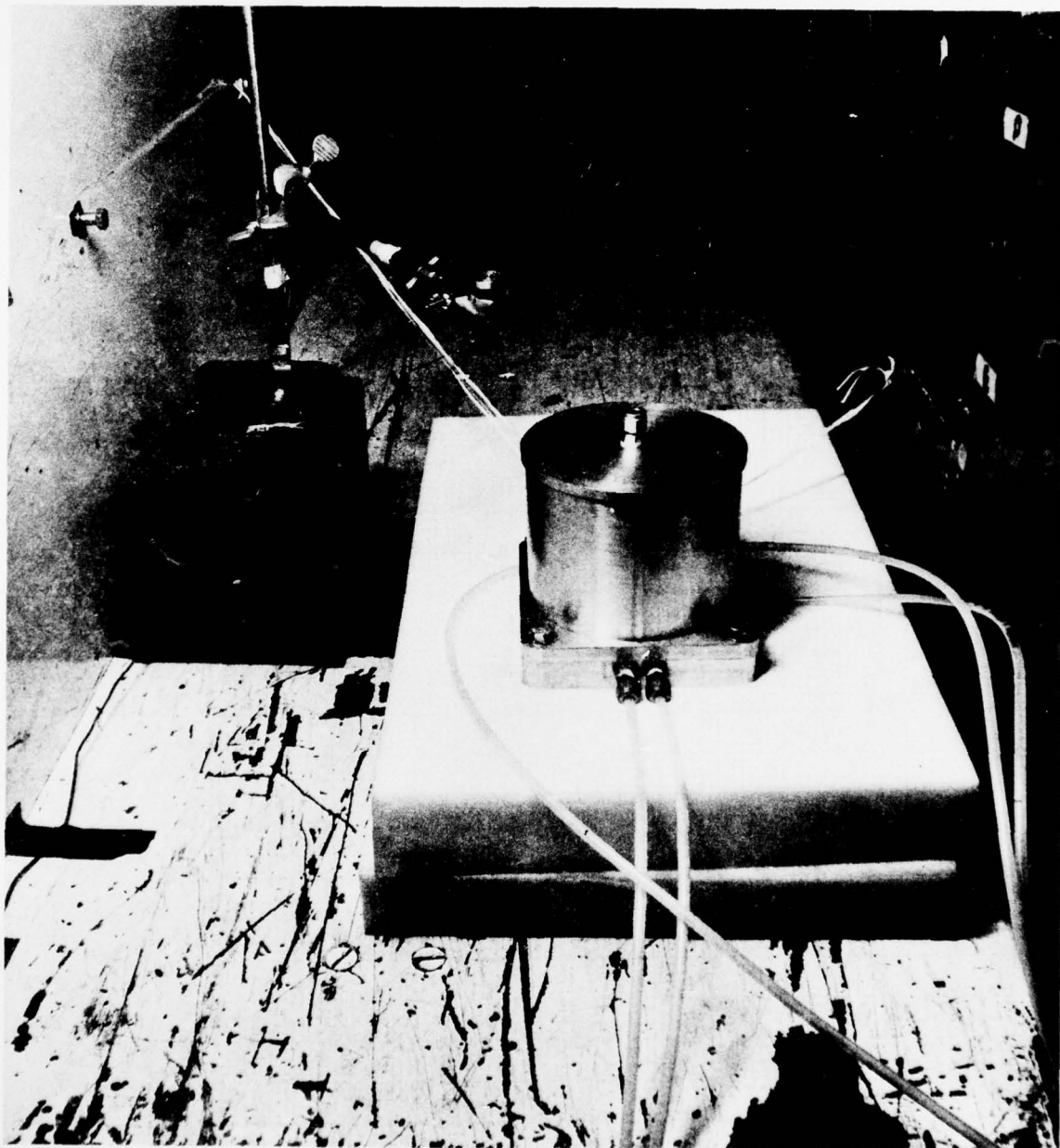

FIGURE 2-12 ACOUSTICAL TEST SETUP

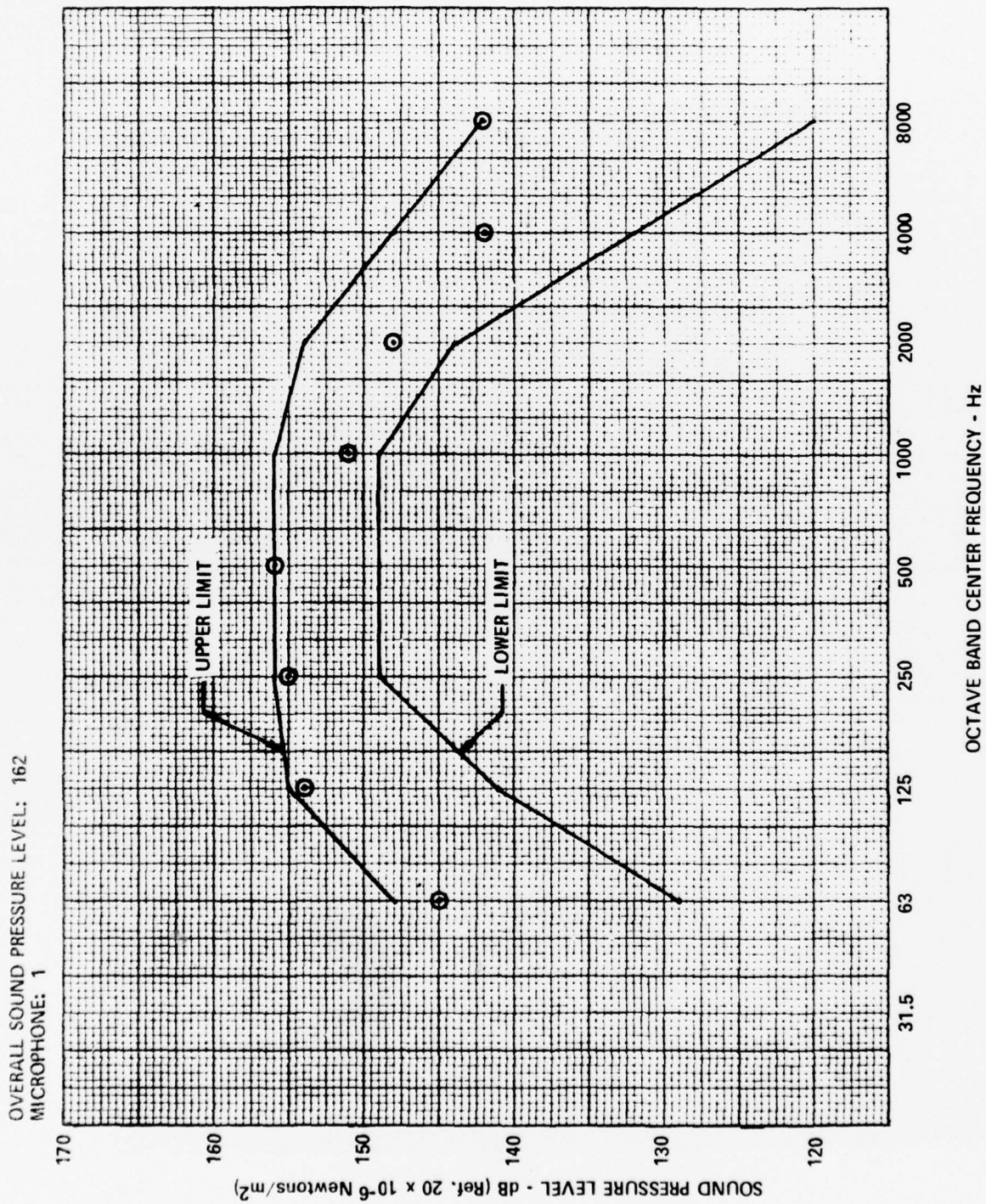

FIGURE 2-13 OCTAVE BAND SPECTRUM ANALYSIS

2.6 TEST EQUIPMENT

The following is a list of test equipment that was used for all testing of the FDAC's.

<u>NOMENCLATURE</u>	<u>MODEL</u>	<u>SERIAL NUMBER</u>
Gas Cart	-	MDAC-1
Chopper	-	MDAC-1
Speed Control - Bodine	ASH-502	907VD103
Motor - Bodine	NSH-54	280YA086
Kistler Charge Amplifier	504	1923
Kistler Charge Amplifier	504A04	1713
Kistler Transducer	606L	1494
Kistler Transducer	606L	1795
Scope - Tektronix	556	2727
Plug-In - Tektronix	CA	58650
Plug-In - Tektronix	1A1	982
Frequency Meter - Hewlett Packard	5210A	752-00899
X-Y Recorder - Hewlett Packard	7035A	646-1170
X-Y Recorder - Hewlett Packard	7047A	1422A00130
Voltmeter - Hewlett Packard	3440A	A501380
Voltmeter Plug-In - Hewlett Packard	3443A	A501206
Fluke - DC Standard	335A	A501252
Pace Carrier Modulator	CD10	20939
Pace Transducer	KP15	23175
Heise Pressure Gauge	C	H50043

SECTION 3

TEST RESULTS

Results of the test program discussed in this section include evaluation under ambient and environmental conditions. Twenty-one FDAC's were tuned and tested at ambient conditions to establish baseline performance, and then 19 of the 21 were subjected to evaluation under the adverse environments.

This section first discusses the units and the condition in which they were received. This is important because the units were manufactured approximately four years ago, were not treated with controlled care and were subsequently subjected to the environmental tests. In examination of the data/test results, care and judgement will be necessary to determine those anomalies that are due to contamination and those that are due to actual environments.

3.1 RECEIVED CONDITION OF FDAC'S

The units, when received, had several discrepancies which led MDAC TICO to record their condition. The following list of discrepancies and Figure 3-1 describe the discrepant conditions. Photographs of each FDAC are included in Appendix A.

<u>Fluidic Fuze Serial Number</u>	<u>Remarks</u>
4	Vents 1, 3 and 5 deformed, decoupler F/A dented
5	Vents 2, 7 and 9 severely deformed, decoupler F/A dented
6	Vents 2, 4, 8 and 9 deformed
7	Vents 4, 6 and 9 severely deformed, tuning orifice scratched

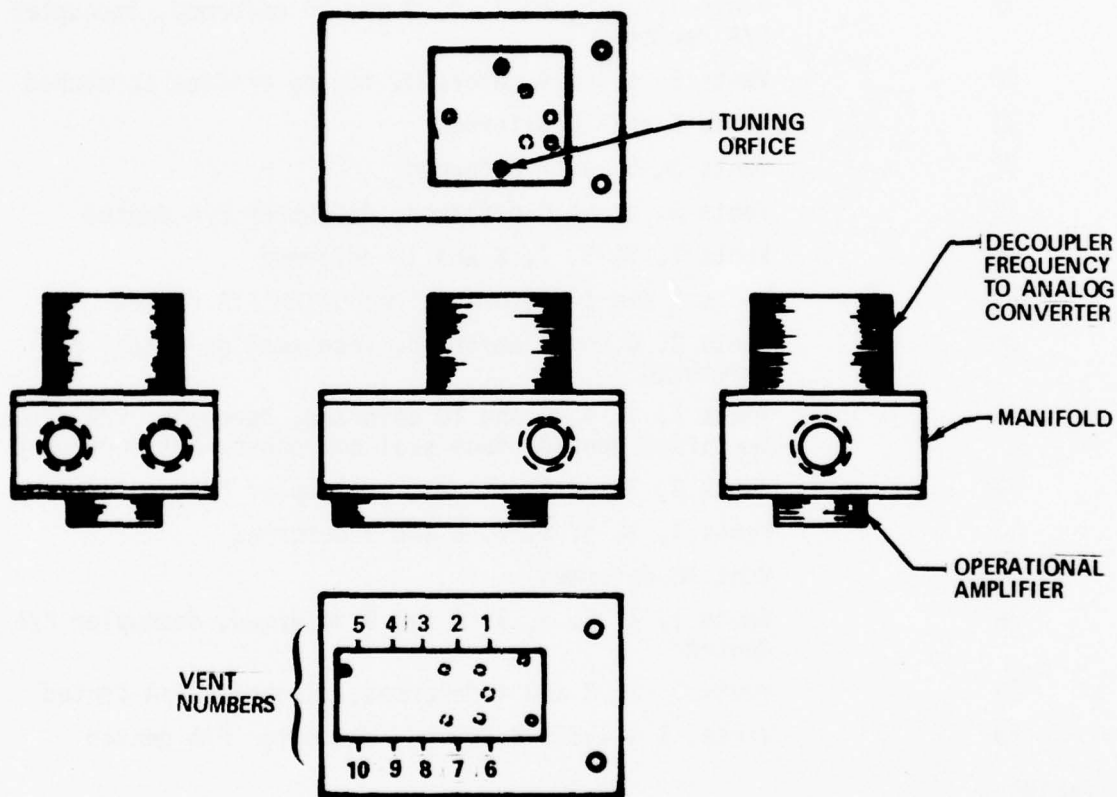

FIGURE 3-1 FLUIDIC FUZE

<u>Fluidic Fuze Serial Number</u>	<u>Remarks</u>
9	Vents 5 and 9 deformed, decoupler F/A dented
16	Vents 4, 7 and 10 deformed, tuning orifice scratched
17	Vents 1, 2, 5, 6, 7, 8, 9 and 10 deformed, decoupler F/A dented
20	Vents 5, 6 and 8 deformed, tuning orifice scratched
21	Vents 6 and 10 deformed
22	Vents 3, 5 and 7 deformed
25	Vents 3, 5 and 8 deformed, decoupler F/A dented
28	Vents 1, 3, 5, 7, 8 and 10 deformed
29	Vents 1 and 10 deformed, decoupler F/A dented
30	Vents 2, 6 and 7 deformed, face seal on signal port scratched
31	Vents 1, 3, 4, 6 and 10 deformed, decoupler F/A dented, amplifier dented, face seal on output port scratched
32	Vents 2, 3 and 4 deformed, decoupler F/A dented
33	Vents 1, 3, 4, 5, 6, 8 and 9 deformed
34	Vent 10 deformed
36	Vents 1, 2, 3, 5, 7, 8 and 9 deformed, decoupler F/A dented
38	Vents 1, 2, 3 and 4 deformed, decoupler F/A dented
39	Vents, 1 3 and 5 deformed, decoupler F/A dented

3.2 CLEANING

When the units were originally received, both HDL and MDAC intended the FDAC's to be cleaned in an ultrasonic cleaner Trichloroethylene (TRIC) bath. The FDAC's were exposed to the ultrasonic bath in each axis for ten minutes (total of 60 minutes per unit).

After the ultrasonic cleaning was completed a baseline test was performed (see Tables 3-1, 3-2 and 3-3 for results). Review of these data indicated the units were extremely erratic and probably still contaminated. Therefore, it was decided that the ultrasonic cleaning was not sufficient and another cleaning method had to be devised. Many methods were tried and a backflush method was found to be superior.

TABLE 3-1
BASELINE DATA BEFORE BACKFLUSH CLEANING IN TRIC
FREQUENCY AT -5 PSI

RUN	1	2	Δ	3	4	Δ	5	6	Δ	7	8	Δ	9	10	Δ	MAX Δ/ AVG Δ	# OF RUNS	MIN	MAX	Δ	AVG
S/N																					
4	339.4	335.6	3.8	345.4	342.9	2.5	344.6	344.6	0	339.5	338.6	0.9	346.3	346.3	0	3.8/1.4	10	335.6	346.3	10.7	342.3
5	362.9	363.6	0.7	362.8	364.5	1.7	366.2	368.7	2.5	363.6	360.2	3.4	367	364.9	2.1	3.4/2.1	10	360.2	368.7	8.5	364.4
6	400	400	0	281.8	-	-	268.7	264.5	4.2	270.4	271.3	0.9	277.6	275	2.6	4.2/1.9	9	264.5	400	135.5	301
7	405.3	402.3	3.0	400	400	0	400	401.7	1.7	396.3	400	3.7	401.7	400	1.7	3.7/2.0	10	396.3	405.3	9	400.7
9	342.4	350	7.6	350	354.3	4.3	350	351.7	1.7	355.1	355.9	0.8	358.5	356.8	1.7	7.6/3.2	10	342.4	358.5	16.1	352.5
16	334.1	325	9.1	450	447.9	2.1	510.2	507.7	2.5	510.2	509.4	0.8	510.2	508.5	1.7	9.1/3.2	10	325	510.2	185.2	461.3
17	362.1	361.4	0.7	365	364.5	0.5	367	365.3	1.7	368.7	367	1.7	368.7	373.8	5.1	5.1/1.9	10	361.4	373.8	12.4	366.4
20	377.3	380.3	3.0	375	370.4	4.6	365.3	368.7	3.4	367	369.6	2.6	367.9	366.2	1.7	4.6/3.1	10	365.3	380.3	15	370.8
21	340.2	350	9.8	343.7	345.4	1.7	342.9	343.7	0.8	350	348	2.0	350	348.3	1.7	9.8/4.4	10	340.2	350	9.8	346.2
22	355.3	352.3	3.0	361.1	361.1	0	354.3	355.9	1.6	355.1	354.3	0.8	356.8	354.3	2.5	3.0/1.6	10	352.3	361.1	8.8	356.1
25	342.7	342.7	0	344.6	343.7	0.9	344.6	343.7	0.9	348	345.4	2.6	340.3	342.4	2.1	2.6/1.3	10	340.3	348	7.7	343.8
28	333.3	331	2.3	321.3	317	4.3	315.3	320.4	5.1	321.3	321.7	0.4	324.7	328.4	3.7	5.1/3.2	10	315.3	333.3	18	323.5
29	340.2	350	9.8	345.4	342.9	2.5	325	325	0	324	325	1.0	330.1	320.9	0.8	9.8/2.8	10	324	350	26	333.9
30	325	323	2.0	322.1	325	2.9	322.1	319.6	2.5	321.3	322.1	0.8	324.7	310.3	14.4	14.4/4.5	10	310.3	325	14.7	321.5
31	268.9	265.2	3.7	270.4	275	4.6	268.7	268.7	0	271.3	268.7	2.6	271.3	271.3	0	4.6/2.2	10	265.2	275	9.8	269.9
32	284.1	285.6	1.5	287.8	287.8	0	286.9	286.1	0.8	287.8	285.2	2.6	287.8	285.2	2.6	2.6/1.5	10	284.1	287.8	3.7	286.4
33	363.6	360.6	3.0	361.1	360.2	0.9	356.8	356.8	0	358.9	371.3	12.4	376.7	371.3	5.4	12.4/4.3	10	356.8	376.7	19.9	363.7
34	288.7	285.5	3.2	353.4	352.6	0.8	360.2	356.8	3.4	340.3	341.2	0.9	342	345.8	3.8	3.8/2.4	10	285.5	360.2	74.7	336.9
36	337.9	338.6	0.7	335.2	331.8	3.4	327.6	332.7	5.1	335.2	331.8	3.4	333.1	334.4	1.3	5.1/2.8	10	327.6	338.6	11	333.8
38	325	324.2	0.8	321.3	315.3	6.0	322.9	319.6	3.3	319.6	319.6	0	321.3	320.4	0.9	6.0/2.2	10	315.3	325	9.7	320.9
39	265.2	267.7	2.5	271.3	275	3.7	240.3	287.8	47.5	265.3	271.3	6.0	268.7	284.4	15.7	47.5/15.1	10	238.6	287.8	49.2	265.9

TABLE 3-2
BASELINE DATA BEFORE BACKFLUSH CLEANING IN TRIC
FREQUENCY AT 0 PSI

RUN S/N	1	2	Δ	3	4	Δ	5	6	Δ	7	8	Δ	9	10	Δ	MAX Δ / AVG Δ	# OF RUNS	MIN	MAX	Δ	AVG
4	391.7	388.1	3.6	390.3	390.3	0	387.8	390.3	2.5	387.8	386.9	0.9	387.8	387.8	0	3.6/1.4	10	386.9	391.7	4.8	388.9
5	417.9	411.9	6.0	412.8	417	4.2	415.3	418.7	3.4	413.6	406.8	6.8	412.8	415.3	2.5	6.8/4.6	10	406.8	418.7	11.9	414.2
6	457	450	7.0	328.4	-	-	315.3	306.8	8.5	316.2	315.3	0.9	320.4	317	3.4	8.5/5.0	9	306.8	457	150.2	347.4
7	459.7	454.8	4.9	450	453	3.0	451.7	453.4	1.7	447.1	450	2.9	454.3	453.4	0.9	4.9/2.7	10	447.1	459.7	12.6	452.7
9	391.7	400	8.3	400	406.8	6.8	400	400	0	403.4	406.8	3.4	406.8	404.3	2.5	8.3/4.2	10	391.7	406.8	15.1	401.9
16	386.9	375	11.9	528.4	521.3	7.1	611.9	605.9	6.0	608.5	606.8	1.7	606.8	606.8	0	11.9/5.3	10	386.9	611.9	225	545.8
17	416.7	414.3	2.4	415.3	416.2	0.9	417	414.3	2.7	417	415.3	1.7	417	420.4	3.4	3.4/2.2	10	414.3	420.4	6.1	416.4
20	425	425	0	421.3	420.4	0.9	419.6	416.2	3.4	415.3	416.2	0.9	416.2	413.6	2.6	3.4/1.6	10	413.6	425	11.4	418.9
21	384.5	391.7	7.2	389.5	392.9	3.4	386.9	386.1	0.8	393.7	393.7	0	392	390.3	1.7	7.2/2.6	10	384.5	393.7	9.2	390.1
22	405.9	404.8	1.1	411.9	413.6	1.7	405.1	408.5	3.4	405.9	410.2	4.3	402.6	406.6	4.0	4.3/2.9	10	402.6	413.6	11	407.5
25	397.6	397.6	0	397.9	400	2.1	400	400	0	397.1	400	2.9	392.9	393.7	0.8	2.9/1.2	10	392.9	400	7.1	397.7
28	385.7	384.5	1.2	367	361.1	5.9	358.5	362.8	4.3	367	367.9	0.9	375	379.3	4.3	5.9/3.3	10	358.5	385.7	27.2	370.9
29	400	400	0	396.3	400	3.7	395.4	396.3	0.9	398	393	5.0	401.7	400	1.7	5.0/2.3	10	393	401.7	8.7	398.1
30	382	366.7	15.3	369.6	375	5.4	364.5	361.9	2.6	365.3	364.5	0.8	368.7	351.7	17	17/8.2	10	351.7	382	30.3	366.9
31	314.3	312.9	1.4	317.9	315.3	2.6	315.3	316.2	0.9	317	317	0	317.9	315.3	2.6	2.6/1.5	10	312.9	317.9	5	315.9
32	325	328.6	3.6	325	325	0	325	325	0	323	323.8	0.8	326.7	325	1.7	3.6/1.2	10	323	328.6	5.6	325.2
33	419	416.7	2.3	417	408.5	8.5	408.5	406.8	1.7	409.4	423.8	14.4	425	423	2	14.9/5.8	10	406.8	425	18.2	415.8
34	332.8	332.1	0.7	408.5	406.8	1.7	410.2	405.1	5.1	386.1	383.5	2.6	386.1	390.3	4.2	5.1/2.9	10	332.1	410.2	78.1	384.2
36	389.3	395.2	5.9	389.5	385.2	4.3	378.4	386.1	7.7	385.2	385.2	0	383.5	386.9	3.4	7.7/4.3	10	378.4	395.2	16.8	386.5
38	383.3	377.4	5.9	375	372.1	2.9	370.4	367.9	2.5	366.2	368.7	2.5	379.3	377.6	1.7	5.9/3.1	10	366.2	383.3	17.1	373.8
39	319	321.4	2.4	322.1	325	2.9	255.1	336.9	81.8	320	334.4	14.4	Noise	328.4	-	81.8/25	10	255.1	336.9	81.8	316.2

TABLE 3-3
BASELINE DATA BEFORE BACKFLUSH CLEANING IN TRIC
FREQUENCY AT +5 PSI

RUN	1	2	Δ	3	4	Δ	5	6	Δ	7	8	Δ	9	10	Δ	MAX Δ/ AVG Δ	# OF RUNS	MIN	MAX	Δ	AVG
S/N																					
4	450	450	0	450	450	0	450	450	0	456.8	450	6.8	443.7	445.4	1.7	6.8/1.7	10	443.7	456.8	13.1	449.6
5	473	467.4	5.6	464.5	468.5	4.0	469.6	471.3	1.7	468.7	463.6	5.1	470.4	469.6	0.8	5.6/3.4	10	463.6	473	10.6	468.7
6	518.9	515.2	3.7	375	-	-	350	348.8	1.2	358.1	355.9	2.2	361.9	360.2	1.7	3.7/2.2	9	348.8	518.9	170.1	393.8
7	518.9	517.4	1.5	514.5	514.5	0	511.9	512.8	0.9	510.2	513.6	3.4	513.6	508.5	5.1	5.1/2.2	10	508.5	518.9	10.4	513.6
9	442.4	453	10.6	456.4	460.5	4.1	451.7	450	1.7	456.8	459.4	2.6	465.3	457.7	7.6	10.6/5.3	10	442.4	465.3	22.9	455.3
16	450	431.9	18.1	617.7	612.1	5.6	-	-	-	710	720	10	715	700	15	18.1/12.2	8	431.9	715	283.1	619.6
17	481.1	478.8	2.3	478.2	476.6	1.6	473.8	470.4	3.4	476.7	476.7	0	475.9	472.1	3.8	3.8/2.2	10	470.4	481.1	10.7	476
20	479.5	481.1	1.6	475	478.2	3.2	471.3	469.6	1.7	467	470.2	3.2	468.7	466.2	2.5	3.2/2.4	10	466.2	481.1	14.9	472.7
21	434.1	450	15.9	442.7	442.7	0	439.5	439.5	0	443.7	446.3	2.6	443.7	442	1.7	15.9/4	10	434.1	450	15.9	442.4
22	464.4	463.6	0.8	467.7	467.7	0	460.2	467	6.8	460.2	460.2	0	457.2	456.8	0.4	6.8/1.6	10	456.8	467.7	10.9	462.5
25	461.3	461.3	0	460.5	462.9	2.4	461.9	457.7	4.2	460.2	461.1	0.9	454.3	455.1	0.8	4.2/1.7	10	454.3	462.9	8.6	459.6
28	441.7	441.7	0	420	414.5	5.5	412.8	410.2	2.6	423	424	1.0	426.7	428.4	1.7	5.5/2.2	10	410.2	441.7	31.5	424.3
29	459.8	463.6	3.8	456.4	457.2	0.8	481.8	478.4	3.4	485.2	482.7	2.5	500	496.3	3.7	3.8/2.8	10	456.4	500	43.6	476.1
30	428.8	421.2	7.6	419.3	417.7	1.6	415.3	415.3	0	417.9	411.9	6	419.6	405.9	13.7	13.7/5.8	10	405.9	428.8	22.9	417.3
31	361.4	355.3	6.1	362.1	359.7	2.4	356.8	356.8	0	361.1	359.4	1.7	360.6	362.8	2.2	6.1/2.6	10	355.3	362.8	7.5	359.6
32	375	381.1	6.1	375	375	0	370.4	368.7	1.7	367	367	0	375	374	1.0	6.1/1.8	10	367	381.1	14.1	372.8
33	477.3	471.2	6.1	474	465.3	8.7	458.5	461.9	3.4	465.3	481.8	16.5	481.8	481.8	0	16.5/6.9	10	458.5	481.8	23.3	471.9
34	379	378.2	0.8	470	466.1	3.9	468.7	467	1.7	443.7	442.7	1.0	436.9	445.4	8.5	8.5/3.2	10	378.2	470	91.8	439.8
36	450	452.3	2.3	442.7	441	1.7	434.4	440	5.6	438.6	442.9	4.3	440.3	442	1.7	5.6/3.1	10	434.4	452.3	17.9	442.4
38	443.2	438.7	4.5	434.7	431.4	3.3	431.8	425	6.8	428.4	423.8	4.6	436.1	432.7	3.4	6.8/4.5	10	423.8	443.2	19.4	432.6
39	365.2	365.2	0	366.1	367.7	1.6	382.7	388.6	5.9	386.9	385.2	1.7	385.2	387.8	2.6	5.9/2.4	10	288.6	388.6	20	370.4

The backflushing method utilizes the environmental chamber, a reservoir with final filter filled with trichloroethylene (TRIC), and air pressure forcing the TRIC in the reverse direction to normal air flow. The backflushing was accomplished three times per unit with the TRIC being captured and filtered through five-micron filter paper. Figure 3-2 presents a sample of the filter paper showing contamination. The numbers on this figure represent the serial number and the backflushing number; i.e., 6-2 is S/N 6 after the second backflushing. After the backflush cleaning, the baseline data was again taken on the 21 units in the same manner as before (ten runs, five setups). This data is presented in Tables 3-4, 3-5 and 3-6. Figure 3-3 compares the frequency spread for the ten runs on each unit before and after the backflushing. This data indicates that the units were extremely contaminated and that backflushing with TRIC significantly improved the performance of the units.

3.3 DATA REDUCTION

The data was recorded on an X-Y plotter. Initial review of the total program indicated that 3228 X-Y plots would be obtained; therefore, the data reduction would be a task in itself.

A typical data plot is shown in Figure 3-4. This plot indicates that the unit is in saturation at approximately ± 10 psi, and has relatively constant slope in the interim. Therefore, three points would determine the slope and would describe the unit's operation. The data could easily be handled by any computer/calculator for any further analysis. The three points that were chosen are the +5, 0 and -5 psi output pressures. For Figure 3-4, the test is a baseline test and the frequency at +5 psi is 455.8 Hz, at 0 psi it is 396.7 Hz, and at -5 psi it is 343.3 Hz. Now that the data is reduced, this can be quickly compared to other tests which have the data reduced and the unit's performance can easily be examined.

3.4 TUNING

After the units had been cleaned by the backflush method, an attempt was made to set all 21 units' performance identical by reaming the tuning orifice. The tuning orifice (see Figure 3-1) is the small hole in the decoupler stack of the FDAC. Varying the size of the hole changes the speed reference in the frequency-to-analog convertor; thus the output of the FDAC can be shifted. Before reaming the tuning orifice, each orifice was measured (see Table 3-7) and the measurement was compared to the set point frequency (+5 psi cross point). The distribution of the unit's frequency before reaming versus the orifice size indicated that the majority of the units could be tuned to a frequency at 400 Hz for +5 psi.

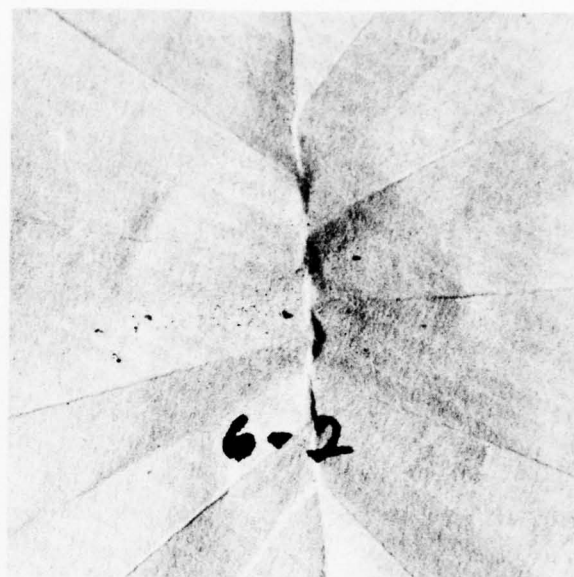
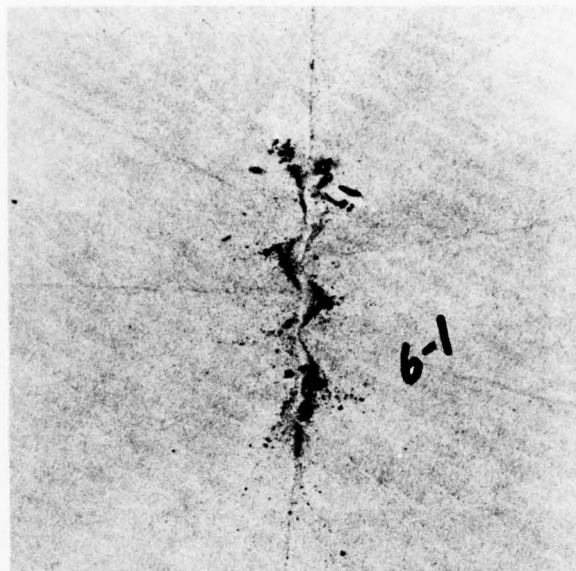

FIGURE 3-2A FILTER PAPER OF S/N 6; RUNS 1,2, AND 3

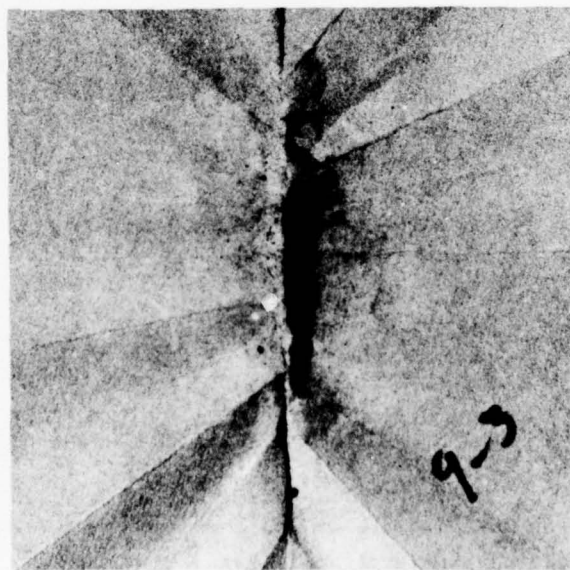
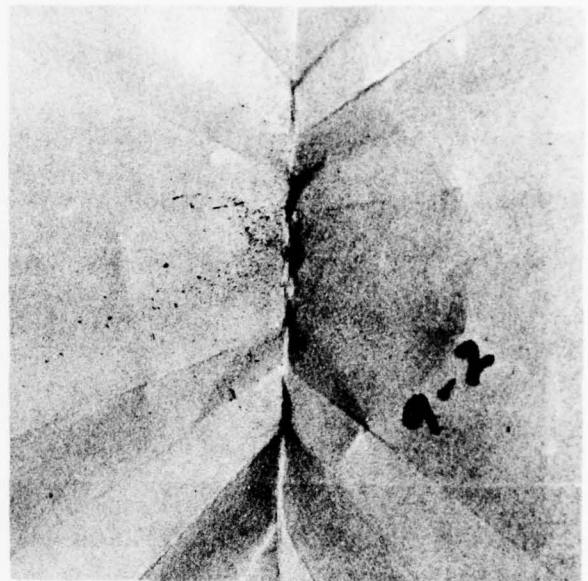
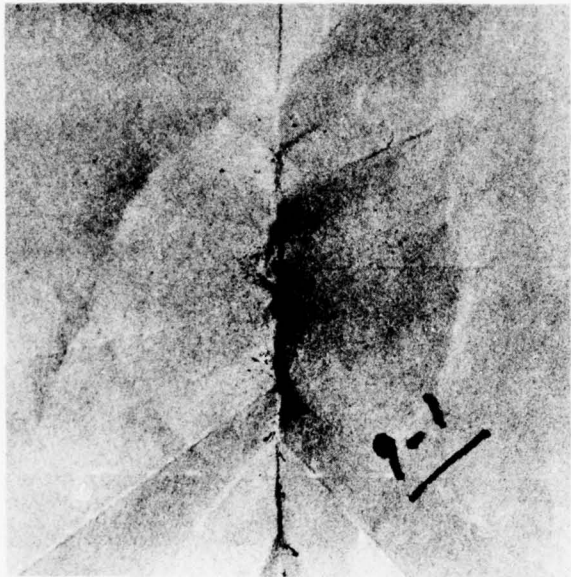

FIGURE 3-2B FILTER PAPER OF S/N 9; RUNS 1,2, AND 3

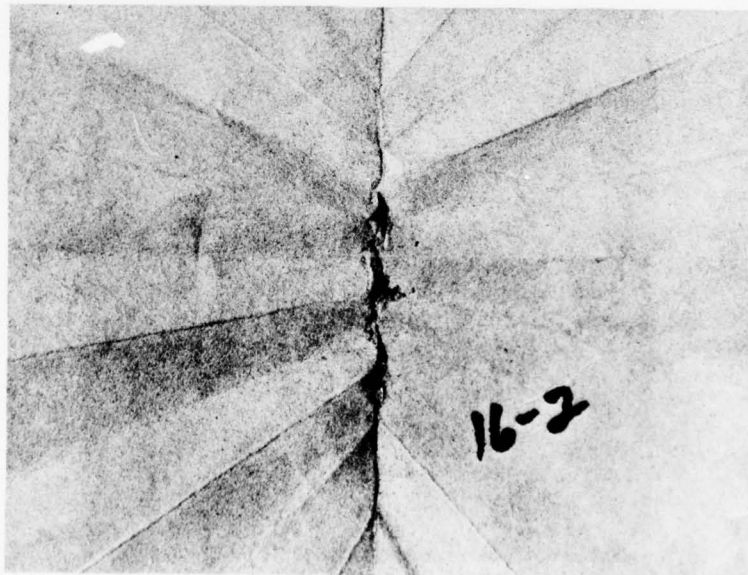
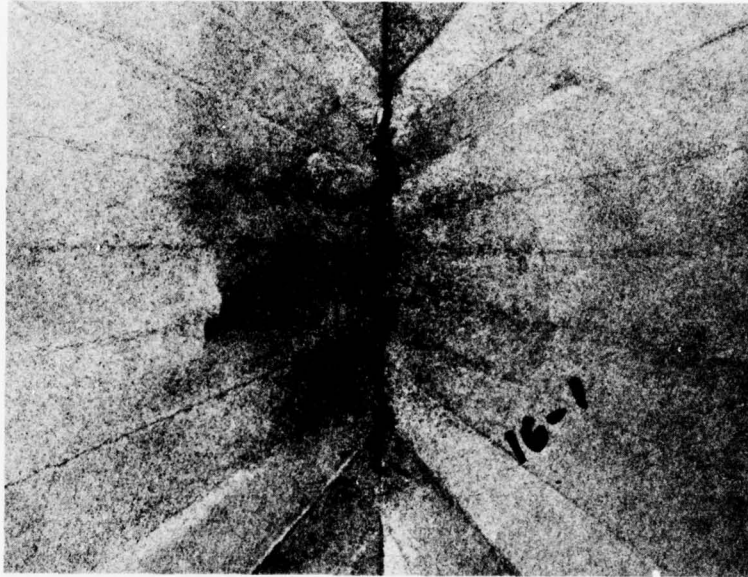

FIGURE 3-2C FILTER PAPER OF S/N 16; RUNS 1 AND 2

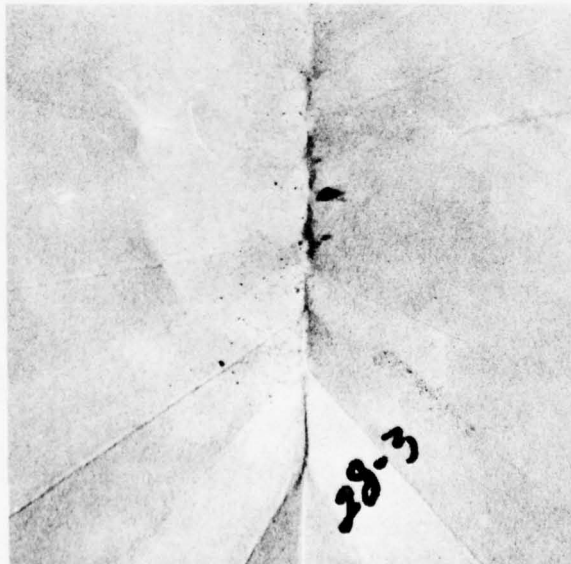
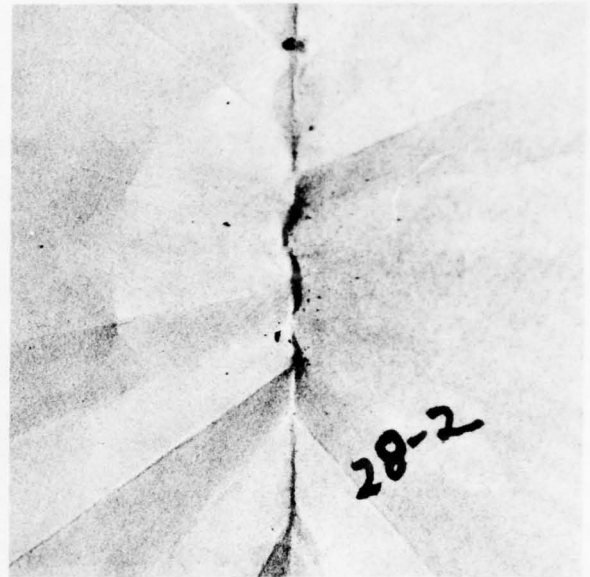
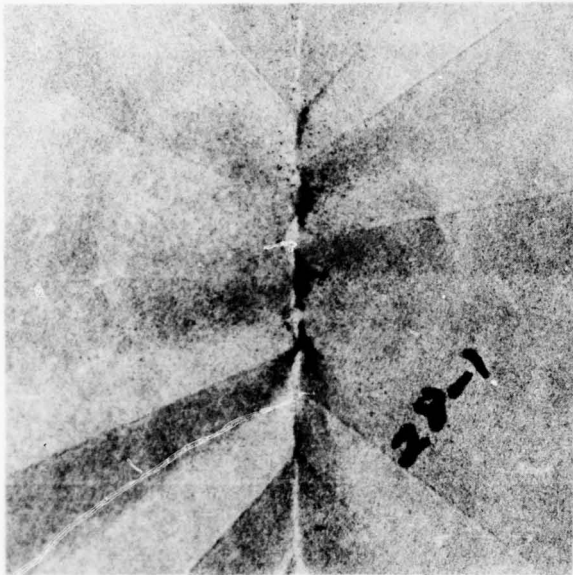

FIGURE 3-2D FILTER PAPER OF S/N 28; RUNS 1,2, AND 3

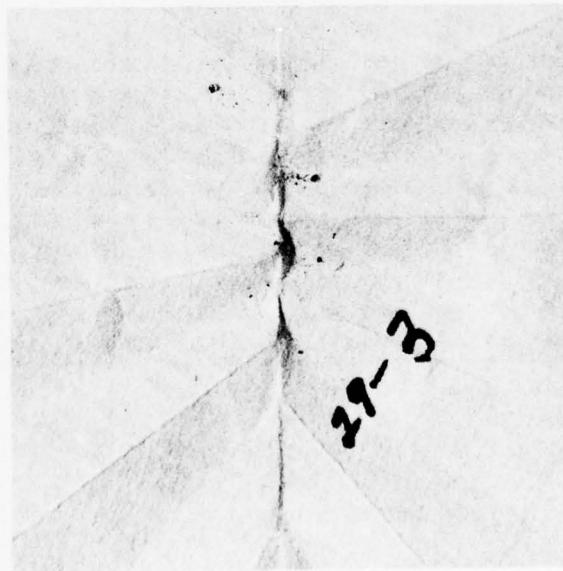
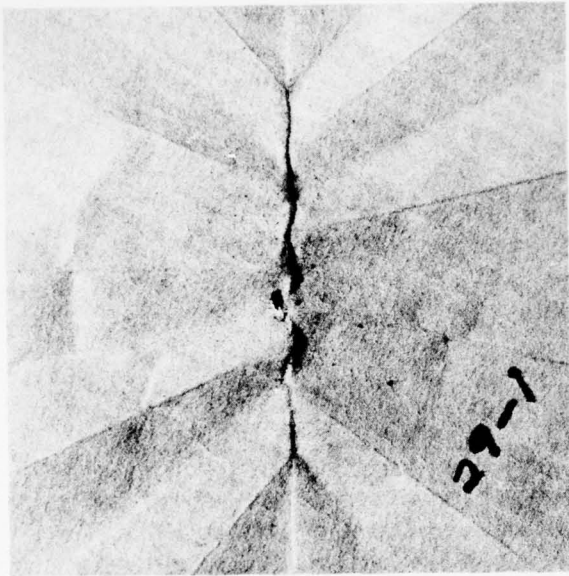

FIGURE 3-2E FILTER PAPER OF S/N 29; RUNS 1,2, AND 3

TABLE 3-4
BASELINE DATA AFTER BACKFLUSH CLEANING IN TRIC
FREQUENCY AT +5 PSI

RUN	1	2	Δ	3	4	Δ	5	6	Δ	7	8	Δ	9	10	Δ	MAX Δ/ AVG Δ	# OF RUNS	MIN	MAX	Δ	AVG
S/N																					
4	454.3	452.3	2	471.3	468.7	2.6	463.6	465.3	1.7	464.5	460.2	4.3	461.1	460.2	0.9	4.3/2.3	10	452.3	471.3	19.0	462.2
5	464.5	460.2	4.3	468.7	472.1	3.4	465.3	467	1.7	465.3	466.2	0.9	475	468.7	6.3	6.3/3.3	10	460.2	475	14.8	467.3
6	481.4	476.7	4.7	478.4	470.4	8	475	474	1	476.7	481.8	5.1	481	480.1	0.9	8.0/3.9	10	470.4	481.8	11.4	477.6
7	517	517.9	0.9	511.1	506.8	4.3	508.5	504.3	4.2	501	500	1	506.8	506.8	0	4.3/2.1	10	500	517.9	17.9	508
9	471.3	470.4	0.9	468.7	465.3	3.4	467	470.4	3.4	469.6	469.6	0	468.7	469.6	0.9	3.4/1.7	10	465.3	471.3	6.0	469.1
16	471.3	472.1	0.8	461.1	465.3	4.2	475	475	0	474	474	0	475	475	0	4.2/1	10	461.1	475	13.9	471.8
17	481.8	475	6.8	479.3	476	3.3	468.7	475	6.3	473	465.3	7.7	474	475	1	7.7/5	10	468.7	481.8	13.1	474.3
20	466.2	463.6	2.6	464.5	464.5	0	464.5	464.5	0	461.9	458.5	3.4	467.9	466.2	1.7	3.4/1.5	10	458.5	467.9	9.4	464.2
21	450	462.8	12.8	454.3	456	1.7	447.1	454.3	7.2	454.3	454.3	0	452.6	448	4.6	12.8/5.3	10	447.1	462.8	15.7	453.4
22	453.4	462.8	9.4	457.7	454.3	3.4	460.2	461.9	1.7	460.2	455.1	5.1	458.5	454.7	3.8	9.4/4.4	10	453.4	462.8	9.4	457.9
25	481.8	481.8	0	477.6	476.7	0.9	459.4	465.3	5.9	457.7	460.2	2.5	469.6	468.7	0.9	5.9/2	10	457.7	481.8	24.1	469.9
28	469.6	479.7	10.1	469.1	473.8	4.7	475	470.4	4.6	475	471.3	3.7	481	480.1	0.9	10.1/4.8	10	469.6	481	11.4	474.5
29	415.3	425	9.7	423.8	429.3	5.5	423	425	2	418.7	417	1.7	414	413.6	0.4	9.7/3.9	10	413.6	429.3	15.7	420.5
30	436.9	440.3	3.4	430.1	431	0.9	426.7	435.2	8.5	431.8	431.8	0	426.7	429.3	2.6	8.5/3.1	10	426.7	440.3	13.6	432
31	421.3	425	3.7	415.7	417.9	2.2	410.2	410.2	0	405.1	401.7	3.4	405.1	400	5.1	5.1/2.9	10	400	425	25	411.2
32	450	448.8	1.2	447.1	442	5.1	450	453.4	3.4	451.7	455.1	3.4	450	456	6.0	6.0/3.8	10	442	456	14	450.4
33	423.8	425	1.2	430.1	436.1	6	442	450	8.0	450	447.1	2.9	459.4	456.8	2.6	8.0/4.1	10	423.8	459.4	35.6	442
34	469.6	465.3	4.3	467	469.6	2.6	473	475	2	464.5	467	2.5	471.3	475	3.7	3.7/2.8	10	464.5	475	10.5	469.7
36	450	451.7	1.7	450	446.3	3.7	439.9	449	9.1	450	447.1	2.9	446.3	443.7	2.6	9.1/4	10	439.9	451.7	11.8	447.4
38	428.4	422.5	5.9	421.3	428.4	7.1	436.1	431.8	4.3	431.8	425	6.8	439.5	425	14.5	14.5/7.7	10	421.3	439.5	18.2	429
39	451.7	452.6	0.9	455.1	455.1	0	457.7	456.8	0.9	458.5	456.8	1.7	456	457.7	1.7	1.7/1.0	10	451.7	458.5	6.8	455.8

TABLE 3-5
BASELINE DATA AFTER BACKFLUSH CLEANING IN TRIC
FREQUENCY AT -5 PSI

RUN	1	2	Δ	3	4	Δ	5	6	Δ	7	8	Δ	9	10	Δ	MAX Δ/ AVG Δ	# OF RUNS	MIN	MAX	Δ	AVG
S/N																					
4	350	351.7	1.7	361.9	362.8	0.9	361.1	361.9	0.8	359.4	356	3.4	359.4	358.9	0.5	3.4/1.5	10	350	362.8	12.8	358.3
5	356.8	356.8	0	365.3	368.7	3.4	365.3	365.3	0	361.1	362.8	1.7	369.6	365.3	4.3	4.3/1.9	10	356.8	369.6	12.8	363.7
6	369.6	364.5	5.1	365.3	361.9	3.4	363.6	364.5	0.9	367	371.3	4.3	370.4	368.7	1.7	5.1/3.1	10	361.9	371.3	9.4	366.7
7	403.4	400	3.4	398	393.7	4.3	395.4	392	3.4	391.2	386.9	4.3	389.5	389.5	0	4.3/3.1	10	386.9	403.4	16.5	394
9	358.5	361.9	3.4	357.7	360.2	2.5	360.2	360.2	0	360.2	362.8	2.6	360.2	361.9	1.7	2.6/1.8	10	357.7	362.8	5.1	360.4
16	355.1	355.9	0.8	348	352.6	4.6	360.2	358.5	1.7	356.8	356.8	0	363.6	360.2	3.4	4.6/2.1	10	348	363.6	15.6	356.8
17	357.7	359.4	1.7	361.1	363.6	2.5	359.4	360.2	0.8	361.1	359.4	1.7	360.2	361.1	0.9	2.5/1.5	10	357.7	363.6	5.9	360.3
20	361.1	361.9	0.8	361.1	359.4	1.7	362.8	365.3	2.5	362.8	361.9	0.9	361.9	363.6	1.7	2.5/1.5	10	359.4	365.3	5.9	362.2
21	340.3	348	7.7	344.6	344.1	0.5	339.5	342	2.5	341.2	342	0.8	340.3	340.3	0	7.7/2.3	10	339.5	348	8.5	342
22	343.7	356	12.3	350	348	2	352.6	351.7	0.9	356	350	6.0	356	352.6	3.4	12.3/4.9	10	343.7	356	12.3	351.7
25	365.3	368.7	3.4	365.3	361.1	4.2	350	353.4	3.4	350	350	0	356	357.7	1.7	4.2/2.5	10	350	368.7	18.7	357.8
28	351.7	366.2	14.5	361.1	364.5	3.4	366.2	362.8	3.4	361.1	361.1	0	367	368.7	1.7	14.5/4.6	10	351.7	368.7	17	363
29	317	325	8	324	330	6	325	326.7	1.7	326.7	322.1	4.6	324	324	0	8.0/4.1	10	317	330	13	324.5
30	324	331	7	323.8	324	0.2	325	328.4	3.4	328.4	331	2.6	326.7	330.1	3.4	7.0/3.3	10	323.8	331	7.2	327.2
31	317.9	317.9	0	316.2	313.6	2.6	311.1	312.8	1.7	308.5	306.5	2.0	305.1	307.7	2.6	2.6/1.8	10	305	317.9	12.9	311.7
32	342	340.3	1.7	336.1	337.8	1.7	342	350	8	348.8	350	1.2	344.6	348	3.4	8.0/3.2	10	336.1	350	13.9	344
33	331.8	335.2	3.4	340.3	342	1.7	350	352.6	2.6	348	350	2.0	360.2	351.7	8.5	8.5/3.6	10	331.8	360.2	28.4	346.2
34	354.3	354.3	0	356.8	356.8	0	364.5	362.8	1.7	357.7	362.8	5.1	363.6	367	3.4	5.1/2	10	354.3	367	12.7	360.1
36	336.1	343.7	7.6	341.2	338.6	2.6	338.6	343.7	5.1	342.9	341.2	1.7	340.3	340.3	0	7.6/3.4	10	336.1	343.7	7.6	340.7
38	328.4	323.8	4.6	323.8	324	0.2	331	329.3	1.7	330.1	324	6.1	327.6	329.3	1.7	6.1/2.9	10	323.8	331	7.2	327.1
39	332.7	332.7	0	331.8	333.5	1.7	340.3	340.3	0	341.2	337.8	3.4	338.6	339.5	0.9	3.4/1.2	10	331.8	341.2	9.4	336.8

TABLE 3-6
BASELINE DATA AFTER BACKFLUSH CLEANING IN TRIC
FREQUENCY AT 0 PSI

RUN	1	2	Δ	3	4	Δ	5	6	Δ	7	8	Δ	9	10	Δ	MAX Δ/ AVG Δ	# OF RUNS	MIN	MAX	Δ	AVG
S/N																					
4	400	393.7	6.3	412.8	411.9	0.9	408.5	410.2	1.7	404.5	402.6	1.9	406.8	406.8	0	6.3/2.2	10	393.7	412.8	19.1	405.8
5	406.8	405.9	0.9	412.8	415.3	2.5	411.9	414.5	2.6	410.2	413.2	3.0	417	411.7	5.3	5.3/2.9	10	405.9	417	11.1	411.9
6	426	418.7	7.3	420.3	415.3	5	417.7	417	0.7	419.6	422.9	3.3	425	420.4	4.6	7.3/4.2	10	415.3	426	10.7	420.3
7	458.1	456.8	1.3	450	450	0	446.3	448.5	2.2	444.6	440.3	4.3	442	443.7	1.7	4.3/1.9	10	440.3	458.1	17.8	448
9	408.5	417	8.5	411.9	414	2.1	410.6	413.6	3	414.5	414.5	0	412.8	411.9	0.9	8.5/2.9	10	408.5	417	8.5	412.9
16	408.5	411.1	2.6	401.7	405.5	3.8	413.6	413.6	0	411.9	411.1	0.8	415.3	415.3	0	3.8/1.4	10	401.7	415.3	13.6	410.8
17	412.8	415.3	2.5	415.3	415.3	0	406	410.2	4.2	411.1	406.8	4.3	411.1	415.3	4.2	4.3/2.96	10	406	415.3	9.3	411.9
20	410.2	409.4	0.8	410.2	408.9	1.3	408.5	411.1	2.6	406.8	407.7	0.9	412.8	408.1	4.7	4.7/2.1	10	406.8	412.8	6	409.4
21	390.3	405.1	14.8	393.7	393.7	0	388.6	392	3.4	390.3	393.7	3.4	390.3	389.5	0.8	14.8/4.5	10	388.6	405.1	16.5	392.7
22	393.7	406.8	13.1	404.3	400	4.3	401.7	403.4	1.7	405.1	400	5.1	404.7	398	6.7	13.1/6.2	10	393.7	406.8	13.1	401.8
25	420.4	421.3	0.9	414	417	3	400	403.4	3.4	400	400	0	407.7	408.5	0.8	3.4/1.6	10	400	421.3	21.3	409.2
28	406.8	417.9	11.1	412.8	412.8	0	417	415.3	1.7	411.9	412.8	0.9	418.7	419.6	0.9	11.1/2.9	10	406.8	419.6	12.8	414.6
29	361.1	371.3	10.2	371.3	372.1	0.8	370.4	371.3	0.9	367.9	364	3.9	362.8	363.2	0.4	10.2/3.2	10	361.1	372.1	11	367.5
30	377.6	383.5	5.9	373.3	379.3	6.0	375	379.3	4.3	378.4	373.8	4.6	373	376.7	3.7	6.0/4.9	10	373	383.5	10.5	377
31	362.8	369.1	6.3	361.9	364.5	2.6	360.2	356.8	3.4	351.7	350	1.7	348	350	2.0	6.3/3.2	10	348	369.1	21.1	357.5
32	390.3	392	1.7	391.2	389.5	1.7	392	399	7.0	396.3	396.3	0	399	399	0	7.0/2.1	10	390.3	399	8.7	394.5
33	376.7	378.4	1.7	383.5	386.1	2.6	393.7	400	6.3	391.2	393.7	2.5	408.5	400	8.5	8.5/4.3	10	376.7	408.5	31.8	391.2
34	404.3	404.3	0	408.5	408.5	0	414.5	415.3	0.8	406.8	410.2	3.4	411.5	415.3	3.8	3.8/1.6	10	404.3	415.3	11	409.9
36	392	392	0	387.8	390.3	2.5	390.3	390.3	0	392	389.5	2.5	388.6	389.5	0.9	2.5/1.2	10	387.8	392	4.2	390.2
38	376.7	368.7	8.0	366.2	374	7.8	376.7	377.6	0.9	376	375	1.0	375	376	1.0	8.0/3.7	10	366.2	377.6	11.4	374.2
39	391.2	390.3	0.9	390.3	389.5	0.8	393.7	392	1.7	403.4	394.6	8.8	392.9	392.9	0	8.8/2.4	10	389.5	403.4	13.9	393.1

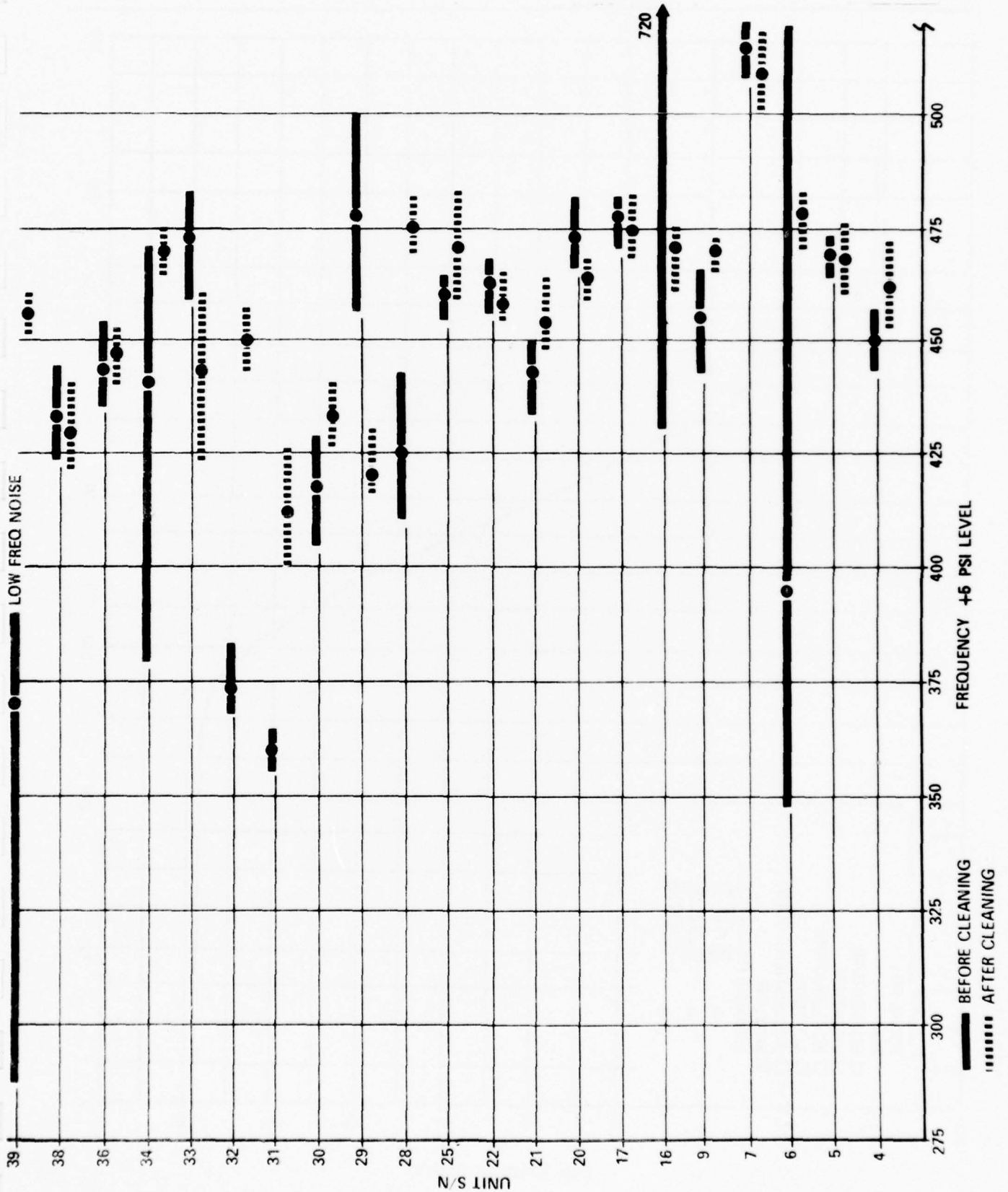

FIGURE 3-3 DATA COMPARISON OF FLUIDIC FUZES BEFORE AND AFTER CLEANING

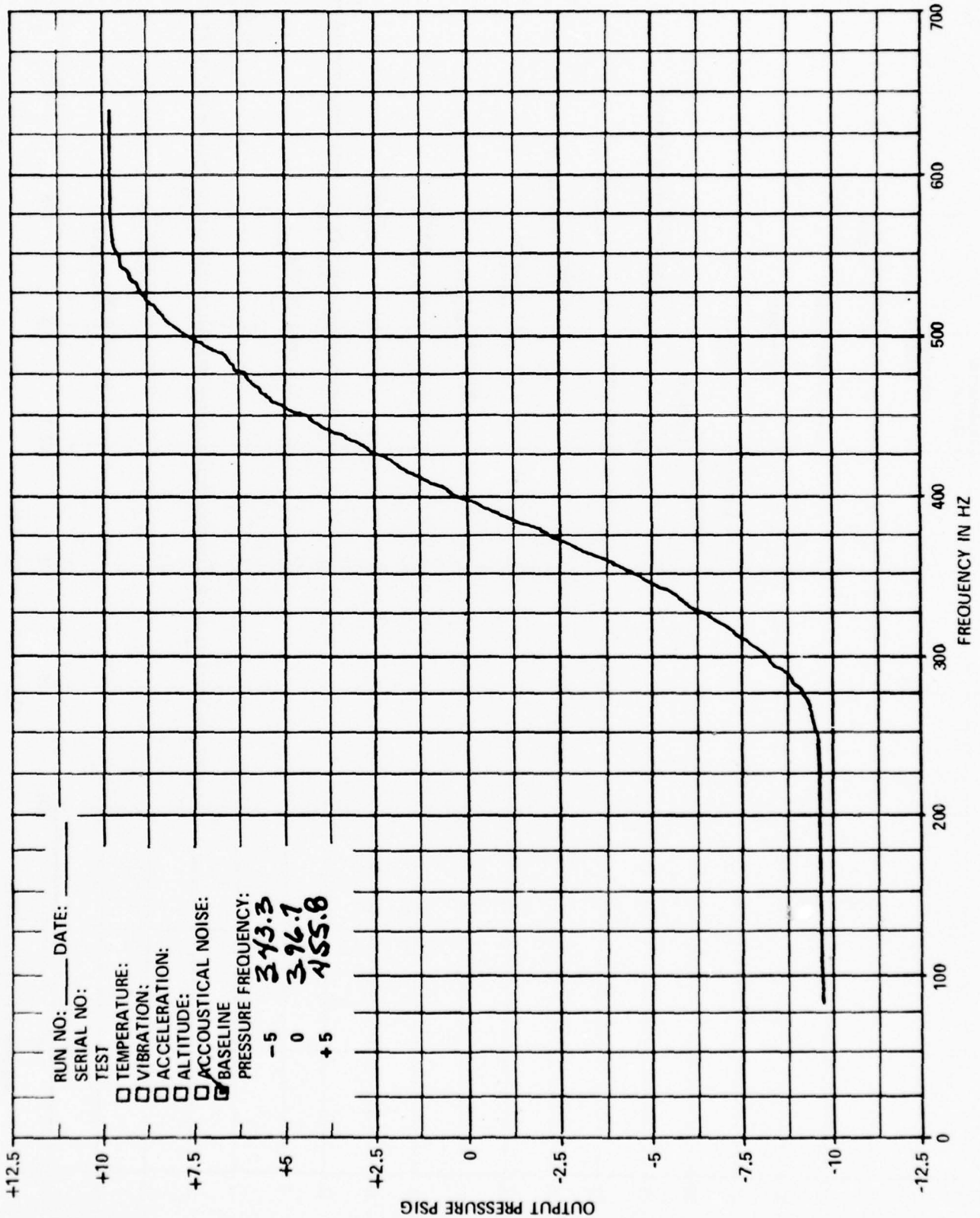

FIGURE 3-4 TYPICAL FLUIDIC FUZE TRANSFER FUNCTION

TABLE 3-7
ORIFICE VALUE

<u>Serial/Number</u>	<u>Before Tuning</u>	<u>After Tuning</u>	<u>Difference</u>
4	.02135 inches	.0280	.00665
5	.02245	.0262	.00375
6	.02145	.0291	.00765
7	.0207	.0299	.0092
9	.02275	.0256	.00285
16	.0276	.0295	.0019
17	.0232	.0279	.0047
20	.0221	.0292	.0071
21	.024	.0257	.0017
22	.0245	.0275	.003
25	.0237	.0268	.0031
28	.02425	.0291	.0049
29	.0237	.0276	.0039
30	.0242	.0258	.0016
31	.0249	.0263	.0014
32	.0248	.0295	.0047
33	.02	.0255	.0055
34	.0225	.0261	.0036
36	.02765	.0279	.0003
38	.0262	.0267	.0005
39	.0251	.0281	.003

After reaming and tuning the units, the fuzes were performance tested, backflush cleaned, and again performance tested (see Table 3-8 and Figure 3-5 for results).

The data in Figure 3-5 indicates:

- 32% of the 84 baseline runs are within ± 5 Hz of 400 Hz at 5 psi
- 56% of the 84 baseline runs are within ± 10 Hz of 400 Hz at 5 psi
- 76% of the 84 baseline runs are within ± 15 Hz of 400 Hz at 5 psi
- 83.3% of the 84 baseline runs are within ± 20 Hz of 400 Hz at 5 psi
- 89% of the 84 baseline runs are within ± 25 Hz of 400 Hz at 5 psi
- 94% of the 84 baseline runs are within ± 30 Hz of 400 Hz at 5 psi

Figure 3-30 \diamond indicates baseline runs after reaming prior to backflush cleaning.

Figure 3-30 ∇ indicates baseline runs after reaming and backflush cleaning.

After the tuning and performance test, the units were installed in the environmental chambers and again tuned. The units' setpoint frequency was intended to be 400 Hz. When the unit was installed in the chamber and the chamber orifice reamed, it was impossible to maintain the 400-Hz setpoint and also maintain sonic conditions across the orifice. Since the purpose of the chamber was to provide altitude isolation through maintaining a critical pressure ratio, this was the more important parameter. It was therefore decided to select another setpoint which would allow sonic operation. Thus, 500 Hz was selected and all chambers were tuned. This data is exhibited in Table 3-9 and Figure 3-6. This data shows the distribution at -5 psi to be 321-395, at 0 psi 400-454 and at +5 psi 470-518. This data was obtained from 20 units and 60 runs with three runs per unit. Unit S/N 21 stopped functioning entirely. Cleaning and backflushing failed to revive the unit.

3.5 SUPPLY PRESSURE VARIATION

The purpose of this test was to evaluate the FDAC performance when subjected to varying supply pressure. The units were set up in the normal manner within their chambers and the supply pressure was varied ± 8 psi about the design pressure of 40 psig in 2 psi increments. Two runs were made on each serial number unit at each pressure. Table 3-10 presents a summary tabulation of the reduced data for unit S/N 17. These data are plotted in Figure 3-7 and show that the frequency response follows a linear relation to supply pressure.

3.6 STEP PULSE INPUT RESPONSE

The purpose of this test was to investigate the response of the FDAC to a step change in input frequency. The test setup was as described in section 2.4. Figure 3-8 is a sample curve of the output data of this test. The maximum pressure excursion before stabilization was 11.2 psi. Stabilization occurred in 3.5 s. Each FDAC received two additional step pulse runs at 500 Hz set frequency. In addition, each FDAC was subjected to three step pulse tests at set frequencies of 200, 400 and 600 Hz for a total of 13 step pulse tests.

TABLE 3-8
BASELINE DATA AT +5 PSI AFTER REAMING AND CLEANING

RUN S/N	Δ				Δ 3 & 4	Δ between Run and 400 Hz				Note: Runs 1 & 2 after reaming before cleaning. Runs 3 & 4 after reaming, after cleaning.
	1	2	1 & 2	3		4	1	2	3	
4	388	393.7	5.7	398	395.4	-12	-6.3	-2	-4.6	Minus indicates run less than 400 Hz. Plus indicates run more than 400 Hz.
5	393.7	385.2	8.5	382	385.2	-6.3	-14.8	-18	-14.8	
6	397.1	400	2.9	388.6	387	-2.9	0	-11.4	-13	
7	400	402	2	402	403.4	0	+2	+2	3.4	
9	408.5	406.8	1.7	408.5	403.4	8.5	6.8	8.5	3.4	
16	338.6	333.5	5.1	335.2	340.3	-61.4	-66.5	-64.8	-59.5	
17	380.1	383.5	3.4	390.3	390.3	-19.9	-16.5	-9.7	-9.7	
20	392	393.7	1.7	400	393.7	-8	-6.3	0	-6.3	
21	405.1	406.8	1.7	412	407	5.1	6.8	12	7	
22	392	393.7	1.7	410.2	408.5	-8	-6.3	10.2	8.5	
25	372	375	3.0	400	375	-28	-25	0	-25	
28	388.6	385.2	3.4	393.7	393.7	-11.4	-14.8	-6.3	-6.3	
29	401	400	1	415.3	415.3	1	0	15.3	15.3	
30	400	402	2	405.1	406.8	0	2	5.1	6.8	
31	372.1	377	4.9	367	380	-27.9	-23	-33	-20	
32	400	395.4	4.6	387	388.6	0	-4.6	-13	-11.3	
33	393.7	393.7	0	412	407	-6.3	-6.3	12	7	
34	400	401	1	430.1	430.1	0	1	30.1	30.1	
36	393.7	388.3	5.4	425	426.7	-6.3	-11.7	25	26.7	
38	401	400	1	417	413.6	+1	0	17	13.6	
39	395.4	400	4.6	390.3	387	-4.6	0	-4.7	-13	

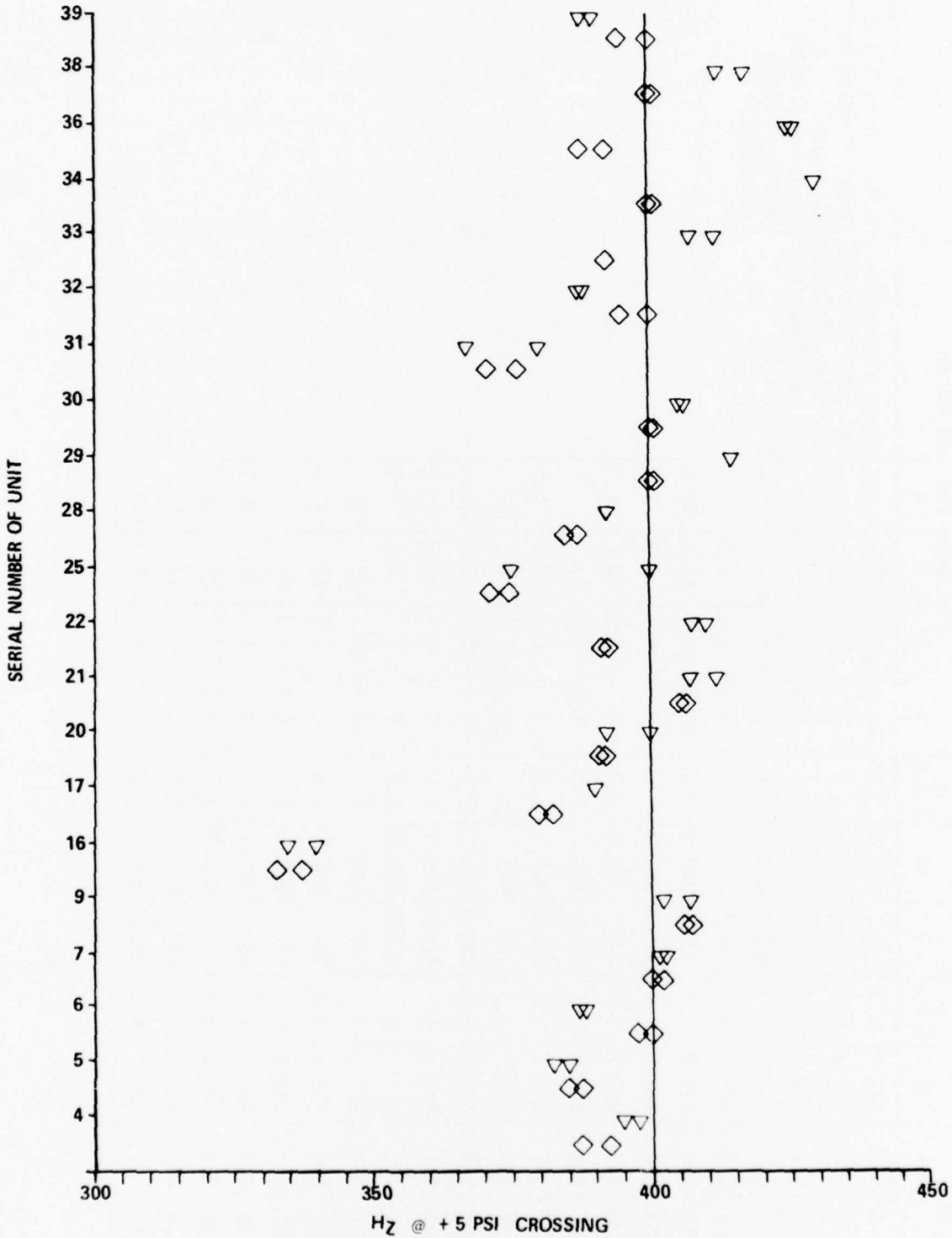

FIGURE 3-5 FLUIDIC FREQUENCY DISTRIBUTION AFTER TUNING, FDAC ONLY

TABLE 3-9
BASELINE DATA AFTER CHAMBER TUNING

S/N	-5 psi				0 psi				+5 psi			
	Run No.				Run No.				Run No.			
	1	2	3	Avg.	1	2	3	Avg.	1	2	3	Avg.
4	384.2	381.7	379.2	381.7	444.2	439.2	435	439.5	505.8	510.8	504.2	506.9
5	389.2	395	391.7	392.0	439.2	446.7	454.2	446.7	500	504.2	518	507.4
6	375	368.3	369.2	370.8	435	421.7	425	427.2	505	490	486.7	493.3
7	369.2	373.3	363.3	368.6	423.3	430	423.3	425.5	489.2	491.7	491.7	490.9
9	369.2	369.2	350.8	366.4	425	429.2	425	426.4	492.5	500	504.2	498.9
16	330.8	335	340	345.3	400	408.3	415.8	408.0	470	485	493.3	482.8
17	375	375	375	375	443.3	438.3	436.7	439.4	518.3	513.3	506.7	512.8
20	380	375	370.8	375.3	435	437.5	428.3	433.6	501.7	506.7	505.8	504.7
21	-	-	-	-	-	-	-	-	-	-	-	-
22	359.2	359.2	360	359.5	422.5	423.3	420.8	422.2	491.7	492.5	484.2	489.5
25	365	360.8	357.5	361.1	425	430.8	422.5	426.1	492.5	505	497.5	498.3
28	375	374	363.3	370.8	441.7	438.3	425	435.0	510.8	506.7	490.8	502.8
29	372.5	367.5	366.7	368.9	440	431.7	423.3	431.7	512.5	506.7	492.5	503.9
30	356.7	349	350	351.9	428.3	418.3	416.6	421.1	500	494.2	490	494.7
31	367.5	368.3	368.3	368	426	425	430	427.0	490	490	493.3	491.1
32	343.3	350	351	348.1	413.3	425	423.3	420.5	476	489.2	489.2	484.8
33	323.3	322.5	325	323.6	404.2	400	407.5	403.9	481.7	482.5	486.7	483.6
34	355	350	351.7	352.2	415	412.5	411.7	413.1	481.7	482.9	482.5	482.4
36	365	360	366.7	363.9	425	420.8	431.7	425.8	495	487.5	496.7	493.1
38	343.3	343.3	346.7	344.4	406.7	405.8	412.5	408.3	480.8	472.8	485	479.5
39	330	337.5	340	335.8	408.3	412.5	416.7	412.5	485	491.7	487.5	488.1

ENVIRONMENTAL TESTING
 OF A FLUIDIC DIGITAL-TO-ANALOG
 CONVERTER

SERIAL NUMBER	FREQUENCY DEVIATION AT -5 PSI AVG 360.7 MIN 322.5, MAX 395	FREQUENCY DEVIATION AT 0 PSI AVG 424.7 MIN 400, MAX 454.2	FREQUENCY DEVIATION AT +5 PSI AVG 494.5 MIN 470, MAX 518.3
39-3	•	•	•
39-2	•	•	•
39-1	•	•	•
38-3	•	•	•
38-2	•	•	•
38-1	•	•	•
36-3	•	•	•
36-2	•	•	•
36-1	•	•	•
34-3	•	•	•
34-2	•	•	•
34-1	•	•	•
33-3	•	•	•
33-2	•	•	•
33-1	•	•	•
32-3	•	•	•
32-2	•	•	•
32-1	•	•	•
31-3	•	•	•
31-2	•	•	•
31-1	•	•	•
30-3	•	•	•
30-2	•	•	•
30-1	•	•	•
29-3	•	•	•
29-2	•	•	•
29-1	•	•	•
28-3	•	•	•
28-2	•	•	•
28-1	•	•	•
25-3	•	•	•
25-2	•	•	•
25-1	•	•	•
22-3	•	•	•
22-2	•	•	•
22-1	•	•	•

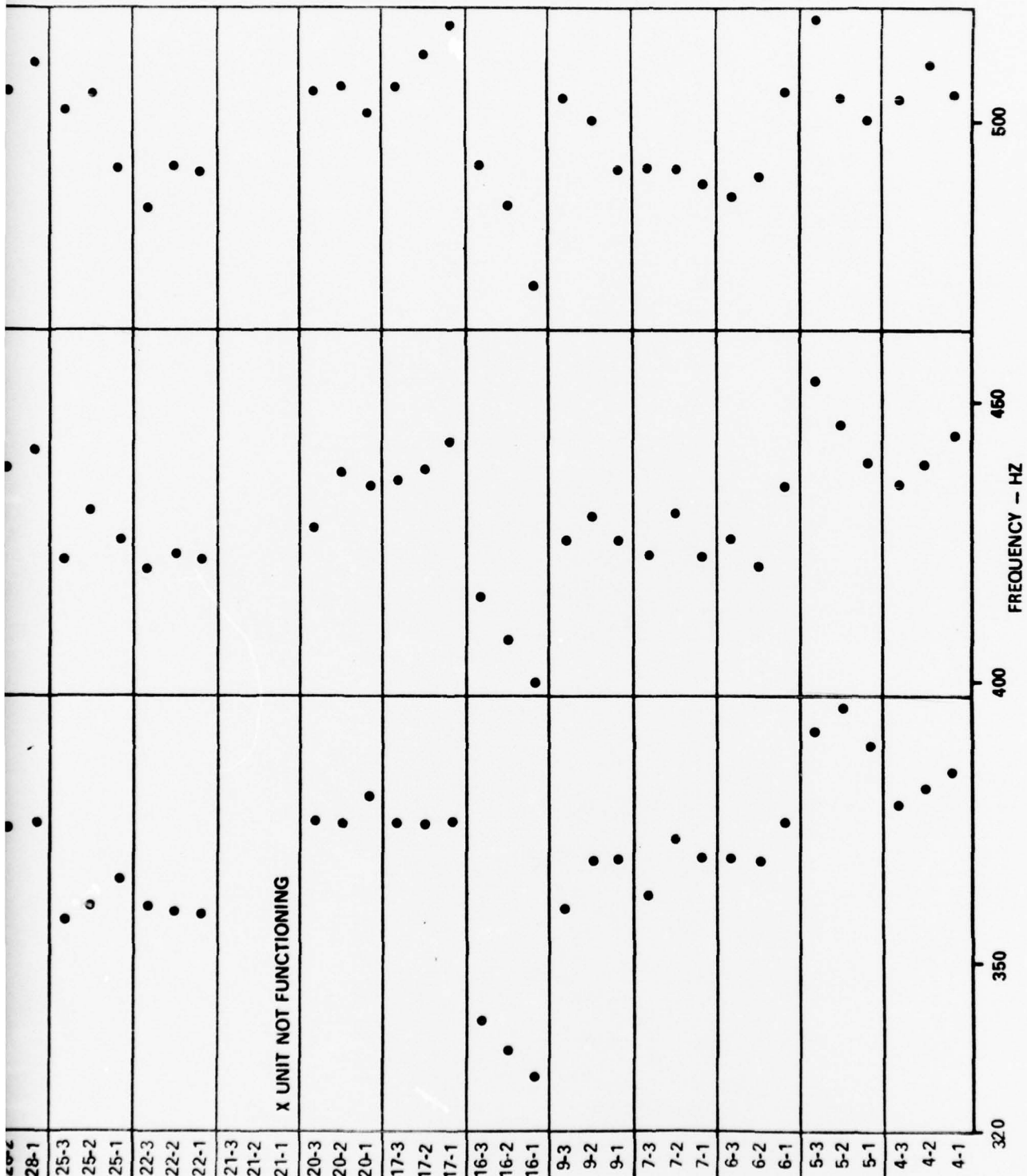

FIGURE 3-6 RESULTS OF ENVIRONMENTAL CHAMBER TUNING

TABLE 3-10
 EFFECT OF CHANGING SUPPLY PRESSURE
 S/N 17

P_s	-5	Avg.	0	Avg.	+5	Avg.
32	325	322.1	391.7	389.2	460	459.2
32	319.2		386.7		458.3	
34	330.8	332.9	394.2	400	460.8	463.8
34	335		405.8		466.7	
36	351.7	346.7	414.2	412.1	483.3	479.2
36	341.7		410		475	
38	356.7	356.7	422.5	422.9	490.8	488.8
38	356.7		423.3		486.7	
40	370	369.2	433.3	431.7	500	500.9
40	368.3		430		501.7	
42	384.2	382.5	443.3	441.7	515	512.5
42	380.8		440		510	
44	390	389.2	452.5	451.3	516.7	515.9
44	388.3		450		515	
46	407.5	406.7	466.7	466.3	533.3	535.4
46	405.8		465.8		537.5	
48	424	422.4	485	483.8	550	547.9
48	420.8		482.5		545.8	

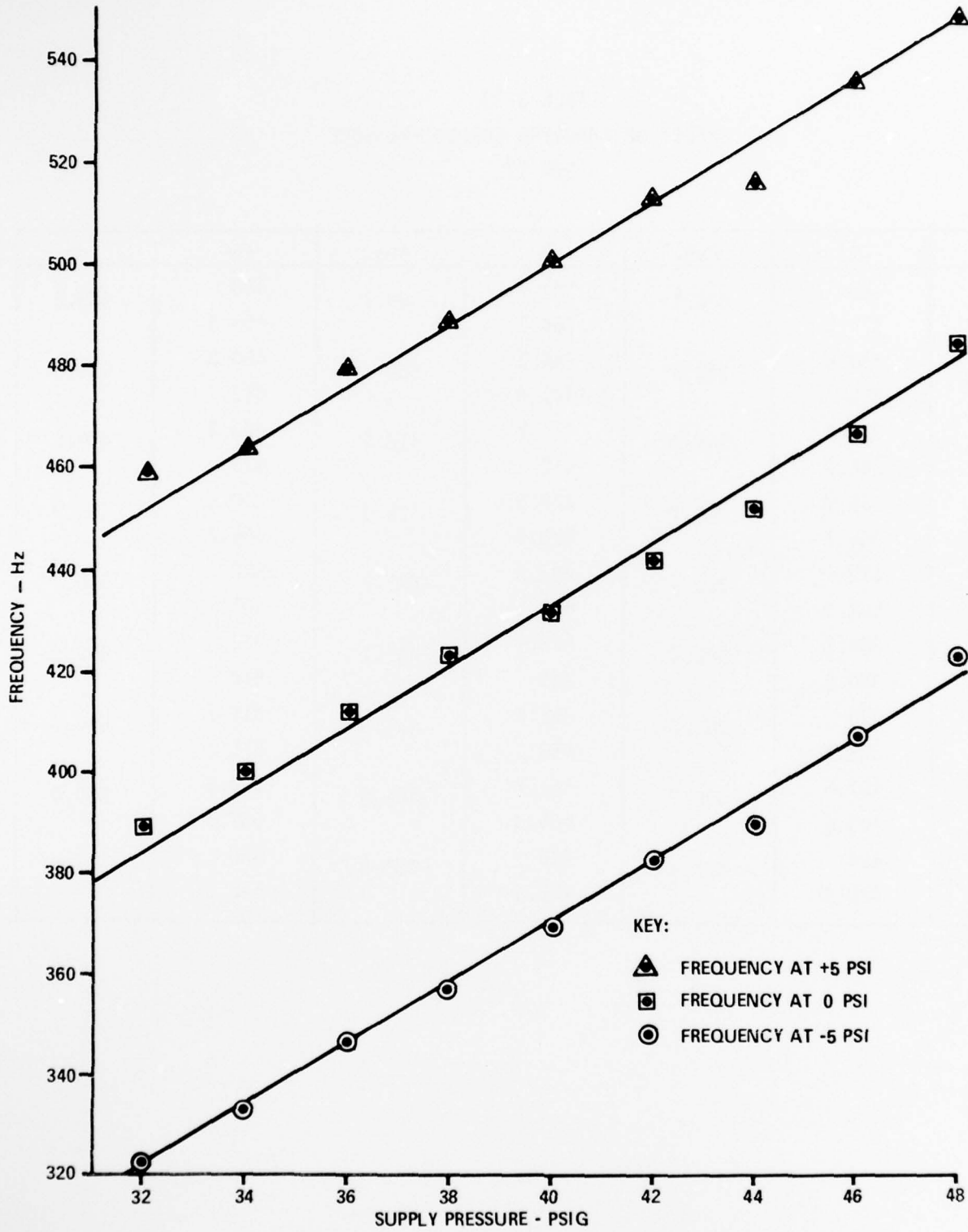

FIGURE 3-7 EFFECT OF SUPPLY PRESSURE VARIATION

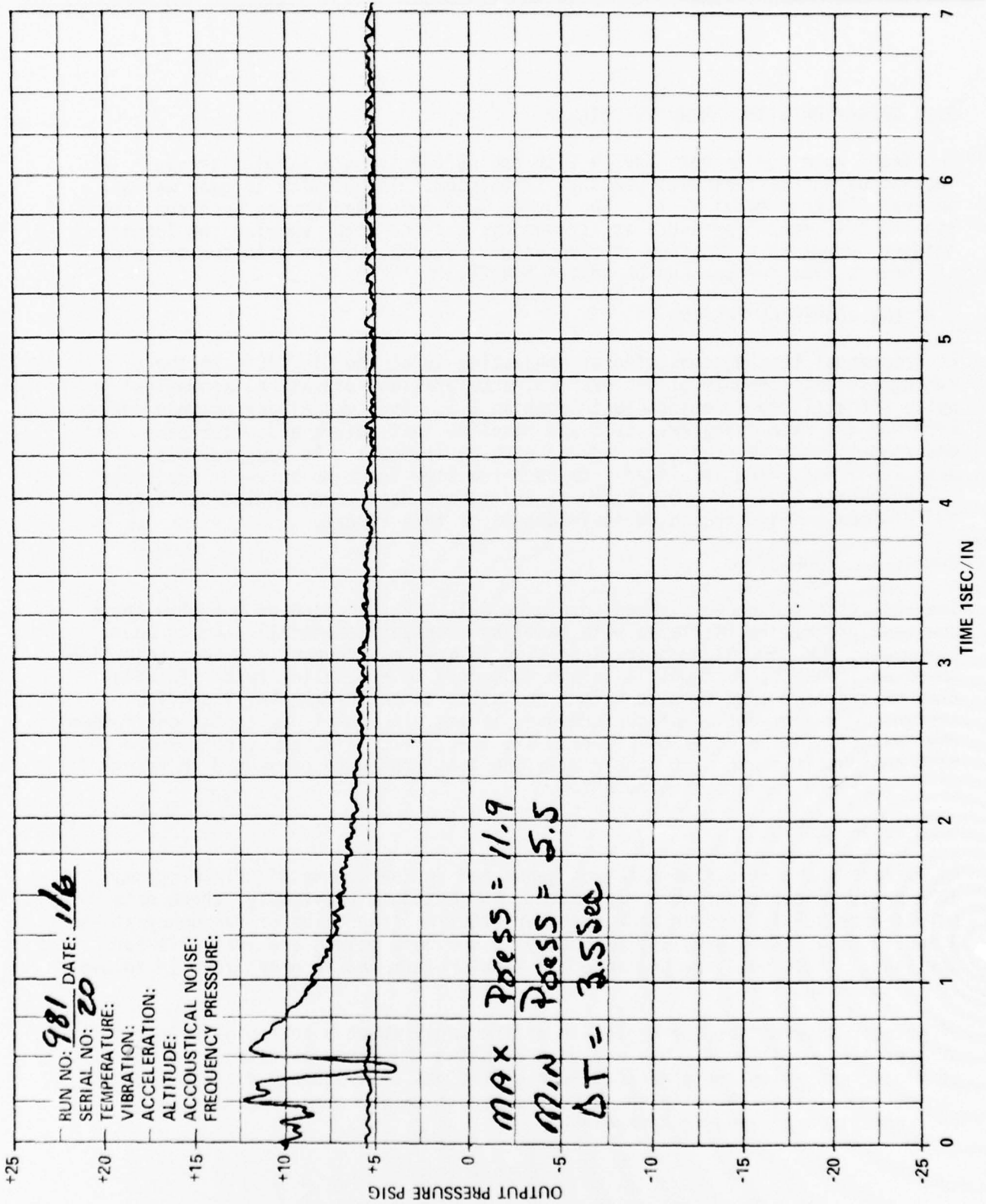

FIGURE 3-8 FDAC RESPONSE TO STEP INPUT

3.7 OPERATION WITH A SCHMITT TRIGGER

Two tests were run on each device with the FDAC driving a Schmitt trigger instead of the differential pressure transducer. The Schmitt trigger was a General Electric Model MT 11. Two curves were generated during each run, one showing FDAC output pressure vs. frequency, and the other showing the Schmitt trigger output as a function of frequency. Figures 3-9 and 3-10 are examples of these curves for one run on device S/N 20.

3.8 ENVIRONMENTAL TESTING

Environmental testing consisted of subjecting 19 of the 21 FDAC's to the overstress environments of temperature, acceleration, vibration, acoustical noise and altitude as described in section 2.5. The typical performance curves were run for each overstress test and baseline test before and after each environment. Three runs were made at each environment. As was previously discussed, data were tabulated from each transfer function curve of frequency corresponding to -5 psi, 0 psi and +5 psi. These data were tabulated, averaged and plotted and are presented in Volume II of this report.

3.9 TEST SEQUENCE

The FDAC test sequence is shown in Figure 3-11. Examination of the plan shows the test program is initiated with baseline (non-environmental) testing and all except two control units are subjected to each environment. After subjection to an environment, each unit is again subjected to a baseline test. Examination of baseline test results before and after an environment will provide insight into degradation of performance, if any, in a unit due to the environment. The callouts in the boxes of Figure 3-11, i.e., F-1, F-12, etc., correspond to task designations and also appear with the tabulated data presented in Volume II of this report for cross correlation.

3.10 DATA ANALYSIS

An extraordinary amount of data was generated in the course of this program; 3228 performance curves were generated. As mentioned previously, three data points were tabulated from each transfer function (the value of frequency at -5, 0 and +5 psi); therefore, approximately 10,000 data points are available for analysis. These data are presented in tabular form and in graph form in Volume II of this report.

Of primary interest is the variation of frequency about a set point as a result of operating conditions. One way of presenting this type of data is in the form of histograms which are graphical representations of frequency distributions. Histograms of the FDAC's in the baseline condition and when subjected to all environments are given in Appendix B.

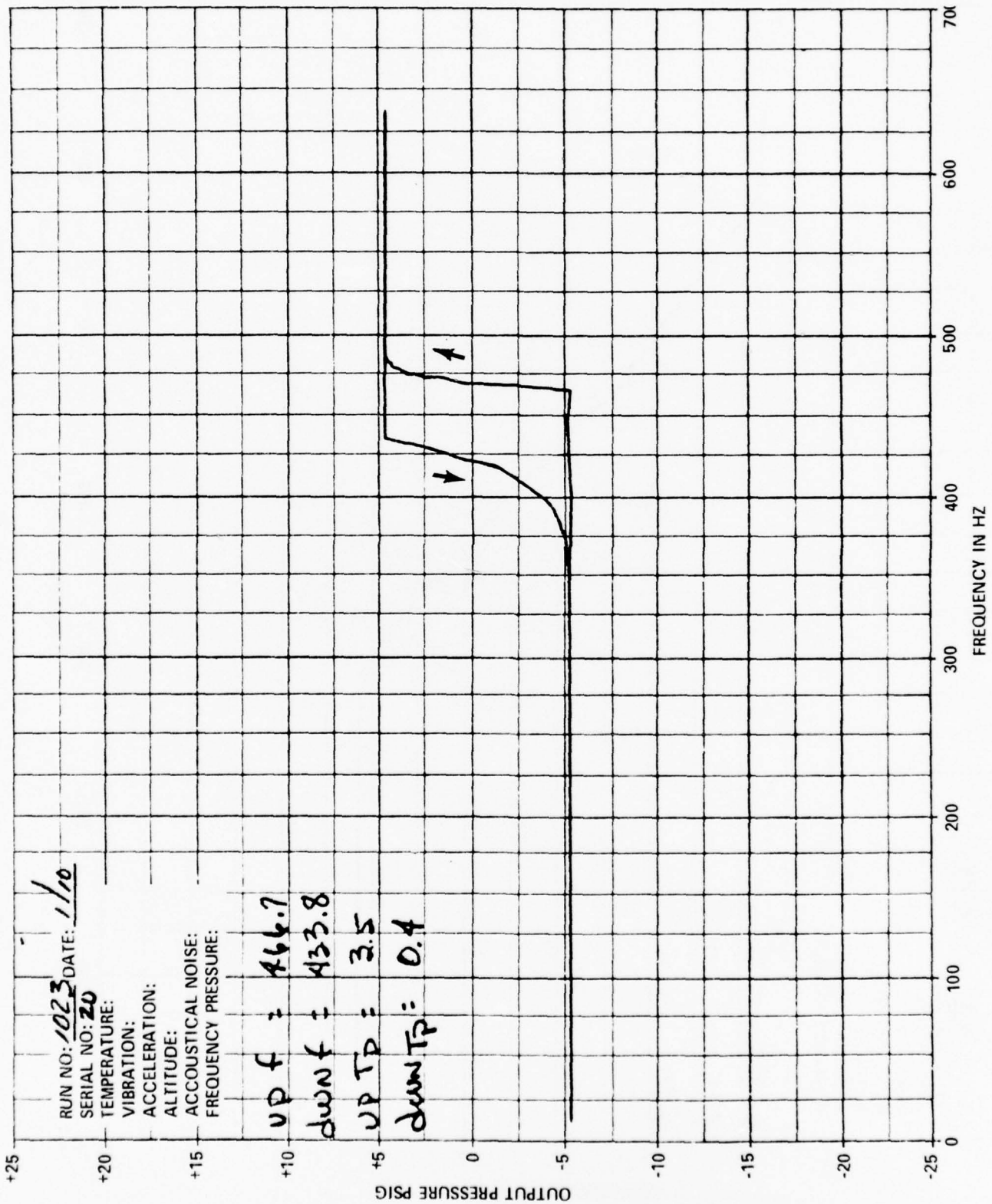

FIGURE 3-10 SCHMITT TRIGGER RESPONSE TO FDAC

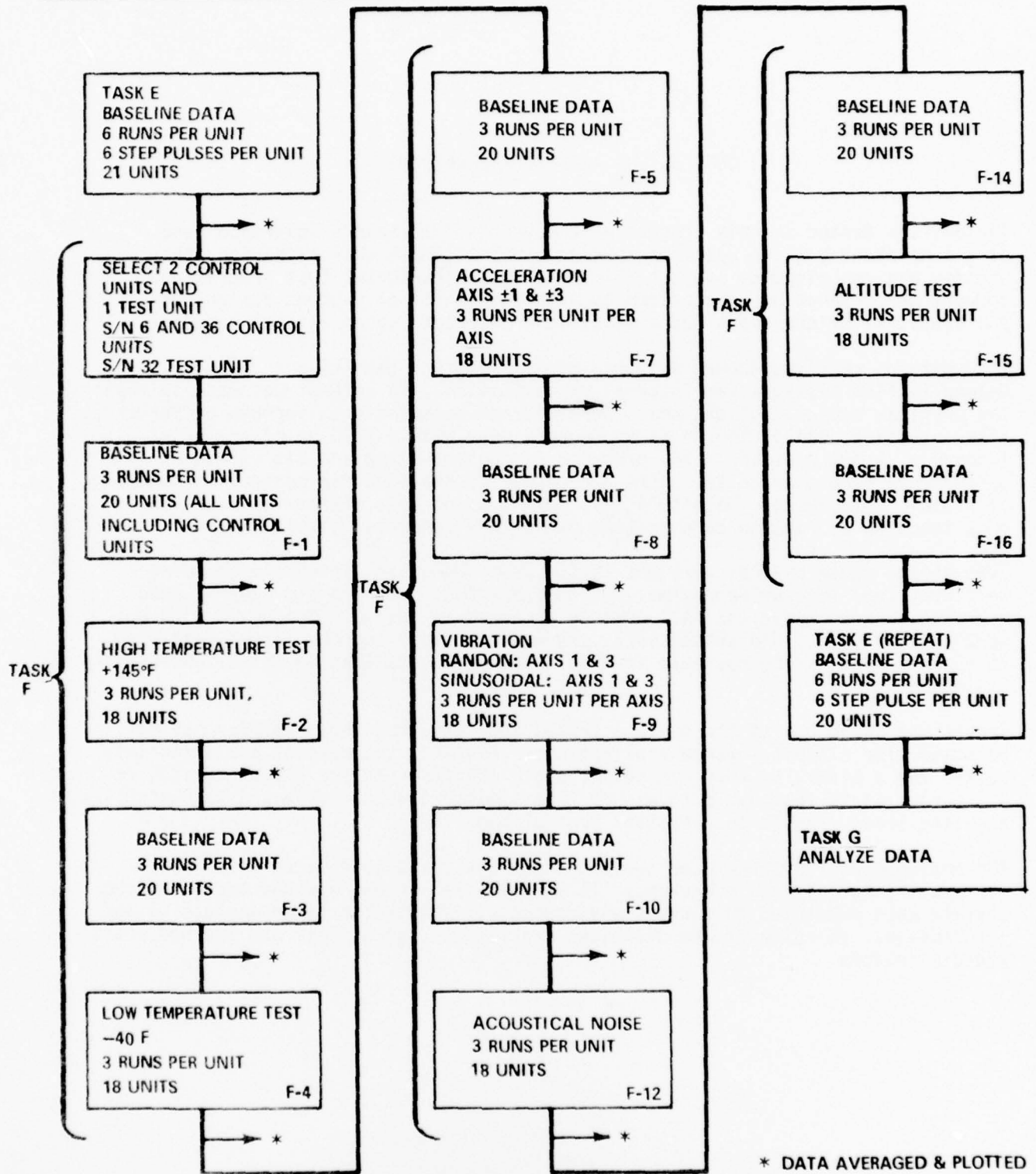

FIGURE 3-11 FDAC TEST SEQUENCE

SECTION 4

CONCLUSIONS AND RECOMMENDATIONS

The devices tested in this program were advertised to have a tolerance band of ± 5 Hz about a given operating pressure point. With this criterion, this program was conceived to subject FDAC's to an environmental test program and compare performance (characterized by frequency shift at a given design output pressure) before and after a specific environment to an initial baseline.

The units as received showed evidence of mishandling, resulting in physical damage to flow passages and internal contamination. No attempt was made to repair the physical damage, but the units were cleaned repeatedly to improve performance. After cleaning, 94% of the 84 baseline runs were within ± 30 Hz of set point frequency at set pressure. The presence of contamination and its effect on performance should serve as a strong reminder of the need for controlled handling of fluidic components. Unfortunately, this type of data scatter in baseline runs tends to overshadow data scatter due to environmental stress.

Even though these devices were not in the best condition, it should be noted that they went through approximately 150 operations each and did exhibit good operating characteristics. All devices produced an output. One device did not work initially, but did subsequently produce an output and thereafter continued to operate, indicating possible internal blockage/contamination which subsequently dislodged.

Variations in output of the devices tested indicate that these samples may not be suited for close tolerance applications. However, the devices are definitely suited for a binary type of operation; e.g., all fire-no fire (>650 Hz, <250 Hz @ 5 psi). It is reasonable to assume that similar devices subjected to controlled handling should result in a smaller control band.

The environmental program used to test these devices should serve as a basis for qualifying any future devices. It is definitely known now how these devices operate when subjected to various environments. The test program was useful and informative. In spite of the drawbacks mentioned, a great deal was learned about fluidic devices.

APPENDIX A

**PHOTOGRAPHS OF FDAC'S
ON RECEIPT**

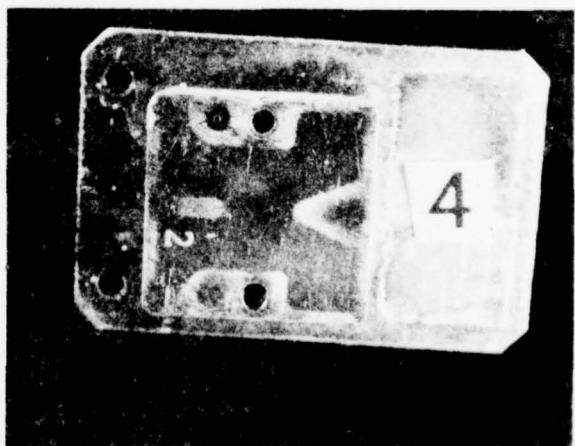
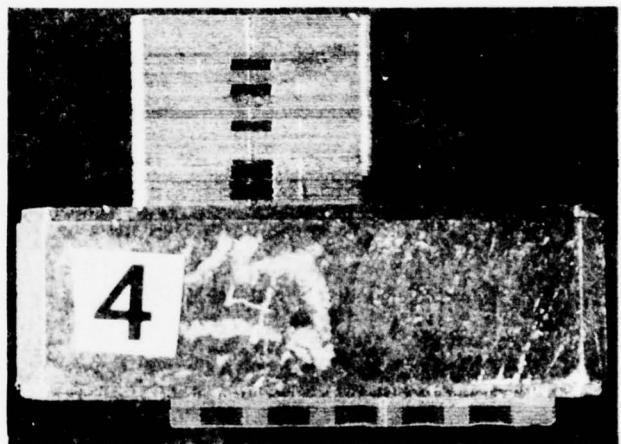
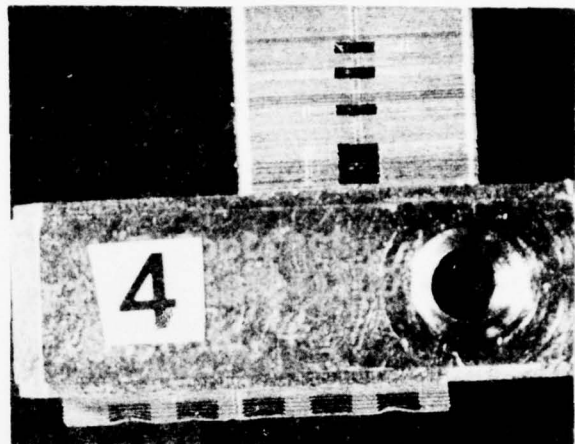
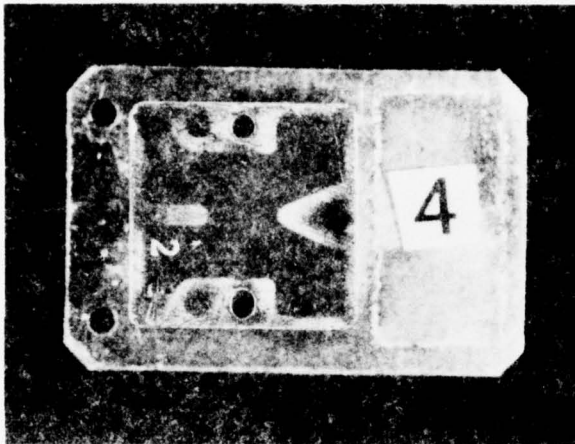

FIGURE A-1
60

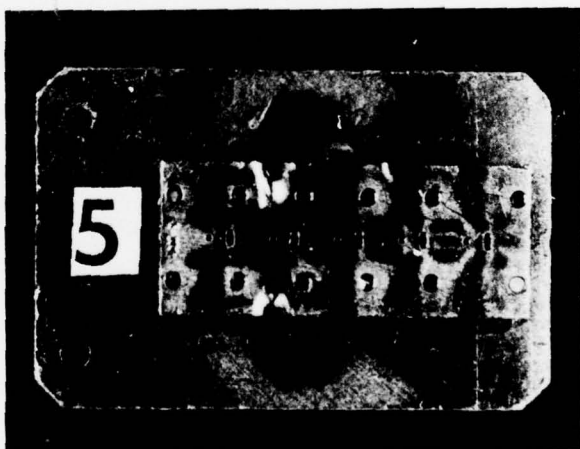
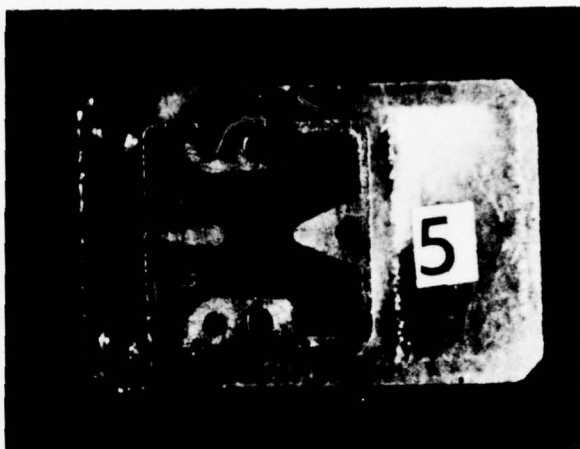

FIGURE A-2
61

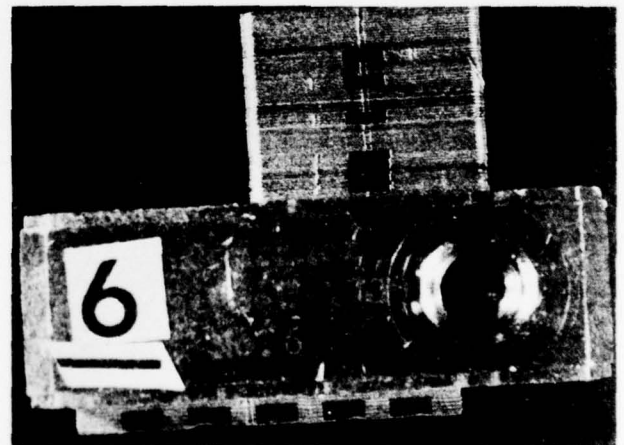
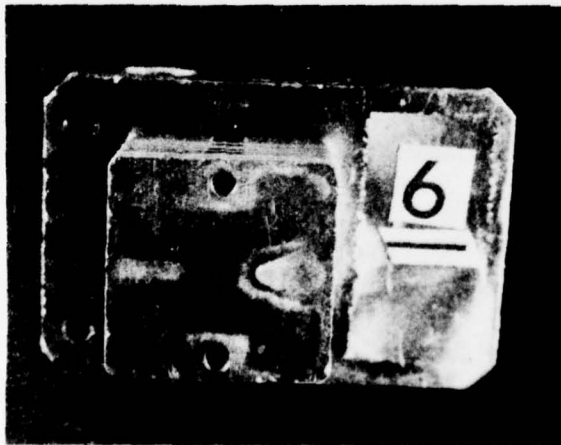
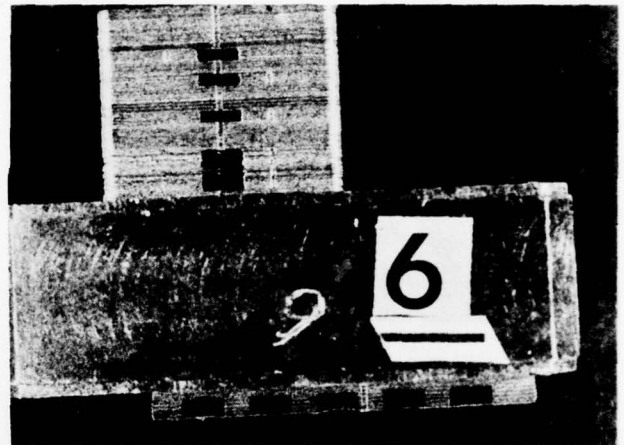

FIGURE A-3

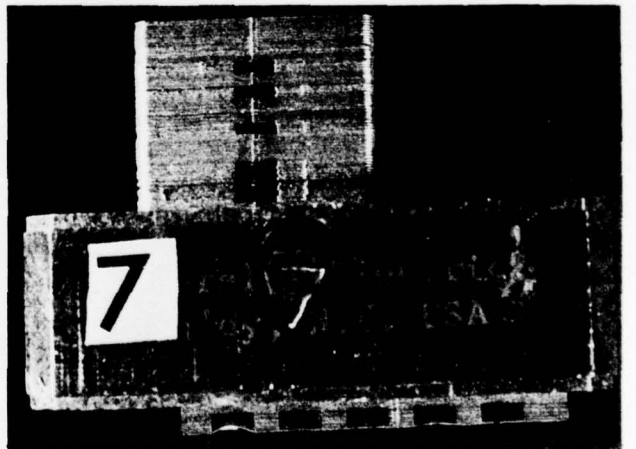
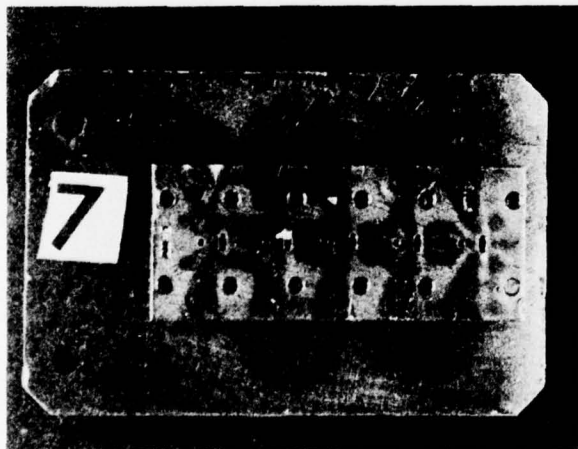
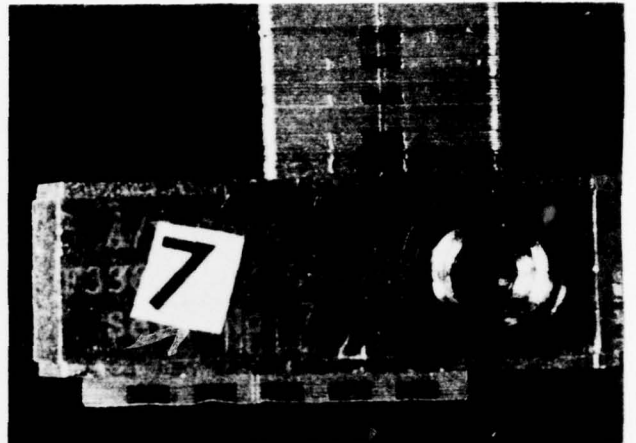
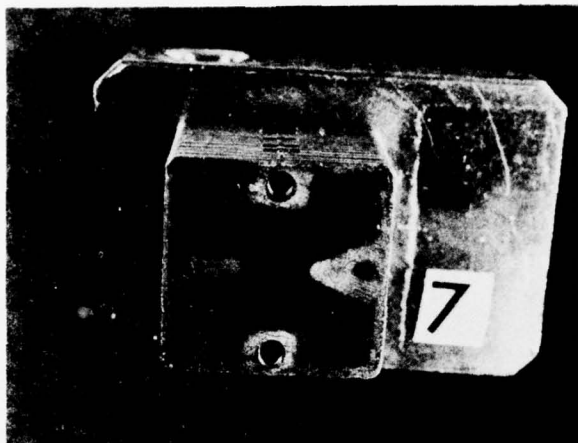

FIGURE A-4

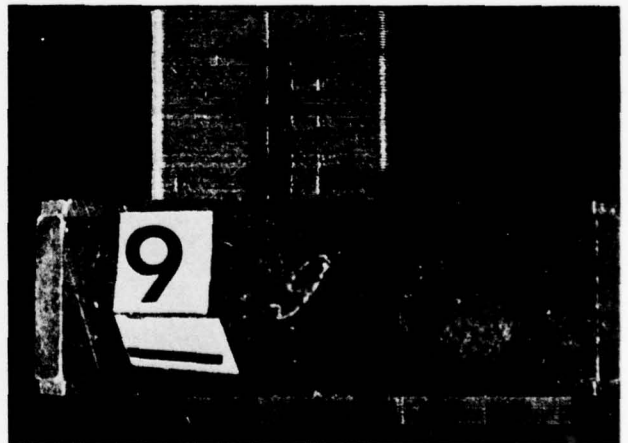
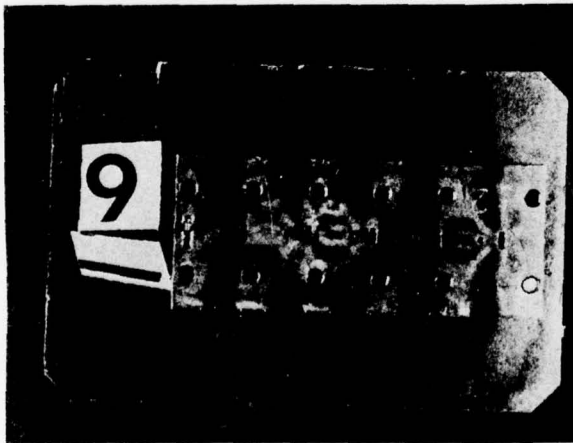
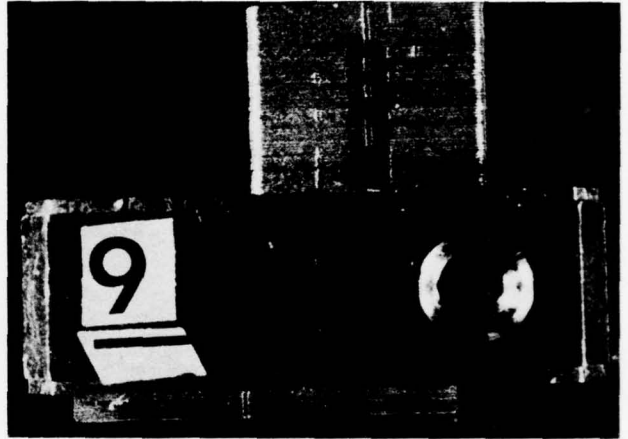
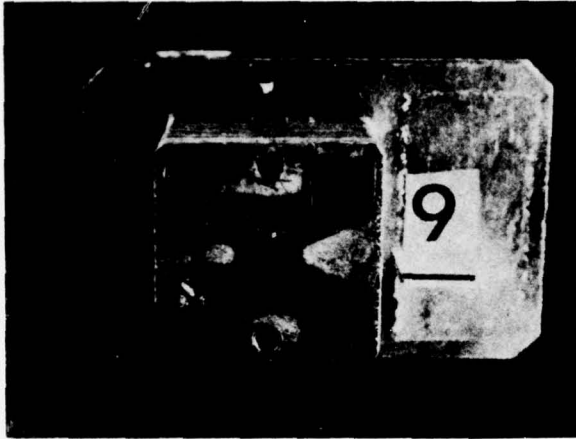

FIGURE A-5

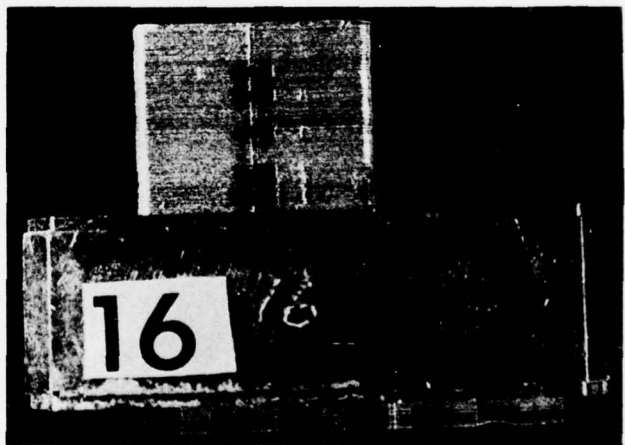
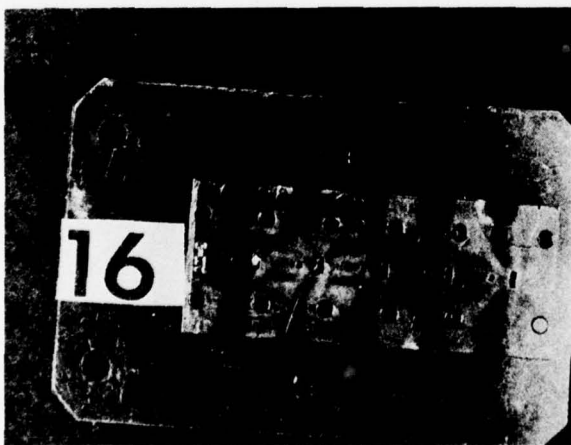
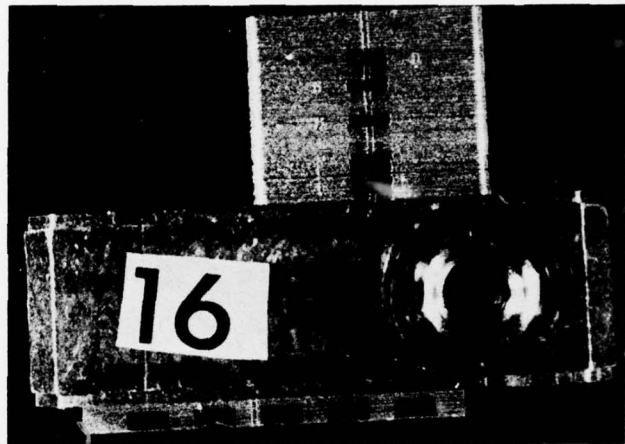
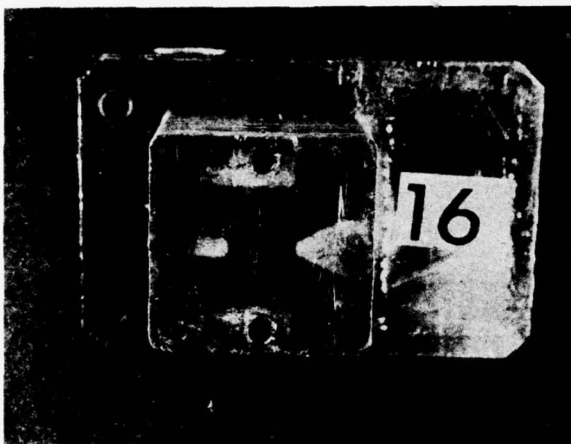

FIGURE A-6

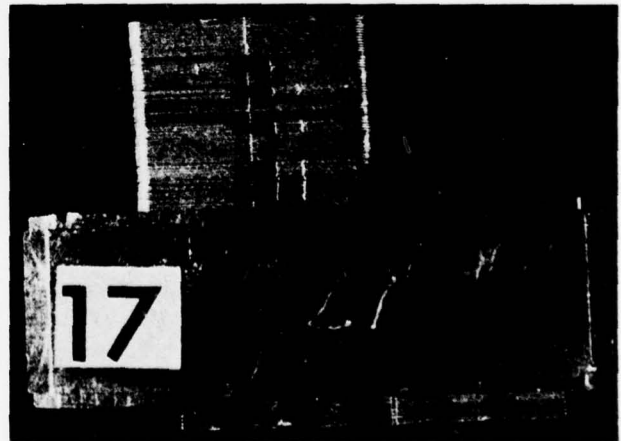
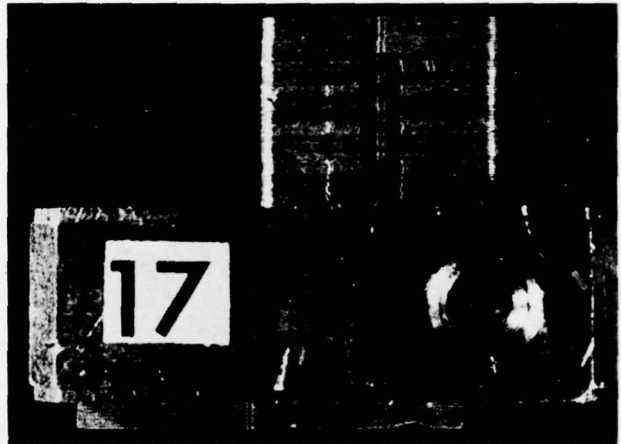

FIGURE A-7

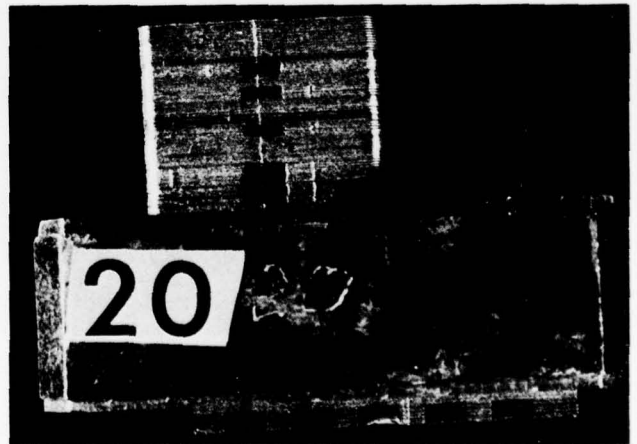
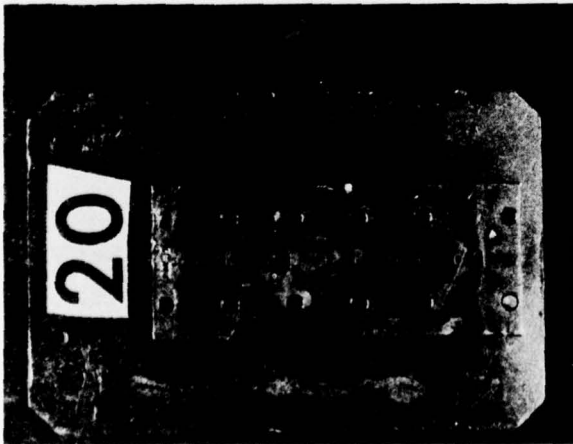
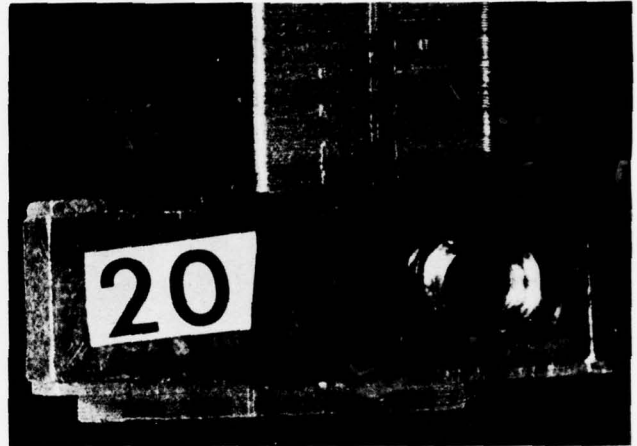
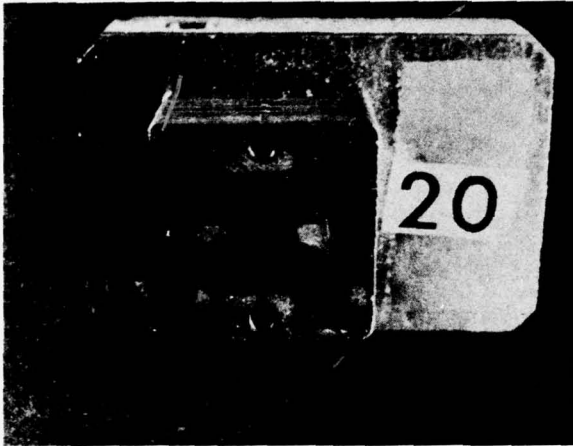

FIGURE A-8

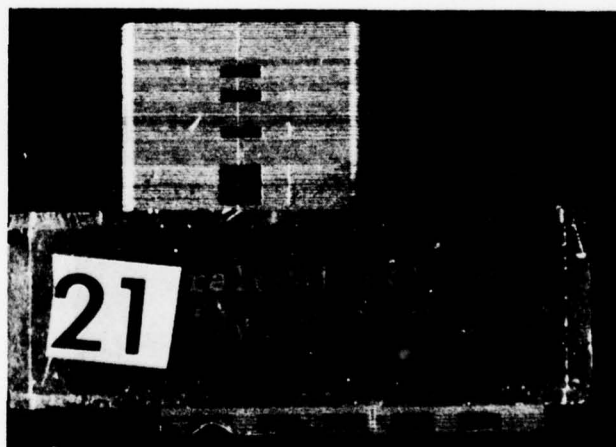
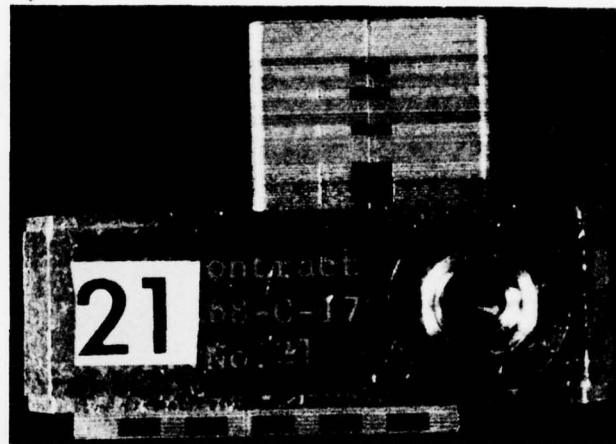

FIGURE A-9

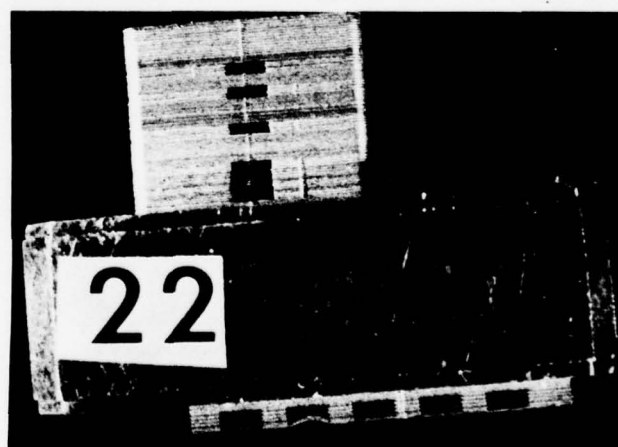
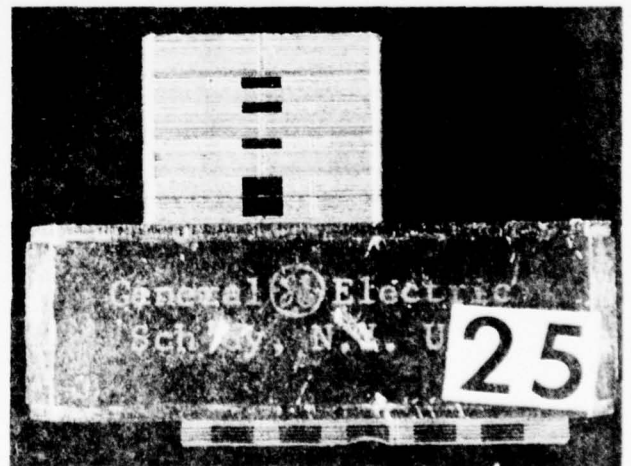
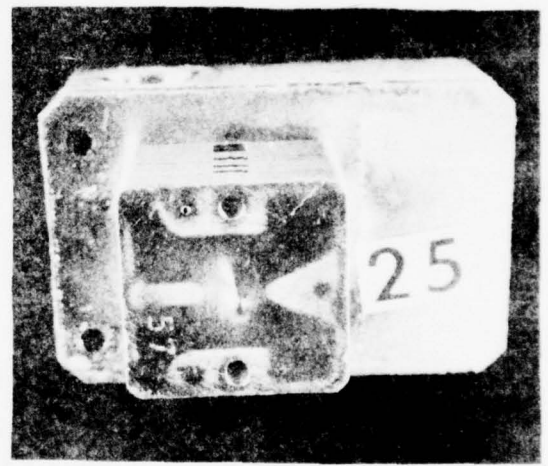
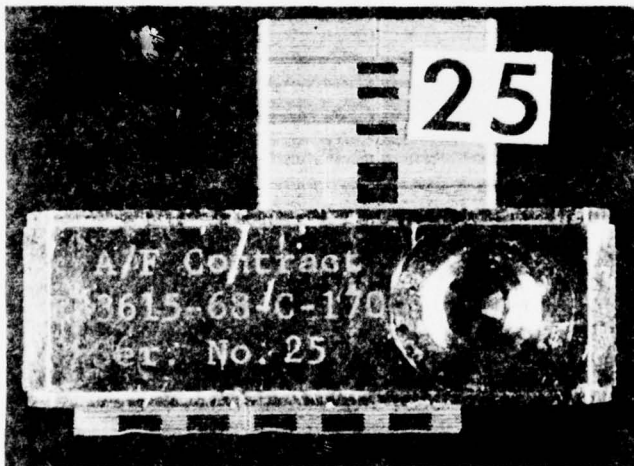
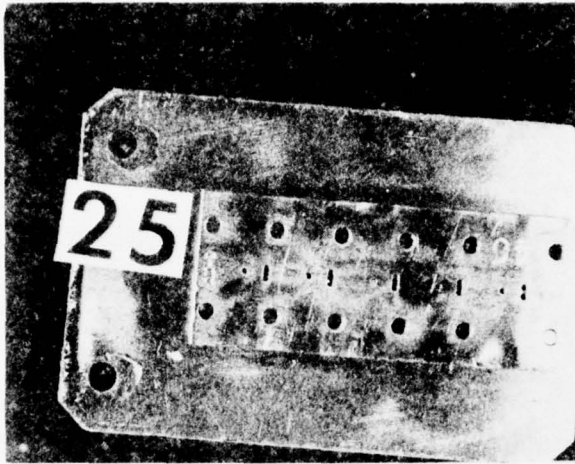

FIGURE A-10
69



S/N 25

FIGURE A-11
70

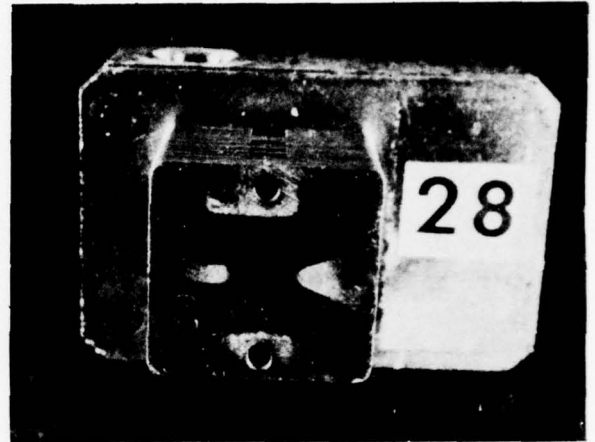
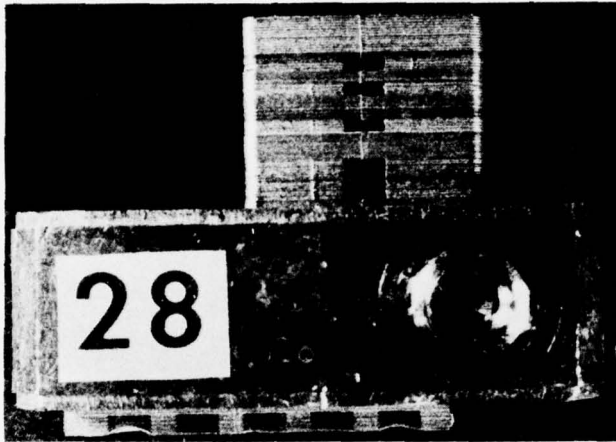

FIGURE A-12

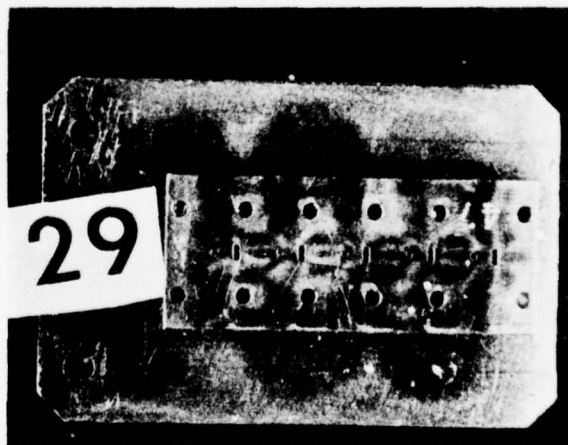
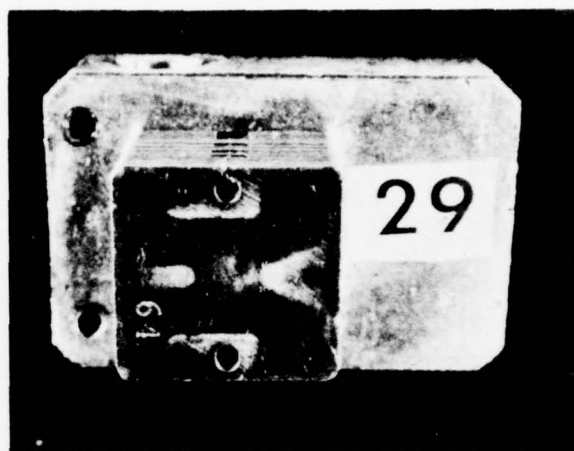

FIGURE A-13

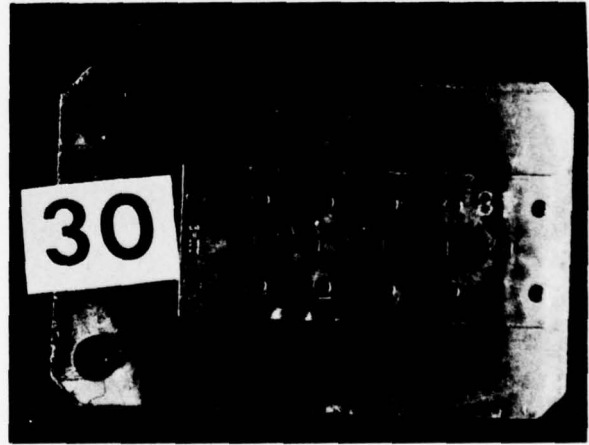
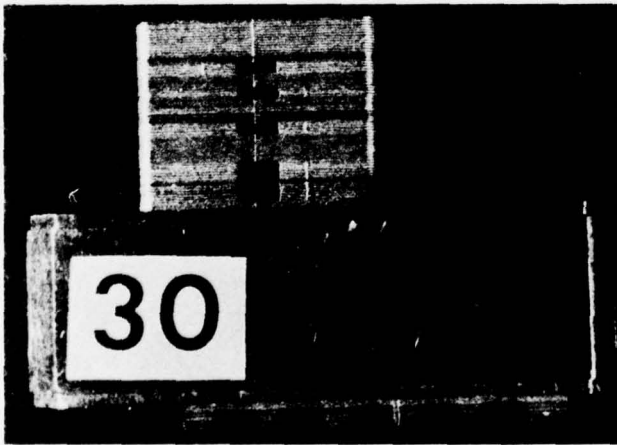
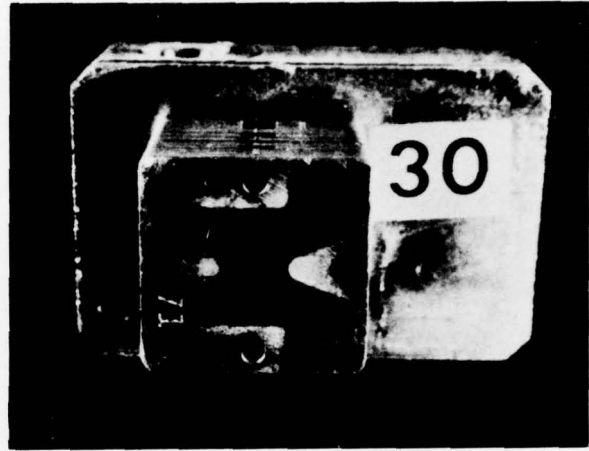
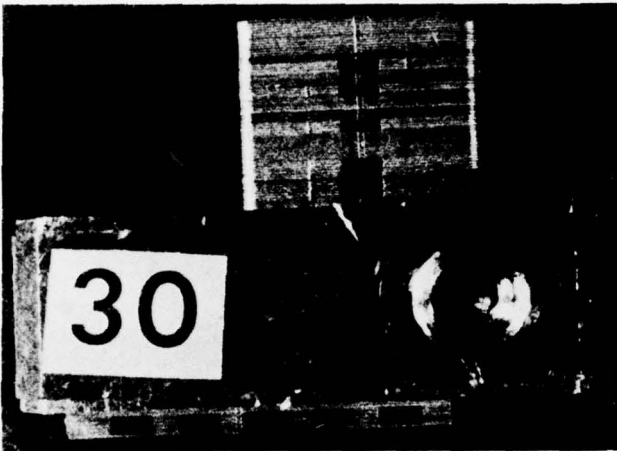

FIGURE A-14

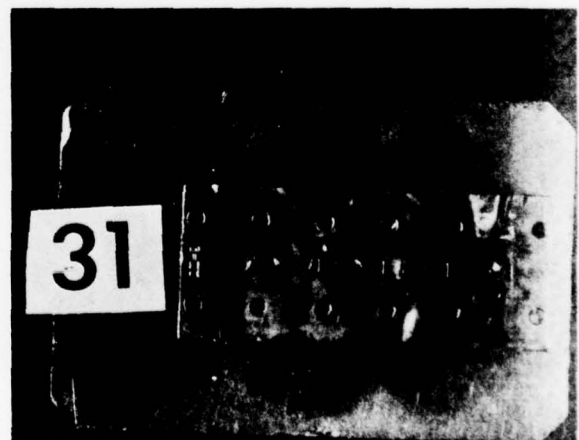
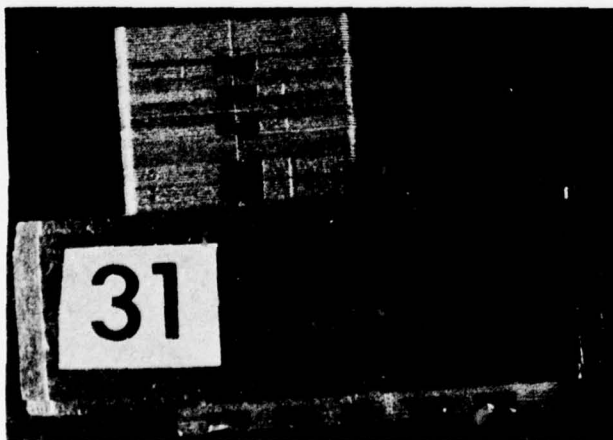
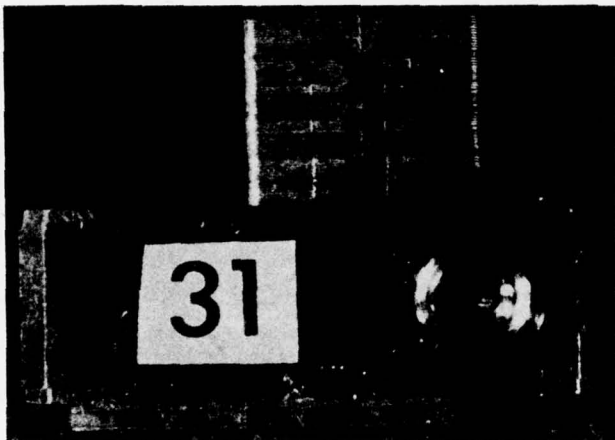

FIGURE A-15

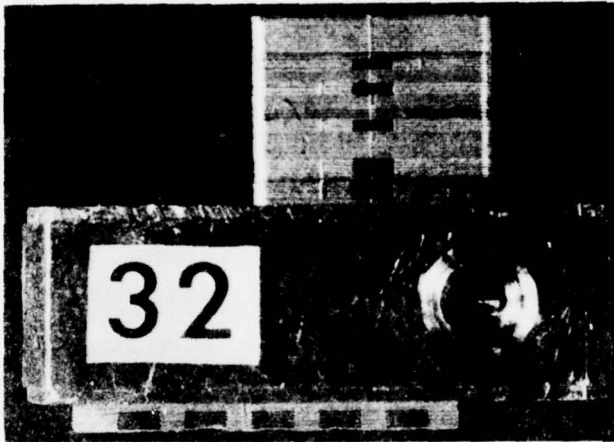

FIGURE A-16
75

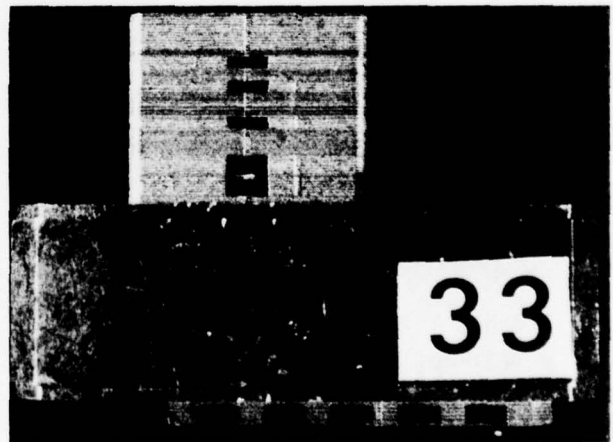
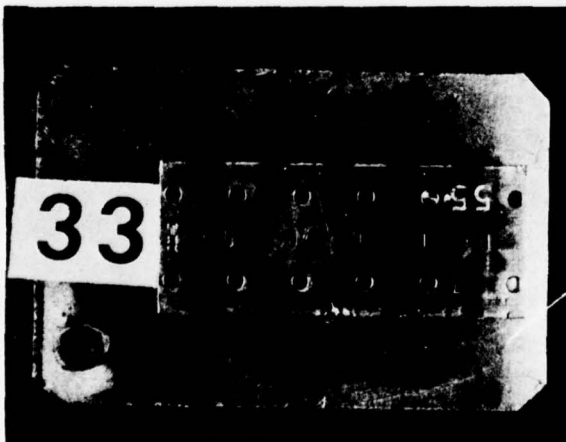
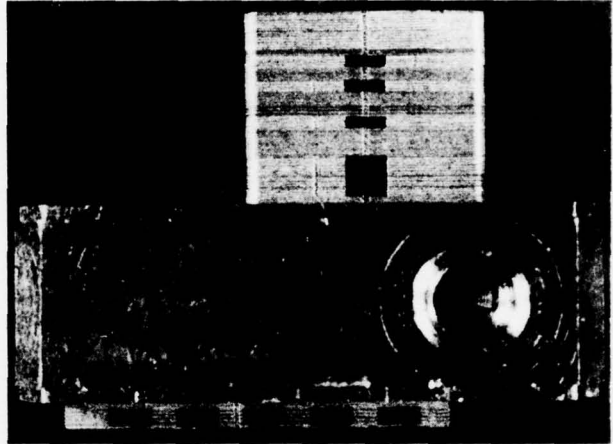
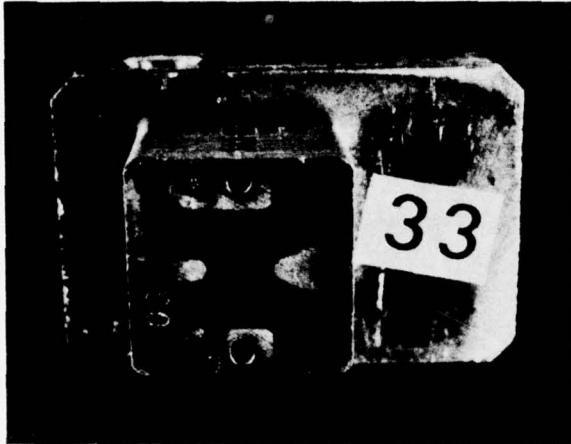

FIGURE A-17
76

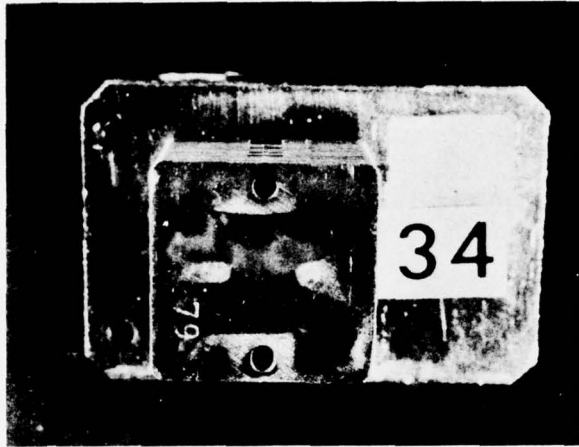

FIGURE A-18
77

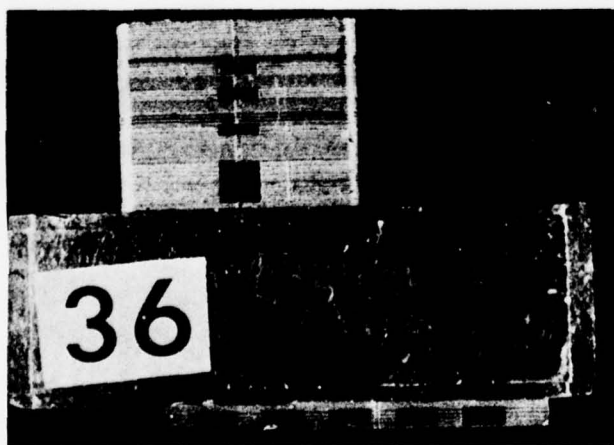
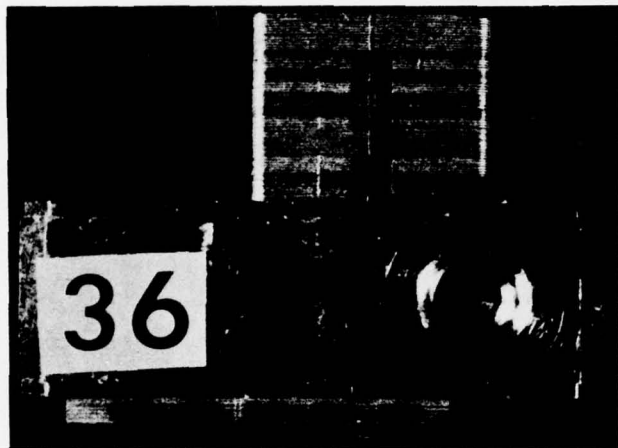

FIGURE A-19
78

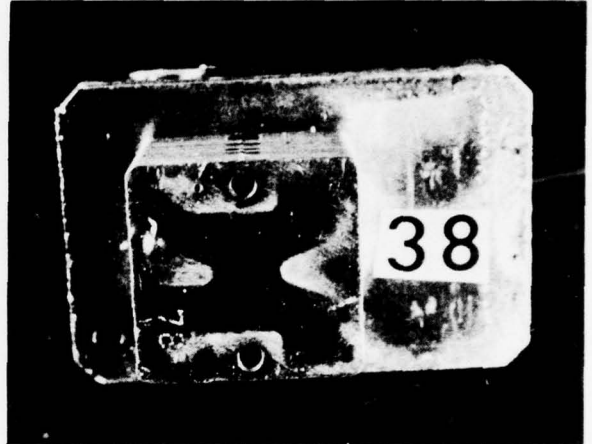

FIGURE A-20
79

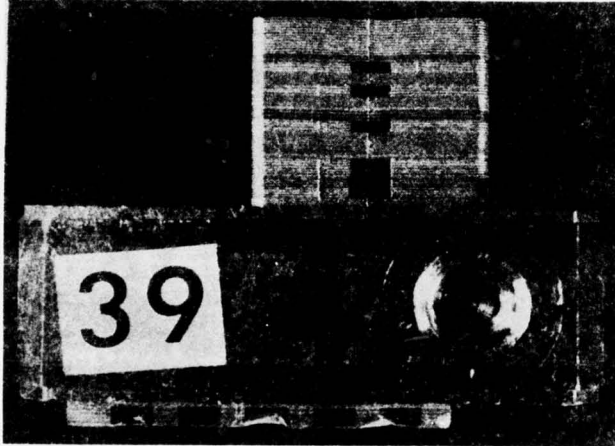

FIGURE A-21
80

APPENDIX B
HISTOGRAMS OF FDAC'S

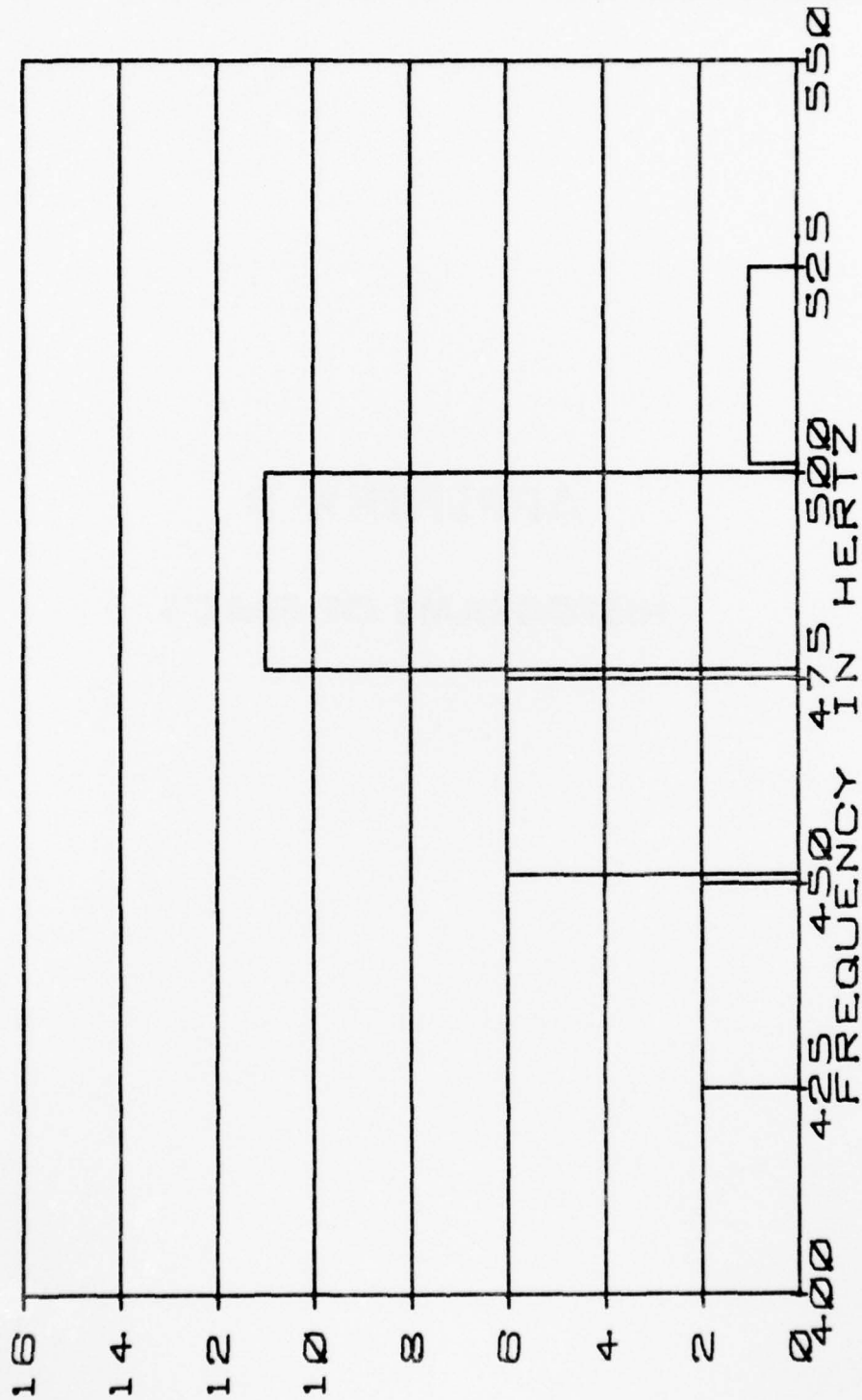

FIGURE B-1 PRE ENVIRONMENTAL BASELINE

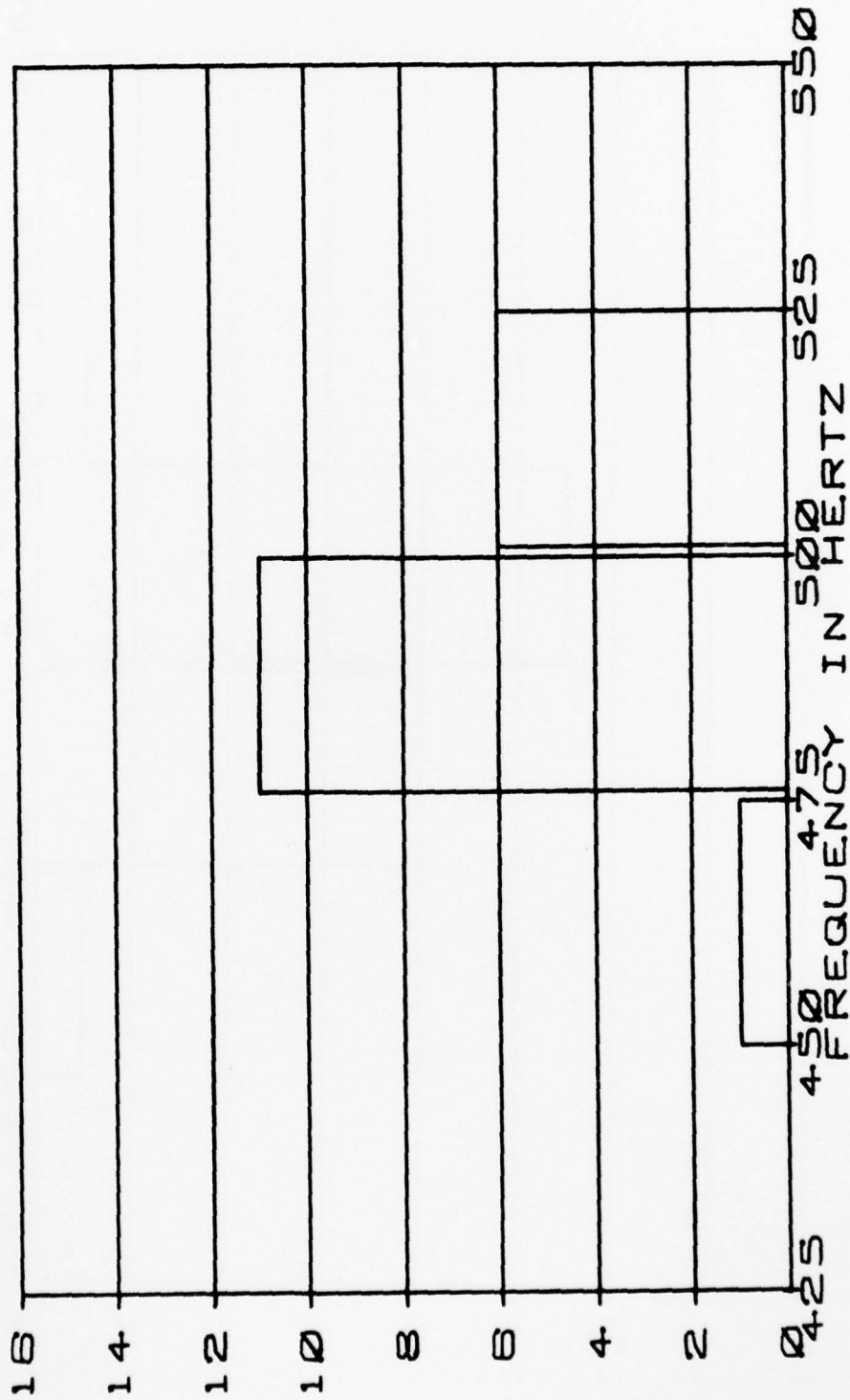

FIGURE B-2 OPERATION AT HIGH TEMPERATURE

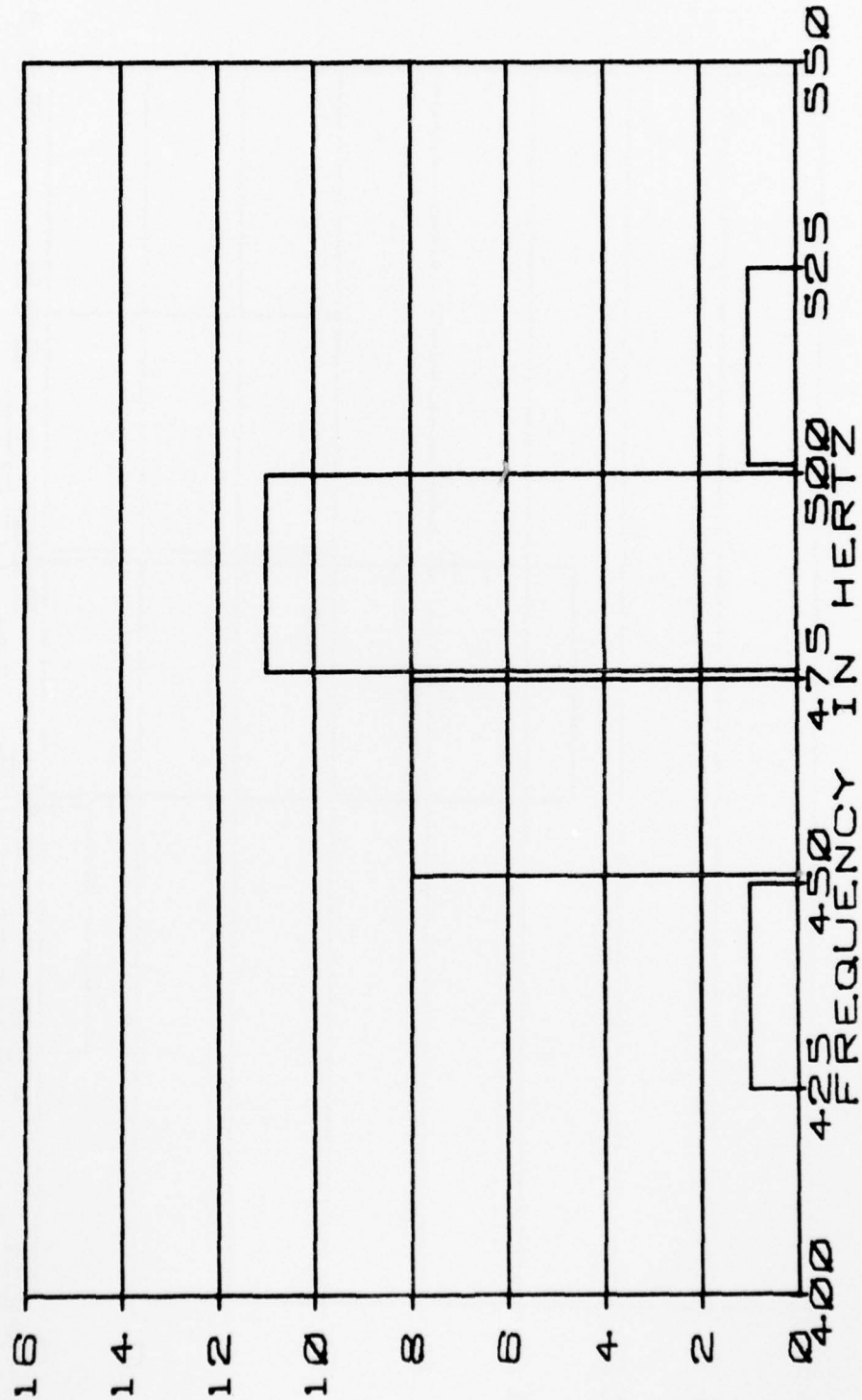

FIGURE B-3 POST HIGH TEMPERATURE BASELINE

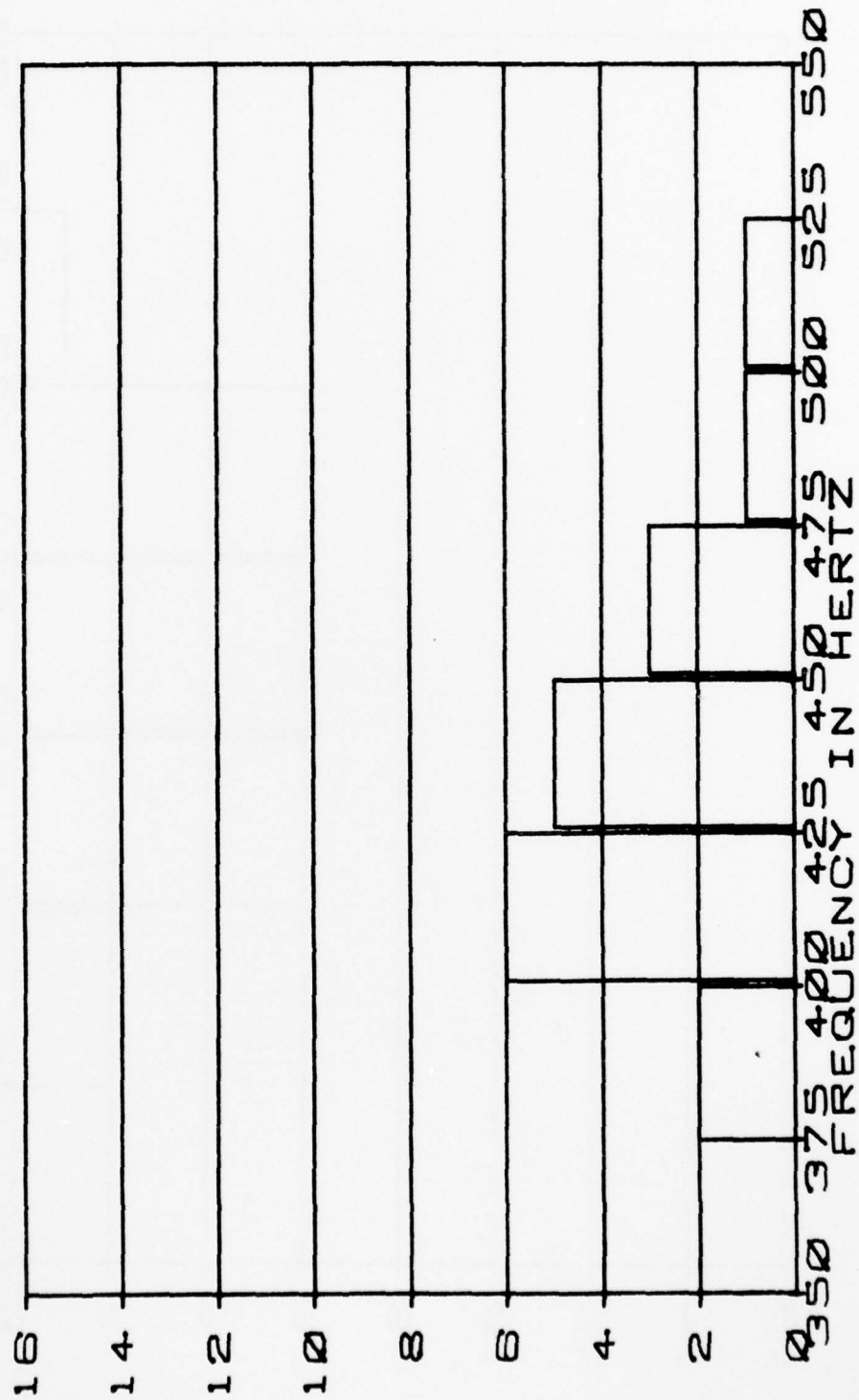

FIGURE B-4 OPERATION AT LOW TEMPERATURE

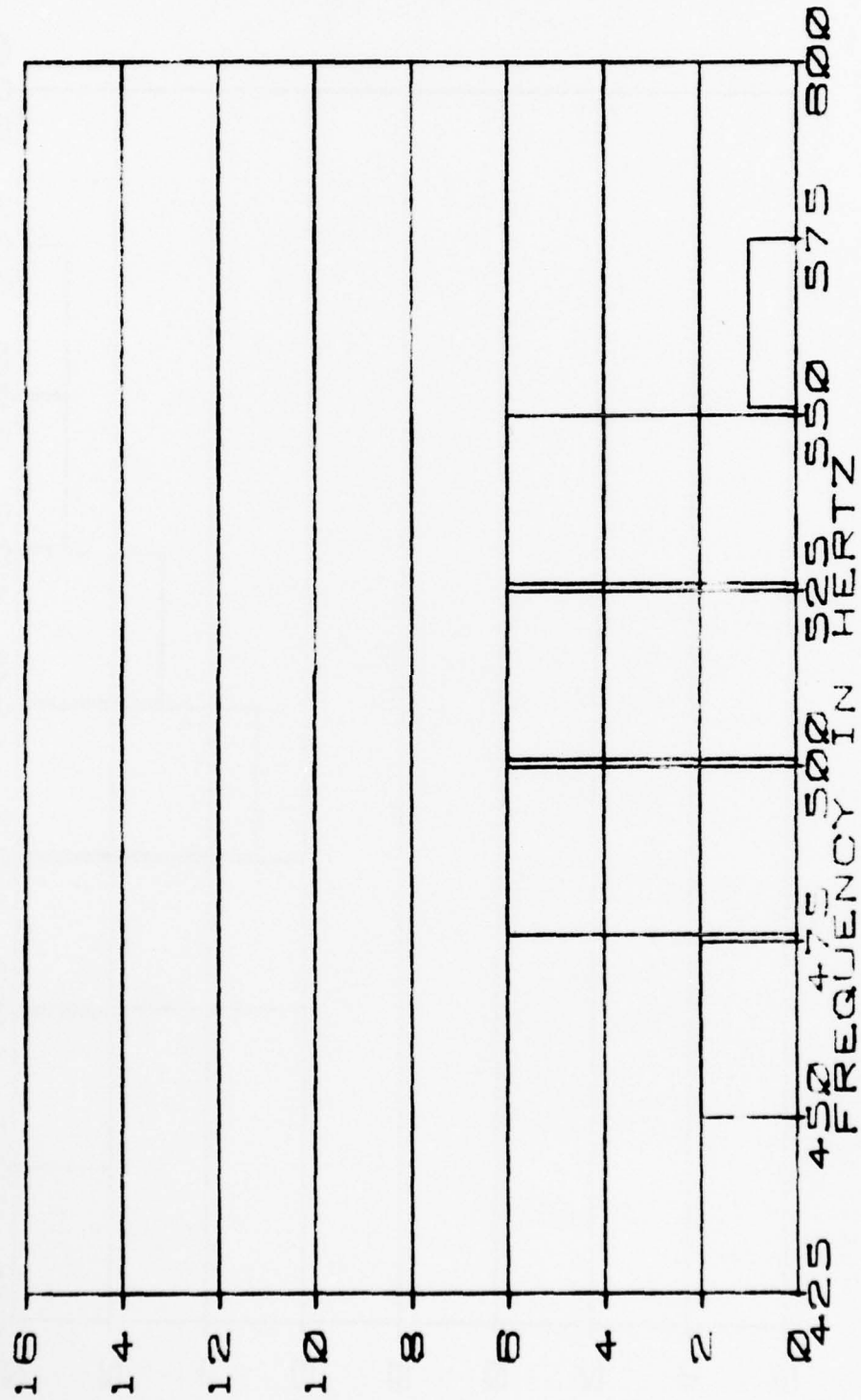

FIGURE B-5 POST LOW TEMPERATURE BASELINE

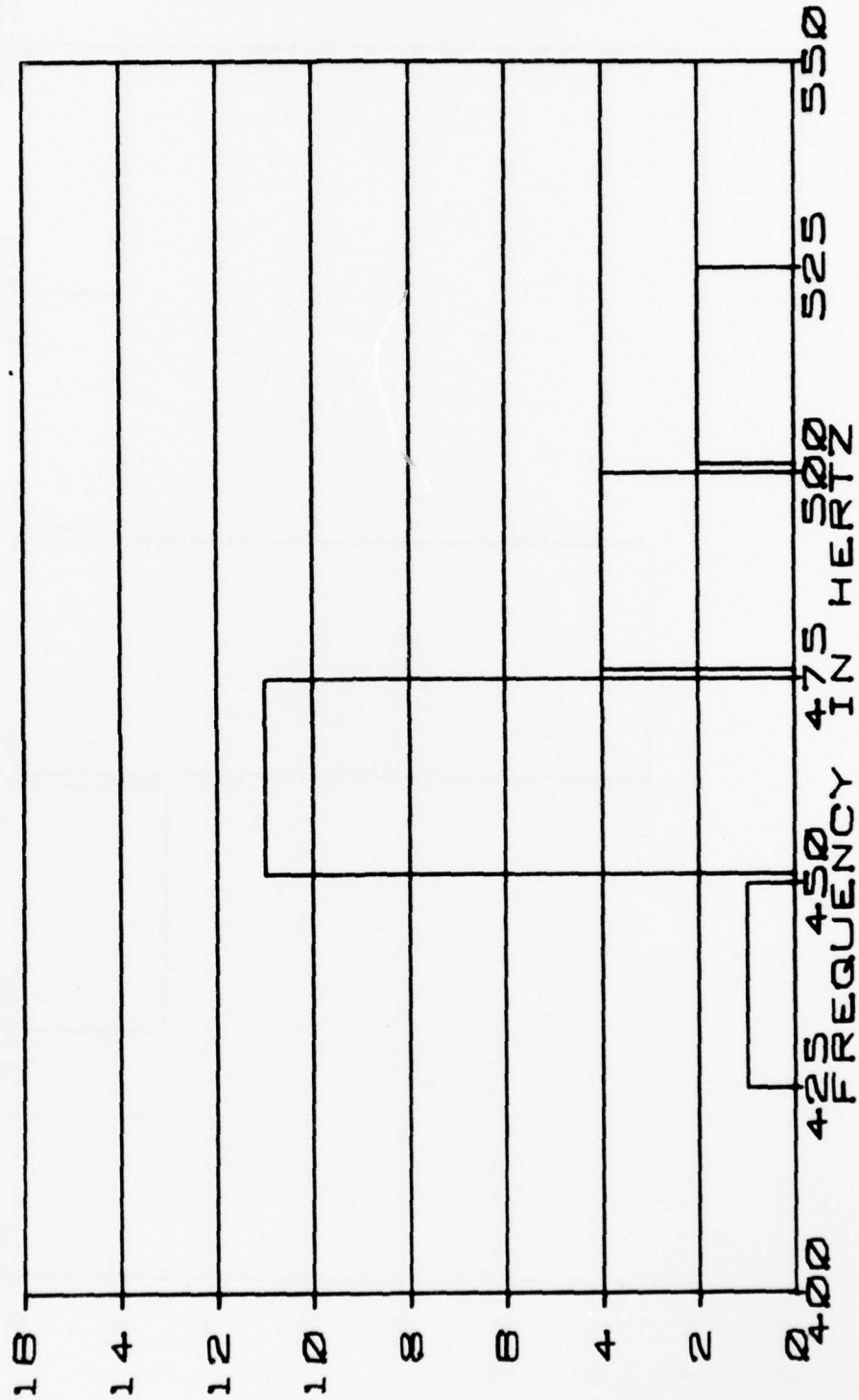

FIGURE B-6 OPERATION DURING ACCELERATION +1 AXIS

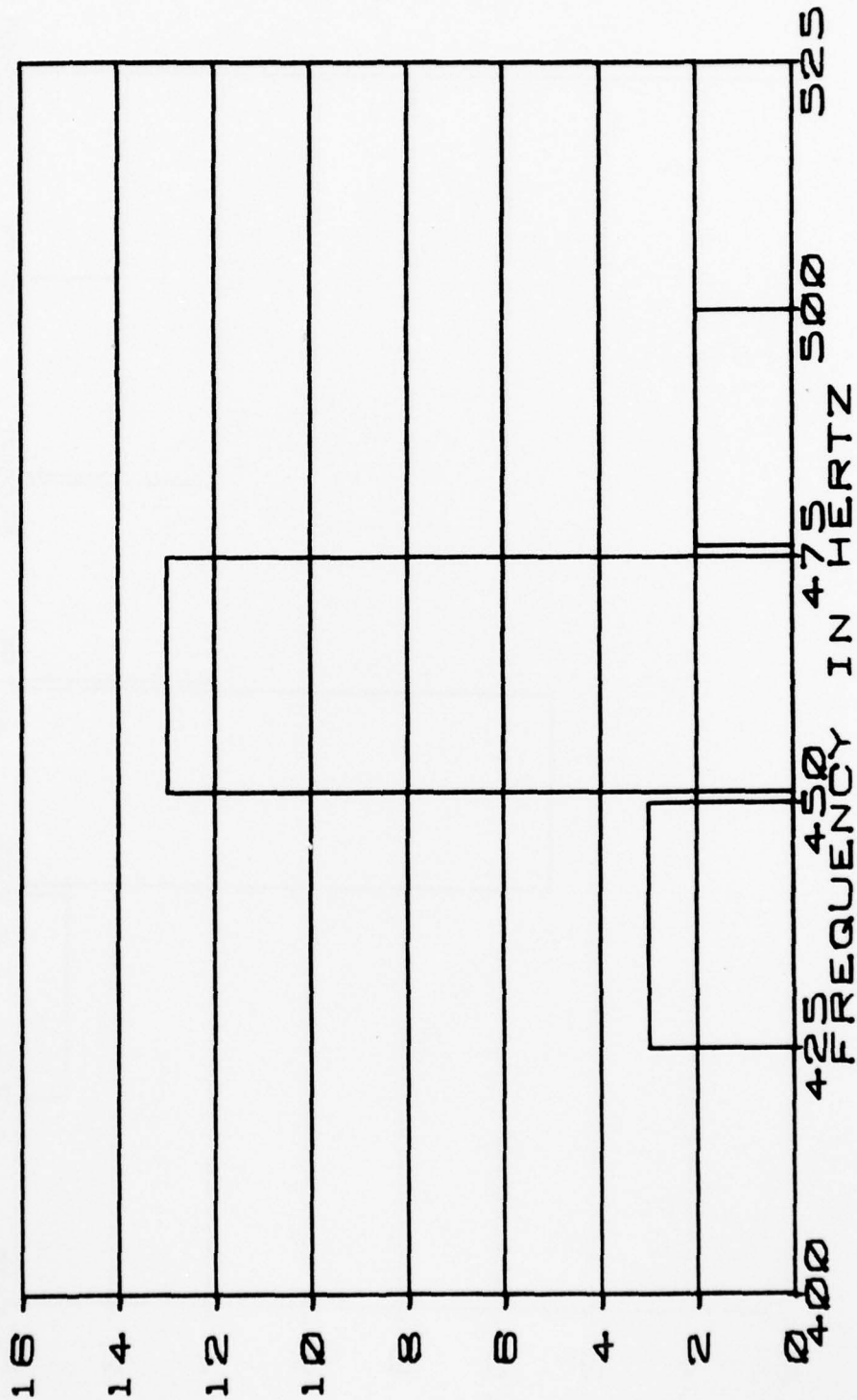

FIGURE B-7 OPERATION DURING ACCELERATION -1 AXIS

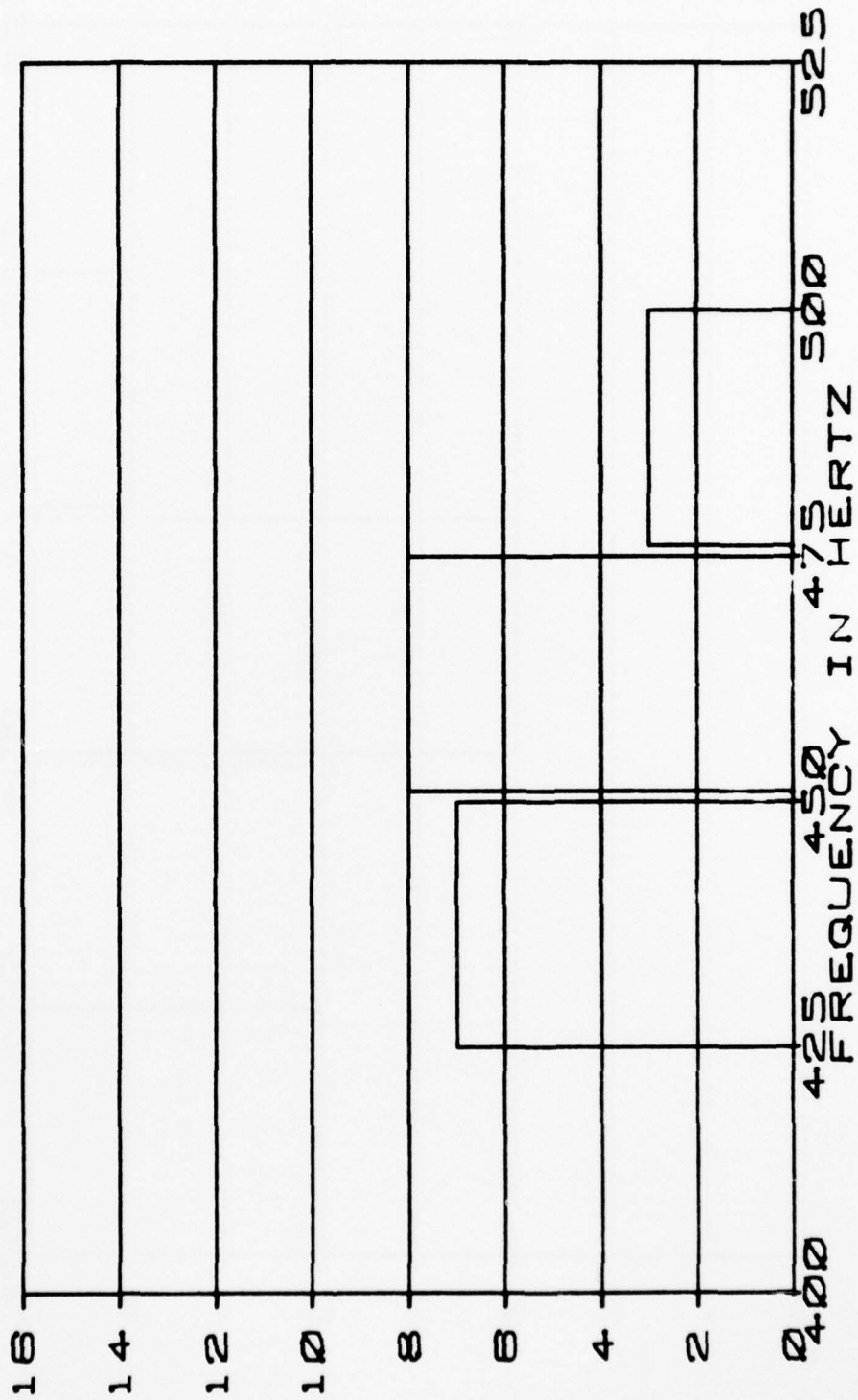

FIGURE B-8 OPERATION DURING ACCELERATION -3 AXIS

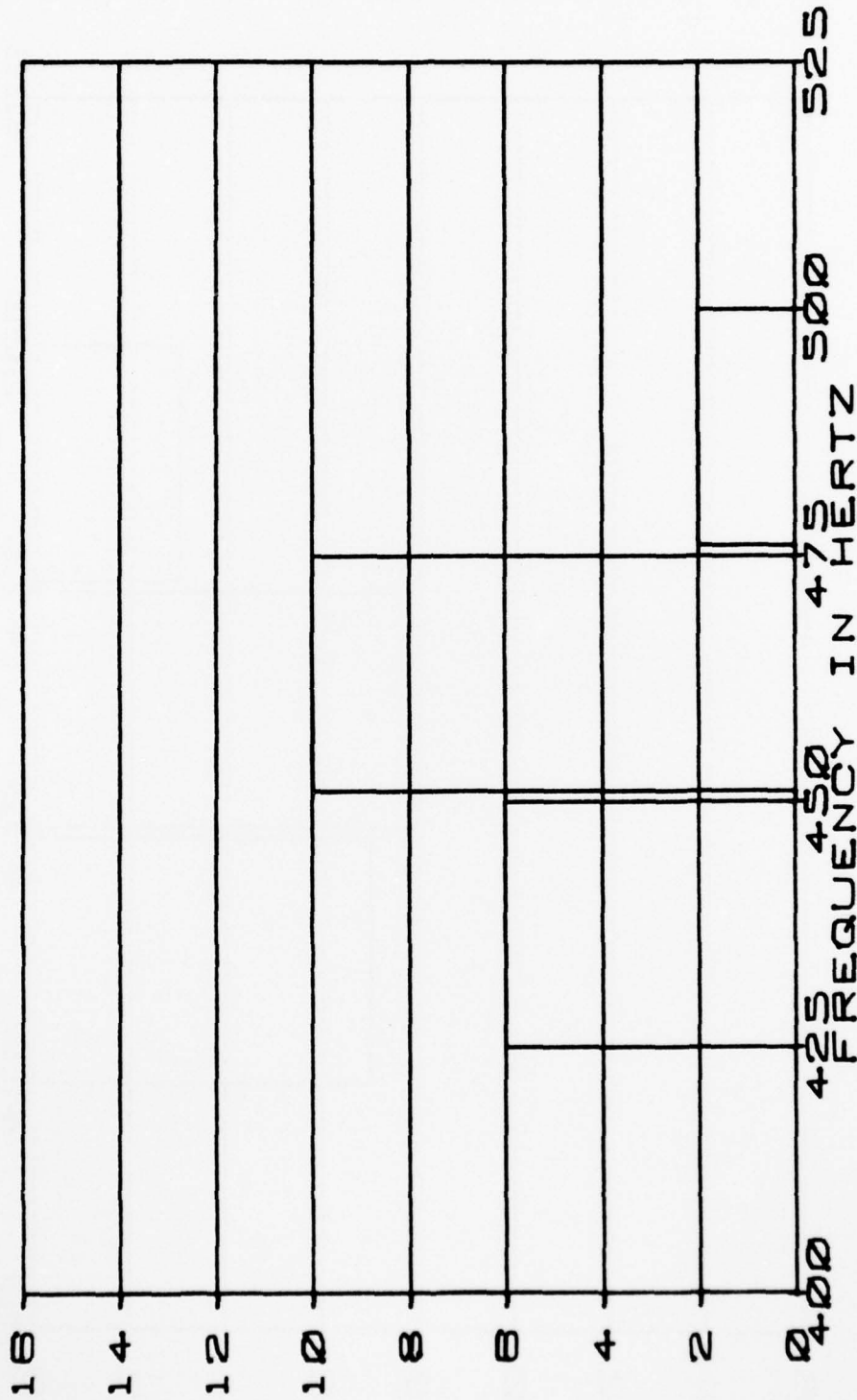

FIGURE B-9 OPERATION DURING ACCELERATION +3 AXIS

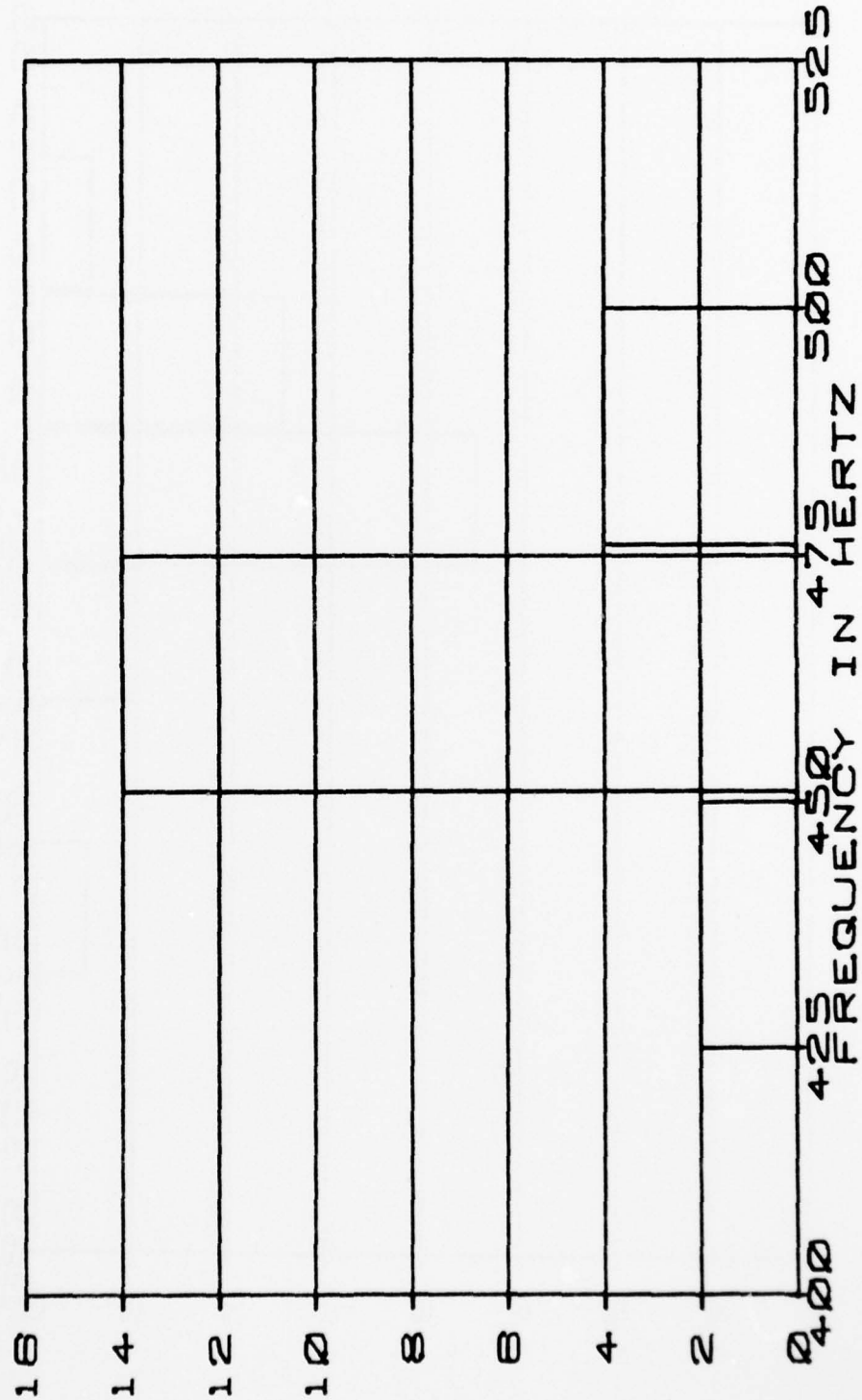

FIGURE B-10 POST ACCELERATION BASELINE

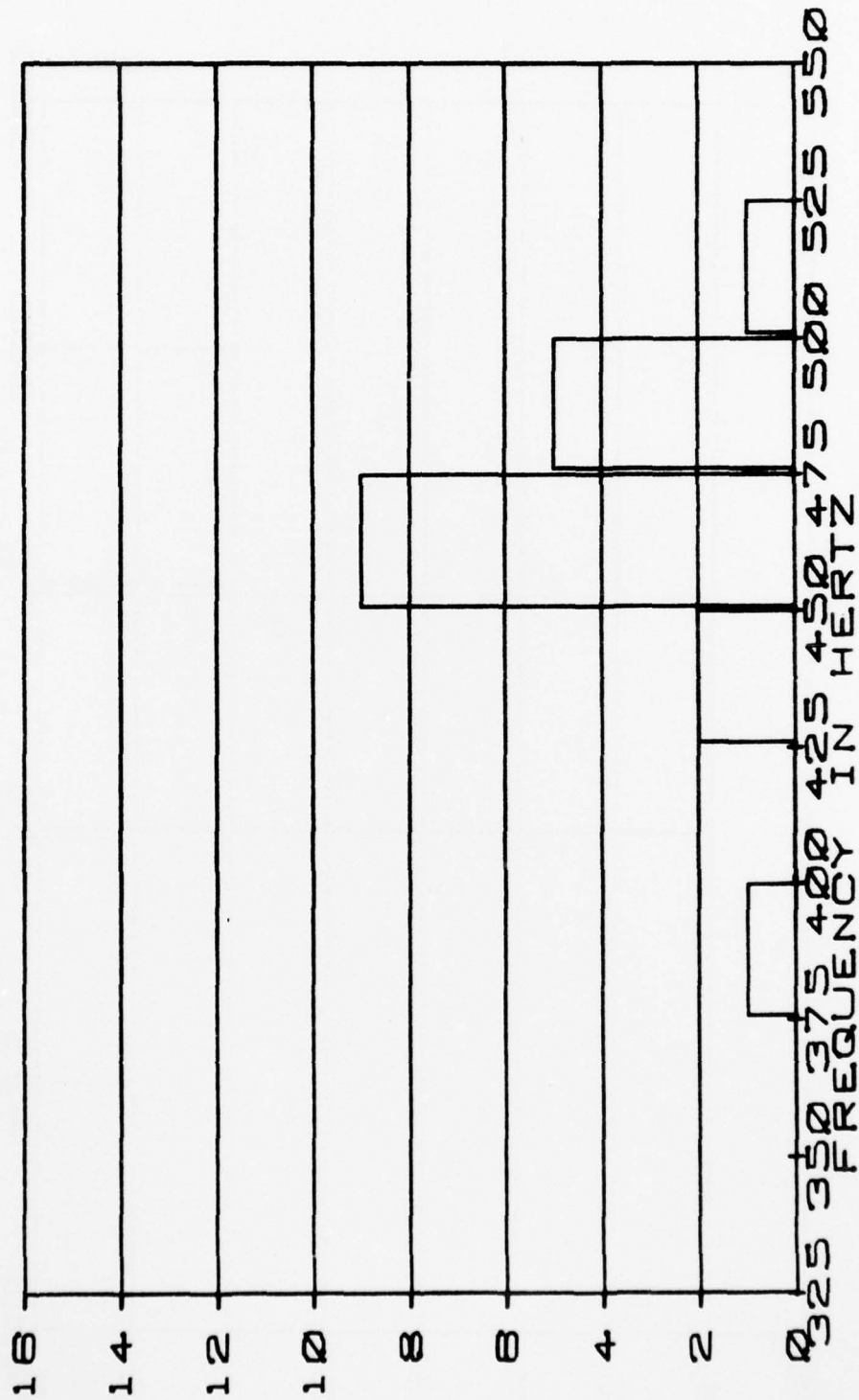

FIGURE B-11 OPERATION DURING VIBRATION AXIS 3

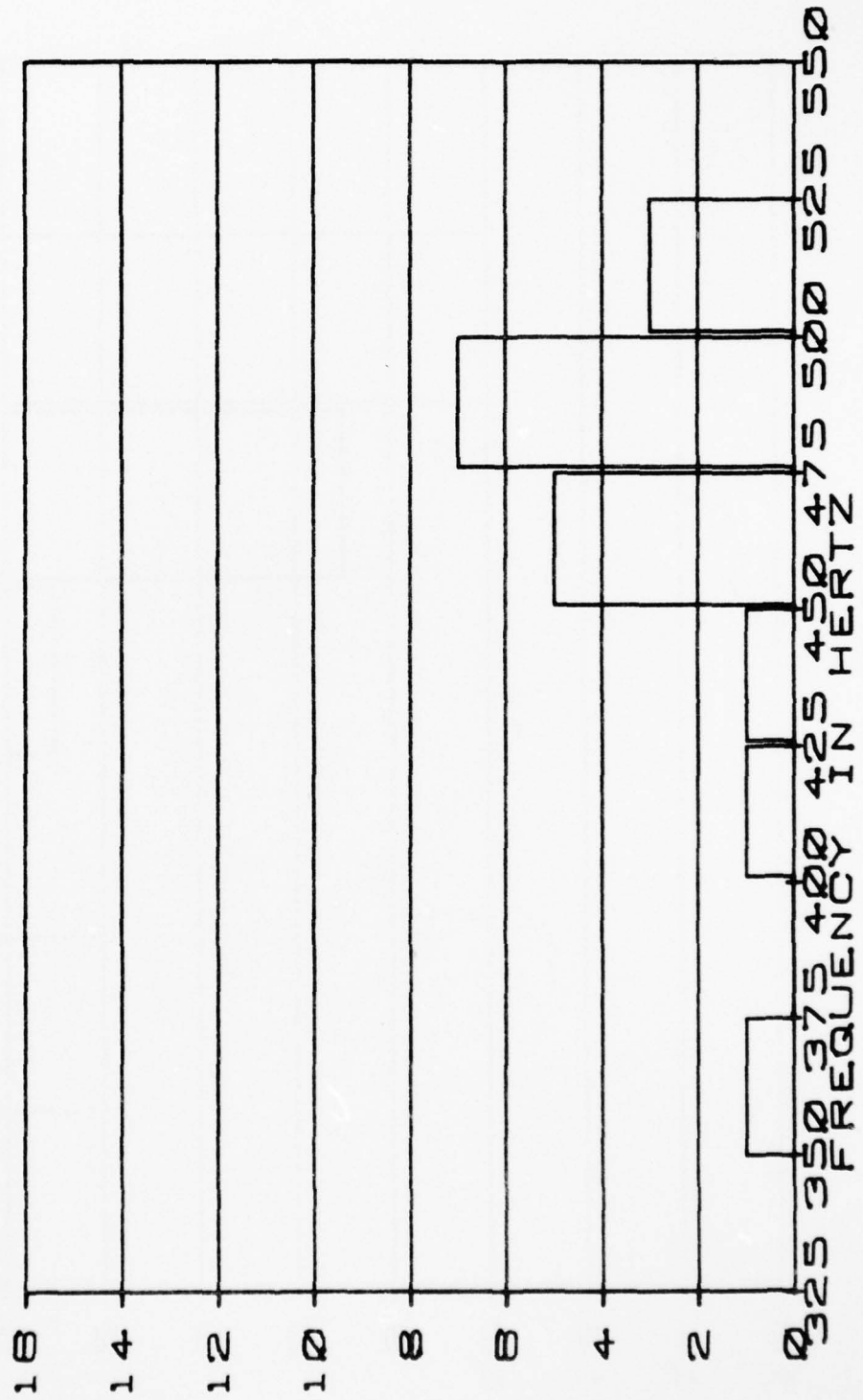

FIGURE B-12 OPERATION DURING VIBRATION AXIS 1

AD-A040 871

MCDONNELL DOUGLAS ASTRONAUTICS CO TITUSVILLE FLA F/6 9/5
ENVIRONMENTAL TESTING OF A FLUIDIC DIGITAL-TO-ANALOG CONVERTOR.--ETC(U)
JUL 76 G W ROE DAAG39-74-C-0212

UNCLASSIFIED

MDC-L0356-VOL-1

HDL-CR-76-212-1-VOL-1

NL

2 OF 2

AD
A040871

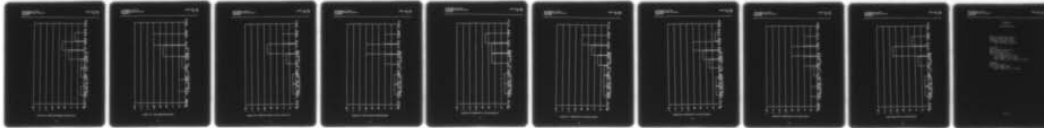

END

DATE
FILMED

7-77

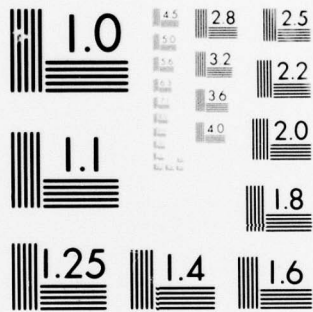

MICROCOPY RESOLUTION TEST CHART
NATIONAL BUREAU OF STANDARDS-1963-A

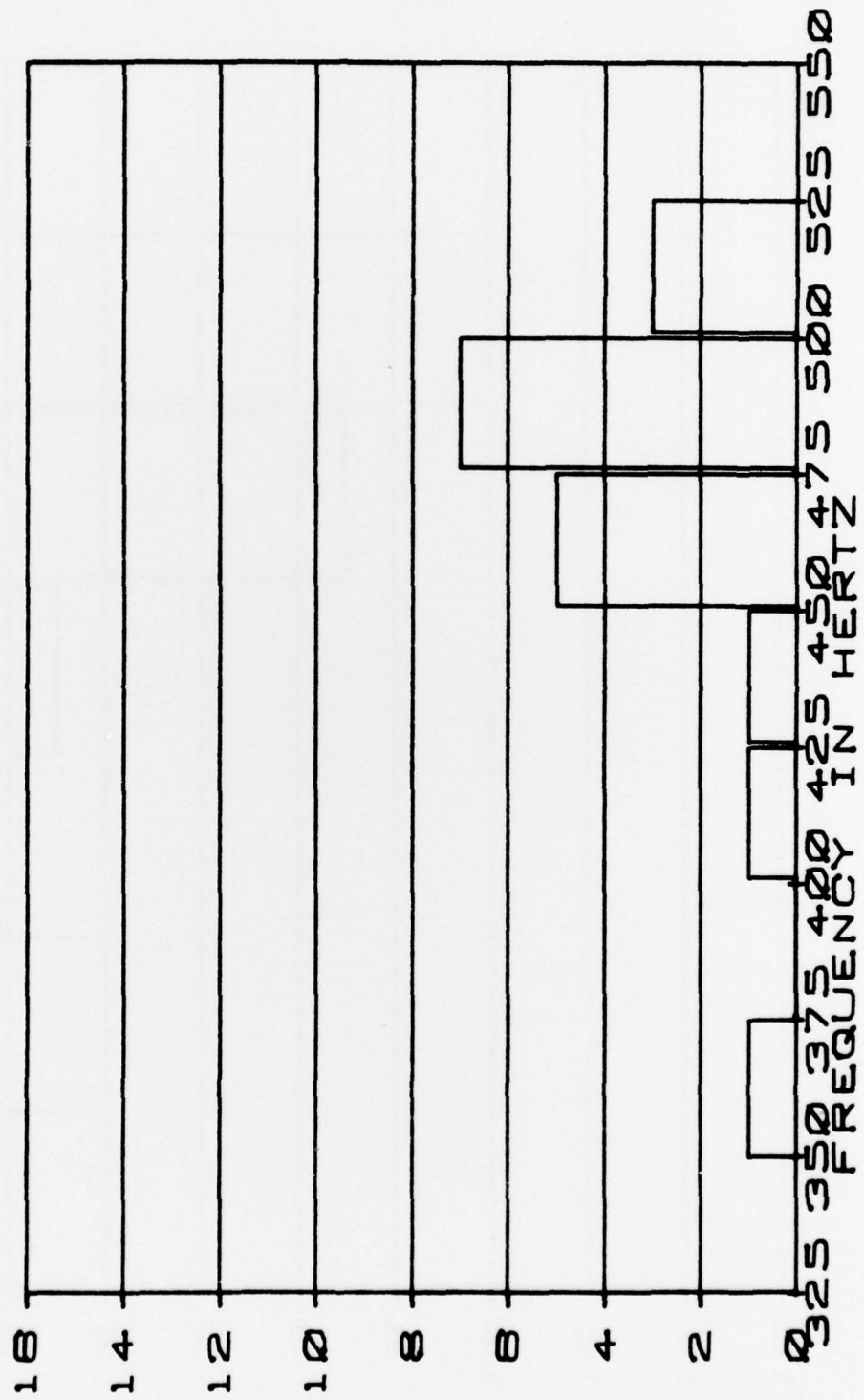

FIGURE B-12 OPERATION DURING VIBRATION AXIS 1

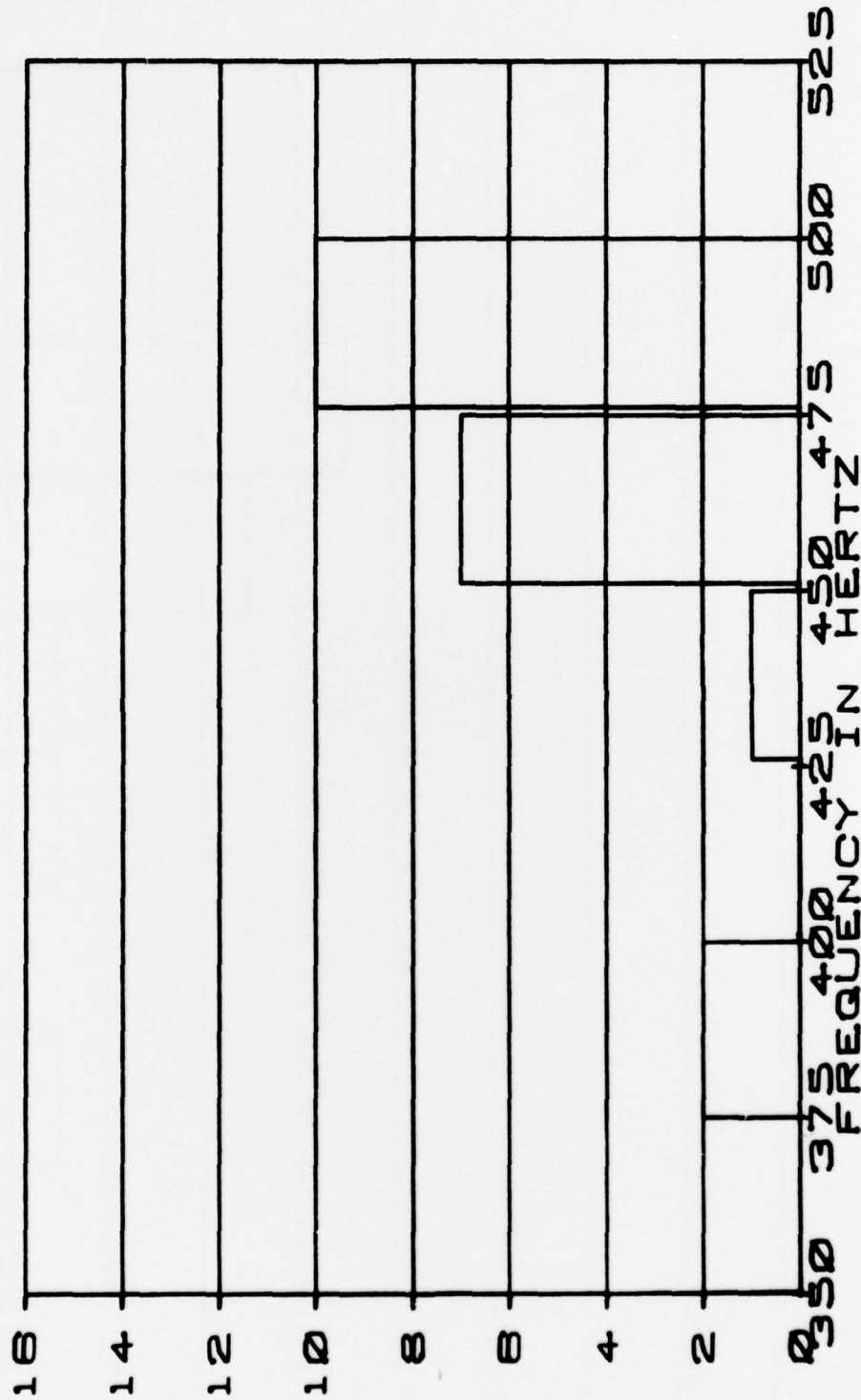

FIGURE B-13 POST VIBRATION BASELINE

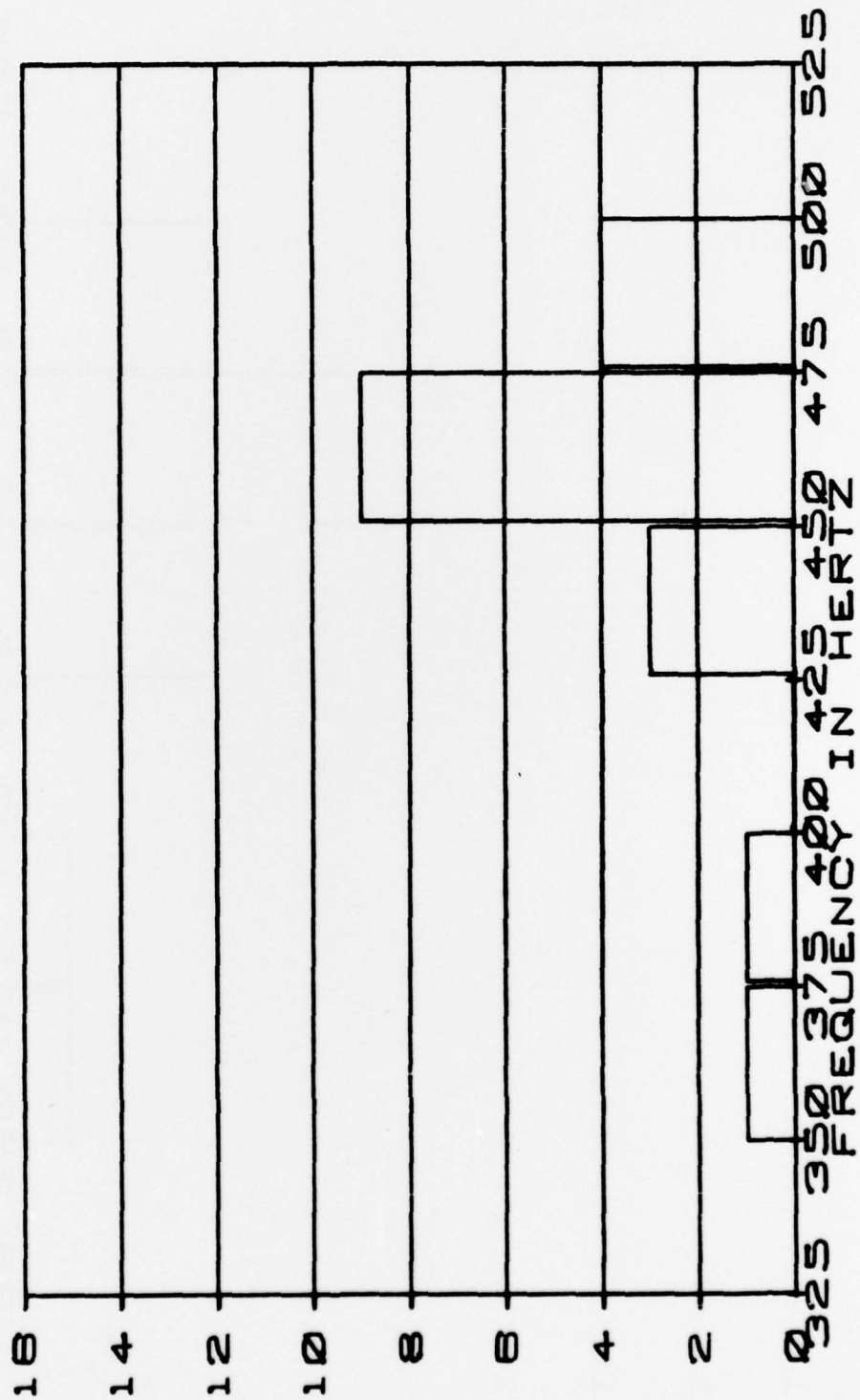

FIGURE B-14 OPERATION DURING ACOUSTIC NOISE TEST

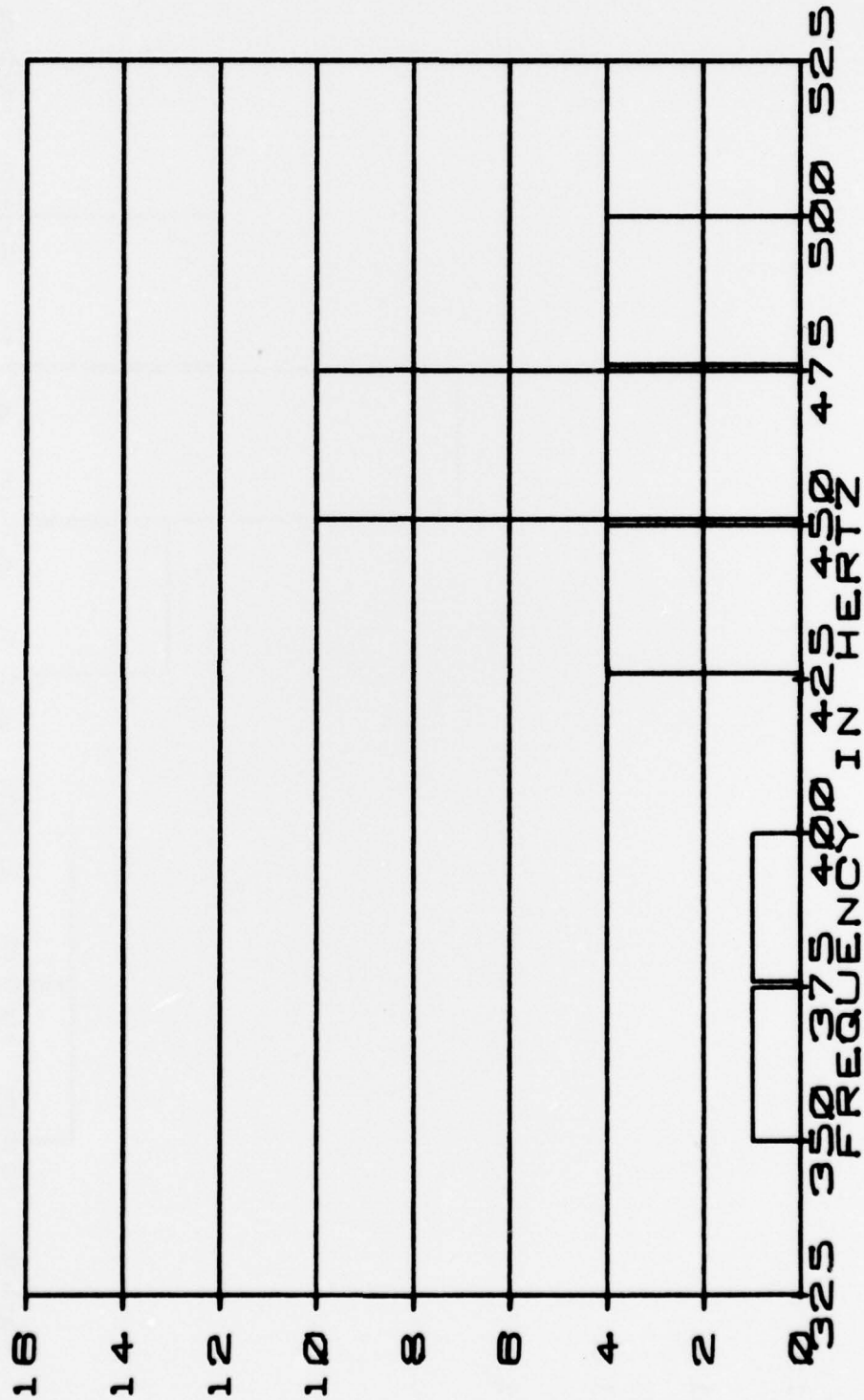

FIGURE B-15 POST ACOUSTIC NOISE BASELINE

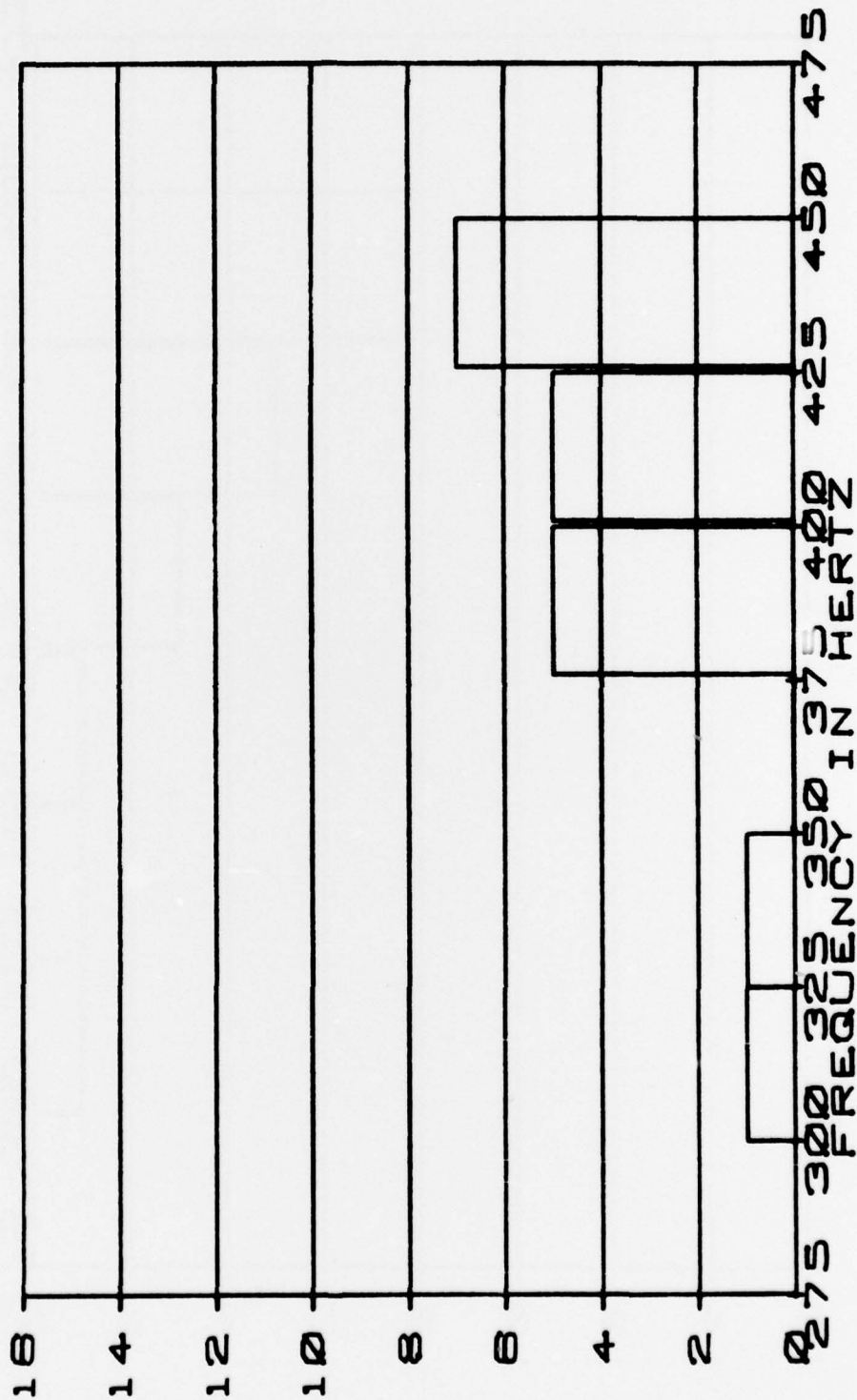

FIGURE B-16 OPERATION AT ALTITUDE 90,000 FT.

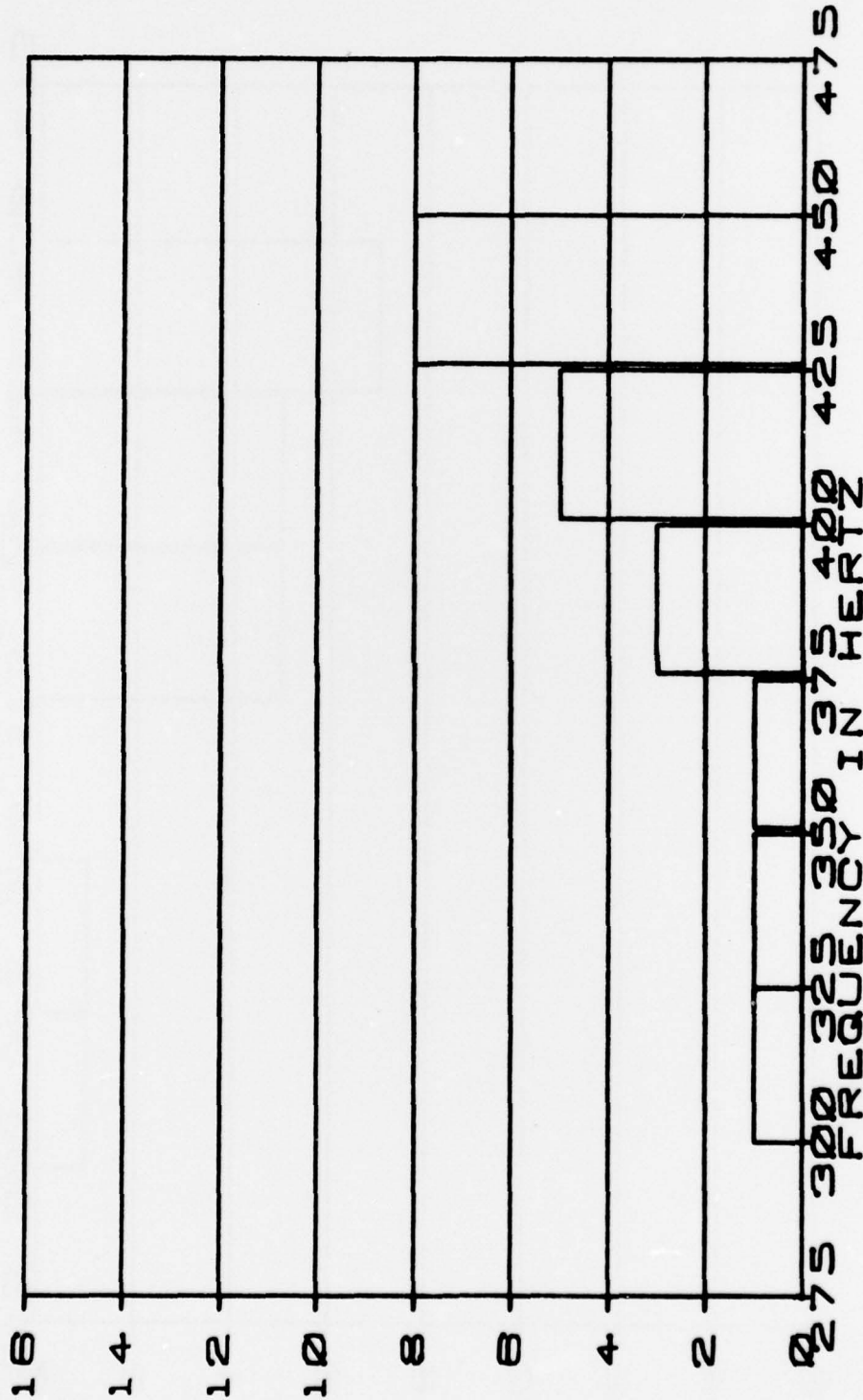

FIGURE B-17 OPERATION AT ALTITUDE 50,000 FT.

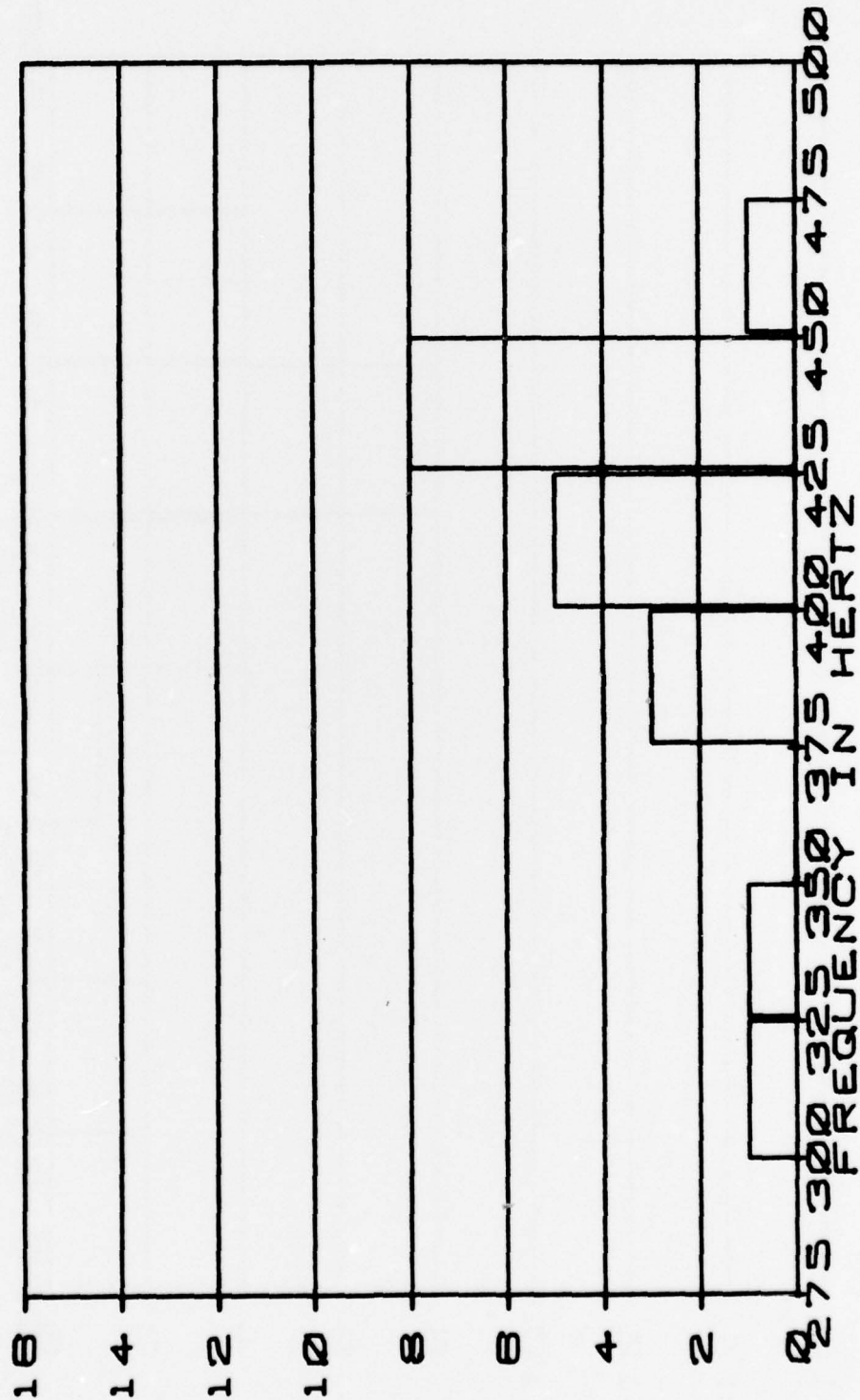

FIGURE B-18 OPERATION AT ALTITUDE 25,000 FT.

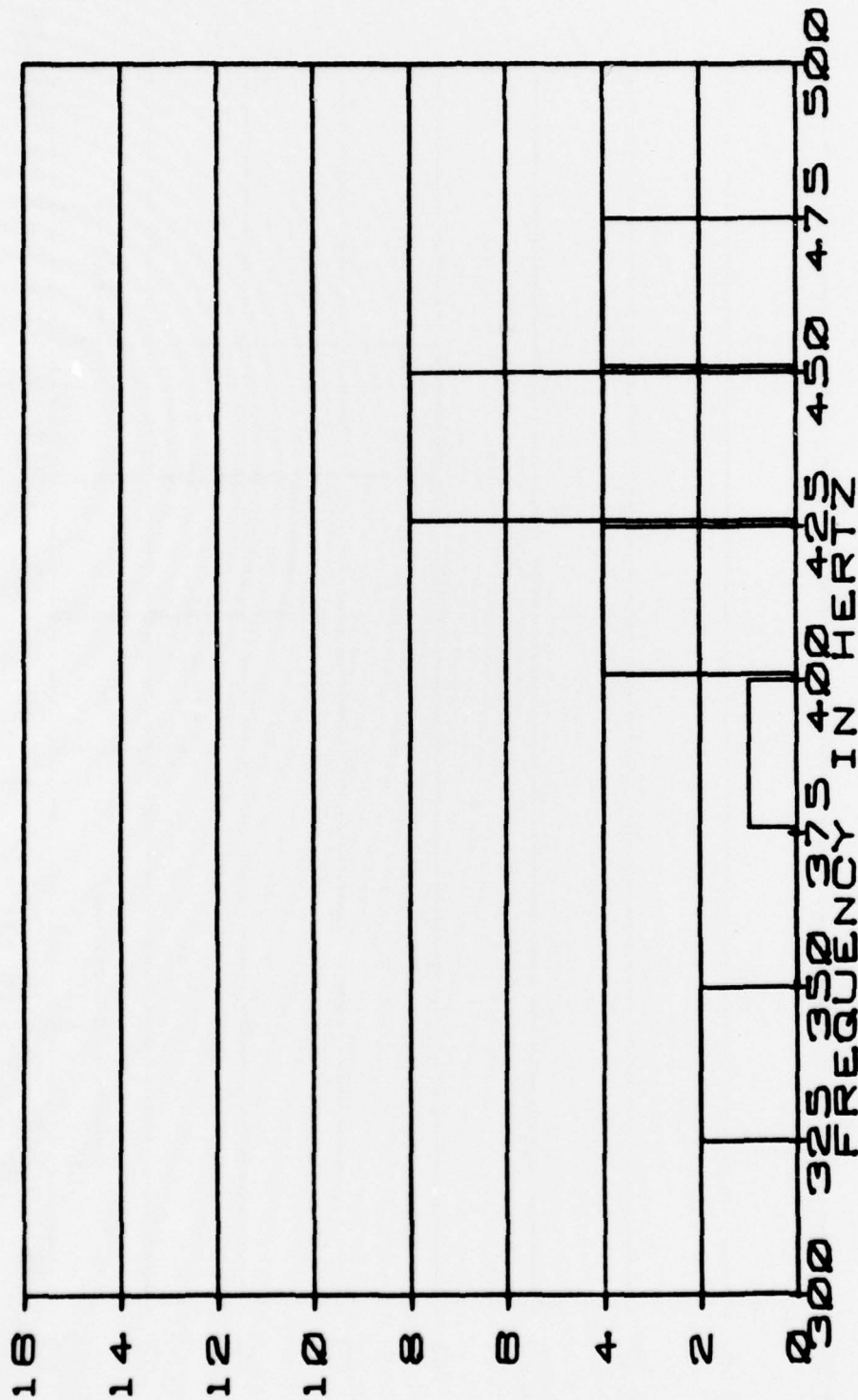

FIGURE B-19 OPERATION AT ALTITUDE 10,000 FT.

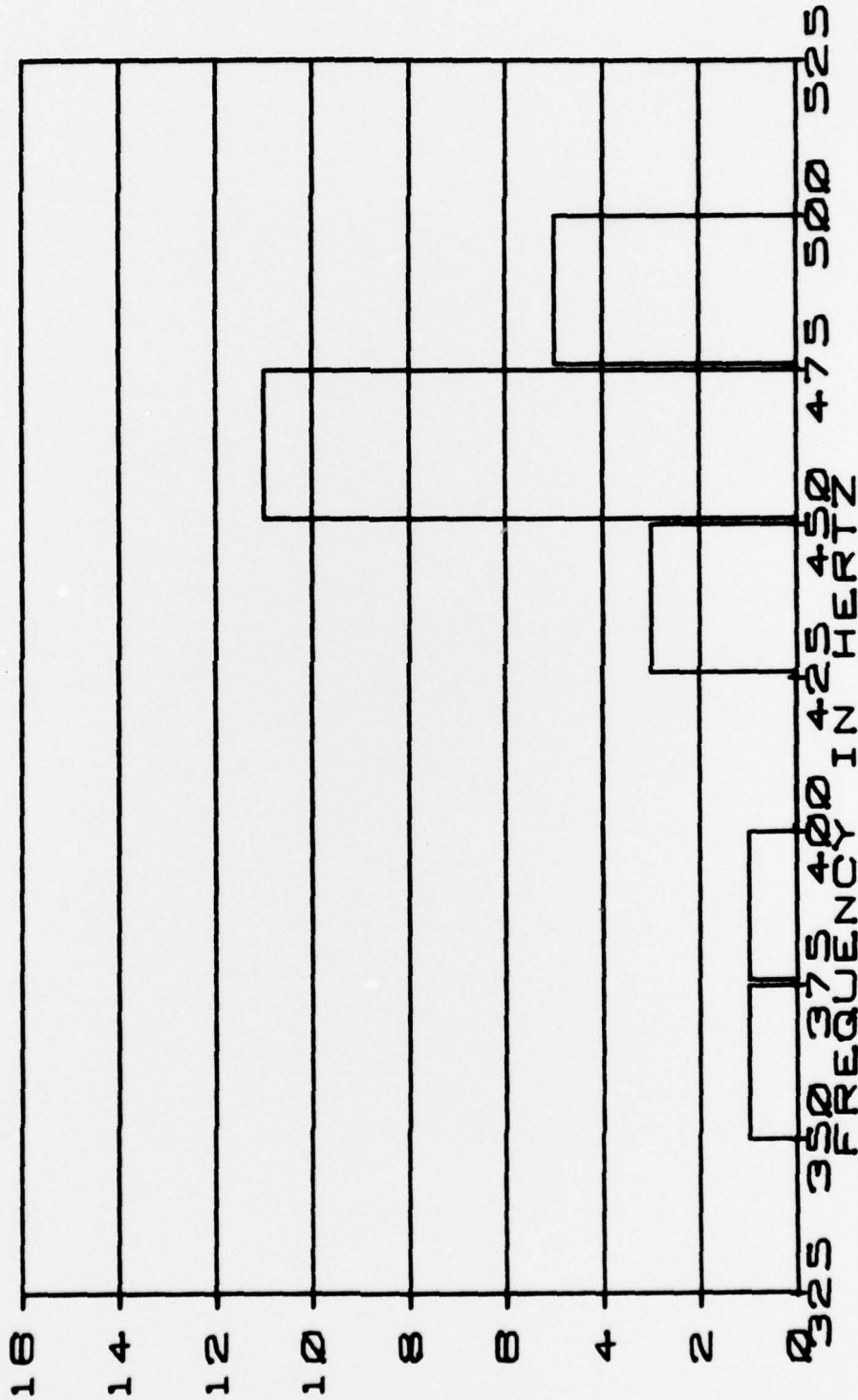

FIGURE B-20 POST ALTITUDE BASELINE

APPENDIX C
DISTRIBUTION LIST

Defense Documentation Center
Cameron Station, Building 5
Alexandria, Virginia 22314
ATTN: DDC-TCA (12 Copies)

Commander
Harry Diamond Laboratories
2800 Powder Mill Rd.
Adelphi, Maryland 20783
ATTN: DRXDO-RCD (4 Copies)
ATTN: DRXDO-TI-013 (1 Copy)
ATTN: DRXDO-TI, HDL Library (3 Copies)

Commander
Picatinny Arsenal
Dover, New Jersey 09801
ATTN: SARPA-ND-C-C (4 Copies)