

**A LASER VELOCIMETER FOR THE AEDC
ACOUSTIC RESEARCH TUNNEL**

**PROPULSION WIND TUNNEL FACILITY
ARNOLD ENGINEERING DEVELOPMENT CENTER
AIR FORCE SYSTEMS COMMAND
ARNOLD AIR FORCE STATION, TENNESSEE 37389**

June 1977

Final Report for Period October 11, 1974 - June 30, 1976

Approved for public release; distribution unlimited.

Prepared for

**DIRECTORATE OF TECHNOLOGY (DY)
ARNOLD ENGINEERING DEVELOPMENT CENTER
ARNOLD AIR FORCE STATION, TENNESSEE 37389**

NOTICES

When U. S. Government drawings specifications, or other data are used for any purpose other than a definitely related Government procurement operation, the Government thereby incurs no responsibility nor any obligation whatsoever, and the fact that the Government may have formulated, furnished, or in any way supplied the said drawings, specifications, or other data, is not to be regarded by implication or otherwise, or in any manner licensing the holder or any other person or corporation, or conveying any rights or permission to manufacture, use, or sell any patented invention that may in any way be related thereto.

Qualified users may obtain copies of this report from the Defense Documentation Center.

References to named commercial products in this report are not to be considered in any sense as an endorsement of the product by the United States Air Force or the Government.

This report has been reviewed by the Information Office (OI) and is releasable to the National Technical Information Service (NTIS). At NTIS, it will be available to the general public, including foreign nations.

APPROVAL STATEMENT

This technical report has been reviewed and is approved for publication.

FOR THE COMMANDER



MARSHALL K. KINGERY
Research & Development
Division
Directorate of Technology

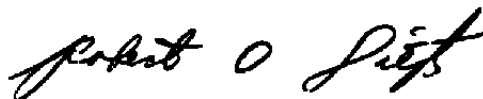

ROBERT O. DIETZ
Director of Technology

UNCLASSIFIED

REPORT DOCUMENTATION PAGE		READ INSTRUCTIONS BEFORE COMPLETING FORM												
1 REPORT NUMBER AEDC-TR-77-53	2 GOVT ACCESSION NO.	3 RECIPIENT'S CATALOG NUMBER												
4 TITLE (and Subtitle) A LASER VELOCIMETER FOR THE AEDC ACOUSTIC RESEARCH TUNNEL		5 TYPE OF REPORT & PERIOD COVERED Final Report - October 11, 1974 - June 30, 1976												
		6. PERFORMING ORG. REPORT NUMBER												
7. AUTHOR(s) V. A. Cline, ARO, Inc.		8. CONTRACT OR GRANT NUMBER(s)												
9 PERFORMING ORGANIZATION NAME AND ADDRESS Arnold Engineering Development Center (DY) Air Force Systems Command Arnold Air Force Station, Tennessee 37389		10. PROGRAM ELEMENT, PROJECT, TASK AREA & WORK UNIT NUMBERS Program Element 65807F												
11. CONTROLLING OFFICE NAME AND ADDRESS Arnold Engineering Development Center (DYFS) Arnold Air Force Station, Tennessee 37389		12. REPORT DATE June 1977												
		13. NUMBER OF PAGES 30												
14 MONITORING AGENCY NAME & ADDRESS (if different from Controlling Office)		15. SECURITY CLASS. (of this report) UNCLASSIFIED												
		15a. DECLASSIFICATION/DOWNGRADING SCHEDULE N/A												
16 DISTRIBUTION STATEMENT (of this Report) Approved for public release; distribution unlimited.														
17. DISTRIBUTION STATEMENT (of the abstract entered in Block 20, if different from Report)														
18 SUPPLEMENTARY NOTES Available in DDC														
19 KEY WORDS (Continue on reverse side if necessary and identify by block number) <table style="width: 100%; border: none;"> <tr> <td style="width: 33%;">laser velocimeters</td> <td style="width: 33%;">angles</td> <td style="width: 33%;">radiation</td> </tr> <tr> <td>measurement</td> <td>turbulence</td> <td>backscattering</td> </tr> <tr> <td>flow</td> <td>intensity</td> <td>particles</td> </tr> <tr> <td>velocity</td> <td>Mach numbers</td> <td></td> </tr> </table>			laser velocimeters	angles	radiation	measurement	turbulence	backscattering	flow	intensity	particles	velocity	Mach numbers	
laser velocimeters	angles	radiation												
measurement	turbulence	backscattering												
flow	intensity	particles												
velocity	Mach numbers													
20 ABSTRACT (Continue on reverse side if necessary and identify by block number) <p>An operational laser velocimeter (LV), installed in the Acoustic Research Tunnel (ART) at the Arnold Engineering Development Center (AEDC), for routine measurement of mean flow velocities, flow angle, and turbulent intensity is described. It is a two-component, dual-scatter, moving-fringe-type system collecting forward-scattered radiation. Basic LV theory and one of the foremost problems of application (particle lag) are discussed in</p>														

UNCLASSIFIED

UNCLASSIFIED

20. ABSTRACT (Continued)

some detail. Test data compared with conventional measurements of velocity and flow angle are shown.

UNCLASSIFIED

PREFACE

The work reported herein was conducted by the Arnold Engineering Development Center (AEDC), Air Force Systems Command (AFSC), under Program Element 65807F. The results were obtained by ARO, Inc., AEDC Division (a Sverdrup Corporation Company), operating contractor for the AEDC, AFSC, Arnold Air Force Station, Tennessee. The work was conducted under ARO Project No. P32S-COA. The author of this report was V. A. Cline, ARO, Inc. The manuscript (ARO Control No. ARO-PWT-TR-77-25) was submitted for publication on April 6, 1977.

CONTENTS

	<u>Page</u>
1.0 INTRODUCTION	5
2.0 THEORY	6
3.0 SYSTEMS DESCRIPTION	
3.1 Optics	10
3.2 Traverse	11
3.3 Component Separation Electronics	12
3.4 Doppler Data Processor - Model 8	13
3.5 Data Acquisition System	14
4.0 DATA ANALYSIS AND SYSTEM ACCURACY	
4.1 Data Reduction	17
5.0 DATA OBTAINED IN ART	18
6.0 RECOMMENDATIONS	26
7.0 SUMMARY	27
REFERENCES	28

ILLUSTRATIONS

Figure

1. Dual-Scatter Interference Fringes	7
2. Schematic of the ART Laser Velocimeter System	10
3. Velocimeter System Frequency Spectrum	13
4. Data Analysis in Accelerating Flow	16
5. Comparison of LV and Tunnel Instrumentation Data	19
6. Percent Discrepancy of \bar{u} from Tunnel Data versus Mach Number	21
7. Profile of Horizontal Velocity	22
8. Flow Angle versus Perturbation Jet Pressure	23
9. Flow Angle Profile	24
10. Repeatability of Horizontal Velocity Measurement	24
11. LV-Obtained Profiles of Mean Velocity, Turbulence, and Shear Stress	25
NOMENCLATURE	29

1.0 INTRODUCTION

A laser velocimeter (LV) system has been installed in the Acoustic Research Tunnel (ART) at the Arnold Engineering Development Center (AEDC). It was designed to provide two orthogonal components of measured mean velocity at any location within the tunnel test section. From the data collections acquired it is also possible to obtain estimates of the flow angle, turbulence intensity, and the Reynolds shear stress. The measurements can be made within 0.010 in. of the model or tunnel wall without disturbing the normal flow pattern.

Throughout the development of the LV technique the technical community has gained information, a little at a time, about the capabilities and potential of this new and quite useful measuring scheme. These bits of information have, in general, come from research reports which were, by nature, isolated in context to the specific parameter under study. Also, the particular parameters were optimized for their own sake, and perhaps the extreme limits were used as selling points for the development program. The potential user of a system might reasonably form all these isolated results into an image of a system which provides the best of each of these parameters simultaneously. Unfortunately, the system design criteria defined by the test requirements, facility geometry, and test conditions demand a system of compromises. For example, the sensitive "probe volume" can be made extremely small by proper manipulation of the optical configuration; however, this value can be far too small to allow processing the resulting signals by conventional-type processor techniques.

The system presented herein is the first one permanently installed in a wind tunnel at the AEDC. For this system, of course, technology was "frozen" at the date of design. Although state-of-the-art techniques consistent with the demands and constraints placed on the system

were used, it is obvious that further improvements in the technology are needed.

The above factors were kept in mind in the preparation of this report. The purpose is not only to formally report the new capabilities in the ART, but to present to the potential user a realistic look at the limitations of this system in particular and the factors involved in the applications of the technique in general.

Limitations which have been noted in this report result in some recommendations for improvements. The necessary steps have been planned to make the instrument a more accurate, useful tool in wind tunnel testing.

2.0 THEORY

The LV technique is based on the familiar Doppler frequency shift which occurs when a wave-emitting source and an observer are moving with respect to each other. In this case, the source is an entrained particle moving with the flow which scatters or reflects the electromagnetic wave (the laser light) toward the observer. The difference in frequency between the scattered light and the unscattered laser light is the Doppler frequency shift from which the velocity of the scattering source is directly determined. A particular geometrical arrangement where light is scattered simultaneously from two input beams is called the "dual-scatter" system, and it has many advantages over the early reference beam systems. Derivation of the equations for scatter source velocity versus the Doppler frequency is found in Ref. 1.

The dual-scatter technique can also be explained by a fringe model showing a fundamental time and distance determination of velocity. As two coherent, monochromatic beams of light are focused to intersect at

some angle (θ), a set of parallel fringes is produced in the region of crossover of the two beams. In Fig. 1, the wave nature of the input beams is indicated by lines perpendicular to the direction of travel, representing the high-intensity crests one wavelength apart. Constructive interference of the two waves produces the fringes, bright where two crests are superimposed, and dark at the superpositions of a crest and a trough. The distance between fringes (δ) is seen from the geometry (Fig. 1b) to be

$$\delta = \lambda / (2 \sin (\theta / 2))$$

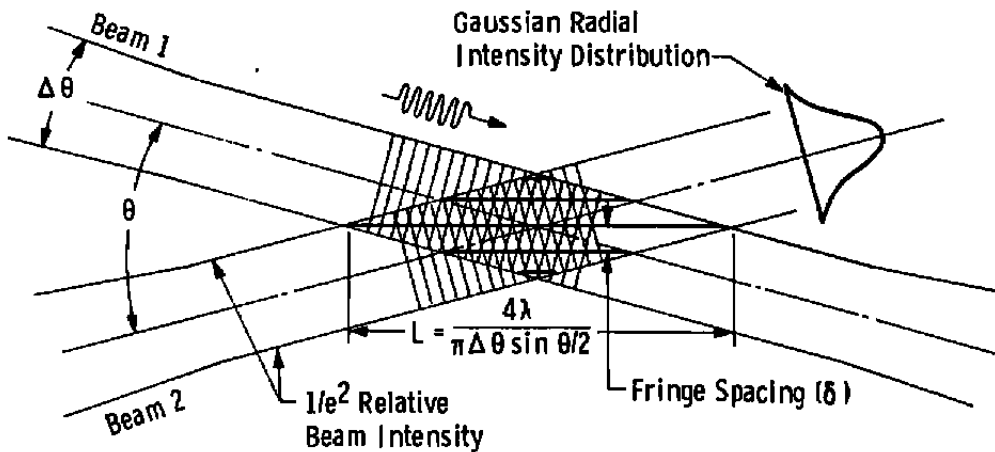

a. Beam crossover region

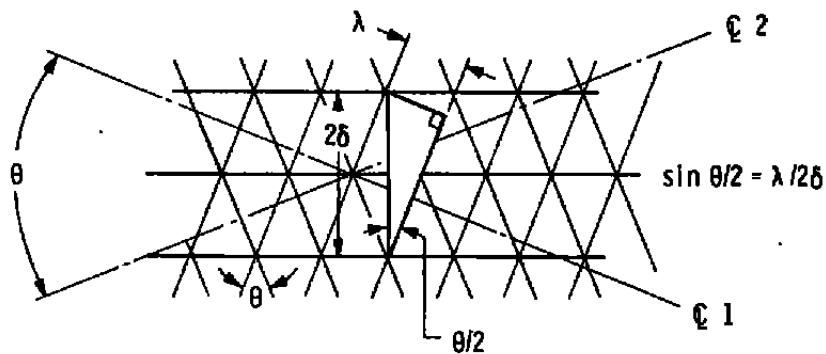

b. Detail of fringe separation

Figure 1. Dual-scatter interference fringes.

A particle moving across the fringe pattern will scatter light with intensity varying proportionally as the fringe pattern intensity. The frequency of the intensity oscillation is directly proportional to the component of the particle velocity normal to the fringes. This scattered light is detected by a photomultiplier tube which provides an output current proportional to the intensity. The period (τ) of this alternating signal is the time required to travel a known distance (the fringe spacing δ). Fundamentally, velocity equals distance divided by time or

$$\bar{v} \cdot \bar{e}_n = \delta/\tau = [\lambda/(2 \sin (\theta/2))] 1/\tau$$

where \bar{e}_n is a unit vector perpendicular to the fringes. Since the signal frequency (f_D) equals $1/\tau$, and the wavelength in a medium of index of refraction n is λ_o/n , then

$$f_D = (2 \sin (\theta/2)/\lambda_o) n \bar{v} \cdot \bar{e}_n$$

which is precisely the equation arrived at using the more rigorous derivation of Ref. 1.

For a given system, the angle between the two beams (θ) is precisely measured and constant. The period of the detected signal is dependent only on velocity and its precise measurement results in a direct measurement of the velocity of the scattering particle.

These stationary fringe patterns are produced by splitting the laser beam by one of several schemes involving glass blocks, prisms or beam-splitting partial mirrors, and focusing the two beams together at the desired beam angle.

The stationary fringe system produces a clean, accurate signal, but has two shortcomings when used in certain flows; (1) the direction of travel of the scattering source is not given, i.e., particles traveling at equal velocity in opposite directions will produce equivalent signals, and (2) particles traveling at small angles with respect to the

fringe planes will not cross enough fringes to produce a processable signal, thereby creating a "dead zone".

To overcome these two problems, a moving-fringe-type system (Bragg cell type) is used. It exploits the interaction of a laser beam with an acoustic wave traveling in a solid or liquid, both to split the beam and to frequency shift one beam with respect to the other (Refs. 2 and 3). This produces fringes moving across the beam crossover region at the frequency of the acoustic wave. Particles traveling against the fringe movement produce a signal frequency greater than the acoustic frequency and vice versa. This solves the directional problem. Also, a particle crossing the region in any direction will be swept by sufficient fringes for processing, thus eliminating the "dead zone".

The previous discussion has described the process for the measurement of a single velocity component normal to the fringe pattern. It is a simple matter to optically provide a second set of fringes orthogonal to those described. A single particle traversing the probe volume will then scatter light from both sets of fringes, thus providing a signal from each set that can be used in making simultaneous, two-component particle velocity measurements.

3.0 SYSTEMS DESCRIPTION

The ART LV is a two-component, dual-scatter, Bragg-cell-type system collecting scattered radiation in the forward-scatter mode. Considerable effort in system design was made to allow "forward-scatter" operation because the intensity of the light scattered in the forward direction (in the direction of the incident beam) is much greater than in the "back-scatter" direction making the system much more sensitive to smaller scatter sources. The moving-fringe-type system was dictated by two considerations: (1) the need to know directionality of flow in the reverse flow regions of experiments such as slotted wall models and

separated boundary-layer studies, and (2) the requirement to measure two components simultaneously.

3.1 OPTICS

A schematic of the system is seen in Fig. 2. The mirrors M_1 through M_5 are used only to fit the geometry of the system to the spatial requirements dictated by the tunnel. The main body of the system is beneath the wind tunnel duct, whereas mirror M_5 , the focusing lens L_3 , and the collection package (L_4 and L_5) are elevated to the level of the test section as indicated by the dotted lines between M_4 and M_5 .

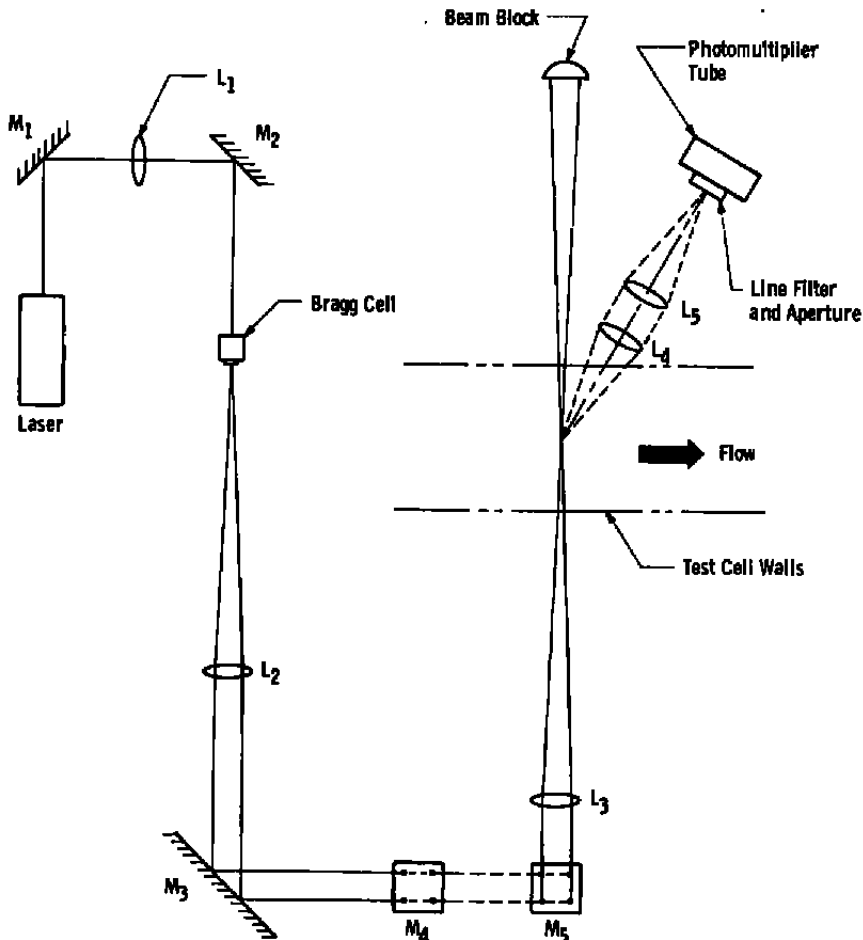

Figure 2. Schematic of the ART laser velocimeter system.

The two-component Bragg cell is used to split the beam into four parts and to shift the frequency of one of the horizontal set by 15 MHz and one beam of the vertical set by 45 MHz. It is arranged so that the fringe planes for the horizontal component move upstream in the tunnel and those for the vertical component move vertically downward. The purpose of lens L_1 is to ensure that the four individual beams come to focus at the point at which the focusing lens L_3 makes them cross. This ensures perfectly parallel fringe planes and helps maintain a small probe volume with sufficient energy density.

The 5-in. lenses, L_4 and L_5 , form the collection package with an f number of 5. Lens L_5 focuses the collected radiation onto an aperture of about 250- μ m diameter. The aperture is used for spatial filtering of the signal to reduce noise input and to control the size of the probe volume.

Upon passing the aperture, the signals go through an optical band-pass filter of about 100- \AA wavelength bandwidth. This also reduces noise input from light sources other than the laser. The signal is then detected and amplified by a photomultiplier tube.

3.2 TRAVERSE

The optics platform is mounted on a three-axis traverse system made from numerical control positioning components. The probe volume can be moved to any predetermined position within the test section to within 0.001-in. accuracy relative to the original reference point. Three digital readouts of position are provided which are recorded on magnetic tape with the data collection.

3.3 COMPONENT SEPARATION ELECTRONICS

The horizontal and vertical components of data are taken at the same time for two reasons. Simultaneous data is preferred when calculating Reynolds shear stress values from the measured turbulence intensity, and a minimum data acquisition time is desired. To accommodate these demands, an electronic scheme is used to separate the signals for processing.

The signal, as detected at the photomultiplier tube, is a complex waveform made up of not only the two desired signal frequencies but also two undesired "crosstalk" frequencies which are the sum and difference of the Doppler-generated signals (Ref. 3). The frequency spectrum, as seen at the photomultiplier tube, is shown in Fig. 3a, giving the bandwidths accommodating the velocity ranges of the instrument. The conventional u is used for horizontal velocity, v for the vertical, and CT for crosstalk. The horizontal velocity information is separated from the rest by the 22-MHz, low-pass filter. It is then processed by the Model 8 Doppler Data Processor (DDP) to be described later.

Three operations take place on the vertical velocity signal. It is first filtered by the 42- to 48-MHz bandpass filter. The remaining signal is then mixed with a crystal-controlled, 65-MHz \pm 0.0002-percent, heterodyne oscillator, and the difference frequency, centered around 20 MHz, is used for processing by a second data processor. This difference spectrum is seen in Fig. 3b. A final bandpass filter (17 to 23 MHz) further aids in eliminating any crosstalk signal from the information band. The signal is processed at 20 MHz rather than at 45 MHz to increase the resolution of the individual measurements.

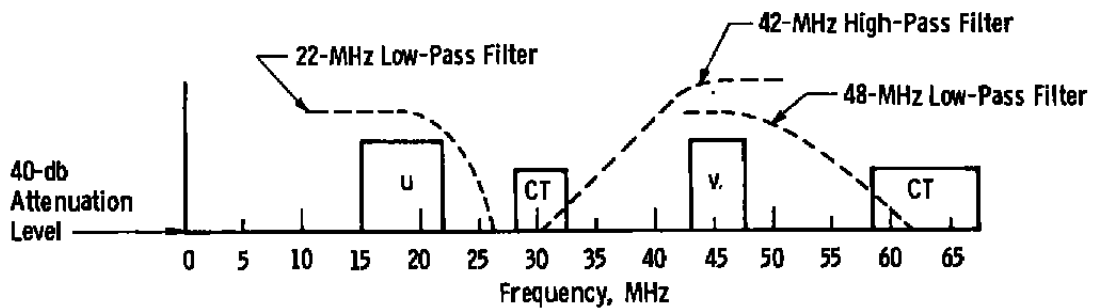

a. At photomultiplier tube

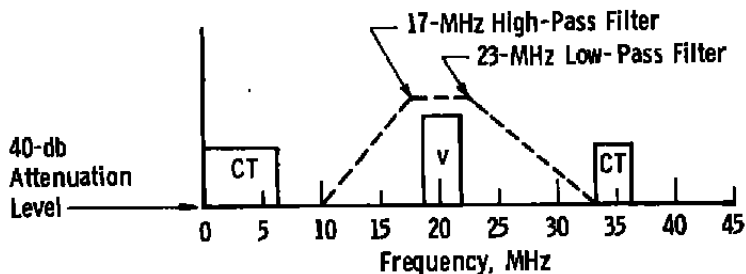

b. Downstream of signal separator

Figure 3. Velocimeter system frequency spectrum.

3.4 DOPPLER DATA PROCESSOR - MODEL B

The data processor developed at the AEDC (described in detail in Ref. 4) samples eight pulse periods of the limited duration "burst" waveform and digitizes the resultant time interval by period counter techniques. A counter is gated "ON" to a crystal-controlled clock at the beginning of one cycle and gated "OFF" at the beginning of the ninth succeeding cycle. The average period of those eight cycles is presented in binary-coded decimal form.

In the presence of poor signal-to-noise ratio, especially with the low-amplitude signals from the smaller entrained particles, severe aberrations of the burst signal waveforms occur. These, in effect, cause "dropout" of one or more pulses of the burst or present an additional pulse caused by a noise spike. The processor logic circuitry

utilizes a unique dual-comparison scheme to reject such data bursts by checking periodicity. It compares the time for both four and five oscillation periods with the time for the eight-cycle period, e.g., the time for eight cycles must be both twice the time for four cycles and eight-fifths the time for five. This highly successful scheme is described in Ref. 4.

3.5 DATA ACQUISITION SYSTEM

A minicomputer is used as the base for the data acquisition system. It has a 32K memory with a data rate capability of 36,000 data sets per second as presently configured. A data set consists of information for both components of velocity and the time of acquisition of that point.

The system takes data into core at the rate defined by the particular flow conditions (i.e., aerosol particle density and local velocity) until a preset number of points are obtained. In most cases, 1,000 points are considered necessary for sufficient accuracy. The mean value of the horizontal and vertical velocity components is displayed within a few seconds, and the original core-stored data are transferred to a nine-track magnetic tape at about 10-kHz word rate. Manual inputs are made to identify each record and other system constants. Three spatial positions are automatically recorded. The data are then available for various forms of reduction on the facility computers.

A line printer provides hard copy of all manual inputs, position, and the mean velocity values at the rate of 100 characters per second.

The capability exists for programming further online data reduction of the measurable parameters. For example, a histogram of the measured velocity distribution could be printed for selected conditions.

4.0 DATA ANALYSIS AND SYSTEM ACCURACY

The Model 8 data processor is capable of measuring the period of well-defined oscillator signals to within 0.5 per cent, or better; however, the burst signal from the LV can be distorted by severe noise in the practical situation, e.g., reflections from window surfaces, etc. Since the noise sources and signal quality can vary significantly, it is impossible to quote a meaningful accuracy applicable to wind tunnel data from laboratory type data, but comparisons with tunnel calibration data and probes to be shown later give a good description of basic system accuracy.

A more significant and perhaps the foremost problem in the application of the LV is the "particle lag problem". As stated earlier, the LV produces a distribution of velocities of the small particles of dust, dirt, condensation, etc., which are entrained in the flow, when in fact, one desires the gas velocity distribution. In many flow situations of interest the two distributions will be identical. However, in regions of large velocity gradients, such as downstream of a shock wave, the inertia of the larger particles does not allow them to immediately adjust to local gas velocity. Therefore, the large, heavy particle will give an erroneous reading in highly accelerating flows. Once again, the amount of error cannot be predicted in advance and is seen in the following analysis to depend on the particle size distribution and basic system parameters.

Consider Fig. 4 where the particle size distribution given for "continental air" (in Ref. 5) is represented as approximately a constant over the radius cubed ($\frac{dN}{dD} = C/r^3$). Each LV system under given conditions will process a signal from all size particles above some minimum shown as point "a" on the figure. Point "b" represents the largest size below which all particles will follow the flow at that location and flow condition. The largest particles entrained is represented at "c". One observes that "a" can vary with signal-to-noise ratio (local window noise, laser power, etc.) and "b" with local flow conditions (velocity

gradients, etc.). If "b" equals "c", all measurements are correct. If $b < a$, none of the measurements is correct. With the assumed distribution if $\int_a^b \frac{dN}{dD} dD > \int_b^c \frac{dN}{dD} dD$, then the majority of the measurements (most frequent values) are correct. In this case, the mode value of the distribution is the best estimator of mean gas velocity. In any case, in highly accelerating flow it is felt to be a better estimate than the mean value.

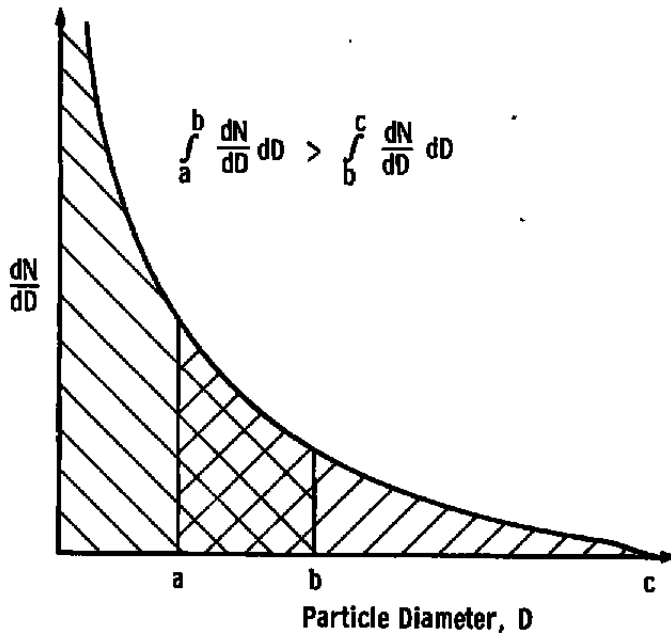

Figure 4. Data analysis in accelerating flow.

To specify the accuracy of this measurement by other than experimental comparisons will require knowledge of the particulate matter normally in the ART flow. These studies are needed but have not been accomplished in the ART. The main particle source may be condensation which could severely modify the assumed c/r^3 size distribution. For the present, accuracy estimates will have to come from experimental comparisons.

4.1 DATA REDUCTION

As seen in Section 2.0, the scatter source velocity is proportional to the Doppler frequency (f_D). When detected at the photomultiplier tube, this is combined with the carrier frequency (Bragg frequency, f_B) and called the processor frequency (f_p)

$$f_p = f_B + f_D$$

the digital output of the data processor is the period (τ) of f_p .

$$f_p = \frac{1}{\tau}$$

the fundamental calculations of the magnitude of the velocity component being measured is then

$$V = Kf_D$$

$$V = K\left(\frac{1}{\tau} - f_B\right)$$

where $K = \frac{\lambda}{2 \sin(\theta/2)}$ from Section 2.0.

The present computer reduction capabilities evolved from the analysis of the particle dynamics problem discussed earlier and from early test data taken in boundary-layer studies and bow shock studies in the Aerodynamic Wind Tunnel (1T). The existing program forms the ensemble collection of reduced velocity data into histogram form. An eighth-order curve fit is applied to the histogram from which the mode value can be found where the slope of the curve goes to zero. The mean value and standard deviation (σ) of the distribution are, of course, calculated also. Options concerning rejection of data deviating by more than 3σ are available.

Visual analysis of the histograms is very helpful in areas of questionable flow characteristics.

5.0 DATA OBTAINED IN ART

Early tests of the instrument revealed signal quality and especially signal quantity far beyond expectations. The off-axis collection system was very effective in providing extremely clean signals despite a sometimes rapid deterioration of window surface quality by dirt and moisture condensation.

Contrary to previous LV experiences where the data acquisition rate was at times less than desirable, records of 1,000 data sets were routinely acquired in less than one second. On occasions, raw data bursts were observed at a rate of more than 1,000,000 per second. Limited number of cycles of a vast majority of these bursts render the conventional data processor incapable of obtaining all this available information. However, this burst rate is very exciting in view of a new Data Analyzer technique which is well under development in the Propulsion Wind Tunnel (PWT)-LV group. A prototype unit described in Ref. 6 was operated during early tests and was successful in taking data from these same signal sources at rates up to 300,000 data points per second. The great potential of these high data rates is in the more direct, more accurate measurement of turbulence intensity. This topic is not completely in the scope of this report, but it is valuable to point out that the existing optics system and tunnel conditions are shown to be capable of supporting this potential breakthrough in turbulence measuring technology.

Shakedown tests of the basic LV system show that very good agreement with tunnel instrumentation is obtained when the mean horizontal velocity component is measured alone; however, the tests also show that when both horizontal and vertical components of data were taken simultaneously there was a greater discrepancy from tunnel instrumentation.

These data sets are shown in Fig. 5. The larger error for data taken simultaneously is believed to be caused by the sharp-roll-off filters in the signal separation electronics package. Upon completion of a thorough study of this problem, it is hoped the additional error will be lessened or that the entire problem will be circumvented. For the present, data are being taken one component at a time.

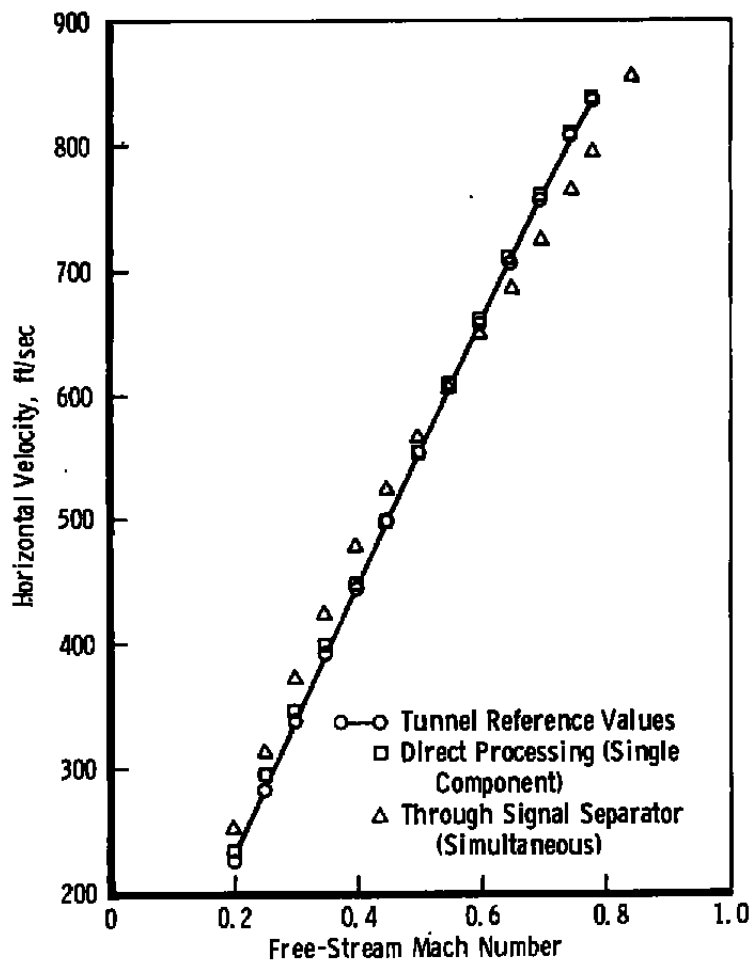

Figure 5. Comparison of LV and tunnel instrumentation data.

Figure 6 shows percent discrepancy from tunnel data versus Mach number for the horizontal component when taken alone. In general, the percent discrepancy would naturally increase near zero reading where one has a finite uncertainty, but there happens to be an additional reason in this case. It is attributed to the requirements dictating the use of the Bragg cell offset frequency. The significance of this trade-off of accuracy for directionality and simultaneous data is seen in an example of a measurement of a nominal 200-ft/sec horizontal velocity. The offset frequency (Bragg cell frequency) is 15 MHz and the nominal Doppler frequency (velocity dependent) is 1 MHz at 200 ft/ sec. From the equations of Section 4.1 the frequency seen by the data processor is therefore the sum of the two and, assuming a measurement accuracy of ± 0.3 percent, the measured frequency would be 16 MHz ± 0.05 MHz. The very accurate crystal-controlled Bragg frequency is subtracted to yield the so-called Doppler frequency

$$\begin{array}{r}
 f_p = 16 \text{ MHz } \pm 0.0500 \text{ MHz} \\
 - f_B = 15 \text{ MHz } \pm 0.0001 \text{ MHz} \\
 \hline
 f_D = 1 \text{ MHz } \pm 0.05 \text{ MHz}
 \end{array}$$

The resultant 0.05 MHz uncertainty is now five percent of the pertinent frequency and therefore five percent of the measured velocity. A curve showing this discrepancy for 0.3-percent accuracy of processor reading throughout the Mach number range is shown in Fig. 6. In this light, the accuracy of the data taken is seen to be quite impressive.

A complete set of tests designed specifically for the shakedown of all the possible applications of the LV has not yet been possible. However, several tests using the mean flow-measuring capability have been accomplished. Selected results of these tests will be presented only for interest of application, with no discussion of the significance of results in an aerodynamic sense.

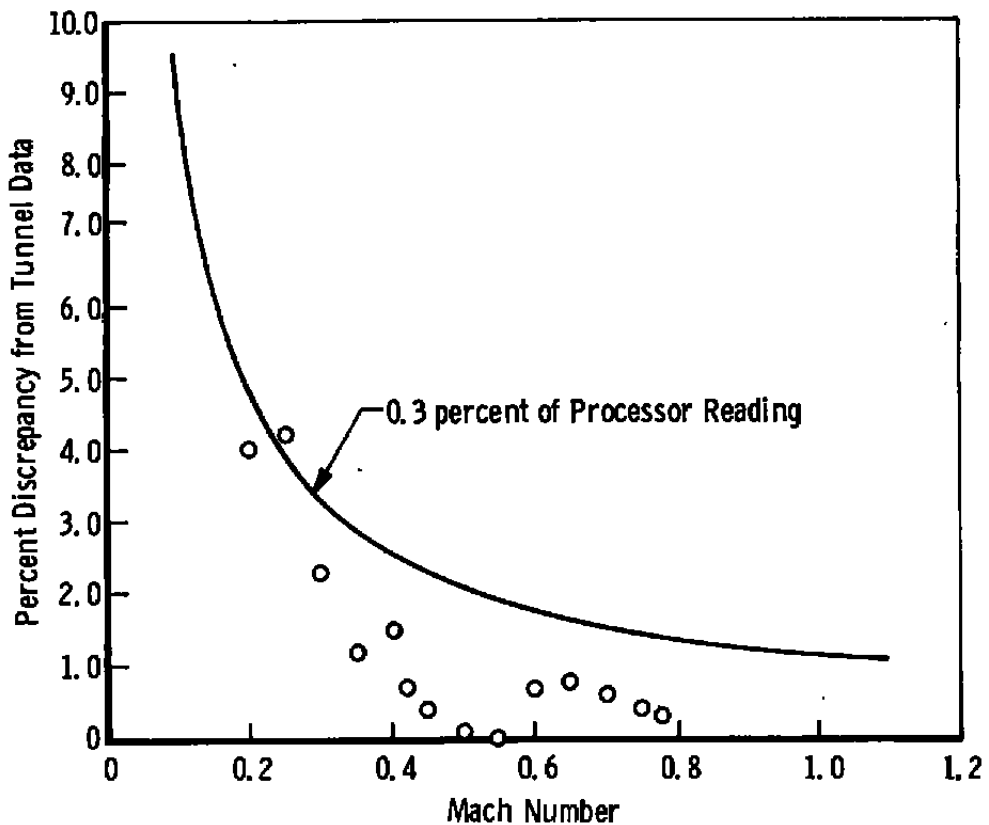

Figure 6. Percent discrepancy of \bar{u} from tunnel data versus Mach number.

The system was used at AEDC to measure velocity profiles in a two-dimensional slot. The reverse flow region below the leading edge of the slot is seen in Fig. 7. Free-stream velocity checked with the tunnel value to within 1.0 percent of reading.

Mean flow angle was obtained with the LV by measuring the mean horizontal velocity component (\bar{u}) singly and then the vertical component (\bar{v}) alone. The angle (α) was calculated by

$$\alpha = \tan^{-1}(\bar{v}/\bar{u})$$

This was done in conjunction with a wind tunnel test which determined gross flow angle changes with various tunnel configurations while introducing perturbations to the flow. Data were taken simultaneously with flow angle probe data while located 0.75 in. in front of the probe tip. Figure 8 shows the comparison with probe data when perturbing crossflow jet pressure was varied from 0 to 60 psi. The agreement in relative angle change is excellent. For the four cases available in this plot, the repeatability of the LV data is in no case worse than ± 0.05 deg. This, of course, includes the repeatability of tunnel and crossjet set points.

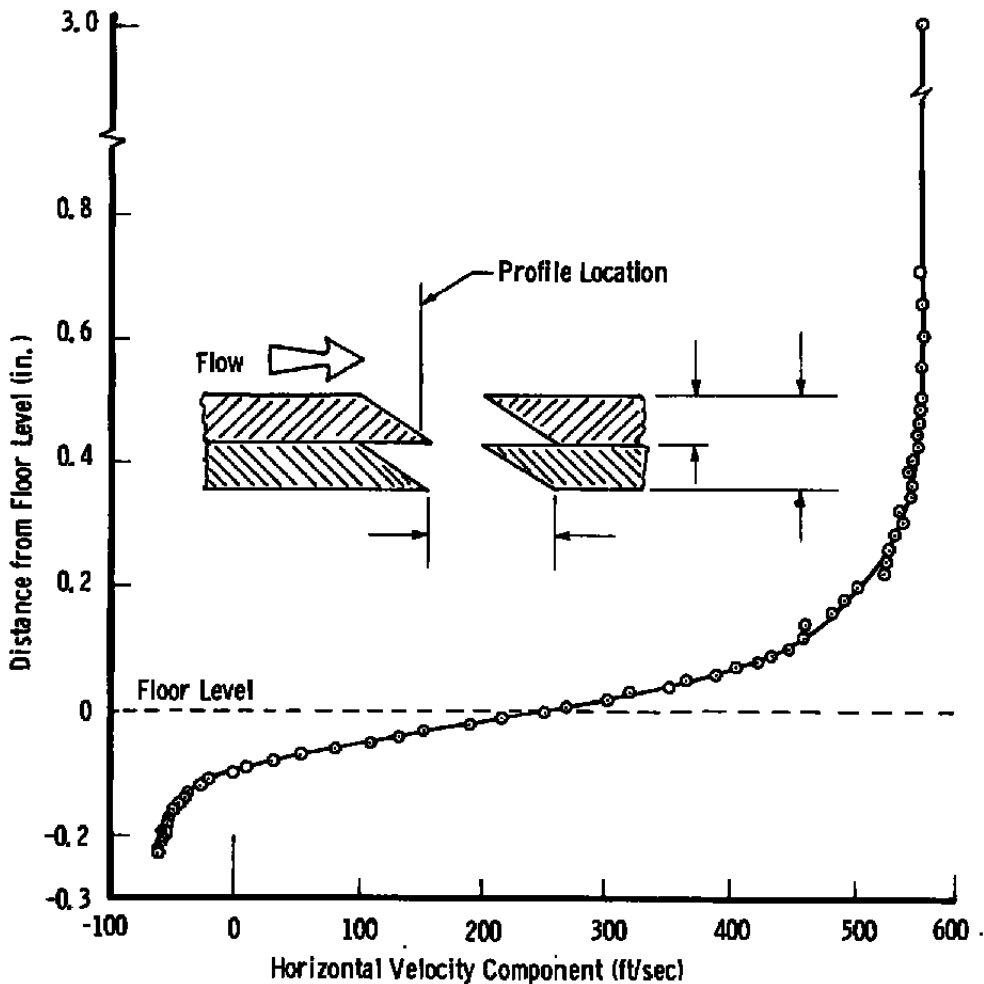

Figure 7. Profile of horizontal velocity.

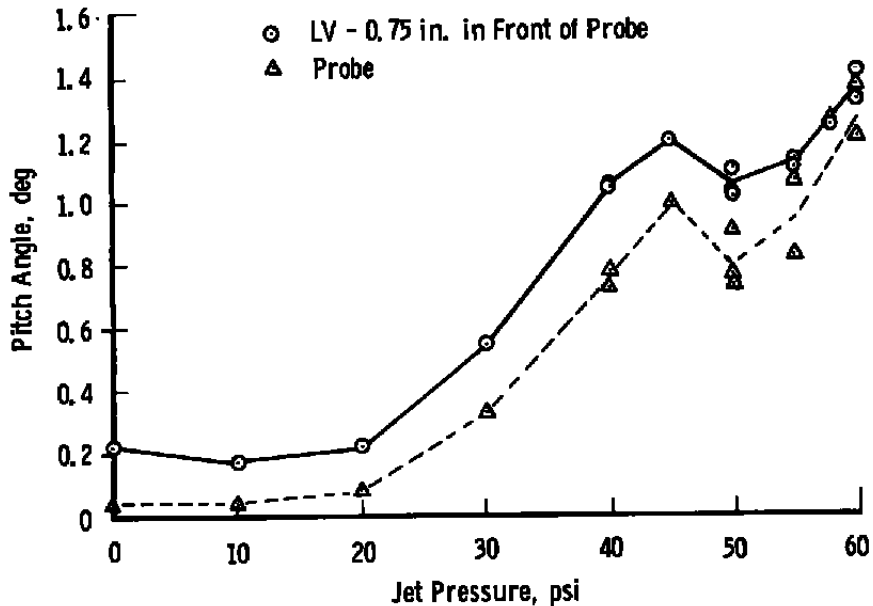

Figure 8. Flow angle versus perturbation jet pressure.

Flow angle profiles such as the one shown in Fig. 9 for Mach No. 0.6 were taken with various tunnel configurations. Again, the relative angle change looked good on each profile. However, the absolute comparison with the probe data varied on different profiles by as much as 0.4 to 0.5 deg. This test could not be conclusive in defining an absolute accuracy because of such things as spatial location differences for the two instruments at which actual flow conditions could be slightly different.

The many measurements of horizontal velocity at a given Mach number during the course of the flow angle tests are plotted in Fig. 10 to indicate LV system repeatability. These data include all measurements taken in the tunnel configuration which was felt most likely to provide the best flow repeatability. Each point on the graph is the result of from 6 to 17 determinations of mean velocity. Most of the data indicate a repeatability of the Tunnel-LV combination of 0.5 percent of reading.

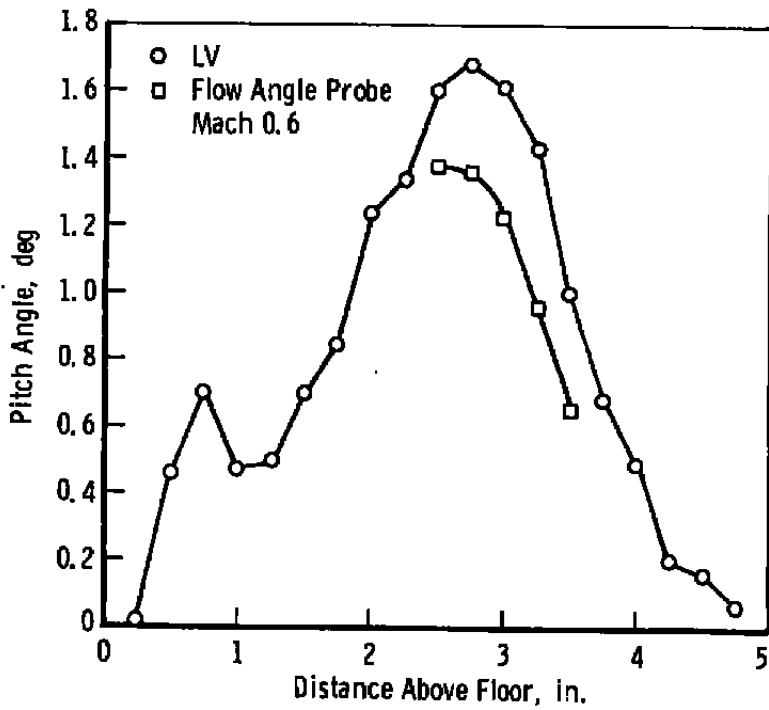

Figure 9. Flow angle profile.

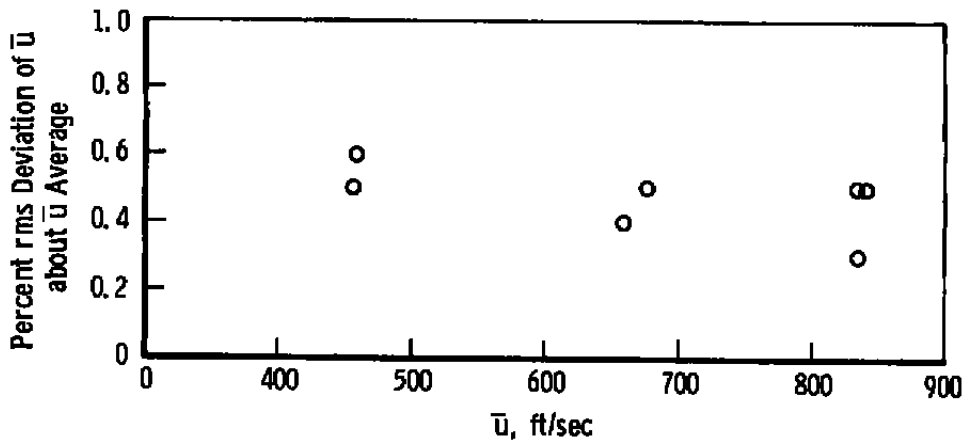

Figure 10. Repeatability of Horizontal velocity measurement.

Figure 11 shows LV data taken in the boundary layer over the bottom wall of a low-disturbance tunnel with velocities normalized to the edge velocity and distance normalized to the boundary-layer thickness. The circles show the mean velocity profile compared with the pitot probe data taken on a different occasion but with equivalent tunnel conditions. The closest proximity to the wall on such LV profiles was typically 0.005 to 0.010 in.

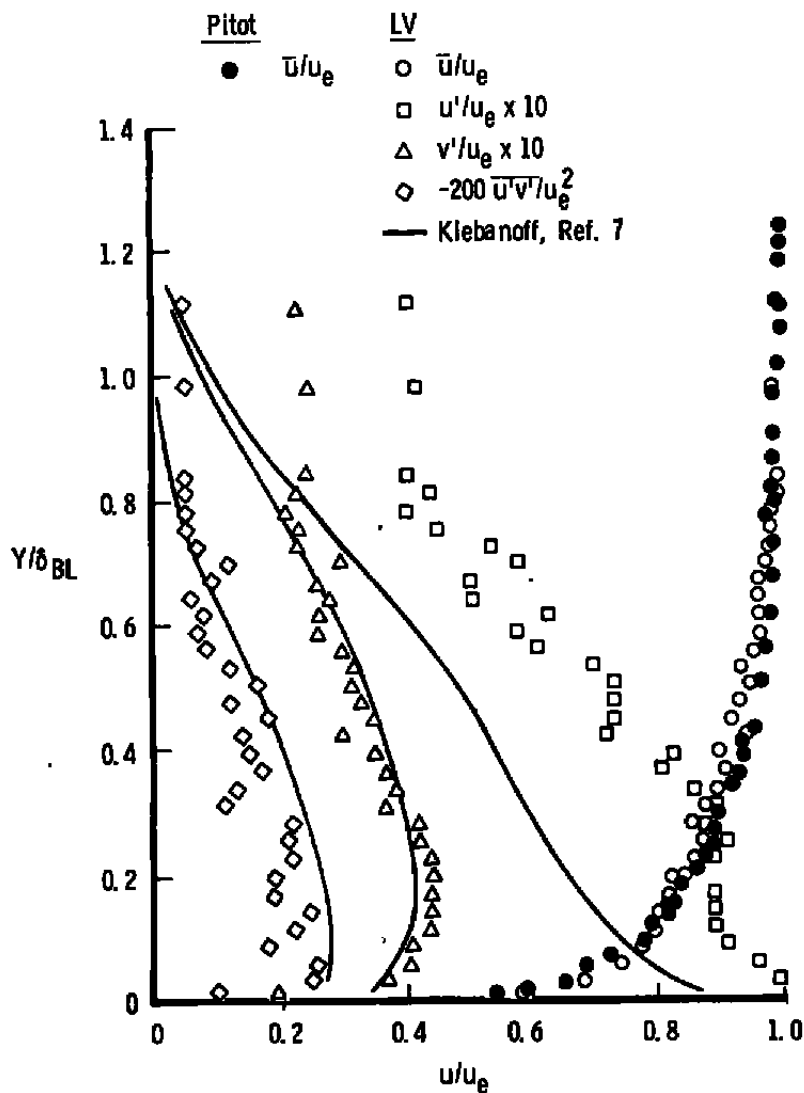

Figure 11. LV-obtained profiles of mean velocity, turbulence, and shear stress.

Indicators of the turbulence levels are also shown by u'/u_e and v'/u_e where u' and v' are the respective standard deviations of the ensemble collection of u and v measurements at a point, and u_e is the edge velocity of the boundary layer. The shear stress is indicated by the plot of $\bar{u}'\bar{v}'/u_e$. Results of early studies by Klebanoff (Ref. 7) using hot-wire anemometry are shown only for a trend comparison. Although the flow in Klebanoff's case was an order of magnitude lower in free-stream velocity and in unit Reynolds number, the shape comparison is reasonable.

The significance of these data is that in the absence of a direct comparison with hot-wire data, the self-consistency of the LV data set is the only check thus far on the turbulence intensity measurements. If the portion of the shear curve which is turbulence dominated is extrapolated to the origin, the value of skin friction obtained (2.5×10^{-3}) compares reasonably well with the value obtained by the "Law of the Wall" from the mean velocity profile (2.8×10^{-3}). This self-consistency of the data set lends confidence to $\bar{u}'\bar{v}'$ and therefore to u' and v' individually.

6.0 RECOMMENDATIONS

Methods or tests must be designed to establish the limits of error on all measurement parameters not already well defined. Particular emphasis should be placed on turbulence intensity measurements where perhaps the best method at present is a comparison with hot-wire data where discrepancy limits are also unclear.

It is apparent from earlier tests that further refinement of the signal separation technique for simultaneous, two-component measurements and the frequency shifting technique for directionality is necessary to allow overall system accuracy which equals that of the fundamental measurement capability of the technique. Consideration should be given to

double shifting of the frequency with solid-state Bragg cells to provide a more stable beam split with a lower frequency shift. This would increase accuracy at low velocities and also ease the signal separation requirements (allow wider band electronic filters) so that the present separation scheme may be satisfactory. If necessary, two-color optic systems could be introduced for component separation.

With the error limits established for the system, confidence has been gained in the measurement of particle velocity. The remaining task is to determine the magnitude of error induced by particle lag in the test conditions of interest. One approach would be to characterize the particulate matter in the flow and analytically establish lag errors. Another would be to design "worst case" situations, such as a bow shock study, to define the maximum lag error for this system with existing particulates.

Further development and adaptation of the Data Analyzer to the current, two-component, LV system is necessary to utilize the very high data rate available in the facility. The significant potential of this technique is a more accurate and direct measurement of turbulence intensity. Also, the small particle capability will aid tremendously in minimizing the particle lag problem.

7.0 SUMMARY

A new capability exists in the AEDC Acoustic Research Tunnel in the form of a permanently installed laser velocimeter. A potential exists for the measurement of mean flow velocity, mean flow angle, turbulence intensity, and Reynolds shear stress. The velocimeter's spatial resolution and data-gathering capability very near a surface make it well suited for boundary-layer studies. Its very mobile and accurate three-dimensional traverse system is much less restrictive, and much faster, in mapping large flow fields than conventional probe positioners.

The available data indicate very accurate mean flow measurements with discrepancies of less than one percent of reading in the tunnel range above Mach No. 0.4. Laser velocimeter system repeatability in one component of measurement at a fixed tunnel set point showed a maximum deviation of 0.6 percent. However, when both components were taken simultaneously, errors on the order of five to ten percent were seen at very low Mach numbers.

REFERENCES

1. Lennert, A. E., Brayton, D. B., and Crosswy, F. L. "Summary Report of the Development of a Laser Velocimeter to Be Used in AEDC Wind Tunnels." AEDC-TR-70-101 (AD871321), July 1970.
2. Mazumder, M. K. "Laser Doppler Velocimeter Measurement without Directional Ambiguity By Using Frequency Shifted Incident Beams." Applied Physics Letters, Vol. 16, No. 11, June 1970, pp. 462-464.
3. Crosswy, F. L. and Hornkohl, J. O. "Signal Conditioning Electronics for a Laser Vector Velocimeter." Review of Scientific Instruments, Vol. 44, No. 9, September 1973, pp. 1324-1332.
4. Kalb, H. T., Brayton, D. B., and McClure, J. A. "Laser Velocimetry Data Processing." AEDC-TR-73-116 (AD766418), September 1973.
5. Handbook of Geophysics and Space Environments. USAF Cambridge Research Laboratory, McGraw Hill, 1965.
6. Kalb, H. T. and Cline, V. A. "New Technique in the Processing and Handling of Laser Velocimeter Burst Data." Review of Scientific Instruments, Vol. 47, No. 6, June 1976.
7. Klebanoff, P. S. "Characteristics of Turbulence in a Boundary Layer with Zero Pressure Gradient." NACA Report No. 1247, 1955.

NOMENCLATURE

C	Constant
D	Particle diameter
\bar{e}_n	Unit vector perpendicular to fringes
f	Frequency
K	Conversion constant
N	Number of particles per unit volume
n	Index of refraction
r	Radius
\bar{u}	Mean horizontal velocity
V	General velocity vector
\bar{v}	Mean vertical velocity
Y	Distance from wall
α	Flow angle
δ	Distance between fringe planes
δ_{BL}	Boundary-layer thickness
λ	Wavelength of laser radiation

θ Angle between input beams

τ Period of signal

SUBSCRIPTS

B Bragg

D Doppler

e Edge value

O Vacuum conditions

P Processor