

AD-A041 014

AERONAUTICAL RESEARCH COUNCIL LONDON (ENGLAND)
EFFECT OF INTERSPERSED PERIODS OF HEATING ON FATIGUE CRACK INIT--ETC(U)
JUL 76 F E KIDDLE

F/G 11/6

UNCLASSIFIED

ARC-CP-1366

NL

ADP
A041014

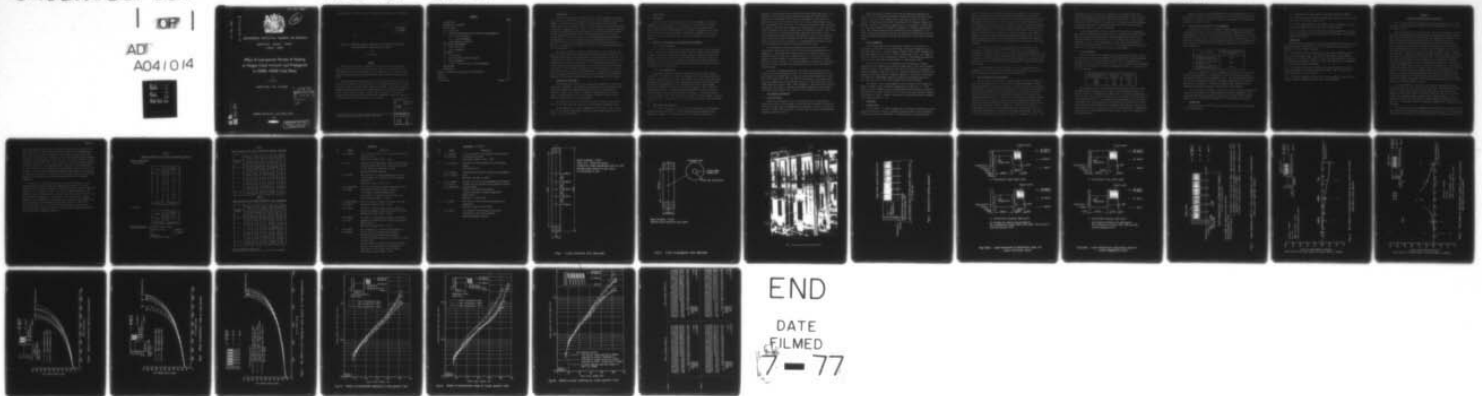

END

DATE
FILMED

7-77

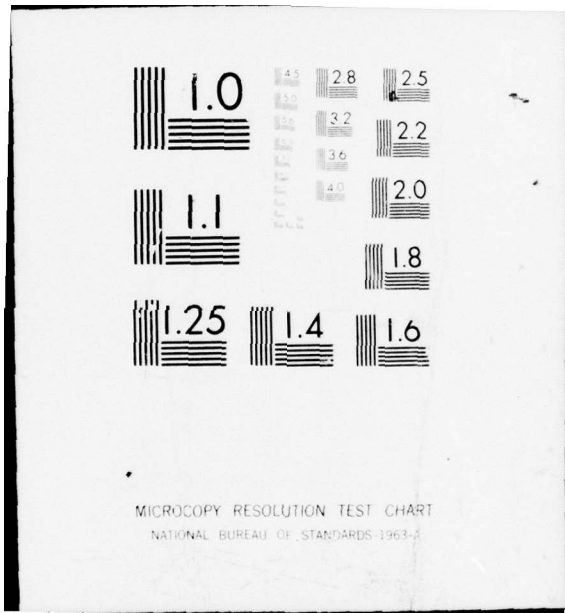

MICROCOPY RESOLUTION TEST CHART
NATIONAL BUREAU OF STANDARDS-1963-A



2

C.P. No. 1366

ADA041014

ACQUISITION EXECUTIVE, MINISTRY OF DEFENCE

AERONAUTICAL RESEARCH COUNCIL

CURRENT PAPERS

Effect of Interspersed Periods of Heating on Fatigue Crack Initiation and Propagation in CM001 (RR58) Clad Sheet

by

F. E. Kiddle

Structures Dept., R.A.E., Farnborough

DDC
RECEIVED
JUN 28 1977
RECEIVED

AD No. _____
DDC FILE COPY

LONDON: HER MAJESTY'S STATIONERY OFFICE

1977

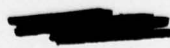

DISTRIBUTION STATEMENT A
Approved for public release;
Distribution Unlimited

14 ARC-CP 1366

*CP No. 1366

11 July 1976

9 Current papers

12 33p.

6 EFFECT OF INTERSPERSED PERIODS OF HEATING ON FATIGUE CRACK INITIATION AND PROPAGATION IN CM001 (RR58) CLAD SHEET

by

10 F. E. Kiddle

SUMMARY

Fatigue tests have been conducted to study the effect of interspersed periods of heating on the initiation and early growth of cracks from holes in clad sheet and also on later stages of crack propagation. The tests were under flight simulation loading and the material was CM001 (RR58) clad aluminium alloy sheet.

Interspersed heating reduced the lives to initiate and grow cracks to 2mm and this is attributed to the softening of strain hardened material at the crack tip, but no effect was observed for longer crack lengths. When load was applied during the periods of heating creep redistribution of local stress retarded the growth of short and long cracks. Further work is underway to investigate fatigue-heat interactions under different load-temperature sequences, other forms of material, and over a wider range of crack lengths.

ACQUISITION FOR	
NTIS	White Section <input checked="" type="checkbox"/>
DIC	Blue Section <input type="checkbox"/>
UNANNOUNCED	<input type="checkbox"/>
JUSTIFICATION	
BY	
DISTRIBUTION AVAILABILITY CODE	
Dist. AVAIL. RPO/AR SPEC.	
A	

* Replaces RAE Technical Report 76092 - ARC 37041.

- 1 -
008450

Handwritten signature

CONTENTS

	<u>Page</u>
1 INTRODUCTION	3
2 MATERIALS AND SPECIMENS	3
3 FATIGUE TESTS	4
3.1 Testing rig	4
3.2 Methods of monitoring crack initiation and propagation	4
3.2.1 Crack initiation	4
3.2.2 Crack propagation	4
3.3 Load-temperature sequences	4
4 TEST RESULTS AND ANALYSIS	5
4.1 Crack initiation	5
4.2 Crack propagation	6
5 DISCUSSION	6
5.1 Previous work	6
5.2 Crack initiation and early growth	7
5.3 Crack propagation	8
5.4 Effect of prior heating on crack propagation	9
6 FURTHER WORK	9
7 CONCLUSIONS	10
Appendix Description and operation of testing rig	11
Tables 1-3	13
References	15
Illustrations	Figures 1-15

1 INTRODUCTION

There is now substantial evidence that the kinetic heating of aluminium alloy aircraft structure has appreciable effects on the accumulation of fatigue damage. It has been shown for example that although the overall fatigue characteristics of an aluminium alloy are little affected by substantial periods of heating at temperatures up to 150°C ¹⁻³, the initiation of fatigue damage can be affected markedly by quite modest exposures due to microstructural changes in the surface condition and also to creep redistribution of local stress concentration⁴⁻⁶. It is believed also that analogous mechanisms operating in the material at the tip of a growing crack were responsible for effects observed^{7,8} when tests on riveted joint specimens were interrupted by many periods of heating, since the majority of the life of these specimens was spent in crack propagation.

This report describes a number of investigations of the initiation and growth of fatigue cracks in clad aluminium alloy sheet under a sequence of load and temperature changes simulating flight by flight variations in service. It is shown that the effects of heating were consistent with the occurrence of two mechanisms of fatigue-heat interaction. It is postulated that during each heating period strain hardened material at the crack tip was softened leading to increases in crack growth rate, and that the redistribution of local stress at crack tips tended to reduce crack growth rate. Further work is described which investigates fatigue-heat interactions under different load-temperature sequences, other forms of material, and over a wider range of crack lengths.

2 MATERIALS AND SPECIMENS

The material was Al 2% Cu alloy to specification CM001-1F in the form of clad sheet, 1.6mm thick. This material is particular to the Concorde aircraft and is a development of RR58 aluminium alloy in the fully heat treated condition. Table 1 gives details of chemical composition and the average tensile strength based on 22 tests of specimens extracted from the various sheets of material used in the investigation.

The specimen used for crack initiation tests is shown in Fig.1 and has five test sections along the centre line of the specimen designated A to E.

The specimen used for crack propagation tests is shown in Fig.2 and has only one test section containing a drilled hole with spark eroded slots each side to act as crack starters.

3 FATIGUE TESTS

3.1 Testing rig

The function of the testing rig was to apply a programme of load and temperature to the specimens. The rig applied the same mechanical loads to six specimens simultaneously, but each specimen was heated independently. Axial loads were applied using hydraulic jacks and the temperature was varied by electric fire bar radiant heaters. The general arrangement of the rig is shown in Fig.3; a description of the rig and its operation is given in the Appendix.

3.2 Methods of monitoring crack initiation and propagation

3.2.1 Crack initiation

All cracks were detected and monitored using an optical travelling microscope. With the test stopped and the peak steady load applied it was possible to detect cracks smaller than 1mm in length within an accuracy of 0.2mm. The growth of the cracks were monitored every 200 flight cycles until they were 2.5mm long, at which stage the specimen was repaired with a patch bolted over the test section to prevent rupture which would affect the initiation or growth of cracks at other test sections.

3.2.2 Crack propagation

Cracks were measured at intervals throughout the test using a replica technique⁹. The method is to obtain an impression of the specimen surface on a cellulose acetate sheet and measure crack lengths from it by optical microscope. The impression is obtained by first softening the surface of the acetate sheet with acetone and applying it to the specimen surface under light pressure. After about 3 minutes the surface of the acetate hardens to form a replica of the specimen surface. Cardrick and Gardiner showed⁹ that cracks as short as 20µm in length could be detected using this technique. In the work reported here, the length of the crack was measured accurately to within 0.05mm. Replicas of the crack were taken during the test at intervals not greater than 100 flight cycles.

3.3 Load-temperature sequences

All fatigue loading was a flight by flight representation of ground-air-ground loads and gust loads. For tests with heating the generalised load-temperature sequence is illustrated in Fig.4; it should be noted that to

economise on testing time heat was applied only every sixth flight cycle. The heating up of the aircraft surface during each supersonic flight induces a thermal stress cycle which in the tests was represented by the mechanical reduction of the level of tensile stress. Two cases of thermal stress relief were investigated. The first case, referred to as Intermittent Creep, represents the surface of shallow structure where the thermal stress is of short duration; a typical example of the test loading used is illustrated in Fig.5a. The second case, referred to as Intermittent Heating, represents the surface of deep structure where the steady tension is substantially relieved for the duration of the cruise; Fig.5b shows an example of the test loading in which stress is relieved to zero for the cruise period. No representation was made in either case of thermal stress during the cooling phase of the cruise.

The Intermittent Creep and Intermittent Heating flight cycles are illustrated in Figs.5 and 6 for crack initiation and crack propagation tests respectively. Load-temperature sequences for the two types of tests are nominally identical except for a slight difference in the stage of the load sequence at which heating of the specimen commenced. A third form of load sequence was used (see Fig.7) for crack propagation tests aimed at establishing the effect of prior heating on the subsequent growth of cracks under ambient fatigue loading.

The range of maximum temperatures of heating cycles differed in crack initiation and crack propagation tests. For crack initiation tests each test section within a specimen was at a different temperature; temperatures studied were 150°C, 125°C, 100°C, 70°C and 54°C at test sections A to E respectively. In crack propagation tests each specimen had only one test section, and three temperatures were studied, 130°C, 100°C and ambient. These particular elevated temperatures were chosen to represent the maximum temperatures encountered in the Concorde Major Fatigue Test (130°C) and in the service aircraft (100°C).

4 TEST RESULTS AND ANALYSIS

4.1 Crack initiation

There is a difficulty in all crack initiation tests in selecting an identifiable stage of fatigue damage to represent the conclusion of initiation. In these tests the stage of damage chosen to determine the end of test was the presence of a 2mm crack on one face, at which stage the crack was approximately straight through the section.

Results are given in Tables 2 and 3 and are presented graphically in Figs.8 and 9 for Intermittent Heating and Intermittent Creep conditions respectively. A few tests were stopped before cracks had initiated in order to curtail testing time; these results are indicated in the relevant tables and figures. In order to obtain a log mean value for the number of flight cycles to a 2mm crack, Lariviere's method¹⁰ of allowing for 'unbroken' specimens was used. This method assumes that the distribution of the 'endurances' is log normal and provides scaling factors for the mean and standard deviation of the cracked specimens depending on the observed proportion of tests which developed cracks.

4.2 Crack propagation

For crack propagation tests, specimens contained a crack starter as illustrated in Fig.2 and in all cases fatigue crack growth commenced in less than 100 flight cycles. As this number of flight cycles is small compared with the number applied to end of test - 4600 to 8250 flight cycles - the number of cycles to initiation were not deducted in analysis. Crack growth was monitored until the tip to tip length reached 100mm, i.e. 40% specimen width.

To test the effect of prior heating on crack propagation at ambient temperature, some specimens were heated for 3000 hours at 130°C with and without an applied stress - the temperature, time and stress values were estimated to produce a permanent creep strain of 0.1%. Further specimens had the same stress applied for 3000 hours whilst at ambient temperature. An overall creep strain of 0.068% over a 100mm gauge length was observed for specimens subjected to heat and stress but in other cases permanent strain was negligible.

The results of all crack propagation tests in terms of crack length and number of flight cycles are presented graphically in Figs.10 to 12. Crack growth rates were computed using a program developed by McCartney and Cooper¹¹; this method uses spline functions to fit a curve to the data and hence calculate the growth rate curves. Computed crack rates are presented graphically against crack length in Figs.13 to 15.

5 DISCUSSION

5.1 Previous work

Earlier work⁴⁻⁶ on simple fatigue-heat interactions in various structural elements established two basic mechanisms: machined surfaces were softened by heating and became more susceptible to fatigue and also the redistribution of

stress concentration by creep modified the fatigue behaviour. In the first case it was shown that strain-hardened material at machined surfaces was appreciably altered by heating exposures of a few hours duration; after heating the work affected surface layer contained a coarse secondary precipitate and its hardness was reduced to a value comparable to that of the interior material. This softening effect made the material more vulnerable to subsequent fatigue at ambient temperature. In the case of stress redistribution by creep, it was shown that during periods of heating of a few hours duration, local stress at geometrical stress concentrations was appreciably reduced by creep. The subsequent fatigue performance at ambient temperature was shown to be improved or reduced depending on the local stress being less or more tensile than before heating.

On the basis of this work which was primarily concerned with crack initiation, it has been postulated^{5,7,8,12} that these basic mechanisms of fatigue-heat interactions have their counterparts during crack propagation. The interruption of ambient fatigue loading by heating periods may affect the volume of material ahead of the advancing crack both by changes in the residual stress pattern and also by softening the strain hardened material generated during the cold cycling.

In the following sections the results of crack initiation and crack propagation tests under Intermittent Heating and Intermittent Creep conditions will be discussed in relation to the above considerations.

5.2 Crack initiation and early growth

For all crack initiation tests, cracking commenced in the cladding layer. This layer being relatively soft and unable to support appreciable residual stress was unlikely to be affected by heat. Once the initial crack reached the core material it is possible, as postulated in the last section, that softening and creep redistribution may have had some effect on the volume of material ahead of the advancing crack. Fig.8 presents graphically the results from Intermittent Heating tests. In these tests any relaxation of residual compression which may have occurred at the crack tip during heating would have been ineffectual because heating was always followed by application of peak stress which would restore the residual compression. However the occurrence of softening at the crack tip is indicated perhaps by the reduction in the life to a 2mm crack length which was observed at the higher temperatures. The effect is not very pronounced as the greatest reduction in average life is 20%. It is

interesting to note that there is a tendency for a decrease in life with increasing temperature above 100°C suggesting that softening at the crack tip during each heating period did not reach a saturation level. This contrasts with earlier work³⁻⁵ where it was shown that the decrease in life from surface softening was constant for temperatures above 100°C when similar periods of heating were applied once prior to fatigue.

In Fig.9 comparable results are presented in which heat was applied at peak stress (Intermittent Creep tests) and it is seen that the crack lives are generally improved by heating and are therefore greater than those in the Intermittent Heating tests of Fig.8. It is considered that this relative improvement is due to creep redistribution at the crack tip which gives an increased residual compressive stress. It is not understood why the beneficial effect of this residual stress is so large at around 100°C.

5.3 Crack propagation

The results from crack propagation tests are presented in Figs.10 and 11 for Intermittent Heating and Intermittent Creep respectively and corresponding crack growth rate data are presented in Figs.13 and 14. The magnitude of heating effects are more easily appreciated if lives to 100mm crack are expressed as a ratio to the mean life for the room temperature tests, i.e. Life Ratios in the following table.

Maximum temperature of heating cycle	Intermittent heating	Intermittent creep
20°C	1.00	1.00
100°C	1.01	1.17
130°C	0.99	1.18

These figures indicate that Intermittent Heating has no effect on macro-cracking and that Intermittent Creep tends to reduce crack growth rate, but that the reduction is independent of temperature. The results are generally in line with those for the crack initiation tests except that in this case there is no softening effect at all. No explanation can be afforded for the absence of a softening effect beyond saying that softening would be ineffective if crack advance between heating periods was considerably larger than the extent of the cyclically worked zone at the crack tip at the time of heating. At present the situation has not proved amenable to analysis due in part to the complexity of the loading sequence.

The effectiveness of creep redistribution is not so restricted as it is not confined to the cyclically worked zone; it is not surprising therefore that crack rate was reduced over the whole range of crack length in the Intermittent Creep tests at 100°C and 130°C.

5.4 Effect of prior heating on crack propagation

As mentioned in section 4.2 a number of crack propagation tests were made to determine the possible effects of prior heating on fatigue crack growth at room temperature. Three prior conditions were studied: 3000 hours at 130°C with and without applied stress and 3000 hours at 20°C with an applied stress. Crack growth and crack growth rate data are presented in Figs.12 and 15 respectively. It is seen from the table below that lives to a 100mm crack are similar for all prior conditions.

Prior conditions	Number of flight cycles to 100mm crack
3000 hours at 20°C with 175.5MN/m ² applied stress	4845
3000 hours at 130°C with no applied stress	4895
3000 hours at 130°C with 175.5MN/m ² applied stress	4850

This result suggests that crack propagation is insensitive to quite substantial prior exposures to a temperature of 130°C and a stress in excess of that applied during the crack propagation tests. This provides some assurance that the crack propagation measured in Intermittent Heating and Intermittent Creep tests is relevant to a structural situation where the material has experienced considerable exposure to heat before a crack appears.

It will be seen, incidentally, that the lives in the table are appreciably less than those obtained for crack propagation at ambient temperature in the Intermittent Heating and Intermittent Creep tests described earlier (compare Figs.10 to 12). This has been attributed¹³ to the omission of load dwells.

6 FURTHER WORK

Further series of tests¹⁴ are now proceeding to extend the investigation in the following ways:

- (a) Measurements of crack growth from 0.05mm to 2mm crack lengths.
- (b) Increased frequency of heat interspersion from once every six flight cycles to once every two flight cycles.
- (c) Closer representation of the flight cycle of a supersonic transport aircraft by simulating various patterns of thermal stress.
- (d) The testing of three further forms of RR58 aluminium alloy, unclad sheet, machined plate, and a stretched form of clad sheet, to study their comparative behaviour.

7 CONCLUSIONS

The following conclusions were reached from a study of the effect of interspersed heating at temperatures up to 150°C on fatigue crack initiation and propagation in CM001 (RR58) clad sheet.

- (1) Interspersed heating at nominally zero load caused a slight decrease in life to a crack length of 2mm. This effect is attributed to the repeated softening of cyclically worked material at the crack tip and tends to increase with increasing temperature. However no effect was observed on the propagation of cracks between 20mm and 100mm long.
- (2) Interspersed heating under steady tension caused retardation in crack growth for lengths up to 2mm and from 20mm to 100mm. This is attributed to creep redistribution of local stress.
- (3) A substantial exposure to heat, with or without applied stress, prior to fatigue at ambient temperature had no effect on crack growth.

AppendixDESCRIPTION AND OPERATION OF TESTING RIG

The testing rig applied a programme of load and temperature to the sheet specimens. Load was applied by hydraulic jacks and heating was by electric fire bar radiant heaters.

The rig (see Fig.3) was in four sectors, each of which contained an upper horizontal beam from which six specimens and six hydraulic jacks were suspended. Each sector was subdivided into three units each comprising two specimens and two jacks joined by a lower horizontal beam. The beams were made from 150mm × 75mm steel channels bolted together back to back with 25mm packing pieces between so that the hydraulic jacks and specimens could be attached at their longitudinal centrelines. To ensure that the movements of the jacks and specimens were co-planar, the jacks were attached to gimble brackets clamped to the lower beam. Tubular legs supported the upper beam and, through the specimen, the weight of the hydraulic jacks and lower beam. (As the specimen supported the jacks and lower beam, when the specimen was in the nominally 'unloaded' condition during testing, it actually carried a dead weight of 445 newtons, i.e. no more than 2MN/m^2 applied stress on the smaller specimen used.) The different load levels required during one complete flight cycle were controlled by electro-mechanical selector valves, and during fatigue cycling the amplitude of the loads was controlled by Budenberg max-min electrical contact pressure gauges. The complete mechanical loading programme was regulated by a Post Office type uniselector switch, and pressure relief valves were incorporated in the hydraulic system as a protection against overload.

All six specimens in a sector of three sections experienced the same mechanical loads. To check the hydraulic jack loads, a Macklow-Smith hydraulic load cell was interposed between the upper beam and the jack rod, and the hydraulic controls were adjusted so that all loads were within $\pm 1\%$ of nominal. During this calibration stage, readings from the pressure gauges of each hydraulic jack were noted and used as a standard against the daily checks of the loads. As individual tests were completed, specimens were replaced by dummy specimens.

Each specimen was heated independently by radiant heaters consisting of two 1kW electric fire bars positioned 65mm away from each side of the sheet specimen. The fire bars were mounted in an aluminium box which surrounded the specimen; the

reflective aluminium ensured that the majority of the heat was absorbed by the sheet specimen, the faces of which were painted black with a high-temperature matt finish paint to improve absorption. The sections of each specimen where cracks were to grow were left unpainted to facilitate inspection and measurement of fatigue cracks. Temperature control was by an electrical resistance element attached to the specimen close to the central hole - hole A for crack initiation specimens (see Fig.1) - and temperatures were monitored by TIT2 thermocouples. For crack initiation tests, temperatures were monitored at each of the five test sections. To ensure that the measured temperatures were those of the specimen, the temperature sensors were insulated from the radiant heat from the fire bars. Temperature distribution across each specimen was within $\pm 1^{\circ}\text{C}$ of nominal temperature.

At the start of each heating period, the heaters switched on at a pre-determined power setting and when the temperature was within 2.5°C of the required value, an automatic temperature controller cut into maintain temperature within 0.5°C of the required value. For the crack initiation specimen, the temperature which was monitored and controlled was that for hole A - 150°C - the maximum temperature applied to the specimens. Due to variation in ambient temperature, the temperatures at the other holes could not be maintained within the same accuracy; corresponding variations were $125^{\circ}\text{C} \pm 2^{\circ}\text{C}$, $100^{\circ}\text{C} \pm 3^{\circ}\text{C}$, $70^{\circ}\text{C} \pm 5^{\circ}\text{C}$ and $54^{\circ}\text{C} \pm 5^{\circ}\text{C}$. At the end of the heating period, the power was switched off and the specimen cooled by free convection to ambient temperature before fatigue gust loading was applied.

Table 1

CHEMICAL COMPOSITION AND TENSILE PROPERTIES OF CM001-1FChemical composition

Core material

Element	% by weight	
	Min	Max
Cu	1.8	2.7
Mg	1.2	1.8
Si	0.15	0.25
Fe	0.9	1.4
Mn	-	0.2
Ni	0.8	1.4
Zn	-	0.1
Pb	-	0.05
Sn	-	0.05
Ti	-	0.2
Aluminium	-	Remainder

Cladding

Element	% by weight	
	Min	Max
Zinc	0.8	1.2
Aluminium	-	Remainder

Tensile properties - mean values from 22 tests

0.2% proof stress	=	376MN/m ²
UTS	=	410 MN/m ²
Elongation (on 50mm gauge length)	=	7%

Table 2

CRACK INITIATION TESTS UNDER INTERMITTENT HEATING CONDITIONS

Specimen number	Number of flight cycles to 2mm crack length (ratio to the log mean value for 54°C)				
	Maximum temperature of heating cycle °C				
	150	125	100	70	54
43	13549 (0.89)	16705 ^{UB} (1.10)	13816 (0.91)	16705 ^{UB} (1.10)	15340 (1.01)
44	12667 (0.84)	9861 (0.65)	16705 ^{UB} (1.10)	13432 (0.89)	14737 (0.97)
45	11137 (0.74)	14590 (0.96)	8593 (0.57)	16705 ^{UB} (1.10)	14328 (0.95)
46	10625 (0.70)	8700 (0.57)	11718 (0.77)	14203 (0.94)	15760 (1.04)
47	12131 (0.80)	13358 (0.88)	16705 ^{UB} (1.10)	10219 (0.67)	15588 (1.03)
log mean	11976 (0.79)	12717* (0.84)	14023* (0.93)	14886* (0.98)	15141 (1.00)

Table 3

CRACK INITIATION TESTS UNDER INTERMITTENT CREEP CONDITIONS

Specimen number	Number of flight cycles to 2mm crack length (ratio to the log mean value for 54°C)				
	Maximum temperature of heating cycle °C				
	150	125	100	70	54
37	19214 (1.10)	16112 (0.93)	55572 ^{UB} (3.19)	15941 (0.92)	9441 (0.54)
38	15786 (0.91)	20740 (1.19)	25767 (1.48)	18203 (1.05)	13243 (0.76)
39	23848 (1.37)	22991 (1.32)	23458 (1.35)	32418 ^{UB} (1.86)	21484 (1.23)
40	14786 (0.85)	16973 (0.98)	23651 (1.36)	13542 (0.78)	38695 (2.22)
41	17648 (1.01)	32087 (1.84)	50750 ^{UB} (2.92)	19349 (1.11)	15371 (0.88)
log mean	17996 (1.03)	21102 (1.21)	34592* (1.99)	17860* (1.03)	17406 (1.00)

UB = uncracked specimen result
 * mean endurances calculated by J.S. Lariviere's method¹⁰

REFERENCES

- | <u>No.</u> | <u>Author</u> | <u>Title, etc.</u> |
|------------|---------------------------------|--|
| 1 | M.S. Binning | Direct stress fatigue tests on DTD 5070A, BSL73 and 2024-T81 sheets.
RAE Technical Report 70221 (1970) |
| 2 | M.F. Day | Residual tensile properties of DTD 5070A, BSL73 and Alclad 2024-T81 sheets after long time creep tests in the temperature range 100 to 150°C.
Unpublished MOD(PE) material |
| 3 | F.E. Kiddle | The influence of a single application of heat on crack propagation in DTD 5070A (RR58) aluminium alloy sheet.
ARC Current Paper No.1272 (1974) |
| 4 | J.R. Heath-Smith
F.E. Kiddle | Effect of interrupting fatigue by periods of heat for aluminium alloy structural elements.
In "Fatigue at Elevated Temperatures"
A.E. Carden, A.J. McEvily and C.H. Wells, Eds.,
ASTM, STP520, pp 500-511 (1973) |
| 5 | J.R. Heath-Smith
F.E. Kiddle | Effects of heat on fatigue in aircraft structure.
RAE Technical Report 75131 (1975) |
| 6 | F.E. Kiddle | Influence of prior heat and creep on fatigue in structural elements of DTD 5014 (RR58) Al-Cu alloy.
RAE Technical Report 76094 (1976) |
| 7 | F.E. Kiddle
R.J. Kite | The effect of interspersed heating on the fatigue endurance of aluminium alloy riveted lap joints in CM001 material.
RAE Technical Report 74052 (1974) |
| 8 | F.E. Kiddle
A.K. Redfern | The development of acceleration techniques for fatigue tests involving periodic heating.
SEE Fatigue Group International Conference
"Fatigue Testing and Design" City University, London
5-9 April 1976
[Also available as "Fatigue testing with periodic heating - an investigation of some methods of acceleration", F.E. Kiddle and A.K. Redfern.
RAE Technical Report 76082 (1976)] |

REFERENCES (concluded)

- | <u>No.</u> | <u>Author</u> | <u>Title, etc.</u> |
|------------|---|---|
| 9 | A.W. Cardrick
R.W. Gardiner | A replica method for recording the surface growth of fatigue microcracks.
RAE Technical Report 72210 (1973) |
| 10 | J.S. Lariviere | Calculation of the operating life of helicopter blades.
Note STA/VT No.165 |
| 11 | L.N. McCartney
Mrs. P. Cooper | Computerised processing of fatigue crack propagation data.
NPL Report Mat App. 23 (1972) |
| 12 | R.D.J. Maxwell
W.T. Kirkby
J.R. Heath-Smith | Influence of heat on crack propagation and residual strength and its relation to the supersonic aircraft fatigue problem.
I.Mech.E. International Conference
"Creep and Fatigue in Elevated Temperature Applications".
Sheffield, 1-5 April 1974 |
| 13 | F.E. Kiddle | The effect of load dwells during fatigue crack propagation.
ARC Current Paper No.1318 (1975) |
| 14 | F.E. Kiddle | Test schedule for heat-fatigue interaction experiments in thin sheet specimens.
Unpublished MOD(PE) material |

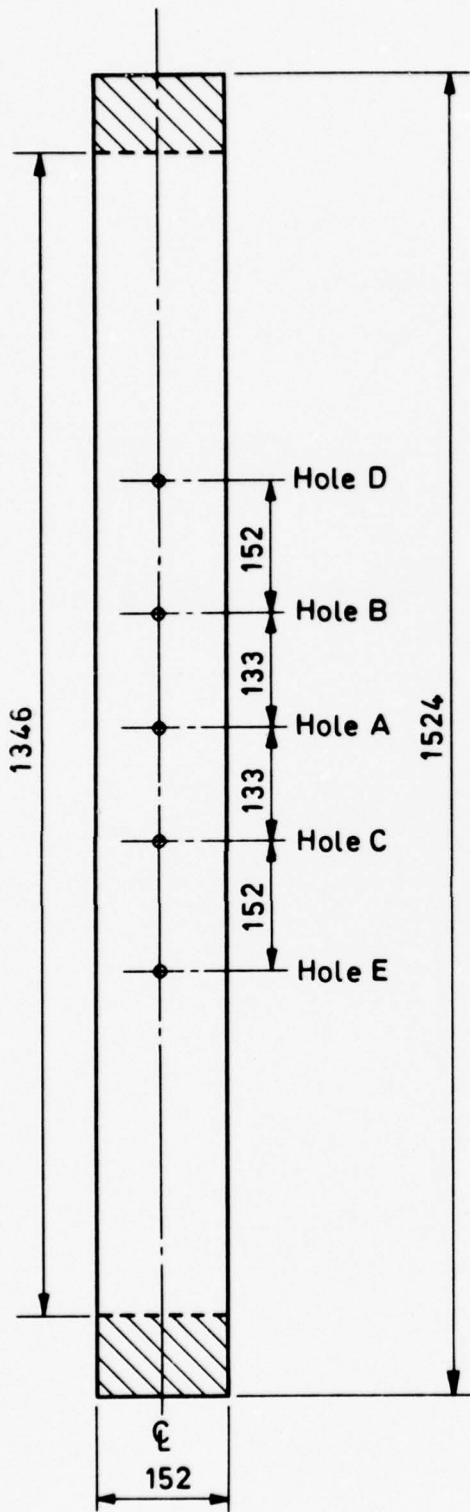

Sheet thickness = 1.6mm
 Holes A-E, 9.5mm dia drilled
 (Theoretical stress concentration factor $K_t = 2.8$)
 Hatched areas covered by end plates
 All dimensions in mm

Fig.1 Crack initiation test specimen

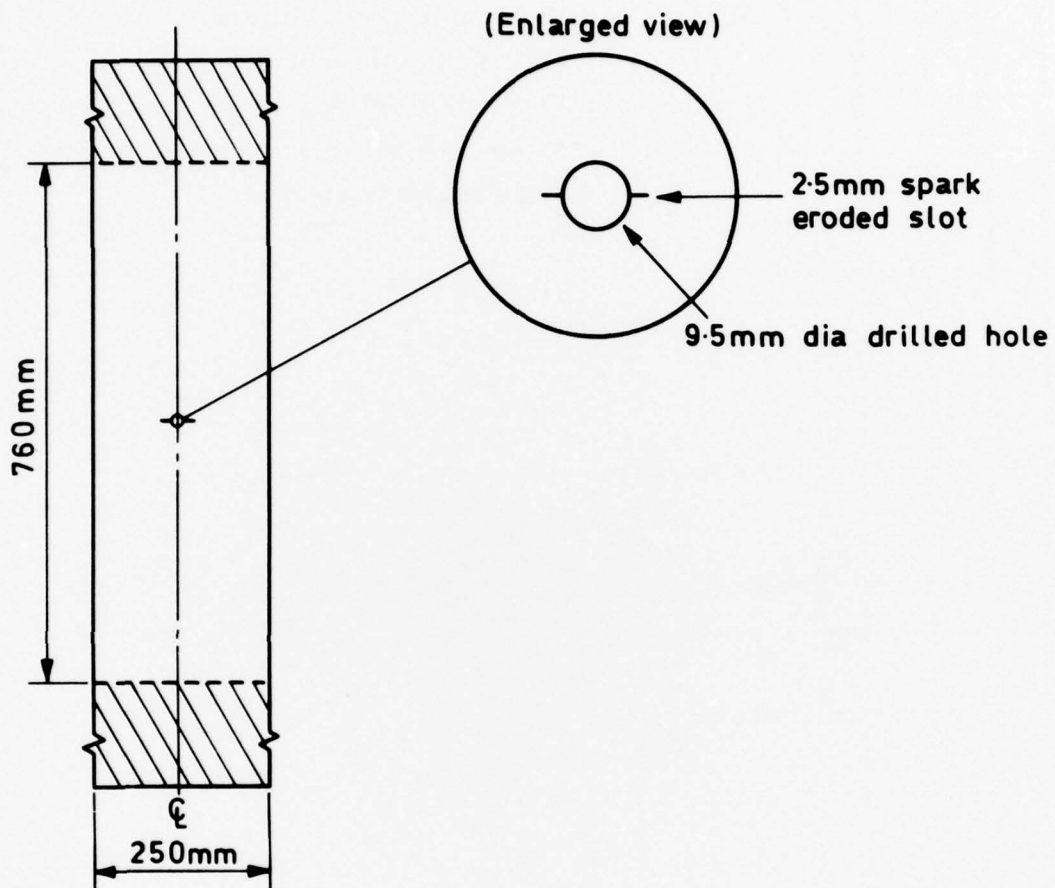

Sheet thickness = 1.6mm
 Hatched areas covered by end plates

Fig. 2 Crack propagation test specimen

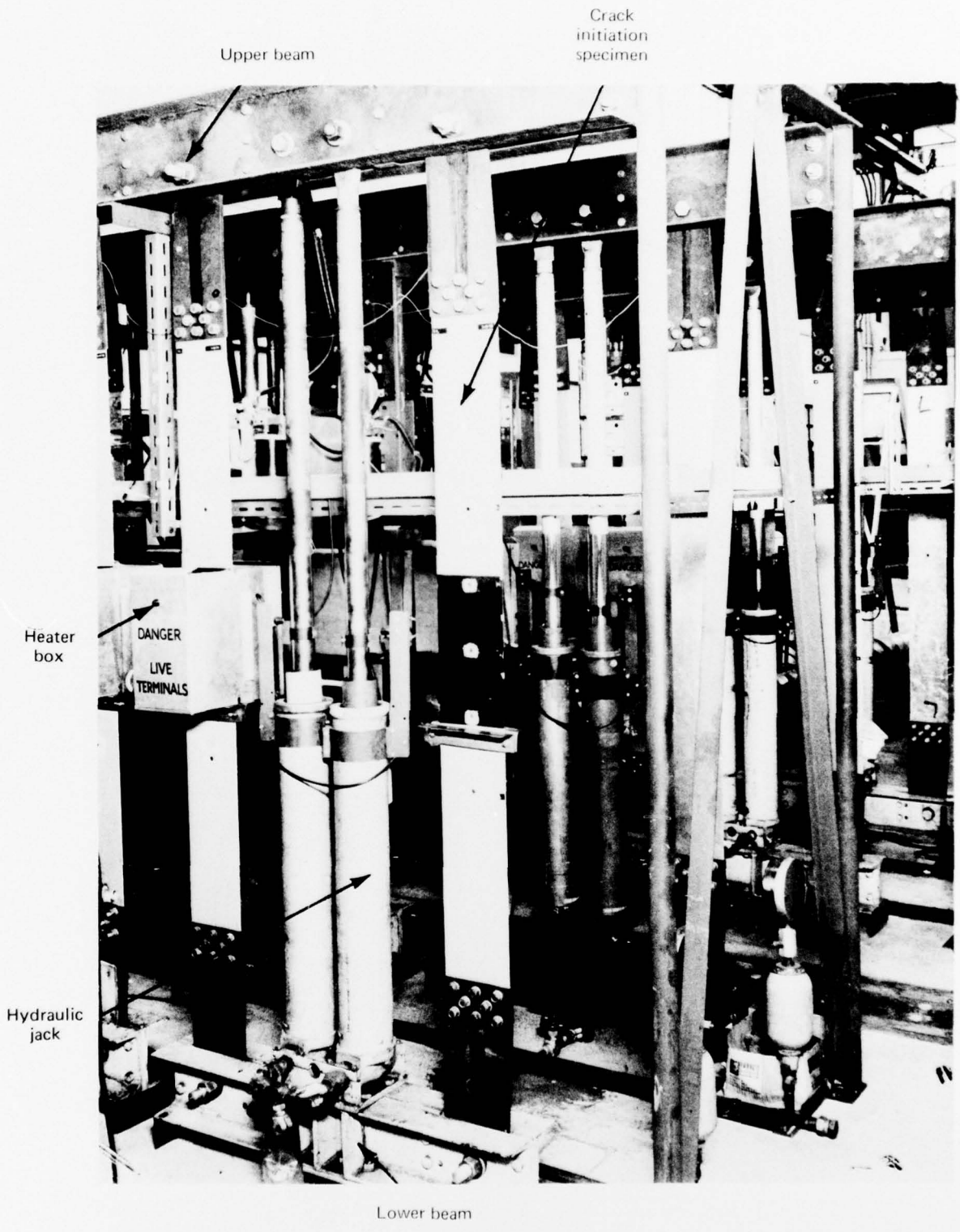

Fig.3 General arrangement of specimens and rig

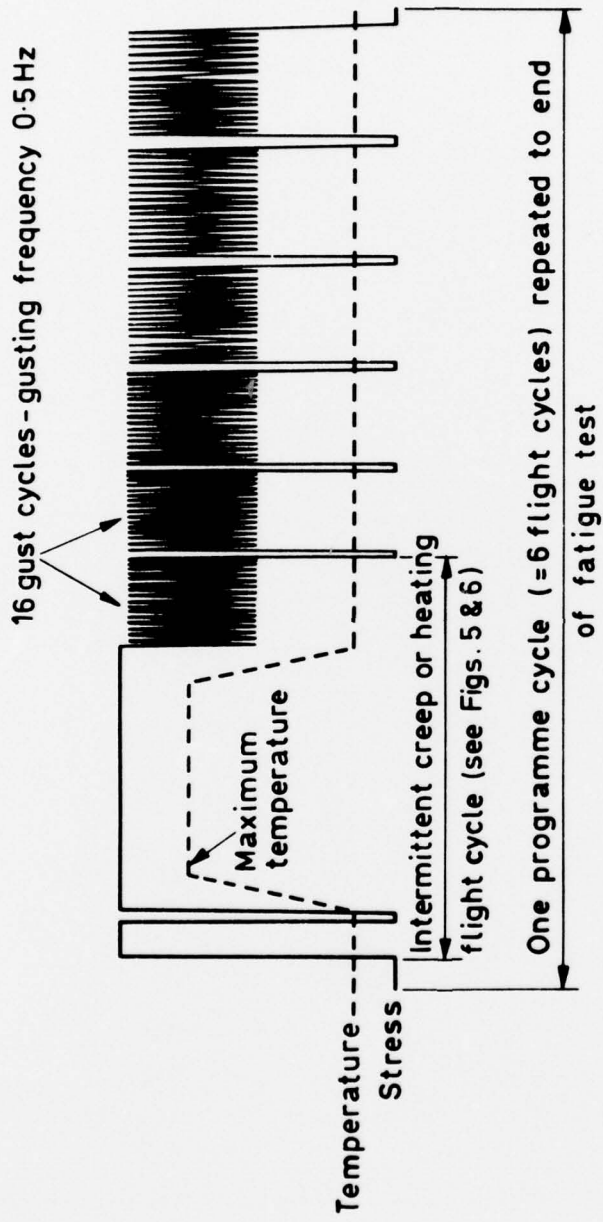
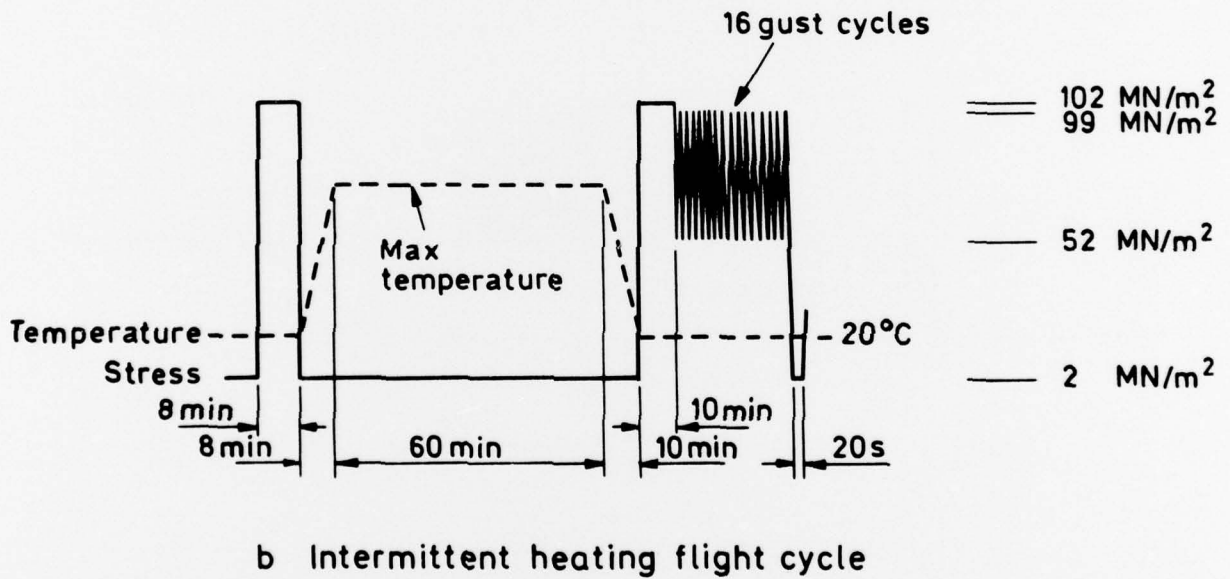
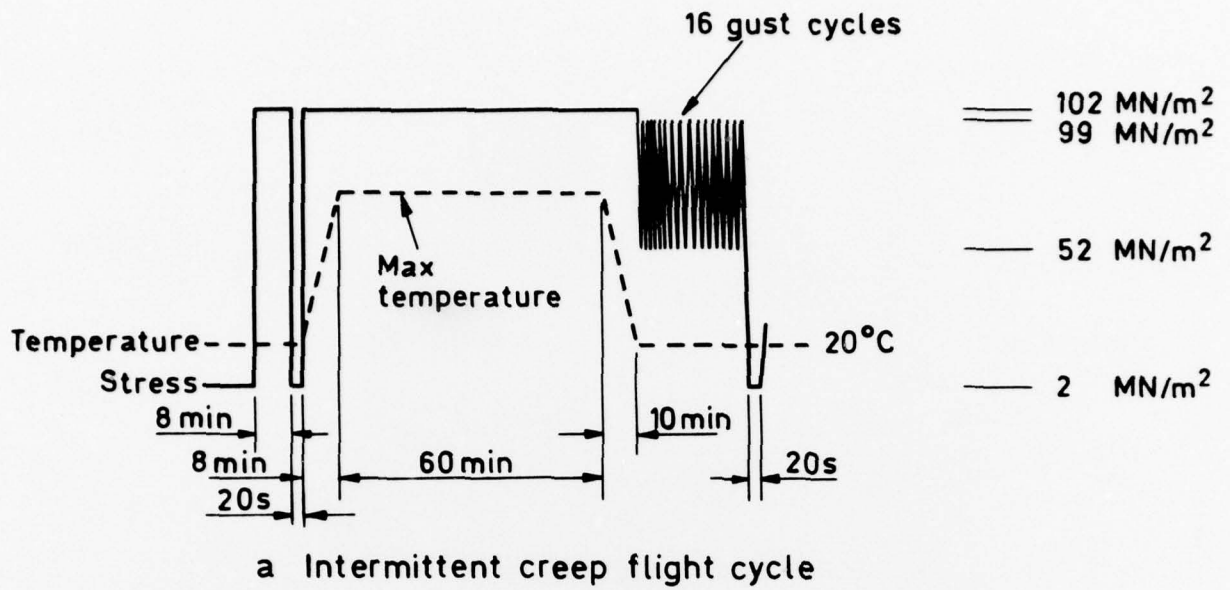
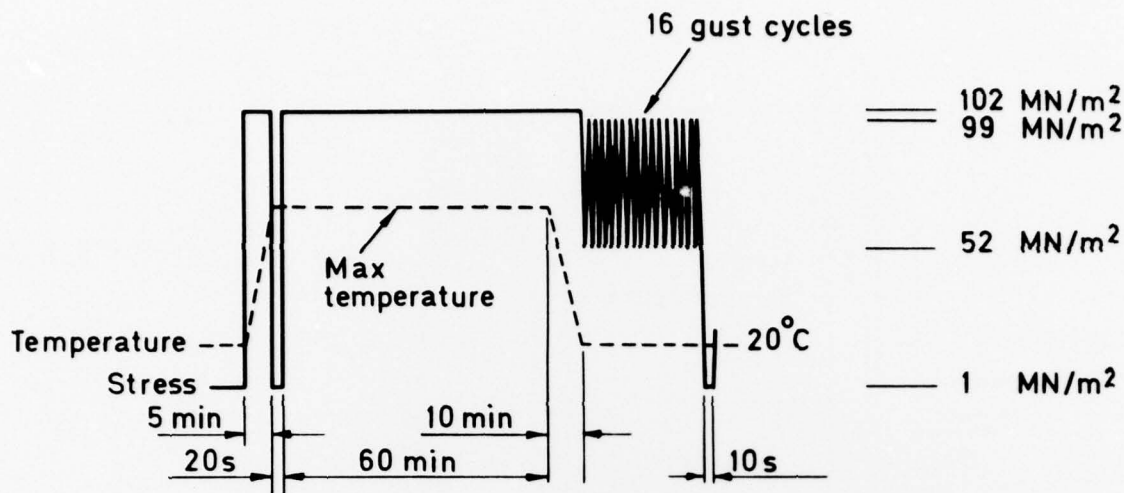

Fig. 4 Generalised loading sequence



All stresses are based on net cross section
 Max temperatures studied 150°C, 125°C, 100°C, 70°C and 54°C
 Gusting frequency 0.5Hz

Fig. 5a&b Load-temperature sequences used for crack initiation tests



a Intermittent creep flight cycle

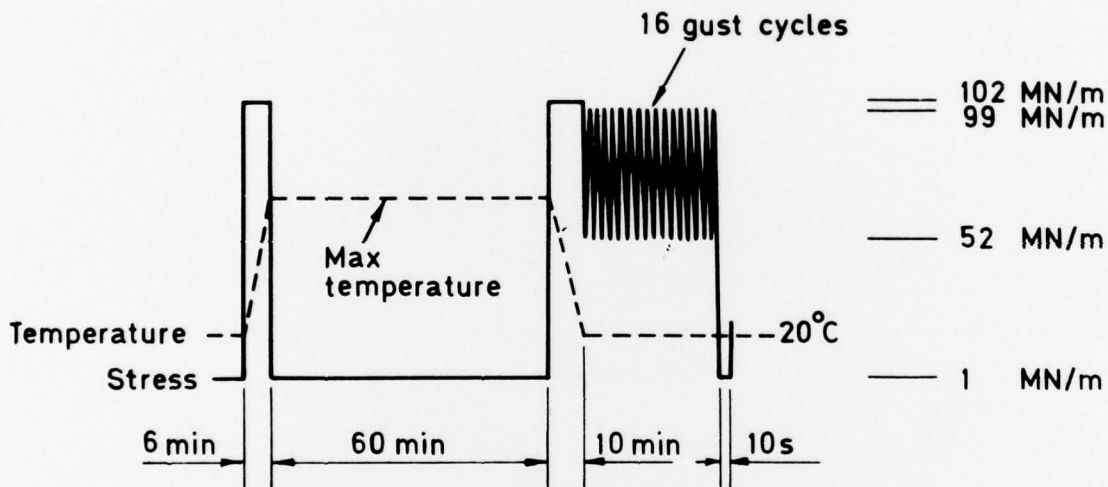

b Intermittent heating flight cycle

All stresses are based on net cross section
 Max temperatures studied 130°C, 100°C and 20°C
 Gusting frequency 0.5 Hz

Fig. 6a&b Load-temperature sequences used for crack propagation tests

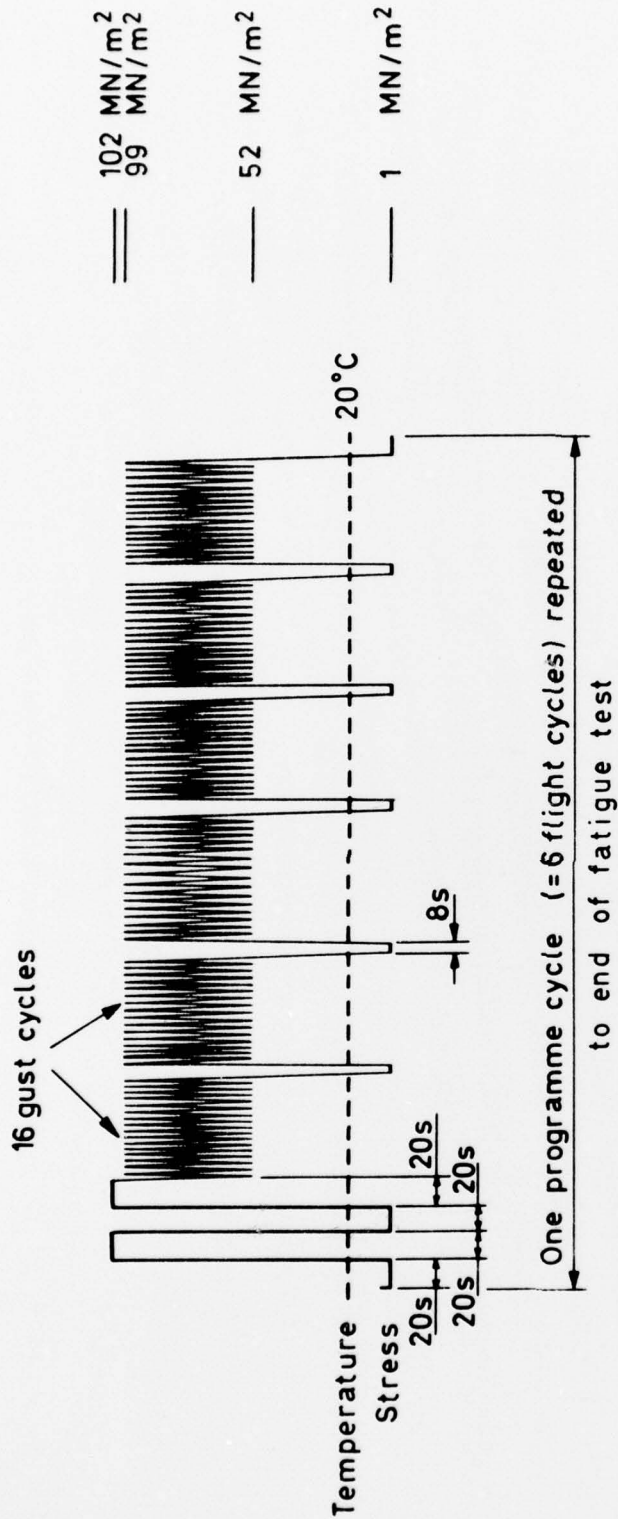

All stresses are based on net cross section

Gusting frequency 0.5 Hz

- Prior 'heating' history:
- a 175.5 MN/m² stress applied for 3000 h, specimen temperature 20°C
 - b 175.5 MN/m² stress applied for 3000 h, specimen temperature 130°C (permanent creep strain = 0.068%)
 - c 0 MN/m² stress applied for 3000 h, specimen temperature 130°C

Fig. 7 Load sequence used for crack propagation tests on specimens with a prior 'heating' history

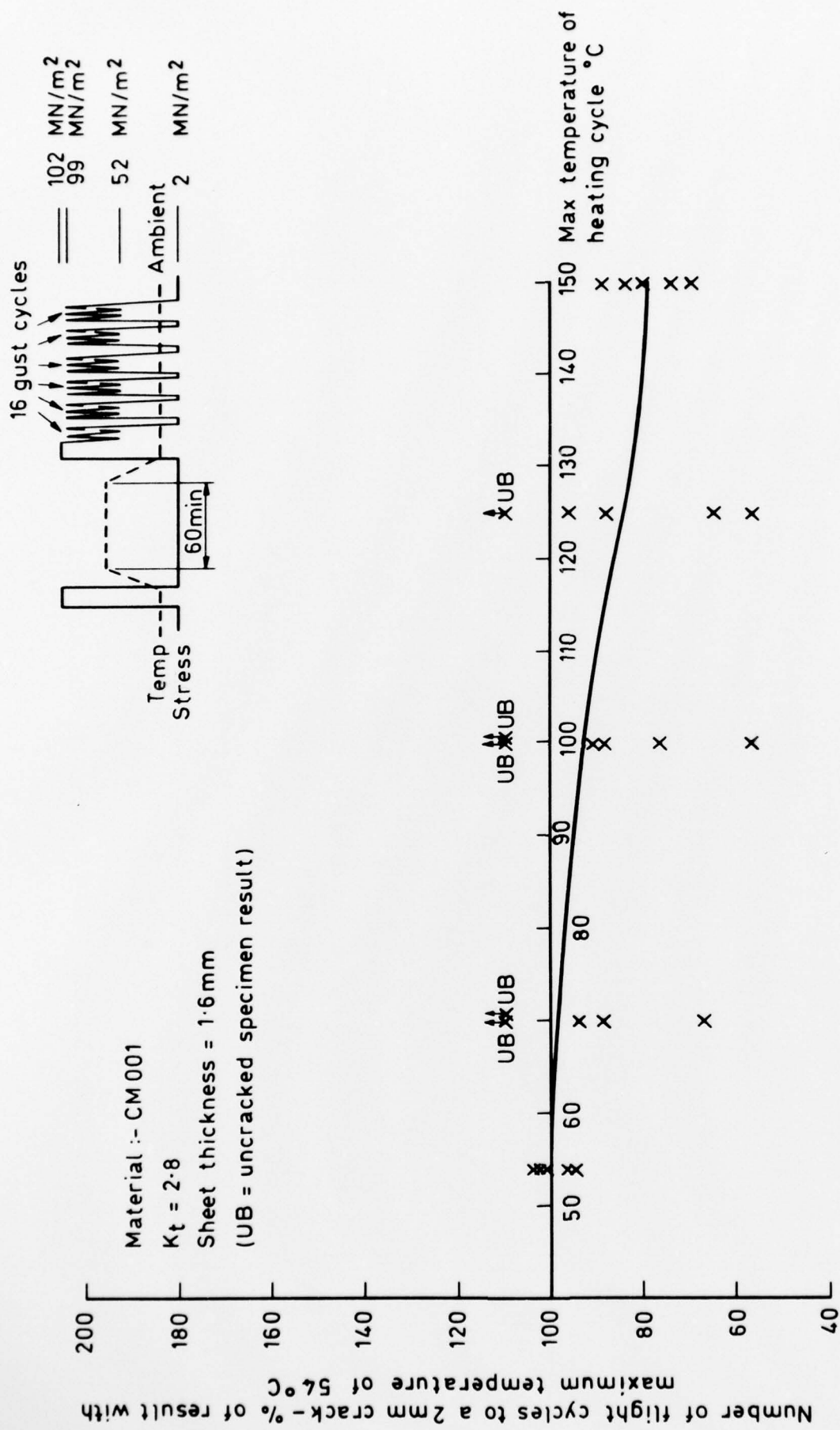

Fig. 8 The effect of intermittent heating on crack initiation and early crack growth

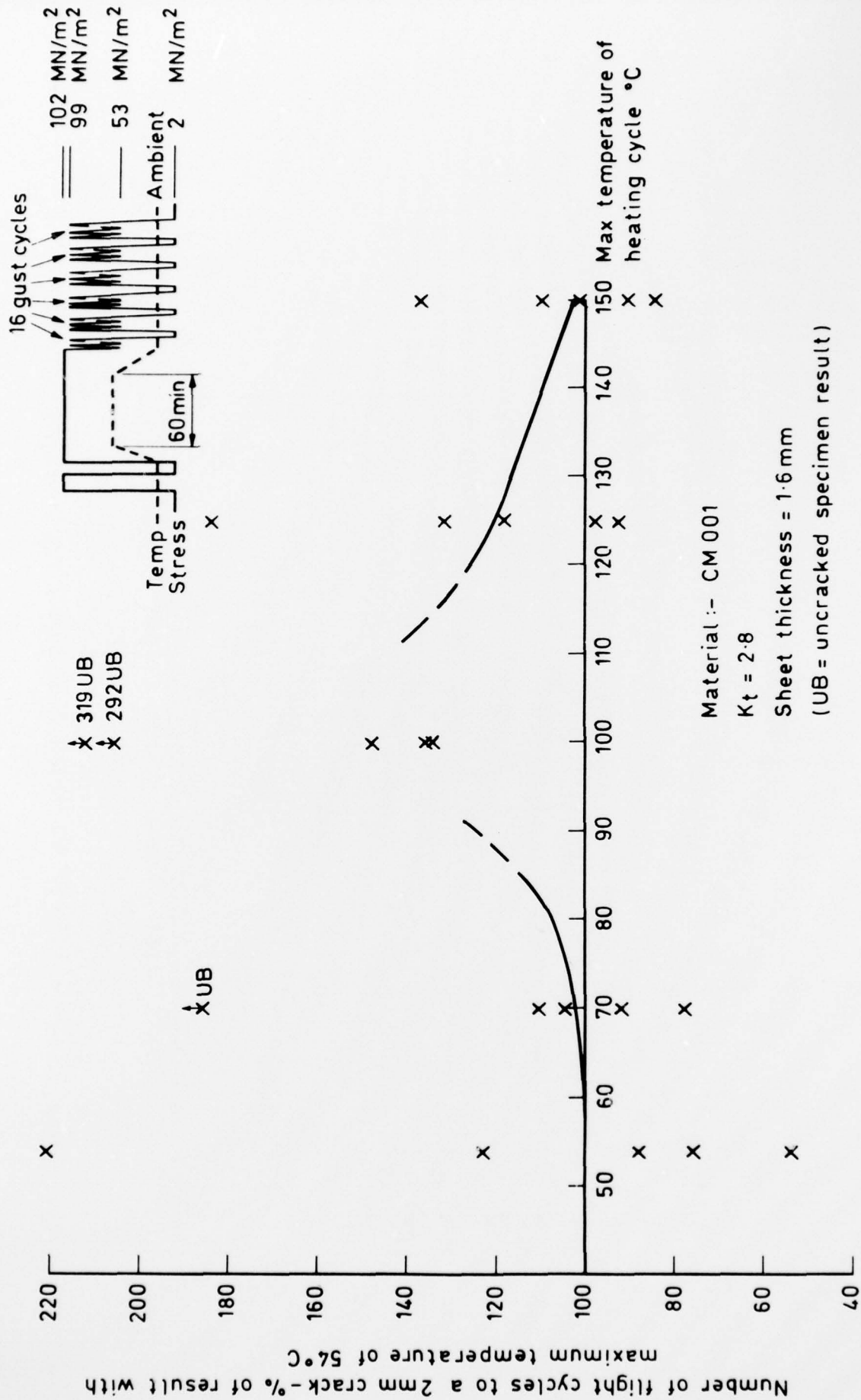

Fig. 9 The effect of intermittent creep on crack initiation and early crack growth

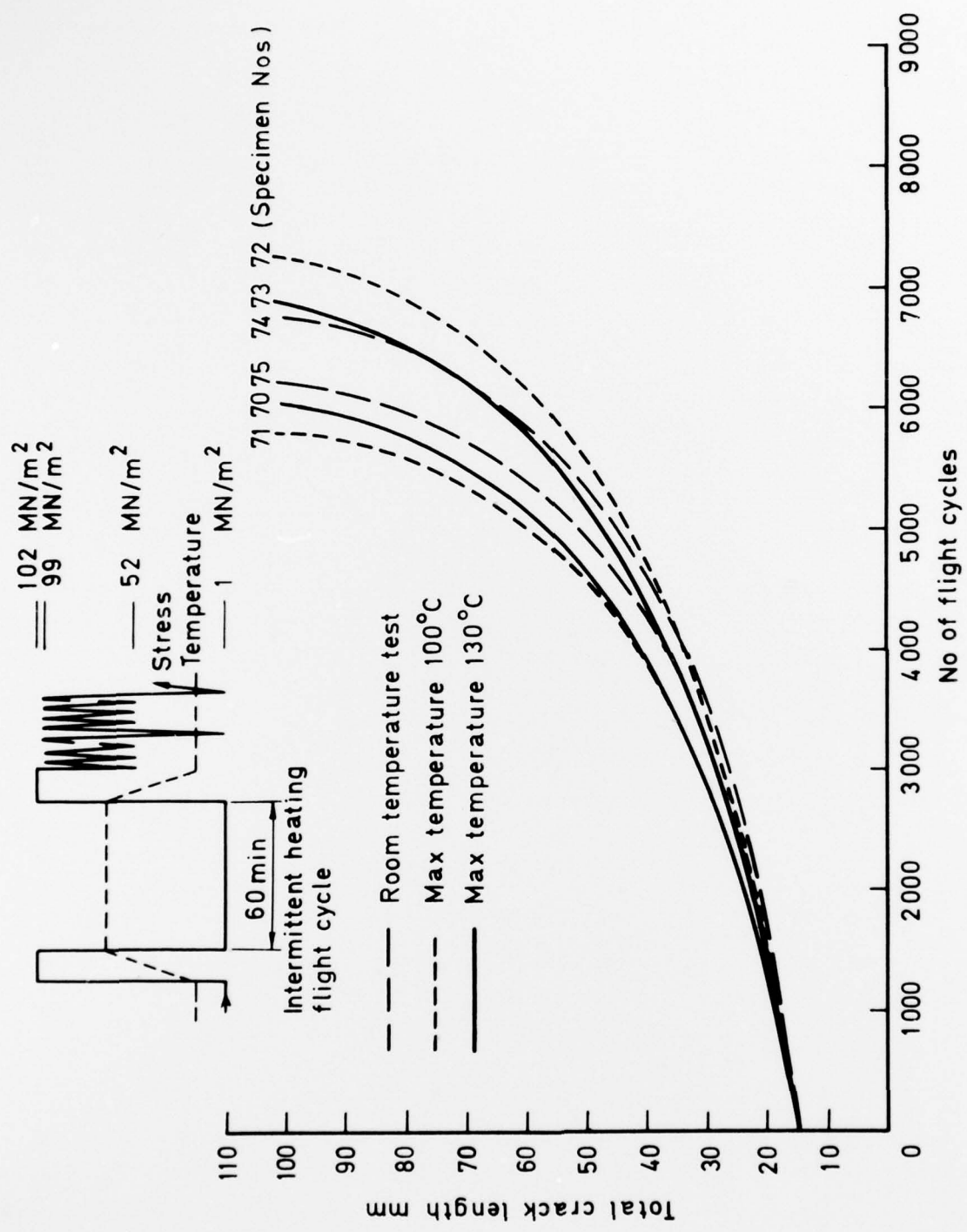

Fig.10 Effect of intermittent heating on crack growth

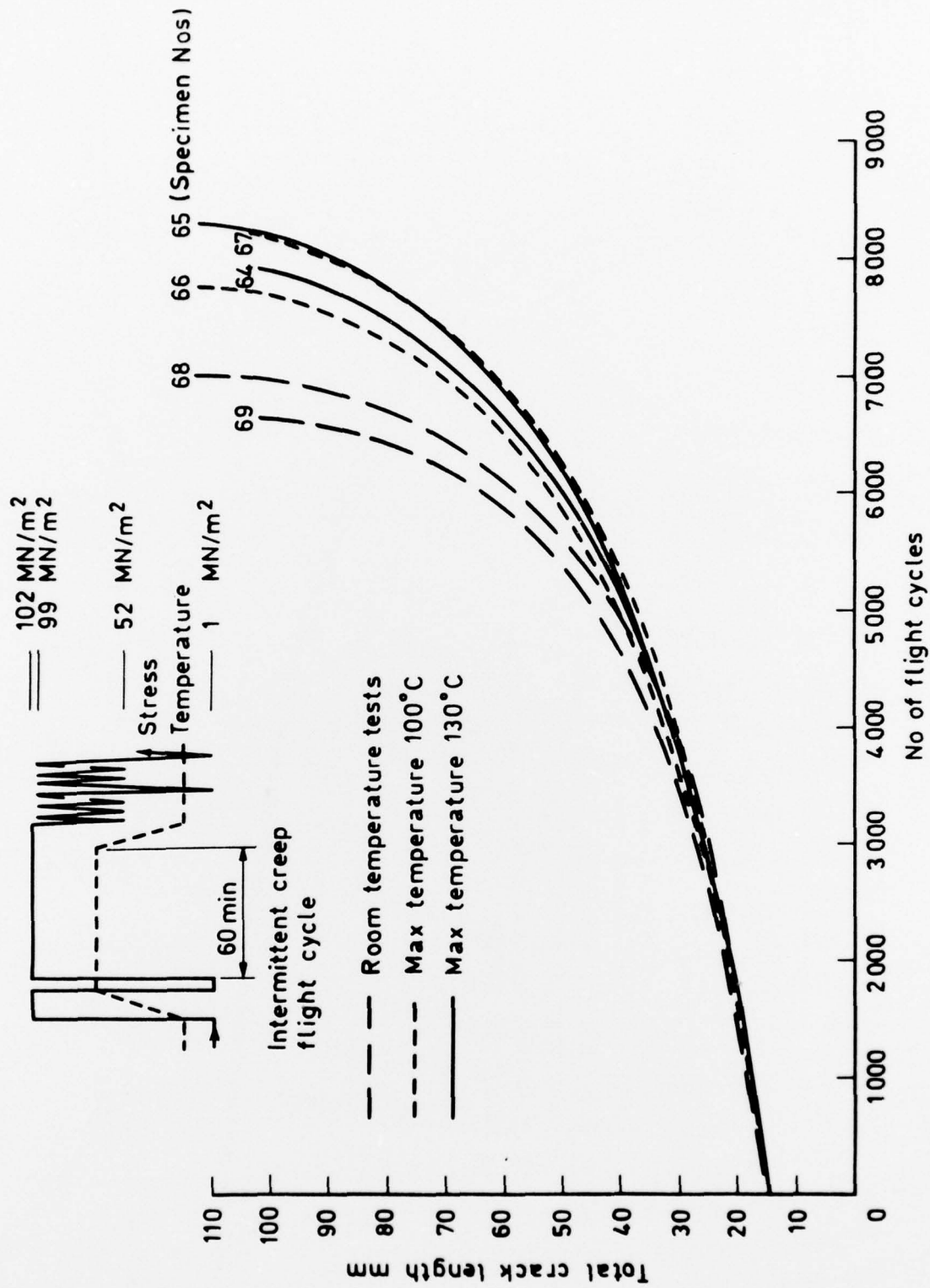

Fig.11 Effect of intermittent creep on crack growth

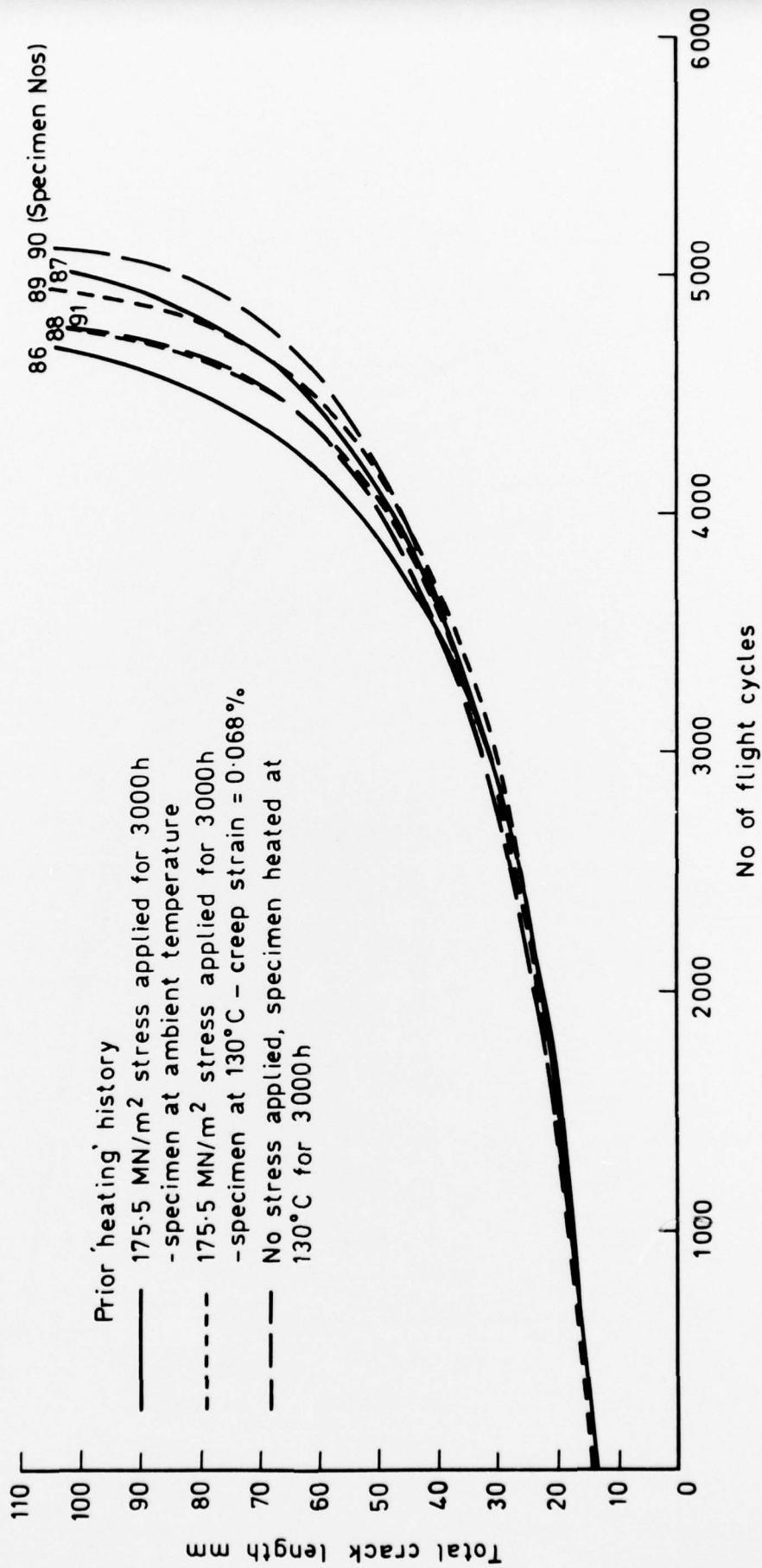
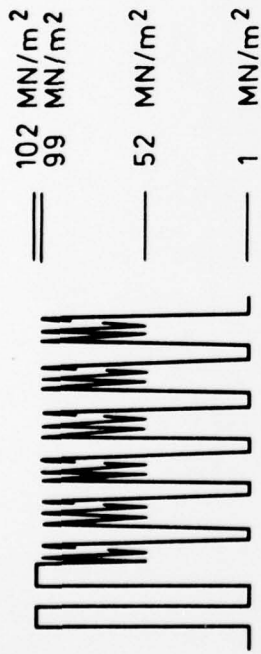

Fig. 12 The effect of prior heating on crack growth at room temperature

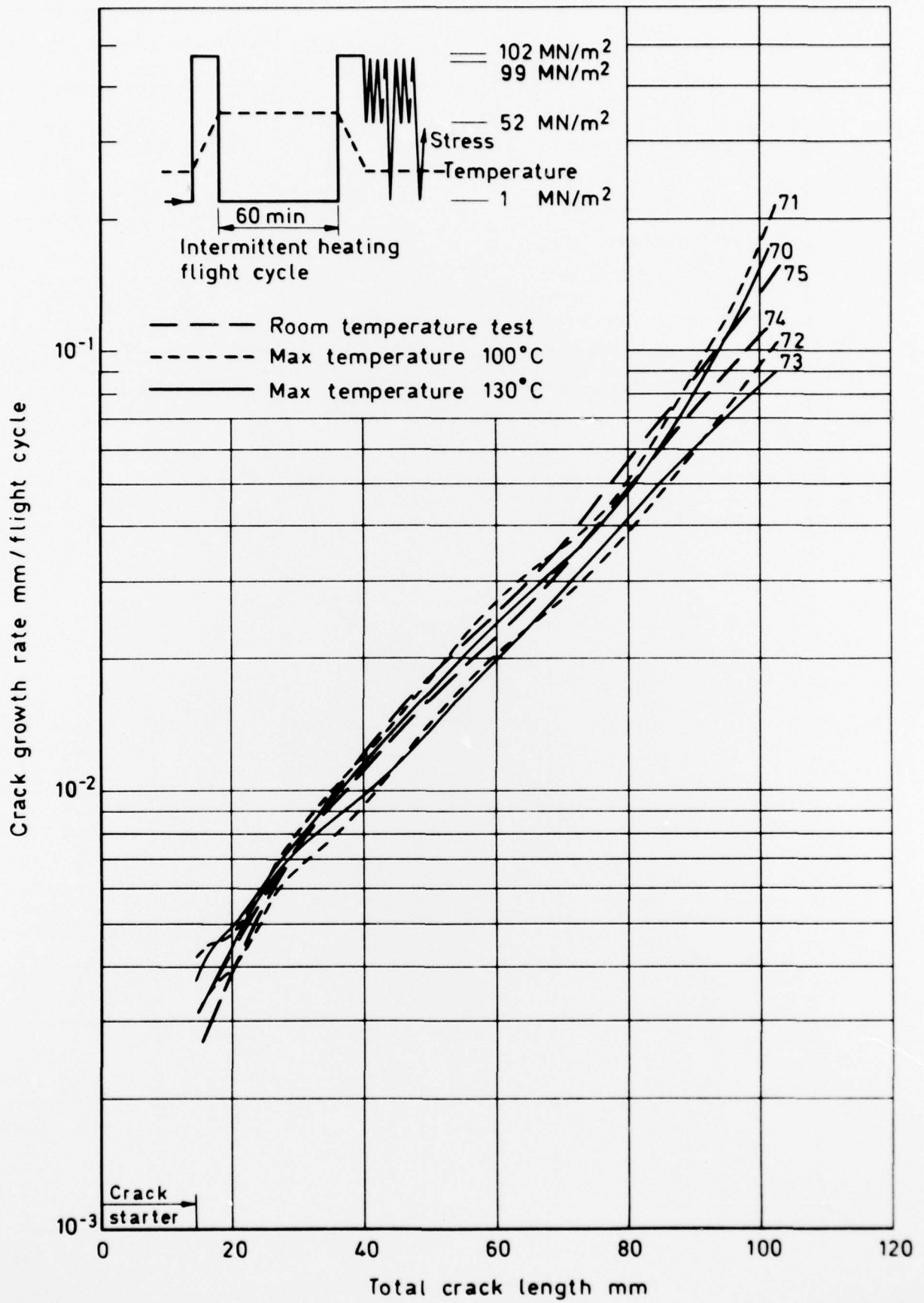

Fig. 13 Effect of intermittent heating on crack growth rate

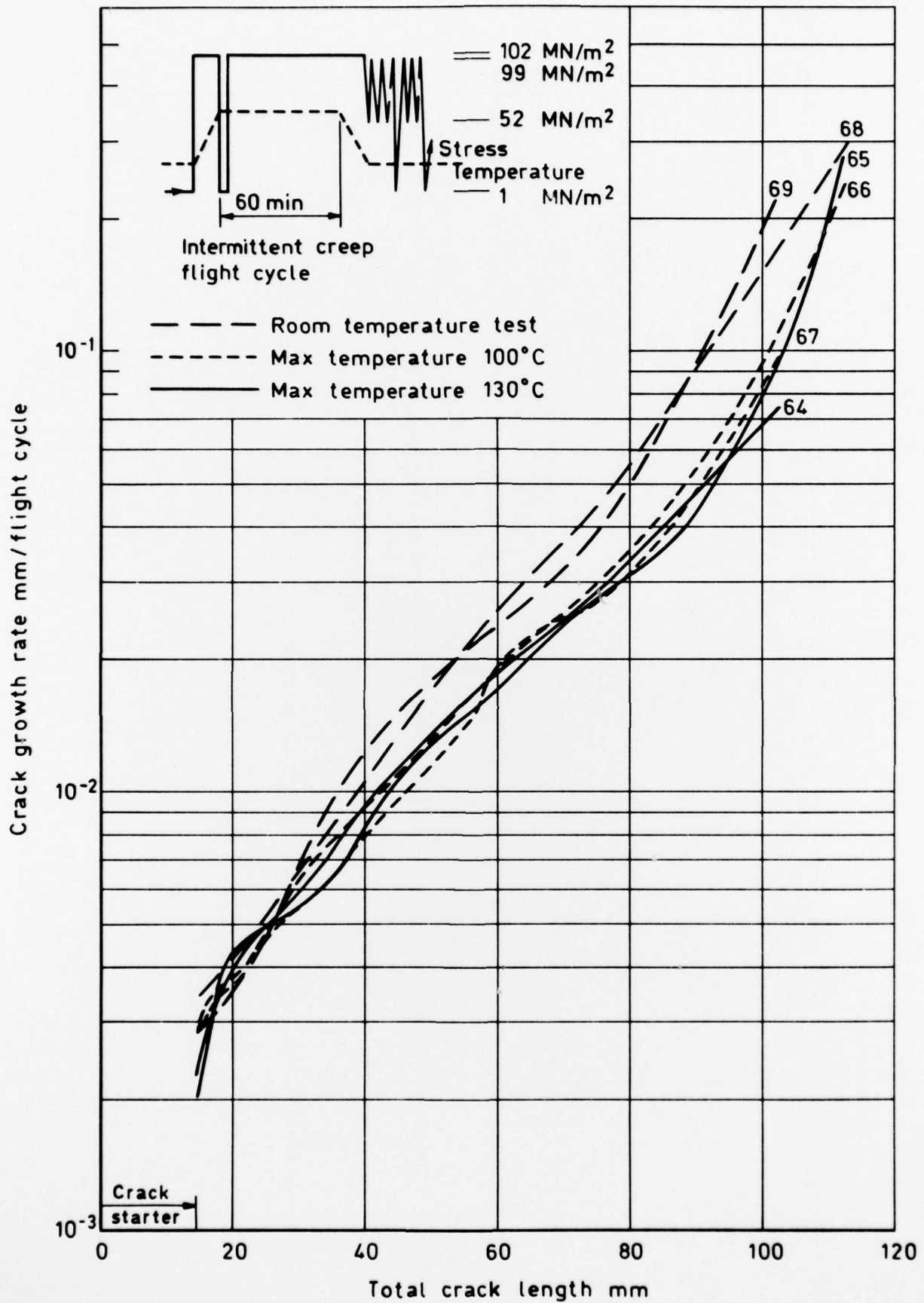

Fig. 14 Effect of intermittent creep on crack growth rate

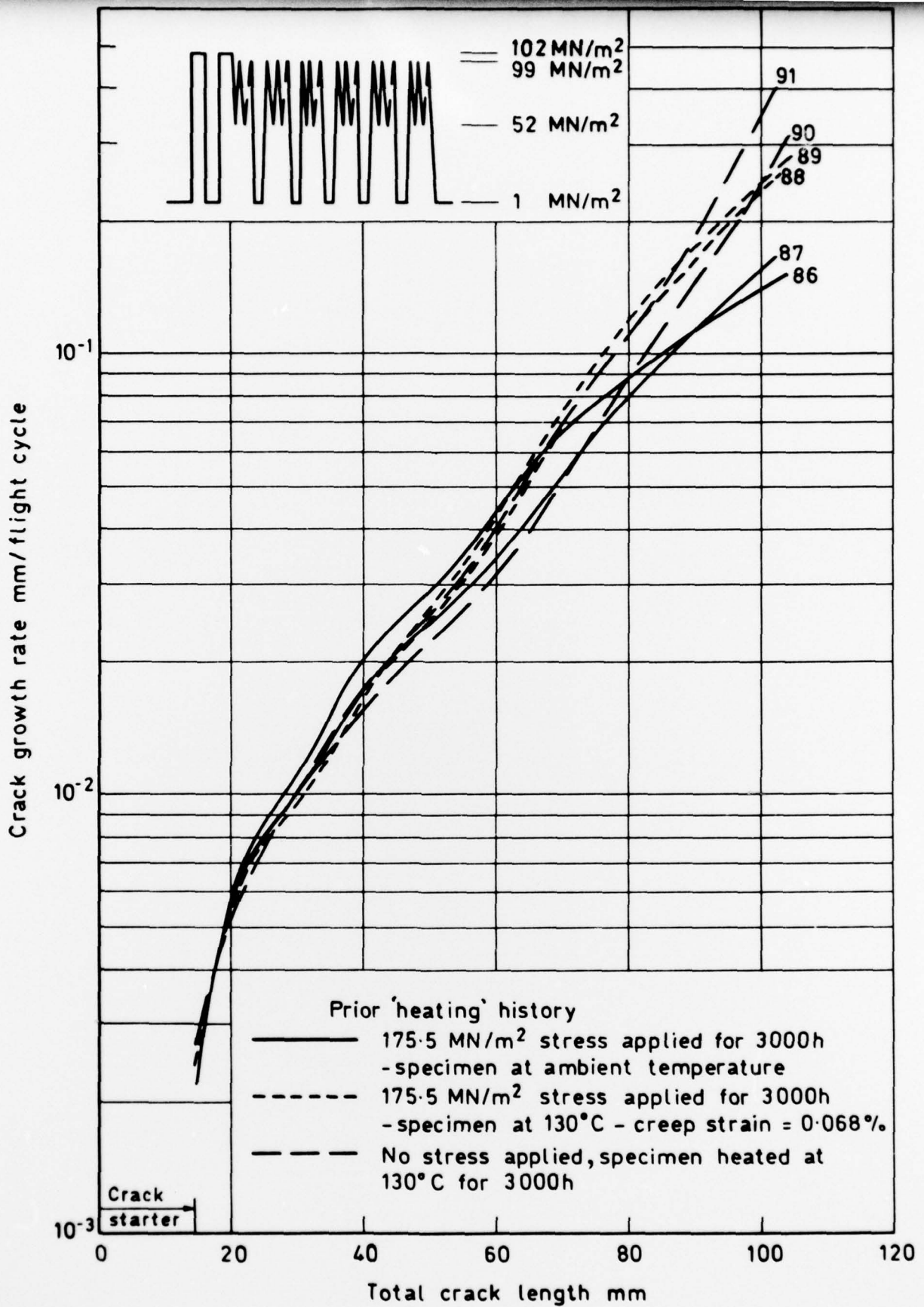

Fig. 15 Effect of prior heating on crack growth rate

ARC CP No.1366
July 1976

539,388.1 :
539,219.2 :
539,377 :
539,4,013.3 :
669,715-415:
620,178,38

Kiddle, F. E.

EFFECT OF INTERSPERSED PERIODS OF HEATING ON FATIGUE CRACK
INITIATION AND PROPAGATION IN CM001 (RR58) CLAD SHEET

Fatigue tests have been conducted to study the effect of interspersed periods of heating on the initiation and early growth of cracks from holes in clad sheet and also on later stages of crack propagation. The tests were under flight simulation loading and the material was CM001 (RR58) clad aluminum alloy sheet.

Interspersed heating reduced the lives to initiate and grow cracks to 2mm and this is attributed to the softening of strain hardened material at the crack tip, but no effect was observed for longer crack lengths. When load was applied during the periods of heating creep redistribution of local stress retarded the growth of short and long cracks. Further work is underway to investigate fatigue-heat interactions under different load-temperature sequences, other forms of material, and over a wider range of crack lengths.

ARC CP No.1366
July 1976

539,388.1 :
539,219.2 :
539,377 :
539,4,013.3 :
669,715-415:
620,178,38

Kiddle, F. E.

EFFECT OF INTERSPERSED PERIODS OF HEATING ON FATIGUE CRACK
INITIATION AND PROPAGATION IN CM001 (RR58) CLAD SHEET

Fatigue tests have been conducted to study the effect of interspersed periods of heating on the initiation and early growth of cracks from holes in clad sheet and also on later stages of crack propagation. The tests were under flight simulation loading and the material was CM001 (RR58) clad aluminum alloy sheet.

Interspersed heating reduced the lives to initiate and grow cracks to 2mm and this is attributed to the softening of strain hardened material at the crack tip, but no effect was observed for longer crack lengths. When load was applied during the periods of heating creep redistribution of local stress retarded the growth of short and long cracks. Further work is underway to investigate fatigue-heat interactions under different load-temperature sequences, other forms of material, and over a wider range of crack lengths.

DETACHABLE ABSTRACT CARDS

ARC CP No.1366
July 1976

539,388.1 :
539,219.2 :
539,377 :
539,4,013.3 :
669,715-415:
620,178,38

Kiddle, F. E.

EFFECT OF INTERSPERSED PERIODS OF HEATING ON FATIGUE CRACK
INITIATION AND PROPAGATION IN CM001 (RR58) CLAD SHEET

Fatigue tests have been conducted to study the effect of interspersed periods of heating on the initiation and early growth of cracks from holes in clad sheet and also on later stages of crack propagation. The tests were under flight simulation loading and the material was CM001 (RR58) clad aluminum alloy sheet.

Interspersed heating reduced the lives to initiate and grow cracks to 2mm and this is attributed to the softening of strain hardened material at the crack tip, but no effect was observed for longer crack lengths. When load was applied during the periods of heating creep redistribution of local stress retarded the growth of short and long cracks. Further work is underway to investigate fatigue-heat interactions under different load-temperature sequences, other forms of material, and over a wider range of crack lengths.

ARC CP No.1366
July 1976

539,388.1 :
539,219.2 :
539,377 :
539,4,013.3 :
669,715-415:
620,178,38

Kiddle, F. E.

EFFECT OF INTERSPERSED PERIODS OF HEATING ON FATIGUE CRACK
INITIATION AND PROPAGATION IN CM001 (RR58) CLAD SHEET

Fatigue tests have been conducted to study the effect of interspersed periods of heating on the initiation and early growth of cracks from holes in clad sheet and also on later stages of crack propagation. The tests were under flight simulation loading and the material was CM001 (RR58) clad aluminum alloy sheet.

Interspersed heating reduced the lives to initiate and grow cracks to 2mm and this is attributed to the softening of strain hardened material at the crack tip, but no effect was observed for longer crack lengths. When load was applied during the periods of heating creep redistribution of local stress retarded the growth of short and long cracks. Further work is underway to investigate fatigue-heat interactions under different load-temperature sequences, other forms of material, and over a wider range of crack lengths.

DETACHABLE ABSTRACT CARDS

Cur here

Cur here