

AD-A041 139

OHIO UNIV ATHENS DEPT OF ELECTRICAL ENGINEERING F/6 17/7
THE PERFORMANCE OF THE NULL-REFERENCE GLIDE-SLOPE SYSTEM IN THE--ETC(U)
JAN 77 L H MITCHELL, R H MCFARLAND DOT-FA76WA-3764
EER-29-1 FAA-RD-77-24 NL

UNCLASSIFIED

| OF |
AD
A041139

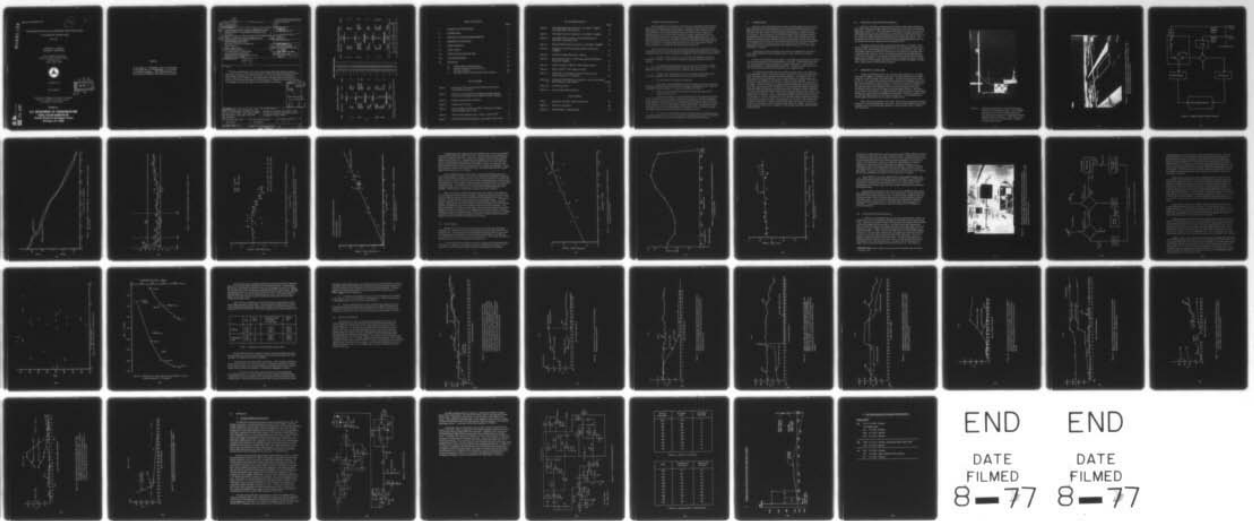

Report No. FAA-RD-77-24

12

ADA 041 139

THE PERFORMANCE OF THE NULL-REFERENCE GLIDE-SLOPE SYSTEM
IN THE PRESENCE OF DEEP SNOW
1975-1976

LAWRENCE H. MITCHELL
RICHARD H. MCFARLAND

Avionics Engineering Center
Department of Electrical Engineering
Ohio University
Athens, Ohio 45701



JANUARY 1977

FINAL REPORT

DDC
RECEIVED
JUN 28 1977
RECEIVED

Handwritten initials and the letter 'A' below the stamp.

Document is available to the public through the
National Technical Information Service,
Springfield, Virginia 22161.

Prepared for

U.S. DEPARTMENT OF TRANSPORTATION
FEDERAL AVIATION ADMINISTRATION
Systems Research & Development Service
Washington, D.C. 20590

AD No. _____
DDC FILE COPY

NOTICE

This document is disseminated under the sponsorship of the Department of Transportation in the interest of information exchange. The United States Government assumes no liability for the contents or use thereof.

Technical Report Documentation Page

1. Report No. 18 FAA-RD-77-24 19	2. Government Accession No.	3. Recipient's Catalog No. 11
4. Title and Subtitle 6 THE PERFORMANCE OF THE NULL-REFERENCE GLIDE-SLOPE SYSTEM IN THE PRESENCE OF DEEP SNOW 1975-1976,	5. Report Date January 1977	
7. Author(s) 10 Lawrence H. Mitchell / Richard H. McFarland 14	6. Performing Organization Code	
9. Performing Organization Name and Address Avionics Engineering Center Department of Electrical Engineering Ohio University Athens, Ohio 45701	8. Performing Organization Report No. EER-29-1 14	
12. Sponsoring Agency Name and Address U.S. Department of Transportation Federal Aviation Administration Systems Research and Development Service Washington, D.C. 20590	10. Work Unit No. (TRAIS)	
15. Supplementary Notes 12 49p.	11. Contract or Grant No. DOT-FA76WA-3764 <i>new</i> 15	
16. Abstract Results of measurements on far-field, null-reference glide slope response to ground plane snow cover of up to 34 inches are presented. Results show that the path angle increases approximately 0.10 degree for each foot of snow cover, and no significant deterioration occurs in path width or clearance. Results obtained for the deep snows are consistent with theory and with previous measurements with lesser amounts. Special far-field monitoring using a two-frequency capture type monitor was only marginally successfully.	13. Type of Report and Period Covered Final Report. December 1975-May 1976. 9	
17. Key Words image glide slope, snow, ground plane, 180° monitor, capture monitor, far field, snow banks, snow plow, snow blower, pilots' reports, glide path performance, path angle, path width, data correlation	14. Sponsoring Agency Code ARD-741	
19. Security Classif. (of this report) Unclassified	20. Security Classif. (of this page) Unclassified	21. No. of Pages 51
18. Distribution Statement Document is available to the public through the National Technical Information Service, Springfield, Virginia 22161.		22. Price

ACCESSION FOR	
NTIS	White Section <input checked="" type="checkbox"/>
DDC	Buff Section <input type="checkbox"/>
UNANNOUNCED	<input type="checkbox"/>
JUSTIFICATION	
BY	
DISTRIBUTION AVAILABILITY CODES	
Dist.	AVAIL. NO. OF SPECIAL
A	

267460

110

METRIC CONVERSION FACTORS

Approximate Conversions to Metric Measures

Symbol	When You Know	Multiply by	To Find	Symbol
LENGTH				
in	inches	2.5	centimeters	cm
ft	feet	30	centimeters	cm
yd	yards	0.9	meters	m
mi	miles	1.6	kilometers	km
AREA				
in ²	square inches	6.5	square centimeters	cm ²
ft ²	square feet	0.09	square meters	m ²
yd ²	square yards	0.8	square meters	m ²
mi ²	square miles	2.6	square kilometers	km ²
	acres	0.4	hectares	ha
MASS (weight)				
oz	ounces	28	grams	g
lb	pounds	0.45	kilograms	kg
	short tons (2000 lb)	0.9	tonnes	t
VOLUME				
tsp	teaspoons	5	milliliters	ml
Tbsp	tablespoons	15	milliliters	ml
fl oz	fluid ounces	30	milliliters	ml
c	cups	0.24	liters	l
pt	pints	0.47	liters	l
qt	quarts	0.95	liters	l
gal	gallons	3.8	liters	l
ft ³	cubic feet	0.03	cubic meters	m ³
yd ³	cubic yards	0.76	cubic meters	m ³
TEMPERATURE (exact)				
°F	Fahrenheit temperature	5/9 (after subtracting 32)	Celsius temperature	°C

Symbol	When You Know	Multiply by	To Find	Symbol
LENGTH				
mm	millimeters	0.04	inches	in
cm	centimeters	0.4	inches	in
m	meters	3.3	feet	ft
m	meters	1.1	yards	yd
km	kilometers	0.6	miles	mi
AREA				
cm ²	square centimeters	0.16	square inches	in ²
m ²	square meters	1.2	square yards	yd ²
km ²	square kilometers	0.4	square miles	mi ²
ha	hectares (10,000 m ²)	2.5	acres	ac
MASS (weight)				
g	grams	0.035	ounces	oz
kg	kilograms	2.2	pounds	lb
t	tonnes (1000 kg)	1.1	short tons	st
VOLUME				
ml	milliliters	0.03	fluid ounces	fl oz
l	liters	2.1	pints	pt
l	liters	1.06	quarts	qt
l	liters	0.26	gallons	gal
m ³	cubic meters	35	cubic feet	ft ³
m ³	cubic meters	1.3	cubic yards	yd ³
TEMPERATURE (exact)				
°C	Celsius temperature	9/5 (then add 32)	Fahrenheit temperature	°F

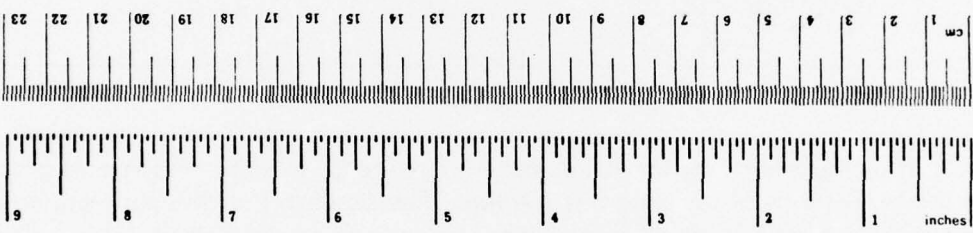

* 1 in = 2.54 exactly. For other exact conversions and more detail tables, see NBS Misc. Publ. 286, Units of Weights and Measures, Price \$2.25, SD Catalog No. C-1310-230.

TABLE OF CONTENTS

		PAGE
I	SUMMARY AND CONCLUSIONS	1
II	INTRODUCTION	2
III	HOUGHTON GLIDE-SLOPE MEASUREMENTS	3
IV	EXPERIMENTAL GLIDE SLOPE	3
V	GLIDE-SLOPE DATA	8
VI	FLIGHT CHECKS	13
VII	GLIDE-SLOPE CAPTURE MONITOR	17
VIII	ACKNOWLEDGEMENTS	26
IX	APPENDICES	39
	A. RF Signal Strength and DDM Meter	39
	B. Houghton Runway 25 Cross Section from G/S Mast to GSCM	44
	C. Path Angles Reported by Minneapolis Flight Inspection	45

LIST OF FIGURES

Figure 1.	Experimental Glide-Slope Transmitter Building and Antennas for Null-Reference System.	4
Figure 2.	Aerial View of Experimental Null-Reference Glide-Slope Site on Runway 25 at Houghton County Memorial Airport, Michigan.	5
Figure 3.	Houghton Integral Monitor Schematic.	6
Figure 4.	Experimental Site Layout.	7
Figure 5.	Elevation Angle and Width by Pattern B - Runway 25, Houghton County Michigan, May 4, 1976.	9
Figure 6.	Ohio University Reference Data - Pattern A, May 4, 1976.	10
Figure 7.	Plot of MTU Discrete Path Data for a Snow Depth of 30.2 Inches.	11

LIST OF FIGURES (CON'T)

		PAGE
Figure 8.	Path Angle Measured by Aircraft Vs. Snow Depth - Houghton County Michigan, Winter 1975-76.	12
Figure 9.	Path Angle by Tower at Threshold Vs. Snow Depth - Houghton.	14
Figure 10.	Snow Depth Profile, Antenna to Threshold Centerline on Runway 25, Late February 1976.	15
Figure 11.	Measured Width Angle (by Aircraft) Vs. Snow Depth - Houghton.	16
Figure 12.	Photograph of Glide-Slope Capture Monitor at Runway 25, Houghton.	18
Figure 13.	Schematic of Glide-Slope Capture Monitor.	19
Figure 14.	Capture Monitor CDI Vs. Glide-Slope Angle by Flight Check - Runway 25, Houghton.	21
Figure 15.	Received Voltage at GSCM Vs. Path Angle by Aircraft.	22
Figure 16.	DDM at GSCM Vs. Path Angle by Aircraft.	23
Figure 17.	GSCM CDI Vs. Path Angle by Aircraft (Pattern A) for all Antennas Lowered in 1' Increments.	24
Figures 18 - 29.	Examples of GSCM CDI and Snow Depth Vs. Time at International Falls, Hibbing, and Minneapolis.	27-38
Figure A-1.	RF Measuring Circuit.	40
Figure A-2.	Precision Audio Processing Circuit.	42

LIST OF TABLES

Table 1.	Compilation of GSCM. Flight and Snow Data.	25
Table A-1.	RF Input Vs. DC Output.	43
Table A-2.	Measured CDI Vs. Calculated CDI.	43

I. SUMMARY AND CONCLUSIONS

The work reported in this document is the first ever accomplished yielding detailed data from an image glide slope operating with an undisturbed, deep layer of snow on the reflecting plane. Whereas previous experiments involving snow cover effects on glide-slope performance had involved undisturbed layers less than 12 inches in thickness or occasional layers up to 24 inches which were quickly plowed, data presented here indicates effects of a continuous, deep layer having a maximum depth of 36 inches. This report is submitted to meet the requirements of Contract DOT-FA76WA-3764 between the Federal Aviation Administration and Ohio University with Michigan Technological University as an associate. The report is effectively one of a series on snow effects on glide slopes, the previous one being FAA-RD-75-210, dated August 1975.

Continual surveillance of a specially installed null-reference, glide-slope facility with deep snow present, using both airborne and ground-based type measurements, has yielded quantitative data which along with previous investigations leads to the following conclusions:

1. The path in space as seen by a user aircraft is well-behaved and performs as predicted by theory. In other words, no strange or anomalous conditions were found to occur.
2. The glide-slope angle measured by use of an aircraft, tracked by a theodolite, was found to increase approximately 0.1 degree for each 12 inches of snow. This is perfectly consistent with measurements made in previous years with less snow.
3. The path width, measured by aircraft in level flight with theodolite tracking, shows a broadening of 0.03 degree per foot of snow which is insignificant.
4. No deterioration of clearances was observed.
5. Snow banks created alongside the runway by plowing of the runway does have an effect on the path angle and structure at the threshold. Raising of the path is observed along with some path roughness in the region just outside the threshold.
6. There is no carefully observed evidence that glide-slope angle lowers significantly with snow.
7. Evidence from Albany, New York indicates that if non-linearities are present in the vertical structure of the path as evidenced by reversals due to terrain irregularities, then it is possible to have an effective lowering of the angle if the on-course is affected by the reversal. In effect, the snow moves the path angle upwards, but due to the reversal in the vertical structure, the path angle is actually seen to lower. The possibility of this occurring in practice can be eliminated by scrutinizing the vertical structure of the path on commissioning and insuring that significant reversals do not occur.
8. The far-field, capture-effect monitor has been found to have modest correlation with path performance, but further refinement is needed especially with the operational procedures before it can be used with confidence for assessing path performance.

II. INTRODUCTION

Each year over the past decade serious efforts have been made to acquire full scale glide-slope data which reveals performance of the image glide slope during periods when deep snow layers exist on the reflecting plane serving the system. Historically, it has been found that many questions concerning glide-slope operation have been raised due to several factors. First and foremost, the near-field monitors which are sometimes tacitly accepted as revealing far-field performance do not, in fact, predict far-field conditions. Because the near-field monitor frequently shows out-of-tolerance conditions when layers of snow greater than 12 inches exist thus shutting the facility down, far-field measurements were not made since most everyone assumed the far-field was out-of-tolerance. Data obtained over the past several years shows this is clearly not the case, so a more careful investigation is justified.

A second factor which encourages a more extensive investigation of snow effects is the recent installation of many more glide slopes in areas where heavy snowfall is experienced.

Finally, an investigation of snow effects is encouraged and justified by the increased air traffic and the advent of the high performance jet aircraft. These aircraft require precise vertical guidance during an approach for maximum safety; hence, a glide slope is a very valuable aid even under good weather conditions. Obviously a glide slope removed from service because of monitor sensed conditions only, degrades safety.

A multifaceted work effort has been completed to obtain data on null-reference glide-slope angle, width, and clearance response to deep snow covers on the ground plane and to investigate means of monitoring these path parameters. To accomplish this, four rather discrete tasks were performed. First, an experimental null-reference system was established at the Houghton County Memorial Airport in northern Michigan. This was the first time an instrumented site was operated in a deep snow area where plowing would not take place. Second, two-frequency, capture-type far-field monitors specially constructed by the FAA Aeronautical Center, Oklahoma City were installed and operated at Houghton, Michigan, Hibbing, Minneapolis and International Falls, Minnesota in order to determine if this type of far-field monitoring could provide maintenance personnel useful information concerning path conditions in space. Third, special flight measurements were made by FAA NAFEC team, by Ohio University, by FAA FIFO Minneapolis and by Michigan Technological University. Fourth, a separate activity provided for processing monitor data obtained by Airway Facilities Service from five field locations over the winter. This has permitted establishing a data base in computer machine format which can be used for a variety of purposes, not the least of which is to determine the statistics of outages. This work which received separate funding will be reported in the final report for Contract DOT-FA75WA-3549 work effort.

III. HOUGHTON GLIDE-SLOPE MEASUREMENTS

Under this work effort an experimental null-reference glide slope established at 330.8 MHz on Runway 25 Houghton County Michigan Airport, was used for measurements beginning in January 1976. The commissioned glide slope on Runway 31 was not used for measurements because of snow plowing which was continually in progress (see Figure 1). This experimental glide slope allowed measurements to be taken with a ground plane snow cover which was allowed to build naturally ahead of the transmitting antennas. Also, considerably more latitude could be allowed in testing and performing measurements with the experimental system as opposed to the commissioned facility.

The purpose of the tests made on the experimental system was threefold. More data was desired concerning the far-field path angle and width values particularly under conditions where the reflecting ground plane snow cover was undisturbed. Also, data was needed to determine whether the increasing snow cover depth has a degrading effect on the below-path clearance. Finally the experimental glide slope provided the best available controlled test site for evaluating the performance of the far-field glide-slope capture monitor (GSCM). To this end data was taken in the field from January to May 1976 by personnel from Michigan Technological University (MTU) at Houghton, Michigan and to a lesser extent by Ohio University personnel.

IV. EXPERIMENTAL GLIDE SLOPE

A Mark I-C glide-slope system was rented from Wilcox Electric Inc., by MTU. A standard 3.0-degree, null-reference path was set up using calculated antenna heights, taking into account the slope of the ground plane. An aerial view of the site is shown in Figure 2. Since at the time of initiation of this program and installation of the system there were approximately 21 inches of snow on the ground, the on-path 180 degree near-field monitor could not be properly positioned, so it was not used for data collection. The transmitter signals were monitored with two channels of integral monitoring to simulate far-field on course and 0.7 degree below-path DDM conditions. See Figure 3 for a schematic of this monitor. Throughout the data collection period the integral monitor readings were cross-checked with independent measurement of transmitter parameters such as carrier and sideband power levels and percent modulation. The transmitted signals from this glide slope proved to be very stable during this period.

Along with all measurements of path angle, width angle and associated glide-slope parameters, snow depth measurements were taken. The snow depth reported is an average of readings from five graduated stakes permanently located at points shown in Figure 4 with site contours.

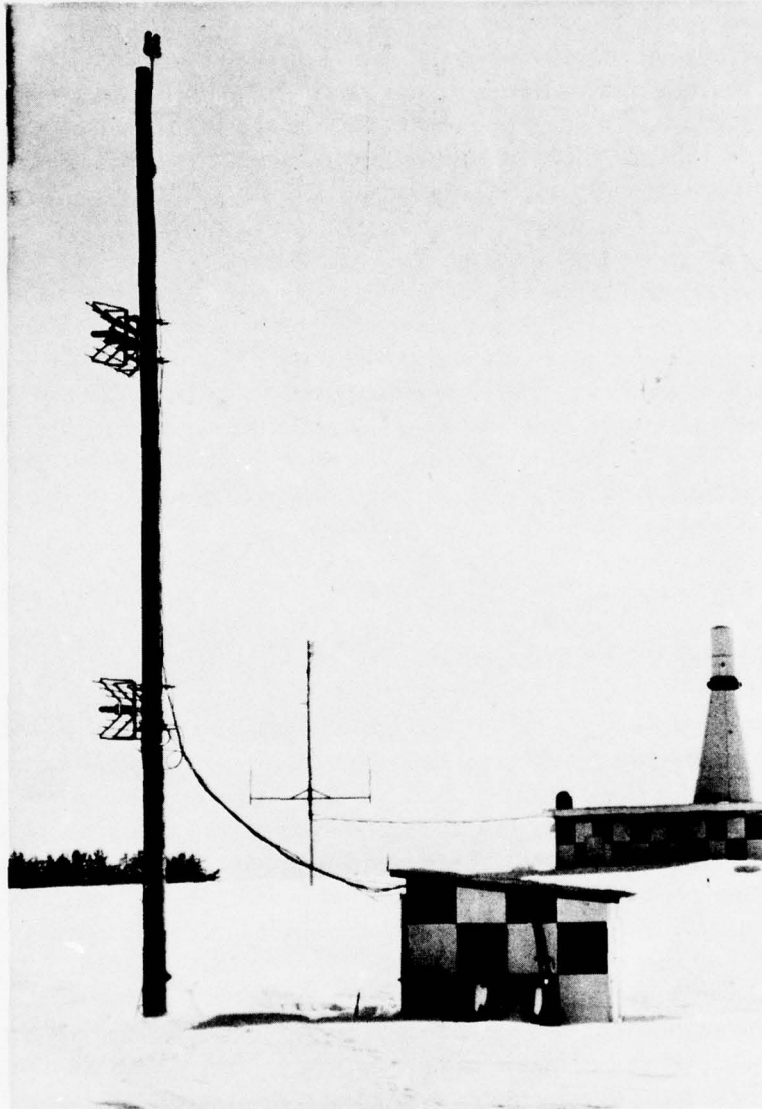

Figure 1. Experimental Glide-Slope Transmitter Building and Antennas for Null-Reference System. Note VORTAC installation to the side of the glide-slope facility. This station has been found useful during flight checks for providing distance information. Flight checks on the VOR have shown that no interference is created by the glide-slope structures.

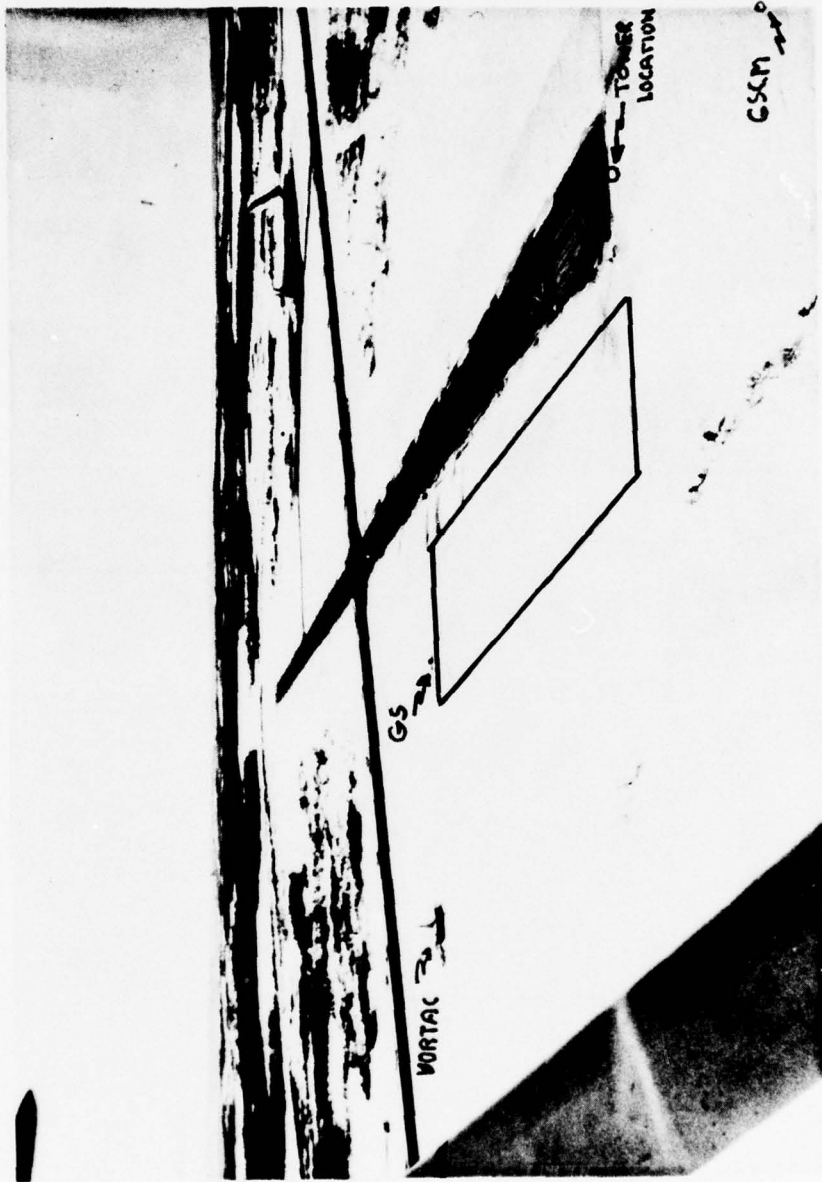

Figure 2. Aerial View of Experimental Null-Reference Glide-Slope Site on Runway 25 at Houghton County Memorial Airport, Michigan. The area of the reflecting plane is outlined.

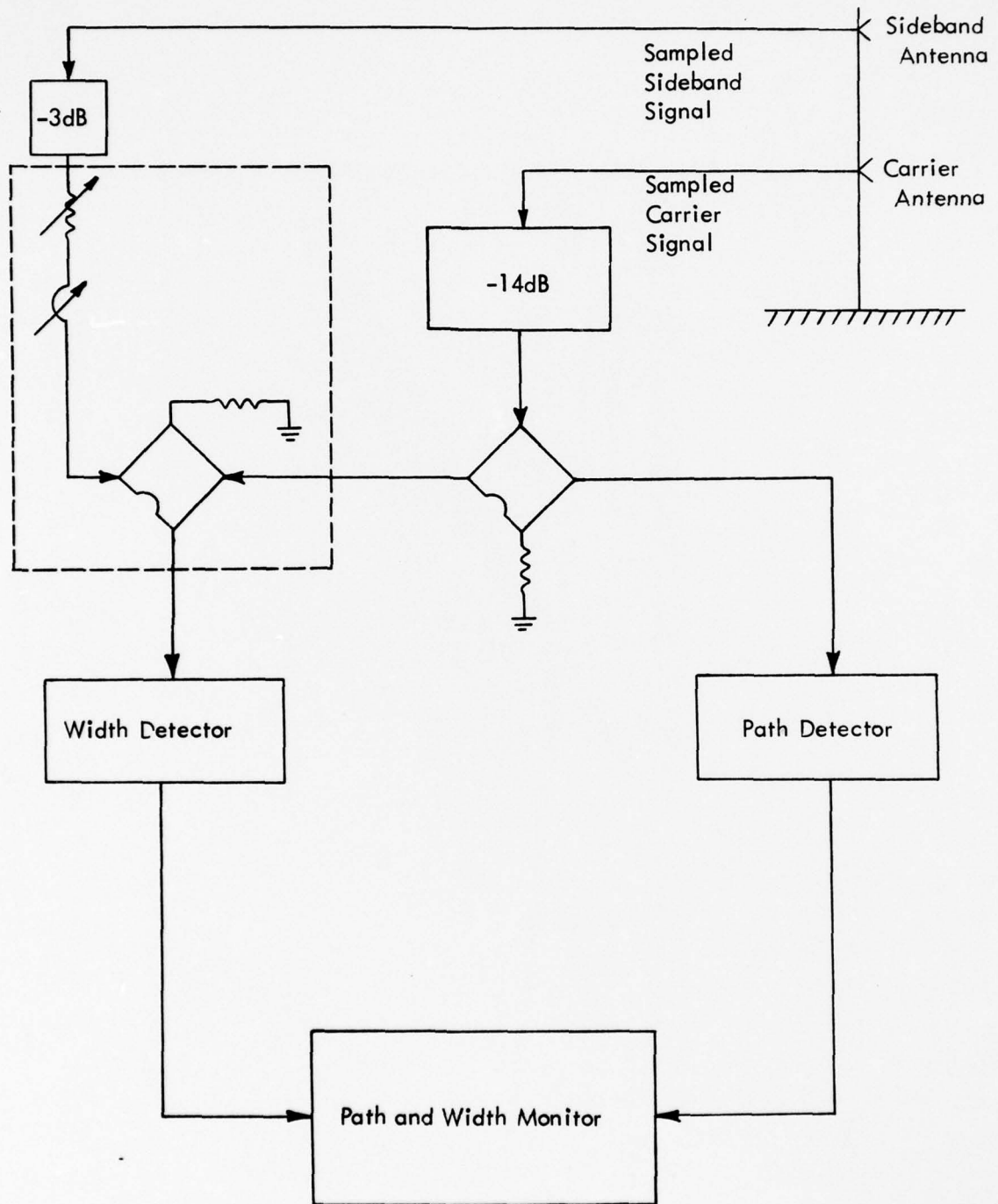

Figure 3. Houghton Integral Monitor Schematic.

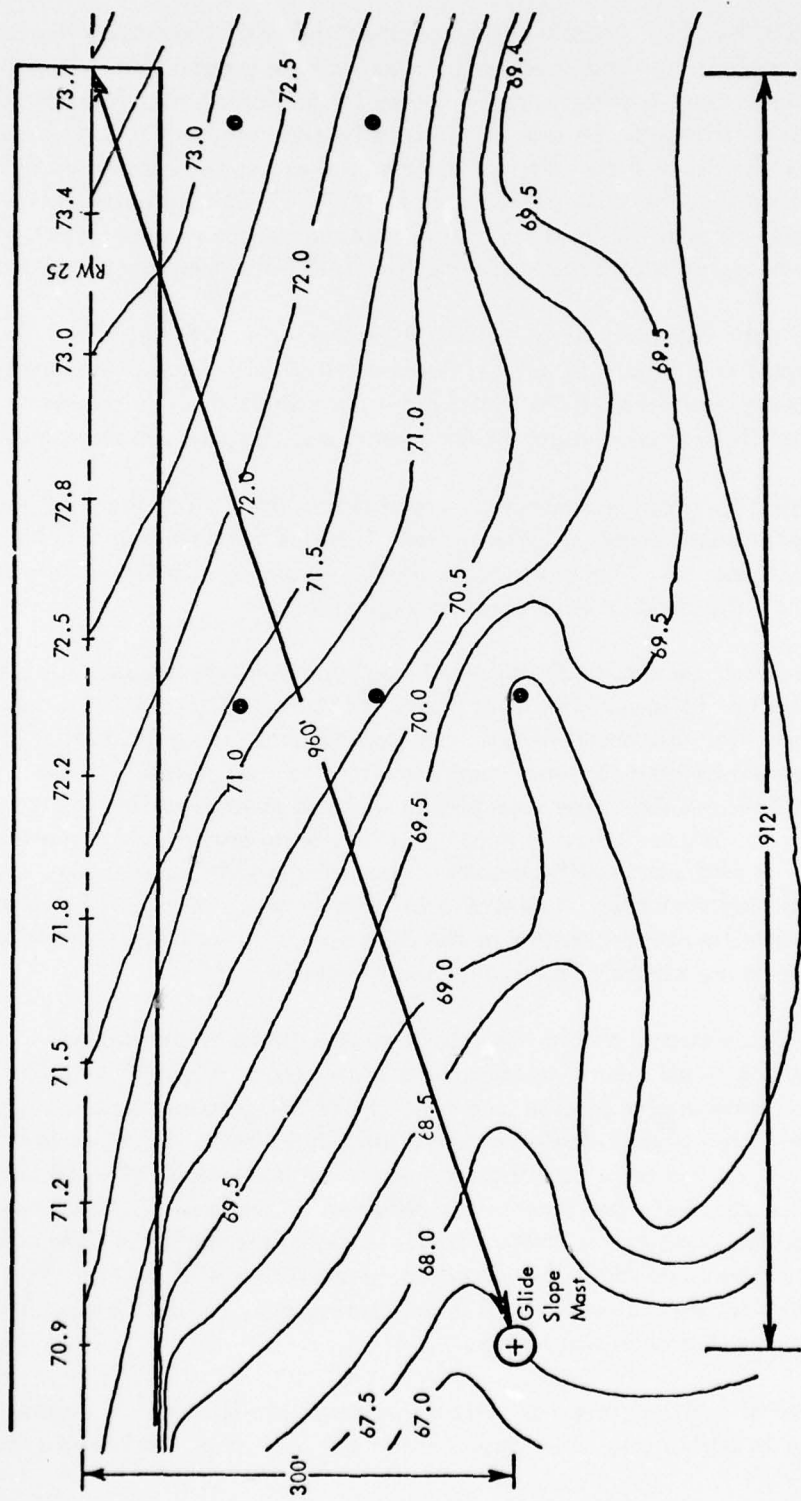

Figure 4. Experimental Site Layout. Position of snow measurement stakes are marked with a dot.

V. GLIDE-SLOPE DATA

This data collection program was not authorized until December; hence, it was not possible to acquire base-line, reference data for bare ground until after the snow data had been collected. Snow depths were 21 inches for beginning of measurements in January 1976, peaking at 34 inches on March 15 and finally exposing bare ground in mid-April. A very useful set of data of snow effects was obtained as the snow depth diminished relatively rapidly during the thaw period. Final flight check reference data was taken by Ohio University on May 4, 1976. Data on antenna height change effects was obtained in mid-May for the purpose of calibrating the far-field, two-frequency monitor.

Nominal path values found by Ohio University were path angle = 3.08 with a width of .69 degree (see Figure 5) using a Beechcraft 35 with a mini-lab recording package. Discrete measurements by MTU indicated a path angle of 3.06 degrees. Standard deviations for the discrete path angle measurements was .03 and .06 degree on two runs.

From Figure 6, showing a nominal recorded run, it is clear that the path has two rather discrete path angle regions. When inside $1\frac{1}{2}$ miles the path angle is found to increase approximately 0.1 degree. This is undoubtedly due to changes in the ground-plane level and is supported by the contour data given in Figure 4.

Discrete data, which was the predominate type collected during the winter by MTU, was acquired as follows. The aircraft flew a Pattern A (normal low approach for landing) and when the crew observed a zero microampere reading on their specially-calibrated equipment readout, a tone was transmitted to the ground. At that instant an observer would record the value seen on the scale of the theodolite being operated by a second person. The sequence of numbers would be averaged and a standard deviation value obtained. A plot was usually prepared also using a time base of data acquisition to represent the distance variable. A plot of such data is given in Figure 7. This is typical Pattern A data with the random scatter of the data points as well as the trend of the path angle to increase as the aircraft approaches the threshold.

As stated previously, one of the principal objectives of the project was to determine the effect of the unplowed ground plane on the path angle. Figure 8 provides Pattern A average measured path angles plotted as a function of the ground-plane average snow depth. A solid line, which has been calculated to have the least mean square error from the points measured, is drawn on the same coordinates. This line has a slope of 0.10 degree per foot of snow. This is very nearly the same result obtained in past years. The computer routine used to calculate the coordinates of the best fit straight line for these data points also was used to calculate a square root of the mean square deviation of the points from this line. The RMS deviation for the pattern A runs is calculated to be 0.035 degree, thus providing a measure of the scatter of the points.

MTU data of path angle by an aircraft versus range is shown in Figure 7. Note that the increase in path angle when approaching the airport is consistent with baseline data.

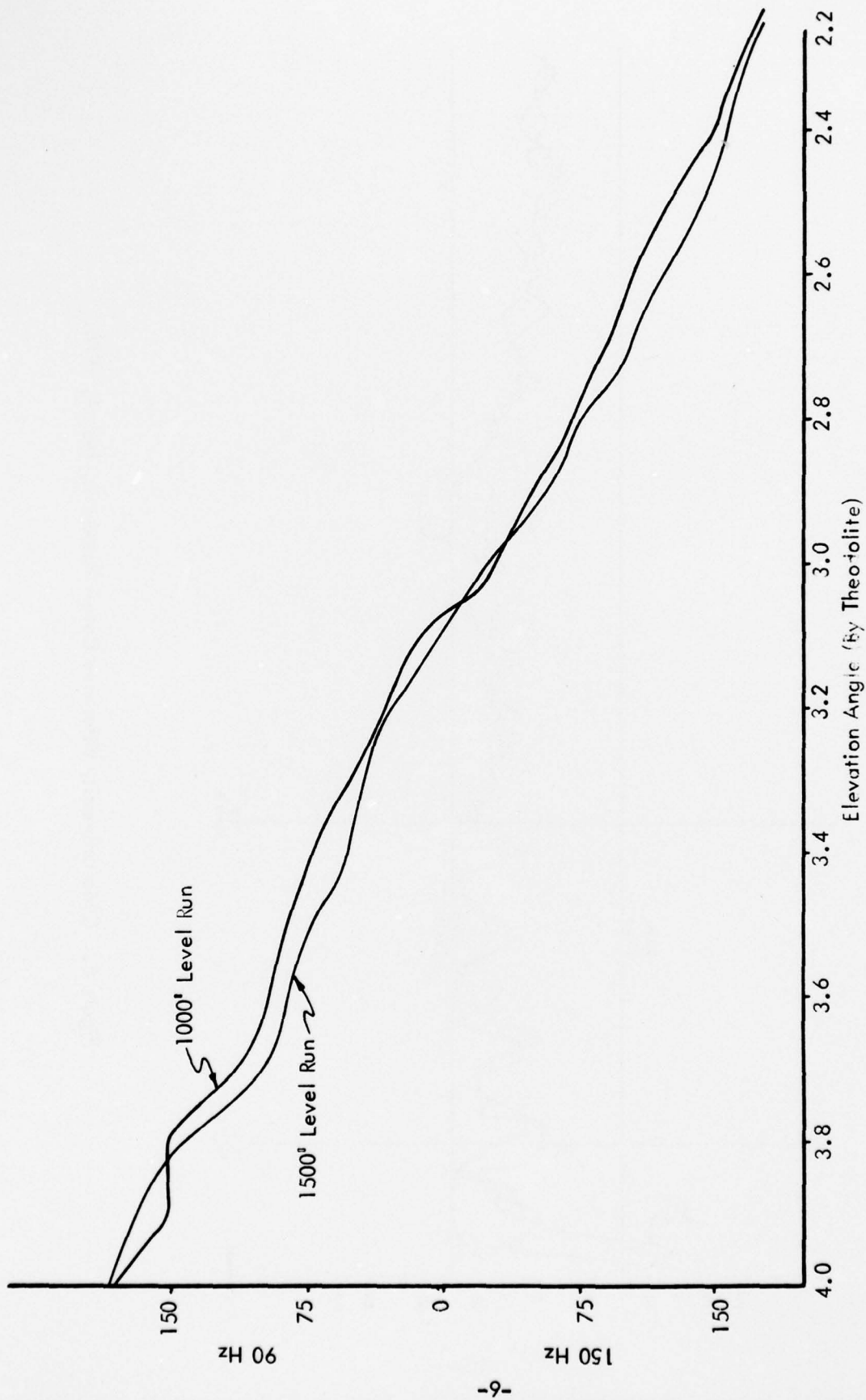

Figure 5. Elevation Angle and Width by Pattern B - Runway 25, Houghton County Michigan, May 4, 1976.

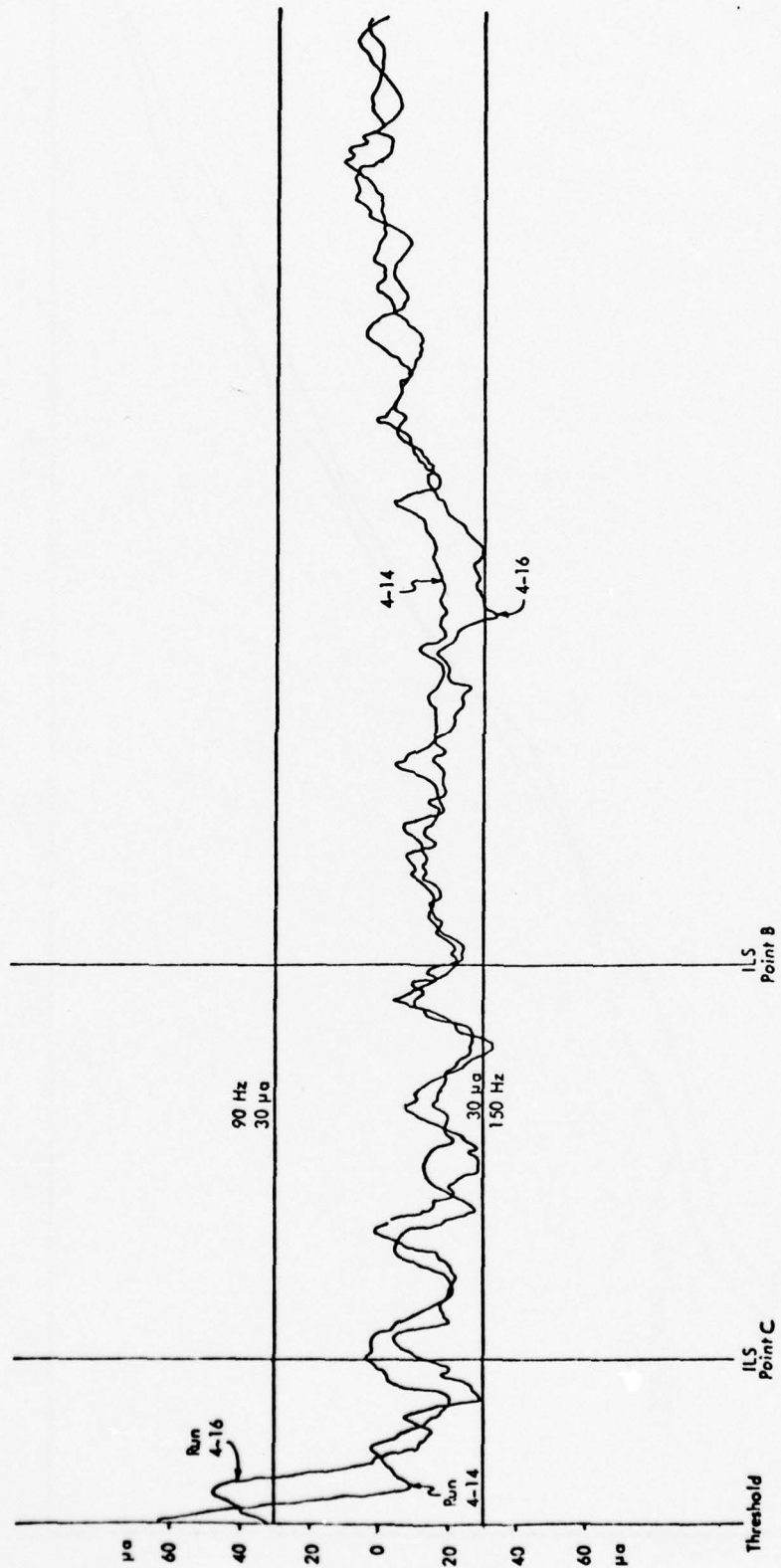

Figure 6. Ohio University Reference Data - Pattern A, May 4, 1976.

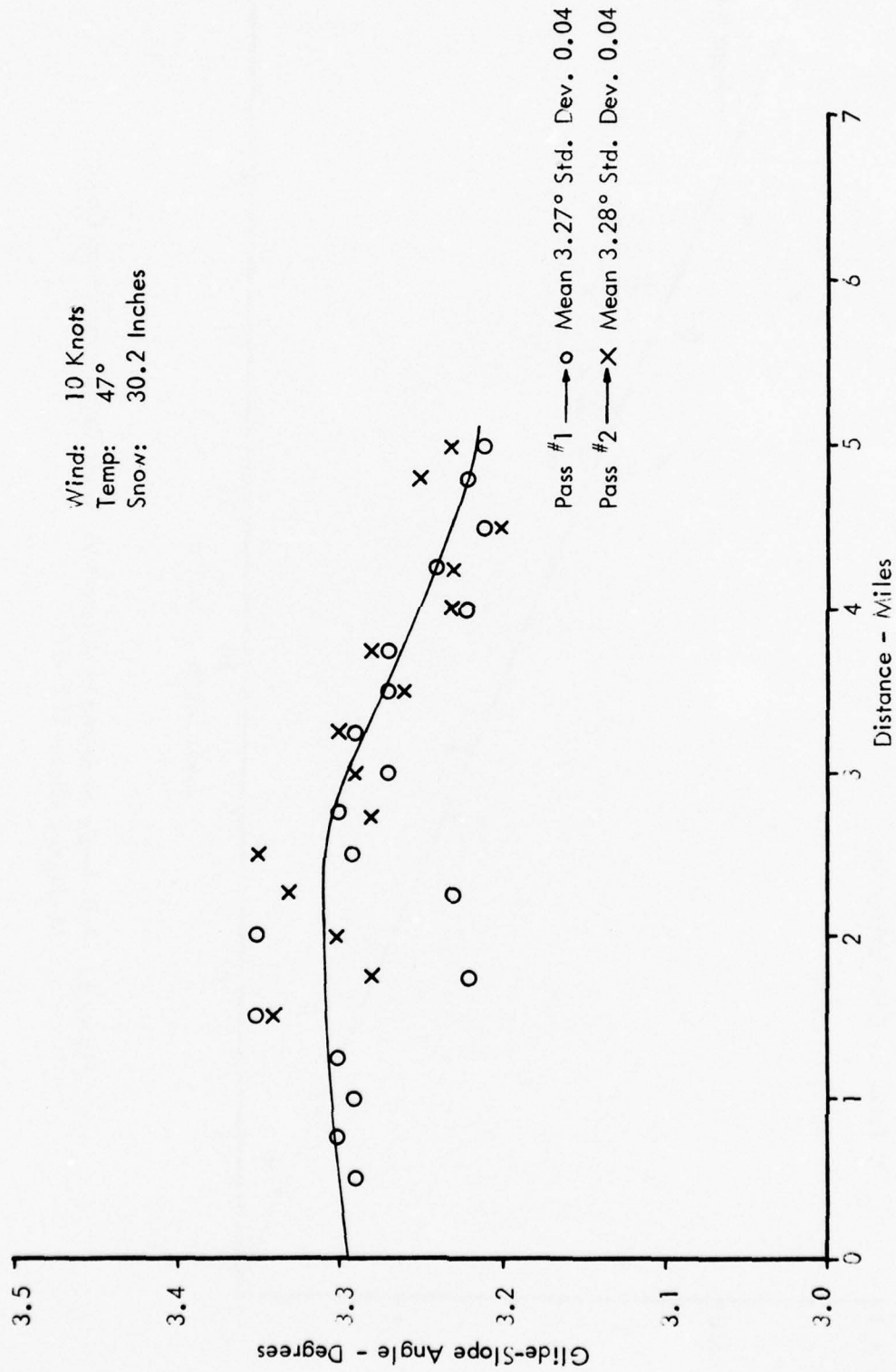

Figure 7. Plot of MTU Discrete Path Data for a Snow Depth of 30.2 Inches - Runway 23, Houghton County Michigan, February 24, 1976, from Aircraft.

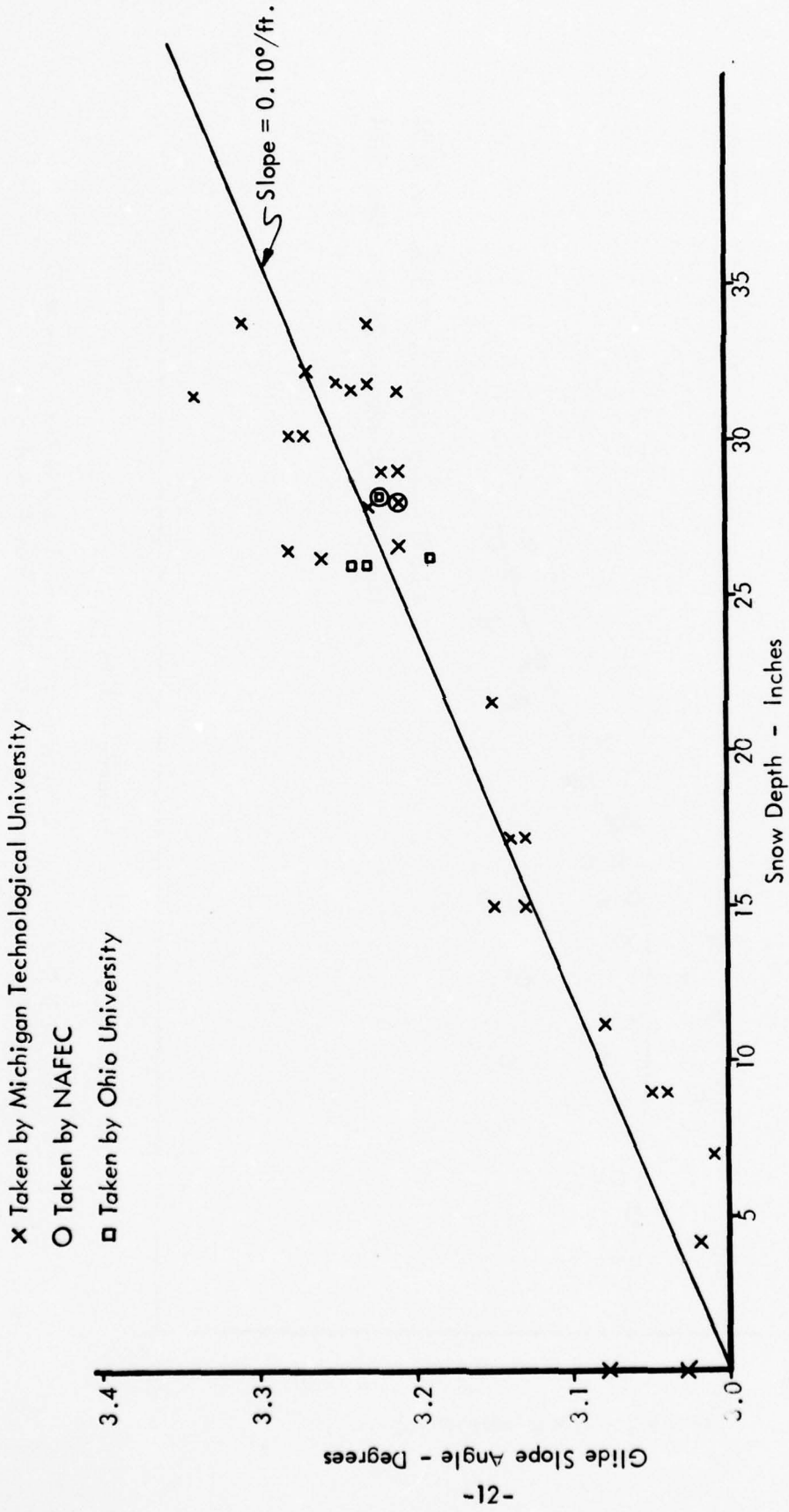

Figure 8. Path Angle Measured by Aircraft Vs. Snow Depth - Houghton County Michigan, Winter 1975-76.

The glide-path angle measured with the extendable tower at the runway threshold is shown plotted against snow depth in Figure 9. The slope of the best fit straight line is again 0.10 degree per foot of snow. The scatter of points yields an RMS error of 0.058 degree from the straight line. Interestingly, many possible errors one would suspect to occur in the theodolite measurements of aircraft angle do not exist with the tower data, yet the scatter of points is about the same as the Pattern A data. The antenna on the tower is stationary and the angle can be measured very accurately by theodolite. Clearly the average snow depth in the reflection zone does not correlate perfectly with the path angle when the snow cover is not uniform.

Figure 10 depicts the snow depth along a line from the glide-slope antenna to the runway centerline at threshold. It is seen from this figure that although the reflection zone was never plowed, the plowing of the runway caused an increase in snow depth near the runway edge. It seems certain that this condition contributed strongly to the path angle measurements with the tower being consistently higher than the far-field, and to the scatter of the data points. It is important to note that localized conditions of the snow surface caused by plowing or other activity may well affect the path angle especially at the threshold. This should be a consideration in making snow removal policies.

Figure 11 is shown in order to illustrate that the snow cover had little effect on the width angle as measured by Pattern B flights. The best fit straight line indicates that on the average the measured width increased about 0.026 degree per foot of snow, which is trivial. The RMS deviation of the data points is less than 0.04 degree. The Pattern B flight data indicate that the clearance tends to remain essentially constant with snow buildup. The parameter most likely to affect the width or clearance is the relative phase between the sideband only and carrier sideband fields at the receiving antenna. This phase relationship was checked at various times during the year by the quadrature phasing method and found to vary less than ± 8.5 degrees from the original setpoint. In theory, therefore, it appears from this set of data that the width is constant under snow conditions. According to theory, changing the phase of a standard null-reference glide slope by ten degrees would only change the width angle by 0.01 degree.

VI. FLIGHT CHECKS

Because the user aircraft is of primary concern when considering glide-slope parameters, it is necessary that much of the determination of glide-slope values be made in the far-field. The most practical and representative means for doing this is by use of an instrumented aircraft referenced in space by means of a theodolite. Aircraft from FAA, MTU and Ohio University were used in data collection. In all cases, the airborne equipment underwent special calibrations to minimize error.

Two basic types of flight patterns were flown to gather data from this glide slope. A "Pattern A" is defined as a low approach typical of an approach to landing. From these the average far-field path angle was determined referencing the theodolite.

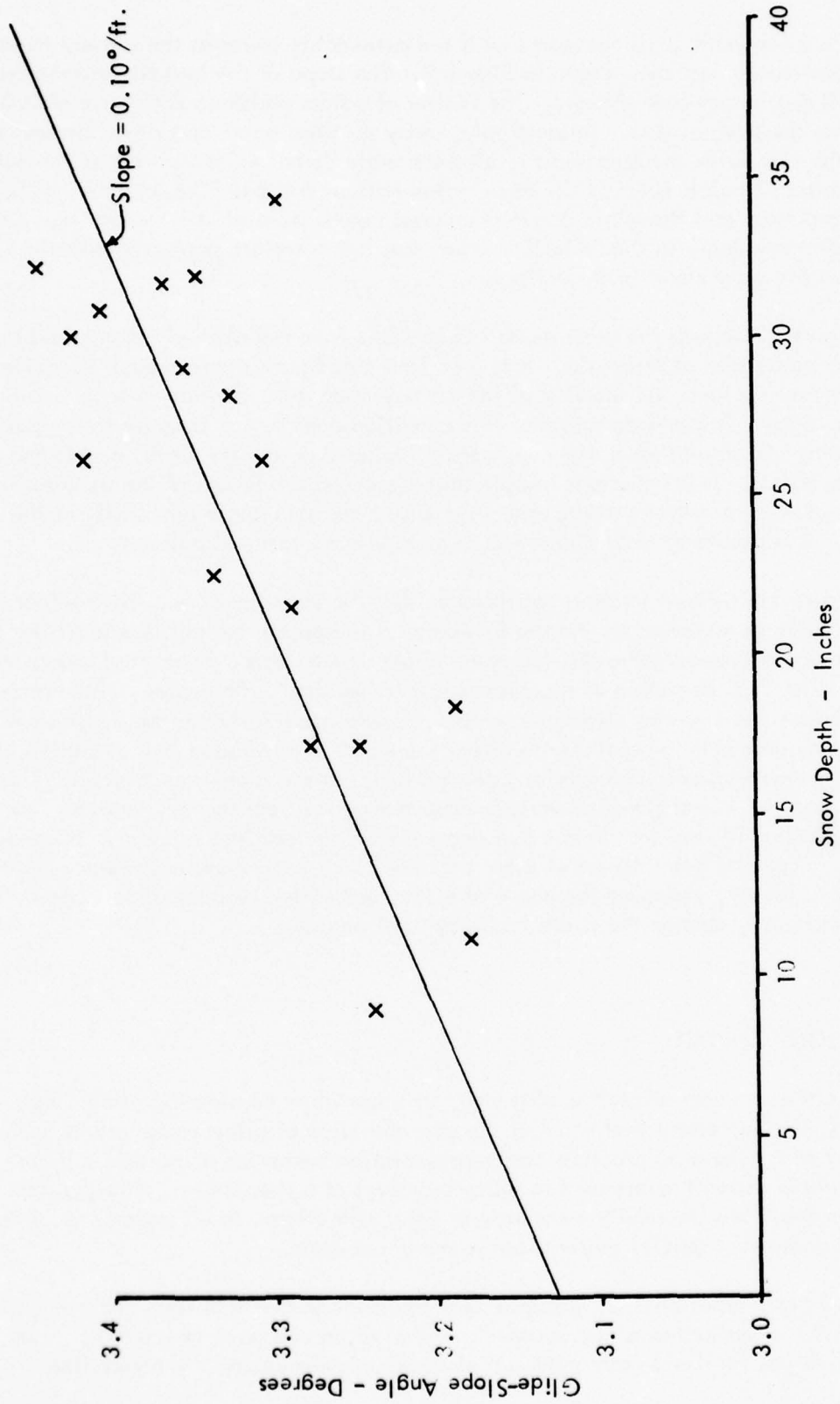

Figure 9. Fath Angle by Tower at Threshold Vs. Snow Depth - Houghton County Michigan, Winter 1975-76.

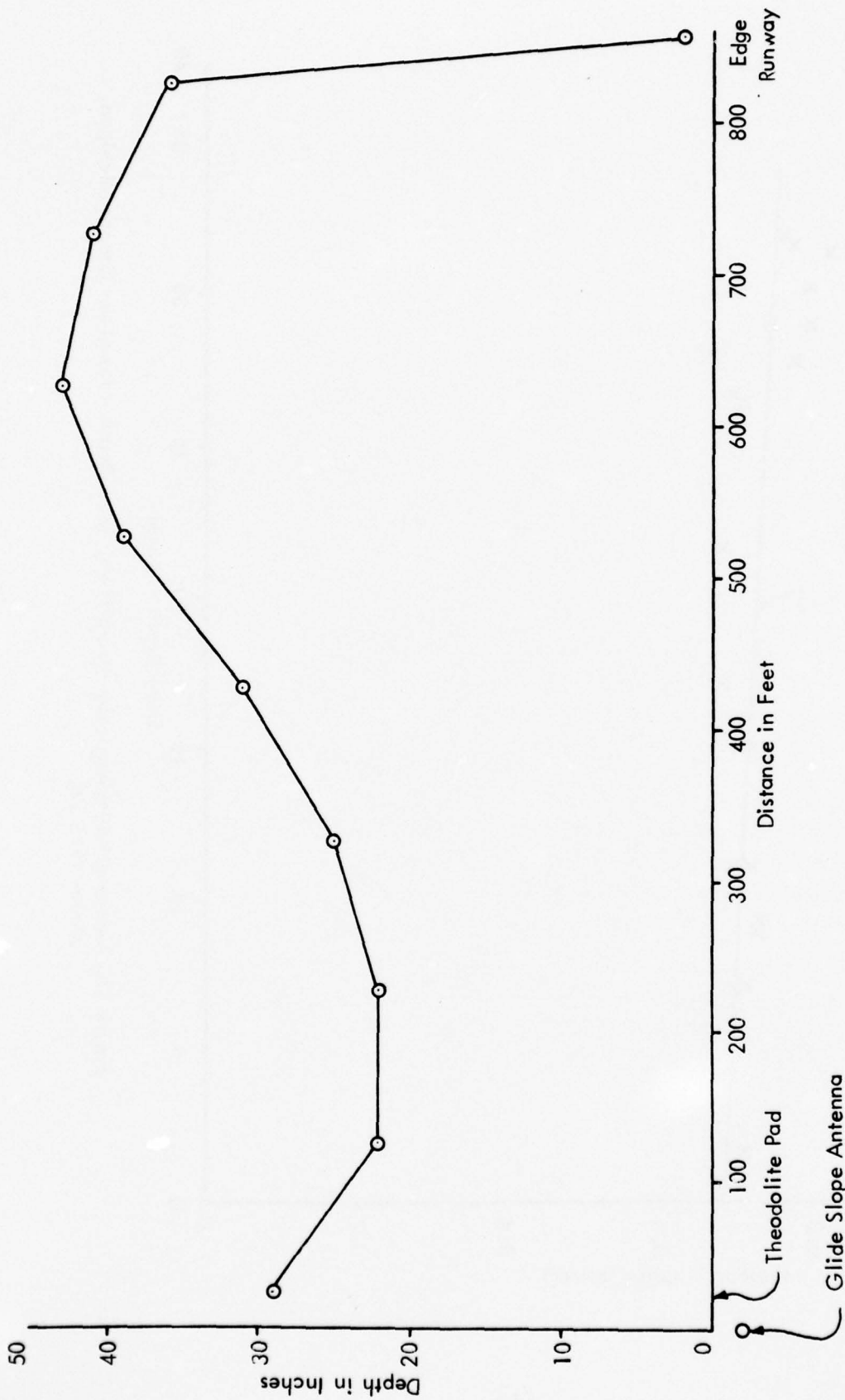

Figure 10. Snow Depth Profile, Antenna to Threshold Centerline on Runway 25, Late February 1976.

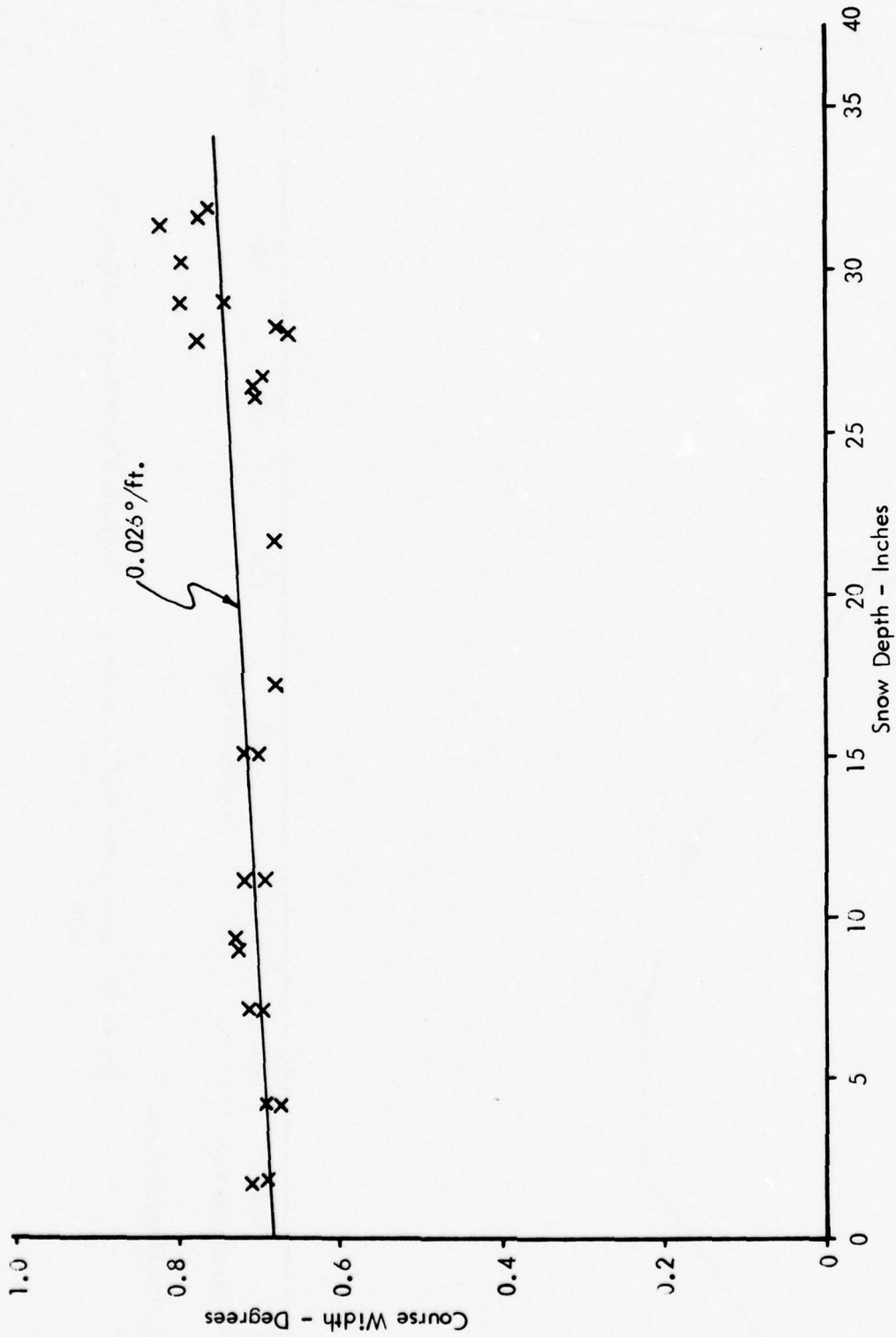

Figure 11. Measured Width Angle (by Aircraft) Vs. Snow Depth - Houghton County Michigan, Winter 1975-76.

"Pattern B" is a flight pattern at a constant elevation (usually 1000 or 1500 feet) through the glide-slope pattern over the runway centerline extended. Theodolite measurement of the aircraft elevation angle and readings of the CDI (course deviation indicator) current in microamperes enabled CDI versus elevation angle characteristics to be recorded or plotted. From these data it can be seen whether the DDM (difference in depth of modulation - proportional to CDI current) pattern is disturbed by the snow, i.e., whether path angle, width and clearance have been affected. Normally a full scale CDI deflection occurs at 0.7 degree below the path (2.3 degrees with a 3.0 degree path angle). The normal ± 0.2 degree tolerance would mean that during snow conditions the full scale deflection should not occur at an angle below 2.1 degrees.

Good visibility is, of course, required for accurate theodolite tracking, and winter weather does not always provide the necessary conditions for good flight checks. As a backup measuring system, an extendable tower with a dipole receiving antenna attached was used to probe the transmitted signal at the runway threshold. These measurements could be taken under much worse weather conditions than those required for the flight check.

Measurements of the path with the tower have shown consistently higher angles than measurements made by aircraft. This is due to two factors. Raising the reflecting plane with a given number of inches of snow will offset the path coordinate system upwards by that amount* and will increase the angle due to reduced spacing of the real and image sources. In the far-field the effect of the coordinate shift is negligible, while at threshold the offset results in a noticeably higher angle measured by the theodolite. Terrain effects account for most of the remainder of the difference in the two measurements.

VII. GLIDE-SLOPE CAPTURE MONITOR

In addition to two Houghton sites, the glide-slope capture monitor (GSCM) was installed at Runway 4 at Minneapolis, Hibbing and International Falls, Minnesota this winter. Because of the extensive number of flight checks, the Houghton facility offered by far the best opportunity for evaluation. The airborne path angle measurements allowed the monitor readings to be compared directly with the path angle which is the parameter of interest. Figure 12 shows the Houghton Runway 25 glide-slope capture monitor installation. A block diagram of the GSCM used at all four facilities appears in Figure 13. The yagi antenna receives the glide-slope signal well below path and receiver #1 detects this signal extracting the 90/150 Hz audio signal. This is then applied to the phase-locked loop 90 Hz generator. The phase-locked loop 90 Hz generator produces a pure 90 Hz only tone in phase with the received 90 Hz tone for modulating the local UHF signal generator. The signal from the UHF generator is added to the received glide-slope signal and fed to receiver #2. This receiver is

*One should note that the reference coordinate system (theodolite) does not change with snow cover.

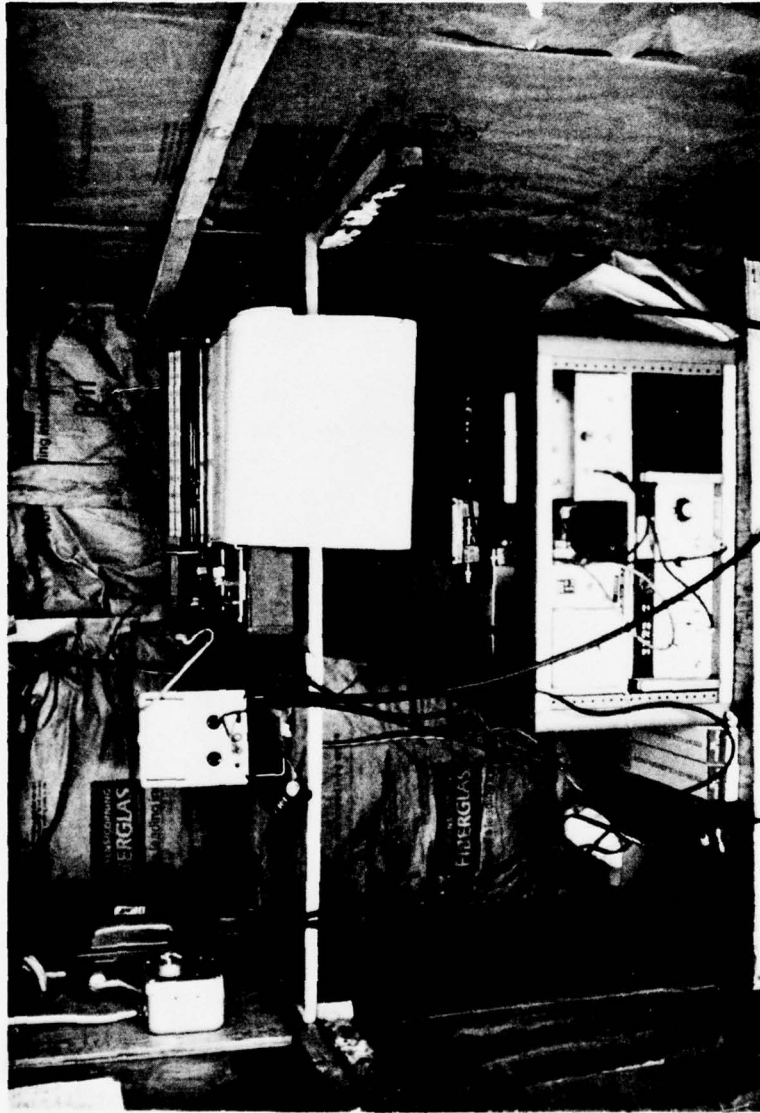

Figure 12. Photograph of Glide-Slope Capture Monitor at Runway 25 Houghton. Except for the recorder this installation is typical of the equipment also used at the Minnesota sites. The hot pen recorders were used to minimize inking problems in the cold weather.

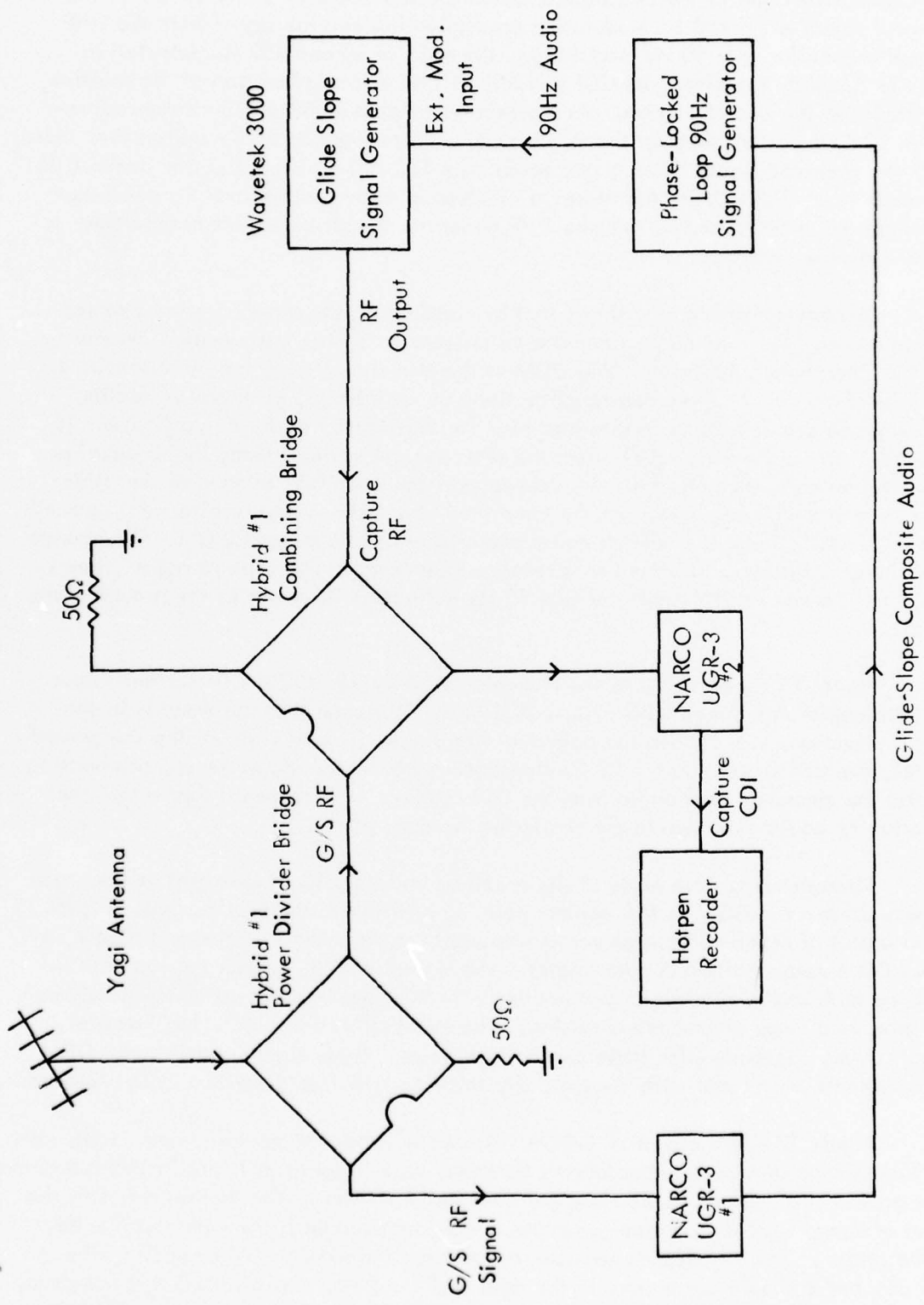

Figure 13. Schematic of Glide-Slope Capture Monitor.

captured by the larger of the two signals which are separated by 14 KHz. Since the received signal has a 150 Hz modulation predominating and the signal from the UHF generator contains only 90 Hz modulation, the ratio of 90 and 150 Hz detected in receiver #2 (and, therefore, its CDI current) will be a strong function of the relative amplitudes of the two RF signals. As the received signal amplitude is decreased, receiver #2 CDI (which reads on the 90 Hz side) will increase its 90 Hz deflection. Also, when the received signal DDM is decreased (less 150 Hz) 90 Hz deflection of the CDI will decrease. The CDI is, therefore, a function of both the received signal strength and received DDM (assuming that the UHF generator output amplitude and percent modulation are constant).

Electromagnetic theory shows that by considering the snow cover as a raised ground plane, new antenna patterns can be calculated taking into account the snow, and that the change in RF level and DDM at the monitor antenna can be determined. Analysis of a standard three degree glide slope on an infinite, perfectly reflecting ground plane provides some insight into how the GSCM may perform in practice. It is found that, as the snow level raises the effective reflecting plane, the RF level at a monitor antenna located at a low angle several thousand feet in front of the glide-slope antennas will decrease. At the same time, the DDM at the monitor will increase (more 150 Hz). These two effects cause opposite reactions in the GSCM. The change in RF level is the more dominant in a receiver operating in the capture region, however, and the net result is that the CDI 90 Hz indication increases as the ground plane raises.

Figure 14 shows a plot of the Houghton Runway 25 GSCM CDI current versus the path angle determined with Pattern A flights. It is seen that the trend is in the proper direction, i.e., when the path angle increases (due to snow raising the ground plane), the CDI current on the 90 Hz side becomes greater. If, however, one were to predict the measured path angle from the CDI reading, it is apparent that significant uncertainty would exist due to the scatter of the data points.

Measurements were made of the received voltage (signal strength) at Houghton Runway 25 and the DDM at the monitor point in addition to the CDI current. Figure 15 shows a plot of received voltage versus measured Pattern A path angles and Figure 16 shows DDM versus Pattern A path angles. The signal strength is seen to drop with increasing path angle which is in accordance with the simplified model which considers the snow as a large ground-plane raising. The DDM plotted in Figure 16, however, seems to vary randomly with little perceptible trend. These signal strength and DDM measurements were made with the specially fabricated device described in the Appendix.

Figure 17 shows a plot of GSCM CDI versus Pattern A measured path angle when all transmitting antennas and receiving antennas were lowered in 1 foot increments above bare ground at Houghton to simulate the snow accumulation. The 46 dBm refers to the level of signal from the capture generator which was used until the very last few days of the season. The -44 dBm value was used to keep the GSCM CDI on scale. The -46 dBm curve should correspond to the data on Figure 14. The agreement is not good, and it may mean that lowering the antennas in this manner cannot properly simulate the accumulation of snow during the winter.

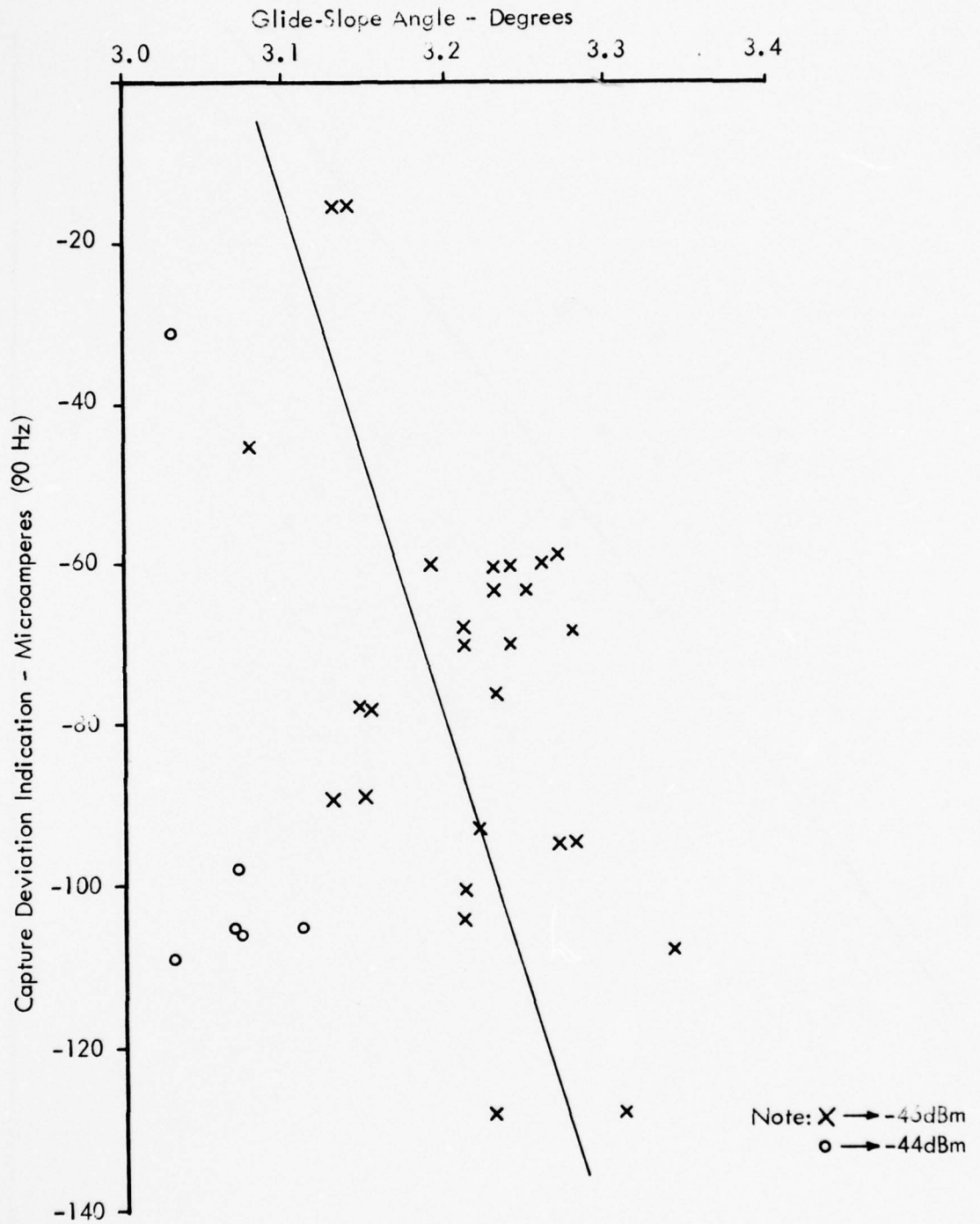

Figure 14. Capture Monitor CDI Vs. Glide-Slope Angle by Flight Check - Runway 25, Houghton County Michigan, Winter 1975-76.

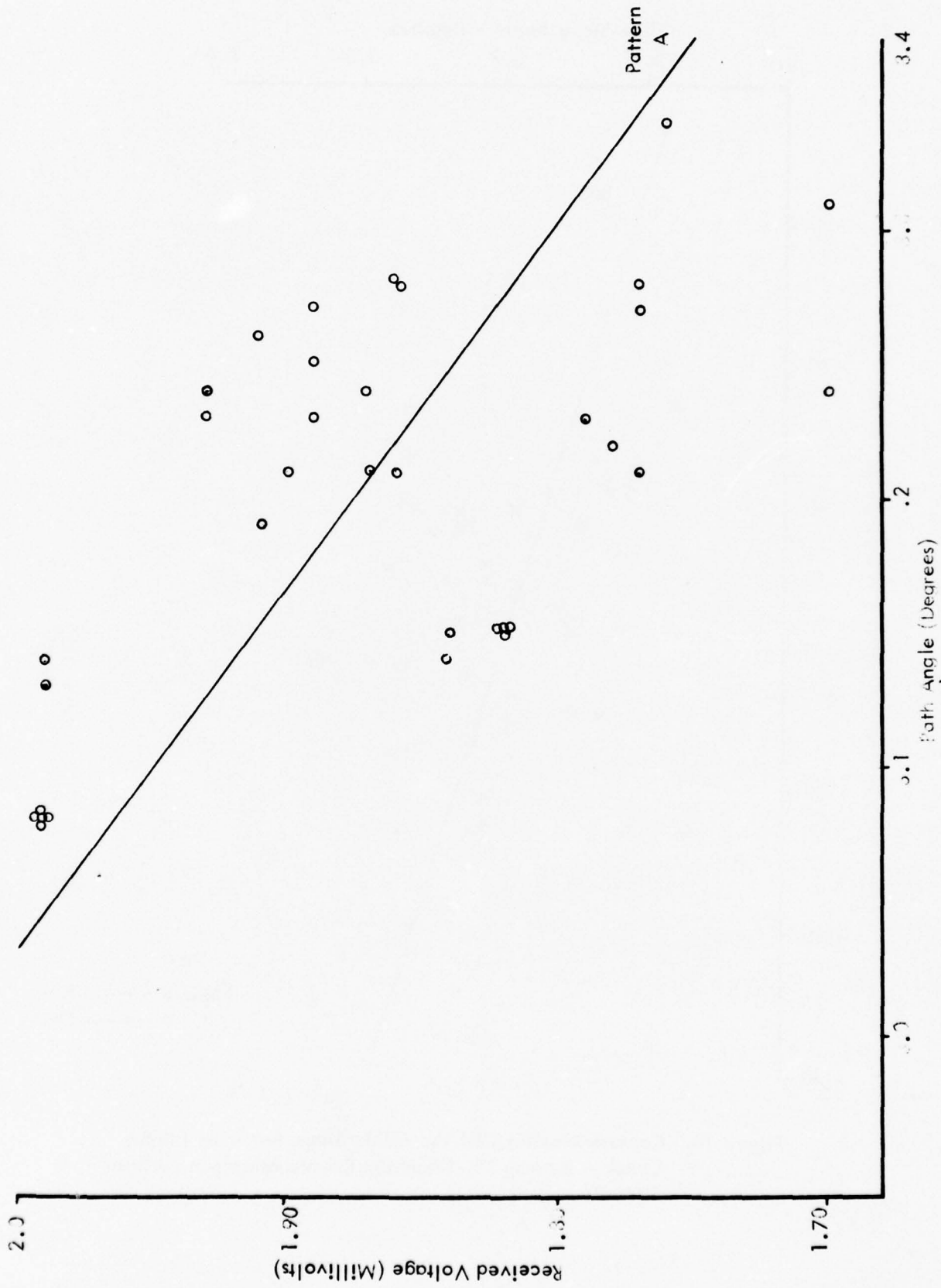

Figure 15. Received Voltage at GSCM Vs. Path Angle by Aircraft. Voltage values obtained from Ohio University signal strength indicator.

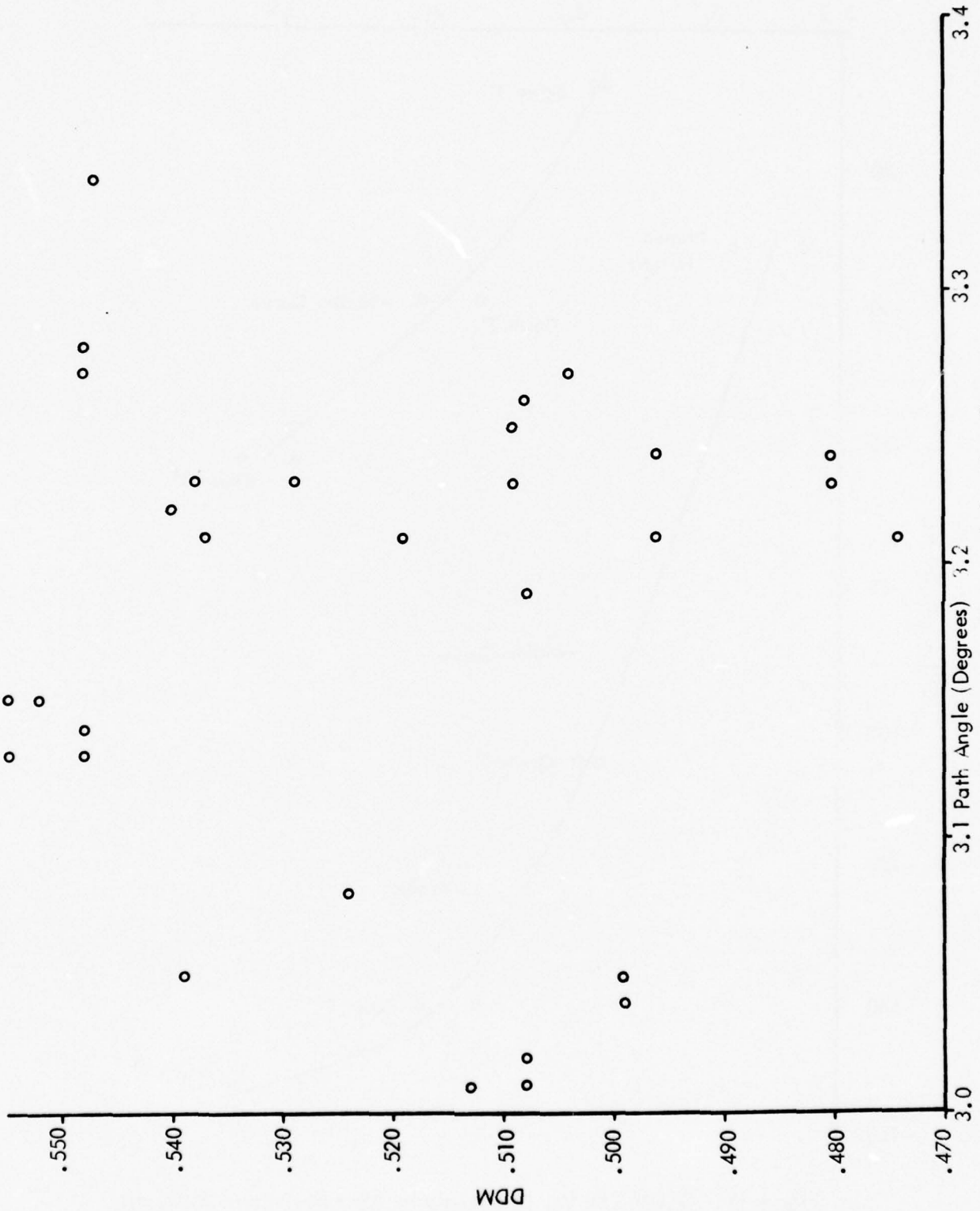

Figure 16. DDM at GSCM Vs. Path Angle by Aircraft.

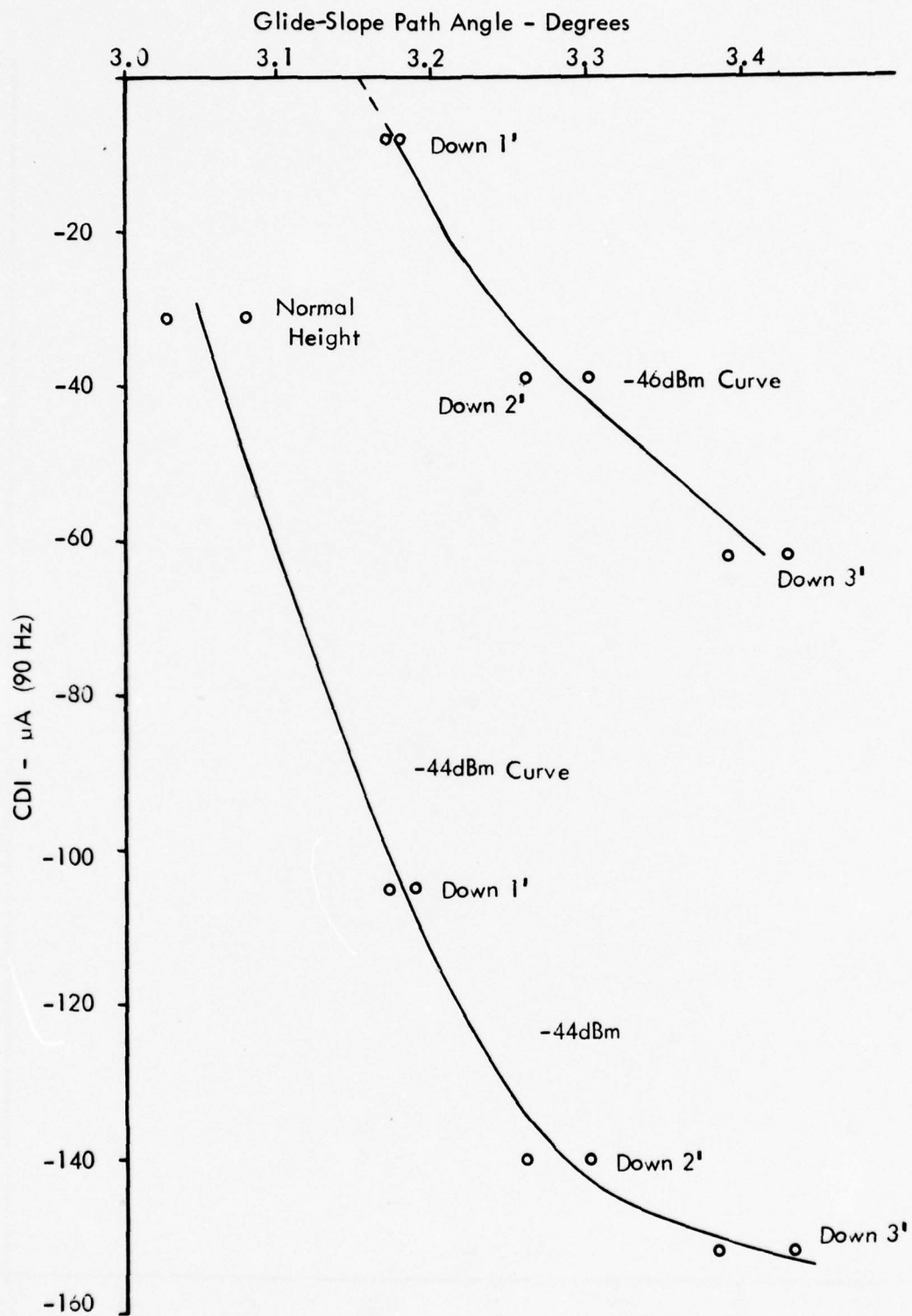

Figure 17. GSCM CDI Vs. Path Angle by Aircraft (Pattern A) for all Antennas Lowered in 1° Increments.

All of the strip chart recordings of GSCM CDI were analyzed from the Minnesota sites, but a number of factors limited the full usefulness of the data. At Minneapolis, Runway 4 ILS was off-the-air much of the time, due to interlock with the ILS on Runway 22, and left concern about calibration and stability of the GSCM system there. Hibbing, and Houghton Runway 31 were plowed several times during the winter, and this left considerable doubt as to what was the representative snow cover. International Falls, together with the other stations, had some variations in carrier power but were within normal and expected values.

Table 1 shows a compilation of discrete GSCM data with snow depth and path angle values determined by flight check. The reader should remember that an increase in snow depth should decrease the electric field intensity at the GSCM resulting in an increase in the CDI value (90 Hz). This should correspond to an increase in path angle.

	Date	Snow Depth	Angle by Aircraft N = NAFEC U = Ohio Univ.	GSCM CDI
Hibbing	1/28	3"	2.43 N	100 μ a
	2/12	3"	2.42 U	110 μ a
	3/10	3"	2.58 N	80 μ a
International Falls	1/30	9"	3.49 N	154 μ a
	2/12	16"	3.29 U	130 μ a
	3/10	20"	3.35 N	155 μ a

Table 1. Compilation of GSCM, Flight and Snow Data.

Figures 18 through 29 give examples of GSCM CDI and snow depth versus time and these have been used to indicate the degree of correlation existing between these variables. The captions contain the explanations.

The data indicates that the GSCM is responding, on the average, in the proper manner to the increase in path angle due to snow. The question remaining is whether it can be made to provide a more precise prediction of the path angle so that it would be of more value to maintenance personnel. The following suggestions are offered.

1. The location of the monitor should be made on a basis supported by electromagnetic theory. At the low angles at which the GSCM is usually positioned, a large amount of ground contributes to the reflected signal (that is the Fresnel zones are quite long). The portion of the ground plane which causes the reflection for signal

received at a three degree angle is much smaller and nearer to the transmitting antennas. The GSCM might receive signals more representative of the far-field path signals if the GSCM were moved to within 1000 feet or so of the transmitting antennas. If the distance from the transmitting antennas cannot be changed, then the best receiving antenna height should be determined.

2. It would be very beneficial to send a control voltage from the transmitter to the GSCM to correct for any change in transmitter power. A power change cannot be distinguished from a snow depth change at the GSCM.

3. Direct measurement of the carrier amplitude might simplify this monitor scheme by eliminating some equipment requirements and the effects of DDM changes which seem to be almost random in nature (see Figure 16). Also, it would be easier to model, of course, if the carrier level were the only parameter affecting the output.

VIII. ACKNOWLEDGEMENTS

The contributions to this work range far beyond those of the authors. The Electrical Engineering team from Michigan Technological University consisted of Dr. Jon Soper, Dr. Ralph Horvath, and Dr. Dennis Wiitanen, plus some student support. These men, working against considerable odds, collected the bulk of the snow data for the season using their experimental site on Runway 25 at Houghton. A special team from NAFEC led by Bill Yost obtained important flight data using a DC-6 at Houghton, Hibbing and International Falls. The Airway Facilities Sector field office personnel at Minneapolis, Hibbing, International Falls and Houghton were extremely important, too, in providing assistance in the data collection. This was done in addition to their regular duties at the sites. Finally the operating staff of the Houghton County Airport, headed by Mr. Bud Hagman, and the Airport Commission, chaired by Richard Dunnebacke, deserve a vote of thanks for making the experimental snow site facilities available.

INL

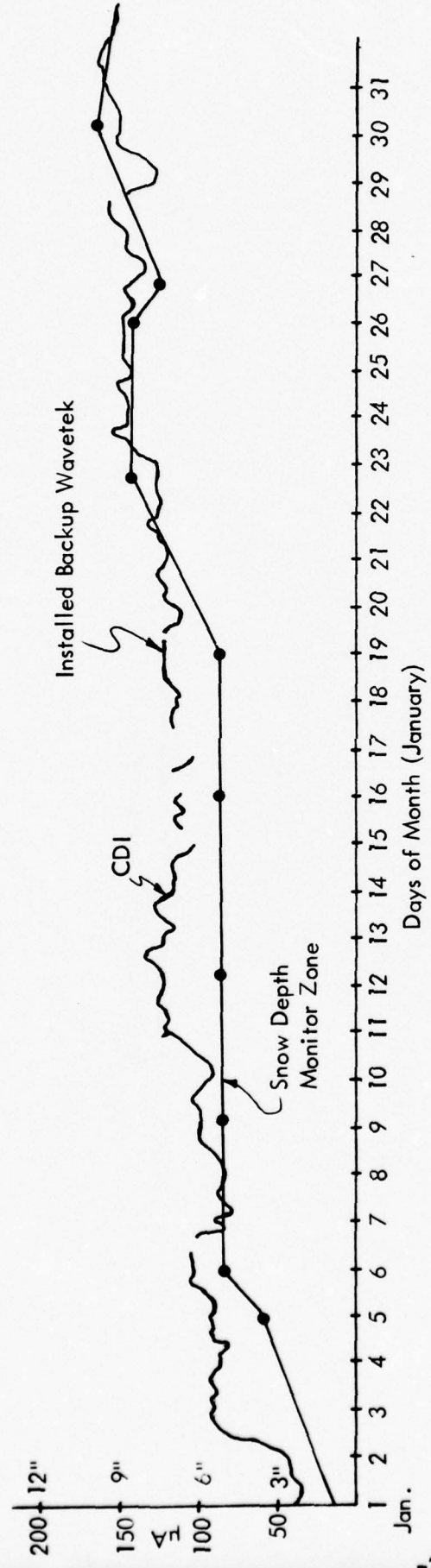

Figure 18. Initial Data from International Falls with Snow Depth Values Available Being Those for the Monitor Zone. After plowing the monitor area, the depth of the snow there gradually assumes the depth of the surrounding layer. Realizing this, one observes a reasonably good correlation of the GSCM CDI with measured snow depth. The International Falls facility had only the monitor area plowed in the winter, never the complete trapezoid. Of course any increases of snow depth recorded in the monitor can be considered for the total reflecting zone.

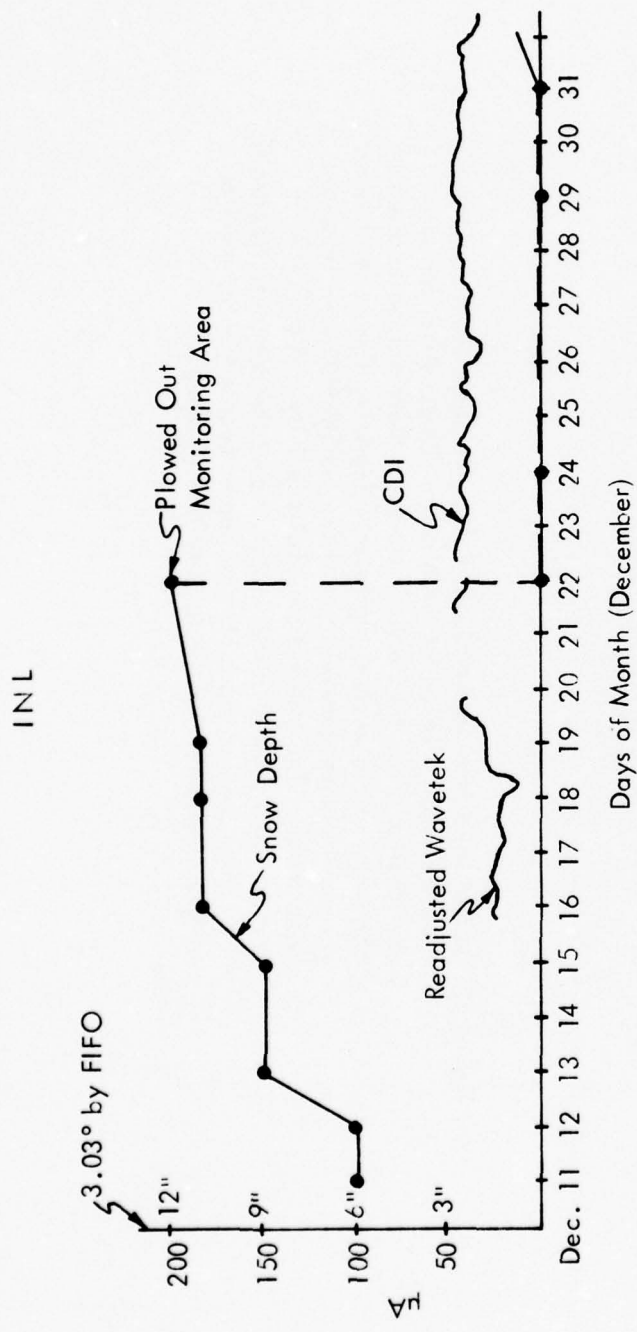

Figure 19. A Continuation of the International Falls Data Showing Reasonable Positive Correlation.

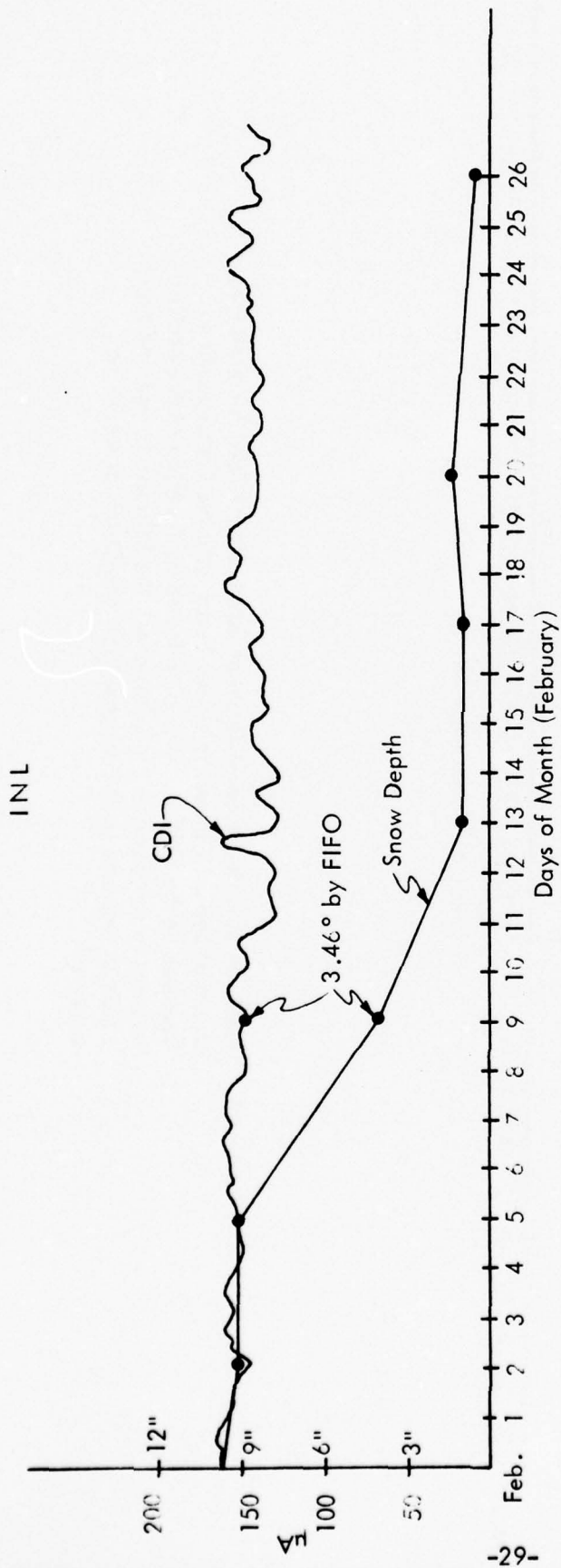

Figure 20. Additional Data from International Falls Revealing Greater Day-To-Day Variation in GSCM CDI Than Observed for a Change in Snow Level. This type of data identifies the need for a monitor or control on the transmitted power level.

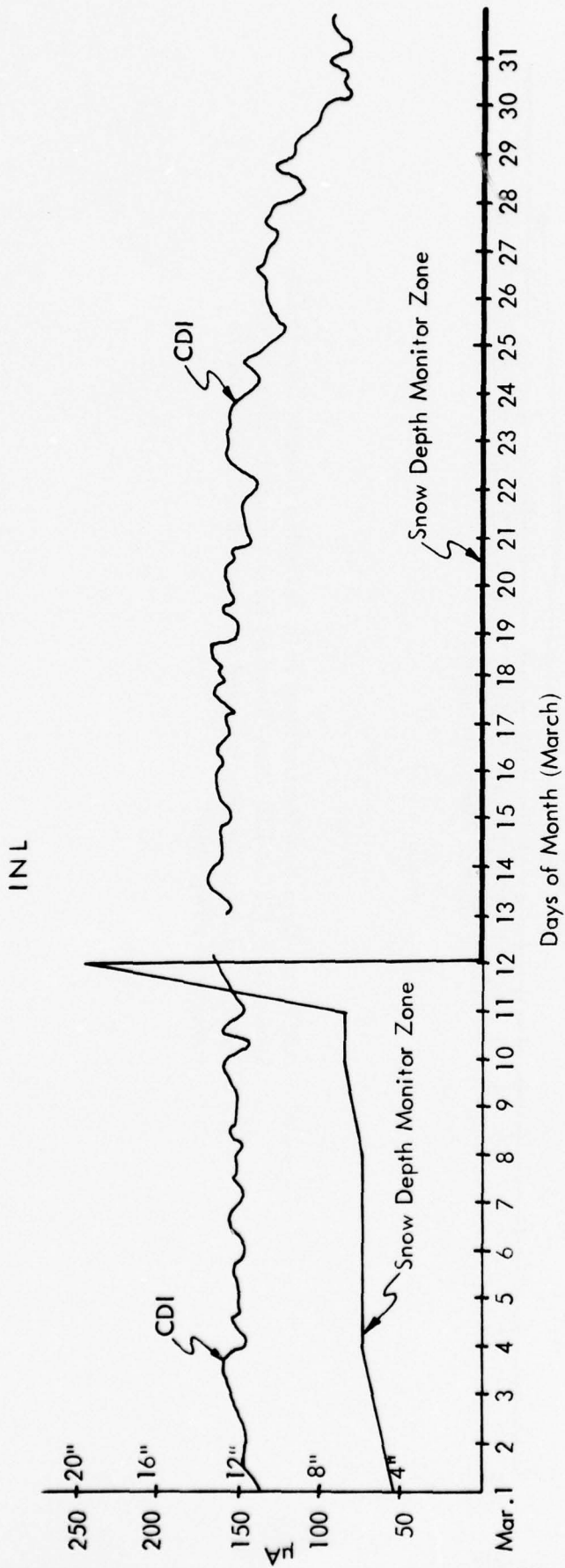

Figure 21. Example of a Heavy Snow Storm at International Falls Increasing the Depth of Snow 13 Inches in a Few Hours with No Corresponding Response of the GSCM. This is followed by a period with essentially no snow in the monitor zone; however, the following graph indicates a GSCM response to the general snow conditions as would be expected.

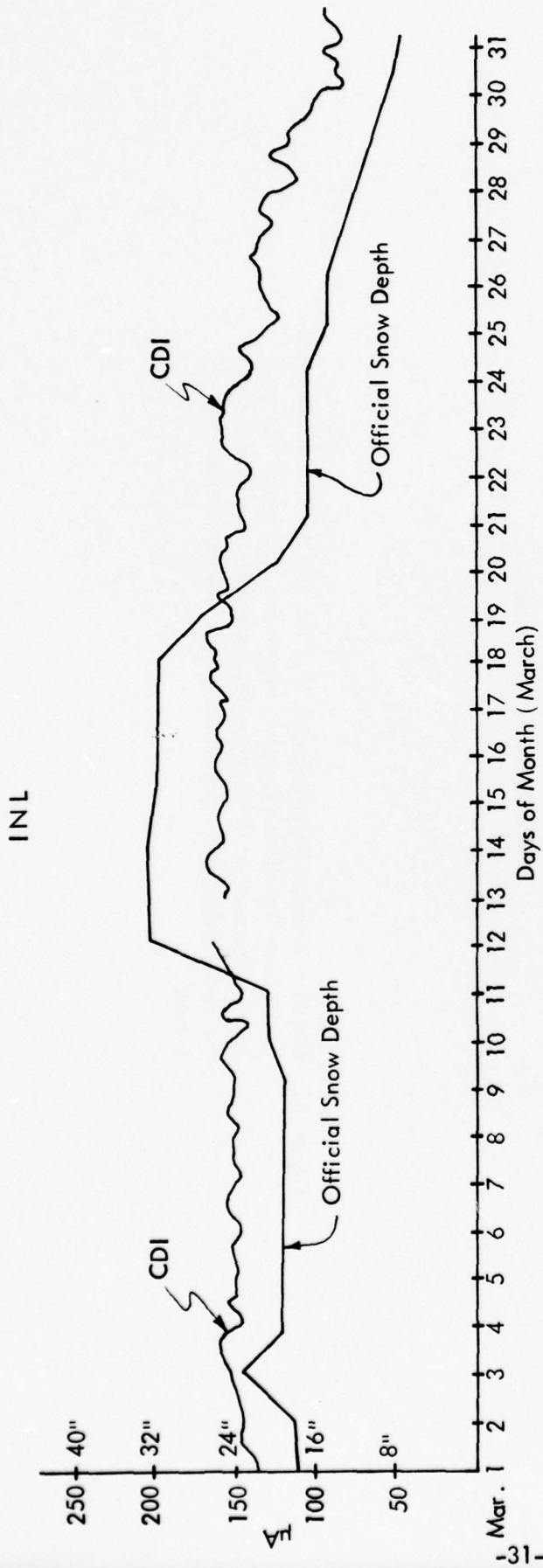

Figure 22. Considering the Same Time Period Shown in Figure 21, One Finds a Better Correlation Between the GSCM and the Official Snow Depth. As would be expected, the GSCM is responding to snow depths outside the nominal reflection zone for the monitor.

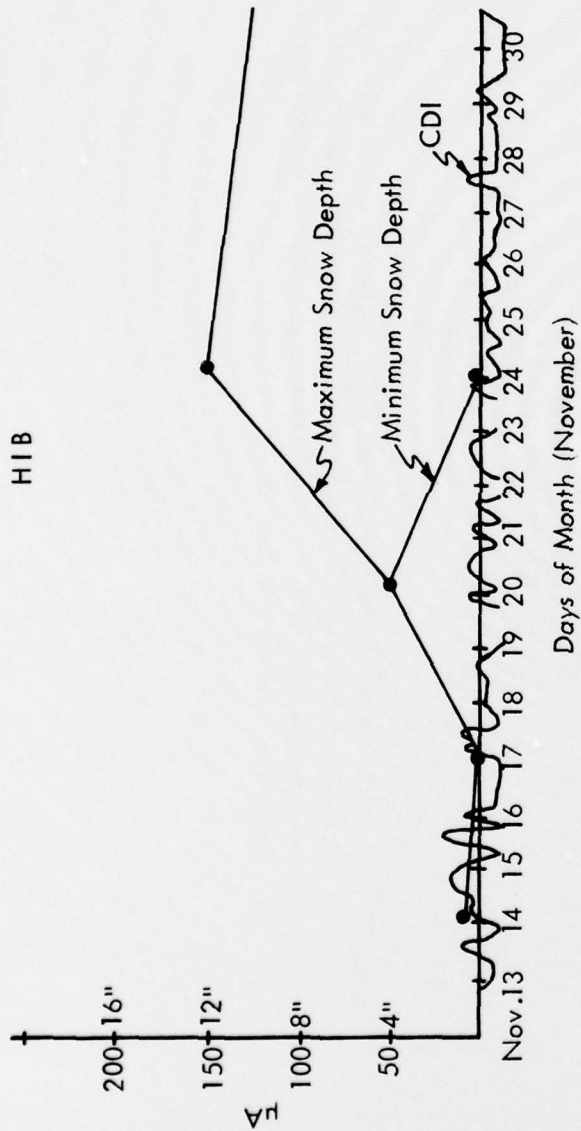

Figure 23. The First Hibbing Data Indicates That the GSCM Did Not Respond to the First Significant Snows in November. Although the snow depths recorded for Hibbing are for the monitor reflecting area, the depth values are representative until the monitor area is plowed.

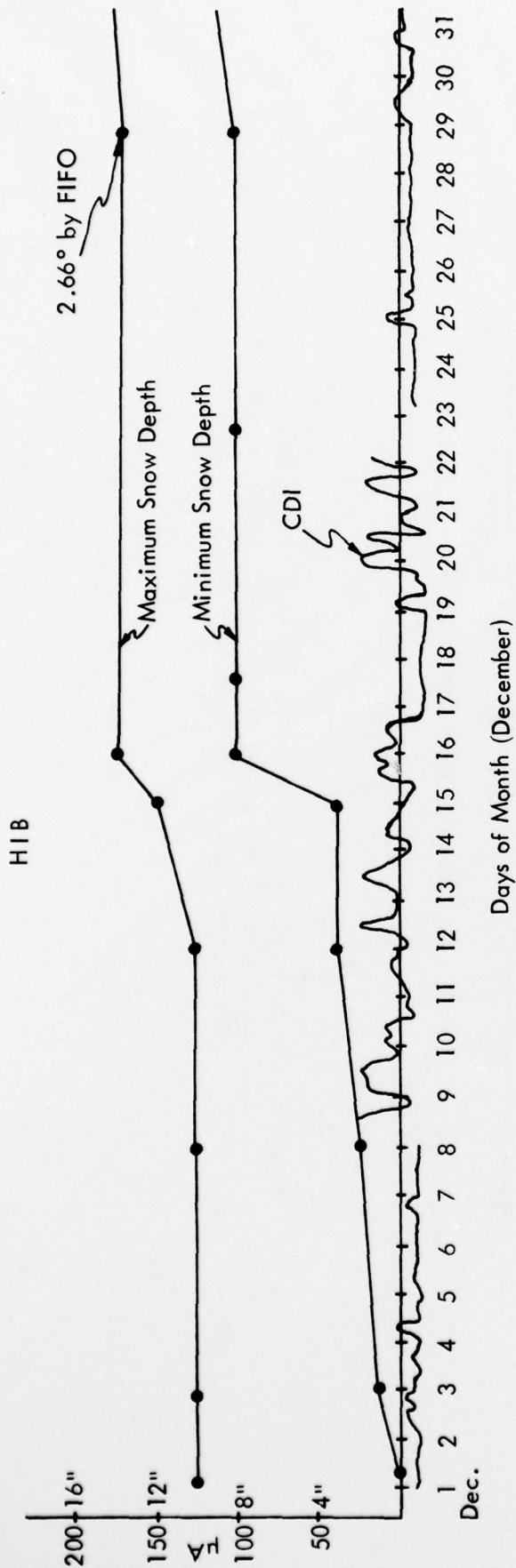

Figure 24. Again, the Mid-December Snowfall Did Not Produce a Significant Indication on the GSCM. Day-to-day variations are seen to be the predominant feature of the GSCM record.

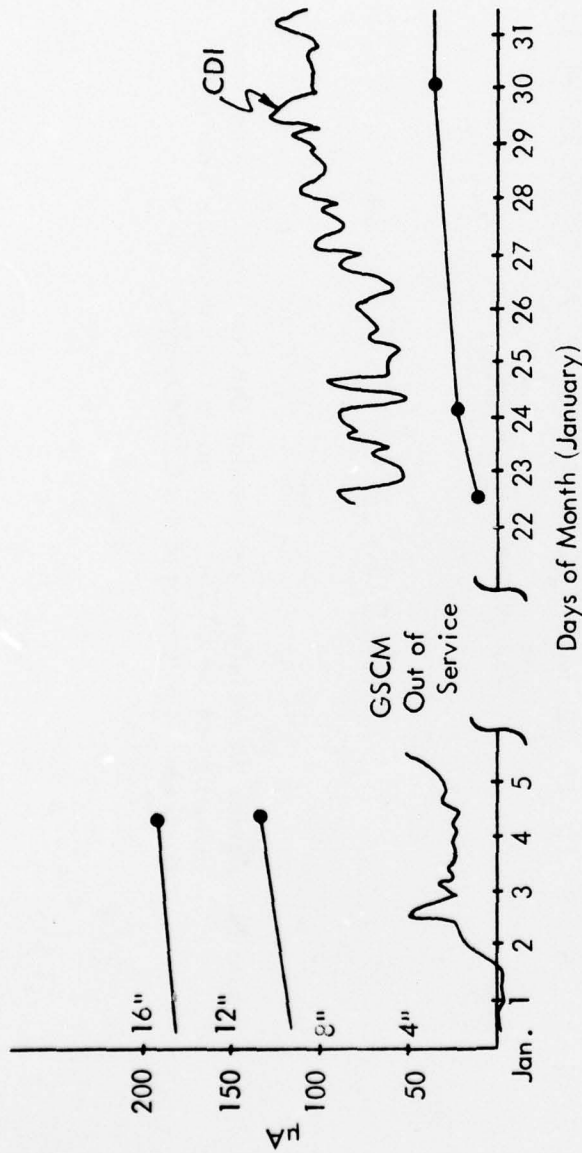

Figure 25. In January an Interruption of the GSCM at Hibbing Causing a Loss of Data. However, a positive correlation became apparent as snow depth increased late in the month.

HIB

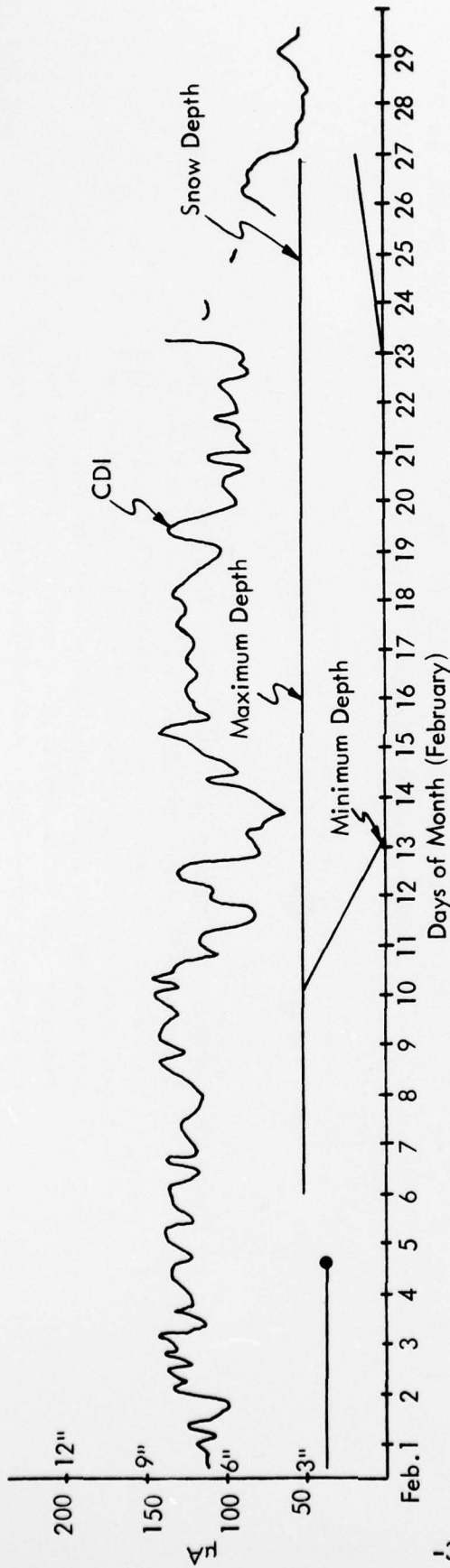

Figure 26. Data from Hibbing Showing the Rather Large Day-To-Day Variations in GSCM Output in Spite of Reasonably Constant Reported Snow Depths. Again, recording other parameters such as transmitter power, building temperature, and some voltage levels would be necessary to positively identify the cause of the variations.

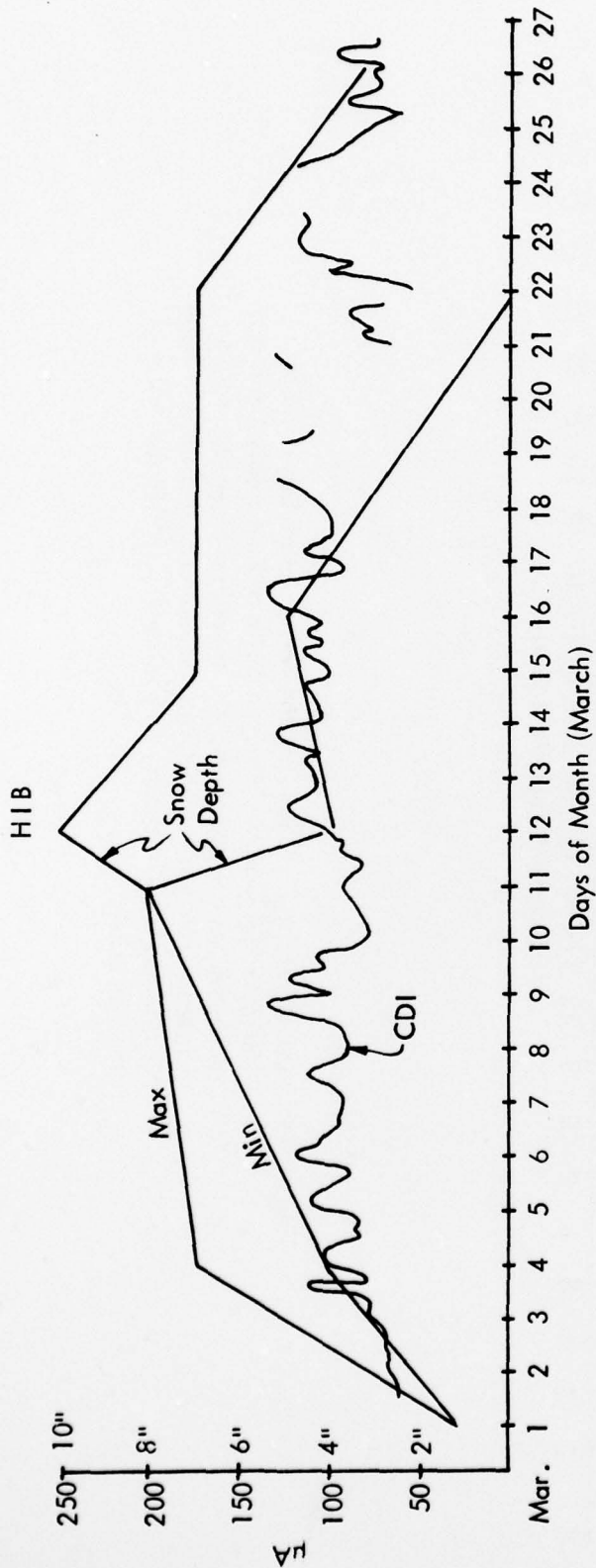

Figure 27. Comparison of Hibbing with INL for Same Time Period Showing Greater Day-To-Day Variation of GSCM. Not all of this can be attributed to a variation of the transmitter carrier power which was documented as ranging from 2.95 to 3.10 watts. Maximum and minimum snow depths in the monitor reflection area are indicated. Correlation appears low even when considering only the increasing snow periods. A defective transmitter power supply which affected carrier power output was replaced in February. Unfortunately, no improvement was obtained in GSCM stability

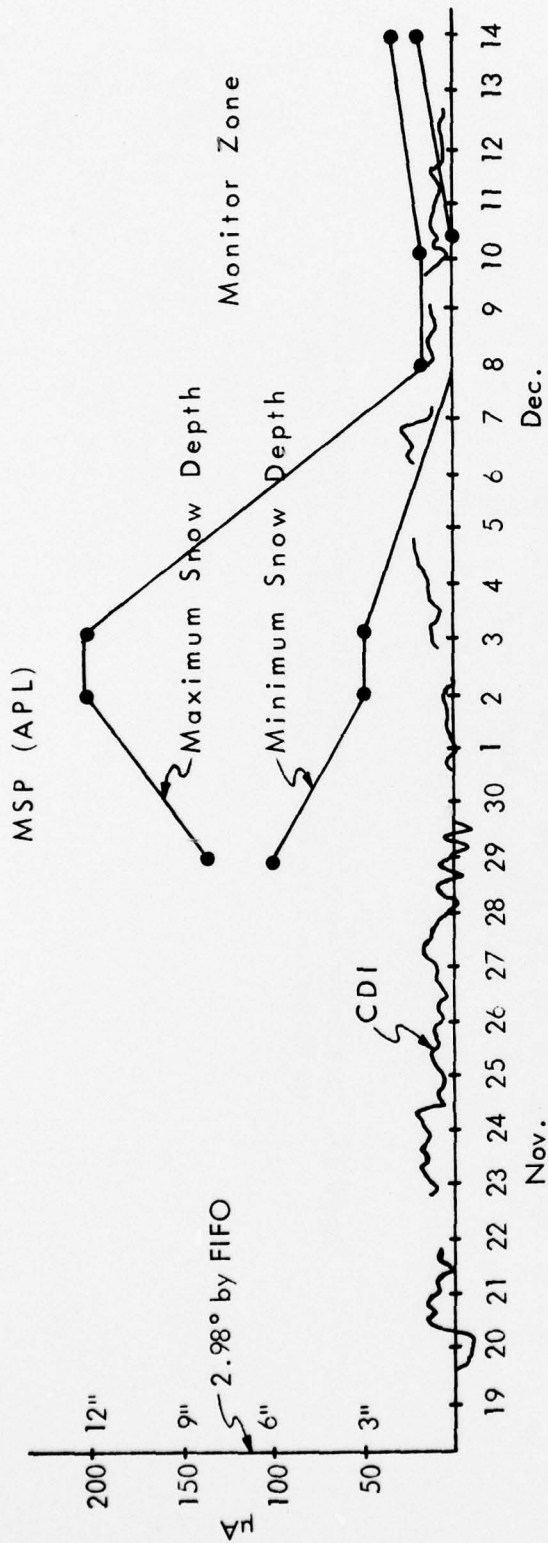

Figure 28. GSCM CDI Indication at Minneapolis Runway 4 During a Period of Increasing and Decreasing Snow Depths. These snow depths are for the monitor reflection zone. Correlation is found to be low considering just the increasing snow conditions. Data from Minneapolis was sporadic because of the Runway 4 ILS interlock with Runway 22 ILS.

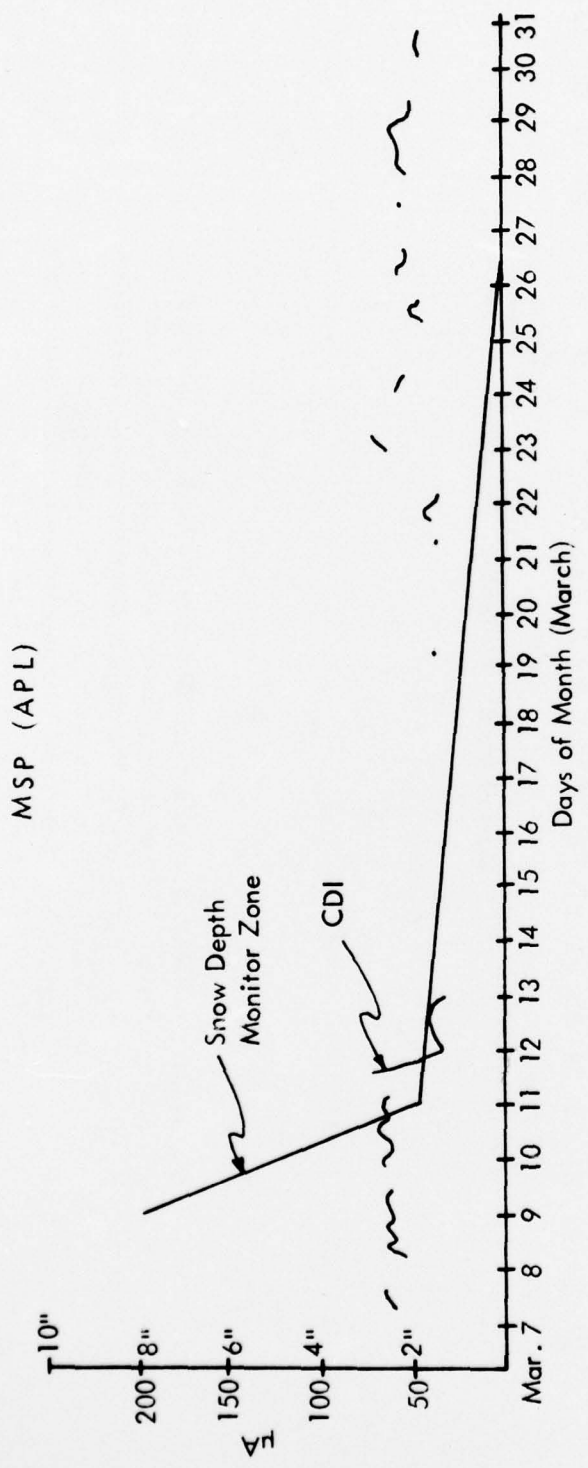

Figure 29. Late Season Data for Minneapolis Showing Change in Snow Depth for Reflection Zone But No Corresponding Change in GSCM.

IX. APPENDICES

A. RF Signal Strength and DDM Meter.

It is difficult to make precise RF signal strength measurements over a very wide dynamic range using a receiver's automatic gain control (AGC) voltage. The AGC voltage is typically a very nonlinear function of RF amplitude and it may depend strongly on other factors such as power supply voltage and temperature. Using very low-cost components, an intermediate frequency may be generated which is directly proportional to RF signal amplitude and is very easily measured with inexpensive audio frequency linear integrated circuits. Precise measurements can be made down to about 300 microvolts at which point the noise present with the signal begins to cause an error. The upper limit is 1000 microvolts but, with attenuators at the input, virtually any signal level above 1000 microvolts can be measured. Because the 90/150 Hz composite signal is present at the detected IF, it is possible to apply the composite signal to an audio processing circuit to extract the DDM information. This audio processing circuit has been in use in the Mini-Lab in airborne data collection. This circuit allows more precise DDM measurements to be taken at high DDM levels than many conventional receiver circuits which are designed to be used in the $\pm .175$ DDM range.

Figure A-1 shows the basic part of signal strength measuring circuit. A double balanced modulator is driven at +7 dBm at a frequency 14 KHz above the glide-slope channel frequency at its L.O. port by a Wavetek Model 3000 signal generator. The unknown signal source (the antenna cable in this case) is connected to the RF port. An IF frequency of about 14 KHz whose amplitude is directly proportional to the RF input level, is produced at the IF output of the modulator. The choke and capacitor form a low-pass filter which attenuates any RF components at the output and passes only the IF to the LM 382 low noise operational amplifier. The IF is amplified about 40 dB by this amplifier and is passed to an AD 518 operational amplifier wired in a precision half-wave rectifier configuration. The half-wave rectified IF is passed to a 741 operational amplifier wired as a low-pass filter with a corner frequency of about 4 Hz. This results in a DC level proportional to the input RF level appearing at the output of the 741. All audio components are attenuated to very low levels. The DC level may be read on the meter movement or may be monitored more precisely by connecting a digital voltmeter to the "DC out" port. A DC level of 1.00 volt at the "DC out" port is equivalent to 1000 microvolts at the RF input. This is a full scale reading and higher RF levels can be read by inserting a pad in the RF line and insuring that the RF level is below 1000 microvolts at the RF input.

The half-wave rectified IF is also applied to an AD 533 multiplier/divider wired as an analog divider. The rectified IF is the numerator and the DC proportional to the RF level is the denominator. This produces an output at the AD 533 which is nearly independent of RF level. The rectified IF envelope at the AD 533 output carries the 90/150 Hz composite audio and is applied to the DDM processing circuitry.

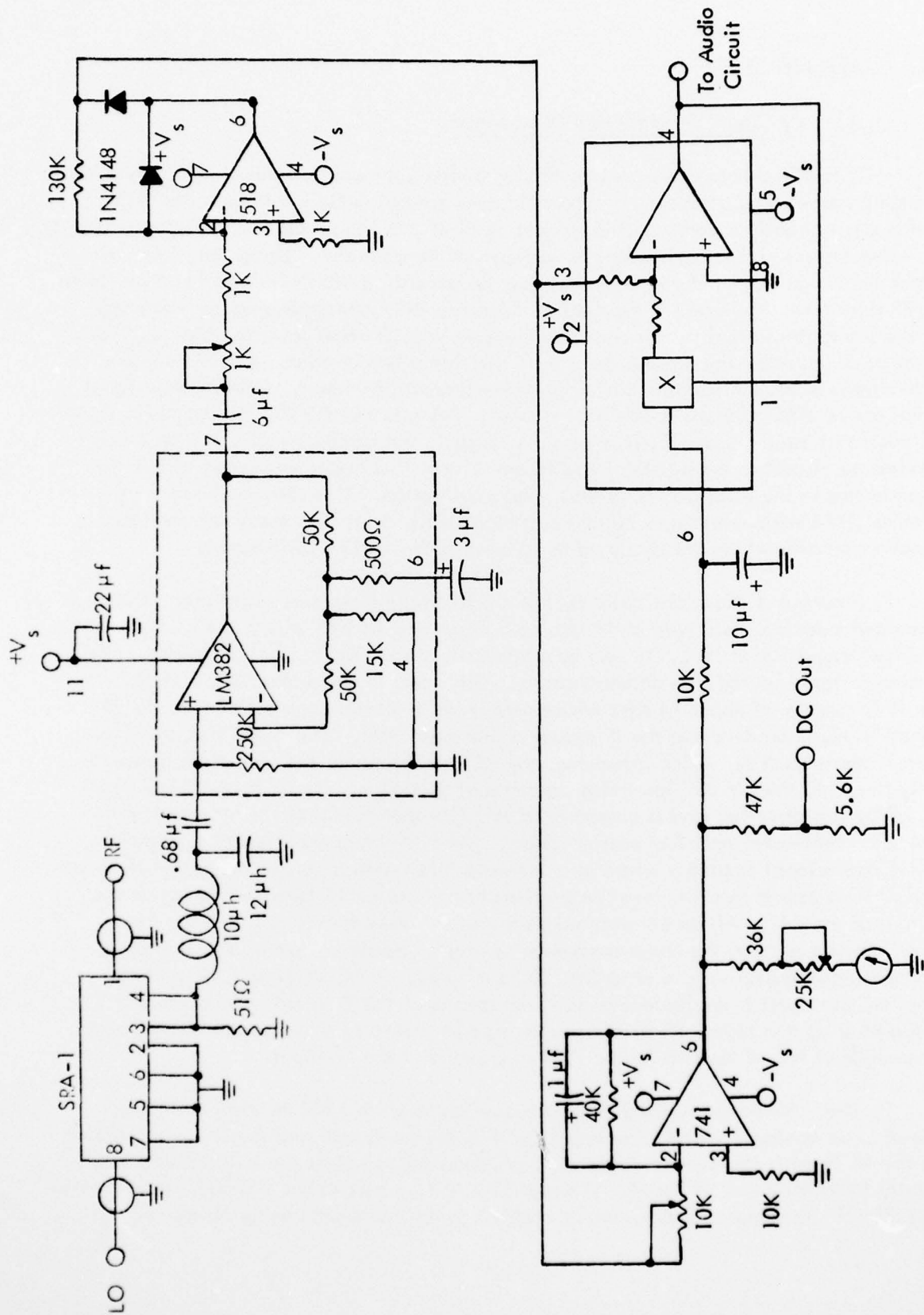
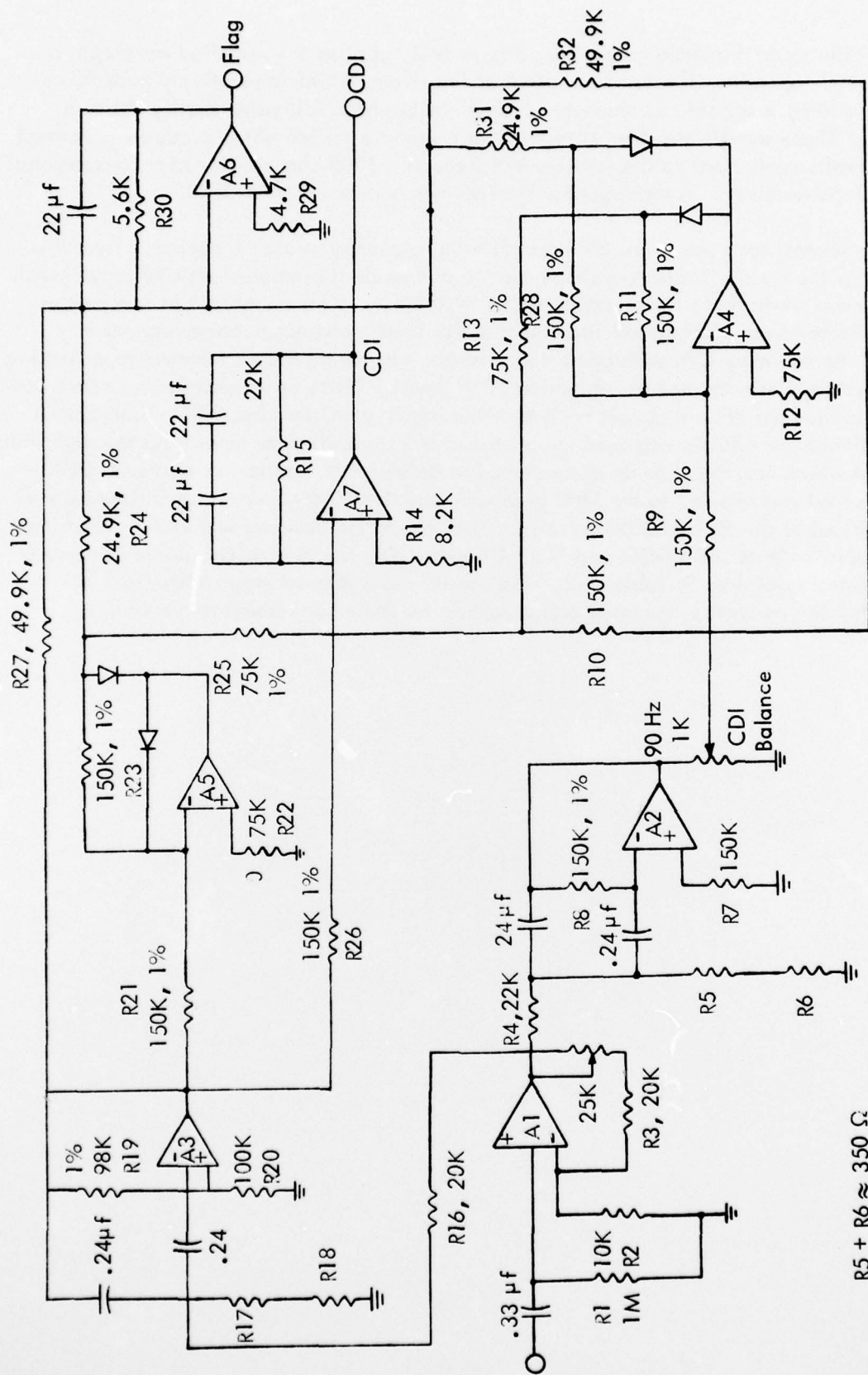

Figure A-1. RF Measuring Circuit.

The DDM processing circuitry, Figure A-2, applies the rectified envelope to 90 and 150 Hz active filters. The output of the filter, which is relatively pure 90 and 150 Hz audio, is applied to absolute value circuits which full wave rectify the two signals. These signals are then subtracted in a low-pass filter which produces a voltage in millivolts equivalent to the CDI current through a 1000 ohm resistor in a conventional glide-slope receiver. A reading of 150 millivolts represents .175 DDM.

Several tests were run to determine what accuracy could be expected from this device in the field. Table A-1 shows the DC out reading compared with RF input levels set by Hewlett-Packard Model 8405 Vector Voltmeter. Agreement within two percent is maintained from 1000 to 400 microvolts while lower readings become increasingly worse. An arbitrary CDI voltage of 73 millivolts was set on the CDI output to determine how much it would change as a function of RF level. Little or no change was noted down to 300 microvolts RF. A circuit built by Ohio which provides high DDM value with a predominance of 150 Hz was used to test the unit's capability for measuring the high values of DDM which are likely to be encountered in below-path monitoring work. A DDM value as indicated was applied to the UHF generator and the 1000 microvolt modulated signal was applied to the RF level/DDM meter. The proper CDI reading was calculated from the equivalence of .175 DDM and 150 millivolts CDI, and the calculated and measured values were compared in Table A-2. The results were deemed very satisfactory in providing the necessary accuracy and precision for the measurement at Houghton.



R5 + R6 ≈ 350 Ω
 R17 + R18 ≈ 180 Ω

Figure A-2. Precision Audio Processing Circuit.

RF Input (microvolts)	DC Output (volts)	CDI Output (millivolts)
1000	1.00	73
900	.896	73
800	.800	73
700	.696	73
600	.600	73
500	.505	73
400	.409	73
300	.312	73
200	.216	70
100	.125	51

Table A-1. RF Input Vs. DC Output.

DDM	Calculated CDI (millivolts)	Measured CDI (millivolts)
.300	257	259
.320	274	275
.340	291	292
.360	309	310
.380	326	328
.400	343	345
.420	360	363
.440	377	381
.460	394	398
.480	411	415
.500	429	432

Table A-2. Measured CDI Vs. Calculated CDI.

B. Houghton Runway 25 Cross Section from Glide-Slope Mast to GSCM.

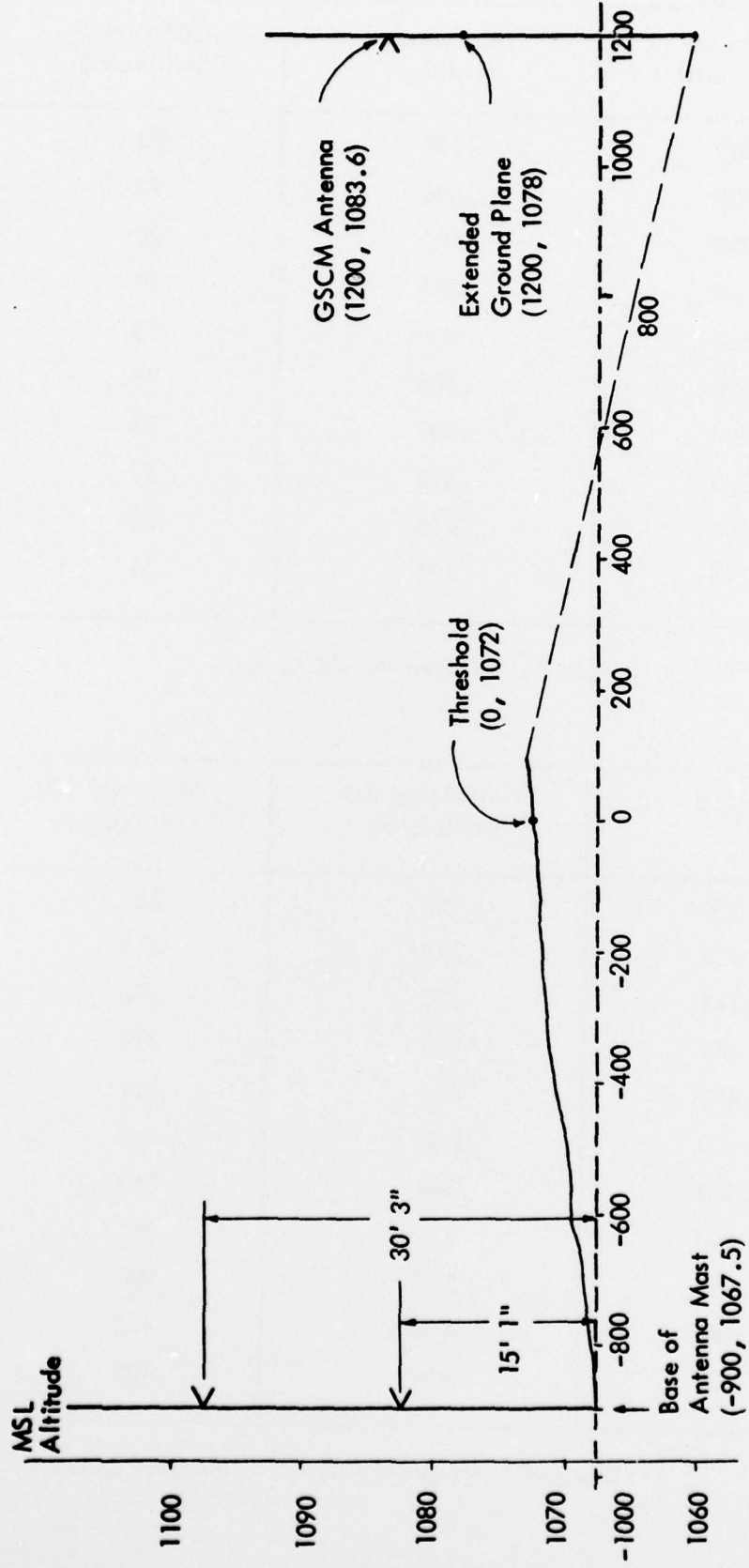

C. Path Angles Reported by Minneapolis Flight Inspection.

Winter 1975-76

APL 11/14 $\theta = 2.98^\circ$ - Periodic

↓ No Reports Until

3/3 $\theta = 3.08^\circ$ - Periodic

4/30 $\theta = 3.13^\circ$ - Periodic

6/23 $\theta = 3.03^\circ$ - Periodic

HIB 12/29 $\theta = 2.66^\circ$ - Periodic (Commissioned Path Angle 2.50°)

4/19 $\theta = 2.62^\circ$ - Periodic

INL 12/9 $\theta = 3.03^\circ$ - Periodic

2/9 $\theta = 3.46^\circ$ - Special Request Ohio University

4/7 $\theta = 3.01^\circ$ - Periodic
