

AD-A041 188

CONSTRUCTION ENGINEERING RESEARCH LAB (ARMY) CHAMPAI--ETC F/G 5/5
DEVELOPMENT OF AN OBJECTIVE DEFINITION OF HABITABILITY AND A HA--ETC(U)
JUN 77 R L BRAUER, T A DAVIS

UNCLASSIFIED

CERL-SR-D-79

NL

4 OF 12
AD
A041188

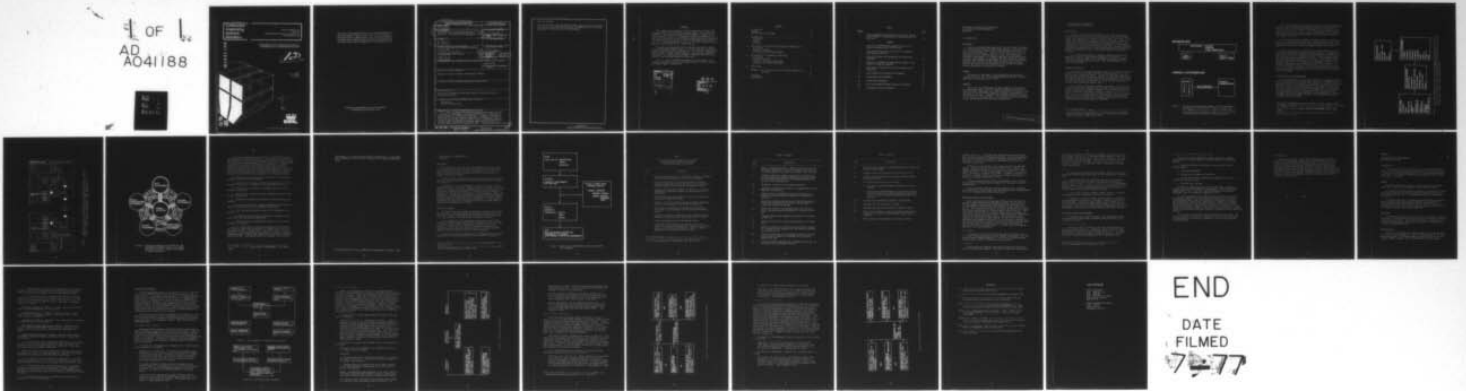

construction
engineering
research
laboratory

SPECIAL REPORT D-79
June 1977
Identification and Classification of Human Needs
in the Military Facility

DEVELOPMENT OF AN OBJECTIVE DEFINITION OF
HABITABILITY AND A HABITABILITY DATA BASE

ADA 041 188

12

by
R. L. Brauer
T. A. Davis

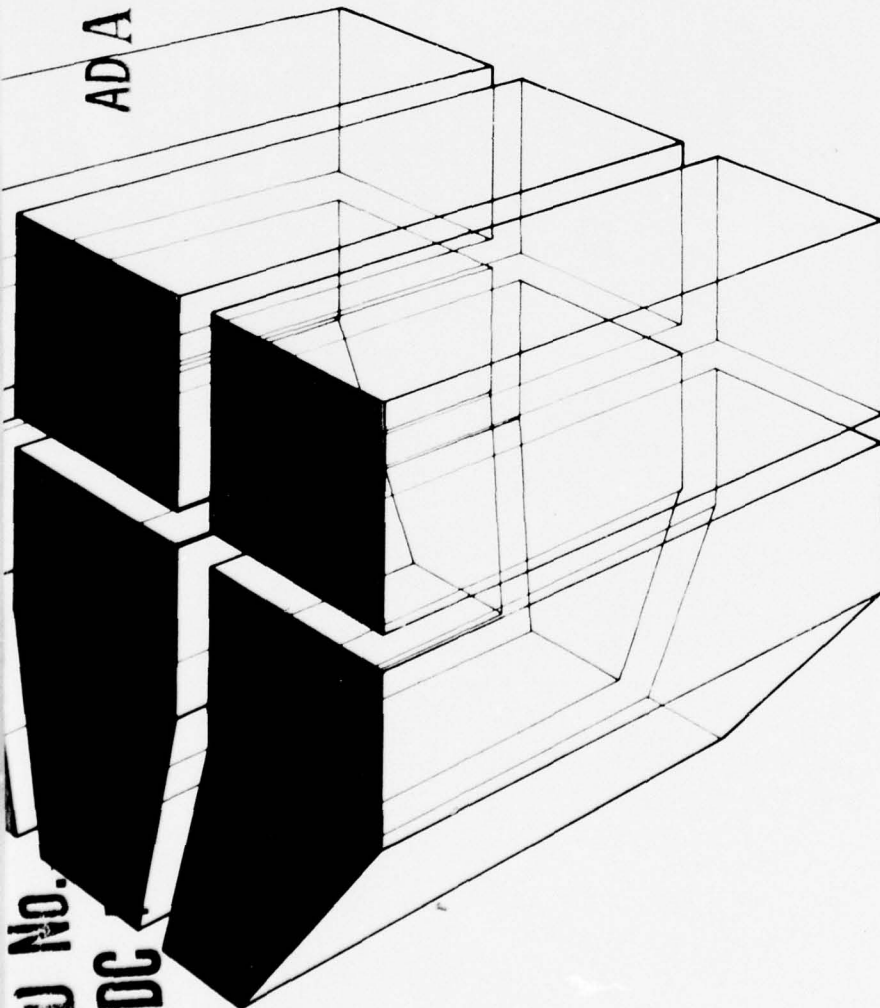

AJ No.
DDC

DDC
RESEARCH
JUL 5 1977
D



The contents of this report are not to be used for advertising, publication, or promotional purposes. Citation of trade names does not constitute an official indorsement or approval of the use of such commercial products. The findings of this report are not to be construed as an official Department of the Army position, unless so designated by other authorized documents.

***DESTROY THIS REPORT WHEN IT IS NO LONGER NEEDED
DO NOT RETURN IT TO THE ORIGINATOR***

UNCLASSIFIED

SECURITY CLASSIFICATION OF THIS PAGE (When Data Entered)

REPORT DOCUMENTATION PAGE		READ INSTRUCTIONS BEFORE COMPLETING FORM
1. REPORT NUMBER 14 CERL-SR-D-79	2. GOVT ACCESSION NO.	3. RECIPIENT'S CATALOG NUMBER
4. TITLE (and Subtitle) 6 DEVELOPMENT OF AN OBJECTIVE DEFINITION OF HABITABILITY AND A HABITABILITY DATA BASE • 9	5. TYPE OF REPORT & PERIOD COVERED FINAL / rept.	
7. AUTHOR(s) 10 R. L. Brauer toget I. A. Davis Thomas	6. PERFORMING ORG. REPORT NUMBER	
9. PERFORMING ORGANIZATION NAME AND ADDRESS CONSTRUCTION ENGINEERING RESEARCH LABORATORY P.O. Box 4005 Champaign, Illinois 61820	8. CONTRACT OR GRANT NUMBER(s)	
11. CONTROLLING OFFICE NAME AND ADDRESS 12 35p.	10. PROGRAM ELEMENT, PROJECT, TASK AREA & WORK UNIT NUMBERS 16 4A762719AT03-01-001	12. REPORT DATE 11 Jun 1977 17 91
14. MONITORING AGENCY NAME & ADDRESS (if different from Controlling Office)	13. NUMBER OF PAGES 35	15. SECURITY CLASS. (of this report) UNCLASSIFIED
15a. DECLASSIFICATION/DOWNGRADING SCHEDULE		
16. DISTRIBUTION STATEMENT (of this Report) Approved for public release; distribution unlimited.		
17. DISTRIBUTION STATEMENT (of the abstract entered in Block 20, if different from Report)		
18. SUPPLEMENTARY NOTES Copies are obtainable from National Technical Information Service, Springfield, VA 22151		
19. KEY WORDS (Continue on reverse side if necessary and identify by block number) habitability habitability data base		
20. ABSTRACT (Continue on reverse side if necessary and identify by block number) This report summarizes the work performed through fiscal year 1975 in two areas: development of an objective definition of habitability and development of a habitability data base. Although it has been assumed that an absolute, objective definition of habitability cannot be reached because of the subject's dynamic nature, considerable progress has been made in developing a definition which provides a means for dealing systematically with habitability data. The prototype Habitability → not per.		

405 249

Block 20 (cont'd)

→ Data Base which has been developed provides a way of collecting, analyzing, storing, and retrieving such data. Recommendations for continuing development in both areas are also presented. ←

UNCLASSIFIED

SECURITY CLASSIFICATION OF THIS PAGE(When Data Entered)

FOREWORD

This research was conducted for the Directorate of Military Construction, Office of the Chief of Engineers (OCE), under Project 4A7-62719AT03, "Architectural Research and Development in Support of Military Facilities"; Task 01, "Architectural Criteria for Planning and Design of Military Facilities for Meeting Human Requirements"; Work Unit 001, "Identification and Classification of Human Needs in the Military Facility." The applicable QCR is 1.01.012. The OCE Technical Monitors were Mr. Richard Cramer and Mr. Robert Shibley.

The work was performed by the Architecture Branch (HPA), Habitability and Planning Division (HP), U.S. Army Construction Engineering Research Laboratory (CERL), Champaign, IL. The principal investigator was Dr. Roger L. Brauer, and Mr. Thomas A. Davis was the associate investigator. Dr. Charles Lozar assisted in completing the field evaluation of the prototype Habitability Data Base.

COL J. E. Hays is Commander and Director of CERL and Dr. L. R. Shaffer is Technical Director. Mr. Robert Porter is Chief of HPA and Dr. Robert Dinnat is Chief of HP.

ACCESSION for	
NTIS	White Section <input checked="" type="checkbox"/>
DDC	Buff Section <input type="checkbox"/>
UNANNOUNCED	<input type="checkbox"/>
JUSTIFICATION	
BY	
DISTRIBUTION/AVAILABILITY CODES	
Dist. AVAIL. and/or SPECIAL	
A	

DDC
RECEIVED
JUL 5 1977
REGISTRATION
D

CONTENTS

	DD FORM 1473	1
	FOREWORD	3
	LIST OF TABLES AND FIGURES	5
1	INTRODUCTION	7
	Background	
	Purpose	
	Approach	
2	DEVELOPMENT OF AN OBJECTIVE DEFINITION OF HABITABILITY . . .	8
	Description	
	Summary of Progress	
	Directions for Future Development	
3	DEVELOPMENT OF A HABITABILITY DATA BASE.	16
	Description	
	Summary of Progress	
	Summary of Results of Field Input	
	Directions for Future Development	
4	CONCLUSIONS.	24
	APPENDIX: An Introduction to the Prototype Habitability	
	Data Base	25
	REFERENCES	35
	DISTRIBUTION	

TABLES

<u>Number</u>		<u>Page</u>
1	Tasks Completed by the University of Illinois Library Research Center in Developing a Prototype Habitability Data Base	18

FIGURES

1	Structure of Relationships Between Activities and Physical Characteristics of Facilities	9
2	Early Data Categories for Facilities, Environments, Relationships, and Users	11
3	Detailed Structure for Habitability and Contextual Properties	12
4	Structural Framework for Habitability Viewed in the Context of Other Environments	13
5	Major Steps in Habitability Criteria Generation and Validation	17
A1	Data Categories of Habitability Statements	28
A2	Relationship Data Statements	28
A3	Context Data Statements	30
A4	Human Requirement and Report Objective Statements	32
A5	Performance Criteria Statements	34

DEVELOPMENT OF AN OBJECTIVE DEFINITION
OF HABITABILITY AND A HABITABILITY
DATA BASE

1 INTRODUCTION

Background

Quality Construction Requirement (QCR) 1.01.012, dated 19 November 1974, addresses the problem of developing procedures to generate, evaluate, and communicate criteria which relate personnel requirements to architectural requirements. In part, this QCR specifically calls for procedures which (1) identify physical, social, and psychological (personnel) requirements, (2) identify functional and technical (architectural) requirements, (3) accurately define relationships between personnel and architectural requirements so that criteria can be developed from them, and (4) provide a means for collecting, analyzing, storing, and retrieving such relationship data in order to support criteria development and habitability research.

Purpose

The purpose of this report is to document the work performed through fiscal year 1975 (FY 75) toward developing the four procedures identified as necessary in QCR 1.01.012.

Approach

Work on the four requirements has been conducted in two separate but interrelated parts. The first three requirements have been addressed through development of an objective definition of habitability, while work on the fourth requirement has centered on development of a habitability data base. Chapters 2 and 3 summarize the work completed to date and plans for future work on the objective definition of habitability and the habitability data base, respectively.

PRECEDING PAGE BLANK-NOT FILMED

2 DEVELOPMENT OF AN OBJECTIVE DEFINITION OF HABITABILITY

Description

An objective definition of habitability is a formalized concept that is the basis for describing in quantitative terms how individuals, groups, and organizations respond or relate to built facilities. To be useful, the concept must be formalized to the extent that components, factors, or variables are identified, logically grouped together, and interrelated. An objective definition of habitability is necessary to systematically classify and store habitability data, generate meaningful habitability requirements and criteria, develop practical procedures for applying habitability criteria, and conduct pragmatic habitability research.

It is questionable whether an absolute, objective definition of habitability can be reached because habitability is dynamic. It is subject to changing values and is confounded by nebulous, conceptual terms whose meanings change over time. Also, new knowledge is continually being added.

Summary of Progress

Little prior work aimed at deriving a practical scheme for relating people to facilities has been reported in the literature; thus, this work has been a pioneering effort. Despite the limitations described in the previous section, considerable progress has been made in developing an objective definition of habitability and in achieving a useful structure for identifying characteristics of people and facilities and expressing the relationships between them.

The structure and elements previously documented¹ relate activities (defined as observable behaviors and attitudes) to physical characteristics of facilities, as shown in Figure 1. To provide necessary background information, additional categories called *user group*, *facility*, and *facility area* (function area or space) as well as physical, management, and financial constraints were included with activity-physical characteristic relationship data. However, detailed lists of classifications within categories were not developed.

¹D. L. Dressel and R. L. Brauer, *Initial Report on Systemizing Information to Identify and Relate Behavior and Physical Design Parameters*, Preliminary Report D-4/AD757627 (U.S. Army Construction Engineering Research Laboratory [CERL], March 1973).

BACKGROUND DATA

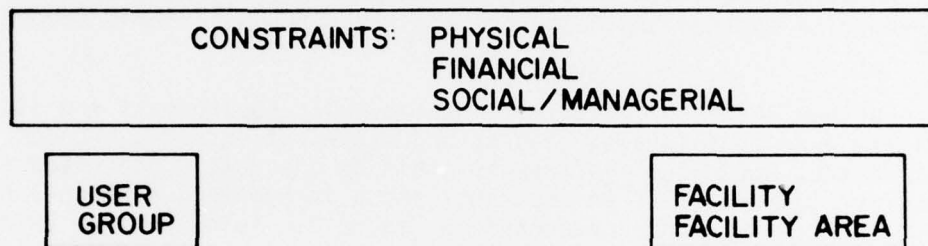

HABITABILITY RELATIONSHIP DATA

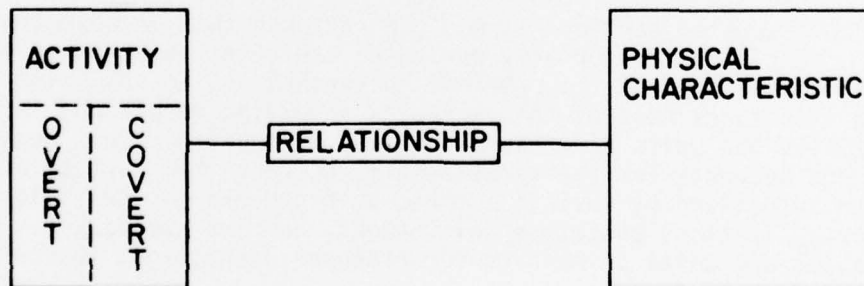

Figure 1. Structure of relationships between activities and physical characteristics of facilities. From D. L. Dressel and R. L. Brauer, *Initial Report on Systemizing Information to Identify and Relate Behavior and Physical Design Parameters*, Preliminary Report D-4/AD757627 (CERL, March 1973).

Davis² began developing the detailed classifications by structuring a generic classification and coding scheme based on terminology found in Army and other literature being reviewed for input to the prototype Habitability Data Base. Figure 2 is a schematic representation showing classifications for type of user, type of environment, type of relationship between the user and the environment, and background information about type of facility.

As more literature was reviewed, some modifications to the structure and classifications were required. These changes resulted in the updated structure shown in Figure 3 and presented by Davis in U.S. Army Construction Engineering Research Laboratory (CERL) Interim Report D-68.³

Further research led to viewing the built environment and its relationship to individuals, groups, and organizations in a broader context so that contextual influences could be adequately accounted for, as shown in Figure 4. The environments shown in Figure 4 contain many of the structural elements presented in Figure 1. Relationships between the built environment and people are not viewed as directional; thus, the built environment is not seen only as a dependent variable. This diagram is now being used to develop detailed lists of variables, dimensions, and units of measure within the built environment. Next, lists of variables, dimensions, and units of measure will be developed for the physiological-psychological environment and the social-organizational environment.

Directions for Future Development

As discussed earlier, it has been assumed that an objective definition of habitability for Army personnel can never be achieved because of the dynamic nature of the problem. Nevertheless, an objective definition which structures most of the variables involving people and facilities, identifies the units of measure for each, groups them in a meaningful way, and accounts for the relationships between them must be achieved. As conceptualized by Davis,⁴ a three-step process can be employed: conceptualization, prototype development, and implementation. Once the variables and units of measure for each are identified, the conceptualization phase is complete.

²T. A. Davis, "Systematizing Man-Environment: Toward a Model of Man-Environment Relations," *Man-Environment Systems*, Vol 4 (1974), pp 181-184.

³T. A. Davis, *Conceptualization of Habitability Expressions for the Habitability Data Base*, Interim Report D-68/ADA029661 (CERL, August 1976).

⁴T. A. Davis, *Conceptualization of Habitability Expressions for the Habitability Data Base*.

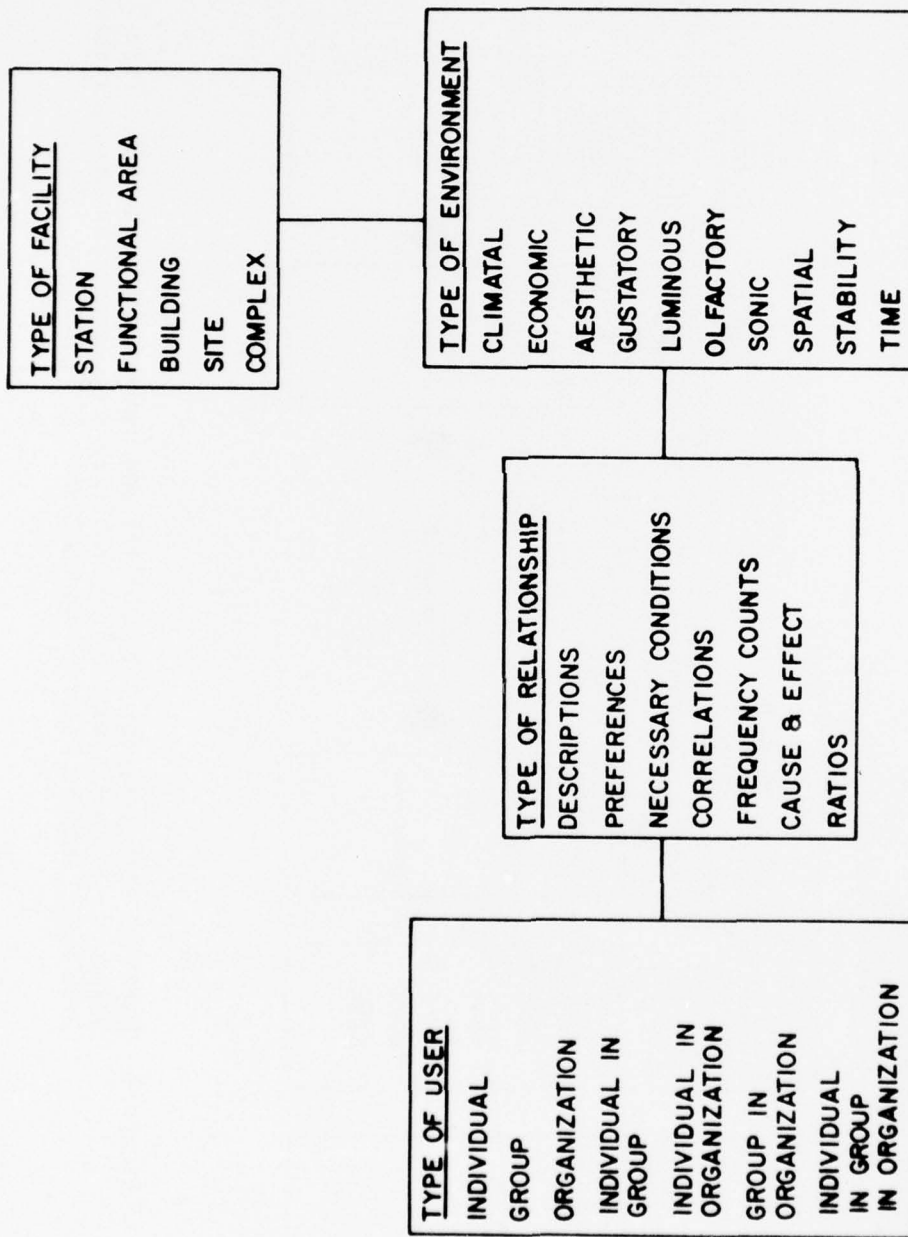

Figure 2. Early data categories for facilities, environments, relationships, and users. From T. A. Davis, "Systematizing Man-Environment Relations," *Man-Environment Systems*, Vol 4 (1974), p 183. Reprinted with permission of the Association for the Study of Man-Environment Relations, Inc.

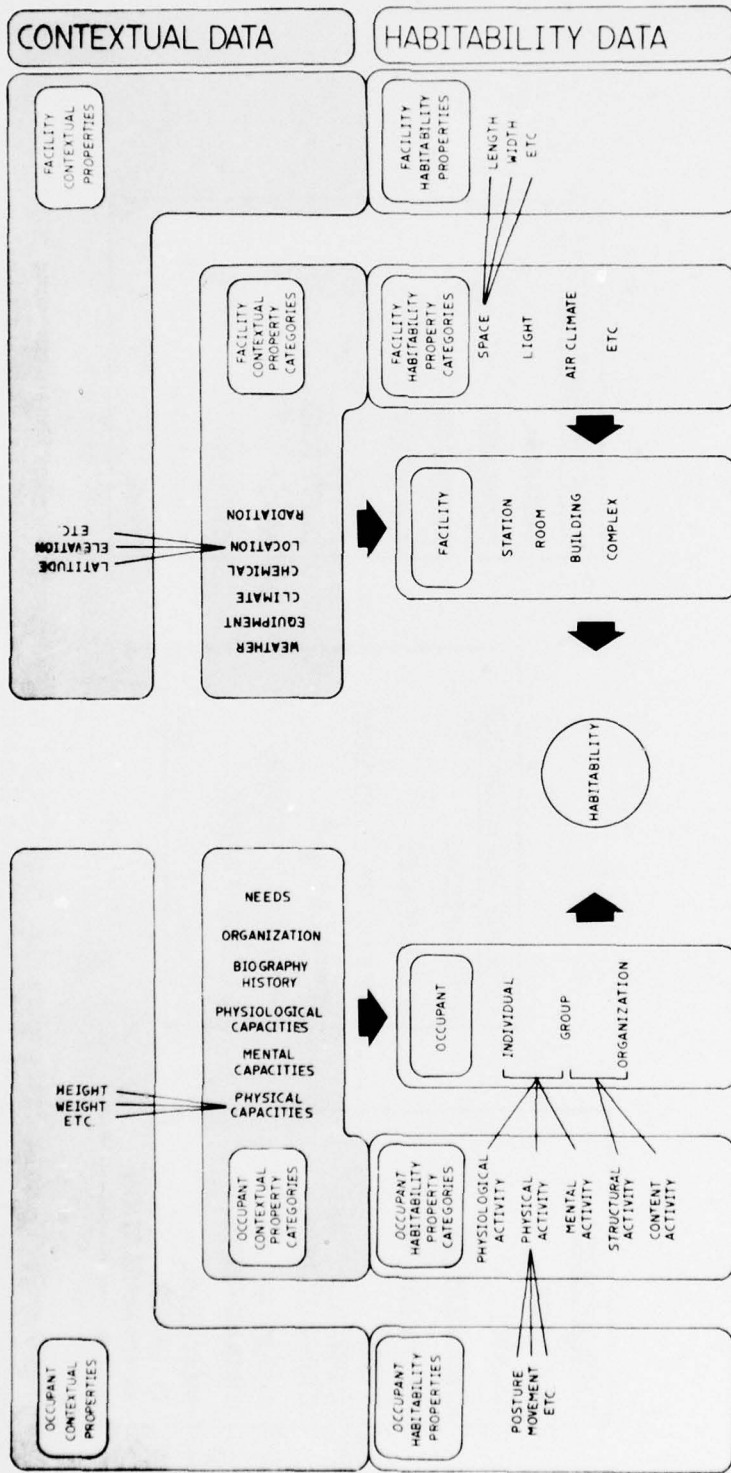

Figure 3. Detailed structure for habitability and contextual properties. From T. A. Davis, *Conceptualisation of Habitability Expressions for the Habitability Data Base*, Interim Report D-68/ADA029661 (CERL, August 1976).

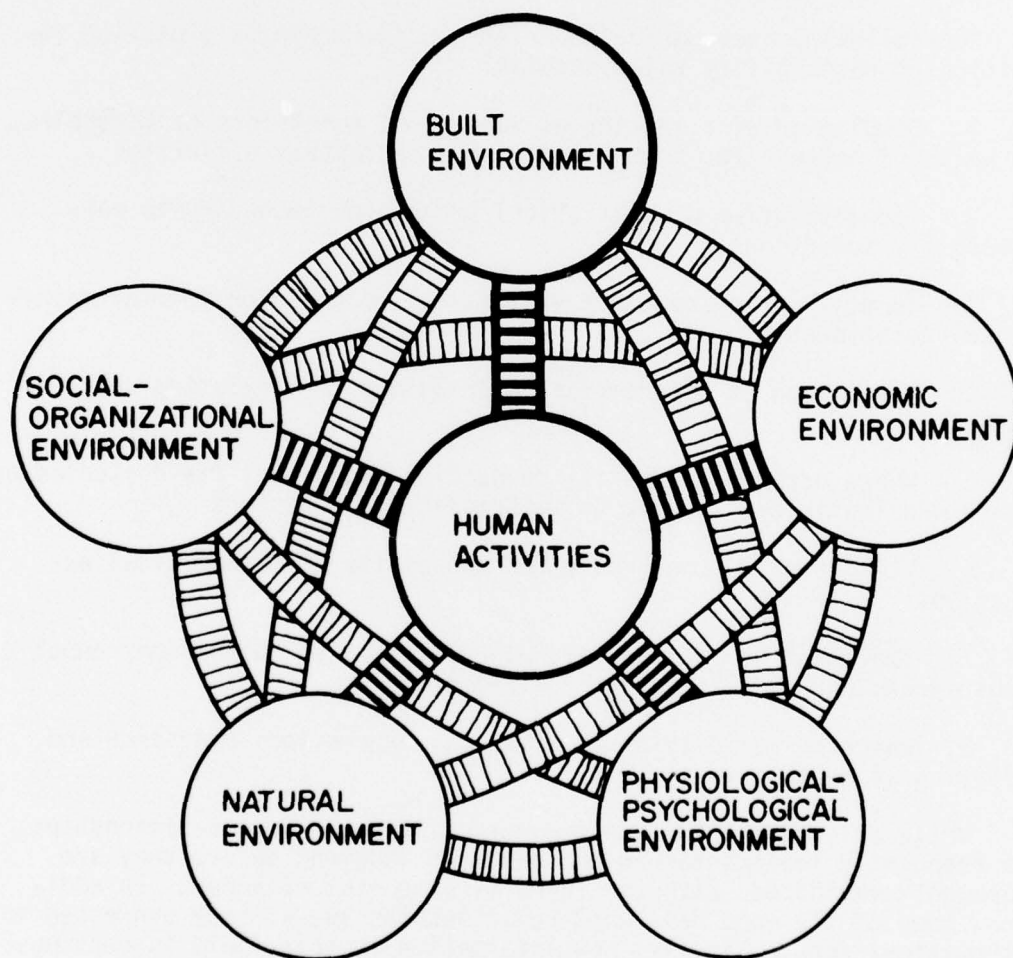

Figure 4. Structural framework for habitability (the relationships between the built environment and human activities) viewed in the context of other environments.

During the prototype phase, the concept is developed to make the conceptualized relationships predictive. This can be accomplished using data reported in research and professional literature and data collected from experiments involving people-facility relationships. However, what is measured in each study varies widely; consequently, a systematic scheme for structuring existing data and results must be formed. Quantified predictability can be derived through probability inductions or other methods and expressed in some form of mathematical expression.⁵ Once predictive expressions are available, they should be validated through field tests before they are applied in an implementation phase.

The following steps are appropriate in developing a prototype definition of habitability relationships:

1. Completion of a listing of variables, dimensions of variables, and units of measure for "completion" of a conceptual definition
2. Identification of statistical procedures necessary to make probability inductions
3. Identification of other statistical methods for forming mathematical relationships
4. Derivation of mathematical expressions from existing data, if possible
5. Where data do not exist, conducting additional field studies as needed and feasible to arrive at mathematical expressions
6. Field testing the prediction capability of mathematical expressions
7. Implementing validly defined relationships between personnel requirements and architectural requirements
8. Checking validity of mathematical expressions over time and modifying as necessary.

While all eight steps are theoretically necessary, relationships are frequently implemented on the basis of judgment before they are thoroughly validated, although there is some risk of error. In addition, some of the more developed relationships are already expressed in mathematical form. Finally, new information in this field is continually being added. Relationships which are reasonably valid could be

⁵T. A. Davis, *Conceptualization of Habitability Expressions for the Habitability Data Base*, Interim Report D-68/ADA029661 (CERL, August 1976).

incorporated in existing technical manuals (5-800 series), in the Department of Defense *Construction Criteria Manual*,⁶ or in design guide documents.

⁶*Construction Criteria Manual*, DOD 4270.1M (Department of Defense, 1972).

3 DEVELOPMENT OF A HABITABILITY DATA BASE

Description

The Habitability Data Base (HDB) was developed to provide a means for collecting, analyzing, storing, and retrieving data relating personnel requirements to architectural requirements. QCR 1.01.012 cites two main uses for the HDB: to support criteria development and to support habitability research.

The HDB supports research primarily by providing input for development of an objective definition of habitability as described in the previous chapter.

In supporting criteria development, the HDB fits into an overall scheme for criteria generation, communication, and evaluation. The data base is most useful in criteria generation, which is a responsibility of the Chief of Engineers (AR 415-20).⁷ As shown in Figure 5, human requirements are established from objectives of organizations, groups, and individuals. Corresponding habitability criteria can then be developed based on research data and professional literature, and can be judged as to whether they are appropriate to the requirements. The HDB collects, classifies, and stores this literature for quick access when needed in developing valid habitability criteria.

Summary of Progress

The HDB evolved from an expressed need to a prototype system ready for evaluation. Conceptualization of the content of habitability (as described in Chapter 2) delineated what should be contained in an HDB; i.e., what should be collected and how it might be classified.

Lane⁸ reviewed available information systems and classification schemes to determine their applicability to habitability data and found no existing system capable of adequately accommodating such data. Therefore, a series of tasks (Table 1) necessary in developing a prototype habitability data base was contracted to the Library Research Center at the University of Illinois at Urbana-Champaign.

This series of tasks has resulted in a prototype HDB which contains approximately 10,000 eighty-character lines of habitability data on

⁷*Project Development and Design Approval*, AR 415-20 (Department of the Army, May 1974).

⁸N. D. Lane, *An Evaluation of Architectural Information Systems*, Interim Report D-41/ADA001616 (CERL, October 1974).

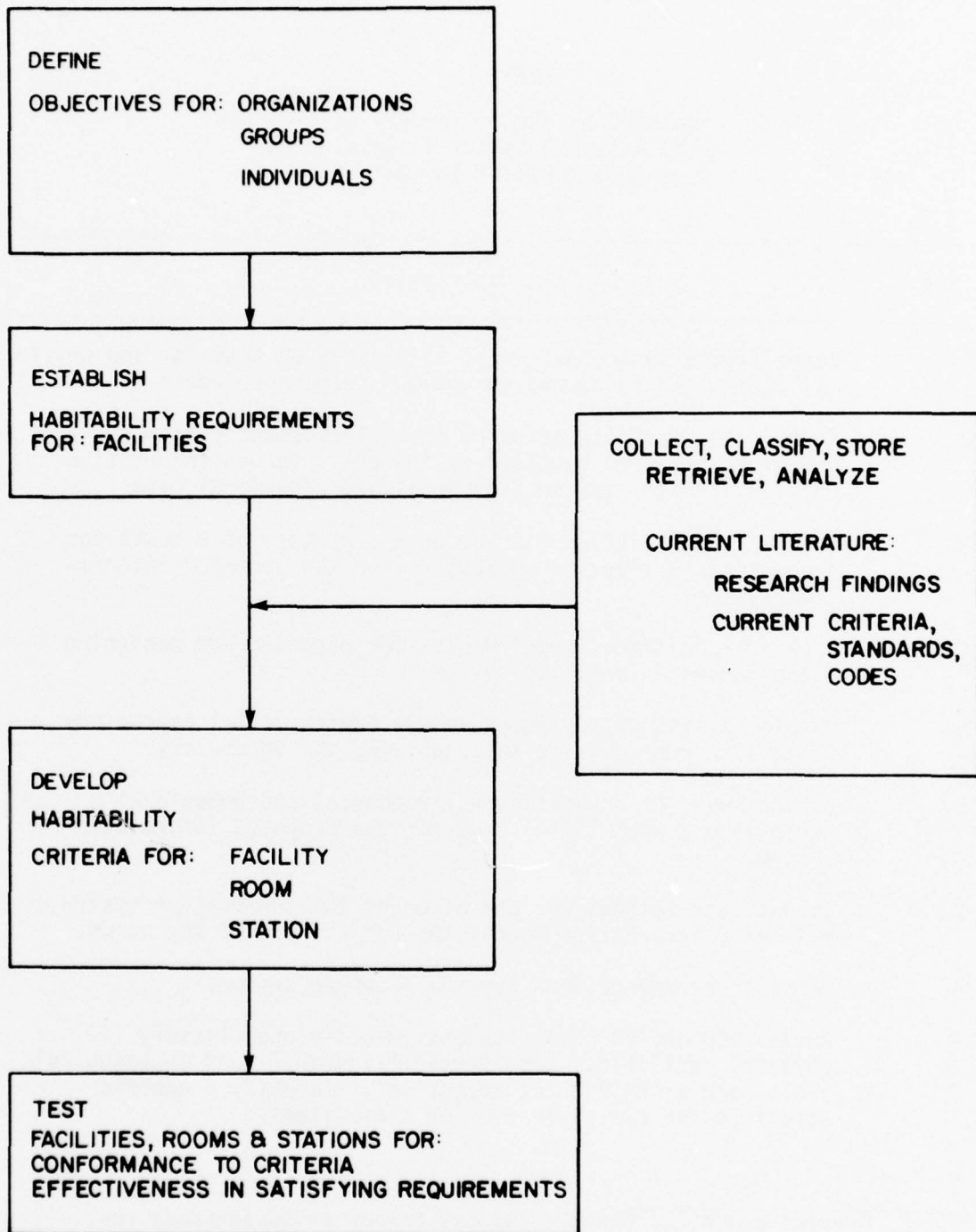

Figure 5. Major steps in habitability criteria generation and validation.

Table 1

Tasks Completed by the University of Illinois
Library Research Center in Developing
a Prototype Habitability Data Base

Task	Description
1.	Identify available sources of literature on behavior and physical design and recommend an optimal search procedure.
2.	Assess the feasibility of using the relationship sentence structure proposed by CERL* as the basis for an information retrieval system for environmental and behavioral data.
3.	Evaluate the relationship sentence structure as a basis for generating an indexing vocabulary for the proposed information system.
4.	Identify additional requirements for planning and designing the proposed information system.
5.	Develop a list of key words in the environmental psychology field as a prerequisite to organizing the vocabulary.
6.	Explore ways of organizing environmental and behavioral terms into a useful thesaurus for the proposed information system.
7.	Investigate methods for operation of the information system, primarily information access through the use of key words.
8.	Provide recommendations for the proposed system.
9.	Review DOD and DA documents and identify and classify physical facilities, architecturally significant sociological goals, and architectural objectives. Identify a generic structure for classification of these items.

*D. L. Dressel and R. L. Brauer, *Initial Report on Systemizing Information to Identify and Relate Behavior and Physical Design Parameters*, Preliminary Report D-4/AD757627 (CERL, March 1973).

Table 1 (Cont'd)

Task	Description
10.	Search literature published in 1970-71 relevant to goals and objectives identified in task 9 and identify useful criteria for judging whether they should be included in the data base.
11.	Recommend structure, content, and criteria for summarizing man-environment relationships determined in research reports and indicating the reliability of the research design and validity of the reported data.
12.	Recommend a structure for an indexing procedure.
13.	Recommend a structure and content of an appropriately indexed data base and thesaurus.
14.	Identify existing information systems providing access to documents which are potential sources for a habitability data base.
15.	Search the literature relevant to the field of man-environment relations and obtain a minimum of 500 documents to screen for relevance to the HDB.
16.	Obtain full copies of the documents which the literature search indicated should be evaluated for inclusion in the HDB.
17.	Uniquely identify each document and determine its relevance to the HDB.
18.	Provide an abstract for each relevant document in the data base.
19.	Develop a procedure for selecting man-environment relationship statements from document text, and code each statement to a generic matrix.
20.	Modify and adapt the natural language information retrieval system (known as SMART) by reprogramming it to process habitability data.
21.	Prepare an operational thesaurus for SMART based on the subject matter to be included in the HDB.

Table 1 (Cont'd)

Task	Description
22.	Develop programs capable of retrieving habitability data from numerical access codes.
23.	Key punch, enter, and store data from 10,000 data cards.
24.	Develop access to the HDB via currently available remote, low-speed terminals.
25.	<p data-bbox="418 814 1003 844">Draft two operation manuals for the HDB:</p> <ul style="list-style-type: none"> <li data-bbox="418 873 1256 932">a. A technical manual describing procedures for managing the HDB <li data-bbox="418 961 1284 1079">b. A manual describing procedures for accessing and querying the HDB, written in simple language for people who are not trained in computer terminal operations or programming.
26.	Evaluate access procedures, programs, and equipment.
27.	Reprogram the HDB for the DEC-10 System.
28.	Reprogram the HDB from batch mode to interactive mode.
29.	Modify access programs to provide an AND-OR combination in interactive mode and to improve document identification displays.
30.	Modify manuals to be compatible with program changes.

academic facilities. Of the more than 2000 documents whose abstracts were reviewed, only about 800 appeared relevant. Each of these 800 was read, and 115 documents (including 12 Department of Defense (DOD) and Department of the Army (DA) documents) were identified as actually providing relevant data.

Interactive access programs using remote terminals are now operational. Three programs based on Boolean algebra logic--AND,OR, and AND-OR combination--provide access to the data via numerically coded categories of data. Access to bibliographic information on sources of data is provided by a program called BIBAX. To obtain a complete listing of all statements stored in the data base derived from specific documents, a program called DOCAx is used.

A natural language access program called SMART is also available. This program allows system users to employ their own words to extract relevant data.

Thus, the HDB has moved from conceptualization into a prototype. Field evaluation of the prototype must be completed before recommendations for a final implementable system are presented.

Summary of Results of Field Input

While the programs for the prototype HDB were being written and data were being extracted from documents and coded, the University of Illinois computer system for which the programs were being written (called PLORTS) was discontinued and replaced by a new system (called DEC 10). The introduction of the DEC 10 system, which occurred at about the time the programs were to become operable, required that all files and programs be modified. As a result, two decisions were made. The first was to use the 1-week period when PLORTS programs were operable to obtain field input from potential users. The second was to modify programs to fit the DEC 10 system and use the field input in making operational improvements at the same time. The change in computer systems thus delayed field evaluation and completion of the prototype phase but provided a means for including access features which were not feasible with the old computer system. The field input investigation and results are summarized below.

Participants

Individuals at CERL, the Office of the Chief of Engineers (OCE), U.S. Army Training and Doctrine Command (TRADOC) Headquarters, U.S. Army Forces Command (FORSCOM) Headquarters, the Corps of Engineers Norfolk District office, and Fort McPherson, GA, participated.

Procedures

Participants were told that the purpose of the field test was to obtain their input and comments. They were introduced to the prototype

HDB through a brochure (included in the appendix) describing its structure, content, and purpose. A telephone-coupled computer terminal was provided where none was available. Participants completed a questionnaire before using the data base. After trying out the data base (during which many technical problems occurred), participants completed another questionnaire. In addition, informal comments were obtained during the procedures.

Results

The major results derived from the informal comments received and impressions formed during field visits and from questionnaire responses were:

1. Expectations were very high regarding the possibilities the computer offered for quick retrieval of regulations (requirements, criteria, etc. from DOD *Construction Criteria Manual*, Army Regulations, Technical Manuals, etc.) on specific facilities, subsystems, and topics. The interest in field operations seemed to be more for a general retrieval system than for one on habitability alone.

2. OCE and CERL personnel showed a general interest in research data; however, others showed less interest in such data.

3. Interest in specific subjects, which varied from organization to organization and individual to individual, seemed to be related to current problems. Some participants seemed to be interested in compiling lists of criteria for communication to others, while others who were familiar with criteria in regulations were interested in backup or supplementary information, particularly where criteria were not clear.

Directions for Future Development

The prototype HDB is nearly complete. The implementation phase will move toward an operational information analysis center, as described in AR 70-22.⁹

Completion of the Prototype

At the end of the FY 75 work only two steps remained before completion of the prototype HDB: conducting a field evaluation of the prototype HDB and writing a final technical report on it. The report will provide a complete description, summarize results of the field evaluation, and provide recommendations for an operational HDB.

⁹*Centers for Analysis of Scientific and Technical Information*, AR 70-22 (Department of the Army, March 1971).

Development of an Information Analysis Center

The activities of an information analysis center for a specific subject area are virtually identical to those required for operating the HDB:

1. Acquiring scientific and technical results (data) from all possible sources
2. Analyzing information
3. Evaluating and condensing information
4. Storing information in detailed and condensed forms for retrieval by a variety of users
5. Providing user services.

An effort has been initiated to establish and fund an Information Analysis Center on Man and the Built Environment. Initial funding was requested for FY 76. FY 76 and 77 would be devoted to establishing the center, with full operation scheduled for FY 78.

The major advantage of having HDB operations funded as an information analysis center is that it would not be necessary to use research and development money to provide collection, classification, analysis, and dissemination services on an ongoing basis. Research staff members would be freed to apply the information to facility delivery problems rather than required to spend time on collection, classification, storage, and retrieval problems. However, they could assist an information analysis center in maintaining content and structure of information and in completing analyses.

Until funding is received for the information analysis center, some advance planning activities are scheduled to prepare the HDB operations for implementation; specifically, expanding it in scope from the scale of the prototype.

4 CONCLUSIONS

Significant progress is being made in developing an objective definition of relationships between personnel requirements and architectural requirements and in developing a means for collecting, classifying, storing, retrieving, and analyzing such relationship data. The objective definition provides a means for dealing systematically with habitability data, while the data base provides a way of managing habitability data. Both of these pioneering efforts have evolved to the point where payoffs are imminent. Habitability data can be incorporated in Corps of Engineers procedures and used to formulate and validate requirements and criteria.

APPENDIX:

AN INTRODUCTION TO THE PROTOTYPE HABITABILITY DATA BASE

Introduction

This brief overview of the Habitability Data Base (HDB) presents some of its purposes and proposed uses, the scope of the subject matter it contains, and short explanations of the six substantively different access modes. Each kind of statement that has been classified, coded, and stored is described.

Purpose

The HDB is meant to serve both as a research tool and an operational tool in the Corps of Engineers facility delivery system.

As a research tool, the data base provides a structure within which to collect, classify, and code data toward an objective definition of military habitability; i.e., military personnel needs in constructed facilities.

As an operational tool, the data base provides ready access both to Army regulations and to the general literature on habitability. It should provide information to support the four principal phases in delivering facilities: planning, programming, design, and evaluation (of concepts, designs, and finished structures).

Exclusions

The HDB does not cover the entire field of architecture. Information primarily concerned with the art of design or with the specification of design solutions--i.e., specification of materials, equipment, etc.--is specifically excluded. At present, the content of the data base is limited to academic facilities.

Accessing Data

There are six substantively different modes of accessing the data: (1) DA facility code numbers, (2) generic habitability words, (3) statement content codes, (4) document summary statements code, (5) natural language (SMART) commands, and (6) bibliographic citation numbers.

1. Habitability data contained in DA regulations on the subject of academic facilities can be accessed by specifying the facility class and/or the construction category and/or the functional area codes.

2. All habitability data (including DA regulations) are subject coded to a list of descriptions of occupants and facilities. If the topic being studied contains one or more of these subjects, data about them can be retrieved in either the "AND" or "OR" mode. The generic words are as follows:

Functional settings are coded to: station, room, building, moving vehicle, constructed outdoor, and natural site.

Environmental topics are coded to: spatial, climatal, light, sound, other electromagnetic, chemical, particulates, gases, motion, time, economic, and aesthetic.

Occupants are coded to: individual, group, organization, individual in group, and group in organization.

Individual and group activities are coded to: (posture) lying, sitting, standing; (involvement) passive, active, interactive with people, interactive with things, interactive with both people and things.

Organizational functions are coded to: administrative, assembly, maintenance, production, research, residence, social or recreational, and training.

3. All habitability data (including DA regulations) are also coded to one of four statement content categories: human requirement, performance criterion, relationship data, and content data. These codes can also be used in the "AND" or "OR" mode.

Note: All three of the above substantively different access modes are structurally alike for access purposes; i.e., they are all accessed through numeric codes using either the "AND" or "OR" mode.

4. All habitability data (including DA regulations) in all statement content categories are accessible via an HDB document number. (An accession number is assigned to each document from which data are taken.)

5. All habitability data (including DA regulations) on lighting and color are also accessible by using natural language commands in sentence or paragraph form. The accessing program called SMART matches the inquiry to the data base and prints out the most relevant habitability statements.

6. Bibliographic citations are available for each habitability statement via an HDB document number.

Habitability Statements

The word habitability refers to the degree of fit (i.e., the quality or effectiveness) of built facilities to the occupants of the facilities for: (1) occupant task performance, (2) occupant health and safety, and (3) occupant comfort and satisfaction. To adequately describe this fit in any particular situation, data are needed from at least 10 different categories: facility, facility stimulus, occupant, occupant response, the relationships between stimulus and response, observation method, facility environment, functional setting, occupant activities, and occupant descriptions. Figure A1 diagrams the relationships between these 10 categories of data in a complete habitability statement and gives examples of each category.

The HDB contains four kinds of statements about habitability, each of which records several of the 10 categories of data shown in Figure A1. These four kinds of statement are relationship data, content data, human requirements, and performance criteria. They are defined and diagrammed below.

Relationship Data Statements

Relationship data statements contain the findings of descriptive reports concerning occupant use of existing built facilities. They contain generic common names for the facility and the occupant, observed and/or measured descriptions of the facility stimuli and occupant responses to the stimuli, and descriptions of the relationships between the stimuli and responses. Figure A2 is a diagram of the data categories used in relationship data statements as they are found in research or descriptive reports.

An example of a relationship data statement from a research report in the data base is as follows:

(HDB code 3, col. 19) "Data: The control group achieved a mean attention time of 22.4 seconds, and the test group 40.4 seconds--an increase of 80 percent. Furthermore, the test group excelled in every trial, with the closest level of attention exceeding the control group by 13 percent, and the greatest discrepancy representing an increase of 153 percent.

The second experiment (attention duration) recorded the continued attention to a designated visual aid, after acquisition was attained. The test class attended an average of 78.9 seconds--54 percent more than the 51.2 second average for the control group.

In the first trial, with auditory support, the test group exceeded the control group by 25 percent longer attention. In the second trial the test group exceeded by 101 percent longer attention." (HDB document no. 415).

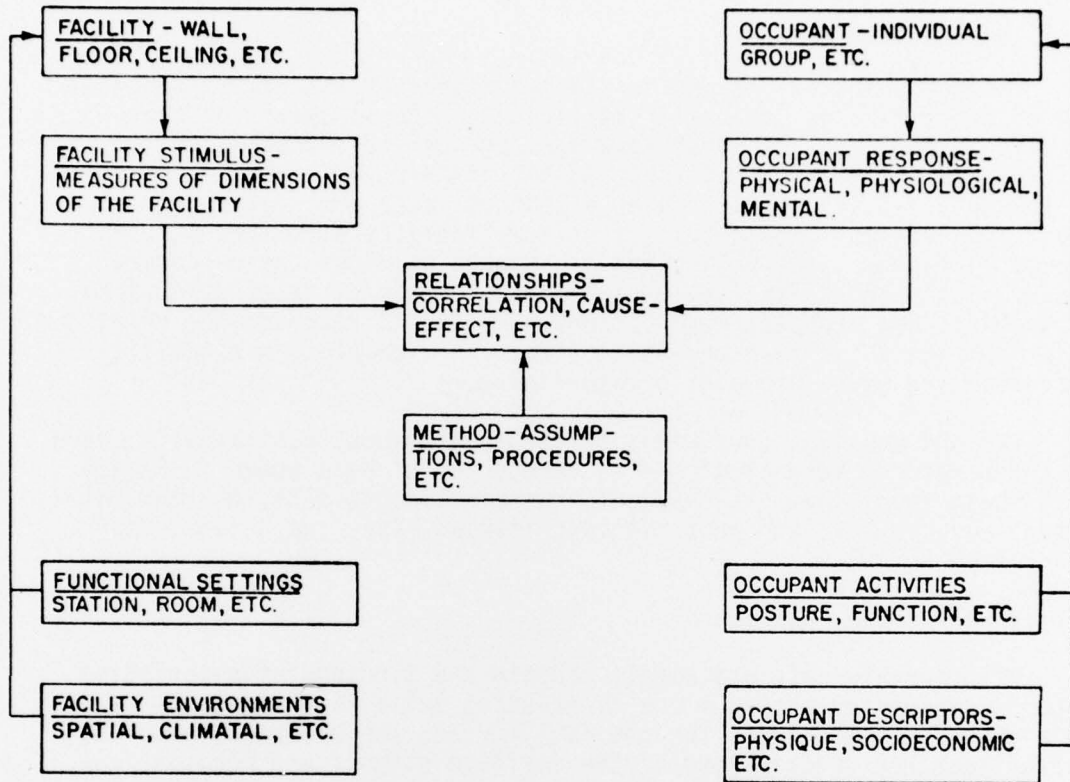

Figure A1. Data categories of habitability statements.

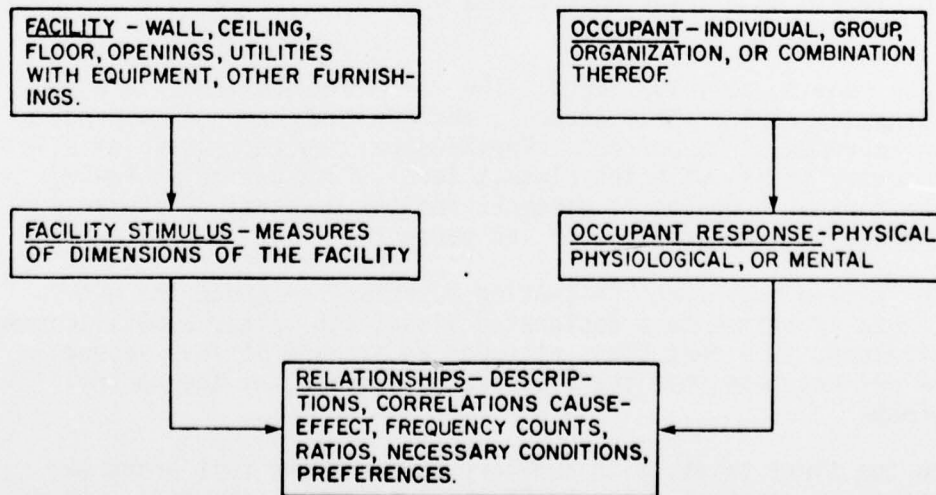

Figure A2. Relationship data statements.

Context Data Statements

Context data statements are reports of the generalization or prediction variables which give a fuller understanding of the relationship data statements. Context data statements contain descriptions of the physical context in which the facility stimulus occurred, the context (social, psychological, etc.) in which the occupant response occurred, and the methodological context in which the relationship was recorded. Figure A3 is a diagram of context statements which gives examples of the five context data categories: observation method (assumptions, procedures, etc.), functional settings (station, room, etc.), facility environments (spatial, climatal, etc.), occupant activities (function, posture, etc.), and occupant descriptions (physique, socioeconomic, etc.).

An example of a DA context data statement contained in the data base is as follows:

(HDB code 4, col. 19) "A. Definition of facility. A general academic classroom is one which supports approved training programs and provides accommodations only for classroom lecture and instruction using standard chairs with fixed table arms in standard side-by-side arrangement, and space for instructor station utilizing small, portable training aids. Classrooms requiring space per seat greater than given in Table 3-66, such as applied subjects classrooms, special purpose classrooms, laboratory classrooms, or seminar type classrooms, are not considered general academic classrooms for the purpose of these criteria." (HDB document no. 0008).

An example of a context data statement from a research report is as follows:

(HDB code 4, col. 19) "Occupants: Two fifth-grade classes of 21 students each participated.

Background:

1. Attention acquisition--using variable lighting as a tool by the teacher to attract or transfer the attention of student to the proper visual stimulus.
2. Attention duration--using reinforcing brightness patterns to hold the attention of students upon visual aids used as a source of instruction.

Method: The experiments were conducted in two almost identical classrooms, one with standard overall lighting, and the other with overall lighting, plus several circuits of high lighting.

One class was used as the control group, and the other exposed to reinforcing light techniques during instructions. All

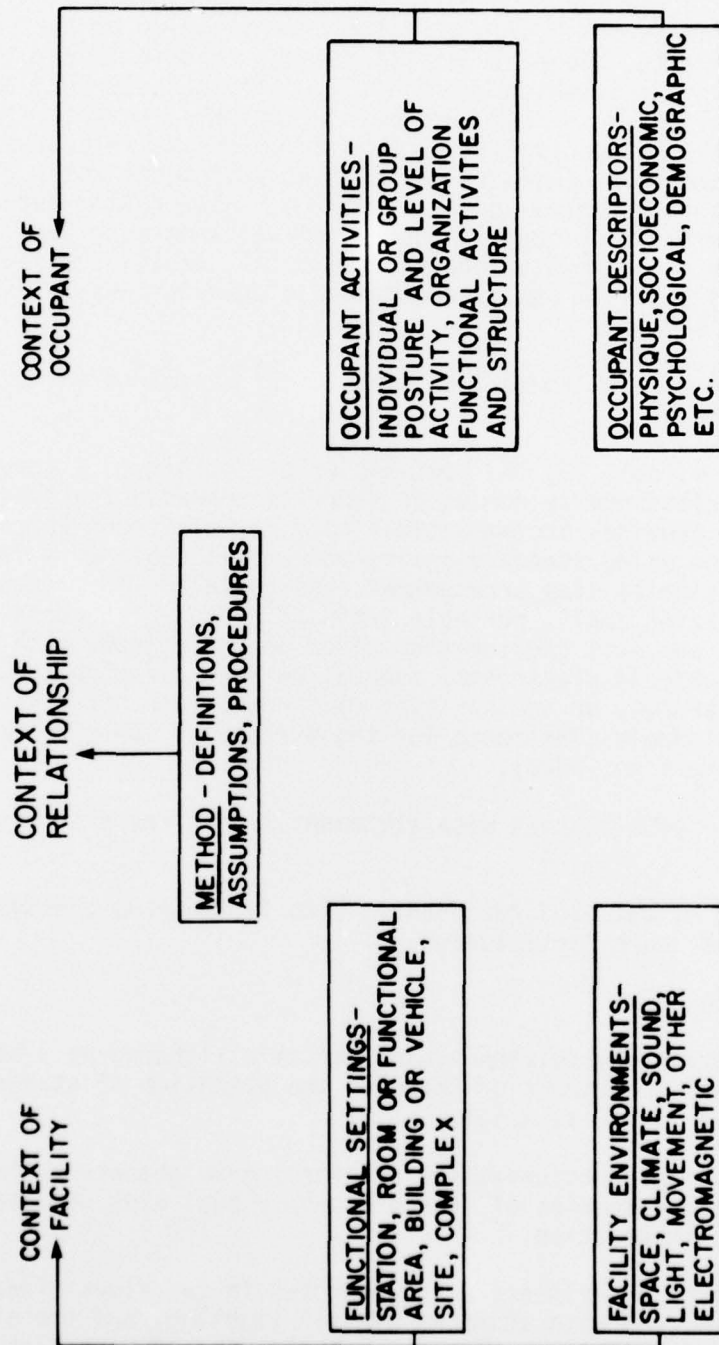

Figure A3. Context data statements.

observations were made in specially constructed observation rooms through one-way mirrors. Class activity was also monitored and recorded on closed circuit television.

The first experiment (attention acquisition) utilized lesson exercises requiring 20 transfers of attention between two visual aids. The visuals were arranged so as to require the pupils to turn 90 degrees or more from one visual to the other.

Averages were derived from two attention duration trials. The first trial utilized a visual aid with auditory reinforcement, i.e., the teacher read from the visual while showing it. The second trial was similar but with the teacher silent." (HDB document no. 415).

Human Requirement Statements

Human requirement statements, which are defined as in the *CSI Manual of Practice*¹⁰ contain the language of human needs rather than the technical language of quantifiable attributes of facilities. They are stipulations of one (or more) attribute, dimension, setting, or environment that ought to be provided for human habitation of a facility. Because they use the same data categories, statements of this kind are also used to make statements of habitability objectives for research reports or for reports describing existing facilities. In the data base, these statements are labeled "objectives."

Each human requirement statement must contain as much data as possible about the occupant, his/her activities, and expected or preferred responses to facility stimuli. The statement also stipulates one or more of the following facility data categories in order to accommodate the occupant: facility, facility dimension, functional setting, and/or facility environment. Figure A4 diagrams objectives for human requirement statements and habitability reports.

As an example, the data base contains the following DA human requirement statement with facility implications:

(HDB code 1, col. 19) "5-1.2.8. Special emphasis shall be placed on the quality of the architectural design since it vitally affects the longevity, economics, usefulness, efficiency, attractiveness, and livability of most facilities. A prime requirement of the architectural design shall be the attractiveness of both the interior and exterior of facilities." (HDB document no. 0008).

¹⁰*CSI Manual of Practice: Performance Specifications*, MP-35 (The Construction Specifications Institute, Inc., May 1972).

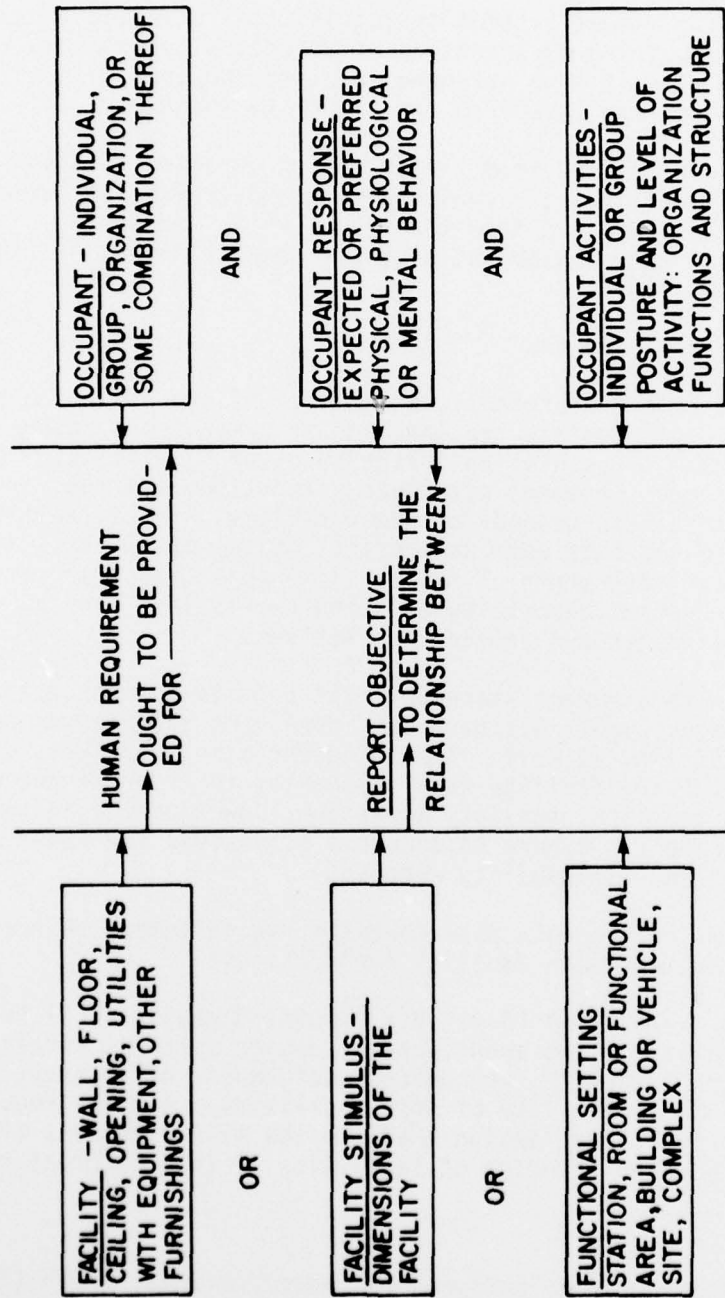

Figure A4. Human requirement and report objective statements.

An example of a research report objective is as follows:

(HDB code 1, col. 19) "Objective: This study investigates the effectiveness of lighting in the form of reinforcing brightness patterns as an aid to the classroom teacher in attracting student attention to, and holding attention upon, visual instructional media." (HDB document no. 415).

Performance Criteria Statements

Performance criteria statements, which also follow the Construction Specification Institute definition, contain descriptions of a facility's level of performance required to satisfy a habitability requirement. Therefore, while the requirement contains all possible data about the occupant activities and expected or preferred behavior, the criteria contain all possible technical, quantified data about the facility, facility stimuli, functional setting, and facility environments. They also contain an indication of the occupant, occupant activity, or response for which the facility data are stipulated. Performance criteria include measures of facility dimensions such as square feet of floor space per person, the shape of the space, and the light levels. They specify the performance of a facility which is to be built and standards against which the performance of a facility can be evaluated. Figure A5 is a diagram of criteria statements. Figure A5 is like Figure A4 (human requirement statements) except the "and's" and "or's" are switched, and the term "measures of" is added to dimension of the facility in the facility stimulus box.

An example of a DA performance criterion contained in the data base is as follows:

(HDB code 2, col. 19) "5-1.6 Provisions for the physically handicapped: unless otherwise required for a particular function, passenger elevators shall not be provided expressly for the physically handicapped." (HDB document no. 0008).

An example of a performance criterion from a research report is as follows:

(HDB code 2, col. 19) "Criteria: Flexible and variable lighting systems in a classroom can exert a catalytic effect in influencing pupils to transfer their attention to visual teaching aids, and can be a significant and effective augment to the cognitive process." (HDB document no. 415).

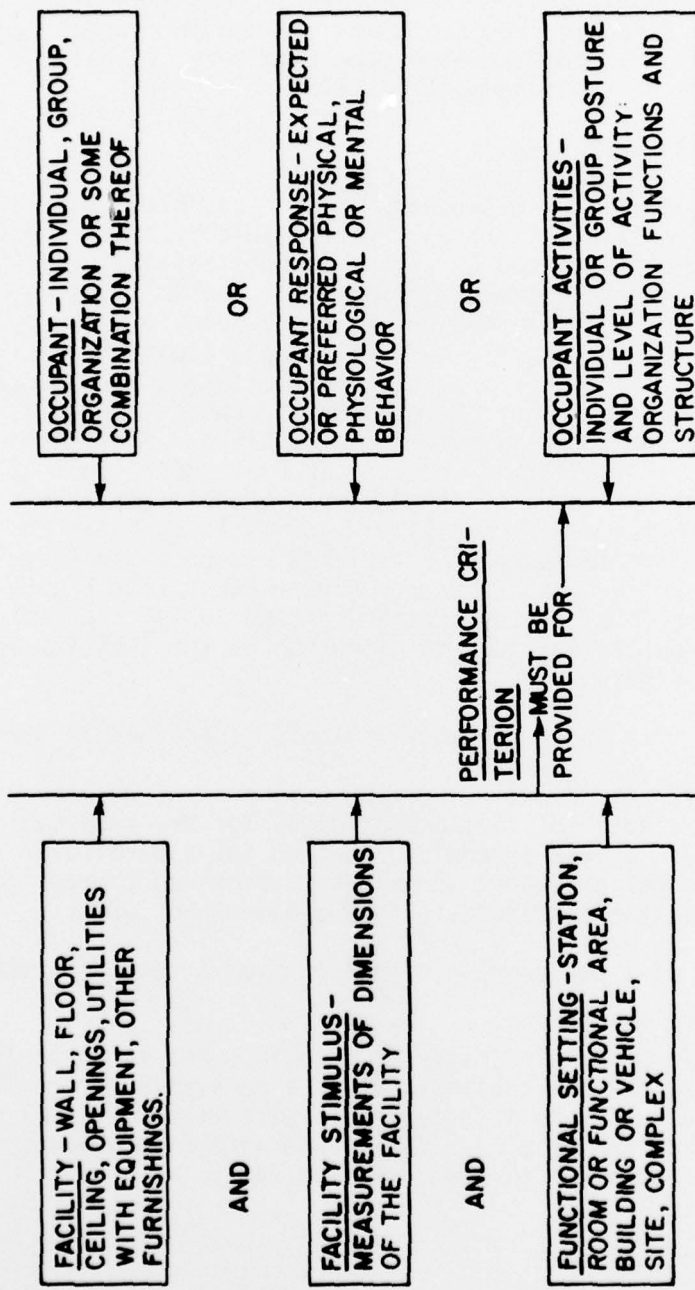

Figure A5. Performance criteria statements.

REFERENCES

- Centers for Analysis of Scientific and Technical Information*, AR 70-22 (Department of the Army, March 1971).
- Construction Criteria Manual*, DOD 4270.1M (Department of Defense, 1972).
- CSI Manual of Practice: Performance Specifications*, MP-35 (The Construction Specifications Institute, Inc., May 1972).
- Davis, T. A., *Conceptualization of Habitability Expressions for the Habitability Data Base*, Interim Report D-68/ADA029661 (U.S. Army Construction Engineering Research Laboratory [CERL], August 1976).
- Davis, T. A., "Systematizing Man-Environment: Toward A Model of Man-Environment Relations," *Man-Environment Systems*, Vol 4 (1974), pp 181-184.
- Dressel, D. L. and R. L. Brauer, *Initial Report on Systemizing Information to Identify and Relate Behavior and Physical Design Parameters*, Preliminary Report D-4/AD757627 (CERL, March 1973).
- Lane, N. D., *An Evaluation of Architectural Information Systems*, Interim Report D-41/ADA001616 (CERL, October 1974).
- Project Development and Design Approval*, AR 415-20 (Department of the Army, May 1974).

CERL DISTRIBUTION

Chief of Engineers
ATTN: DAEN-ASI-L (2)
ATTN: DAEN-RDL
ATTN: DAEN-MCE-A/R. Cramer
Department of the Army
WASH DC 20314

Defense Documentation Center
ATTN: TCA(12)
Cameron Station
Alexandria, VA 22314