

AD-A041 192

OKLAHOMA STATE UNIV STILLWATER FLUID POWER RESEARCH --ETC F/G 13/5
DEVELOPMENT OF A STABILITY MONITOR/CONTROLLER FOR MATERIAL HAND--ETC(U)
APR 77

DAA653-76-C-0144

NL

UNCLASSIFIED

4 of 22
AD41192



ADA041192

BS (2)

DDP
JUN 29 1971
C

DEVELOPMENT OF A STABILITY MONITOR/CONTROLLER
FOR MATERIAL HANDLING EQUIPMENT

Phase II - Hardware Development

Prepared By Personnel of

FLUID POWER RESEARCH CENTER
Oklahoma State University
Stillwater, Oklahoma

April 1977

Final Report

Prepared For

U.S. ARMY MOBILITY EQUIPMENT RESEARCH
AND DEVELOPMENT COMMAND
Fort Belvoir, Virginia

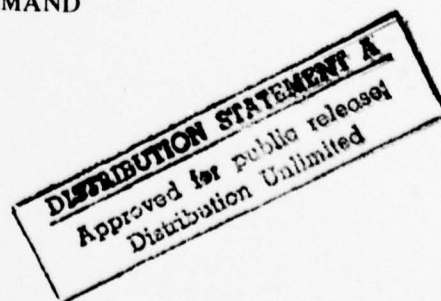
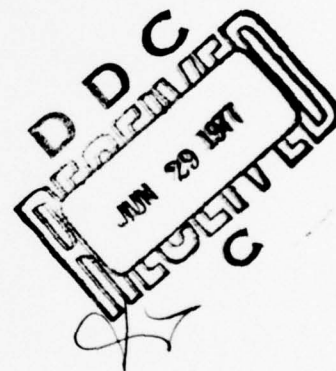

UNCLASSIFIED

SECURITY CLASSIFICATION OF THIS PAGE (When Data Entered)

REPORT DOCUMENTATION PAGE		READ INSTRUCTIONS BEFORE COMPLETING FORM
1. REPORT NUMBER	2. GOVT ACCESSION NO.	3. RECIPIENT'S CATALOG NUMBER
4. TITLE (and Subtitle) Development of a Stability Monitor/Controller for Material Handling Equipment • Phase II		5. TYPE OF REPORT & PERIOD COVERED Final rept. 21 June 1976 - 28 February 1977
6. AUTHOR(s) Staff of the Fluid Power Research Center		7. PERFORMING ORG. REPORT NUMBER
9. PERFORMING ORGANIZATION NAME AND ADDRESS Fluid Power Research Center Oklahoma State University Stillwater, OK 74074		8. CONTRACT OR GRANT NUMBER(s) DAAG53-76-C-0144
11. CONTROLLING OFFICE NAME AND ADDRESS U.S. Army Mobility Equipment Research and Development Command, Procurement and Production Office, Fort Belvoir, VA 22060		10. PROGRAM ELEMENT, PROJECT, TASK AREA & WORK UNIT NUMBERS
14. MONITORING AGENCY NAME & ADDRESS (if different from Controlling Office) ONRRP Room 582 Federal Building 300 East 8th St., Austin, TX 78701		12. REPORT DATE April 1977
16. DISTRIBUTION STATEMENT (of this Report) Approved for Public Release: Distribution Unlimited		13. NUMBER OF PAGES 80
17. DISTRIBUTION STATEMENT (of the abstract entered in Block 20, if different from Report)		15. SECURITY CLASS. (of this report) Unclassified
18. SUPPLEMENTARY NOTES N/A		15a. DECLASSIFICATION/DOWNGRADING SCHEDULE
19. KEY WORDS (Continue on reverse side if necessary and identify by block number) Material Handling Equipment Safety Stability Control		
20. ABSTRACT (Continue on reverse side if necessary and identify by block number) (Over)		

407263

4/B

UNCLASSIFIED

SECURITY CLASSIFICATION OF THIS PAGE(When Data Entered)

The purpose of this two-phased study is to investigate the feasibility of developing a stability monitor or controller suitable for material handling equipment (MHE). Recommendations were to be made as to the optimal method (Phase 1). Phase 2 required the design, fabrication, and testing of an exploratory system to demonstrate feasibility.

This report documents Phase 1 of the investigation. The exploratory system is a microcomputer-based system which performs calculations as derived in Phase 1. The system hardware is documented. Installation instructions for the exploratory system are provided such that the system can be installed on a vehicle different from the one used in testing. The results of the test program are presented.

UNCLASSIFIED

SECURITY CLASSIFICATION OF THIS PAGE(When Data Entered)

TABLE OF CONTENTS

List of Figures		ii
List of Tables		ii

<i>Chapter</i>	<i>Title</i>	<i>Page</i>
I	INTRODUCTION	1
II	SYSTEM CONFIGURATION	3
III	SYSTEM SOFTWARE	7
IV	INSTALLATION AND OPERATION	15
V	TESTING PROGRAM	23
VI	CONCLUSIONS AND RECOMMENDATIONS	39
	APPENDIX A	43
	APPENDIX B	61
	APPENDIX C	73

White Section
Bolt Section

NTS
 P-30
 UNANNOUNCED
 DISTRIBUTION

DISTRIBUTION/AVAILABILITY CODES

Dist. Avail. and/or SPECIAL

A

LIST OF FIGURES

<i>Figure</i>	<i>Title</i>	<i>Page</i>
3-1	Program Flow Chart	11
3-2	Constant Storage	14
4-1	Strain Gauge Interconnection	17
4-2	Strain Gauge Calibration	20
5-1	Test Plan Nomenclature	25

LIST OF TABLES

<i>Table</i>	<i>Title</i>	<i>Page</i>
2-1	Major System Components	4
3-1	Program Constants	12
4-1	Transducer Interconnection	18
4-2	Portable Readout Parameters	21
5-1	Test 1 Results	27
5-2	Test 2 and 3 Results	29
5-3	Test 4 Results	32
5-4	Test 5 Results	35
5-5	Test 6 Results	37

CHAPTER I

INTRODUCTION

In order to demonstrate the feasibility of monitoring or controlling the stability of material handling equipment (MHE), an exploratory system was designed and fabricated. The MHE Vehicle Stability/Safety Exploratory System (SES) provided a means of verifying the concepts derived in Phase I and also provided a system which could be subjected to a testing program for appraisal of the approach. The system was designed incorporating sufficient flexibilities in order to allow for the possibility of a multiplicity of potential approaches which might need to be considered before an optimal approach is selected.

The SES was designed around a standard micro-computer. The intelligence of the system is not hardware dependent but rather contained within the micro-computer program. The basic algorithm for the system calls for the micro-computer to measure vehicle variables, calculate the vehicle stability, and output a warning to the operator if appropriate. The detailed specifications of the system were not known at the initiation of the design; rather, they evolved as the theoretical model evolved. The micro-computer's programmability provided the needed flexibility.

Since the primary mission was to provide verification of the concepts theoretically derived, the system hardware and software (program) has not been optimized for "production." Several aspects which seemingly result in questionable feasibility can easily be solved. Several of these are discussed in the Conclusions and Recommendations. Of course, not all of the technological and conceptual problems have been solved, and some of these are also discussed.

This report provides the detailed documentation for the system designed. Basic descriptions of both the system hardware and software are also provided. The appendices provide detailed drawings for the hardware and a listing of the program. Instructions, calibration, and operating instructions are also provided.

CHAPTER II

SYSTEM CONFIGURATION

The SES is a micro-computer based system which consists of three major subsystems – micro-computer, transducers, and interface. Although the primary purpose of a stability monitor is to provide a GO/NO GO indication, provisions have been incorporated into the system to provide a quantitative evaluation of the system performance via a portable display unit. The micro-computer, interface, and allied power condition circuitry are packaged in a standard cabinet. The circuit cards are mounted in a card rack. The cards are interconnected by a printed circuit board (mother board). The transducers are installed on the vehicle and are connected to the main unit via a terminal strip on the back of the unit.

Table 1 lists the major components which comprise the system. The manufacturer of each component is also listed.

The following sections describe the major subsystems. Drawings documenting the system are contained in Appendix A.

The micro-computer is a four-bit computer based on the Intel MCS-40 microprocessor. This computer is manufactured by Pro-Log Corporation and is an off-the-shelf unit specifically designed for dedicated control applications such as this system. The Intel microprocessor is capable of performing input/output operations, calculations, and decisions controlled by the resident program.

TABLE 2-1. Major System Components.

Designation	Description	Manufacturer	Comments
Micro-computer	PLS-403 Three Card 4040 Micro-computer System	Pro-Log Corp. Monterey, CA	
A/D	SDM 853	Burr-Brown	
P_{Lift} , P_1 , P_2	LX1470A	National Semiconductor Santa Clara, CA	
σ_m	Humphrey Precision Pendulum CP17-0601-1	Humphrey	
σ	C6-121 Strain Gauge	Bvd	or equivalent

The program storage for this micro-computer is contained in programmable erasable read-only memories (EPROM). These non-volatile devices are programmed with a commonly available unit. At any time after programming, the EPROM

can be erased by exposing it to ultraviolet light for approximately ten minutes. The device is then reprogrammed as desired. This operation can be repeated virtually an unlimited number of times. Reference [1] provides an excellent discussion of the programming and erasing of these devices and the instruments required.

TRANSDUCERS

The parameters associated with the vehicle operation (P_1 , P_2 , P_{Lift} , mast angle σ_m , and strain resulting from the side load moment σ) are measured and converted to electrical signals via appropriate transducers. The pressures are measured using solid-state transducers which contain strain gauge bridges, regulator, and amplifier within the package. These transducers output a 2.5V to 12.5V signal where 2.5V corresponds to 0 psi and 12.5V corresponds to 5000 psi.

The mast angle is measured with a Precision Pendulum. This unit is a liquid-damped pendulum with a potentiometer attached and is capable of measuring angles in the range of -45° to $+45^\circ$ from vertical. A voltage is applied across the potentiometer, and the voltage at the wiper provides the required angle indication.

The side load moment is measured via a strain gauge bridge installed in a cantilever configuration. One gauge is installed on each of the two stationary uprights and positioned to measure strains occurring on the side of the mast uprights, parallel to the long dimension of the mast. These two active gauges, one of each side of the mast assembly, form one side of the bridge. Temperature compensating gauges are installed on a separate steel block adjacent to each active gauge. The two temperature-compensating gauges form the other side of the bridge. The bridge output is a low-level signal proportional to the side load moment. Tests reveal that the linearity of this signal as a function of mast height is good except at low mast heights for the vehicle used in the exploratory work (Eaton GCLP GCL-055B).

INTERFACE

The interface provides the necessary signal conditioning and conversion from analog signals to digital. The analog-to-digital converter (ADC) is an off-the-shelf unit which is capable of 16 channels of information. The unit converts a 0-to-10 volt signal to a 12-bit binary number, where 0 volts is equal to 0 and 10 volts equal to 4095. Each individual measurement is performed in approximately 30 micro-seconds. This assembly is contained on Card A8 (Drawing FPRC-LSM-2).

In order to obtain signals from the transducers which are compatible with the ADC, signal condition is required. The pressure transducer output is 2.5 VDC to 12.5 VDC. This signal must be level-shifted. Similar considerations apply to the angle sensor. The circuitry for this level shifting is contained on Card A9. (Refer to Drawing FPRC-LSM-7.) Adjustment capability is provided on this card.

The output from the strain gauge bridge is amplified by a two-stage amplifier – first an instrumentation amplifier and then an op amp. This signal is level-shifted such

that the bi-polar signal will operate in the 0-to-10 volt range. This circuitry is contained on Card A19. (Refer to Drawing FPRC-LSM-3.)

DISPLAY

An outboard display has been incorporated into the system, allowing for display of key system parameters. This device plugs into and obtains all power and signal inputs from the main unit. The parameter to be displayed is selected by a thumbwheel switch. The output is an eight digit number in the format used by the micro-computer. (This will be discussed in Chapter III.)

SYSTEM INTERCONNECTION

The system, excluding display unit, is housed in a standard enclosure. The electronic circuitry is contained on cards in a card rack and is interconnected with a mother board. Power supplies are contained within the enclosure, which generates the appropriate voltage for the electronic circuitry. Connection to the power source is via a connector on the back of the unit. Connection to the transducer is made by a terminal strip also on the back.

Warnings to the operator are provided by two means. In the event that an unstable configuration is encountered, an audible alarm is sounded to warn the operator. In addition, a light is activated to indicate whether the instability is about the pitch axis or one of the roll axes.

CHAPTER III

SYSTEM SOFTWARE

All logic for performing the necessary calculations and decisions is incorporated in the micro-computer program. This micro-computer, as with any other computer, is programmed in binary codes. The MCS-40 is a four-bit computer — computations are performed sequentially on four-bit data words. This word length does not allow for sufficient accuracy in the calculations, and programs have been written to perform 32-bit calculations.

The calculations which must be performed are as follows:

$$\sigma_T = A\sigma_m^2 + B\sigma_m + C$$

where:

- σ_m = mast angle referenced to vertical; forward tilt is positive (rad)
- σ_T = tilt cylinder angle reference to horizontal; angle up is positive (rad)
- A,B,C = constant to relate σ_m and σ_T , empirically derived

$$F_T = A_1 P_1 - A_2 P_2$$

$$F_{TY} = F_T \cos \sigma_T$$

$$F_{TZ} = F_T \sin \sigma_T$$

where:

- F_T = force in one tilt cylinder (ft-lbs)
- F_{TY} = Y component of F_T

- F_{TZ} = Z component of F_T
 P_1 = rod side tilt cylinder pressure (psi)
 P_2 = head side tilt cylinder pressure (psi)
 A_1 = area of rod side of tilt cylinder (square inches)
 A_2 = area of head side of tilt cylinder (square inches)

$$W_{mm} = \frac{P_L A_L}{\cos \sigma_m}$$

- where: W_{mm} = weight of the movable portion of the mast (lbs)
 P_L = lift cylinder pressure (psi)
 A_L = effective area of lift cylinder (includes chain ratio if appropriate) (square inches)

$$M_{ox} = -[w_v y_v] + (-y_T) F_{TZ} - (Z_T - Z_m) F_{Ty}$$

- where: M_{ox} = x component of the counterbalance moment vector
 $[w_v y_v]$ = product of the weight of the vehicle and the y component of the position vector for the origin to the vehicle c.g.
 $(-y_T)$ = y component of $\overline{-P_T}$
 $(Z_T - Z_m)$ = Z component of $\overline{P_T - P_m}$
- $S_{pitch} = M_{ox}$
- S_{pitch} = vehicle stability about pitch axis
- $m_{cpy} = \sigma \cos \sigma_m$
- m_{cpy} = y component of imbalance moment measured by strain gauges (ft-lbs)

where: σ = moment measured by strain gauge bridge (ft-lbs)

$$M_{oy} = \left[x_v w_v + \frac{x_m w_{ms}}{2} \right] + w_{mm} \left(\frac{x_m}{2} \right) + M_{cpy}$$

M_{oy} = y component of the counterbalance moment vector

$x_v w_v$ = product of the vehicle weight and x component of vehicle (e.g., position vector) (ft-lbs)

$x_m w_{ms}$ = product of the weight of the stationary portion of the mast and the x component of P_m (ft-lbs)

$$-S_{LR} = -\lambda_{LRx} M_{ox} - \lambda_{Lry} M_{oy}$$

$$S_{RR} = \lambda_{RRx} M_{ox} + \lambda_{RRy} M_{oy} + \lambda_{RRx} (x_{R2} [w_v + w_{ms} + w_{mm}])$$

$$\lambda_{RRy} = -\lambda_{Lry}$$

where: S_{LR} = stability about left roll axis
(NOTE: The program calculates $-S_{LR}$.)

S_{RR} = stability about right roll axis

$$\lambda_{LRx}, \lambda_{Lry} = \frac{x}{\bar{\lambda}_{RR}} \text{ and } y \text{ components of the direction cosine vector}$$

$$\lambda_{RRx}, \lambda_{RRy} = x \text{ and } y \text{ components of the direction cosine vector}$$

In addition,

$$\bar{P}_T = \bar{P}_{T1} + \bar{P}_{T2}$$

$$\bar{P}_m = \bar{P}_{m1} + \bar{P}_{m2}$$

$$\bar{\lambda}_{LR} = -\bar{P}_{R5} / (\bar{P}_{R5})$$

$$\bar{\lambda}_{RR} = (\bar{P}_{R5} - \bar{P}_{R2}) / (|\bar{P}_{R5} - \bar{P}_{R2}|)$$

Note that the vehicle parameters are defined consistent with the Phase I report. Position vectors are measured with respect to the coordinate system defined in this report.

A flow chart of the program which implements these equations is shown in Fig. 3-1. The various analog parameters are measured, calculations performed, and S_{pitch} , S_{LR} , and S_{RR} are compared to limits. If any of these is outside the allowable limits (as defined by M_1 , M_{2L} , and M_{2R}), then a warning is sounded.

CONSTANT STORAGE

The vehicle-dependent constants are listed in Table 3-1. The value of the constants shown in this table reflects the geometry of the Eaton Model GLC-505B- lift truck (5000 lbs.). In order to use this system on another model lift truck, the constants in this table must be defined for the model of truck, appropriate scaling applied to the number, and then converted to computer format. Note that the scaling is required because of the integer calculations performed by the computer.

The proper method of performing this is to obtain the constant in appropriate units (i.e., feet, etc.). Divide the constant by the scale factor shown in the table. This number is then converted to 32-bit twos complement representation, as described in Appendix C.

The constants are stored in the program memory of the micro-computer. The program memory is organized into pages. Each page contains 256 lines. Each line is composed of two hexi-decimal digits – most significant digital (MSD) and least significant digit (LSD). The eight-digit constant will therefore require four lines. An example of

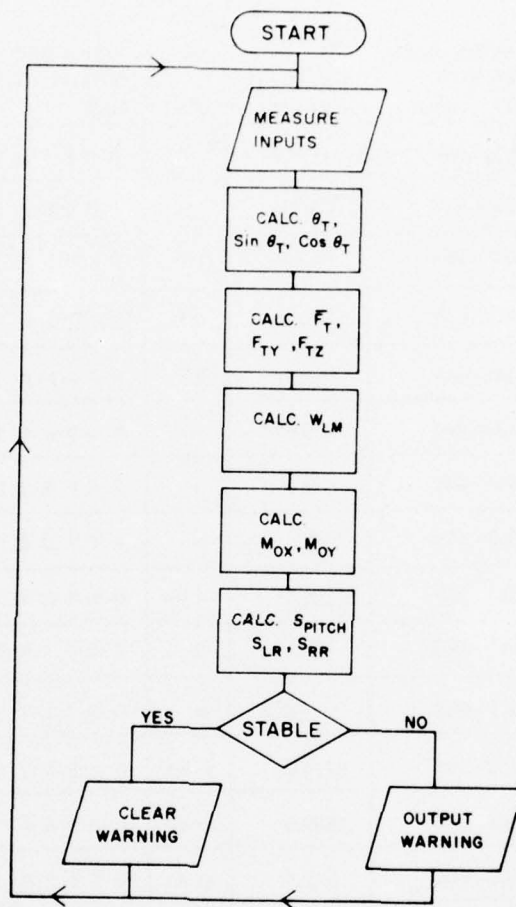

Fig 3-1. Program Flow Chart.

TABLE 3-1. PROGRAM CONSTANTS.

CONSTANT	MEMORY ADDR LOCATION		DECIMAL VALUE	UNITS	HEXA DECIMAL VALUE (Base 16)		SCALE FACTOR
	MSD	LSD			MSD	LSD	
A	637-634		.1461	-	F F F F D A 9 9		16 ⁻⁴
B	63B-638		1207.5	-	F B 4 8 7 F C C		16 ⁻⁴
C	63F-63C		677.07	-	0 2 A 5 1 1 9 C		16 ⁻⁴
A ₁	643-640		10.8	in ²	0 0 0 0 0 A C D		16 ⁻²
A ₂	647-644		12.57	in ²	F F F F F 3 6 E		16 ⁻²
A _L	64B-648		9.62	in ²	0 0 0 0 0 9 9 E		16 ⁻²
-(Z _T -Z _m)	64F-64C		-2.0	ft	F F F E 0 0 0 0		16 ⁻⁴
(-y _T)	653-650		-2.5	ft	F F F D 8 0 0 0		16 ⁻⁴
-(W _v y _v)	657-654		18,755.0	ft-lbs	0 0 4 9 4 3 0 0		16 ⁻²
W _{ms}	65B-658		780.0	lb	0 0 0 3 0 C 0 0		16 ⁻²
X _m /2	65F-65C		.677	ft	0 0 0 0 0 A D 5		16 ⁻³
W _v X _v	663-660		9274.0	ft-lbs	0 0 2 4 3 A 0 0		16 ⁻²
m ₁	667-664		2560.0	ft-lbs	0 0 0 A 0 0 0 0		16 ⁻²
m _{2R}	66B-668		512.0	ft-lbs	0 0 0 2 0 0 0 0		16 ⁻²
λ _{LRX}	66F-66C		0.36	-	0 0 0 0 0 5 C 2		16 ⁻³
λ _{LRY}	673-670		.945	-	F F F F F 0 E 2		16 ⁻³
λ _{RRX}	677-674		.36	-	F F F F F A 3 E		16 ⁻³
x _{R2}	67B-678		2.56	-	0 0 0 0 2 8 F 5		16 ⁻³
X _{R2} (w _v +w _{ms})	67F-67C		17,927.0	ft-lbs	0 0 4 6 0 7 0 0		16 ⁻²
m _{2L}	683-680		512.0	ft-lbs	F F F E 0 0 0 0		16 ⁻²

a stored constant is shown in Fig. 3-2. All constants are stored in page 6. (Refer to program memory assembly drawing 100971.) In order to alter a constant, the EPROM for page 6 will have to be erased and reprogrammed as previously described. Note that erasing the EPROM (Type 1702A) will destroy all of the information on that page. The page with the constants (page 6) also contains other information. Therefore, the proper procedure for altering vehicle parameters is to change only program locations which must be altered, and the remainder should be programmed as specified on the program listing (Appendix B).

CONSTANT = 01234567₁₆

Line #624₁₆
MSD LSD

7	6
---	---

Line #625₁₆
MSD LSD

5	4
---	---

Line #626₁₆
MSD LSD

3	2
---	---

Line #627₁₆
MSD LSD

1	0
---	---

Fig. 3-2. Constant Storage.

CHAPTER IV

INSTALLATION AND OPERATION

The SES was designed to be installed on conventional counterbalanced warehouse lift trucks with an articulated rear axle. The system has no provisions for attachments such as side shift. Also, lift cylinders which power down are not considered.

The system is installed on the vehicle by first installing the transducers and then connecting the transducers to the Exploratory System. The Exploratory System is then connected to a power source. System calibration adjustments must then be performed.

INSTALLATION

The following transducers must be installed:

- Lift Cylinder Pressure (P_{Lift})
- Tilt Cylinder Rod-Side Pressure (P_1)
- Tilt Cylinder End-Side Pressure (P_2)
- Mast Angle (σ_m)
- Side Load Strain (M_{cp})

The pressure transducers should be installed into the appropriate lines. Caution must be taken in order to insure that transducers are installed in the system to measure the pressure in the appropriate chambers in these cylinders.

The mast angle transducer should be installed on the mast, as shown in Drawing FPRC-LSM-8. This will typically require welding a bracket onto the mast to allow for mounting the angle transducer assembly, as shown in Drawing FPRC-LSM-10.

The side load strain is measured via conventional strain gauges attached to either side of the mast assembly. With the mast vertical, the gauges are installed on the outermost portion of the stationary portion of the mast, oriented vertically. Drawing FPRC-LSM-9 shows the location of the gauge on one side of the mast. The other gauge is installed on the opposite side of the mast assembly on the other upright. Temperature compensating gauges are mounted on steel blocks and installed near the sensing gauges. Figure 4-1 shows the electrical interconnection of the gauges.

Table 4-1 lists the wiring connection required to connect the transducers to the Exploratory System. The Exploratory System should be connected to a 12 VDC \pm VDC power source capable of supplying 3 amps. This connection is as follows:

\pm 12 VDC	J1-A	(white)
Ground	J1-B	(black)

CALIBRATION

The calibration of the analog circuitry is as follows:

1. Lower the carriage to the lowest position with the mast vertical. With the engine not operating, release the pressure in the hydraulic cylinders by cycling both the tilt and lift levers.
2. Apply power to the SES. Measure the voltage from Pin 2 to Pin 1 of the angle sensor. Rotate the sensor to obtain 1.67 VDC.

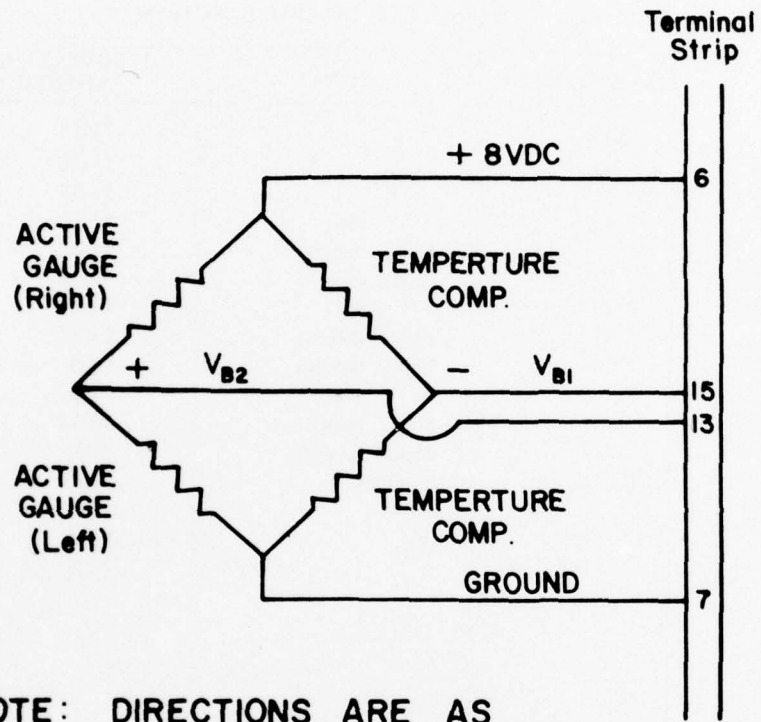

NOTE: DIRECTIONS ARE AS VIEWED BY THE OPERATOR.

Fig. 4-1. Strain Gauge Interconnection.

TABLE 4-1. TRANSDUCER INTERCONNECTION.

TRANSDUCER	SIGNAL	TERMINAL STRIP LOCATION
Angle	1	T1-17
	2	T1-20
	3	T1-15
P_{Lift}	+ V_{cc} (red)	T1-11
	Cond. (black)	T1-12
	Signal (green)	T1-10
P_1	+ V_{cc} (red)	T1-11
	Cond. (black)	T1-12
	Signal (green)	T1-8
P_2	+ V_{cc} (red)	T1-11
	Cond. (black)	T1-12
	Signal (green)	T1-9
Strain	+ 8VDC	T1-6
	GND	T1-7
	V_{B1}	T1-5
	V_{B2}	T1-4

3. Remove the front panel from the SES. With power removed from the system, install Card A9 onto the card extender into the A9 location. Apply power to the system. Adjust P4 for 5.0 VDC output from Amplifier A4 (Pin 55 on edge connector) measured with respect to ground (Pin 3 on edge connector).
4. Connect a voltmeter across the following pins. Adjust the potentiometer shown in order to obtain a voltage of 0.0 VDC.

from (+)	to (-)	adjust
Pin 19	Pin 3	P1
Pin 29	Pin 3	P2
Pin 39	Pin 3	P3

Remove this card from the extender and install into proper location.

5. Install A19 on the extender into the A19 location. Adjust P3 on the A19 card for 0.0 VDC at the output of A1 measured with respect to ground (Pin 3). Adjust P1 for 5.0 volts output from A2. Raise the forks to 10.0 ft. measured from the pivot point of the mast assembly to the bottom of the forks. Apply 100 lbs. side load to the forks. This force should be parallel to a line which is normal to both uprights and directed to the right as viewed by the operator. This is shown in Fig. 42. Adjust P2 for a reading of 0003E800 on Channel 7 on the portable readout. (NOTE: If the reading is greater than 80000000, then interchange the two signal leads on the strain gauge bridge and repeat this step of the procedure.)

USE OF THE PORTABLE READOUT

The portable readout is provided as a convenience for verifying operation of the system and for studying the relative stability of the vehicle. The information obtained

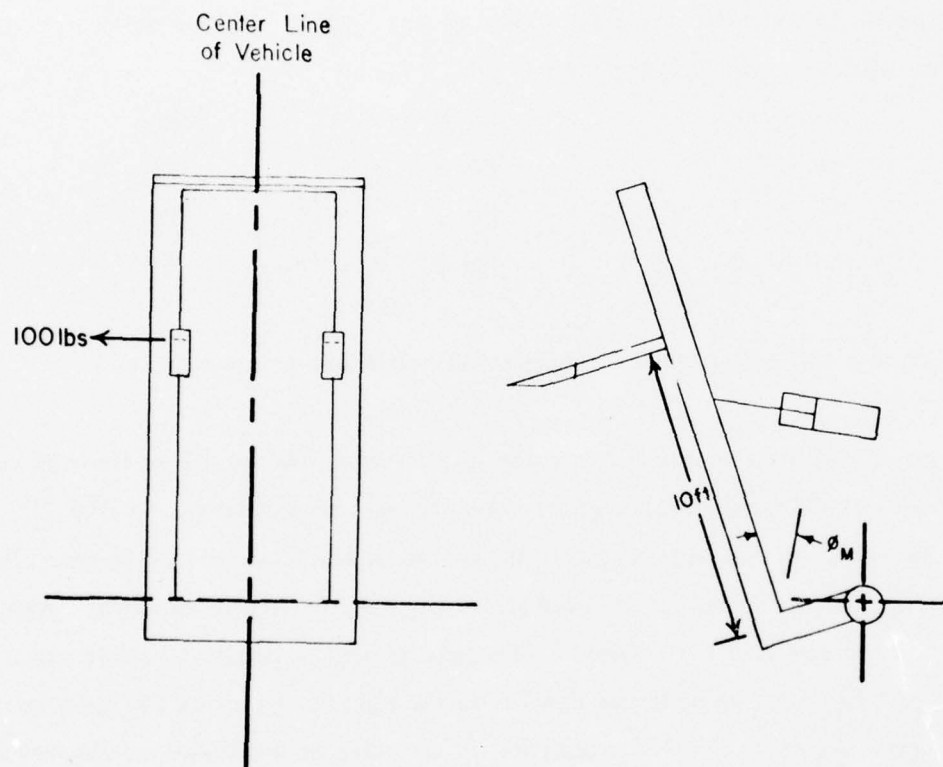

Fig. 4-2. Strain Gauge Calibration.

TABLE 42. PORTABLE READOUT PARAMETERS.

SWITCH VALUE	DATA OUTPUT	SCALE FACTOR
0	S_{pitch}	16^{-2}
1	mg	16^{-2}
2	S_{LR}	16^{-2}
3	S_{RR}	16^{-2}
4	$\sin \theta_T$	16^{-4}
5	$\cos \theta_T$	16^{-4}
6	W_{LM}	16^{-2}
7	M_{CPY}	16^{-2}
8	F_{TY}	16^{-2}
9	F_{T2}	16^{-2}

from this device is in the format of the computer, and appropriate conversions will have to be applied to this information.

The readout is connected to the system via a ribbon cable from the back of the computer to the lower connector on the readout. The readout channel is selected via the least significant thumbwheel decade. (The other connector and extra thumbwheel decade are not used.)

The parameters which are available for display are shown in Table 4-2. The information on the display is converted to decimal by first converting from twos complement notation to decimal. This number is then multiplied by the scale factor shown. (Refer to Appendix C.)

OPERATION

The system operation is straightforward. With power applied to the system, the alarm will sound whenever the SES calculates that the vehicle is becoming unstable. Two lights, one each for roll and pitch, provide a visual indication of an unstable configuration. This exploratory system is quite slow in performing the required calculations. The update time is approximately 2.2 seconds. The system is only capable of responding to statically caused instabilities. (NOTE: This is a limitation on the exploratory system and is not a fundamental limitation of the concept.)

CHAPTER V

TESTING PROGRAM

A testing program was devised to demonstrate the stability monitor utilizing the exploratory system installed on a conventional warehouse counterbalanced lift truck. These tests explore the viability of the concept in typical stacking operations. Only static operations on a horizontal plane have been considered in the design of the tests. Neither vehicle dynamics nor load dynamics were considered.

The testing program required the stability monitor to be demonstrated while being subjected to the following operations:

1. Lifting a load and moving the center of gravity to create a tipping condition.
2. Lifting of load in excess of the vehicle rated capacity.
3. Attempting to lift a load from elevated location including full mast height when the lift would create an unstable condition.
4. Attempting to lift a load positioned off-center on the vehicle forks.
5. With rated load on the forks, tilting the forklift mast forward and back at several different fork heights including full lift.

In order to insure safety of project personnel during these hazardous tests, a testing plan was devised which simulated the above conditions. The tests were designed to allow unstable operating regions to be entered in a controlled manner. In many cases, the instability could be held and allowed to establish equilibrium.

The test plan called for both applying external force loads to the vehicle's forks and for the vehicle to lift against dead loads. In order to accommodate this, a test bed was fabricated which allowed a cable to be attached to forks and routed down to the floor to

a pulley and then to the forks of another lift truck. This allowed a downward force to be applied to the vehicle's forks. The force applied could easily be varied by moving the support vehicle's forks or by a block and tackle setup. Whenever required to lift against a dead load, the pulley was removed and the cable attached directly to the test bed. A fixture was fabricated to allow these forces to be applied anywhere in the plane of the forks.

During all testing, the load force was measured with an in-line load cell. The values of S_{pitch} (which is equal to M_x), M_y , S_{LR} , and S_{RR} were recorded. The stability limits for these tests were as follows:

$$\begin{aligned} m_1 &= 2560 \text{ ft-lbs (pitch)} \\ m_{2R} &= 512 \text{ ft-lbs (right roll)} \\ m_{2L} &= 512 \text{ ft-lbs (left roll)} \end{aligned}$$

The following sections discuss each test. The five tests previously mentioned were performed. A sixth test was required in order to further validate the concept. An unstable configuration is defined as the complete removal of reactions from one or more points of support. The test condition nomenclature is defined in Fig. 5-1.

The tests were performed on an Eaton GLC-505B warehouse lift truck with cushion tires (5000 lbs). Parameters for the vehicle which were required by the program were obtained both by measurement and by engineering judgment. The large number of parameters required results in a large number of degrees of freedom when attempting to "fine tune" the calculations. Parameter values were used which tended to result in acceptable performance of the system. The important aspect of these tests is not to evaluate the absolute values obtained for \bar{S} but rather to observe trends. For the sake of comparison, the approximate values of \bar{S} in an unload configuration are as follows:

$$\begin{bmatrix} S_{pitch} \\ S_{LR} \\ S_{RR} \end{bmatrix} = \begin{bmatrix} 18,750 \\ 4,000 \\ 4,000 \end{bmatrix} \text{ ft-lbs}$$

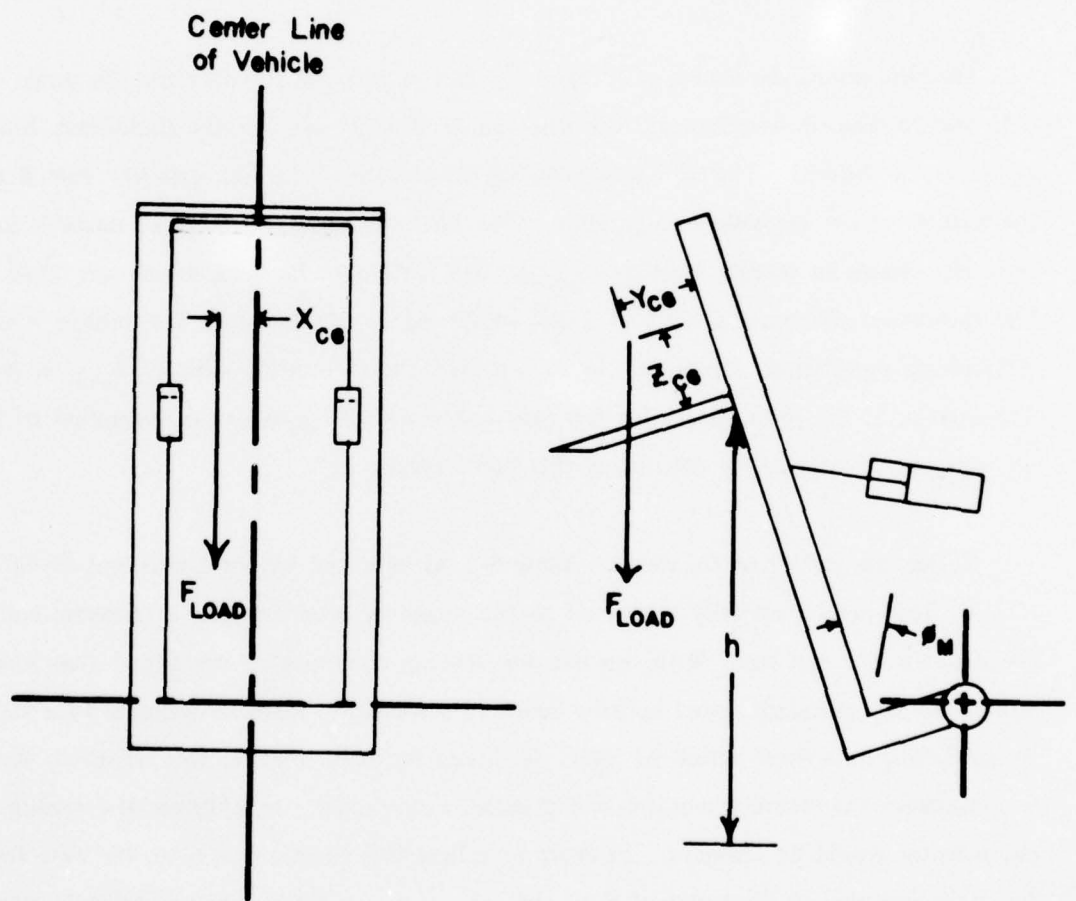

Fig. 5-1. Test Plan Nomenclature.

TEST 1

This test is to demonstrate "lifting a load and moving the center of gravity to create a tipping condition." This was accomplished by applying a load to the vehicle, which resulted in a stable configuration, and then applying the same loading at a different location, resulting in an unstable configuration, thus simulating the change in center of gravity.

The test results are shown in Table 5-1. Part A presents the data for the stable case. With this loading, it was observed that the vehicle stability was greatly diminished, but stable as previously defined. The SES was providing an unstable indication (pitch). Part B presents the results for the unstable configuration. The SES was again providing an unstable indication. Note the change in relative stability (S_{pitch}). The difference in mean values was 2739 ft-lbs. The theoretical difference is $(3 \text{ ft} - 2 \text{ ft}) \cdot 4720 \text{ lbs} = 4720 \text{ ft-lbs}$. The vehicle would establish an equilibrium condition. In such a case, the theoretical value of S_{pitch} is zero. The average of the mean values for the four test conditions provides an indication of the repeatability of reading for calculating this "zero condition."

Notice the scatter of the data in Table 5-2, as indicated by the coefficient of variance (C.V.). This can be partially attributed to the length of time required to measure and record the data for one test run. With this extreme loading condition, it was found that leakage within the tilt cylinders would actually result in a transition from an unstable to a stable configuration in a short period of time. It should be noted that, as this occurred, the warning from the stability monitor would cease, as expected. In addition, the reading from the monitor would be changing. In order to reflect this function of time, the data for a run were recorded in the order of S_{pitch} , M_y , S_{LR} , S_{RR} . The next run would be recorded in the reverse order. Although this was occurring on all of these runs, it was particularly dominant at the 10.0 ft. height. Note the trend in alternate runs.

TABLE 5-1. TEST 1 RESULTS - PART A.

Test Conditions: $x_{CG} = 0.0$; $y_{CG} = 2.0$ ft; $\theta_m = 5.4$; $F_L = 4720$ lbs

S_{pitch} (ft-lbs)	M_y (ft-lbs)	S_{LR} (ft-lbs)	S_{RR} (ft-lbs)
522*	16,861	15,563	26,760
1070	16,845	15,821	27,032
1141	16,909	15,588	26,948
1448	16,980	15,822	28,801
1282	17,185	15,490	24,292
706*	16,862	15,748	27,416
895*	16,994	15,896	27,241
642*	16,863	15,862	26,543
378*	16,818	15,491	26,562
883*	16,738	15,694	26,802
897	16,906	15,698	26,840
342	123	155	1,108
38.1	0.7	1.0	4.1

Mean (μ)

Standard Deviation (S)

Coefficient of Variance (C.V.)

*Unstable Indication (pitch)

Stability limit for pitch axis (m_1) = 1024 ft-lbs.

TABLE 5-1. TEST 1 RESULTS – PART B (Cont.).

Test Conditions: $X_{CG} = 0.0$; $y_{CG} = 3.0$ ft; $\theta_m = 5.40$; $F_L = 4720$ lbs.

	S_{pitch} (ft-lbs)	M_y (ft-lbs)	S_{LR} (ft-lbs)	S_{RR} (ft-lbs)
	-2023*	16,977	16,743	27,552
	-1837*	16,777	16,603	27,532
	-1932*	16,840	16,588	27,464
	-963*	16,975	16,581	27,767
	-2192*	16,767	18,646	27,481
	-1932*	16,687	16,563	27,714
	-1908*	16,713	16,433	27,126
	-1790*	16,586	16,347	27,281
	-1932*	16,630	16,253	26,645
	-1913*	16,592	16,383	27,505
μ	-1842	16,754	16,714	27,407
S	327	142	694	326
C.V.	17.8	0.85	4.15	1.2

*Unstable Indication (pitch).

TABLE 5-2. TESTS 2 AND 3 RESULTS.

Test Conditions: $X_{CG} = 0$; $y_{CG} = 2.0$ ft; $h = 4.0$ ft

	F_{LOAD} (lbs)	S_{pitch} (ft-lbs)	M_y (ft-lbs)	S_{RL} (ft-lbs)	S_{RR} (ft-lbs)
	6480	-1314	19,415	38,887	30,429
	6480	-737	19,184	10,441	34,904
	6440	-1160	19,352	38,847	30,372
	6440	-721	19,133	10,641	34,850
Mean	6460	-983	19,271	24,704	32,639
S.D.	23	300	134	16,354	2,585
C.V.	0.4	30.5	0.7	66.2	7.9

Test 2

$h = 6.0$ ft

	F_{LOAD} (lbs)	S_{pitch} (ft-lbs)	M_y (ft-lbs)	S_{RL} (ft-lbs)	S_{RR} (ft-lbs)
	6400	-865	18,713	38,333	31,105
	6400	-700	18,529	38,345	31,332
	6400	-1105	18,657	38,343	30,769
	6400	-1037	18,710	37,235	36,882
Mean	6400	-927	18,652	38,064	30,022
S.D.	0	182	86	575	2,106
	0	19.6	0.5	1.5	7.0

Test 3

TABLE 5-2. TESTS 2 AND 3 RESULTS (Cont.)

h = 8.0 ft

	F _{LOAD} (lbs)	S _{pitch} (ft-lbs)	M _y (ft-lbs)	S _{RL} (ft-lbs)	S _{RR} (ft-lbs)
	6480	-1433	19,054	39,750	31,421
	6480	-1254	19,163	18,796	33,696
	6480	-1318	19,603	38,948	30,840
	6400	-1133	19,053	18,652	35,017
Mean	6460	-1285	19,218	29,037	32,744
S.D.	40	125	262	11,912	1,953
C.V.	0.6	9.7	1.4	41	6.0

h = 10.0 ft

Test 3

	F _{LOAD} (lbs)	S _{pitch} (ft-lbs)	M _y (ft-lbs)	S _{RL} (ft-lbs)	S _{RR} (ft-lbs)
	6440	-1425	19,877	38,800	30,493
	6440	- 864	18,735	1,686	33,188
	6400	-1912	18,577	38,239	29,587
	6400	- 777	18,794	1,655	35,499
Mean	6420	-1245	18,996	20,095	32,192
S.D.	23	530	595	21,276	2,683
C.V.	0.4	42.6	3.1	106	8.3

Statistics for Both Tests

Mean	6437	-1110	19,034	29,975	31,899
S.D.	35	332	390	14,810	2,393
C.V.	0.5	29.9	2.1	52.9	7.5

6435	-1098	19,034	27,975	31,899
30	192	281	7,653	1,274
0.5	17.5	1.5	27.4	4.0

Avg. of Means
S.D. of Means
C.V. of Means

TEST 4

The purpose of Test 4 was to "attempt to lift a load positioned off-center on the vehicle forks." This was accomplished by attaching a chain from a dead weight to one fork. The point of attachment was three feet from the face of the fork. This resulted in a loading which was off-center with respect to the center line of the vehicle and off-center with respect to the "standard" longitudinal load center distance ($y_{CG} = 2$ ft) used for rating vehicle capacities. A lift was attempted until the vehicle became unstable either longitudinally or laterally. In this extreme loading condition, large deformations were occurring in both the fork and the mast. Forces which were not normal to the plane of the forks at times caused rotation (yaw) of the vehicle. In each case, this loading resulted in a longitudinal instability.

The data for this test are contained in Table 5-3. It should be noted that the pressure bleed-off in the tilt cylinder discussed in the previous test was occurring during this test, making interruption of the data difficult. Further investigation revealed that, though initially S_{pitch} was consistently less than 1,000 ft-lbs, the loading involved caused the vehicle to seek an equilibrium. It was found that S_{pitch} had substantially changed, even when the vehicle remained unstable. It is theorized that this is attributed to the failure of the vehicle in this extreme loading condition to behave as idealized in the model development.

Severe twisting (yaw) of the mast assembly is the most probable cause of these discrepancies.

TABLE 5-3. TEST 4 RESULTS.

Test Conditions: $\theta_m = 0$; X_{CG} Right Fork; $y_{CG} = 3.0$ ft

h = 6.0 ft.

	F_{LOAD} (lbs)	S_{pitch} (ft-lbs)	M_y (ft-lbs)	S_{LR} (ft-lbs)	S_{RR} (ft-lbs)
	5760	2161	29,504	26,522	52,468
	5760	3284	28,494	26,977	52,777
	5760	1784	28,862	25,665	44,969
	5760	3534	28,234	26,493	53,173
Mean	5760	2691	28,774	26,414	50,847
S.D.	0	850	851	546	3,929
C.V.	0	31.5	1.9	2.1	7.7

h = 8.0 ft.

	F_{LOAD} (lbs)	S_{pitch} (ft-lbs)	M_y (ft-lbs)	S_{LR} (ft-lbs)	S_{RR} (ft-lbs)
	5640	1800	32,254	27,119	45,457
	5600	2788	27,957	26,158	53,019
	5520	898	27,708	25,984	40,080
	5480	2346	27,233	25,667	48,065
Mean	5560	1958	28,788	26,232	46,655
S.D.	73	814	2,330	625	5,390
C.V.	1.3	41.6	8.1	2.4	11.6

TABLE 5-3. TEST 4 RESULTS (Cont.)

	F_{LOAD} (lbs)	S_{pitch} (ft-lbs)	M_y (ft-lbs)	S_{LR} (ft-lbs)	S_{RR} (ft-lbs)
	5600	818	28,124	25,791	41,851
	5560	2517	27,735	26,230	57,305
	5560	880	28,977	25,929	43,890
	5560	1753	27,404	26,451	42,944
Mean	5570	1725	28,066	26,100	46,498
S.D.	20	790	678	297	7,253
C.V.	0.4	45.8	2.4	1.1	15.6

Mean	5630	2043	28,541	26,249	48,000
S.D.	104	906	1,347	480	5,559
C.V.	1.9	44.3	4.7	1.8	11.6

TEST 5

The purpose of this test was to demonstrate operation of the vehicle "with rated load on the forks, tilting the forklift mast forward and back at several different fork heights, including full lift." This was implemented by applying a 5000 lbs. load to the forks at heights of 6, 8, and 10 ft. and mast angles of 0, +5°, and -10°. This test demonstrated that the SES is indeed sensitive to both mast height and angle. The results of this test are shown in Table 5-4.

TEST 6

This test was devised to demonstrate that the SES can detect instability about the roll axes. A side load was applied to the forks at several heights. In each case, a load sufficient to raise one front tire was applied. Table 5-5 presents the data for this test. In each case, the SES determined the correct indication.

TEST CONCLUSIONS

These tests substantiate the validity of the methodology proposed. In every test, the SES was providing an unstable indication when the vehicle was unstable. In Test 1 (Part A), the vehicle stability was certainly *marginal*, and the SES was providing an unstable indication. This is considered to be highly desirable. The device should be sufficiently conservative to warn the operator prior to encountering an unstable configuration. The relative stability (\bar{S}) was found to behave as predicted. These calculations reveal acceptable repeatability in all tests except one (Test 4). In this test, S_{pitch} unexpectedly was found to deviate on an individual test run. The value of S_{pitch} was not found to be comparable to the other test, which resulted in longitudinal instabilities. This test was such an extreme loading condition that it is not believed to be a normally encountered loading condition.

TABLE 5-4. TEST 5 RESULTS.

$\theta_m = 0^\circ$; h = 10 ft.

	LOAD (lbs)	S_x (ft-lbs)	M_y (ft-lbs)	S_{LR} (ft-lbs)	S_{RR} (ft-lbs)
	5000	2763	17,679	15,487	26,168
	5000	2909	17,535	15,394	26,223
	5000	2836	17,596	15,507	26,296
μ	5000	2836	17,603	15,463	26,168
S	0	73	72	60	64
C.V.	0	2.57	0.4	0.4	0.2

$\theta_m = 0^\circ$; h = 8 ft.

	5000	3224	17,439	15,225	25,972
	5000	3153	17,512	15,319	26,014
	5000	3827	18,314	15,868	23,969
μ	5000	3435	17,755	15,471	25,318
S	0	350	485	347	1,169
C.V.	0	10.2	2.7	2.2	4.6

$\theta_m = 0^\circ$; h = 6 ft.

	5000	3074	17,357	15,340	25,817
	5000	3104	17,422	15,275	25,722
	5000	3153	17,320	15,019	25,887
μ	5000	3110	17,365	15,211	25,809
S	0	40	52	170	83
C.V.	0	1.3	0.3	1.1	0.3

$\theta_m = 5^\circ$; h = 10 ft.

	5000	522*	17,075	15,775	27,605
	5000	1189*	17,174	15,607	25,896
	5000	-275*	17,049	16,006	27,949
μ	5000	479	17,099	15,796	27,150
S	0	733	66	200	1,100
C.V.	0	153	0.4	1.3	4.1

*Stability Warning (pitch)

TABLE 5-4. TEST 5 RESULTS (Cont.).

$\theta_m = +5^\circ$; h = 8 ft.

	5000	516*	17,437	16,164	37,368
	5000	859*	17,501	16,054	25,460
	5000	- 6*	17,391	16,418	27,641
μ	5000	456	17,443	16,417	26,139
S	0	436	55	140	224
C.V.	0	95.6	0.3	0.9	0.9

$\theta_m = +5^\circ$; h = 6 ft.

	5000	883*	17,753	16,275	26,128
	5000	611*	17,993	16,555	26,369
	5000	859*	19,617	16,422	25,921
μ	5000	784	18,454	16,417	26,139
S	0	151	1,014	140	224
C.V.	0	19.3	5.5	0.9	0.9

$\theta_m = -10^\circ$; h = 10 ft.

	5000	7255	15,986	12,408	24,549
	5000	6974	16,288	13,053	25,024
	5000	6833	16,277	13,031	25,566
μ	5000	7021	16,184	12,831	25,046
S	0	215	171	366	509
C.V.	0	3.1	1.1	2.9	2.0

$\theta_m = -10^\circ$; h = 8 ft.

	5000	6948	16,914	13,398	25,382
	5000	6769	16,848	13,402	25,115
	5000	6718	16,869	13,443	25,456
μ	5000	6812	16,877	13,414	25,318
S	0	121	34	25	179
C.V.	0	1.8	0.2	0.2	0.8

TABLE 5.4. TEST 5 RESULTS (Cont.).

$\theta_m = -10^\circ$; $h = 6$ ft.

	5000	406	17,122	13,785	25,404
	5000	421	17,027	13,659	25,412
	5000	424	16,973	13,682	25,218
μ	5000	417	17,041	13,709	25,345
S	0	10	75	67	110
C.V.	0	2.4	0.4	0.5	0.4

TABLE 5.5. TEST 6 RESULTS.

$h = 10$ ft; $\theta_m = 0^\circ$

	LOAD (lbs)	LOAD MOMENT (ft-lbs)	S_x (ft-lbs)	M_y (ft-lbs)	S_{LR} (ft-lbs)	S_{RR} (ft-lbs)
	304	3040	18,151	5721	- 56	7952
	312	3120	18,125	5654	- 24	8205
	316	3160	18,151	5636	-0.75	7837
	318	3180	18,100	6903	- 9	8018
μ	312	3125	18,132	5979	- 22	8003
S	6	62	24	617	24	154
C.V.	1.9	2	0.1	10.3	109	1.9

$h = 8$ ft.

	426	3408	18,125	6761	124	7756
	421	3368	18,050	6762	96	7869
	412	3296	18,075	6811	79	7732
	412	3296	18,075	6814	86	7716
μ	418	3342	18,081	6787	96	7768
S	7	55.6	31	29	20	69
C.V.	1.7	0	0.2	0.4	20.8	0.9

$h = 6$ ft.

	592	3552	17,765	7276	-446	7437
	572	3432	17,761	7278	-426	7402
	564	3384	17,886	7310	-457	7309
	580	3480	17,837	7312	-448	7405
μ	577	3462	17,812	7294	444	7388
S	12	72	60	20	13	55
C.V.	2.1	2	0.3	0.3	2.9	0.7

CHAPTER VI

SUMMARY, CONCLUSIONS & RECOMMENDATIONS

Phase I of this study derived a mathematical foundation which provided a logical basis for the development of a stability monitor/controller for MHE. This was used in considering various approaches for the evaluation of vehicular stability. It was found that the paramount problem is one of measurement. It is first necessary to determine parameters which can be measured on a conventional vehicle to provide sufficient information about the vehicle's stability. It is then necessary to evaluate the viability of obtaining transducers which will be reliable, rugged, and low-cost. This study found that the vehicle stability can indeed be determined by utilizing appropriate models for the vehicle. This in conjunction with auxiliary parameters which are readily measured can be used to determine vehicular stability.

The approach derived does not require special provisions for systems with options such as side shift. The parameter selected will reflect load disturbances. This approach does rely on utilizing the hydraulic cylinders to provide force-related measurements. Vehicles with cylinders which can rest against mechanical stops can determine erroneous information. Cylinders with hydraulic stops or some other means of determining the forces must be used.

Phase II of this study designed, fabricated, and tested a stability monitor. This system considered static configurations on a level surface. Although this system was suboptimal from a production standpoint, it did serve to demonstrate that a stability monitor is feasible.

This study proposes two types of control – an operator-augmented control and a diminished-operator control system. The first system provides feedback to the operator for his evaluation of needed corrective action. This system is actually a stability monitor but, when the operator is included, constitutes a control system. The second system proposed inhibits the operator from continuing to operate in a region of poor vehicle stability. Neither

of these provides corrective control. The consequences of an automatic control system attempting to apply corrective actions to the vehicle (such as moving the mast) are unacceptable.

It is recommended that further investigations be performed in order to evaluate the proposed method in dynamic situations. The optimal approach for incorporating dynamics should be determined. Potential candidates include conservative static systems, monitor accelerations, monitor-related vehicle parameters (such as throttle position), and monitor rate of change of \bar{S} . Extensive simulations should be performed in order to evaluate the suitability.

Upon determining the optimal approach for the incorporation of dynamics, the hardware should be refined. The present state of the art allows for a compact unit which could easily be produced. The present micro-computers provide ample computational capabilities. Suitable transducers are presently developed (or being developed) such that the system could readily be maintained by field personnel.

REFERENCES

1. "*PROM User's Guide*," Pro-Log Corporation, Monterey, California, 1977.

APPENDIX A

The following drawings are the hardware documentation for the MHE Vehicle Stability/Safety Exploratory System (SES).

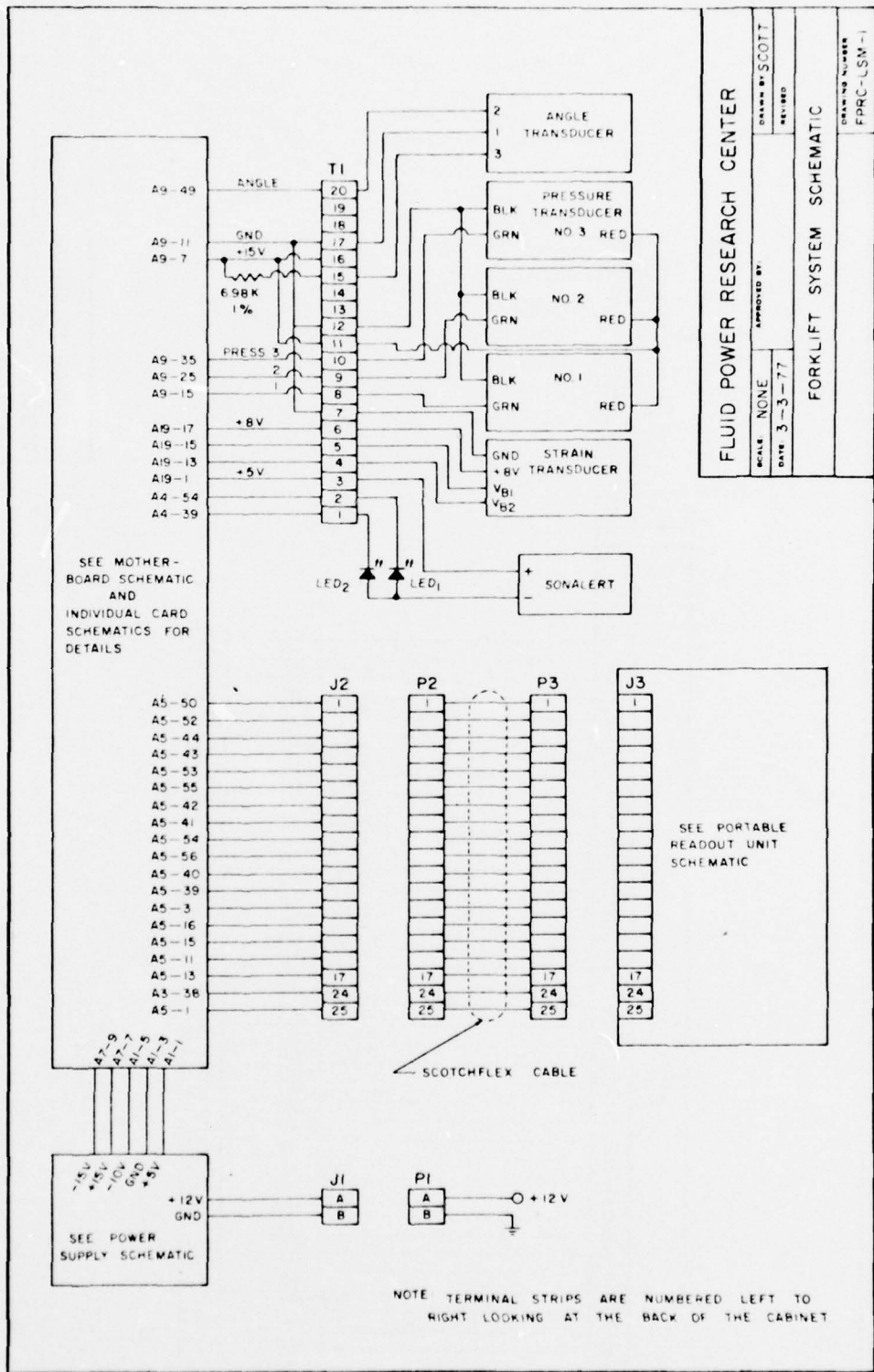

PRECEDING PAGE BLANK NOT FILMED

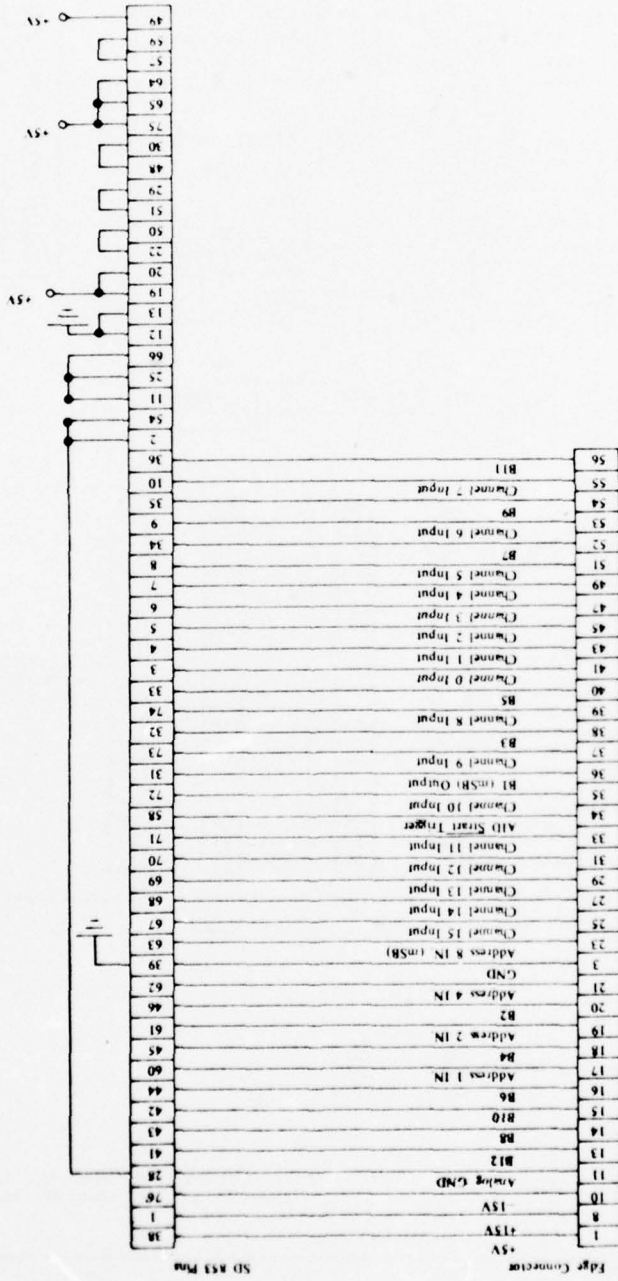

ANALOG TO DIGITAL CONVERTER SCHEMATIC

SCALE FULL	DRAWN BY: M. SLOAN	APPROVED BY:
DATE: 7 JAN 77	REVISED:	
FLUID POWER RESEARCH CENTER		
BURR-BROWN SDM 853		
<small>DATE: 10/11/77 DRAWN BY: M. SLOAN REVISED: FPRC-LSM-2</small>		

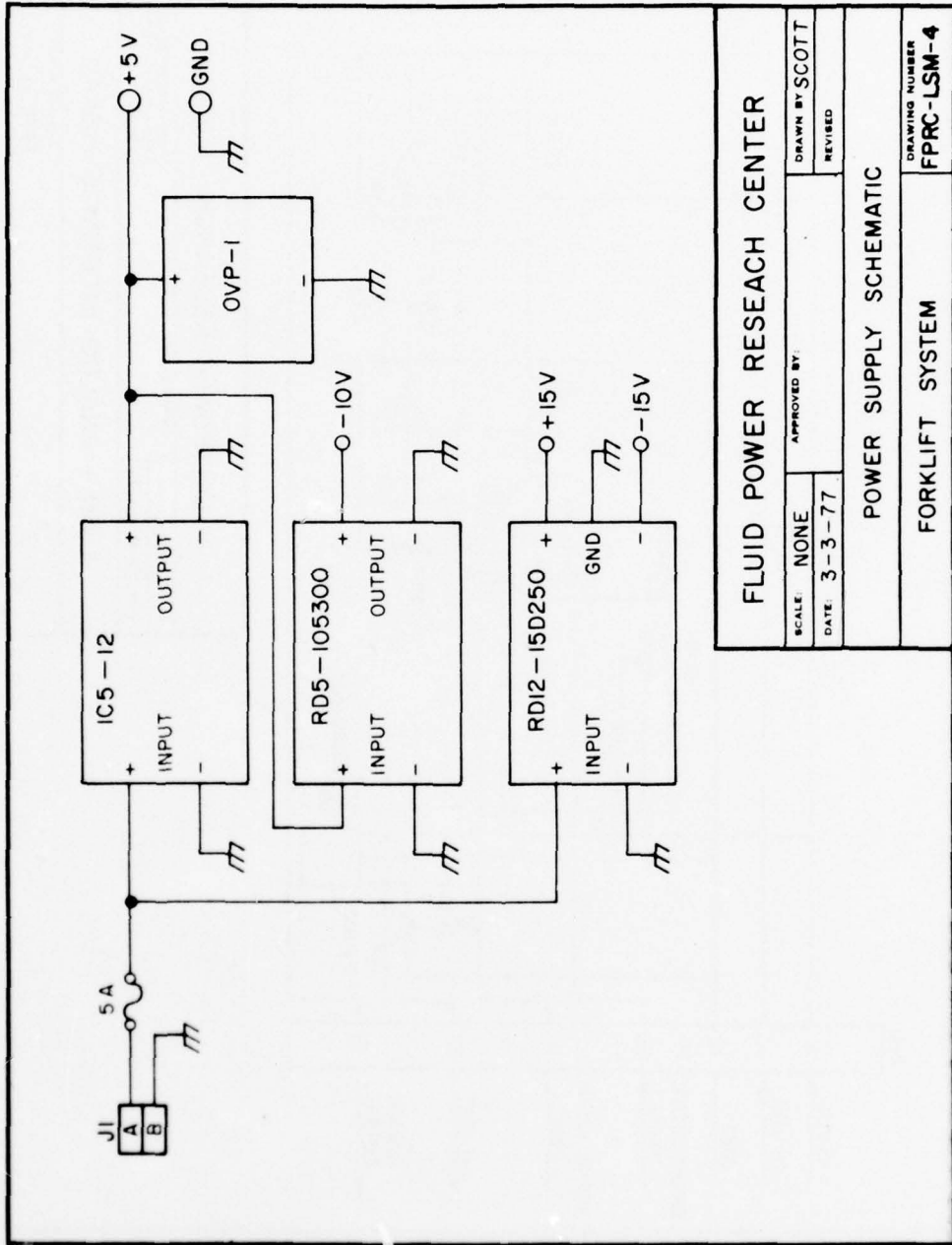

FLUID POWER RESEARCH CENTER	
SCALE: NONE	APPROVED BY:
DATE: 3-3-77	DRAWN BY: SCOTT
POWER SUPPLY SCHEMATIC	
DRAWING NUMBER	
FPRC-LSM-4	
FORKLIFT SYSTEM	

8 N 311 PRINTED ON 80 LEMON CLEARPRINT

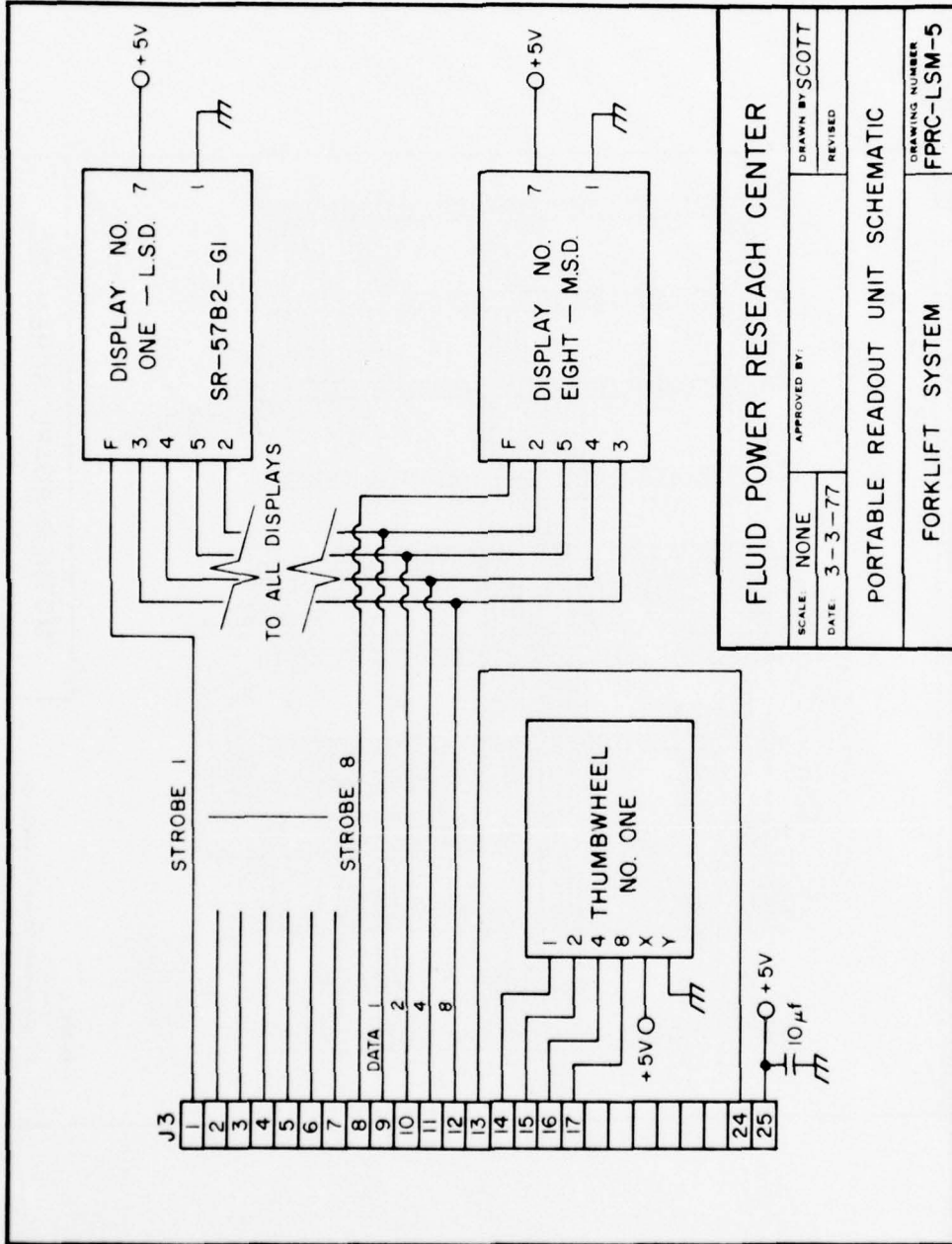

FLUID POWER RESEARCH CENTER	
SCALE NONE	APPROVED BY:
DATE 3-3-77	DRAWN BY SCOTT
	REVISED
PORTABLE READOUT UNIT SCHEMATIC	
DRAWING NUMBER	
FPRC-LSM-5	

8/12/77 PRINTED ON NO. 1000M CLEARPRINT

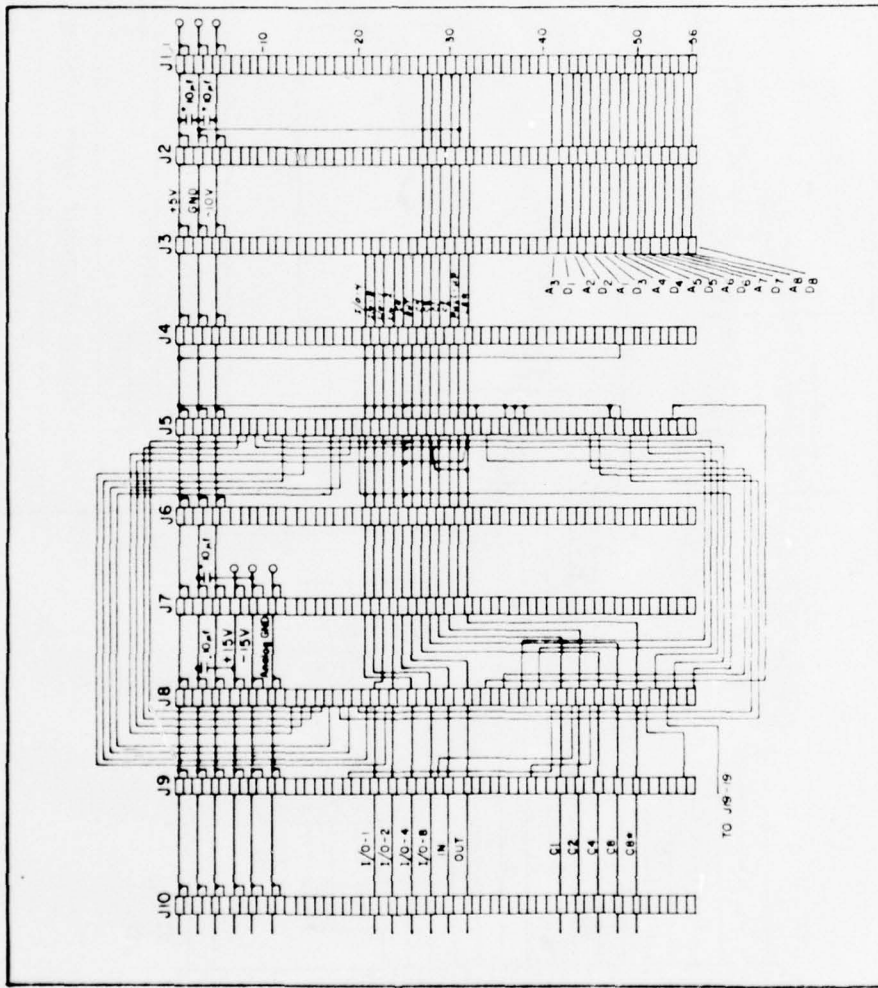

NOTES:

1. J11 through J21 are the same as J10
2. Does not include connections external to mother board; see system schematic.

MOTHER BOARD SCHEMATIC	
DATE: 9 DEC 76	DWG BY: R. Sloan
FLUID POWER RESEARCH CENTER	
FPRC-LSM-6	

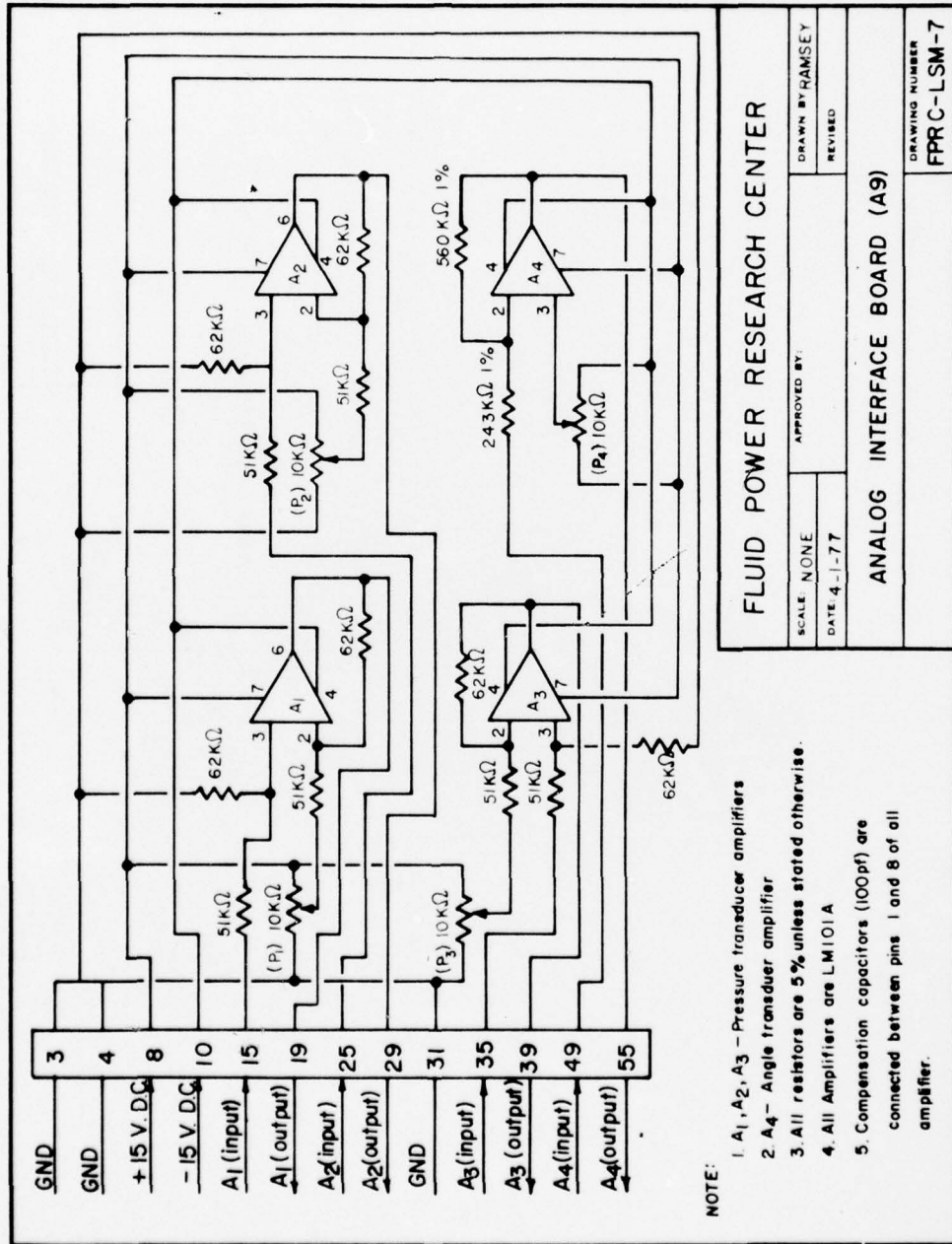

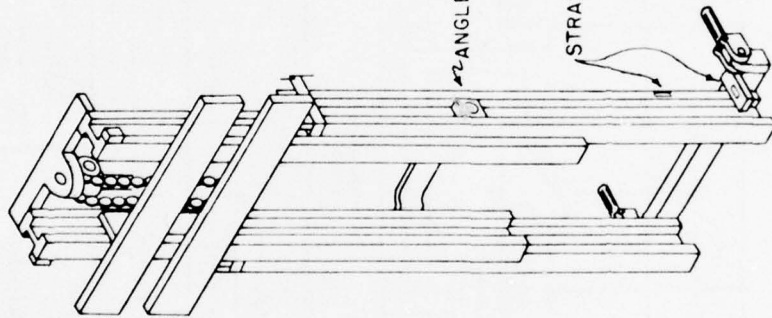

SCALE 3/4" = 1"	APPROVED BY	DESIGNED BY R. SLOAN
DATE NOV 1976	REV. NO.	REV. NO.
FLUID POWER RESEARCH CENTER		
DRAWING NUMBER		
FPRC-LSM-8		

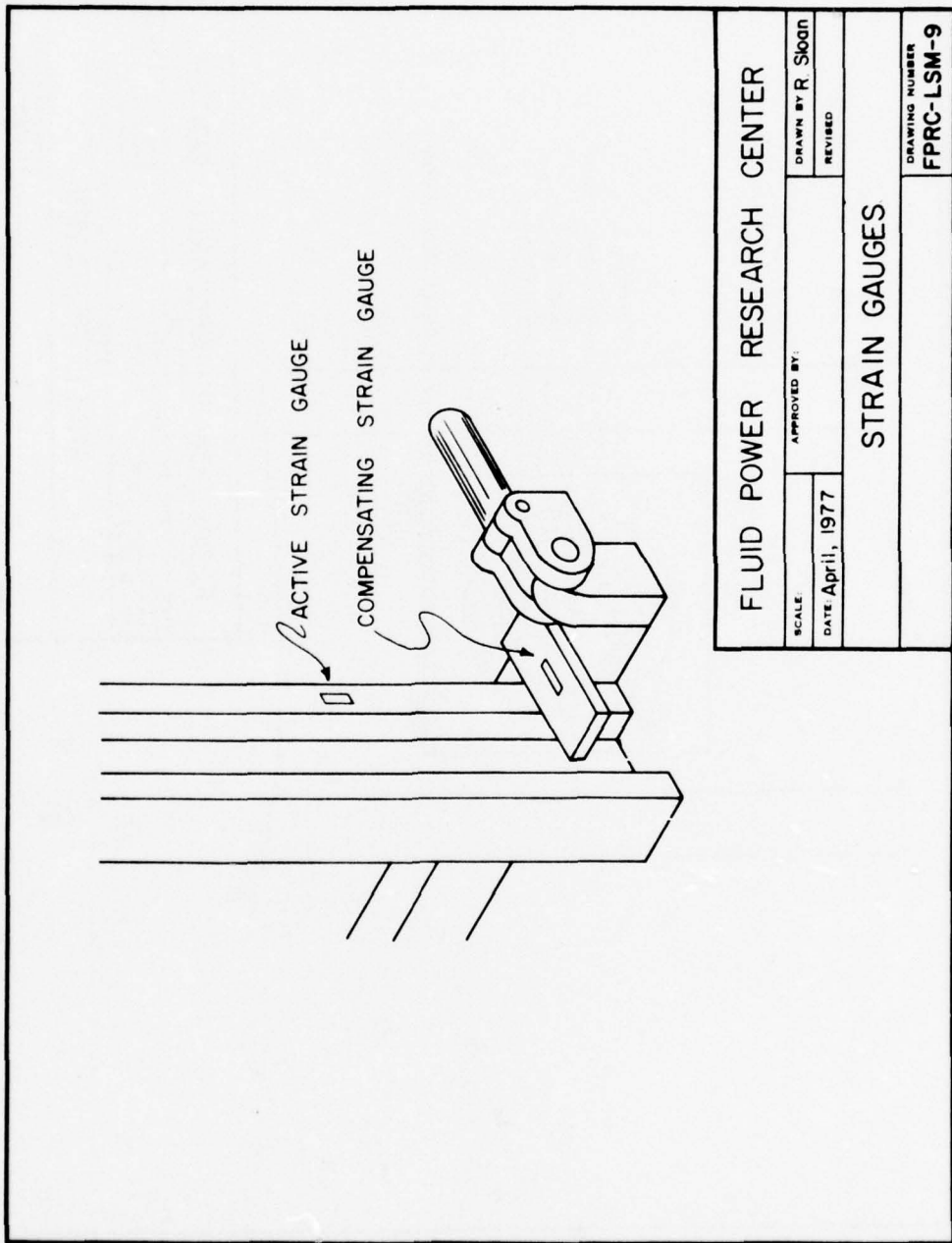

94,511 PRINTED ON NO. 1000 CLEARPRINT

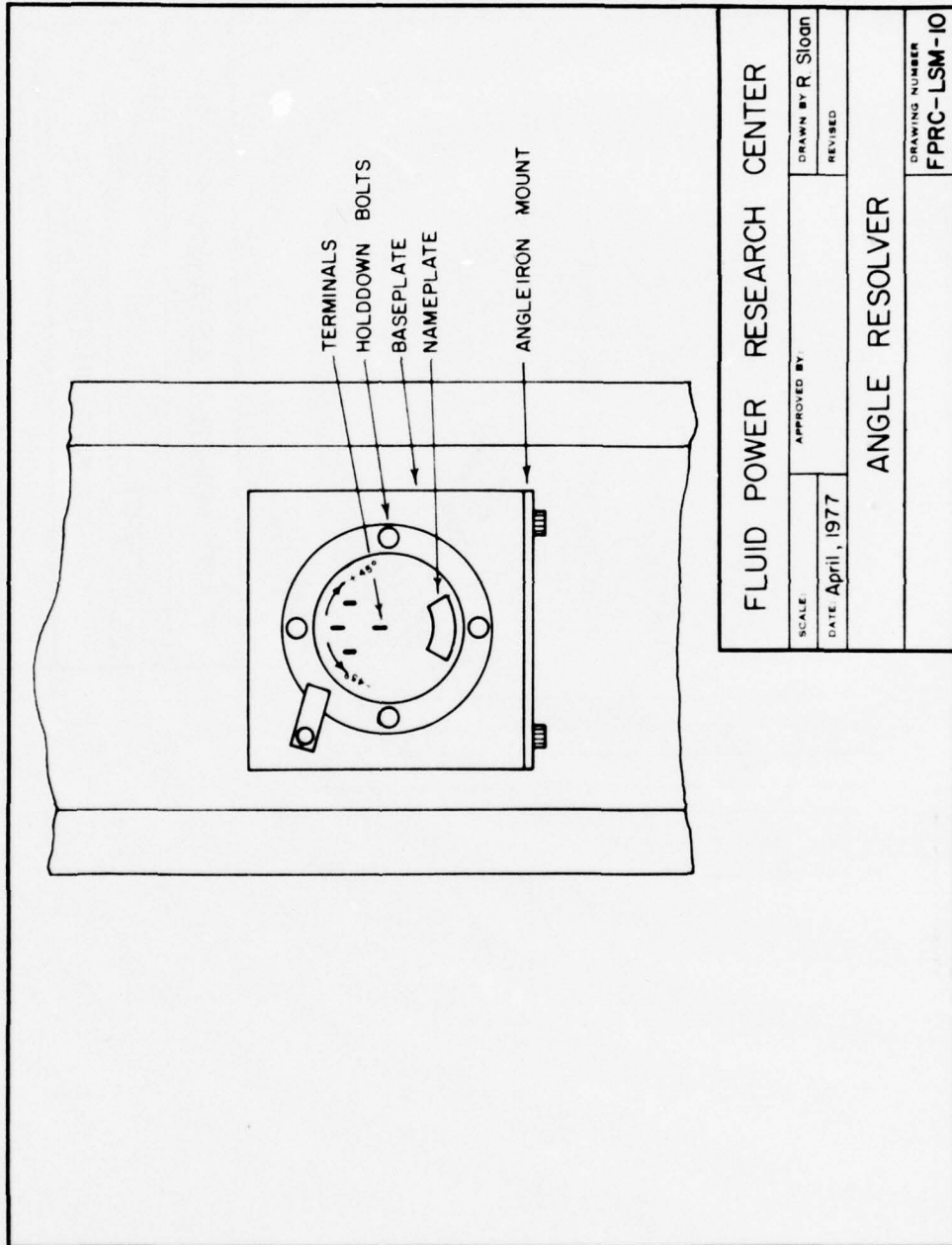

FLUID POWER RESEARCH CENTER		APPROVED BY:	DRAWN BY R. SIOGIN
		SCALE:	REVISED:
		DATE April, 1977	
ANGLE RESOLVER			
DRAWING NUMBER			FPRC-LSM-10

8 1/2" X 11" PRINTED ON NO. 1000H CLEARPRINT

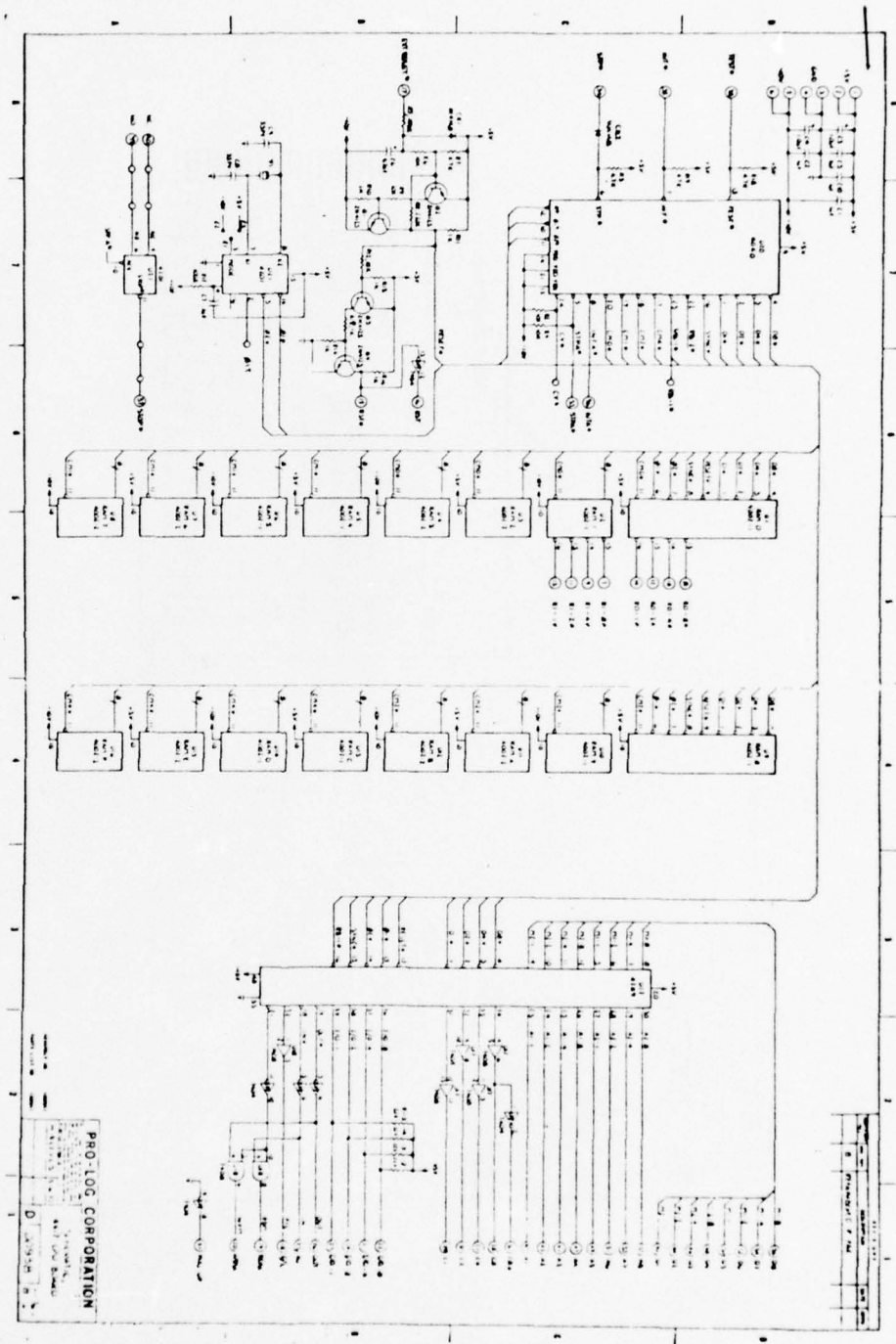

BEST AVAILABLE COPY

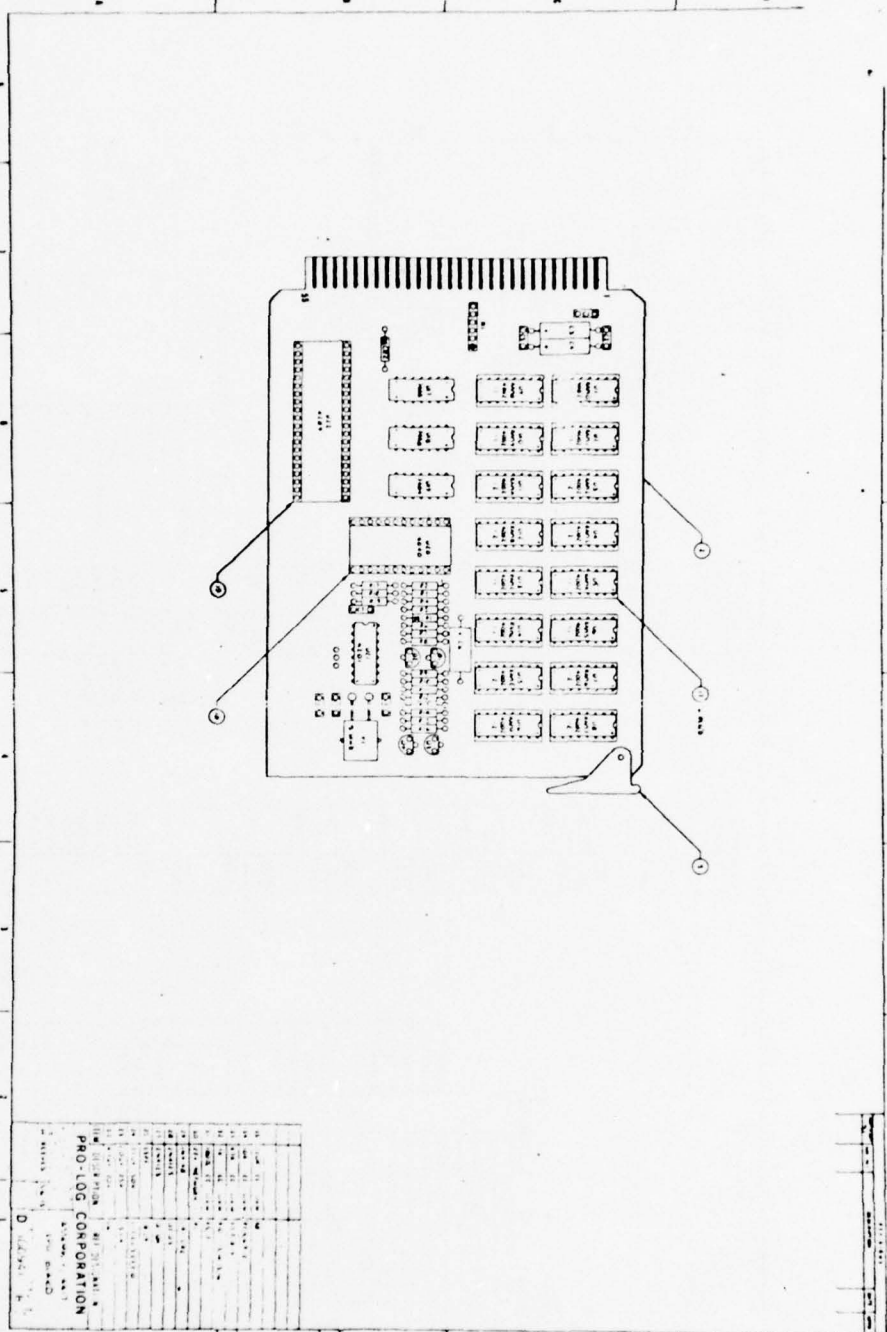

BEST AVAILABLE COPY

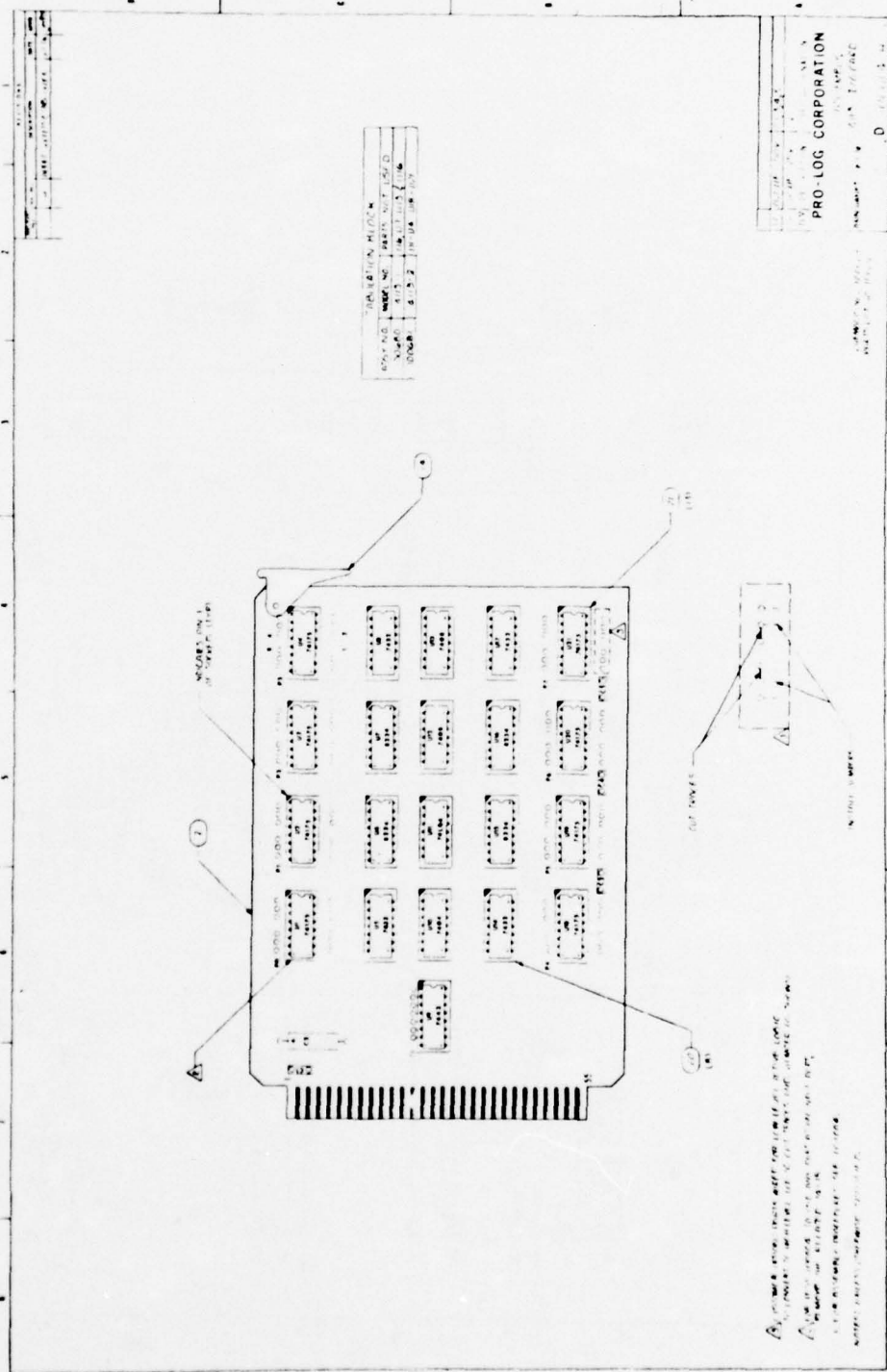

BEST AVAILABLE COPY

BEST AVAILABLE COPY

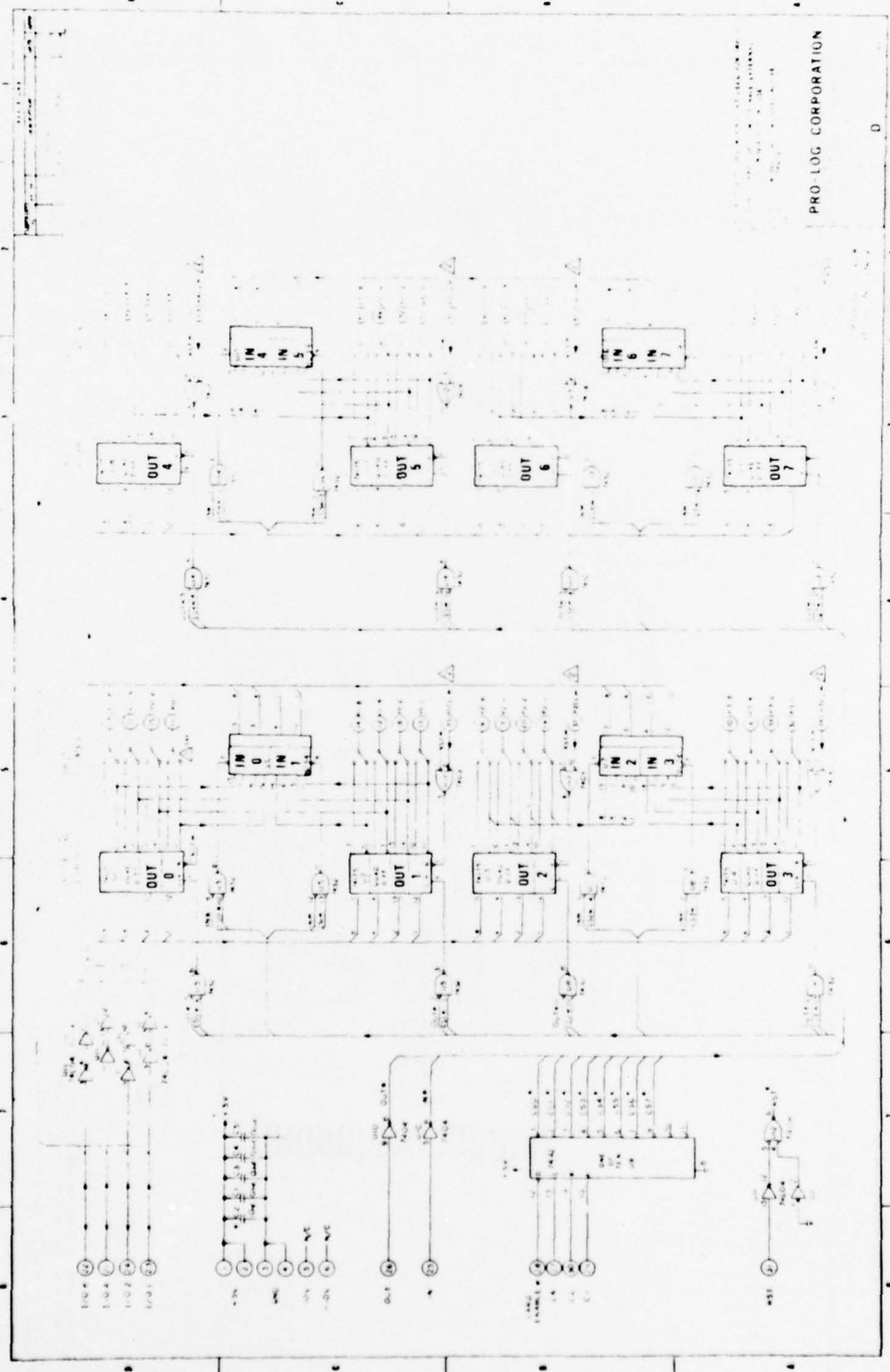

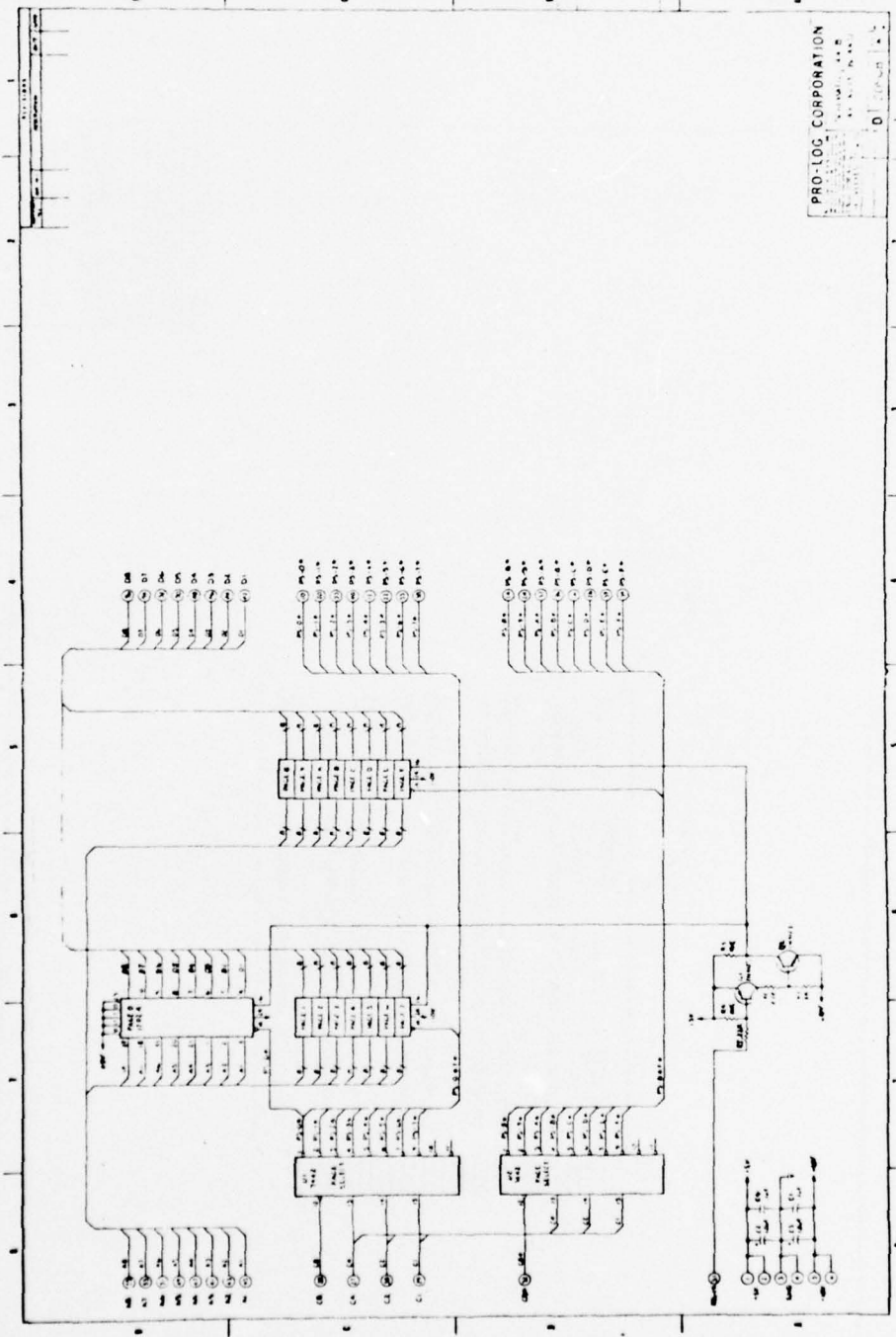

BEST AVAILABLE COPY

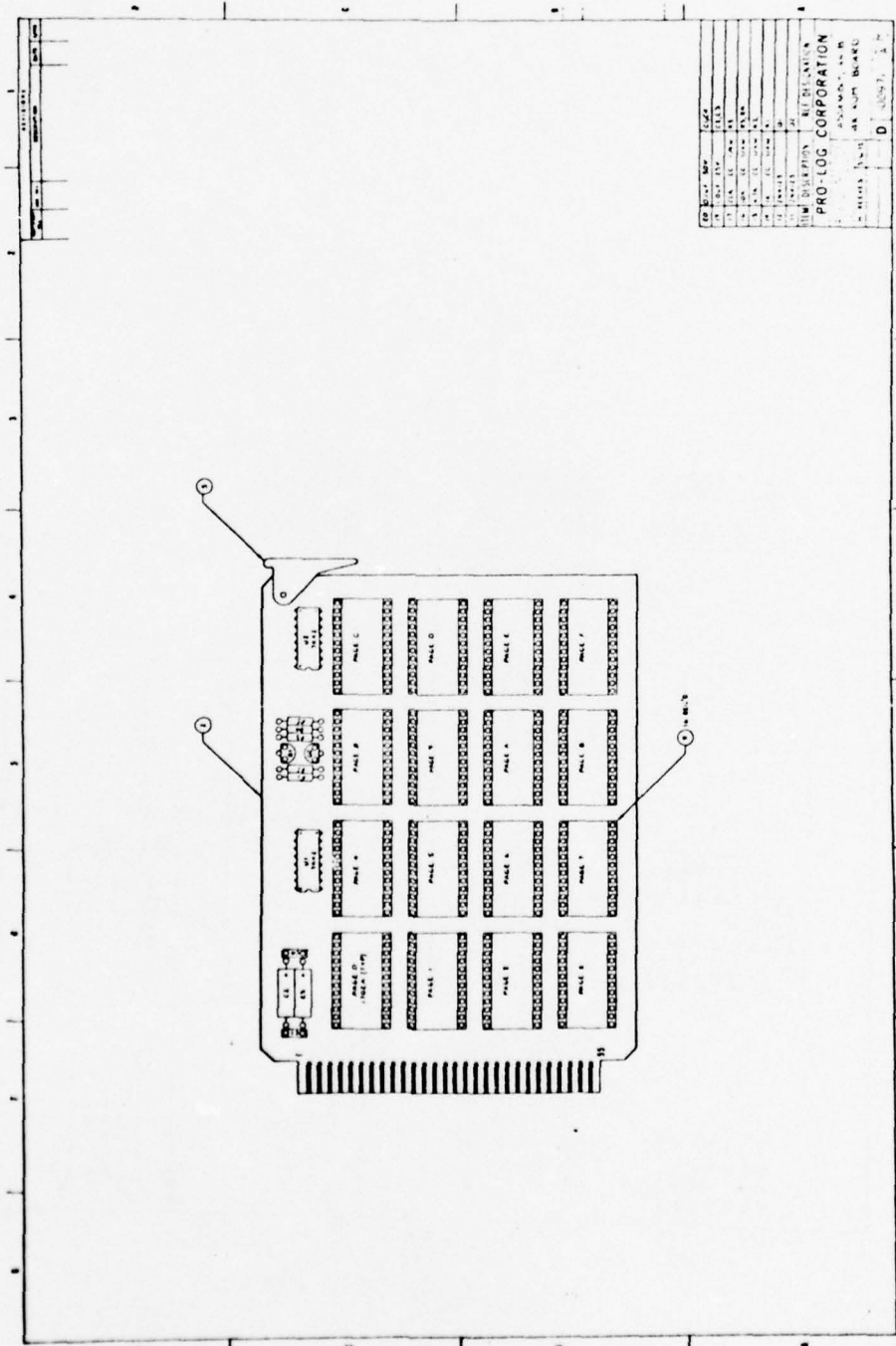

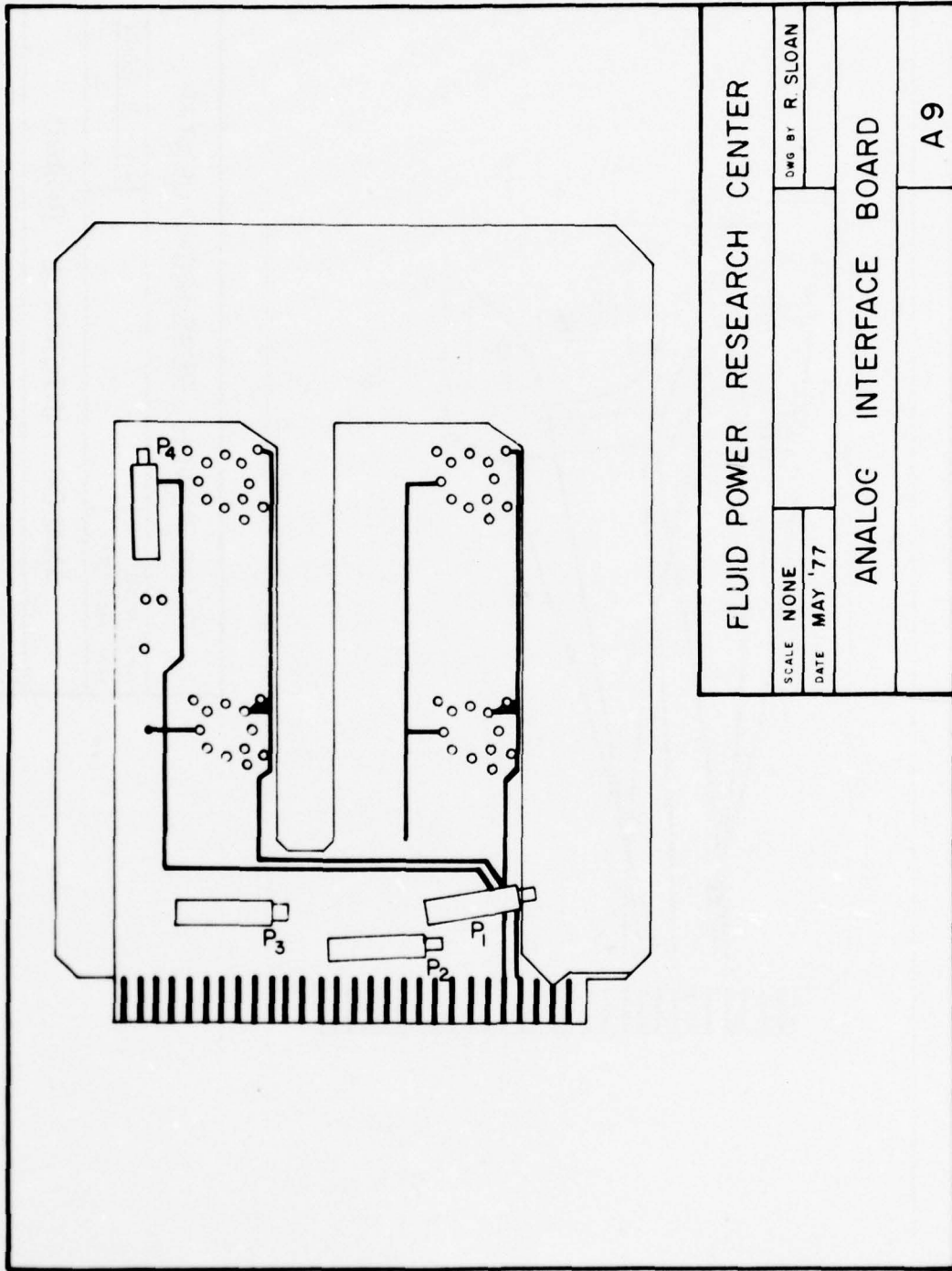

FLUID POWER RESEARCH CENTER	
SCALE NONE	DWG BY R. SLOAN
DATE MAY '77	
ANALOG INTERFACE BOARD	
	A 9

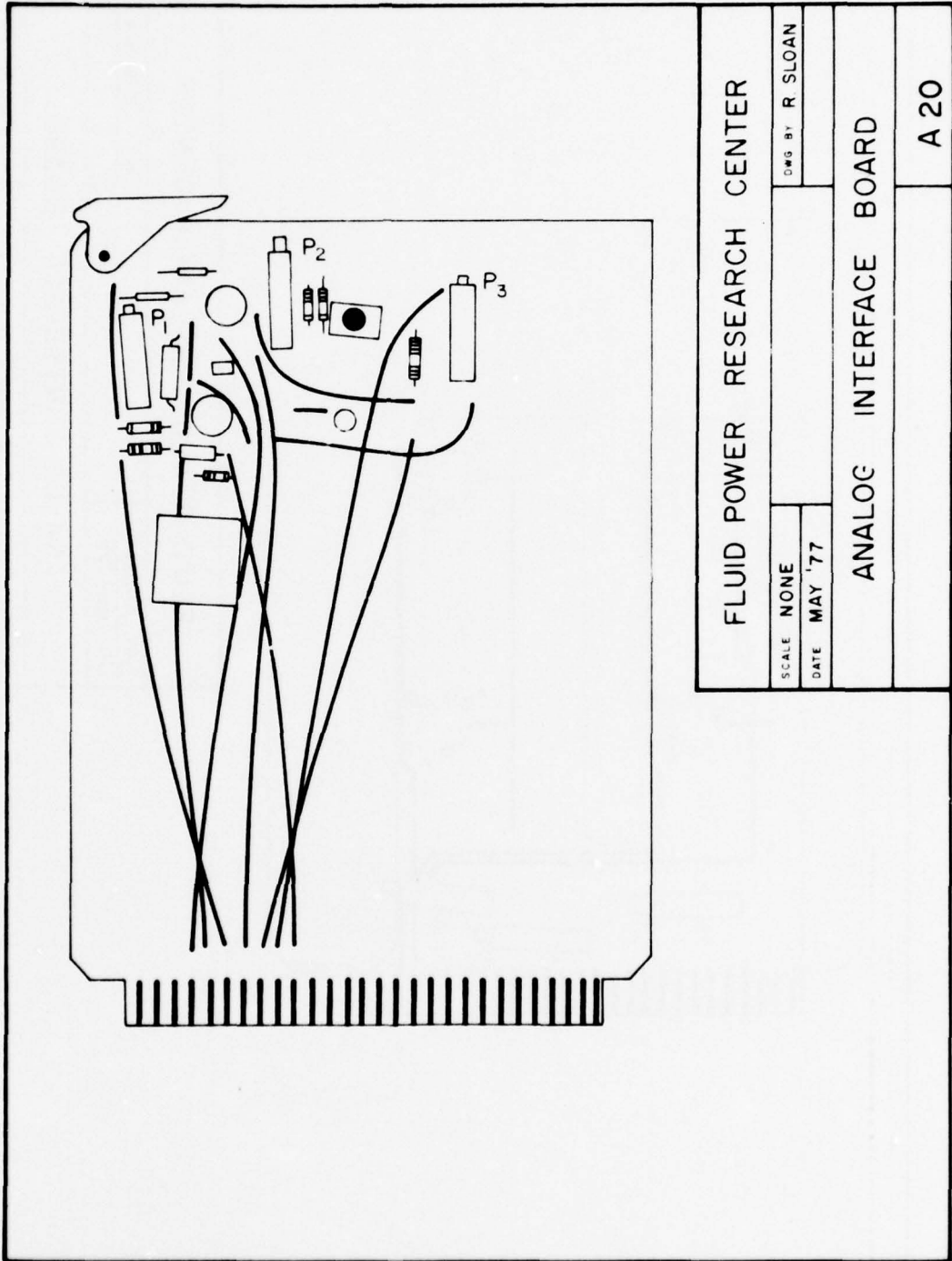

FLUID POWER RESEARCH CENTER

DWG BY R SLOAN

SCALE NONE

DATE MAY '77

ANALOG INTERFACE BOARD

A 20

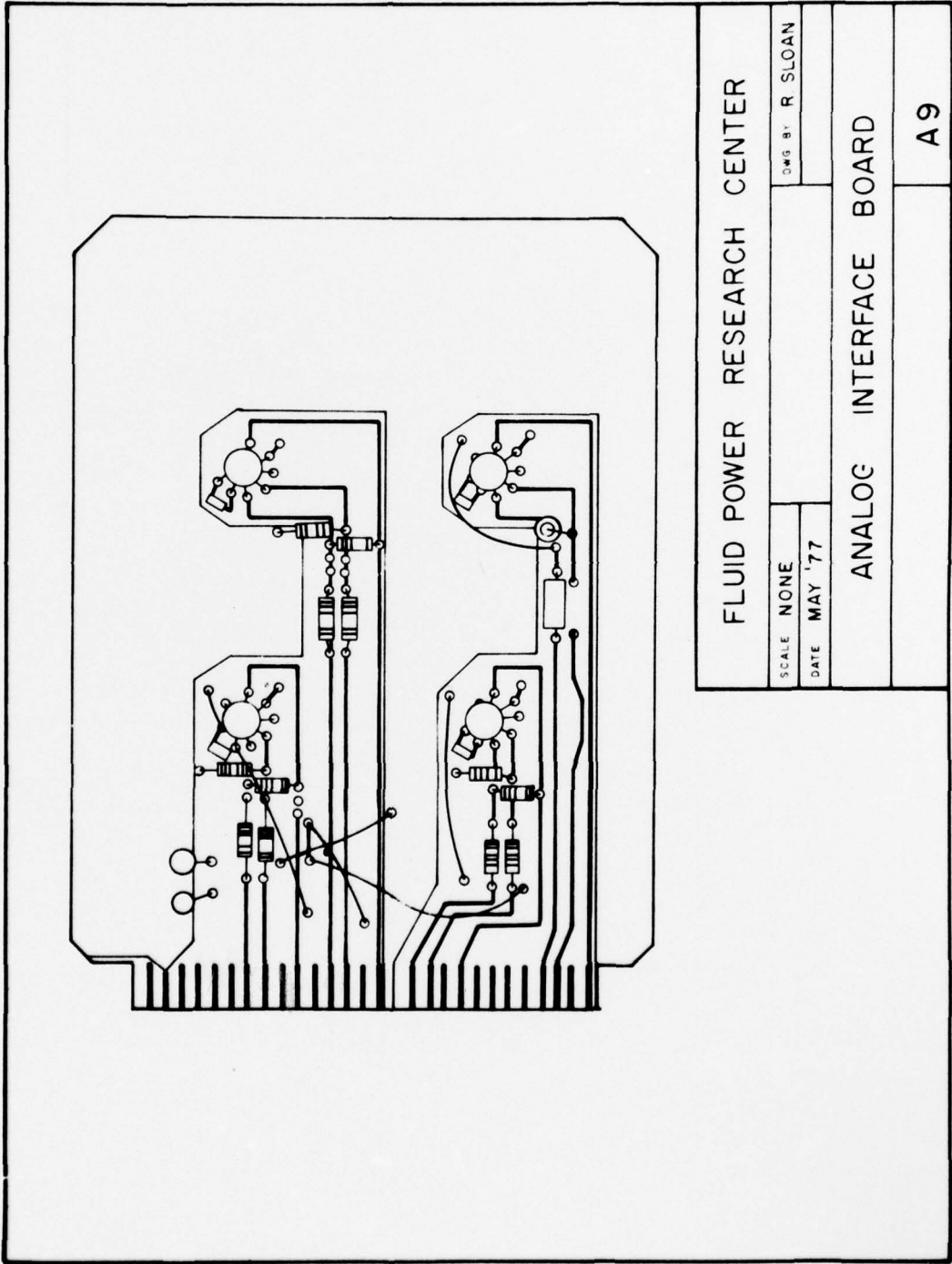

FLUID POWER RESEARCH CENTER	
SCALE NONE	DWG BY R. SLOAN
DATE MAY '77	
ANALOG INTERFACE BOARD	
	A9

APPENDIX B

The following is a listing of the micro-computer code for the SES. The codes are standard hexi-decimal codes for the Intel MCS-4. Each line of the listing specifies 16 "program lines." The address of the first "program line" is specified by a three hexi-decimal digit address in the first column.

PRECEDING PAGE ~~BLANK~~ NOT FILMED

PROGRAM MEMORY

PAGE #1

100 28 08 18 06 28 00 25 E9 23 E0 65 63 79 06 C0 00
110 00 00 F1 2F E9 F6 2F E0 F7 BF F8 BF F6 7D 13 C0
120 00 00 2F E9 F5 1A 36 FA 2F E9 F6 2F E0 F7 BF F8
130 BF F6 7D 28 18 43 F1 2F E9 F6 2F E0 F7 BF F8 BF
140 F6 7D 37 C0 00 00 E9 F6 2F E0 F7 BF F8 BF F6 7D
150 20 28 22 E1 26 38 28 18 2A 00 2C 03 2E 18 24 10
160 50 D2 D0 2B E0 7B 63 2A 00 F1 21 E9 F5 06 14 76
170 28 10 2A 08 50 2D 2E 0F 2C 00 51 22 21 E9 06 14
180 87 F8 14 8F F8 14 97 2E 0F 2C 00 51 22 18 9F 2A
190 08 28 18 50 2D 18 87 28 10 2A 08 50 2D 18 87 2E
1A0 2F 2C 08 51 12 73 7C 72 7C C0 00 00 00 00 00
1B0 F1 2F E9 F5 2F E0 6F 7D B1 18 C4 FA 2F E9 F5 2F
1C0 E0 6F 7D BC C0 00 00 00 00 20 E1 26 38 2E 28 2C
1D0 08 24 20 50 D2 2E 10 2C 07 D0 2F E0 6F 7D D9 2E
1E0 17 D4 2F E0 28 2F 2A 0F 29 E9 F5 2B E9 F5 F5 06
1F0 14 FC F8 14 FA F8 14 FA 41 FC 42 10 2E 18 2C 03

PROGRAM MEMORY

PAGE #2

200 51 BB 2E 08 2C 08 51 B0 2A 08 28 20 50 2D 42 22
210 2E 18 2C 08 51 B0 2E 08 2C 08 51 B0 2A 08 28 28
220 50 2D 2A 08 2B E9 1C 2C 7B 24 42 3C 61 A1 1C 34
230 63 A0 14 47 2E 17 2C 08 51 36 41 E4 61 2E 18 2C
240 08 51 B0 71 3D 70 3D 2E 18 2C 08 51 B0 2E 17 2F
250 E9 F5 FA F6 2F E0 2A 18 28 10 50 2D C0 00 00 00
260 00 00 03 23 34 26 28 56 00 20 38 26 20 56 00 20
270 3C 25 30 56 03 22 18 24 68 51 00 51 50 28 00 2A
280 20 50 2D 22 28 24 08 51 00 51 50 22 03 24 03 51
290 00 28 00 2A 30 50 2D 42 A9 E9 2E 00 2C 08 2F E0
2A0 6F 7D 9E 00 00 00 00 00 00 22 0C 5E C0 24 98 5E
2B0 F7 14 B6 24 98 5F F0 24 A0 5E F7 C0 00 51 00 20
2C0 28 26 28 56 00 23 2C 26 20 56 00 20 30 26 38 20
2D0 DD A3 23 F4 E2 3A 5A 39 63 71 D1 42 E0 40 48 50
2E0 20 EB A3 23 F4 E2 3A 5A 34 42 F0 58 60 68 70 78
2F0 63 71 E2 C0 2E F0 2F D1 E2 F4 E2 F4 E2 C0 00 22

PROGRAM MEMORY

PAGE #3

```
300 53 70 5E 20 40 0A 00 00 00 BB BF 8A 3F FF 00 BE
310 21 FF 3F 21 BF 22 20 FF BF FF BF FF 9B BF 82 BF
320 22 58 5E C0 24 30 5E F7 14 2E 24 30 5F F0 24 88
330 5E F7 22 60 5E C0 24 98 5E F7 14 40 24 98 5F F0
340 24 90 5E F7 00 00 20 57 22 18 34 51 00 61 22 28
350 34 51 00 53 8A 43 60 88 90 80 88 98 88 90 30 90
360 51 50 53 B6 61 32 24 01 51 00 71 48 C0 00 30 00
370 2E 20 2F A8 E4 A9 E5 AA E6 AB E7 C0 00 2E 10 2F
380 A4 E4 A5 E5 A6 E6 A7 E7 C0 00 2E 00 2F A0 E4 A1
390 E5 A2 E6 A3 E7 C0 00 00 00 00 2E 20 2F EC B8 ED
3A0 B9 EE BA E7 BB C0 00 00 2E 10 2F EC B4 ED B5 EE
3B0 B6 EF B7 C0 00 00 2E 00 2F EC B0 ED B1 EE B2 EF
3C0 B3 C0 DD F4 D9 EF AF 9C 3F AD AA AD AE BC D5 48
3D0 2F DF 00 26 0E 20 30 54 00 22 18 24 30 51 00 22
3E0 28 24 A0 51 00 51 50 22 A8 24 04 51 00 22 28 24
3F0 98 51 00 51 50 22 B0 24 04 51 00 C0 00 00 00 00
```

PROGRAM MEMORY

PAGE #4

```
400 2E 30 D0 2F E0 7F 03 53 7D 34 71 0D 60 22 18 51
410 00 53 8A 30 26 28 56 00 51 50 28 00 2A 30 50 33
420 24 00 22 30 51 04 53 B6 71 2B 60 53 A8 77 07 C0
430 40 40 48 44 A8 4C B0 50 80 6C 88 70 80 74 88 70
440 B8 78 B8 30 10 BE 12 B6 00 00 FE 56 54 FE 50 FF
450 20 80 26 70 56 00 20 84 26 68 56 00 20 88 26 50
460 56 00 20 8C 26 40 56 00 20 90 26 48 56 00 B8 F0
470 B8 39 F0 B9 53 70 40 0E 30 00 B4 00 20 10 34 02
480 2E 70 2F EA 2E 20 2F E0 53 9A 2E 21 A8 2F E0 2E
490 22 2F A9 E0 5E 20 01 32 00 00 00 14 48 FE 00 7F
4A0 54 94 02 00 04 10 34 54 38 32 1E 00 B6 32 34 10
4B0 10 00 00 00 36 12 DE 00 36 34 30 00 32 10 10 00
4C0 10 10 B4 34 3A 10 B6 BE 18 00 00 16 6C FE 10 FF
4D0 00 30 3C 30 38 30 30 BE 00 00 40 54 10 3F 04 FC
4E0 00 FC 00 00 9E 3C FF 00 34 B6 34 00 BC 30 14 30
4F0 06 5C 00 00 04 00 14 00 30 30 34 30 30 34 10 00
```

PROGRAM MEMORY

PAGE #5

500 00 00 00 22 68 5E C0 24 28 5E F5 26 08 20 48 56
510 00 51 C9 2E 08 2C 08 51 B0 22 18 24 08 51 00 22
520 28 24 50 51 00 51 50 22 B8 24 04 51 00 C0 00 00
530 00 00 00 20 54 26 20 56 00 26 0E 20 34 54 00 22
540 30 24 34 51 00 28 30 2A 20 50 2D 22 80 24 08 51
550 00 C0 00 00 BF 83 01 EF 49 CF CF 4F CF 4D C1 EF
560 22 68 5E C0 24 18 5E F5 22 28 24 70 51 00 51 50
570 22 90 24 02 51 00 C0 00 00 CD B7 FD 86 81 D5 E1
580 20 58 26 30 56 00 20 5C 26 28 56 00 20 60 26 38
590 56 00 28 B8 2A 30 50 2D 22 18 24 08 51 00 51 50
5A0 22 18 24 03 51 00 28 90 2A 18 50 2D 28 08 2A 38
5B0 50 2D 22 88 24 08 51 30 C0 00 00 00 FB 10 01 68
5C0 26 0E 20 38 54 00 22 C0 24 33 51 00 26 0D 20 3C
5D0 54 00 20 7C 26 18 56 00 28 18 2A 33 50 2D 22 C8
5E0 24 08 51 00 C0 00 CD 44 00 00 0D 01 C4 00 00 00
5F0 41 FF EF C8 47 47 FF CF 00 9B 4A 84 D5 B9 80 E3

PROGRAM MEMORY

PAGE #6

```
600 24 0C 18 06 24 0E 32 A2 27 E0 67 A3 27 E0 67 61
610 75 06 C0 30 36 BC 3E BE 00 00 6A 00 00 3D 00 FD
620 55 DF FF FF 00 00 00 01 AA 00 00 00 00 00 8F
630 00 00 00 01 99 AD FF FF CC F7 84 BF C9 11 5A 20
640 DC A0 00 00 E6 3F FF FF E9 90 00 00 00 00 EF FF
650 00 08 DF FF 00 34 94 00 00 C0 30 00 5D A0 00 00
660 00 A3 42 00 00 00 A0 00 00 00 20 00 2C 50 00 00
670 2E 0F FF FF E3 AF FF FF 5F 82 00 00 00 70 64 00
680 00 00 EF FF 00 30 00 00 00 F0 00 00 00 60 00 00
690 00 50 00 00 30 10 00 BE 00 00 02 00 0E 50 00 FF
6A0 10 16 02 00 00 14 B6 FF 10 3C B4 30 BC 10 30 10
6B0 50 00 00 00 00 10 16 00 B6 3C 34 30 30 10 10 00
6C0 30 10 34 30 B6 32 90 3C 00 10 7E 64 10 F6 00 FF
6D0 00 3A B4 30 30 34 32 BE 00 00 38 CE DE 08 04 FE
6E0 00 FE 00 7C 14 44 F6 BE 3E 3C 30 30 B6 34 10 10
6F0 20 D2 00 00 00 10 FC 10 10 30 10 10 B4 10 34 30
```

PROGRAM MEMORY

PAGE #A

A00 2C 9D F1 2E A0 00 30 2F EA F5 00 00 2B E0 6B 6E
A10 7D 07 00 00 D0 12 18 F4 2B E0 6B 7C 18 C0 00 00
A20 2C BD 2E A0 2F EA 2B 00 E0 6B 6E 7D 24 D0 2B E0
A30 6B 7C 2E C0 52 F4 4A 00 00 52 F4 4A 20 00 00 00
A40 22 28 24 80 51 00 28 28 40 60 02 76 22 5F 02 7F
A50 22 28 24 C8 51 00 28 28 40 A3 00 00 02 7F 00 FF
A60 22 18 24 C0 51 00 20 80 26 28 56 00 28 28 40 B2
A70 02 00 00 10 00 00 02 00 00 00 10 00 34 00 00 00
A80 00 00 34 00 20 30 10 7C 02 02 00 02 52 77 02 FF
A90 00 00 00 00 30 00 00 74 00 02 00 02 42 52 02 FF
AA0 02 02 52 00 12 12 12 7F 00 10 34 00 74 04 00 00
AB0 00 00 00 00 00 00 02 02 74 10 00 00 60 00 00 00
AC0 00 00 00 00 70 10 00 70 02 40 7A 16 02 76 02 FF
AD0 00 74 30 00 00 00 10 7C 02 02 52 56 52 12 02 FF
AE0 00 76 00 32 06 02 3F 3F 10 30 30 00 30 10 00 00
AF0 00 52 00 02 00 02 77 02 00 00 00 00 70 20 00 00

PROGRAM MEMORY

PAGE #E

E00 2C D1 F1 2E F8 00 00 2B E9 2F F4 E2 AD 2D 30 E2
E10 F5 BD D0 E2 1A 1B F1 6D 6C 00 00 6B 7F 07 C0 00
E20 00 00 11 20 20 30 22 80 23 EA 00 00 00 03 4E 3A
E30 80 88 C0 C8 98 A0 B8 90 A8 B0 B1 3A 5E 00 00 C0
E40 08 00 60 10 38 00 40 F1 90 80 91 99 D0 FF 80 FD
E50 20 00 80 40 40 40 00 F8 80 80 00 90 80 FD 08 DD
E60 D1 91 80 80 91 88 D0 91 00 F8 00 88 78 40 00 00
E70 91 90 00 00 08 80 80 08 00 40 80 00 B0 00 00 00
E80 00 80 F8 00 00 40 00 F8 90 90 90 90 91 D1 90 ED
E90 20 00 00 30 60 00 00 F8 80 80 90 00 B0 99 90 FF
EA0 D1 90 91 80 80 D1 99 F9 00 B0 48 00 F0 10 00 80
EB0 90 88 00 00 00 90 91 00 B8 50 C8 08 50 00 00 00
EC0 26 0C D3 F1 83 B5 A2 B4 25 E9 1C DC 00 00 63 23
ED0 E9 07 B1 00 00 63 23 E9 B0 C0 00 00 FA 23 E9 F4
EE0 86 00 00 63 23 E9 F4 86 07 B1 00 63 23 E9 F4 86
EF0 B0 CF 00 80 80 61 61 BF 00 00 5F D0 7F FF CF C0

PROGRAM MEMORY

PAGE #F

```
F00 00 00 FF FF 91 40 FF FF FE 70 FF FF 80 C0 EB FF
F10 FD F0 D7 FF 8F 31 B3 FF 01 81 AF EF 7E B1 77 EF
F20 00 02 4F DF 7D 32 17 DF FE 72 EE CF 7C B2 92 CF
F30 E9 F2 46 BF 6B 33 F9 AF D8 73 BD 9F 46 B3 71 9F
F40 B3 F3 01 8F 12 34 A0 7F B2 74 40 6F 20 B4 CB 4F
F50 89 E4 6C 3F F6 25 F6 2F 64 65 5E 0F BD 95 E9 FE
F60 2B D5 65 EE 98 16 DC CE F1 56 44 BE 4B 86 97 9E
F70 B8 C6 FE 7E 12 07 52 6E 6B 37 A5 4E C4 77 F8 2E
F80 F9 A7 5C 0E 53 E7 8B ED BC 18 CA CD F1 58 F9 AD
F90 37 88 39 89 7C B8 78 6D C5 F8 93 4D 72 19 2F 2D
FA0 3C 59 E9 FC 71 99 F4 DC 92 C9 1C AC B3 F9 37 8C
FB0 F8 2A 3E 5C 2A 5A 45 3C 37 8A 5C 0C 58 BA 4F DB
FC0 98 EA 46 BB 86 1B 39 8B 93 4B 3C 5B 8F 97 87 BF
FD0 2C CE 25 36 A6 E0 65 25 A7 E0 00 00 61 65 7D D2
FE0 00 00 D0 25 E0 65 7C E3 C0 82 02 00 26 2E A6 0A
FF0 FA 26 08 25 E9 F4 86 E0 65 77 F3 C0 AF 2E A6 6F
```

PROGRAM MEMORY

PAGE #0

```
000 00 00 B8 F0 B8 B9 F0 B9 53 70 22 90 52 CF 52 63
010 53 D3 55 03 55 33 20 64 26 18 56 00 4A 40 40 60
020 58 40 5D 40 00 00 DF 08 00 54 00 00 00 2E 08 2C
030 08 18 37 2E 00 2C 00 F1 2B E9 29 EB 2F E0 6F 6B
040 69 7D 38 C0 00 00 00 2E 08 2C 08 18 51 2E 0C 2C
050 0C FA 29 E9 F4 8C E0 69 7D 52 D8 F1 89 B9 40 37
060 2A 18 50 47 53 9A 2E 0F 2F E9 F5 1A 81 B8 F0 B8
070 B9 14 7A 2E 70 2F D8 E2 40 93 2E 70 2F D0 E2 40
080 93 B8 D1 B8 B9 14 8E 2E 70 2F D9 E2 40 93 2E 70
090 2F D1 E2 53 70 55 60 55 80 55 C0 20 68 26 18 56
0A0 00 4A 50 2A 18 50 47 00 00 2E 0F 2F E9 F5 1A E5
0B0 4A 60 2A 18 50 47 2E 0F 2F E9 F5 1A E5 53 9A B9
0C0 F0 B9 B8 14 CC 2E 70 2F D1 E2 43 00 2E 70 40 E0
0D0 00 00 FA 2F E9 F4 8C 25 E0 6F 65 7D D3 C0 00 00
0E0 2F D0 E2 43 00 53 9A B9 D1 B9 B8 14 F4 2E 70 2F
0F0 D9 E2 43 00 2E 70 2F D8 E2 43 00 44 28 0C 41 06
```

APPENDIX C

Many, if not most, modern computers operate on numbers which have been represented in binary code as opposed to some form of binary coded decimal. The SES processes 32-bit binary integers digits expressed in twos compliment format. As a shorthand notation, the binary digits are often separated into groups of four bits. Each group is one digit in hexi-decimal notation (Base 16). The 32-bit binary word can be expressed as an eight digit hexi-decimal number. The hexi-decimal numbers are 0, 1, 2, 3, 4, 5, 6, 7, 8, 9, A, B, C, D, E, and F, which represent decimal numbers 0 to 15.

The twos compliment notation allows for a means of representing both positive and negative numbers. Although well suited for the computer, the notation poses difficulties to the novice. The following procedures are presented to aid in the conversion to and from this notation.

CONVERSION FROM DECIMAL

1. Round the decimal number to the nearest integer. Convert this to hexi-decimal notation.
2. Pad the number with insignificant zeros (zeros to the right of the number) in order to obtain eight hexi-decimal digits.
3. If the number is positive, the twos compliment number is calculated in Step 2. If the number is negative, then subtract this number from FFFFFFFF (Base 16). Add 00000001 (Base 16) to obtain the proper number.

PRECEDING PAGE BLANK NOT FILMED

CONVERSION TO DECIMAL

1. If the number is less than or equal to 7FFFFFFF (Base 16), then the number is positive, and this step should be skipped. If greater than 7FFFFFFF (Base 16), the number is negative, and it should be subtracted from FFFFFFFF (Base 16). Add 00000001 (Base 16) to this result and use this number in the next step.
2. Convert the hexi-decimal number to decimal by conventional means. The sign of the number is as stated in Step 1.

It should be noted that Codes 00000000 to 7FFFFFFF represent positive numbers, while 80000000 to FFFFFFFF represent positive numbers. The positive numbers are simply the Base 16 representation of a decimal integer, but the negative numbers can be thought of as counting backwards; i.e., FFFFFFFF represents the least negative integer (-1), and 80000000 represents the most negative integer (-2.68×10^8).