

AD-A041 217

IBM CORP CAPE CANAVERAL FLA
DESIGN OF TRAINING SYSTEMS. COMPUTERIZATION OF THE EDUCATIONAL --ETC(U)
MAY 77 L R DUFFY, R B MILLER, J D STALEY N61339-73-C-0097
TAEG-40-VOL-1 NL

F/G 5/1

UNCLASSIFIED

1 OF 3

AD
A041217



ADA 041 217

TAEAG

Handwritten initials and circled number 12

TRAINING
ANALYSIS
AND
EVALUATION
GROUP

TAEAG REPORT
NO. 40

DESIGN OF TRAINING SYSTEMS

COMPUTERIZATION OF THE EDUCATIONAL TECHNOLOGY
ASSESSMENT MODEL (ETAM) - VOLUME 1



FOCUS
ON
THE
TRAINED
MAN

AD 12
DDC FILE COPY

Approved for public release;
distribution is unlimited.

DDC
RECEIVED
JUL 5 1977
A

MAY 1977



TRAINING ANALYSIS AND EVALUATION GROUP
ORLANDO, FLORIDA 32813

DESIGN OF TRAINING SYSTEMS
COMPUTERIZATION OF THE EDUCATIONAL TECHNOLOGY ASSESSMENT MODEL (ETAM)
VOLUMES 1 AND 2

ABSTRACT

This two volume final report summarizes the analysis, design and development activities associated with the Educational Technology Assessment Model (ETAM). It contains relevant background information and results of prior studies leading to the finalized ETAM procedures and computerized routines. A comparison of the manual versus the automated approach is included. Data base structures and the ETAM program flow are described and related to each other. The appendix includes the results of a study on the indexing of innovations and the assignment of taxonomic descriptors to courses, job/tasks, and instructional vehicles. The appendix also includes program documentation on the ETAM Range-of-Effect, bibliographic references, and additional information supporting the ETAM design. The detailed ETAM procedures supporting this report are included in TAEG Report No. 12-3, Phase II-A Report. TAEG Report No. 32, The Development of Scaling Procedures, supports the computerized approach taken in scaling variables. Other important background and reference information can also be found in a report written by Drs. R. B. Miller and A. F. Smode titled "Major Innovations in Training Technology."

Phases I, II, II-A, III and IV were accomplished by the IBM Federal Systems Division with the Training Analysis and Evaluation Group, Orlando, Florida, providing technical guidance and support. The overall DOTS objective is to provide Naval Education and Training Command (NAVEDTRACOM) management with additional tools in the form of computerized mathematical models to assist in predicting the quantitative impact of training resource decisions. The planning process will be enhanced by providing decision makers with the capability to economically and rapidly consider a wider range of alternatives.

Phase I was a study and definition effort resulting in a complete functional description of the NAVEDTRACOM; a strategic definition of the social, political, economic and technological environments pertinent to the naval education and training system in the 1980's; a list of existing and potential models amenable to computerization and to improving the decision-making process.

Phase II was devoted to the selection and development of three mathematical models from the Phase I list of candidates. The three were the System Capabilities/Requirements and Resources (SCRR), the Individualized Training Simulation System (ITSS), and the Training Process Flow (TPF) models.

Phase III centered on evaluating the selected models at the Fleet Training Center, Norfolk, VA. An important recommendation from the Test and Evaluation conducted during Phase III was that DOTS should investigate model applications at higher command levels.

Phase IV responded to the recommendations of Phase III by (1) operating and testing at TRAPAC, San Diego, CA, the models developed in Phase II, and (2) developing a new Training Requirements Analysis Model (TRAM) and field testing it at CNTECHTRA, Memphis, Tenn.

The major effort supporting Phase II-B was the ETAM procedural development during Phase II-A. In addition to the procedural development, computer applications were described, scenarios using the ETAM procedures were prepared, and ETAM validity and logical structure were confirmed.

UNCLASSIFIED

SECURITY CLASSIFICATION OF THIS PAGE (When Data Entered)

REPORT DOCUMENTATION PAGE		READ INSTRUCTIONS BEFORE COMPLETING FORM
1. REPORT NUMBER 18 TAEG Report No. 40 - Vol-1	2. GOVT ACCESSION NO. (9) Final	3. RECIPIENT'S CATALOG NUMBER Rept. Aug 76 - May '77
4. TITLE (and Subtitle) 6 DESIGN OF TRAINING SYSTEMS. Computerization of the Educational Technology Assessment Model (ETAM), Volume 1		5. TYPE OF REPORT & PERIOD COVERED Final 8/76 - 5/77
7. AUTHOR(s) 10 Larry R. Duffy, Robert B. Miller, Ph.D. James D. Staley		8. CONTRACT OR GRANT NUMBER(s) N61339-73-C-0097
9. PERFORMING ORGANIZATION NAME AND ADDRESS 1 International Business Machines 7900 N. Astronaut Blvd. Cape Canaveral, FL 32920		10. PROGRAM ELEMENT, PROJECT, TASK AREA & WORK UNIT NUMBERS
11. CONTROLLING OFFICE NAME AND ADDRESS Naval Training Equipment Center Training Analysis and Evaluation Group Orlando, FL		12. REPORT DATE 11 May 1977
14. MONITORING AGENCY NAME & ADDRESS (if different from Controlling Office)		13. NUMBER OF PAGES 184 (12) 193p
		15. SECURITY CLASS. (of this report) UNCLASSIFIED
		15a. DECLASSIFICATION/DOWNGRADING SCHEDULE
16. DISTRIBUTION STATEMENT (of this Report) Approved for Public Release: Distribution is Unlimited.		
17. DISTRIBUTION STATEMENT (of the abstract entered in Block 20, if different from Report)		
18. SUPPLEMENTARY NOTES		
19. KEY WORDS (Continue on reverse side if necessary and identify by block number) Training Management Systems Training Technology Computer Based Models Interactive Training Data Base Training Resources Evaluation Modeling Decision Theory Educational Technology		
20. ABSTRACT (Continue on reverse side if necessary and identify by block number) This two volume final report summarizes the analysis, design and development activities associated with the Educational Technology Assessment Model (ETAM). It contains relevant background information and results of prior studies leading to the finalized ETAM procedures and computerized routines. A comparison of the manual versus the automated approach is included. Data base structures and the ETAM program flow are described and related to each other. The appendix includes the results of a study on the indexing of innovations and the assignment of taxonomic descriptors to courses, job/tasks, and instructional vehicles.		

DD FORM 1 JAN 73 1473

EDITION OF 1 NOV 68 IS OBSOLETE
S/N 0102-LF-014-6601

UNCLASSIFIED

SECURITY CLASSIFICATION OF THIS PAGE (When Data Entered)

410210

UNCLASSIFIED

SECURITY CLASSIFICATION OF THIS PAGE (When Data Entered)

20. ABSTRACT (Cont'd)

The appendix also includes program documentation on the ETAM Range-of-Effect, bibliographic references, and additional information supporting the ETAM design. The detailed ETAM procedures supporting this report are included in TAEG Report No. 12-3, Phase II-A Report. TAEG Report No. 32, The Development of Scaling Procedures, supports the computerized approach taken in scaling variables. Other important background and reference information can also be found in a report written by Drs. R. B. Miller and A. F. Smode titled "Major Innovations in Training Technology."

cont. from p. 10/15/84 → *The overall design of training systems*
Phases I, II, II-A, III and IV were accomplished by the IBM Federal Systems Division with the Training Analysis and Evaluation Group, Orlando, Florida, providing technical guidance and support. The overall DOTS objective is to provide Naval Education and Training Command (NAVEDTRACOM) management with additional tools in the form of computerized mathematical models to assist in predicting the quantitative impact of training resource decisions. The planning process will be enhanced by providing decision makers with the capability to economically and rapidly consider a wider range of alternatives.

Phase I was a study and definition effort resulting in a complete functional description of the NAVEDTRACOM; a strategic definition of the social, political, economic and technological environments pertinent to the naval education and training system in the 1980's; a list of existing and potential models amenable to computerization and to improving the decision-making process.

Phase II was devoted to the selection and development of three mathematical models from the Phase I list of candidates. The three were the System Capabilities/Requirements and Resources (SCRR), the Individualized Training Simulation System (ITSS), and the Training Process Flow (TPF) models.

Phase III centered on evaluating the selected models at the Fleet Training Center, Norfolk, VA. An important recommendation from the Test and Evaluation conducted during Phase III was that DOTS should investigate model applications at higher command levels.

Phase IV responded to the recommendations of Phase III by (1) operating and testing at TRAPAC, San Diego, CA, the models developed in Phase II, and (2) developing a new Training Requirements Analysis Model (TRAM) and field testing it at CNTECHTRA, Memphis, Tenn.

The major effort supporting Phase II-B was the ETAM procedural development during Phase II-A. In addition to the procedural development, computer applications were described, scenarios using the ETAM procedures were prepared, and ETAM validity and logical structure were confirmed.

UNCLASSIFIED

SECURITY CLASSIFICATION OF THIS PAGE (When Data Entered)

TAEG REPORT NO. 40

DESIGN OF TRAINING SYSTEMS
COMPUTERIZATION OF THE EDUCATIONAL
TECHNOLOGY ASSESSMENT MODEL (ETAM)
VOLUME 1

Robert B. Miller
Larry R. Duffy
James D. Staley

This Study Was Performed by
International Business Machines Corporation
for the
Training Analysis and Evaluation Group

May 1977

SEARCHED	INDEXED	<input checked="" type="checkbox"/>
SERIALIZED	FILED	<input type="checkbox"/>
MAY 1977		
FBI - MEMPHIS		
DISTRIBUTION STATEMENT CODES		
DIAG.	REF.	SPECIAL
A		

GOVERNMENT RIGHTS IN DATA STATEMENT
Reproduction of this publication in whole
or in part is permitted for any purpose
of the United States Government.

Alfred F. Smode
ALFRED F. SMODE, Ph.D., Director
Training Analysis and Evaluation Group

FOREWORD

The Design of Training Systems (DOTS) project objectives are in consonance with the requirements of Advanced Development Objective ZPN07 (formerly ADO 43-03X), Education and Training Development. ZPN07 includes a number of projects concerned with demonstrating and evaluating the technical, operational and financial feasibility of applying advanced technological applications to improving the training process.

The Bureau of Naval Personnel initiated the original ADO in 1966 to make naval training more responsive to the changing times. As one project under this effort, DOTS was designed to improve the process of managing training resources through application of the techniques of system analysis and system simulation as accomplished through mathematical modeling. The end objective is a family of computerized mathematical models enabling training management to more rapidly predict the impact of changes in training resource availability or requirements.

The majority of education and training was reorganized in 1971 under one command, Chief of Naval Education and Training (CNET). Because of this change, DOTS responsibility was transferred to CNET in March of 1972; more specifically, to the Training Analysis and Evaluation Group (TAEG), Orlando, Florida. The new CNET organization greatly increased the potential benefits to be gained from the increased application of new management techniques and, therefore, from the DOTS' R&D effort. DOTS began in February of 1973, with the majority of tasking being contracted to the International Business Machines Corporation, Federal Systems Division, Cape Kennedy Facility, located at Cape Canaveral, Florida.

The Training Analysis and Evaluation Group, Dr. A. Smode, Director, project team members Messrs. M. Middleton and W. Lindahl, complemented the contracted effort by providing direction and guidance and in establishing organizational interfaces.

The model was developed by Mr. L. R. Duffy, Dr. R. B. Miller, and Mr. J. D. Staley. Mr. R. E. Hallman and Mr. L. R. Duffy provided management for the project.

TABLE OF CONTENTS

<u>SECTION</u>		<u>PAGE</u>
I	INTRODUCTION	
	BACKGROUND.	I-1
	ASSUMPTIONS ABOUT USING THE MODEL	I-2
	OBJECTIVES FOR ETAM	I-3
II	ETAM FUNCTIONAL REQUIREMENTS	
	PROCEDURAL REQUIREMENTS	II-1
	DESIGN REQUIREMENTS	II-5
III	ETAM DEVELOPMENT	
	PRELIMINARY STUDIES	III-1
	ETAM PROGRAM FLOW	III-5
	ETAM PROGRAM FUNCTIONS.	III-40
IV	CONCLUSIONS AND RECOMMENDATIONS	
	CONCLUSIONS	IV-1
	RECOMMENDATIONS	IV-7

TAEG REPORT NO. 40

LIST OF FIGURES

<u>FIGURE NO.</u>	<u>TITLE</u>	<u>PAGE</u>
II-1	ETAM PROCEDURAL SEQUENCE	II-2
II-2	ETAM STRUCTURE	II-7
II-3	SAMPLE COURSE ABBREVIATED DATA BASE CONTENTS . .	II-15
II-4	SAMPLE JOB ABBREVIATED DATA BASE CONTENTS. . . .	II-17
II-5	SAMPLE TRAINING VEHICLE ABBREVIATED DATA BASE CONTENTS	II-17
III-1	ETAM PROGRAM/DATA BASE FLOW.	III-6
III-2	ID FILE EXAMPLE.	III-8
III-3	REC FILE EXAMPLE	III-10
III-4	SARG FILE EXAMPLE.	III-12
III-5	RESU FILE EXAMPLE.	III-13
III-6	EXC DATA ELEMENTS.	III-15
III-7	EXV DATA ELEMENTS.	III-16
III-8	EXJ DATA ELEMENTS.	III-17
III-9	BPT FILE EXAMPLE	III-18
III-10	RKP FILE EXAMPLE	III-20
III-11	RRPJ FILE EXAMPLE.	III-23
III-12	RRPK FILE EXAMPLE.	III-25
III-13	VQAL FILE EXAMPLE.	III-26
III-14	VARF FILE EXAMPLE.	III-28
III-15	SCEN FILE EXAMPLE.	III-29
III-16	ALTP FILE EXAMPLE.	III-32
III-17	ETAM PROCESSING SEQUENCE	III-35
III-18	ETAM CONTROL EXEC.	III-41
III-19	ETAM CONTROL EXEC DISPLAY PATTERNS	III-42
III-20	EXAMPLE OF PROGRAM P17	III-44

TAEG REPORT NO. 40

<u>FIGURE NO.</u>	<u>TITLE</u>	<u>PAGE</u>
III-21	EXAMPLE OF PROGRAM P1.	III-46
III-22	EXAMPLE OF PROGRAM P2.	III-56
III-23	EXAMPLE OF PROGRAM P3.	III-57
III-24	EXAMPLE OF PROGRAM P5A	III-58
III-25	EXAMPLE OF PROGRAM P5B	III-61
III-26	EXAMPLE OF PROGRAM P5C	III-64
III-27	ETAM COST MODELS (MOD) PROCESS FLOW.	III-67
III-28	TRAINING COST MODEL - INPUT TECHNICAL FACTORS. .	III-78
III-29	TRAINING COST MODEL - INPUT COST FACTORS	III-79
III-30	TRAINING COST MODEL - OUTPUT TECHNICAL RESULTS .	III-80
III-31	TRAINING COST MODEL - OUTPUT TECHNICAL RESULTS YEARS 1-5.	III-81
III-32	TRAINING COST MODEL - OUTPUT TECHNICAL RESULTS YEARS 6-10	III-82
III-33	TRAINING COST MODEL - OUTPUT TECHNICAL RESULTS YEARS 11-15.	III-83
III-34	TRAINING COST MODEL - OUTPUT TECHNICAL RESULTS YEARS 16-20.	III-84
III-35	TRAINING COST MODEL - OUTPUT COST RESULTS. . . .	III-85
III-36	TRAINING COST MODEL - OUTPUT COST RESULTS YEARS 1-5.	III-86
III-37	TRAINING COST MODEL - OUTPUT COST RESULTS YEARS 6-10	III-87
III-38	TRAINING COST MODEL - OUTPUT COST RESULTS YEARS 11-15.	III-88
III-39	TRAINING COST MODEL - OUTPUT COST RESULTS YEARS 16-20.	III-89
III-40	TRAINING COST MODEL - ETAM OUTPUT FACTORS YEARS 1-10	III-90
III-41	TRAINING COST MODEL - ETAM OUTPUT FACTORS YEARS 11-20.	III-91
III-42	ETAM RISK REDUCTION (RISK) PROCESS FLOW.	III-99

TAEG REPORT NO. 40

<u>FIGURE NO.</u>	<u>TITLE</u>	<u>PAGE</u>
III-43	ETAM DECISION ANALYSIS (DTREE) PROCESS FLOW. . .	III-102
III-44	DECISION TREE FOR ASSESSMENT OF TRAINING INNOVATION	III-103
III-45	ETAM DECISION ANALYSIS DETAIL REPORT (DT01). . .	III-105
III-46	GRAPHICAL REPRESENTATION OF OUTCOME STATES BY ATTRIBUTE IN RELATION TO LEAST TOLERABLE AND GOAL STATES.	III-113
III-47	GRAPHIC EXAMPLE OF A SYSTEM UTILITY FUNCTION OVER THE ATTRIBUTE, DOLLARS.	III-118
III-48	APPLICATION OF IMPORTANCE WEIGHTS TO DEVELOP OVERALL SYSTEM UTILITY BY OUTCOME.	III-121
III-49	FORMAT OF ETAM DECISION OUTCOME STATES BY SCALED VARIABLE REPORT (DT02)	III-125
III-50	EXAMPLE OF ETAM DECISION OUTPUT STATES BY SCALED VARIABLE REPORT (DT02)	III-126
III-51	FORMAT OF ETAM DECISION OUTCOME STATES BY VARIABLE REPORT (DT03).	III-128
III-52	EXAMPLE OF ETAM DECISION OUTCOME STATES BY VARIABLE REPORT (DT03).	III-129
III-53	FORMAT OF ETAM DECISION VARIABLE VALUES BY OUTCOME REPORT (DT04).	III-130
III-54	EXAMPLE OF ETAM DECISION VARIABLE VALUES BY OUTCOME REPORT (DT04).	III-131
III-55	EXAMPLE OF ETAM DECISION VARIABLE VALUES BY OUTCOME REPORT (DT04).	III-132
III-56	ETAM FINANCIAL ANALYSIS (FIN) PROCESS FLOW . . .	III-138
III-57	FORMAT OF ETAM ALTERNATIVE ANALYSIS REPORT (FA01)	III-139
III-58	FORMAT OF ETAM ALTERNATIVE ANALYSIS SUMMARY REPORT (FA02)	III-146
III-59	EXAMPLE OF INTERACTIVE SEQUENCE FOR CALCULATING RETURN ON INVESTMENT (ROI)	III-151

SECTION I

INTRODUCTION

BACKGROUND

The benefits, costs and risks associated with introducing technical innovations in education and training can invoke large commitments of resources. The rational assessment of payoffs and penalties for investing in changes therefore deserves technical attention with the objective of arriving at sound decisions to accept or reject. In essence, this means making an analysis of the full potential range of applicability of the proposed innovation in terms of benefits, liabilities and risks, including financial analysis of costs, and synthesizing the mass of resulting data into a decision-making presentation. Key judgmental operations should, of course, be retained by humans. Explicitness in procedure and in the expression of human judgment is a key factor in rationality. The Educational Technology Assessment Model (ETAM) is a set of comprehensive procedures and variables for this analysis, synthesis and decision making. Although the content of this structure, or "model," is directed specifically towards education and training, the structure itself is applicable to any rational, decision-making context.

An innovation is broadly defined. In ETAM it is "a relatively constant or enduring change in the procedures, objects or functions used in any aspect of the instructional process which may be viewed as a benefit (or a liability) and has associated costs." Thus, an innovation may be a technical invention or it may be a structural change in the setting of instruction, such as from shore-based to ship-based training. In summary, innovations range across content of instruction, instructional procedure, student selection, and generation and implementation of training requirements.*

The initial ETAM study developed a complete set of manual procedures, parameters and formats for all analysis, synthesis and decision. A comprehensive, descriptive taxonomy of educational technology was generated. Its purpose was to enable any proposed innovation to be described in a standardized terminology for determining the full range of potential effect in the Navy: students, courses, jobs, instructional devices, instructional development, as areas of relevance. An equivalent effort was spent in developing or adapting analytic cost models applicable to the Navy's training environments.

The procedural model also included return on investment analysis, sensitivity analysis, and scaling procedures for translating subjective evaluations of

* For additional reference to educational innovations see: Miller, Robert B. and Duffy, Larry R., 1975. Design of Training Systems Phase II-A Final Report. TAEG Report No. 12-3, Training Analysis and Evaluation Group, Orlando, FL. Chapter III.

relative worth into utility values. These utility expressions became inputs to formal decision tree models to be presented to the executive decision maker. A logical flow of information is maintained from one procedural step to the next, so that the assessor can readily review the sources of benefits data, cost data, judgments and assumptions leading up to the final presentation of evaluation decision alternatives. The decision maker can change the input values to the sensitive parameters in the model and determine the effect on the decision alternatives. The decision maker is not restricted to working only from the formal outcomes of staff evaluations.

ASSUMPTIONS ABOUT USING THE MODEL

Some assumptions that were stated in the initial ETAM study should be repeated here.

1. The primary user of ETAM will be the assessor of the innovation. He (or the assessing team) have expertise in the subject matter of the particular innovation to be evaluated. He has mastered the ETAM classification structure, at least to the level of being able to reference its content. Furthermore, he will have had at least several dozen hours of preliminary practice in applying the procedures manually (except for calculational problems) and can "walk his way through" the major ETAM tasks. He will also have background in the operational aspects of Navy training courses, instructional devices and media, Navy jobs, and/or the developmental stages of training; at least he will be familiar with those aspects of these operations relevant to the innovation. This assumption recognizes that humans will provide the information inputs and judgments, whereas the model merely structures, guides, and within defined limits processes them.
2. The secondary user of ETAM will be the executive decision maker. He makes the decision to commit, deny or commute the resource for implementing the decision. He may question the constituent or summary judgments, evaluations, data sources and predictions of the assessor embodied in the final evaluative recommendation. He can "peel back" the various layers of data and judgements entering into the final calculations. ETAM documentation should facilitate this normal relationship between the executive and his advisory staff work. The service of the computer should aid rather than hinder this inspection.

A key factor is the ability to identify the factors most sensitive to the decision outcome, and test the range of this sensitivity across the limit where a recommended decision choice A changes to a decision choice B.

3. The assessor will make the final judgments as to whether the innovation is or is not applicable to an entity such as a given training course, a given instructional vehicle, a given

job or job-task. The range-of-effect search operations, including the indexing of the innovation and indexing the data base content, and automatic searches on data bases, will facilitate those judgments, but not replace them.

4. The user is not compelled to apply the procedures beyond any stage where common sense shows that the outcome will be hopelessly negative. The model is segmented into stages so as to help this kind of efficient termination come about. It is easy to become disengaged from the model with a sensibly completed piece of work. The assessor is also encouraged to examine the outcome of each stage of work for being within the bounds of reasonableness.

OBJECTIVES FOR ETAM

The design phase of ETAM led to the specification of a set of manual procedures for assessing a proposed innovation or change in Navy training. A proper follow-on objective was adapting computerized aids for reducing the large burdens of manual activities and supplementing rather than replacing or interfering with human judgmental processes. The scaling operations leading to expressions of utility in decision models were so important that they deserved intensive study of theory and practice in behavioral utility models before adopting and standardizing on any given procedure. Another key issue was the practicability of the ETAM classification structure to the indexing and searching of the content in Navy data bases dealing with training courses, jobs and job-tasks, instructional vehicles and media. These issues were the basis for the next phase of ETAM.

The following tasks summarize the initial ETAM objectives:

1. A study to determine appropriate scaling techniques which would increase the expected reliability and validity of subjective estimates required within the ETAM procedures.*
2. A study to define indexing methods to provide equivalence between the ETAM range-of-effect taxonomic elements and data base descriptors for the purpose of achieving effective data search and retrieval operations.**
3. A major report presenting a comprehensive overview of the innovations in concepts, methods and practices that have shaped and are currently influencing modern instructional technology. The purpose was to give the intelligent layman an overview of the effects of innovation upon training. Such a document would aid high-ranking military officers and business executives

* Miller, Robert B., and Duffy, Larry R., 1975. Design of Training Systems, The Development of Scaling Techniques. TAEG Report No. 32, Training Analysis and Evaluation Group, Orlando, FL.

** Refer to Appendix A of this report, TAEG Report No. 40.

TAEG REPORT NO. 40

in making decisions on applying proposed innovative techniques and/or technologies to their training system. There are parallels, but few direct equivalents, of the content of the initial ETAM report (TAEG Report No. 12-3). It would be an appropriate orienting background to the ETAM report for those using its content.*

4. Computerization of the ETAM logic so that an assessor can interactively arrive at an accept/reject conclusion using various utility, probability, cost and benefit data as model inputs. Standard program documentation and a user's guide will be produced as an output of this task.

* Miller, Robert B., and Smode, Alfred F., 1976. Major Innovations in Training Technology. Training Analysis and Evaluation Group, Orlando, FL.

SECTION II

ETAM FUNCTIONAL REQUIREMENTS

This section of the report has two components. The first deals with the procedures arising from the steps in the operational sequence of ETAM. Each of these steps has a set of defined information inputs, processing activities, and defined information outputs. This procedural definition was presented in the initial ETAM report, but subject to modification by the results of the studies on scaling and on indexing procedures. The second component of the functional requirement is the design requirement for computer support to the procedures.

PROCEDURAL REQUIREMENTS

The ETAM procedures consist of eight major tasks. The following descriptions will focus on the data management components of these tasks rather than on how they are performed since these aspects are most relevant to the functions of computerized data storage, processing and retrieval.

Figure II-1 is a schematic of these steps.

TASK 1 - FORMALIZE THE DESCRIPTION OF THE INNOVATION. A project file is initiated to serve as a data base for Innovation X. The innovator identifies the objectives of the innovation as he conceived them, target applications, and the results of empirical studies, if any, made from the innovation, or cited as relevant to the innovation. With the assistance of a staff "assessor" with ETAM background, the prose description of the innovation is indexed according to the taxonomic classification descriptors in ETAM. The indexed innovation as a set of descriptors will be used as a search specification against data bases in Task 5--determination of range-of-effect. The information in prose form will be retained in a Task 1 file.

TASK 2 - DEVELOP/EXAMINE ALTERNATIVES TO THE INNOVATION. In this task the innovator (or other expert) is requested to consider possible alternatives to the proposed innovation which may require a lesser level of investment funding, and possibly be more cost effective. Any outcome of Task 2 will be treated procedurally like Task 1 and the outcomes of Task 1. The ultimate result will be to create a decision that compares Innovation X with the alternative Innovation XX. The profile of descriptors that indexes Innovation XX may, or may not, be identical to the index of Innovation X. Innovation XX will generate its own file with a direct associative link to Innovation X.

TASK 3 - MAKE PRELIMINARY FEASIBILITY PROFILE. The formal assessment procedure begins at this point with a questionnaire about potential risks in the implementation, acceptance and application of the innovation. The issues deal with organizational incompatibilities, goal/policies incompatibilities, technical support requirements, funding constraints and problems in attitudinal acceptance by users. A format is available for entering risk estimates and comments on each of the key risk variables.

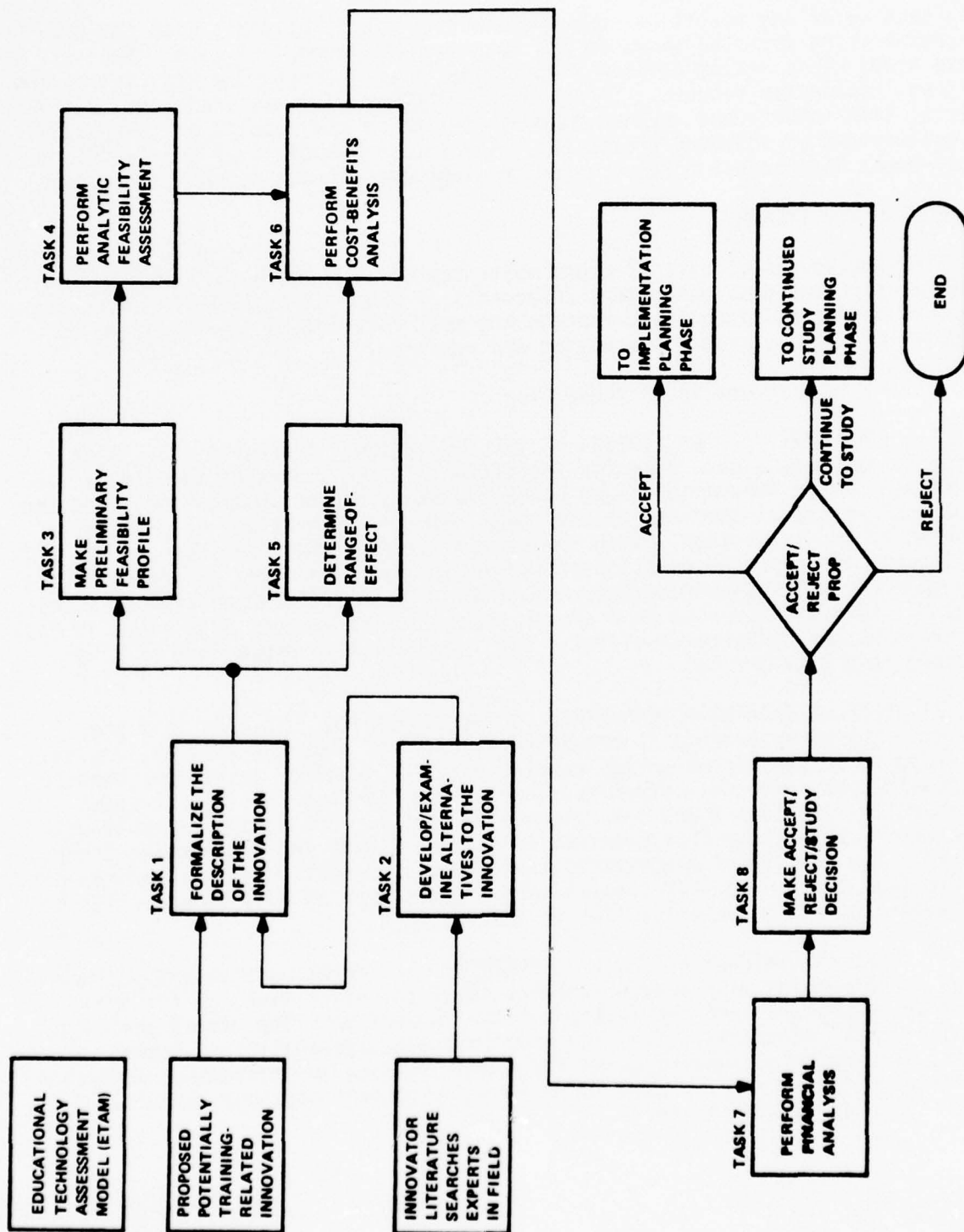

FIGURE II-1. ETAM PROCEDURAL SEQUENCE

If the risks are high, risk reduction projects are formulated. Their costs are roughly estimated and the consequent risk reduction is also estimated. If the overall risks still seem excessively high, the decision to reject the innovation from further consideration may be made at this point.

A format for collecting these data is contained in Appendix B of this report (Figure B-1). The content becomes part of the Project File. It will be used in Task 4 and appear as essential data in Task 8.

TASK 4 - PERFORM ANALYTIC FEASIBILITY ASSESSMENT. The results of Task 3 are analyzed in greater depth and risk reduction studies and projects are further defined and costed. A preliminary decision tree is structured for providing initial guidance as to whether the innovation should be accepted outright, accepted with the additional expenditures for the risk reduction projects, or rejected. Presumably, a definitive range-of-effect study of potential benefits has not yet been justified, or a sample of already known target applications for the innovation is a sufficient working basis for this stage of assessment.

Project descriptions are prepared for each R&D effort with supporting data about resource requirements, cost analysis, and time schedules. These projects are grouped into packages, each of which is intended to reduce the overall risk to a reasonable level. A format for collecting cost/saving data is shown in Appendix B (Figure B-2).

Decision trees are developed from estimated benefits data, cost data associated with various supplemental projects, and risk estimations. Refer to Appendix B (Figures B-3 and B-4).

Note that at this stage, the range-of-effect and cost analysis has been only grossly estimated rather than derived from a full scale analysis. But even on these bases, the differences among the decision alternatives may be so large and, based on sensitivity analysis, appear so reliable, that a decision may be justified without further analysis.

If analysis proceeds further, the risk estimations and risk reduction project data are fed into Task 6.

TASK 5 - DETERMINE RANGE-OF-EFFECT. The prior tasks have been concerned with the assessment of the innovation over a limited range of application. Initially, it was the target applications identified by the innovator; in Task 4 a preliminary extended range-of-application was considered. Task 5 enables the assessor to apply both the formal descriptors applied to indexing the innovation and the contextual knowledge about the innovation to the full range of the Navy's inventory of training courses, instruction vehicles and job-tasks.

ETAM stipulates that entities--training courses, job-tasks, instructional vehicles--subject to range-of-effect analysis may be indexed according to the rules of the descriptor taxonomy in ETAM formulated in Appendix A of this report. These indexed entities comprise a data base. This data base can be searched by search arguments composed of the descriptors that uniquely identify the relevant properties of the innovation.

Thus, the indexed description of the innovation that was made in Task 1 becomes an input into range-of-effect search. When the search arguments reveal hits in the data base, the assessor examines contextual information about the entity (a course, a job-task, or an instructional vehicle) and makes a judgment of relevance or irrelevance. When matches between the innovation's properties and the entity's properties are made, the assessor estimates the kind and proportional magnitude of benefit/liability that is likely to be contributed by the innovation. A method from the initial ETAM study for describing a benefit (or liability) is shown in Appendix B (Figure B-5). Ordinarily, there will be a number of benefit variables and liability variables that make up a pattern or profile applicable to the innovation's promise. The identification of affected entities (courses, etc.) is input to cost-benefit analysis, Task 6.

TASK 6 - PERFORM COST-BENEFITS ANALYSIS. The decision tree developed in Task 4 is refined to include more precise costs and savings derived from processing the tangible benefits through the model. Thus, if the innovation has been estimated to enable an average reduction of 20% for learning the content of Course A to criterion, the cost model determines how frequently the course is taught, how many students take the course and, from its base of cost data about Course A, computes in dollars the actual projected savings. In addition, the assessor uses utility scaling techniques for analyzing intangible benefits so that they are expressed in "equivalent dollars," thus enabling them to be combined into a single continuum of worth or value. Equivalent dollars is a utility expression rather than a literal dollar value. Probabilities of implementation success and user acceptance with and without the risk reduction projects are refined and the decision variables are recalculated.

The procedural model described in the ETAM Phase II-B report, "Design of Training Systems, The Development of Scaling Procedures," is the structure whereby the assessor generates multivariate utilities for outcomes in the decision tree.

The model permits sensitivity analysis of variables that could reasonably change enough to affect the choice of a decision alternative.

The output of this Task goes into Task 7, and subsequently to the decision maker in Task 8.

TASK 7 - PERFORM FINANCIAL ANALYSIS. This task is concerned with assessing the tangible benefits and liabilities (those expressible in real dollars) in terms of certain economic measures. The investment costs and the annual costs and savings are calculated over a planning period extending a number of years into the future. Rates-of-return on the invested dollars are determined for the incremental effect of each alternative compared to the primary project. Alternatives consist of the proposed innovation, the existing system, and any other approaches defined in Task 2 which were considered reasonable candidates for further assessment. This assessment process provides a separate, distinct view of the value of the innovation from that gained from the decision tree assessment in Task 6. Both are inputs to the decision maker.

The model enables sensitivity analysis. The purpose is to give the assessor insight into the variables that could cause a change in the decision if they were to vary over a reasonably expected range.

TASK 8 - MAKE THE ACCEPT/REJECT/STUDY DECISION. The immediate bases for the making of the decision are the financial analysis, plus sensitivity analysis, from Task 7, and the decision tree data, plus sensitivity analysis, from Task 6.

However, the organized content of the data base files of the assessment project enables the decision maker to examine any of the constituent elements beneath the summary presentation made to him. He may substitute his own evaluations of worth, probability of outcomes, importance of intangibles, estimates of benefits or liabilities. He may "peel back" the data in each of the seven tasks by selectively accessing the files on each of these tasks. He could examine samples of range-of-effect entities contained in computer files and retrieved interactively.

The executive is thus in a position to put probes behind the facade of conclusions presented to him. He is therefore capable of reassurance in the results or direct participation in changing them according to his own values and store of information.

COMMENT. The preceding description is merely a synoptic outline of the ETAM procedure. It is neither a substitute nor replacement for the full description, including stipulations, assumptions and caveats, that are contained in the source, the initial ETAM report, TAEG Report No. 12-3.

DESIGN REQUIREMENTS

The Education Technology Assessment Model as outlined in the previous section is an organized grouping of procedural sequences that provide a structure for efficiently and effectively assessing the true value of a proposed innovation in training. Efficiency is, however, highly dependent upon the assessor's ability to access data when required, rapidly make calculations using selectable routines (e.g., Training Cost Model), modify input data and make recalculations, and obtain output reports with suitable content and format for effective analysis and decision making. An efficient assessment processing structure requires:

1. Organized data bases external to ETAM with rapid search and retrieval capability.
2. Automated routines which can be selected at specific stages of the assessment process for making calculations or manipulating data.
3. Project files which will serve as a repository for:
 - Descriptive data on the innovation.
 - Input data factors.
 - Results of data base searches.
 - Intermediate calculated results.
 - Implementation subproject descriptive and cost data.
 - Final analytic results.
4. An organized system of manual and computerized steps that will make it possible for the trained user to select prudently the sequencing of data retrieval, data manipulation, calculations, interactive requirements, and output generation based upon the analytic needs at a particular phase of the assessment.

TAEG REPORT NO. 40

OVERALL SYSTEM OBJECTIVES. The user is a major concern in the development of any complex interactive automated data system. The following objectives are intended as overall guidance to the development process to ensure a high level of user orientation is achieved.

1. Operational Ease.

There will be minimal requirement that the ultimate user be familiar with both the software and hardware design in order to solve his problems using the system. This implies an interface with the computer in a language which is presently within the user's repertory, and sufficient prompting and assistance to promote simplicity in problem entry as well as in output interpretation.

2. Interactive Capability.

Much of the data entry initially will be in batch form; however, once the basic analytic process has begun, a high degree of user interaction will be a part of the overall design structure. The user will be able to specify solution formats, to modify and override existing data, to call upon specific calculation or data manipulation routines, or to specify output report formats. The assistance provided the user through on-line prompting will be sufficient to permit rapid convergence toward problem solution and decision.

3. Modular Design.

As the user undertakes the assessment process, additional calculation and data manipulation requirements may be identified. The software system will be designed in such a way that existing routines can be modified or deleted with minimal impact on the other components of the system and so that additional routines can be developed and incorporated as a new module within the existing system framework. This facility is necessary to maintain a "general purpose" character to the assessment process, so that analytic processes unique to assessing certain types of innovations can be added as they are identified.

4. Data Base Maintenance.

Several data bases have been identified to interface with the ETAM programs. The intent is to access existing Navy data bases, insofar as is possible, so that existing data base maintenance approaches can be used. The objective is to minimize the amount of additional data to be collected and stored.

ETAM AUTOMATED DATA SYSTEM FUNCTIONAL DESIGN. The automated data system is designed with five major functions to control the flow of data and sequence of calculations, as well as provide input data paths to the data bases. The interrelationships between these five functions and the data bases are shown in Figure II-2. Following are descriptions of each function and the types of programs or subfunctions which may be contained within them. Specific programs and file structures developed to fulfill these functions are detailed in Section III of this report.

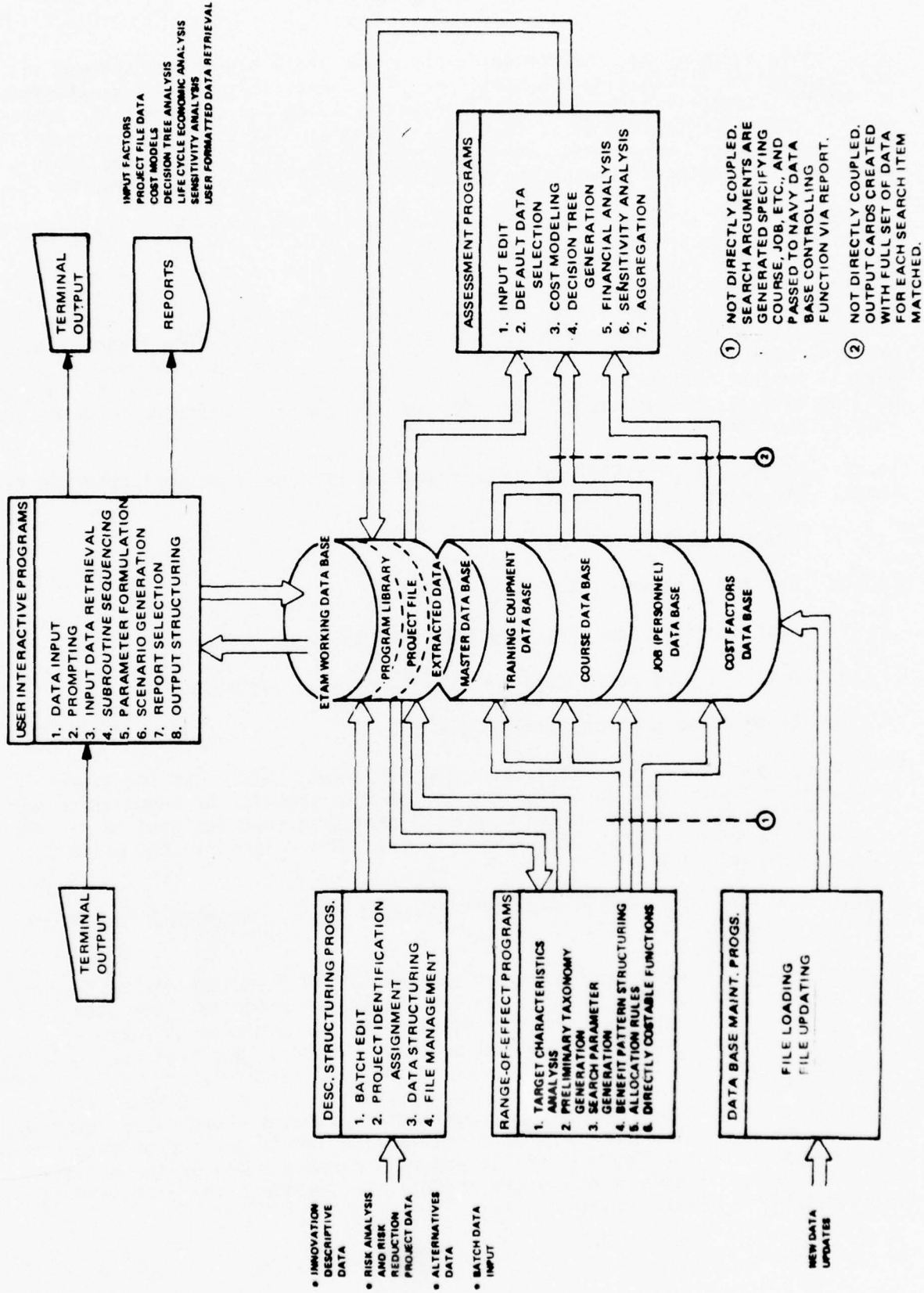

FIGURE II-2. ETAM STRUCTURE

Description Structuring. Source descriptive and project data are entered via the Description Structuring programs. Project identifications are established to ensure traceability throughout the entire analytic and data transfer process. Overall data structuring, as it relates to the organization of the project file data base, is performed here. Any batch data input (e.g., cost model input parameters) is entered through one of the Description Structuring programs.

Objective: The Description Structuring programs (DSP) establish a new project region within the project file section of the ETAM Working Data Base. They accept the total range of descriptive data on the new project (proposed training innovation) and format it for subsequent processing. They also accept major data subsets associated with the project which will include: (1) experimental studies with descriptions and resultant data, (2) risk reduction implementation projects with descriptions, resource requirements, schedules, and impacts upon overall project success, (3) alternative project descriptions, and (4) unique costing data. Input to the DSP will define the initial processing sequence and output requirements.

Input: Project file initialization and most updating will be performed via card input. The major input sets will be:

1. Project descriptive data.
2. Benefit pattern data.
3. Risk profiles and risk reduction project data.
4. Decision tree parameters (outcome scenarios, variables, etc.).
5. Alternative projects descriptive data.

Processing Functions: The DSP will accept input data sets. The required file management routines will be called and assigned to process the input which may be new data or replacement data. Once data sets have been assigned, a project table will be created which identifies all data sets related to the primary project being proposed.

Output: The major DSP output are the individual files created within the projected data base.

Range-of-Effect. The purpose of these programs is to formulate the processing pattern which is to form the input for the Assessment Programs. The user is to be provided preliminary guidance in preparing the taxonomic descriptors which will be used to search out the innovation's full range of application. Once the search characteristics have been defined, either interactively or off-line, the specific search parameter for the equipment, course, or job data bases are generated. The ETAM abbreviated data base which contains abbreviated records for Navy courses, jobs, etc., and user interactive inputs are the primary source of data upon which the Range-of-Effect programs operate. Any of the entities extracted through a data search operation will be passed to the extracted data base for further manipulation.

Objective: Primary objectives of the Range-of-Effect programs (REP) are (1) to create the necessary set of data base search parameters for obtaining the entities (e.g., course, jobs) to which the innovation has potential application, and (2) to structure the benefit pattern used by the Assessment function in calculating the decision variables.

Input: Project descriptive data from the project file will provide the target applications for the proposed innovation. This will establish the initial descriptor content. Benefit estimates and the empirical data will define benefit patterns and allocation rules for further modifying the search parameters.

Processing Functions: The appropriate abbreviated data base may be searched based upon the target application and the descriptor index will be presented for the review of the assessor. A conversion table will translate numeric indices to appropriate elements of the taxonomies related to the entity class for the target application. User Interactive programs (UIP) will prompt the assessor and select taxonomic menus to guide this refinement process. Multiple indices may be developed if improvements of the taxonomic menus are OR'ed together. Once the descriptor indices have been formulated, the appropriate abbreviated data base will be searched to obtain all entities which match.

Allocation rules are for the purpose of further refining the list of selected entities. For example, if courses having a length of one week or more can benefit from the proposed innovation, this would become an additional selector factor when the list of entities is forwarded to the Navy data base controlling function for extraction of the full range of attributes associated with the entities. The assessor must determine if the additional selectors are to be used to limit the number of entities extracted or whether they should be applied to the total set of extracted entities once they have been loaded in the extracted data section of the ETAM Working Data Base. This determination would be based upon whether the entities eliminated by the selector would ever be brought into the Assessment program analysis from a change in allocation rules.

A final processing function of the REP is the formulation of the benefit pattern used to input various routines with the Assessment Program. The ETAM procedures for Tasks 4, 5 and 6 should provide sufficient guidance on the content and format. Some benefit patterns will involve directly costable functions (i.e., straight displaceable costs) such as in the case where equipment is eliminated or replaced.

Output: The Range-of-Effect Program develops an output report containing a list of entities and selector factors to be used in searching existing Navy data bases to obtain the full attribute set for each entity matched. The second output will be a table of variables, degree of change, importance, confidence, etc., which will represent the benefits pattern to be used within the Assessment Program. Allocation rules which were not used in generating selector factors on the entity extraction tape will also be stored for use by the Assessment Program.

Assessment. The Assessment programs perform computational steps in the analytic process. This encompasses four basic types of computational capabilities; namely, cost models, decision tree evaluators, financial analysis routines, and

sensitivity analysis routines. In conjunction with these computational routines, basic input editing and default data selection functions are carried out by the Assessment programs. These routines will communicate with the user to identify additional data requirements, or to point out the characteristics of particular default data being used. Final results will be retained in the ETAM project file for additional processing or modification if desired. An aggregation routine will provide the means of summarizing the data from multiple selected entities (e.g., jobs), so that the computational routines can be run on aggregated data.

Objective: The Assessment programs (AP) provide the data manipulation and computational capability for generating costs, benefit quantities, decision variables, and sensitivity factors. These become the key inputs to the decision maker. The AP will have the capability of aggregating and weighting entities either for inputting cost models or resulting from processing by a cost model. Decision variables calculated on aggregated data will be obtained from either a cost-benefits analysis using a decision tree framework or from a financial return-on-investment analysis.

Input: Control instructions from the User Interactive programs (UIP) will guide the processing sequence for the AP; thus, the input factors selected will be a function of these instructions. Each routine (training costs model, job cost model, decision tree generator, etc.) will require a set of data variables which will be stored in the extracted data section of the ETAM project files. Each routine will also have provision for input editing and for the generation or selection of default data in the cases where information is missing.

Processing Functions: The processing design was guided by the initial ETAM study procedures for cost-benefits analysis and financial analysis. The processing routines within the AP are:

1. Training Cost Model

The basic logic of a Navy model developed for costing training requirements as a part of TECEP (Training Effectiveness/Cost Effectiveness Prediction Technique)* was incorporated into the Training Cost Model specified for ETAM. Several additional features to be incorporated into the final developed program outlined in Section III of this report are:

Extensive input data editing and default data specification.

User selectable policies for equipment purchase and equipment depreciation.

Selectable output reports.

Output format design compatible with CRT display to facilitate any conversion from the present batch to an interactive system with display capability.

*Braby, Richard (Ed.D), Henry, James M., Parrish, William F. Jr., and Swope, William M. (Ph.D), 1975. A Technique for Choosing Cost-Effective Instructional Delivery Systems. TAEG Report No. 16, Training Analysis and Evaluation Group, Orlando, FL.

2. Job Cost Model

The costing of job related impacts requires a manual analysis of the job/tasks affected by the innovation. Inputs can be in the form of frequency of tasks and time per task which can be converted to equivalent numbers of persons performing the tasks, or total persons impacted can be input directly. Other costs which can be estimated and inputted are:

Error rates and cost per error.

Support costs; e.g., tools, supervision, etc.

3. Equipment Cost Model

The "instructional vehicle" route in the Range-of-Effect Task 5 is taken when the innovation is concerned with a straight cost displacement effect. The data base accessed for obtaining attributes of equipments will contain cost. The model for determining equipment cost requires manual estimation of such items as:

Numbers affected
Equipment purchase cost
Purchase policy
Equipment maintenance cost
Life of equipment
Depreciation policy

4. Decision Tree Evaluator

The decision tree evaluation routine performs the necessary calculations required to fold back the tree and determine the value of the decision variable.

The inputs to the decision tree evaluation will be able to be entered directly in the batch mode or interactively through User Interaction programs. Inputs to this routine are:

Outcome utilities (equivalent costs)
Success probabilities
Risk package costs

5. Financial Analysis Routine

This routine performs a comparative return on investment analysis on the cost/savings effects of implementing the proposed innovation. Comparisons can be made between the primary proposal and the existing system, between the primary proposal and any identified alternative proposals, and between any two alternative proposals. The present value of each comparative investment is calculated based on an inputted discount rate. A Savings Investment Ratio, Rate of Return on Investment, and Uniform Annual Cost/Savings are calculated for each comparison.

6. Sensitivity Analysis Routine

Two sensitivity analysis routines are required. One is used with the decision tree where the decision variable is evaluated for its sensitivity to each variable included in the tree outcomes (A through D), to the success probabilities, and to the risk reduction package(s) cost. As is outlined in the initial ETAM procedures, the results of the sensitivity analysis will be:

Break-even value
Decision change (from/to)
Sensitivity factor
Probability factor

The mean value and confidence range for each variable are the inputs to the sensitivity analysis routine.

A second sensitivity analysis routine (actually to be developed as a subroutine of the first) will treat rate-of-return and present value decision variables as the dependent variables, and will allow a sensitivity calculation to be performed using each benefit variable and discount-rate as independent variables.

7. Aggregation Routine

The assessment program has the facility for summing the results of evaluating multiple entities. For example, if the innovation impacts fifty courses, each course would be processed through the training cost model, and the results aggregated through this routine. Similar aggregations would be performed for jobs, equipments, etc.

Output: The AP routines generate output data sets which can be accessed by report selection and output structuring routines. The specific report formats are outlined in Section III of this report.

User Interactive. Many of the ETAM software elements will require initiation via user on-line terminal control. The programs are "interactive" in the strict sense that user input is required to determine course of action, operational modes, etc. The user input will be prompted when required. Some programs are capable of producing a variety of output reports. The selection of report format and, in some instances, the amount of data to be included in the report will be provided by the user via terminal input. In certain routines, such as the decision tree evaluation, interaction with the user may be highly desirable in formulating parameters or in generating the scenarios required for each decision tree outcome.

Objective: Interactive control allows the assessor to maintain control over processing functions and input and output both batch and interactive. Such control extends to program control and maintenance of the ETAM data bases. To be implemented will be interaction with the assessor to perform editing, general prompting, data retrieval, and output formatting.

Inputs: Inputs to those processing functions which would normally require user-supplied input will be in many instances supplied by two sources. Within the executive control language of the system which calls the processing functions,

default execution parameters can be supplied; these defaults can be overridden by terminal input. In some instances, final input to a process may involve a combination of terminal input commands and executive control defaults.

Processing Functions: User interaction will be required for the control of those functions which encompass the following ETAM activities:

1. Data input and data editing. Specifically, this function is performed for any processes which require data to be input from the terminal.
2. Prompting: A number of prompting routines, including assistance ("help") to the user, guides for the assessor in data input and retrieval, processing control and decisions, and output selection.
3. Output reporting: Many routines can supply a variety of distinct output reports. The user may command the type and, in some instances, the amount of on-line reporting to meet his immediate requirements. In some processes, both on-line (terminal) and off-line (batch) output may be selected.

Output: The major outputs are data exception reports from the data editing functions, prompting instructions to the assessor when operating interactively, and interaction log which provides a record of terminal requests, and standard output reports.

Data Base Maintenance. This is a collection of programs required to maintain the ETAM master files. They provide the facilities for initial file loading, limited editing, and for printer or terminal dump of the file contents. A similar set of maintenance routines will also be required for the ETAM individual project files.

ETAM WORKING DATA BASE. There are three major sections of this data base. Specific developmental implementation of these functional data base requirements are included in Section III of this report.

Program Library. The first section of the ETAM Working Data Base is a program library containing the major programs and routines to be called during the processing operations. The programs contained within this section of the data base will be:

1. Description Structuring
2. Range-of-Effect
3. Assessment
4. User Interactive
5. Data Base Maintenance

A direct access storage device will be used for storing all programs, routines, and subroutines which are a part of the program library, as well as for storing project data, conversion tables, abbreviated records of entities for search retrieval, and extracted data from Navy data bases.

Project File. The second major section of the ETAM Working Data Base will contain all project data loaded initially using the Description Structuring programs, as well as any additional data developed as a result of performing the ETAM operations. These data will include:

1. Project Descriptive Data (from Task 1)
2. Alternatives to the Innovation (from Task 2)
3. Risk Factors and Risk Reduction Projects (from Task 3)
4. Decision Tree Factors (from Tasks 4 and 6)
5. Range-of-Effect Search Descriptors (from Task 5)
6. Benefits Patterns (from Task 5)
7. Cost-Benefits Results (from Task 6)
8. Financial Analysis Data (from Task 7)

Exterior to the project files, abbreviated records of all courses, jobs, and equipment will be maintained as a part of the ETAM Working Data Base. These records will be appropriately indexed to permit search once search descriptors have been formulated.

Project data will utilize a non-hierarchical structure with fixed length records. Relationships between primary project data, alternatives to the primary project, risk reduction project data, and entities being costed and aggregated will be maintained through cross-reference information contained within certain project file types. The components of the project file are defined in Section III of this report. The initial ETAM procedures served as a guide in development of project descriptive data and risk reduction project data.

Extracted Data. The third section of the ETAM Working Data Base serves as a repository for the full set of data extracted from searches of master Navy data bases. These data will be maintained throughout the assessment operation and finally summarized and stored as a part of the project data. Individual data sets will be established for entities extracted from existing Navy data bases. Because of many of the attributes of courses, job, and equipments are subject to frequent change, once extracted they will be used for processing in relation to a single proposed innovation being evaluated. The entity will be repeated in a separate data set if it is related to more than one project. New extraction may be required if the analysis spans a substantial time period or if the entities are related to a major new program which is being subjected to frequent change.

MASTER DATA BASE. This set of abbreviated data files is accessible by all projects and will contain:

Course Abbreviated Data Base Structures. The primary use of the abbreviated data bases is for searching out entities which match the descriptors formulated through the assessor's analysis of the target application and interactive prompting using the taxonomies related to the entity class (e.g., courses). Figure II-3 shows a recommended structure for courses to be maintained with the project file area of the ETAM Working Data Base.

T A E G R E P O R T N O . 4 0

<u>FIELD NAMES</u>	<u>DESCRIPTION</u>
CDP	Course CDP Number
CIN	Course Identification Number
CST	Course Short Title
NOBC	Naval Officer Billet Code
NEC	Primary NEC Code
PC	Priority Code
RMS	Low-Order 3 Digits of RMS Code
TYCRS	Type Course
SVC	Service
MI	Method of Instruction
STCD	Status Code
STDTE	Status Date
TRAPS	TRAPS Indicator
TPC	Training Program Coordinator
ATTR	Attrition Rate
STBK	Setback Rate
CLEN	Course Length
CHRS	Total Contact Hours
CAOB	Cost per AOB

FIGURE II-3. SAMPLE COURSE ABBREVIATED DATA BASE CONTENTS

TAEG REPORT NO. 40

Job Abbreviated Data Base Structure. As with the course abbreviated data base, the job abbreviated data base will be used to search job/task entities which match descriptors formulated from the taxonomies for the job/task entity class. A recommended structure is outlined in Figure II-4.

Equipment (Vehicle Type) Abbreviated Data Base Structure. The inventory of equipments used within naval training would be maintained in the third abbreviated data base. Figure II-5 shows a recommended structure.

TAEG REPORT NO. 40

<u>FIELD NAMES</u>	<u>DESCRIPTION</u>
RATE	Rating/Pay Grade
JTASK	Job/Task Code
JNAME	Job/Task Name
CBIL	Cost per Billet

FIGURE II-4. SAMPLE JOB ABBREVIATED DATA BASE CONTENTS

<u>FIELD NAMES</u>	<u>DESCRIPTION</u>
SNUM	Federal Stock Number
DDEG	Device Designator Number
DNAME	Device Name
DCOST	Device Cost

FIGURE II-5. SAMPLE TRAINING VEHICLE ABBREVIATED DATA
BASE CONTENTS

T A E G R E P O R T N O . 4 0

T H I S P A G E I N T E N T I O N A L L Y L E F T B L A N K .

SECTION III

ETAM DEVELOPMENT

This section reports the achievements of the ETAM Phase II-B effort. Because full reports on the studies on Scaling and Indexing and the document on Innovations in Training are available separately, their contents will be merely summarized here.

PRELIMINARY STUDIES

SCALING PROCEDURES. The objective of this study was to develop procedures that were simple but psychologically reliable and valid for enabling an informed decision maker (or the staff supporting the decision maker) to express the combined subjective value scales in order to reach a single continuum of worth or "utility" on which to set and evaluate outcome alternatives. Real life decisions must often take into account more or less intangible variables such as "mission success," or "increased motivation," or "increased capacity for initiative." Attempts to convert these variables into objective dollar data, while useful, are inevitably incomplete expressions of the benefit (or liability) factors inherent in the concept of the variable in real world enterprise.

The study had to depend on the interpretation of the state-of-the-art in decision theory and behavioral utility theory rather than on independent empirical research. The activities therefore consisted of intensive search and review of an extensive body literature. Much of the literature is theoretically oriented towards mathematical models attempting to simulate human decision processes. Some of it is empirically and practically oriented towards giving the human decision maker better tools that minimize niceties that have little or no practical value but greatly complicate the mechanics of the procedure.

Rationales were developed for decision making in the ETAM context. These included a novel concept, the idea of a "system utility" continuum for the executive. The anchor point of this continuum was in the present. Another reference point would be the idealized level of the variable. Still another would be the projection of the location of the point on the variable into future states of the system, assuming no change in the process but changes in the system environment. The projected value of the innovation's contribution to the variable could then be located with respect to these reference points and evaluated. This concept shifts the focus of the decision maker from the classical self-serving basis for utility and choice into an enterprise-serving reference.

These and related issues became part of the instructional content in the study report, and are intended to supplement the procedural mechanics for utility scaling.

A set of scaling procedures consistent with ETAM requirements was developed. It can be performed manually, with paper formats, but more effectively with computer interaction. The user is relieved of a variety of paper-shuffling and computational mechanics, and can readily be refreshed with source data for making scaling decisions.

A major finding, almost a consensus, in the practical literature is that the simplest scaling procedures are as effective as the more complex. This finding was reflected in the ETAM procedure.

In order to maintain a common sense reference, as well as to be responsive to individual differences in assessors and decision maker preferences, the ETAM procedure calls for the global or wholistic (intuitive) method to be used as a check against the results of the "decomposition" or analytic method.

The final report on this study contains a step-by-step method for the scaling operations that establish the inputs for the decision tree content. The report also summarizes the literature that was examined, and contains instructional rationales for the user's orientation to decision making in the setting of an enterprise. It is not necessary that the user accept the premises and rationales, but at least there is a reference for departure from them.

The study personnel undertook some informal sample tests of the procedure in some mutual and simulated situations. It was found that the procedures are far easier to perform than to describe--multivariate scaling problems could be solved in ten to twenty minutes. The results conformed to retrospective common sense; that is, common sense applied after the procedure had yielded results. But the procedure took into account more information available to the user than appeared to be used in global or intuitional methods.

These are not definitive tests, of course. They are cited primarily to indicate that the procedures are not cumbersome to apply, despite the appearance of the formal presentation of the method.

INDEXING. An innovation or change may affect perhaps some 100 out of the over 4,000 courses taught by the Navy, or some half-dozen of the hundreds of Navy instructional vehicle types; or several hundred job-tasks in the tens of thousands of job-tasks scattered across Navy rates and ratings. The hard way of finding the targets would be to read through the entire catalog of course descriptions in Catalog of Navy Training Courses (CANTRAC), or the huge Occupational Standards directory and Navy Occupational Task Analysis Program (NOTAP) listings, or several thousand pages of descriptions of the Navy's instructional devices.

The easier way would be to attach subject matter descriptors to each of the entities in these inventories of items; index the particular innovation from the same set of descriptors, and use this index as a search argument; then, enter the search argument into a computerized search for matching entities. This would yield at least a preliminary set of candidate entities relevant to the innovation. Final decisions of relevance would require the human to scan the context information about the entity such as job-task titles and descriptions, course descriptions, or instructional vehicle descriptions. But the latter task could be confined to a manageable subset of the total inventory.

The first phase of ETAM developed a taxonomic structure for job-tasks, course objectives, and instructional vehicles. This classification aimed at identifying essential attributes of the teaching-learning process and its supporting

elements. One objective of the present study was to try out this classification scheme by indexing samples of each of the three inventory types (courses, job-tasks, vehicles) to determine indexing feasibility. The second phase of this demonstration was to create a data base structure for automatic search with sample descriptor-indexed innovations. A second objective was to formulate overall strategies, not limited to the automatic phase of convergence, in determining the full range-of-effect of a proposed innovation. These strategies of necessity would have to compromise the ideal with the practical. The third objective, growing out of the first, was to demonstrate at least a limited tryout with an interactive computer procedure for entering a search specification and receiving processed output. The results of the study consisted of a report on recommended indexing procedures and search procedures and demonstrations of interactive computer processing. (See Appendix A.)

A paper format was prepared for indexing training courses from CANTRAC course descriptions. The total descriptor set was about 50 terms, grouped into less than a dozen categories. They were taken directly from the ETAM taxonomy. The indexer was highly familiar with the meanings of these descriptors and had some general background in the content of training courses. After several hours of practice, the indexing task, although difficult, was not overwhelming. Up to 15 courses could be indexed in an hour. This pace could accelerate when a given type of course could be identified and matched with a fairly standard pattern of descriptors. The same experience applied to indexing job-task titles in the context of rates and ratings in the Occupational Standards directory, except that a faster pace could be maintained. The more specific the description and the clearer the context, the faster and more certain the indexing activity can be. The quality of descriptions of training devices and their application was highly variable, and this created greater uncertainty in many cases in the selection of applicable descriptors.

A key factor that enabled coping with ambiguity in selecting descriptors for an entity was recognizing that the final selection of relevant entities would not be restricted to automatic search, but to human examination of contextual information about the entity. This means that automatic search should result only in excluding from further examination those entities with high probability of low yield. The indexer's policy therefore was, when ambivalent whether or not to apply the descriptor to the entity, to apply it. This may later add an increment of labor to the human in culling it out manually. But if the descriptor was, for later range-of-effect determinations, applicable, the entity would not be lost for inclusion. This policy was also incorporated into recommendations for indexing the innovation.

The human assessor may choose to bypass the ETAM level of search and go directly to the applicable Navy data base of courses, job-tasks or instructional vehicles. The coding of job-task titles in the Occupational Standards embodies a secondary subject matter index. Occupational Standards listings are computerized, and their contents can be selectively retrieved, some interactively. The listings are also tied into the computerized NOTAP data which provide extensive context information about each job-task listed in the Occupational Standards. Whereas ETAM descriptors are limited primarily to

task "functions," the NOTAP descriptions include tools and equipment used, importance and frequency of the job-task, and other significant details. They also reference the Navy courses where the requisite skill is trained.

With very minor modifications, and within the limited range of practical testing applied thus far, the ETAM taxonomy adequately serves the indexing and search functions. The fact that the descriptor set applied to each of the three classes of entities is restricted to about 50 items, grouped into meaningful subsets, is a substantial advantage--the entire set can be displayed on a single page and scanned in a few moments.

REPORT ON MAJOR INNOVATIONS IN TRAINING TECHNOLOGY. The objective of this report was a readable and interesting document about changes in training technology during the past 25 years. The target audience consisted of executives and their staff in the field of education and training, as well as specialists with a need for overviews and background. Emphasis was to be placed on concepts and doctrines underlying the innovations as well as the essential features of the innovations themselves. It was to be a comprehensive overview rather than a detailed catalog. The preparation of the report was a collaborative effort between Dr. Alfred F. Smode of the Navy Training Analysis and Evaluation Group and Dr. Robert B. Miller of IBM.

The content of the document is not readily summarized in a few paragraphs, but several major topics can be identified. An evolutionary change is shifting training doctrine from teaching about a subject matter to the learning of skills and competences. Information about the learning process and about individual differences becomes integrated into "learner-centered" instruction. Understanding about tasks and skills is reflected in clearer definitions of training objectives and performance criteria, with improved payoff. Models of tradeoff variables in training and learning--such as motivation and native ability as examples--permit greater flexibility and more economical practices. New social and psychological models of work and the worker can and should be reflected in the conditions of learning.

A tighter and therefore more economical coupling is being developed in the sequence of technical activities that begins with the need for a new skill; the identification of the components of that skill; the preparation of means for selecting, training and evaluating the learner; and his assignment and evaluation on the job.

The computer is playing important and diverse roles. It is central to the control of wide ranges in type of instruction from the format of programmed instruction to the realistic simulation of entire aircraft missions from startup to shutdown. It enables, at a cost, the highly realistic performance of the properties of the vehicle operating under the management of the student operator in a wide range of environments. But in addition, the computer is a powerful extension of the instructor in measuring and evaluating behavior, in changing the level or kind of problem the student has to solve, and in giving guidance. The instructor becomes a manager of instruction rather than a mechanic who manipulates the devices of instruction. But the training capability of the device is nonetheless limited to the instructional purposes and designs to which it is put, and these depend on human insight and competence.

The Navy's training organization is a vast enterprise, with inventories of thousands of courses, instructors, students, devices, and other resources. The control and management of this enterprise requires increasing dependence on the computer and computer models for scheduling resources in coping with complex and changing demand patterns and varied pipeline inputs. Both budgetary and time constraints demand effectiveness in operation with high levels of efficiency. But computer operations demand a variety of standardizations in operation that may conflict with flexibility for the needs at the moment. The significant innovation is the interactive computer that enables the human to intervene in the operation or decision which is standard for the computer program and to modify its output, but doing so with a display of the consequences of his action before they actually occur. The computer program, thus, becomes a tool to human judgment in the situation of the moment.

Telecommunications around the world make it increasingly feasible to put training where the student happens to be rather than having to bring him to the classroom. This capability will be supported by decreasing costs and miniaturization of computers. It can be anticipated that learning and doing will become more intimately related in the job environment itself. This will be another innovation made possible by engineering technology and by possibly radical changes in the concept of job competence and its relationship to the learning-training process.

The foregoing are samples of some ideas that thread through the document. The structure of the report contains several levels of summarization. An early chapter embeds one level of summarization. Each chapter has its own summary.

ETAM PROGRAM FLOW

ETAM consists of a sequence of data collection, data input, data analysis, interactive data refinement, computational, and data output steps. The system is designed to perform on the National CSS timesharing system. The user interacts with the system in three basic ways.

1. ETAM is run interactively with the user specifying certain processing sequences, data inputs, and output requests in a real-time mode.
2. User project files are created or updated in batch mode via card input shipped to a National CSS processing center; e.g., Atlanta, Georgia. Similarly, the batch mode of operation can be used for processing the more voluminous output reports which will be run at the National CSS processing center and shipped to the user.
3. System data bases accessible to each user (and project) are generated, updated, or printed through system generation/data base maintenance routines which are part of the main ETAM process flow.

This section describes the major data sources which support the ETAM processing sequence. The basic model processing steps are also described. Programming development has been completed through the Range-of-Effect part of the ETAM processing sequence, therefore, the data files and processing steps described for Range-of-Effect reflect the operational system. The Assessment part of the ETAM processing sequence has been completed through the program design

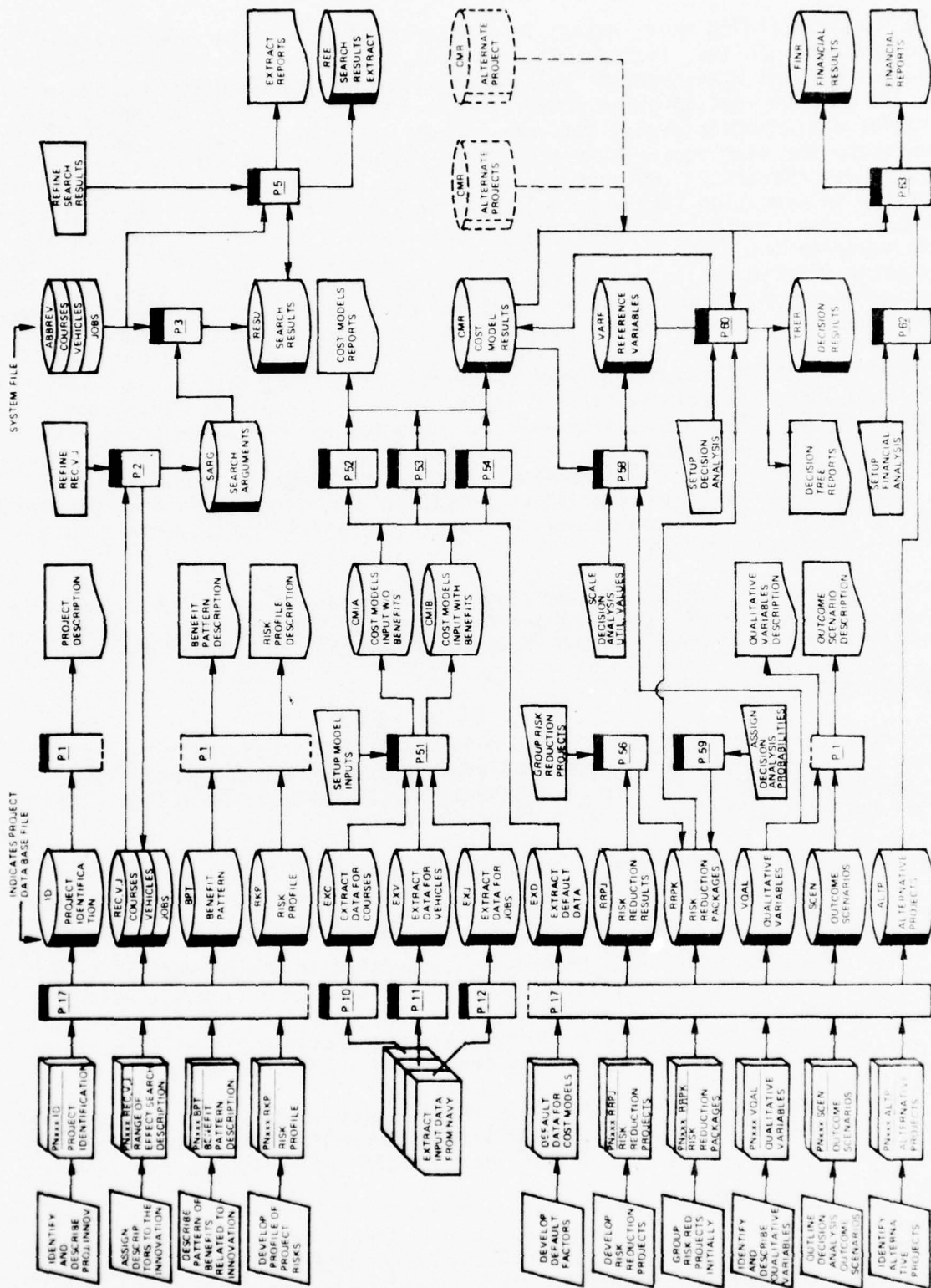

FIGURE III-1. ETAM PROGRAM/DATA BASE FLOW

level, therefore, the documentation of that process provides detailed specifications and design guidance for completing the ETAM program development. Figure III-1 shows the ETAM project data base files, programs, and their interrelationships.

PROJECT DATA BASE FILES. The Project Data Base (PDB) stores all initially entered, prompted, and calculated information for each project being evaluated by ETAM. Each project is assigned a unique file name (fn); e.g., fn = PN123, and may have up to twenty-two file types (ft); e.g., ft = ID, ft = SCEN, etc., associated with each fn. For example, the fn ft called PN123 ID will store the descriptive text for project PN123. The twenty-two file types which have been identified for each project are as follows:

ID (Identification). This file contains descriptive information on the project such as Project Name, Abstract, Objectives, Experimental Results, and Target Applications. The data are stored in 80-column card image format with major paragraph headings as identified in the examples above. Blank cards may be inserted freely to improve readability of output reports containing exact images of this file. The first card in this file must contain the file name; i.e., PNnnn anywhere in the first ten columns. Columns 11-80 will contain the Project Name. An example of the ID file content is shown in Figure III-2. It can be printed with the P1 print program.

REC (Range-of-Effect, Course). An innovation which has potential application to Navy courses will be described with one or more course-related descriptors. This file contains initial descriptors assigned by the assessor, or interim or finalized descriptors resulting from possibly several iterations of prompting, course searches, and analysis. Each descriptor number, with an associated sign, is placed anywhere in the first ten position of a card-image field. Descriptor names are not required as they will be inserted from a Course Descriptor file during processing. The negative descriptor number is allowed to perform a NOT logic function during the search operation. An example of REC file content is shown in Figure III-3.

REV (Range-of-Effect, Vehicle). Instructional vehicles may be affected by certain innovations. The innovation will then be described with vehicle-related descriptors. Format and use are the same as the REC file. Descriptor names will be obtained during processing from the Vehicle Descriptor file.

REJ (Range-of-Effect, Job/Tasks). Innovations which may affect certain job/tasks within the Navy will be described with job-related descriptors. Format and use of this file is the same as REC. Again, descriptor names will be obtained from a Job/Task Descriptor file and inserted during processing.

SARG (Search Arguments). This is a non-printable, internally generated file which provides a map of the REC, REV, and REJ descriptors for subsequent search of the Abbreviated Data Bases for Courses, Vehicles, and Job/Tasks. The file contains three 240-character records. The first record contains a map of the REC(Course) descriptors, two the REV(Vehicle) descriptors, and three the REJ(Job/Task) descriptors. The format of the SARG file is as follows:

PAGE NUMBER : 1

SOURCE CARD LISTING FOR
**ID

**ID
PN123 3-D PROCEDURAL TRAINER

OBJECTIVES AND SUMMARY DESCRIPTION

THE OBJECTIVE IS TO INCREASE THE EFFICIENCY AND RETENTIVITY OF THE LEARNING OF OPERATING PROCEDURES ON ELECTRONIC EQUIPMENT. THE DEVICE CONSISTS OF THE SHELL OF THE ELECTRONIC GEAR ON WHICH THE PROCEDURES ARE TO BE LEARNED. WITHIN THIS SHELL, SPECIAL CIRCUITS ARE HOOKED UP TO A COMPUTER WHICH SIMULATES THE BEHAVIOR OF THE EQUIPMENT TO THE ACTIONS OF THE STUDENT, BUT ALSO PROVIDES CORRECTIVE AND OTHER INSTRUCTIONAL GUIDANCE. THE COMPUTER IS PROGRAMMABLE SO AS TO ADAPT TO THE LEARNING OBJECTIVES.

DELIVERY SYSTEM

THE INNOVATION CENTERS AROUND A DELIVERY SYSTEM FOR PROCEDURES LEARNING. THE TRAINER REPLACES THE OPERATIONAL LIVE EQUIPMENT THAT IS USED FOR INSTRUCTIONAL PURPOSES AND THE INSTRUCTIONAL MANUALS THAT GUIDE THE STUDENT IN HIS LEARNING THE PROCEDURE.

INSTRUCTIONAL PROCESS

THE DEVICE ENABLES THE STUDENT TO PERFORM MANUAL PROCEDURES WITH ACTUAL DISPLAYS AND CONTROLS AND THEIR RELATIONSHIPS. HE ALSO GETS INSTRUCTIONAL FEEDBACK AND GUIDANCE FROM AN AUXILIARY DISPLAY SCREEN CONTROLLED BY THE COMPUTER. THE STUDENT ACTUALLY LEARNS BY DOING THE TASK, WITH SUPPLEMENTAL INDIVIDUALIZED HELP AND DIRECTION CONTROLLED BY THE RESPONSES HE HAS ALREADY MADE, AND SHOULD BE MAKING NEXT. THIS SHOULD RESULT IN FASTER LEARNING, BETTER REMEMBERING, AND HIGHER PROCEDURAL LEVEL SKILL. THE DEVICE IS A FORM OF SIMULATOR.

JOBS AND TASKS

OF PRIMARY RELEVANCE ARE THOSE JOBS THAT DEAL WITH THE EXTERNAL DISPLAYS AND CONTROLS OF INTACT ELECTRONIC EQUIPMENT. THIS MAY INCLUDE TEST EQUIPMENT AND OPERATOR TRAINING IN SEQUENTIAL PROCEDURES ON THE EQUIPMENT SUCH AS TURN ON, START UP, CHECKOUT, AND OPERATION. ALSO, MAINTENANCE TASKS DONE ON THE OUTSIDE OF THE INTACT ELECTRONIC EQUIPMENT SUCH AS CHECKOUT, ALIGNMENT ETC.

EQUIPMENT ORIENTATION

ELECTRONIC EQUIPMENT. NO RESTRICTIONS ON EQUIPMENT TYPE.

WORK FUNCTION

SEQUENTIAL PROCEDURES: READING INDICATORS; ACTIVATING CONTROLS AS PRESCRIBED IN SEQUENCE; RECOGNIZING DEVIATIONS FROM "NORMAL" AND TAKING SPECIFIED ACTION.

OPERATIONAL ENVIRONMENT

ANY LAB ENVIRONMENT: NO PHYSICAL MOTION; NORMAL TEMPERATURES. THE STUDENT IS UNSTRESSED EXCEPT AS MAY BE ARTIFICIALLY INDUCED BY VERBAL MEANS. SPACE USED BY THE TRAINER IS PRACTICALLY EQUIVALENT TO THAT USED BY OPERATIONAL EQUIPMENT FOR TRAINING.

STUDENT ATTRIBUTES

MAY HELP SLOW LEARNERS OF ROUTINE TASKS. STUDENT ATTRIBUTE FACTORS ARE NOT A MAJOR TARGET OF THE INNOVATION.

PRIOR TRAINING AND EXPERIENCE

THE TRAINER COULD BE AN EFFICIENT WAY OF PROVIDING REFRESHER TRAINING, BUT THIS HAS NOT BEEN INVESTIGATED AS A JUSTIFICATION.

ATTITUDES AND MOTIVATIONS

THESE SHOULD BE IMPROVED AS A BY-PRODUCT OF THE STUDENT GETTING IMPERSONAL, INDIVIDUAL, AND CONTINUOUS PRACTICE RATHER THAN WAITING AROUND FOR THE INSTRUCTOR'S ATTENTION, OR MAKING MISTAKES AND NOT KNOWING WHAT HE DID INCORRECTLY FOR SUBSTANTIAL PERIODS OF TIME. THE STUDENT MAY,

FIGURE III-2. ID FILE EXAMPLE

PAGE NUMBER : 2

SOURCE CARD LISTING FOR
**ID

EARLY IN LEARNING THE TASK, GET A PROPER SENSE OF PACE WHICH CAN BE FORCED BY THE PROGRAMMING OF THE INSTRUCTIONAL GUIDANCE.

APTITUDES

THESE MAY BE AFFECTED, BUT ONLY AS A BY-PRODUCT OF OTHER FACTORS. THE TRAINER CAN REDUCE THE DEPENDENCE OF INSTRUCTOR AND STUDENT ON THE STUDENT'S ABILITY TO LEARN SYMBOLIC MATERIALS WHICH MAY NOT BE HIGHLY CORRELATED WITH HIS ABILITY TO LEARN THE PROCEDURES BY ACTUAL PHYSICAL OPERATIONS.

SOCIAL FACTORS

NO INTENDED INFLUENCE.

SETBACKS AND ATTRITION

THE REDUCTION OF THESE IS A SECONDARY TARGET.

STUDENT EVALUATION

A CONTINUOUS, OBJECTIVE RECORD OF THE ERRORS MADE BY THE STUDENT IS MAINTAINED THIS SHOULD BE SUPERIOR TO INSTRUCTOR EVALUATIONS. THE DEVICE MAY BE USED TO KEEP THE STUDENT PRACTICING UNTIL THE DESIRED PERFORMANCE CRITERION IS REACHED.

EMPIRICAL DATA

STUDY PERFORMED ON TWO PIECES OF EQUIPMENT.

QUANTITATIVE BENEFITS

MEASURED RESULTS

CONTROL: NORMAL TRAINING OPERATIONS.

EXPER: USE OF INNOVATION ON SAME EQUIPMENTS, SAME PROCEDURES TO BE LEARNED.

RESULTS: TESTED ON LIVE EQUIPMENT AFTER EQUAL HOURS OF ELAPSED TIME.

1. IMMEDIATELY AFTER TRAINING: EXPER WERE 40% SUPERIOR.

2. RETEST ONE MONTH LATER: EXPER 60% SUPERIOR. (EQUIVALENT TO REDUCING OJT FROM 4 WEEKS TO 1 WEEK.)

3. TEST SIX MONTHS AFTER ON JOB:

EXPER: 30% RATED "OUTSTANDING."

CONTROL: 5% RATED AS "OUTSTANDING."

4. ATTRITION

EXPER: 1%

CONTROL: 7%

CRITERION VARIABLES FOR MEASURING TRAINING EFFECTIVENESS

VALIDITY AND COMPLETENESS IN LEVEL OF PROFICIENCY.

TARGET: HIGHER LEVEL OF OPERATIONAL PROFICIENCY IN PROCEDURES PERFORMANCE.

QUANTITATIVE COSTS

ESTIMATED OPERATION COSTS FOR INNOVATION, 8 YEARS: \$7.00 PER STUDENT HOUR.

PRESENT OPERATING COST FOR TRAINING: \$8.50 PER STUDENT HOUR.

EXPER: ONE INSTRUCTOR PER 20 STUDENTS.

CONTROL: ONE INSTRUCTOR PER 4 STUDENTS.

ESTIMATES OF MAGNITUDES OF BENEFITS/SAVINGS UNDER ACTUAL CONDITIONS

80% REDUCTION IN ATTRITION RATE.

75% SAVINGS IN OJT PER INCUMBENT.

REDUCTION IN STANDBY AND SPARE EQUIPMENT.

DECREASES IN MISSION FAILURES.

ESTIMATES OF THE PRACTICAL IMPORTANCE OF THE TRAINING PRODUCT

PRACTICAL PROCEDURAL PROFICIENCY: CRUCIAL IMPORTANCE TO OPERATIONS.

RESOURCE REQUIREMENTS FOR FURTHER STUDY

TECHNICAL DEVELOPMENT: \$12 MILLION OVER 3 YEARS.

EMPIRICAL STUDIES \$ 3 MILLION OVER 3 YEARS.

PAGE NUMBER : 1

SOURCE CARD LISTING FOR
**REC

**REC
30
31
40
64
-80
-81
83
84
85
86
87

FIGURE III-3. REC FILE EXAMPLE

TAEG REPORT NO. 40

Pos 1- 8 Record 1 = COURSES
 2 = VEHICLES
 3 = TASKS

Pos 9- 10 A fixed binary designation of the number of
 descriptors which will be available as search
 arguments.

Pos 11-240 115 zeros or signed fixed binary values which
 have a positional relationship to the descriptors
 for courses, vehicles, or job/tasks; e.g., Pos
 11-12 corresponds to descriptor 01, Pos 69-70
 to descriptor 30, etc.

The REC file shown in Figure III-3 contained the following search or query
 descriptors: 30 31 40 64 -80 -81 83 84 85 86 87. An example of the
 SARG file which relates to the contents of this example REC file is shown in
 Figure III-4.

RESU (Search Results). This file contains the entities from the Abbreviated
 Data Bases which had descriptors matching the search arguments in the SARG
 file. The search results can subsequently be refined by adding or deleting
 entities.

The format of the RESU file is as follows:

Pos	1	Entity Type; i.e., Course(1), Vehicle(2), Job/Task(3)
Pos	2	Record Type; i.e., Original(1), Added(2), Deleted(3)
Pos	3	Status of Abbreviated Data; i.e., Avail(1), Unavail(2)
Pos	4- 16	Identification of Entity; i.e.,
		Course(Type 1)
	Pos 4- 11	Course Identification Number(CIN)
	Pos 12- 15	Course Data Processing(CDP)
	Pos 16	Blank
		Vehicle(Type 2)
	Pos 4- 16	Vehicle ID
		Job/Task(Type 3)
	Pos 4- 8	Rating; e.g., AO, BM
	Pos 9- 10	Rank; e.g., 3, CS
	Pos 11- 15	Job/Task; e.g., 34410
	Pos 16	Blank

An example of the results in RESU from searching the Abbreviated Data Base
 for Courses using the contents of REC is shown in Figure III-5.

The RESU file can be printed either from the P1 print program or from P5.

REE (Range-of-Effect, Extract). This file has the same format as the RESU
 file. It will contain all search results except the entities which were
 subsequently deleted when the search results were refined interactively.
 Thus, it will contain only Original(1) and Added(2) record types. Its pur-
 pose is to reflect entities for which additional data are being requested to
 be used in the Assessment process. It, therefore, reflects the content of
 the printed Extract Reports, except that the Extract Reports will contain
 additional descriptive data obtained from the Abbreviated Data Bases.

TAEG REPORT NO. 40

REC POS	RECORD CONTENT	DESC NO.
1- 8	COURSES	
9- 10	11	
11- 68	All plus zeros(29)	(01-29)
69- 72	+1+1	(30-31)
73- 88	All plus zeros(8)	(32-39)
89- 90	+1	(40)
91-136	All plus zeros(23)	(41-63)
137-138	+1	(64)
139-168	All plus zeros(15)	(65-79)
169-172	-1-1	(80-81)
173-174	All plus zeros(2)	(82)
175-184	+1+1+1+1+1	(83-87)
185-240	All plus zeros(56)	(88-115)

FIGURE III-4 SARG FILE EXAMPLE

TAEG REPORT NO. 40

ERS
TTT CIN CDP
112A 0001110327
111A 2E00130303
111A 2G00140143
112A 4A0025
111A10101087654

FIGURE III-5 RESU FILE EXAMPLE

EXC (Extract Courses). This file contains the additional data on the courses matched in the Range-of-Effect search. These data are required to run the Training Cost Model in order to calculate the cost effects of applying the benefit pattern, associated with implementing the innovation, to the range of courses which will benefit from the innovation. The data are presently planned to be collected from appropriate Navy sources. Much of the data are available in NITRAS, however, other data must be collected manually. A list of the data elements required for each Range-of-Effect selected course is shown in Figure III-6.

EXV (Extract Vehicles). This file contains the additional data on vehicles matched in the Range-of-Effect search. These data are required to input the Vehicles Cost Model in order to calculate the effect of implementing an innovation. The data are presently planned to be collected from appropriate Navy sources; e.g., the Naval Training Equipment Center, Orlando, Florida. A list of the data elements required for each Range-of-Effect selected vehicle is shown in Figure III-7.

EXJ (Extract Job/Tasks). This file contains the additional data on job/tasks matched in the Range-of-Effect search. These data are required to input the job/task cost model for assessing the cost pattern in the job domain as a result of accepting and successfully implementing the proposed innovation. These data are presently planned to be collected from appropriate Navy sources; e.g., Bureau of Naval Personnel, Occupational Standards Development and Navy Occupational Task Analysis Program. A list of the data elements required for each Range-of-Effect selected job/task is shown in Figure III-8.

EXD (Extract, Defaults). This file contains technical and cost data which should be used by the three cost model programs when data are not available in the appropriate extract file; i.e., EXC, EXV, or EXJ. For example, the input variables required as input to the Training Cost Model were defined under the EXC file. The model, as presently designed and listed in Appendix C, contains built-in default values to substitute in the program when the data requested in the READ operation are missing. Since changes in default values would require program modification and recompilation, when the final training cost model is developed the default values should be substituted with variables which reference the EXD file. Thus, as default values change, only this file will require updating. Refer to Appendix C, Page C-5 for the variables identified in the Training Cost Model for which default values will be required.

BPT (Benefit Pattern). Each innovation being assessed by ETAM will have a pattern of benefits which can be described and stored in the care-image text file. Benefit variables, both quantitative and qualitative, and the manner in which the innovation affects them should be commented upon in this file. This descriptive information will be used by the assessor in establishing the model inputs interactively. An example of the BPT file content is shown in Figure III-9.

CMR (Cost Model Results). The outputs of the three cost models; i.e., Training, Vehicles, and Job/Tasks, will be stored in this file for use in the Decision Analysis and Financial Analysis routines.

TAEG REPORT NO. 40

REC POS	VARIABLE DESCRIPTION	SYMBOL	LENGTH	FORMAT
1-4	Course Number (CDP)	CDP	4	A4
5-6	Planning Period (Years)	N	2	I2
7-9	Attrition Rate (PCT)	ARATE	3	F3.2
10-13	Training Length (Weeks)	TLENGH	4	F4.1
14-15	Recycle Rate	RCRATE	2	F2.2
16-18	Ave Recycle Time (Weeks)	ARCYTM	3	F3.1
19-21	Weeks School Operates	WSCHOP	3	F3.1
22-23	Time Student Position Down (PCT)	TSPOSD	2	F2.2
24-27	Instr/Student Positive Ratio	INTSPO	4	F4.2
28-30	Admin/Student Position Ratio	AMTSP0	3	F3.3
31-33	Equip/Student Position Ratio	EQU SPO	3	F3.2
34	Purchase Policy	PURCHF	1	I1
35	Depreciation Policy	DEPF	1	I1
36-37	Life of Equipment	LOFEQ	2	I2
38-42	SQ Feet/Student Position	SQFTST	5	F5.2
43-47	SQ Feet/Instructor Position	SQFTIN	5	F5.2
48-52	SQ Feet/Admin Position	SQFTAM	5	F5.1
53-56	Course Dev Hours/Course Hour	IMDDEV	4	F4.1
57-59	Percent Course Requiring Dev (PCT)	PUI MD	3	F3.2
60-61	Percent Instr Mat Maintained (PCT)	UPDATE	2	F2.2
62-65	Supplies/Student Position	SUP SPO	4	F4.1
66-69	Supplies/Student	SUP STD	4	F4.1
70-73	Misc/Student Position	MSC SPO	4	F4.1
74-77	Misc/Student	MSC STD	4	F4.1
78-79	Percent Extra Student Positions (PCT)	PESP	2	F2.2
80-83	Time in Medium (Hrs/Wk)	TLEGTH	4	F4.1
84-85	Life of Facility	LOFFA	2	I2
86-88	Week School Available	WSHOP1	3	F3.1
89-95	Student Salary (Annual)	STUDSL	7	F7.2
96-101	Student Travel Cost To/From	STCST1	6	F6.2
102-107	Student Travel Cost in Course	STCST2	6	F6.2
108-114	Instructor Salary (Annual)	INSTSL	7	F7.2
115-121	Admin Salary (Annual)	ADMSL	7	F7.2
122-129	Equipment Unit Cost	EQU NTC	8	F8.2
130-132	Pct Max Equip Purchased	PCTPCH	3	F3.2
133-137	Facility Cost/SQ FT	CPSQFT	5	F5.2
138-142	Cost/Hour of Instr Mat Dev	CIMD	5	F5.2
143-144	Pct Instr Material Remaining Value	EVIM	2	F2.2
145-149	Supplies Cost	CSUPP	5	F5.2
150-154	Miscellaneous Cost	CMIS	5	F5.2
155-157	Discount Rate	DRATE	3	F3.3
158-160	Inflation Rate	INRATE	3	F3.3
161-168	Facility Init/Refurb Cost	FACST	8	F8.2
169-288	Graduates	GRAD(I)	120	2016
289-388	O&MN Annual Maint Costs	COPMT(I)	100	20F5.0

Record Length = 388 Positions

FIGURE III-6. EXC DATA ELEMENTS

TAEG REPORT NO. 40

<u>REC POS</u>	<u>VARIABLE DESCRIPTION</u>	<u>SYMBOL</u>	<u>LENGTH</u>	<u>FORMAT</u>
1-13	Vehicle Federal Stock Number	VFSN	13	A13
14-15	Planning Period (Years)	N	2	I2
16	Equipment Depreciation Policy	DEPF	1	I1
17-18	Life of Equipment	LOFEQ	2	I2
19-26	Equipment Unit Cost	EQUINC	8	F8.2
27-34	Equipment Installation Cost	EQINSC	8	F8.2
35-37	Discount Rate	DRATE	3	F3.3
38-40	Inflation Rate	INRATE	3	F3.3
41-160	Equipment Planned Purchases	PEQUIP(1)	120	2016
161-260	O&MN Annual Maint Costs	COPMT(1)	100	20F5.0

Record Length - 260 Positions

FIGURE III-7. EXV DATA ELEMENTS

TAEG REPORT NO. 40

<u>REC POS</u>	<u>VARIABLE DESCRIPTION</u>	<u>SYMBOL</u>	<u>LENGTH</u>	<u>FORMAT</u>
1-13	Job/Task Identifier	JTID	13	A13
14-15	Planning Period	N	2	I2
16-20	Task Performance Time (HRS)	TTASK	5	F5.1
21-25	Task Frequency/Person/Year	FTASK	5	F5.0
26-27	Pct Officers Performing	OPTSK	2	F2.2
28-29	Pct Enlisted Performing	EPTSK	2	F2.2
30-31	Pct Civilian Performing	CPTSK	2	F2.2
32-34	Error Rate/Freq. Performed	ERTSK	3	F3.3
35-42	Non Manpower Cost/Error	OERRC	8	F8.2
43-49	Officer Billet Cost	OFFSL	7	F7.2
50-56	Enlisted Billet Cost	ENLSL	7	F7.2
57-63	Civilian Cost	CIVSL	7	F7.2
64-71	Support Cost/Year/Person Performing	SUPPC	8	F8.2
72-74	Discount Rate	DRATE	3	F3.3
75-77	Inflation Rate	INRATE	3	F3.3
78-197	Annual Personnel Available	APERS(I)	120	2016

Record Length = 197 Positions

FIGURE III-8. EXJ DATA ELEMENTS

PAGE NUMBER : 1

SOURCE CARD LISTING FOR
**BPT

**BPT
REFERENCE "EMPIRICAL DATA" SECTION OF ID FILE FOR EXPERIMENTAL RESULTS AND
INITIAL PATTERN OF BENEFITS.

BENEFIT PATTERN
TRAINING BENEFITS

1. ATTRITION RATE - ESTIMATED REDUCTION APPROXIMATELY 80% (FROM 7% TO 1%).
THE DOLLARS SAVED BY THE ATTRITION REDUCTION HAVE BEEN
ASSIGNED AN IMPORTANCE RATING OF 10 DUE TO PRESENT
FUNDING PRESSURE.

CONFIDENCE RANGE -- BEST CASE, 85% REDUCTION--
-- WORST CASE 50% REDUCTION--

LIABILITY TO REDUCTION IN ATTRITION RATE: INAPPROPRIATE
EMPHASIS ON EVALUATING STUDENT ON "THEORY OF OPERATION"
CONTENT IN COURSE. WOULD NOT AFFECT ATTRITION RATE ON
TARGETED OBJECTIVE, BUT ON THE COURSE ITSELF.

NOTE: IF THE REDUCTION IN ATTRITION HAD VALUE OTHER
THAN IN DOLLARS SAVED, THEN IT WOULD HAVE BEEN
ASSIGNED AN IMPORTANCE LEVEL AS OTHER NONQUANTI-
FIABLE VARIABLES ARE. THIS MIGHT BE THE CASE
WHERE THE PARTICULAR MANPOWER POOL IS IN SHORT
SUPPLY.

2. APTITUDE REQTS - THERE IS A POTENTIAL FOR REDUCTION BUT IT IS NOT
QUANTIFIABLE AT THIS TIME.
3. TRAINING PROGRAM DEVELOPMENT FLEXIBILITY - INCREASED - IMPORTANCE=2.

JOB BENEFITS

1. ON-JOB-TRNG - ESTIMATE NORMAL OJT BEFORE ACCEPTABLE PERF - 4 WEEKS
ESTIMATE OF OJT REQUIRED WITH INNOVATION - 1 WEEK
THE DOLLARS SAVED BY THE OJT REDUCTION, AS WITH ATTRI-
TION DOLLARS, HAVE BEEN ASSIGNED AN IMPORTANCE OF 10.
CONFIDENCE RANGE -- BEST CASE, .5 WEEK WITH INNOVATION--
-- WORST CASE, 1.5 WEEKS--
2. STANDBY JNITS - REDUCED - IMPORTANCE=1.
CONFIDENCE RANGE -- BEST CASE, 50% REDUCTION--
-- WORST CASE, 10% REDUCTION--

FIGURE III-9. BPT FILE EXAMPLE

TAEG REPORT NO. 40

The file is formatted as follows:

Pos	1	Cost Model Type Output; i.e., Training (Courses)(1), Vehicle(2), Job/Task(3), Risk Projects(4), Course Total(5), Vehicle Total(6), Job/Task Total(7), Entity Total (5+6+7)(8), Project Total (4+8)(9).
Pos	2- 14	Entity Identifier; e.g. CDP, FSN, "Course Total", etc.
Pos	15- 19	Count of Entities Summarized
Pos	20- 21	Planning Period in Years (Indicate Longest in Summaries).
Pos	22-201	Investment Vector (20-9 Pos \$ Fields for 20 Years)
Pos	202-381	Savings Vector (20-9 Pos \$ Fields for 20 Years)

RKP (Risk Profile). The introduction of an innovation will have attendant risks which affect the success probabilities associated with its implementation and acceptance. The nature and degree of risk will assist in structuring risk reduction projects. A summary of the degree of risk by risk category, the number of risk projects which have been identified for each risk category, and the estimated cost of the projects in each risk category appear at the beginning of the RKP file. There are seven identified risk categories numbered 1 through 7 in the summary. A number 0 card contains header information and a number 8 card gives an overall profile of the risk. As many number 9 cards as desired can be used to provide descriptive information on the nature of the risks in each category. An example of the contents of the BPT file is shown in Figure III-10. This file can be printed with the P1 print program.

RRPJ (Risk Reduction Projects). This card-image file contains descriptive and resource data associated with each risk reduction project proposed. Type 0 records in this file contain the project identification, project name, date, and dollar value of the project. Type 1 records will contain descriptive data on the project including an abstract, objectives, project plan milestones, etc. Type 2 through 7 records in the RRPJ file will contain specific resource requirements by resource category. Type 2 records are for personnel resources, Type 3 records are for equipment resources, Type 4 records are for space resources, Type 5 records are for staff travel resources, Type 6 records are for student resources, and Type 7 records are for other resources.

The file is formatted as follows:

All Record Types-

Pos	1	Record Type (0-7)
Pos	2	-

Type 0 Record-

Pos	3- 10	Project Identification
Pos	11- 12	Blank
Pos	13- 58	Project Name
Pos	59- 60	Blank
Pos	61- 68	Date (MM/DD/YY)
Pos	69- 71	Blank
Pos	72- 80	Cost of Project

PAGE NUMBER : 1

SOURCE CARD LISTING FOR
**RKP

**RKP	0-RISK CATEGORY / DEGREE OF RISK -	HIGH	MOD	NONE	SUPPORT	PROJ	COST
1	IMPORTANCE TO PROJECTED NAVY MISSION	0	1	0	0		
2	ORGANIZATIONAL COMPATIBILITY	0	0	1	0	00	000000000
3	GOALS/POLICY COMPATIBILITY	0	0	0	1	00	000000000
4	STATE-OF-THE-ART	0	1	0	0	04	110000000
5	R&D FUNDING REQUIREMENTS	0	1	0	0	00	000000000
6	TECHNICAL SUPPORT REQUIREMENTS	0	1	0	0	00	000000000
7	ATTITUDINAL ACCEPTANCE	0	1	0	0	01	55000
8	OVERALL PROFILE-TOTAL PROJECTS/DOLLARS	0	1	0	0	05	11055000

9- FOLLOWING IS DESCRIPTIVE INFORMATION ON EACH RISK AREA SUMMARIZED ABOVE.

9- IMPORTANCE TO PROJECTED NAVY MISSION
9- OF MODERATE IMPORTANCE

9- ORGANIZATIONAL COMPATIBILITY
9- IRRELEVANT TO NAVY COMMAND AND CAREER STRUCTURES

9- GOALS/POLICY COMPATIBILITY
9- SUPPORT OF POLICY TO INCREASE PRACTICAL SKILL LEVELS

9- STATE-OF-THE-ART
9- MODERATE PROBABILITY OF SUCCESS WITH SOME ADDITIONAL R&D EFFORT REQUIRED
9- PROBLEMS:

9- HARDWARE LINKAGES OF EQUIPMENT TO COMPUTER SENSORS
9- TRAINING LABORATORY LOCATIONS WILL PRESENT SOME PROBLEMS IN TYING
9- STUDENT STATIONS TO A REMOTE COMPUTER FACILITY. PRESENT TECHNOLOGY
9- PERMITS LINE LENGTHS OF UP TO 2000 FEET TO BE DRIVEN AT REASONABLE COST.
9- SOME FACILITIES ARE A HALF-MILE FROM THE COMPUTER SITE. R&D EFFORTS
9- SHOULD BE DEVOTED TO FINDING A TECHNOLOGY CAPABLE OF DRIVING LINES UP TO
9- ONE MILE AT REASONABLE COST.

9- SIMULATION OF TEMPORAL RESPONSE TO OPERATION ACTIONS
9- PRESENT COMPUTATIONAL SPEEDS WOULD CAUSE DELAYS OF UP TO 4 SECONDS IN
9- RESPONDING TO OPERATION ACTIONS. THIS MAY AFFECT STUDENT ACCEPTANCE OF
9- THE DEVICE, BUT MORE SO, MAY IMPAIR THE LEARNING OF CERTAIN OPERATIONAL
9- PROCEDURES WHERE A SEQUENCE OF ACTIONS MUST BE LEARNED AND WHERE MORE
9- RAPID FEEDBACK MAY BE ESSENTIAL. AN ASSESSMENT (STUDY) OF THE APPROXI-
9- MATE AMOUNT OF TRAINING TAKING PLACE ON ACTUAL EQUIPMENT, WHICH FASTER
9- RESPONSE THAN IS NOW POSSIBLE, SHOULD BE MADE. ADDITIONAL STUDY SHOULD
9- ALSO BE DIRECTED AT DETERMINING STUDENT ATTITUDE EFFECTS, ESPECIALLY AS
9- THEY MIGHT RELATE TO DECREASED LEARNING EFFECTIVENESS.

9- RELIABILITY OF HARDWARE/SOFTWARE PERFORMANCE
9- AVAILABILITY OF STUDENT TRAINERS WILL BE THE KEY TO ACHIEVING DESIRED
9- OBJECTIVES. PRESENT COMPUTER RELIABILITY WOULD APPEAR TO INDICATE AN
9- AVAILABILITY OF BETWEEN 90% AND 95%. IT MUST BE DETERMINED IF SUFFI-
9- CIENT TRAINING CONTINGENCY PLANS CAN BE ADOPTED TO COPE WITH THIS LEVEL
9- OF RELIABILITY.

9- LEAD TIME NEEDED TO PROGRAM THE TRAINING FUNCTIONS ON DEVICE
9- THE PROPOSED TRAINER IS GENERAL PURPOSE AND ITS UNIQUENESS TO THE
9- TRAINING SITUATION WILL PRIMARILY RESULT FROM PROGRAMMING THE INTER-
9- RELATIONSHIPS BETWEEN OPERATOR CONTROLS AND FEEDBACK SIGNALS (LIGHTS,
9- METERS, ETC.). PROGRAMMING TIME WAS ASSESSED FOR THE EXPERIMENTAL
9- APPLICATION, BUT NO SPECIFIC TECHNIQUES WERE ANALYZED FOR SPEEDING THE
9- PREPARATION OF PROGRAMS. A MAJOR STUDY SHOULD BE UNDERTAKEN TO INVESTI-
9- GATE POSSIBLE TECHNIQUES FOR IMPROVING PROGRAMMING EFFICIENCY.

9- FUNDING
9- LARGE OR VERY LARGE INVESTMENT TO BRING THE INNOVATION TO AN OPERATIONAL
9- LEVEL OF IMPLEMENTATION (NEAR MAXIMUM THAT CAN BE COMMITTED TO ONE PROJECT).

9- TECHNICAL SUPPORT REQUIREMENTS
9- SOME DIFFICULTY IN GETTING R&D TALENT AND IMPLEMENTATION TALENT.

FIGURE III-10. RKP FILE EXAMPLE

PAGE NUMBER : 2

SOURCE CARD LISTING FOR
**RKP

9- ATTITUDINAL ACCEPTANCE
9- MODERATE BUT TEMPORARY RESISTANCE BY INSTRUCTIONAL COMMUNITY, ESPECIALLY
9- IF THERE WILL BE DIFFICULTIES IN OPERATION, EQUIPMENT RELIABILITY, OR SYSTEM
9- AVAILABILITY AND RESPONSIVENESS.
9- PROBLEMS:
9-
9- STUDENT ACCEPTANCE
9- ACCEPTANCE OF THE INSTRUCTIONAL COMMUNITY WILL, TO A GREAT EXTENT, BE
9- A FUNCTION OF SUCCESSFULLY OVERCOMING THE RISK ITEMS STATED ABOVE.
9- EXCESSIVE SYSTEM DOWNTIME OR SLOW RESPONSE TIME COULD SERIOUSLY IMPACT
9- STUDENT ACCEPTANCE. APPROPRIATE ORIENTING PRESENTATIONS SHOULD BE PRE-
9- PARED TO HELP OVERCOME RESISTANCE OF ADMINISTRATORS AND STUDENTS.
9-

FIGURE III-10. RKP FILE EXAMPLE (Cont'd)

TAEG REPORT NO. 40

Type 1 Record-

Pos 3- 80 Descriptive Data

Type 2-7 Record-

Pos 3- 47 Resource Descriptive Data
 Pos 48- 49 Blank
 Pos 50- 58 Resource Quantity Data
 Pos 59- 60 Blank
 Pos 61- 69 Unit Cost
 Pos 70- 71 Blank
 Pos 72- 80 Job Cost

An example of the contents of the RRPJ file is shown in Figure III-11.

RRPK (Risk Reduction Packages). The projects defined in the RRPJ file are grouped into various packages, each of which will have some level of effect upon the implementation and user acceptance success probabilities which become a part of the decision tree evaluation. This file also contains the probability factors associated with (1) risk package implementation success, (2) effect upon innovation implementation success, and (3) effect upon success of the innovation considering its acceptance by the using system. The file is formatted as follows:

Pos	1	Risk Reduction Package Number (0-9)
Pos	2	-
Pos	3	0 for 1st Card of Any Risk Reduction Package
Pos	4	Blank
Pos	5- 10	Risk Package Designator
Pos	11- 12	Blank
Pos	13- 20	Project Identifier (A Position 1 = 0 Record has special header info - See Figure III-12)
Pos	21- 80	Repeat of Pos 11-20
Pos	3	1 for 2nd Card of Any Risk Reduction Package
Pos	4- 12	Blank
Pos	13- 20	PP_p PP_m PP_o three probabilities related to the expected success of the Risk Reduction Package. PP_p is the pessimistic probability, PP_m the expected, and PP_o the optimistic.
Pos	21- 22	Blank
Pos	23- 30	Three probabilities as in Pos 13-20 related to the expected success of being able to implement the innovation given that the identified Risk Reduction Package succeeds.
Pos	31- 32	Blank
Pos	33- 40	Three probabilities as in Pos 13-20 related to the expected success of gaining user acceptance of the innovation, once the innovation is implemented.
Pos	41- 42	Blank
Pos	43- 51	Planned cost of All Risk Reduction Projects in the particular package.

PAGE NUMBER : 1

SOURCE CARD LISTING FOR
**RRPJ

**RRPJ
0-001-ATTD USER ORIENTATION FOR 3-D TRAINER 5/02/77 55000
1-
1-ABSTRACT
1- IMPLEMENTATION OF THE 3-D PROCEDURAL TRAINER THROUGHOUT THE TRAINING
1-COMMAND WILL BE ACCOMPANIED BY A GREAT DEAL OF RESISTANCE, ESPECIALLY AT THE
1-COMMAND LEVELS. ONE SOLUTION TO THIS PROBLEM IS TO ENSURE THAT AN ADEQUATE
1-UNDERSTANDING OF THE DEVICE EXISTS WITH OFFICERS AND STAFF WHO WILL BE RESPON-
1-SIBLE TO MANAGE THE IMPLEMENTATION AND OPERATION OF THESE DEVICES WITHIN THEIR
1-COMMAND. THIS WILL BE ACCOMPLISHED BY DEVELOPING A 15-MINUTE COLOR MOVIE ON
1-THE DEVICE, ITS FEATURES, AND ITS APPLICATION, FOR PRESENTATION TO COMMAND
1-LEVEL OFFICERS AND STAFF PERSONNEL PRIOR TO THE PLANNING STAGE FOR ONE OF
1-THESE DEVICES. THREE PERSONS WILL REQUIRE A TOTAL OF 12-MAN MONTHS TO DEVELOP
1-THE MOVIE AT AN ESTIMATED COST OF \$55,000. DEVELOPMENT WILL BE SCHEDULED TO
1-BEGIN MAY 1977 AND COMPLETE APRIL 1978.
1-OBJECTIVES
1- DEVELOP 15-MINUTE COLOR MOVIE ON 3-D PROCEDURAL TRAINER.
1- IMPROVE ACCEPTANCE OF USERS AT COMMAND LEVEL.
1-PROJECT PLAN MILESTONES
1- PREPARE FINAL IMPLEMENTATION PLAN. JAN 1977
1- OBTAIN FUNDING APPROVAL MAR 1977
1- RECRUIT PERSONNEL. APR 1977
1- BEGIN DESIGN-CONSULTATION TRIPS. MAY 1977
1- COMPLETE DESIGN. OCT 1977
1- BEGIN PHOTOGRAPHY. NOV 1977
1- COMPLETE PHOTOGRAPHY. FEB 1978
1- OBTAIN PRINTS. APR 1978
1- DISTRIBUTE PRINTS FOR USE. MAY 1978
2-PERSONNEL -JOB- MAN MONTHS \$/MM JOB COST
2- MOVIE DESIGN LAYOUT (GS-12) 6 1855 11130
2- PHOTOGRAPHY (PH6) 4 1630 6520
2- ADMINISTRATIVE 2 970 1940
3-EQUIPMENT -DESCRIPTION- QUANTITY UNIT COST JOB COST
3- PROTOTYPE DEVICE FOR USE IN DESIGN 1 12400 12400
3- OF SEQUENCES AND FILMING
4-SPACE -REASON- SQ FT \$/SQ FT JOB COST
4-
5-TRAVEL-STAFF -FROM-TO-REASON NO. TRIPS \$/TRIP JOB COST
5- MULTI-LOCATION TRAVEL FOR CONSULTATION/FILM 20 300 6000
5-
6-STUDENT -NO. OF STUDENTS-REASON NO. DAYS \$/DAY JOB COST
6-
7-OTHER -DESCRIPTION- MM/QTY UNIT COST JOB COST
7- PROCESSING AND REPRODUCTION 1 6010 6010
7- OF 100 COPIES OF THE FILM 100 110 11000
7-
0-001-SART NEXT PROJECT
1-

FIGURE III-11. RRPJ FILE EXAMPLE

An example of the contents of the RRPK file is shown in Figure III-12.

VQAL (Variables Qualitative). This card-image file contains descriptive data on the qualitative variables impacted by the adoption of the proposed innovation. These data will be reviewed by the assessor along with the cost model results in the scaling process. In sequence at the beginning of this file is a list which may have potential for being affected by implementing the innovation. The format for this part of the file is:

Pos	1- 3	Variable Reference Number 001-998 000 = COURSES 001-399 are reserved for training related variables. 400 = VEHICLES 401-699 are reserved for vehicle related variables. 700 = JOB/TASKS 701-998 are reserved for job/task related variables. 999 indicates the end of the variable list.
Pos	4	Blank
Pos	5- 33	Variable Name - Names should be limited to 29 characters to fit in name field of VARF file.

The remainder of the file contains the specific qualitative variables associated with the project which are planned for incorporation into the Decision Tree utility outcomes.

The format for this part of the file is:

Pos	1- 3	Variable Reference Number - 001-998
Pos	4	Blank
Pos	5- 80	Descriptive Data - The first of possible multiple records will contain the Variable Name in Pos 5-33. Each record related to the same variable will contain the same Variable Reference Number in Pos 1-3.

An example of the contents of the VQAL file is shown in Figure III-13.

VARF (Variable Reference). Each of the variables, including costs will be valued during the interactive scaling process. An importance weighting factor and an equivalent dollar (utility) value will be developed for each of the four possible decision tree outcomes. The summation of the outcome values stored in this file for each variable will be used in the decision tree evaluation.

The format of this card-image file is as follows:

Pos	1- 3	Variable Reference Number - a 000 in these positions refers to the direct cost results from 1) running the cost models and identifying the savings if the full benefit pattern is achieved, and 2) interactively (or in batch) assigning cost/savings which occur at the Decision Tree outcomes where the full benefit pattern (and most likely several liabilities) does not occur.
-----	------	--

PAGE NUMBER : 1

SOURCE CARD LISTING FOR
**RRPK

```

**RRPK
0-0 NORISK  PROJ-SUC  IMPL-SUC  USER-SUC  PROJ-COST
0-1          00 00 00  65 75 85  40 50 60
1-0 RKPKG1  001-SART  002-SART  003-SART  004-SART  001-ATTD
1-1          90 95 99  80 85 90  50 60 70  11055000
2-0 RKPKG2  001-SART  003-SART  004-SART
2-1          90 95 99  80 85 90  50 60 70  9000000
3-0 RKPKG3  002-SART  003-SART  001-ATTD
3-1          90 95 99  70 75 80  80 85 95  3055000
4-0 RKPKG4  PROJECT GROUP 4 IF APPLICABLE
4-1          PROJ-SUC, IMPL-SUC, USER-SUC, PROJ-COST IF APPLICABLE FOR PROJ GRP 4
5-0 RKPKG5  PROJECT GROUP 5 IF APPLICABLE
5-1          PROJ-SUC, IMPL-SUC, USER-SUC, PROJ-COST IF APPLICABLE FOR PROJ GRP 5
6-0 RKPKG6  PROJECT GROUP 6 IF APPLICABLE
6-1          PROJ-SUC, IMPL-SUC, USER-SUC, PROJ-COST IF APPLICABLE FOR PROJ GRP 6
7-0 RKPKG7  PROJECT GROUP 7 IF APPLICABLE
7-1          PROJ-SUC, IMPL-SUC, USER-SUC, PROJ-COST IF APPLICABLE FOR PROJ GRP 7
8-0 RKPKG8  PROJECT GROUP 8 IF APPLICABLE
8-1          PROJ-SUC, IMPL-SUC, USER-SUC, PROJ-COST IF APPLICABLE FOR PROJ GRP 8
9-0 RKPKG9  PROJECT GROUP 9 IF APPLICABLE
9-1          PROJ-SUC, IMPL-SUC, USER-SUC, PROJ-COST IF APPLICABLE FOR PROJ GRP 9
    
```

FIGURE III-12. RRPK FILE EXAMPLE

PAGE NUMBER : 1

SOURCE CARD LISTING FOR
**VQAL

```
**VQAL
000 COURSES
001 AVAIL OF TRND PERSONNEL
002 FLEX IN PERF TRNG OPNS
003 SKILL LEVEL OF INSTR PERS
004 TRAINING QUALITY
005 STUDENT MORALE
006 MOTIVATION
007 STUDENT LRNG RETENTION
008 INSTR APTITUDE RQMTS
009 TRAINING SAFETY
010 COURSE SCHEDULING
011 ACCEPTANCE OF TRAINING
400 VEHICLES
401 PORTABILITY OF EQUIP
402 PROGRAMMABILITY
403 FLEXIBILITY IN USAGE
404 MAINTAINABILITY
405 UPDATE TO INSTR FUNCTION
406 TRNG CONTENT MODULARIZATN
700 JOB/TASKS
701 FLEX IN WORK ASSIGNMENT
702 RETENTION OF SKILL
703 AVAIL IN STANDBY EQUIP
704 JOB STRESS
999 END
002 FLEXIBILITY IN PERFORMING OTHER TRAINING RELATED OPERATIONS
002 THE 3-D PROCEDURAL TRAINER WILL PERMIT INSTRUCTION PROGRAMS TO BE
002 DEVELOPED MODULARLY, AND MODULES WILL BE USABLE ACROSS TRAINING COURSES.
002 ALSO, HIGHER LEVEL PROBLEM PREPARATION LANGUAGES WILL FURTHER INCREASE
002 THE FLEXIBILITY IN TRAINING PROGRAM DEVELOPMENT.
002
703 INCREASED SKILLS DEVELOPED THROUGH IMPLEMENTATION OF THE PROCEDURAL
703 TRAINER SHOULD IMPROVE EQUIPMENT TO BE REDUCED BY APPROXIMATELY 30%.
703
```

FIGURE III-13. VQAL FILE EXAMPLE

TAEG REPORT NO. 40

A number from 001 through 998 references a qualitative variable stored in the VQAL project file. The number 999 is reserved for a total of the VARF cost and equivalent cost data. This record will be an input to the Decision Analysis routine's final decision tree calculation.

Pos	4	Blank
Pos	5- 6	Importance Weighting - this is a two digit number from 1 through 10 which will be used to weight the equivalent dollars (utility) associated with the variable. It is inputted via card or developed interactively.
Pos	7	Blank
Pos	8- 16	Decision Tree Outcome A Value - this is the value that this particular variable takes on after it has been evaluated in relation to actual costs, and then weighted by its importance.
Pos	17	Blank
Pos	18- 26	Decision Tree Outcome B Value - same as Pos 8-16 except it represents the weighted equivalent dollars for Outcome B of the decision tree.
Pos	27	Blank
Pos	28- 36	Decision Tree Outcome C Value - same as Pos 8-16 except it represents the weighted equivalent dollars for Outcome C of the decision tree.
Pos	37	Blank
Pos	38- 46	Decision Tree Outcome D - always zero, since this is the Reject outcome on the decision tree.
Pos	47- 51	Blank
Pos	52- 80	Variable Name - the short name for the variable (001 = COST) from the VQAL project file. A 999 in Pos 1-3 will have the term TOTAL in these positions.

An example of the contents of the VARF file is shown in Figure III-14.

SCEN (Scenarios). This is a file in which descriptions of each of the scenarios developed for the decision tree outcomes are stored. Up to four scenarios can be created, although generally the Reject decision path assumes a no change situation. The contents of this file will be used by the assessor in creating the values for each of the decision tree outcomes. The data are stored in 80-column card image format with major subdivisions made for each outcome (A, B, C and D). An example of the SCEN file is shown in Figure III-15.

PAGE NUMBER : 1

SOURCE CARD LISTING FOR
**VARF

**VARF						
000	10	46669728	1753862	-1000000	00	COST
002	02	8500000	-400000	-1000000	00	FLEX IN PERF TRNG OPNS
703	01	3800000	-1000000	-500000	00	AVAIL IN STANDBY EQUIP
999		58969728	353862	-2500000	00	TOTAL

FIGURE III-14. VARF FILE EXAMPLE

PAGE NUMBER : 1

SOURCE CARD LISTING FOR
**SCEN

**SCEN

THE FOLLOWING SCENARIOS REPRESENT THE QUANTITATIVE AND QUALITATIVE EXPECTED OUTCOMES AT EACH LEG OF THE DECISION TREE.

A - ATTRITION WILL BE REDUCED FROM .07 TO .01.

INSTR./STUD. POSITION RATIO WILL GO FROM .25 TO .05.

EQUIPMENT LIFE WILL GO FROM 5 YEARS TO 10 YEARS.

EQUIPMENT UNIT COST WILL GO FROM \$4375. TO \$5625.

OJT TIME WOULD BE REDUCED FROM 4 WEEKS TO 1 WEEK.

ALL OTHER COST DATA FROM THE FORMERLY PLANNED PROGRAM TO THE PROPOSED PROGRAM WILL REMAIN THE SAME.

STANDBY EQUIPMENT - THIS QUALITATIVE VARIABLE WHICH MEASURES THE GREATER AVAILABILITY OF STANDBY EQUIPMENT IN THE FLEET WILL BE IMPROVED OVER THE PRESENT STATE BY ABOUT 5 TO 1, ALTHOUGH IT IS ONLY ABOUT 1/10-TH AS IMPORTANT AS THE ATTRITION AND OJT TIME SAVINGS WHICH ARE EXPECTED TO ACCRUE.

FLEXIBILITY IN TRAINING PROGRAM DEVELOPMENT - THIS QUALITATIVE VARIABLE WHICH MEASURES THE GREATER FLEXIBILITY THAT PROGRAM DEVELOPERS WILL HAVE IN PREPARING COURSE CURRICULUM WILL BE IMPROVED OVER THE PRESENT STATE BY ABOUT 10 TO 1, ALTHOUGH ITS IMPORTANCE IS ONLY ABOUT 1/5-TH THAT OF THE ATTRITION AND OJT TIME SAVINGS WHICH ARE EXPECTED TO ACCRUE.

B - ATTRITION COULD FAIL TO REACH .01 AND WILL STAY AROUND .04.

TWO YEARS WILL BE REQUIRED TO DETERMINE ACCEPTANCE.

RECOVERY WILL BE ACCOMPLISHED BY REINSTITUTING THE BASELINE OR EXISTING PLAN ON WHICH THE IMPROVEMENTS IN OUTCOME A WERE BASED.

TRAINERS WILL HAVE NO SALVAGE VALUE AT END OF TWO-YEAR PERIOD.

NO OJT TIME WILL BE SAVED.

STANDBY EQUIPMENT - IF THE PROGRAM IS INSTITUTED AND FAILS TO GAIN USER ACCEPTANCE, THERE WILL BE A DECREASED AVAILABILITY OF EQUIPMENT FOR A CONSIDERABLE PERIOD OF TIME. THIS WILL PRODUCE A STATE WHICH IS ABOUT 20% AS NEGATIVE AS OUTCOME A IS POSITIVE.

FLEXIBILITY IN TRAINING PROGRAM DEVELOPMENT - THIS WILL BE AFFECTED IN A NEGATIVE MANNER ABOUT 3% TO 5% OF THE POSITIVE VALUE THAT WILL BE ACHIEVED BY OUTCOME A.

C - APPROXIMATELY \$700,000 IN DEVELOPMENT COSTS WILL BE INCURRED.

APPROXIMATELY \$300,000 WILL BE REQUIRED TO EXPEDITE EQUIPMENT PROCUREMENT TO REVERT TO EXISTING PROGRAM PLAN.

NO OJT TIME WILL BE SAVED.

STANDBY EQUIPMENT - THIS OUTCOME WILL PRODUCE A NEGATIVE EFFECT ABOUT HALF OF THAT OF OUTCOME B.

FLEXIBILITY IN TRAINING PROGRAM DEVELOPMENT - THIS OUTCOME WILL BE 2 TO 3 TIMES AS NEGATIVE AS OUTCOME B.

D - NEUTRAL OUTCOME. PRESENT STATE CONTINUES TO EXIST.

FIGURE III-15. SCEN FILE EXAMPLE

TAEG REPORT NO. 40

TRER (Tree Results). The decision variables calculated during the process of folding back the decision tree are stored in this file. The variables to be stored in this file are discussed later in the Decision Analysis section. They are a summary of the information printed on the Decision Tree Report DT01 which is an output of Program P60. Each record contains the input and calculated values associated with a single decision alternative; i.e., the alternative with NO RISK PKG, and up to nine RISK PKG alternatives. Various calculational runs can be stored and are given a unique sequence number.

The format of this file is as follows:

Pos	1- 2	Calculational Sequence Run Number - Up to 100 sequences (00-99) can be stored, the 00 sequence will be the baseline run from the data stored in the CMR, RRPK, and VARF files.
Pos	3	Risk Package Number within Sequence Run Number - 0 represents the NO RISK PKG alternative. 1-9 represent the nine possible RISK PKG conditions.
Pos	4	Rank of Alternative
Pos	5- 13	Utility of Outcome A
Pos	14- 22	Utility of Outcome B
Pos	23- 26	Probabilities X and Z
Pos	27- 35	Value X
Pos	36- 44	Value Z
Pos	45- 53	Utility of Outcome C
Pos	54- 57	Probabilities W and Y
Pos	58- 66	Value W
Pos	67- 75	Value Y
Pos	76- 84	Utility of Outcome D
Pos	85- 93	Value of PSUCC Path
Pos	94- 102	Value of PFAIL Path
Pos	103- 104	Probability of Project Success
Pos	105- 113	Value Before Risk Package
Pos	114- 122	Cost of Risk Package
Pos	123- 131	Value of Decision Variable

TAEG REPORT NO. 40

Pos	132- 133	Blank
Pos	134- 255	Descriptive Data indicating run conditions. Pos 134-141 of the NO RISK PKG alternative (0 in Col 3) for each Sequence Run Number will have the date of the run stored as MM/DD/YY.

ALTP (Alternative Projects). This file stores the project identifiers for potential alternatives to the proposed innovation. Alternative projects will be described in identical fashion to the primary innovation. The contents of this file will identify the projects which may be compared by the financial analysis routine. Up to five alternative project numbers may be stored.

The format of the file which can be inputted by card is as follows:

Pos	1- 5	1st Alternative Project ID; e.g., PN124
Pos	6	Blank
Pos	7- 11	2nd Alternative Project ID
Pos	12	Blank
Pos	13- 17	3rd Alternative Project ID
Pos	18	Blank
Pos	19- 23	4th Alternative Project ID
Pos	24	Blank
Pos	25- 29	5th Alternative Project ID

An example of the contents of this file is shown in Figure III-16.

FINR (Financial Results). The outputs of the financial analysis routine comparing various alternative innovation proposals are stored in this file. The variables to be stored in this file are discussed later in the Financial Analysis section. They are a summary of the information printed on the Financial Analysis Report FA01 which is an output of Program P63. The contents of this file are printed on the Financial Analysis Summary Report FA02. Various calculational runs can be stored and given a unique sequence number.

The format of this file is as follows:

Pos	1- 2	Calculational Sequence Run Number - Up to 100 sequences (00-99) can be stored, the 00 sequence will be the baseline run from the data stored in the CMR files.
Pos	3	Sequence Number (0-5) relating to sequence of project number in ALTP file being compared with the primary project. A 0 sequence number is the data on the primary project.

TAEG REPORT NO. 40

PAGE NUMBER : 1

SOURCE CARD LISTING FOR
**ALTP

**ALTP
PN124 PN125 PN126 PN127 PN128

FIGURE III-16. ALTP FILE EXAMPLE

?

TAEG REPORT NO. 40

Pos	4- 8	Project Identifier; e.g., PN123 for primary project (0 in Pos 3), PN124 for first alternative project (1 in Pos 3), etc.
Pos	9- 10	Project Life in Years
Pos	11- 16	Total Present Value (PV) of New Investment (\$K)
Pos	17- 22	Total PV of Recurring Cost/Savings (\$K)
Pos	23- 28	Net Present Value (\$K)
Pos	29- 30	Discount Rate (Percent)
Pos	31- 34	Savings/Investment Ratio
Pos	35- 37	Rate of Return on Investment
Pos	38- 43	Uniform Annual Cost
Pos	44- 45	Blank
Pos	46- 255	Descriptive data indicating run conditions. Pos 46-53 of the first record in every sequence (0 in Col 3) will have the date of the run stored as MM/DD/YY.

Project Data Base Application Summary. The files outlined for the project data base will contain data associated with a single analysis of the proposed innovation. Data input and computational changes can be made and stored until the assessor is satisfied with the results at that point in time. No attempt is made to store historical data, although this can be accomplished merely by copying each of the project files under a different identifier. The intent, however, is to produce a project report reflecting the assessment results at a point in time. If subsequent reassessment is desirable because factors or conditions have changed, new data input and computational results will be written over previously stored data.

ETAM PROCESSING SEQUENCE. Two major processing sequences are involved in the use of ETAM. These are in addition to the processing required to initially establish the project data base through card input. The first major sequence is Range-of-Effect. In Range-of-Effect, the assessor identifies search descriptors which will be matched to the abbreviated data bases in order to discover entities; i.e., courses, vehicles, and job/tasks, that may have potential application for the proposed innovation. Initial search descriptors can be entered into the REC, REV, and REJ files via card. The assessor can then interactively refine these search descriptors based upon search results. If the matched entities do not appear appropriate, the assessor can interactively add or delete to create a final entity list which will be the basis for obtaining additional data for the assessment process. The output of the Range-of-Effect processing sequence is a list of entities about which additional data must be collected. The entity lists, along with preprinted data collection forms, are forwarded to the appropriate Navy source in order to obtain these additional data. The data collected are returned, punched into cards, and loaded into extract files EXC, EXV, EXJ, and EXD. This process completes the Range-of-Effect portion of ETAM.

The second major ETAM processing sequence involves an assessment of the innovation. The Assessment sequence involves the application of the apparent benefit pattern, accruing from the innovation, to the quantitative and qualitative variables which will be evaluated during the Assessment processing sequence. With the benefit pattern established, cost models can be run and the results stored for subsequent use by either the Decision Analysis or the Financial Analysis programs. During the Decision Analysis part of the Assessment program, the assessor interactively assesses certain decision tree parameters in order to calculate decision variables for potential decision routes. In the Financial Analysis part of the Assessment program, certain financial factors are calculated which gives the decision maker a different perspective in evaluating the innovation than was gained from the Decision Analysis program. These two programs comprise the major part of the Assessment processing sequence. Following is a brief description of each of the steps which the assessor can take as a part of the ETAM innovation evaluation process.

Figure III-17 provides a descriptive summary of the various ETAM steps. The figure includes references to project data base files and programs which are an integral part of the ETAM processing sequence.

Create Project Files. At the inception of the project, as much information as is available should be entered into the project file. Thirteen of the Project Data Base files can be created from punched cards in batch mode. They can subsequently be revised by reentering the new file content via card, or interactively modifying any file using the National CSS Edit program.

- o Operation: Batch or Interactive
- o Files : ID, REC, REV, REJ, EXD, BPT, RKP, RRPJ, RRPK, VQAL, VARF, SCEN, ALTP
- o Programs : P17

Review Project Files. Project descriptive data is reviewed by the assessor. This could include reference to previously printed project data as well as to information on alternative projects. This is not necessarily limited to a review of the ID file.

- o Operation: Manual
- o Files : ID, REC, REV, REJ, BPT, RKP, RRPJ, VQAL, SCEN, ALTP
- o Programs : P1 to print Project Data Base files (if not already available).

Refine Search Descriptors. The search descriptors initially identified for the innovation can be refined interactively by the assessor in order to create a final pattern used to search and obtain additional information in the abbreviated data bases.

- o Operation: Interactive
- o Files : REC, REV, REJ, SARG
- o Programs : P2

Search. The results of the refinement of the search parameters in files REC, REV, and REJ are used to search the abbreviated data bases (Course, Job/Task, and Vehicles) for matching descriptors. The results are stored in a temporary file for subsequent refinement by the assessor.

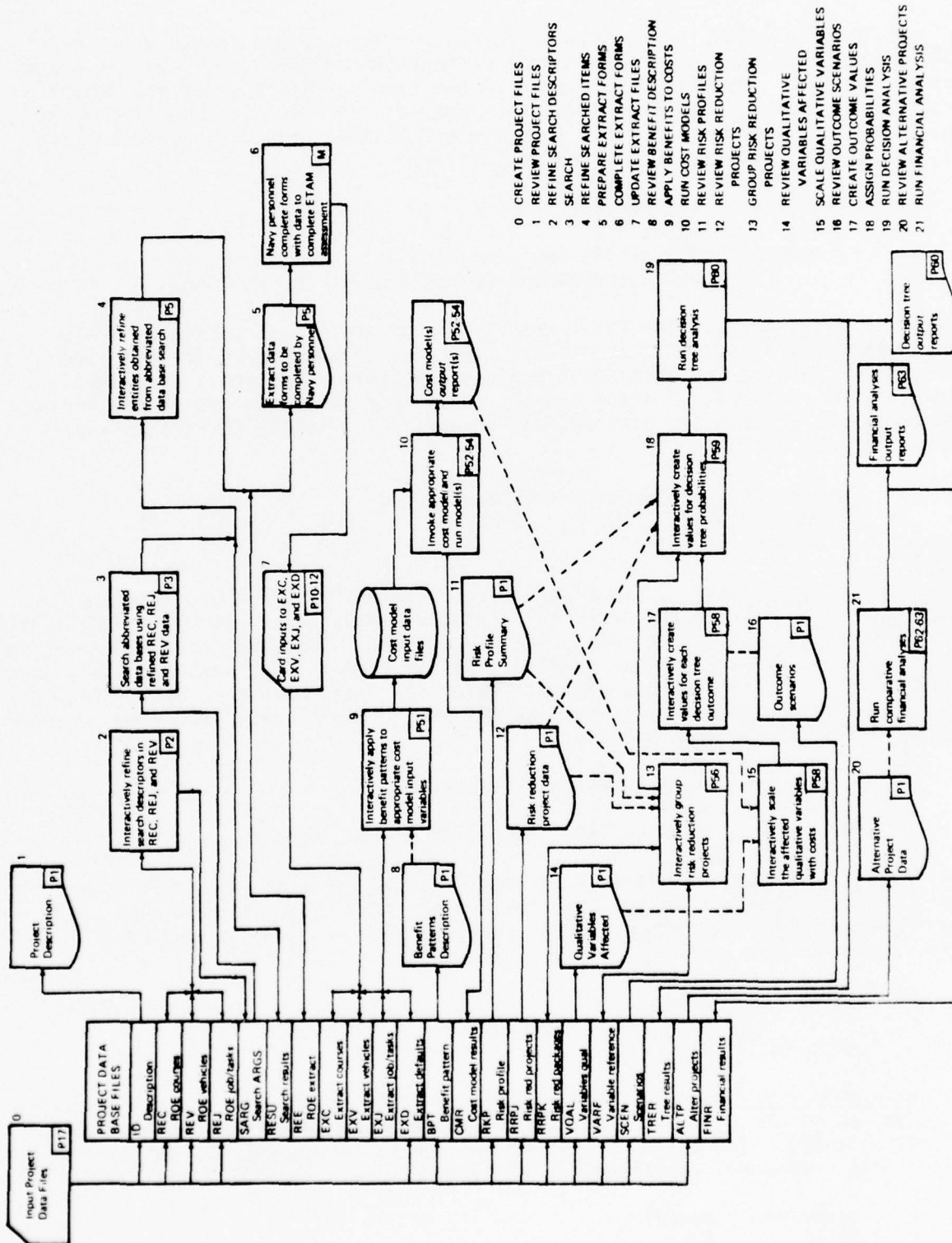

- 0 CREATE PROJECT FILES
- 1 REVIEW PROJECT FILES
- 2 REFINE SEARCH DESCRIPTORS
- 3 SEARCH
- 4 REFINE SEARCHED ITEMS
- 5 PREPARE EXTRACT FORMS
- 6 COMPLETE EXTRACT FILES
- 7 UPDATE EXTRACT FILES
- 8 REVIEW BENEFIT DESCRIPTION
- 9 APPLY BENEFITS TO COSTS
- 10 RUN COST MODELS
- 11 REVIEW RISK PROFILES
- 12 REVIEW RISK REDUCTION PROJECTS
- 13 GROUP RISK REDUCTION PROJECTS
- 14 REVIEW QUALITATIVE VARIABLES AFFECTED
- 15 SCALE QUALITATIVE VARIABLES
- 16 REVIEW OUTCOME SCENARIOS
- 17 CREATE OUTCOME VALUES
- 18 ASSIGN PROBABILITIES
- 19 RUN DECISION ANALYSIS
- 20 REVIEW ALTERNATIVE PROJECTS
- 21 RUN FINANCIAL ANALYSIS

FIGURE III-17. ETAM PROCESSING SEQUENCE

TAEG REPORT NO. 40

- o Operation: Interactive
- o Files : SARG, ABBREVIATED DATA BASE, RESU
- o Programs : P3

Refine Searched Items. The entities in the abbreviated data bases which match the search parameters are reviewed and refined by the assessor. This is accomplished through interactive reference to the temporary file where the search results are stored. Additions and deletions made at this time are flagged and the final results are (1) stored in project file REE, and (2) printed for transmittal to other Navy personnel for completion.

- o Operation: Interactive
- o Files : RESU, REE
- o Programs : P5A prints the search results
P5B accesses the search results for editing.

Prepare Extract Forms. The final results of the search and subsequent interactive refinement produce the entities potentially impacted by the proposed innovation. Before the assessment process can begin, additional data will generally be required. Printed extract forms onto which the additional information can be written are prepared and forwarded to the appropriate Navy personnel for completion.

- o Operation: Interactive and Manual
- o Files : REE
- o Programs : P5C

Complete Extract Forms. Lists of entities obtained through the search and subsequent edit will be forwarded to responsible Navy functions where additional data regarding costs, usage, etc., can be obtained. Training information source would be Chief Naval Education and Training for NITRAS data, vehicle data source would be the Naval Training Equipment Center for Training Device Statistical Data, and the job/task source would be the Bureau of Personnel for Navy Occupational Task Analysis Program data.

- o Operation: Offline Batch or Manual
- o Files : None
- o Programs : Tape Utility, Report Generator, etc.

Update Extract Files. Additional information entered on the printed extract forms is keypunched and loaded into the project files EXC, ECV, and EXJ. Where certain data are not available, an entry will be made in the EXD file to indicate the appropriate default condition.

- o Operation: Batch
- o Files : EXC, EXV, EXJ, EXD
- o Programs : P10, P11, P12, P17

Review Benefit Description. A pattern of potential benefits associated with the introduction of the proposed innovation will have been described and stored in project file BPT. The assessor reviews these data in preparation for modifying appropriate cost model variables.

- o Operation: Manual
- o File : BPT
- o Programs : P1 to print BPT file (if not already available).

Apply Benefit to Costs. The descriptive benefit pattern must be quantitatively defined by the assessor to the appropriate cost model. This is accomplished by interactively operating upon the cost model input variables prior to running the model(s). This step results in the creation of a temporary file containing cost model input data.

- o Operation: Interactive
- o Files : EXC, EXV, EXJ, COST MODEL INPUT
- o Programs : P51

Run Cost Models. The assessor now invokes the appropriate cost model(s) and the model outputs are printed and stored in project file CMR.

- o Operation: Interactive
- o Files : COST MODEL INPUT, EXD, CMR
- o Programs : P51, P52, P53, P54

Review Risk Profiles. The next major ETAM stage is assessment and introduction of risk factors. The assessor prepares for this part of the process by reviewing the contents of project file RKP which contains risk profiles for each of the risk categories; e.g., state-of-the-art, technical support, etc.

- o Operation: Manual
- o Files : RKP
- o Programs : P1 to print RKP file (if not already available).

Review Risk Reduction Projects. A number of projects will have been structured to reduce the potential risks in each of the risk categories associated with the implementation and use of the innovation. The assessor reviews these in association with the risk profiles previously identified.

- o Operation: Manual
- o Files : RKP, RRPJ
- o Programs : P1 to print RKP and RRPJ files (if not already available).

Group Risk Reduction Projects. All of the risk reduction projects identified may not be economically feasible to undertake. A better cost-benefit effect may be obtained by selecting a group of the risk projects for implementation. Available resources will undoubtedly be a major determinant of the number of projects undertaken. The assessor reviews the risk profiles and risk reduction projects (project files RKP and RRPJ) and identifies various packages of projects which appear reasonable to undertake. Interactively, the groupings can be made to which the assessor must attach certain probabilities and probability ranges (confidence ranges). The first probability and confidence range to be estimated is associated with the expected success of the project package itself. If unique talent is required to undertake the projects, this probability would be low. The second probability estimate is associated with the expected success in implementing the innovation. An implementation success probability will be estimated considering no risk reduction project package is undertaken. Assumedly, each package of projects identified will improve this probability estimate to some degree. A confidence range is also estimated. The third probability estimated is that of success in obtaining acceptance by the using system. Again, this probability will be estimated under the assumption of no risk reduction project packages. Then, a new probability will be estimated for each package considering its effect upon the using system's acceptance of the innovation. This estimate will include a confidence range.

TAEG REPORT NO. 40

- o Operation: Interactive
- o Files : RKP, RRPJ, RRPK
- o Programs : P56 (P59 may be called)

Review Qualitative Variables Affected. The descriptions of the qualitative variables, e.g., morale, safety, etc., are reviewed by the assessor in preparation for the scaling operation. These descriptions are stored in project file VQAL.

- o Operation: Manual
- o Files : VQAL
- o Programs : P1 to print VQAL file (if not already available).

Scale Qualitative Variables. In this step, the assessor develops relative values for each of the relevant qualitative variables as well as the cost/savings variable previously calculated. This is an interactive process, with the assessor being prompted into estimates of the present and potential states at each outcome of each relevant variable. An importance value is assigned to each attribute (variable) which permits subsequent relevant values (e.g., equivalent dollars) to be attached to each attribute at each possible outcome.

- o Operation: Interactive
- o Files : CMR, VQAL, VARF
- o Programs : P58

Review Outcome Scenarios. The assessor must now visualize the effects of introducing the innovation in each of the potential outcome situations, i.e., (1) it is implemented and accepted by the using system, (2) it is implemented but fails to gain acceptance by the using system, (3) it fails to be implemented after being accepted, or (4) it is rejected. These scenarios if previously developed are described in project file SCEN.

- o Operation: Manual
- o Files : SCEN
- o Programs : P1 to print SCEN file (if not already available).

Create Outcome Values. An equivalent dollar value or utility is now developed for each of the four decision tree outcome states. This is performed interactively by the assessor using costs from previous model runs, liability costs or shutdown costs developed for each outcome where the innovation is accepted but does not succeed in either implementation or using system acceptance, point estimates and importance estimates identified in the scaling of qualitative variables step, and judgments developed during the interactive process. The final outcome totals will be used in the folding back of the decision tree to develop the decision variables.

- o Operation: Interactive
- o Files : CMR, VARF, SCEN
- o Programs : P58

Assign Probabilities. The remaining input to the decision tree is the finalized set of probabilities associated with each mode of the tree. These were initially developed in conjunction with the step in which risk reduction projects were grouped into various packages. The assessor on an interactive basis reviews and refines these probabilities.

- o Operation: Interactive
- o Files : VARF, SCEN
- o Programs : P59

Run Decision Analysis. The assessor invokes the decision tree evaluator which computes the expected value for each possible decision path. The computation simply folds back the tree based upon the outcome values and the node probabilities. A decision variable is calculated for the decision path where the proposed innovation is accepted without performing any of the risk reduction projects, as well as for each decision path involving a group or package of risk reduction projects which would be expected to be undertaken. The results of the decision tree evaluator program run are printed and also stored in the project file TRER.

- o Operation: Interactive
- o Files : CMR, RRPK, VARF, TRER
- o Programs : P60

Review Alternative Projects. If alternatives to the primary innovation have been proposed, they should be reviewed by the assessor at this time. It is assumed that most of the previous steps will have been considered for each of the alternative proposals. If calculation of decision tree variables for an alternative proposal indicates in of itself it should be rejected; it would not generally be considered in any comparative financial analysis with the primary proposal or other promising alternative proposals. The identifiers for alternative proposals to be reviewed at this time are stored in project file ALTP.

- o Operation: Manual
- o Files : ALTP, OTHER PROJECT DATA BASE FILES REFERENCED BY ALTP
- o Programs : P1 to print ALTP and other PROJECT DATA BASE files (if not already available).

Run Financial Analysis. This step takes the incremental cost/savings data associated with each proposed innovation (primary and alternatives) and calculates a set of financial measures (e.g., rate of return, etc.) when comparing the proposal to the existing system. Marginal measures of return can be calculated comparing two proposals. The assessor sets up the run conditions and invokes the financial analysis routine. The results of these program runs are stored in project file FINR.

- o Operation: Interactive
- o Files : ALTP, CMR (from Primary and Alternative projects), FINR
- o Programs : P62, P63

Processing Step Summary. The ETAM steps have described more or less in a logical sequence for performance by the assessor. A major intent in developing the ETAM procedures was to foster an efficient as well as effective decision process. This requires that the steps previously outlined be performed iteratively with increasing amounts of data, the collection of which appears justified at each iterative stage. Therefore, the assessor should take advantage of the capability for randomly assessing any of the routines and running them given some level of valid data inputs can be developed.

ETAM PROGRAM FUNCTIONS

The ETAM process sequence previously described is a composite of manual, computer batch, and computer interactive steps which require system files, project data base files, and computer programs. The Project Data Base files were outlined in the preceding section. The programs which were developed for the ETAM Range-of-Effect function are summarized here, and documented in detail in Appendix D. This section outlines the design requirements for completing the programming development of the ETAM Assessment function.

ETAM CONTROL EXEC. ETAM programs can be run through individual EXEC's which call each program. For example, entering RUNP1 PN123 at the terminal would call the RUNP1 EXEC supplying it with the parameter PN123 as the Project Identifier. The RUNP1 EXEC would in turn call Program P1 which would permit the files in the Project Data Base to be printed. However, the ETAM processing sequence can be controlled through the ETAM EXEC which is called by entering ETAM at the terminal. The ETAM EXEC prompts the user in the selection of the project and programs to be accessed. The logic of the ETAM EXEC is shown in Figure III-18. Each of the terminal displays is numbered 1 through 8. The content of each display is shown in Figure III-19. Since programs for the Assessment function are not developed, the user will have displayed "PROGRAM NOT INSTALLED" anytime an attempt is made to call MODEL, RISK, DECISION or FINANCIAL (Assessment-Select Option, Disp #7 in Figure III-19).

Besides permitting selection of the two primary ETAM functions; i.e., Range-of-Effect or Assessment, the ETAM EXEC 1) checks for existence of the Project Identifier inputted by the user, 2) permits generation of a new Project Data Base by calling Program P17, 3) permits printing of the Project Data Base by calling Program P1, or 4) displays instructions for the user.

Project Identifier Existence. When the ETAM EXEC is called by entering ETAM, a Project ID is requested. The existence of the ID entered is checked through a system procedure within the ETAM EXEC which looks for an ID File Type with the Project ID as the File Name. The system requires that all Project ID's begin with a non-numeric character, however, the ETAM convention is to begin each Project ID with the characters PN and follow it with three numeric designators; e.g., PN123. No system checks will ensure this format is followed by the user, although the EXEC prompting message provides this format in the example. Thus, if an ID file exists with the entered Project ID, the user can continue through the ETAM evaluation process. If the Project ID does not already exist, the user will be given the option of generating a new Project Data Base using Program P17.

Program P17 (Project Generation). In order to generate a new Project Data Base, a LOAD File Type with the new Project ID as the File Name must exist in the user's workspace. It may have been entered through an OFFLINE READ of the cards constituting the project files, or it could have been created from the terminal using the NCSS Edit Procedures.

The first card of the LOAD file must contain INIT in the first four positions. The second card of the LOAD file must contain **ID in the first four positions. The third card must contain the Project ID anywhere within the first ten positions, and should contain the name of the new project in Pos 11-80. Figure III-20

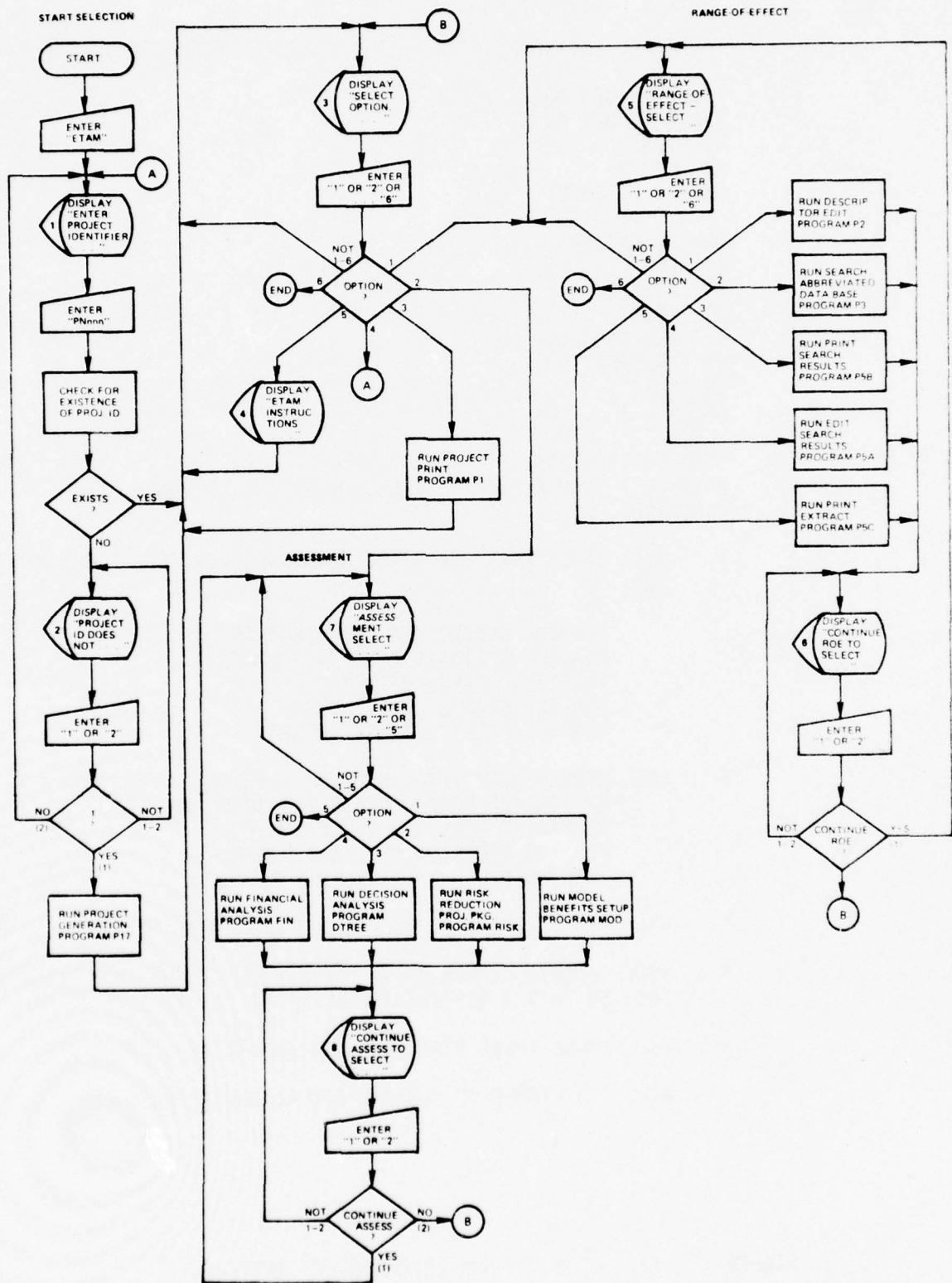

FIGURE III-18. ETAM CONTROL EXEC

TAEG REPORT NO. 40

<u>DISP #</u>	<u>DISPLAY CONTENT</u>
1	ENTER PROJECT IDENTIFIER, E.G., PN123 (5 CHARACTERS)
2	PROJECT DOES NOT EXIST. GENERATE NEW FILE? ? ? 1) YES 2) NO ENTER: 1 OR 2
3	SELECT OPTION. 1) ROE 2) ASSESS 3) PRINT 4) NEW PROJECT 5) INSTRUCTIONS 6) QUIT ENTER: 1 ... 6
4	ETAM INSTRUCTIONS OPTIONS 1 THRU 6 PERMIT SELECTION OF THE FOLLOWING ETAM FUNCTIONS. 1 WILL CAUSE ENTRY INTO THE ETAM RANGE-OF-EFFECT FUNCTION FOR: RUNNING DESCRIPTOR EDIT PROGRAM SEARCHING ABBREVIATED DATA BASES PRINTING SEARCH RESULTS RUNNING SEARCH EDIT PROGRAM RUNNING PRINT EXTRACT PROGRAM 2 WILL CAUSE ENTRY INTO THE ETAM ASSESSMENT FUNCTION FOR: SETTING UP MODEL INPUTS FOR MODEL RUN PACKAGING RISK REDUCTION PROJECTS RUNNING DECISION ANALYSIS PROGRAMS RUNNING FINANCIAL ANALYSIS PROGRAMS 3 WILL PERMIT PRINTING OF PROJECT DATA BASE FILES 4 WILL CAUSE A RETURN TO THE BEGINNING OF THE ETAM CONTROL EXEC SO THAT A DIFFERENT PROJECT ID CAN BE ENTERED 5 WILL CAUSE THESE ETAM INSTRUCTIONS TO BE REPRINTED 6 WILL END ETAM EXEC CONTROL AND RETURN TO NCSS CONTROL

FIGURE III-19. ETAM CONTROL EXEC DISPLAY PATTERNS

DISP #

DISPLAY CONTENT

- 5 RANGE-OF-EFFECT - SELECT OPTION.
1) EDIT DESCRIPTOR
2) SEARCH
3) PRINT SEARCH
4) EDIT SEARCH
5) PRINT EXTRACT
6) QUIT
ENTER: 1 ... 6
- 6 CONTINUE ROE TO SELECT OTHER ROUTINES? ? ?
1) YES
2) NO
ENTER: 1 OR 2
- 7 ASSESSMENT - SELECT OPTION.
1) MODEL
2) RISK
3) DECISION
4) FINANCIAL
5) QUIT
ENTER: 1 ... 5
- 8 CONTINUE ASSESS TO SELECT OTHER ROUTINES? ? ?
1) YES
2) NO
ENTER: 1 OR 2

FIGURE III-19. ETAM CONTROL EXEC DISPLAY PATTERNS (Cont'd)

CSS

08.43.16 RUNP17 PN123

PROJECT NAMED PN123 DOES NOT YET EXIST,
IS THIS CORRECT? (RESPOND YES OR QUIT)

YES

OUTPUT TO GO TO TERMINAL, OFFLINE PRINTER, BOTH, OR QUIT?
ENTER TERM, PRTR, BOTH, OR QUIT
PRTR

SEXECUTION:

PROJECT FILE INITIALIZATION PROGRAM IS STARTING

LOAD OF PROJECT FILETYPE : ID - PROJECT DESCRIPTION
LOAD OF PROJECT FILETYPE : REC - COURSES ROE SEARCH ARGUMENTS
LOAD OF PROJECT FILETYPE : BPT - BENEFIT PATTERN
LOAD OF PROJECT FILETYPE : RKP - RISK PROFILE
LOAD OF PROJECT FILETYPE : RRPJ - RISK REDUCTION PROJECTS
LOAD OF PROJECT FILETYPE : SCEN - SCENARIOS
LOAD OF PROJECT FILETYPE : RRPK - RISK REDUCTION PACKAGES
LOAD OF PROJECT FILETYPE : VQAL - VARIABLES **QUALITATIVE**
LOAD OF PROJECT FILETYPE : VARF - VARIABLE REFERENCES
LOAD OF PROJECT FILETYPE : ALTP - ALTERNATE PROJECTS

FILE : REJ HAS BEEN INITIALIZED WITH ONE (1) BLANK RECORD

FILE : REV HAS BEEN INITIALIZED WITH ONE (1) BLANK RECORD

FILE : EXD HAS BEEN INITIALIZED WITH ONE (1) BLANK RECORD

*** ALL DATASETS INITIALIZED ***

*** TOTAL NUMBER INPUT CARDS READ : 461 ***

PROJECT FILE INITIALIZATION PROGRAM IS NOW TERMINATING

FIGURE III-20. EXAMPLE OF PROGRAM P17

shows an example run of Program P17 which, in this case, was called by the RUNP17 EXEC with the new Project ID as a parameter. The Project ID parameter would have been passed automatically if the RUNP17 EXEC were called by the ETAM EXEC.

Thirteen file types can be loaded using Program P17. These are listed in Figure III-20. Any of these files for which data do not exist in the LOAD File Type will be automatically initialized at this time by Program P17. When data are available for the missing files, or previously created files are to be modified, Program P17 will be used again. The difference between this process and the initial Project Data Base generation procedure is that the LOAD File Type for an update will not contain the INIT card.

Program P17 gives the user the option of listing the new Project Data Base contents at either the terminal or the printer, or both. The user should obtain the initial Project Data Base listing in this manner.

Program P1 (Project Data Base Print). Program P1 permits the user to list any one or all of twenty-one of the twenty-two files in the Project Data Base (the SARG file is not listed). The output can be directed to either the terminal or offline printer, or both. While the option to print ALL Project Data Base files is available to the user, it can not be used until all the Project Data Base files printed by Program P1 have been opened. Figure III-21 shows an example run of Program P1 as called by the RUNP1 EXEC. When ETAM is entered through the ETAM EXEC, running of Program P1 is one of the select options.

ETAM Instructions. The instructions which will be displayed to the user were shown in Figure III-19, Disp #4.

ETAM RANGE-OF-EFFECT. The Range-of-Effect is a major ETAM function which attempts to identify potential applications for a proposed innovation. The methodology is based upon a capability of assigning descriptors to the innovation which serve as search parameters to data bases having courses, vehicles, and job/tasks to which the same set of descriptors have been associated. The descriptors were developed in such a way that a match between a search descriptor assigned to the innovation, and an entity index descriptor assigned to a course, for example, should represent a potential application for the innovation. The descriptor sets are discussed in Appendix A of this report. The purpose of this section is to describe the programs for accomplishing the major Range-of-Effect objectives, which are to:

1. Assign descriptors to the proposed innovation based upon the descriptor taxonomies outlined in Appendix A.
2. Search the Abbreviated Data Bases for courses, vehicles or job/tasks (whichever are appropriate to the potential application of the innovation), and select a set of entities which match the search parameter logic.
3. Print a list of the selected entities, then refine the list by adding or deleting items based upon a broader perspective of the entity characteristics than is embodied in the index descriptors, and finally print the list of entities requiring additional data for the ETAM Assessment phase.

CSS

09.18.59 RUNP1 PN123

PROJECT NAMED PN123 ALREADY EXISTS,
IS THIS CORRECT? (RESPOND YES OR QUIT)

YES

\$\$\$\$\$

GENERAL-PURPOSE PROJECT FILE PRINT
PROGRAM IS NOW STARTING...

*** ENTER FILETYPE FOR OUTPUT, MENU, OR QUIT ***
_MENU

PROJECT FILETYPES FOR OUTPUT ARE :

ID - PROJECT DESCRIPTION
EXD - EXTRACT DEFAULTS
BPT - BENEFIT PATTERN
RKP - RISK PROFILE
RRPJ - RISK REDUCTION PROJECTS
RRPK - RISK REDUCTION PACKAGES
VQAL - VARIABLES QUALITATIVE
VARF - VARIABLE REFERENCES
SCEN - SCENARIOS
ALTP - ALTERNATE PROJECTS
REC - COURSES ROE SEARCH ARGUMENTS
REV - VEHICLES ROE SEARCH ARGUMENTS
REJ - TASKS ROE SEARCH ARGUMENTS
RESU - ROE TOTAL SEARCH RESULTS
REE - ROE SEARCH RESULTS
EXC - EXTRACT DB - COURSES
EXJ - EXTRACT DB - JOBTASKS
EXV - EXTRACT DB - VEHICLES
CMR - COST MODEL RESULTS
TRER - TREE RESULTS
FINR - FINANCIAL RESULTS

FIGURE III-21. EXAMPLE OF PROGRAM P1

*** ENTER FILETYPE FOR OUTPUT, MENU, OR QUIT ***
_REC

OUTPUT TO GO TO TERMINAL, OFFLINE PRINTER, BOTH, OR QUIT
ENTER TERM, PRTR, BOTH, OR QUIT
_BOTH

PAGE NUMBER : 1

LISTING OF PROJECT FILE CONTENTS
PH123 / REC - COURSES ROE SEARCH ARGUMENTS

30 OPERATIONS
31 MAINTENANCE
40 EQUIPMENT & OBJECTS USED: REAL
64 PROCEDURE FOLLOWING
-80 ORIENTATION, FAMILIARIZATION
-81 TASK NOMENCLATURE, IDENTs, LOCATIONS, FACTS, RULES
82 TASK FORMATS AT CONCEPTUAL LEVEL
83 PROCEDURES AT VERBAL LEVEL ONLY
84 TASK COMPONENTS WITH GUIDANCE
85 ENTIRE JOB-TASK PROCEDURALLY AT BARELY ACCEPTABLE MASTERY
86 HIGHLY PROFICIENT IN WORK CONTEXT
A TOTAL OF 11 RECORDS ARE PRESENT
WITHIN THIS FILE

FIGURE III-21. EXAMPLE OF PROGRAM P1 (Cont'd)

TAEG REPORT NO. 40

*** ENTER FILETYPE FOR OUTPUT, MENU, OR QUIT ***
_RESU

OUTPUT TO GO TO TERMINAL, OFFLINE PRINTER, BOTH, OR QUIT
ENTER TERM, PRTR, BOTH, OR QUIT
_BOTH

PAGE NUMBER : 2

LISTING OF PROJECT FILE CONTENTS
PN123 / RESU - ROE TOTAL SEARCH RESULTS

THE FOLLOWING IS ROE RESULT DATA FOR COURSES
NUM ORIGIN CIN CDP COURSE TITLE

NUM	ORIGIN	CIN	CDP	COURSE TITLE
1	DELETED	A1020060	NONE	(NO ABBREVIATED FILE DATA AVAILABLE)
2	DELETED	A1020093	NONE	(NO ABBREVIATED FILE DATA AVAILABLE)
3	DELETED	A1020095	NONE	(NO ABBREVIATED FILE DATA AVAILABLE)
4	ORIGINAL	A1930050	2213	INERT NAV PRINC
5	ORIGINAL	A2420010	6529	IS A
6	ORIGINAL	A4120010	6078	EA-A
7	ORIGINAL	A4120010	6287	EA A

FIGURE III-21. EXAMPLE OF PROGRAM P1 (Cont'd)

TAEG REPORT NO. 40

8	ORIGINAL	A4310011	1035	EOD BASIC NAVY
9	ORIGINAL	A4310014	1036	EOD REFR NAVY
10	ORIGINAL	A4330019	2040	MASTER DIVQUAL
11	ORIGINAL	A4330025	2082	DIVER FIRST
12	ORIGINAL	A4910014	2046	RADIUM REMOV OPS
13	ORIGINAL	A5510019	0133	CAR HAND BAS
14	ORIGINAL	A5510027	3931	UNREP MECH/HYD
15	ORIGINAL	A5510068	0134	FORK LIFT OPER
16	ORIGINAL	A5800016	6053	CTO A
17	ORIGINAL	A6510020	5399	1200 PSI BT
18	ORIGINAL	A6520050	5224	OX GENR 6L160P
19	ORIGINAL	A6520068	463E	SOLAR GAS TURBIN
20	ORIGINAL	A6700011	3078	WATCH REPAIR
21	ORIGINAL	A7010027	337M	WELD/HPRES PIPE
22	ORIGINAL	A7200013	466Z	UT-J
23	DELETED	B3030051	NONE	(NO ABBREVIATED FILE DATA AVAILABLE)
24	ORIGINAL	C 003722	2887	TA4JF FAM PILOTS
25	ORIGINAL	C 003722	9007	TA4JF FAM PILOTS
26	ORIGINAL	C 003722	9009	TA4JF FAM PILOTS

FIGURE III-21. EXAMPLE OF PROGRAM P1 (Cont'd)

TAEG REPORT NO. 40

PAGE NUMBER : 3

LISTING OF PROJECT FILE CONTENTS
 PN123 / RESU - ROE TOTAL SEARCH RESULTS

THE FOLLOWING IS ROE RESULT DATA FOR COURSES

NUM	ORIGIN	CIN	CDP	COURSE TITLE
-----	-----	-----	-----	-----
27	ORIGINAL	C 003722	9010	TA4JF FAM PILOTS
28	ORIGINAL	C 003722	9738	TA4JF FAM PILOTS
29	ORIGINAL	C 2C3352	2576	UH1N A/C FAM/P/
30	ORIGINAL	C1003834	7529	AAS18 INT MAI
31	ORIGINAL	C1023793	7914	A7AB ATT HEADING
32	ORIGINAL	C1023793	7915	A7AB ATT HEADING
33	ORIGINAL	C1213011	346L	AWM23 RADIO FREQ
34	ORIGINAL	C1213011	544L	AWM23 RADIO FREQ
35	ORIGINAL	C6003472	340C	E2C WEA SYS FAM
36	ORIGINAL	C6023536	341D	54H6077 PROP INT
37	ORIGINAL	C6463103	7365	CVA/CV ALW SUPV
38	DELETED	D 2C0011	NONE	(NO ABBREVIATED FILE DATA AVAILABLE)
39	DELETED	E 2A1001	NONE	(NO ABBREVIATED FILE DATA AVAILABLE)
40	DELETED	E 2A1301	NONE	(NO ABBREVIATED FILE DATA AVAILABLE)
41	DELETED	E 2A1803	NONE	(NO ABBREVIATED FILE DATA AVAILABLE)
42	DELETED	E 2C0901	NONE	(NO ABBREVIATED FILE DATA AVAILABLE)
43	DELETED	E 2D0016	NONE	(NO ABBREVIATED FILE DATA AVAILABLE)
44	DELETED	E 2D0075	NONE	(NO ABBREVIATED FILE DATA AVAILABLE)

FIGURE III-21. EXAMPLE OF PROGRAM P1 (Cont'd)

TAEG REPORT NO. 40

45	DELETED	E6010210	NONE	(NO ABBREVIATED FILE DATA AVAILABLE)
46	DELETED	E6461641	NONE	(NO ABBREVIATED FILE DATA AVAILABLE)
47	DELETED	F7000010	NONE	(NO ABBREVIATED FILE DATA AVAILABLE)
48	DELETED	H 2E3710	NONE	(NO ABBREVIATED FILE DATA AVAILABLE)
49	DELETED	J1300645	NONE	(NO ABBREVIATED FILE DATA AVAILABLE)
50	ORIGINAL	J2210357	538Q	MULTI-THREAT TNG
51	ORIGINAL	J2330203	2637	ADV EW OP'S CRSE
52	ORIGINAL	J2430974	2181	IPC

PAGE NUMBER : 4

LISTING OF PROJECT FILE CONTENTS
 PN123 / RESU - ROE TOTAL SEARCH RESULTS

THE FOLLOWING IS ROE RESULT DATA FOR COURSES
 NUM ORIGIN CIN CDP COURSE TITLE

NUM	ORIGIN	CIN	CDP	COURSE TITLE
53	DELETED	J8000433	NONE	(NO ABBREVIATED FILE DATA AVAILABLE)
54	ORIGINAL	K2330066	205Y	SUB EW OP-ADV
55	DELETED	L1010024	NONE	(NO ABBREVIATED FILE DATA AVAILABLE)
56	ORIGINAL	L6610056	NONE	(NO ABBREVIATED FILE DATA AVAILABLE)
57	ORIGINAL	M198100E	NONE	(NO ABBREVIATED FILE DATA AVAILABLE)
58	ORIGINAL	N7010320	NONE	(NO ABBREVIATED FILE DATA AVAILABLE)
59	ORIGINAL	Q 2C0015	NONE	(NO ABBREVIATED FILE DATA AVAILABLE)
60	ORIGINAL	83000010	NONE	(NO ABBREVIATED FILE DATA AVAILABLE)
61	ORIGINAL	83000012	NONE	(NO ABBREVIATED FILE DATA AVAILABLE)
62	ADDED	A1010108	7654	WRA-4 CMB MA

A TOTAL OF 62 RECORDS ARE PRESENT
 WITHIN THIS FILE

FIGURE III-21. EXAMPLE OF PROGRAM P1 (Cont'd)

TAEG REPORT NO. 40

*** ENTER FILETYPE FOR OUTPUT, MENU, OR QUIT ***
_REE

OUTPUT TO GO TO TERMINAL, OFFLINE PRINTER, BOTH, OR QUIT
ENTER TERM, PRTR, BOTH, OR QUIT
_BOTH

\$

PAGE NUMBER : 5

LISTING OF PROJECT FILE CONTENTS
PN123 / REE - ROE SEARCH RESULTS

THE FOLLOWING IS ROE RESULT DATA FOR COURSES

NUM	ORIGIN	CIN	CDP	COURSE TITLE
1	ORIGINAL	A1930050	2213	INERT NAV PRINC
2	ORIGINAL	A2420010	6529	IS A
3	ORIGINAL	A4120010	6078	EA-A
4	ORIGINAL	A4120010	6287	EA A
5	ORIGINAL	A4310011	1035	EOD BASIC NAVY
6	ORIGINAL	A4310014	1036	EOD REFR NAVY
7	ORIGINAL	A4330019	2040	MASTER DIVQUAL

FIGURE III-21. EXAMPLE OF PROGRAM P1 (Cont'd)

TAEG REPORT NO. 40

8	ORIGINAL	A4330025	2082	DIVER FIRST
9	ORIGINAL	A4910014	2046	RADIUM REMOV OPS
10	ORIGINAL	A5510019	0133	CAR HAND BAS
11	ORIGINAL	A5510027	3931	UNREP MECH/HYD
12	ORIGINAL	A5510068	0134	FORK LIFT OPER
13	ORIGINAL	A5800016	6053	CTO A
14	ORIGINAL	A6510020	5390	1200 PSI BT
15	ORIGINAL	A6520050	5224	OX GENR 6L160P
16	ORIGINAL	A6520060	463E	SOLAR GAS TURBIN
17	ORIGINAL	A6700011	3078	WATCH REPAIR
18	ORIGINAL	A7010027	337M	WELD/HPRES PIPE
19	ORIGINAL	A7200013	466Z	UT-J
20	ORIGINAL	C 003722	2887	TA4JF FAM PILOTS
21	ORIGINAL	C 003722	9007	TA4JF FAM PILOTS
22	ORIGINAL	C 003722	9009	TA4JF FAM PILOTS
23	ORIGINAL	C 003722	9010	TA4JF FAM PILOTS
24	ORIGINAL	C 003722	9738	TA4JF FAM PILOTS
25	ORIGINAL	C 2C3352	2576	UH1N A/C FAM/P/
26	ORIGINAL	C1003834	7529	AAS18 INT MAI

FIGURE III-21. EXAMPLE OF PROGRAM P1 (Cont'd)

TAEG REPORT NO. 40

PAGE NUMBER : 6

LISTING OF PROJECT FILE CONTENTS
 PN123 / REE - ROE SEARCH RESULTS

THE FOLLOWING IS ROE RESULT DATA FOR COURSES
 NUM ORIGIN CIN CDP COURSE TITLE

NUM	ORIGIN	CIN	CDP	COURSE TITLE
27	ORIGINAL	C1023793	7914	A7AB ATT HEADING
28	ORIGINAL	C1023793	7915	A7AB ATT HEADING
29	ORIGINAL	C1213011	346L	AWM23 RADIO FREQ
30	ORIGINAL	C1213011	544L	AWM23 RADIO FREQ
31	ORIGINAL	C6003472	340C	E2C WEA SYS FAM
32	ORIGINAL	C6023536	341D	54H6077 PROP INT
33	ORIGINAL	C6463103	7365	CVA/CV ALW SUPV
34	ORIGINAL	J2210357	538Q	MULTI-THREAT TNG
35	ORIGINAL	J2330203	2637	ADV EW OP'S CRSE
36	ORIGINAL	J2430974	2181	IPC
37	ORIGINAL	K2330066	205Y	SUB EW OP-ADV
38	ORIGINAL	L6610056	NONE	(NO ABBREVIATED FILE DATA AVAILABLE)
39	ORIGINAL	M198100E	NONE	(NO ABBREVIATED FILE DATA AVAILABLE)
40	ORIGINAL	N7010320	NONE	(NO ABBREVIATED FILE DATA AVAILABLE)
41	ORIGINAL	Q 2C0015	NONE	(NO ABBREVIATED FILE DATA AVAILABLE)
42	ORIGINAL	83000010	NONE	(NO ABBREVIATED FILE DATA AVAILABLE)
43	ORIGINAL	83000012	NONE	(NO ABBREVIATED FILE DATA AVAILABLE)
44	ADDED	A1010108	7654	(NO ABBREVIATED FILE DATA AVAILABLE)

A TOTAL OF 44 RECORDS ARE PRESENT
 WITHIN THIS FILE

*** ENTER FILETYPE FOR OUTPUT, MENU, OR QUIT ***
 _QUIT

PROJECT-FILE PRINT PROGRAM IS NOW TERMINATING

FIGURE III-21. EXAMPLE OF PROGRAM P1 (Cont'd)

The programs which were developed to accomplish these objectives are:

- P2 - Interactive Search Designator Editor
- P3 - Range-of-Effect (ROE) Search Module
- P5A - Print of Raw ROE Results File
- P5B - Interactive Search Results Editor
- P5C - Print of ROE Search Results for Extract

Since these programs are developed and documented in Appendix D of this report, only the user-related functions of the programs are outlined here.

Program P2 (Interactive Search Designators Editor). Program P2 permits the user to edit the contents of the three Range-of-Effect descriptor files, REC, REV, and REJ. These may have been initially loaded when the Project Data Base was generated using Program P17, however, if this was not the case, the entire contents of these files can be entered using Program P2. Figure III-22 shows an example edit of the REC (COURSES) file. Here Program P2 was called by the RUNP2 EXEC with the Project ID, PN123, provided as a parameter. If Program P2 were entered from the ETAM EXEC, the Project ID would have been passed automatically to the RUNP2 EXEC.

The program requests the user to identify the file to be edited by entering either SELECT COURSES (for the REC file), SELECT VEHICLES (for the REV file), or SELECT TASKS (for the REJ file). The program then provides the user with a count of the present number of descriptors loaded in the file. When requested to "MAKE NEXT ACTION REQUEST" the user can enter PRINT, ADD dn (dn = descriptor number; e.g., 82), DELETE dn, SELECT another file (e.g., VEHICLES or TASKS), or FILE. FILE should only be entered after editing of all files has been completed since it terminates Program P2.

Program P3 (Range-of-Effect (ROE) Search Module). Program P3 is used to search the contents of the Abbreviated Data Base for entities which have index descriptors matching the search descriptors and logic provided by the contents of files REC, REV, and REJ. Figure III-23 shows an example of a run of Program P3. In this case it was called by the RUNP3 EXEC, however, it can also be selected as one of the options with the Range-of-Effect portion of the ETAM EXEC. No user interaction is required other than the verification that the Project ID exists. If no descriptors have been entered into REC, REV, or REJ, search of its corresponding Abbreviated Data Base will be bypassed. Program P3 prints out summary data of the search results as is shown in Figure III-23. Printing of the search results is accomplished by Program P5A as explained next.

Program P5A (Print of Raw ROE Results File). Program P5A prints the results of the Program P3 search of the Abbreviated Data Bases. Figure III-24 shows an example run of Program P5A as invoked by the RUNP5A EXEC. The user has the option of directing the output of this program to either the terminal or offline printer, or both. This decision is aided by the summary data provided by Program P3. If there are a significant number of entities, and the user can wait for the printed results to be received by mail, the output should be directed to the offline printer. As with Program P3, Program P5A provides a summary of the entities processed.

TAEG REPORT NO. 40

CSS

08.45.32 RUNP2 PN123

PROJECT NAMED PN123 ALREADY EXISTS,
IS THIS CORRECT? (RESPOND YES OR QUIT)

YES
\$\$\$

SEARCH DESCRIPTOR EDITOR RUN FOR PROJECT : PN123
3-D PROCEDURAL TRAINER

*** MAKE INITIAL ENTRY SELECT
_SELECT COURSES

*** COURSES SEARCH DESCRIPTORS SELECTED

*** 11 DESCRIPTORS NOW SELECTED

*** MAKE NEXT ACTION REQUEST
_PRINT

*** GROSS JOB CATEGORIES
30 OPERATIONS
31 MAINTENANCE

*** OBJECTIVE TASK VARIABLES AS MANIFEST IN THE TRAINING
40 EQUIPMENT & OBJECTS USED: REAL

*** TASK FUNCTIONS DOMINANT IN TRAINING
64 PROCEDURE FOLLOWING

*** STAGE OF LEARNING
-80 ORIENTATION, FAMILIARIZATION
-81 TASK NOMENCLATURE, IDENTs, LOCATIONS, FACTS, RULES
83 PROCEDURES AT VERBAL LEVEL ONLY
84 TASK COMPONENTS WITH GUIDANCE
85 ENTIRE JOB-TASK PROCEDURALLY AT BARELY ACCEPTABLE MASTERY
86 HIGHLY PROFICIENT IN WORK CONTEXT
87 UNUSUAL TASK CONDITIONS

*** MAKE NEXT ACTION REQUEST
_DELETE 87

*** COURSES DESIGNATOR NUMBER 87 HAS BEEN DELETED

*** MAKE NEXT ACTION REQUEST
_ADD 82

*** ADDED DESIGNATOR = 82 TASK FORMATS AT CONCEPTUAL LEVEL
*** TOTAL DESIGNATORS NOW SELECTED : 11

*** MAKE NEXT ACTION REQUEST
_FILE

*** MODIFIED COURSES DESIGNATORS HAVE BEEN SAVED

SEARCH DESIGNATOR EDITOR NOW TERMINATING

FIGURE III-22. EXAMPLE OF PROGRAM P2

CSS

08.50.01 RUIP3 PN123

PROJECT NAMED PN123 ALREADY EXISTS,
IS THIS CORRECT? (RESPOND YES OR QUIT)

YES

\$\$\$

RANGE-OF-EFFECTS (ROE) SEARCH PROGRAM IS STARTING

RANGE-OF-EFFECTS SEARCH FOR PROJECT : PN123
3-D PROCEDURAL TRAINER

*** NOW PROCESSING COURSES SEARCH - 11 DESCRIPTORS SELECTED

TOTAL NUMBER DESCRIPTOR RECORDS EXAMINED :	122
TOTAL RECORDS SELECTED WITH MATCHING DATA :	37
TOTAL RECORDS SELECTED WITHOUT ABBREVIATED DATA :	24
ACCUMULATED SEARCH OUTPUT RECORDS, THIS FAR :	61

*** NOW PROCESSING VEHICLES SEARCH - 1 DESCRIPTORS SELECTED

*** NO SEARCH DESCRIPTORS SPECIFIED FOR VEHICLES TYPE DATA - SEARCH IS BYPASSED

*** NOW PROCESSING TASKS SEARCH - 1 DESCRIPTORS SELECTED

*** NO SEARCH DESCRIPTORS SPECIFIED FOR TASKS TYPE DATA - SEARCH IS BYPASSED

*** DESIGNATOR SEARCH PROGRAM IS TERMINATING

TOTAL ACCUMULATED SEARCH OUTPUT RECORDS : 61

FIGURE III-23. EXAMPLE OF PROGRAM P3

TAEG REPORT NO. 40

CSS

00.51.59 RUMP5A PN123

PROJECT NAMED PN123 ALREADY EXISTS,
IS THIS CORRECT? (RESPOND YES OR QUIT)

YES

OUTPUT TO GO TO TERMINAL, OFFLINE PRINTER, BOTH, OR QUIT?
ENTER TERM, PRTR, BOTH, OR QUIT
BOTH

5EXECUTION:

*** INITIAL SEARCH RESULTS FOR PROJECT -PN123 ***
3-D PROCEDURAL TRAINER

PAGE NUMBER : 1

RANGE-OF-EFFECTS RESULTS FOR : COURSES

1 A1020000 NOTE - NO MATCHING NITRAS DATA AVAILABLE FOR THIS CIN
2 A1020093 NOTE - NO MATCHING NITRAS DATA AVAILABLE FOR THIS CIN
3 A1020095 NOTE - NO MATCHING NITRAS DATA AVAILABLE FOR THIS CIN
4 A1930050 2213 INERT NAV PRINC
5 A2420010 6529 IS A
6 A4120010 6078 EA-A
7 A4120010 6287 EA A
8 A4310011 1035 EOD BASIC NAVY
9 A4310014 1036 EOD REFR NAVY
10 A4330019 2040 MASTER DIVQUAL
11 A4330025 2002 DIVER FIRST
12 A4910014 2040 RADIUM REMOV OPS
13 A5510019 0133 CAR HAND BAS
14 A5510027 3931 UNREP MECH/HYD
15 A5510068 0134 FORK LIFT OPER
16 A5000016 6053 CTO A
17 A6510020 5399 1200 PSI BT
18 A6520050 5224 OX GENR GL100P
19 A6520068 463E SOLAR GAS TURBIN
20 A6700011 3078 WATCH REPAIR
21 A7010027 337M WELD/HPRES PIPE
22 A7200013 4662 UT-J
23 B3030051 NOTE - NO MATCHING NITRAS DATA AVAILABLE FOR THIS CIN
24 C 003722 2887 TA4JF FAM PILOTS
25 C 003722 9007 TA4JF FAM PILOTS
26 C 003722 9009 TA4JF FAM PILOTS

FIGURE III-24. EXAMPLE OF PROGRAM P5A

TAEG REPORT NO. 40

27 C 003722 9010 TA4JF FAM PILOTS
 28 C 003722 9738 TA4JF FAM PILOTS
 29 C 2C3352 2576 UH1N A/C FAM/P/
 30 C1003834 7529 AAS18 INT MAI
 31 C1023793 7914 A7AB ATT HEADING
 32 C1023793 7915 A7AB ATT HEADING
 33 C1213011 346L AWM23 RADIO FREQ
 34 C1213011 544L AWM23 RADIO FREQ
 35 C6003472 340C E2C WEA SYS FAM
 36 C6023536 341D 54H6077 PROP INT
 37 C6463103 7365 CVA/CV ALW SUPV
 38 D 2C0011 NOTE - NO MATCHING NITRAS DATA AVAILABLE FOR THIS CIN
 39 E 2A1001 NOTE - NO MATCHING NITRAS DATA AVAILABLE FOR THIS CIN
 40 E 2A1301 NOTE - NO MATCHING NITRAS DATA AVAILABLE FOR THIS CIN
 41 E 2A1803 NOTE - NO MATCHING NITRAS DATA AVAILABLE FOR THIS CIN
 42 E 2C0901 NOTE - NO MATCHING NITRAS DATA AVAILABLE FOR THIS CIN
 43 E 2D0016 NOTE - NO MATCHING NITRAS DATA AVAILABLE FOR THIS CIN
 44 E 2D0075 NOTE - NO MATCHING NITRAS DATA AVAILABLE FOR THIS CIN
 45 E6010210 NOTE - NO MATCHING NITRAS DATA AVAILABLE FOR THIS CIN
 46 E6461641 NOTE - NO MATCHING NITRAS DATA AVAILABLE FOR THIS CIN
 47 F7000010 NOTE - NO MATCHING NITRAS DATA AVAILABLE FOR THIS CIN
 48 H 2E3710 NOTE - NO MATCHING NITRAS DATA AVAILABLE FOR THIS CIN
 49 J1300645 NOTE - NO MATCHING NITRAS DATA AVAILABLE FOR THIS CIN
 50 J2210357 538Q MULTI-THREAT TNG
 51 J2330203 2637 ADV EW OP'S CRSE
 52 J2430974 2181 IPC
 53 J8000433 NOTE - NO MATCHING NITRAS DATA AVAILABLE FOR THIS CIN
 54 K2330066 205Y SUB EW OP-ADV
 55 L1010024 NOTE - NO MATCHING NITRAS DATA AVAILABLE FOR THIS CIN

PAGE NUMBER : 2

RANGE-OF-EFFECTS RESULTS FOR : COURSES

 56 L6610056 NOTE - NO MATCHING NITRAS DATA AVAILABLE FOR THIS CIN
 57 M198100E NOTE - NO MATCHING NITRAS DATA AVAILABLE FOR THIS CIN
 58 N7010320 NOTE - NO MATCHING NITRAS DATA AVAILABLE FOR THIS CIN
 59 Q 2C0015 NOTE - NO MATCHING NITRAS DATA AVAILABLE FOR THIS CIN
 60 83000010 NOTE - NO MATCHING NITRAS DATA AVAILABLE FOR THIS CIN
 61 83000012 NOTE - NO MATCHING NITRAS DATA AVAILABLE FOR THIS CIN

*** RESULTS FILE NOW AT END-OF-FILE ***

TOTAL NUMBER COURSE RECORDS PROCESSED : 61
 TOTAL NUMBER VEHICLE RECORDS PROCESSED : 0
 TOTAL NUMBER JOBTASK RECORDS PROCESSED : 0
 TOTAL NUMBER ROE RESULT RECORDS READ : 61
 RECORDS WITHOUT MATCHING ABBREVIATED DATA : 24
 TOTAL NUMBER DIRECTORY SEARCH FAILURES : 0

FIGURE III-24. EXAMPLE OF PROGRAM P5A (Cont'd)

Program P5B (Interactive Search Results Editor). Program P5B permits the user to edit the contents of the RESU file which contains the results of the search of the Abbreviated Data Bases for matching courses, vehicles, and job/tasks. Entities in the RESU file are referenced by the sequence number with which they were associated in the print out from Program P5B. If the list is short, the user can print the results of the search by entering PRINT n1 n2 where n1 is the sequence number of the first line to be printed, and n2 is the sequence number of the last line; e.g., PRINT 1 61 will print 61 lines. An entity can be deleted by entering DELETE n where n is the sequence number of the entity to be deleted. Multiple deletes may be made by entering DELETE n1 n2 which will cause all entities with sequence numbers from n1 through n2 inclusively to be deleted. An entity is added by entering ADDC /entity id/; e.g., ADDC /A101010108, for courses, ADDV /entity id/; e.g., ADDV /6910LLC003399/, for vehicles, and ADDJ /entity id/; e.g., ADDJ /BM/CM/35492/, for job/tasks. Figure III-25 shows an example of a run of Program P5B. The results of the editing are saved automatically when the user enters QUIT.

Program P5C (Print of ROE Search Results For Extract). Program P5C permits the user to print a list of entities for which additional data must be obtained prior to beginning the Assessment process. Only the original (non-deleted) and added entities will be listed by this program. Figure III-26 shows an example of the print out of Program P5C. Output can be directed to the terminal or offline printer, or both. The results of the extract print are retained in the REE file of the Project Data Base and can be listed using Program P1 (refer to Figure III-21 for an example of a Program P1 printout of the REE file containing the results of the extract print shown in Figure III-26).

ETAM COST MODELS. ETAM is capable of performing a quantitative assessment of the costs/savings which will result from introducing an innovation. The dollar effects are calculated by running the appropriate cost model with the input variables set at some baseline state, then rerunning the model with the particular variable modified so that it now reflects the value resulting from successful implementation of the innovation. Seven ETAM programs are involved in the performance of this function. Three are required to load the extract files (EXC, EXV, and EXJ) with model baseline input data. An interactive program permits the user to modify input variables based upon the quantitative characteristics of the benefit pattern resulting from successful implementation of the innovation. There are three model programs, i.e., training course, vehicles, and job/tasks. The objectives in performing the cost modeling function are:

1. Load extract files EXC, EXV, and EXJ with card input data returned from responsible Navy sources. This will essentially be a batch operation.
2. Provide interactive capability to review, modify baseline, and develop benefit related input variables for running the cost model programs.
3. Select and run the appropriate cost model program to calculate the delta effect of applying the innovation benefits to the entities identified (and possibly manually refined) during the ETAM Range-of-Effect function.
4. Store the calculated difference in the CMR file for subsequent use in the Decision Analysis and/or Financial Analysis routines.

TAEG REPORT NO. 40

CSS

00.58.56 RUNP5B PN123

PROJECT NAMED PN123 ALREADY EXISTS,
IS THIS CORRECT? (RESPOND YES OR QUIT)

YES
9999

*** ROL SEARCH RESULTS EDIT FOR PROJECT PN123 ***
3-D PROCEDURAL TRAINER

*** 61 HAVE BEEN LOADED INTO MEMORY FOR EDITING

*** MAKE NEXT ACTION REQUEST

_DELETE 1 3
DELETED RECORD NUMBER : 1 THRU 3

*** MAKE NEXT ACTION REQUEST

_DELETE 23
DELETED RECORD NUMBER : 23

*** MAKE NEXT ACTION REQUEST

_DELETE 38 49
DELETED RECORD NUMBER : 38 THRU 49

*** MAKE NEXT ACTION REQUEST

_DELETE 53
DELETED RECORD NUMBER : 53

*** MAKE NEXT ACTION REQUEST

_DELETE 55
DELETED RECORD NUMBER : 55

*** MAKE NEXT ACTION REQUEST

_ADD /A1010108/

THE FOLLOWING RECORD(S) HAS/HAVE BEEN ADDED...

RECNO/CIN/CDP/COURSE : 62/A10101087654/ WRA-4 CMB MA

*** MAKE NEXT ACTION REQUEST

_PRINT 1 61

RECNO/CIN/CDP/TITLE : 1/A1020060/ / (NO MATCHING DATA)

RECNO/CIN/CDP/TITLE : 2/A1020093/ / (NO MATCHING DATA)

RECNO/CIN/CDP/TITLE : 3/A1020095/ / (NO MATCHING DATA)

RECNO/CIN/CDP/TITLE : 4/A1930050/2213/ INERT NAV PRINC

RECNO/CIN/CDP/TITLE : 5/A2420010/6529/ IS A

RECNO/CIN/CDP/TITLE : 6/A4120010/6078/ EA-A

FIGURE III-25. EXAMPLE OF PROGRAM P5B

TAEG REPORT NO. 40

RECNO/CIN/CDP/TITLE : 7/A41200010/6287/ EA A
 RECNO/CIN/CDP/TITLE : 8/A43100011/1035/ EOD BASIC NAVY
 RECNO/CIN/CDP/TITLE : 9/A43100014/1036/ EOD REFR NAVY
 RECNO/CIN/CDP/TITLE : 10/A43300019/2040/ MASTER DIVOVAL
 RECNO/CIN/CDP/TITLE : 11/A43300025/2082/ DIVER FIPST
 RECNO/CIN/CDP/TITLE : 12/A49100014/2040/ RADIUM REMOV OPS
 RECNO/CIN/CDP/TITLE : 13/A55100019/0133/ CAR HAND BAS
 RECNO/CIN/CDP/TITLE : 14/A55100027/3031/ UNREP MECH/HYD
 RECNO/CIN/CDP/TITLE : 15/A55100068/0134/ FORK LIFT OPER
 RECNO/CIN/CDP/TITLE : 16/A58000016/6053/ CTO A
 RECNO/CIN/CDP/TITLE : 17/A65100020/5399/ 1200 PSI BT
 RECNO/CIN/CDP/TITLE : 18/A65200050/5224/ OX GENR 6L160P
 RECNO/CIN/CDP/TITLE : 19/A65200068/403E/ SOLAR GAS TURBIN
 RECNO/CIN/CDP/TITLE : 20/A67000011/3078/ WATCH REPAIR
 RECNO/CIN/CDP/TITLE : 21/A70000027/337M/ WELD/HPRES PIPE
 RECNO/CIN/CDP/TITLE : 22/A72000013/406Z/ UT-J
 RECNO/CIN/CDP/TITLE : 23/B30000051/ / (NO MATCHING DATA)
 RECNO/CIN/CDP/TITLE : 24/C 0003722/2887/ TA4JF FAM PILOTS
 RECNO/CIN/CDP/TITLE : 25/C 0003722/9007/ TA4JF FAM PILOTS
 RECNO/CIN/CDP/TITLE : 26/C 0003722/9009/ TA4JF FAM PILOTS
 RECNO/CIN/CDP/TITLE : 27/C 0003722/9010/ TA4JF FAM PILOTS
 RECNO/CIN/CDP/TITLE : 28/C 0003722/9738/ TA4JF FAM PILOTS
 RECNO/CIN/CDP/TITLE : 29/C 203352/2576/ UH1N A/C FAM/P/
 RECNO/CIN/CDP/TITLE : 30/C10003834/7529/ AAS18 INT MAI
 RECNO/CIN/CDP/TITLE : 31/C1023793/7914/ A7AB ATT HEADING
 RECNO/CIN/CDP/TITLE : 32/C1023793/7915/ A7AB ATT HEADING
 RECNO/CIN/CDP/TITLE : 33/C1213011/346L/ AWM23 RADIO FREQ
 RECNO/CIN/CDP/TITLE : 34/C1213011/544L/ AWM23 RADIO FREQ
 RECNO/CIN/CDP/TITLE : 35/C60003472/340C/ E2C WEA SYS FAM

FIGURE III-25. EXAMPLE OF PROGRAM P5B (Cont'd)

TAEQ REPORT NO. 40

RECNO/CIN/CDP/TITLE : 36/C6823536/341D/ 54H6877 PROP INT
 RECNO/CIN/CDP/TITLE : 37/C6463183/7365/ CVA/CV ALV SUPV
 RECNO/CIN/CDP/TITLE : 38/D 2C8811/ / (NO MATCHING DATA)
 RECNO/CIN/CDP/TITLE : 39/E 2A1881/ / (NO MATCHING DATA)
 RECNO/CIN/CDP/TITLE : 48/E 2A1381/ / (NO MATCHING DATA)
 RECNO/CIN/CDP/TITLE : 41/E 2A1883/ / (NO MATCHING DATA)
 RECNO/CIN/CDP/TITLE : 42/E 2C8981/ / (NO MATCHING DATA)
 RECNO/CIN/CDP/TITLE : 43/E 2D8816/ / (NO MATCHING DATA)
 RECNO/CIN/CDP/TITLE : 44/E 2D8875/ / (NO MATCHING DATA)
 RECNO/CIN/CDP/TITLE : 45/E6818218/ / (NO MATCHING DATA)
 RECNO/CIN/CDP/TITLE : 46/E6461641/ / (NO MATCHING DATA)
 RECNO/CIN/CDP/TITLE : 47/F7888818/ / (NO MATCHING DATA)
 RECNO/CIN/CDP/TITLE : 48/H 2E3718/ / (NO MATCHING DATA)
 RECNO/CIN/CDP/TITLE : 49/J1388645/ / (NO MATCHING DATA)
 RECNO/CIN/CDP/TITLE : 58/J2218357/538Q/ MULTI-THREAT TNG
 RECNO/CIN/CDP/TITLE : 51/J2338283/2637/ ADV EW OP'S CRSE
 RECNO/CIN/CDP/TITLE : 52/J2438974/2181/ IPC
 RECNO/CIN/CDP/TITLE : 53/J8888433/ / (NO MATCHING DATA)
 RECNO/CIN/CDP/TITLE : 54/K2338866/285Y/ SUB EW OP-ADV
 RECNO/CIN/CDP/TITLE : 55/L1818824/ / (NO MATCHING DATA)
 RECNO/CIN/CDP/TITLE : 56/L6618856/ / (NO MATCHING DATA)
 RECNO/CIN/CDP/TITLE : 57/M198188E/ / (NO MATCHING DATA)
 RECNO/CIN/CDP/TITLE : 58/N7818328/ / (NO MATCHING DATA)
 RECNO/CIN/CDP/TITLE : 59/Q 2C8815/ / (NO MATCHING DATA)
 RECNO/CIN/CDP/TITLE : 68/83888818/ / (NO MATCHING DATA)
 RECNO/CIN/CDP/TITLE : 61/83888812/ / (NO MATCHING DATA)

*** MAKE NEXT ACTION REQUEST
 _QUIT

*** ROE SEARCH RESULTS EDITOR IS TERMINATING

TOTAL RECORDS ADDED : 1

TOTAL RECORDS IN PROJECT EXTRACT FILE : 44

FIGURE III-25. EXAMPLE OF PROGRAM P5B (Cont'd)

TAEG REPORT NO. 40

CSS

09.13.50 RUNP5C PN123

PROJECT NAMED PN123 ALREADY EXISTS,
IS THIS CORRECT? (RESPOND YES OR QUIT)

YES

OUTPUT TO GO TO TERMINAL, OFFLINE PRINTER, BOTH, OR QUIT?
ENTER TERM, PRTR, BOTH, OR QUIT
BOTH

\$\$\$ 0 PN123

KEYWORD OR ARGUMENT ERROR
EXECUTION:

*** EXTRACT SEARCH RESULTS FOR PROJECT - PN123 ***
3-D PROCEDURAL TRAINER

PAGE NUMBER : 1

1	ORIGINAL	A1930050	2213	INERT NAV PRINC
2	ORIGINAL	A2420010	6529	IS A
3	ORIGINAL	A4120010	6078	EA-A
4	ORIGINAL	A4120010	6287	EA A
5	ORIGINAL	A4310011	1035	EOD BASIC NAVY
6	ORIGINAL	A4310014	1036	EOD REFR NAVY
7	ORIGINAL	A4330019	2040	MASTER DIVOVAL
8	ORIGINAL	A4330025	2082	DIVER FIRST
9	ORIGINAL	A4910014	2046	RADIUM REMOV OPS
10	ORIGINAL	A5510019	0133	CAR HAND BAS
11	ORIGINAL	A5510027	3931	UNREP MECH/HYD
12	ORIGINAL	A5510068	0134	FORK LIFT OPER
13	ORIGINAL	A5800016	6053	CTO A
14	ORIGINAL	A6510020	5390	1200 PSI BT
15	ORIGINAL	A6520050	5224	OX GENR 6L160P
16	ORIGINAL	A6520068	463E	SOLAR GAS TURBIN
17	ORIGINAL	A6700011	3078	WATCH REPAIR
18	ORIGINAL	A7010027	337M	WELD/HPRES PIPE
19	ORIGINAL	A7200013	466Z	UT-J

FIGURE III-26. EXAMPLE OF PROGRAM P5C

AD-A041 217

IBM CORP CAPE CANAVERAL FLA
DESIGN OF TRAINING SYSTEMS. COMPUTERIZATION OF THE EDUCATIONAL --ETC(U)
MAY 77 L R DUFFY, R B MILLER, J D STALEY
TAEG-40-VOL-1

F/G 5/1

N61339-73-C-0097

NL

UNCLASSIFIED

2 OF 3

AD
A041217



TAEG REPORT NO. 40

20	ORIGINAL	C 003722	2887	TA4JF FAM PILOTS
21	ORIGINAL	C 003722	9007	TA4JF FAM PILOTS
22	ORIGINAL	C 003722	9009	TA4JF FAM PILOTS
23	ORIGINAL	C 003722	9010	TA4JF FAM PILOTS
24	ORIGINAL	C 003722	9738	TA4JF FAM PILOTS
25	ORIGINAL	C 2C3352	2576	UH1N A/C FAM/P/
26	ORIGINAL	C1003834	7529	AAS18 INT MAI
27	ORIGINAL	C1023793	7914	A7AB ATT HEADING
28	ORIGINAL	C1023793	7915	A7AB ATT HEADING
29	ORIGINAL	C1213011	346L	AWM23 RADIO FREQ
30	ORIGINAL	C1213011	544L	AWM23 RADIO FREQ
31	ORIGINAL	C6003472	340C	E2C WEA SYS FAM
32	ORIGINAL	C6023536	341D	54H6077 PROP INT
33	ORIGINAL	C6463103	7365	CVA/CV-ALW SUPV
34	ORIGINAL	J2210357	538Q	MULTI-THREAT TNG
35	ORIGINAL	J2330203	2637	ADV EW OP'S CRSE
36	ORIGINAL	J2430974	2181	IPC
37	ORIGINAL	K2330066	205Y	SUB EW OP-ADV
38	ORIGINAL	L6610056	NONE	(NO ABBREVIATED FILE DATA AVAILABLE)
39	ORIGINAL	M198100E	NONE	(NO ABBREVIATED FILE DATA AVAILABLE)
40	ORIGINAL	N7010320	NONE	(NO ABBREVIATED FILE DATA AVAILABLE)
41	ORIGINAL	Q 2C0015	NONE	(NO ABBREVIATED FILE DATA AVAILABLE)
42	ORIGINAL	83000010	NONE	(NO ABBREVIATED FILE DATA AVAILABLE)
43	ORIGINAL	83000012	NONE	(NO ABBREVIATED FILE DATA AVAILABLE)
44	ADDED	A1010100	7654	WRA-4 CMB MA

*** NOW AT EOF ON SEARCH RESULTS FILE ***

TOTAL NUMBER COURSE RECORDS PROCESSED :	44
TOTAL NUMBER VEHICLE RECORDS PROCESSED :	0
TOTAL NUMBER JOBTASK RECORDS PROCESSED :	0
TOTAL NUMBER ROE RESULT RECORDS READ :	44
RECORDS WITHOUT MATCHING ABBREVIATED DATA :	7
TOTAL NUMBER DIRECTORY SEARCH FAILURES :	0

FIGURE III-26. EXAMPLE OF PROGRAM P5C (Cont'd)

These objectives are accomplished through seven programs, namely:

- P10 - Course Extract Data Base Load
- P11 - Vehicle Extract Data Base Load
- P12 - Job/Task Extract Data Base Load
- P51 - Interactive Benefit Pattern Setup
- P52 - Training Course Cost Model
- P53 - Vehicles Cost Model
- P54 - Job Task Cost Model

These programs are supported by four Project Data Base files: EXC, EXV, and EXJ which store the extract input data, CMR which stores the models' output data, and two temporary files which are set up with the baseline state and the benefit state of the cost models' input variables.

The programs and data files to support the ETAM Cost Model part of the ETAM Assessment function are outlined in this section. Figure III-27 shows the interrelationships between the Programs P51 through P54 and Executive Control.

Program P10 (Course Extract Data Base Load).

Purpose: This program loads the EXC file from cards which contain the additional data on Courses required for the ETAM Assessment function.

Inputs: Refer to Figure III-6 EXC DATA ELEMENTS for a list of the input variables, their record length, and format. The input cards will be formatted as follows:

<u>CARD NO.</u>	<u>VARIABLE FROM/THROUGH</u>	<u>REC POS</u>	<u>CARD COLS</u>
1	CDP . . . PESP	1-79	1-79
2	TLEGTH . . . DRATE	80-157	1-78
3	INRATE . . . GRAD(11)	158-234	1-77
4	GRAD (12) . . . COPMT(5)	235-313	1-79
5	COPMT(6) . . . COPMT(20)	314-388	1-75

Missing data should be unpunched (not zeros). Cards will be sequence numbered 1-5 in Col. 80.

Process: The major program process steps are:

1. Read input cards.
2. Check sequence numbers for order and for missing cards. If the variable N (Planning Period (Years)) is 5 or less, then Card No. 5 is not required, (although this is optional) since no data would exist for COPMT(6) through COPMT(20).
3. Print appropriate error messages.
4. List data formatted with variable headings for readability by the user. Provide the list option for terminal or offline printer, or both.
5. Identify missing data (unpunched) in the listing with an asterisk (*).
6. Create single 388 position record to be written in the EXC file.
7. Compare returned data with Entity Type 1 records in the REE file for matching CDP's.
8. Print list of unmatched CDP's in either file. This list should be directed to the terminal.

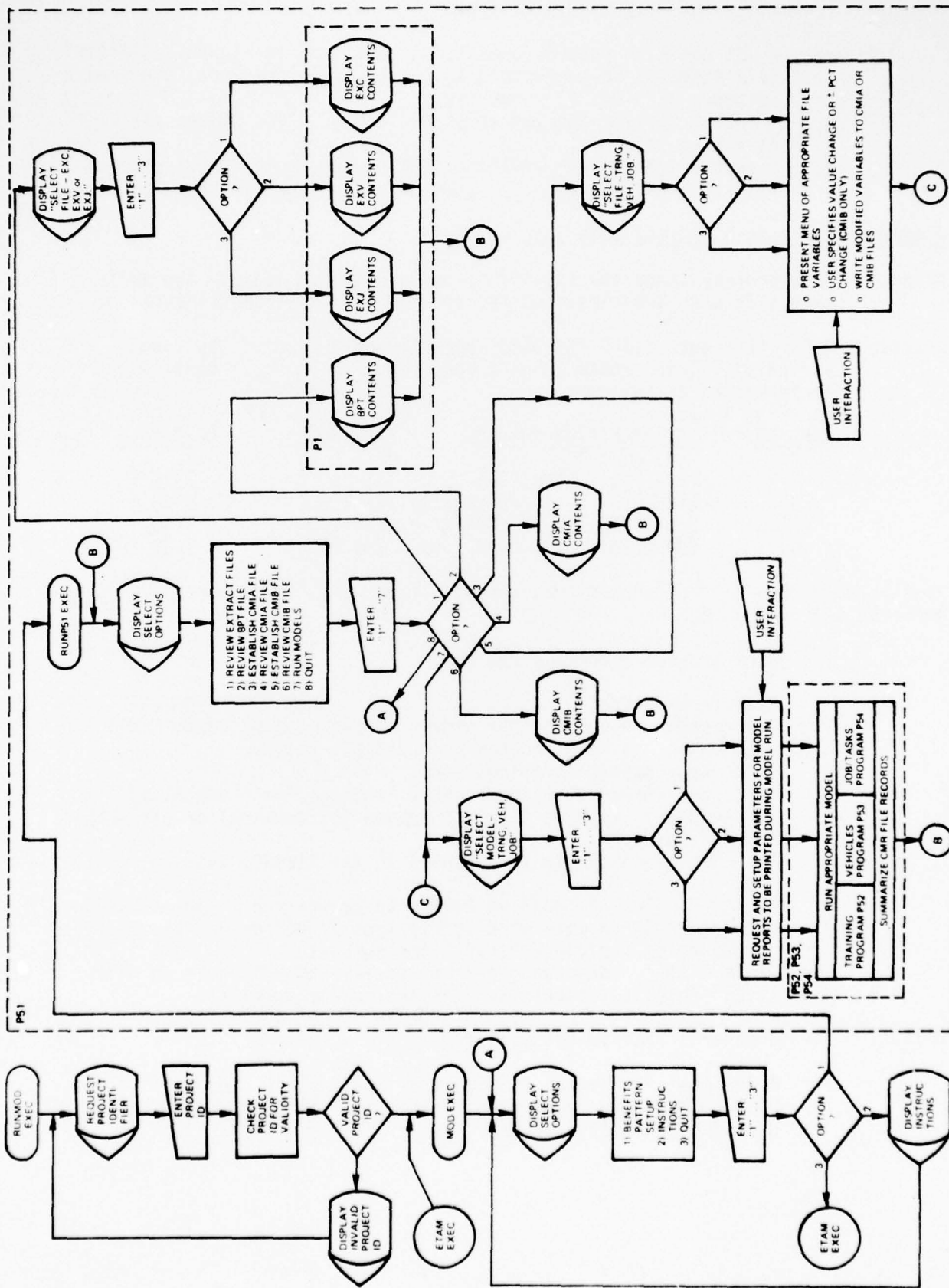

FIGURE III-27. ETAM, COST MODELS (MOD) PROCESS FLOW

TAEG REPORT NO. 40

Output: The outputs of Program P10 will be:

1. A 388 position record formatted as outlined in Figure III-6 EXC DATA ELEMENTS to be written to the EXC file (one record per each sequence of 5 (or 4) input cards).
2. A report listing the variables for each CDP for which data have been provided.
3. A report identifying unmatched CDP's with the original extract listing from Program P5C, (these are contained in the REE file).

Program P11 (Vehicle Extract Data Base Load).

Purpose: This program loads the EXV file from cards which contain the additional data on Vehicles required for the ETAM Assessment function.

Inputs: Refer to Figure III-7 EXV DATA ELEMENTS for a list of the input variables, their record length, and format. The input cards will be formatted as follows:

<u>CARD NO.</u>	<u>VARIABLE FROM/THROUGH</u>	<u>REC POS</u>	<u>CARD COLS</u>
1	VFSN . . . PEQUIP(6)	1-76	1-76
2	PEQUIP(7) . . . PEQUIP(19)	77-154	1-78
3	PEQUIP(20) . . . COPMT(14)	155-230	1-76
4	COPMT(15) . . . COPMT(20)	231-260	1-30

Missing data should be unpunched (not zeros). Cards will be sequence numbered 1-4 in Col. 80.

Process: The major program process steps are:

1. Read input cards.
2. Check sequence numbers for order and for missing cards. All four cards are required for each Vehicle Entity.
3. Print appropriate error messages.
4. List data formatted with variable headings for readability by the user. Provide the list option for terminal or offline printer, or both.
5. Identify missing data (unpunched) in the listing with an asterisk (*).
6. Create single 260 position record to be written in the EXV file.
7. Compare returned data with Entity Type 2 records in the REE file for matching Vehicle Federal Stock Numbers.
8. Print list of unmatched Vehicle Federal Stock Numbers in either file. This list should be directed to the terminal.

Output: The outputs of Program P11 will be:

1. A 260 position record formatted as outlined in Figure III-7 EXV DATA ELEMENTS to be written to the EXV file (one record per each sequence of 4 input cards).

TAEG REPORT NO. 40

2. A report listing the variables for each Vehicle Federal Stock Number for which data have been provided.
3. A report identifying unmatched Vehicle Federal Stock Numbers with the original extract listing from Program P5C, (these are contained in the REE file.).

Program P12 (Job/Task Extract Data Base Load).

Purpose: This program loads the EXJ file from cards which contain the additional data on Job/Tasks required for the ETAM Assessment function.

Inputs: Refer to Figure III-8 EXJ DATA ELEMENTS for a list of the input variables, their record length, and format. The input cards will be formatted as follows:

<u>CARD NO.</u>	<u>VARIABLE FROM/THROUGH</u>	<u>REC POS</u>	<u>CARD COLS</u>
1	JTID . . . INRATE	1-77	1-77
2	APERS(1) . . . APERS(13)	78-155	1-78
3	APERS(14) . . . APERS(20)	156-197	1-42

Missing data should be unpunched (not zeros). Cards will be sequence numbered 1-3 in Col. 80.

Process: The major program process steps are:

1. Read input cards.
2. Check sequence numbers for order and for missing cards. If the variable N (Planning Period (Years)) is 13 or less, then Card No. 3 is not required, (although this is optional) since no data would exist for APERS(14) through APERS(20).
3. Print appropriate error messages.
4. List data formatted with variable headings for readability by the user. Provide the list option for terminal or offline printer, or both.
5. Identify missing data (unpunched) in the listing with an asterisk (*).
6. Create single 197 position record to be written in the EXJ file.
7. Compare returned data with Entity Type 3 records in the REE file for matching Job/Task Identifiers.
8. Print list of unmatched Job/Task Identifiers in either file. This list should be directed to the terminal.

Output: The outputs of Program P12 will be:

1. A 197 position record formatted as outlined in Figure III-8 EXJ DATA ELEMENTS to be written to the EXJ file (one record per each sequence of 3 (or 2) input cards.
2. A report listing the variables for each Job/Task Identifier for which data have been provided.
3. A report identifying unmatched Job/Task Identifiers with the original extract listing from Program P5C, (these are contained in the REE file).

Program P51 (Interactive Benefit Pattern Setup).

Purpose: The objective of Program P51 is to establish interactively the pattern of benefits which will be accruing from the innovation reflected in a modification of the variables which are inputs to the three cost models. The baseline values for the cost models input variables are stored in the Project Data Base files EXC, EXV, and EXJ. In general, these values can be used directly and moved to the CMIA file for input to the baseline (first pass) run of the cost model's processing sequence. However, the user has the option of modifying any of the variables stored in the three extract files prior to moving them to the CMIA file. The user then is permitted to apply the benefit pattern as reflected descriptively in the Project Data Base file BPT to the input variables prior to moving them to the CMIB file. The benefit pattern is established for any one or combination of input variables by indicating a new value for that variable or some percentage change to be applied to that variable.

Inputs: The inputs to Program P51 are the contents of the EXC, EXV, and EXJ files, which were previously shown in Figures III-6, 7 and 8. The user provides control input via the terminal by selecting one of the available options provided by Program P51.

Process: Following are the major process steps for Program P51:

1. The user accesses this program by entering RUNP51 EXEC or by the select option within the ETAM EXEC called MOD.
2. The user is then presented with a display menu of the various options that he can select at this time. This menu will be as follows:
 - o Review extract files
Under this option the user will be allowed to review the contents of any of the extract files EXC, EXV, or EXJ.
 - o Review BPT file
Normally the user would refer to a listing of the Project Data Base previously printed from Program P1. However, if the user wishes to scan the BPT file at this time, he will have access to it through this select option.
 - o Establish CMIA file
Here the user will be allowed to either transfer the contents of the extract files directly to CMIA or permitted to make modifications if new data exists at this time. The modification of extract data going to the CMIA file will generally be on a straight value change basis rather than a percentage change as will be possible under the benefit modification of data going to the CMIB file.
 - o Review/print the CMIA file
The user will be allowed to print the contents of the CMIA file under this select option.
 - o Establish CMIB file
The CMIB file will contain the variables as modified to reflect the benefit pattern accruing from the innovation. At this point the user will select the specific variable or variables from the display of the EXC, EXV, or EXJ files and make the appropriate modification, either by a value change

or by indicating a percentage change from its baseline value. The result of this modification after all variables have been treated, will be moved to the CMIB file as input to the second pass of the Cost Model runs.

- o Review CMIB file
Under this option the user will have two possible selections. First, the CMIB file can be reviewed as was done with the CMIA file. Second, the user can request only those variables which differ from the CMIA file to be printed. Under this option both the original value in the CMIA file and the new value in the CMIB file will be printed.
- o Run Cost Model
Any one or all of the Cost Models can be selected to run against the input variables in the CMIA and CMIB files at this time. Appropriate error messages will be indicated if the CMIA and CMIB files have not previously been set up. Also, as a part of this selection step, the user can select any of the report options available with each of the cost models. For example, under the training cost model, seven report outputs are selectable. The user specifies which of these reports are desired to be printed and also, the user will direct the output to either the terminal or the offline printer, or both.
- o Quit
Under this option the user returns to the next higher level of EXEC, which in this case would permit the selection of another option under Assessment.

3. Following completion of any one of the options selected under Step 2, the user will be returned to the display permitting another option to be selected.

Outputs: The major outputs from the benefit pattern setup program are:

1. A series of display prompts which let the user select, via the terminal, the various options under this program.
2. A variety of reports which display the results of selecting any one of the options identified under Step 2. For example, if a review of the BPT file is selected, an appropriate report will be printed. In this case, the report would be the same as that generated under Program P1. All reports generated from this program will be formatted with appropriate headings for user readability. The user will also have the option of selecting either the terminal or offline printer, or both.
3. Although not a direct output of Program P51, selection of the Cost Models to be run will cause certain reports to be generated from the respective Cost Model programs. The selection of these reports is under the control of Program P51; i.e., Program P51 sets up the run parameters for the Cost Models identifying the reports to be printed.

Program P52 (Training Cost Model).

Purpose: The primary objective of ETAM is to evaluate the effects of an innovation which has been implemented within the training system. In order to perform this function, a model capable of calculating training costs

under different input assumptions was required. A model had been developed for TECEP (Training Effectiveness, Cost Effectiveness Prediction)* technique which had most of the features required for performing the training calculations. The basic logic of the program has been incorporated into the Training Cost Model outlined here. A program listing has been included in Appendix C of this report. Several features which were added to the original program are:

- 1) Extensive input data editing and default data specification.
- 2) User selectable policies for equipment purchases and equipment depreciation.
- 3) Selectable output reports.
- 4) Output format design is compatible with 80X24 CRT displays to facilitate any conversion from the present thermal printer to a CRT display capability.

Extensive commenting within the program was done to guide the programmer in the final incorporation of the Training Cost Module into the ETAM Training Cost Model. The model has been programmed to sequence through the calculations twice, once to compute the baseline technical and cost factors and another time to compute these factors with the benefits pattern developed in Program P51 applied. The program output intended for the CMR file is two twenty year vectors providing annual investment costs and annual recurring cost/savings. Examples of the model outputs are shown later in this section.

Input: The data input variables required to run the Training Cost Model were set up by Program P51. The baseline input variables are contained in the Cost Model's inputs W/O Benefits (CMIA) file and would generally reflect the EXC file unless modified by Program P51. The input variables with benefits applied as set up by Program P51 are contained in the Cost Model's input With Benefits (CMIB) file.

The input variables are the same as described in Figure III-6, EXC DATA ELEMENTS. Since the program design with the descriptions of input variables is explained in the previously referenced report on TECEP, only the input variables which have been modified from the original model are explained here.

- 1) **Equipment Purchase Policies (PURCHF)**
The Training Cost Model permits the user to specify any one of four purchase policies with regards to the equipment calculations within the Training Cost Model.

Policy 1 (Input Variable PURCHF = 1) causes the total average requirements for equipment to be purchased in the first year of the equipment life. Under this purchase option a buildup of training in which lesser equipment requirements exist in the earlier years would not be taken into consideration.

* Braby, Richard, Ed.D; Henry, James M.; Parrish, William F., Jr.; Swope, William M., Ph.D., 1975. A Technique for Choosing Cost-Effective Instructional Delivery Systems. TAEg Report No. 16, Training Analysis and Evaluation Group, Orlando, FL.

Policy 2 (input variable PURCHF = 2) causes the total maximum requirement for equipment over the equipment life to be purchased in the first year. This is similar to Policy 1, however, in Policy 2 the maximum requirement rather than the average requirement for equipment is purchased.

Policy 3 (input variable PURCHF = 3) causes equipment to be purchased up to the average requirement but with each purchase the requirement within the specific year of purchase is not exceeded. This policy provides a more efficient expenditure of resources for equipment in relationship to a buildup of training loads over the planning period.

Policy 4 (input variable PURCHF = 4) causes equipment to be purchased up to the maximum requirement over the equipment life but not to exceed the requirements in the specific year of purchase. This policy is similar to Policy 3, however, the maximum rather than average numbers of equipment are purchased.

2. Depreciation Policies (DEPF)

Policy 1 (input variable DEPF = 1) causes equipment to be depreciated linearly over its life.

Policy 2 (input variable DEPF = 2) causes a sum of the digits depreciation to take place over the equipment life.

Policy 3 (input variable DEPF = 3) causes the equipment to be fully depreciated over its life. Equipment purchased under this policy would have no remaining value at the end of the planning period.

3. Percent of Maximum Equipment Purchased (PCTPCH)

The user can specify the percent of calculated equipment requirements which are to be purchased under the specific purchase policy selected. This, in effect, permits the maximum requirement for equipment calculated by the model to be limited.

4. Inflation Rate (INRATE)

The user can have cost calculations made in four modes using the training cost model. The first is a non-discounted cost per year, the second is a discounted cost per year based upon the discount rate specified, the third is an inflated, non-discounted cost per year calculation which gives costs in current dollars, and fourth is the stream of costs, previously inflated, discounted at the discount rate specified.

Process: The major program process steps, within the Training Cost Model are:

1. Setup model to sequence through calculations using input from the CMIA file.

TAEG REPORT NO. 40

2. Read input variables from first Entity Type 1 (courses) record.
3. Calculate:

o Technical Processing Logic

INPUT	LOGIC	DESCRIPTION	OUTPUT
GRAD(I) ARATE	$STUD(I) = GRAD(I)/(1.0-ARATE)$	Input graduates required annually. Calculate student input reqmts. from annual graduates required and attrition rate.	STUD(I)
N	$AASIN = \frac{\sum_{I=1}^N STUD(I)}{N}$	Summarize average number of student inputs required over planning period N.	AASIN
TLENGH	$STUDMW(I) = (TLENGH*STUD(I))*(1.0-.5*ARATE)$	Calculate student manweeks from normal flow through course including attrites.	STUDMW(I)
RCRATE ARCYTM	$SMWRRC(I) = RCRATE*STUD(I)*ARCYTM$	Calculate student manweeks from set-back students recycled.	
WSCHOP	$AOB(I) = (STUDMW(I)+SMWRRC(I))/WSCHOP$	Calculate average-on-board from student manweeks distributed across school operating period.	AOB(I)
	$AAOB = \frac{\sum_{I=1}^N AOB(I)}{N}$	Summarize the average average-on-board over planning period N.	AAOB
TSPOSD WSHOP1	$PSP(I) = ((AOB(I)/1.0-TSPOSD))*(1.0+PESP) / (WSCHOP/WSHOP1)$	Calculate annual student position requirements considering average unavailability and a percentage extra positions for queuing.	PSP(I)
INTSPO	$RINSTR(I) = PSP(I)*INTSPO$	Calculate annual instructor reqmts using an instructor to student position ratio.	RINSTR(I)
AMTSPO	$RADMIN(I) = PSP(I)*AMTSPO$	Calculate annual administrative requirements using an admin. to student position ratio.	RADMIN(I)
EQTSP0	$REQUIP(I) = PSP(I)*EQTSP0$	Calculate annual equipment reqmts using an equip. to student position ratio.	REQUIP(I)
PURCHF LOFEQ	$PEQUIP(I) = f[PURCHF](REQUIP(I),LOFEQ)$	Calculate actual numbers of equipment purchased annually based on selected purchase policy and equipment life.	PEQUIP(I)
	$AEQUIP(J) = \sum_{I=N}^1 \sum_{J=LOFEQ+1}^J PEQUIP(I)$	Calculate available equipment on board annually over the planning period.	AEQUIP(I)
SOFTST SOFTIN SOFTAM	$RFACIL(I) = PSP(I)*(SOFTST+INTSPO*SOFTIN+AMTSPO*SOFTAM)$	Calculate annual facility requirements from Sq. Ft. ratios for students, instructors and administrators.	RFACIL(I)
IMDEV PUIMD TLEGTH	$UIMDTM = TLENGH*IMDEV*PUIMD*TLEGTH$	Calculate development time for instr. materials from dev. ratio and pct. of course length dev. mod.	UIMDTM
UPDATE	$IMDMNT(I) = UIMDTM*UPDATE$	Calculate annual maintenance time for instr. materials from maint. update ratio.	IMDMNT(I)
SUPSP0 SUPST0	$RSUPPL(I) = PSP(I)*SUPSP0+STUD(I)*SUPST0$	Calculate annual supply reqmts for student positions and students.	RSUPPL(I)
MSCSP0 MSCSTD	$RMISC(I) = PSP(I)*MSCSP0+STUD(I)*MSCSTD$	Calculate annual miscellaneous reqmts for student positions and student.	RMISC(I)

TAEG REPORT NO. 40

o Cost Processing Logic

INPUT	LOGIC	DESCRIPTION	OUTPUT
STUDSL	$CSTUD(I) = ((STUDM(I) + SMWRRC(I)) / 52) * STUDSL$	Calculate annual student salary costs in constant dollars.	CSTUD(I)
STCST1 STCST2	$CTRAV(I) = STUD(I) * (STCST1 + STCST2 * (1.0 - .5 * ARATE))$	Calculate annual student travel costs in constant dollars.	CTRAV(I)
INSTSL	$CINSTR(I) = RINSTR(I) * INSTSL$	Calculate annual instructor costs in constant dollars.	CINSTR(I)
ADMSL	$CADMIN(I) = RADMIN(I) * ADMSL$	Calculate annual administrative personnel costs in constant dollars.	CADMIN(I)
EQUINTC	$CEQUIP(I) = PEQUIP(I) * EQUINTC$	Calculate annual equipment purchase costs.	CEQUIP(I)
DEPF	$PDEP(L) = f[DEPF](LOFEQ)$	Calculate multiplier of original equipment cost indicating pct. of depreciation in year L of life.	PDEP(I)
PDEP(I)	$RVEQ = \sum_{I=1}^N CEQUIP(I) * (PDEP(I + LOFEQ - N - 1))$ for $(I + LOFEQ - N) > 0$	Calculate the remaining value of equipment at end of planning period.	RVEQ
COPMT(I)	$TAEOC(I) = CEQUIP(I) + AEQUIP(J) * COPMT(I)$	Calculate the total annual equipment purchase and maintenance cost.	TAEOC(I)
CPSQFT	$CFACIL(I) = RFACIL(I) * CPSQFT$	Calculate annual facilities cost in constant dollars.	CFACIL(I)
CIMD	$CIMDMT(I) = IMDMNT(I) * CIMD$ $CUIMD = UIMDMT * CIMD$	Calculate annual cost of maintaining developed course materials Calculate initial investment in instructional materials development	CIMDMT(I) CUIMD
EVIM	$RVIM = CUIMD * EVIM$	Calculate the remaining value of instructional materials at end of planning period.	RVIM
CSUPP	$CSUPPL(I) = RSUPPL(I) * CSUPP$	Calculate annual cost of supplies in constant dollars.	CSUPPL(I)
CMIS	$CMISCI(I) = RMISCI(I) * CMIS$	Calculate annual cost of miscellaneous in constant dollars.	CMISCI(I)
FACST LOFFA	$RFVA = (LOFFA - N) * (FACST / LOFFA)$	Calculate the remaining value of facilities at the end of the planning period.	RFVA

o Summarization and Financial Factors

INPUT	LOGIC	DESCRIPTION	OUTPUT
DRATE	$DISCNT(I) = (2.0 + DRATE) / (2.0 * (1.0 + DRATE) ** I)$	Calculate annual discount factors.	DISCNT(I)
INRATE	$INFCAT(I) = (2.0 * (1.0 + INRATE) ** I) / (2.0 + INRATE)$	Calculate annual inflation.	INFCAT(I)
	$NSTUD = \sum_{I=1}^N CSTUD(I)$		NSTUD
	also $NTRAV = f(CTRAV(I)), NINSTR = f(CINSTR(I)),$ $NSUPPL = f(CADMIN(I)),$ $NMISC = f(CMISCI(I))$	Calculate non-discounted total of annual student salary, travel, instructor salary, admin. salary, supply and miscellaneous costs.	NTRAV NINSTR NADMIN NMISC
	$NFACIL = (\sum_{I=1}^N CFACIL(I)) + FACOST$	Calculate non-discounted total of annual facilities costs.	NFACIL NSUPPL NMISC
	$NEQUIP = (\sum_{I=1}^N TAEOC(I)) - RVEQ$	Calculate non-discounted total of annual equipment and instr. mat. costs	NEQUIP
	$NIMD = (\sum_{I=1}^N CIMDMT(I)) * CUIMD - RVIM$		NIMD
	$DSTUD = \sum_{I=1}^N CSTUD(I) * DISCNT(I)$		DSTUD
	also $DTRAV = q(CTRAV(I)), DINSTR = q(CINSTR(I)),$ $DADMIN = q(CADMIN(I)),$ $DSUPPL = q(CSUPPL(I)), DMISC = q(CMISCI(I))$	Calculate discounted total of annual student salary, travel, instructor salary, admin. salary, supply and miscellaneous costs.	DSTUD DTRAV DINSTR DADMIN
	$DFACIL = (\sum_{I=1}^N CFACIL(I) * DISCNT(I)) + FACOST$	Calculate discounted total of annual facilities costs.	DFACIL DSUPPL DMISC
	$DEQUIP = (\sum_{I=1}^N TAEOC(I) * DISCNT(I)) - (RVEQ / (1.0 + DRATE) ** N)$	Calculate discounted total of annual equipment and instructor material costs.	DEQUIP
	$DIMD = (\sum_{I=1}^N CIMDMT(I) * DISCNT(I)) * CUIMD - (RVIM / (1.0 + DRATE) ** N)$		DIMD

TAEG REPORT NO. 40

INPUT	LOGIC	DESCRIPTION	OUTPUT
	$ISTUD = \sum_{I=1}^N CSTUD(I) * INFLAT(I)$		
	also $ITRAV = h(CTRAV(I), INSTR * h(CINSTR(I), ADMIN * h(CADMIN(I), ISUPPL * h(CSUPPL(I), IMISC * h(CMISC(I))$	Calculate inflated (current dollars) total of annual student salary, travel, instructor salary, admin. salary, supply and miscellaneous costs.	ISTUD ITRAV IINSTR IADMIN
	$IFACIL = \sum_{I=1}^N CFACIL(I) * INFLAT(I) + FACOST$	Calculated inflated (current dollars) total of annual facilities costs.	IFACIL ISUPPL IMISC
	$IEQUIP = \sum_{I=1}^N TAEQC(I) * INFLAT(I) - (RVEQ * (1.0 + INRATE)^N)$	Calculate inflated total of annual equipment and instructor mat. costs.	IEQUIP IIMD
	$IIMD = \sum_{I=1}^N CIMDMT(I) * INFLAT(I) - (RVIM * (1.0 + INRATE)^N)$		
	$FSTUD = \sum_{I=1}^N CSTUD(I) * INFLAT(I) * DISCNT(I)$		
	also $FTRAV = f(CTRAV(I), INSTR * f(CINSTR(I), FADMIN = f(CADMIN(I), FSUPPL = f(CSUPPL(I), FMISC = f(CMISC(I))$	Calculate discounted total of inflated annual student salary, travel, instructor salary, admin. salary, supply and miscellaneous costs.	FSTUD FTRAV FINSTR FADMIN
	$FFACIL = \sum_{I=1}^N CFACIL(I) * INFLAT(I) * DISCNT(I) + FACOST$	Calculate discounted total of inflated annual facilities costs.	FFACIL FSUPPL FMISC
	$FEQUIP = \sum_{I=1}^N TAEQC(I) * INFLAT(I) * DISCNT(I) - (RVEQ * (1.0 + INRATE - DRATE)^N)$	Calculated discounted total of annual equipment and instructor mat. costs.	FEQUIP FIMD
	$FIMD = \sum_{I=1}^N CIMDMT(I) * INFLAT(I) * DISCNT(I) - (RVIM * (1.0 + INRATE - DRATE)^N)$		
	$SNAOC = \sum_{I=1}^N NSTUD * ITRAV + N * IINSTR + N * IADMIN + IFACIL + NSUPPL + NMISC + NEQUIP + NIMD$	Calculate total annual operating costs non-discounted, discounted, const. and curmt \$.	SNAOC SIAOC SDAOC SFAOC
	also for $SDAOC = f(G, \dots), SIAOC = f(I, \dots), SFAOC = f(F, \dots)$		
	$GNAOC = SNAOC / \sum_{I=1}^N GRAD(I)$	Calculate average operating cost per graduate, non-discounted, discounted, const. and curmt \$.	GNAOC GIAOC GDAOC GFAOC
	also $GDAOC, GIAOC & GFAOC$		
	$PNAOC = SNAOC / \sum_{I=1}^N PSP(I)$	Calculate average operating cost per student position, non-discounted, discounted, const. and curmt \$.	PNAOC PIAOC PDAOC PFAOC
	also $PDAOC, PIAOC & PFAOC$		

o Non-Discounted Investment and Cost Savings Vector

INPUT	LOGIC	DESCRIPTION	OUTPUT
CEQUIP(1) FACST CUIMD	$ETAINV(1) = CEQUIP(1) + FACST + CUIMD$	Calculate first year of Investment vector	ETAINV(1)
CEQUIP(I)	$ETAINV(I) = CEQUIP(I) \text{ for } I = 2, N - 1$	Calculate subsequent years of Investment vector except for year N.	ETAINV(I)
CEQUIP(N) RVEQ RFVA RVIM	$ETAINV(N) = CEQUIP(N) - RVEQ - RFVA - RVIM$	Calculate Investment vector for year N. ETAINV(N)	
AEQUIP(I) COPMT(I) RFACIL(I) CPSQFT IIMDMT(I) CIMD CSTUD(I) CTRAV(I) CINSTR(I) CADMIN(I) CSUPPL(I) CMISC(I)	$ETAREC(I) = AEQUIP(I) * COPMT(I) + RFACIL * CPSQFT + IIMDMT(I) * CIMD + CSTUD(I) + CTRAV(I) + CINSTR(I) + CADMIN(I) + CSUPPL(I) + CMISC(I)$	Calculate Recurring Cost/Savings vector ETAREC(I)	

TAEG REPORT NO. 40

4. Prepare output reports for baseline calculations.
5. Retain non-discounted Investment ETAINV*, and non-discounted Cost/Savings ETAREC* vectors for completion of next sequence of calculations with benefit pattern applied.
6. Set up model to sequence through calculations using input from CMIB file.
7. Read input variables from first Entity Type 1 (Courses) record.
8. Perform calculations outlined in step 3 for new input variables.
9. Print output reports for calculations with benefits applied.
10. Subtract new ETAINV* and ETAREC* vectors from those retained in Step 5 to determine resultant Investment and Cost/Savings vectors to be written to the CMR file.
11. Repeat sequence 1 through 10 for remaining Type 1 Entities in the CMIA and CMIB files.

Output: Outputs from the Training Cost Model are presented in Figures III-28 through III-41. The example outputs are for an actual example which was run through the Cost Model. The upper part of each page designated course number ETA1 represents a path through the model without the benefit applied; e.g., attrition rate = .06. The lower part of each page designated as course number ETA2 represents a path through the model with the benefit applied; e.g., attrition rate = .04. The following is a list of the Training Cost Model outputs:

1. Input Technical Factors - Figure III-28
 2. Input Cost Factors - Figure III-29
 3. Output Technical Results - Figure III-30
 4. Output Technical Results, Years 1-5 - Figure III-31
 - Output Technical Results, Years 6-10 - Figure III-32
 - Output Technical Results, Years 11-15 - Figure III-33
 - Output Technical Results, Years 16-20 - Figure III-34
 5. Outputs Cost Results - Figure III-35
 6. Output Cost Results (Non-Discounted Constant Dollars), Years 1-5 - Figure III-36
 - Output Cost Results (Non-Discounted Constant Dollars), Years 6-10 - Figure III-37
 - Output Cost Results (Non-Discounted Constant Dollars), Years 11-15 - Figure III-38
 - Output Cost Results (Non-Discounted Constant Dollars), Years 16-20 - Figure III-39
 7. Figure III-40 displays the ETAM Technical and Cost Factors for Years 1-10. The final two lines of this report represent the Investment and Recurring Cost/Savings vectors which are written to the CMR file.
- Figure III-41 contains similar data for years 11-20. The data on these two figures represent the difference between pass 1 with the benefit not applied and pass 2 with the benefit applied.

The previous reports will serve as models for reports to be generated for Programs P53 and P54 which are the vehicles and job/tasks cost models.

COURSE COST ANALYSIS

INPUT:		COURSE NUMBER - ET42		DISCOUNT RATE - 10.0 PERCENT						
		PLANNING PERIOD - 2		INFLATION RATE - 6.0 PERCENT						
INPUT TECHNICAL FACTORS:										
PLNG YR	1	2	3	4	5	6	7	8	9	10
GRADS-	300	500	1000	2500	2500	2500	2500	2500	2500	2500
PLNG YR	11	12	13	14	15	16	17	18	19	20
GRADS-	2500	2500	2500	2500	2500	2000	1500	1000	500	250
ATTRITION RATE (PCT) - 0.06										
TRAINING LENGTH (WKS) - 2.0										
RECYCLE RATE (PCT) - 1.0										
WEEKS SCHOOL OPERATES - 50.0										
WEEKS/SCHOL OPERATES - 0.05										
INST/STUD POS RATIO - 9.00										
ADMIN/STUD POS RATIO - 3.00										
SQ FEET/STUDENT POS. - 2										
SQ FEET/INSTR. POS. - 1										
SQ FEET/ADMIN POS. - 50.0										
PURCHASE POLICY -										
DEPRECIATION POLICY -										
WEEKS SCHOOL AVAILABLE -										
TIME STUD POS DOWN (PCT) - 0.01										
PCT EXTRA STUD POSITIONS - 0.05										
EQUIP/STUD POS RATIO - 0.25										
TIME IN MEDIUM - 30.0										
COURSE DEV HRS/COURSE HR - 25.0										
PCT COURSE REQUIRING DEV. - 1.00										
PCT INSTR MAT. MAINTAINED - 1.20										
PCT INSTR MAT. RMNG VALUE - 0.40										
SUPPLIES/STUDENT - 1.00										
MISC/STUDENT - 1.00										

INPUT:		COURSE NUMBER - ET42		DISCOUNT RATE - 10.0 PERCENT						
		PLANNING PERIOD - 20		INFLATION RATE - 6.0 PERCENT						
INPUT TECHNICAL FACTORS:										
PLNG YR	1	2	3	4	5	6	7	8	9	10
GRADS-	300	500	1000	2500	2500	2500	2500	2500	2500	2500
PLNG YR	11	12	13	14	15	16	17	18	19	20
GRADS-	2500	2500	2500	2500	2500	2000	1500	1000	500	250
ATTRITION RATE (PCT) - 0.04										
TRAINING LENGTH (WKS) - 2.0										
RECYCLE RATE (PCT) - 1.0										
WEEKS SCHOOL OPERATES - 50.0										
WEEKS/SCHOL OPERATES - 0.05										
INST/STUD POS RATIO - 9.00										
ADMIN/STUD POS RATIO - 3.00										
SQ FEET/STUDENT POS. - 2										
SQ FEET/INSTR. POS. - 1										
SQ FEET/ADMIN POS. - 50.0										
PURCHASE POLICY -										
DEPRECIATION POLICY -										
WEEKS SCHOOL AVAILABLE -										
TIME STUD POS DOWN (PCT) - 0.01										
PCT EXTRA STUD POSITIONS - 0.05										
EQUIP/STUD POS RATIO - 0.25										
TIME IN MEDIUM - 30.0										
COURSE DEV HRS/COURSE HR - 25.0										
PCT COURSE REQUIRING DEV. - 1.00										
PCT INSTR MAT. MAINTAINED - 1.20										
PCT INSTR MAT. RMNG VALUE - 0.40										
SUPPLIES/STUDENT - 1.00										
MISC/STUDENT - 1.00										

FIGURE III-28. TRAINING COST MODEL-INPUT TECHNICAL FACTORS

COURSE COST ANALYSIS

INPUT:
 COURSE NUMBER = ETAL
 PLANNING PERIOD = 2.

DISCOUNT RATE = 12.0 PERCENT
 INFLATION RATE = 6.0 PERCENT

INPUT COST FACTORS:	1	2	3	4	5	6	7	8	9
PLNG YR	100.	100.	100.	100.	100.	100.	100.	100.	100.
DEMN-	11	12	13	14	15	16	17	18	19
DEMN-	100.	100.	100.	100.	100.	100.	100.	100.	100.
STUDENT SALARY (ANNUAL)	-	-	-	11141.00	-	-	-	-	-
STUD TRAVEL TU/FRUM	-	-	-	228.00	-	-	-	-	-
STUD TRAVEL IN COURSE	-	-	-	0.00	-	-	-	-	-
INSTR SALARY (ANNUAL)	-	-	-	16240.00	-	-	-	-	-
ADMIN SALARY (ANNUAL)	-	-	-	13500.00	-	-	-	-	-
EQUIPMENT UNIT COST	-	-	-	4000.00	-	-	-	-	-
FACIL INIT/REFURB COST	-	-	-	0.00	-	-	-	-	-
COST/HR OF INSTR MAT DEV	-	-	-	-	-	-	-	-	6.00
SUPPLIES COST	-	-	-	-	-	-	-	-	10.00
MISCELLANEOUS COST	-	-	-	-	-	-	-	-	0.00
PCT MAX EQUIP PURCHASED	-	-	-	-	-	-	-	-	25.00
FACILITY COST/SQ FOOT	-	-	-	-	-	-	-	-	10
LIFE OF EQUIPMENT	-	-	-	-	-	-	-	-	20
LIFE OF FACILITY	-	-	-	-	-	-	-	-	-

COURSE COST ANALYSIS

INPUT:
 COURSE NUMBER = ETAL
 PLANNING PERIOD = 2.

DISCOUNT RATE = 10.0 PERCENT
 INFLATION RATE = 6.0 PERCENT

INPUT COST FACTORS:	1	2	3	4	5	6	7	8	9
PLNG YR	100.	100.	100.	100.	100.	100.	100.	100.	100.
DEMN-	11	12	13	14	15	16	17	18	19
DEMN-	100.	100.	100.	100.	100.	100.	100.	100.	100.
STUDENT SALARY (ANNUAL)	-	-	-	11141.00	-	-	-	-	-
STUD TRAVEL TU/FRUM	-	-	-	228.00	-	-	-	-	-
STUD TRAVEL IN COURSE	-	-	-	0.00	-	-	-	-	-
INSTR SALARY (ANNUAL)	-	-	-	16240.00	-	-	-	-	-
ADMIN SALARY (ANNUAL)	-	-	-	13500.00	-	-	-	-	-
EQUIPMENT UNIT COST	-	-	-	4000.00	-	-	-	-	-
FACIL INIT/REFURB COST	-	-	-	0.00	-	-	-	-	-
COST/HR OF INSTR MAT DEV	-	-	-	-	-	-	-	-	6.00
SUPPLIES COST	-	-	-	-	-	-	-	-	10.00
MISCELLANEOUS COST	-	-	-	-	-	-	-	-	0.00
PCT MAX EQUIP PURCHASED	-	-	-	-	-	-	-	-	25.00
FACILITY COST/SQ FOOT	-	-	-	-	-	-	-	-	10
LIFE OF EQUIPMENT	-	-	-	-	-	-	-	-	20
LIFE OF FACILITY	-	-	-	-	-	-	-	-	-

FIGURE III-29. TRAINING COST MODEL-INPUT COST FACTORS

COURSE COST ANALYSIS

INPUT:
 COURSE NUMBER - ETAL
 PLANNING PERIOD - 20

DISCOUNT RATE - 10.0 PERCENT
 INFLATION RATE - 6.0 PERCENT

OUTPUT TECHNICAL RESULTS:

AVE. NO. OF GRADUATES RQD	1852.0
AVE. NO. OF STUDENTS IN	1970.7
AVE. AVERAGE ON BOARD	80.4
AVE. NO. OF STUDENT POSITIONS	85.0
AVE. NO. OF INSTRUCTORS RQD	4.3
AVE. NO. OF ADMIN PERS RQD	0.3
AVE. NO. OF EQUIP PURCHASES	21.3
AVE. ANNUAL EQUIP AVAILABLE	2.6
AVE. NO. SQUARE FEET RQD	27.3
AVE. INSTR. MAT. MAINT HK RQD	791.4
AVE. NO. SUPPLIES RQD	300.0
AVE. NO. MISCELLANEOUS RQD	2556.2
	2056.0

COURSE COST ANALYSIS

INPUT:
 COURSE NUMBER - ETAL
 PLANNING PERIOD - 20

DISCOUNT RATE - 10.0 PERCENT
 INFLATION RATE - 6.0 PERCENT

OUTPUT TECHNICAL RESULTS:

AVE. NO. OF GRADUATES RQD	1852.0
AVE. NO. OF STUDENTS IN	1929.7
AVE. AVERAGE ON BOARD	79.5
AVE. NO. OF STUDENT POSITIONS	83.0
AVE. NO. OF INSTRUCTORS RQD	4.2
AVE. NO. OF ADMIN PERS RQD	0.8
AVE. NO. OF EQUIP PURCHASES	42.2
AVE. ANNUAL EQUIP AVAILABLE	5.1
AVE. NO. SQUARE FEET RQD	53.5
AVE. INSTR. MAT. MAINT HK RQD	782.5
AVE. NO. SUPPLIES RQD	300.0
AVE. NO. MISCELLANEOUS RQD	2014.0
	2014.0

FIGURE III-30. TRAINING COST MODEL-OUTPUT TECHNICAL RESULTS

COURSE COST ANALYSIS

INPUT:
 COURSE NUMBER = ETAE
 PLANNING PERIOD = 2

DISCOUNT RATE = 10.0 PERCENT
 INFLATION RATE = 6.0 PERCENT

OUTPUT TECHNICAL RESULTS:

	YEAR 1	YEAR 2	YEAR 3	YEAR 4	YEAR 5
NO. OF GRADUATES RQD	300	500	1000	2500	2500
NO. OF STUDENTS IN	319.	532.	1064.	2660.	2660.
AVERAGE OF BOARD	13.	22.	43.	109.	109.
NO. OF STUDENT POSITIONS	14.	23.	46.	115.	115.
NO. OF INSTRUCTORS RQD	1.	1.	2.	6.	6.
NO. OF ADMIN PERS RQD	0.	0.	0.	1.	1.
NO. OF EQUIPMENTS RQD	3.	6.	12.	29.	29.
ANNUAL EQUIP PURCHASES	26.	50.	96.	260.	260.
ANNUAL EQUIP AVAILABLE	26.	26.	26.	26.	26.
NO. SQUARE FEET RQD	128.	214.	427.	1068.	1068.
NO. INSTR MAT MAINT HR RQD	300.	500.	1000.	2500.	2500.
NO. SUPPLIES RQD	333.	555.	1110.	2775.	2775.
NO. MISCELLANEOUS RQD	333.	555.	1110.	2775.	2775.

COURSE COST ANALYSIS

INPUT:
 COURSE NUMBER = ETAE
 PLANNING PERIOD = 2

DISCOUNT RATE = 10.0 PERCENT
 INFLATION RATE = 6.0 PERCENT

OUTPUT TECHNICAL RESULTS:

	YEAR 1	YEAR 2	YEAR 3	YEAR 4	YEAR 5
NO. OF GRADUATES RQD	300	500	1000	2500	2500
NO. OF STUDENTS IN	312.	521.	1042.	2604.	2604.
AVERAGE OF BOARD	13.	21.	43.	107.	107.
NO. OF STUDENT POSITIONS	14.	23.	46.	114.	114.
NO. OF INSTRUCTORS RQD	1.	1.	2.	6.	6.
NO. OF ADMIN PERS RQD	0.	0.	0.	1.	1.
NO. OF EQUIPMENTS RQD	7.	11.	23.	57.	57.
ANNUAL EQUIP PURCHASES	51.	51.	51.	51.	51.
ANNUAL EQUIP AVAILABLE	51.	51.	51.	51.	51.
NO. SQUARE FEET RQD	127.	211.	422.	1056.	1056.
NO. INSTR MAT MAINT HR RQD	300.	500.	1000.	2500.	2500.
NO. SUPPLIES RQD	326.	544.	1087.	2718.	2718.
NO. MISCELLANEOUS RQD	326.	544.	1087.	2718.	2718.

FIGURE III-31. TRAINING COST MODEL-OUTPUT TECHNICAL RESULTS YEARS 1 - 5

COURSE COST ANALYSIS

INPUT:
 COURSE NUMBER - E1A1
 PLANNING PERIOD - 20

DISCOUNT RATE - 10.0 PERCENT
 INFLATION RATE - 6.0 PERCENT

OUTPUT TECHNICAL RESULTS:

	YEAR 5	YEAR 7	YEAR 8	YEAR 9	YEAR 10
NO. OF GRADUATES RQD	2500	2500	2500	2500	2500
NO. OF STUDENTS IN	2660.	2660.	2660.	2660.	2660.
AVERAGE ON BOARD	109.	109.	109.	109.	109.
NO. OF STUDENT POSITIONS	115.	115.	115.	115.	115.
NO. OF INSTRUCTORS RQD	6.	6.	6.	6.	6.
NO. OF ADMIN PERS RQD	1.	1.	1.	1.	1.
NO. OF EQUIPMENTS RQD	29.	29.	29.	29.	29.
ANNUAL EQUIP PURCHASES	0.	0.	0.	0.	0.
ANNUAL EQUIP AVAILABLE	26	26	26	26	26
NO. SQUARE FEET RQD	1068.	1068.	1068.	1068.	1068.
NO. INSTR MAT MAINT HR RQD	300.	300.	300.	300.	300.
NO. SUPPLIES RQD	2775.	2775.	2775.	2775.	2775.
NO. MISCELLANEOUS RQD	2775.	2775.	2775.	2775.	2775.

COURSE COST ANALYSIS

INPUT:
 COURSE NUMBER - E1A2
 PLANNING PERIOD - 20

DISCOUNT RATE - 10.0 PERCENT
 INFLATION RATE - 6.0 PERCENT

OUTPUT TECHNICAL RESULTS:

	YEAR 6	YEAR 7	YEAR 8	YEAR 9	YEAR 10
NO. OF GRADUATES RQD	2500	2500	2500	2500	2500
NO. OF STUDENTS IN	2604.	2604.	2604.	2604.	2604.
AVERAGE ON BOARD	107.	107.	107.	107.	107.
NO. OF STUDENT POSITIONS	114.	114.	114.	114.	114.
NO. OF INSTRUCTORS RQD	6.	6.	6.	6.	6.
NO. OF ADMIN PERS RQD	1.	1.	1.	1.	1.
NO. OF EQUIPMENTS RQD	57.	57.	57.	57.	57.
ANNUAL EQUIP PURCHASES	0.	0.	0.	0.	0.
ANNUAL EQUIP AVAILABLE	21	21	21	21	21
NO. SQUARE FEET RQD	1056.	1056.	1056.	1056.	1056.
NO. INSTR MAT MAINT HR RQD	300.	300.	300.	300.	300.
NO. SUPPLIES RQD	2718.	2718.	2718.	2718.	2718.
NO. MISCELLANEOUS RQD	2718.	2718.	2718.	2718.	2718.

FIGURE III-32. TRAINING COST MODEL-OUTPUT TECHNICAL RESULTS YEARS 6 - 10

COURSE COST ANALYSIS

DISCOUNT RATE = 10.0 PERCENT
INFLATION RATE = 6.0 PERCENT

INPUT:
COURSE NUMBER = 25
PLANNING PERIOD = 20

OUTPUT TECHNICAL RESULTS:

	YEAR 11	YEAR 12	YEAR 13	YEAR 14	YEAR 15
NU. OF GRADUATES RQD	2500	2500	2500	2500	2500
NU. OF STUDENTS IN	2660	2660	2660	2660	2660
AVERAGE ON BOARD	109.	109.	109.	109.	109.
NU. OF STUDENT POSITIONS	115.	115.	115.	115.	115.
NU. OF INSTRUCTORS RQD	6.	6.	6.	6.	6.
NU. OF ADMIN PERS RQD	1.	1.	1.	1.	1.
NU. OF EQUIPMENTS RQD	29.	29.	29.	29.	29.
ANNUAL EQUIP PURCHASES	26.	26.	26.	26.	26.
ANNUAL EQUIP AVAILABLE	1068.	1068.	1068.	1068.	1068.
NU. SQUARE FEET RQD	300.	300.	300.	300.	300.
NU. INSTR MAT MAINT HR RQD	2775.	2775.	2775.	2775.	2775.
NU. SUPPLIES RQD	2775.	2775.	2775.	2775.	2775.
NU. MISCELLANEOUS RQD					

COURSE COST ANALYSIS

DISCOUNT RATE = 10.0 PERCENT
INFLATION RATE = 6.0 PERCENT

INPUT:
COURSE NUMBER = 25A2
PLANNING PERIOD = 20

OUTPUT TECHNICAL RESULTS:

	YEAR 11	YEAR 12	YEAR 13	YEAR 14	YEAR 15
NU. OF GRADUATES RQD	2500	2500	2500	2500	2500
NU. OF STUDENTS IN	2604.	2604.	2604.	2604.	2604.
AVERAGE ON BOARD	107.	107.	107.	107.	107.
NU. OF STUDENT POSITIONS	114.	114.	114.	114.	114.
NU. OF INSTRUCTORS RQD	6.	6.	6.	6.	6.
NU. OF ADMIN PERS RQD	1.	1.	1.	1.	1.
NU. OF EQUIPMENTS RQD	57.	57.	57.	57.	57.
ANNUAL EQUIP PURCHASES	51.	51.	51.	51.	51.
ANNUAL EQUIP AVAILABLE	1056.	1056.	1056.	1056.	1056.
NU. SQUARE FEET RQD	300.	300.	300.	300.	300.
NU. INSTR MAT MAINT HR RQD	2718.	2718.	2718.	2718.	2718.
NU. SUPPLIES RQD	2718.	2718.	2718.	2718.	2718.
NU. MISCELLANEOUS RQD					

FIGURE III-33. TRAINING COST MODEL-OUTPUT TECHNICAL RESULTS YEARS 11 - 15

COURSE COST ANALYSIS

INPUT:
COURSE NUMBER - ETAL
PLANNING PERIOD - 23

DISCOUNT RATE - 10.0 PERCENT
INFLATION RATE - 6.0 PERCENT

OUTPUT TECHNICAL RESULTS:

	YEAR 15	YEAR 17	YEAR 18	YEAR 19	YEAR 20
NO. OF GRADUATES RQD	2000	1500	1000	500	250
NO. OF STUDENTS IN	2128	1596	1064	532	266
AVERAGE ON BOARD	87	65	43	22	11
NO. OF STUDENT POSITIONS	92	69	46	23	12
NO. OF INSTRUCTORS RQD	5	3	2	1	0
NO. OF ADMIN PERS RQD	1	1	0	0	0
NO. OF EQUIPMENTS RQD	23	17	12	9	3
ANNUAL EQUIP PURCHASES	26	26	26	26	26
ANNUAL EQUIP AVAILABLE	854	641	427	214	107
NO. SQUARE FEET RQD	300	300	300	300	300
NO. INSTR MAT MAINT HR RQD	2220	1665	1110	555	277
NO. SUPPLIES RQD					
NO. MISCELLANEOUS RQD					

COURSE COST ANALYSIS

INPUT:
COURSE NUMBER - ETAL
PLANNING PERIOD - 23

DISCOUNT RATE - 10.0 PERCENT
INFLATION RATE - 6.0 PERCENT

OUTPUT TECHNICAL RESULTS:

	YEAR 15	YEAR 17	YEAR 18	YEAR 19	YEAR 20
NO. OF GRADUATES RQD	2000	1500	1000	500	250
NO. OF STUDENTS IN	2083	1562	1042	521	260
AVERAGE ON BOARD	86	64	43	23	11
NO. OF STUDENT POSITIONS	91	68	46	23	11
NO. OF INSTRUCTORS RQD	5	3	2	1	0
NO. OF ADMIN PERS RQD	1	1	0	0	0
NO. OF EQUIPMENTS RQD	46	34	23	11	6
ANNUAL EQUIP PURCHASES	0	0	0	0	0
ANNUAL EQUIP AVAILABLE	51	51	51	51	51
NO. SQUARE FEET RQD	845	634	422	211	106
NO. INSTR MAT MAINT HR RQD	300	300	300	300	300
NO. SUPPLIES RQD	2174	1631	1087	544	272
NO. MISCELLANEOUS RQD	2174	1631	1087	544	272

FIGURE III-34. TRAINING COST MODEL-OUTPUT TECHNICAL RESULTS YEARS 16 - 20

COURSE COST ANALYSIS

INPUT:
COURSE NUMBER = ETAL
PLANNING PERIOD = 20

DISCOUNT RATE = 10.0 PERCENT
INFLATION RATE = 6.0 PERCENT

OUTPUT COST RESULTS:	NON-DISC CONSTANT \$	DISCOUNTED CONSTANT \$	NON-DISC CURRENT \$	DISCOUNTED CURRENT \$
STUDENT SALARIES	1722704.0	7453212.0	31420736.0	12184789.0
STUDENT TRAVEL	898658.3	3888009.0	16395844.0	6356265.0
INSTRUCTOR SALARY	1384934.0	579187.0	2526010.0	979573.0
ADMINISTRATIVE SALARY	233254.0	9618.0	419955.0	162860.0
EQUIPMENT	26000.0	160789.0	397126.0	209457.0
FACILITIES	395695.0	171136.0	721718.0	279878.0
INSTRUCTIONAL MATERIALS	4120.0	24120.0	66195.0	32537.0
SUPPLIES	41120.0	177906.0	750005.0	290847.0
MISCELLANEOUS	0.0	0.0	0.0	0.0
TOTAL OPERATIONAL	28937056.0	12574032.0	52692544.0	20495144.0
COST PER GRADUATE	781.03	339.38	1422.20	553.20
COST PER STUDENT	734.17	319.02	1336.87	520.01
COST PER STUDENT POSITION	16991.81	7383.46	30941.01	12035.32

COURSE COST ANALYSIS

INPUT:
COURSE NUMBER = ET42
PLANNING PERIOD = 20

DISCOUNT RATE = 10.0 PERCENT
INFLATION RATE = 6.0 PERCENT

OUTPUT COST RESULTS:	NON-DISC CONSTANT \$	DISCOUNTED CONSTANT \$	NON-DISC CURRENT \$	DISCOUNTED CURRENT \$
STUDENT SALARIES	17033504.0	7369491.0	31067760.0	12047903.0
STUDENT TRAVEL	879935.0	3807009.0	16049366.0	6223842.0
INSTRUCTOR SALARY	1369374.0	592456.0	2497631.0	968568.0
ADMINISTRATIVE SALARY	227657.0	98499.0	415247.0	161030.0
EQUIPMENT	51000.0	315394.0	778979.0	410858.0
FACILITIES	40125.0	178818.0	723902.0	286557.0
INSTRUCTIONAL MATERIALS	4140.0	24120.0	66195.0	32537.0
SUPPLIES	40280.0	174270.0	734679.0	284904.0
MISCELLANEOUS	0.0	0.0	0.0	0.0
TOTAL OPERATIONAL	28785312.0	12560044.0	52333696.0	20416144.0
COST PER GRADUATE	776.93	339.00	1412.52	551.04
COST PER STUDENT	745.85	325.44	1356.02	520.00
COST PER STUDENT POSITION	17205.80	7507.50	31281.35	12203.31

FIGURE III-35. TRAINING COST MODEL-OUTPUT COST RESULTS

COURSE COST ANALYSIS

INPUT:
COURSE NUMBER - ETAL
PLANNING PERIOD - 2J

DISCOUNT RATE - 10.0 PERCENT
INFLATION RATE - 6.0 PERCENT

OUTPUT COST RESULTS: (NON-DISC CONSTANT \$)

	YEAR 1	YEAR 2	YEAR 3	YEAR 4	YEAR 5
STUDENT SALARIES	139430.	232484.	464368.	1162419.	1162419.
STUDENT TRAVEL	72760.	121277.	242553.	606383.	606383.
INSTRUCTOR SALARY	11214.	13690.	37380.	93450.	93450.
ADMINISTRATIVE SALARY	1664.	3157.	6215.	15537.	15537.
EQUIPMENT	106600.	2600.	2600.	2600.	2600.
FACILITIES	3254.	5340.	10680.	26700.	26700.
INSTRUCTIONAL MATERIALS	10850.	1800.	1800.	1800.	1800.
SUPPLIES	3330.	5543.	11099.	27747.	27747.
MISCELLANEOUS	0.	0.	0.	0.	0.
TOTAL OPERATIONAL	349268.	390847.	777295.	1936632.	1936632.
COST PER GRADUATE	1164.	782.	777.	775.	775.
COST PER STUDENT INPUT	1094.	735.	731.	728.	728.
COST PER STUDENT POSITION	25230.	16981.	16885.	16828.	16828.

COURSE COST ANALYSIS

INPUT:
COURSE NUMBER - ETAL
PLANNING PERIOD - 2J

DISCOUNT RATE - 10.0 PERCENT
INFLATION RATE - 6.0 PERCENT

OUTPUT COST RESULTS: (NON-DISC CONSTANT \$)

	YEAR 1	YEAR 2	YEAR 3	YEAR 4	YEAR 5
STUDENT SALARIES	137923.	229872.	459745.	1149360.	1149360.
STUDENT TRAVEL	71250.	118750.	237500.	593750.	593750.
INSTRUCTOR SALARY	11088.	13480.	36960.	92401.	92401.
ADMINISTRATIVE SALARY	1643.	3072.	6145.	15362.	15362.
EQUIPMENT	209100.	5100.	5100.	5100.	5100.
FACILITIES	13168.	5280.	10560.	26400.	26400.
INSTRUCTIONAL MATERIALS	10850.	1800.	1800.	1800.	1800.
SUPPLIES	3262.	5436.	10872.	27180.	27180.
MISCELLANEOUS	0.	0.	0.	0.	0.
TOTAL OPERATIONAL	458434.	387790.	768681.	1911349.	1911349.
COST PER GRADUATE	1528.	776.	769.	765.	765.
COST PER STUDENT INPUT	1467.	745.	738.	734.	734.
COST PER STUDENT POSITION	33572.	17039.	16888.	16797.	16797.

FIGURE III-36. TRAINING COST MODEL-OUTPUT COST RESULTS YEARS 1 - 5

COURSE COST ANALYSIS

INPUT:
COURSE NUMBER = ETAI
PLANNING PERIOD = 20

DISCOUNT RATE = 10.0 PERCENT
INFLATION RATE = 6.0 PERCENT

OUTPUT COST RESULTS: (NON-DISC CONSTANT \$)

	YEAR 5	YEAR 7	YEAR 8	YEAR 9	YEAR 10
STUDENT SALARIES	1162419.	1162419.	1162419.	1162419.	1162419.
STUDENT TRAVEL	606383.	606383.	606383.	606383.	606383.
INSTRUCTOR SALARY	93450.	93450.	93450.	93450.	93450.
ADMINISTRATIVE SALARY	15537.	15537.	15537.	15537.	15537.
EQUIPMENT	2600.	2600.	2600.	2600.	2600.
FACILITIES	26700.	26700.	26700.	26700.	26700.
INSTRUCTIONAL MATERIALS	1800.	1800.	1800.	1800.	1800.
SUPPLIES	27747.	27747.	27747.	27747.	27747.
MISCELLANEOUS	0.	0.	0.	0.	0.
TOTAL OPERATIONAL	1936632.	1936632.	1936632.	1936632.	1936632.
COST PER GRADUATE	775.	775.	775.	775.	775.
COST PER STUDENT INPUT	728.	728.	728.	728.	728.
COST PER STUDENT POSITION	16828.	16828.	16828.	16828.	16828.

COURSE COST ANALYSIS

INPUT:
COURSE NUMBER = ETAI
PLANNING PERIOD = 20

DISCOUNT RATE = 10.0 PERCENT
INFLATION RATE = 6.0 PERCENT

OUTPUT COST RESULTS: (NON-DISC CONSTANT \$)

	YEAR 5	YEAR 7	YEAR 8	YEAR 9	YEAR 10
STUDENT SALARIES	1149360.	1149360.	1149360.	1149360.	1149360.
STUDENT TRAVEL	593750.	593750.	593750.	593750.	593750.
INSTRUCTOR SALARY	92401.	92401.	92401.	92401.	92401.
ADMINISTRATIVE SALARY	15362.	15362.	15362.	15362.	15362.
EQUIPMENT	5100.	5100.	5100.	5100.	5100.
FACILITIES	26400.	26400.	26400.	26400.	26400.
INSTRUCTIONAL MATERIALS	1800.	1800.	1800.	1800.	1800.
SUPPLIES	27180.	27180.	27180.	27180.	27180.
MISCELLANEOUS	0.	0.	0.	0.	0.
TOTAL OPERATIONAL	1911349.	1911349.	1911349.	1911349.	1911349.
COST PER GRADUATE	765.	765.	765.	765.	765.
COST PER STUDENT INPUT	734.	734.	734.	734.	734.
COST PER STUDENT POSITION	16797.	16797.	16797.	16797.	16797.

FIGURE III-37. TRAINING COST MODEL-OUTPUT COST RESULTS YEARS 6 - 10

COURSE COST ANALYSIS

INPUT:
 COURSE NUMBER = ETAL
 PLANNING PERIOD = 20

DISCOUNT RATE = 10.0 PERCENT
 INFLATION RATE = 6.0 PERCENT

OUTPUT COST RESULTS: (NET-DISC CONSTANT \$)

	YEAR 11	YEAR 12	YEAR 13	YEAR 14	YEAR 15
STUDENT SALARIES	1162419.	1162419.	1162419.	1162419.	1162419.
STUDENT TRAVEL	606383.	606383.	606383.	606383.	606383.
INSTRUCTOR SALARY	93450.	93450.	93450.	93450.	93450.
ADMINISTRATIVE SALARY	15537.	15537.	15537.	15537.	15537.
EQUIPMENT	10600.	2600.	2600.	2600.	2600.
FACILITIES	26700.	26700.	26700.	26700.	26700.
INSTRUCTIONAL MATERIALS	1800.	1800.	1800.	1800.	1800.
SUPPLIES	27747.	27747.	27747.	27747.	27747.
MISCELLANEOUS	0.	0.	0.	0.	0.
TOTAL OPERATIONAL	240632.	1936632.	1936632.	1936632.	1936632.
COST PER GRADUATE	816.	775.	775.	775.	775.
COST PER STUDENT INPUT	767.	728.	728.	728.	728.
COST PER STUDENT POSITION	17731.	16828.	16828.	16828.	16828.

COURSE COST ANALYSIS

INPUT:
 COURSE NUMBER = ETAL
 PLANNING PERIOD = 20

DISCOUNT RATE = 10.0 PERCENT
 INFLATION RATE = 6.0 PERCENT

OUTPUT COST RESULTS: (NET-DISC CONSTANT \$)

	YEAR 11	YEAR 12	YEAR 13	YEAR 14	YEAR 15
STUDENT SALARIES	1149360.	1149360.	1149360.	1149360.	1149360.
STUDENT TRAVEL	593750.	593750.	593750.	593750.	593750.
INSTRUCTOR SALARY	92401.	92401.	92401.	92401.	92401.
ADMINISTRATIVE SALARY	15362.	15362.	15362.	15362.	15362.
EQUIPMENT	209100.	5100.	5100.	5100.	5100.
FACILITIES	26400.	26400.	26400.	26400.	26400.
INSTRUCTIONAL MATERIALS	1800.	1800.	1800.	1800.	1800.
SUPPLIES	27180.	27180.	27180.	27180.	27180.
MISCELLANEOUS	0.	0.	0.	0.	0.
TOTAL OPERATIONAL	2115349.	1911349.	1911349.	1911349.	1911349.
COST PER GRADUATE	846.	765.	765.	765.	765.
COST PER STUDENT INPUT	812.	734.	734.	734.	734.
COST PER STUDENT POSITION	18549.	16797.	16797.	16797.	16797.

FIGURE III-38. TRAINING COST MODEL-OUTPUT COST RESULTS YEARS 11 - 15

COURSE COST ANALYSIS

INPUT:
 COURSE NUMBER = 6142
 PLANNING PERIOD = 20

DISCOUNT RATE = 10.0 PERCENT
 INFLATION RATE = 6.0 PERCENT

OUTPUT COST RESULTS: (NO)-DISC CONSTANT \$)

	YEAR 16	YEAR 17	YEAR 18	YEAR 19	YEAR 20
STUDENT SALARIES	929935.	697452.	464968.	232484.	116242.
STUDENT TRAVEL	485106.	363830.	242553.	121277.	60638.
INSTRUCTOR SALARY	74760.	56070.	37380.	18690.	9345.
ADMINISTRATIVE SALARY	12429.	9322.	6215.	3137.	1554.
EQUIPMENT	2600.	2600.	2600.	2600.	2600.
FACILITIES	21360.	16020.	10680.	5340.	2670.
INSTRUCTIONAL MATERIALS	1800.	1800.	1800.	1800.	-1800.
SUPPLIES	22197.	16648.	11599.	5549.	2775.
MISCELLANEOUS	0.	0.	0.	0.	0.
TOTAL OPERATIONAL	1550186.	1163739.	777495.	390847.	194223.
COST PER GRADUATE	775.	776.	777.	782.	776.
COST PER STUDENT INPUT	729.	729.	731.	735.	730.
COST PER STUDENT POSITION	16837.	16853.	16885.	16981.	16859.

COURSE COST ANALYSIS

INPUT:
 COURSE NUMBER = 6142
 PLANNING PERIOD = 20

DISCOUNT RATE = 10.0 PERCENT
 INFLATION RATE = 6.0 PERCENT

OUTPUT COST RESULTS: (NO)-DISC CONSTANT \$)

	YEAR 16	YEAR 17	YEAR 18	YEAR 19	YEAR 20
STUDENT SALARIES	919489.	689617.	459745.	229872.	114936.
STUDENT TRAVEL	475000.	356250.	237500.	118750.	59375.
INSTRUCTOR SALARY	73921.	55440.	36960.	18480.	9240.
ADMINISTRATIVE SALARY	12270.	9217.	6145.	3072.	1536.
EQUIPMENT	5100.	5100.	5100.	5100.	5100.
FACILITIES	21120.	15840.	10560.	5280.	2640.
INSTRUCTIONAL MATERIALS	1800.	1800.	1800.	1800.	-1800.
SUPPLIES	21744.	16308.	10872.	5436.	2718.
MISCELLANEOUS	0.	0.	0.	0.	0.
TOTAL OPERATIONAL	1530459.	1149570.	768681.	387730.	193745.
COST PER GRADUATE	765.	766.	769.	776.	775.
COST PER STUDENT INPUT	735.	736.	738.	745.	744.
COST PER STUDENT POSITION	16812.	16837.	16888.	17039.	17026.

FIGURE III-39. TRAINING COST MODEL-OUTPUT COST RESULTS YEARS 16 - 20

ETAM OUTPUT FACTORS

	YEAR 1	YEAR 2	YEAR 3	YEAR 4	YEAR 5
NU. OF GRADUATES RQD	9.	9.	9.	9.	0.
NU. OF STUDENTS IN AVERAGE ON BOARD	7.	11.	22.	55.	55.
NU. OF INSTRUCTORS RQD	0.	0.	0.	1.	1.
NU. OF ADMIN PERS RQD	0.	0.	0.	0.	0.
NU. OF EQUIPMENTS RQD	-3.	-6.	-11.	-28.	-28.
NU. SQUARE FEET RQD	1.	2.	5.	12.	12.
NU. SUPPLIES RQD	7.	11.	23.	57.	57.
NU. MISCELLANEOUS RQD	7.	11.	23.	57.	57.
ANNUAL INVESTMENT DOLLARS	-1,000.	0.	0.	0.	0.
ANNUAL RECURRING CST/SAV	834.	3057.	8613.	25283.	25283.

ETAM OUTPUT FACTORS

	YEAR 5	YEAR 7	YEAR 8	YEAR 9	YEAR 10
NU. OF GRADUATES RQD	0.	0.	0.	0.	0.
NU. OF STUDENTS IN AVERAGE ON BOARD	55.	55.	55.	55.	55.
NU. OF INSTRUCTORS RQD	1.	1.	1.	1.	1.
NU. OF ADMIN PERS RQD	0.	0.	0.	0.	0.
NU. OF EQUIPMENTS RQD	-28.	-28.	-28.	-28.	-28.
NU. SQUARE FEET RQD	12.	12.	12.	12.	12.
NU. SUPPLIES RQD	57.	57.	57.	57.	57.
NU. MISCELLANEOUS RQD	57.	57.	57.	57.	57.
ANNUAL INVESTMENT DOLLARS	0.	0.	0.	0.	0.
ANNUAL RECURRING CST/SAV	25283.	25283.	25283.	25283.	25283.

FIGURE III-40. TRAINING COST MODEL/ETAM OUTPUT FACTORS YEARS 1 - 10

ETAM OUTPUT FACTORS						
	YEAR 11	YEAR 12	YEAR 13	YEAR 14	YEAR 15	
NO. OF GRADUATES RQD	0.	0.	0.	0.	0.	
NO. OF STUDENTS IN	55.	55.	55.	55.	55.	
AVERAGE OF BOARD	1.	1.	1.	1.	1.	
NO. OF INSTRUCTORS RQD	0.	0.	0.	0.	0.	
NO. OF ADMIN PERS RQD	-28.	-28.	-28.	-28.	-28.	
NO. OF EQUIPMENTS RQD	12.	12.	12.	12.	12.	
NO. SQUARE FEET RQD	57.	57.	57.	57.	57.	
NO. SUPPLIES RQD	57.	57.	57.	57.	57.	
NO. MISCELLANEOUS RQD	0.	0.	0.	0.	0.	
ANNUAL INVESTMENT DOLLARS	-122000.	0.	0.	0.	0.	
ANNUAL RECURRING COST/SAV	25283.	25283.	25283.	25283.	25283.	25283.

ETAM OUTPUT FACTORS						
	YEAR 16	YEAR 17	YEAR 18	YEAR 19	YEAR 20	
NO. OF GRADUATES RQD	0.	0.	0.	0.	0.	
NO. OF STUDENTS IN	44.	33.	22.	11.	0.	
AVERAGE OF BOARD	1.	1.	0.	0.	0.	
NO. OF INSTRUCTORS RQD	0.	0.	0.	0.	0.	
NO. OF ADMIN PERS RQD	-23.	-17.	-11.	-9.	-3.	
NO. OF EQUIPMENTS RQD	10.	7.	5.	2.	1.	
NO. SQUARE FEET RQD	42.	34.	23.	11.	6.	
NO. SUPPLIES RQD	45.	34.	23.	11.	6.	
NO. MISCELLANEOUS RQD	0.	0.	0.	0.	0.	
ANNUAL INVESTMENT DOLLARS	19727.	14170.	8613.	3057.	278.	
ANNUAL RECURRING COST/SAV	0.	0.	0.	0.	0.	

FIGURE III-41. TRAINING COST MODEL-ETAM OUTPUT FACTORS YEARS 11 - 20

Program P53 (Vehicles Cost Model).

Purpose: The Vehicles Cost Model calculates the delta cost effect from the innovation benefit pattern associated with some instructional vehicle. Since the intended pattern of benefits with respect to instructional vehicles is one of cost displacement, the model is relatively simple. The objective as was with the Training Cost Model is to create two 20 year dollar vectors, one for investment and a second for cost/savings.

Input: The data input variables required to run the Vehicles Cost Model were set up by Program P51. The baseline input variables are contained in the Cost Models Inputs W/O Benefits (CMIA) file and would generally reflect the EXV file unless modified by Program P51. The input variables with benefits applied as set up by Program P51 are contained in the Cost Models Input with Benefits (CMIB) file.

The input variables are the same as described in Figure III-7 EXV DATA ELEMENTS.

Process: The major program process steps are:

1. Setup model to sequence through calculations using input from the CMIA file.
2. Read input variables from first Entity Type 2 (Vehicles) record.
3. Calculate:

- o Available Equipment annually over Planning Period

$$AEQUIP(J) = \sum_{J=N}^1 \sum_{I=J-LOFEQ}^J PEQUIP(I)$$

- o Purchase Cost Annually

$$CEQUIP(I) = PEQUIP(I) * EQUNTC$$

- o Maintenance Costs Annually

$$MEQUIP(I) = AEQUIP(I) * COPMT(I)$$

- o Installation Costs Annually

$$IEQUC(I) = PEQUIP(I) * EQINSC$$

- o Remaining Value of Equipment

$$RVEQ = \sum_{I=1}^N CEQUIP(I) * PDEP(LIFERV)$$

for LIFERV 0

where LIFERV = I + LOFEQ - N - 1

and PDEP (LIFERV) = f[DEPE] (LOFEQ)

- o Percent Depreciation per Depreciation Policy
The Depreciation Policies for which PDEP(I) is calculated are:

T A E G R E P O R T N O . 4 0

1) Linearly over life of equipment

$$PDEP(I) = I/LOFEQ \text{ for } I = 1 \text{ to } LOFEQ$$

2) Sum-of-Digits over life of equipment

$$SUM = \sum_{I=1}^{LOFEQ} SUM+1 \text{ where } SUM = 0 \text{ initially}$$

$$PDEP(I) = LOFEQ/SUM \text{ for } I = 1$$

$$PDEP(I) = ((LOFEQ-I)/SUM) + PDEP(I-1) \text{ for } I = 2 \text{ to } LOFEQ$$

3) Fully depreciated all years.

$$PDEP(I) = 1.0 \text{ for } I = 1 \text{ to } LOFEQ$$

o Non-Discounted Annual Total Investment

$$IEQUIP(I) = CEQUIP(I) + IEQUIP(I) \\ \text{for } I=1, N$$

$$IEQUIP(I) = TAEQC(I) - RVEQ \\ \text{for } I=N$$

o Non Discounted Annual Recurring Cost/Savings

$$REQUIP(I) = MEQUIP(I) \text{ for } I=1, N$$

o Total Non-Discounted Annual Cost/Savings

$$TAEQC(I) = IEQUIP(I) + REQUIP(I)$$

o Discounted Annual Total Costs (Constant Dollars)

$$DISCNT(I) = (2.0 + DRATE)/(2.0*(1.0 + DRATE)**I) \\ \text{for } I=1, N$$

$$DTAEQC(I) = TAEQC(I)*DISCNT(I)$$

o Inflated Annual Total Costs (Current Dollars)

$$INFCAT(I) = (2.0*(1.0+INRATE**I))/(2.0+INRATE)$$

$$ITAEQC(I) = TAEQC(I)*INFCAT(I)$$

o Discounted Inflated Annual Total Costs

$$FTAEQC(I) = ITAEQC(I)*DISCNT(I)$$

o Totals of Annual Costs

$$TEQUC = \sum_{I=1}^N TAEQC(I)$$

$$DTEQC = \sum_{I=1}^N DTAEQC(I)$$

$$\text{ITEQC} = \sum_{I=1}^N \text{ITAEQC}(I)$$

$$\text{FTEQC} = \sum_{I=1}^N \text{FTAECQC}(I)$$

4. Prepare output reports for baseline calculations.
5. Retain Non-Discounted Annual Total Investment IEQUIP*, and Non-Discounted Annual Recurring Cost/Savings, REQUIP* vectors for completion of next sequence of calculations with benefit pattern applied.
6. Setup model to sequence through calculations using input from CMIB file.
7. Read input variables from first Entity Type 2 (Vehicles) record.
8. Perform calculations outlined in Step 3 for new input variables.
9. Print output reports for calculations with benefits applied.
10. Subtract new IEQUIP* and REQUIP* vectors from those retained in Step 5 to determine resultant Investment and Cost/Savings vectors to be written to the CMR file.
11. Repeat sequence 1 through 10 for remaining Type 2 Entities in the CMIA and CMIB files.

Outputs: Outputs from the Vehicle Cost Model program are similar to the outputs of Program P52, Training Cost Model and should include:

1. Input Technical and Cost Factors combined report.
2. Output Technical and Cost Results Combined report.
3. A resultant Investment vector and a resultant Recurring Cost/Savings vector are written to the CMR file for each entity processed.

Program P54 (Job/Task Cost Model).

Purpose: The Job/Task Cost Model calculates the delta cost effect from the innovation benefit pattern associated with a change in job performance. It calculates and combines three major categories of costs; namely, cost of equivalent personnel for both normal performance of the tasks as well as the performance required to recover from certain task error situations, the cost associated with the commission of errors which are non-manpower related, and the costs of support items such as tools, etc., which are required on an annual basis for the performance of the tasks. The objective as was with the previous training cost and vehicles cost models is to create a twenty-year dollar vector. However, since all cost/savings in the Job/Task Model are considered recurring, no investment vector is created. A null investment vector, however, will be written to the CMR file.

Input: The data input variables required to run the Job/Task Cost Model were set up by Program P51. The baseline input variables are contained in the Cost Model's Input W/O Benefits (CMIA) file and would generally reflect the EXJ file unless modified by Program P51. The input variables with benefits applied, as set up by Program P51, are contained in the Cost Model's Input With Benefits (CMIB) file.

The input variables are the same as described in Figure III-8 EXJ DATA ELEMENTS.

Process: The major program process steps are:

1. Set up model to sequence through calculations using input from the CMIA file.
2. Read input variables from first Entity Type 3 (Job/Tasks) record.
3. Calculate:

- o Annual Task Time Without Errors (by Type Person)

```
OFFTT(I) = APERS(I)*TTASK*FTASK*OPTSK
           for I = 1 to N
ENLTT(I) = APERS(I)*ITASK*FTASK*EPTSK
           for I = 1 to N
CIVTT(I) = APERS(I)*TTASK*FTASK*CPTSK
           for I = 1 to N
TOTTT(I) = OFFTT(I) + ENLTT(I) + CIVTT(I)
           for I = 1 to N
```

- o Annual Error Time

```
ERRTT(I) = APERS(I)*TTASK*FTASK*ERTSK
           for I = 1 to N
```

- o Total Annual Task Time (by Type Person)

```
TTOFF(I) = OFFTT(I) + (ERRTT(I)*EPTSK)
           for I = 1 to N
TTENL(I) = ENLTT(I) + (ERRTT(I)*EPTSK)
           for I = 1 to N
TTCIV(I) = CIVTT(I) + (ERRTT(I)*CPTSK)
           for I = 1 to N
TTTOT(I) = TTOFF(I) + TTENL(I) + TTCIV(I)
           for I = 1 to N
```

- o Total Annual Equivalent Persons (by Type Person)

```
EQVOFF(I) = TTOFF(I)/2080
           for I = 1 to N
EQVENL(I) = TTENL(I)/2080
           for I = 1 to N
EQVCIV(I) = TTCIV(I)/2080
           for I = 1 to N
EQVTOT(I) = EQVOFF(I) + EQVENL(I) + EQVCIV(I)
           for I = 1 to N
```

TAEG REPORT NO. 40

o Annual Salary Cost (by Type)

$$\text{OFFSLC}(I) = \text{EQVOFF}(I) * \text{OFFSL}$$

for I = 1 to N

$$\text{ENLSLC}(I) = \text{EQVENL}(I) * \text{ENLSL}$$

for I = 1 to N

$$\text{CIVSLC}(I) = \text{EQVCIV}(I) * \text{CIVSL}$$

for I = 1 to N

$$\text{TOTSLC}(I) = \text{OFFSLC}(I) + \text{ENLSLC}(I) + \text{CIVSLC}(I)$$

for I = 1 to N

o Total Annual Costs (by Type)

$$\text{TOFFC}(I) = \text{OFFSLC}(I) + (\text{OFFTT}(I) / \text{TTASK}) * \text{OERRC} + \text{APERS}(I) * \text{SUPPC} * \text{OPTSK}$$

for I = 1 to N

$$\text{TENLC}(I) = \text{ENLSLC}(I) + (\text{ENLTT}(I) / \text{TTASK}) * \text{OERRC} + \text{APERS}(I) * \text{SUPPC} * \text{EPTSK}$$

for I = 1 to N

$$\text{TCIVC}(I) = \text{CIVSLC}(I) + (\text{CIVTT}(I) / \text{TTASK}) * \text{OERRC} + \text{APERS}(I) * \text{SUPPC} * \text{CPTSK}$$

for I = 1 to N

o Non-Discounted Annual Recurring Cost/Savings

$$\text{TTOTC}(I) = \text{TOFFC}(I) + \text{TENLC}(I) + \text{TCIVC}(I)$$

for I = 1 to N

o Discounted Annual Recurring Cost/Savings (Constant Dollars)

$$\text{DISCNT}(I) = (2.0 + \text{DRATE}) / (2.0 * (1.0 + \text{DRATE}) ** I)$$

for I = 1, N

$$\text{DTTOTC}(I) = \text{TTOTC}(I) * \text{DISCNT}(I)$$

for I = 1, N

o Inflated Annual Recurring Cost/Savings (Current Dollars)

$$\text{INFCAT}(I) = (2.0 * (1.0 + \text{INRATE} ** I)) / (.20 + \text{INRATE})$$

for I = 1, N

$$\text{ITTOTC}(I) = \text{TTOTC}(I) * \text{INFCAT}(I)$$

for I = 1, N

o Discounted Inflated Annual Costs

$$\text{FTTOTC}(I) = \text{ITTOTC}(I) * \text{DISCNT}(I)$$

for I = 1, N

o Totals of Annual Costs

$$\text{TTOC} = \sum_{I=1}^N \text{TTOTC}(I)$$

$$DTC = \sum_{I=1}^N DTTOTC(I)$$

$$ITOC = \sum_{I=1}^N ITTOTC(I)$$

$$FTOC = \sum_{I=1}^N FTTOTC(I)$$

4. Prepare output reports for baseline calculations.
5. Retain non-discounted annual recurring cost/savings, TTOTC* vector for completion of next sequence of calculations with benefit pattern applied.
6. Set up model to sequence through calculations using input from CMIB file.
7. Read input variables from first Entity Type 3 (Job/Tasks) record.
8. Perform calculations outlined in Step 3 for new input variables.
9. Print output reports for calculations with benefits applied.
10. Subtract new TTOTC* vector from the previous one retained in Step 5 to determine resultant Cost/Savings vector to be written to the CMR file. Since no Investment vector was calculated, a null vector will be written to the CMR file for investment.
11. Repeat sequence 1 through 10 for remaining Type 3 Entities in the CMIA and CMIB files.

Outputs: Outputs from the Job/Task Cost Model program are similar to the outputs of Program P52, Training Cost Model, and should include:

1. Input Technical and Cost Factors Combined Report.
2. Output Technical and Cost Results Combined Report.
3. A resultant Recurring Cost/Savings vector and a null Investment vector are written to the CMR file for each entity processed.

Cost Model Summary. Each of the cost models writes a record to the CMR file per the format previously identified for that file. The final step of the Cost Models program should summarize the results for all entities. CMR file Record Type 5 (Pos 1 = 5) will contain the summary of all Courses, Record Type 6 will contain a summary of all Vehicles, and Record Type 7 will contain a record of all Job/Tasks. The total of these three summaries will be added into a Record Type 8. The Record Type 9 of the CMR file will be summarized into by Program P60 after the Risk Package cost for Record Type 4 has been identified.

ETAM RISK REDUCTION. A major aspect of the ETAM process is the evaluation of various alternatives to implementing and gaining user acceptance of the innovation. A number of risk factors with regard to the acceptance of the innovation were previously identified and their profile was stored in the RKP file. An example of this file was previously shown in Figure III-10. As a result of the risks that were identified, a number of risk reduction projects were devised. The projects were targeted at the high risk categories outlined in the RKP file. The RRPJ file contains descriptions of the risk projects. Figure III-11 showed an example of the RRPJ file contents. The assessor can group these projects into up to nine combinations for subsequent evaluation within the Decision Analysis part of the ETAM Assessment function. The objectives of the Risk Reduction function are:

1. Permit the assessor to review risk data stored in the RKP and RRPJ files.
2. Provide the user with the capability of selecting up to nine combinations of the projects stored in the RRPJ file and to retain these groupings in the RRPK file for subsequent access by the Decision Analysis function.
3. Provide the user with access to the program for assigning probabilities of implementation success and user acceptance success to the various risk packages. This is performed by calling Program P59, which will also be accessible to the user under the Decision Analysis function.

These objectives are accomplished through two programs, namely:

P56 - Risk Reduction Project Grouping
P59 - Assign Probabilities

These programs access three Project Data Base files:

RKP which stores a profile of the risks associated with acceptance of the innovation,
RRPJ which stores any of the identified Risk Reduction projects, and
RRPK which will contain the final results of the project groupings as performed by Program P56.

The formats for the data files were previously outlined in the section on the Project Data Base. In this section, the program to support the grouping of the Risk Reduction projects is outlined, namely Program P56. Figure III-42 shows the interrelationships between the Programs P56, P59, and the Executive Control.

Program P56 (Risk Reduction Project Grouping).

Purpose: This program permits the user to review the various descriptive and risk project data and then to group the identified projects into combinations for storage in the RRPK file. The user has the option of inputting probabilities directly to the RRPK file as the Risk Reduction projects are grouped, or of calling the Assign Probabilities Program P59 in order to assist in establishing the probabilities. The user can continue to group Risk Reduction projects until either the QUIT option is selected or a maximum of nine project groupings have been made for storage in the RRPK file.

Inputs: The major inputs to Program P56 are the descriptive data in the RKP and RRPJ files as well as the cost data stored in the RRPJ file associated with each Risk Reduction project. The format of these files has been previously described in the Project Data Base part of this section of the report.

Process: The major program process steps are:

1. Provide access to Program P56 through either the RUNRISK EXEC or the ETAM EXEC, both of which call the RISK EXEC which accesses Program P56.

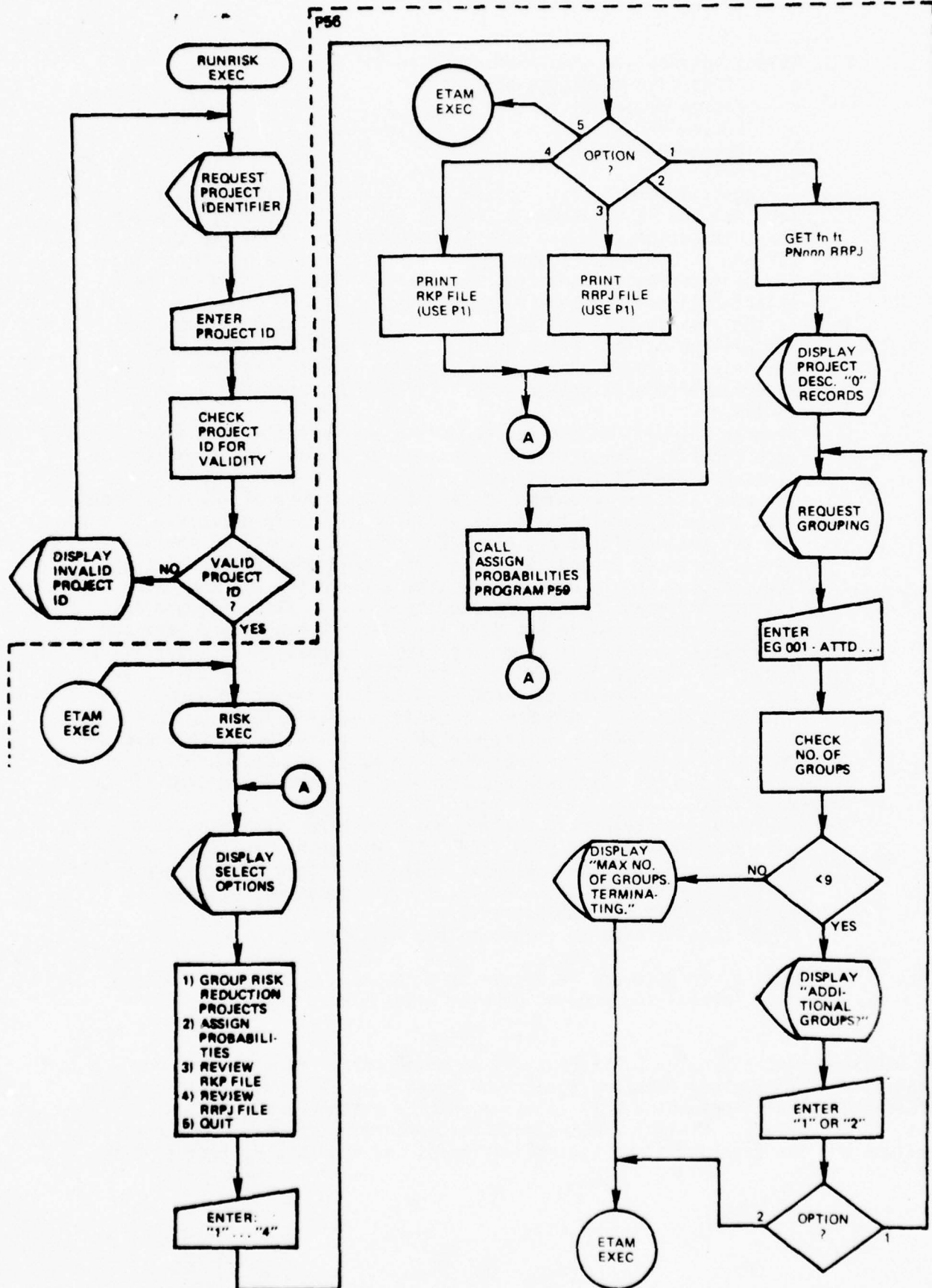

FIGURE III-42. ETAM RISK REDUCTION (RISK) PROCESS FLOW
III-99

TAEG REPORT NO. 40

2. Select options are displayed which permit the user to
 - o Group Risk Reduction projects
 - o Assign probabilities
 - o Review RKP file
 - o Review RRPJ file
 - o Quit
3. The user is permitted to select one of these options from a terminal and is branched to the appropriate processing function for that option. In the case of requests for reviewing the RKP and RRPJ files, Program P1 is called. Following completion of the descriptive listings, the user will be returned to the select options display for another choice.
4. If the user selects the Assign Probabilities option, Program P59 will be called, after which the user will be returned to the select display option. If the user selects the Group Risk Reduction Projects option, the Program P56 processing steps will continue.
5. Program P56 will access the RRPJ file and will list the descriptive zero records. These records contain the project ID, project name, date, and overall project cost.
6. The user is then requested to select one or more of the Risk Reduction projects within the first grouping. This is performed by entering the project ID; e.g., 001-ATTD, 001-SART, etc. If the user wishes to enter probabilities at this time, the last project ID in the grouping should be followed with a slash (/) and then nine two-digit probabilities separated by commas. Also, the project cost which appeared in the RRPJ file descriptive record zero can be entered immediately after the ninth probability. Figure III-12 showed an example of entries in the RRPK file. For example, the entry appearing opposite record 1-0 would be inputted as follows: 001-SART, 002-SART, 003-SART, 004-SART, 001-ATTD/90,95,99,80,85,90,50,60,70,110550000. The project ID's prior to the slash would be placed in record 1-0 of the RRPK file while the probabilities and costs after the slash would appear opposite the 1-1 record of the RRPK file.
7. The number of groups is checked and if greater than nine, the user will be exited to the ETAM EXEC. If less than nine, the user will be requested if additional Risk Reduction project groups are desired. If the user selects this option, another grouping; i.e., group 2 can be entered via the terminal.
8. Final results will be stored in the RRPK file.

Outputs: The output of Program P56 is one or more records to be stored in the RRPK file identifying project groups, associated probabilities, and cost.

ETAM DECISION ANALYSIS. The DTREE routines sequence and/or permits assessor selection of the programs required to develop decision tree input factors and to perform the calculations which will allow generation of the ETAM DECISION ANALYSIS DETAIL REPORT (DT01). Minimal requirements for performing the decision tree calculations are the development of outcome utilities and node probabilities. The

Decision Analysis report DT01 will be generated if 1) probabilities exist in the number 0 record (NO RISK PKG) of the RRPK file, and 2) outcome utilities exist in the number 999 record of the VARF file. If new or additional probabilities are to be developed, P59 is called to prompt the assessor in specifying probabilities. If new or modified outcomes are to be developed, P58 is called to permit the assessor to 1) select new relevant variables from the VQAL project file, and 2) to prompt the assessor in the process sequence for assigning values to the selected variables. Several display formats guide the assessor in developing and validating the decision tree outcomes. Figure III-43 shows the process flow for the Decision Analysis routines within the ETAM Assessment function.

The basic methodology in performing the ETAM Decision Analysis centers around the decision tree which is shown in Figure III-44. Each alternative path in the tree leads to an outcome value (A, B, C & D) which incorporates both quantitative Cost Model Results (from CMR project file) and equivalent dollar (utility) values for relevant qualitative factors. Probabilities that an outcome will occur are estimated at PX & PW). The probability estimates are developed and stored in the variable reference (VARF project file). Risk patterns which reduce the success probabilities can be moderated by undertaking Risk Reduction Projects (RRPJ project file) which have been grouped into Risk Reduction Packages (RRPK project file). The decision tree provides for up to nine (9) Risk Reduction Packages with their associated costs (COST-COST9) and modified success probabilities (PX1-PX9, PW1-PW9). The probability of Risk Reduction Project success can also be estimated (PI1-PI9). There are outcome probabilities (PZ1-PZ9 & PY1-PY9) associated with the failure of the projects which are also estimated.

Considering this decision analysis framework, the major objectives in performing the decision analysis are to:

1. Develop values for the four major potential outcomes resulting from the assessment of the innovation; i.e., A) acceptance, successful implementation, user acceptance; B) acceptance, successful implementation, user non-acceptance; C) acceptance, inability to implement; and D) rejection.
2. Estimate probabilities for each of the potential outcomes.
3. Develop an accept/reject decision variable based on the outcome values and the probabilities of their occurrence.
4. Introduce various combinations of risk reduction packages into the decision process, considering their costs and effects upon the success probabilities of the outcomes.

The first objective is accomplished by taking the quantitative results of applying the appropriate cost model to the benefit pattern, and developing equivalent values for each of the identified qualitative variables which are stored in the VQAL project file. A relative importance factor is identified for the cost/savings variable as well as each of the qualitative variables. A value can then be developed for each outcome which considers the independent value of each variable and its relative importance. The outcome scenarios previously developed and stored in the SCEN project file are reviewed by the assessor during this variation process.

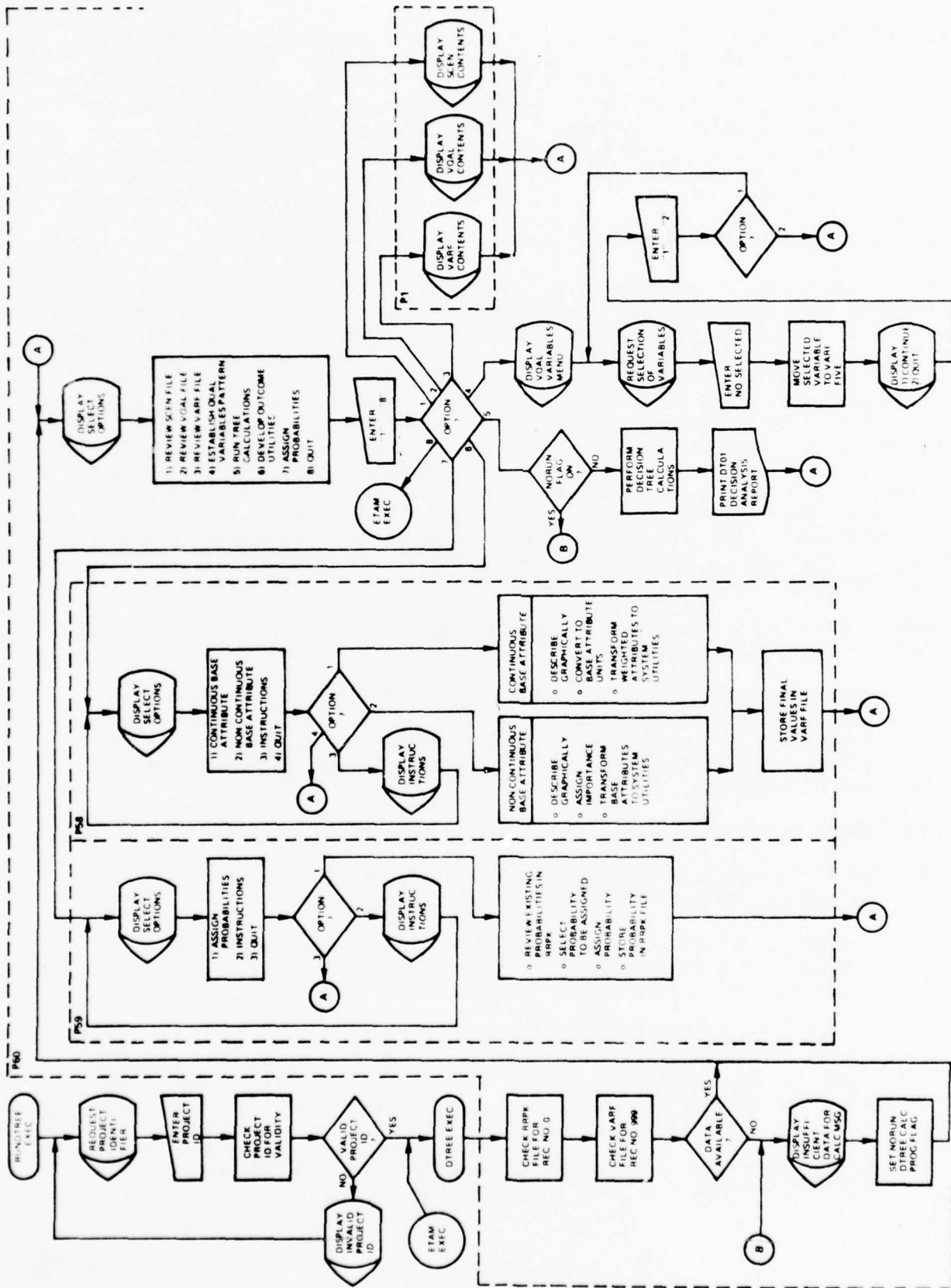

FIGURE III-43. ETAM DECISION ANALYSIS (DTREE) PROCESS FLOW:

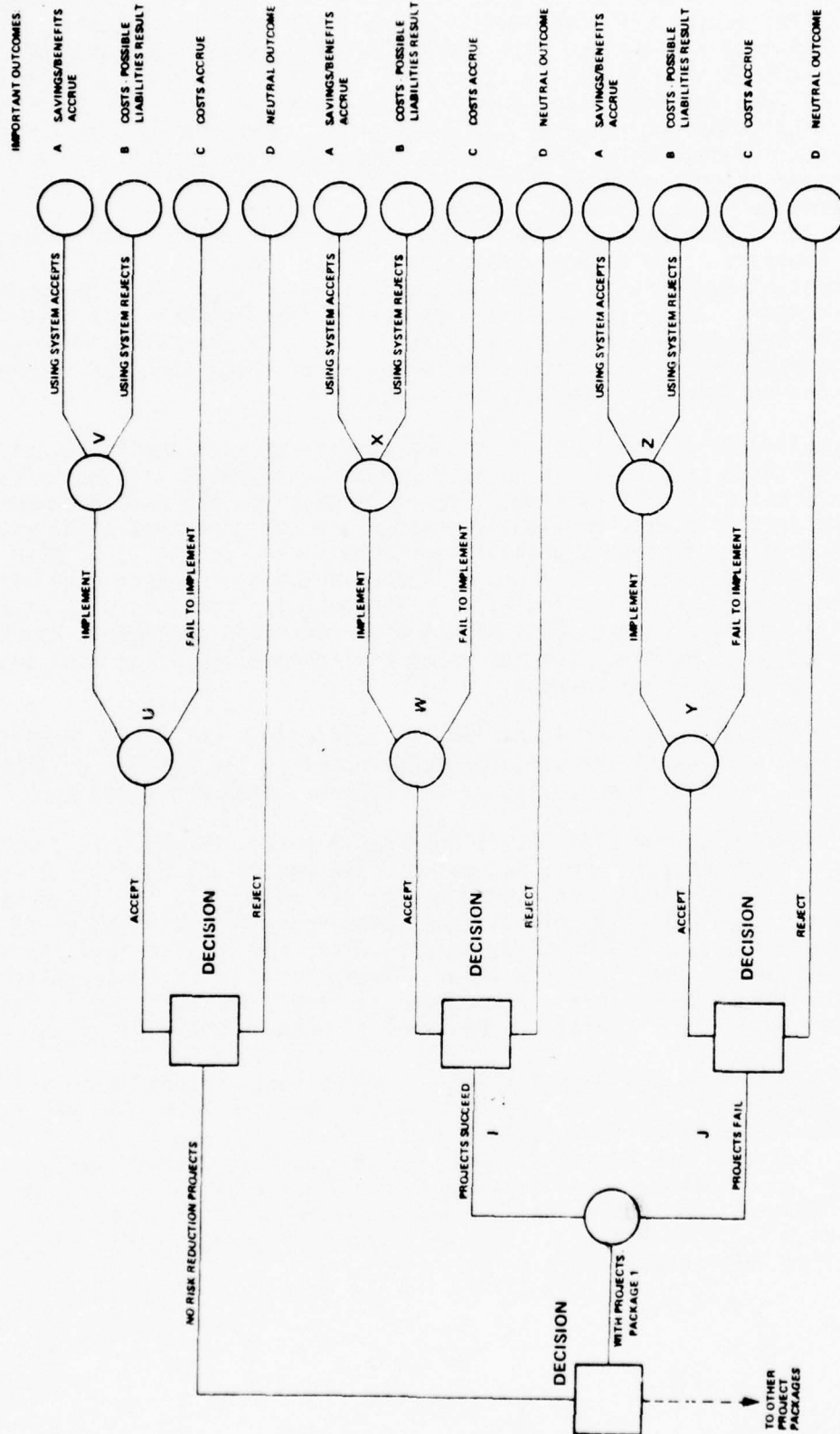

FIGURE III-44. DECISION TREE FOR ASSESSMENT OF TRAINING INNOVATION

The second objective is achieved by considering the various risks in implementation and in user acceptance which were previously identified descriptively in the RKP, Risk Profile summary project file. An initial set of probabilities was developed at the time the various risk reduction projects were grouped, since it was necessary at that time to modify those probabilities considering the effects of the projects upon implementation success and user acceptance. At this time the probabilities should be reviewed and modified if appropriate. The third objective is accomplished by calculating the expected value of the accept path using the outcome values and probabilities. Since a reject decision has a zero value, any positive expected value on the accept decision leg would generally indicate that the innovation has benefit and should be accepted. The calculation of a number, however, is no panacea for the difficult decision process which requires a constant examination of all assumptions which went into the derivation of the final number. Also, it should be remembered that the decision rule for calculating the decision variable was expected value. If the decision maker intends to apply another rule, such as minimization of risk, then the result will have to be reexamined in that light.

The final objective is to modify the decision components with the introduction of projects, which at some cost can improve the success probability of introducing the innovation into the system. The risk reduction projects documented in the RRPJ project file were previously grouped and the groupings along with their effects upon the success probabilities, were stored in the RRPK, Risk Reduction Packages project file. A new decision variable, for each path with a risk reduction package, can be calculated. The decision variable will have been calculated considering the costs of the risk reduction packages. Now the path with the highest positive expected value will generally be the most acceptable, subject to the previous caveats.

Several display formats are used in aiding the assessor in estimating magnitudes and importance weightings of the variables considered in the outcome utility. Additional reports present the results of the ETAM Decision Analysis process.

This section begins with the ETAM DECISION ANALYSIS DETAIL REPORT (DT01) which describes the inputs, calculations, and outputs related to the decision tree structure previously outlined. Following the detail report are the major selective interpretive, logical, and calculational sequences for the assessor to assign values and importance weightings to variables, and to associate probabilities with the various decision tree paths. These functions are accomplished by Program P58 and P59, respectively. Program P60 controls the Decision Analysis sequence and performs the calculations required to produce the DT01 Report.

ETAM Decision Analysis Detail Report (DT01). The following identifies data sources and calculational logic for generating the fields on the ETAM DECISION ANALYSIS DETAIL REPORT which is produced by Program P60. Fields outlined on the report layout not described here are fixed, and are generated by the program format statements. A sample report showing data elements by column/row coordinate is shown in Figure III-45. Up to three reports may be required if the total of nine maximum risk reduction packages is used. The NO RISK PKG column of data elements is repeated on each report.

EDUCATIONAL TECHNOLOGY ASSESSMENT MODEL REPORT FORM REPORT DT01

0000000011111111222222223333333344444444555555566666667777777788
 1234567890123456789012345678901234567890123456789012345678901234567890

COL00000000000000000011111111222222222233333333444444445555555666666677777778888888899999999

ETAM DECISION ANALYSIS DETAIL REPORT * OF *

A	B	C	D	E	F	G	H	J	K	L	M	N	P	Q	R	S	T	U	V	W	X	Y	Z
VARIABLE DESCRIPTION																							
RANK OF ALTERNATIVE	-	-	-	-	-	-	-	-	-	-	-	-	-	-	-	-	-	-	-	-	-	-	
UTILITY OF OUTCOME A	(***)	(***)	(***)	(***)	(***)	(***)	(***)	(***)	(***)	(***)	(***)	(***)	(***)	(***)	(***)	(***)	(***)	(***)	(***)	(***)	(***)	(***)	
UTILITY OF OUTCOME B	(***)	(***)	(***)	(***)	(***)	(***)	(***)	(***)	(***)	(***)	(***)	(***)	(***)	(***)	(***)	(***)	(***)	(***)	(***)	(***)	(***)	(***)	
PROBABILITIES X AND Z	(***)	(***)	(***)	(***)	(***)	(***)	(***)	(***)	(***)	(***)	(***)	(***)	(***)	(***)	(***)	(***)	(***)	(***)	(***)	(***)	(***)	(***)	
VALUE X (USER/PSUCC)	(***)	(***)	(***)	(***)	(***)	(***)	(***)	(***)	(***)	(***)	(***)	(***)	(***)	(***)	(***)	(***)	(***)	(***)	(***)	(***)	(***)	(***)	
VALUE Z (USER/PFAIL)	(***)	(***)	(***)	(***)	(***)	(***)	(***)	(***)	(***)	(***)	(***)	(***)	(***)	(***)	(***)	(***)	(***)	(***)	(***)	(***)	(***)	(***)	
UTILITY OF OUTCOME C	(***)	(***)	(***)	(***)	(***)	(***)	(***)	(***)	(***)	(***)	(***)	(***)	(***)	(***)	(***)	(***)	(***)	(***)	(***)	(***)	(***)	(***)	
PROBABILITIES W AND Y	(***)	(***)	(***)	(***)	(***)	(***)	(***)	(***)	(***)	(***)	(***)	(***)	(***)	(***)	(***)	(***)	(***)	(***)	(***)	(***)	(***)	(***)	
VALUE W (IMPL/PSUCC)	(***)	(***)	(***)	(***)	(***)	(***)	(***)	(***)	(***)	(***)	(***)	(***)	(***)	(***)	(***)	(***)	(***)	(***)	(***)	(***)	(***)	(***)	
VALUE Y (IMPL/PFAIL)	(***)	(***)	(***)	(***)	(***)	(***)	(***)	(***)	(***)	(***)	(***)	(***)	(***)	(***)	(***)	(***)	(***)	(***)	(***)	(***)	(***)	(***)	
UTILITY OF OUTCOME D	(***)	(***)	(***)	(***)	(***)	(***)	(***)	(***)	(***)	(***)	(***)	(***)	(***)	(***)	(***)	(***)	(***)	(***)	(***)	(***)	(***)	(***)	
VALUE OF PSUCC PATH	(***)	(***)	(***)	(***)	(***)	(***)	(***)	(***)	(***)	(***)	(***)	(***)	(***)	(***)	(***)	(***)	(***)	(***)	(***)	(***)	(***)	(***)	
VALUE OF PFAIL PATH	(***)	(***)	(***)	(***)	(***)	(***)	(***)	(***)	(***)	(***)	(***)	(***)	(***)	(***)	(***)	(***)	(***)	(***)	(***)	(***)	(***)	(***)	
PROB OF PROJ SUCCESS	(***)	(***)	(***)	(***)	(***)	(***)	(***)	(***)	(***)	(***)	(***)	(***)	(***)	(***)	(***)	(***)	(***)	(***)	(***)	(***)	(***)	(***)	
VALUE BEFORE RISK PKG	(***)	(***)	(***)	(***)	(***)	(***)	(***)	(***)	(***)	(***)	(***)	(***)	(***)	(***)	(***)	(***)	(***)	(***)	(***)	(***)	(***)	(***)	
COST OF RISK PACKAGE	(***)	(***)	(***)	(***)	(***)	(***)	(***)	(***)	(***)	(***)	(***)	(***)	(***)	(***)	(***)	(***)	(***)	(***)	(***)	(***)	(***)	(***)	
VALUE OF DECISION VAR	(***)	(***)	(***)	(***)	(***)	(***)	(***)	(***)	(***)	(***)	(***)	(***)	(***)	(***)	(***)	(***)	(***)	(***)	(***)	(***)	(***)	(***)	
0000000011111111222222223333333344444444555555566666667777777888888899999999																							
1234567890123456789012345678901234567890123456789012345678901234567890123456789012345678901234567890																							

FIGURE III-45. ETAM DECISION ANALYSIS DETAIL REPORT (DT01)

TAEG REPORT NO. 40

<u>COL/ROW</u>	<u>VARIABLE</u>	<u>DATA SOURCE AND/OR CALCULATIONAL LOGIC</u>
1B	- DATE	This field is generated within the system and developed as MM/DD/YY.
2B	- RPTNO	This field contains the number of the report being printed (1, 2 or 3).
3B	- NORPTS	This field gives the total number of DT01 reports that are generated. With 0-3 risk pages, this will be 1, 4-6 will be 2, and 7-9 will be 3.
2D	- RPKPGX	This field contains the risk package number for which the evaluation below it is made. On Report 1 these values will be 1, 2 and 3; on Report 2 they will be 4, 5 and 6, and on Report 3 they will be 7, 8 and 9.
3D	- RPKPGY	
4D	- RPKPGZ	
1E	- RANKA	This field will contain a number between 1 and 0, where a 1 indicates the highest ranked alternative; i.e., the Value of the Decision Variable (in Row Z) which is the most positive, and a 0 indicates the lowest ranked alternative. Interim values 2 through 9 will be assigned accordingly. In cases where equal values of the decision variable exist, available numbers will be sequenced from left to right.
2E	- RANKB	
3E	- RANKC	
4E	- RANKD	
1F	- OUTCMA	These fields contain the summation of the outcomes, weighted variable equivalent dollar values which are stored in the number 999 record of the VARF project file.
2F	- OUTCMA	
3F	- OUTCMA	
4F	- OUTCMA	
1G	- OUTCMB	These files contain the Outcome B variable equivalent dollar total from the VARF project file (See 1F-4F description).
2G	- OUTCMB	
3G	- OUTCMB	
4G	- OUTCMB	
1H	- PX+'NA'	This field contains the decision tree probability at the X node for the condition where the innovation is accepted without need to undertake any risk reduction projects. It is developed interactively (or entered in batch) and stored in the number 0 record of the RRPK project file. Since no projects are considered in this decision path, the second probability (P2) is not applicable which is indicated by the NA.
2H	- PXA+PZA	This field contains the probabilities at the X1-X9 and Z1-Z9 nodes which reflect incorporation of risk reduction projects into the decision process. PXA will contain the value of PX1, PX4, or PX7 depending
3H	- PXB+PZB	
4H	- PXC+PZC	

TAEG REPORT NO. 40

upon the Report Number (2B-RPTNO) being generated (PXB will be PX2, PX5 or PX8, and PXC will be PX3, PX6 or PX9). PZA will contain the value of PZ1, PZ4, or PZ7, also depending upon the report number (PZB will be PZ2, PZ5, or PZ8, and PZC will be PZ3, PZ6 or PZ9). These values are stored in number 1 through 9 records (reflecting data on Risk Packages 1 through 9 respectively) of the RRPK project file.

- 1J - X This is the expected value at the X, X1, X2 . . . X9 nodes of the decision tree. XA will reflect X1, X4, or X7 depending upon the report number (XB will be X2, X5 or X8 and XC will be X3, X6, or X9). The value is calculated as:
- $$X_n = (P_{Xn} * OUTCMA + (1 - P_{Xn}) * OUTCMB)$$
- where n is blank, 1, 2, . . . , 9.
- 1K - 'NA' No path exists for the NO RISK PKG situation, therefore, this field is identified as not applicable (NA).
- 2K - ZA This is the expected value at the Z1, Z2, . . . , Z9 nodes of the decision tree. ZA will reflect Z1, Z4, or Z7 depending upon the report number. (ZB will be Z2, Z5 or Z8, and ZC will be Z3, Z6, or Z9). The value is calculated as:
- $$Z_n = (P_{Zn} * OUTCMA + (1 - P_{Zn}) * OUTCMB)$$
- where n is 1, 2, . . . , 9.
- 1M - OUTCMC These fields contain the Outcome C variable equivalent dollar total from the VARF project file (See 1F-4F description).
- 2M - OUTCMC
- 3M - OUTCMC
- 4M - OUTCMC
- 1N - PW+'NA' This field contains the decision tree probability at the W node for the condition where the innovation is accepted without need to undertake any risk reduction projects. It is developed interactively (or entered in batch) and stored in the number 0 record of the RRPK project file. Since no projects are considered in this decision path, the second probability (PY) is not applicable as indicated by the NA.
- 2N - PWA+PYA This field contains the probabilities at the W1-W9 and Y1-Y9 nodes which reflect incorporation of risk reduction projects into the decision process. PWA will contain the value of PW1, PW4, or PW7 depending upon the report number (PWB will be PW2, PW5, or PW8, and PWC will be PW3, PW6, or PW9). PYA will contain the value of PY1, PY4, or PY7, also depending upon the report number (PYB will be PY2, PY5, or PY3, and PYC will be PY3, PY6, or PY9). These values are stored in number 1 through 9 records of the RRPK project file.
- 3N - PWB+PYB
- 4N - PWC+PYC

TAEG REPORT NO. 40

1P - W This is the expected value at W, W1, W2, . . . , W9 nodes
 2P - WA of the decision tree. WA will reflect W1, W4, or W7
 3P - WB depending upon the report number (WB will be W2, W5, or
 4P - WC W8, and WC will be W3, W6, or W9). The value is calculated
 as:

$$W_n = (P_{Wn} * X_n + (1 - P_{Wn}) * OUTCMC)$$

where n is blank, 1, 2, . . . , 9.

1Q - 'NA' No path exists for the NORISK PKG situation, therefore,
 this field is identified as not applicable (NA).

2Q - YA This is the expected value at the Y1, Y2, . . . , Y9
 3Q - YB nodes of the decision tree. YA will reflect Y1, Y4, or
 4Q - YC Y7 depending upon the report number (YB will be Y2, Y5,
 or Y8, and YC will be Y3, Y6, or Y9). The value is
 calculated as:

$$Y_n = (P_{Yn} * Z_n + (1 - P_{Yn}) * OUTCMC)$$

where n is 1, 2, . . . , 9.

1S - OUTCMD These fields contain the Outcome D variable equivalent
 2S - OUTCMD dollar total from the VARF project file. (See 1F-4F
 3S - OUTCMD description). This field will generally be all zeros
 4S - OUTCMD since there should neither be benefits nor liabilities
 associated with the reject path.

1T - DECO These fields will contain the decision variable prior
 2T - PSUCCA to subtracting out the Risk Reduction Package costs. In
 3T - PSUCCB the case of the NO RISK PKG leg, the value of the final
 4T - PSUCCC decision variable (DECO) is printed so it can be compared
 with the same factor for the risk package paths. PSUCCA
 will contain PSUCC1, PSUCC4, or PSUCC7, depending upon
 the report number (PSUCCB will be PSUCC2, PSUCC5, or
 PSUCC8, and PSUCCC will be PSUCC3, PSUCC6, or PSUCC9).
 The value is determined by taking the more positive of Wn
 or OUTCMD (generally zero).

1U - 'NA' No path exists for the NO RISK PKG situation, therefore,
 this field is identified as not applicable (NA).

2U - PFAILA These fields will contain the decision variable prior
 3U - PFAILB to subtracting out the Risk Reduction Package costs.
 4U - PFAILC PFAILA will contain PFAIL1, PFAIL4, or PFAIL7 depending
 upon the report number (PFAILB will be PFAIL2, PFAIL5, or
 PFAIL8, and PFAILC will be PFAIL3, PFAIL6, or PFAIL9).
 The value is determined by taking the more positive
 of Yn or OUTCMD (generally zero).

1V - 'NA' Probability of project success is not applicable to the
 NO RISK PKG path, therefore it is shown as not applicable
 (NA).

TAEG REPORT NO. 40

2V - PIA
 3V - PIB
 4V - PIC

This field contains the probabilities that the Risk Reduction Package in that decision path will be successfully completed. PIA will contain the value of PI1, PI4, or PI7 depending upon the report number (PIB will contain PI2, PI5, or PI8, and PIC will contain PI3, PI6, or PI9). These values are stored in number 1 through 9 records of the RRPK project file.

1W - 'NA'

The value of the risk package is not applicable in the NO RISK PKG path, therefore it is shown as NA.

2W - RKPKGA
 3W - RKPKGB
 4W - RKPKGC

This is the expected value of the decision tree paths to which Risk Reduction Packages have been applied. RKPKGA will contain RKPKG1, RKPKG4, or RKPKG7 depending upon the report number. (RKPKGB will be RKPKG2, RKPKG5, or RKPKG8, and RKPKGC will be RKPKG3, RKPKG6, or RKPKG9). The value is calculated as:

$$RKPKGn = (PIn * PSUCCn + (1 - PIn) * PFAILn)$$

where n is 1, 2, . . . , 9.

1X - 'NA'

The cost of the Risk Reduction Package is not applicable to the NO RISK PKG path, therefore it is shown as NA.

2X - COSTA
 3X - COSTB
 4X - COSTC

These fields contain the value of the Risk Reduction Package in that particular decision tree path. At the time the risk projects were grouped and identified in the RRPK project file, their individual costs were added and stored in that file. COSTA will contain COST1, COST4, or COST7 depending upon the report number (COSTB will be COST2, COST5, or COST8 and COSTC will be COST3, COST6, or COST9). The respective record number in the RRPK project file should be accessed to obtain this value. When the Decision Analysis has been completed and the decision path selected, the respective COSTn value in that path will be stored in the CMR project file (Type 4 record) for input to the Financial Analysis routine.

1Z - DECO
 2Z - DECA
 3Z - DECB
 4Z - DECC

These fields contain the final value on the decision variable for the respective decision path. DECO will have the same value previously determined in 1T. DECA contain DEC1, DEC4, or DEC7 depending upon the report number (DECB will be DEC2, DEC5, or DEC8, and DECC will be DEC3, DEC6, or DEC9). This value is calculated as:

$$DECn = RKPKGn - COSTn$$

where n is 1, 2, . . . , 9.

TAEG REPORT NO. 40

DT01 Variable List Summary.

<u>VAR NAME</u>	<u>I/O</u>	<u>SOURCE/DESTINATION</u>	<u>REPORT REF</u>
DATE	0	INT GEN/TRER + RPT	1B
RPTNO	0	INT GEN/RPT	2B
NORPTS	0	INT GEN/RPT	3B
RKPKGX-Z	0	INT GEN/TRER + RPT	2D-4D
RANKA-D	0	CALC/TRER + RPT	1E-4E
OUTCMA-D	I	VARF/TRER + RPT	1F-4F, 1G-4G, 1M-4M, 1S-4S
PXB-9	I	RRPK/TRER + RPT	1H-4H
PZ1-9	I	RRPK/TRER + RPT	2H-4H
XB-9	0	CALC/TRER + RPT	1S-4S
Z1-9	0	CALC/TRER + RPT	2K-4K
PWB-9	I	RRPK/TRER + RPT	1N-4N
PY1-9	I	RRPK/TRER + RPT	2N-4N
WB-9	0	CALC/TRER + RPT	1P-4P
Y1-9	0	CALC/TRER + RPT	2Q-4Q
PSUCC1-9	0	CALC/TRER + RPT	2T-4T
PFAIL1-9	0	CALC/TRER + RPT	2U-4U
PI1-9	I	RRPK/TRER + RPT	2V-4V
RKPKG1-9	0	CALC/TRER + RPT	2W-4W
COST1-9	I	RRPK/CMR + RPT	2X-4X
DECO-9	0	CALC/TRER + RPT	1T, 1Z-4Z

Program P58 (ETAM Variable Scaling Program).

Purpose: The objective of this program is to develop a system utility for each Decision Tree outcome, based upon a summation of the weighted value of each relevant attribute which is affected by the introduction of the innovation into the system. The assessor will be provided interactive capability in assigning attribute values. Prompting techniques will improve the validity of the overall measure of utility developed for each potential decision outcome. The first step in the process will be to graphically characterize the variables associated with each outcome state. In order to perform this task, the assessor must have a sound understanding of the organizational goals into which the proposed innovation is planned to be introduced. Following the graphic characterization of the variables and outcome states, the assessor will select either the path which treats non-continuous base attributes or the path which handles continuous base attributes. A procedure is presented for development of variable values under each of these conditions. Certain consistency checks can be made in order to improve the validity of the utilities which the assessor derived.

Inputs: The program inputs and sources are:

1. Terminal displayed options which the assessor selects, namely:
 - o Continuous base attribute
 - o Non-continuous base attribute
 - o Instructions
 - o Quit
2. The assessor should have access the scenarios stored in the SCEN file of the Project Data Base. A printout of that file was selectable under Program P60.
3. The relevant qualitative variables which are affected by introducing the innovation into the system were stored in the VQAL file and interactively transferred to the VARF file under Program P60. Thus all of the variables associated with the Decision Tree outcome states, should now be contained in the VARF file.
4. The Cost/Savings stream over the planning period being considered for the innovation will have been stored in the CMR file as a result of one or more cost model runs. A Record Type 9 will have summary information of the project cost and savings.
5. User interaction based upon terminal prompting will provide the inputs necessary to converge on the system utility for each of the outcome states.

Process: The major program process steps are:

1. The Program P58 is called by Program P60 if the user selects the DEVELOP OUTCOME UTILITIES (OPTION 6).
2. A display of the select options is presented to the assessor. The assessor selects either the continuous base attribute option, or the non-continuous base attribute option. The option exists also for printing instructions in which case a series of instructions will be printed and the assessor will then again be displayed the options for another selection. The assessor can also QUIT, in which case the program returns to the major select options under Program P60.

3. Under either of the selected options the assessor will prepare a descriptive (graphical) representation of the attributes.
4. This step more or less extends the characterization of the outcome states as outlined in the SCEN file. Its purpose is to prompt a continued orientation to the operational meaning inherent in the selected relevant attributes. If this step does not cause the qualitative variables to be anchored in some operational context, then in all probability the variables should be eliminated from consideration.

It is important, at this point, that the assessor have a sound understanding of the goals of the organization into which the proposed innovation would be introduced. For each attribute impacted by the innovation, the assessor should be able to identify some organizational goal to which it can be related. The prior emphasis upon an operational and organizational context for each qualitative attribute should now be apparent. The assessor will attempt to describe the change to or away from some goal-state which occurs from introducing the innovation. Estimates will then be made for the states of each of the other potential outcomes. Figure III-46 provides a sample result of the estimation process. Attribute x_1 (On-Job Flexibility) is estimated at its present state (x_1^p) which is the state assuming the innovation is rejected. The assessor believes that this present state is about halfway (50%) between what is considered barely tolerable and what is considered ideal. Next, the assessor considers the effect of the innovation on this variable, if the innovation is successful (Outcome A). This situation is estimated to improve the state of the On-Job Flexibility from its present state (50%) to a point about halfway to the ideal state. This is shown as x_1^i which is at the 75% point. Intermediate outcomes (B and C) are then estimated. This same process is performed for the remaining attributes (x_2 , x_3 and x_4).

The preceding approach called for direct estimates of the outcome points by attribute. There are several other techniques which may be applied both here, and in a later step dealing with importance estimates. One or more of these alternate methods should be considered as a test for consistency (reliability) of the values estimated.

- 1) Ratio tests over range x_1^t to x_1^g . Considering the x_1 attribute shown in Figure III-46, test the reasonability of the ratios of each outcome level to the goal and tolerable states. For example:
 - a) Is the present state (D) just as far away from the ideal as it is from the least tolerable state.
 - b) Does satisfactory introduction of the innovation (Outcome A) accomplish 50 percent of what is expected in order to achieve the goal state (x_1^g).

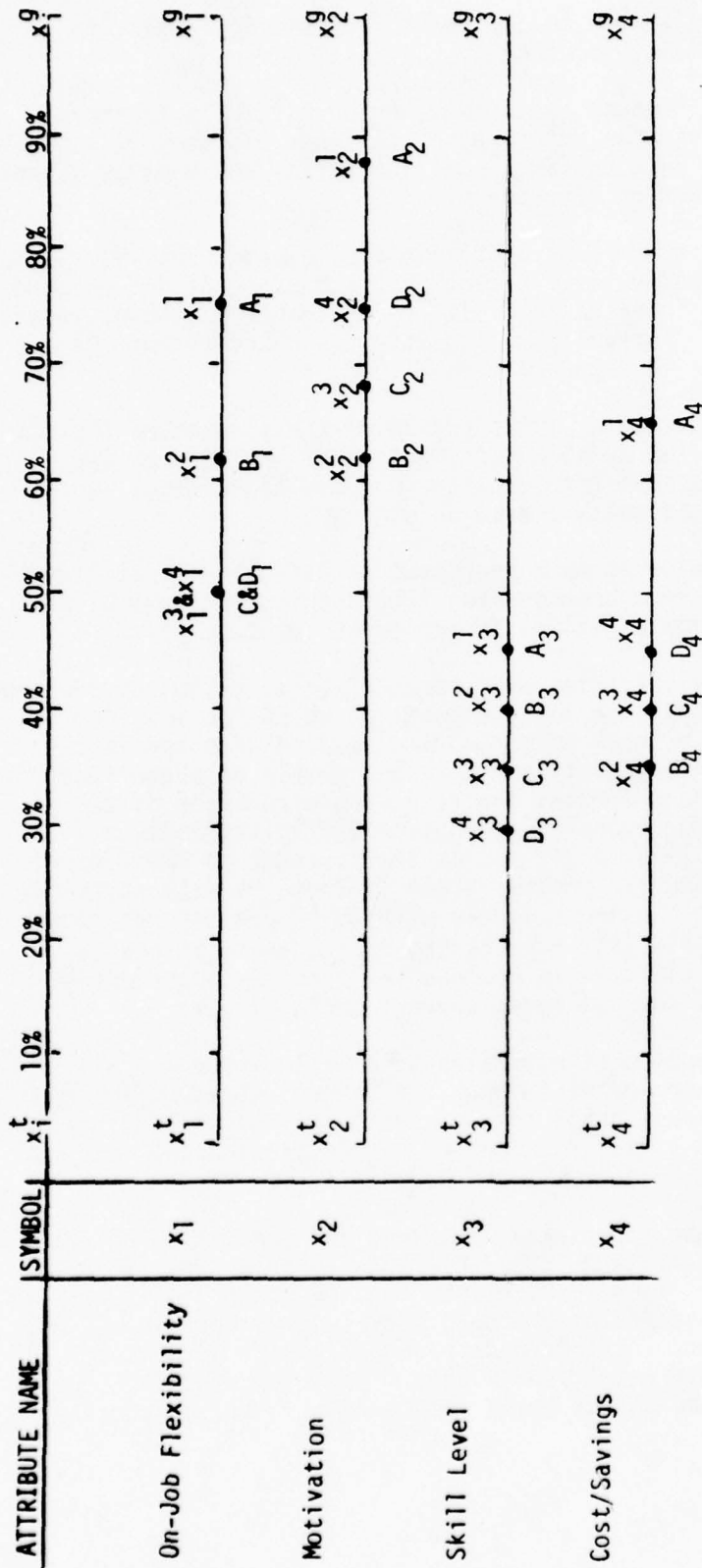

FIGURE III-46. GRAPHICAL REPRESENTATION OF OUTCOME STATES BY ATTRIBUTE IN RELATION TO LEAST TOLERABLE AND GOAL STATES

TAEG REPORT NO. 40

- c) Does a failure to implement (Outcome C) result in essentially no change.
 - d) If the innovation is implemented but fails to improve the system as anticipated, (Outcome B), does it contribute 50% as much toward accomplishment of the goal as successful introduction (Outcome A).
- 2) Ratio tests over range of possible outcomes. This is similar to the preceding test, except that the ratio of one outcome to another, independent of its relationship to the extremes, is checked. For example, consider the outcomes for the attribute x_2 in Figure III-46.
- a) Does successful introduction of the innovation (Outcome A) provide as much satisfaction or utility, as the unsuccessful introduction (Outcome B) reflects in decreased satisfaction or utility.
 - b) Does twice as much decreased satisfaction or utility result from unsuccessful introduction (Outcome B) as does from a failure to implement (Outcome C).
- 3) Indifference-lotteries over range x_1^t to x_1^g . The indifference-lottery method look for the point at which the assessor is indifferent between accepting the results of a specific outcome with certainty and taking a gamble at prescribed odds with the potential for receiving either one of two outcomes. For example, again considering attribute x_1 in Figure III-46, would you as the assessor be indifferent to maintaining the present state (Outcome D) with certainty, as opposed to taking a gamble with 50:50 odds of reaching the ideal state (x_1^g) or dropping to the least tolerable state (x_1^t). If this is reasonable, then the placement of Outcome D at the 50% level appears correct.

The preceding sequence of estimates will be prompted for via the terminal. The assessor will input the values requested which will be temporarily stored until the completion of the utility scaling process. At that time, an output report displaying the outcome states by scaled variable (Report DT02) will be printed.

5. If there exists one relatively important and quantified benefit variable, such as dollars, then this path through Steps 5 and 6 will be followed. Each level of each of the other attributes can be converted into units of the base attribute by applying a tradeoff procedure. The graphical representation of outcome states by attribute developed in Step 4 and presented in Figure III-46 will be used as the basic reference for this conversion process.

For example, in Figure III-46, consider that the dollars (cost/savings variable x_4) saved as a result of successfully introducing an innovation are a dominant aspect of the decision-making process. A specific dollar cost or savings will have been obtained as a result of the cost model processing of the outcome scenario parameters previously created. Assume Outcome A produces a savings of \$500,000 (500K) and Outcomes C and B result in losses or costs of 100K and 200K, respectively. Outcome D where the innovation has been rejected is neutral, or zero cost/savings. The dollar variable, then, has a relatively wide range of outcome possibilities, and is also significant in terms of the values taken on across the potential outcomes. The dollar dimension is therefore selected as the continuous base attribute into which the levels or states of each of the other attributes will be converted.

Consider the attribute, On-Job Flexibility, (x_1 in Figure III-46). Outcome A appears to have a substantial positive value in that it has the effect of moving the organization half-way to its ideal or goal-state (from a present state of 50 percent, to 75 percent). The question can be asked: "How many dollars of the organization's budget would the decision maker be willing to invest to avoid losing about the same level of On-Job Flexibility as results from successful introduction of the innovation?" The question should be answered independent of the range of cost/savings possibilities related to the innovation decision. If the answer were 50K dollars, then this represents additional value (over and above the 500K savings) to Outcome A. This same process is repeated for the remaining states of variable x_1 , as well as for each state of the variables x_2 and x_3 . Where an outcome is less than the neutral state (as with Outcomes B and C for x_2), then the appropriate question to be asked by the assessor would be: "How many dollars of the organization's budget would a decision maker be willing to pay to avoid the decreased level of the attribute resulting from a decision (and potential outcome from the decision) regarding the innovation?" The results of such a tradeoff analysis is tabulated, for example, as follows:

		<u>ATTRIBUTE</u>			
		$\$(x_4)$	Skill(x_3)	Motiv(x_2)	On-Job Flex(x_1)
O U T C O M E	A	+500K	+30K	+10K	+20K
	B	-200K	+20K	-10K	+10K
	C	-100K	+10K	-5K	0
	D	0	0	0	0

Intermediary verbal descriptions for each level would undoubtedly be used in arriving at these types of value estimates (e.g., significant increase in skill level). These should come about through the analysis from Step 4.

The output of this step will be defined in the output section of this program and will be displayed to the user in the report on variable values by outcome (DT04).

6. As a result of the previous step, each level or state of all relevant attributes was converted into a value reflected in the same units as those of a selected important continuous base variable such as dollars. If the organization or system utility for units of the base dimension is linear, i.e., 200K dollars is preferred exactly twice as much as 100K dollars, then the values identified for each outcome state can be summed across Outcome A, then Outcome B, etc. For example, the value of Outcome A would be the sum of 500K dollars, 30K dollars worth of skill level, 10K dollars worth of motivation, and 20K dollars worth of on-job flexibility; it would be 560K dollars.

In many cases the organization or system utility for dollars will not be linear. The initial 100K dollar savings may be worth much more than another 100K (200K total) because it has greater utility in any application the organization has for dollars. This should be clear if the first 100K could be invested in a machine that would double capacity, increase profits, and produce a 100 percent return-on-investment; while the second 100K has a utility ten times that of the second 100K. This may be an extreme example, but it should make the point.

The problem, therefore, in this step is to insure that the utility ultimately determined at some particular outcome reflects the sum of the utilities for each of the attributes estimated at this state. An important assumption in this process is that when a tradeoff estimate is made for some attribute state in units of the continuous base variable, not in terms of its actual value. For example, when the system through the action of the decision maker is willing to commit (as is expected when the tradeoff value is decided upon) 30K dollars to achieve some X units worth of increased skill level, that committed amount takes into account the utility that 30K dollars has to the system. Therefore the 10K dollars estimated for an increased level of motivation would have one-third the utility of the 30K only if the system preference for each 10K increment were equal. Thus, before the utility of an outcome can be determined, a utility function must be assessed across values of the base attributes. Procedurally this can be accomplished as follows:

- 1) Specify the most and least desirable states of the base attribute. For example, the most desirable may be +500K dollars while the least desirable may be -200K dollars. Let these states be assigned arbitrary utilities of 100 and 0, respectively.
- 2) Select intermediate points and using a direct estimation, ratio; and/or lottery technique, determine their utility on the 0 to 100 scale. These techniques were presented in Step 4.

- 3) Graph the utility function for the base variable in order that states of the other attributes can be transformed into a corresponding utility figure through interpolation. Once the utility function has been graphed, it seems more psychologically sound to transform the utility scale by making zero utility equal zero units of the base variable, thus providing both positive and negative values for utility.

Figure III-47 shows an example of a graph for the utility of dollars. Some of the interpretations made from it are as follows. They also represent samples of the means by which the graph could have originally been constructed.

- a. There is as much utility to the system in obtaining 500K dollars as there is disutility in losing 200K dollars.
- b. The system represented by the decision maker is relatively indifferent to a 50:50 gamble between winning 500K dollars and losing - 200K dollars. The decision maker is, therefore, conservative and exhibits a substantial aversion toward risk since a risk neutral decision maker would accept the same gamble when the chances of winning the 500K dollars are only about 30 percent. $((p(500) + (1-p)(-200)) p = 28.6\%)$.
- c. There is as much utility to the system in receiving the 100K dollar increment from 200K to 300K as there is in receiving the 200K dollar increment from 300K to 500K. In other words there appears to be diminishing marginal utility for each additional 100K dollar increment.
- d. There is four times the disutility from losing the first 100K dollars as there is in losing the second 100K dollar increment. (Perhaps losing 100K is so damaging that the additional 100K cannot do that much more harm.)

The states of all attributes previously converted into units of the base dimension can now be translated directly into utilities by interpolating from the graph. The following example taken from Step 6 shows the results. Note that the utility scale having both positive and negative units is used. The original dollar values are shown in parentheses.

		<u>ATTRIBUTE</u>			
		$\$(x_4)$	Skill(x_3)	Motiv(x_2)	On-Job Flex(x_1)
O U T C O M E	A	50 (500K)	8 (30K)	2 (10K) Est.	5 (20K) Est.
	B	-50 (-200K)	5 (20K) Est.	-8 (-10K)	2 (10K) Est.
	C	-40 (-100K)	2 (10K) Est.	-5 (-5K) Est.	0 (0K)
	D	0 (0K)	0 (0K)	0 (0K)	0 (0K)

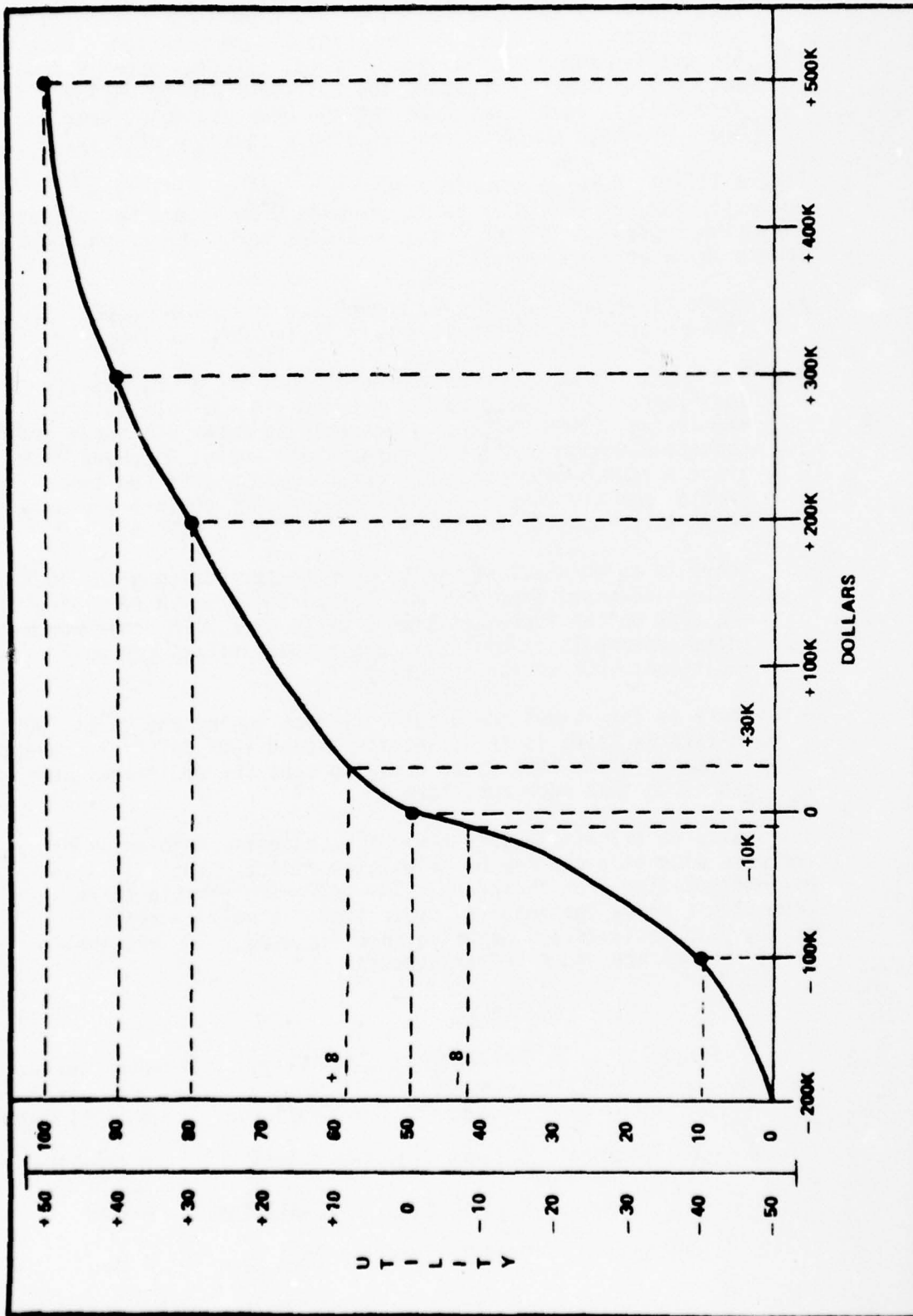

FIGURE III-47. GRAPHIC EXAMPLE OF A SYSTEM UTILITY FUNCTION OVER THE ATTRIBUTE, DOLLARS

The total utility for each outcome can be determined by adding across: Outcome A = 65, Outcome B = -51, Outcome C = -43, and Outcome D = 0.

An output report giving the variable values by outcome (DT04) will be produced as an output from this step.

7. The following technique will be applied when it has been determined that no dominant continuous base attribute exists. This and the following Step 8 will permit the development of a system utility figure for each decision tree outcome; thereby paralleling the objective of Steps 5 and 6 where there exists a dominant base variable.
 - 1) Consider the goal-related operational effects projected to be achieved from successful introduction of the innovation (points A_1 , A_2 , A_3 , and A_4 in Figure III-46).
 - 2) Select the most important effect considering the importance of the system goal (all points X_1^g in Figure III-46), the present status of the attribute, and the size of the incremental change resulting from successfully introducing the innovation into the system.
 - 3) Select the least important effect considering the same factors as in 2) above. These are the points designated as X_1^l in Figure III-46.
 - 4) Rank all other attributes considering the same factors as in 2).
 - 5) Assign the most important attribute selected in 2) a value of 1.0. Directly estimate the importance of other attributes in relation to the most important one.
 - 6) Check the consistency of the importance weights assigned by the direct estimate technique by performing one or more of the following additional techniques for estimating importance.
 - a) Assess ratios of importance between all combinations.
 - b) Assess points of indifference using a lottery technique.

Returning to the example presented in Figure III-46, assume that the continuous base variable costs/savings (x_4) is relatively unimportant, and that it is felt more appropriate to use the procedures in Steps 7 and 8 for assessing the system utility at each outcome. The following sequence of thought-processes might illustrate the technique for arriving at relative importance values for the four attributes of Figure III-46.

TAEG REPORT NO. 40

- a. The most important attribute is Skill Level (x_3) since it is an important system goal and its present state is relatively low.
- b. Motivation is least important since it is presently at a fairly high level.
- c. On-Job Flexibility is considered more important than Cost/Savings because it contributes significantly to overall mission in terms of preparedness.
- d. Skill Level is assigned a value of 1.0; the remainder in order are On-Job Flexibility, Cost/Savings, then Motivation.
- e. The Motivation attribute is less than half as important as Skill Level; it is therefore assigned an initial value of .4.
- f. On-Job Flexibility is nearly as important as Skill Level. Motivation is about half as important as On-Job Flexibility, therefore On-Job Flexibility is assigned a value of .8.
- g. The Cost/Savings variable is slightly more important than Motivation, and is judged about half as important as Skill Level; it is, therefore assigned a value of .5.

The final importance weights to be assigned each of the four attributes will be:

Skill Level	- 1.0
On-Job Flexibility	- .8
Cost/Savings	- .5
Motivation	- .4

These will be applied to the scales shown by the example in Figure III-46 to develop a system utility by outcome.

- 8. At the conclusion of Step 7 each benefit variable has been quantified in terms of contribution to some specific goal, and its weight of relative importance to the overall system mission has been estimated. In this step, the relative importance weighting factor will be applied to adjust the lengths for each attribute; the result will be a corresponding assignment of system utility to each outcome of the rescaled attributes. The following technique is applied to determine the utility for each outcome. Figure III-48 presents an example of the results.
 - 1) Assign an arbitrary scale for system utilities with zero as the midpoint, the midpoint representing the present system state.
 - 2) Select the scaled attribute weighted as most important and anchor its present state (point D) at the zero point of the arbitrary scale.

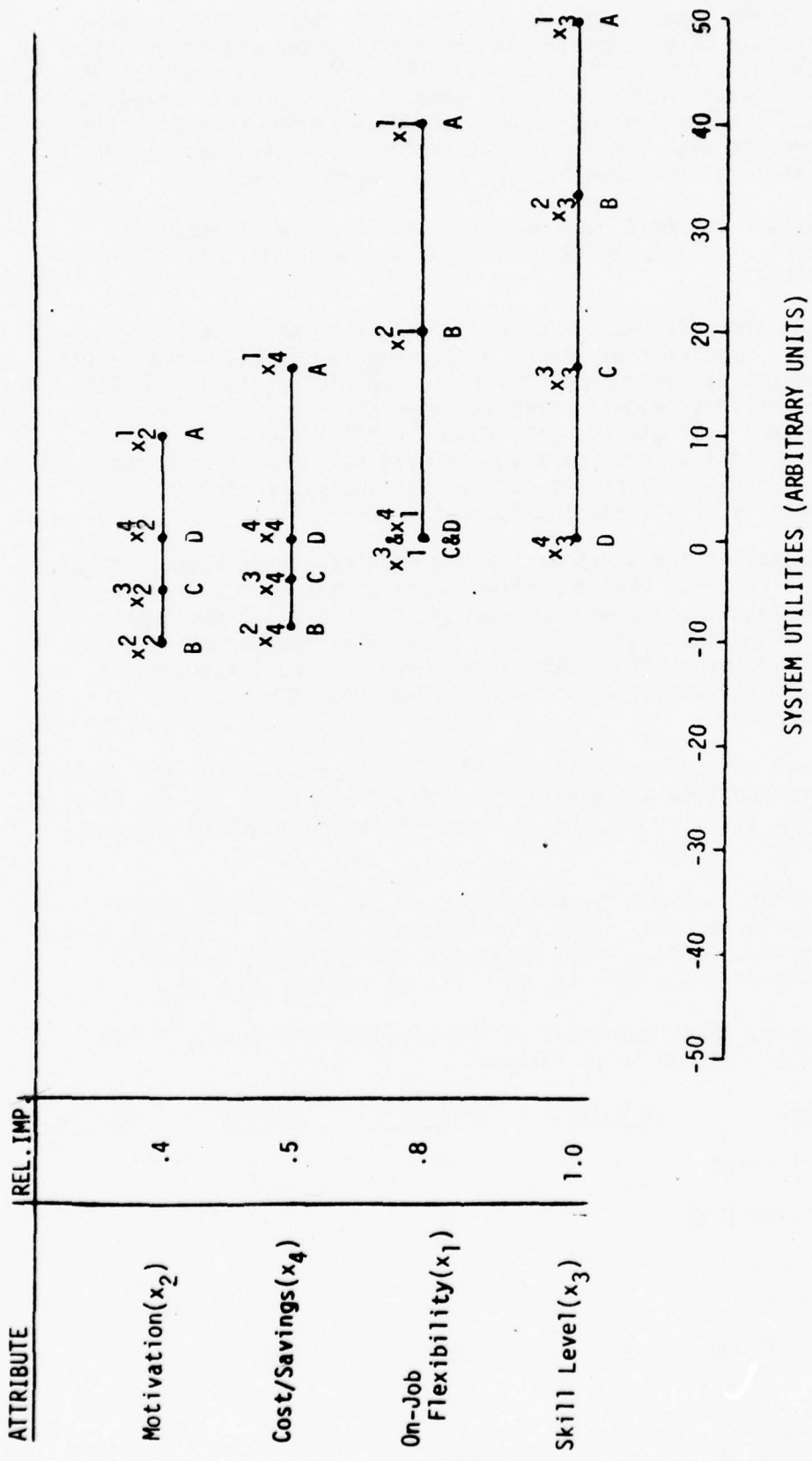

FIGURE III-48. APPLICATION OF IMPORTANCE WEIGHTS TO DEVELOP OVERALL SYSTEM UTILITY BY OUTCOME

- 3) Let the total length of the most important attribute scan exactly 50 percent of the arbitrary system utilities scale (this is for convenience and will permit all other attributes of lesser importance to be contained within the scale). Skill Level (x_3) in Figure III-48 is shown to extend from zero to plus fifty since its anchor point (D) was at the left most point on its scale in Figure III-46.
- 4) Select the next most important attribute and anchor its present state (point D) to the zero point of the arbitrary scale.
- 5) Let the total length be proportional to the length of the most important attribute based upon its relative importance weight as determined in Step 7. In Figure III-48, On-Job Flexibility with a relative importance of .8 is shown to extend a length of forty system utility units (.8 x 50). Since its anchor point (D) is also at the left most point on its scale from Figure III-46, it is shown to extend from zero to plus forty in Figure III-48.
- 6) Repeat 4) and 5) above for the remaining attributes. Figure III-46 shows that the other two attributes, Cost/Savings and Motivation, extend over twenty-five (.5 x 50) and twenty (.4 x 50) units, respectively. Since their anchor points (D) are between other outcome points, their scales extend in both a positive and negative direction from the zero or midpoint.
- 7) Read the system utilities for all A outcomes from the scale and add them algebraically. Thus from Figure III-48, $x_2^1 = 10$, $x_4^1 = 17$, $x_1^1 = 40$, and $x_3^1 = 50$; the total of all A outcomes is 117.
- 8) Repeat 7) above for Outcomes B, C and D. Outcome D will always be zero. Thus from Figure III-48, $x_2^2 = -10$, $x_4^2 = -8$, $x_1^2 = 20$, and $x_3^2 = 34$; Outcome B total is 36. Outcome C totals 8 with $x_2^3 = -5$, $x_4^3 = -4$, $x_1^3 = 0$ and $x_3^3 = 17$.

In summary, then, the total of the relevant attributes across each major outcome is as follows:

<u>ATTRIBUTE</u>	<u>OUTCOME A</u>	<u>OUTCOME B</u>	<u>OUTCOME C</u>	<u>OUTCOME D</u>
Motivation(x_2)	10	-10	-5	0
Cost/Savings(x_4)	17	-8	-4	0
On-Job Flexi- bility(x_1)	40	20	0	0
Skill Level(x_3)	<u>50</u>	<u>34</u>	<u>17</u>	<u>0</u>
Total	117	36	8	0

TAEG REPORT NO. 40

These are the utility figures which will be inserted into the decision tree after a consistency check has been performed in Step 9.

As a result of this step an output report giving the variable values by outcome (DT04) will be generated for the assessor to review.

9. At this point in the procedure, some system utility for each decision tree outcome will have been generated, either as a result of the conversion of relevant variables into units of a continuous base variable as was performed in Steps 5 and 6, or through application of the techniques outlined in Steps 7 and 8. Both Steps 6 and 8 recommended crosschecks for the consistency of the subjective estimates. In this step, a wholistic common sense appraisal of the relative total utility of each outcome is proposed. The consistency check steps are as follows:

- 1) Check the ranking of the outcomes for reasonability. From the examples summarized at the end of Steps 6 and 8, the following total utilities by outcome were obtained.

	<u>Step 6</u>	<u>Step 8</u>
OUTCOME A	65	117
OUTCOME B	-51	36
OUTCOME C	43	8
OUTCOME D	1	0

As is seen the results are quite different between the two, however, the assumptions were quite different and there was no intent that the results in any way be similar.

At this stage, the assessor should make the intuitive assessment on the order of outcomes for each of the innovations leading to the above summarized results.

- a) Is the order reasonable for the innovation processed through Step 6, i.e., A, D, C, then B?
- b) Is the order reasonable for the innovation processed through Step 8, i.e., A, B, C, then D? Does it seem reasonable that acceptance of the innovation, no matter what the final outcome, will provide more utility to the system than outright rejection?
- 2) Check the ratios of outcomes to one another for reasonableness.
- a) From the Step 6 results, does Outcome B appear to provide as much negative utility as Outcome A provides positive utility? Are Outcomes B and C just about as bad for the system?

TAEG REPORT NO. 40

- b) From the Step 8 results, does Outcome A appear to provide over three times the utility as Outcome B?
- 3) If the results of 1) and 2) above do not appear to be reasonable in terms of the separations of the values of the outcomes, and their negative or positive direction with respect to the present system state, reexamine the following.
 - a) Have all relevant variables (impacts of the innovation) been explicitly identified and/or taken into account?
 - b) Have realistic scenarios been created for each outcome considering operational effects?
 - c) Have the individual attributes been realistically assessed with respect to the system's goals?
 - d) Have the attributes been weighted realistically?

Outputs: The major program outputs and their destination are:

- 1) The final list of relevant variables to which values will be assigned. These will be selected from the list originally stored in the VQAL project file, and along with the Cost/Savings variable, will be stored in the VARF project file.
- 2) The relative importance of each of the relevant variables. An importance weighting factor from .1 to 1.0 will be assigned to each variable and stored in the VARF project file in the data record for the variable.
- 3) The weighted value of each relevant variable (including Cost/Savings) for each of the potential decision outcomes. These values will be developed by the assessor and stored in the VARF project file.
- 4) A total of the weighted values of each relevant variable for each potential decision outcome. These will be calculated by the program and stored as a separate data record (999 record) in the VARF project file.
- 5) The graphical characterization of the outcome states by scaled variable will be presented in an ETAM DECISION OUTCOME STATES BY SCALED VARIABLE (DT02) report. The format of this report is shown in Figure III-49. The SEQ NO (G1-Z1) and VARIABLE NAME (G2-Z2) columns are taken from the VARF file. REL IMP (G3-Z3) would represent an initial relative importance loaded into the VARF file since it is not developed interactively until process Step 7. Since it is stored in the VARF file as a number from 1 to 10, it must be scaled by a factor of 1/10th before entering on the DT02 report. The PERCENT OF DISTANCE TO GOAL STATE (G4-Z4) is developed interactively in process Step 4. An example of a DT02 report is shown in Figure III-50.

COL	1	2	3	4	5	6	7	8	9	0	1	2	3	4	5	6	7	8	9	0	1	2	3	4	5	6	7	8	9	0	
EDUCATIONAL TECHNOLOGY ASSESSMENT MCDL	1	2	3	4	5	6	7	8	9	0	1	2	3	4	5	6	7	8	9	0	1	2	3	4	5	6	7	8	9	0	
REPCRT	0	1	2	3	4	5	6	7	8	9	0	1	2	3	4	5	6	7	8	9	0	1	2	3	4	5	6	7	8	9	0
FCRM	1	2	3	4	5	6	7	8	9	0	1	2	3	4	5	6	7	8	9	0	1	2	3	4	5	6	7	8	9	0	
ETAM DECISION OUTCOME STATES BY SCALED VARIABLE	1	2	3	4	5	6	7	8	9	0	1	2	3	4	5	6	7	8	9	0	1	2	3	4	5	6	7	8	9	0	
DATE: **/ **/ **	1	2	3	4	5	6	7	8	9	0	1	2	3	4	5	6	7	8	9	0	1	2	3	4	5	6	7	8	9	0	
REPORT * OF *	1	2	3	4	5	6	7	8	9	0	1	2	3	4	5	6	7	8	9	0	1	2	3	4	5	6	7	8	9	0	
REL IMP T	1	2	3	4	5	6	7	8	9	0	1	2	3	4	5	6	7	8	9	0	1	2	3	4	5	6	7	8	9	0	
PERCENT CF DISTANCE TO GOAL	1	2	3	4	5	6	7	8	9	0	1	2	3	4	5	6	7	8	9	0	1	2	3	4	5	6	7	8	9	0	
STATE	1	2	3	4	5	6	7	8	9	0	1	2	3	4	5	6	7	8	9	0	1	2	3	4	5	6	7	8	9	0	
AB	1	2	3	4	5	6	7	8	9	0	1	2	3	4	5	6	7	8	9	0	1	2	3	4	5	6	7	8	9	0	
CD	1	2	3	4	5	6	7	8	9	0	1	2	3	4	5	6	7	8	9	0	1	2	3	4	5	6	7	8	9	0	
EF	1	2	3	4	5	6	7	8	9	0	1	2	3	4	5	6	7	8	9	0	1	2	3	4	5	6	7	8	9	0	
GH	1	2	3	4	5	6	7	8	9	0	1	2	3	4	5	6	7	8	9	0	1	2	3	4	5	6	7	8	9	0	
IJK	1	2	3	4	5	6	7	8	9	0	1	2	3	4	5	6	7	8	9	0	1	2	3	4	5	6	7	8	9	0	
LMN	1	2	3	4	5	6	7	8	9	0	1	2	3	4	5	6	7	8	9	0	1	2	3	4	5	6	7	8	9	0	
OPQ	1	2	3	4	5	6	7	8	9	0	1	2	3	4	5	6	7	8	9	0	1	2	3	4	5	6	7	8	9	0	
RST	1	2	3	4	5	6	7	8	9	0	1	2	3	4	5	6	7	8	9	0	1	2	3	4	5	6	7	8	9	0	
UVW	1	2	3	4	5	6	7	8	9	0	1	2	3	4	5	6	7	8	9	0	1	2	3	4	5	6	7	8	9	0	
XYZ	1	2	3	4	5	6	7	8	9	0	1	2	3	4	5	6	7	8	9	0	1	2	3	4	5	6	7	8	9	0	
COL	1	2	3	4	5	6	7	8	9	0	1	2	3	4	5	6	7	8	9	0	1	2	3	4	5	6	7	8	9	0	
1	1	2	3	4	5	6	7	8	9	0	1	2	3	4	5	6	7	8	9	0	1	2	3	4	5	6	7	8	9	0	
2	1	2	3	4	5	6	7	8	9	0	1	2	3	4	5	6	7	8	9	0	1	2	3	4	5	6	7	8	9	0	
3	1	2	3	4	5	6	7	8	9	0	1	2	3	4	5	6	7	8	9	0	1	2	3	4	5	6	7	8	9	0	
4	1	2	3	4	5	6	7	8	9	0	1	2	3	4	5	6	7	8	9	0	1	2	3	4	5	6	7	8	9	0	
5	1	2	3	4	5	6	7	8	9	0	1	2	3	4	5	6	7	8	9	0	1	2	3	4	5	6	7	8	9	0	
6	1	2	3	4	5	6	7	8	9	0	1	2	3	4	5	6	7	8	9	0	1	2	3	4	5	6	7	8	9	0	
7	1	2	3	4	5	6	7	8	9	0	1	2	3	4	5	6	7	8	9	0	1	2	3	4	5	6	7	8	9	0	
8	1	2	3	4	5	6	7	8	9	0	1	2	3	4	5	6	7	8	9	0	1	2	3	4	5	6	7	8	9	0	
9	1	2	3	4	5	6	7	8	9	0	1	2	3	4	5	6	7	8	9	0	1	2	3	4	5	6	7	8	9	0	
0	1	2	3	4	5	6	7	8	9	0	1	2	3	4	5	6	7	8	9	0	1	2	3	4	5	6	7	8	9	0	
1	1	2	3	4	5	6	7	8	9	0	1	2	3	4	5	6	7	8	9	0	1	2	3	4	5	6	7	8	9	0	
2	1	2	3	4	5	6	7	8	9	0	1	2	3	4	5	6	7	8	9	0	1	2	3	4	5	6	7	8	9	0	
3	1	2	3	4	5	6	7	8	9	0	1	2	3	4	5	6	7	8	9	0	1	2	3	4	5	6	7	8	9	0	
4	1	2	3	4	5	6	7	8	9	0	1	2	3	4	5	6	7	8	9	0	1	2	3	4	5	6	7	8	9	0	
5	1	2	3	4	5	6	7	8	9	0	1	2	3	4	5	6	7	8	9	0	1	2	3	4	5	6	7	8	9	0	
6	1	2	3	4	5	6	7	8	9	0	1	2	3	4	5	6	7	8	9	0	1	2	3	4	5	6	7	8	9	0	
7	1	2	3	4	5	6	7	8	9	0	1	2	3	4	5	6	7	8	9	0	1	2	3	4	5	6	7	8	9	0	
8	1	2	3	4	5	6	7	8	9	0	1	2	3	4	5	6	7	8	9	0	1	2	3	4	5	6	7	8	9	0	
9	1	2	3	4	5	6	7	8	9	0	1	2	3	4	5	6	7	8	9	0	1	2	3	4	5	6	7	8	9	0	
0	1	2	3	4	5	6	7	8	9	0	1	2	3	4	5	6	7	8	9	0	1	2	3	4	5	6	7	8	9	0	

FIGURE III-49. FORMAT OF ETAM DECISION OUTCOME STATES BY SCALED VARIABLE REPORT (DT02)

EDUCATIONAL TECHNOLOGY ASSESSMENT MODEL REPORT FORM		REPORT DT02	
000000001111111122222222333333334444444455555555666666667777777788			
1234567890123456789012345678901234567890123456789012345678901234567890			
COL111222222222222222222222333344			COL
ETAM DECISION OUTCOME STATES BY SCALED VARIABLE			
DATE: 3/17/77 --- REPORT 1 OF 1			
SEQ NO	VARIABLE NAME	REL IMP	PERCENT OF DISTANCE TO GOAL STATE
000 COST/SAVINGS		T---1---2---3---4---5---6---7---8---9---	----
001 ON-JOB-FLEXIBILITY		E-C-D-----A	
002 MOTIVATION		D	
003 SKILL LEVEL		C-----B-----A	
		B-C-D-----A	
		D-C-B-A	
000000001111111122222222333333334444444455555555666666667777777788			
1234567890123456789012345678901234567890123456789012345678901234567890			

FIGURE III-50. EXAMPLE OF ETAM DECISION OUTCOME STATES BY SCALED VARIABLE REPORT (DT02)

- 6) The ETAM DECISION OUTCOME STATES BY VARIABLE (DT03) report presents the variables as scaled in Step 8 to represent System Utilities. Columns 1, 2, and 3 are the same as defined in the DT03 report. Column 4 portrays the variables with the Reject outcome for each variable set to the zero point on the scale, and the remaining outcomes scaled by the relative importance factor. A SEQ NO 999 (Z1) record summarizes the system utilities by outcome (Z4). Figure III-51 shows the format of report DT03 and Figure III-52 provides an example.
- 7) Another summary report gives the ETAM DECISION VARIABLE VALUES BY OUTCOME (DT04). Figure III-53 shows the DT04 report format. Columns 1, 2, and 3 are the same as reports DT02 and DT03. Columns 4, 5, 6, and 7 give the quantification of the outcomes by variable as developed interactively either in Step 6 for continuous base attributes, or in Step 8 for non-continuous base attributes. Figures III-54 and III-55 give examples of the DT04 report for the cases when Steps 5-6 were taken or Steps 7-8 were followed, respectively.

Program P59 (Assigning Probabilities)

Purpose: The decision tree structure incorporated within ETAM requires the assessor estimate a number of probabilities associated with various decision outcomes. This program interactively prompts the user in assigning probability values to any of the decision tree nodes which were shown in Figure III-44. The probabilities on the path with NO RISK REDUCTION PROJECTS (DECO) are estimated based upon the risks which were outlined in the RKP file (Figure III-10.). These risks can be associated wither with getting the innovation physically implemented; i.e. designed, developed, manufactured, and installed, or with gaining user acceptance once the innovation is installed and operational. Thus, the assessor in performing this probability assignment function must have a clear concept of the implications of the identified risks upon the incorporation of the innovation into the system.

Probabilities may be estimated initially prior to creating the Project Data Base. This program may also be called as a part of the ETAM Risk Reduction Project Grouping (Program P56), or it may be used within the ETAM Decision Analysis function to refine the probabilities prior to running the program to calculate the decision variables. In all cases, the probabilities are stored in the RRPK file. Its format was previously described within the section on the Project Data Base, and an example of its contents were shown in Figure III-12.

In addition to estimating probabilities for for NO RISK PKG path, probabilities are required for each path for which a group of risk reduction packages has been defined.

Inputs: This program has the capability of permitting the assessor to print the RPK, RRPJ, and RRPK files via terminal control. Interactive terminal prompting elicits user responses which, hopefully, converge on a set of valid probability estimates for the nodes of the decision tree. The potential variables to be estimated are: PX, PW, PX1 thru PX9, PW1 thru PW9, PZ1 thru PZ9, and P11 thru P19.

EDUCATIONAL TECHNOLOGY ASSESSMENT MCODEL REPCRT FCRM REPORT DT03
C000CCCC011111112222222222333333333344444444445555555556666666667777777778
12345678901234567890123456789012345678901234567890123456789012345678901234567890
COL1112222222222222222222223333334444444444555555666666777777888888999999

ETAM DECISION OUTCOME STATES BY VARIABLE
CATE: **/** --- REPCRT * OF *

SEQ NO	VARIABLE NAME	REL	IPP	5	4	3	2	1	0	1	2	3	4	5
A														
B														
C														
D														
E														
F														
G														
H														
J														
K														
L														
M														
N														
P														
Q														
R														
S														
T														
U														
V														
W														
X														
Y														
Z														

999 TOTAL SYS UTILITY BY OUTCOME A = *** B = *** C = *** D = ***
000CCCC0111111222222222333333444444555555666666777777888888999999
12345678901234567890123456789012345678901234567890123456789012345678901234567890

FIGURE III-51. FORMAT OF ETAM DECISION OUTCOME STATES BY VARIABLE REPORT (DT03)

EDUCATIONAL TECHNOLOGY ASSESSMENT MODEL REPORT FORM REPORT DT04

000000001111111222222222333333444444555555666666777777888888999999
 1234567890123456789012345678901234567890123456789012345678901234567890

COL1112222222222222222222223333444444555555666666777777888888999999

SEQ NO	VARIABLE NAME	REL TMP	A	B	C	D
**	999 TOTAL EQUIV \$ BY OUTCOME	..	(*****)	(*****)	(*****)	(*****)
**	000000001111111222222222333333444444555555666666777777888888999999	..	(*****)	(*****)	(*****)	(*****)
**	1234567890123456789012345678901234567890123456789012345678901234567890	..	(*****)	(*****)	(*****)	(*****)

FIGURE III-53. FORMAT OF ETAM DECISION VARIABLE VALUES BY OUTCOME REPORT (DT04)

EDUCATIONAL TECHNOLOGY ASSESSMENT MODEL REPORT FORM REPORT DT04

00000000111111222222223333444455556666777788889999
 123456789012345678901234567890123456789012345678901234567890
 COL11122222222222222222223333444455556666777788889999

ETAM DECISION VARIABLE VALUES BY OUTCOME
 DATE: 3/17/77 --- REPORT 1 OF 1

SEQ NO	VARIABLE NAME	REL IMP	A	B	C	D
000	COST/SAVINGS	.5	500000	-200000	-100000	0
001	ON-JOB-FLEXIBILITY	.8	200000	100000	0	0
002	MOTIVATION	.4	100000	-100000	-50000	0
003	SKILL LEVEL	1.0	300000	200000	100000	0
999	TOTAL EQUIV \$ BY OUTCOME		560000	-180000	-95000	0

ABCDEF GHIJK LMNOPQRST UVWXYZ
 ABCDEF GHIJK LMNOPQRST UVWXYZ

00000000111111222222223333444455556666777788889999
 123456789012345678901234567890123456789012345678901234567890

FIGURE III-54. EXAMPLE OF ETAM DECISION VARIABLE VALUES BY OUTCOME REPORT (DT04)

TAEg REPORT NO. 40

Process: The major program process steps are:

1. Provide user with option to review RRPk file contents.
2. Permit selection of Risk Group (0-9) to be assigned probabilities.
3. Permit selection of specific probability groups to be estimated.
 - Group 1 - Probability of Risk Package Success
These probabilities would be assigned to the first three of the nine probabilities in the 1-1, 2-1, 3-1, etc. records of the RRPk file (the 0-1 record does not have any Risk Package). The first of the three probabilities represents the most pessimistic estimate, the middle probability the median estimate, and the third probability the most optimistic estimate.
 - Group 2 - Probability of Implementation Success
These probabilities would be assigned to the second three of the nine probabilities in the 0-1, 1-1, 2-1, 3-1, etc. records of the RRPk file. The three probabilities are in the same order as Group 1.
 - Group 3 - Probability of User Acceptance Success
These probabilities are assigned to the third three of the nine probabilities in the 0-1, 1-1, 2-1, 3-1, etc. records of the RRPk file. The three probabilities are in the same order as Group 1.
4. Estimate the probability selected. This is an interactive session which prompts the assessor until a reasonably valid estimate of the probability group under consideration has been made. The prompting sequence would start:*

ESTIMATE MOST OPTIMISTIC PROBABILITY OF (A) SUCCESS???

(A) depends on group chosen, i.e.,
Group 1 - (A) = RISK PKG
Group 2 - (A) = IMPLEMENTATION
Group 3 - (A) = USER ACCEPTANCE
User responds: 80 for example.

ESTIMATE MOST PESSIMISTIC PROBABILITY OF (A) SUCCESS???

User responds: 50 for example.

The program then sets up a series of three values and the user is requested to estimate his preference for the range into which the most likely probability falls. The two extreme values in this prompting sequence will be the prior OPTIMISTIC/PESSIMISTIC estimates. For example:

50 65 80

*This technique is based on the following reference. With the permission of Dr. Spetzler, a section of the referenced report is reproduced in Appendix E. Spetzler, Carl S. and Staël von Holstein, Carl-Axel S., 1972. Probability Encoding in Decision Analysis, paper presented at the ORSA-TIMS-AIEE 1972 Joint National Meeting, Atlantic City, N. J., 8-10 November 1972. Stanford Research Institute, Menlo Park, California.

T A E G R E P O R T N O . 4 0

If the user feels the most likely probability is in the 50 to 65 range rather than the 65 to 80 range, the user responds 12, i.e., range 1 is preferred to range 2. Based upon this response, the user is presented with a new set of values, for example:

50 60 80

If the user responds, 21; i.e., range 2 is preferred to range 1, another set of numbers would be printed.

50 63 80

This would continue until the user responds EQ; i.e., the ranges are equal and 63 represents the most likely value.

The middle value is calculated as: if the preference continues initially in the same direction, the first values are 1/6th of the difference between the optimistic and pessimistic $((80-50)/6 = 5)$. If the preference reverses, then the reversed value is $\frac{1}{2}$ of the value used in the previous sequence. A sample sequence is as follows:

20	50	80	<u>21</u>
20	60	80	<u>2T</u>
20	70	80	<u>T2</u>
20	65	80	<u>T2</u>
20	60	80	<u>2T</u>
20	63	80	<u>EQ</u>

The interval between the optimistic and pessimistic estimates is then trisected with the initial values dependent upon the results of the previous bisected sequence. For example, the initial values based upon a most likely value of 63 would be:

20 41 71 80

The value 41 is halfway between the pessimistic value of 20 and the previously selected most likely value of 63. Likewise, 71 is halfway between the most likely value of 63 and the optimistic value of 80.

The user is requested to order a preference for the three ranges; e.g., 321, range 3 (71-80) is preferred to range 2 (41-71), and range 2 is preferred to range 1 (20-41). The user continues to receive a presentation of ranges until a response 1=2=3 can be made. When two of the ranges are equal and preferred to the third, it is indicated as 1 = 23; i.e. range 1 and 2 are equal and preferred to range 3. A sample sequence is as follows:

20	41	71	80	<u>213</u>
20	41	67	80	<u>213</u>
20	41	65	80	<u>23T</u>
20	52	65	80	<u>T=23</u>
20	46	64	80	<u>2T=3</u>
20	49	63	80	<u>32T</u>
20	50	64	80	<u>EQ</u>

The algorithm for successive adjustments is similar to the bisection algorithm, that is initial movements in one direction are $\frac{1}{2}$ the difference that exists between the number being changed and the prior most likely estimate; e.g., $71-63 = 8$, $8/2 = 4$, $71-4 = 67$. This half adjusting continues until a change in the preference order is reflected in the user response, after which the other intermediate value; e.g. 41 is half adjusted. $63-41 = 22$, $22/2 = 11$, $63-11 = 52$.

This series of prompting can continue as shown by the example in Appendix E. Resolution of inconsistencies between the results of the several estimation paths should be reconciled and the most likely value selected for insertion.

5. Repeat Steps 4 and 5 until all probabilities have been estimated.
6. The values selected will be outputted to the RRPK file opposite the the NO RISK PKG (0-1), RISK PKG 1 (1-1), etc. records following the final iteration of Steps 4 and 5.

Outputs: The major outputs from this program are:

1. Displays to the user requesting selection of options.
 - o Assign Probabilities
 - o Instructions
 - o Quit
2. Prompting messages requesting preference orders for probability ranges.
3. Storage of the selected probability values in the RRPK file.

Program P60 (Calculate Decision Variables).

Purpose: This program calculates the decision variables for each alternative decision path. It provides an ETAM DECISION ANALYSIS DETAIL REPORT DT01. Program P60 is also the control program for the Decision Analysis function. It checks for available data to perform a decision tree calculation then provides the user with various select options for renewing Project Data Base files establishing qualitative variables, developing outcome utilities, assigning probabilities, or performing the decision tree calculations. The primary functions were shown in the previous Figure III-43.

Inputs: The major inputs to this program are:

1. VARF and RRPK data for determining if minimum data requirements are met for performing decision tree calculations.
2. User terminal selected options for controlling the processing sequence.
3. VARF and CMR file date for performing the decision tree calculations.

TAEG REPORT NO. 40

Process: The major process steps are:

1. Check RRPK file for existence of Record No. 0 which would indicate NO RISK PKG data are available for calculations.
2. Check VARF file for existence of Record No. 999 which would indicate a total record for the variable values stored in that file.
3. Set a RUN or NORUN condition flag based upon the availability of data in Steps 1 and 2.
4. The user is provided a display of the selection options which are:
 - o Review SCEN file
 - o Review VQAL file
 - o Review VARF file
 - o Establish qualitative variables pattern
 - o Run tree calculations
 - o Develop outcome utilities
 - o Assign probabilities
 - o Quit
5. The user selects one of these options from the terminal which will cause the branch either to program P1 to display the contents the VARF, VQAL, or or SCEN files; or to Program P58 to develop outcome utilities, or to Program P59 to assign probabilities, or to sections of P60 for either performing Decision Tree calculations or establishing the variables in the VQAL file.
6. Provided the data in RRPK and PARF was sufficient to run, the selection of the RUNDTREE calculations options will perform the calculations and print the DT01 report as previously outlined in the section entitled ETAM Decision Analysis Detail Report (DT01). The processing logic for these calculations is embodied in that section.
7. If the option to establish qualitative variables is selected the user will receive a display of the VQAL variables and be requested to select one of the variables for entry into the VARF file. Movement of that variable into the VARF file will permit that variable to be considered in the assessment of outcome utilities within Program P58.
8. Following completion of any of the options other than Quit, the user will be branched back to the display of the options for selection of another one.
9. The Decision Analysis function is exited by entering Quit when the select options are displayed.

Outputs: The major outputs of Program P60 are:

1. An ETAM Decision Analysis Detail Report (DT01) will result from the Decision Tree calculations program.
2. The output of the Decision Tree calculations will be placed in the TRER file for future reference.
3. If the selected alternative contains a Risk Reduction package; i.e., the path 1, 2, ..., 9 is selected. The value of the Risk Reduction package; i.e., COST1, COST2, etc. is stored in the CMR file Project Total Record NO. 9.

ETAM FINANCIAL ANALYSIS. Financial reports may be generated by invoking the FIN routine. A Project Number is requested which initiates a search of the Alternate Project File for that project. A financial comparison of any two projects, one of which must include the primary project, may be run based upon the latest Cost Model Results for those two projects. Financial Analysis report FA01 will always be generated for the financial comparison requested. If a financial analysis of the primary project and all valid alternate projects is requested, an FA01 report will be generated for each, and in addition, an FA02 summary report will also be generated. Figure III-56 shows the process flow for the Financial Analysis routines within the ETAM Assessment function.

The major objectives in performing the financial analysis are to:

1. Develop a figure of merit (rate of return on investment) as well as other comparative factors for the proposed innovation and for any potential alternatives to the proposed innovation.
2. Develop a rate of return figure for the incremental investment required of one alternative over another.

The first objective is achieved by applying a discount factor to the investment and cost/savings streams such that the discounted present value of the two streams is equal. This rate of return on investment can be compared with the same calculations made for alternative investments to aid in making a selection decision. If the calculated value for any single proposal is below some acceptable threshold value, the decision to reject the proposal may be warranted. A similar approach can be taken by selecting the threshold discount rate and applying it to the investment and cost/savings streams. The difference or Net Present Value (NPV) of these two, if positive, provides another measure of worth for undertaking the project. As with the rate of return on investment figure, the NPV can be compared among investment alternatives for making a selection decision. Two other figures useful for comparing alternatives are (1) the Savings Investment Ratio which will be some figure greater than one if the NPV were positive, and (2) the Uniform Annual Cost that provides the average annual cost which is useful for comparing alternatives which have differing useful lives, i.e., different planning periods.

The second objective is achieved by taking mutually exclusive alternatives and calculating the previously identified figures of merit for differences in investment and cost/savings streams of each separate alternative. This provides figures of merit on the incremental investment required of one alternative over another.

These calculated values, plus the component values of the total investment and total recurring cost/savings, are presented in several financial reports.

ETAM Alternative Analysis Report (FA01). The following identifies data sources and calculational logic for generating the fields on the ETAM Alternative Analysis Report. Fields outlined on the report layout not described here are fixed, and are generated by the program format statements. A sample report showing data elements by column/row coordinate is shown in Figure III-57.

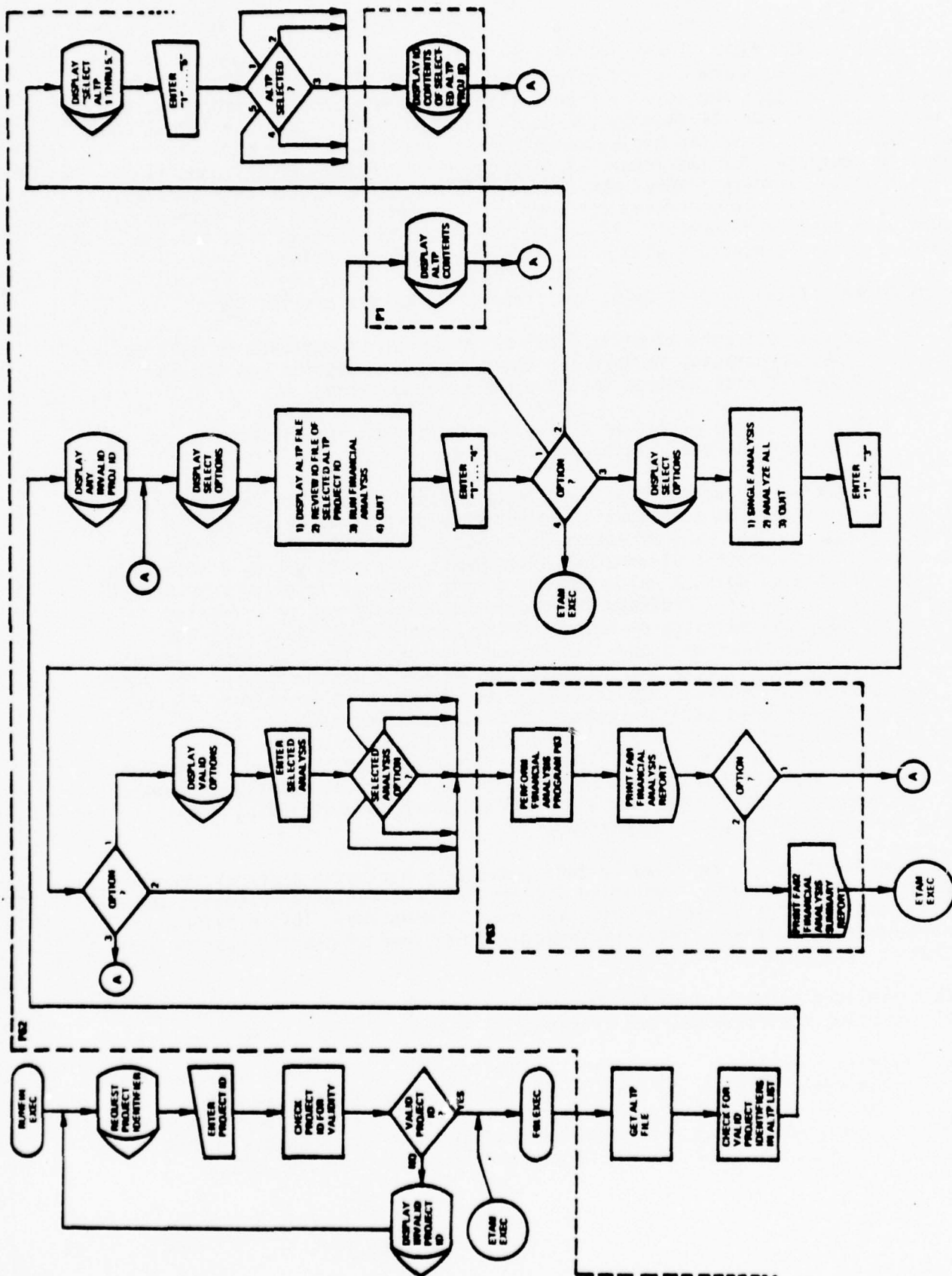

FIGURE III-56. ETAM FINANCIAL ANALYSIS (FIN) PROCESS FLOW

<u>COL/ROW</u>	<u>VARIABLE</u>	<u>DATA SOURCE AND/OR CALCULATIONAL LOGIC</u>
1C	- DATE	This field is generated within the system and developed as MM/DD/YY.
1E	- PROJA	This field represents the Project Number of the primary project under analysis and to which alternative projects will be compared. It will be passed to this routine as a parameter.
2E	- PROJ B	This field identifies an alternative project being compared. It may be identified by the user based upon a review of project numbers stored within the ALTP (Alternative Project) file in the Project Data Base. A parameter is generated as in 1E above.
1F	- YSRA	This field identifies the number of years over which the project (PROJA) has been analyzed. Its source is the CMR (Cost Model Results) project file for PROJA. Where the CMR contains output from more than one cost model and the years of project life are different, the greater number of years should be used.
2F	- YRSB	This field identifies the number of years over which the project (PROJB) has been analyzed. Its source is the CMR project file for PROJB. Where the CMR contains output from more than one cost model and the years of project life are different, the greater number of years should be used.
1J	- INV NDA	This field contains the sum of non-discounted annual investments for PROJA from the CMR for that project. This sum may contain the results of multiple cost model outputs as well as any investment from undertaking risk reduction projects.
2J	- INV NDB	This field contains the sum of non-discounted annual investments for PROJ B from the CMR for that project. This sum may contain the results of multiple cost model outputs as well as any investment from undertaking risk reduction projects.
3J	- INV NOT	= INV NDA - INV NDB
1K	- REC NDA	This field contains the sum of non-discounted annual recurring costs and saving for PROJA from the CMR for that project. This may contain the results of multiple cost model outputs.
2K	- REC NDB	This field contains the sum of non-discounted annual recurring costs and savings for PROJ B from the CMR for that project. This may contain the results of multiple cost model outputs.
3K	- REC NDT	= REC NDA-REC NDB

TAEG REPORT NO. 40

- 1M - INVPVA This field contains the sum of discounted annual investments for PROJA. This is the present value (PV) of the stream of investments summed into INVNDA and is calculated as:
- $$\left(- \frac{2+r}{2(1+r)^n}\right) \text{ for } n = 1 \text{ to the value of (YRSA - 1).}$$
- The value of r (discount rate) is either inputted by the assessor or defaults to .10 (10%).
- 2M - INVPVB This field contains the sum of discounted annual investments for PROJ B. This is the present value (PV) of the stream of investments summed into INVNDB, and is calculated as:
- $$\left(- \frac{2+r}{2(1+r)^n}\right) \text{ for } n = 1 \text{ to the value of (YRSB - 1).}$$
- The value of r (discount rate) must be the same as used for INVPVA.
- 3M - INVPVT = INVPVA - INVPVB
- 1N - ENDPVA This field contains the end (or salvage) value, discounted, for the PROJA investments included in INVPVA. Its source is the final year (YRSA) of the investment stream (INVNDA), discounted as: $\frac{2+r}{2(1+r)^n}$ where n = YRSB and r is the discount rate used for INVPVA.
- 2N - ENDPVB This field contains the end (or salvage) value, discounted, for the PROJ B investments included in INVPVB. Its source is the final year (YRSB) or the investment stream (INVNDB), discounted as: $\frac{2+r}{2(1+r)^n}$ where n = YRSB and r is the discount rate used for INVPVA.
- 3N - ENDPVT = ENDPVA - ENDPVB
- 1P - INVTA = INVPVA - ENDPVA
- 2P - INVTB = INVPVB - ENDPVB
- 3P - INVTT = INVTA - INVTB
- 1R - RECPVA This field contains the sum of discounted annual recurring costs and savings for PROJA. This is the present value (PV) of the stream of recurring costs/savings summed into RECND A. It is calculated similar to INVPVA.
- 2R - RECPVB This field contains the sum of discounted annual recurring costs and saving for PROJ B. This is the present value (PV) of the stream of recurring costs/savings summed into RECND B. It is calculated similar to INVPVB.
- 3R - RECPVT = RECPVA - RECPVB

TAEG REPORT NO. 40

- 1T - DISCA This field contains the discount rate applied to the various cost/savings streams in PROJA to calculate each of the present values. Its source is the assessor input for prior calculations or the default value of .10 (10%).
- 2T - DISCB This field contains the discount rate applied to the various cost/savings streams in PROJ B to calculate each of the present values. It is equal to DISCA.
- 3T - DISCT - DISCA = DISCB (both PROJA and PROJ B have been discounted at same rate).
- 1U - SIVRA - RECPVA/INVTA
- 2U - SIVRA - RECPVB/INVTB
- 3U - SIVRT - RECPVT/INVTT
- 1V - RORA This field is calculated by finding the value r in the equation $\frac{2+r}{2(1+r)^n}$ (where n = year) which applied to the investment stream summed into INVNDA and to the recurring costs/savings stream summed into RECND A makes the discounted values equal to each other. The CMR project file for PROJ B contains both vectors to be discounted.
- 2V - RORB This field is calculated by finding the value r in the equation $\frac{2+r}{2(1+r)^n}$ (where n = year) which applied to the investment stream summed into INVNDB and to the recurring costs/savings stream summed into RECND B makes the discounted values equal to each other. The CMR project file for PROJ B contains both vectors to be discounted.
- 3V - RORT This field is calculated by finding the value r in the equation $\frac{2+r}{2(1+r)^n}$ (where n = year) which applied to the vector difference (INVNDA* - INVNDB*) of investments and to the vector difference (RECND A* - RECND B*) for recurring cost/savings, makes the discounted values equal to each other. As previously outlined, the CMR project files for PROJA and PROJ B contain these vectors.
- 1W - UNIFA - INVTA/ $\left(\frac{2+r}{2(1+r)^n}\right)_{n=1}$ to YRSA where YRSA is the planning period for PROJA and r is the rate at which investment and cost/savings streams were discounted.
- 2W - UNIFB - INVTB/ $\left(\frac{2+r}{2(1+r)^n}\right)_{n=1}$ to YRSB where YRSB is the planning period for PROJ B and r is the rate at which investment and cost/savings streams were discounted.
- 3W - UNIFT - INVTT/ $\left(\frac{2+r}{2(1+r)^n}\right)_{n=1}$ to I where I is the greater of the planning periods for either PROJA or PROJ B, and r is the rate at which investment and cost/savings streams were discounted.

TAEG REPORT NO. 40

The results of each analysis of an alternative project against the primary project is stored in the FINR (Financial Results) project file. The entire FINR project file for the project under analysis routine is called to calculate new FA01 data, if, and only if, a different discount rate is used. Otherwise the new or repeat analysis due to an addition or change of an alternative project is entered into the FINR project file as a replacement if the alternative project number already exists, or as an addition if the alternative project number is new. The data elements in Column 1 of FA01 report are stored only once; the data elements in Column 3 are stored from each run of an FA01 report. The FINR data elements are essentially those which appear on the ETAM Alternative Analysis Summary Report (FA02). These data elements stored within the FINR project file are:

1C - DATE	
1E - PROJA	2E - PROJ B (1-5 if available)
1F - YRSA	2F - YRSB (1-5 if available)
1P - INVTA	3P - INVTT (1-5 if available)
1R - RECPVA	3R - RECPVT (1-5 if available)
1T - DISCA	
1V - RORA	3V - RORT (1-5 if available)
1W - UNIFA	3W - UNIFT (1-5 if available)

TAEG REPORT NO. 40

FA01 Variable List Summary.

<u>Var Name</u>	<u>I/O</u>	<u>Source/Destination</u>	<u>Report Ref</u>
DATE	0	INT GEN/FINR+RPT	1C
PROJA-B	I	EXEC PARAM/FINR+RPT	1E-2E
YRSA-B	I	CMR/FINR+RPT	1F-2F
INVNDA-B	I	CMR/RPT	1J-2J
INVNDT	0	CALC/RPT	3J
RECNDA-B	I	CMR/RPT	1K-2K
RECNDT	0	CMR/RPT	3K
INVPVA-B-T	0	CALC/RPT	1M-3M
ENDPVA-B-T	0	CALC/RPT	1N-3N
INVTA-T	0	CALC/FINR+RPT	1P+3P
INVTB	0	CALC/RPT	2P
RECPVA-T	0	CALC/FINR+RPT	1R+3R
RECPVB	0	CALC/RPT	2R
DISCA	I	INTERACTIVE/FINR+RPT	1T
DISCB-T	0	CALC/RPT	2T-3T
SIVRA-B-T	0	CALC/RPT	1U-3U
RORA-T	0	CALC/FINR+RPT	1V+3V
RORB	0	CALC/RPT	2V
UNIFA-T	0	CALC/FINR+RPT	1W+3W
UNIFB	0	CALC/RPT	2W

TAEG REPORT NO. 40

ETAM Alternative Analysis Summary Report (FA02). The following identifies the data sources and calculational logic for generating the fields on the ETAM Alternative Analysis Summary Report. Fields outlined on the report layout not described here are fixed, and are generated by the program format statements. A sample report showing data elements by column/row coordinate is shown in Figure III-58.

<u>COL/ROW</u>	<u>VAR</u>	<u>DATA SOURCE AND/OR CALCULATIONAL LOGIC</u>
3B	- DATE	This field is operated within the system and developed as MM/DD/YY.
1G	- PROJA	This field represents the Project Number of the primary project under analysis and to which Alternative Projects will be compared. It is stored within the FINR project file name (fn). (Same as FA01 1E-PROJA)
1H	- YRSA	This field identifies the number of years over which the project (PROJA) has been analyzed. It is stored within the FINR project file. (Same as FA01 1F-YRSA)
1K	- INVTA	This field contains the Total Present Value of the New Investment. It is calculated by taking the INVTA (Same as FA01 1P-INVTA) in the FINR project file and dividing by 1000. (INVITA/1000).
1L	- RECPVAK	This field contains the Total Present Value of the Recurring Cost/Savings stream. It is calculated by taking the RECPVA (Same as FA01 1R-RECPVA) in the FINR project file and dividing by 1000 (RECPVA/1000).
1M	- NPVAK =	RECPVAK-INVPAK
1P	- DISCA	This field contains the discount rate used to calculate the FA01 report and is obtained from the FINR project file. (Same as FA01 1T-DISCA).
1Q	- SIRVA =	RECPVAK/INVTA
1R	- RORA	This field contains the Rate of Return on Investment calculated for PROJA and stored in the FINR project file (same as FA01 1V-RORA).
1S	- UNIFA	This field contains the Uniform Annual Investment Cost calculated for PROJA and stored in the FINR project file (same as FA01 1W-UNIFA).
2G	- PROJ B1	This field identifies an alternative project which was compared to the primary project and outputted on an FA01 report. It will have appeared as a PROJ B on that report. It is stored within the FINR project file.
3G	- PROJ B2	
4G	- PROJ B3	
5G	- PROJ B4	
6G	- PROJ B5	

EDUCATIONAL TECHNOLOGY ASSESSMENT MODEL REPORT FORM REPORT FA02

000000001111111122222222333333334444444455555555666666667777777788
 1234567890123456789012345678901234567890123456789012345678901234567890

COL0000000000000000111111112222222233333333444444445555555566666666COL

ETAM ALTERNATIVE ANALYSIS SUMMARY REPORT

DATE: **/**/**

	-PRIMARY- PROJECT				ALTERNATIVE PROJECTS			
	PN***	PN***	PN***	PN***	PN***	PN***	PN***	PN***
A PROJECT IDENTIFIER	(*****)	(*****)	(*****)	(*****)	(*****)	(*****)	(*****)	(*****)
B PROJECT LIFE IN YEARS	(*****)	(*****)	(*****)	(*****)	(*****)	(*****)	(*****)	(*****)
C TOT PV NEW INV (\$K)	(*****)	(*****)	(*****)	(*****)	(*****)	(*****)	(*****)	(*****)
D TOT PV REC CST/SAV	(*****)	(*****)	(*****)	(*****)	(*****)	(*****)	(*****)	(*****)
E NET PRESENT VALUE	(*****)	(*****)	(*****)	(*****)	(*****)	(*****)	(*****)	(*****)
F DISCOUNT RATE (PCT)	**.	**.	**.	**.	**.	**.	**.	**.
G SAVINGS INV RATIO	**.	**.	**.	**.	**.	**.	**.	**.
H RATE OF RET ON INV	**.	**.	**.	**.	**.	**.	**.	**.
I UNIFORM ANNUAL COST	(*****)	(*****)	(*****)	(*****)	(*****)	(*****)	(*****)	(*****)

000000001111111122222222333333334444444455555555666666667777777788
 1234567890123456789012345678901234567890123456789012345678901234567890

FIGURE III-58. FORMAT OF ETAM ALTERNATIVE ANALYSIS SUMMARY REPORT (FA02)

TAEG REPORT NO. 40

2H	-	YRSB1		This field identifies the number of years the project was analyzed. It will have appeared as a YRSB on the FA01 report. It is stored within the FINR project file.
3H	-	YRSB2		
4H	-	YRSB3		
5H	-	YRSB4		
6H	-	YRSB5		
2K	-	INVTT1		This field contains the Net Difference in the Total Present Value of the New Investment for the Primary Project and the particular Alternative Project. It is calculated by taking the INVTT (same as FA01 3P-INVTT) in the FINR project file and dividing by 1000 (INVTT/1000).
3K	-	INVTT2		
4K	-	INVTT3		
5K	-	INVTT4		
6K	-	INVTT5		
2J	-	RECPVT1		This field contains the Net Difference in the Total Present Value of the Recurring Cost/Savings for the Primary Project and the particular Alternative Project. It is calculated by taking the RECPVT (same as FA01 3R-RECPVT) in the FINR project file and dividing by 1000 (RECPCT/1000).
3J	-	RECPVT2		
4J	-	RECPVT3		
5J	-	RECPVT4		
6J	-	RECPVT5		
2M	-	NPVT1	=	RECPVT1-INVTT1
3M	-	NPVT2	=	RECPVT2-INVTT2
4M	-	NPVT3	=	RECPVT3-INVTT3
5M	-	NPVT4	=	RECPVT4-INVTT4
6M	-	NPVT5	=	RECPVT5-INVTT5
2P	-	DISCT1	=	DISCA
3P	-	DISCT2	=	DISCA
4P	-	DISCT3	=	DISCA
5P	-	DISCT4	=	DISCA
6P	-	DISCT5	=	DISCA
2Q	-	SIVRT1	=	RECPVT1/INVTT1
3Q	-	SIVRT2	=	RECPVT2/INVTT2
4Q	-	SIVRT3	=	RECPVT3/INVTT3
5Q	-	SIVRT4	=	RECPVT4/INVTT4
6Q	-	SIVRT5	=	RECPVT5/INVTT5
2R	-	RORT1		This field contains the Rate of Return on Investment calculated for the Net Difference in the Investment and Recurring Cost/Savings vectors for the primary and alternative project, and stored in the FINR project file (same as FA01 3V-RORT).
3R	-	RORT2		
4R	-	RORT3		
5R	-	RORT4		
6R	-	RORT5		
2S	-	UNIFT1		This field contains the Uniform Annual Investment Cost calculated for the Net Difference between the Primary Project and an Alternative Project, and stored in the FINR project file (same as FA01 3W-UNIFT).
3S	-	UNIFT2		
4S	-	UNIFT3		
5S	-	UNIFT4		
6S	-	UNIFT5		

TAEG REPORT NO. 40

FA02 Variable Summary.

<u>Var Name</u>	<u>I/O</u>	<u>Source/Destination</u>	<u>Report Ref</u>
DATE	0	INT GEN/RPT	3B
PROJA	I	FINR/RPT	1G
YRSA	I	FINR/RPT	1H
INVTAK	0	CALC/RPT	1K
RECPVAK	0	CALC/RPT	1L
NPVAK	0	CALC/RPT	1M
DISCA	I	FINR/RPT	1P
SIRVA	0	CALC/RPT	1Q
RORA	I	FINR/RPT	1R
UNIFA	I	FINR/RPT	1S
PROJB1-5	I	FINR/RPT	2G-6G
YRSB1-5	I	FINR/RPT	2H-6H
INVT1-5	0	CALC/RPT	2K-6K
RECPV1-5	0	CALC/RPT	2J-6J
NPV1-5	0	CALC/RPT	2M-6M
DISCT1-5	0	CALC/RPT	2P-6P
SIVRT1-5	0	CALC/RPT	2Q-6Q
RORT1-5	I	FINR/RPT	2R-6R
UNIFT1-5	I	FINR/RPT	2S-6S

Rate of Return on Investment Algorithms. The calculation of the Rate of Return on Investment required in the Financial Analysis routine is performed by an iterative algorithm as follows:

1. Make an initial estimate of the Rate of Return (RORE) by assuming the total investment takes place at time $t = 4$ and that the savings stream (RECND*) occurs in equal installments over the planning period (N)

The cumulative annual discount factor (RCUM) would discount an equal amount savings stream (RECND*)/N to the value of the investment stream (INVND*) is given by

$$a) \quad RCUM = (INVND* * N)/RECND*$$

A polynomial of order N must be solved for the Rate of Return to establish the initial value. The polynomial is defined as:

$$b) \quad \sum_{k=1}^{k=N-1} \left(\frac{N!}{(N-k)!k!} * RCUM - \frac{N!}{(N-k-1)!(k+1)!} \right) RORE^k + RCUM * RORE^N = 0$$

If the savings stream were actually in equal annual amounts, and the investment all took place at $t = 0$, this calculation will produce an RORE which will be higher than the true rate since the polynomial is based upon the formula for the savings occurring at the end of each year; i.e.:

$$c) \quad \sum_{k=1}^{k=N} 1/(1+RORE)^k,$$

rather than the formula for the savings occurring throughout the year, i.e.:

$$d) \quad \sum_{k=1}^{k=N} (2+RORE)/(2(1+RORE)^k)$$

An algorithm for evaluating the polynomial b) is shown in the following flow, Figure III-59.

2. Since the initial estimate will generally be slightly high, choose a value approximately .01 (1%) lower than the RORE solution from 1. above. Using the formula 1.d), discount both the investment stream (INVND*) and the recurring savings stream (RECND*) over the planning period (N).

$$a) \quad INVPV = \sum_{k=1}^{k=N} INVND^k * (2+RORE)/(2(1+RORE)^k)$$

$$RECPV = \sum_{k=1}^{k=N} RECND^k * (2+RORE)/(2(1+RORE)^k)$$

If RECPV is greater than the investment INVPV then the value of RORE is too small and should be increased by .005 (.5%). If RECPV is less, then reduce RORE by .01 (1%). Repeat the process by halving the increment/decrement values on each successive iteration until RORE is calculated to the desired level of accuracy. To ensure that a continuous loop is not encountered, a suitable test should be set up to cause an exit from the routine. An example of an iterative sequence is shown in the following flow, Figure III-59.

Program P62 (Financial Analysis Setup).

Purpose: This program establishes the run parameters for the Financial Analysis calculations and reports to be performed by program P63. It provides the user with interactive capability to produce several of the Project Data Base files, to run the Financial Analysis Program, or to exit routine. The analysis requirements are established by identifying the alternate projects which are to be financially analyzed. The option to analyze all alternate projects in relation to the primary project is available to the user.

Inputs: The primary inputs to this program are:

- o ALTP file for identification of alternative projects.
- o User interactive terminal input to control the processing sequence.

Process: The following are the major process steps for Program P62:

1. The ALTP file is analyzed to determine if alternate project ID's exist and, if they represent valid project identifiers. Any invalid project identifiers are displayed.
2. The user receives a display of the select options. They are as
 - o Display ALTP file
 - o Review ID file of selected ALTP project ID
 - o Run Financial Analysis
 - o Quit
3. If the user selects either of the display or review options, Program P1 is called in order to display the contents of either the ALTP file or the contents of the ID file represented by the alternative project identifiers.
4. If the Run Financial Analysis option is selected, the user is displayed three options, namely:
 - o Single analysis
 - o Analyze all
 - o Quit

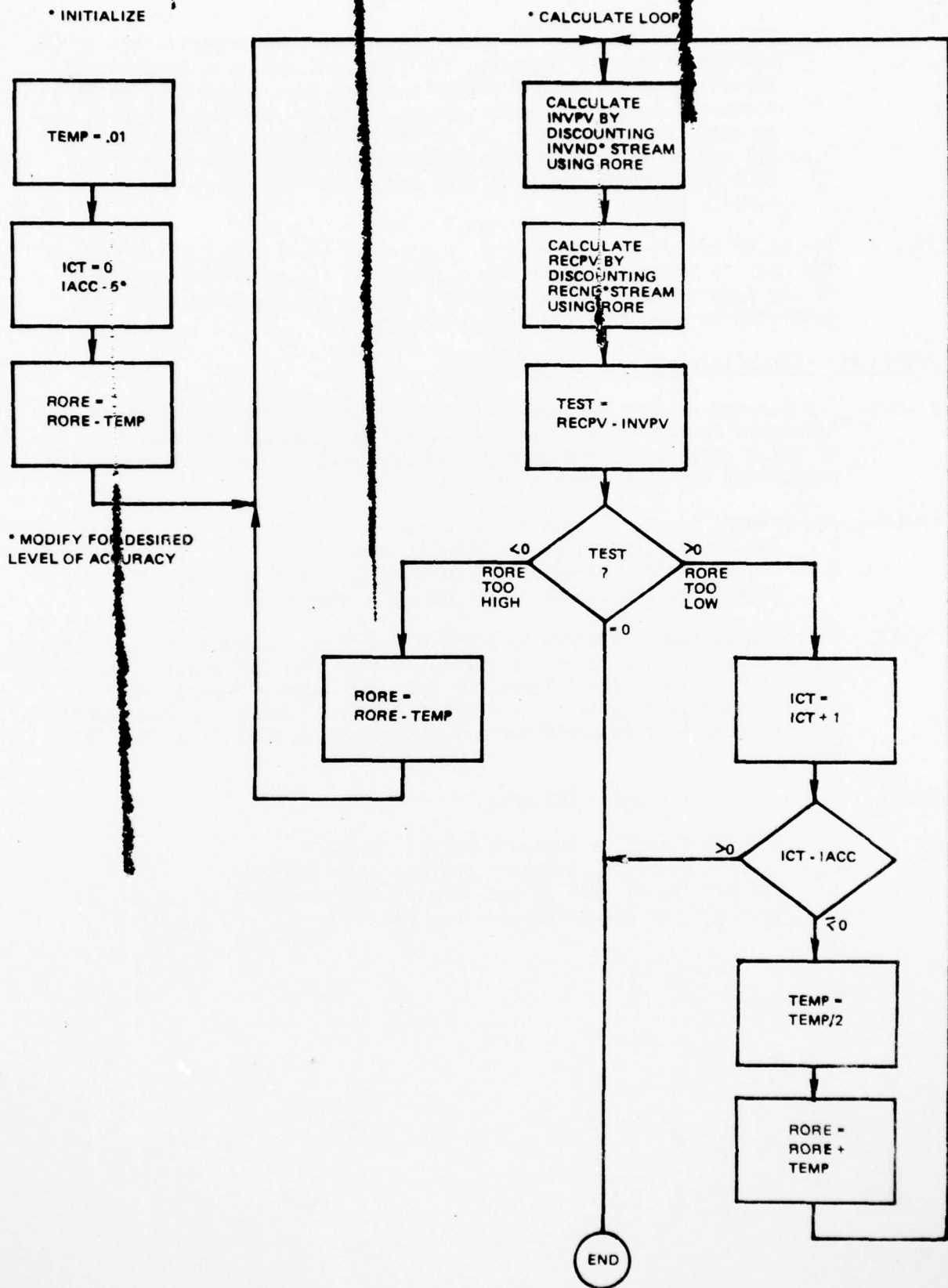

FIGURE III-59. EXAMPLE OF INTERACTIVE SEQUENCE FOR CALCULATING RETURN ON INVESTMENT (ROI)

5. The user selects one of these options and the program sets up the run conditions for entering the financial analysis Program P63. Selection of the single analysis option will cause only an FA01 Financial Analysis Report comparing the primary project with the selected ALTP project to be printed. Selection of the Analyze All option will cause Program P63 to print an FA01 report for each ALTP within the ALTP file and a FA02 Financial Analysis Summary report.

Outputs: The major output of Program P62 is a series of displays which request the user to enter an option for controlling the processing sequence of the reports generated as a result of the selected sequences are generated by either Program P1 or Program P63.

Program P63 (Financial Analysis Calculations).

Purpose: The purpose of this program is to perform the financial calculations necessary to determine several financial measurement factors, and to print comparative and summary reports on the projects selected for comparison with the primary project.

Inputs: The primary inputs to this program are:

1. The run parameters established by Program P62.
2. The cost model results data previously established by the cost model runs and the Decision Analysis Program P60.

Process: The process steps required to perform the financial calculations were previously outlined in the sections entitled ETAM Alternative Analysis Report (FA01) and ETAM Alternative Analysis Summary Report (FA02). A computational algorithm for computing Rate of Return on Investment is presented in a separate section following the outline of the FA02 report.

Outputs: The outputs of Program P63 are:

1. An ETAM Financial Analysis Report (FA01)
2. An ETAM Financial Analysis Summary Report (FA02).
3. The results of each of the financial comparisons calculated by this program are stored in the FINR file.

SECTION IV

CONCLUSIONS AND RECOMMENDATIONS

CONCLUSIONS

The following conclusions are based upon a rather broad investigation into the use of models and procedural techniques in the decision making process. Much of the literature deals with highly theoretic concepts which are difficult to apply to the pragmatic requirements of making and implementing a decision. These conclusions are based upon the level of design and development achieved to this point on the Educational Technology Assessment Model. Range-of-Effect was developed to a functioning level, however, the Abbreviated Data Bases which are the objects of the Range-of-Effect search contain a limited subset of the Courses, Vehicles, and Job/Tasks relative to naval training and operations. Thus, these conclusions do not reflect any substantial use of a computerized version of ETAM, but rather consider the techniques inherent in the application of ETAM to the general decision-making process.

ETAM continues to appear a robust model of rational decision making in general and for changes (innovations) in training technology in particular. Its strengths come from two major factors that have dominated its development: (a) the basic tasks in the analytic and decision-making sequence are prototypical of informed common sense rationality, and (b) the computer is used not to hide or obscure this rational structure, but to help the humans to apply it by exposing it. The computer is a convenience, at least in concept. In practice, because of the massive amounts of word data and numerical data to be manipulated, if the procedures are to be applied in their full scale, this convenience factor becomes magnified into a virtual necessity.

The taxonomic structures for describing Courses, Vehicles, and Job/Tasks provide important discriminants for searching out potential applications for the innovation. The coding of the sample entities showed some definite clustering of descriptors which might be expected due to the similarities in Navy training courses; e.g., maintenance, procedural, operator, etc. Refinements in the techniques for using the descriptor set should improve search validity.

Since the Range-of-Effect program development was completed, it was possible to determine the operational costs, at least in the application of the programs to the limited subsets of entities which were described in the Abbreviated Data Bases. Following are costs of a typical Range-of-Effect sequence:

Load Project Data Base (Program P17)	\$ 7 - \$ 8
Edit Search Descriptors (Program P2)	\$ 4 - \$ 5
Search Abbreviated Data Bases (Program P3)	3 - 4
Print Search Results (Program P5A)	3 - 4
Edit Search Results (Program P5B)	3 - 4
Print Extract Search Results (Program P5C)	<u>2 - 3</u>
Total Range-of-Effect Processing Cost	\$15 - \$20

Because the Assessment function within ETAM was completed only to a design level, it is not possible to predict typical operational costs for the processing sequences making up that function.

Extensive reports have been previously published describing the ETAM procedures. However, it was believed that it would be useful to the reader to reemphasize the basic ETAM functions by contrasting the procedures as they were originally envisioned for ETAM and supported by computer processing, with the "normal" reasonable way it would be performed. Following are summaries of the two approaches in contrast with one another.

TASK 1 - FORMALIZE THE DESCRIPTION OF THE INNOVATION.

Normal Procedure An informal prose statement is made about what the innovation or change is about, what it consists of, and descriptions of local effects in limited application environments. An interoffice project file may or may not be created.

ETAM Procedure. A structured format reminds the proposer of the innovation to set down all categories of information relevant to the innovation that dredges what the innovator has learned or knows about the costs, relevance, benefits, practical factors, supporting data, and expected R&D effort. A formal project file is initiated. The category format will enable direct referencing at later stages of investigation to these starting data.

TASK 2 - DEVELOP/EXAMINE ALTERNATIVES TO THE INNOVATION.

Normal Procedure. The proposal may have focused or defined an organizational need or problem. Discussions may develop competing proposals. Adversary relationships may produce arguments that blur the overall picture. The alternatives may or may not be formally recorded. They probably do not get associated with the project file.

ETAM Procedure. Alternatives are sought formally and documented according to the same format used for the source proposal. A deliberate attempt is made to achieve a simpler, less costly or less risky solution that may be less disruptive to existing or projected operations. Promising alternatives can be put through later ETAM procedures and compared directly, variable for variable, with each other and the source proposal at decision stages.

TASK 3 - MAKE PRELIMINARY FEASIBILITY PROFILE.

Normal Procedure. This step may be performed informally in verbal discussions but without clear and documented outcomes. One or two issues may lead to neglect of the others. The factors include importance of the outcome to the organizational mission, compatibility with organizational policy, operations and goals, state-of-the-art, R&D funding, technical support, and attitudinal acceptance. The overall impression may be so negative that the proposal is dropped.

ETAM Procedure. The major feasibility factors are all covered and experts express their opinions on attitude scales which become essential documented

TAEG REPORT NO. 40

references that formally enter into the decision structure. The summary of feasibility may indicate clearly that the proposal should now be dropped without further analysis. The clearly expressed evaluations on each significant variable may be revised in the light of further information that has direct bearing. All data, including revisions, are stored in the project file.

TASK 4 - PERFORM ANALYTIC FEASIBILITY ASSESSMENT.

Normal Procedure. Attention focuses on the weak spots and potentially high-risk areas in the proposal, especially as they involve costs and size of risk, activities that might ameliorate the risks but having a cost reference. Informed guesses may be made as to the range of effective usefulness of the innovation in order better to prorate the costs of implementation and acceptance. Tentative feasibility may appear or disappear at this stage. The project may be dissipated in a sea of controversy.

ETAM Procedure. Formal procedures are used for assessing grossly estimated risks and costs with and without supportive projects. Cost data are entered into defined categories that permit direct comparisons. Decision trees are developed from utility scaling procedures in order to obtain figures of merit for various outcomes. The operations for generating the source data and their conversion by human judgment into estimates of worth are explicit, and enter the project file.

TASK 5 - DETERMINE RANGE-OF-EFFECT.

Normal Procedure. If the proposal overcomes preliminary hurdles, further exploration is made into the range of situations or entities that could be affected beneficially or otherwise by the innovation. Because of the difficulty of expressing intangible benefits or liabilities in the operational context, they tend either to be lost or over-inflated. The readiness with which directly tangible cost savings can be defended tends to make for organizational conservatism in the acceptance of innovations. Range-of-effect determination tends to be limited to the knowledge of the individual staff expert about the operations of the enterprise and to his perception of the functions of the innovation.

ETAM Procedure. A formal structure of all major variables that go into the organizational mission is available to the analyst, expressed as a taxonomy for applying to processes (teaching and learning) and to entities (courses, devices, job-tasks). Entities are indexed according to their key properties relevant to the mission. The same taxonomy is used for indexing with descriptors the innovation. ETAM has built-in instruction to inform and guide the assessor who is less than omniscient. Automatic search and retrieval operations assist the human expert in determining the full range of entities and attributes that will be affected by the innovation. The listing of these entities can enter into automatic or manual cost analysis. The human expert, however, makes the final decision of relevance about each entity from context information not limited merely to the matching of descriptors.

TASK 6 PERFORM COST-BENEFIT ANALYSIS.

Normal Procedure. The enterprise may have formal cost models for its operations. These are now brought to bear on each of the relevant entities for which some proportional cost benefit (negative or positive) has been estimated. The wise estimator puts in a safety factor for his estimates by expressing a range of likely error with optimistic and pessimistic limits. Cost data are summarized. Other benefit and liability information is presented in prose discussions. The paper is apt to be voluminous.

ETAM Procedure. Entities identified by range-of-effect procedures automatically enter into their appropriate cost models, and costs are automatically aggregated. Input changes are therefore readily reflected in output changes. Utility scaling enables intangibles to be assessed on the same continuum of worth as tangible (i.e., cost) variables. All constituent operations are overt and documented, and can be related back to their source data. The resulting decision tree not only displays the estimated values of the decision alternatives, it also serves as a high level index for interrogating the sources of the conclusions. Automation of the calculational model enables quantitative evaluation of variables to which the decision outcomes are most sensitive, thus enabling focus on where major risks may lie.

TASK 7 PERFORM FINANCIAL ANALYSIS.

Normal Procedure. The investment required by the innovation is now viewed in the long-term and contrasted with alternative opportunities and needs for investments. This concern recognizes that any organization has limited capital and competing claims on that capital. Cost/savings analysis is made for each alternative, as well as for alternative proposals. The objective is to reconcile organizational priorities, limited capital, risk, and proposals for innovation with their respective costs and promises of benefits.

ETAM Procedure. This is a formal step with the same objectives. Multiyear projections of costs and savings are generated by machine calculations. The input data for making the calculations will already exist as content in the project file that has been developed in performing the previous tasks.

TASK 8 MAKE THE ACCEPT/REJECT/STUDY FURTHER DECISION.

Normal Procedure. The executive is presented with a brief statement of the problem and innovation and bottom-line summary data. These may be preceded by a flip chart presentation of topic statements and selected summary data. The backup may be a paper file of hundreds of pages. The executive sizes up the situation intuitively, asks his staff some "probing" test questions and arrives at an assessment of the competence with which the staff work was done. He makes an intuitive judgment of the comparative value of the innovation in the organizational scheme of things and makes or postpones a decision. On occasion, he may spend a weekend trying to digest the backup report.

ETAM Procedure. The executive is presented with a brief statement of the problem and the innovation, taken from Task 1. If he wishes more detail about the source data on the innovation, he can invoke the file on Task 1. He may request the display of the outcome. The decision tree and financial analysis are presented. He requests outputs from the sensitivity analyses to find out his exposures to

the precision of the estimates and judgments of the assessing staff. These are displayed at once. He may prefer to use his own intuitive and global judgment, so he invokes summaries of the data used by the assessor in Task 6 in developing the decision tree. Or, the executive challenges the implicit set of organizational values held by the assessing staff and, invoking the utility scaling operations of Task 6, modifies the respective utilities of several variables and immediately reviews the outcome on the recomputed decision tree. He may question the evaluations about feasibility by examining the structured data on each of the topic responses in Task 3. In the space of an hour, the executive can rove selectively through the project and "peel back" from summaries to data content to data source.

ETAM does not take away any of the traditional prerogatives of the executive, but augments them and enables a telescoping of time for investigative inquiry, rapid selective access, and standard formatting of key information.

Delivering this capability depends upon a suitable display terminal and an automatic access structure that is not a part of the completed ETAM work. But the data base structures now being devised will make this capability possible.

PROCEDURAL SUMMARY. The parallels between normative processes for arriving at decisions and ETAM procedures should be evident. It may be suggested, without emphasis, that political pressures may as readily be put into formal utility models as any other variables that affect desirability of one outcome over another.

ETAM represents, however, a shift from informal or semi-formal methods of analysis and synthesis of data to a formalism of what data are acquired, stored, accessed, combined with other data. But this formalism does not preclude non-formal processing by human staff and executive personnel. ETAM represents orderliness and organization that permits efficiency and consistency but, more important, it enables much larger amounts of pertinent information to be brought to bear on the decision process. In effect, a broader scope for optimizing (or satisfying) is brought to bear with a clearer picture of the range of consequences. These factors are at least as important as increases in the efficiency whereby decisions are made. At least in principle, better decisions can be made.

These considerations lead to the conclusion that if ETAM were not developed and used, something much like it would have to come about within the next decade. Unfortunately, computer specialists and enthusiasts generally attempt to devise a universal and self-sufficient automatic formula which excludes convenient human intervention and participation with the process. When this approach is shown to fail, as it inevitably does, the resulting cynicism delays sponsorship for a more sensible iteration on the problem.

Even without further work in the indexing and linking of Navy data bases or in the computerization of procedures, ETAM should serve as a useful tool. Each of the eight tasks in the procedure can be performed manually. Informed estimates may have to take the place of greatly dispersed sources of hard data. Specific programs may be written, or adapted, for the calculational operations. The files may consist of paper documents rather than electronic store. These will dilute the efficiency intended for ETAM but sustain its central principles and objectives to bring the largest amount of relevant data feasible to the decision process, and to make data and process explicit.

The range-of-effect section may be treated as a formal and comprehensive structuring of educational and training technology, and therefore a contribution in its own right. The whole of training, and the training enterprise, may be seen as an orderly pattern of constituent parts and objectives. Needs and solutions may be perceived in large contexts.

In the sense of the ETAM task sequence, data structures, and external file disciplines, ETAM has been "completely" described. In terms of implementation in terms of computerized aids and efficiencies, it has achieved limited realization with limited means. In terms of cost-effective testing under whatever realistic conditions turn out to be feasible, it stands only on the threshold.

REMAINING PROBLEMS. The following are some key problems that affect the implementation and acceptance of ETAM. (The reader may notice that some of these problems reflect topics in ETAM Task 3.)

Indexing the Data Bases. Only a sample of training courses, job-tasks, and instructional devices have been indexed, and only one person performed the task. At a conservative estimate, two persons with equivalent skills could index the entire present inventory of job-tasks in the Occupational Standards, the courses in CANTRAC, and the instructional devices. The application of the descriptors to the Range-of-Effect task remains to be performed so that the reliability of the entities obtained during a search can be determined. This empirical process should be performed following a more extensive incorporation of indexed entities into the ETAM Abbreviated Data Bases.

Fine-Tuning the Procedures. Only rather rudimentary work on the procedural interface between computer functions and human users will have been completed by the termination of this phase of the project; and the typewriter-like terminal, as contrasted with a graphic CRT display terminal, is merely an expedient stop-gap device for demonstrating feasibility rather than interactive effectiveness. The training and tutoring of the assessor at the terminal have not been worked out, nor have the all-important procedures for invoking relevant tutorial networks on-line. Not only ease of use, but "pleasure in use" is essential to continued acceptance of the interface, and of the procedures implicit in the interface. Another key factor will be the performance requirements of the machine as manifest in its delays in responding to commands and requests by the user, especially in data searches and retrievals. Delays of more than a very few seconds can radically alter the level of aspiration the user adopts for task performance; hence, for the task itself. The interface design is therefore a complex of system tradeoff decisions and inventions. These require formulation and testing.

Training of Assessors. It remains to be seen whether individuals can be suitably selected and trained in the knowledge and disciplines of the assessor role in ETAM procedures. In the field of training, as in others, people tend to become specialists and prefer the well-identified role of specialized expertise. The assessor must be an "operational generalist," one familiar with the workings of a broad range of subject matter and able to cope with the complexity of diversity and able to be comfortable with ambiguity and imprecision as known to the specialist. It is unclear that even a very small number of such individuals can be found and justified as well as qualified for this job.

Acceptance by Decision-Makers. The underlying rationales in ETAM are order, consistency and explicitness in decision data. Many executives may feel threatened by these factors, and especially the last-named. The explicit documentation may conceivably make them vulnerable to their competitive peers or to their higher command levels. The high degree of order in ETAM data and its formal retrieval structures may shift the executive's competence from mere dependence on the output of trusted staff to evaluation of constituent judgments by his staff. This, in turn, may imply a higher level of operating knowledge about the workings of the enterprise than the executive may feel he has. Any one or all of these factors, added to novelty in operation, could result in resistance from those whom the function is intended to serve.

Training Development Innovations. The ETAM Range-of-Effect topics included operations in the design and development of training content: description of system requirements, task requirements, selection of instructional devices, development of training content, and so on. These were acknowledged as a special class of problems for decisions about innovations. An originally proposed ETAM study and development task was targeted at the Training Development and Administrative functions. This was not undertaken in the current ETAM effort. It would have refined the evaluation of the effects of an innovation upon the job/tasks associated with the spectrum of training development and administrative function. Controversies about "Instructional Systems Development" give evidence that these are not a trivial class of problems for which innovations are important. This entire topic needs to be brought out and given more sophisticated attention in terms of benefit-cost analysis.

RECOMMENDATIONS

ETAM has been designed procedurally and certain components are computerized. It still requires technical nurturing and, perhaps more important for survival, promotion for acceptance both as a concept and as an operational entity. It is essential that it be integrated as an operational concept into the decision-making process for assessing innovation and change.

It is recommended that the existing Range-of-Effect descriptors be carefully evaluated using training and training research professionals who are familiar with the content and intent of training programs, and who have thoroughly familiarized themselves with the taxonomic structures outlined in Appendix A of this report. The existing sample of entities in the Abbreviated Data Bases can be used initially, however, familiarity with the descriptors can best be gained by indexing and storing additional items in the data base. This indexing of entities is intended to have its primary value in the ETAM application, however, the structure lends itself to additional investigations by training and personnel researchers into the profiles of courses, instructional vehicles, and job/tasks used within the Navy. This understanding should lead to more specific efforts to improve these functions.

The decision analysis and financial analysis function within ETAM provide a strong analytic capability for assessment of innovations. The decision tree permits outcome utilities to be evaluated based upon a "maximization of expected value" decision rule. This would appear to be the most appropriate rule for the majority of changes introduced into the training system. However, considering

TAEG REPORT NO. 40

the Navy's mission and the possibility of major risks to the performance of that mission by introducing a significant functional change to training; e.g., conversion of a high number of technical courses to OJT, other decision rules such as "minimization of expected loss" should be considered. Scenarios should be developed and tested using the presently designed assessment procedures.

Another aspect of the decision tree structure that should be given further study is the means by which risk reduction projects are selected and grouped. Optimization techniques may be applicable for deciding on the most appropriate groupings for maximizing the decision variable.

INTRODUCTION OF CHANGE AGENT. The single most important action that the sponsoring agency could take would be the appointment of an activist change agent whose roles and responsibilities would be much like those described for the change agent in Chapter XIII of the Major Innovations in Training Technology report. Its future stages of maturation will depend not on sponsoring agency relationships with designers and developers, but on personnel roles and responsibilities within the Navy. The individual or team selected should have proprietary motivations and incentives.

The change agent should reside in an organization that gives him mobility and permanence. He needs mobility for access to the variety of Navy agencies that generate data base input to ETAM, and to agencies that can be guided by various ETAM functions. The change agent can then serve the advisory roles so important to the promotion of even limited adoptions. And the network of organizational dependencies can be strengthened as well as articulated.

Promotional skills and initiatives must be supplemented with sound technical expertise, and both of these tempered with optimistic realism. The technical expertise includes a grasp of ETAM principles and philosophies as well as its practices and extends into Navy training operations and its realities, both technical and organizational.

PAPER WALK-THROUGHS OF ETAM. Two or three samples of real problems concerning decisions about long-term changes in Navy training policy or practice or equipment should be selected for trial runs of ETAM. Several individuals, at least tentatively supportive of ETAM concepts, on the sponsoring agency's staff should conduct a walk-through simulation of the eight steps in the procedure. The results should be far more convincing than sample exercises conducted by the design team. The value of such extensions of present ETAM status as range-of-effect indexing and fully interactive supports can then be reassessed with an empirical reference.

GRAPHIC DISPLAY TERMINALS. Ultimately, a tool such as ETAM should interface with the assessor through a graphic CRT type terminal, rather than the existing printer terminal. This is seen as the key to successful interaction between assessors, executives and ETAM procedures. Such a terminal makes feasible the use of the computer as a training and guidance capability, and an effective basis for working with data base content. The thirty characters per second output, limited to alphanumerics, of the terminal station is too limited for much more than limited demonstrations of feasibility. The light pen or cursor coupled with dynamic menus of commands and instant tutorials and guidance messages would dramatically change the psychological nature of the procedures. Ease of use, flexibility and convenience would increase, perhaps by an order of magnitude.

AD-A041 217

IBM CORP CAPE CANAVERAL FLA
DESIGN OF TRAINING SYSTEMS. COMPUTERIZATION OF THE EDUCATIONAL --ETC(U)
MAY 77 L R DUFFY, R B MILLER, J D STALEY N61339-73-C-0097
TAEG-40-VOL-1

F/G 5/1

NL

UNCLASSIFIED

3 OF 3

AD
A041217



END

DATE
FILMED
7-77

TAEG REPORT NO. 40

The development of these interactive capabilities could be made to serve purposes broader than those of formal ETAM. Cost analysis and sensitivity analysis (Tasks 4 and 6 in ETAM) have a broader application base. So does the financial analysis capability (Task 7).

If this recommendation is followed, the design and development of the interactive capability should have a strong control from human factors expertise on the programming effort.

INTERACTIVE ETAM TRAINING PROGRAM. The content for training and guiding the ETAM assessor staff and executive users already exists in the text of ETAM documents--the Phase II-A report and the reports on scaling and indexing, and the innovations in training report. The content of these documents is also appropriately indexed according to steps and considerations in the ETAM procedures. The availability of a graphic display terminal is seen as a means to facilitate a "learn by doing" approach to improving the assessors' ability to interact with the ETAM procedures. The speed of the present printer terminal precludes effective application of training content integrated into the ETAM computerized process. The availability of a higher speed graphic display terminal would permit the training in ETAM to be threaded on sample problems with realistic contents.

It is also tentatively suggested that the ETAM training material might be used more widely. It could provide a general working knowledge of instructional technology relatively painlessly to a wide spectrum of specialists and managers in the Navy's training and education operations. Hopefully, this enlightenment could not only widen the perspective of specialists but also increase the enlightened cooperation among agencies that tend to develop rivalries.

LINKED NAVY DATA BASES. The range-of-effect task and the cost and financial analysis tasks in ETAM point to the profound need for shared disciplines in accessing the content from large Navy data bases that are scattered among different organizations. The key to making these data bases into problem-solving networks is a categorical discipline--the selection and meaning given to the terms that index data elements. Only by a shared taxonomic discipline can one data base "talk" to another, and share data constituents in arriving at non-local decisions.

The need for multipurpose data comes to a focus in ETAM determinations of range-of-effect and in cost analysis. In most cases, human judgment (hopefully informed) is the link between the ETAM problem and external data bases on courses, student attributes, job-tasks, cost breakdowns, and instructional equipment. This link can be expensive, time-consuming and, contingent in part on imprecise or ambiguous source data, unreliable.

Two courses are open. One is to determine what is the best that can be done with existing data sources and structures. The other is to attempt at least compromise improvements in getting the source to better match the need. These are not, of course, mutually exclusive alternatives. A single agency is unlikely to be able to directly affect data base disciplines in a broad span of organizations. But if ETAM becomes adopted as a rational technique for making decisions about any of a broad range of change in policy and practice of Navy training, it can become a common denominator definition of data support requirements. It may therefore serve as one major reference for data base standardizations.

TAEG REPORT NO. 40

ETAM was designed to accept and use whatever data come in to it, including gross estimates as well as guesses. This is both a power and a liability. The power is in getting a job done, a decision made; even though the source data are weak, the best that can be made of weak data is done with it. It has built-in expressions for weakness in data confidence ranges and limits expressed by the assessor to the decision maker in several ways. But the liability is that despite expressions of low confidence in source data, the formalism implied by "models" and "computerization" can create an atmosphere of spurious rightness of content. This liability is not peculiar to ETAM--it applies to any form of computerization. The awareness merely increases the ethical responsibility for system designers to strive for legitimate information input.

This is a general comment without a specific focus. Ambiguity and uncertainty are inevitable in all real life operations, and it is unrealistic to expect otherwise. Decisions will continue to be made under massive uncertainties. ETAM has attempted to reduce uncertainty partly by structuring it through showing what variables are relevant to the decision, partly by processing whatever data can be expressed towards solutions. Further improvements in the quality of decisions will have to come from the quality of input data.

FUTURE DEVELOPMENTS. The content of ETAM is specific to education and training technology and operations. The structure, as represented by the eight procedural tasks and their constituent procedures, is a completely general one for arriving at and making decisions that affect changes in an enterprise and what it does.

It is anticipated that this generality of procedural structure for arriving at rational decisions--even in non-rational contexts--can be recognized and translated widely into other technical and organizational environments. It is recognized that many organizations now use cost models and financial planning models; a few even apply some form of utility scaling in formulating decision models. But it is suspected that what in ETAM are Tasks 1 through 5 are not tackled formally, so that the latter tasks work from limited and often unexplored data sources that are essential to sound decision making. Nor is the decision maker enabled quickly--such as within the hour's presentation and study--to sample selectively into the background data and judgments leading to the final chart of "conclusions." It is the limited time and span of attention of the executive who makes the choice of commitment that largely justifies the quality of the assessing staff work.

If these anticipations come about, ETAM itself will have served a change agent function.

DISTRIBUTION LIST

Air Force

Headquarters, Air Training Command (XPTD, Dr. D. E. Meyer)
Headquarters, Air Training Command (XPTIA, Mr. Goldman)
Air Force Human Resources Laboratory, Brooks Air Force Base
Air Force Human Resources Laboratory (Library), Lowry Air Force Base
Air Force Office of Scientific Research/AR (Dr. A. R. Fregly)

Army

Commandant, TRADOC (Technical Library)
Army Research Institute (Dr. Ralph R. Canter, 316C; Dr. Edgar Johnson)

Coast Guard

Commandant, U.S. Coast Guard Headquarters (G-P-1/62; G-RT/81)

Marine Corps

CMC (Code OT)
CGMCDEC (Mr. Greenup)
Director, Marine Corps Institute

Navy

Assistant Secretary of the Navy (R&D) (4E741, Dr. S. Koslov)
CNO (OP-987P7, CAPT Connery; OP-991B, M. Malehorn; OP-987P10, Dr. R. Smith;
OP-987, H. Stone)
NAVCOMPT (Code NCD-7)
ONR (Code 458, 455)
ONRBO Boston (J. Lester)
ONRBO Chicago
ONRBO Pasadena (E. E. Gloye)
CNM (MAT-03424, Mr. A. L. Rubinstein)
CNET (01, 00A, N-5 (6 copies))
CNAVRES (Code 02)
COMNAVSEASYSKOM (03, 047C1, 047C12)
COMNAVAIRSYSKOM (03, 340F)
CNET SUPPORT (00, 01A)
CNTECHTRA (0161, Dr. Kerr (5 copies))
CNATRA (F. Schufletowski)
COMTRALANT
COMTRALANT (Educational Advisor)
COMTRAPAC

DISTRIBUTION LIST (continued)

Navy (continued)

CO NAVPERSRANDCEN (Code 02, Dr. Regan; Dr. Earl Jones; Library)
NAVPERSRANDCEN Liaison (Code 01H)
Superintendent NAVPGSCOL (Code 2124)
Superintendent Naval Academy Annapolis (Chairman, Behavioral Science Dept.)
CO NAVEDTRAPRODEVEN (AH3)
CO NAVEDTRASUPPCEN NORVA
CO NAVEDTRASUPPCENPAC (5 copies)
CO NAVAEROMEDRSCHLAB (Chief Aviation Psych. Div.)
CO FLTCOMDIRSYSTRACENPAC
CO NAMTRAGRU
CISO, NTTC Corry Station
CO NAVTRAEQUIPCEN (N-21, N-215, N-131 (2 copies), N-2211, N-00AF, N-00M, PM TRADE)
Center for Naval Analyses (2 copies)
U.S. Naval Institute (CDR Bowler)

Other DOD

Military Assistant for Human Resources, OAD (E&LS) ODDR&E (COL Henry Taylor)
OASD (I&L) - WR (LT COL Grosse)
Director, Human Resources Office, Defense Advanced Research Projects Agency
(R. Young)
Defense Advanced Research Projects Agency (CTO, Dr. H. F. O'Neil, Jr.)
Institute for Defense Analyses (Dr. Jesse Orlansky)

Non-DOD

Essex Corporation (Dr. John Collins)

Information Exchanges

DDC (12 copies)
DLSIE (James Dowling)
Scientific Technical Information Office, NASA
Executive Editor, Psychological Abstracts, American Psychological Association
ERIC Processing and Reference Facility, Bethesda, MD (2 copies)