

AD-A041 323

MASSACHUSETTS INST OF TECH LEXINGTON LINCOLN LAB
SATELLITE-TO-SATELLITE DATA TRANSFER AND CONTROL (U)
JAN 77 D M SNIDER, D B COOMBER

F/G 17/2

UNCLASSIFIED

TN-1977-4

ESD-TR-77-25

F19628-76-C-0002

NL

1 OF 1
ADA
041323

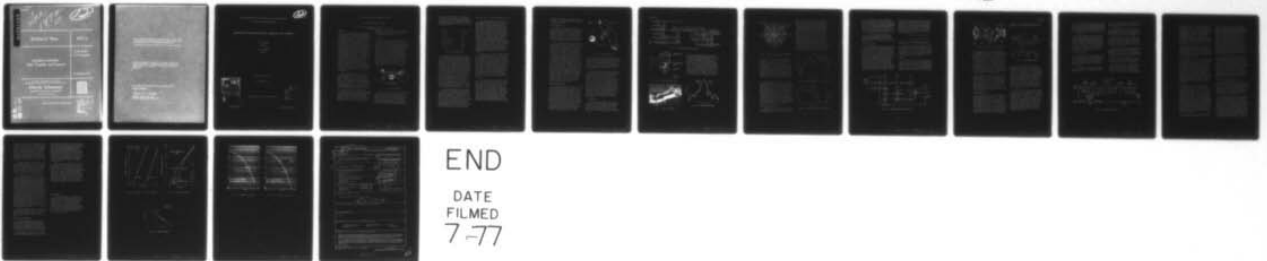

END

DATE
FILMED
7-77

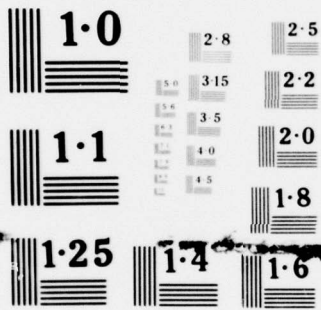

NATIONAL BUREAU OF STANDARDS
MICROCOPY RESOLUTION TEST CHART

ADA 041323

See 1475

12

Technical Note

1977-4

Satellite-to-Satellite
Data Transfer and Control

D. M. Snider
D. B. Coomber

19 January 1977

Prepared for the Department of the Air Force
under Electronic Systems Division Contract F19628-76-C-0002 by

Lincoln Laboratory

MASSACHUSETTS INSTITUTE OF TECHNOLOGY

LEXINGTON, MASSACHUSETTS



Approved for public release; distribution unlimited.

AD No. —
DDC FILE COPY

DDDC
RECEIVED
JUL 7 1977
REGISTRATION
D

The work reported in this document was performed at Lincoln Laboratory, a center for research operated by Massachusetts Institute of Technology, with the support of the Department of the Air Force under Contract F19628-76-C-0002.

This report may be reproduced to satisfy needs of U.S. Government agencies.

The views and conclusions contained in this document are those of the contractor and should not be interpreted as necessarily representing the official policies, either expressed or implied, of the United States Government.

This technical report has been reviewed and is approved for publication.

FOR THE COMMANDER

Raymond L. Loisel

Raymond L. Loisel, Lt. Col., USAF
Chief, ESD Lincoln Laboratory Project Office

12

MASSACHUSETTS INSTITUTE OF TECHNOLOGY
LINCOLN LABORATORY

SATELLITE-TO-SATELLITE DATA TRANSFER AND CONTROL

D. M. SNIDER

Group 68

D. B. COOMBER

Group 69

TECHNICAL NOTE 1977-4

19 JANUARY 1977

ACCESSION BY	
NTIS	Write Section <input checked="" type="checkbox"/>
DDI	Copy Section <input type="checkbox"/>
UNANNOUNCED	<input type="checkbox"/>
JUSTIFICATION	
BY	
DISTRIBUTION/AVAILABILITY CODES	
Dist.	APRIL 1977/SPECIAL
A	

Approved for public release; distribution unlimited.

DDC
RECEIVED
JUL 7
RECEIVED
D

LEXINGTON

MASSACHUSETTS

SATELLITE-TO-SATELLITE DATA TRANSFER AND CONTROL

DAVID M. SNIDER and DAVID B. COOMBER

Lincoln Laboratory, Massachusetts Institute of Technology
Lexington, Massachusetts

ABSTRACT

The LES-8 and -9 satellites are three-axis stabilized earth-orbit spacecraft which provide communications at UHF and K-band frequencies with the capability of simultaneously establishing and automatically maintaining a K-band (36-38 GHz) satellite-to-satellite data link. Narrow beam (1 deg) antennas are used which incorporate flat reflecting plates for beam pointing in such a way that slip rings or waveguide rotary joints are not required. The antenna beams are electrically lobed by sequentially switching offset feedhorns to produce error signals for autotracking. Spatial acquisition is accomplished by a digital pointing control which scans the spatial uncertainty while an autotrack receiver eliminates frequency offsets and doppler. Link acquisition is accomplished when the antenna boresights are aligned and the received signals are in the receiver passbands. The link can support a data rate of 10 or 100 kb/s, depending on satellite separation, while maintaining antenna beam alignment of 0.04 degrees. Differences in spacecraft timing and doppler effects are accommodated by an "elastic" shift register which inserts a variable delay to allow synchronization of the crosslink frame to the nominal downlink frame so that simple time-multiplexing will yield a downlink containing both crosslink and uplink data streams.

The inter-satellite data "crosslink" extends the earth coverage over that which a single satellite can provide and demonstrates how a global communications system might be realized without the restrictions imposed by ground relay. Crosslink antenna pointing angles have been used as a reference for the Attitude Control system to maintain satellite spatial orientation without any earth references. The link also includes capability to relay Command and Telemetry so that control of a spacecraft not nominally in range of any ground station is achieved.

The paper describes the operation and characteristics of the lobing antenna and pointing control, the solid state transmitters and receivers, the autotrack receiver and elastic shift register. Ground based and post-launch test results of pointing and communication systems are presented. Also, a user-oriented system is described which, among other features, allows an

operator to easily establish crosslink from the ground terminal using pointing angles calculated by a small computer using spacecraft derived earth pointing parameters.

INTRODUCTION

The LES-8 and -9 satellites are three axis stabilized spacecraft which were placed into geosynchronous orbit on March 14, 1976. Each satellite provides earth communications in the military UHF band through a 10-dB gain dipole array and at K-band (37 GHz) through a 25-dB gain horn antenna. Both spacecraft are also capable of simultaneously establishing and automatically maintaining a K-band satellite-to-satellite data link. The inter-satellite data "crosslink" extends the earth coverage over that which a single spacecraft can provide by allowing the retransmission of information initially received by one satellite on the downlink of the other satellite. The crosslink can support a data rate of 2.4 to 100 Kb/s while providing earth coverage for the up and downlinks determined by the UHF and K-horn antenna beamwidths and the satellite-to-satellite central separation angle of up to 100 degrees (see Fig. 1).

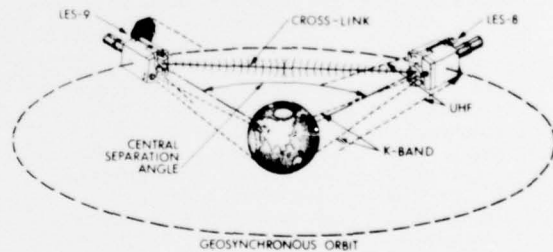

Figure 1. ANTENNA COVERAGE

Each spacecraft employs solid state components in redundant configurations wherever possible to enhance satellite reliability and lifetime. In keeping with this philosophy, four silicon Impatt diodes are combined in the output of the K-band crosslink transmitters to reliably generate 0.5watt BPSK modulated signal. The crosslink receivers each incorporate two gallium arsenide diodes in a balanced mixer design which provides

a 7-dB front-end noise figure. The desired satellite-to-satellite data rate of 100 Kbps together with the available transmitter output power and receiver noise figure dictate crosslink antenna gains of about 42-dB for a satellite-to-satellite separation of 40,000 km. (See Link Calculation, Fig. 2)

Required E_b/N_0	=	10 db (BER = 10^{-6})
Desired data rate	=	100 Kbps (50 dB-Hz)
Required P_r/N_0	=	60 dB-Hz
Available transmitter $P_0(f)$	=	+28 dbm
Tx filter and polarizer losses	=	-2 db
Path Loss (40,000 Km, 37 GHz)	=	-216 db
Rx filter and polarizer losses	=	-1 db
K.T.N.F. (noise figure = 7 db)	=	-167 dbm-Hz
Resulting P_r/N_0	=	-24 dB-Hz
Required antenna gain (60 + 24)	=	84 dbI

Figure 2. LINK CALCULATION

The antenna gain is provided by a pair of 18-inch parabolic dishes (one per spacecraft) but the resulting narrow beamwidths (1 degree) require the alignment of the antenna boresights along the line of sight between the spacecraft. Antenna pointing is provided by controlling the orientation of flat reflecting plates to redirect the beams. This technique has the advantage that no rf rotary joints are needed. The plates are supported by elevation over azimuth positioners which incorporate integral resolvers that have been aligned to the satellite physical axes so that the antenna beams can be pre-pointed in any desired direction over a range of ± 10 degrees in elevation and ± 52 degrees azimuth. Brushless dc tachometers and torque motors are used in conjunction with wire crossovers to provide damping and pointing torque without resorting to slip rings. The pointing control also accepts pointing error signals produced by electrically lobed feedhorns and autotrack receivers such that link acquisition is assured if the antenna boresights are within 0.7 degrees of each other and the boresight $P_r/N_0 > 46$ dB.

If the antenna boresights are not within 0.7 degrees of each other the pointing controls have available (by Command) a SCAN mode whereby the antenna beams are automatically stepped over a spatial uncertainty of 2.1 degrees x 3.5 degrees in 0.7 degree steps while the autotrack receivers sweep a frequency uncertainty of ± 5 KHz. The spatial scan range was sized to overcome the 3σ uncertainty in pointing direction due to tolerances in attitude control, orbit fit and spacecraft structural deflections while the frequency sweep accommodates doppler and crystal oscillator drift. Our post-launch experience has been that pre-acquisition pointing angles

are usually within 0.5 degrees of antenna boresight.

Due to the many modes of LES-8/9 and the large number of potential users, the basic timing was selected to run off real time, or UTC, so that uplink and downlink synchronization for several modes can be achieved with only a knowledge of UTC. The reception of crosslink data from another satellite is therefore complicated because the instantaneous data rate over the crosslink will, in general, be slightly different from the downlink data rate of that same satellite due to the variable satellite-to-satellite separation. To overcome this basic difficulty we have employed an elastic shift register (ESR) which is a variable length buffer capable of slightly different input and output rates. Provision is made for the long-term effect of higher or lower relative clock rates at input and output by allowing the ESR to delete or repeat frames of 50 bits. Using entire 50-bit frames avoids disturbing the frame sync in the ground terminals, while in addition, 1 second warning is given of an impending frame deletion or repetition by modification of a communications sync code and by Telemetry.

The synchronizer following the ESR establishes where to tap the buffer so that a crosslink frame will coincide with a downlink frame to allow easily demodulated TDM. In its acquisition mode, the synchronizer tests subsequent bit positions for fewer than 7 frame sync failures in 32 frames. Achieving this at some point, the monitor mode is entered which must find fewer than 103 out of 256 possible frame sync failures to maintain this tap position. Average time to acquire frame sync at 100 kb/s is 0.18 msec. After frame sync is established, the system must acquire parity sync on the low rate (200 bps) data multiplexed into the crosslink so that telemetry and low rate uplink data received by the other satellite is successfully routed to the 8-ary UHF downlink. Worst case acquisition time for this mode is about 10 seconds.

In view of the complex nature of the crosslink communications system on LES-8/9, a comprehensive, yet manageable, control center for these functions was a logical result of a desire to fully understand and exercise the various satellite links. This has been realized by integrating the Command and Telemetry systems into a set of display panels which show the configuration of the communications modes of each satellite, indicating binary switch positions, signal levels at various points in dB, real time clock monitoring, dish pointing angles, attitude control corrections, and similar functions. An integral part of the display panels is the command generator which has push buttons and data switches located on the panel adjacent to related

telemetry. Key guarding is provided to prevent unauthorized commanding and the command generator is designed so that only communications-related commands can be output.

SPATIAL ACQUISITION

In order to establish the satellite-to-satellite crosslink, both satellite antenna boresights must first be simultaneously brought to within 0.35 degrees of the line of sight (LOS) between the spacecraft so that spatial pull-in can occur. Simultaneity is a requirement since each spacecraft is the beacon for the other to pull-in and track on. Once spatial acquisition has been accomplished, the full antenna gain is available to enhance frequency acquisition.

The cartoon shown in Figure (3) depicts how the spatial and frequency uncertainties are resolved automatically. The satellites are shown with antenna beams pre-pointed to lie along the calculated LOS. Tolerances on orbit fit, Attitude Control and deformation of the satellite structure due to thermal and "zero-G" stress total to about ± 1 degree so that these initial pre-point angles can be in error by that amount. To overcome these errors, the satellites are commanded to begin incrementally searching a 2.1×3.5 degree area centered about the direction of best available information in 0.7 degree-steps. The spatial scans of both spacecraft are not synchronized so that one spacecraft scans at a rate sixteen times slower than the other to allow the fast scan satellite to complete its 15 position scan before the slow scan satellite increments to a new position. The fast scan spacecraft takes 0.5 seconds to reach a new pointing position and maintains that direction for 2.3 seconds. In this way adequate time is provided for the receivers to sweep the full frequency uncertainty without synchronizing the frequency sweeps to either spatial scan. Should the boresight P/N_0 degrade, both spacecraft can be scanned at half the normal rate (by Command) allowing time for two frequency sweeps with a resulting improvement in the probability of spatial and frequency acquisition.

CROSSLINK BLOCK DIAGRAM

A simplified functional block diagram of the crosslink system is presented in Figure (4). The required transmit/receive antenna gain is provided by an 18-inch parabolic reflector illuminated by a circular-polarized feedhorn. The beam is electronically "squinted" 0.07 degrees by sequentially energizing pairs of bi-phase modulators which are connected to offset feeds that have 20 dB coupling to the main feed. The beam squinting impresses amplitude modulation on the K-band received signal for sources off boresight. After mixing down to IF (3 MHz) an AGC amplifier normalizes the AM waveform so that variations in signal level due to the antenna pattern and crosslink range are eliminated. The AM signal is then bandpass filtered and detected in synchronism with the modulator drivers to produce azimuth and elevation error signals. These

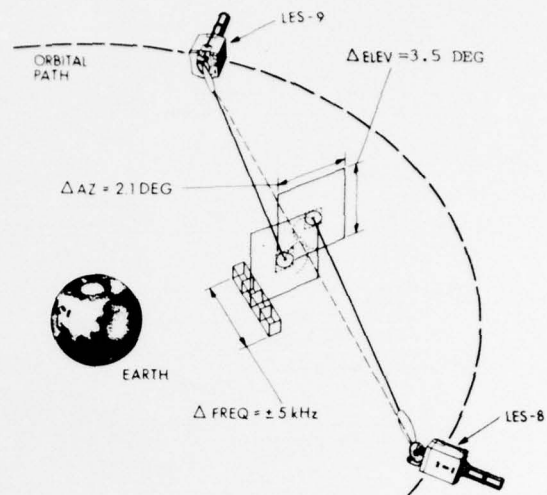

Figure 3. SPATIAL ACQUISITION

signals are used in a closed loop fashion with the signal from the other spacecraft as a reference to provide satellite-to-satellite autotracking. Amplitude modulation of the transmit signal caused by bi-phase modulator effects at the transmit frequency is indistinguishable from real mispointing and is eliminated by including notch (band-stop) filters between the bi-phase modulators and the offset feeds.

The antenna pointing direction is controlled by the position of a flat reflecting plate placed in front of the parabolic dish to re-direct the focused beam (Fig. 5). The flat reflector is mounted to a gearless bi-axial drive which utilizes resolvers as a reference in the pointing control feedback loop to pre-point the antenna. Shaft torque and damping are provided by brushless dc servomotors and tachometers while an azimuth axis wire cross-over eliminates the need for slip rings. Since the antenna feed network does not rotate with the reflecting plate, the lobing axes change with plate orientation so that the pointing error signals must be put through a coordinate rotation to realign the electrical lobing axes with the non-rotating feed axes. The functions of error signal electronic rotation, beam pre-pointing, spatial scan control and autotracking are all provided by the Pointing/Scan control.

Lobing Feed

The five horn feed assembly is shown in Fig. (6). The mechanical support and alignment mechanism utilizes slant and slotted ways to adjust the feed horn assembly to within ± 0.002 inches laterally and ± 0.10 degrees angularly. The center feed design incorporates a crossed septum which increases the lobing error slope by increas-

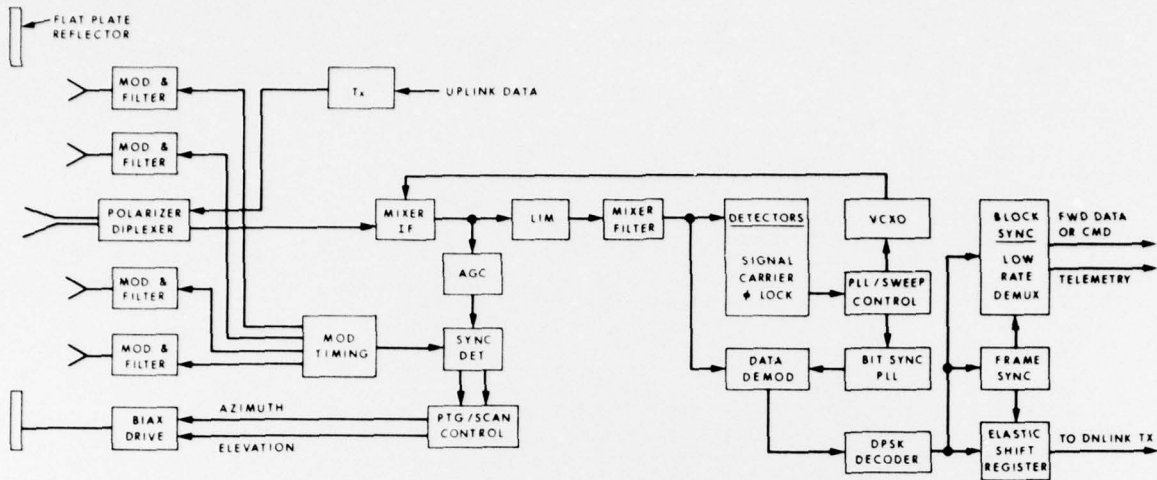

Figure 4. CROSSLINK SYSTEM BLOCK DIAGRAM

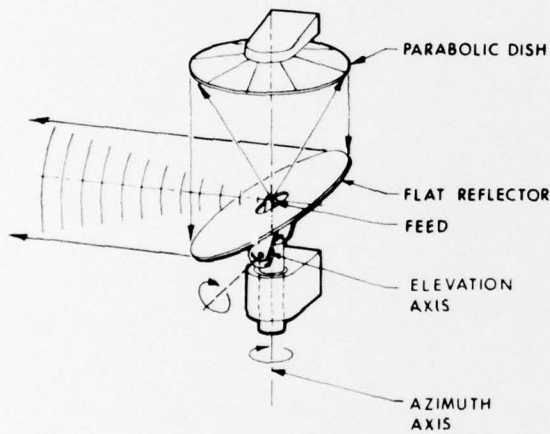

Figure 5. CROSSLINK ANTENNA SYSTEM

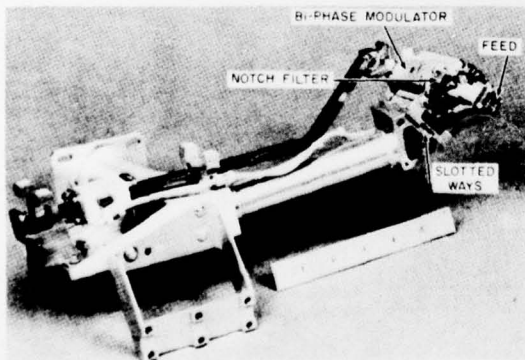

Figure 6. LOBING FEED ASSEMBLY

ing the coupling between the main and offset feeds without reducing the antenna efficiency. The bi-phase modulators require 65 ma at 3 volts to provide 180 degrees RF phase shift and are driven by 100 Hz square waves shifted by 90 degrees to each other such that 360 degrees of antenna lobing occurs in four steps at a 100 Hz rate. The effect of energizing the phase modulators is shown clearly in the antenna patterns in Fig. (7). Here opposite pairs of modulators have been energized prior to recording a pure azimuth pattern with a resulting "squint" in the pattern of about ± 0.07 degrees. The antenna lobing characteristics are presented in Fig. (8). The concentric lines are contours of constant

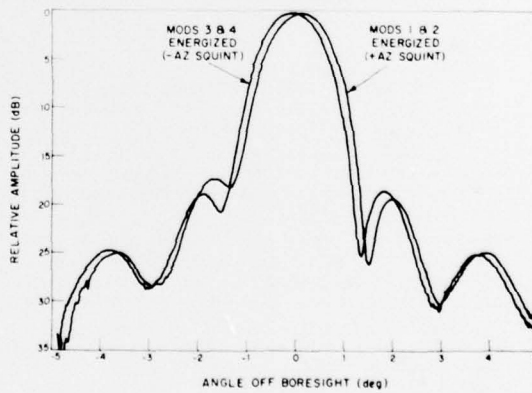

Figure 7. LOBED ANTENNA PATTERNS

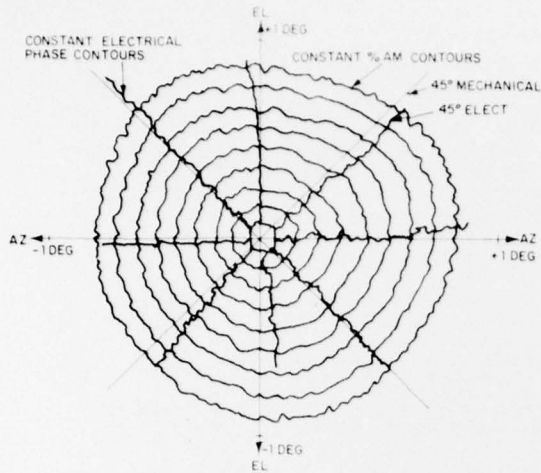

Figure 8. LOBING SENSITIVITY AND ORTHOGONALITY

percentage AM and show the variation in lobing sensitivity to be less than ± 10 percent within one degree of boresight. The radial lines are contours of constant AM phase and show the electrical lobing axes to be within ten degrees of orthogonality. Reducing these imperfections to be within the total autotrack amplitude and phase variation stability budget of ± 50 percent and ± 40 degrees requires the axial ratio of each feed to be fine-tuned to better than 0.8 dB. In addition, ferrite isolators are required in the waveguide runs leading to the transmitter and receiver so that any reflection from the diplexer bandpass filters will not upset the axial ratio.

The K-Band receiver consists of a two diode balanced mixer followed by a 2 GHz transistor amplifier providing a 7 dB front end noise figure. In order to minimize waveguide and circuit losses and reduce the probability of radiative interference, the receiver is built as an integrated mechanical unit physically attached to the antenna feed assembly. After frequency conversion to 3 MHz, the signal is passed through an attenuator which eliminates the possibility of sidelobe acquisition by reducing the signal-to-noise ratio at IF due to sidelobe radiation below the S/N required to spatially pull-in. The attenuator is adjustable by Command, prior to spatial acquisition, in 5 dB steps over a 75 dB range such that boresight autotracking is assured for any central separation angle greater than 1 degree.

CROSSLINK AUTOTRACK RECEIVER

The input to the autotrack receiver is a DPSK modulated 3 MHz signal from the step attenuator which also contains satellite to satellite

autotrack pointing information in the AM impressed upon it by the lobing feed. An AGC amplifier is employed to eliminate variations in received signal level without affecting the percentage AM so that the resulting waveform at the AGC output is linearly proportional to angle off boresight. In order to stay within the allowable pointing system inter-axis cross-coupling, the AGC was carefully tailored to introduce a minimum phase shift to the 100 Hz tracking signal due to changes in input levels (AM to PM conversion) while still providing the required 55 dB dynamic range and 350 dB/sec rate to accommodate the antenna characteristics during spatial pull-in and tracking. The measured effects of the AGC amplifier on the amplitude and phase shift of the 100 Hz pointing signal is shown in Fig. (9). The total servo amplitude and phase response of the entire crosslink autotrack receiver, including the pre-synchronous detector 100 Hz bandpass filters and post-detector 3.5 Hz low-pass filters and dc amplifiers is shown in Fig. (10). Interpretation of Figs. (9) and (10) is significant

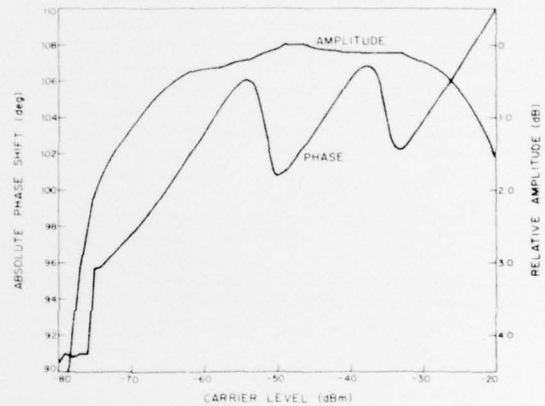

Figure 9. AMPLITUDE AND PHASE SHIFT OF 100 Hz MODULATION

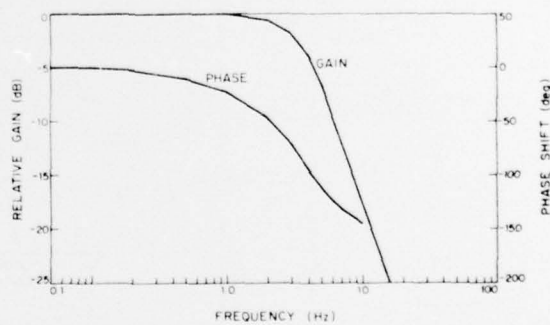

Figure 10. SERVO AMPLITUDE AND PHASE RESPONSE

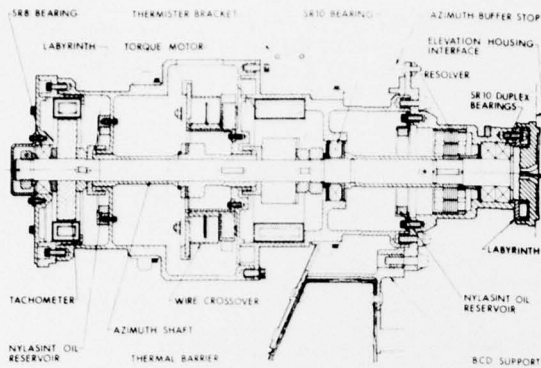

Figure 12. CROSS-SECTION AZIMUTH DRIVE

The small clearances associated with the tachometer, torquemotor, resolve and labyrinth require a ball bearing supported Rene steel shaft to provide adequate mechanical stiffness to prevent physical contact of internal parts during launch. The labyrinth is a 0.005 inch gap about one-half inch long which controls the outgassing rate of the ball bearing lubrication. Since this is a direct-drive, low torque system, the drag (torque load) of a wire harness cannot be tolerated. The wire crossover is a thirty-six conductor device which provides electrical connection through the azimuth shaft and to the axis in a low torque fashion. The design and construction of the elevation axis is similar to the azimuth except that a wire crossover is not needed since the angular range is less (10 degrees vs. 104 degrees).

Since the bias assembly is by nature of its function external to the main spacecraft body, a separate thermal control system is required to prevent excessive lubrication depletion by outgassing and to minimize thermally induced component stress. Proportional control heaters maintain body temperature at +10°C during shadow, while thermal radiators are sized to limit the maximum temperature during solar heating to +35°C. Thermal cans and multilayer thermal blankets are utilized extensively to minimize the heater power requirements and radiator size.

SIGNAL ACQUISITION

After spatial acquisition of the crosslink antennas, the crosslink signal must be acquired. The signal between LES-8 and LES-9 is a carrier DPSK modulated at command-selectable rates of either 10 or 100 kb/s. The data format is the same for both rates and timing is synchronized to the on-board real-time-clock. The frame format is described in Fig. (13). The first bit in every frame, always a one, is used for establishing frame synch, to be described later; the second bit is low-rate data which is command-selectable from one of four sources; the third bit is multiplexed between telemetry data and slip/sequence data used in ground monitoring of crosslink sync;

the fourth bit is telemetry data from the crosslink satellite; the remaining 46 bits are user bits.

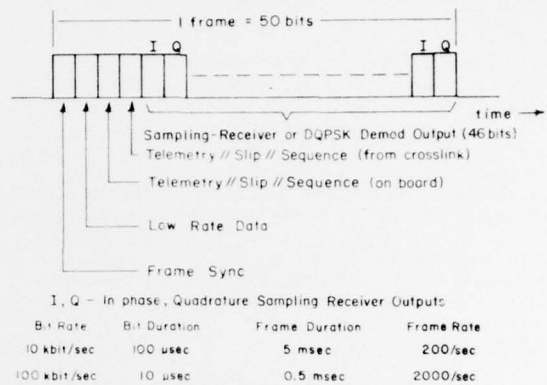

Figure 13. CROSSLINK DATA FORMAT

Frequency uncertainties due to angular separation (one degree per day causes over one kilohertz Doppler shift) and eccentricity (0.01 eccentricity causes almost ±4 kilohertz Doppler shift) are accommodated by a ±5 KHz search range of a 2 GHz voltage-controlled crystal oscillator (VCXO). The resulting 3 MHz IF is limited and mixed down to baseband inphase and quadrature components. The box labelled "DETECTORS" in the block diagram determines the presence of system phase lock, unmodulated signal or modulated carrier. The receiver is closed as a second-order phase-lock loop which holds lock for $P_r/N_o > 38$ dB-Hz. After acquiring frequency and phase, the "BIT SYNC PLL" adjusts bit timing in 1/3 microsecond steps to optimally sample the data matched filters.

Since the first bit in each crosslink frame is a one, frame sync is found by testing successive bit positions for the presence of a predominance of ones in sequential frames. Two modes are used, acquisition and monitor. In the initial acquisition mode, a position is tested in 32 successive frames. If seven or more positions are not ones, the timing slips one bit and testing resumes. Eventually frame acquisition will switch the system into the monitor mode. The system still counts zeroes but will reject the sync point only if more than 102 zeroes are found in 256 consecutive frames. Loss of sync and switching to the acquisition mode uses a criterion almost twice as strict as that for entering the monitor mode.

A block consists of four Low Rate Data bits, noted in Fig. (13), accumulated from four consecutive frames. Block sync is established by identifying the parity bit corresponding to the three previous data bits. The crosslink frame sync process averages 2.3 seconds in the 10 Kb/s mode (0.68 seconds in 100 Kb/s), while block sync takes 5 to 10 seconds.

In order that the data bit stream from the crosslink can be interleaved with the data bit stream from the satellite's own uplink, synchronization requires buffering the crosslink data stream. In addition, the buffering will not be a constant delay due to relative motion of the satellites. Adjustable buffering is provided by an "elastic shift register" into which crosslink data bits are inserted at a time varying rate determined by the crosslink data rate and the crosslink delay, and from which data bits are extracted at the downlink rate.

ELASTIC SHIFT REGISTER

A block diagram of the elastic shift register is shown in Fig. (14). The Up/Down Counter controls which bit of the 64 bit shift register is selected for the Data Output. For example, if the number in the Up/Down Counter is 35, then A35 is selected for the Data Output. Whenever an Input Clock pulse is received, two things happen:

1. The Input Data bit is shifted into Q0 and all other bits in the Shift Register move over one bit, e.g., the information bit stored in Q35 moves to Q36.

2. The Up/Down Counter increases its count by one and causes the selector to move over one bit, e.g., if the selector was selecting Q35, it is now selecting Q36.

It should be apparent that there is no net change in the Data Output as a result of the Input Clock pulse, i.e., as an information bit moves down the Shift Register, the selector moves with it, keeping the Data Output constant.

When an Output Clock pulse is received, it decrements the Up/Down Counter by one and thus causes the selector to move one bit to the left, e.g., if the selector was selecting Q36, it is now selecting Q35, which contains the next information bit. It does not affect any information stores in the Shift Register.

Notice that there is no requirement that the Input and Output Clock Pulses alternate and that, ignoring for the moment the problems of end-runover and time-coincidence of Input and Output Clock pulses, the input and output terminals are completely independent and may be operated asynchronously at different frequencies.

The time-coincidence problem is handled by sending the Input Clock pulse through a special synchronizer which delays it if necessary to avoid coincidence with the Output Clock pulse.

Obviously, if the Input Clock rate exceeds the Output Clock rate, more information will be inserted into the ESR than is extracted and a means of "dumping" the excess information is required. Similarly if the output rate exceeds the input rate, the ESR will be drained of infor-

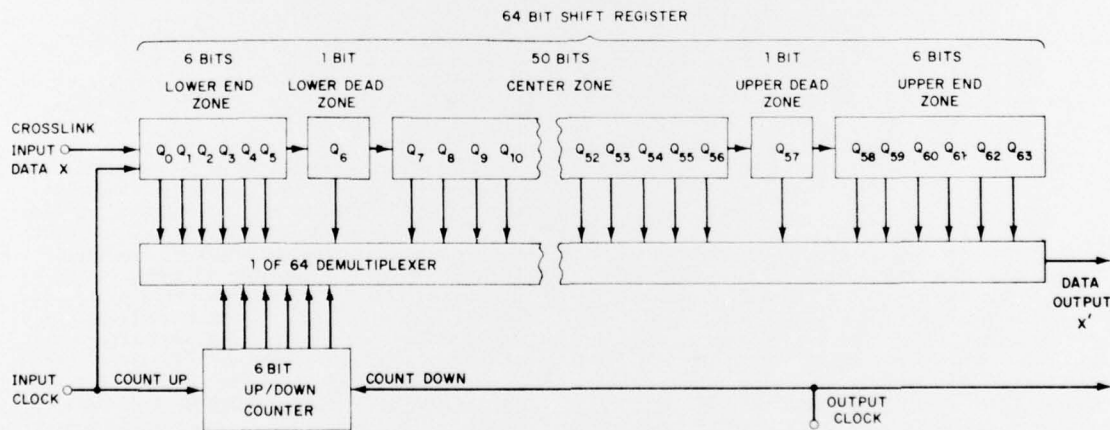

Figure 14. ELASTIC SHIFT REGISTER

mation and a means of "creating" more information is needed. In order to avoid disturbing the frame sync system of ground terminals, entire 50-bit frames are deleted, to effect a "dumping" of information, or repeated, to effect the "creation" of information. A deletion is accomplished by decrementing the Up/Down Counter by 50 which makes the selector skip over 50 bits which are subsequently lost forever. A repetition is accomplished by incrementing the Up/Down Counter by 50 which makes the selector move 50 bits to the right. In this case the selector jumps back over the 50 bits which had been previously output and which will now be output again.

Other system considerations dictate that the ESR give the ground terminals some warning of an impending deletion or repetition. The warning convention adopted is that the ESR will send a delete or repeat warning message through Telemetry and through the third frame for the one-second interval immediately preceding the actual deletion or repetition which occurs on the one-second "tick" of the real time clock.

The 64 bits of the ESR may be conceptually divided up as shown in Fig. (14). If the selector is found pointing to a bit in the upper-end zone at the end of a one-second interval, a delete warning message is initiated and at the end of the one-second warning, the Up/Down Counter is decremented by 50, which moves the selector back to a bit which is, by necessity, in the center zone. Similarly when the selector is found in the lower-end zone, a repeat warning message is initiated after which the Up/Down Counter is incremented by 50, which moves the selector back into the center zone. One bit dead zone is added at either end of the center zone to prevent the ESR from unnecessarily repeating and deleting frames under low-Doppler conditions. Because of the discrete nature of the "BIT SYNC PLL" the crosslink clock is adjusted in 1/3 microsecond increments.

The heart of the ESR control system is a divide-by-50 counter whose count runs from 7 to 56 instead of 0 to 49. This range of number corresponds to the center zone of the ESR. When the system is synchronized, the contents of this counter will indicate the position of the sync bit in the center zone of the ESR (since the center zone has 50 bits, there is always one sync bit in it). Accordingly, this counter operates off the Input Clock, i.e., when an input data is inserted into the ESR, all the bits in the shift register move over one bit, the Up/Down Counter increments by one, and the sync counter increments by one. At one-second intervals the contents of the sync counter are jam loaded into the Up/Down counter. This means that the up/down counter and, consequently, the data selector are forced to select a sync bit at the beginning of a one-second interval, and this also means that the beginning of a frame coincides with the beginning of a one-second interval.

If the ESR was previously operating in the center zone, there is no change in the Up/Down

Counter. If the ESR is in either dead zone the jam loading is inhibited. If a slip warning message has been sent (which implies that the ESR is in an end zone) the jam loading is enabled and the ESR is forced to the center zone. If the system is already synchronized, the ESR is moved from selecting a sync bit in the end zone to a sync bit in the center zone, which is a jump of exactly 50 bits. Thus a slip of 50 bits is achieved via the modulo-50 property of the sync counter--no explicit addition or subtraction of 50 to the contents of the Up/Down Counter is required. If the system is not previously synchronized, the ESR is still forced to a position which represents the sync counter's tentative estimate of where the sync bit is. When the sync counter ultimately achieves synchronization the ESR will also be synchronized at the next one-second tick. Because the ESR is updated only at one-second intervals, the ESR phase telemetry is not an adequate measure of the progress of the system in acquiring sync.

Initially, the sync-counter is adjusted to ultimately contain the position of the sync bit by making it ignore a single clock pulse whenever the sync system concludes that the sync counter does not yet have the correct position of the sync bit. This effectively decrements the sync counter by one, which means that the sync counter's estimate of the position of the sync bit is moved one bit to the left in the ESR, or in other words, it is now trying a bit position which is later in time. When searching for the sync bit, it is preferable to search from early to late so that generally the sync bit is encountered and tested before any of the low-rate bits, which might possibly contain a preponderance of 1's and cause a false sync condition.

MONITORING AND CONTROLLING THE CROSSLINK

Early in the development of LES-8/9 it became apparent that some practical way of keeping track of the various states of the satellites was needed. This was not only apparent with single-satellite tests, but seemed imperative with dual-satellite tests involving the crosslink. A system developed to use the existing command and telemetry links to the satellite soon proved to be indispensable in extensive exercise of the communications subsystems of LES-8/9.

A photograph of the major panel displaying communications command and telemetry is shown in Fig. (15). This panel links a block diagram of the satellite communications system with appropriate commands and telemetry so that a user can note some change that is required, push a button to flip a relay or set a data source for instance, and then note the confirming telemetry after the command has been received in the satellite and the telemetry has returned to the ground station. In this manner the user can note possible effects of commands before actually sending them, since a block diagram is there to functionally indicate interactions which may not always be obvious. It is also an operating convenience to have a light change state shortly after sending a command to

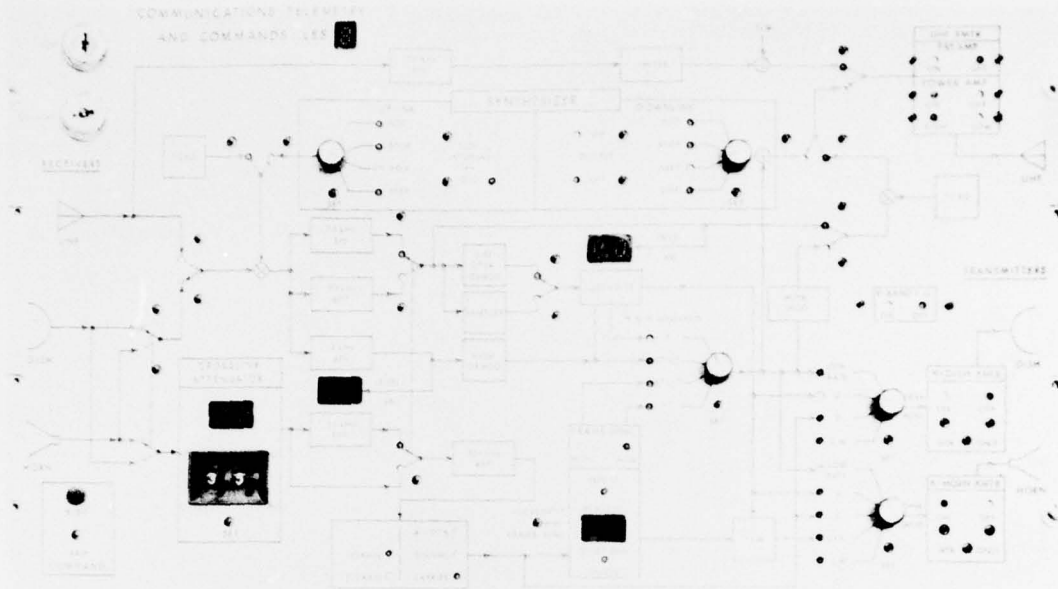

Figure 15. COMMUNICATIONS COMMAND/TELEMETRY PANEL

confirm its proper reception. The entire set of LES-8/9 Communications Command and Telemetry display panels is shown in Fig. (16). This arrangement is particularly well suited to the establishment and maintenance of a crosslink since crosslink pointing angles are converted from raw telemetry to decimal degrees, along with attitude control system roll and pitch information to allow quick interpretation. Associated commands are also interleaved with telemetry on the panels so that logical operation can occur. A close-up of the crosslink pointing panel is shown in Fig. (17). In using this panel to establish a crosslink, the user first initializes a mini-computer, primarily used by the communication modem, with attitude control references as displayed on a panel below the crosslink panel. The mini-computer now can send crosslink pointing command data bytes to the command system input storage in each rack. This transfer is initiated by the user and each command input accepts only pointing information for the satellite it is to command. This stored data is then converted as it would be if sent to the satellite and displayed in two windows labelled AZIMUTH and ELEVATION, Computed Pointing. A toggle switch can select either this data or manual data which in the case of computer failure, for instance, can be sent by pushing either the azimuth or elevation push button command load in the block diagram. The next set of windows to the left, COMMAND DESIGNATE MEMORY, is a telemetry display, suitably converted to decimal degrees, of the received angle command in the satellite just before it will be used to point the antenna in the acquisition mode. This display should match the

computed pointing display to verify correct data transfer. Pushing the EXECUTE button transfer this angle data to the dish which moves to the new angle. If the other dish is also pointed correctly the energy light will come on and autotrack can be engaged. The Dish Pointing and COMMAND DESIGNATE MEMORY angles are independent in autotrack and a user can note the reasons for this on the same panel.

While these panels do not set up a link or define an experimental mode by themselves, they do present the operator with a clear picture of the many modes of these satellites and offer a straightforward way to interact with the satellites. It should be noted that some additional flexibility has been incorporated in telemetry display by providing randomly selectable "probes" into the telemetry stream which can access any of the 400 telemetry words and display these 12-bit binary words in a number of formats, a "rule" taking the form of $MX + B$ where X is the raw telemetry value. Using this tool, we can monitor oscillator temperatures in degrees Centigrade, K-band power in milliwatts, or converter outputs in volts or amps, just to give examples of this useful feature.

As an aid in setting up a crosslink, for example, this system allows a crosslink to be established in less than 15 minutes, even for non-zero roll and pitch. Simple mode changes take a few seconds. Telemetry is always at hand to allow noting system configurations as quickly as possible. In the case of a hardware failure, a single rack can be used with either LES-8 or LES-9 by throwing a single switch.

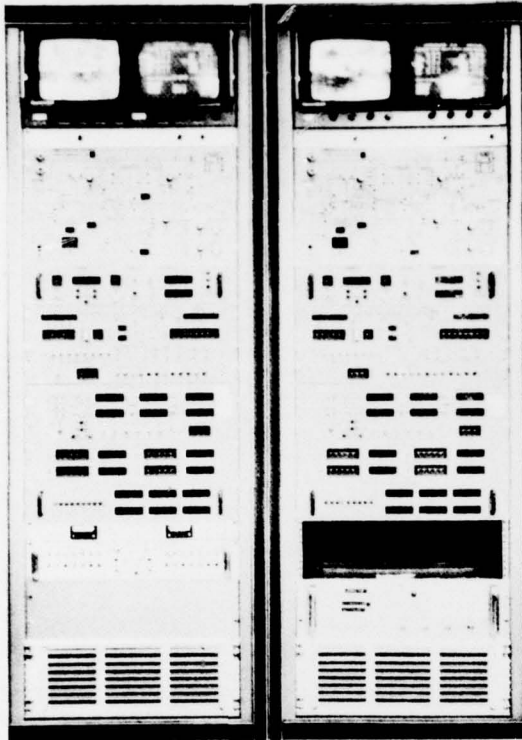

Figure 16.
LES-8/9 COMMUNICATIONS COMMAND/TELEMETRY SET

COMMAND AND TELEMETRY DISPLAY IMPLEMENTATION

Each display system contains a synchronizer that can accept a raw telemetry stream of 100 b/s or 10 kb/s and convert it to usable telemetry. This allows maximum flexibility in selection of source which may be a straight telemetry downlink

or stripped data from a downlink otherwise used for communications, either at UHF or K-band. The data synchronizer used requires only input telemetry data and a 1-MHz oscillator input. Displays note the occurrence of bit sync, frame sync and parity errors. After synchronization, 12-bit data bytes and 10-bit addresses are sent to the processing hardware for formatting and conversion to a usable display. Some conversion is simple logic while some is fairly complicated, such as angle conversion (0.44° per binary bit, two's complement), and uses a microprocessor chip.

The entire telemetry display subsystem uses about 500 integrated circuits. The command subsystem adds about 150 integrated circuits. Typical packages used in shown in Fig. (18).

The command subsystem was treated very carefully to avoid sending a command which could prove harmful to the satellite. A subset of the

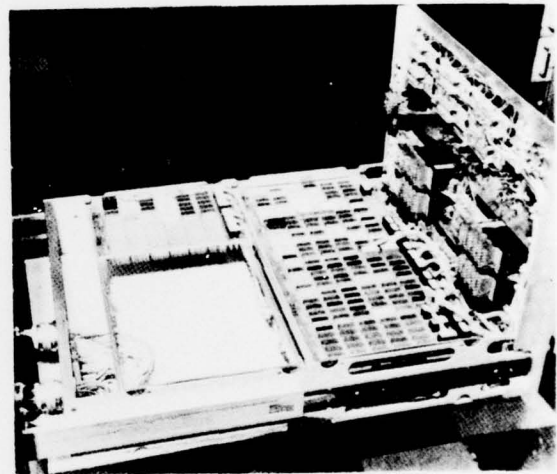

Figure 18. COMMAND/TELEMETRY PANEL CONSTRUCTION

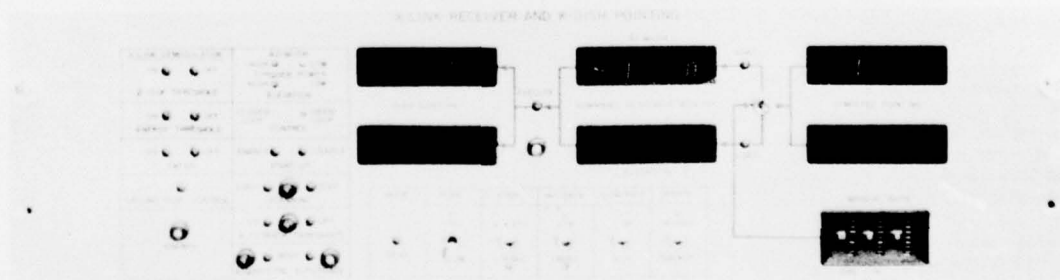

Figure 17. CROSSLINK POINTING PANEL

total command list was chosen according to the usefulness of a command in establishing a desired communications mode. In the satellite itself, a command can either enter data into a holding register, execute that associated data, change a relay, or produce a digital pulse at some input. Because of the 2^{63} possibilities for a data command, this command can only be practically formed with a logical circuit which inputs the desired data and outputs the 63 bits which make up a command. Other commands are stored in their entirety in ROMs and output as requested by the operator.

To reduce confusion which could cause a mistaken command to be sent, the selection of commands is decided by pushing a button located in a block diagram near the function to be commanded. No translation from function to name to number and the associated notebook listing is required. As mentioned before, a confirming telemetry display is located nearby to make doubly-sure that the satellite was properly commanded.

This implementation has also made possible a simplification that is more subtle. Some functions require more than the basic 12-bit data command to properly change. The command implementation used knows which push buttons require 1, 2 or more data transfers, formats the data from the panel appropriately, and sends as many commands as necessary. This ability to input data from the panel and translate it to satellite usable data is another time-saving feature available in this system. The system described is easily learned by new users of LES-8/9. It is a convenient way of describing various communications modes, by noting switch positions and data in red on copies of the panels. These copies then serve to "blueprint" the operation and allow quick reference to past operations. A keylock switch can disable the command functions of the system when used as a telemetry-only panel. Another keyswitch also serves to disable commands, such as setting the onboard real-time clock, which are sensitive to most communication experiments and are not sent without strict knowledge of how they are to be used.

Experience with these panels has shown that they have had the desired result of allowing the conductors of communications experiments to interact closely with the satellites without adversely affecting other systems in the satellites.

MEASURED SYSTEM PERFORMANCE

The crosslink pointing acquisition and tracking system performance is summarized in Figs. (19a, b, c). The pre-launch measurements were obtained by mounting LES-8 and LES-9 on two axis positioners separated by sixty feet. This separation was considered the minimum necessary to observe credible far field antenna performance.

The data shown in Fig. (19a) was obtained by pre-pointing the antenna boresight to generate worst case antenna alignments during SCAN. The

energy threshold was enabled to allow automatic switching from SCAN to TRACK if the energy detector in the autotrack receiver exceeded its threshold value. The resulting relationship shown in Fig. (19a) is therefore determined by the threshold setting of the energy detector in the receiver phase lock loop and not by the pointing equipment. The curve labelled CW indicates the improved pull-in performance that is available from a separate carrier detector in the autotrack receiver if the link degrades for any reason. It is evident from Fig. (19b) that the improvement in P_r/N_0 due to pull-in is adequate to ensure proper tracking.

Extensive use of the satellite-to-satellite data link since launch has demonstrated complete reliability in all cases. Both 10 Kb/s and 100 Kb/s links are normally operated in a region where bit errors due to random noise is less than a part in 10^4 . To compare present performance with that prior to launch, each dish was pointed to earth and a crosslink was established between a satellite and a ground station simulating another satellite. Data gathered in this way is compared to pre-launch data and shown in Figs. (20a, b) for LES-9. The crosslink has now been used to relay commands, telemetry, low-rate and high-rate communications simultaneously in both directions.

ACKNOWLEDGEMENTS

The design, integration, and testing of the systems described in this paper crossed many technical disciplines during the past five years. The authors wish to acknowledge the effort and cooperation of Dr. R. Bauer, Dr. D. Peterson, D. Hodsdon, and C. Much for integration and acceptance testing of the crosslink system; C. Sullivan for the inherently simple biax drive; D. Nathanson for the biax thermal control system; Dr. N. Smith for electro-mechanical design and analysis, and Dr. A. Dion for conceiving and delivering the lobing feed.

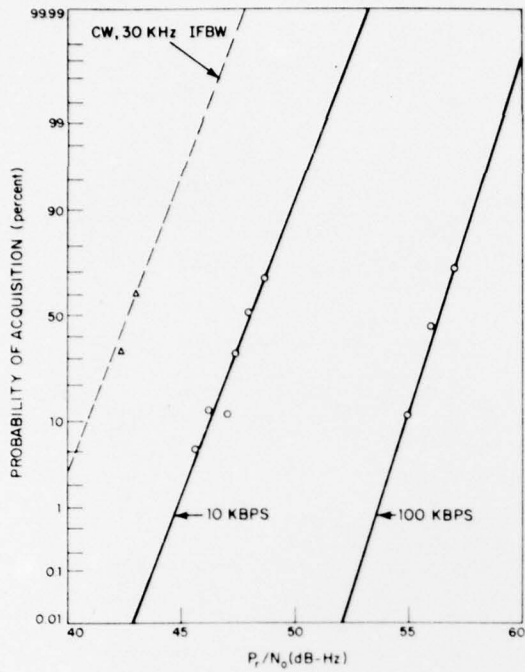

Figure 19a. PROBABILITY OF SPATIAL ACQUISITION

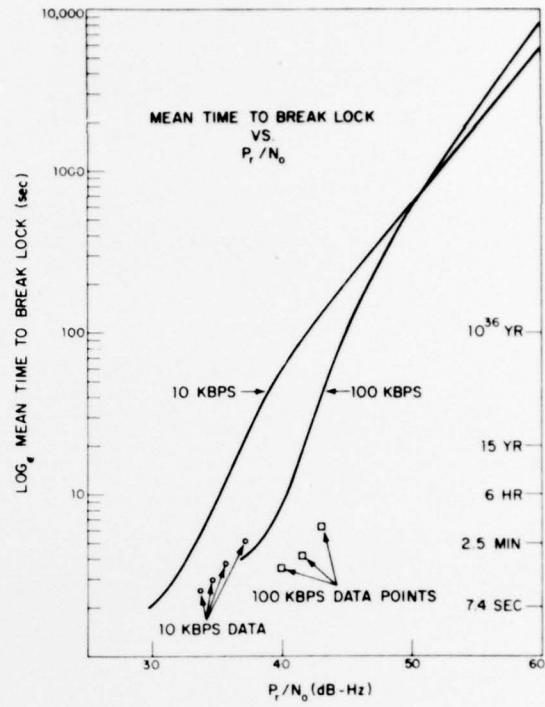

Figure 19b. MEAN TIME TO BREAK LOCK

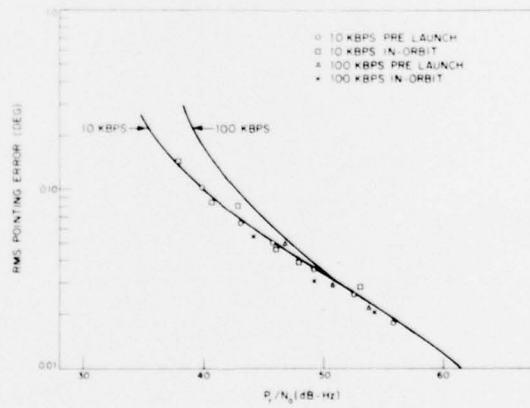

Figure 19c. TRACKING ACCURACY

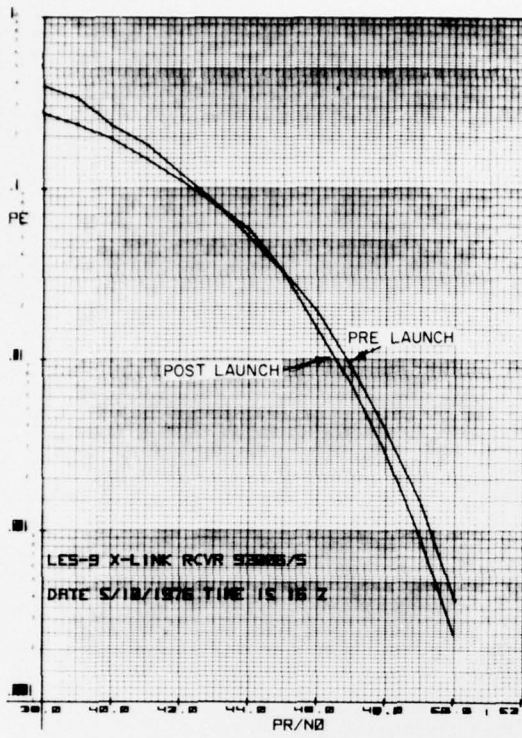

Figure 20a. CROSSLINK LOW RATE BER

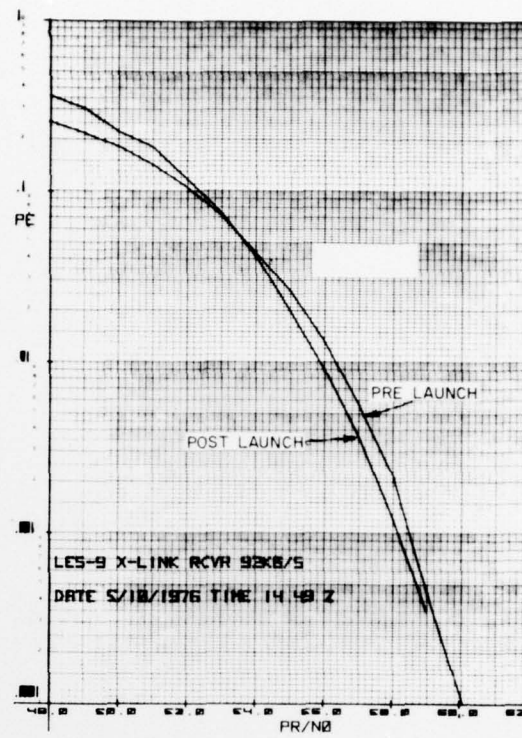

Figure 20b. CROSSLINK HIGH RATE BER

UNCLASSIFIED

SECURITY CLASSIFICATION OF THIS PAGE (When Data Entered)

REPORT DOCUMENTATION PAGE		READ INSTRUCTIONS BEFORE COMPLETING FORM
1. REPORT NUMBER ESD-TR-77-25	2. GOVT ACCESSION NO.	3. RECIPIENT'S CATALOG NUMBER
4. TITLE (and Subtitle) Satellite-to-Satellite Data Transfer and Control	5. TYPE OF REPORT & PERIOD COVERED Technical Note	6. PERFORMING ORG. REPORT NUMBER Technical Note 1977-4
7. AUTHOR(s) David M. Snider David B. Coomber	8. CONTRACT OR GRANT NUMBER(s) F19628-76-C-0002	9. PERFORMING ORGANIZATION NAME AND ADDRESS Lincoln Laboratory, M.I.T. P.O. Box 73 Lexington, MA 02173
10. CONTROLLING OFFICE NAME AND ADDRESS Air Force Systems Command, USAF Andrews AFB Washington, DC 20331	11. PROGRAM ELEMENT, PROJECT, TASK AREA & WORK UNIT NUMBERS Program Element No. 63431F Project No. 2029	12. REPORT DATE 19 January 1977
13. MONITORING AGENCY NAME & ADDRESS (if different from Controlling Office) Electronic Systems Division Hanscom AFB Bedford, MA 01731	14. SECURITY CLASS. (of this report) Unclassified	15. NUMBER OF PAGES 18
16. DISTRIBUTION STATEMENT (of this Report) Approved for public release; distribution unlimited.		15a. DECLASSIFICATION DOWNGRADING SCHEDULE
17. DISTRIBUTION STATEMENT (of the abstract entered in Block 20, if different from Report)		
18. SUPPLEMENTARY NOTES None		
19. KEY WORDS (Continue on reverse side if necessary and identify by block number) satellite communications global communications LES-9 pointing control LES-8 beam pointing		
20. ABSTRACT (Continue on reverse side if necessary and identify by block number) The LES-8 and -9 satellites are three-axis stabilized earth-orbit spacecraft which provide communications at UHF and K-band frequencies with the capability of simultaneously establishing and automatically maintaining a K-band (36-38 GHz) satellite-to-satellite data link. The inter-satellite data "crosslink" extends the earth coverage over that which a single satellite can provide and demonstrates how a global communications system might be realized without the restrictions imposed by ground relay. This report describes the operation and characteristics of the lobing antenna and pointing control, the solid state transmitters and receivers, the autotrack receiver and elastic shift register. Ground based and post-launch test results of pointing and communication systems are presented. Also, a user-oriented system is described which, among other features, allows an operator to easily establish a crosslink from the ground terminal using pointing angles calculated by a small computer from spacecraft derived earth pointing parameters.		

DD FORM 1 JAN 73 1473 EDITION OF 1 NOV 65 IS OBSOLETE

UNCLASSIFIED

SECURITY CLASSIFICATION OF THIS PAGE (When Data Entered)

207650

Handwritten signature or initials.