

AD-A041 324

RAYTHEON CO SUDBURY MASS EQUIPMENT DIV  
BOSTON AIR ROUTE TRAFFIC CONTROL CENTER (ARTCC)  
MAY 77 C M HALL, R M CARR, A J KOPALA

F/G 17/7  
LIGHTING STUDY (U)  
DOT-FA76WA-3738

UNCLASSIFIED

FAA-RD-76-203

NL

1 of 2

ADA041324

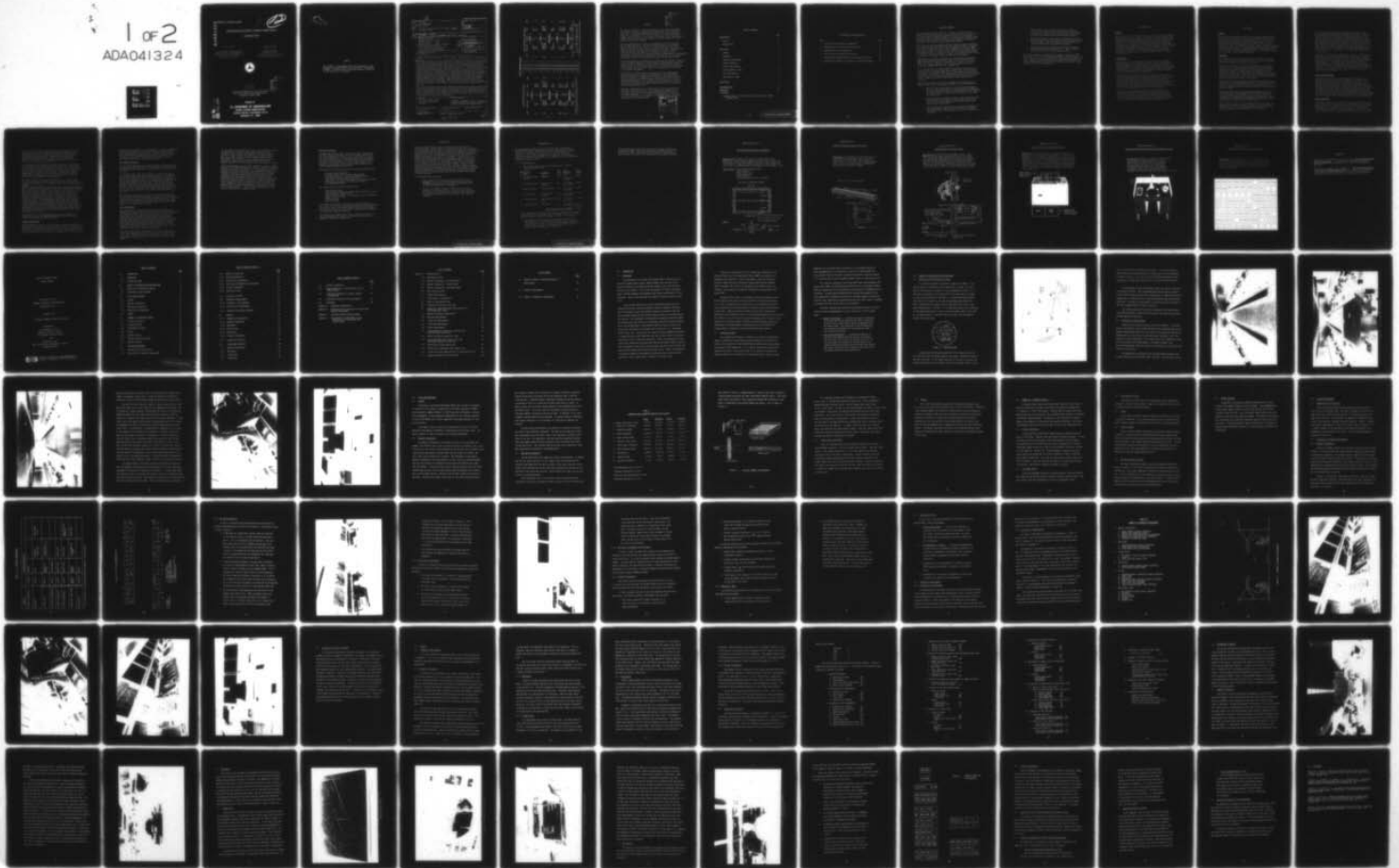

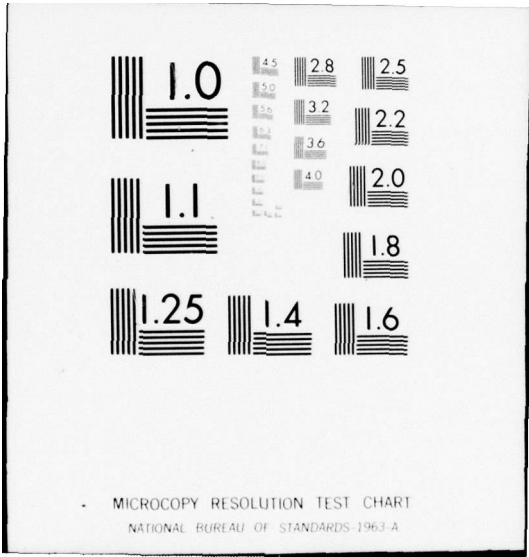

MICROCOPY RESOLUTION TEST CHART  
NATIONAL BUREAU OF STANDARDS-1963-A

AD A 041324

Report No. FAA-RD-76-203

*[Handwritten signature]* *[Handwritten circled number 12]*

BOSTON AIR ROUTE TRAFFIC CONTROL CENTER (ARTCC)

LIGHTING STUDY

Alan J. Kopala

Charles M. Hall  
Richard M. Carr

U.S. DEPARTMENT OF TRANSPORTATION  
FEDERAL AVIATION ADMINISTRATION  
Systems Research & Development Service  
Washington, D.C. 20590

RAYTHEON COMPANY  
EQUIPMENT DIVISION  
Air Traffic Control Directorate  
Sudbury, Massachusetts 01776



MAY 1977  
FINAL REPORT

Document is available to the U.S. public through  
the National Technical Information Service,  
Springfield, Virginia 22161.

DDC  
RECEIVED  
JUL 4 1977  
*[Handwritten initials]*

AD No. \_\_\_\_\_  
DDC FILE COPY

Prepared for

U.S. DEPARTMENT OF TRANSPORTATION  
FEDERAL AVIATION ADMINISTRATION  
Systems Research & Development Service  
Washington, D.C. 20590

87

NOTICE

This document is disseminated under the sponsorship of the Department of Transportation in the interest of information exchange. The United States Government assumes no liability for its contents or use thereof.

Technical Report Documentation Page

1. Report No. FAA-RD-76-203	2. Government Accession No.	3. Recipient's Catalog No.	
4. Title and Subtitle Boston Air Route Traffic Control Center (ARTCC) Lighting Study		Report Date May 1977	5. Performing Organization Code
7. Author(s) C. M. Hall, R. M. Carr (Raytheon); A. J. Kopala (FAA/SRDS)		8. Performing Organization Report No.	
9. Performing Organization Name and Address Raytheon Company Equipment Division ATC Directorate Sudbury, MA 01776		10. Work Unit No. (TRAVIS)	11. Contract or Grant No. DOT-FA76WA-3738
12. Sponsoring Agency Name and Address U. S. Department of Transportation Federal Aviation Administration Systems Research and Development Service (SRDS) Washington, DC 20591		13. Type of Report and Period Covered Final Report Apr. 1976 - Nov. 1976	
14. Sponsoring Agency Code DOT/FAA/ARD-100		15. Supplementary Notes With support from National Aviation Facilities Experimental Center (NAFEC) engineering and human factors personnel. Refer to Report No. FAA-RD-77-50.	
16. Abstract This report describes the work accomplished in reducing reflections on the faceplates of the Plan View Displays (PVDs) while increasing the level of ambient lighting, at Test Area D of the Boston ARTCC control room. This was intended, respectively, to improve the observation of PVD flight data by the air traffic controllers, and to facilitate reading and walking in the immediate aisle area. Raytheon lighting experts identified glare and reflection sources and lighting deficiencies, measured their various intensities with photometric test equipment, and provided practical suggestions to rectify the lighting problems. Their technical investigation, supplemented by extensive treatises on the optical definition and a literature review of the subject lighting reflection dilemma, was consolidated in a separate Raytheon Report and is attached to this FAA report. NAFEC engineered the lighting and equipment modifications advised by Raytheon. NAFEC human factors personnel surveyed the controller's opinions of the changes in the control room. Their work and findings are briefly described in this report. Details can be obtained in NAFEC Report No. FAA-RD-77-50.  The results of this project were the significant reduction of the PVD reflections and glare, and an increase in the ambient illumination, at the test location in Area D. It was concluded that: (1) the glare and reflections could be significantly reduced, but not eliminated, by minor equipment modifications; (2) the ambient light level could be increased to provide adequate visibility in the work aisle, but an exceptionally bright level could not be tolerated.			
17. Key Words Air Traffic Control (ATC) Plan View Display (PVD) Lighting		18. Distribution Statement Document is available to the U.S. public through the National Technical Information Service, Springfield, Virginia 22161.	
19. Security Classif. (of this report) Unclassified	20. Security Classif. (of this page) Unclassified	21. No. of Pages 162	22. Price

*Handwritten initials/signature*

## METRIC CONVERSION FACTORS

Approximate Conversions to Metric Measures			Approximate Conversions from Metric Measures			
Symbol	When You Know	Multiply by	To Find	Symbol	When You Know	
<b>LENGTH</b>						
in	inches	2.54	centimeters	mm	millimeters	
ft	feet	30	centimeters	cm	centimeters	
yd	yards	0.9	meters	m	meters	
mi	miles	1.6	kilometers	km	kilometers	
<b>AREA</b>						
in <sup>2</sup>	square inches	6.5	square centimeters	cm <sup>2</sup>	square centimeters	
ft <sup>2</sup>	square feet	0.09	square meters	m <sup>2</sup>	square meters	
yd <sup>2</sup>	square yards	0.8	square meters	m <sup>2</sup>	square meters	
mi <sup>2</sup>	square miles	2.6	square kilometers	km <sup>2</sup>	square kilometers	
	acres	0.4	hectares	ha	hectares (10,000 m <sup>2</sup> )	
<b>MASS (weight)</b>						
oz	ounces	28	grams	g	grams	
lb	pounds	0.45	kilograms	kg	kilograms	
	short tons (2000 lb)	0.9	tonnes	t	tonnes (1000 kg)	
<b>VOLUME</b>						
tsp	teaspoons	5	milliliters	ml	milliliters	
Tbsp	tablespoons	15	milliliters	ml	milliliters	
fl oz	fluid ounces	30	milliliters	ml	milliliters	
c	cups	0.24	liters	l	liters	
pt	pints	0.47	liters	l	liters	
qt	quarts	0.95	liters	l	liters	
gal	gallons	3.8	liters	l	liters	
ft <sup>3</sup>	cubic feet	0.03	cubic meters	m <sup>3</sup>	cubic meters	
yd <sup>3</sup>	cubic yards	0.76	cubic meters	m <sup>3</sup>	cubic meters	
<b>TEMPERATURE (exact)</b>						
°F	Fahrenheit temperature	5/9 (after subtracting 32)	Celsius temperature	°C	Celsius temperature	
°C	Celsius temperature	9/5 (then add 32)	Fahrenheit temperature	°F	Fahrenheit temperature	

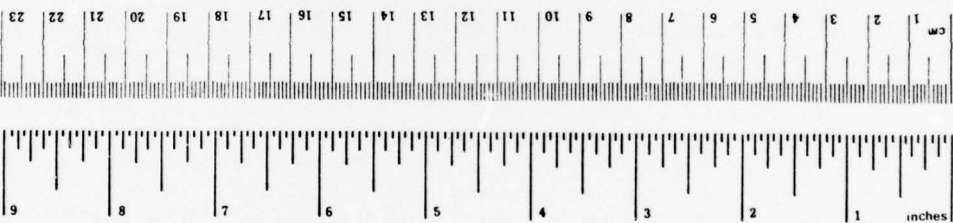

\*1 in. = 2.54 exactly. For other exact conversions and more detail tables, see NBS Misc. Publ. 286, Units of Weights and Measures, Price \$2.25, SD Catalog No. C13.10-286.

DDC  
RECEIVED  
JUL 7 1977  
RECEIVED

PREFACE

The physical properties of light and reflections are natural phenomena that cannot be changed. Therefore, any undesirable effects caused by light sources must be minimized by compromises and clever adaptation. Light that is incident to the front of a physical surface will always produce some reflections. This simple effect often creates objectionable problems particular to the observation of an object through the front surface of any optical medium.

Since the introduction of radar, the phenomenon of light reflections has disturbed operators. The need to monitor displays has confined them to dark control rooms devoid of the offending light that would otherwise obscure the scopes with reflections and glare. Many different solutions have been proposed and implemented in the past to reduce light reflections, but none have yet served as an absolute cure. The problems associated with increasing ambient lighting while simultaneously attenuating reflections are compounded by the complexity of the optical environment created by the numerous light paths in the control room.

Sincere appreciation is conveyed to Dr. Richard M. Carr and Mr. Charles M. Hall of Raytheon Company for their systematic and exhaustive work on the Lighting Study at the Boston Air Route Traffic Control Center (ARTCC) manifested by the text of this final report. Their unrelenting devotion to this effort has resulted in significant improvements to the control room lighting environment.

Much credit for having faithfully cooperated with the FAA/Raytheon Lighting Study team is given to the personnel of the Boston ARTCC. Special gratitude is extended to Mr. Theo Layton of Airways Facilities for his assistance in coordinating the sequence and location of the lighting modifications in the control room, and equally so, to Mr. Ed Walsh of Air Traffic for his representative function in facilitating the important information exchange between the air traffic controllers and the Lighting Study team.

For their outstanding work in fabricating the various modifications which have improved the control room lighting, the technicians and craftsmen of the National Aviation Facilities Experimental Center are highly commended. Also, a special acknowledgement is expressed to Mr. Morris Georgian, cartographer of the Boston Center, for having produced the black negative maps.

ACCESSION for	
DTIS	White Section <input checked="" type="checkbox"/>
DDC	Buff Section <input type="checkbox"/>
UNANNOUNCED	<input type="checkbox"/>
JUSTIFICATION.....	
BY.....	
DISTRIBUTION/AVAILABILITY CODES.....	
Dist. APPROVED BY SPECIAL.....	

TABLE OF CONTENTS

	Page
INTRODUCTION	
Purpose	1
Organization	1
DISCUSSION	2
General	2
Mapboards	2
Flight Strip Lighting	2
Ambient Lighting	3
Flight Strip Printer	4
Area Supervisor's Desk	5
Plan View Display	5
Human Factors Study	5
CONCLUSIONS	9
RECOMMENDATIONS	11
REFERENCES	19
ATTACHMENT	
Raytheon Report - Air Route Traffic Control Center (ARTCC) Lighting Study	

ILLUSTRATIONS OF MODIFICATIONS

Unit		Page
1	3M Light Control Material on Mapboards	13
2	Extended Louvers for Flight Strip Lighting	14
3	Dimmer Control for Plenum Lights	15
4	Green Filters for Flight Strip Printer	16
5	Lamp and Three-Sided Baffle for Area Supervisor's Desk	17
6	Photonegative Keycaps for Indicators on Plan View Display	18

## EXECUTIVE SUMMARY

The Boston ARTCC Lighting Study was a technical program intended to improve the lighting situation encountered by air traffic controllers in the control room. It had two purposes: to reduce the reflections that interfered in observing flight data on the Plan View Display (PVD) faceplates, and to increase the level of room lighting to adequately illuminate the center aisles for walking and reading.

In the study at the Boston ARTCC, Raytheon lighting experts determined the sources of glare and reflections, and suggested methods and material that would minimize this light. They documented this work for SRDS in a report entitled "Air Route Traffic Control Center Lighting Study." The Raytheon report is attached to this FAA final report and includes an extensive technical definition of glare and reflections, and a review of literature and former studies on these optical phenomena.

NAFEC directed the project engineering of the lighting and equipment modifications proposed by Raytheon. Human factors personnel from NAFEC surveyed the controllers' opinions on the changes. Details of their work, briefly summarized in this report, can be obtained by referring to NAFEC Final Report No. FAA-RD-77-50.

It is concluded from the Boston ARTCC Lighting Study that glare and reflections on the present PVDs can be significantly reduced, but not eliminated, by only minor modifications to the control room equipment and physical surroundings. Also concluded was that the level of control room lighting can be raised to permit better visibility in the center aisles. However, an exceptionally bright control room cannot be tolerated.

The following modifications to the equipment and lighting of the ARTCC control room are recommended by SRDS for field implementation:

1. Sheets of light control material should be placed between the sector maps and windows of the overhead console mapboards. This would establish a specific viewing angle for the controller of the map that would inhibit light transmitted to the PVDs across the aisle.
2. The present louver assembly attached to the flight strip lamp fixture should be replaced by one with longer, three-inch directive fins. This would more effectively shield light away from the adjacent PVD.
3. Special fluorescent dimmer controls should be installed for the plenum lights. These controls would permit a subdued room lighting level that would not be seen as reflections on the PVDs.

4. Form-fitting pieces of green filter plastic should be attached to the indicators and paper shield of the flight strip printer. These otherwise intense glare sources will be greatly attenuated by this type of filter material.
5. The area supervisor's desk should be equipped with a highly directional work lamp and a one-foot high light baffle along its three edges. This arrangement will prevent the desk light from illuminating adjacent PVD faceplates.
6. The present covers on the PVD keycaps should be replaced with ones made from photonegative film. These "negative" keycaps emit much less glare-producing light.

Due to the complexities imposed by the numerous light paths inside the control room, it is practically impossible to fully attenuate all light reflection sources by modifying the physical surroundings of the room. However, these modifications have significantly improved the ambient lighting situation and have attenuated many sources of light incident to the Plan View Displays.

## INTRODUCTION

### PURPOSE.

The objectives of the Boston Air Route Traffic Control Center (ARTCC) Lighting Study were to increase the level of ambient lighting in the ARTCC control room and to reduce the amount of glare and reflections on the Plan View Display (PVD) faceplates in order to provide the capability for air traffic controllers to observe unobscured PVD flight data in an adequately illuminated environment. These objectives originated from judgements by the en route controllers that the light reflections and glare were annoying and interfered with their monitoring of displayed flight data, and that the control room lighting was insufficient for reading memoranda and for walking in the center aisles.

### ORGANIZATION.

The Lighting Study was conducted in Area D of the Boston ARTCC control room and was a cooperative effort between the FAA and the Raytheon Company. Raytheon performed their work under Contract No. DOT-FA76WA-3738 for Systems Research & Development Service (SRDS) and documented it in a report for SRDS entitled "Air Route Traffic Control Center Lighting Study." The Raytheon report is attached to this FAA final report, No. FAA-RD-76-203.

The Raytheon report defined the optical phenomena associated with the lighting problems and described their work in the Lighting Study. Their activities consisted of measuring the intensities of the various light sources with photometric test apparatus, compiling and analyzing this lighting data, and, from this analysis, providing remedial modifications to the control room equipment and lighting. Also contained in the Raytheon report is a literature review and bibliography on the subject lighting problems.

Personnel from the National Aviation Facilities Experimental Center (NAFEC) engineered the lighting modifications advised by Raytheon and surveyed the controllers' opinions of the changes. Their work and findings are briefly described in the Discussion section. Details of the NAFEC engineering work and human factors study will be documented in Final Report No. FAA-RD-77-50.

## DISCUSSION

### GENERAL.

The significant improvements achieved in the Boston ARTCC Lighting Study were in the form of electrical and mechanical modifications to the control room equipment and facilities. The types that were experimentally modified were the overhead mapboards, the flight strip printer, flight strip lighting, the PVD consoles, the area supervisor's desk, and the ambient lighting. These modifications involved attenuating various sources of annoying reflections, while constrained with increasing the level of room illumination. The retrofits were basic in nature, and their installation did not considerably interfere with air traffic control (ATC) operations.

### MAPBOARDS.

Two methods were tried in order to eliminate the PVD reflections originating from the bright mapboards above the consoles: 3M Brand Light Control Material and black negative maps.

Light Control Material is made by the 3M Company, Visual Products Division. It is a sheet of plastic having an optical structure composed of many small "venetian blind" type louvers that direct light within a specific viewing angle. An illuminated object behind this material can only be seen when an observer is situated within this viewing angle. Outside of it, the entire sheet appears black and opaque. This is so, because the louvers block the light incident to an observer outside of the angle.

Light Control Material was placed between the front window of the mapboard and its illuminated IFR air chart. With this modification, the chart was visible to the controller below it, and yet, its image was inhibited from being formed on the PVD faceplate directly across the aisle.

The black negative maps are photonegative reproductions of the standard mapboard charts and are made from DuPont Crolux<sup>R</sup> film. On the black map, the alphanumerics and the vector lines are transparent and surrounded by an opaque black background. When illuminated, this "white on black" negative map inhibits much more light than the standard "black on white" type.

When installed in place of the standard IFR chart, the black map appeared as its negative and was discernible to the controller from any direction. Its strong point was its blocking of excess mapboard light from the PVD situated across the aisle.

The 3M Light Control Material was judged superior to the black maps in reducing mapboard light incident to the opposite PVD face. Although the black map reduced much extraneous light, it could still be noticed as a reflection on the opposite PVD face, which became progressively noticeable with the use of black maps showing increasingly more transparent information. The 3M material not only significantly reduced the mapboard reflection on the opposite PVD, but, by its louvered structure, directed light onto the aisle floor, aiding the ambient lighting. Also, the black maps were relatively expensive to produce and would need replacement whenever the need would arise to add, delete, or change any information on the black maps.

It should be noted that the 3M material, as well as the black maps, could present some resolution deficiencies when used to display finely detailed VFR aeronautical charts. These charts, although infrequently used by the controllers, are sometimes needed during certain instances of ATC work. A possible remedy for this incompatibility is to contain charts of this type into a common "window shade" that is mounted above the flight strip bay under the mapboard. To access the chart(s) the shade is pulled down over the top part of the flight strip bay, thus permitting close access to them by the controllers.

#### FLIGHT STRIP LIGHTING.

The flight strip lighting at the M1 console "D" positions were investigated during the Lighting Study because of light spillage from the flight strip lamp onto the PVD face. Several methods were studied, but the best solution to this particular problem was the attachment of a longer set of three-inch louvers to the flight strip lamp fixture. It was made similar to the original equipment louver attachment, with respect to mechanical fit, and was covered with a clear plastic sleeving for protection from the fin edges of the louvers. These deep louvers were extremely efficient in preventing light spillage onto the PVD face by directioning light only to the flight strips below and away from the adjacent PVD face.

#### AMBIENT LIGHTING.

The problem of insufficient ambient lighting involved coping with a dark environment in the control room in order to minimize annoying PVD reflections that would have been drastically increased by the introduction of a brighter level of lighting. To improve this situation, which hindered reading and walking in the center aisles, a new lighting control system was installed in Area D. It utilized

electronic dimmer controls specially suited for fluorescent lighting applications. This system provided continuous adjustments for balancing the two rows of plenum lights on top of the M1 consoles. The Raytheon lighting personnel experimented with this system and determined optimal control settings. This established a subdued level of ambient illumination without seriously affecting the Plan View Displays with reflections.

The new dimmer system increased the ambient lighting in the control room, indirectly, by having permitted low light level settings that were obviously better than having had no light at all, the latter being the only practical mode of operation for the old system. Logically, when the plenum lighting was raised above the prescribed amount it proportionally increased the reflections on the PVD faces and thus manifested a contradiction of the two main objectives of reducing reflections and increasing the room lighting.

It should be noted that other, more familiar types of light dimmers (e.g. autotransformers; "SCR" type units) were not tested because of their incompatibilities at low light levels for controlling fluorescent lighting.

Another approach intended to improve the control room ambient lighting was the experimental installation of Luxor Brand "Vita-Lite" fluorescent bulbs into the plenum fixtures of Test Area D. The bulbs have a soft light emission that resembles natural outdoor light with respect to the visual frequency spectrum. They were tested to evaluate their potential in providing more efficient illumination to allow the reading of memoranda and to ensure the avoidance of unseen obstacles in the aisle area. The introduction of Luxor lamps for the plenum lighting was only a slight improvement and did not invite further testing, although very little negative criticism of them was conveyed by the controllers. The Luxor lamps were also tried in the flight strip fixtures, but did not significantly improve the legibility of the printing on the flight strips, and did not contribute towards solving the contrast and light distribution problems relative to the PVD and the adjacent flight strips.

The application of 3M Light Control Material on the mapboards, as previously described (See MAPBOARDS section), contributed significantly in increasing the ambient lighting.

#### Flight Strip Printer.

Two disturbing glare sources were the brightly illuminated paper edge emerging from the flight strip printer and its "Ready" and "First Line" indicators. To attenuate the paper light source, various filter material were cut in the form of the original clear paper shield, substituted, tested, and evaluated. Using the same material, filter covers were made

and applied to the indicators. Filters made from a green transparent plastic proved superior in reducing the glare. These practical, low-cost modifications were very easy to install, since the new green paper shield was fabricated as a direct replacement for the original one, and the green plastic covers for the indicators were simply applied with a small drop of adhesive.

#### Area Supervisor's Desk.

The supervisor's desk was a main source of light that cause reflections on nearby PVD faceplates. To remedy this, a light baffle and a highly directional work lamp for the desk surface were installed and tested.

Five different desk lamps were evaluated, all having deep shades for directing light flow only to the desk surface. The lamps were used by the supervisors of Areas "A" through "D" of the control room at their respective desks. The ones preferred, judged by light directioning capability, were the Tensor Model 6500 and the Luxo "Student Crownlight" model desk lamps. The Raytheon lighting personnel analyzed both, and chose the Luxo lamp. It was chosen because it used a readily available incandescent bulb, rather than the 12 volt "auto" type bulb in the Tensor model, and because it had a longer, more versatile arm for better lamp positioning over the desk.

The twelve inch high baffle was composed of three wooden boards, painted black, and connected together widthwise, and was attached to the three edges of the desk surface opposite that of the supervisor. This modification inhibited light reflections from the desk glass surface. Both modifications prevented desk light from disturbing controllers at nearby sector consoles.

#### Plan View Display.

The many keycaps of the Plan View Display were disturbing glare sources to the controllers and were correctively modified by applying photonegative inserts. The new keycap inserts were made from a photographic film and appeared as the inverse of the original "positive" keycaps, having a black background with transparent lettering. The light emitted by the internal lamp passed through only the alpha-numeric legend and thus much excessive light glare was significantly reduced and the keycap appeared more legible. This modification was inexpensive, simple to install, and also included new nomenclature printed on the inserts for better representation of the function names they symbolized.

Not fully covered by the Raytheon Report were two modifications to the Plan View Display: the tilt device and the woven screening. These items, although initially very promising in concept, were unsuccessful, when implemented, in satisfying the Lighting Study goals.

The tilt device was a mechanical retrofit to the PVD that provided an adjustment of inclination angle, with reference to the horizontal, from 6 degrees to 68 degrees. Its purpose was to provide a viewing angle of the radar screen to the controller that would cause a minimum of front-surface reflections on it. When tested, the reflections were not significantly reduced, regardless of angle, and the modified PVD was difficult to maneuver whenever the need would arise, as, for instance, a repair.

The second modification involved the placing of a woven screening material on the PVD viewing surface. This was intended to disperse reflections from light incident to it. The material was a black polyester mesh cloth, named PeCap, and manufactured by Tetko, Inc. Although it decreased reflections without apparently degrading resolution, the woven screening had a very low value of light transmissivity (light passage characteristic) and therefore required the CRT intensity to be set at an excessively high level. This would seriously shorten the CRT life. Another disadvantage is the restrictive angle in viewing the ATC data caused by the optical geometry of the woven screening. Also, most controllers remarked that the modified display had an appearance of looking into "a long, dark hole." The woven screening modification was therefore rejected by the Lighting Study.

#### Human Factors Study.

The NAFEC Human Factors Study involved preparing, administering, and evaluating questionnaires, in order to measure the general levels of acceptance or rejection by the controllers of each of the lighting modifications. Each questionnaire contained mostly "yes or no" type questions and others required answers weighted according to a five-point scale. Also, written comments and suggestions pertaining to the individual modifications and the overall lighting problems were invited.

The majority of controllers accepted the following modifications:

- . 3M Light Control Mapboards
- . Extended Louvers for the Flight Strip Lighting
- . Fluorescent Dimmer for the Plenum Ambient Lighting
- . Green Filters for the Flight Strip Printer
- . Light Baffle and Directional Lamp for the Supervisor's Desk
- . Photonegative keycaps for the Plan View Display
- . Luxor Fluorescent Bulbs

Not accepted were the following modifications:

- . Black Negative Maps
- . Timer-Switch For Mapboard Lighting (For description, refer to Raytheon Report, section 5.2.2)
- . Under-the-Console Lamps (For description, refer to Raytheon Report, section 5.2.1)
- . PVD Tilt Device
- . Woven Screening

The results of the surveys indicated that the glare sources in the control room and the reflections on the PVDs had been attenuated by the total effort of the Boston ARTCC Lighting Study program. This improved the situation by an order of magnitude when compared to the previous lighting conditions.

For details of the Human Factors Study, including facsimiles of the questionnaires with tallies of the resultant data, refer to NAFEC Final Report No. FAA-RD-77-50.

## CONCLUSIONS

The Boston ARTCC Lighting Study has identified the glare and the reflection sources in Test Area D of the control room, and has produced various equipment modifications to attenuate these problems. Concurrently, the Lighting Study has allowed an increase in the ambient light level. However, both of these accomplishments have not, and could not have been optimized, because of the fact that a substantial increase in the ambient lighting to match that of, for example, a typical office room, would cause a commensurate and very undesirable amount of reflections of this light on the faces of nearby PVDs. This conflict of objectives clearly indicates the crux of the lighting dilemma: the mirror-like front surface of the PVD visual faceplate. Ideally, a display with no optically reflective viewing surface, such as would be found in an image projection system, would obviate this conflict. Unfortunately, both the physical requirements of computer-generated ATC data, and the present state-of-the-art in displays technology presently prevent this concept from materializing.

It is therefore concluded that:

1. Glare sources in the control room and reflections on the present PVD faces can be significantly reduced, but cannot be completely eliminated by performing minor modifications to facility lighting and ATC equipment.
2. The level of ambient lighting in the control room can be improved, to a moderate extent, that now permits visibility of the work aisle in Test Area D. However, under the present conditions, an exceptionally bright control room cannot be tolerated.

## RECOMMENDATIONS

The recommendations proposed herein constitute the official reply from Systems Research and Development Service (SRDS), ARD-100, to Air Traffic Service (ATS), AAT-100, based on the R,D&E Request No. 9550-AAT-100-34. Those ideas and suggestions directly or indirectly expressed by the Raytheon Company in this report do not necessarily represent the official recommendations of SRDS, and are to be regarded for informational purposes only.

It is recommended that:

1. The following ARTCC control room modifications should be implemented in the field:

<u>MODIFICATION UNIT</u>	<u>EQUIPMENT</u>	<u>UNIT COST</u>	<u>ARTCC QUANTITY*</u>	<u>ARTCC COST*</u>
1. 3M Light Control Material	Mapboards	\$50	105 (3 units per sector)	\$5250
2. Extended Louvers	Flight Strip Lighting	\$30	35 (1 unit per sector)	\$1050
3. Dimmer Control	Plenum Lighting	\$70	8 (2 units per area)	\$ 560
4. Green Filters	Flight Strip Printer	\$25	35 (1 unit per sector)	\$ 875
5. Lamp and Baffle	Area Supervisor's Desk	\$40	4 (1 unit per area)	\$ 160
6. Negative Keycaps	PVD Console	\$5	35 (1 unit per PVD console)	\$ 175
<u>Total Estimated Cost Per ARTCC:</u>				<u>\$8070</u>

\* Cost and quantity of modification units was based on a projected mean value of 35 sector consoles per each ARTCC. (Source: AAT-100, Projected Number of Domestic Sectors, 11/2/76: 1977 estimate)

2. Major emphasis and a high priority should be placed on the development of a new cathode-ray tube with an anti-reflective viewing surface. Work is presently being conducted by SRDS and NAFEC towards this goal in conjunctive fulfillment of the subject R,D&E 9550 Request No. AAT-100-34.

The following pages describe and illustrate the above modifications recommended by SRDS to ATS that would improve the ARTCC control room lighting situation. They provide general guidelines regarding the specification, fabrication, and installation of the subject retrofits.

MODIFICATION UNIT #1

3M LIGHT CONTROL MATERIAL ON MAPBOARDS

Description: Two 10-3/8" x 33" pieces of the 3M Light Control Material are taped together, along their longer sides, to form one complete unit to fit in the mapboard. The unit is then taped, along its perimeter, to the rear of the clear plastic cover located over the air map. Availability Source: 3M Company, St. Paul, Minn. 55101.

Specifications: Louver Material-Opaque Black  
Surface-Glossy  
Filter Color-Clear  
Aspect Ratio-3.5:1  
Louver Angle-18°  
All other specifications are standard.

Rear View of Mapboard Assembly

Top Side

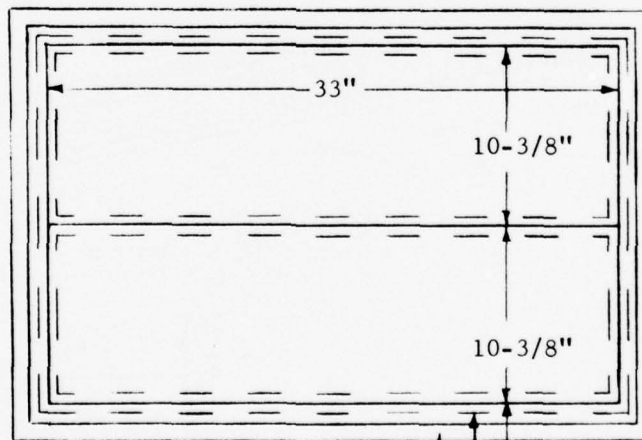

Bottom Side

- Light Control Material
- 1" Wide Clear Tape
- Mapboard Frame

Theory:

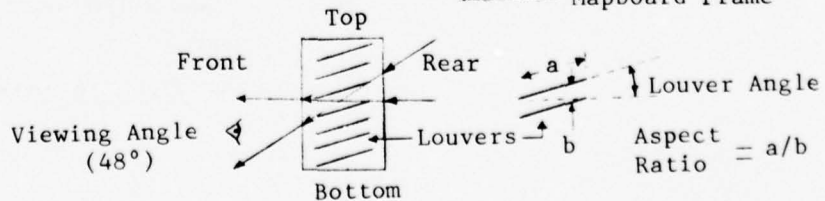

MODIFICATION #2

EXTENDED LOUVERS FOR FLIGHT STRIP LIGHT

Description: This assembly of deep metal louvers is a direct physical replacement for the present standard set of louvers that direct light to the flight strips. It is fitted, on the light-emitting side, with a clear plastic shield. Availability Source: Local fabrication at NAFEC.

Frontal View of Louver Assembly

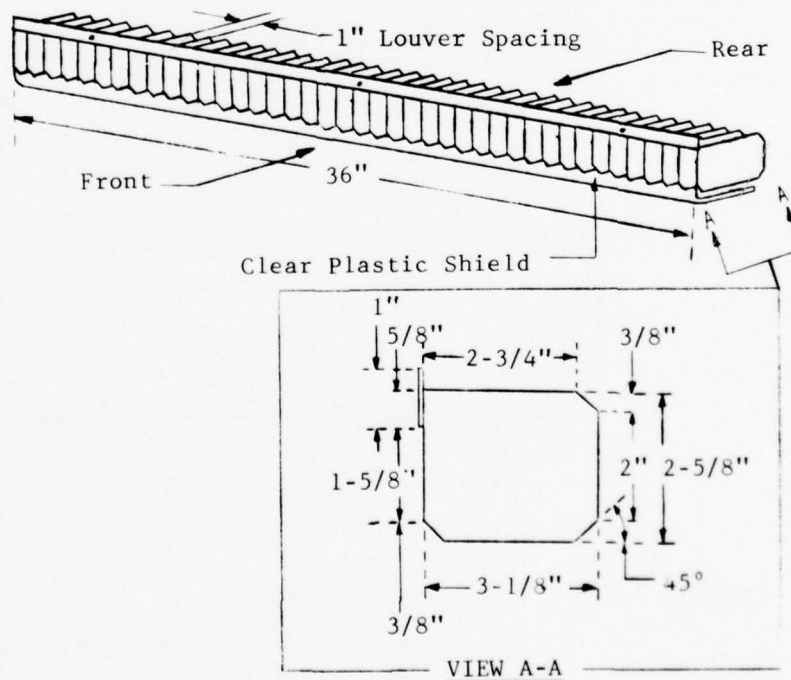

MODIFICATION UNIT #3

DIMMER CONTROL FOR PLENUM LIGHTS

Description: The fluorescent lamp dimmer, Luxtrol type, model no. LFD-10A, made by Superior Electric Co., installs in a standard 2½" deep single switch box and can be used with any standard switchplate. An internal switch opens the input to the system when the knob is turned to the "Off" position. A low intensity adjustment is located on the front of the unit and is covered by the switchplate when installed. Source: The Superior Electric Co., Bristol, Connecticut 06010.

Dimmer Control

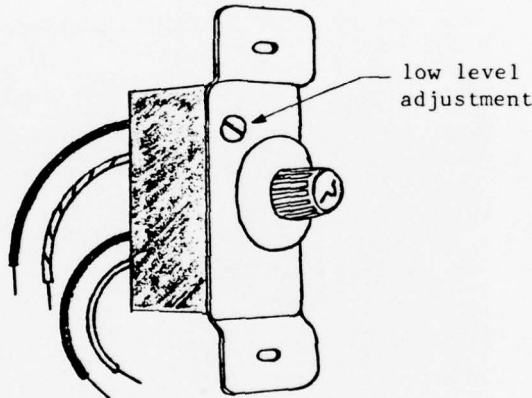

Suggested Installation Diagram

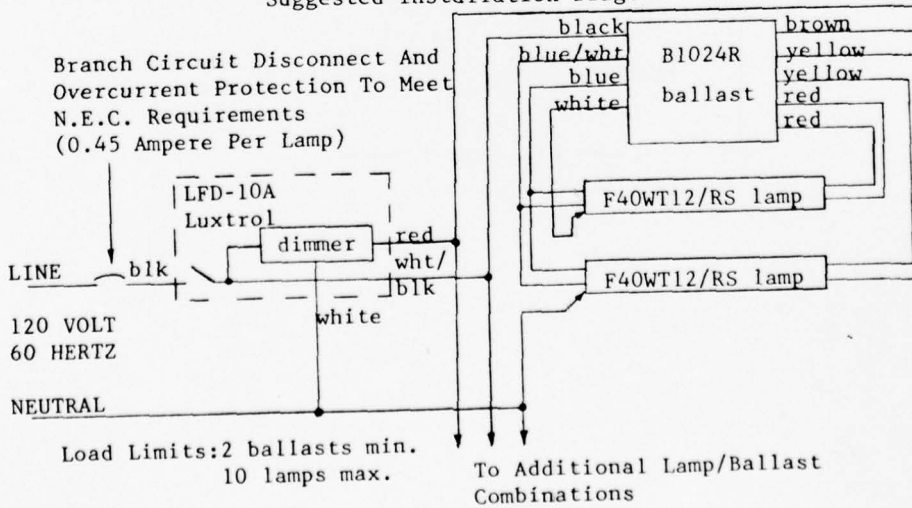

MODIFICATION UNIT #4

GREEN FILTERS FOR FLIGHT STRIP PRINTER

Description: The filter cover for the paper illuminator is fabricated from clear green filter plastic. It is cut to the dimensions of the original clear paper cover to fit into its retaining slots on top of the printer. The same type of green filter plastic is cut to fit each surface of the "Ready" and "First Line" indicators. A small drop of glue applied to each corner of the inner surface of the indicator filters ensures sufficient adhesion to the indicator surfaces. Availability Source: Rohm-Haas Co., Philadelphia, PA; Green Plexiglass, Shade Number 2092.

Green Clear  
Plastic Filter  
Paper Cover

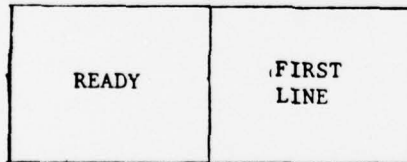
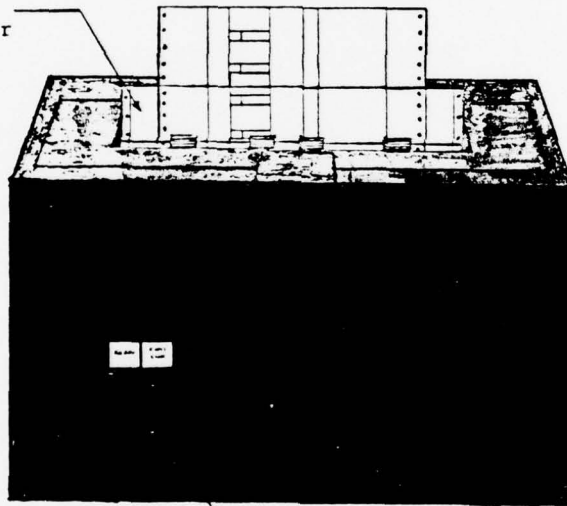

Green Clear  
Plastic Covers  
For Indicators

## MODIFICATION UNIT #5

LAMP AND THREE-SIDED Baffle FOR AISLE SUPERVISOR'S DESK

Description: The baffle is composed of three pieces of one-foot wide, quarter-inch thick plywood, painted black, and mounted along the adjacent three sides of the desk surface. The lamp is the Luxo Crownlight student desk lamp and has an elongated shade with a recessed incandescent light bulb. Availability Source: Baffle made at NAFEC. Lamp from Luxo Lamp Corp, Port Chester, NY 10573



MODIFICATION UNIT #6  
PHOTONEGATIVE KEYCAPS FOR PVD INDICATORS

Description: The new keycap inserts for the PVD indicators are made from a photo negative film cut to the same size as the original keycap inserts. The photo-negative inserts also contain new and improved legends, and are installed in the same way as the original inserts. Availability Source: Local fabrication at NAFEC.

TRNG	OTMP	PSET	MANL	CPOW	CDCP		CFAL	SROB	SROB
SROB	SROB	RDR 1	RDR 2	RDR 3	RDR 4	DSIM	RSB		
						NONE	AHAN	CANC	REDO
REPT	CO	HOLD	CRD	QIKL		TRAC	RUTE	PVD	I ALT
CODE	AID	AALT	RALT	CID	ESBC		LEAD	PSYM	WXI
WX2	STRB	MAP 1	MAP 2	MAP 3	MAP 4	INLT	DPLT	HOLT	
FUDB	ALDB	SLDB		APRM	NMCB	SBCN		00 52	53 72
73 102	103 142	143 175	176 255	256 340	341 999				

#### REFERENCES

1. Gustafson, P. C.; Aschenbach, J.; Sulzer, R. L. Plan View Display (PVD) Background Lighting, U. S. Department of Transportation, Federal Aviation Administration, Washington, D.C. Report No. FAA-RD-76-46, May 1976.
2. Mitchell, R. H.; Sulzer, R. L.; Kopala, A. J. Boston Air Route Traffic Control Center (ARTCC) Lighting Study, U. S. Department of Transportation, Federal Aviation Administration, National Aviation Facilities Experimental Center; Atlantic City, N.J. Report No. FAA-RD-77-50.

ARTCC LIGHTING STUDY

FINAL REPORT

Prepared for the  
FEDERAL AVIATION ADMINISTRATION  
WASHINGTON, D. C.

AUGUST 1976

CONTRACT NUMBER FA76WA-3738, MOD 1

Prepared by

Dr. Richard M. Carr  
Submarine Signal Division  
Portsmouth, Rhode Island

and

Charles M. Hall  
ATC Directorate, Equipment Division  
Wayland, Mass.



RAYTHEON COMPANY  
EQUIPMENT DIVISION

TABLE OF CONTENTS

	<u>PAGE</u>	
1.0	INTRODUCTION	1
1.1	Background	1
1.2	Purpose and Scope	2
2.0	SOURCE OF SPECULAR REFLECTION AND GLARE	4
2.1	Definition of Reflection Problem	4
2.2	Definition of Glare Problem	6
3.0	FIELD INVESTIGATIONS	13
3.1	Purpose	13
3.2	Ambient Illumination	13
3.3	Map Board Illumination	14
3.4	Flight Strip Illumination	17
3.5	Summary	18
4.0	SUMMARY OF LITERATURE RESEARCH	19
4.1	Circular Polarizers	19
4.2	Wire Mesh Filters	19
4.3	Color/Neutral Filters	20
4.4	Etches	20
4.5	Optical Coating	20
4.6	Etching and Optical Coating	20
4.7	Ambient Lighting	21
5.0	EVALUATION PROCEDURE	22
5.1	Description of Test Facility	22
5.2	Description of Potential Improvements	22

TABLE OF CONTENTS (CONT'D.)

	<u>PAGE</u>
5.2.1 Ambient Illumination	22
5.2.2 Map Board Reflection	25
5.2.3 Flight Strip Illumination	27
5.2.4 PVD Console Pushbuttons and Indicators	29
5.2.5 Printer Illumination	29
5.2.6 Supervisor's Desk	30
5.3 Evaluation Criteria	32
5.4 Photometric Measurements	32
5.4.1 Photometric Test Equipment	32
5.4.2 Description of Measurements	33
5.5 Subjective Evaluation Procedure	40
6.0 RESULTS	41
6.1 Photometric Measurements	41
6.1.1 Ambient Illumination	41
6.1.2 Map Boards	42
6.1.3 Flight Strips	42
6.1.4 PVD Console	43
6.1.5 Printer Illumination	44
6.2 Subjective Evaluation	44
7.0 DISCUSSION OF RESULTS	49
7.1 Ambient Illumination	49
7.2 Map Boards	53
7.3 Flight Strip	53
7.4 PVD Console	57

TABLE OF CONTENTS (CONT'D)

	<u>PAGE</u>
7.5 Printer Illumination	61
7.6 General Reactions of the Controllers to the Modifications	61
7.7 Controller Suggestions for Other Lighting Improvements	61
7.8 Controller Evaluation of Testing Methods	63
8.0 REFERENCES	64
Appendix A Photometric Measurements	
Appendix B Questionnaire for Evaluation of Control Room Lighting Improvements	
Appendix C Literature Review and Bibliography	
Appendix D Illustrations of Improvements by the Modifications of the Boston ARTCC Lighting Study	

## LIST OF FIGURES

	<u>PAGE</u>
Figure 2.1 PVD Reflections	4
2.2 Reflections on PVD	5
2.3 Ambient Illumination - Cleveland ARTCC	7
2.4 Ambient Illumination - Atlanta ARTCC	8
2.5 Ambient Illumination - Washington ARTCC	9
2.6 Glare Sources on PVD	11
2.7 Printer Glare Sources	12
3.1 Light Control Film Operation	16
5.1 Setup of Experimental Area	24
5.2 "Black Map" Installed In Test Area	26
5.3 Comparison of Map Board With Light Control Film and Standard Map Board	28
5.4 Ambient Illumination Measurements	35
5.5 Map Board Measurements	36
5.6 Flight Strip Measurements	37
5.7 PVD Console Measurements	38
5.8 Printer Measurements	39
7.1 Balanced Ambient Illumination with Map Board Light Directed Toward Aisle	50
7.2 Baffle and Lamp on Supervisor's Desk	52
7.3 View of Map Board with Light Control Film From Radar Controller's Position	54
7.4 Reflection of "Black" Map on PVD	55
7.5 Flight Strip Illumination With Louvers Only	56
7.6 Flight Strip With Louvers and 24" of Light Control Film	58
7.7 Suggested Legends for PVD Indicators	60

LIST OF TABLES

	<u>PAGE</u>
3.1 Comparative Mean Illumination Readings at ARTCC Centers	15
5.1 Potential Improvements	23
5.2 Summary of Photometric Measurements	34

## 1.0 INTRODUCTION

### 1.1 Background

The introduction of the Plan View Display (PVD) in the vertical position at Air Route Traffic Control Centers (ARTCCs) has resulted in the specular reflections from opposing display surfaces, walls and ceiling on the face of the display. Prior to the introduction of digital narrowband radar, the PVD presented only broadband radar and was positioned at 6° from horizontal. When in this position, the specular reflection problem did not exist.

Since the PVDs have been set at 68° from the horizontal position, complaints have been raised by controllers about the specular reflections. The first attempt to solve the problem consisted of turning off both the direct overhead lights, and the indirect lights located in the plenums behind the consoles. This succeeded in eliminating the specular reflections emanating from the walls and ceiling, but caused four other, more serious problems. First, the extinguishing of the overhead lighting failed to eliminate the specular reflections on the other side of the aisle, e.g., map boards, flight strips, etc. Second, since the control room was darkened considerably, it became difficult to walk down the aisle and to read or write at any position but the "A or D" controller positions. Third, the difference in illumination level between the relatively dark PVD and the bright flight strips has led to complaints of eye strain since the radar controllers must visually scan back and forth between the PVD and the flight strips. Fourth, the decreased illumination revealed a new problem of distracting glare sources from the supervisor's desk, speaker bezels, printers, and flight strips.

Preliminary investigations of this problem were undertaken at the National Aviation Facility Experimental Center (NAFEC) and potential improvements were identified. These investigations could not be carried further at NAFEC because of differences between NAFEC and the standard ARTCC environment due to lower ceiling height, non-carpeted floors, etc. Therefore, the evaluation of potential improvements was conducted at the Boston ARTCC.

The goal of this study is to recommend a working environment similar to that which existed prior to placing the PVDs in the vertical position, i.e., a well illuminated control room similar to the standard office working environment while eliminating glare on working surfaces and reflections on PVD faces. Combining implosion shields and anti-glare coatings with etching for large cathode ray tubes is also being considered but since this possible solution is only in the early stages of development, this study will concentrate on eliminating specular reflection and glare wherever possible by determining the maximum ambient illumination which can be allowed with minimum specular reflection from the existing PVD screen surface.

## 1.2 Purpose and Scope

This program was initiated in response to an R/D Test and Evaluation request by AAT-100 to Systems Research and Development Service (SRDS) as a result of the submittal of Form 9550-AAT-100-34, ARTCC Control Room Lighting. The purpose of this program was: 1) to identify and measure the sources of specular reflections in the control room; 2) to review the literature for possible solutions to the problem; 3) to provide near-term, low-cost recom-

mendations for eliminating these reflections; 4) to evaluate efficacy of these recommendations in an operational setting at the Boston ARTCC and, 5) to provide long-term solutions to obviate the specular reflection problem in its entirety and to raise the general ambient light to a comfortable level.

This study was performed at the Boston ARTCC under SRDS management with support from NAFEC, the FAA New England Regional Office and Raytheon Company. NAFEC was responsible for the engineering of modifications, implementation and evaluation. The New England Regional Office provided the manpower for program coordination and hardware installation. Raytheon Company performed the lighting study, identified and measured reflection and glare sources, recommended possible solutions and assisted in the evaluation.

The ARTCC Lighting Study identified objectionable specular reflection sources and made recommendations for their elimination in the following areas:

1. Ambient Illumination - Including the specular reflections of the walls and ceiling caused by the direct illumination from the ceiling lights and/or indirect illumination from the plenum lights. The reflections on the PVD emanating from the direct illumination of the supervisor's desk is also covered in this area.
2. PVD Surround Reflections - Including the specular reflection on the opposing PVD, the glare on the adjacent PVD from flight strips on the M-1 console, the glare from the pushbuttons and indicators on the PVD console, the specular reflection and glare from the flight strip printer and printer indicators, and the specular reflection of the map board associated with the opposing PVD.

## 2.0 SOURCES OF SPECULAR REFLECTION AND GLARE

### 2.1 Definition of the Reflection Problem

The reflection problem on the PVD is common to all ARTCCs. Four distinct bands of reflection, shown schematically in Figure 2.1, and as seen by the controller in Figure 2.2, are encountered on the PVD: 1) A dark band corresponding to the reflection of the underside of the canopy is seen at the top quarter of the PVD. 2) A second light band caused by the reflection of the wall or the ceiling (depending upon whether the PVD is located along the center aisle or along the wall) is seen in the upper middle quarter of the PVD. 3) A bright band caused by the reflection of the opposing map boards is seen in the lower middle quarter of the PVD. 4) The lower quarter of the PVD reflects the lights from the opposing console and flight strips.

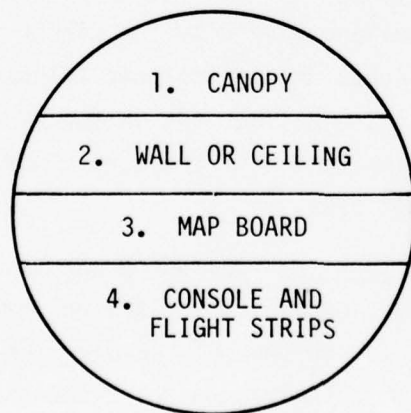

FIGURE 2.1 - PVD REFLECTIONS

The dark band reflecting the underside of the canopy does not distract the controller, but rather enhances the target to background image on the face of the CRT. In the second reflection of the wall or ceiling, the specular reflection from the overhead lights and the plenum lights is one of

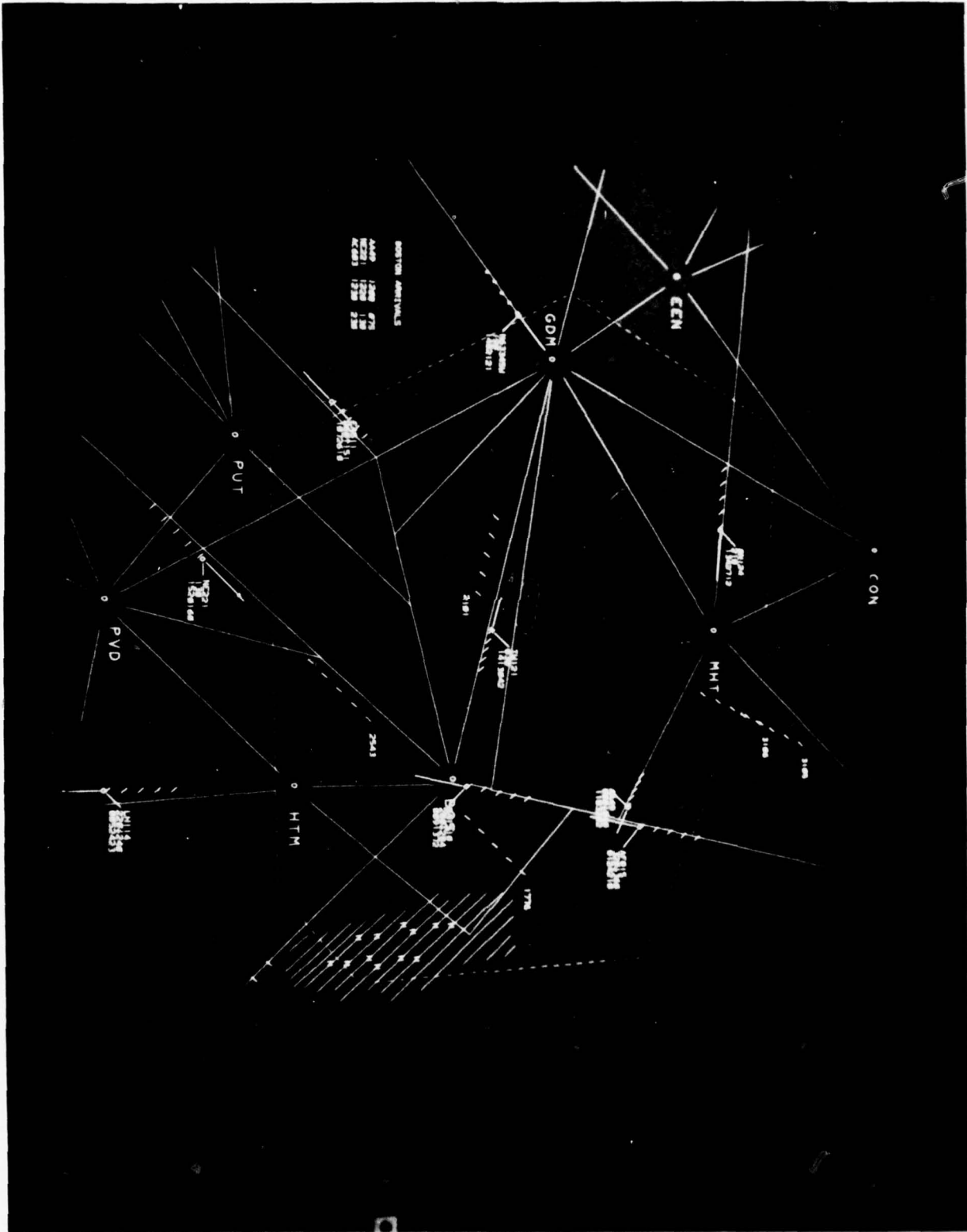

FIGURE 2.2 - REFLECTIONS ON PVD

the principal sources of reflection on the PVD. The overall problem is complicated by the non-uniform ambient illumination at the various ARTCCs as shown in Figure 2.3, 2.4, and 2.5 and by individual differences among controllers as to what they consider to be a serious reflection problem.

The map boards are the single greatest source of specular reflection in the face of the PVD. They are mounted above the PVDs and M-1 Consoles at 30° from the vertical and are rear illuminated by a standard 40 watt fluorescent lamp. A diffusing filter is placed between the lamp and the translucent map. The angle of the map boards is such that they are reflected in the face of opposing PVDs as shown in Figure 2.2.

The console lamps and flight strips reflected in the lower portion of the PVD are normally blocked out by the body of the controller and cause minimum controller distraction.

## 2.2 Definition of Glare Problem

There are four principal sources of glare in the ARTCC: 1) the push-buttons and indicators that surround the PVD and the illuminated keys of the keyboard mounted below the PVD; 2) the flight strip fluorescent lamp and the speaker bezel; 3) the printer face and the printer indicators; and 4) the supervisor's desk illumination. In all these cases, the illuminating sources are too bright and the extreme change in illumination between them and the PVD apparently causes eye fatigue as the R-controller looks from these sources to the PVD face.

The pushbuttons and indicators that surround the PVD presently have a single rheostat controlling both sides of the PVD. Since the sides are not



FIGURE 2.3 - AMBIENT ILLUMINATION - CLEVELAND ARTCC

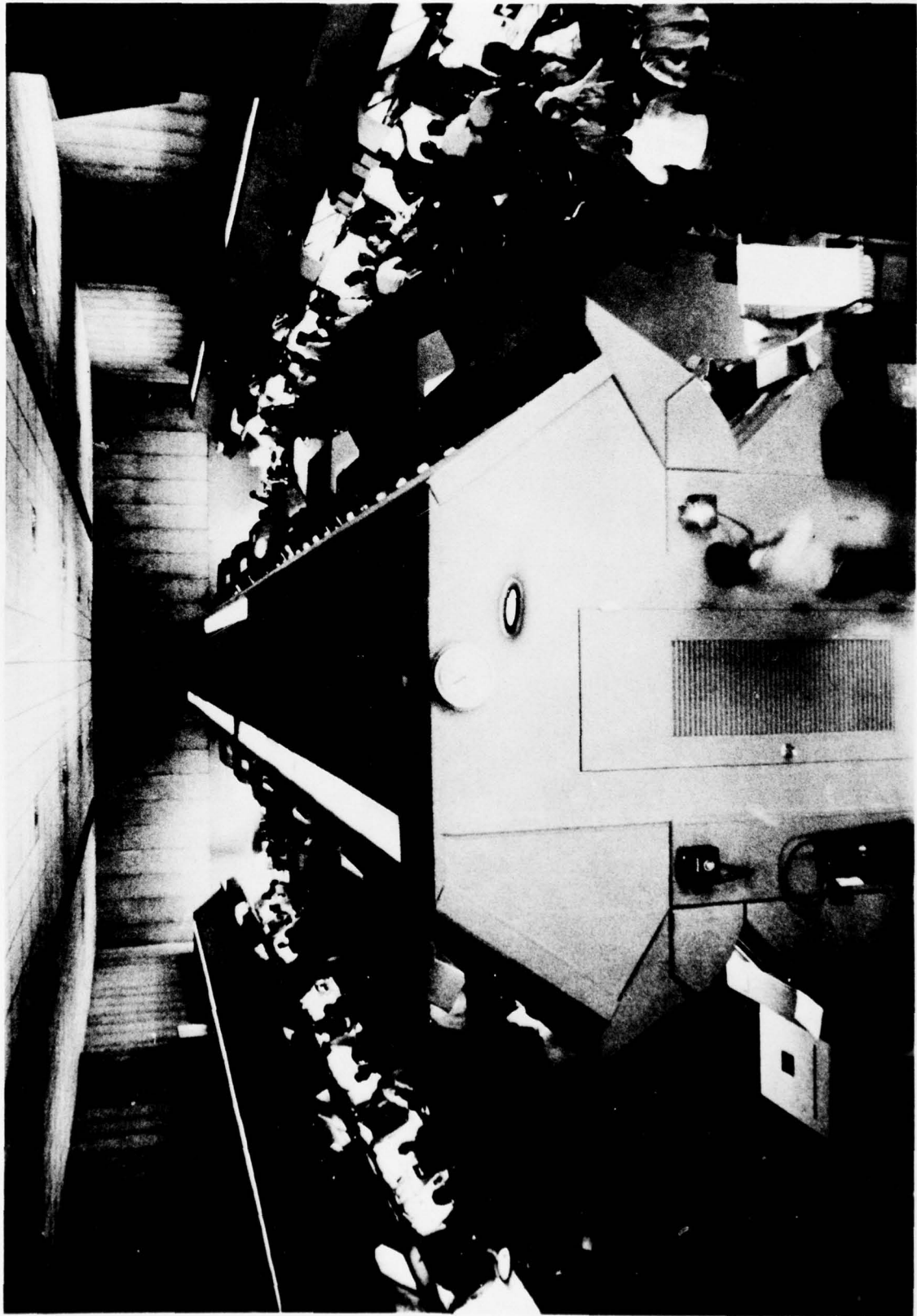

FIGURE 2.4 - AMBIENT ILLUMINATION - ATLANTA ARTCC



FIGURE 2.5 - AMBIENT ILLUMINATION - WASHINGTON, D. C. ARTCC

equally balanced, when the darker side is bright enough to be legible, the lighter side becomes a glare source. Figure 2.6 shows this difference in brightness as well as the difference between the PVD face and flight strips.

The most difficult problem to resolve is that of satisfactorily illuminating the flight strips so the light level is compatible with the PVD. The 1/2" mechanical louvers presently located under the flight strip lamp do not adequately deflect the stray light from the face of the PVD (as shown in Figure 2.6); therefore, the radar controller has two major complaints: 1) the strong light on the edge of the PVD face is distracting, and 2) he is forced to accommodate his eyes as he scans back and forth between the PVD and the flight strips. The difference in contrast leads to complaints of eye strain. If the intensity of the flight strip illumination is lowered to the point where the stray light on the PVD is eliminated, it is almost impossible to read the flight strips. Additional complicating factors are that the most important region of the flight strip area is that which is closest to the PVD, and that the fluorescent lamp has a 2:1 ratio in illumination intensity from the center to the edge, which causes the area closest to the PVD to have the least amount of illumination. Also, the polished aluminum bezel of the speaker acts as a reflected glare source. The high intensity illumination of the printer and printer indicators shown in Figure 2.7 are also glare sources.

The general ambient illumination has been reduced but the supervisor must have adequate illumination for the performance of his tasks; therefore, supplemental illumination is required at his position. In those ARTCCs where the supervisor's desk is located in the center of the aisle, fluorescent lamps have been located on the desk. These lamps emit either direct or reflected stray light off of the surface of the desk. This is distracting to the controllers.



FIGURE 2.6 - GLARE SOURCES ON PVD

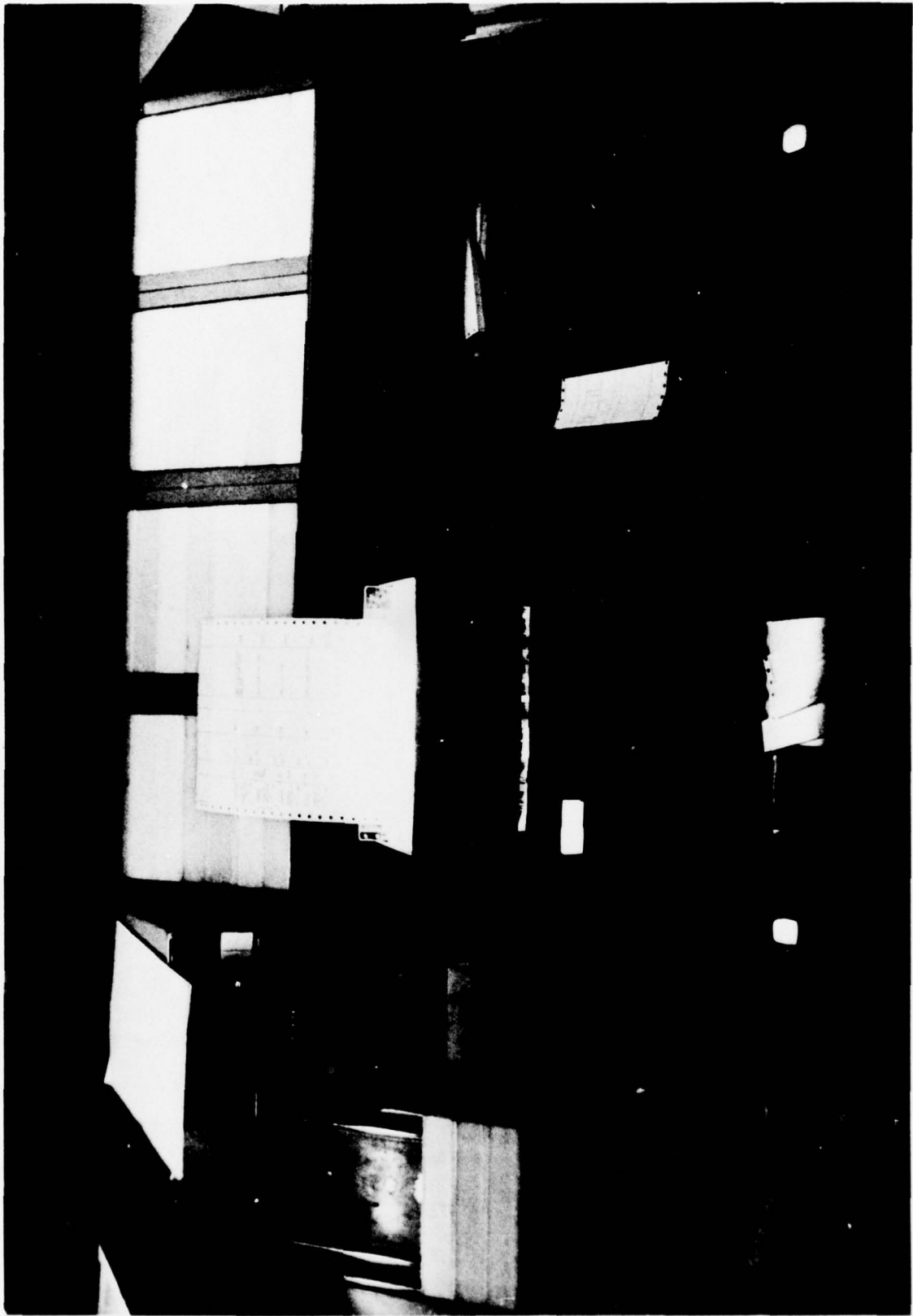

FIGURE 2.7 - PRINTER GLARE SOURCES

### 3.0 FIELD INVESTIGATIONS

#### 3.1 Purpose

The Atlanta, Cleveland and Washington ARTCCs were visited in an attempt to identify all the sources of reflections on the PVD to determine if ARTCCs were experiencing common problems, to identify possible differences in control room arrangements, to make comparative measurements of the lighting conditions at each of the ARTCCs and to obtain suggestions from Center personnel in solving the problem.

The primary sources of glare and reflection onto the face of the PVD were due to the ambient illumination, the map board and the flight strips. The specific details of each are covered in the following paragraphs.

#### 3.2 Ambient Illumination

The ambient illumination in the ARTCCs consists of five principal components: the overhead lights which are seldom used and are, therefore, not a significant factor; the indirect lighting emanating from the four rows of plenums; stray light from the map boards; reflected light from the flight strip charts; and stray light from the supervisor's position. The differences in the overall ambient illumination of the three Centers visited, as well as the Boston ARTCC, were due to variations in illumination of map boards and flight strips rather than the plenums. Extinguishing the indirect lighting emanating from the plenums located along the walls did not significantly reduce the ambient room illumination, but did remove the wall reflection from the PVDs located in the center of the room. Increasing the output of the lights in the center plenum provided a

50% increase in ambient room illumination in Atlanta, Cleveland, and Boston without significantly increasing the ceiling reflection seen in the PVDs along the walls. Comparative mean illumination readings for the four Centers is provided in Table 3.1 to show the variations from center to center. Of those visited, only the Atlanta Center appeared to have adequate control over the plenum lights. In no case, were the illumination sources balanced so that equal ambient illumination could be provided. In addition, in all cases a number of plenum lights were not operable. If adequate ambient illumination with minimal reflection is to be provided, all lamps must be operable and balanced.

In both Atlanta and Cleveland, the supervisors' positions are located too close to the controllers' positions. The lamps on the supervisors' desks cast considerable stray and direct light on the controllers' positions at the front of the room. The supervisors' positions should be moved back and desk lamps with deeper shades provided to prevent direct illumination from reaching the controllers. Five possible lamps to be used on the supervisors' desks were identified for evaluation at the Boston Center.

### 3.3 Map Board Illumination

The 3M Light Control Film sample was tried on the map boards. It appears that the 18° angle film with a 3.5 to 1 aspect ratio will provide both the Controller and Supervisor from their positions in the control room with visual access to the map board and, at the same time, eliminate the reflection of the map board on the PVD across the aisle. The 30° angle film allows only the controller to view the map board.

The light control film is a thin plastic sheet incorporating black microlouvers which work like venetian blinds to control light and viewing angle.

TABLE 3.1  
COMPARATIVE MEAN ILLUMINATION READINGS AT ARTC CENTERS

	<u>BOSTON</u>	<u>WASHINGTON</u>	<u>ATLANTA</u>	<u>CLEVELAND</u>
1. Ambient Illumination in Aisle	0.13 ft-c	0.13 ft-c	0.38 ft-c <sup>1</sup>	0.38 ft-c <sup>1</sup>
2. Flight Strip Illumination	10.0 ft-c	10.0 ft-c	8.0 ft-c	10.4 ft-c
3. Flight Strip Surface	19.1 ft-L	5.1 ft-L	9.8 ft-L	5.4 ft-L
4. Plenum Illumination	0.50 ft-c <sup>4</sup>	0.90 ft-c	2.1 ft-c <sup>2</sup>	0.32 ft-c <sup>4</sup>
5. Canopy Indicator Lamps	7.2 ft-L	11.0 ft-L	7.2 ft-L	7.2 ft-L
6. Supervisor's Desk Surface	27.6 ft-L	25.2 ft-L	14.5 ft-L <sup>3</sup>	28.9 ft-L
7. Printer Paper Illumination	79.0 ft-L	81.8 ft-L	40.9 ft-L	50.3 ft-L
8. Printer Indicator Lamps	50.5 ft-L	25.2 ft-L	28.9 ft-L	36.1 ft-L
9. PVD Indicators	0.60 ft-L	0.32 ft-L	6.3 ft-L	1.3 ft-L
10. Typewriter Lamps	2.2 ft-L	2.0 ft-L	0.64 ft-L	2.2 ft-L
11. Map Board Illumination	7.2 ft-L	6.4 ft-L	6.0 ft-L	5.4 ft-L

<sup>1</sup>Increased Ambient Levels to .75 ft-c.

<sup>2</sup>Increased Illumination to 2.6 ft-L.

<sup>3</sup>Glass Cover Not Used On Supervisor's Desk

<sup>4</sup>Increased Illumination to 1.3 ft-c.

When placed in front of a lighted display, it directs light into a controlled viewing pattern and blocks out light from external ambient sources. The louver angle directs the angle of light transmitted through the film while the view angle is determined by the spacing between the louvers. This is shown in Figure 3.1.

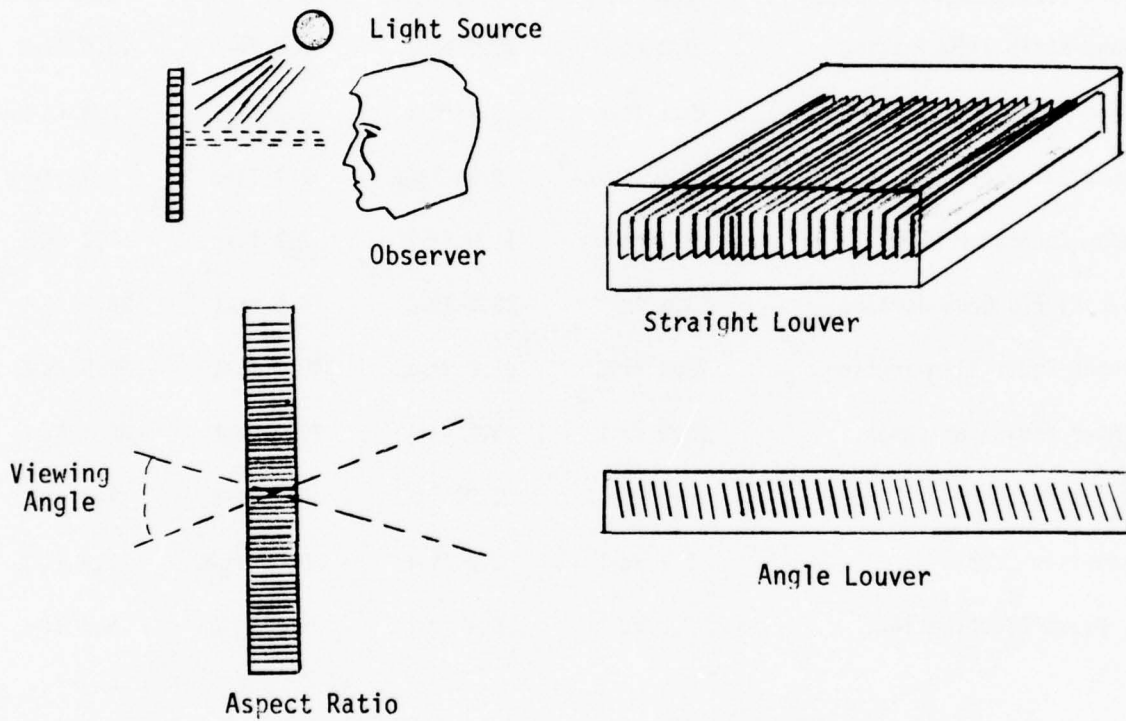

FIGURE 3.1 - 3M LIGHT CONTROL FILM OPERATION

In a subsequent meeting with 3M Company at the Minneapolis ARTCC, larger pieces of the 3M Light Control Film were tried. This investigation demonstrated that the ideal choice is the 18° opaque black louver with a 3.5 to 1 aspect ratio. In order to cover the map board, two pieces, 10-3/8 x 33 in. are required. These pieces are taped directly behind the clear plastic map board cover. Use of this specific light control film provides an unlimited view of the map board to the controller, a black non-reflecting surface to the controller at the opposing PVD and an unobstructed view of the upper 4/5 of the map board to the supervisor. In order to view the lower 1/5 of the map board, the supervisor must bend forward slightly. Since the light control film focuses the light from the map board to the center of the aisle, this should increase the ambient illumination of the ARTCC.

#### 3.4 Flight Strip Illumination

There is a wide variation in the illumination setting of the flight strips between controllers. This was observed at all Centers. When the illumination is high, three problems exist. First, the reflection in the PVD on the opposite side of the room is distracting. Second, the Radar controller shifting his attention back and forth from the relatively dark PVD to the bright flight strip chart may suffer eye muscle fatigue. Third, the light from the flight strip lamp spills over onto the PVD. When the flight strip lighting is lowered to a degree which minimizes these problems, the strips can no longer be easily read.

### 3.5 Summary

All of the visited Centers agreed that the reflection problem exists, but none had any suggestions describing how to alleviate the problem. There were a few isolated comments from controllers concerning eye strain and headaches. The general consensus among controllers volunteering opinions was that the reflections on the PVD is a problem, but they have learned to live with it. Utilization of the light control film was demonstrated at all Centers, and there was general agreement that it appeared to solve the map board reflection problem. The ambient illumination and flight strip problems required a more extensive investigation and these subjects are covered in the following sections of this study.

#### 4.0 SUMMARY OF LITERATURE RESEARCH

A separate report synthesizing the available literature in the areas of glare and reflection as related to the ARTCC environment was completed and is in Appendix C of this Final Report. Although some 150 reports were found dealing with glare and reflection, only 32 applied either directly or indirectly to the ARTCC lighting problem. The majority of the literature was found to address the problems of veiling rather than specular reflection. The following paragraphs summarize the more pertinent results of the literature search.

##### 4.1 Circular Polarizers

Circular polarizers effectively reduce specular reflections from the face of a CRT screen. However, they cause several secondary problems: (1) they are useful only for limited ranges of the light spectrum; (2) they reduce the transmittance of the light from the screen to the observer; (3) specular reflections appear on the face of the circular polarizer itself and, (4) they are very expensive. Colman et.al. (1958) attempted to design an invisible glass shield to be placed over the circular polarizer in order to eliminate these specular reflections. This seems to complicate the problem rather than solve it because it does not eliminate the problem of limited spectrum range of polarizers, and the glass introduces problems of parallax.

##### 4.2 Wire Mesh Filters

Wire mesh techniques effectively eliminate specular reflection problems but, under the low ambient conditions found in the ARTCC control centers, wire mesh filters lower the transmittance of light to unacceptable levels.

#### 4.3 Color/Neutral Filters

Color/neutral filters effectively increase the contrast between the characters and the screen background. However, by themselves they do nothing to eliminate specular reflection problems.

#### 4.4 Etches

Etches tend to eliminate specular reflections, but unless the etching is carefully controlled, it may cause unacceptable losses in character resolution, thereby leading to eye fatigue due to the loss in display legibility.

#### 4.5 Optical Coating

Optical coatings probably provide the best method of reducing specular reflections. Hampton and Carr (1967) determined that glass coated on both sides by an Optical Coating Laboratory HEA coating provides the most efficient coating available. But inherent problems with coatings still exist: (1) they do not reduce non-specular reflections; (2) they are susceptible to loss of resolution by oily films and fingerprints; (3) they are not resistant to abrasion; (4) they are viewing-angle sensitive.

#### 4.6 Etching and Optical Coating

The process developed by Spanier et al (1972) combining etching and optical coatings is a first step to answering this problem of reflections on the PVD face. This process apparently eliminates all the objections to etching. It also eliminates most of the problems associated with optical coatings with the exception of applicability to non-glass surfaces. If the non-glass implosion shield can successfully be placed between the face of the CRT and the faceplate, the process will show considerable merit.

#### 4.7 Ambient Lighting

In addition to the specular reflection problem there is also a problem of the ambient lighting in the environment. The recommendations of the Parsons' Report (1970) for control room lighting have not been followed in their entirety. Also, the Parsons' Report does not deal adequately with the entire PVD reflection problem. The ambient room lighting must be balanced to eliminate the light/dark contrasts found on the walls and ceiling. The present general lighting installations are incapable of being balanced effectively and persist in causing specular reflections on the PVD face.

## 5.0 EVALUATION PROCEDURE

### 5.1 Description of Test Facility

Area D of the Boston ARTCC was designated by the FAA as the test facility for this lighting study. This area is located at the rear of the right side of the control room and consists of 12 display positions, 6 on each side of the room. The 6 positions are numbered 15 through 20 at the center of the room and 1 through 6 along the right wall. Table 5.1 presents the potential improvements for each of the problem areas and Figure 5.1 is a schematic diagram of the experimental area showing the location of the improvements to be evaluated in this study. Each of these improvements is discussed in Section 5.2.

### 5.2 Description of Potential Improvements

#### 5.2.1 Ambient Illumination

A new set of dimmer controls was installed to control the plenum lights in Area D. At the same time, the fluorescent bulbs and ballasts were checked to insure proper operation. One Superior Electric, Model No. LFD-10A dimmer controls the eight fixtures on each side of Area D. This provided a continuous control over the ambient illumination. The indirect ambient was set at 1.3 foot-Lamberts (ftL) as measured off the ceiling of the control room. This brightness was the maximum setting that could be obtained without having distracting wall and ceiling reflections on the PVD.

In order to increase the illumination on the floor in the aisle, under-desk lights were installed. These consisted of four-foot fluorescent fixtures with single 30 watt Vita-Lite lamps under each of the M-1 Consoles at positions 1, 2, 15 and 16.

TABLE 5.1 - POTENTIAL IMPROVEMENTS

PROBLEM	EVALUATION CONDITIONS		
	Control <sup>1</sup>	Balanced	-
Ambient Illumination	Control <sup>1</sup>	Balanced	-
Map Board	Control	Timer	Negative "Black Maps" Film
Flight Strips	Control	Mechanical Louvers	Louvers and Light Control Film
PVD Console Pushbuttons	Control	Photo-Negative	-
Printer Illumination	Control	Green Filter	Gray Filter
Printer Pushbuttons	Control	Green Filter	Gray Filter
Supervisors' Desk Lamp	Electrix Petite	Electrix Classic	Luxo Crownlight Student
Desk Surface	No Baffle	Baffle	-

<sup>1</sup>Control condition is the present unmodified equipment as found in ARTCCs.



### 5.2.2 Map Board Reflection

In order to eliminate the map board reflections on the PVD, the following improvements were installed for evaluation: The location of each is shown in Figure 5.1.

1. An AMF Model No. CHB-38-70013 variable timer was installed in the lighting circuit of the map boards over positions 17 and 18. This is designated as  $M_T$  on Figure 5.1. The variable timer could be set to illuminate the map board at an interval from 1 to 80 seconds after the controller activated a switch. The rationale for the timer was that the reflection of the map board would be eliminated at all times when the controller was not using the map board.
2. A second possible improvement in the map board illumination was the use of photo-negative "black" maps, shown in Figure 2, similar to those installed at the Los Angeles ARTCC. In its simplest form, these are white lines on a black background. The "black" maps were installed in positions 5, 6, 19 and 20. The rationale for the "black" maps was that since the majority of its area was black and opaque, the reflection on the opposing PVD would be minimized while still retaining map legibility.
3. The third potential improvement was the installation of 3M Company Light Control Film. After preliminary tests, the optimal type to be employed consisted of two pieces of 10-3/8 x 33 in., 18° black louver with a 3.5:1 aspect ratio, clear, glossy and taped to the rear of the plastic cover

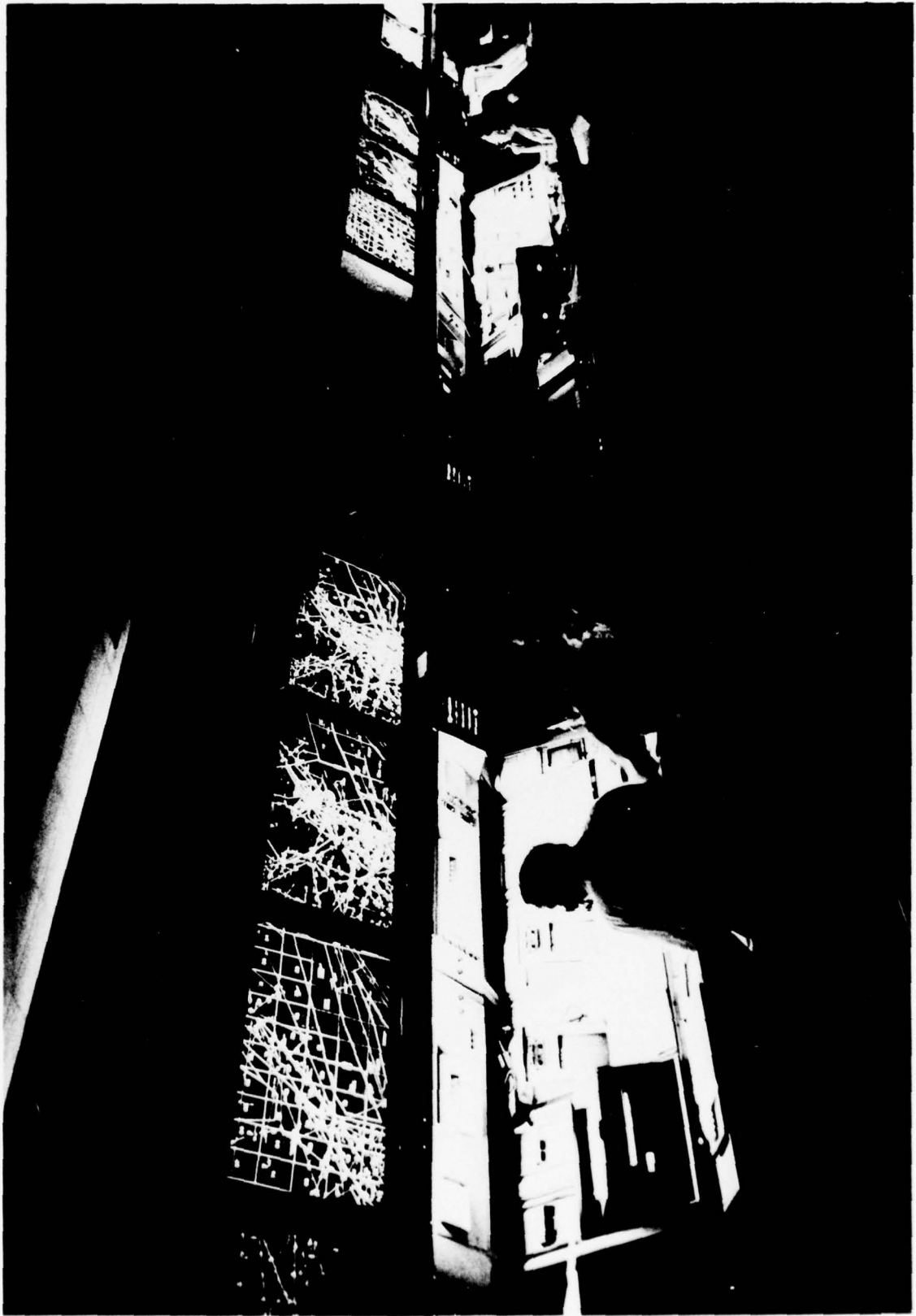

FIGURE 5.2 - "BLACK" MAP INSTALLED IN TEST AREA

located over the map. This is shown in Figure 5.3. The rationale for use of the light control film was that the controller and supervisor would be able to view the map, but the black louvers imbedded in the film would eliminate the majority of the light which is normally reflected onto the face of the opposing PVD. Six map boards in positions 1, 2, and 16 were selected for the evaluation of the light control film.

4. The remaining map boards contained the standard maps for baseline data and comparison in evaluating the above improvements.

### 5.2.3 Flight Strip Illumination

In order to relieve both the glare and reflection problems associated with the M-1 Flight Strip Console, the following improvements were chosen for evaluation.

1. The flight strips marked "F" on Figure 5.1 were designated as controls for this evaluation. They contained only the fluorescent lamps.
2. The flight strips designated "F<sub>L</sub>" contained the standard 1/2-inch, in-depth, black egg-crate metal louvers.
3. The flight strips marked "F<sub>X</sub>" contained both the black louver cited above and a 3-1/4" x 36" piece of vertically louvered light control film with 30° black, clear, glossy louvers with a 2.75:1 aspect ratio mounted between the



FIGURE 5.3 - COMPARISON OF STANDARD AND LIGHT CONTROL FILM MAP BOARDS

fluorescent bulb and the louver. Early in the evaluation, it was found that the 36-inch piece of light control film caused too great a reduction in illumination of the flight strip. Therefore, the last 12 inches farthest from the PVD were removed. Removing this piece succeeded in increasing the illumination of the flight strips to an acceptable level, and the 3-1/4 x 24 inch piece of light control film was used in the evaluation.

#### 5.2.4 PVD Console Pushbuttons and Indicators

In order to reduce the glare being emitted by the pushbuttons and indicators on the PVD console, the standard keycaps located on the PVDs located at positions 2, 5, 6, and 16 through 20 were replaced with photo-negative legends. The photo-negative legends consist of a black background with clear letters; therefore, the lamp behind the keycaps illuminates the legend only. Measurements of the difference in intensity between the standard keycap legends and the negative keycap legends were made.

#### 5.2.5 Printer Illumination

The printer provides two separate and distinct sources of glare:  
1) the top of the printer where the printed flight strips are illuminated and  
2) the READY and FIRST LINE indicators on the front of the printer.

To find an adequate solution to the glare emanating from the top of the printer, the following potential improvements were evaluated:

1. The printers labeled P<sup>C</sup> located at position 19, as shown in Figure 5.1, were used as controls with no added improvements.

2. Printers at positions 1, 16, 18 were fitted with a gray filter,  $P^{DE}$ , between the lamp and the printed flight strip to reduce the glare.
3. Printers located at positions 2, 5, 6, 15, 17, and 20 were fitted with a green filter,  $P^{AB}$ , between the lamp and the flight strip.

In order to reduce the glare from the printer indicators, the following potential improvements were evaluated:

1. Those printers labeled  $P_C$  located at positions 2, 6, and 15 served as controls.
2. Printers located at positions 16, and 18 were fitted with a gray filter,  $P_{GY}$ , over the indicators.
3. A green filter,  $P_{GN}$ , was placed over the printer indicators located at position 17.
4. Three layers of self adhesive 3 mil Light Diffusing Film, made by the 3M Company, were placed on printer indicators located at positions 5, 19, and 20.

#### 5.2.6 Supervisor's Desk

To eliminate the glare emitted at the supervisor's desk, the following improvements were evaluated:

1. A black wooden baffle 10 inches in height was placed around three sides of the supervisor's desk in Area D.

2. Five different types of lamps were purchased for evaluation on the supervisor's desks. Although the lamps were different in illuminating source, shape and construction, each had a shade deep enough to prevent direct illumination from reaching the controllers. In the control room, one of the lamps was placed on each of the four supervisors' desks and the fifth on a desk in the rear. The lamp at Area A was an Electrix Petite Lamp with a high intensity bulb. Area B had an Electrix Classic with a conventional 40 watt bulb. Area C had a Luxo-Crownlight Student Lamp with a conventional 40 watt bulb. Area D had a Tensor Model 6500 Lamp with a high intensity bulb. The remaining lamp was a Tensor Model 450 Lamp with a high intensity bulb.

### 5.3 Evaluation Criteria

A set of four criteria was developed for the evaluation of the proposed ARTCC lighting improvements.

1. Lighting measurements - At least a 40% reduction in brightness shall be achieved for the map boards, flight strip glare, printers and supervisors desk. At least a 40% increase shall be achieved in the overall ARTCC ambient illumination.
2. Recommendations of experts - The expert recommendations of Human Factors, Environmental and Medical personnel, are based upon the photometric measurements, their evaluation of the lighting improvements and interviews with the Controllers.
3. Acceptability of the improvements in lighting as seen by ARTCC supervisory personnel in response to the questionnaire.
4. Acceptability of the various improvements as seen by the Controllers in response to the questionnaire.

### 5.4 Photometric Measurements

#### 5.4.1 Photometric Test Equipment

All measurements of reflected light taken at the Boston ARTCC were made using a Gamma Scientific Model 2000 Telephotometer using a 20 minute aperture. The Telephotometer was calibrated prior to taking the measurements using the internal calibrator. Direct measurements of the intensity of the ambient illumination were made with a Gossen Lunasix light meter using the diffuser lens and the measurement was converted to foot-candles. Measurements made with the tele-

photometer have an accuracy of  $\pm 1\%$  and those made with the Lunasix have an accuracy of approximately 10% due primarily to errors inherent in the logarithmic conversion process of the readings to foot-candles.

#### 5.4.2 Description of Measurements

The types of photometric measurements are summarized in Table 5.2 and the points at which the measurements were taken are presented in Figures 5.4 through 5.8. The specific values for each of these measurements are presented in Appendix A.

Measurements of the ambient illumination are shown in Figure 5.4. The "x's" denote the point of measurement and the circled numbers define the type of measurement taken. Measurements 1 through 6 were all taken one foot from the floor in the center of the aisle. Measurements 7 through 9 were taken five feet from the floor at the center of the aisle. Measurement 10 is the measurement of the light reflected off the ceiling by the balanced plenum lights. Measurements 11 and 12 are the intensity of the under-desk fixtures.

The position of the measurements of all map board improvements evaluated is shown in Figure 5.5. The flight strip measurements are shown in Figure 5.6. The measurements taken on the PVD console are presented in Figure 5.7 and the printer measurements in Figure 5.8.

The following reflection measurements were taken off of the PVD safety glass: the map board, the flight strips, the ceiling or wall, the printer, the speaker bezel and a piece of white cardboard held 18" from the PVD face. Values were recorded of the present conditions and the proposed improvements.

TABLE 5.2

SUMMARY OF PHOTOMETRIC MEASUREMENTS

- A. Ambient Illumination
  - 1. Normal ambient (control condition)
  - 2. Ambient with under-desk lights
  - 3. Ambient with light control film on map boards
  - 4. Ambient with balanced plenum illumination
  - 5. Intensity of under-desk lamps
- B. Map Boards
  - 1. Standard Map Board (control condition)
  - 2. Photo-negative map ("black map")
  - 3. Light control film over map board
- C. Flight Strips
  - 1. No louver in fixture (control condition)
  - 2. Louver in
  - 3. Louver and light control film
- D. PVD Console
  - 1. Standard keycap legends (control condition)
  - 2. Photo-negative keycap legend
- E. Printer
  - 1. Standard printer illumination (control condition)
  - 2. Green filter
  - 3. Gray filter
  - 4. Standard printer indicators (control condition)
  - 5. Green filter over indicators
  - 6. Gray filter over indicators
  - 7. Light diffusing material under indicators
- F. Reflection on PVD
  - 1. No reflection on PVD (control condition)
  - 2. Map Board
  - 3. Flight Strips
  - 4. Ceiling or Wall
  - 5. Operator
  - 6. Speaker Bezel

x 10

x 10

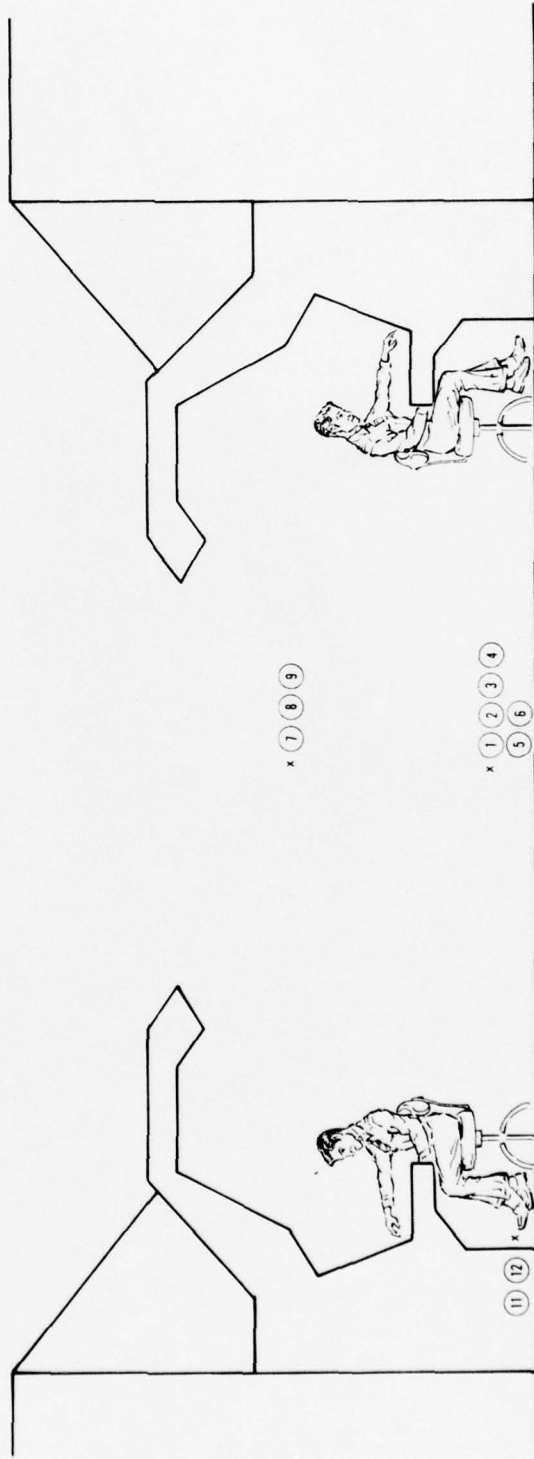

FIGURE 5.4 - AMBIENT ILLUMINATION MEASUREMENTS

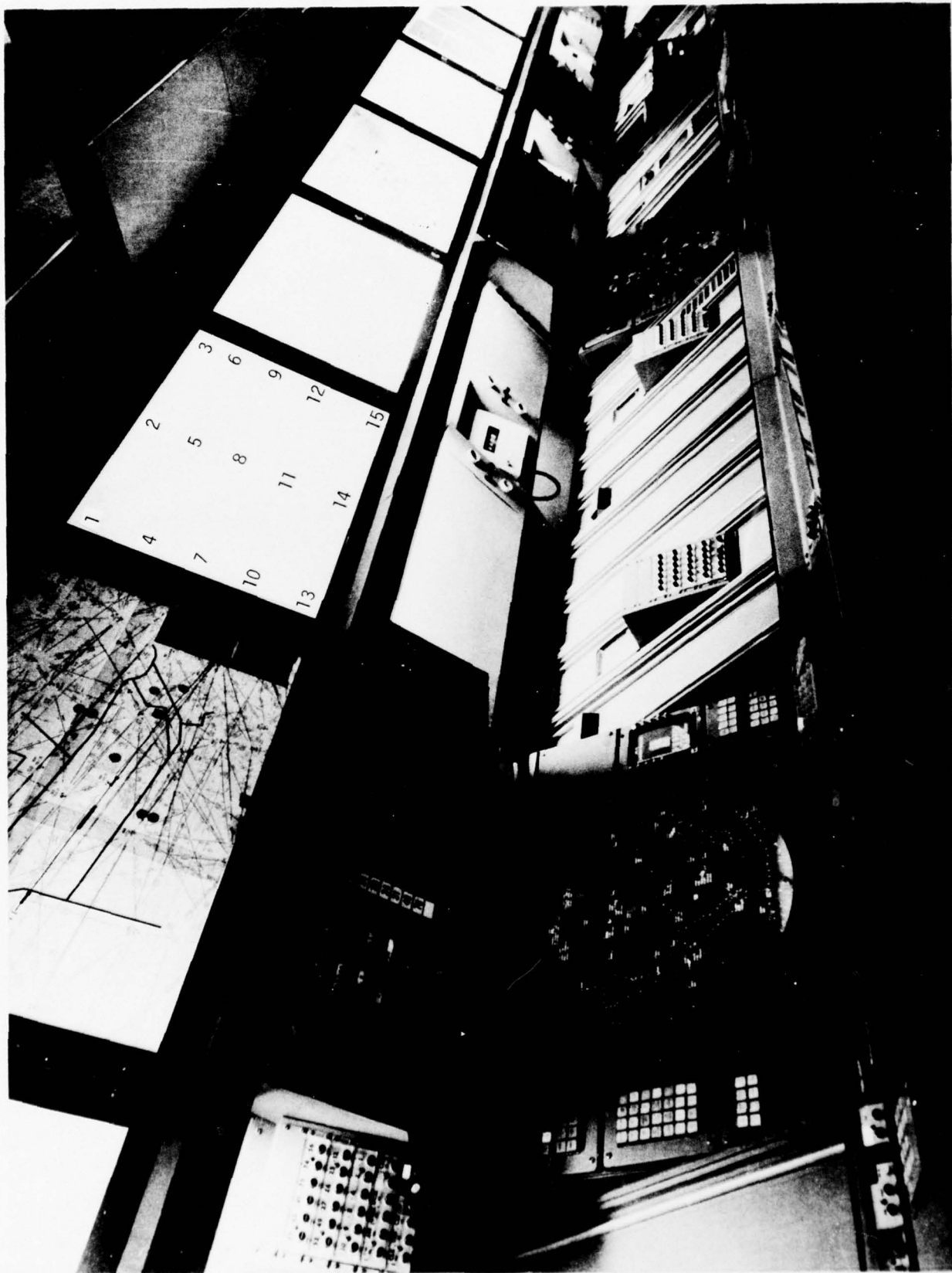

FIGURE 5.5 - MAP BOARD MEASUREMENT POINTS

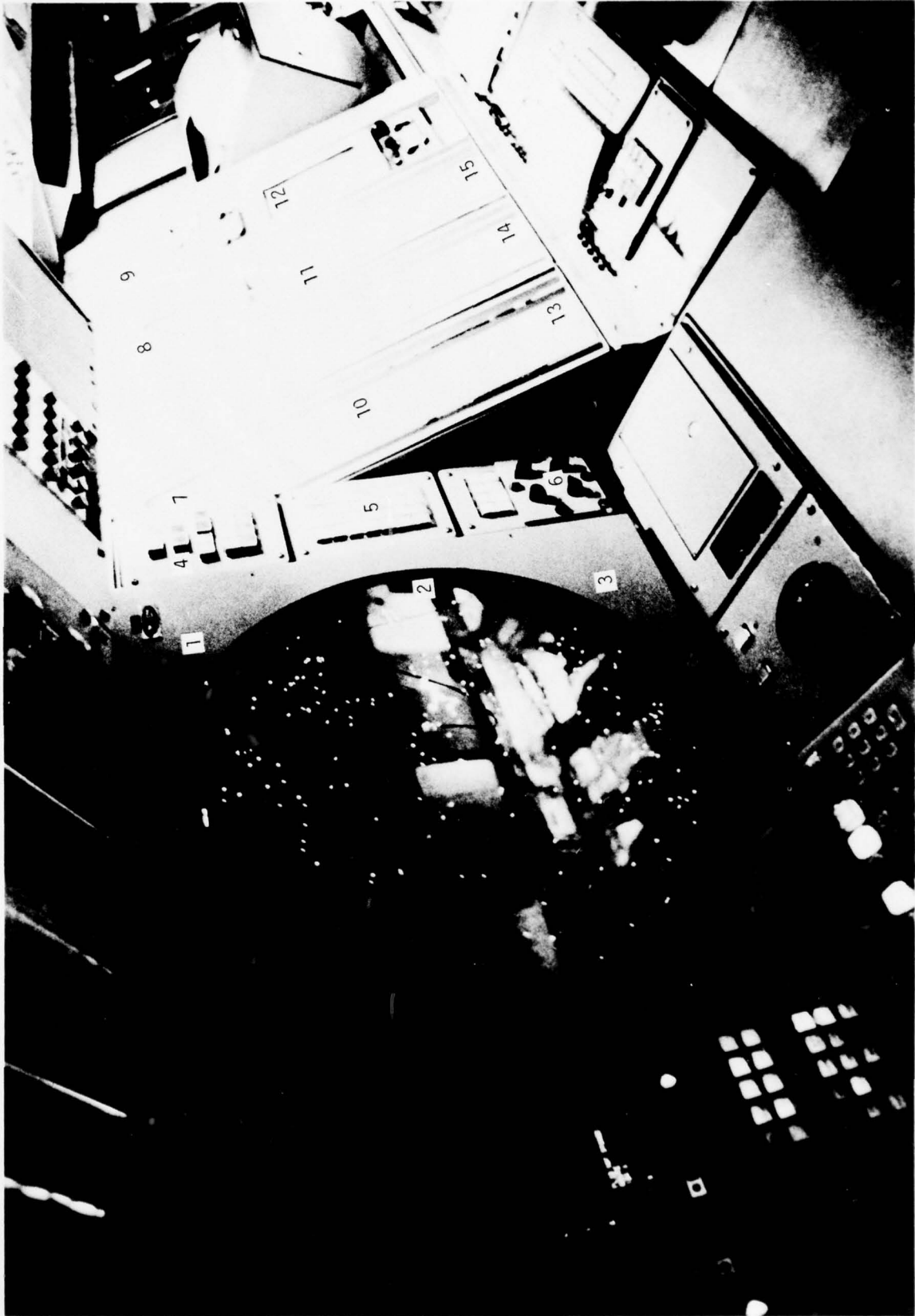

FIGURE 5.6 - FLIGHT STRIP MEASUREMENT POINTS

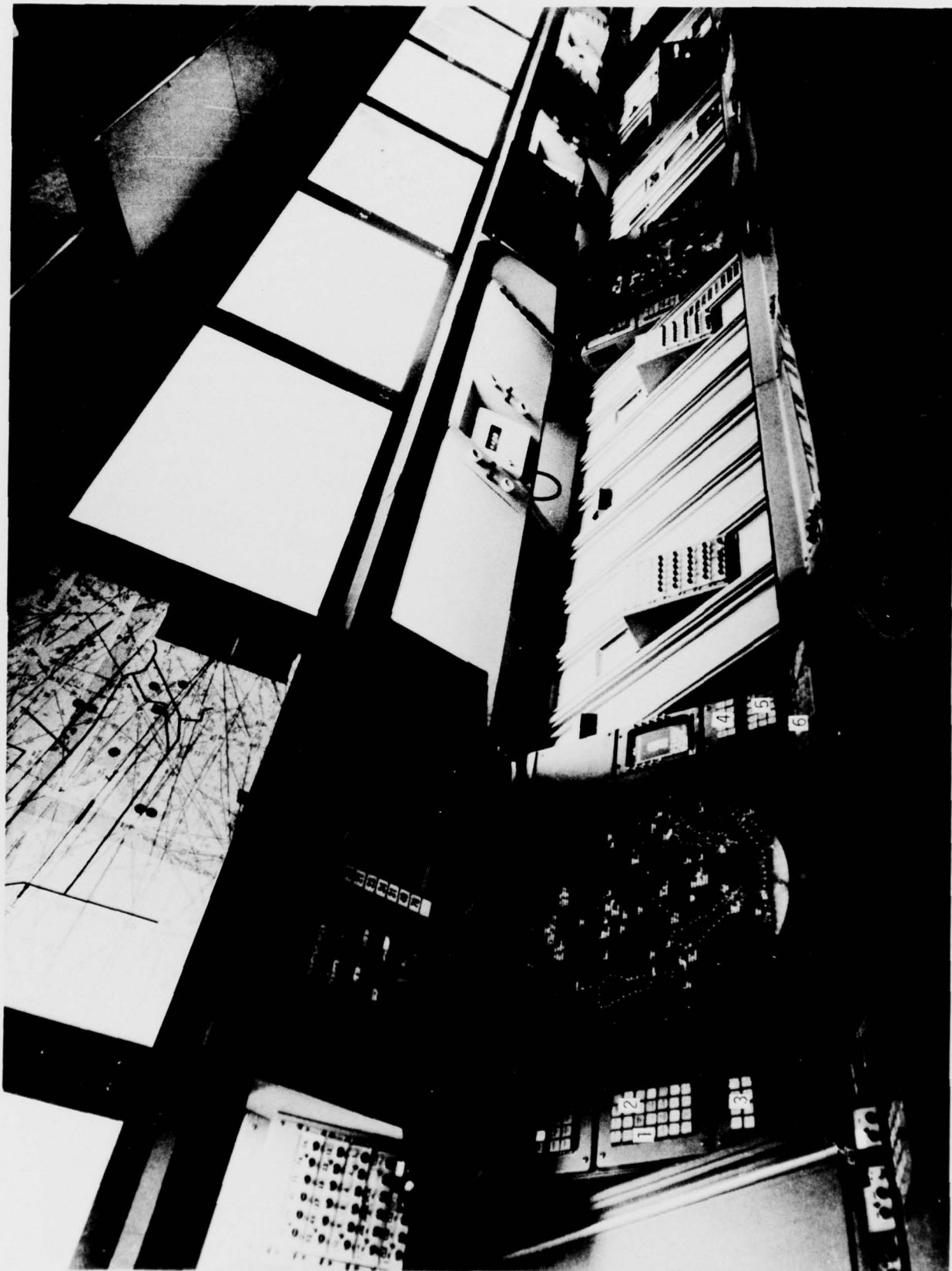

FIGURE 5.7 - PVD CONSOLE MEASUREMENT POINTS

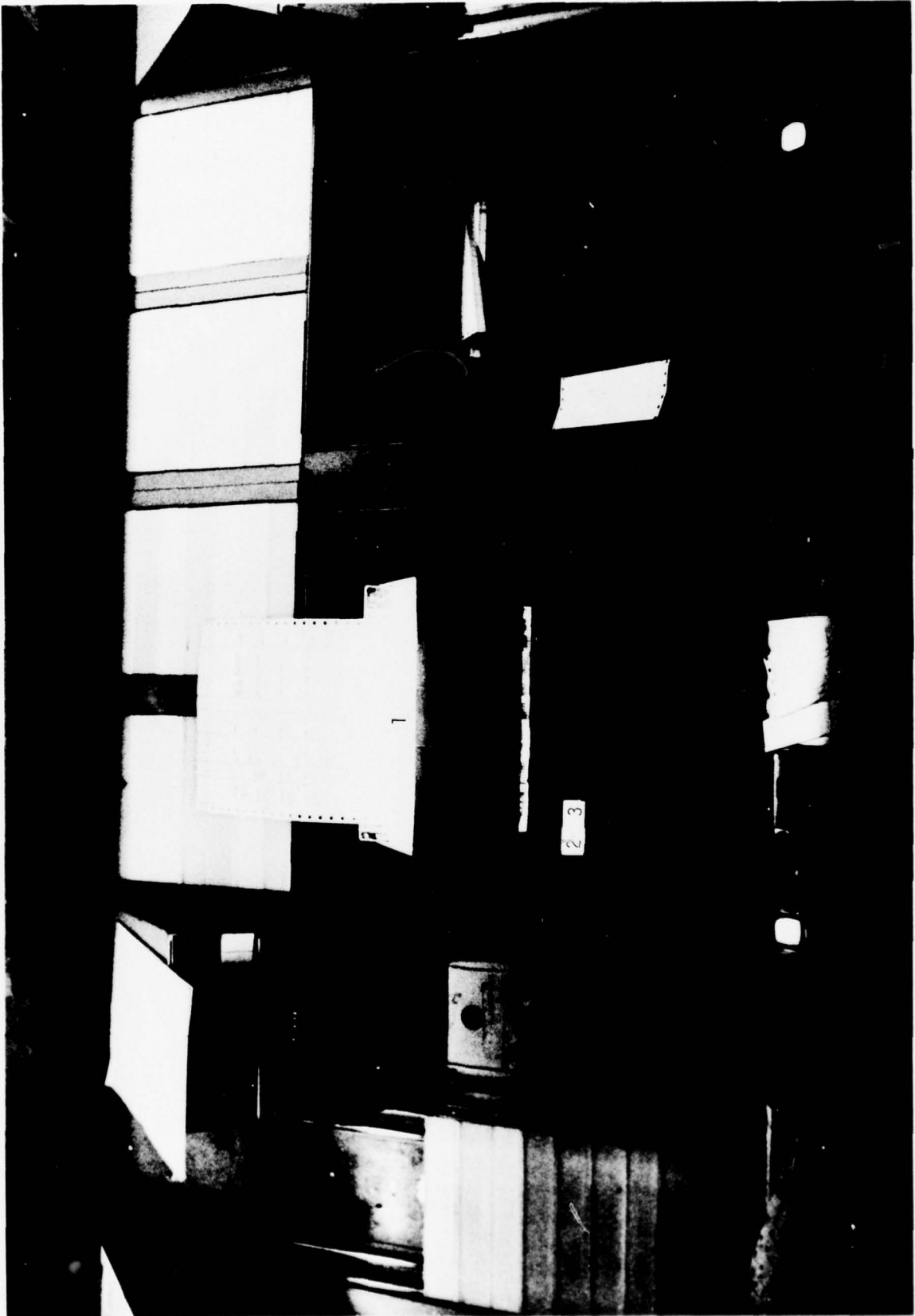

FIGURE 5.8 - PRINTER MEASUREMENT POINTS

### 5.5 Subjective Evaluation Procedure

The evaluation questionnaire presented in Appendix B was developed by NAFEC to obtain a subjective evaluation of the changes implemented in Area D. The questionnaire was distributed to a group of 31 controllers, area supervisors working on any of the three daily shifts, and supervisory personnel familiar with the purpose of this study. Additionally, 10 of the controllers were randomly selected for a post-questionnaire interview. The questionnaire contained 17 questions. Questions 1-6 required a choice of two alternatives and dealt with general attitudes concerning the reflection problem and the evaluation of the under-desk lamps. Questions 7-13 dealt with the evaluation of specific potential improvements. A five point rating scale was employed in this case. Question 14 was not answered since it was not possible to implement the nylon mesh cover on the CRT. Questions 15-17 consisted of short essay response concerning further suggestions for improvement, a reaction to the implemented changes and an overall evaluation of the potential improvements and evaluation procedure.

## 6.0 RESULTS

### 6.1 Photometric Measurements

All of the photometric measurements made in this study are presented in Appendix A. This section summarizes these measurements and describes the degree of improvement obtained by each of the potential improvements at the Boston ARTCC.

#### 6.1.1. Ambient Illumination

At the onset of the evaluation, the ambient illumination at the center of the aisle measured 0.13 ft-c at a height of one-foot from the floor. This level of illumination made it quite difficult to avoid any obstacles close to the floor when walking down the aisle and made it impossible to read any written material. Balancing the plenum illumination by use of the new dimmer controls to 1.3 ft-L on the ceiling made it possible to increase the ambient illumination to 0.32 ft-c at the same one-foot height from the floor while maintaining acceptable limits to the wall and ceiling reflections. The effective use of these dimmer controls increased the aisle illumination by a factor of approximately 2.5.

The addition of the light control film over the map boards focuses the light from the map boards towards the center of the aisle. The illumination in the center of the aisle was thereby increased to 0.75 ft-c. This represents a factor of 5.75 over the original measurement of 0.13 ft-c.

The under-desk fixtures, when illuminated to maximum intensity (97.0 ft-c), provided 1.5 ft-c to the center of the aisle, but were distracting sources of glare to the controllers. When the intensity was reduced (16 ft-c), they provided only 0.75 ft-c. Since this value is equivalent to that provided by

the map boards, the under-desk lamps appear to be unnecessary. Also, as installed, they are a potential safety hazard since there is nothing to prevent the controller from accidentally kicking the fixture and breaking the bulb.

The use of Luxor Vita-Lite fluorescents rather than Cool White in the plenums, map boards, and flight strip fixtures is recommended. The Vita-Lite bulb more closely simulates natural outdoor light while the Cool White casts a highly discernible yellow color.

#### 6.1.2 Map Boards

A total of fifteen measurements were taken across the face of a map board. The mean brightness measured across the standard map board presently in use was 30.5 ft-L. The mean brightness of the photo-negative map was 5.1 ft-L taking into account both black and white areas. Therefore, photo-negative maps provide a six-fold decrease in illumination. When the light control film was placed over the maps, a mean brightness at the controller's position was 17.6 ft-L and only 0.4 ft-L at the opposing console on the other side of the aisle. The light control film provides more than adequate illumination of the map at the controller's position and effectively removes the reflection of the map board on the opposing PVD.

#### 6.1.3 Flight Strips

Six measurements were taken on the PVD console. The mean amount of stray light falling on the PVD from the flight strips without louvers was 6.1 ft-L. Nine measurements were taken on the flight strip area and a mean brightness of 34.9 ft-L was obtained. The addition of the standard 1/2 inch

louver lowered the stray illumination on the PVD console to 1.4 ft-L and to 19.1 ft-L on the flight strips. Inclusion of the light control film reduced the stray light on the PVD console to 0.27 ft-L but, at the same time, also reduced the illumination of the flight strip area to 2.7 ft-L which is just adequate for legibility of the flight strips. The substitution of the Vita-Lite fluorescent lamp for the Cool White lamp appeared to increase legibility of the flight strips. However, this substitution was made after the formal evaluation and no photometric measurements were made. The aluminum bezel on the speaker located on the flight strip area is a glare source, (89.0 ft-L) and should be painted a matte black.

#### 6.1.4 PVD Console

There is approximately a two order-of-magnitude difference in the illumination of the PVD pushbuttons from one side of the console to the other. The positive keys (clear background with black letters) had a mean brightness of 33 ft-L on one side and 0.5 ft-L on the other. The negative keys (black background with clear letters) had a mean brightness of 0.2 ft-L on either side. The negative pushbutton legends provide an adequate illumination for the controller in terms of both visual comfort and visibility.

Photometric measurements were made of the reflections directly on the PVD. Where no reflections existed on the PVD, the background brightness measured 0.17 ft-L. The standard map board provided a reflection brightness of 0.64 f-L while the map board covered with the light control film measured 0.18 ft-L, which is negligibly different from the background. The uncovered flight strip measured 1.60 ft-L which was reduced to 0.42 ft-L when the louvers and light control film were added. The addition of the louvers and light control film appears to provide a significant reduction in the reflection

brightness. When the plenum lights were set at a brightness level of 1.3 ft-L at the ceiling, the ceiling reflection measured 0.25 ft-L which is well within the controller's tolerance limits for reflection. The operator himself casts a reflection measuring 0.20 ft-L on the face of the PVD. The aluminum speaker bezel provided the greatest reflection on the PVD measuring 2.1 ft-L.

#### 6.1.5 Printer Illumination

Measurements of the illumination of the printer paper were made using the standard clear plexiglass, a green plexiglass filter, and a gray plexiglass filter. The values were 77.0 ft-L, 8.1 ft-L, and 23.0 ft-L, respectively. These measurements demonstrate that the green filter is most effective and in the testing provided approximately a ten-fold reduction in printer illumination while retaining adequate legibility of the flight strip printing.

The printer indicators were measured with no filter, a green filter, a gray filter, and 9 mils of 3M light diffusing material. The average measurements of brightness for the two indicators were 50.5 ft-L, 9.5 ft-L, 21.5 ft-L, and 19.0 ft-L respectively. The green filter provided the maximum brightness reduction.

#### 6.2 Subjective Evaluation

The evaluation questionnaire is presented in Appendix B. A total of 31 supervisors and controllers responded to the questionnaire. Since all respondents did not answer all questions, all dichotomous questions are summarized in percentages of agreement. Where the respondent was presented with five choices, the responses were scaled on the following five point scale and averaged to

obtain a mean ranking.

Excellent	5
Good	4
Fair	3
Poor	2
Bad	1

The last three questions called for controller comments. These are summarized and discussed in Section 7.0. The results of the evaluation questionnaire by item are as follows:

1. Needed improvements
  - a. Reflections on PVD 97%
  - b. Glare sources 83%
  - c. Stray light from flight strips 76%
  - d. Overall aisle lighting 93%
2. Effectiveness of improvements
  - a. Reflection on PVD 77%
  - b. Glare sources 68%
  - c. Stray light 73%
  - d. Overall aisle lighting 59%
3. Satisfaction with improvements
  - a. General aisle lighting 57%
  - b. Flight strip illumination 46%
  - c. Map board lighting 88%
  - d. PVD indicators 74%
  - e. Printer 91%
  - f. Shelf area of PVD 81%
  - g. General working area for D men 37%
  - h. General working area for A men 58%

4. Importance of high level of ambient lighting
  - a. Ambient should be lower 29%
  - b. Ambient should be where it is 29%
  - c. Ambient should be increased 42%
  
5. Relationship between controller task and ambient light level
  - a. Radar controllers need a dimly lighted control room 50%
  - b. Manual controllers need a low light level also 18%
  - c. Assistant controllers prefer more light 78%
  - d. Floor supervisors prefer more light than R-men 81%
  - e. Managers prefer a control room with more light 67%
  
6. Evaluation of under-desk "knee lights" to reduce reflection
  - a. With knee lights and less wall light, reflections are down 61%
  
7. Evaluation of map board modifications
  - a. Preferred method
 

timing switch	7%
light control film	79%
"black maps"	14%
  - b. Ranking
 

timing switch	2.2
light control film	3.7
"black maps"	2.6
  
8. Evaluation of flight strips
  - a. Preferred method
 

no louvers	8%
louvers	40%
louvers with light control film	52%
  - b. Ranking
 

no louvers	2.7
louvers	3.3
louvers and light control film	3.1

9. Evaluation of printer indicators
- a. Preferred method
- |                      |     |
|----------------------|-----|
| Light diffusing film | 8%  |
| Gray filter          | 31% |
| Green filter         | 61% |
- b. Ranking
- |                      |     |
|----------------------|-----|
| Light diffusion film | 3.3 |
| Gray filter          | 3.4 |
| Green filter         | 3.6 |
10. Evaluation of general printer illumination
- a. Preferred method
- |                      |     |
|----------------------|-----|
| without added baffle | 9%  |
| Gray baffle          | 36% |
| Green baffle         | 55% |
- b. Ranking
- |                      |     |
|----------------------|-----|
| without added baffle | 3.1 |
| Gray baffle          | 3.6 |
| Green baffle         | 3.7 |
11. Evaluation of modifications to supervisor's desk
- a. Ranking of three sided shield 3.7
- b. Rating of preferred desk lamp by supervisors
- |                      |     |
|----------------------|-----|
| A. Electrix Classic  | 5%  |
| B. Electrix Petite   | 5%  |
| C. Luxo Crownlight   | 16% |
| D. Tensor Model 6500 | 74% |
- c. Rating of preferred desk lamp by controllers
- |                      |     |
|----------------------|-----|
| A. Electrix Classic  | 14% |
| B. Electrix Petite   | 7%  |
| C. Luxo Crownlight   | 0%  |
| D. Tensor Model 6500 | 79% |
12. Evaluation of PVD Indicators
- a. Preferred indicators
- |                                  |     |
|----------------------------------|-----|
| black letter on white background | 19% |
| white letter on black background | 81% |
- b. Ranking of visual comfort
- |                                  |     |
|----------------------------------|-----|
| black letter on white background | 2.9 |
| white letter on black background | 4.1 |
- c. Ranking of legibility
- |                                  |     |
|----------------------------------|-----|
| black letter on white background | 3.5 |
| white letter on black background | 4.2 |

13. Importance of balancing plenum lights
  - a. Ranking of importance 3.9
14. Omitted. (Nylon mesh material)
15. Summary of general reaction to lighting changes
  - Glare on PVD reduced
  - Reflections reduced
  - Light control film on map boards is good
  - PVD glare still exists
  - High contrast between bright flight strips and dark PVD still exists
16. Suggestions for other lighting improvements
  - Controllable background on PVD
  - Change slope of PVD
  - Turn on overhead direct lights
17. Evaluation of testing methods
  - Changes not always known
  - Need more tests and improvements
  - More eye strain with a dark control room
  - Prefer a well-lighted environment

## 7.0 DISCUSSIONS OF RESULTS

The results obtained from the photometric measurements and the controller subjective evaluations are substantially the same. There is general agreement that the study has identified the principal sources of reflection and glare and that the modifications have, in fact, reduced the detrimental effects of the sources. According to the subjective evaluation, the areas still requiring additional study are: 1) general aisle lighting, 2) flight strip illumination and 3) the general working areas of the A and D controller. The third area could be considered one component of the flight strip illumination problem. There is also agreement between the conclusions of the study and the controllers that the overall illumination of the ARTCC should be increased. Each of the specific areas of improvement are discussed in the following paragraphs.

### 7.1 Ambient Illumination

The results of both the photometric measurement and the controller evaluation segments of the study indicate that the present ambient illumination level in the ARTCC is too low and that a balancing of the indirect plenum lights is desirable. Increasing the plenum illumination to 1.3 ft-L (as measured off of the ceiling), in conjunction with the light directed into the aisle by the light control film over the map boards, would provide an adequate 0.75 ft-c of illumination in the aisle. Such an increase in the plenum illumination level would provide a 47% increase in the wall/ceiling reflections on the PVD, which still seems to be well within the tolerance limits of the controller. This is shown in Figure 7.1. Although the controllers showed a preference for the under-desk lights, they found that they were too bright and consequently a dis-



FIGURE 7.1 - BALANCED AMBIENT ILLUMINATION WITH MAP BOARD LIGHTS  
DIRECTED TOWARD THE AISLE

traction in the present installation. In addition, the under-desk lights provided no more illumination to the center of the aisle than the map boards modified with light control film under identical ambient illumination conditions.

The principal problem with the ambient illumination of the ARTCC is best seen in the answers to questions 4-5. Under the present conditions, two distinct levels of illumination are required simultaneously in approximately the same area: The R-man requires a low light level ( $<0.5$  ft-L) to operate the PVD while the A and D controllers and the supervisor require higher intensity (5.0 ft-L) in order to perform their respective tasks. This problem is easily solved for the supervisor's position by placing a baffle around three sides of the desk and by employing a desk lamp with a shade long enough to prevent direct glare from the bulb from reaching the controller as shown in Figure 7.2. The more difficult problem of providing adequate illumination to the A and D controllers and, at the same time minimizing illumination to the R-controller at the adjacent position, is further compounded by the fact that the R-controller must also view the flight strips. Since any contrast ratio between the flight strips and the PVD greater than 7:1 (Adler 1953) will result in eye fatigue, and the minimum contrast required is in the order of 10:1, either a compromise in the requirements must be made or a new technique for presenting flight strip information found. Since the use of a CRT to present flight strip data is beyond the scope of the modifications employed in this study, a compromise in the intensity of the flight strip illumination is suggested in Paragraph 7.3.



FIGURE 7.2 - BAFFLE AND LAMP ON SUPERVISORS DESK

## 7.2 Map Boards

The results of the photometric measurements and the controller evaluations were in agreement that the light control film over the map board does eliminate the map board reflections on the PVD. The readability of the map board with light control film at the controller position is seen in Figure 7.3. For the most part the controllers did not like the timer modification because it required an extra operation to turn it on, the light would go off before they could find the information they wanted, and the intermittent reflection on the opposing PVD was more distracting than the steady-state reflection. The photo-negative or "black" map was also rejected by the controllers since the reflection was still seen in the opposing PVD, as shown in Figure 7.4.

## 7.3 Flight Strip

The most difficult problem to resolve is that of satisfactorily lighting the flight strips. The mechanical louvers located above the flight strips do not adequately deflect stray light from the PVD, as shown in Figure 7.5, and the radar controller has two major complaints: 1) the light on the face of the PVD is distracting and, 2) he is forced to visually accommodate his eyes as he scans back and forth between the PVD and the flight strips. The minimum of 20:1 difference in contrast causes eye fatigue. Thus, there are two conflicting problems: 1) reducing the illumination or spill of light onto the PVD; and 2) providing adequate light on the flight strips, complicated by the fact that when the flight strips are adequately illuminated, the resulting glare on the PVD on the opposite side of the room is unacceptable.

Utilization of the louvers and the light control film causes an immediate 50% reduction in the overall illumination of the flight strip area. In

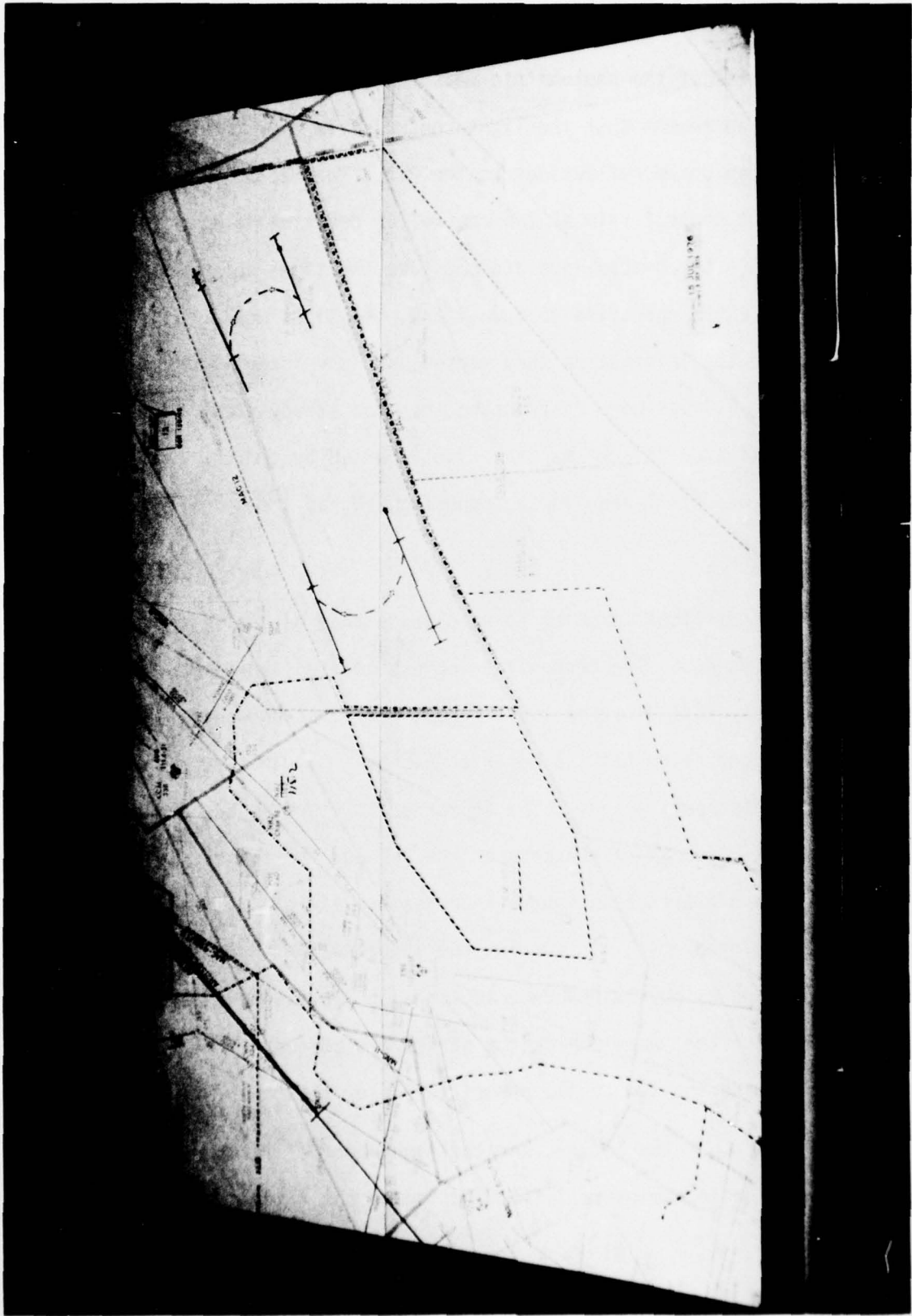

FIGURE 7.3 - VIEW OF MAP BOARD WITH LIGHT CONTROL FILM FROM  
RADAR CONTROLLER'S POSITION



FIGURE 7.4 - REFLECTION OF "BLACK" MAP ON PVD



FIGURE 7.5 - FLIGHT STRIP ILLUMINATION WITH LOUVERS ONLY

addition, the fluorescent lamp has a 2:1 ratio in illumination intensity from the center to the edge, thereby causing the area closest to the PVD, which is of prime concern, to have the least amount of illumination. When stray light from the flight strips is cancelled on the PVD by the light control film, the "A" controllers complain that illumination with the louvers and light control film is too low for them to adequately read the flight strip. In order to increase the intensity of the flight strip illumination, the last 12 inches of light control film under the louver farthest from the PVD was removed. The 24 inches of light control film remaining under the louver succeeded in cancelling the stray light on the PVD as shown in Figure 7.6. At the same time, the overall intensity of illumination on the flight strips was increased to 2.6 ft-L at the lower area closest to the PVD. After the evaluation was completed, the Luxor Vita-Lite fluorescent bulbs were substituted for the Cool White bulbs. Although it was not possible to make photometric measurements at that time, the new bulbs did remove the yellow component from the illumination, and the brightness and contrast of the first row of flight strips seemed to have been increased. Both the 1/2 inch louver alone and no louver caused unacceptable amounts of stray light to appear on the surface of the PVD. If further evaluation is to take place, it is suggested that photometric measurements be taken of the light control film/louver/Vita-Lite combination and that a 1-inch mechanical louver with a 30° angle away from the PVD also be evaluated.

#### 7.4 PVD Console

The results of both the photometric measurements and the subjective evaluation by the controller showed that the photo-negative legends on the PVD console were superior to the standard legends in terms of both glare reduction and legibility.

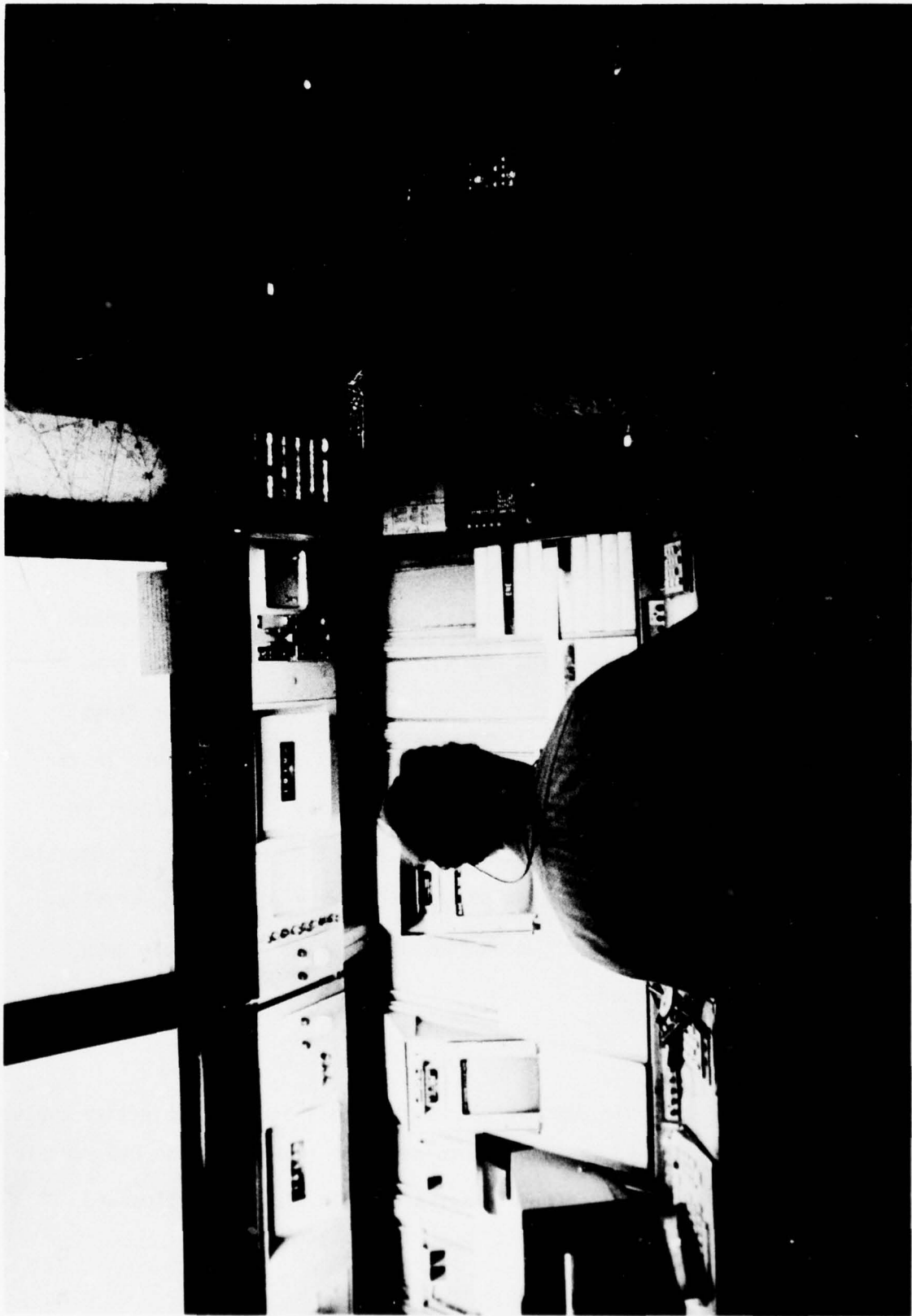

FIGURE 7.6 - FLIGHT STRIP ILLUMINATION WITH LOUVERS AND 24"  
OF LIGHT CONTROL FILM

At the same time, the controllers and their supervisors suggested changes to the legends as shown in Figure 7.7 in order to increase legibility.

After the lighting study evaluation was completed, a PVD with variable CRT background brightness was demonstrated at the Boston ARTCC. A cursory evaluation led to the following conclusions:

1. Increasing the background brightness tends to obscure the reflections in the PVD; however, the controller would then be required to make a choice between a potential loss of acuity in low target-to-background situations or the blurring of PVD reflections.
2. There is less difference in the brightness contrast between the PVD and the flight strips within the maximum allowable 7:1 limits.
3. As presently demonstrated, the design is inadequate since the brightening lines are highly visible and the display is truncated at the edges.
4. Brightening requires approximately 3 milliseconds of the available 18 milliseconds available for data. If the data rate is high, the brightening will be inhibited.
5. Implementation requires three new printed circuit boards, changes to the main wiring, a new focus module in each PVD, and appears to be a costly modification with a minimal positive effect upon the PVD reflection problem.

TRNG	OTMP
------	------

P SET	MANL
-------	------

C POW	CDCP		C FAL
-------	------	--	-------

SROB	SROB	SROB	SROB
------	------	------	------

RDR 1	RDR 2	RDR 3	RDR 4
----------	----------	----------	----------

WX 1	WX 2	STRB	
------	------	------	--

MAP 1	MAP 2	MAP 3	MAP 4
-------	-------	-------	-------

INLT	DPLT	HOLT	
------	------	------	--

FUDB	ALDB	SLDB	
------	------	------	--

APRM	NMCB	SBCN	
------	------	------	--

00 52	53 72	73 102	103 142
----------	----------	-----------	------------

143 175	176 255	256 340	341 999
------------	------------	------------	------------

AID	AALT	RALT	CID
-----	------	------	-----

ESBD		LEAD	PSYM
------	--	------	------

FIGURE 7.7 - SUGGESTED LEGENDS FOR PVD INDICATORS

DSIM	RSB			

NONE	AHAN	CANC	REDO	REPT
CO	HOLD	CRD	QIKL	
TRAC	RUTE	PVD	T ALT	CODE

#### 7.5 Printer Illumination

Both the photometric measurements and the controller evaluations showed that the green filter was best in eliminating the glare from the printer. Similar results were obtained for elimination of the glare from the printer indicators. One of the problems in obtaining a true evaluation of the indicators was the fact that during the evaluation period some printers were removed from the area for repair, and the controller found it difficult to distinguish which printers had the gray filter and which had the light diffusing film. Since the principal desire is simply the dimming of the indicator to remove the glare source, it would be more economical to use 2 layers of the 3M self adhesive light diffusing material rather than have to go through the expense of designing and installing plastic filters in the indicators. This should be tested if further investigations are to take place.

#### 7.6 General Reactions of the Controllers to the Modifications

The results of the subjective evaluation showed that the controllers believe that the specular reflections on the PVD and glare sources have been reduced by the modifications. They feel that the light control film over the map boards solves the specular reflection on the PVD. However, the problem of the contrast between the flight strips and the PVD as stated in Paragraph 7.3 still exists.

#### 7.7 Controller Suggestions for Other Lighting Improvements

In reading the 31 questionnaires, three potential improvements were suggested. Each is listed below with the author's comments:

1. Provide a Controllable Background on the PVD

This was attempted after the evaluation was completed by providing a PVD with digital brightening. The brightening suc-

ceeded in dulling the specular reflections; however, as implemented, digital brightening had several drawbacks: 1) The 100 brightening lines were readily apparent on the face of the PVD and the four sides of the display were truncated. 2) In order to provide brightening, 3 of the 18 milliseconds available for data must be utilized; therefore, if the data rate is high, brightening is not provided. 3) Implementation of the design will be costly, requiring three new printed circuit boards, changes to the baseplate wiring, and a new focus module.

## 2. Change the Slope of the PVD

It was suggested that the slope of the PVD be changed from the present  $68^\circ$  from the horizontal to the same  $45^\circ$  of the flight strip M-1 Console. On the surface, this appeared to be a good idea in that at  $45^\circ$  the PVD would be shielded from specular reflection by the underside of the canopy. Upon closer investigation, it was found that the construction of the plenum housing and air cooling ducts were such that in order to place the PVD in the  $45^\circ$  position the console would have to be moved forward approximately 12 inches. When the PVD console is moved forward by this amount, the canopy no longer acts as a reflection shield and map board and ceiling or wall reflections are again present.

### 3. Turn On Overhead Direct Lights

It was suggested that the overhead direct lights be turned on and a baffle be placed in front of them to prevent the direct reflection of the illuminated fixtures. Since there is no provision to control the intensity of the overhead lights, the increased illumination would cause the face of the PVD to act as a mirror, intensifying all reflections.

### 7.8 Controller Evaluation of Testing Methods

By summarizing the comments of the controllers and supervisors, it was found that the evaluation attempted to provide too many different types of modifications in each of the defined problem areas at one time. Therefore, the controllers often found it difficult to keep track of them and, at times, to differentiate one change from another. This was especially true in the printer area, where the printers in the test area were removed for repair and the new printers were not modified.

The general consensus of opinion of the controllers seems to be that they would like to have more illumination in the ARTCC with greater glare and reflection reduction, therefore, more tests appear to be required.

## 8.0 REFERENCES

Adler, H. E., et. al., Masking of Cathode Ray Tube Displays by Ambient Illumination, Wright Air Development Center, WADC Technical Report 53-266, AD 30677, November 1953.

Colman, K. W., Courtney, D., Freeman, J. B., and Bernstein, R., The Control of Specular Reflections from Bright Tube Radar Displays, Courtney and Co., Technical Report 23, Philadelphia, Pa., November 15, 1958.

Hampton, D. B. and Carr, R. M. Evaluation of Anti-Glare Coatings for Use in the BQS-13 Sonar System, Raytheon Company: Contract NObsr 93178, Task C, February 20, 1967.

Parsons, R. A. and Co. Expansion and Modernization of Air Route Traffic Control Centers, Volume V, Control Room Lighting Tests. Department of Transportation, Federal Aviation Administration, Washington, D. C., July 27, 1970.

Spanier, G., et. al. Anti-Reflective Glass (patent application). Department of Transportation Report No. DOT/Case A-00177, PAT-APPL-241 840, filed April 6, 1972.

AD-A041 324

RAYTHEON CO SUDBURY MASS EQUIPMENT DIV  
BOSTON AIR ROUTE TRAFFIC CONTROL CENTER (ARTCC)  
MAY 77 C M HALL, R M CARR, A J KOPALA

F/G 17/7  
LIGHTING STUDY.(U)  
DOT-FA76WA-3738

UNCLASSIFIED

FAA-RD-76-203

NL

2 of 2  
ADA041324



END

DATE  
FILMED  
8 - 77

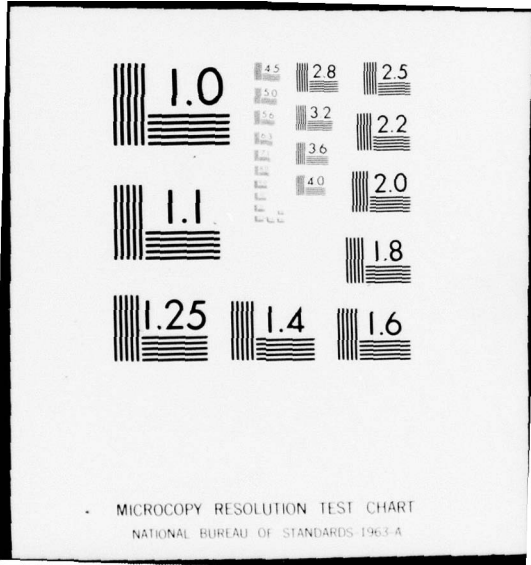

MICROCOPY RESOLUTION TEST CHART  
NATIONAL BUREAU OF STANDARDS-1963-A

APPENDIX A

PHOTOMETRIC MEASUREMENTS

PHASE TWO PHOTOMETRIC MEASUREMENTS

TABLE A-1

AMBIENT ILLUMINATION

<u>MEASURE*</u>	<u>POSITION</u>	<u>PHASE ONE READING</u>	<u>PHASE TWO READING</u>
1.	Ambient Illumination 1' From Floor (Control)	0.13 ft-c	0.13
2.	Under-Desk Light at Maximum Intensity 1' From Floor	1.50 ft-c	-
3.	Light Control Film (LCF) on Map Board	0.75 ft-c	0.75
4.	Under-Desk Lights (Taped) plus LCF on Map Board	0.75 ft-c	-
5.	Ambient Lights plus LCF on Map Boards 1' From Floor	0.75 ft-c	0.75
6.	Ambient Lights with Map Boards Off	0.32 ft-c	0.32
7.	Ambient Illumination 5' From Floor (Control)	0.26 ft-c	0.26
8.	Ambient plus Maximum Intensity Under-Desk Lights	0.50 ft-c	-
9.	Ambient plus LCF on Map Boards	0.50 ft-c	0.50
10.	Ambient Lights Balanced for Maximum Intensity	1.3 ft-L	1.6
11.	Maximum Intensity of Under-Desk Lights 6" From Floor	97.0 ft-c	-
12.	Under-Desk Lights Dimmed with Black Tape	16.0 ft-c	-
13.	Aluminum Bezel on Speaker	89.0 ft-L	-

\* Refer to Figure 5.4 in the text for illustration of measurement points.

TABLE A-2  
MAP BOARD

MEASURE*	POSITION	CONTROL		ACROSS	
		Phase One	Phase Two	Phase One	Phase Two
1.	Upper Left	16.0	18.0	4.7	9.0
2.	Upper Center	20.0	20.0	7.4	11.0
3.	Upper Right	39.0	18.0	5.1	13.0
4.	Upper/Center Left	42.0	22.0	11.0	18.0
5.	Upper/Center Center	38.0	34.0	14.0	21.0
6.	Upper/Center Right	16.0	28.0	10.2	23.0
7.	Center Left	22.0	41.0	22.0	24.0
8.	Center Center	36.0	55.0	30.0	39.0
9.	Center Right	47.0	48.0	16.0	28.0
10.	Lower/Center Left	37.0	45.0	34.0	31.0
11.	Lower/Center Center	18.0	68.0	45.0	44.0
12.	Lower/Center Right	18.0	67.0	20.0	30.0
13.	Lower Left	33.0	37.0	15.0	16.0
14.	Lower Center	39.0	67.0	18.0	19.0
15.	Lower Right	37.0	56.0	12.0	15.0
	Mean Brightness	30.5	41.6	17.6	22.7
				0.4	0.4

\* Refer to Figure 5.5 in the text for illustration of measurement points.

TABLE A-3

FLIGHT STRIP

<u>MEASURE **</u>	<u>POSITION</u>	<u>Phase One</u>			<u>Phase Two</u>
		No Louvers	Louvers	Louvers Light Control Film	Extended Louvers and Plastic Guard
		<u>Ft-L</u>	<u>Ft-L</u>	<u>Ft-L</u>	<u>Ft-L</u>
1.	Top Right PVD	1.6	0.2	0.2	0.2
2.	Center Right PVD	3.3	0.6	0.3	0.3
3.	Bottom Right PVD	2.3	0.3	0.2	0.2
4.	Top Right Console	18.0	4.3	0.5	0.2
5.	Center Right Console	5.9	1.5	0.2	0.4
6.	Bottom Right Console	4.8	1.2	0.2	0.5
7.	Top Left Flight Strip	44.0	26.0	2.2	13.5
8.	Top Center Flight Strip	64.0	40.0	5.1	20.0
9.	Top Right Flight Strip	23.0	11.0	2.6	7.5
10.	Center Left Flight Strip	41.0	23.0	2.0	9.5
11.	Center Flight Strip	63.0	36.0	5.1	16.5
12.	Center Right Flight Strip	7.4*	4.0*	1.3*	2.5
13.	Bottom Left Flight Strip	23.0	8.0	1.1	5.0
14.	Bottom Center Flight Strip	26.0	14.0	2.0	9.5
15.	Bottom Right Flight Strip	<u>23.0</u>	<u>10.0</u>	<u>3.0</u>	<u>9.5</u>
	Mean On PVD	6.1	1.4	.27	.30
	Mean on Flight Strip	34.9	19.1	2.7	10.4

\*CRD Display

\*\* Refer to Figure 5.6 in the text for illustration of measurement points.

TABLE A-4

PUSHBUTTONSPhase One Measurements

<u>MEASURE *</u>	<u>POSITION</u>	<u>POSITIVE CAPS</u> <u>Ft-L</u>	<u>NEGATIVE CAPS</u> <u>Ft-L</u>
1.	INBND List	34.0	0.2
2.	MAP 3	16.0	0.1
3.	ASGNED ALT	59.0	0.2
4.	CO	0.4	0.2
5.	QUICK LOOK	<u>0.6</u>	<u>0.2</u>
	Mean Brightness	11.2	0.2

Phase Two Measurements

<u>MEASURE*</u>	<u>POSITION</u>	<u>DEPRESSED</u>	<u>NEGATIVE CAPS</u> <u>NOT DEPRESSED</u>
1.	INBND	3.0	0.2
2.	MAP 3	13.0	0.2
3.	ASGNED ALT	4.0	0.2
4.	CO	2.6	0.3
5.	QUICK LOOK	<u>4.5</u>	<u>0.2</u>
	Mean Brightness	5.4	0.2

\* Refer to Figure 5.7 in the text for illustration of measurement points.

TABLE A-5  
REFLECTIONS ON PVD

<u>MEASURE</u>	<u>REFLECTION DESCRIPTION</u>	<u>Phase One Reading</u>	<u>Phase Two Reading</u>
		<u>Ft-L</u>	<u>Ft-L</u>
1.	No reflection on PVD	0.17	0.05
2.	Positive Map Board (Control	0.64	1.10
3.	Positive Map Board (Light Control Film)	0.18	0.11
4.	Flight Strip (No Louvers or L.C. Film)	1.60	-
5.	Flight Strip (Louvers and L.C. Film)	0.42	-
6.	White Paper 18" from PVD	0.24	0.15
7.	Operator at PVD	0.20	0.12
8.	Ceiling	0.25	0.14
9.	Speaker bezel (no louvers or L.C. Film)	2.10	-
10.	Speaker bezel (louvers and L.C. Film)	1.40	-
11.	Flight strip extended louvers	-	0.45

TABLE A-6

PRINTER

Phase One Measurements

<u>MEASURE**</u>	<u>POSITION</u>	<u>No Filter Ft-L</u>	<u>Green Filter Ft-L</u>	<u>Gray Filter Ft-L</u>	<u>Light Control Film 3 Layers Ft-L</u>	<u>Light Control Film 2 Layers Ft-L</u>
1.	At Paper	79.0	8.1	23.0		
2.	Ready Light	70.0	9.0	23.0	20.0	25.0
3.	First Line Light	41.0	10.0	20.0	18.0	22.0

Phase Two Measurements

<u>MEASURE**</u>		<u>Green Filter Ft-L</u>	<u>Light Diffusing (8 mils) Ft-L</u>
1.	At Paper	10.5	-
2.	Ready Light	-	24.0
3.	First Line Light	-	*

\*Light diffusing material was not inserted behind Key Cap.

\*\*Refer to Figure 5.8 in the text for illustration of measurement points.

APPENDIX B  
QUESTIONNAIRE FOR  
EVALUATION OF CONTROL ROOM LIGHTING IMPROVEMENTS

APPENDIX B

QUESTIONNAIRE

CONTROL ROOM LIGHTING IMPROVEMENTS

INSTRUCTIONS

This questionnaire is intended primarily for qualified radar and manual controllers who have worked at the Boston ARTCC for at least one year. Please read and answer the questionnaire after making a thorough examination of the lighting changes in Area D and after sitting in the several control positions in this area and in another area with conventional lighting. If feasible, fill in your answers while still in the control room so that you may look back and see the several positions referred to in the questions.

Years experience at this Center \_\_\_\_\_

DATE \_\_\_\_\_ Usual AREA assignment \_\_\_\_\_

ATC Qualification: RADAR \_\_\_\_\_, MANUAL \_\_\_\_\_, ASST \_\_\_\_\_

If a supervisor, check here \_\_\_\_\_

## INTRODUCTION

The goal in control room lighting improvement is to enhance the comfort and seeing efficiency of all personnel. Three factors can reduce seeing comfort and effectiveness: glare, stray light, and reflections.

Glare results from light sources that are too bright and are in your field of view because they are near things you need to look at. If forced to look toward bright light sources while working with dim displays, the pupil of your eye must contract. This makes for fatigue, and it makes it harder to see dim targets and characters.

Stray light is light that falls on things that need not be illuminated, for example the controller's white shirt. Surfaces lighted by stray light may in turn become sources of reflections.

Reflections are unwanted images resulting from miscellaneous light sources and appearing on the surface of the PVD and other glass or polished surfaces. Since reflections are distracting and make it harder to see the important information, the main aim of the present lighting improvements is to control glare and stray light so as to lessen the sources of reflections.

## PRESENT IMPROVEMENTS

The changes that you are evaluating have been designed to lower the sources of general room lighting (to reduce stray light), also to reduce the intensity of glare sources (such as the printer lamps), and to further reduce annoying reflections by screening flight strip lights and map board lights to cut out scattered light.

## NEXT STEPS

Please answer the following questions to indicate the degree to which you approve of the lighting changes and to give advice on any added improvements that you can recommend. Based on your answers and the results of light level measurements that are being made, changes in control room lighting may be recommended for national implementation.

1. Check (X) aspects of control room lighting that you think have needed improvement before the current changes to make the job of the radar controller more comfortable and efficient.

	Have Been Satisfactory	Needed Improvement
a. Reflections in PVD	_____	_____
b. Glare Sources (such as printer lamps)	_____	_____
c. Stray light (as from flight strips)	_____	_____
d. Overall aisle lighting	_____	_____

2. Indicate whether you feel that the changes in the test area have brought about worthwhile improvement.

	Have Been Improved	No Significant Improvement
a. Reflections in PVD	_____	_____
b. Glare Sources	_____	_____
c. Stray light	_____	_____
d. Overall Aisle lighting	_____	_____

3. Rate your general satisfaction with the lighting as modified in the test area. Enter an X in the column appropriate for each item.

	Suitable	Unsuitable
a. General aisle light	_____	_____
b. Flight Strip illumination	_____	_____
c. Map board lighting (consider the version you prefer as best)	_____	_____
d. PVD Keys and CUE	_____	_____
e. Flight Strip Printer (best alternative)	_____	_____
f. Shelf area of PVD	_____	_____
g. General working area for D man	_____	_____
h. General working area for A man	_____	_____

4. Recognizing that the brighter the general control room lighting, the more reflections will be produced, how important is it to have a high level of room light ? (check one)

a. General room light should be lower than usual \_\_\_\_\_

b. General room light should be about where it usually is \_\_\_\_\_

c. General room light should be increased \_\_\_\_\_

5. Do you think that different control room jobs can be better performed under particular light levels ? (Note your agreement or difference with each of the following statements.)

	Agree	Disagree
a. Radar controllers need a dimly lighted control room	_____	_____
b. Manual controllers need a low light level also	_____	_____
c. Assistant controllers prefer more light	_____	_____
d. Floor supervisors prefer more light than R-men	_____	_____
e. Managers prefer a control room with more light	_____	_____

6. Since the under the counter "knee lights" allow turning off or reducing the light on control room walls, do you find using them reduces reflections ?

a. With knee lights and less wall light, reflections are down Agree    Disagree  
\_\_\_\_\_

7. Map Board lighting has been modified three different ways. Which do you prefer and how do you evaluate each method?

a. The method that improves the visual situation at the PVD the most is:

The timing switch \_\_\_\_\_ Light control film \_\_\_\_\_ Black maps \_\_\_\_\_

b. Using the timing switch map-board lighting is: Excellent \_\_\_ Good \_\_\_ Fair \_\_\_ Poor \_\_\_ Bad \_\_\_

Using the light control film map-board ltg is Excellent \_\_\_ Good \_\_\_ Fair \_\_\_ Poor \_\_\_ Bad \_\_\_

Using black maps Map-board Lighting is Excellent \_\_\_ Good \_\_\_ Fair \_\_\_ Poor \_\_\_ Bad \_\_\_

8. Flight strip bay lights have been demonstrated with louvers added to reduce the spread of light, with added light control plastic material inserted under the louvers, and with no louvers. Please indicate your choice of the best of these lights and rate each one.

a. The method of lighting flight strips that is best in my opinion is:

No louvers \_\_\_\_\_ With louvers \_\_\_\_\_ With louvers over the plastic \_\_\_\_\_

b. With no louvers, flight strip lighting is:            Excellent \_\_\_\_\_ Good \_\_\_\_\_ Fair \_\_\_\_\_ Poor \_\_\_\_\_ Bad \_\_\_\_\_

With added louvers, flight strip lighting is:            Excellent \_\_\_\_\_ Good \_\_\_\_\_ Fair \_\_\_\_\_ Poor \_\_\_\_\_ Bad \_\_\_\_\_

With louvers over the plastic, flight strip lighting is:            Excellent \_\_\_\_\_ Good \_\_\_\_\_ Fair \_\_\_\_\_ Poor \_\_\_\_\_ Bad \_\_\_\_\_

9. Printer lamps have been screened with light control plastic material and also with gray plastic and with green plastic. Please indicate your choice as to the best of these methods of reducing excess light and rate each one.

a. The best method of reducing printer lamp intensity is:

Light control material \_\_\_\_\_ Gray filter \_\_\_\_\_ Green filter \_\_\_\_\_

b. Using the light control material, lamp intensity reduction is:            Excellent \_\_\_\_\_ Good \_\_\_\_\_ Fair \_\_\_\_\_ Poor \_\_\_\_\_ Bad \_\_\_\_\_

Using gray filter, lamp intensity control is:            Excellent \_\_\_\_\_ Good \_\_\_\_\_ Fair \_\_\_\_\_ Poor \_\_\_\_\_ Bad \_\_\_\_\_

Using green filter, lamp intensity control is:            Excellent \_\_\_\_\_ Good \_\_\_\_\_ Fair \_\_\_\_\_ Poor \_\_\_\_\_ Bad \_\_\_\_\_

10. Printer general illumination was demonstrated with a gray and also with a green baffle added to reduce light output. Please indicate your choice of the best method to use and rate each one.

a. The best printer general illumination condition is:

Without an added baffle \_\_\_ Gray baffle \_\_\_ Green baffle \_\_\_

b. Without a baffle, printer general illumination is: Excellent \_\_\_ Good \_\_\_ Fair \_\_\_ Poor \_\_\_ Bad \_\_\_

With an added gray baffle, printer illumination is: Excellent \_\_\_ Good \_\_\_ Fair \_\_\_ Poor \_\_\_ Bad \_\_\_

With an added green baffle, printer illumination is: Excellent \_\_\_ Good \_\_\_ Fair \_\_\_ Poor \_\_\_ Bad \_\_\_

11. Evaluate the changes made at the supervisor's desk as follows:

a. The three-sided desk shield intended to help the floor controllers by blocking off a glare source is:

Excellent \_\_\_ Good \_\_\_ Fair \_\_\_ Poor \_\_\_ Bad \_\_\_

b. Of the several new desk lamps demonstrated, the best from the view of the floor controllers is:

Lamp A \_\_\_ Lamp B \_\_\_ Lamp C \_\_\_ Lamp D \_\_\_ Lamp E \_\_\_ Lamp F \_\_\_

c. As a controller, which of the lamps on the floor supervisor's desk emitted the least stray light at your position:

Lamp A \_\_\_ Lamp B \_\_\_ Lamp C \_\_\_ Lamp D \_\_\_ Lamp E \_\_\_ Lamp F \_\_\_

12. Evaluate the two types of key caps demonstrated at the PVD:

a. The best key cap is: Black letter on white \_\_\_

White letter on black \_\_\_

b. For visual comfort, the black letter on white background caps are:

Excellent \_\_\_ Good \_\_\_ Fair \_\_\_ Poor \_\_\_ Bad \_\_\_

For visual comfort, the white letter on black background caps are:

Excellent \_\_\_ Good \_\_\_ Fair \_\_\_ Poor \_\_\_ Bad \_\_\_

c. For legibility, the black letter on white background caps are:

Excellent \_\_\_ Good \_\_\_ Fair \_\_\_ Poor \_\_\_ Bad \_\_\_

For legibility, the white letter on black background caps are:

Excellent \_\_\_ Good \_\_\_ Fair \_\_\_ Poor \_\_\_ Bad \_\_\_

13. In the test area, the plenum lights have been controlled to provide an improved balance of illumination. Evaluate the importance of keeping these lights balanced:

Essential \_\_\_ Desirable \_\_\_ No difference \_\_\_ A distraction \_\_\_ Bad \_\_\_

14. As one attempt to improve vision at the PVD, a nylon mesh was placed over the CRD. Evaluate the utility of this mesh for the controller:

The nylon mesh is: Essential \_\_\_ Good \_\_\_ Fair \_\_\_ Poor \_\_\_ Bad \_\_\_

15. Summarize in your own words your general reaction to the lighting changes in the test area:

a. The controller's visual situation is better in the test area in these ways \_\_\_\_\_

\_\_\_\_\_  
\_\_\_\_\_

b. The controller's visual situation is worse in the test area in these ways \_\_\_\_\_

\_\_\_\_\_  
\_\_\_\_\_

16. Other or different lighting changes or improvements that should be tested are as follows:

\_\_\_\_\_  
\_\_\_\_\_  
\_\_\_\_\_

17. Please add any comments that you may care to make about the control room lighting test. For example, do you think the test was long enough? Was the method of illustrating the changes adequate? Were too many lighting changes demonstrated all at once, or could you sort out the different effects when answering the questionnaire? etc.

---

---

---

APPENDIX C

LITERATURE REVIEW AND BIBLIOGRAPHY

## TABLE OF CONTENTS

<u>Section</u>		<u>Page</u>
1.0	STATEMENT OF PROBLEM AND BACKGROUND	1
2.0	DEFINITION OF TERMS	4
2.1	Glare	4
2.2	Reflection	5
2.3	Photometric Terminology	6
3.0	LITERATURE	9
3.1	Discussion	9
3.2	Summary	22
4.0	RECOMMENDATIONS FROM THE LITERATURE	24
4.1	Introduction	24
4.2	Control of Reflected Glare	24
4.3	Ambient Lighting Recommendations	30
5.0	SUMMARY OF RECOMMENDATIONS	34
5.1	Circular Polarizers	34
5.2	Wire Mesh Filters	34
5.3	Color/Neutral Filters	34
5.4	Etches	34
5.5	Optical Coating	35
5.6	Etching and Optical Coating	35
5.7	Ambient Lighting	35
	REFERENCES	36

LIST OF FIGURES

<u>Figure</u>		<u>Page</u>
1.1	Location of Reflections on the Face of PVD	2
3.1	First Surface Reflection	9
3.2	First Surface Reflection (Glass)	10
3.3	Multiple Surface Reflections	11
3.4	Specular Brightness of Paper and Ink (Foot Lamberts)	13
3.5	Holladay Curves	20
4.1	Courtney Reflection Attenuator	25
4.2	Lewin "Twin-Beam" System	33
4.3	Photometric Curve for "Twin-Beam" System	33

LIST OF TABLES

<u>Table</u>		<u>Page</u>
2.1	Conversion Factors for Common Luminance Units	7
2.2	List of Terms, Symbols and Conversion Factors for Photometric Units	8

## 1.0 STATEMENT OF PROBLEM AND BACKGROUND

The air traffic controllers at the various Air Route Traffic Control Centers (ARTCC) throughout the United States experience glare and reflection problems while using the Plan View Display (PVD) equipment. The problem is caused by extraneous reflections on the CRT face at the PVD units and other glaring light sources present in the immediate work areas. The reflections and glare provide a questionable working environment which may, at times, lead to controller eyestrain and fatigue.

The purpose of this report is to synopsise the available literature on the subjects of glare and reflection as it pertains to tasks and environments similar to those found at the ARTCC's. A great deal of research has been conducted in this field. Some 150 reports were found dealing with glare and reflection. Unfortunately, of these, only 32 of them applied either directly or indirectly to these glare and reflection problems encountered in the ARTCC. The specific problems to be addressed include specular reflections on the PVD screen, inadequate and/or imbalanced ambient room lighting, and extraneous light from keyboards and printers, causing unnecessary and harsh glare on the eyes of the controller. The majority of the available literature addresses problems faced in determining proper room lighting or glare and reflection problems faced on a printed (or handwritten) page. These investigations deal predominantly with problems of "veiling reflection" rather than the primary problem to be considered here of "specular reflection" and glare.

One of the first problems encountered while conducting the literature search for this project was the ambiguity found in the employment of the terms "glare" and "reflection." Quite often they are considered by the authors to be interchangeable. "Reflected glare" is one of those terms common to many of the articles; many times it is employed as a synonym for "veiling reflection." In this report, the definitions of these terms are taken from the Illuminating Engineering Society (IES) Handbook (1972): "reflected glare" is "glare resulting from specular reflections of high luminances in polished or glossy surfaces in the field of view"; and "veiling reflections" are "regular (specular) reflections superimposed upon diffuse reflections from an object that partially or totally obscure the details to be seen, by reducing the contrast." That is, the term "reflected glare" will be reserved for the disabling effects of specular reflections on glassy surfaces (the PVD face) and "veiling reflection" will refer to losses of contrast between task and background caused by diffuse and specular reflections (on, for example, a newspaper page).

The actual PVD reflection problem as perceived by the Radar Controller is shown in Figure 1.1 below. There are four separate sources of specular reflections: (1) the overhead canopy, (2) the wall and ceiling (3) the mapboards and (4) the M1 console and flight strips of both the position in question and its opposite across the room.

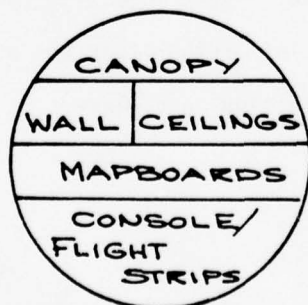

FIGURE 1.1  
LOCATION OF REFLECTIONS ON THE FACE  
OF THE PVD - 2 -

In addition to the specular reflection problem, "hotspots" are also present from the mapboards, flight strips and printer. These high sources of ambient light not only cause reflections in opposite PVD faces, but also may cause discomfort due to the high brightness of the reflection area as compared to that of the area immediately surrounding the PVD screen. In addition, there is a spillover of light from the flight strip area onto the PVD face, providing yet another source of specular reflection.

## 2.0 DEFINITION OF TERMS: GLARE AND REFLECTION

### 2.1 Glare

Glare can be defined in general terms as luminance within one's visual field which appears to the eye as excessively brighter than that to which the eye has become adapted, thereby causing annoyance, discomfort, or disability. There are different types of glare classifications; for example, discomfort glare, disability glare, direct glare, or blinding glare.

The term "discomfort glare" is applicable in situations where the viewer does not consciously notice any interference with the performance of his task, but definite signs of eye strain and fatigue are observable. That is, the task/background ratio might be poor enough to cause eyestrain but not so bad as to noticeably affect performance. Discomfort glare is often the result of a phenomenon known as "veiling brightness" -- a condition where the contrast ratio of background (surround) brightness to the task brightness is excessively low.

"Disability glare", on the other hand, occurs wherever the contrast ratio between the background and the task becomes so low as to actually and noticeably interfere with the viewer's ability to see the task. In this case, the glare caused by the light "spilling over" from the flight strip area acts as a disabling glare source because it brightens the surrounding area to such an extent that the PVD screen images become more difficult to see.

This report is concerned with those glare sources which cause discomfort and/or disability with regard to particular work tasks of the controller. Of

particular concern to us are those sources of light that cause a "veiling" effect on the task; that is, those sources which cause a low task/background ratio to occur.

## 2.2 Reflection

Basically there are two main categories into which to separate reflection: "specular" and "diffuse." Specular reflection is also called "regular" reflection by some authors. The IES Handbook defines it as "the process by which incident flux is redirected at the specular angle" (the angle between the normal to the surface and the reflected ray). That is, the angle of incidence is the same as the angle of reflection.

Diffuse reflection on the other hand is defined as "the process by which the incident flux is redirected over a range of angles." That is, the incident light ray(s) is scattered by the reflecting surface in a multitude of directions.

Specular reflection causes mirror images of the original object while diffuse reflection produces shapes and outline, providing a generalized form but not a replica of the original. With the specular phenomenon it is possible to predict the path of the reflected light rays, but because of the dispersing nature of the diffusion phenomenon, prediction of the reflected rays' path is a difficult, if not an impossible, matter. Therefore, avoiding specular reflections becomes a theoretically easy task, since conceivably all one must do is move one's line of sight out of the specular angle. However, avoiding diffuse reflections is not possible in this way.

In most real-life situations perfect cases of either of the two reflection cases does not occur. "Veiling" reflection results when specular reflections are superimposed upon diffuse reflections, thereby causing task/background contrast losses. For the purposes of this study, the PVD face (and any other highly reflecting material) will be considered as a perfectly smooth surface causing "perfect" specular reflection. That is, the study will be concerned primarily with specular reflection problems and the resulting reflected glare problems and with any direct potential disability and discomfort glare found in the controllers' environment.

### 2.3 Photometric Terminology

Various luminance (brightness) units regularly appear in the literature in this field. Table 2.1, taken from Baker and Grether (1963) provides the most common luminance conversion factors. Table 2.2 extracted from the IES Handbook (1972) provides a complete table of conversion factors for all photometric measurements.

Units	Foot-Lamberts	Lamberts	Milli-Lamberts	Candles per square inch (inch-candles)	Candles per square foot (foot-candles)	Candles per square centimeter (centimeter-candles)
ft-L	--	0.001076	1.076	0.00221	0.3183	0.0003426
L	929	--	1,000	2.054	295.7	0.3183
mL	0.929	0.001	--	0.002054	0.2957	0.0003183
c/in <sup>2</sup> (in.-c)	452.4	0.4869	486.9	--	144	0.155
c/ft <sup>2</sup> (ft-c)	3.142	0.00338	3.38	0.006944	--	0.001076
c/cm <sup>2</sup> (cm-c)	2,919	3.142	3,142	6.452	929	

Table 2.1 Conversion Factors for Common Luminance Units

Quantity	Symbol	Defining Equation	Unit	Symbolic Abbreviation
Luminous energy (quantity of light)	Q	$Q_v = \int_{380}^{780} K(\lambda) Q_{e\lambda} d\lambda$	lumen hour lumen-second (talbot)	lm-h lm-s
Luminous density	w	$w = dQ/dV$	lumen-hour per cubic centimeter	lm-h/em <sup>3</sup>
Luminous flux	$\phi$	$\phi = dQ/dt$	lumen	lm
Luminous flux density at a surface Luminous exitance (Luminous emittance) Illumination (Illuminance)	M E	M = $d\phi/dA$ E = $d\phi/dA$	lumen per square foot footcandle (lumen per square foot) lux (lm/m <sup>2</sup> ) phot (lm/em <sup>2</sup> )	lm/ft <sup>2</sup> fc lx ph
Luminous intensity (candlepower)	I	$I = d\phi/d\omega$ ( $\omega$ =solid angle through which flux from point source is radiated)	candela (lumen per steradian)	cd
Luminance (photometric brightness)	L	$L = d^2\phi/d\omega dA \cos\theta$ = $dI/(dA \cos\theta)$ ( $\theta$ =angle between line of sight and normal to surface considered)	candela per unit area stilb (cd/cm <sup>2</sup> ) nit (cd/m <sup>2</sup> ) footlambert (cd/πft <sup>2</sup> ) lambert (cd/πcm <sup>2</sup> ) apostilb (cd/πm <sup>2</sup> )	cd/in <sup>2</sup> , etc. sb nt fL L asb
Luminous efficacy	K	$K = \phi_v/\phi_e$	lumen per watt	lm/W
Luminous efficiency	V	$V = K/K_{\max}$ ( $K_{\max}$ =maximum value of $K(\lambda)$ function)	one (numeric)	

Table 2.2 List of Terms, Symbols and Conversion Factors for Photometric Units

### 3.0 LITERATURE

#### 3.1 Discussion

Whenever a relatively bright luminant source or its reflected image appears in the visual field of an observer, glare is produced, and as a result this glare induces visual distraction, discomfort, decreased visibility, and decreased target-detection ability. One of the prime reasons for this reduced ability of target detection is the psychological phenomenon of the operator tending to focus on the first clearly defined object in his visual field. Because glare tends to obscure visual information, and since reflection of either the bright ambient source or the well-illuminated operator himself becomes the operator's primary focal point of attention on the CRT screen, the operator of the unit is distracted from his primary task.

When a light ray strikes a plane surface such as a highly polished metal, that ray of light is reflected at the same angle at which it hit. That is, in Figure 3.1 we have a ray of light AB hitting a surface at an angle  $\theta$  to the normal (n) to the surface. The ray BC is reflected from the surface at an angle  $\chi$ . By the law of specular reflection,  $\theta = \chi$ .

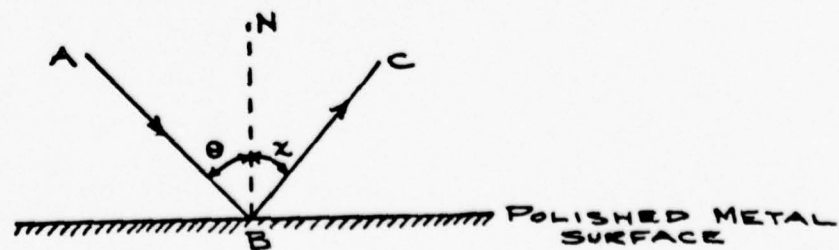

FIGURE 3.1 FIRST SURFACE REFLECTION

The problem is made slightly more complex by the fact that the reflecting medium is glass and not metal. Some of the incident light rays striking a glass surface are transmitted through the glass as well as reflected from its surface (see Fig. 3.2.).

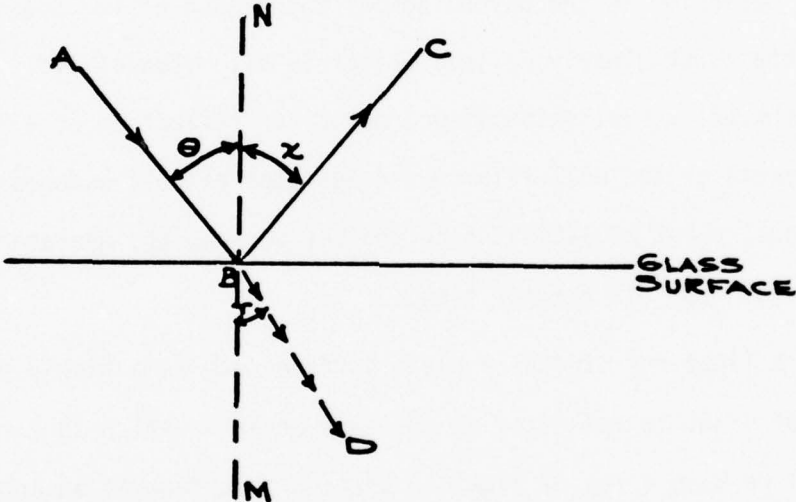

FIGURE 3.2 FIRST SURFACE REFLECTION (GLASS)

BD is the transmitted portion of the incident ray. Since  $\theta = r$ , the relationship between  $\theta$  and  $r$  can be derived, and by Snell's Law:  $\frac{\sin \theta}{\sin r} = n$ , where  $n$  is known as the refractive index of the transmitting surface. Every medium has a value of  $n$ : air is 1, glass is  $\sim 1.5$ .

Furthermore, in the case of a partially transmitting medium such as glass, portions of the transmitted ray are also reflected within the medium. Just as the incident ray is split into reflected and refracted portions, so too is the transmitted ray within the glass. Therefore, some of the internally reflected rays will emerge as extraneous light on the same side of the glass as which they entered initially (see Fig. 3.3). Therefore, it is not always possible to solve the problem of specular reflections by positioning the eyes to avoid the initial specular angle of reflection.

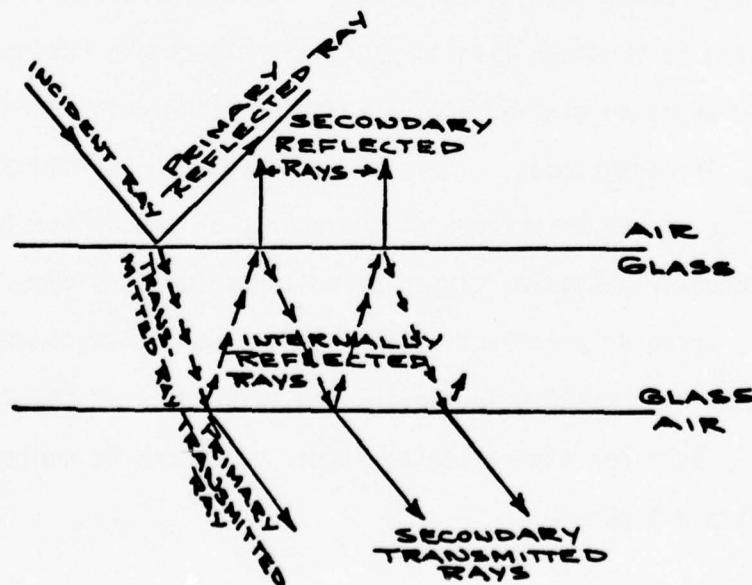

FIGURE 3.3 MULTIPLE SURFACE REFLECTIONS

The importance of this phenomenon to this study is that the problem of the various specular reflections on the PVD screen cannot be solved simply by repositioning the controllers (and thence their viewing angle) since extraneous reflections will occur at angles other than the primary specular angle. Therefore, any solution to the reflection problem must eliminate the multitudinous specular reflections by either eliminating their incident sources or by devising some means to mask their presence on the PVD screen.

Specular reflection, of course, is not always an undesirable phenomenon. Many times it is employed to heighten the contrast of an object against a background. (One implicitly employs the theory of the specularity of reflected light by searching for the specular angle at which the light might be reflected from the object into his visual field).

For the most part, good design reduces specular reflections within a visual task. According to Luckiesh (1944), specular reflections "reduce visibility and ease of seeing by being glaring and by reducing brightness contrast of critical details and their backgrounds. Their brightnesses can be reduced in proportion to the reduction of the brightness of the source or area whose image is being reflected. Whenever possible, glossy or polished surfaces should be eliminated. For moderately specularly reflecting surfaces, a sufficient increase in the level of illumination without increasing the brightness of the sources of light will completely submerge the reflected image. This can be achieved by properly directed localized light."

Luckiesh (1944) performed a study on illumination levels based on black ink on glossy paper:

"If one orients these samples near a bright source of light, he may find a position at which the ink is brighter than the paper. This is due to the fact that the Specular Reflection Factor, (SRF) of the ink is sufficiently greater than that of the paper to overcome the brightness of the paper due to diffuse and specular reflection. Such an ink is very undesirable even though it is generally somewhat "blacker" than non-glossy inks. Obviously, such specular reflection can reduce the brightness-contrast ratio between the printed matter and the background from the normally high values, of 95% or more, to very low values. This means that the visibility of the printed matter can be decreased by specular brightness to very low values and even to zero."

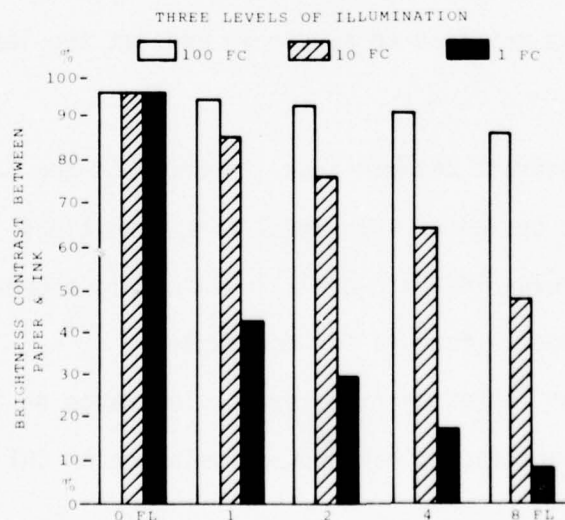

FIGURE 3.4 SPECULAR BRIGHTNESS OF PAPER AND INK (FOOT LAMBERTS)

Reading matter was printed with glossy ink on glossy paper, both with a specular reflection-factor of one percent. The specular brightness due to the reflected images of bright lighting equipment varied from 0 to 8 foot-lamberts. The visibility of the printed matter depends upon its brightness-contrast with the white paper background. It is seen that a high level of illumination tends to overcome the effects of specular reflection. For example, at 100 footcandles the brightness-contrast of the printed matter is high. At one footcandle it diminishes rapidly as the specular brightness increases.

One can see in Figure 3.4 just how much the specular reflection problem can be reduced by increasing the illumination levels. This might be accomplished by repositioning the lighting source such that the specular angle will not fall within the viewer's visual field. This is probably the simplest solution to an often complex problem.

The point to be stressed here, however, is that specular reflections cause a reduction in the contrast ratio between background and task. This reduction in contrast subsequently may lead to eyestrain and, at the least, to a loss in efficiency.

A high level of contrast between task (target) and the background should be the primary goal in the design of any visual task conditions. An increase in the contrast and a decrease in the overall luminance is a preferable condition. Gould (1968) has developed a formula for contrast:

"If  $L$  is maximum luminance (i.e. symbol luminance on CRT's) and  $D$  is minimum luminance (i.e., background luminance on CRT's), then one way

of defining luminance contrast,  $C$ , is

$$C = \frac{L-D}{L+D}. \quad (1)$$

But contrast on CRTs, unlike on hard copy, is affected by the amount of ambient illumination such that

$$L = L_i + L_e$$

$$\text{and } D = D_i + L_e$$

where  $L_i$  is the internally produced symbol luminance,

$D_i$  is the internally produced background luminance,

and  $L_e$  is the reflected ambient illuminance. Therefore,

$$C = \frac{L_i - D_i}{L_i + D_i + 2L_e}. \quad (2)$$

Because display surfaces may exhibit high diffuse and specular reflectance which may lead to poor image quality even though  $L_i$  is high, display engineers are increasingly using luminance contrast as a measurement parameter. Two important interrelated aspects of luminance contrast on CRTs are: (1) the relative luminances of  $L$  and  $D$ , and (2) gradual, compared with hardcopy, symbol-background luminance gradients, which result in relatively blurred symbols. (Gould confined his discussion to  $10 < L < 100 \text{ mL}$ )

According to Blackwell (1946), the eye is capable of detecting a luminance difference of as little as 1%. However, it must be remembered that just because there is such a capability does not imply it is an ideal situation.

In a practical attempt to determine the optimal contrast for computer-controlled CRTs, Stocker (1964) extended Blackwell's (1946, 1955, 1959) frequently cited threshold data to computer-controlled threshold displays. This attempt, which he himself subsequently questions (Stocker, 1966), failed to provide a recommendation because relative perceptual or reading speed continued to increase as contrast far exceeded that obtainable on CRTs (Gould 1968). In other words, even under optimum CRT brightness, the viewer cannot achieve the most desirable task/background ratio due to technological limitations inherent to phosphorescent cathode ray tubes.

Disability glare is thought to be influenced primarily by the total intensity of the source in the direction of the eye, and, as stated previously in this report, it is not always associated with any discomfort. Therefore, disabling glare situations often go unnoticed by the viewer until the source of the glare is eliminated or the conditions are at least improved and some difference between the before and after-conditions is observable.

Hopkinson and Collins (1962) developed a formula for measurement of direct glare:

$$\text{glare index} = 10 \log_{10} \frac{B_s^{1.6} W^{0.8}}{B_b} \times \frac{1}{p^{1.6}}$$

where  $B_s$  = source brightness in foot lamberts

$W$  = apparent size in steradians

$B_b$  = background brightness in foot lamberts

$p$  = position index (a function of the displacement of the source from the line of sight)

The Glare Index is an indication of the degree of glare sensation experienced by the general population. Utilizing this index in conjunction with practical field studies, I.E.S. has been able to develop a set of tables of recommended values to limit glare for different types of interiors.

Hopkinson and Longmore (1959) had already shown that the viewer's attention would be drawn to and held on the task with a minimum of conscious effort if the task itself is slightly brighter than the surround. However, it must be remembered that if the background is made too dark, the brightness of the task becomes a glare source in itself.

One of the primary effects of reflected glare in the visual field is its distractive nature, particularly if, as in the case of the glass-covered PVD screen, the specularly reflected images are sharp but are not in the same plane as the task images. This situation was illustrated in an experiment conducted by Petherbridge and Hopkinson (1955) in which a subject was asked to perform a reading task placed upon a polished table top. It was also arranged that images of two opal spheres would be reflected in the table top just beyond the edge of the task. Although the discomfort afforded by these sphere images proved minimal, the task-distraction they caused was extremely high.

The reduction in contrast (task/background) caused by reflected glare when at least some parts of the glare have specular reflective properties has been studied by Chorlton and Davidson (1959) with respect primarily to office and school tasks and the accompanying losses in visual performance due to reflected "sheen" on the task. The task involved in these studies was one of printed and handwritten materials, but some of the results are applicable to the CRT problem.

Their earlier experimental work (Chorlton and Davidson 1955, 1956, 1958) was carried out under the assumption that the effect of specular reflections

on the visibility of the task was primarily a function of the brightness of the light source at the mirror angle and of the glossiness of the task. But, in further tests (Chorlton and Davidson, 1959) discovered that it was not only the glare source's brightness that affected the visibility but also the entire illumination of the area. That is, the effects that specular reflections have on visibility now became a function of the "total flux on the task that was incident in the direction of the mirror angle to the angle of view of the task. The earlier method, that is, changing the brightness of the lamps in one luminance only (the one which, if a mirror had replaced the task, would be seen in the mirror), showed slightly greater losses than would have been obtained if all the lamps in the room had been changed. Current results are therefore referred to the lighting system or geometry rather than the lamp brightness, because under any given condition all of the lamps in the room were at the same brightness." Applied to the particular problem at hand (the PVD face), this implies that the specular reflection problem cannot be solved simply by removing the single image-source seen in the screen, but perhaps what is necessary is the balancing of all the light sources in the immediate surround.

G. V. Hultgren and B. Knave (1974) performed a study investigating glare problems on CRT screens. The lighting was studied in an office with 17 display terminals. The presence of discomfort glare and specular reflections was the main complaint of the employees questioned. As in the particular ARTCC situation, discomfort glare was a result of luminance differences between the dark screen and other light surfaces in the room. The reflections noted were from windows, ceilings and the ambient lighting.

The employees were given a brief questionnaire from which subjective levels of discomfort and their sources were determined. In order to objectively determine the degree of vision impairment because of glare and reflection, photographs and light measurements were taken focusing first on the text on the screen, and secondly, on the face of the screen (the reflections) itself. The results of these measurements indicated that in a number of cases the reflections had higher luminances than the texts on the screen.

In addition to the reflection problems on the face of the screen similar to that observed at the ARTCC, there is also another problem analogous to the Hultgren and Knave (1974) situation; i.e., the Radar operator must continually move his/her eyes from the dark screen to the lighter surrounds (keyboard and flight strip). Hultgren and Knave (1974) calculated a luminance between the screen and white paper on the writing table. A mean luminance ratio of 1:62 (ranging from 1:30 to 1:119) was calculated. The subjective type of discomfort reported at some of these workplaces (with low task/background ratios) corresponds closely to the previously described effects of discomfort glare. The mean luminance ratio measured between the maximum brightness of standard louvered flight strip and the background illumination of the PVD is on the order of 1:110 which is certainly within the discomfort area.

Holladay (1926) performed a series of experiments in an attempt to determine a formula for  $\Delta F$ , the minimum perceptible difference in brightness between task and background, under what he denoted as "dazzle-glare" conditions, defined as "that class of phenomena associated with bright lights in the field of view which form images upon peripheral portions of the retina and which in one way or another reduce the sensitivity of the eye for seeing objects imaged upon the

central or foveal region of the retina." In the experimentation, the illumination on the background was first adjusted to a brightness of  $F$ , and the dazzle source was then adjusted to a brightness,  $E$ , such that the task was rendered just imperceptible to the observer. Then, dazzle source was shut off and the veiling brightness source ( $B_1$ ) was adjusted to a level at which the task was once again rendered just imperceptible ( $F$  staying the same). The results for  $E/B_1$  and  $E/\Delta F_1$  were plotted against varying values of  $D$ , the angle (in degrees) between the line of vision of an observer and a line drawn from his eye to the center of the dazzle source. The two curves (Figure 3.5) showed that " $E/B_1$  and  $E/\Delta F_1$  varied approximately as  $D^2$ ; and also, that the contrast sensitivity,  $(F_1+B_1)/\Delta F_1$ , was approximately constant."

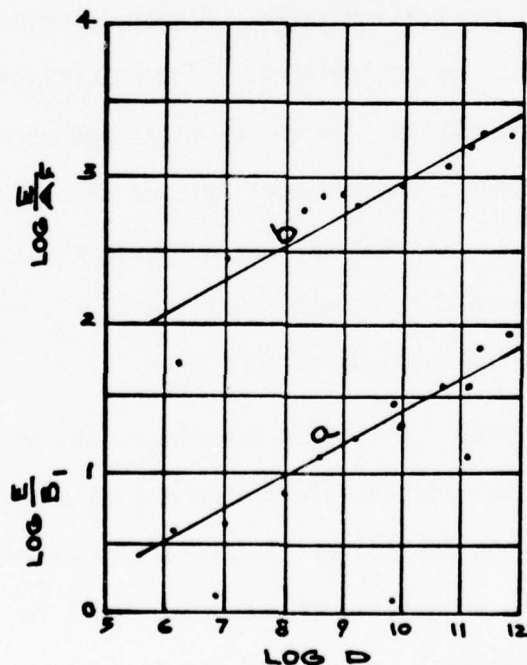

FIGURE 3.5 CURVE a SHOWS THE VARIATION WITH ANGLE  $D$  OF THE RATIO OF ILLUMINATION  $E$  FROM THE DAZZLE-SOURCE TO THE VEILING-BRIGHTNESS  $B_1$  HAVING AN EQUAL OBSCURING EFFECT; CURVE b SHOWS RELATION OF  $E/\Delta F_1$  TO  $D$ .

Wolf and Zigler (1959) investigated the threshold visibility of a test target in the vicinity of a glare source, examining the problem under varying conditions, e.g., as to the effects of size and luminance of the glare source, angular separation of glare source and target, length of exposure, and retinal location. Their conclusions were that the thresholds for target perception become lower as glare luminance and the area of the glare source are decreased, and as the distance between glare source and the target is increased, and also as the size of the target area is increased. In addition, they discovered that the threshold luminance for readability also depended upon glare luminance and angular separation between glare source and target.

Williams and Hanes (1949) studied the effects that the intensity and color of the ambient lighting have on the visibility of CRT screens. They concluded that shorter wavelength light had a slight edge over longer wavelengths in providing ambient illumination that permits ease of viewing. Also, intensity of the ambient illumination was a critical factor and they noted it was impossible to exceed the brightness of the viewing screen by more than half a log unit without subsequently reducing visibility.

One of the causes for difficulties in designing adequate ambient lighting for areas within which CRT screens are located lies in the inherent shortcomings of CRTs themselves in providing adequate illumination of the screen in high ambient source areas. Adler, Kuhns, and Brown (1953) found that when ambient luminance is of the order of 1000 mL or higher, it was impossible to make luminance of the trace signal on a CRT screen great enough to see the signal.

A trace signal of 15-20 mL can be seen if the ambient illumination is of the order of 25 to 30 times as great. They determined that the masking luminance of the ambient source increases at a decreasing rate until an asymptote at approximately 1000 mL. They concluded that an increase in the area of the true luminance and/or an increase in the duration of the signal (i.e.: the sweep on a radar scope) allow for an increased tolerance to ambient illumination.

### 3.2 Summary

A detailed examination of the problem of glare in the available literature has been made. However, the problems associated with reflected glare, especially those which are the result of specular reflections, have been given limited attention by researchers. As wider applications of the cathode ray tube are made in business and industry, research as to specular reflection problems should increase.

The theoretical research in the area of specular reflectance is often at odds with the applied situation. For example, the Luckiesh (1944) study would indicate the need for increased illumination on the flight strips to eliminate specular reflection on the flight strips from the flight strip illuminant and to improve legibility. However, by increasing the illumination of the flight strips, the Radar controller must visually scan between the dark area of the PVD and the much brighter area of the flight strip. According to Hultgren and Knave (1974) and Holladay (1926), the great disparity in intensity will cause operator eyestrain.

The literature suggests that target brightness levels presently obtainable on CRT displays do not allow for maximum task/background ratio conditions to prevail even under ideal conditions. Technological advances in phosphorescent CRT design and the use of computer generated display have solved this problem. The ARTCC problem is now one of having too great a target to background contrast which accentuates the reflections.

Size and intensity of the glare source, the angular separation between glare source and target, the color of the source, length of exposure to glare conditions, and the observer's viewing angle all are relevant factors in determining the effects of glare on an observer and in designing an optimum anti-glare and reflection environment.

#### 4.0 RECOMMENDATIONS FROM THE LITERATURE

##### 4.1 Introduction

This section of this report will deal with some of the solutions proposed by researchers in alleviating problems associated with CRT applications in high ambient illumination situations. Various authors have proposed solutions to the problems caused by direct and reflected glare in terms of CRT operation and the surrounding environment. Not all of these proposals have met with acceptance within the scientific or user communities, but their ideas will be presented in this section. Recommendations for controlling reflected glare on CRT's will be considered first. This is followed by a discussion of these authors' recommendations concerning ambient lighting in general.

##### 4.2 Control of Reflected Glare

White (1958) considers ways in which to introduce lighting to the surrounds of the CRT unit without actually having the light reach the screen itself. He recommends the use of light of a narrow wavelength band and the placement over the CRT face of a filter which absorbs that particular band of wavelengths of the spectrum. Another of his suggestions is to employ polarized light for ambient illumination along with a contrasting polarizing filter on the display screen itself.

Henry (1958) recommends the use of polarizing filters on both the general room lighting source(s) and the CRT screen. However, he further suggests that these filters be set for cross-polarization, i.e., at right angles to each other. And in order to reduce direct glare from any further ambient sources (such as the flight strip lighting and the printer) he recommends the use of black lattice

directional louvers.

Another study of the CRT screen problem was performed by Colman, Courtney, et al., (1958). They saw the problem as one of increasing the signal-to-noise ratio of the "message" emitted by the CRT screen. The "noise" is mostly a result of the fact that the phosphors used in a cathode ray tube are excited by ambient lighting as well as by the internal electron gun, and especially by light of short wavelengths. The methods most commonly employed at the time were:

- (1) reduction in the intensity and/or elimination of the interfering wavelengths of the ambient light.
- (2) rearrangement of the light sources
- (3) employment of hoods and canopies
- (4) anti-reflection coatings
- (5) circular polarizing filters

The Courtney report recommends a further refinement of the Bell Labs' "circular polarizer" technique: the circular polarizer is used to eliminate any reflections coming off the CRT screen. Unfortunately, the polarizer itself causes specular reflection problems. Therefore, Courtney suggests the use of a panel of "invisible glass" in order to eliminate these ambient light specular reflections (Figure 4.1).

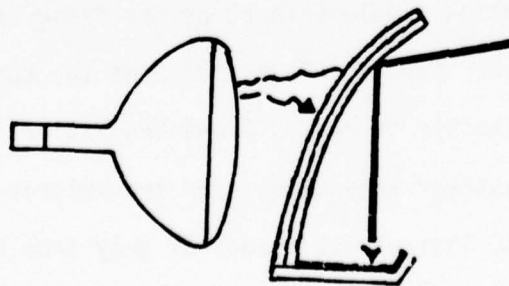

FIGURE 4.1 COMBINATION OF CIRCULAR POLARIZER AND CURVED IMPLOSION SCREEN TO FORM REFLECTION ATTENUATOR

The theory is that the polarizer layer will eliminate reflections from the face of the CRT since the reflected light cannot pass back through the circular polarizer while the signal can. The drawback to the circular polarizer is that it is good only for limited ranges in the light spectrum. The invisible glass on the other hand eliminates much of the ambient light reflections by employing the theory of specular reflections (angle of incidence = angle of reflection). Because of the curvature of the glass and polarizing layers the light is redirected harmlessly away from the operator's line of sight. The problem with the glass is the possible introduction of parallax, although the report itself does not take this facet into consideration. In any event, a prototype of this "reflection attenuator" reduced reflections by 97% and, according to the authors, the subjective response to this reduction was even greater.

Gould (1968) found that circular polarizers are indeed superior to neutral filters in both eliminating virtually all specularly reflected light and in reducing diffusely reflected light. But he, too, conceded that the polarizing surface exhibits specular reflections. He concluded along with Hyman (1967) that an anti-reflective coating on the circular polarizer is the best method available. Unfortunately, because of cost considerations, what we often find is a neutral density filter with an anti-reflective coating.

Bruns and Miller (1969) conducted a study for the U. S. Naval Missile Center in regards to lighting problems faced by the Radar Intercept Officer in the F-4J aircraft. Under certain plane attitudes the sun striking the radar screen made it impossible to read. Bruns and Miller tested 3 wire mesh filters for their contrast enhancement and transmission qualities on a test chart containing 10 logarithmic shades of gray from black to white. Their conclusions were as follows:

- (1) Under high ambient illumination, with either the open monitor or any of the three filter designs, there is more contrast between

shades of gray as the shades become lighter.

- (2) As the shades of gray become lighter, wire mesh filters provide increasingly better contrast than the open monitor.
- (3) A 2.5-mil 400-mesh experimental filter is the most effective in transmitting the display signal while deflecting and absorbing the ambient light; a 2.1-mil 200-mesh Tektronix oscilloscope filter is nearly as effective; and a 3.0-mil 325-mesh experimental filter is somewhat poorer.

The wire mesh filters have one drawback, however; i.e., under low ambient conditions (6.5 fL) there are rather high transmission losses: 200 mesh (72.6%); 325 mesh (75.1%) and 400 mesh (79.4%).

Bryden (1973) conducted a study of a high-contrast filter, embodying a color absorption filter, in an attempt to determine an optimum design. His conclusion was that color absorption filters conserve input energy to the phosphor better than a neutral filter. In displays used in high ambient light levels it is also necessary to set the phosphor brightness at a high level, thereby causing a demand for large power requirements, loss of resolution, and shortened phosphor life expectancy. Since a color filter requires less power and, therefore, less phosphor brightness, it increases both symbol resolution and phosphor life. However, neutral filters do have their advantages over the color absorption filter such as lower cost (\$100 versus \$250 per square foot), lower second-surface reflection characteristics, easier tolerance control, less weight, the ability to be used by all phosphors (including high efficiency), and usability with multi-color displays.

Smith in an internal Raytheon memo (1976) described a study conducted to choose an optimum contrast enhancement filtering system for RAYCOMP. The design was to optimize both optical and cost-effectiveness standards. His recommendations, reached after consideration of numerous possibilities (especially in regard to elimination of first surface reflections by various methods, e.g., anti-reflective coating, magnesium fluoride, etches, Don Tech,

Inc.'s RH2092 material and a polyester coating process), were as follows:

- (1) Use a SGL Homalite #1452 filter with LR-92 first surface finish. This finish diffuses the reflected light well and is economical. It is not an etch but is very similar to a light etch in appearance.
- (2) Eliminate the cosmetic panel and bond the filter to the CRT, thereby eliminating one source of loss of symbol resolution and contrast.
- (3) Use 78% transmission CRT glass since it reduces the phosphor brightness and is the only glass available now anyway.
- (4) Recommend G.E. "warm white" fluorescent bulbs as ambient lighting since they are superior to "cool white" bulbs for the contrast ratio task/background.

Amberger (1967) made a cathode ray tube employing a remission technique to provide very high contrast under high ambient conditions. The design consisted of an ultra-violet bandpass filter, a fluorescent film, and a visible bandpass filter. All elements are transparent. Incident light strikes the visible filter and is partially absorbed. The remaining ambient light passes through the fluorescent film and is absorbed by the ultra-violet filter. Since the two filter layers have no common bandpassing abilities, return diffuse reflection or emission from the fluorescent film and any return reflection from the phosphor are eliminated. Hence, the CRT maintains a high level of contrast and readability even in high ambient situations. This process, of course, still does not eliminate the problems of specular reflections, but Amberger suggests that technologically available methods (e.g., coatings, filters) be employed to reduce these reflection problems.

A study of such factors as color of the ambient illumination, intensity of illumination, angle of incidence, distance of the target from the outer surface of the CRT glass, and the complex interactions of these variables as related to anti-glare coatings was undertaken by Hampton and Carr (1967). Both objective physical and subjective observation evaluations were under-

taken. The Courtney report (1958) had advised against the use of anti-glare coatings because of high cost, limited wave-length effectiveness, and the problem of fingerprints and other foreign matter reducing the effectiveness of the coating. However, Hampton and Carr (1967) no longer saw these as reasons against anti-glare coatings. First, the cost of such coatings is no longer prohibitive. Second, they are effective over broad ranges of the visible spectrum (400-700m $\mu$ ). And, lastly, any glass, coated or uncoated, is susceptible to the adverse effects of fingerprints or dust. In addition, present anti-glare glass does meet the stringent requirements of military specifications for humidity, temperature, salt-spray resistance, abrasion, and adhesion tests. The HEA coating tested was cleanable with any common solvent or cleaning solution.

Three coatings were tested: HELR, HEA, and circular polarizer with HEA, along with a test-standard uncoated glass. The results of reflectance tests under white ambient lighting conditions indicated that the HEA, with or without polarizing filter, gave almost identically marked improvement over either the HELR or uncoated glass. The reduction of the angle of incidence from 30<sup>0</sup> to 15<sup>0</sup> also produced a small reduction in measured reflected light values while an increase in ambient intensity, as expected, produced almost linearly increasing reflection measurements. The transmittance measurements showed significant differences for the different coatings: the HEA with circular polarizer allowed only 30%; HELR and the uncoated safety glass allowed 88%, and the HEA coating alone allowed nearly 100% (almost 12% better than the uncoated glass).

Hampton and Carr concluded that the HEA coating on both sides of the glass represented the most effective of all the test coatings. Although the circular polarizer with HEA coating had slightly better anti-reflectance characteristics, the low transmittance quality of such a combination precludes its desirability.

Spanier, et al (1972) have developed a patented anti-reflective glass. According to its inventors this new type of glass combines etching with an optical coating in such a way that reflected light is several orders of magnitude less than that reflected by prior state-of-the-art optical coatings, e.g., reflected light (250-675m $\mu$ ) measured off conventional optical coatings at 0.6% reflectance were unmeasurable under this method, but were estimated at 0.1 to 0.01%.

Reported advantages of this method were:

- (1) Greater reduction of specular reflections with less loss of symbol resolution than with etching alone.
- (2) Greater reduction of non-specular reflections than that obtainable using optical coatings.
- (3) Significant reduction of the adverse effects of oily films (fingerprints, etc,)
- (4) Higher resistance to abrasion.
- (5) Greater effective viewing angle than with optical coatings alone which are viewing angle sensitive.

In addition, the extent of etching is dependent upon the particular resolution needs of the tasks being performed. It is claimed that the commercially available etched panels labeled "fine" or "light" provide the correct resolution for CRT displays (determined as not less than 1.1255 line-pairs/mm and not greater than 3.5636 line-pairs/mm). Any preferred anti-reflective chemical coating can then be applied to the previously etched glass. This is similar to the process used on the Computer Readout Display (CRD) for Computer Update Equipment. If this process works as well as reported, a breakthrough has been made in CRT anti-glare technology.

#### 4.3 Ambient Lighting Recommendations

Ambient lighting in the ARTCC centers provides certain problems in relation to the PVD display. Among these problems are the reflections of the walls and ceilings on the PVD screen because of the room lighting and the

glaring light sources connected with the flight strip and printer area. Up to a point the more light the eyes receive, the better they function; but beyond that point glare interferes. A minimum of 200 lux for rough work and up to 2,000 lux for fine and detailed work should be provided (IES Handbook 1972).

The problem here is that the surround of the PVD area should be darker than that of the adjoining flight strip area. The ideal solution, from an illumination engineer's perspective, would be to separate the two areas by space or by some sort of dividing curtain. Unfortunately neither is a possibility in this case because of the working relationship between the PVD operator and flight strip operator. Therefore, suitable means must be devised to limit the adverse effects of the "spillover" of light from one area to the next. In addition, adequate ambient room lighting is necessary to allow for safe travel about the floor area by supervisors and controllers at all times.

The Ralph M. Parsons Company (1970) conducted a study in order to determine the most desirable integrated lighting system for ARTCC centers in terms of cost, energy conservation, and illuminating efficiency. The following conclusions were reached after considerable scientific experimentation and elimination of what they saw as undesirable alternatives:

- (1) PVD's operating at a  $6^\circ$  angle from the horizontal will work effectively with two rows of direct lighting installations. No glare or high contrast images appear on the screen.
- (2) PVD's operating at a  $68^\circ$  angle from the horizontal pick up images of the farthest row of lights only. Use of high cut-off angle louvers over these lights will reduce these reflections. Gray matte louvers and supplementary lighting that will not mask out displays or cause discomfort glare should be employed.
- (3) The Computer Readout Display (CRD) for Computer Update Equipment will pick up images of the near row of lights if mounted in a position parallel with the existing console surface. Supplementary lighting and louvers will make the light source more uniform and thereby reduce the contrast of the background to the PVD surface. Tilting the mounting of the PVD can eliminate the louver surface image for some observers.
- (4) Map light boards do not pick up any unwanted reflections from a direct lighting installation.

- (5) Use of louvers with a  $68^\circ$  cut-off angle over the overhead lights eliminates any direct-glare exposure.
- (6) Supplementary lighting to lighten walls and ceilings and blend with the louvers is necessary as direct lighting fixtures with high cut-off angles do not adequately illuminate walls or ceilings.
- (7) The supplementary lighting of walls and ceilings should be of the indirect type and it must not be used in establishing proper working level illumination.

The most important point to notice in the conclusions and recommendations of the Parsons' report is that direct lighting with high angle ( $68^\circ$ ) louvers should provide the primary ambient lighting for the facility. This was never implemented. In addition, the mapboards are the largest single sources of specular reflections on the PVD and a study of their effects seem to have been overlooked in this study.

The conclusion that direct lighting is the most efficient means of lighting the room is disputed by Lewin (1973). In his article he designs and attempts to validate his claim to the superiority of his "twin-beam" system (Figure 4.2) of luminaire design over any conventional method. A photometric curve (Figure 4.3) of the illumination cast by such a system shows almost all light being cast out at angles between  $20^\circ$  and  $40^\circ$  with predominant emphasis at the  $30^\circ$  angle. His system increased the Contrast Rendition Factor (CRF) and virtually eliminates any veiling reflection problems by eliminating specular reflections from the task field of view. In addition, the "twin-beam" system provides an almost constant value of CRF across the entire center of his test room, from which we might infer that the "twin-beam" luminaire design provides for balancing of the illumination of the surround very effectively.

In addition, this system is highly efficient in the production of light. In comparing a louver system, a lens system, and his "twin-beam" system, Lewin arrived at the values of 30 Equivalent Sphere Illumination (ESI) fc, 51 ESI fc, and 78 ESI fc, respectively for the three systems. In terms of ESI fc per kilowatt we get 27.3 fc/kw, 30.9 fc/kw and 56.58 fc/kw. The "twin-beam" system becomes twice as cost effective as the louver system and almost one and a half times as effective as the conventional lens system. Such a system may not be practical for the ARTCC centers in terms of installation cost.

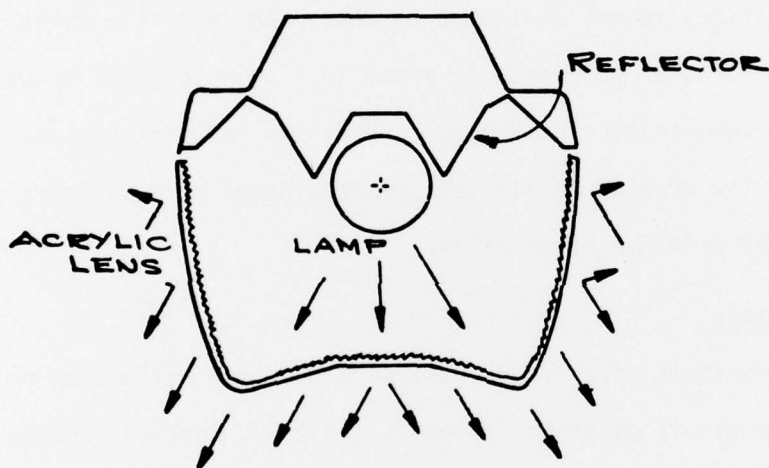

FIGURE 4.2 LUMINAIRE FOR VEILING REFLECTION CONTROL

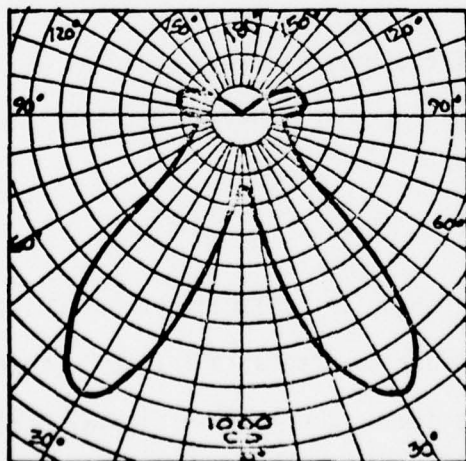

FIGURE 4.3 PHOTOMETRIC CURVE FOR TWIN-BEAM LUMINAIRE ACROSS-AXIS PLANE

## 5.0 SUMMARY OF RECOMMENDATIONS

### 5.1 Circular Polarizers

Circular polarizers effectively reduce specular reflections from the face of a CRT screen. However, they cause several secondary problems: (1) they are useful only for limited ranges of the light spectrum (2) they reduce the transmittance of the light from the screen to the observer, (3) specular reflections appear on the face of the circular polarizer itself and (4) they are very expensive. The Courtney report's attempt to design an invisible glass shield to be placed over the circular polarizer in order to eliminate these specular reflections seems to complicate the problem rather than solve it because (1) it does not eliminate the problem of limited spectrum range of polarizers and (2) the glass introduces problems of parallax.

### 5.2 Wire Mesh Filters

Wire mesh techniques effectively eliminate specular reflection problems, but under the low ambient conditions found in the ARTCC control centers wire mesh filters lower the transmittance of light to unacceptable levels.

### 5.3 Color/Neutral Filters

Color/neutral filters effectively increase the contrast between the characters and the screen background. However, they do nothing to eliminate specular reflection problems.

### 5.4 Etches

Etches tend to eliminate specular reflections, but unless the etching is carefully controlled, it may cause unacceptable losses in character resolution, thereby leading to eye fatigue due to the loss in display legibility.

### 5.5 Optical Coating

Optical coatings probably provide the best method of reducing specular reflections. Hampton and Carr (1967) determined that glass coated on both sides by an HEA coating provides the most efficient coating available. But, inherent problems with coatings still exist: (1) they do not reduce non-specular reflections; (2) they are susceptible to loss of resolution by oily films and fingerprints; (3) they are not resistant to abrasion and (4) they are viewing-angle sensitive.

### 5.6 Etching and Optical Coating

The process developed by Spanier et al (1972) combining etching and optical coatings is a first step to answering this problem of reflections on the PVD face. This process apparently eliminates all the objections to etching. It also eliminates all of the problems associated with optical coatings with the exception of applicability to non-glass surfaces. If the non-glass implosion shield could be placed between the face of the CRT and the faceplate, the process would show considerable merit.

### 5.7 Ambient Lighting

In addition to the specular reflection problem there is also a problem of the ambient lighting in the environment. The room lighting must be balanced to eliminate the light/dark contrasts found on the walls and ceiling. The recommendations of the Parsons' report have not been followed in their entirety. They do not deal adequately with the PVD reflection problem. The present installations are incapable of being balanced effectively and persist in causing specular reflections on the PVD face.

The Lewin (1973) "twin-beam" system may be applicable to the ambient lighting problem, but would require a costly installation.

## REFERENCES

Adler, Kuhns, and Brown, Masking of Cathode Ray Tube Displays by Ambient Illumination. Wade Technical Report 53-216, Wright Air Development Center, Dayton, Ohio, November, 1953.

Amberger, O., A Cathode Ray Tube Suitable for Viewing Under High Ambient. NASA CR-1185 for Electronics Research Center, NASA, 1967.

Baker, C.A., and Grether, W. F., Visual Presentation of Information. In Human Engineering Guide to Equipment Design, Morgan, C. T., ed., New York: McGraw-Hill, Chp. 2, 51-69.

Blackwell, H. R., Contrast Thresholds of the Human Eye. Journal of the Optical Society of America, 1946, 36, 624-643.

Blackwell, H. R., Use of Performance Data to Specify Quantity and Quality of Interior Illumination. Illumination Engineering, 1955, 286-299.

Blackwell, H. R., Specification of Interior Illumination Levels. Illumination Engineering, 1959, 317-353.

Bruns, R. A. and Miller, P. L., Light Transmission Characteristics of Three Wire-Mesh Filters. Naval Missile Center, Point Magu, Ca., May, 1969.

Bryden, J. E., High Contrast Filters for CRT's. Raytheon Co. Report: E.R. #73-4430, December, 1973.

Chorlton, J. M. and Davidson, H. F., Reflected Glare Studies. Committee Report to the IES School Lighting Committee, August 8, 1956.

Chorlton, J. M. and Davidson, H. F., Measurement of Contrast Losses in School and Office Tasks--An Example from Toronto Schools. From a report at the Second Research Symposium, Illuminating Engineering Research Institute, March, 1958.

Chorlton, J.M., and Davidson, H.F., The Effect of Specular Reflection on Visibility -- Part II -- Field Measurements of Loss of Contrast. Illuminating Engineering, 54:8, August, 1959, p. 482.

Colman, K. W., Courtney, D., Freeman, J. B., and Berstein, R., The Control of Specular Reflections from Bright Tube Radar Displays. Courtney and Co. Technical Report 23, Philadelphia, Penn., November 15, 1958.

Gould, J. D., Visual Factors in the Design of Computer Controlled CRT Displays. Human Factors, 1968, 10, 359-376.

Hampton, D. and Carr, R., Evaluation of Anti-Glare Coatings for Use in the BQS-13 Sonar System. Raytheon Co.: Contract N0bsr 93138, Task C, February 20, 1967.

Henry, F. G., Some Applications of Controlled White Lighting. Illumination and Visibility of Radar and Sonar Displays, R. H. Brown, ed., April, 1958.

Holladay, L. L., The Fundamentals of Glare and Visibility. Journal of the Optical Society of America, 1926, 12:4, 271-319.

Hopkinson, R. G. and Collins, J. B., The Prediction and Avoidance of Glare in Interior Lighting. A paper delivered to the Industrial Section of the Ergonomics Research Society, March 1, 1962.

- Hopkinson, R. G. and Longmore, J., Attention and Distraction in the Lighting of Work Places. Ergonomics 2, 1959, p. 321.
- Hultgren, G. V., and Knave, B., Discomfort Glare and Disturbances from Light Reflections in an Office Landscape with CRT Display Terminals. Applied Ergonomics, 1974, 5:1, 2-8.
- Hyman, C. E., Anti-Glare Coatings for Computer-Controlled CRT's. Yorktown Heights: IBM Technical Note, TN21. 575-23, August, 1967.
- IES Lighting Handbook, Fifth Edition. Baltimore: Waverly Press, 1972.
- Lewin, I., Luminaire Design Related to Visibility. IEEE Trans. Ind. Appl., Vol. IA-9, no. 5, September-October, 1973.
- Luckiesh, M., Light, Vision, and Seeing. New York: D. van Nostrand Co., Inc., 1944.
- Parsons, R. A., and Co., Expansion and Modernization of Air Route Traffic Control Centers, Volume V, Control Room Lighting Tests. Department of Transportation, FAA, Washington, D. C., July 27, 1970.
- Smith, F. E., Raycomp Contrast Enhancement Filter. Sudbury: Raytheon Equipment Division, Internal Memo No. FES-76-07, March 31, 1976.
- Spanier, G., et al, Anti-Reflective Glass (patent application). Dept. of Transportation Report No. DOT/Case-A-00177, PAT-APPL-241 840, filed April 6, 1972.

Stocker, A. C., Displays, Papers, and Lighting. The Visual System in Command Centers. Info. Display, September-October, 1964, 1, 16-26.

Stocker, A. C., The Size and Contrast of Hard-Copy Symbols. Info. Display, July-August, 1966, 3, 36-42.

White, C. T., The Rationale for Use of Controlled White Light in Radar and Sonar Spaces. In illumination and Visibility of Radar and Sonar Displays. R. H. Brown, ed., April, 1958.

Williams, S. B., Visibility on Cathode-Ray Tube Screens: Viewing Angle. Journal of the Optical Society of America, 1949, 39, 782-785.

Williams, S. B., and Hanes, R. M., Visibility on Cathode-Ray Tube Screens: Intensity and Color of Ambient Illumination. Journal of Psychology, 1949, 27, 231-244.

Wolf, E., and Zigler, M. J., Some Relationships of Glare and Target Perception. WADC Technical Report 59-394, Aerospace Medical Laboratory, Wright Air Development Center, Wright-Patterson Air Force Base, Ohio, September, 1959.

APPENDIX D

ILLUSTRATIONS OF IMPROVEMENTS BY THE MODIFICATIONS  
OF THE BOSTON ARTCC LIGHTING STUDY

APPENDIX D

ILLUSTRATIONS OF IMPROVEMENTS BY THE MODIFICATIONS  
OF THE BOSTON ARTCC LIGHTING STUDY

<u>Figure</u>	<u>Title</u>	<u>Page</u>
D-1	Increased Ambient Illumination in Area D (Background of Photograph) From Light Control Mapboards	D-2
D-2	Flight Strip Illumination With Three-Inch Deep Louvers	D-3
D-3	Flight Strip Printer Illumination With Green Filter	D-4
D-4	Black Negative Keycaps on Plan View Display	D-5



FIGURE D-1  
INCREASED AMBIENT ILLUMINATION IN  
AREA D (BACKGROUND OF PHOTOGRAPH) FROM  
LIGHT CONTROL MAPBOARDS



FIGURE D-2  
FLIGHT STRIP ILLUMINATION WITH THREE-  
INCH DEEP LOUVERS

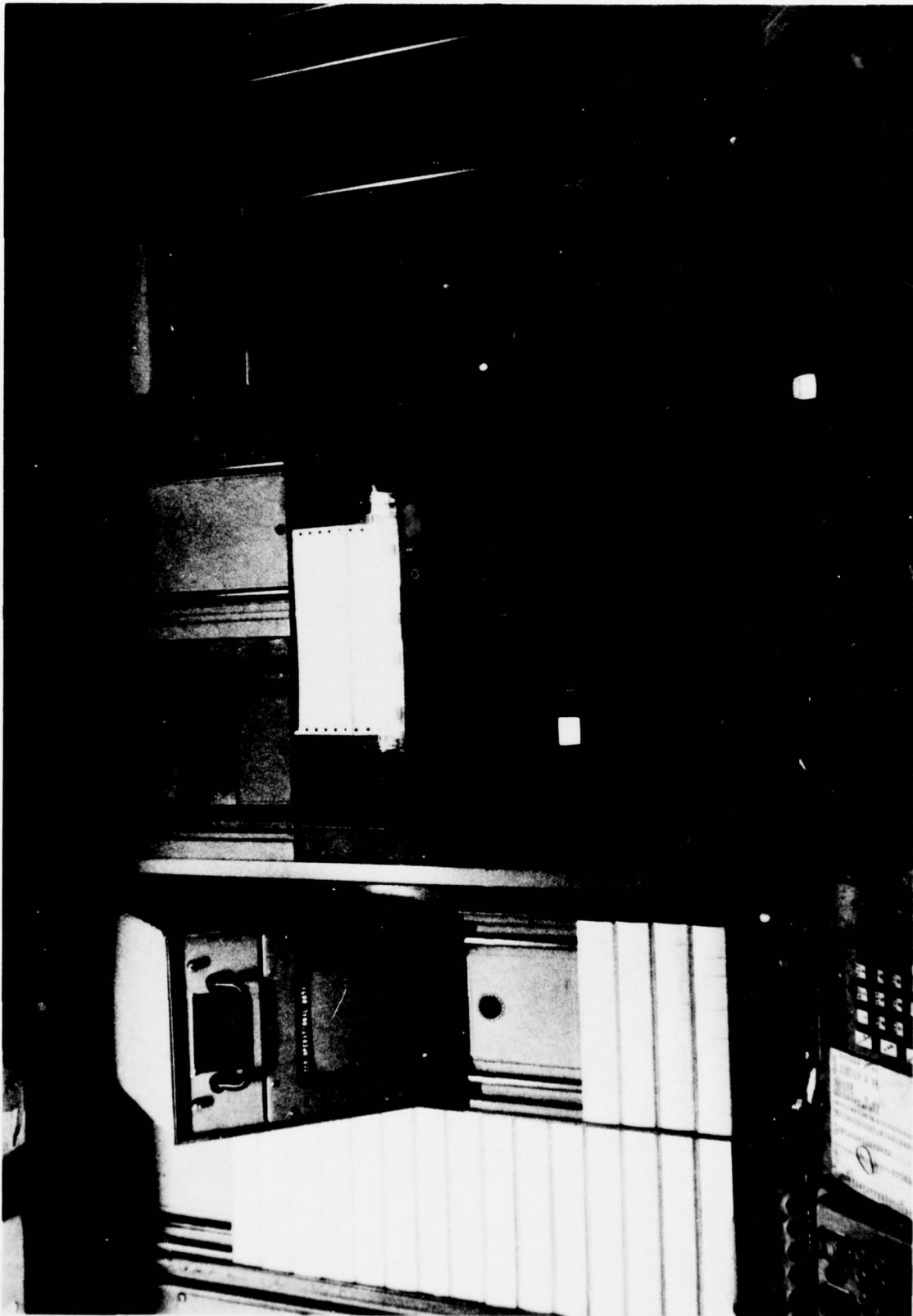

FIGURE D-3  
FLIGHT STRIP PRINTER ILLUMINATION  
WITH GREEN FILTER

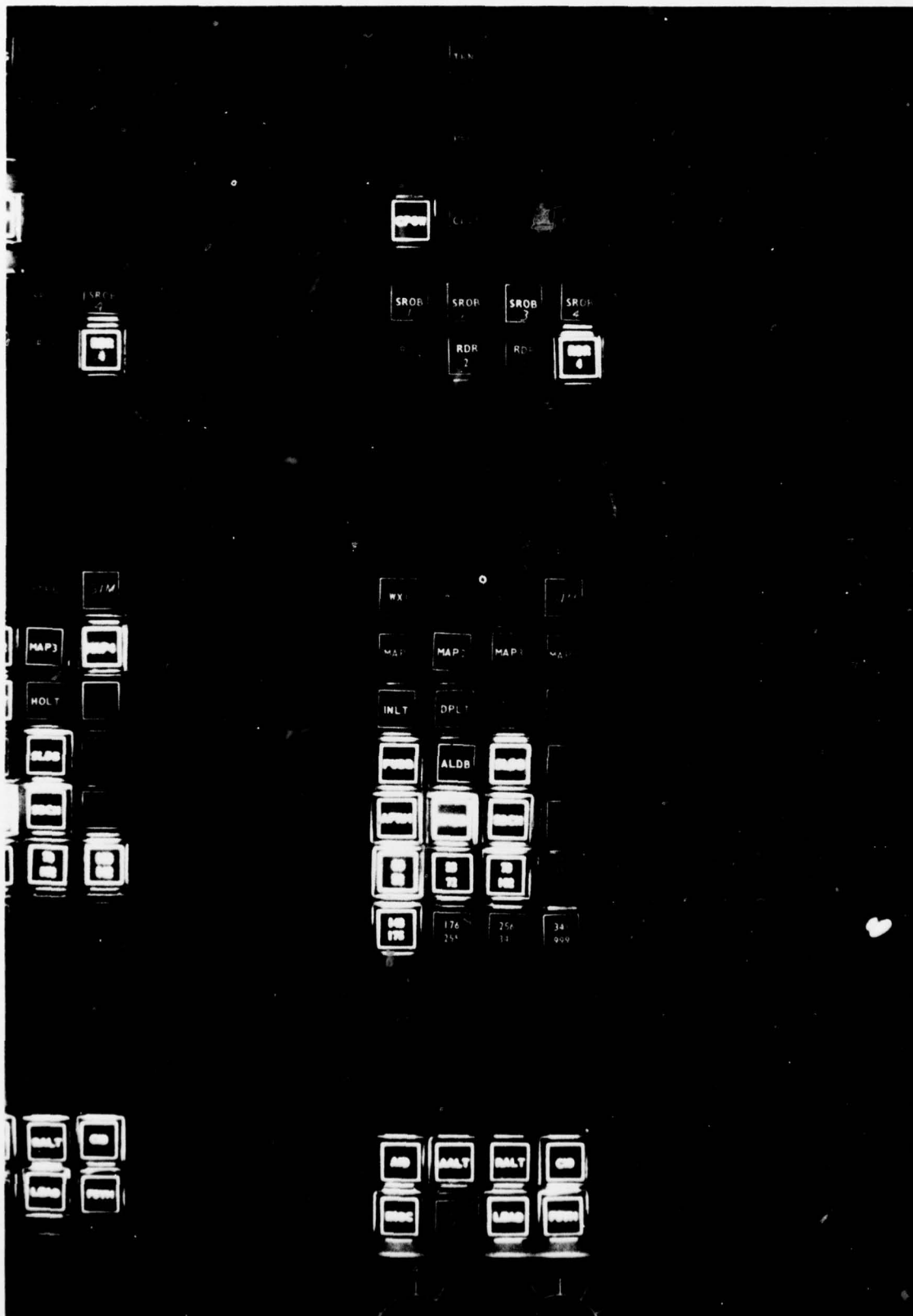

FIGURE D-4  
 BLACK NEGATIVE KEYCAPS ON  
 PLAN VIEW DISPLAY