

AD-A041 371

MICHIGAN UNIV ANN ARBOR DEPT OF INDUSTRIAL AND OPERA--ETC F/G 6/19  
THE VISUAL BEHAVIOR OF RECREATIONAL BOAT OPERATORS AND ITS RELA--ETC(U)  
MAY 77 J M MILLER, D R DYKSTRA, S M GATCHELL DOT-CG-61098-A  
USCG-D-31-77 NL

UNCLASSIFIED

1 OF 2  
AD  
A041371

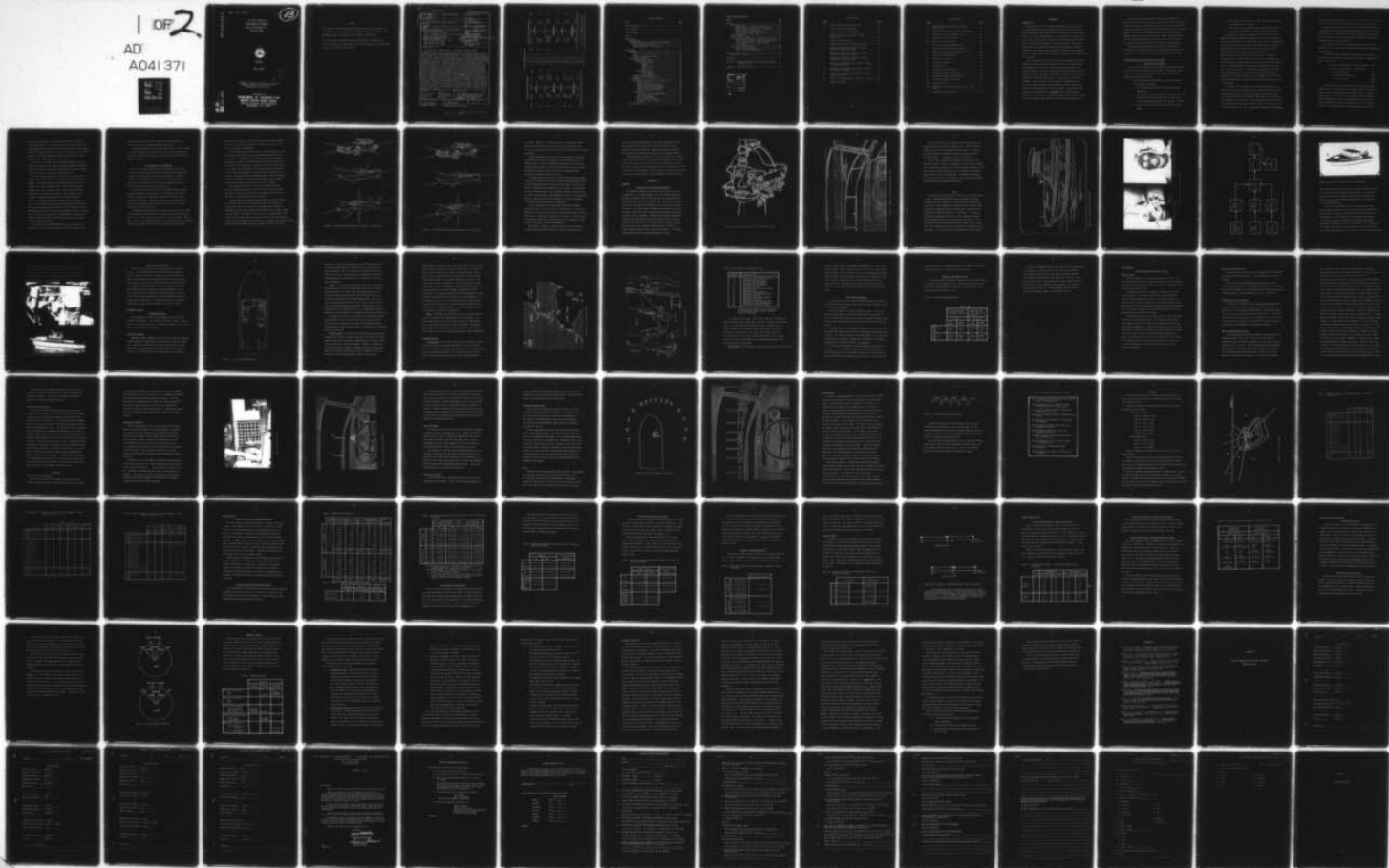

AD A 041371

Report No. CG-31-77

13

THE VISUAL BEHAVIOR OF  
RECREATIONAL BOAT OPERATORS  
AND ITS RELATIONSHIP TO  
BOAT COLLISIONS



MAY 1977

FINAL REPORT

D D C  
RECORDS  
JUL 6 1977  
REGISTRATION  
D

Document is available to the public through the  
National Technical Information Service,  
Springfield, Virginia 22151

AD No. \_\_\_\_\_  
DDC FILE COPY

Prepared for  
**DEPARTMENT OF TRANSPORTATION**  
**UNITED STATES COAST GUARD**  
Office of Research and Development  
Washington, D.C. 20590

NOTICE

This document is disseminated under the sponsorship of the U. S. Department of Transportation in the interest of information exchange. The United States Government assumes no liability for the contents or use thereof.

The United States Government does not endorse products or manufacturers. Trade or manufacturers' names appear herein solely because they are considered essential to the object of this report.

Cover 2

3x4x

10 J.M. Miller; W.R. Dykstra  
S.M. Gatchell

Technical Report Documentation Page

|   |  |   |
|---|--|---|
| 1. Report No. 19<br>18 US CG-D-31-77  | 2. Government Accession No.  | 3. Recipient's Catalog No. 11   |
| 4. Title and Subtitle<br>6 THE VISUAL BEHAVIOR OF RECREATIONAL BOAT OPERATORS and its Relationship to Boat Collisions.  | 5. Report Date<br>26 May 77  | 6. Performing Organization Code   |
| 7. Author(s)<br>Miller, J.M.; Gatchell, S.M.; Dykstra, D.R.   | 8. Performing Organization Report No. 1299p.   | 10. Work Unit No. (TRAIS) 13  |
| 9. Performing Organization Name and Address<br>The University of Michigan<br>Dept. of Industrial and Operations Engineering<br>2260 G.G. Brown Laboratory<br>Ann Arbor, Michigan 48109  | 11. Contract or Grant No.<br>DOT-CG-61098-A  | 12. Type of Report and Period Covered<br>Final Report, for period Summer 1976 |
| 12. Sponsoring Agency Name and Address<br>U.S. Coast Guard (GFCP/S -- 71)<br>400 Seventh Street, S.W.<br>Washington, D.C. 20590   | 13. Sponsoring Agency Code<br>G-DSA  |   |
| 15. Supplementary Notes<br>U. S. Coast Guard Project Officer: Ens Steven F. Wiker (G-DSA)   |  |   |
| 16. Abstract<br>A 22-foot boat was instrumented to provide closed-circuit TV recording capabilities of head and eye movements. Four experienced boaters operated the test vehicle at low and high levels of: fatigue, velocity, and traffic density. The visual characteristic variables derived included: means and standard deviations by degrees of horizontal and vertical eye fixations; the percentage time spent in visual zones; the percent time spent looking at different objects (i.e., other boats); and eye fixation durations. At the higher fatigue level, subjects spent less time looking at the instrument panel and lowered their fixation pattern from above to below the horizon. Low fatigue did not affect the dispersion of the horizontal looking fixations as traffic density increased, but the high fatigue affected this dispersion at both low and high density levels. These findings suggest a tendency at higher fatigue levels for subjects to (a) neglect the secondary tasks and (b) have a deterioration in peripheral vision (sometimes called the "tunnel vision" effect). The larger dispersion of foveal fixation looks may have been a means of compensating in part for this effect. It was also suggested that difficulty in observing traffic may be caused by the visual interference of the boat's structure and windshield design. This may cause a greater influence on visual behavior at the higher fatigue levels. The implications of the above to future research and prevention of boating collision are discussed. |  |   |
| 17. Key Words<br>design<br>visual behavior<br>collisions<br>eye movements<br>velocity<br>head movements<br>traffic density<br>boat operators<br>fatigue   | 18. Distribution Statement<br>This document is available to the U.S. public through the National Technical Information Service, Springfield, VA 22161. |   |
| 19. Security Classif. (of this report)<br>Unclassified  | 20. Security Classif. (of this page)<br>Unclassified   | 21. No. of Pages<br>92  |
|   |  | 22. Price   |

Form DOT F 1703.7 (8-72)

Reproduction of completed page authorized

403871

U.S. GOVERNMENT PRINTING OFFICE: 1973 725-504/328

VB

## METRIC CONVERSION FACTORS

| Approximate Conversions to Metric Measures |                        |                            | Approximate Conversions from Metric Measures |                 |                                   |  |
|--|------------------------|----------------------------|--|-----------------|-----------------------------------|--|
| Symbol                                     | When You Know          | Multiply by                | To Find                                      | Symbol          | When You Know                     |  |
| <b>LENGTH</b>                              |                        |                            |  |                 |                                   |  |
| in   | inches                 | 0.0254                     | centimeters                                  | mm              | millimeters                       |  |
| ft   | feet                   | 0.3048                     | centimeters                                  | cm              | centimeters                       |  |
| yd   | yards                  | 0.9144                     | meters                                       | m               | meters                            |  |
| mi   | miles                  | 1.60934                    | kilometers                                   | km              | kilometers                        |  |
| <b>AREA</b>                                |                        |                            |  |                 |                                   |  |
| in <sup>2</sup>                            | square inches          | 6.4516                     | square centimeters                           | cm <sup>2</sup> | square centimeters                |  |
| ft <sup>2</sup>                            | square feet            | 0.0929                     | square meters                                | m <sup>2</sup>  | square meters                     |  |
| yd <sup>2</sup>                            | square yards           | 0.8361                     | square meters                                | m <sup>2</sup>  | square meters                     |  |
| mi <sup>2</sup>                            | square miles           | 2.59                       | square kilometers                            | km <sup>2</sup> | square kilometers                 |  |
|  | acres                  | 0.4047                     | hectares                                     | ha              | hectares (10,000 m <sup>2</sup> ) |  |
| <b>MASS (weight)</b>                       |                        |                            |  |                 |                                   |  |
| oz   | ounces                 | 28.3495                    | grams  | g               | grams                             |  |
| lb   | pounds (2000 lb)       | 0.453592                   | kilograms                                    | kg              | kilograms                         |  |
|  | short tons             | 0.907185                   | tonnes                                       | t               | tonnes (1000 kg)                  |  |
| <b>VOLUME</b>                              |                        |                            |  |                 |                                   |  |
| tsp  | teaspoons              | 5                          | milliliters                                  | ml              | milliliters                       |  |
| Tbsp                                       | tablespoons            | 15                         | milliliters                                  | ml              | milliliters                       |  |
| fl oz                                      | fluid ounces           | 30                         | milliliters                                  | ml              | milliliters                       |  |
| c  | cups                   | 0.24                       | liters                                       | l               | liters                            |  |
| pt   | pints                  | 0.47                       | liters                                       | l               | liters                            |  |
| qt   | quarts                 | 0.95                       | liters                                       | l               | liters                            |  |
| gal  | gallons                | 3.8                        | liters                                       | l               | liters                            |  |
| ft <sup>3</sup>                            | cubic feet             | 0.03                       | cubic meters                                 | m <sup>3</sup>  | cubic meters                      |  |
| yd <sup>3</sup>                            | cubic yards            | 0.76                       | cubic meters                                 | m <sup>3</sup>  | cubic meters                      |  |
| <b>TEMPERATURE (exact)</b>                 |                        |                            |  |                 |                                   |  |
| °F   | Fahrenheit temperature | 5/9 (after subtracting 32) | Celsius temperature                          | °C              | Celsius temperature               |  |
| °C   | Celsius temperature    | 9/5 (then add 32)          | Fahrenheit temperature                       | °F              | Fahrenheit temperature            |  |

\*1 in. = 2.54 (exact). For other exact conversions and more detailed tables, see NBS Misc. Publ. 286, Units of Weights and Measures, Price \$2.25, SD Catalog No. C13.10.286.

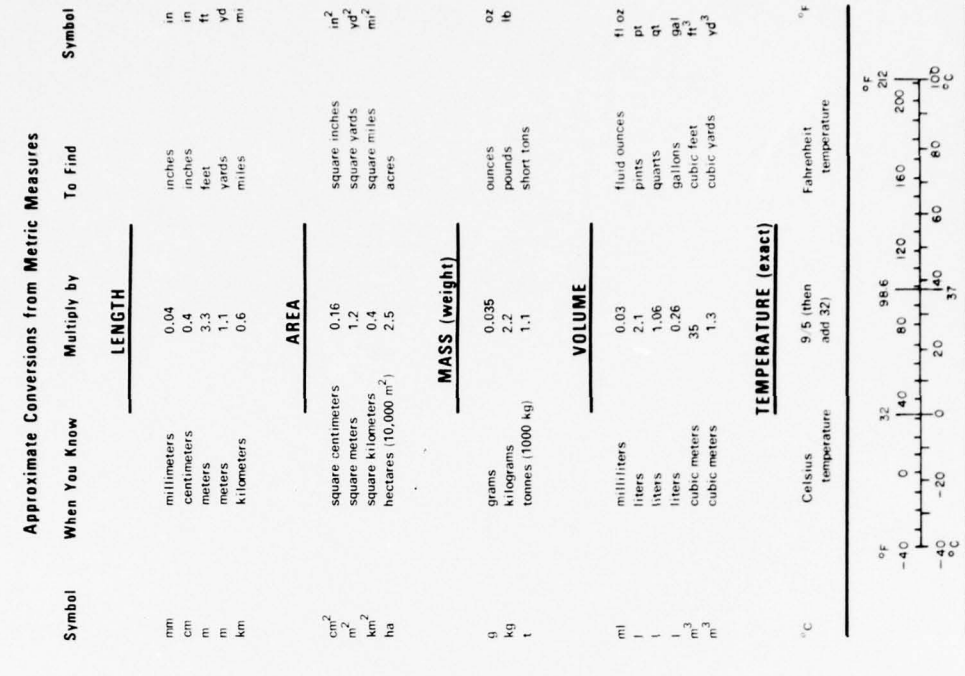

TABLE OF CONTENTS

| <u>Title</u>   | <u>Page</u> |
|--|-------------|
| Table of Contents.....                               | i           |
| List of Tables.....                                  | iii         |
| List of Figures.....                                 | iv          |
| Abstract   |             |
| Background.....                                      | 1           |
| Introduction.....                                    | 1           |
| Literature Relevant to Collision and Visibility..... | 2           |
| BAR Data and Wyle Studies.....                       | 2           |
| The Automobile vs. Boat Operator.....                | 6           |
| Methodology.....                                     | 10          |
| Equipment.....                                       | 10          |
| Visual Activity Monitoring (VAM) System.....         | 10          |
| Boat.....  | 13          |
| Layout of Experimental Boat.....                     | 19          |
| Experimental Design.....                             | 19          |
| Independent Variables.....                           | 19          |
| Controlled Variables.....                            | 19          |
| Subjects.....  | 19          |
| Fatigue.....   | 21          |
| Tasks and Route.....                                 | 21          |
| Speed.....   | 22          |
| Measured Variables.....                              | 22          |
| Traffic Density.....                                 | 22          |
| Environmental.....                                   | 25          |
| Visual Behavior Measures.....                        | 26          |
| Summary of Experimental Design.....                  | 27          |
| Test Procedure.....                                  | 29          |
| Pre-Testing and Preparation of Subjects.....         | 29          |
| Subject Consent.....                                 | 29          |
| Physical and Experience Data.....                    | 30          |
| Helmet and Bite-Bar Fabrication.....                 | 30          |
| Boat and Route Familiarization.....                  | 30          |
| Practice Wearing VAM Helmet.....                     | 32          |
| Test Phase.....                                      | 32          |
| Face Camera and Seat Adjustments.....                | 32          |
| VAM System Calibration.....                          | 33          |
| Run #1 with Helmet.....                              | 36          |
| Run #2 without Helmet.....                           | 36          |
| Peripheral Target Viewing.....                       | 37          |
| Run #3.....  | 37          |
| Data Reduction.....                                  | 40          |



Table of Contents (cont.)

| <u>Title</u>  | <u>Page</u> |
|---|-------------|
| Results.....  | 43          |
| Fatigue Effects.....  | 48          |
| Fatigue Effects in Visual Zone Percentages.....                                   | 48          |
| Fatigue Effects in Mean Fixation Location.....                                    | 48          |
| Fatigue-Velocity Interaction.....   | 50          |
| Fatigue-Traffic Density Interaction.....  | 52          |
| Fatigue-Subject Interaction.....  | 53          |
| Velocity Effects.....   | 54          |
| Traffic Density Effect.....   | 56          |
| Visual Zone Percentages - Density vs. Velocity....                                | 56          |
| Traffic Density Effect on Mean Fixation Location..                                | 57          |
| Traffic Density Effect on Objects Viewed<br>Percentages.....                      | 57          |
| Results from Related Studies.....   | 59          |
| Looking Time Durations.....   | 59          |
| Effects of Wearing VAM Helmet.....  | 59          |
| Summary of Results.....   | 62          |
| Discussion of Results.....  | 66          |
| References.....   | 71          |
| Appendix A: Physical Dimensions and Personal Experience<br>Information Forms..... | 72          |
| Appendix B: Additional Figures.....   | 87          |

|                                  |   |
|----------------------------------|---|
| <b>ACCESSION for</b>             |   |
| ATIS                             | Write Section <input checked="" type="checkbox"/> |
| DCC                              | Buff Section <input type="checkbox"/>             |
| UNANNOUNCED                      | <input type="checkbox"/>                          |
| JUSTIFICATION.....               |   |
| BY.....                          |   |
| DISTRIBUTION/AVAILABILITY CODES  |   |
| REMARKS: A, B, C, and/or SPECIAL |   |
| A                                |   |

D D C  
RECEIVED  
JUL 6 1971  
RECORDS

4

LIST OF TABLES

| <u>TABLE</u> | <u>PAGE</u>  |
|--------------|--|
| 1A           | Route Segments and Navigation Task . . . . . 25  |
| 1B           | The Experimental Design Matrix . . . . . 27  |
| 2            | Measures Recorded by Data Reducer . . . . . 42   |
| 3            | Results of Analysis of Variance (ANOVA) -<br>Main Effects . . . . . 45                       |
| 4            | Visual Zone Percentages (%) . . . . . 49   |
| 5            | Fatigue Effects in Visual Zone Percentages . . . . . 49                                      |
| 6            | Horizontal and Vertical Fixation Locations -<br>Means and Standard Deviations . . . . . 50   |
| 7            | Horizontal and Vertical Fixation Locations -<br>Fatigue vs. Velocity Cell Means . . . . . 51 |
| 8            | Horizontal and Vertical Fixation Locations -<br>Fatigue vs. Density Cell Means . . . . . 52  |
| 9            | Horizontal and Vertical Look Location - Fatigue<br>vs. Subject Cell Means . . . . . 53       |
| 10           | Horizontal and Vertical Look Location - Subject<br>vs. Velocity Cell Means . . . . . 54      |
| 11           | Visual Zone Percentages - Velocity and Traffic<br>Density Cell Means . . . . . 56            |
| 12           | Objects Viewed Percentages - Density vs. Velocity. . . 58                                    |
| 13           | Summary of Results . . . . . 62  |

5

LIST OF FIGURES

| <u>FIGURE</u> |  | <u>PAGE</u> |
|---------------|--|-------------|
| 1A            | Directions Requiring Operator Scanning vs.<br>Vehicle Type . . . . . | 8           |
| 1B            | Visual Activity Monitoring (VAM) System Helmet . . . . .             | 11          |
| 2             | Example of Simulated Fixation on Boat . . . . .                      | 12          |
| 3A            | Location of Face View Vidicon . . . . .                              | 14          |
| 3B            | Typical Face Camera Views . . . . .                                  | 15          |
| 4             | Block Diagram of Eye Movement System . . . . .                       | 16          |
| 5             | Century 22-foot Raven (before modification). . . . .                 | 17          |
| 6             | Experimental Boat (after modification) . . . . .                     | 18          |
| 7             | Layout of Experimental Boat . . . . .                                | 20          |
| 8A            | Location of Test Site . . . . .                                      | 23          |
| 8B            | Test Route Segments . . . . .  | 24          |
| 9             | Calibration Grid . . . . .   | 34          |
| 10            | Bow Marker Calibration Rods . . . . .                                | 35          |
| 11            | Peripheral Targets - Plan View . . . . .                             | 38          |
| 12            | Peripheral Targets Through Windshield . . . . .                      | 39          |
| 13            | TV Picture Sequence Each Second . . . . .                            | 41          |
| 14A           | Visual Zone Areas . . . . .  | 44          |
| 14B           | Distribution of Horizontal Looks - Low vs. High<br>Speed . . . . .   | 55          |
| 15            | Head Angle Mean % Time/Zone . . . . .                                | 61          |

6

## BACKGROUND

### INTRODUCTION

Researchers in the area of human factors have been primarily concerned with studying man in the automotive, aircraft and factory workplace environments, while little work has been aimed at the recreational activity of boating. Nevertheless, it was thought that it might be useful to attempt application of knowledge or techniques gained from experiments in these other environments to the boating arena. This was the primary thrust of the work done by Miller (1973) where he did extensive literature reviews within these other areas of human factors, suggested data and techniques that might be applicable to boating, and proposed future research needs.

These proposed future research needs included suggestions to perform experiments involving real boat operators as well as in-depth accident investigations to study the visibility related problems which might lead to collisions. Recently, such studies have been performed by Wyle Laboratories under Coast Guard sponsorship and have confirmed the apparent importance of visibility difficulties as a leading cause of collision accidents. Some of the Wyle results depended on response time and error rate measure obtained from a peripherally mounted response system mounted on an experimental boat (the VAST system). This would be considered as the utilization of a secondary task to measure behavior. The results from this type of experiment suggested that fatigue affected boaters' peripheral visual response times and visual response errors.

Another approach to studying the boaters' visual behavior is the one used in the present research. Operators were asked to perform normal boating tasks. Three cameras which are a part of the University of Michigan Visual Activity Monitoring System (VAM) were used to measure where the operator looks and what he looks at while performing the primary and only task of driving the boat. Making such determinations for two levels each of fatigue level, type of task, traffic density, and velocity were the objectives of the research discussed herein.

Since the ultimate goal will be to relate visual behavior to collisions, it is appropriate that the following section discuss some of the literature relevant to the collision and visibility problem.

#### LITERATURE RELEVANT TO COLLISION AND VISIBILITY

##### BAR Data and Wyle Studies

One of the major problem areas in boating is trying to determine factors that lead to collisions and accidents. An analysis of 1972 small craft accidents in the Miller (1973) report determined the following applicable statistics.

1. Of the 4308 vessels having damage, injuries or fatalities the following was reported:
  - a. 78% of the operators had 100 hours or more boating experience.
  - b. In 79% of the cases the weather and visibility were good.
  - c. In 56% of the cases, the water was calm, while only 24% of the cases reported the water condition as choppy.
  - d. In 63% of the cases, the wind was reported as none to light.

2. Of the 120 "Other Deaths," 45% of the vessels had a collision with another boat or an object.
3. Of the 3127 vessels damaged, 50% were cruising at the time of the accident, and 49% had a collision with another vessel.

These statistics lead one to suggest that it may not be the unskilled beginning boater who loses control of his vessel in rough water that causes the majority of accidents; but rather, it is the experienced operator cruising in other than rough water who collides with another object which he either 1) did not see in time to avoid, 2) did not recognize as being on a collision course with him, or 3) did not know how to avoid with his particular skill, knowledge, or experience level. The data used to arrive at these conclusions were the coded Boating Accident Reports which are used to develop the CG-357 report. These BAR's usually did not have sufficient details to establish conclusive causal factors and numerous coding errors were found in the BAR's as they were analyzed for the Miller (1973) research. Nevertheless, collisions appeared to be a significant issue and making initial postulations as to the human factors implications brought focus to the problem.

As a result of this initial focus on the collision problem, the next follow-on study by MacNeill and others (1975) attempted to further identify causal factors in collision accidents in accord to some of the recommendations made in the Miller (1973) report. One conclusion in the MacNeill report was that "...the frequency rate of the collision type accident may be more than 19 times as great as the frequency rate reported in CG-357." (pg. 35). Therefore, the importance of performing

9

collision related research seems to be even greater than it was expressed to be as in the Miller (1973) report which was based on CG-357 data.

In summarizing another phase of their work, MacNeill (1975, pg. 71) points out that "inattention" probably accounts for 22% of the probable collision causes. This inattention can be interpreted as the operator's failing to process and/or act on the visual information which should have been used to avoid the collision.

As a result of ten in-depth investigations involving 15 boats MacNeill, in his next report, followed up this "inattention" suggestion and found that:

"Visibility oriented problems were identified as causing the collision in 94% of the cases" broken down as follows: (MacNeill and Cohen, 1976, pg. 9)

|  |       |
|--|-------|
| -- he didn't see boat/object in time to avoid it | 34%   |
| -- he didn't see boat/object at all because:     |       |
| * he wasn't looking                              | 27%   |
| * his vision was obscured                        | 20%   |
| * it wasn't visible                              | 13%   |
|  | <hr/> |
|  | 94%   |

In the latest series of studies under Coast Guard sponsorship MacNeill, et al. (1976) discusses the complete series of three tests using a Visual Alertness Stressor Test (VAST) system. A primary function of this system was to test fatigue effects on peripheral vision response times using an instrumented boat and operators who would be subjected to fatigue profiles typical of normal boating activity. The original idea for the VAST experiment and fatigue

profiles was conceived by J. Miller while acting as a consultant to Wyle Laboratories. The engineers at Wyle then refined the concept and implemented it in the form of the present VAST boat. The reported results of the VAST-1 tests for six subjects indicated that the fatigued conditions resulted in significantly more missed signals and slower response times. (MacNeill, et al., 1976, p. 19.)

Similarly, in the VAST-2 study, with eight subjects, response times were slower under the fatigued condition; however, there was an interaction with an alcohol factor which makes the results regarding fatigue less certain. Error rates were not reported.

The VAST-3 effort attempted to study "alcohol, fatigue, noise, shock/vibration, glare and their interactions in a three subject experiment. These were thought to be the major potential stressors in boating. The results yielded no single factor which consistently degraded error rate or response times. Alcohol was statistically significant as a main effect on response time performance, but it "improved" response time performance at the middle .05% level. (This is not an unusual research finding with respect to alcohol effects.) The fatigue-alcohol and glare-noise/shock/vibration interactions were statistically significant for the error data. This ambitious effort while not yielding clear and certain results, (possibly because of sample sizes) provides a good beginning to exploring the effects of some additional relevant stressors on the boat operator (besides alcohol and fatigue).

These Wyle studies while informative, were not expected to be conclusive. Any new research arena must usually be approached from

several directions and in repeated studies before conclusions can safely be made with a reasonable degree of confidence.

Additional insight into the boater's visual behavior might be gained by relating vision research done with respect to the automobile driver. This may be particularly relevant since boat drivers are almost always automobile drivers.

#### The Automobile vs. Boat Operator

Due to the cockpit similarities, and since adult boat operators are also experienced automobile drivers, one might expect that a large portion of a boat operator's behavior may result from a "transfer of training" from automobile driving. This may be unfortunate, since there are other differences between the two environments which an operator should compensate for when driving a boat.

Differences between these two types of operations become apparent when one considers the primary tasks. The automobile driver must be primarily concerned with the lateral placement of the vehicle on the roadway (tracking). However, the boat operator and aircraft pilot have more flexibility in the navigation of their vehicles, and thus, tracking is not the primary task.

Collision avoidance should be the primary task for the boater. This is necessitated by the fact that many potential non-vehicular collision objects (i.e., logs or debris) are difficult to see in the water. This is not to say that the automobile driver is not concerned with similar collision avoidance, but given that he stays in his limited tracking area, the

probability is lower that a potential non-vehicular collision object will be in his path and he tends not to expect them, (such as "pot" holes on normally smooth highways).

The automobile driver in his search or scanning behavior is aided by a mirror system which has limited availability and usefulness for most boaters. Furthermore, the automobile driver need only search primarily for vehicles in limited areas, namely, forward, directly to the rear and  $90^\circ$  to the sides. In contrast, the boater should search for vehicles coming from the total  $360^\circ$  surface area surrounding his vessel. Thus, the dispersion of the visual search pattern should be greater for the boater than the automobile driver. These differences in direction from which potential collision objects might come are illustrated in Figure 1A for the boat vs. car vs. airplane.

The prime task of both the boater and the automobile driver requires primarily scanning to the front, but for different reasons. The driver, as previously mentioned, is concerned with tracking, and the boater is concerned with obstacle avoidance.

Data has shown, for example, that over 90% of the visual information searched for and used in auto driving comes from a small area about 150 ft. ahead. This and other eye movement type findings for automobiles can be found in Kaluger (1970), Mourant (1972), Whalen (1968) and Zell (1969). This behavior characteristic, if subconsciously transferred to boat driving, would mean that the operator would pay minimal attention to any peripherally located targets. Such visual search characteristics required in auto driving could lead to potential causes of collisions

13

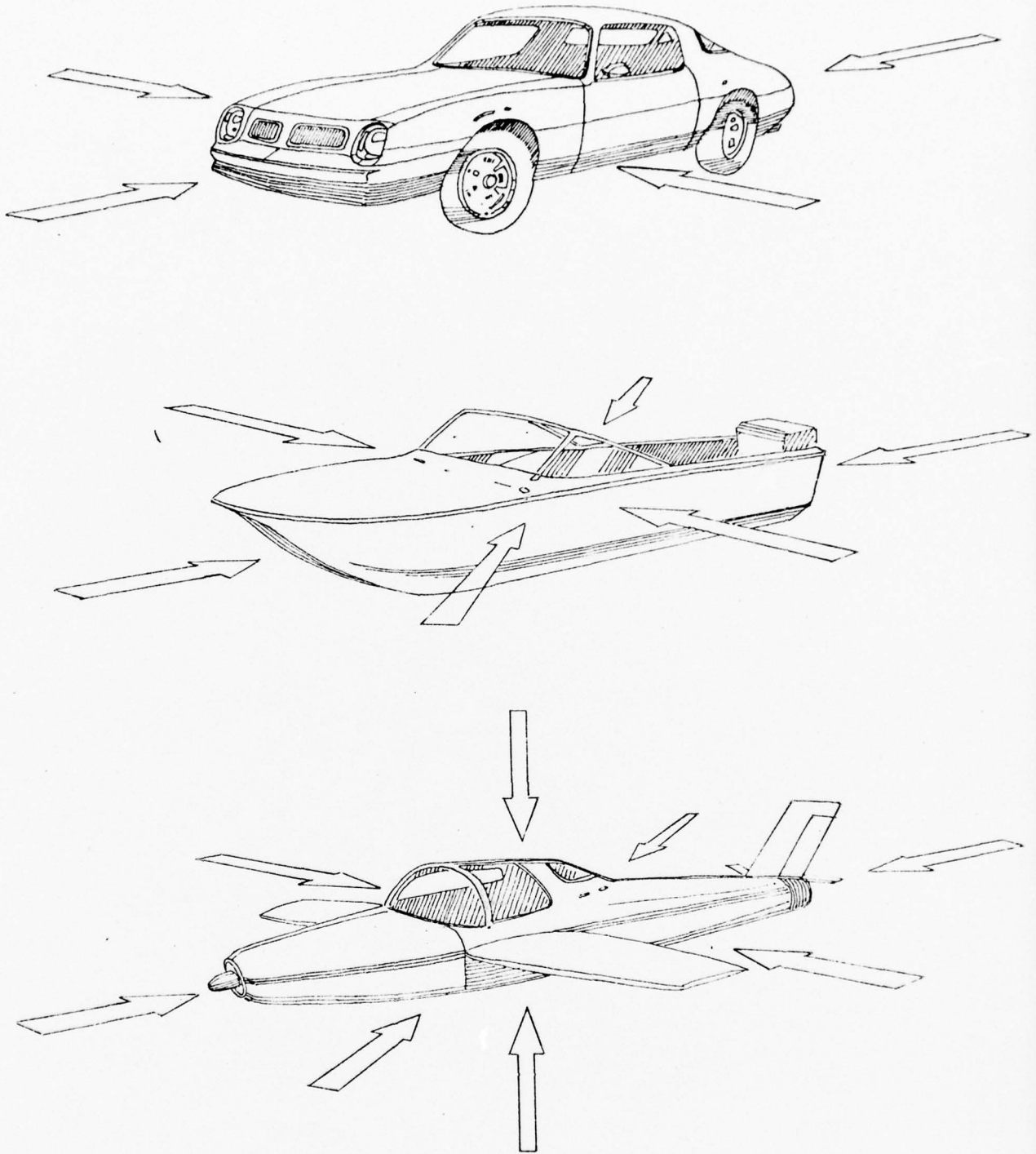

Figure 1A: Directions Requiring Operator Scanning vs. Vehicle Type

14

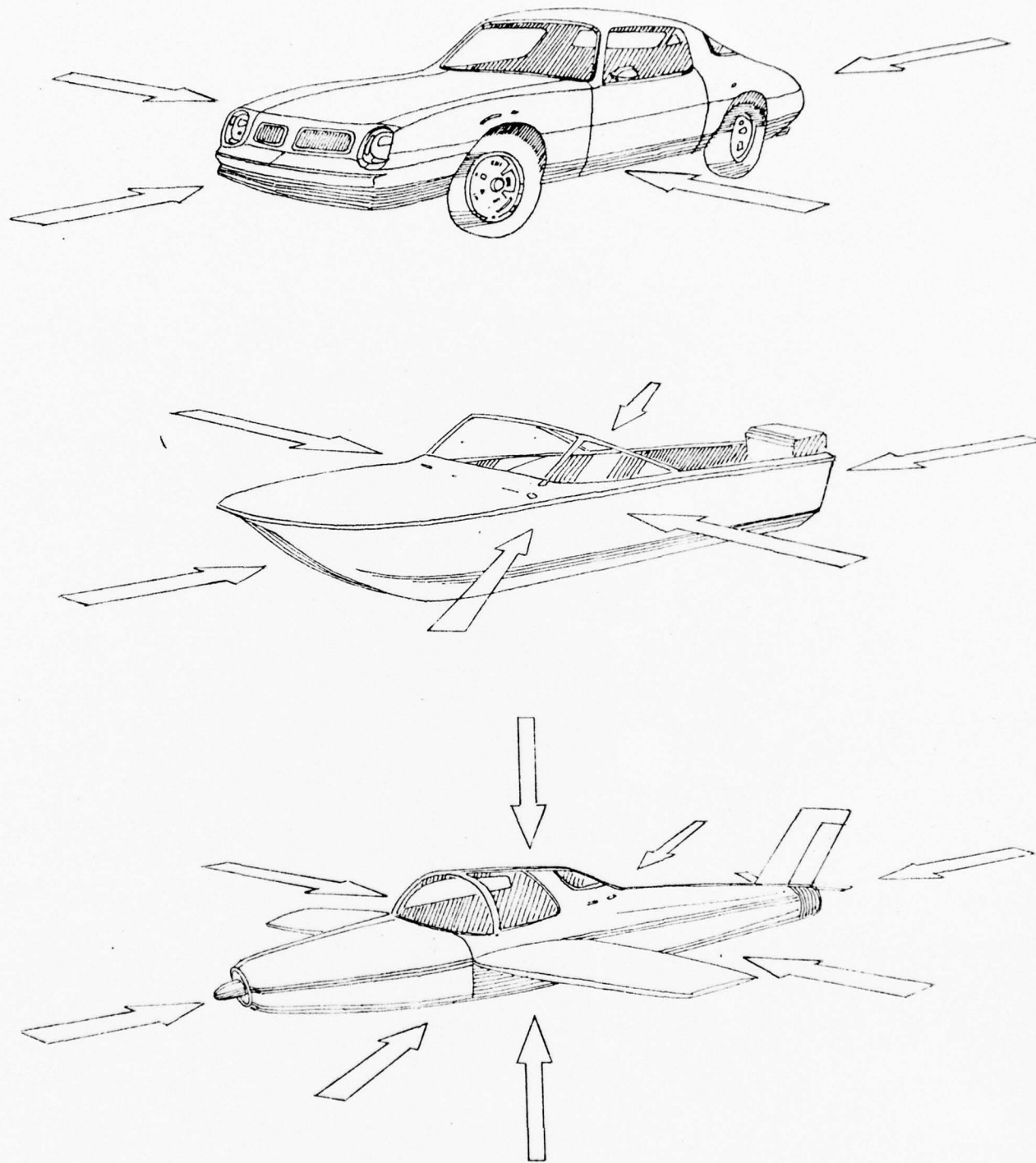

Figure 1A: Directions Requiring Operator Scanning vs. Vehicle Type

14

in boating. Therefore, one would certainly be interested in determining the visual search patterns used by the boat operator to see if such patterns might be heavily biased by extensive automobile driving experiences.

Another characteristic is that it is not necessary for the boater to monitor his displays as frequently as the automobile driver. An example of this is that the automobile driver must obey speed limits where the boater usually is not restricted to speed. Thus, one would not expect the boater to fixate often on his instruments unless specifically required to do so by the task.

Fixation duration may also be affected by the perceptual problems a boater may encounter on the water. Gordon and Michaels (1965) indicate that automobile drivers are aided by the roadway in front of the vehicle in making distance judgments to other objects. Unfortunately, the boater normally does not have a readily available scaling aid such as a road or constant path. Determining the distance to an approaching possible collision vessel may be difficult for the boater depending on the background and environmental conditions.

Various researchers, such as McDowell (1975) have recorded a significant effect of vehicle velocity on eye movements and suggested that this is related to the operator's information processing. Velocity effects may be particularly pertinent in boating due to the fact that the operator's speed is not regulated and he has the freedom to select a speed in most types of boating environments.

With respect to fatigue, a previous study of the eye movements of sleep deprived automotive drivers' by Kaluger and Smith (1970)

indicated that eye movement patterns were less concentrated and that the fatigued drivers possibly had to use foveal vision in areas typically monitored peripherally. Using these measures and others, they showed that fatigue significantly alters eye movement patterns.

From the previous literature it can be speculated that collisions might be related in part to the visual habits automobile drivers bring to the boating task. The exploration of this possibility, the determination of the basic looking characteristics of boat operators, and the investigation of the effects of fatigue and type of boating task on these characteristics are the specific issues which this research addresses.

## METHODOLOGY

### EQUIPMENT

#### Visual Activity Monitoring (VAM) System

The essential component of the visual data collection system is the VAM system. This system consists of two television vidicon tubes attached to a helmet which is worn by the subject and stabilized by side brackets and a bite bar (see Figure 1B). One vidicon is forward viewing, thus recording the information in the direction the subject is looking. The second vidicon is equipped with special optics and a miniature light to pick up a corneal reflection from one eye which translates into eye movements. The VAM system through its mechanical and electrical adjustments allows the eye spot camera to be superimposed on the field of view of the other camera, producing a small white dot, which when calibrated identifies where the subject is actually looking within about 1/2 degree (see Figure 2). The helmet system including vidicons weighs approximately 1.65 Kg.

10

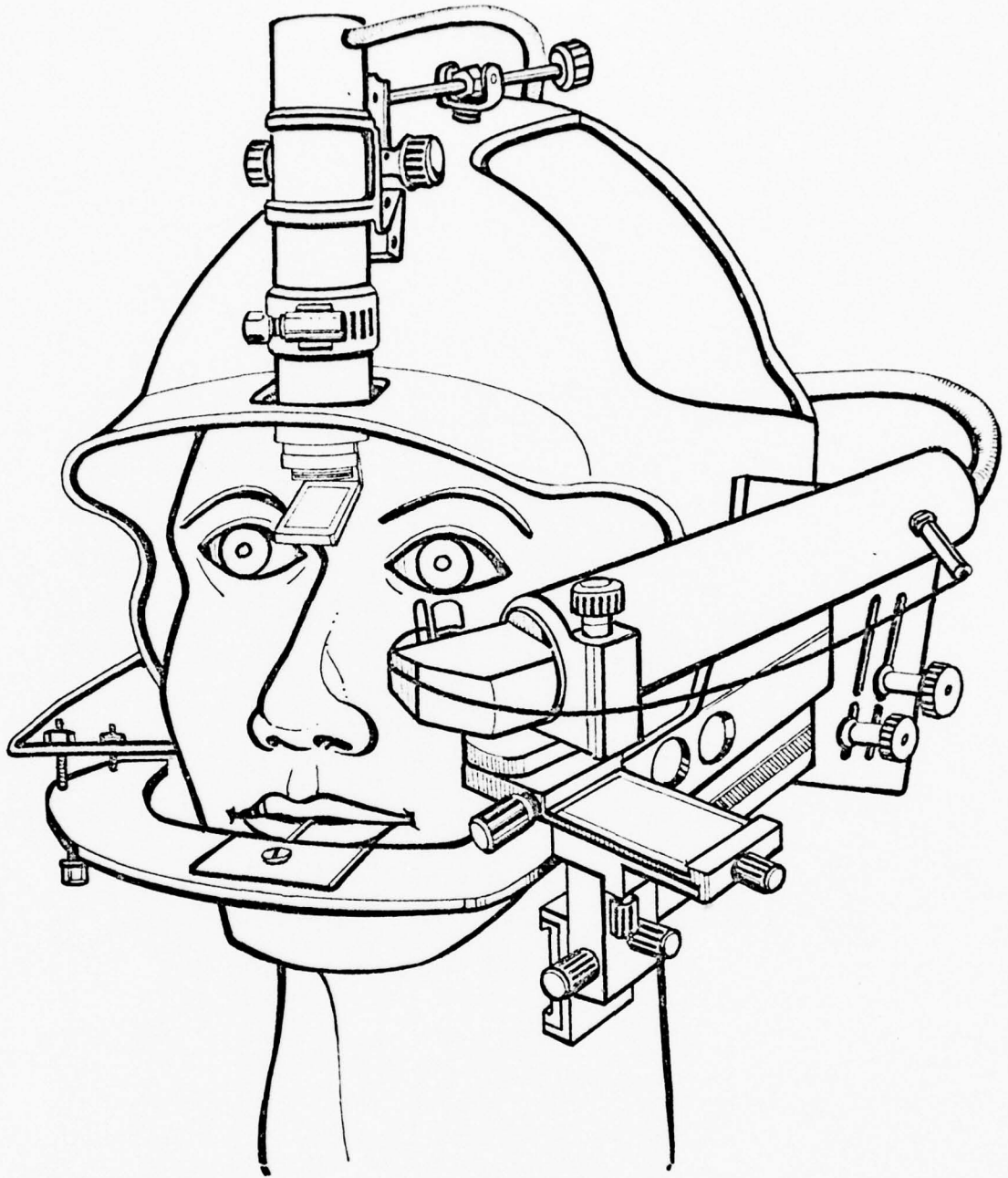

Figure 1B: Visual Activity Monitoring (VAM) System Helmet

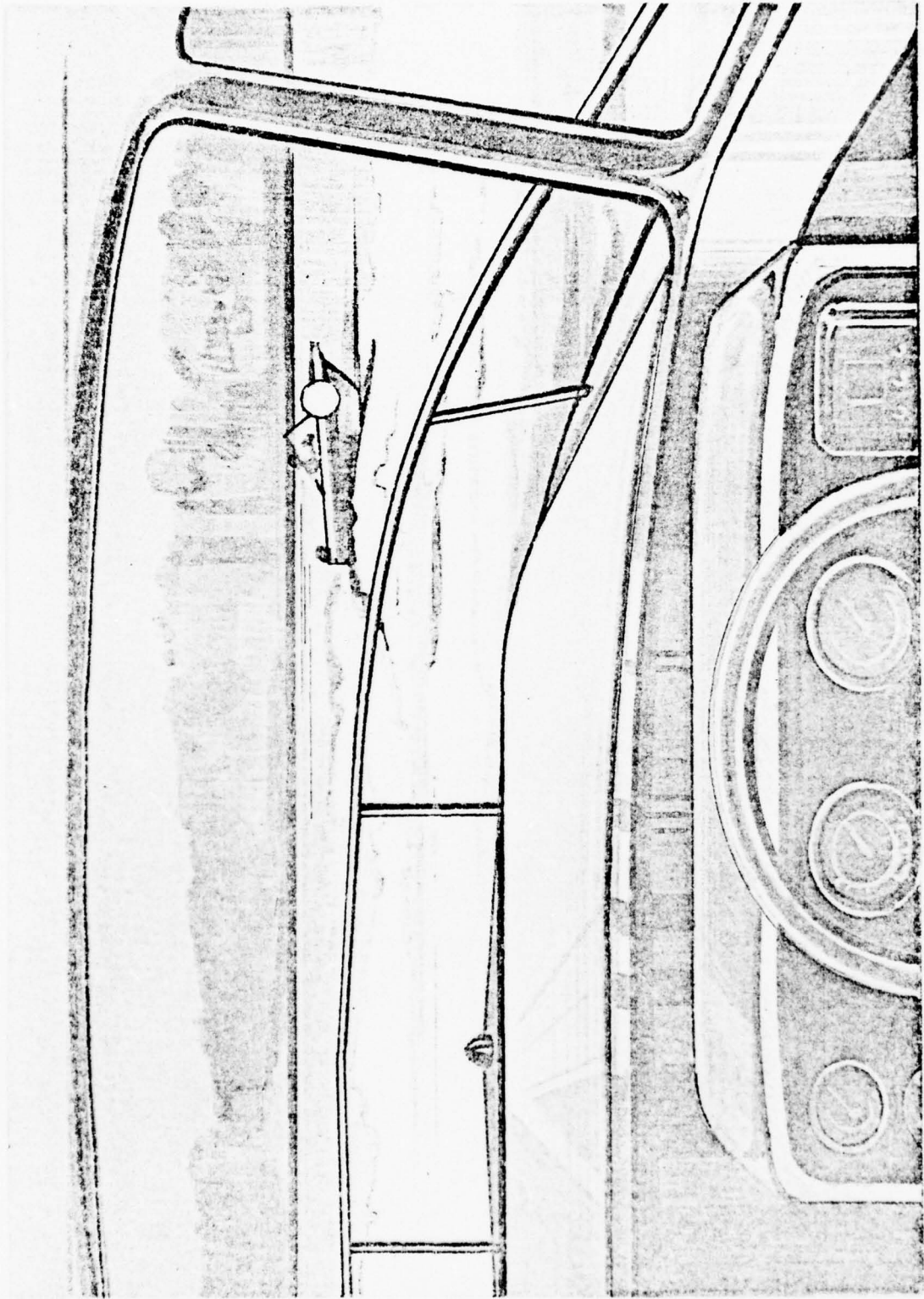

Figure 2: Example of Simulated Eye Fixation on Boat

Also part of the system is a third vidicon mounted in the instrument panel and aimed at the subject's head. Figure 3A shows the location of this face view camera on the dash board. This camera records primarily head movements and can be used with or without the helmet system. It produces a view as in Figure 3B.

When all three vidicons are operated, the electronics of the VAM system (Figure 4) record sequentially from each separate channel at an arbitrarily determined rate of four sequences per second. Thus, each camera is viewed for one quarter of a second then switched to the next camera in the following order: eye camera, field camera, eye camera, face camera. Any camera can also be operated separately, giving continuous recordings on that channel.

#### Boat

The boat which was used for this study was a 1975 Century Raven, a 22-foot, inboard-outboard with hard top and small cutty cabin. This boat is shown in Figure 5, as received from the manufacturer. It was a gift to the University of Michigan donated to assist these researchers in conducting various boating safety research projects. The particular model was chosen for four reasons. 1) It was the minimum size considered to be safe for data collection operations in water conditions which the typical boater might face. 2) Up to five people would be necessary during certain types of data collection, and this boat was sufficient to provide safe transportation for that number. 3) The forward located starboard helm position causes

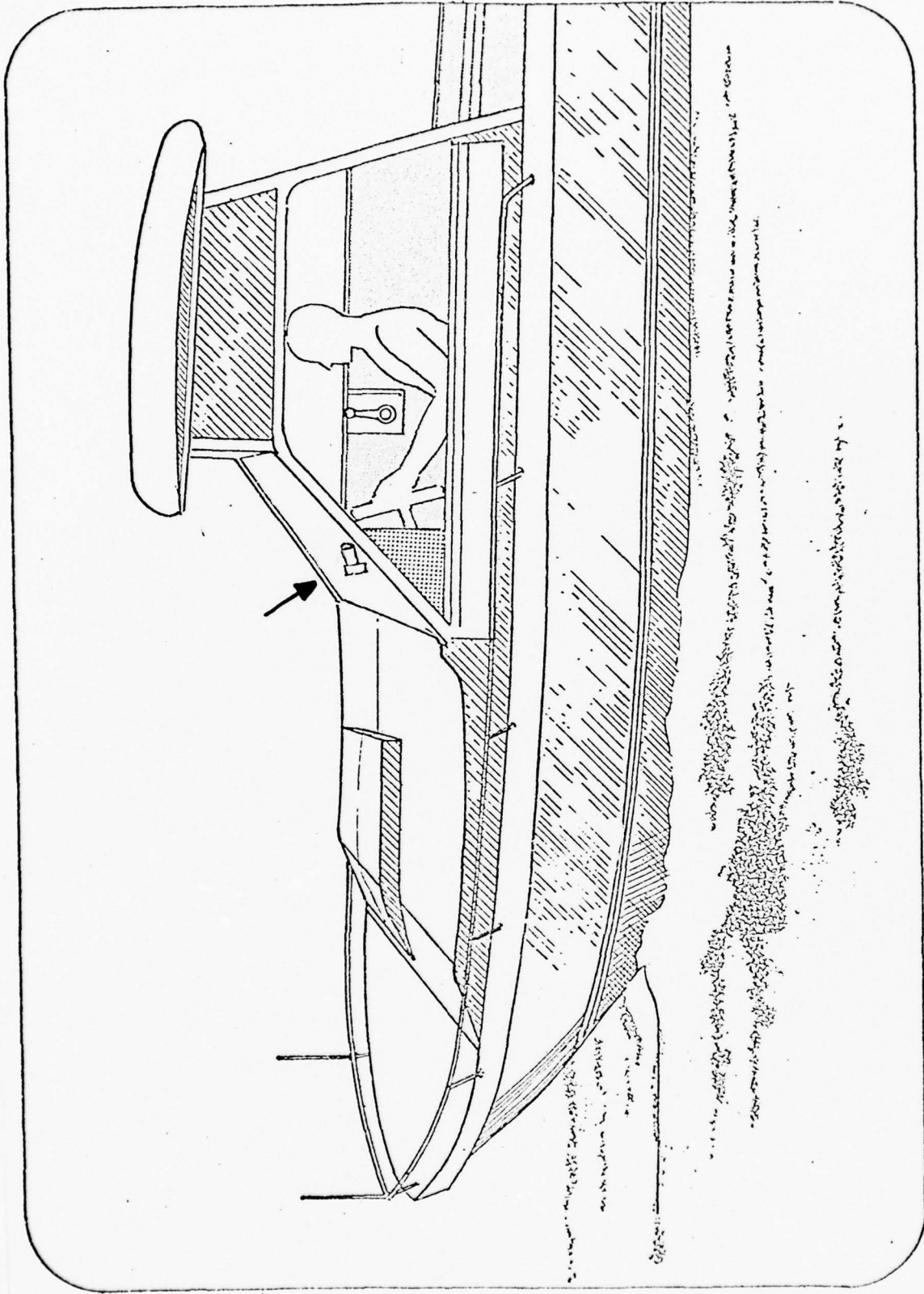

Figure 3A: Location of Face View Vidicon.



Without Helmet (Head Angle 10°)



With Helmet (Head Angle 10°)

Figure 3B: Typical Face Camera Views.

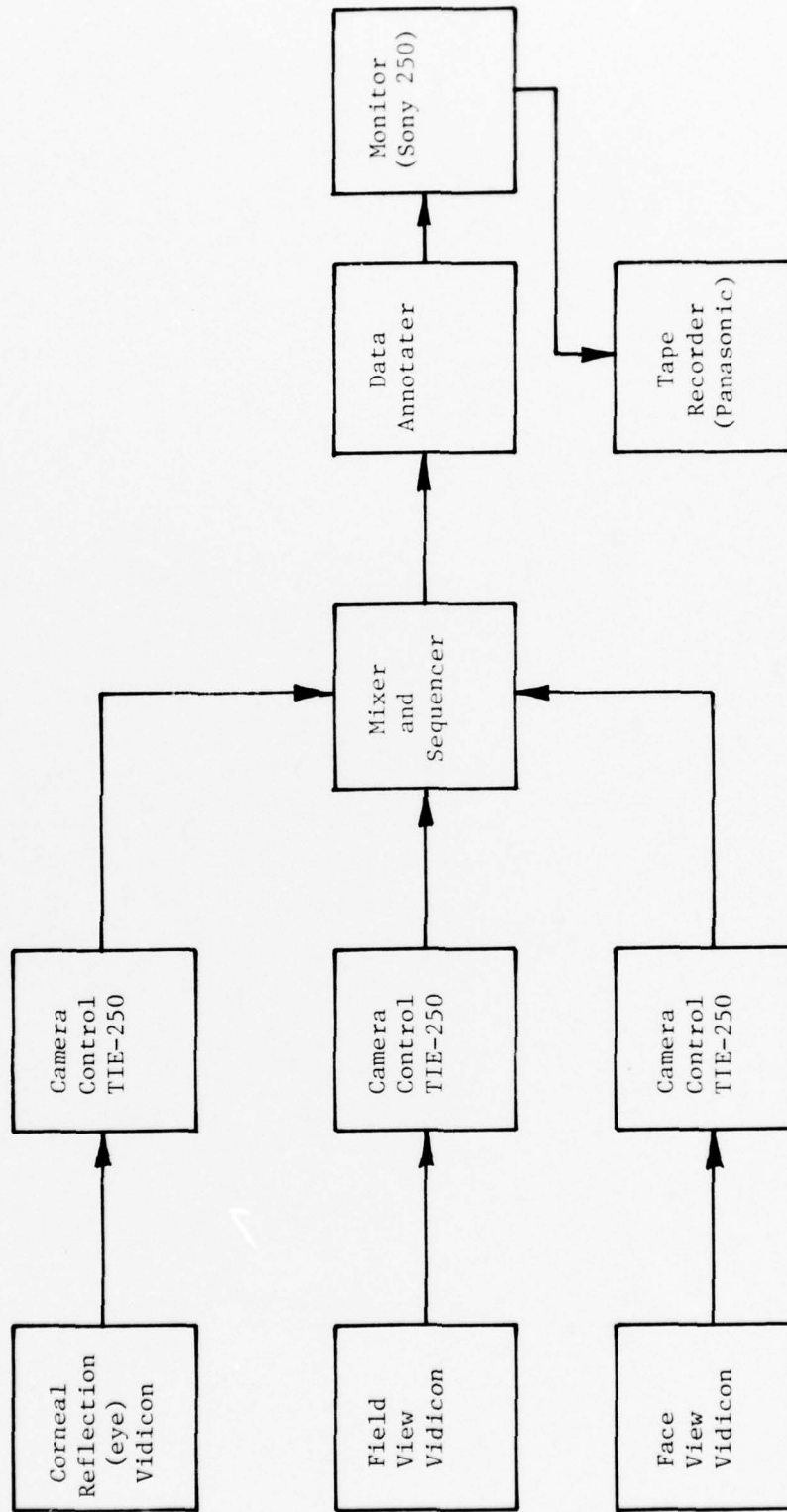

Figure 4: Block Diagram of Eye Movement System.



Figure 5: Century 22-foot Raven (before modification)

the visibility and control of the boat to be quite similar to popular 16 to 24 foot boats with similar helm positions. 4) The hard top, enclosed cockpit area provided protection of the VAM system from blowing water and also shielded the operator and TV vidicons from excessive sunlight levels.

In spite of the advantages this boat offered for the team's vision related research, it was felt that additional modifications were necessary to improve the probability of gathering good data. Modifications included installation of glare reducing materials on reflective surfaces, redesign of the instrument panel gauge locations, elimination of the front vented windshield by substitution of a single pane of glass, and raising the hard top by 15 inches to allow sufficient clearance for the VAM helmet. This latter modification

permitted standing capabilities under the roof and installation of a forward viewing 35 mm wide-angle camera. The boat in its modified form is shown in Figure 6. In its modified form, the boat proved to be very functional in successfully meeting the expectations of the researchers during actual data collection.



Figure 6: Experimental Boat (after modification).

### Layout of Experimental Boat

There were four work stations existing during data collection efforts. In the starboard helm seat of course was the subject, in the seat left of the subject was Researcher #1 who instructed the subject and verbally recorded notable visual events during the test runs. Behind the subject was located the primary electronic package of the VAM system and Researcher #2 who was in charge of monitoring and recording the events picked up on the three vidicons. To the left of Researcher #2 was Researcher #3 whose task was to count and record traffic density and movements and take selected 35 mm photographs along the test route. The location and layout of the various researchers and data collection equipment are shown in Figure 7.

## EXPERIMENTAL DESIGN

### Independent Variables

The independent variables of the experiment were of two types: controlled and measured. The controlled variables included: subjects, velocity, fatigue and task-route. The measured variables were: traffic density and environmental conditions.

### Controlled Variables

Subjects. Subjects obtained for the study were initially solicited through a newspaper advertisement in the local cities near the testing area. From over 30 responses, four subjects were selected who could be available for the duration of the study and who met the following criteria: 1) 20/20 uncorrected vision with normal color and depth

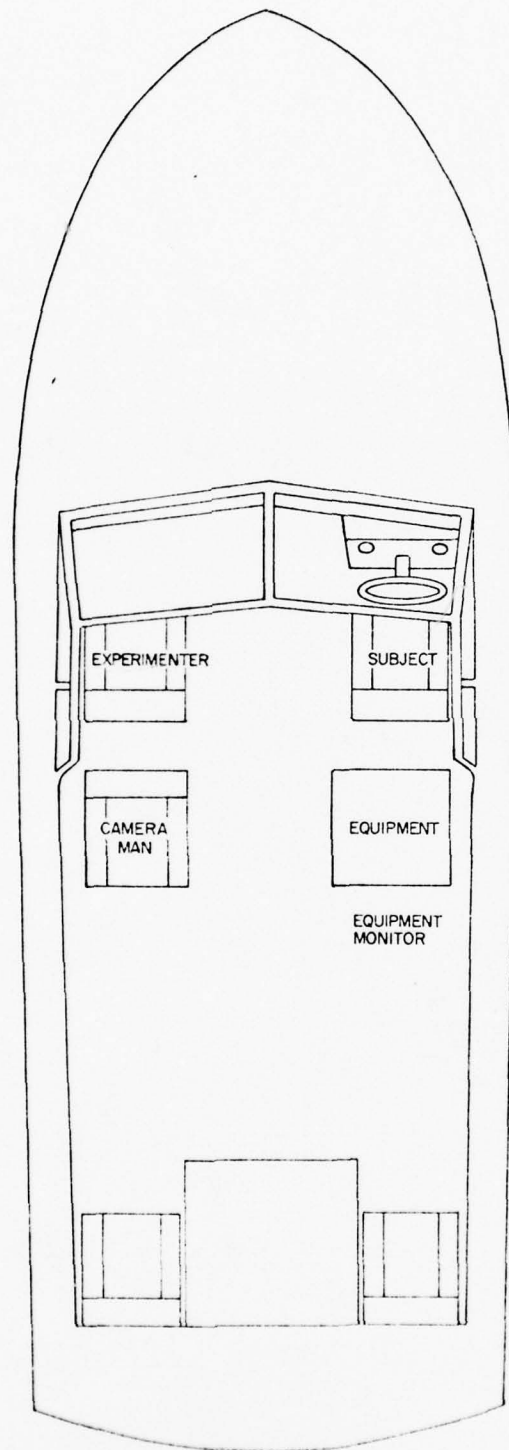

Figure 7: Layout of Experimental Boat

perception, 2) extensive boating experience within the general test area using steering wheel controlled power boats, 3) natural teeth (without dentures). The four subjects were young males between 21 and 28 years of age. The specific types of physical and experience information solicited from the subjects to judge these criteria are given in Appendix A.

Fatigue. The contract work statement called for two levels of fatigue with the second level coming after several hours of normal activities typical to boating. These researchers chose to use a three-hour fatiguing period between data collected on Run #1, the low fatigue level, and Run #3, the high fatigue level. These three hours would approximate the fatigue activity used by Wyle Laboratory. Also, to further match what Wyle called the "Family Profile", the fatiguing activity of driving the boat for an approximate 45 minutes additional time was included in the 3-hour period between Runs #1 and #3.

Low fatigue level then was a collection of data from Run #1 which occurred within one and 1/2 hours of the time the subject arrived on the test site, followed by three hours of "fatiguing" activity, followed by Run #3 which occurred during the fifth hour of the subject's being on the test site.

Tasks and Route. The selection of the task and route were based primarily on the desire to choose conditions of low density and medium density traffic and to satisfy the "maneuvering" and "cruising" types of tasks called for in the work statement. However, not being able to control the density variable, a number of similar navigation task segments were chosen hoping that the desired densities would be encountered. The specific geographical area of the test was in

Southeastern Michigan among the islands and lake-like bays of the lower Detroit River as it opens into Lake Erie (Figure 8A). The area seemed ideal in which to conduct such studies since inland lakes, coastal water, river, and large water body type conditions can all be found within close proximity. These waters along with the specific test route chosen are shown in Figure 8B. Table 1A indicates the various segments of the route, as numbered on Figure 8B, and the general type of task performed on each of these segments. Regarding the traffic encountered, it was suggested earlier that low and high density traffic conditions were desired but since these were not controllable, it had to be measured to see if, in fact, the target traffic density levels were met by the chosen routes. These were measured during the data collection runs to provide guidelines as to which segments satisfied the contract's task (density) requirements.

Speed. Two speeds were arbitrarily selected as representative of typical "cruising" versus "maneuvering" types of operations. The "maneuvering speed" was fixed at 6 miles per hour (or 1400 RPM) and the cruising speed was fixed at 25 mph or (3300 RPM). Maintaining these speeds was to some extent a type of secondary task. Both of these speeds were used in both high and low traffic density situations.

#### Measured Variables

Traffic Density. The traffic densities were interpreted as being those boats within the operator's forward 1/4 to 1/2 mile field of view, as represented by approximately 100° to the left or right from the driver's straight-ahead viewing. This would be the traffic which might in some way bear upon the driver's visual response behavior.

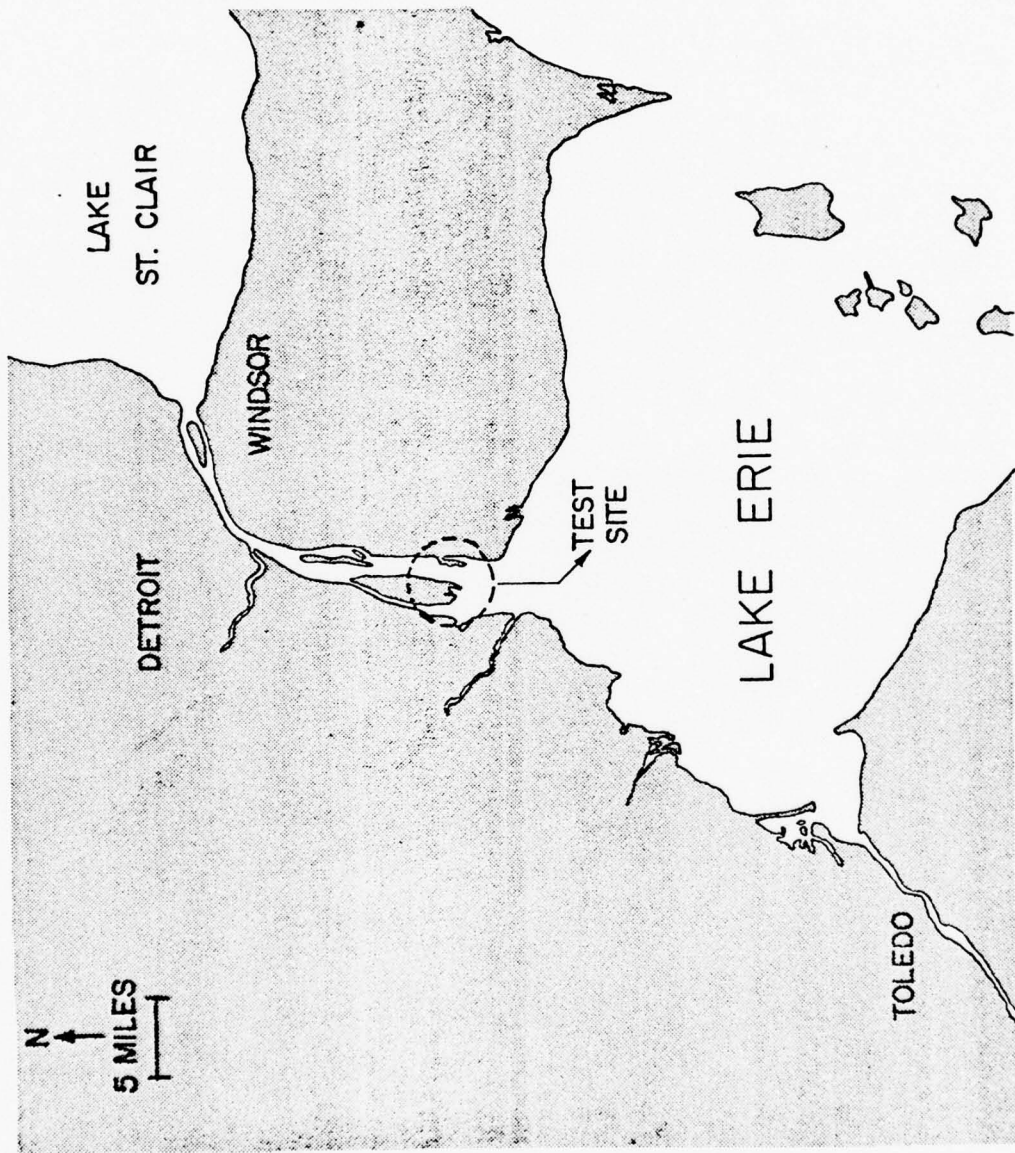

Figure 8A: Location of Test Site.

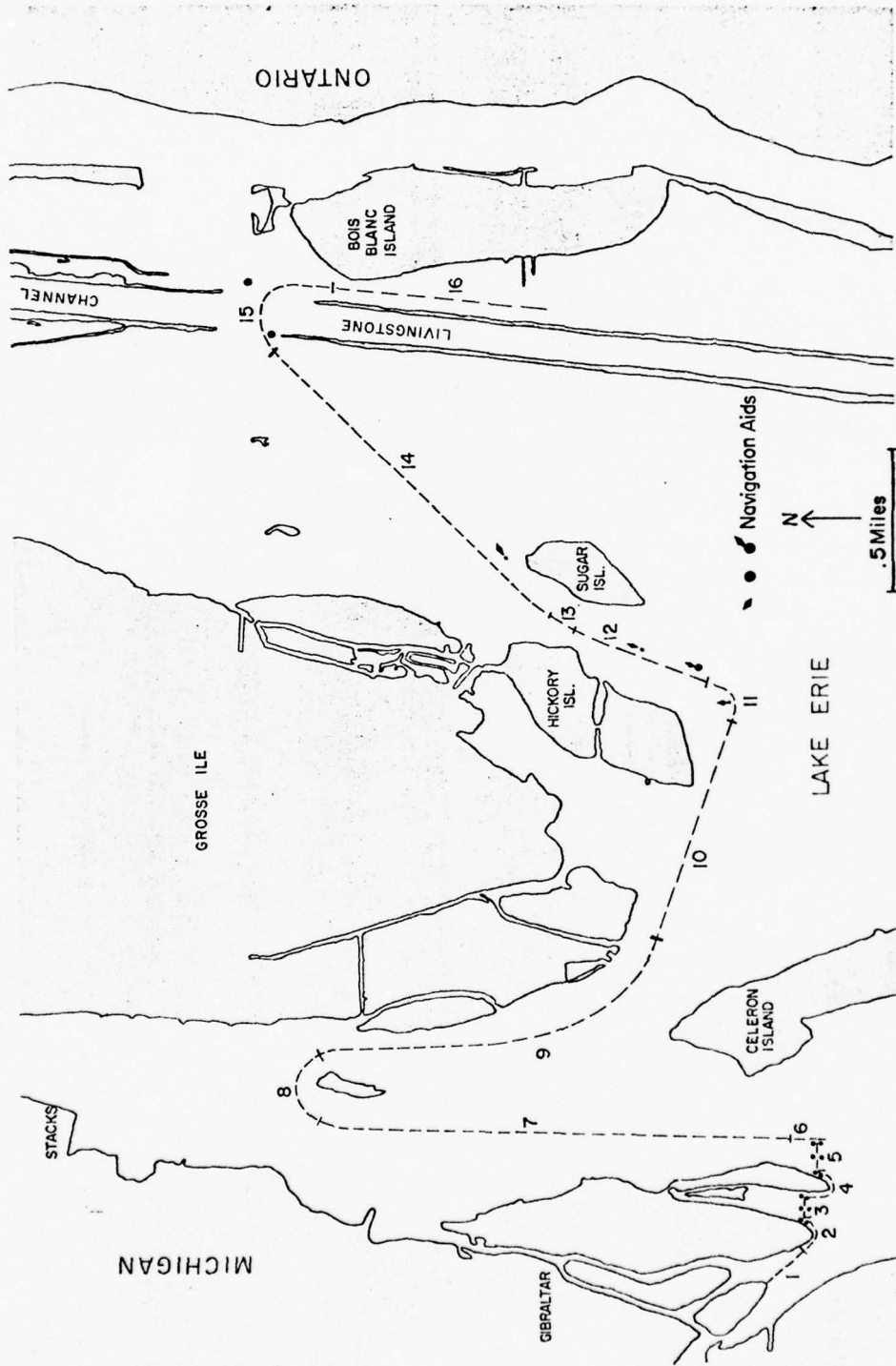

Figure 8B: Test Route Segments.

Table 1A: Route Segments and Navigation Task.

| Segment # | Navigation Task                   |
|-----------|-----------------------------------|
| *1        | Heading to Visual Reference Point |
| 2         | Following Left Land Contour       |
| *3        | Centering in Buoyed Channel       |
| 4         | Following Left Land Contour       |
| *5        | Centering in Buoyed Channel       |
| 6         | Left Tight Turn (90°)             |
| *7        | Heading to Visual Reference Point |
| 8         | Right Wide Turn                   |
| 9         | Following Left Land Contour       |
| 10        | Heading to Visual Reference Point |
| 11        | Left Tight Turn (90°)             |
| *12       | Centering in Land Bound Channel   |
| 13        | Right Wide Turn (45°)             |
| 14        | Heading to Visual Reference Point |
| 15        | Maneuvering through Intersection  |
| *16       | Centering in Land Bound Channel   |

\* Indicates those segments chosen for analysis in fulfillment of the contract's task and density requirements.

The specific traffic which might be most relevant to the operator's responses might be that traffic which is moving (as opposed to anchored); thus, it was noted whether the other boats were: anchored (left or right), passing or being passed, crossing, and moving in the same or the opposite direction as the test boat. All of these categories were included within the traffic movement counts made on each segment of the test route for the purpose of determining which segments would satisfy the density requirements.

Environmental. The environmental variables were characteristic of southern

Michigan August weather, and probably characteristic of a lot of summer boating weather. (Partly cloudy to sunny, 75° to 85° F., winds 10 mph, relative humidity 65%, visibility 5-10 miles). Recording these environmental variables was done both by observation of the conditions at the test site and by telephoning the U.S. Weather Bureau to obtain the hourly reports of environmental conditions occurring at the time of each test. They varied very little during the entire data collection effort.

#### Visual Behavior Measures

As suggested earlier, the visual behavior questions of concern are: 1) where does the boat operator look, and 2) what does he choose to look at with the time available?

The first question is primarily spatial in nature. The data was analyzed to determine, for a given task and fatigue, the percent of time the subject spent looking in the various directions (degrees) around the boat, both below and above the horizon, and within and outside the cockpit.

The second question was answered by coding the data to reflect the "objects" being viewed and the percent of time spent viewing these various "objects." The object categories include such things as: scanning water; scanning land; and looking at moving boats, anchored boats, freighters, navigation aids, tachometer, compass, or speedometer.

A final type of measurement of visual behavior was the duration of fixations. It is this author's opinion that fixation duration while used extensively in other eye movement research is not as important as the variables above in an initial study such as this. Hence, it is not

of primary concern as a response variable in this study. Nevertheless, some duration data will be given in the results section.

Summary of Experimental Design

The following matrix (Table 1B) illustrates the experimental design as discussed in the previous sections. The segments of the test route which satisfy the experimental conditions are shown within the cells and are described in Table 1A, pg. 25.

Table 1B: The Experimental Design Matrix.

|                  |      | Type of Task   |                 |   |                 |
|------------------|------|--|-----------------|---|-----------------|
|                  |      | Maneuvering in Traffic<br>(At least 6 moving<br>boats within 1/2 mile) |                 | Cruising in Open<br>Water (No more<br>than 1 Boat within<br>1/4 mile) |                 |
|                  |      | 6 m.p.h.   |                 | 25 m.p.h.   |                 |
|                  |      | Low<br>Density   | High<br>Density | Low<br>Density  | High<br>Density |
| Level of Fatigue | High | Segments<br>#1-3-5   | Segment<br>#16  | Segment<br>#7   | Segment<br>#12  |
|                  | Low  | Segments<br>#1-3-5   | Segment<br>#16  | Segment<br>#7   | Segment<br>#12  |

The test route segments shown, then, represent the eight different test conditions. Identical types of data concerning the subjects' visual behavior was collected as the boat was driven through each of the segments which represent these eight test conditions. Then, the resultant data was compared using statistical tests to determine differences in the boat operators' visual behavior as a function of the type of test condition. Details concerning how the data was collected and analyzed appear in the following sections.

TEST PROCEDUREPre-Testing and Preparation of SubjectsSubject Consent

During the subject's first visit to the base facilities, he was familiarized with the boat and controls, viewed a video tape explaining the boating study and signed a consent form before proceeding with the other activities of the study.

In previewing the test boat, subjects were permitted to enter the boat and sit in the driver's seat and were shown the various instrument panel displays and controls. This included showing the subjects how to operate the single lever throttle gear shift and what function each of the various switches on the instrument panel performed. All of the subjects seemed to be generally familiar with the type of instrumentation and controls on the boat.

After previewing the boat, the subjects viewed a video tape which showed the type of data which was to be collected, what the helmet system looked like while on a subject, and how the bite bar and foam liner would be constructed. They were also told that it would involve approximately 20 hours of work spread over several days and they would be paid \$5 an hour. After this further 30 minute introduction, a subject was then asked if he was willing to participate in the study. If the subject was still interested in participating, he was given a consent form which he read, which was explained to him, and then which he signed.

#### Physical and Experience Data

The subjects were then asked to write down additional information detailing their boating experience. This information is contained in Appendix A.

Vision tests were given which measured their acuity, color, aphoria and depth perception. Anthropometric dimensions of the subjects which would be relevant for seat adjustments and fitting the helmet were subsequently taken. These dimensions also appear in Appendix A.

#### Helmet and Bite-Bar Fabrication

The helmet of the Visual Activity Monitoring System must remain stable on the subject's head in order for the system to remain in calibration. To accomplish this stabilization, a custom-fit bite-bar and foam helmet liner were fabricated for each subject. The bite-bar was made from dental impression wax and aluminum. The foam interliner for the helmet was constructed from pressurized urethane ingredients which harden in approximately three minutes after mixing.

#### Boat and Route Familiarization

After completing the bite-bar and helmet liner fabrication, the researchers took a subject for his first familiarization run to acquaint him with the operative handling of the boat and the visual land marks in the test area. One of the researchers again explained the functions of each of the controls and displays to the subject, went through the engine starting checklist, started the boat and maneuvered it away from the dock area. Once the boat was through

the residential channel and away from other traffic, the subject was permitted to take over operation of the boat. The subject was instructed to drive the boat through a course similar to the exact test route used later. During this run, specific landmarks and navigation aids were pointed out since they would be later used to direct the subject through the actual test run. Key landmarks included such points as: Celeron Island, Edison Stacks, Calf Island, Ford Yacht Club, Hickory Island, Black Can Buoy #16, Fox Island, Lights #19 and #20, Livingstone Channel and Bob-Lo Island. On future familiarization runs the subjects would be asked to point out these landmarks. This was to reassure the researchers that when instructions were given to them regarding where to drive the boat, they would know the meaning of these instructions without further elaboration. In this familiarization run, subjects were given instructions to make turns with the boat, to change speed by variations in RPM, and to proceed according to specific compass headings. As these maneuvers were performed, two of the researchers subjectively evaluated the boater's skill on a scale from 1 to 10, by making judgments about certain boating situations and handling the boat. A number 5 would represent an average boater, a number 10, the most skilled professional type driver. All subjects in this study seemed to perform, in the researchers' judgments, at about the 5 to 7 range, thus being average to slightly above average. The most notable indications of lack of skill among these subjects seemed to be, 1) failure to consider wind and water conditions when docking, 2) docking with excessive speed, 3) unfamiliarity in piloting by compass and 4) failure to utilize outboard drive angle information when maneuvering the boat.

With respect to route familiarization, this first trip of approximately one hour was insufficient for subjects to immediately identify key landmarks. Therefore, this landmark acquaintance was completed in subsequent familiarization runs.

#### Practice Wearing VAM Helmet

For the second and third familiarization runs, which were on separate days, the subject was fitted with the entire VAM system and a corneal eye spot reflection was obtained so the helmet settings could be indexed for each subject. This initial setup was performed within the test room, and after its completion the subject and helmet system were taken aboard the boat. Once aboard, the helmet was placed back on the subject fully tightened and stabilized. One of the researchers started the boat and drove it away from the dock area. The subject was then permitted to take over the controls for the remainder of the run. During runs two and three the subject maneuvered through the approximate test route in accordance to verbal instructions which used landmark nomenclature. By the end of the third 1-hour run, the subject seemed to be performing normally with the helmet and were familiar with the critical landmarks. The subject was then scheduled for an approximate 6-hour time slot in the next few days which would then be his data collection session. This third day's activity will now be described in the following "Test Phase" section.

#### Test Phase

##### Face Camera and Seat Adjustments

Upon arrival the subject proceeded to the boat where he was permitted to adjust the seat to a comfortable position. The subject

was then asked to simulate his driving position, and the instrument panel mounted face camera was adjusted so as to encompass the subject's head along with anticipated head turns and movements. This face camera and seat adjustment was done before the helmet was placed on the subject's head to conserve the time that the subject would actually be wearing the full helmet apparatus. (Experience has shown that the VAM system becomes uncomfortable to subjects after about one hour.)

#### VAM System Calibration

With the seat adjusted and face camera aligned the VAM helmet was then placed on the subject's head and stabilized. The corneal eye reflection was then located so that calibration could begin. Calibration was performed with the subject seated in the driver's seat and looking forward. Since the boat was located in a well, it was possible to set up a  $16^\circ \times 16^\circ$  grid system on the side of a building located 29 feet in front of the driver's eye location. (Figure 9A and 9B). This system was divided into  $2^\circ$  increment squares so that calibration accuracy could be established to within about  $1/2^\circ$ .

Calibration was also performed on two vertical rods which were placed on the bow of the boat. Each rod extended up from the bow's surface about 10" (Figure 10). One was located on the tip of the bow. The second was located directly ahead of the operator's eye location. These were to be used for both intra-trial calibration checks and for the establishment of a "dead ahead", zero degree reference point for data reduction purposes.



Figure 9: Calibration Grid.

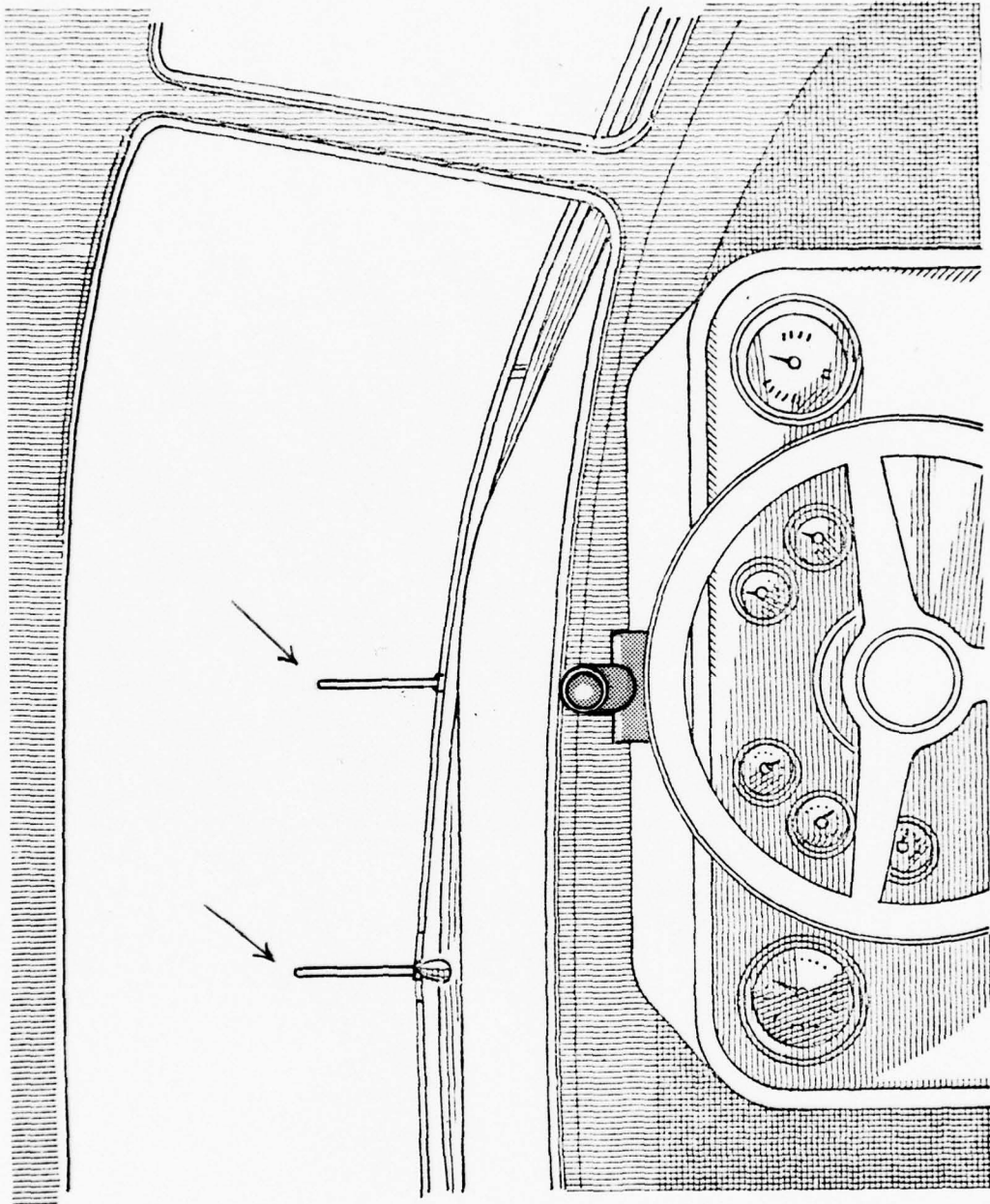

Figure 10: Bow Marker Calibration Rods

The final calibration check was to have the subject turn around 180° in the boat and look out on the water wherein he was asked to look at specific targets up to 1/2 mile away to verify that, in fact, he was calibrated for targets more distant than 29 ft. and it seemed to be the case that the 29 ft. calibration was also calibration to infinity. Recorded calibrations on the grid system, bow markers and instrument panel were conducted at the beginning of each experimental run and checks on calibration were made approximately every other leg during the experimental run itself.

#### Run #1 with Helmet

The subjects were now instructed to drive through the previously described test route (see Figure 8B, pg.24). Subject instructions during the run were kept as identical as possible for each subject and verbally recorded on the video tape sound track. Prior to approaching the start of each segment of the run, the subject was given instructions as to where to proceed and at what speed.

Upon completion of the run, which ended several miles from the home base, the subject was replaced at the helm by one of the researchers so his helmet could be removed. It was necessary to remove the helmet at this point because about one hour had elapsed and subjects became rather uncomfortable from the helmet. The subject and researchers then returned to the home base.

#### Run #2 without Helmet

After returning home, the subject was allowed to rest for approximately fifteen minutes. After this brief resting period, the

subject proceeded back through the identical course with similar instructions, only without wearing the VAM helmet. For Run #2, head movement was recorded from the face camera only.

#### Peripheral Target Viewing

After Run #2 was completed, the subject had lunch, and then performed the peripheral target viewing task. The purpose of this task as mentioned previously was to obtain 35 mm photographs of each subject at known head angles, with and without the helmet. This would aid in determining head angles during data reduction (see Figure 3B page 15).

For this peripheral viewing task, the driver sat at the helm in his normal driving position. The boat was secured in the boat well at its approximate planing angle. The peripheral targets were arrayed in a semi-circle approximately 28' from the driver's location at specified angles, as can be seen in Figures 11 and 12. This part of the task added to fatiguing the operator and occurred just before the final run. The data from this peripheral viewing exercise was used in conjunction with runs #1 and #2 so that some conclusions regarding the effect of just wearing the VAM system helmet on head movements could be drawn.

#### Run #3

The final run was the high fatigue level condition. The procedure for conducting it was identical to that described for the first run, including face camera and seat adjustment, and VAM system calibration. Whereas Run # 1 occurred in the first one and one-half hour of testing, Run #3 occurred during the fifth hour of testing.

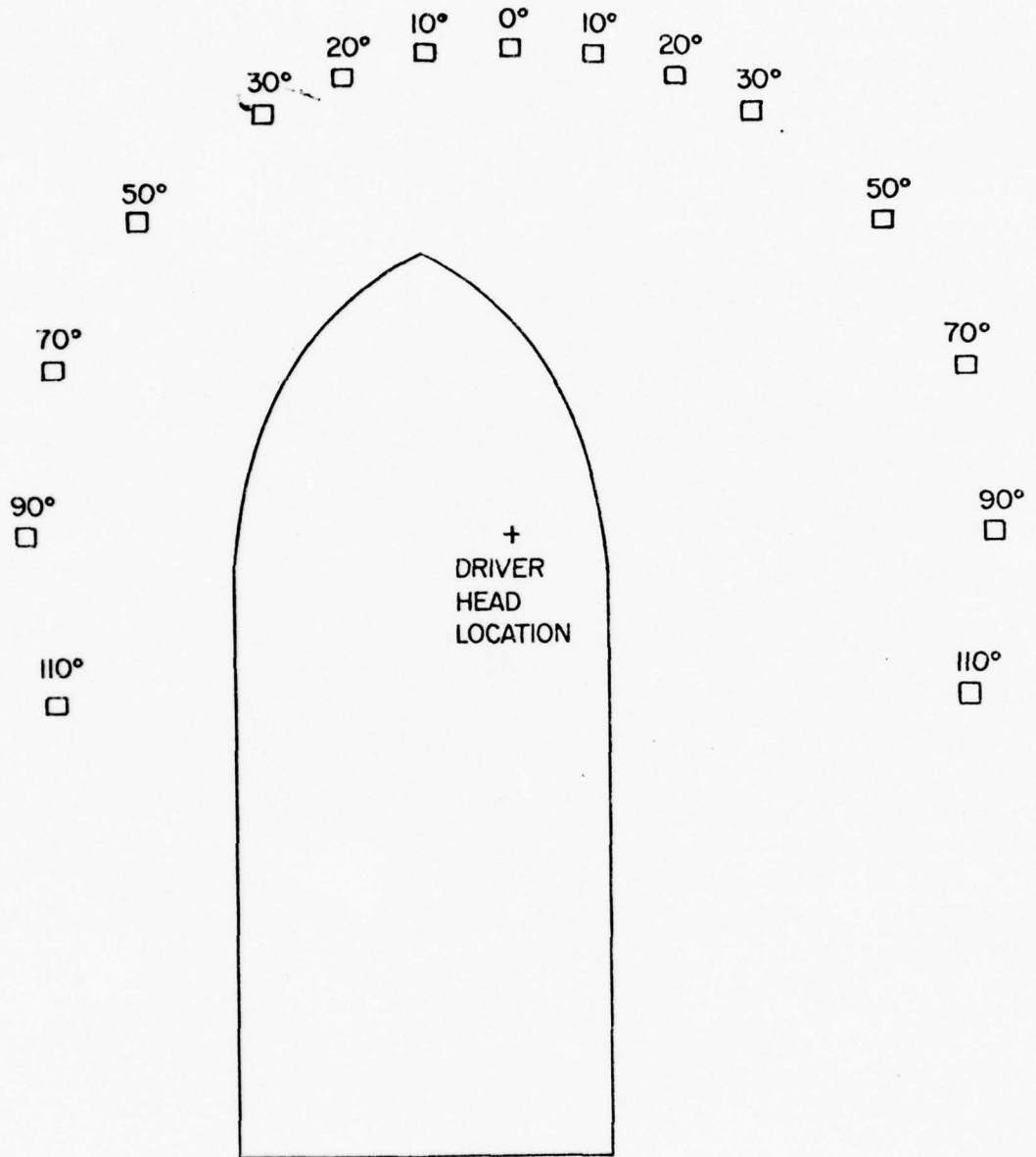

Figure 11: Peripheral Targets - Plan View

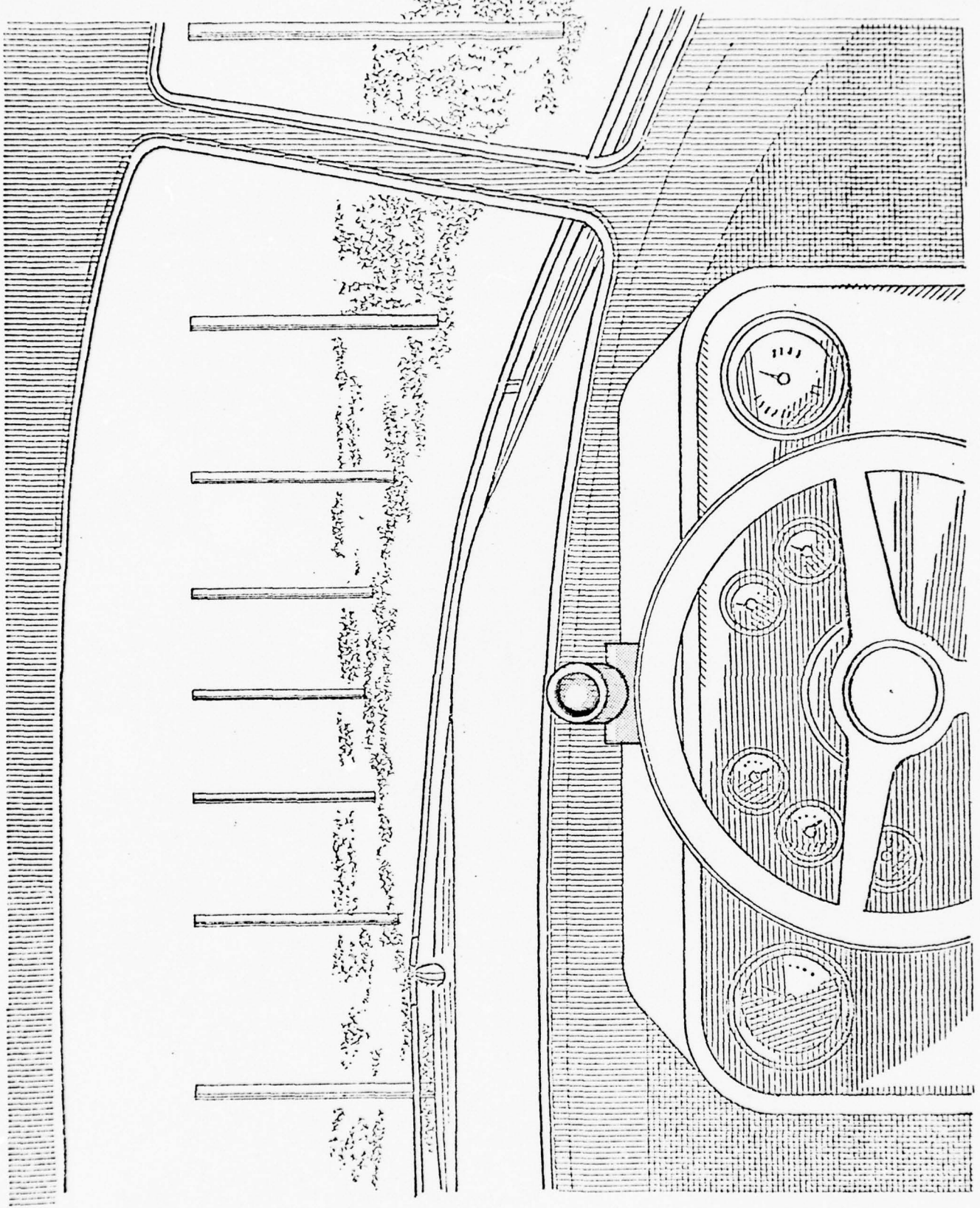

Figure 12: Peripheral Targets Through Windshield

DATA REDUCTION

An instant to instant analysis of the data was necessary in order to obtain the coordinates of each eye fixation and its corresponding target. To facilitate this type of reduction, a slow motion, stop action video tape recorder was utilized along with a television monitor. A clear acetate grid divided into two degree intervals both vertically and horizontally was superimposed on the TV monitor to determine the distance in degrees that the eye spot was from a particular reference point. It has a range of  $\pm 20^\circ$  in both axes. The eye spot was referenced to two points: the horizon; and some vertical boat marker, which was usually either one of the vertical markers on the bow or one of the boat pillars. As an example, if the boater was looking straight ahead the zero-zero reference point would be the horizon and the vertical bow marker located directly in front of him. The acetate grid would then be placed such that the zero-zero mark coordinates corresponded to these references. Then the coordinates of the eye spot in degrees could be directly read from the grid. Confirming that the degrees used for data reduction were real degrees on the screen was done by comparing the size of the calibration grid degrees (Figure 9A) with the data reduction grid degrees.

Since the electronics of the VAM system sequenced through the three different cameras, the eye camera and the field camera were never sampled simultaneously. The eye spot camera was sampled twice as often as the field camera. (See Figure 13.) The data reducers set the grid on a reference point during the field camera sequence and read the next two eye camera locations with the grid stationary. Then the grid location was altered with a new field camera sequencing.

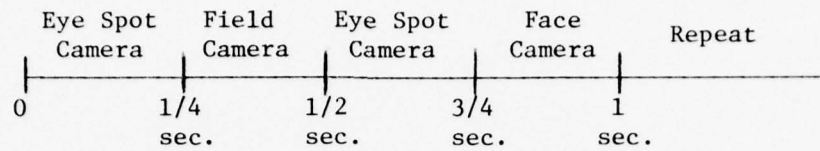

Figure 13: TV Picture Sequence Each Second.

Periodically through the testing sequence, the eye spot was recalibrated or the calibration error was determined. The data reducer determined the vertical and horizontal calibration error for a particular sequence by viewing a calibration check just prior and just after reducing a particular sequence.

After determining the coordinates of the eye fixations, the data reducer again viewed the tape to determine the traffic density and the fixation targets for each fixation. A list of the measures that the data reducers determined is contained in Table 2.

Table 2: Measures Recorded by Data Reducer.

Type of Immediate Boating Situation (i.e., another boat is approaching port)

Type of Maneuvering (i.e., subject is moving straight through light choppy water)

Traffic Density Moving (number of moving boats within 1/4 or 1/2 mile)

Traffic Density Anchored (number of anchored boats within)

Reference Point (the reference for the eye spot coordinates)

Beginning Digitizer Number (where there is no movement of eye spot)

Ending Digitizer Number (where there is no movement of eye spot)

Horizontal Coordinate of Eyespot (with respect to Dead Ahead as 0°)

Vertical Coordinate of Eye Spot (with respect to the Horizon as 0°)

Calibration Error both Horizontally and Vertically

Fixation Target (i.e., subject is fixating on a moving boat)

RESULTS

Fixations were summarized to determine the Mean Horizontal and Vertical Fixation Locations and the Standard Deviations of Horizontal and Vertical Location.

These fixations were also divided into visual areas (or zones).

These areas were as follows:

## Below Horizon Areas

Zone #1 Instrument Panel

Zone #2  $-180^{\circ}\text{L}$  to  $-45^{\circ}\text{L}$

Zone #3  $-45^{\circ}\text{L}$  to  $-15^{\circ}\text{L}$

Zone #4  $-15^{\circ}\text{L}$  to  $+15^{\circ}\text{R}$

Zone #5  $+15^{\circ}\text{R}$  to  $45^{\circ}\text{R}$

Zone #6  $45^{\circ}\text{R}$  to  $180^{\circ}\text{R}$

## Above Horizon Areas

Zone #7  $-180^{\circ}\text{L}$  to  $-15^{\circ}\text{L}$

Zone #8  $-15^{\circ}\text{L}$  to  $+15^{\circ}\text{R}$

Zone #9  $15^{\circ}\text{R}$  to  $+180^{\circ}\text{R}$

Finally, fixations were classified in accordance to the type of object viewed.

These data were analyzed using a full factorial statistical model with subjects as random effects and all non-significant mean squares were pooled. The significant main effects and interactions resulting from this statistical analysis are contained in Table 3.

Since the important independent variables included fatigue, velocity, and traffic density, these will be discussed individually in the next section. Following this, results from two other related studies (Gatchell, 1977 and Dykstra, 1977) will be presented since these other studies utilized the identical subjects and experimental set-up.

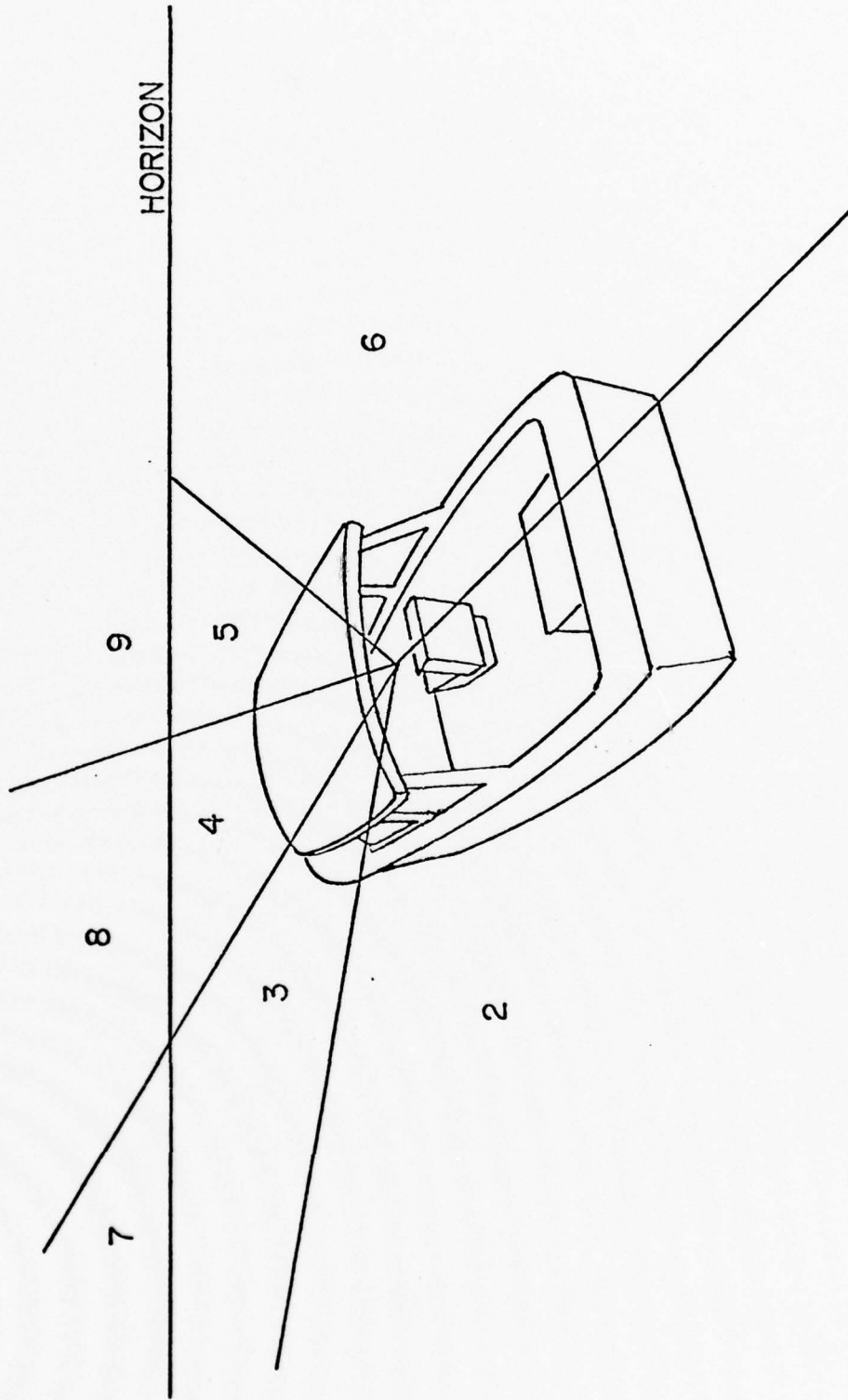

Figure 14A: Visual Zone Areas.

Table 3: Results of Analysis of Variance (ANOVA) - Main Effects  
(page 1 of 3)

| Dependent Variables             |   | Independent Variables |          |          |                 |
|---------------------------------|---|-----------------------|----------|----------|-----------------|
|                                 |   | Fatigue               | Subjects | Velocity | Traffic Density |
| Fixation Location               | Mean Horizontal Location                      |                       |          | *        |                 |
|                                 | Standard Deviation Horizontal Location        |                       |          | *        | *               |
|                                 | Mean Vertical Location                        |                       | *        |          |                 |
|                                 |   |                       |          |          |                 |
| % Fixation Time in Visual Areas | Visual Area #1<br>Instrument Panel            | **                    | *        |          |                 |
|                                 | Visual Area #2<br>(-180° to -45°)             |                       |          |          |                 |
|                                 | Visual Area #3<br>(-45° to -15°)              |                       |          |          |                 |
|                                 | Visual Area #4<br>(-15° to 15°)               | *                     | ***      |          | ****            |
|                                 | Visual Area #5<br>(15° to 45°)                |                       |          |          | *               |
|                                 | Visual Area #6<br>(45° to 180°)               |                       |          |          |                 |
|                                 | Visual Area #7<br>(-180° to -15° above hor.)  |                       |          |          |                 |
|                                 | Visual Area #8<br>(-15° to 15° above horizon) |                       | *        |          |                 |
|                                 | Visual Area #9<br>(15° to 180° above horizon) |                       |          |          | *               |
| % Fix. Time on Obj.             | Other Boats                                   |                       |          |          | ****            |
|                                 | Land or Water                                 |                       |          |          | ****            |

\* =  $\alpha < .05$  \*\* =  $\alpha < .01$  \*\*\* =  $\alpha < .005$  \*\*\*\*  $\alpha < .001$

Table 3 (cont.): Results of Analysis of Variance (ANOVA) - 2-Way Interactions (page 2 of 3)

| Dependent Variables             |   | Independent Variables |                       |                        |                                 |                                  |                                  |
|---------------------------------|---|-----------------------|-----------------------|------------------------|---------------------------------|----------------------------------|----------------------------------|
|                                 |   | Fatigue x<br>Subjects | Fatigue x<br>Velocity | Subjects x<br>Velocity | Fatigue x<br>Traffic<br>Density | Subjects x<br>Traffic<br>Density | Velocity x<br>Traffic<br>Density |
| Fixation<br>Location            | Mean Horizontal Location                      | *                     | **                    | *                      | **                              |                                  |                                  |
|                                 | Standard Deviation<br>Horizontal Location     | *                     |                       | *                      | *                               |                                  |                                  |
|                                 | Mean Vertical Location                        | ****                  |                       |                        |                                 |                                  |                                  |
|                                 |   |                       |                       |                        |                                 |                                  |                                  |
| % Fixation Time in Visual Areas | Visual Area #1<br>Instrument Panel            | *                     |                       |                        |                                 | **                               |                                  |
|                                 | Visual Area #2<br>(-180° to -45°)             |                       |                       |                        | *                               |                                  | *                                |
|                                 | Visual Area #3<br>(-45° to -15°)              |                       |                       |                        |                                 |                                  |                                  |
|                                 | Visual Area #4<br>(-15° to 15°)               | ***                   |                       | *                      |                                 | *                                |                                  |
|                                 | Visual Area #5<br>(15° to 45°)                | ***                   |                       |                        |                                 |                                  |                                  |
|                                 | Visual Area #6<br>(45° to 180°)               |                       |                       |                        |                                 |                                  |                                  |
|                                 | Visual Area #7<br>(-180° to -15° above hor.)  |                       |                       |                        |                                 |                                  |                                  |
|                                 | Visual Area #8<br>(-15° to 15° above horizon) |                       |                       |                        |                                 |                                  |                                  |
|                                 | Visual Area #9<br>(15° to 180° above horizon) |                       |                       |                        |                                 |                                  |                                  |
| % Fix. Time<br>on Obj.          | Other Boats                                   |                       |                       |                        |                                 |                                  | *                                |
|                                 | Land or Water                                 |                       |                       |                        |                                 |                                  | *                                |

\* =  $\alpha < .05$  \*\* =  $\alpha < .01$  \*\*\* =  $\alpha < .005$  \*\*\*\* =  $\alpha < .001$

Table 3 (cont.): Results of Analysis of Variance (ANOVA) - 3-Way Interactions (page 3 of 3)

| Dependent Variables             |   | Independent Variables               |   |   |  |   |
|---------------------------------|---|-------------------------------------|---|---|--|---|
|                                 |   | Fatigue x<br>Subjects x<br>Velocity | Fatigue x<br>Subjects x<br>Traffic<br>Density | Fatigue x<br>Velocity x<br>Traffic<br>Density | Subjects x<br>Velocity x<br>Traffic<br>Density | Fatigue x<br>Subjects x<br>Velocity x<br>Traffic<br>Density |
| Fixation<br>Location            | Mean Horizontal Location                      |                                     | *   |   |  | *   |
|                                 | Standard Deviation<br>Horizontal Location     |                                     | *   |   |  |   |
|                                 | Mean Vertical Location                        | *                                   |   | *   |  |   |
| % Fixation Time in Visual Areas | Visual Area #1<br>Instrument Panel            |                                     |   |   | ***  | ***   |
|                                 | Visual Area #2<br>(-180° to -45°)             |                                     |   |   |  |   |
|                                 | Visual Area #3<br>(-45° to -15°)              |                                     |   |   |  |   |
|                                 | Visual Area #4<br>(-15° to 15°)               |                                     |   |   |  |   |
|                                 | Visual Area #5<br>(15° to 45°)                | ***                                 | ***   | *   |  |   |
|                                 | Visual Area #6<br>(45° to 180°)               |                                     |   | *   |  |   |
|                                 | Visual Area #7<br>(-180° to -15° above hor.)  |                                     |   |   |  |   |
|                                 | Visual Area #8<br>(-15° to 15° above horizon) |                                     |   |   |  |   |
|                                 | Visual Area #9<br>(15° to 180° above horizon) | **                                  |   |   |  |   |
| % Fix. Time<br>on Obj.          | Other Boats                                   |                                     |   |   |  |   |
|                                 | Land or Water                                 |                                     |   |   |  |   |

\* =  $\alpha < .05$  \*\* =  $\alpha < .01$  \*\*\* =  $\alpha < .005$  \*\*\*\*  $\alpha < .001$

FATIGUE EFFECTSFatigue Effects in Visual Zone Percentages

For this analysis the looking environments were divided into areas or zones. The summary of data for this occurs in Table #4. The differences in this visual behavior due to fatigue seemed to occur with respect to the subjects' viewing of the instrument panel (Zone #1) and visual field ahead of the boat (Zone #4,  $-15^{\circ}$ L to  $+15^{\circ}$ R below the horizon). At higher levels of fatigue subjects looked at the instrument panel less and tended to look more in the #4 visual zone below the horizon but in front of the boat. This is opposed to looking above the horizon more in the low fatigue state. The relevant percentages from which these results arise are listed in Table 5.

These findings are supportive of previous findings and human performance theory which has told us that as the human becomes less "alert", "attentive" or "vigilant" due to things such as "fatigue", "alcohol" or "boredom" he tends to look closer in to the vehicle being operated (below the horizon in this case) and spends less time attending to secondary type tasks (the instrument panel monitoring, in this case).

Fatigue Effects in Mean Fixation Location

The summarized data of the horizontal and vertical fixation locations by degrees is contained in Table 6. The analysis of variance of this data revealed no "main effect" significance. However, there were three fatigue-involved interactions worthy of noting.

Table 4: Visual Zone Percentages (%)

|              | Visual Zones | Low Velocity |              | High Velocity |              | Across Condition |
|--------------|--------------|--------------|--------------|---------------|--------------|------------------|
|              |              | Low Density  | High Density | Low Density   | High Density |                  |
| Low Fatigue  | 1            | 5.4%         | 5.9%         | 3.9%          | 3.6%         | 4.7              |
|              | 2            | 5.9%         | 1.1%         | .3%           | 1.5%         | 2.2              |
|              | 3            | 4.1%         | 4.2%         | 3.1%          | 5.5%         | 4.2              |
|              | 4            | 34.7%        | 23.4%        | 36.9%         | 26.0%        | 30.2             |
|              | 5            | 5.2%         | 3.7%         | 2.0%          | 7.7%         | 4.6              |
|              | 6            | 2.8%         | .5%          | 1.3%          | 3.7%         | 2.1              |
|              | 7            | 9.0%         | 6.6%         | 9.7%          | 7.1%         | 8.1              |
|              | 8            | 28.6%        | 45.9%        | 40.1%         | 40.4%        | 38.7             |
|              | 9            | 4.4%         | 8.0%         | 2.8%          | 4.8%         | 5.2              |
|              |              |              | 100.0%       | 100.0%        | 100.0%       | 100.0%           |
| High Fatigue | 1            | 1.1%         | 4.1%         | 1.0%          | 3.3%         | 2.4              |
|              | 2            | 2.1%         | 3.4%         | 0 %           | 9.4%         | 3.7              |
|              | 3            | 6.6%         | 10.4%        | 1.6%          | 8.0%         | 6.7              |
|              | 4            | 42.6%        | 29.7%        | 54.1%         | 25.9%        | 38.1             |
|              | 5            | 4.6%         | 11.3%        | 5.4%          | 6.5%         | 6.9              |
|              | 6            | .4%          | 2.3%         | 3.4%          | 1.8%         | 2.0              |
|              | 7            | 5.1%         | 5.7%         | 1.2%          | 14.2%        | 6.5              |
|              | 8            | 35.2%        | 26.8%        | 29.5%         | 25.0%        | 29.1             |
|              | 9            | 2.7%         | 6.3%         | 3.9%          | 6.1%         | 4.7              |
|              |              |              | 100.0%       | 100.0%        | 100.0%       | 100.0%           |

Table 5: Fatigue Effects in Visual Zone Percentages

|              | Zone #1          | Zone #8                         | Zone #4                         |
|--------------|------------------|---------------------------------|---------------------------------|
|              | Instrument Panel | Above Horizon<br>-15°L to +15°R | Below Horizon<br>-15°L to +15°R |
| Low Fatigue  | 4.7%             | 38.7%                           | 30.2%                           |
| High Fatigue | 2.4%             | 29.1%                           | 38.1%                           |

Table 6: Horizontal and Vertical Fixation Locations - Means and Standard Deviations\*

|              |                |   | Low Velocity    |              | High Velocity   |             |
|--------------|----------------|---|-----------------|--------------|-----------------|-------------|
|              |                |   | Traffic Density |              | Traffic Density |             |
|              |                |   | Low             | High         | Low             | High        |
| Low Fatigue  | S <sub>1</sub> | H | -3.3 ± 17.0     | -9.2 ± 24.9  | -3.7 ± 8.9      | -3.1 ± 22.0 |
|              |                | V | -3.4 ± 4.4      | -1.5 ± 5.7   | .5 ± 2.5        | -2.0 ± 5.5  |
|              | S <sub>2</sub> | H | -15.2 ± 24.8    | 11.0 ± 18.1  | 7.4 ± 8.4       | 2.1 ± 16.4  |
|              |                | V | .5 ± 4.8        | -3.0 ± 5.5   | -4.0 ± 7.5      | -5.4 ± 8.7  |
|              | S <sub>3</sub> | H | 9.3 ± 19.7      | 8.8 ± 18.0   | -13.3 ± 29.4    | 2.8 ± 19.5  |
|              |                | V | .5 ± 4.9        | 4.4 ± 3.9    | 1.7 ± 4.7       | -.2 ± 4.5   |
|              | S <sub>4</sub> | H | 2.2 ± 22.8      | -1.5 ± 9.0   | -7.9 ± 10.7     | 0 ± 12.5    |
|              |                | V | -.8 ± 7.2       | 2.6 ± 3.2    | 1.0 ± 2.0       | 1.3 ± 4.7   |
| High Fatigue | S <sub>1</sub> | H | -2.9 ± 19.5     | -5.3 ± 29.4  | 8.5 ± 18.8      | 8.8 ± 17.0  |
|              |                | V | -.8 ± 2.0       | -1.2 ± 6.9   | -1.5 ± 2.0      | -1.6 ± 6.6  |
|              | S <sub>2</sub> | H | -2.9 ± 24.3     | -41.4 ± 31.6 | 5.0 ± 7.0       | -3.5 ± 25.0 |
|              |                | V | 0 ± 35          | .2 ± 4.4     | 1.7 ± 5.3       | 1.4 ± 3.9   |
|              | S <sub>3</sub> | H | .4 ± 8.0        | -13.0 ± 12.5 | 5.8 ± 20.0      | 5.9 ± 16.1  |
|              |                | V | 0 ± 3.0         | -2.8 ± 5.5   | -.6 ± 3.5       | -.4 ± 4.4   |
|              | S <sub>4</sub> | H | -2.6 ± 14.7     | 1.7 ± 35.4   | 3.0 ± 12.7      | -3.9 ± 29.0 |
|              |                | V | .7 ± 3.4        | -1.4 ± 3.2   | -1.0 ± 4.7      | 0 ± 3.1     |

\* For horizontal degrees (H), reference is "dead ahead" at 0° and negative values are to port (left of center).  
For vertical degrees (V), reference is horizon at 0° and negative values are below horizon (down).

The first column of numbers in each cell are means. The second column of values (following the ±) are dispersions about the mean expressed here as one standard deviation.

#### Fatigue-Velocity Interaction

Table 7 gives the horizontal and vertical location means and standard deviations related to fatigue and velocity. The significance in this table comes from the mean horizontal fixation changes which occur. That is at low velocities, the fatigue effect is to cause the operator to look 8.6° further to the left. At high velocities, the fatigue apparently causes operators to look more to the right by 5.7°.

A strictly speculative interpretation of this might be that:  
 (a) at low velocity, the operator tends to become less attentive to his primary task with fatigue and looks to the left to talk to the passengers instead of monitoring traffic in front of him; and (b) the high velocity fatigue effect is to cause a bias in his search patterns towards the starboard quadrants.

Table 7: Horizontal and Vertical Fixation Locations - Fatigue vs. Velocity Cell Means

|   | Velocity                             |                                      | Means for Fatigue<br>Across<br>Low & High Velocity |
|---|--------------------------------------|--------------------------------------|--|
|   | Low                                  | High                                 |  |
| Low<br>Fatigue  | H $+3 \pm 19.4$<br>V $-.1 \pm 5.0$   | H $-2.0 \pm 16.0$<br>V $-.9 \pm 5.0$ | H $-.9 \pm 17.7$<br>V $-.49 \pm 5.0$               |
| High<br>Fatigue   | H $-8.3 \pm 21.9$<br>V $-.7 \pm 4.0$ | H $+3.7 \pm 18.2$<br>V $-.3 \pm 4.2$ | H $-2.3 \pm 20.1$<br>V $-.46 \pm 4.1$              |
| Means for<br>Velocity<br>Across<br>Low &<br>High<br>Fatigue | H $-4.0 \pm 20.7$<br>V $-.4 \pm 4.5$ | H $+0.9 \pm 17.1$<br>V $-.6 \pm 4.6$ |  |

Fatigue-Traffic Density Interaction

The data relevant to comparing the interactive effects of fatigue and traffic density appear in Table 8. This data suggests that at low densities, fatigue tends to shift the horizontal looking to the right by 4.9°, and at high densities, fatigue causes the opposite effects, bringing the horizontal looks back to the left by 7.7°.

Regarding the spread or standard deviation of the horizontal looks at the low fatigue level, traffic density did not change the horizontal distribution of looks. However, at the high fatigue level subjects tended to have a narrower looking pattern in low traffic and overreact to high traffic levels by a greatly expanded horizontal looking pattern.

Table 8: Horizontal and Vertical Fixation Locations - Fatigue vs. Density Cell Means

|  | Traffic Density                      |                                      | Means for Fatigue<br>Across<br>Low & High Density |
|--|--------------------------------------|--------------------------------------|---|
|  | Low                                  | High                                 |   |
| Low<br>Fatigue   | H $-3.1 \pm 17.8$<br>V $-.5 \pm 4.8$ | H $1.4 \pm 17.6$<br>V $-.5 \pm 5.2$  | H $-.9 \pm 17.7$<br>V $-.5 \pm 5.0$               |
| High<br>Fatigue  | H $1.8 \pm 15.6$<br>V $-.2 \pm 3.4$  | H $-6.3 \pm 24.5$<br>V $-.7 \pm 4.8$ | H $-2.3 \pm 20.1$<br>V $-.5 \pm 4.1$              |
| Means for<br>Traffic<br>Density<br>Across Low<br>& High<br>Fatigue | H $-.7 \pm 16.7$<br>V $-.3 \pm 4.1$  | H $-2.5 \pm 21.0$<br>V $-.6 \pm 5.0$ |   |

(5)

One can also speculate about these findings by asking such questions as: (a) Does the narrower looking pattern when fatigued indicate less attentiveness to the low probability peripherally located potential collision traffic? and (b) does the expanded looking patterns in the high density-high fatigue condition support a decrease in the peripheral vision capability due to fatigue, and is this compensated for by additional foveal fixations to the periphery? (Findings from automobile operator fatigue and vision research suggests this latter question's answer is "yes".)

Fatigue - Subject Interaction

An interaction between fatigue and subject in this case means that not all subjects responded in the same way to the increased fatigue level. Table 9 indicates that three of four subjects looked more to the

Table 9: Horizontal and Vertical Look Location - Fatigue vs. Subject Cell Means

|              |                | Means Across Subjects |              |
|--------------|----------------|-----------------------|--------------|
| Low Fatigue  | S <sub>1</sub> | H                     | -4.8 ± 18.2  |
|              |                | V                     | -1.6 ± 4.5   |
|              | S <sub>2</sub> | H                     | -1.3 ± 17.2  |
|              |                | V                     | -3.0 ± 6.6   |
|              | S <sub>3</sub> | H                     | -1.9 ± 21.7  |
|              |                | V                     | +1.6 ± 4.5   |
|              | S <sub>4</sub> | H                     | -1.8 ± 13.8  |
|              |                | V                     | 1.0 ± 4.3    |
|              |                | H                     | -0.9 ± 17.7  |
|              |                | V                     | -0.49 ± 5.0  |
| High Fatigue | S <sub>1</sub> | H                     | -2.3 ± 21.2  |
|              |                | V                     | -1.3 ± 4.4   |
|              | S <sub>2</sub> | H                     | -10.7 ± 22.0 |
|              |                | V                     | .8 ± 4.3     |
|              | S <sub>3</sub> | H                     | -.2 ± 14.2   |
|              |                | V                     | -1.0 ± 4.1   |
|              | S <sub>4</sub> | H                     | -.5 ± 23.0   |
|              |                | V                     | -.4 ± 3.6    |
|              |                | H                     | -2.3 ± 20.1  |
|              |                | V                     | -.46 ± 4.1   |

right at the higher fatigue level. Similarly, three of four subjects had an increase in their dispersion (standard deviation) of looks at the higher fatigue level. The opposite behavior by the fourth subject in each case caused the fatigue main effect not to be statistically significant and the overall mean for the subjects to be opposite.

#### VELOCITY EFFECTS

As opposed to fatigue which showed its statistical main effects with respect to visual zone percentages, velocity effected the horizontal looking location means and standard deviation. The relevant cell means which support these Table 3 (page 45) findings are given in Table 10. Therein it is seen that subject mean looks were  $4.9^\circ$  further to the right (to dead ahead) when in the high velocity condition. Also, a decrease in the standard deviation of these looks by  $3.6^\circ$  occurred. This change in visual behavior is further illustrated in Figure 14.

Table 10: Horizontal and Vertical Look Location - Subject vs. Velocity Cell Means

|                |   | Low Velocity |               | High Velocity |             |
|----------------|---|--------------|---------------|---------------|-------------|
| S <sub>1</sub> | H | -5.2 ± 22.7  |               | 2.6 ± 16.7    |             |
|                | V | -1.7 ± 4.8   |               | -1.2 ± 4.2    |             |
| S <sub>2</sub> | H | -12.1 ± 25.0 | H -4.0 ± 20.7 | 2.8 ± 14.2    | H .9 ± 17.1 |
|                | V | -.6 ± 4.6    |               | -1.6 ± 6.4    |             |
| S <sub>3</sub> | H | 1.4 ± 14.6   | V -.4 ± 4.5   | .3 ± 21.3     | V -.6 ± 4.6 |
|                | V | .5 ± 4.3     |               | .1 ± 4.3      |             |
| S <sub>4</sub> | H | -.1 ± 20.5   |               | -2.2 ± 16.3   |             |
|                | V | .3 ± 4.3     |               | .3 ± 3.6      |             |

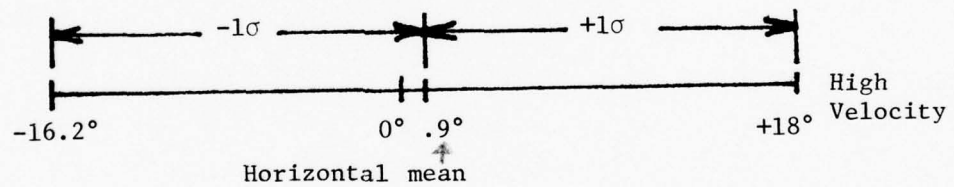
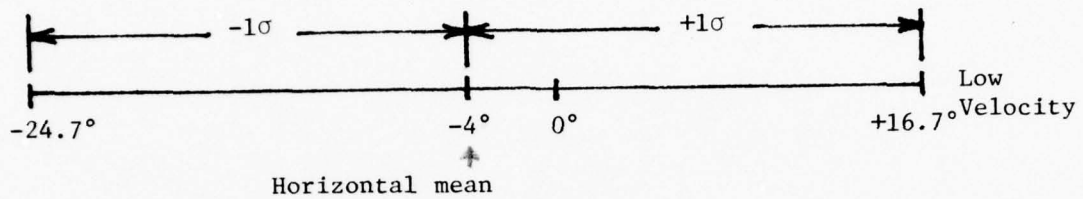

Figure 14B: Distribution of Horizontal Looks - Low vs. High Speed.

$\sigma$  = one standard deviation. This statistical concept is useful to express how spread out the data is. About two thirds of all the data normally will be distributed within  $\pm$  one standard deviation of the mean value ( $\text{mean} \pm 1 \sigma$ ). In the top figure this would be interpreted that 67% of all the "Low Velocity" looks were between  $24.7^\circ$  to the left of dead ahead and  $16.7^\circ$  to the right of dead ahead.

TRAFFIC DENSITY EFFECTVisual Zone Percentages - Density vs. Velocity

Traffic density was an important factor in changing particularly the behavior measured by the "visual zone percentage" variable (the percent of time spent looking in each zone). At the higher density level the looking was less concentrated on Zone #4 ( $-15^{\circ}$ L to  $+15^{\circ}$ R below horizon) and spread out to the other zones, particularly Zone #5 ( $+15^{\circ}$ R to  $+45^{\circ}$ R). This effect was most noticeable in the high velocity condition as shown under Zone #4 in Table 11.

Recall that Zone #8 contains  $-15^{\circ}$ L to  $+15^{\circ}$ R above the horizon. This, while consuming about one-third of the percentage by time, did not seem to vary much as a function of velocity or density.

Table 11: Visual Zone Percentages - Velocity and Traffic Density  
Cell Means

|                  | Visual Zone | Low Velocity |              | High Velocity |              |
|------------------|-------------|--------------|--------------|---------------|--------------|
|                  |             | Low Density  | High Density | Low Density   | High Density |
| Below<br>Horizon | 1           | 3.2          | 5.0          | 2.4           | 3.4          |
|                  | 2           | 4.0          | 2.2          | .2            | 5.4          |
|                  | 3           | 5.3          | 7.3          | 2.3           | 6.8          |
|                  | 4           | 38.6         | 26.5         | 45.5          | 25.9         |
|                  | 5           | 4.9          | 7.5          | 3.7           | 7.1          |
|                  | 6           | 1.6          | 1.4          | 2.3           | 2.7          |
| Above<br>Horizon | 7           | 7.1          | 6.1          | 5.5           | 10.6         |
|                  | 8           | 31.9         | 36.3         | 34.8          | 32.7         |
|                  | 9           | 3.5          | 7.6          | 3.3           | 5.4          |

Traffic Density Effect on Mean Fixation Location

The traffic density variable proved to have a significant effect on the standard deviation of the horizontal location. Subjects scanned a larger area in the high traffic density situation by 5° than in the low traffic density situation, as shown in Table 8, (page 52).

Traffic Density Effect on Objects Viewed Percentages

This visual behavior variable was only affected by traffic density, as the Table 3 ANOVA results indicated. An ordering by percentage of the categories for the different tasks is given in Table 12. Here it is revealed that the boater (expectedly) spends the largest portion of time looking at the "land or water" except when maneuvering in high density areas. Then he pays attention primarily to the other boats around him. Part of this attention may be for collision avoidance purposes and part may be a general curiosity concerning the details about other boats or people in boats. This is certainly not a surprising result.

The above analysis is most interesting because it provides for the first time some estimates of what percent time a boater's attention is given to various objects. To generalize, one could say that boaters scan the land or water from about 25% to 80% of the time depending on traffic density; and they spend from about 2% to 55% of the time looking at other boats, depending on traffic density.

Table 12: Objects Viewed Percentages (%) - Density vs. Velocity

| Maneuvering<br>(Low Velocity) |                        | Cruising<br>(High Velocity) |                        |
|-------------------------------|------------------------|-----------------------------|------------------------|
| Traffic Density               |                        | Traffic Density             |                        |
| Low                           | High                   | Low                         | High                   |
| 81.6%<br>Land or Water        | 54.7%<br>Other Boats   | 78.3%<br>Land or Water      | 58.9%<br>Land or Water |
| 4.9%<br>Navigation Aids       | 26.5%<br>Land or Water | 8.3%<br>Sky                 | 30.1%<br>Other Boats   |
| 3.6%<br>Sky                   | 5.3%<br>Sky            | 7.6%<br>Other Boats         | 5.0%<br>Instruments    |
| 3.2%<br>Instruments           | 3.0%<br>Instruments    | 3.2%<br>Bow of Boat         | 3.0%<br>Bow of Boat    |
| 3.2%<br>Bow of Boat           | 2.9%<br>Bow of Boat    | 2.5%<br>Instruments         | 2.6%<br>Sky            |
| 1.9%<br>Other Boats           |                        |                             |                        |

RESULTS FROM RELATED STUDIESLooking Time Durations

Analysis of variance was not performed on the durations of individual fixations due to the effect of sequencing through the four cameras. This sequencing resulted in fixation durations being no longer than 1 sequence or 250 msec. and it is known that fixation durations for the boater are probably twice that long. A recent report by Gatchell (1977) indicated that the fixation durations of these same subject boaters was approximately 500 msec. In addition to this she found that the velocity of the boat and the task the boater was performing had a significant effect on the duration measures. When the subjects were aiming their boat toward a distant point (i.e., a water tower) their fixation durations decreased as the velocity increased. However, when the subjects were centering their boat in a channel the fixation durations increased as the speed increased.

Effects of Wearing VAM Helmet

Recall that Run #2 was made without the subject wearing the helmet. In a separate analysis and report by Dykstra (1977) the results comparing the helmet vs. no helmet conditions were given. In the majority of cases, subjects spent a greater percentage of time in the forward viewing sector, 15°L - 15°R (Sector 4) while wearing the helmet than when not wearing the helmet.

As shown in Figure 15, the helmet significantly decreased the time that subjects' head angles were at the extreme periphery (head angles  $> 45^\circ$ ). Without the helmet, 21.4% of the time was spent with head angles in the periphery, whereas only 8.0% of the time was spent with head angles in the periphery with the helmet on.

More specifically, subjects during high speed conditions seemed to spend more time in the forward viewing sectors when wearing the helmet. The helmet, then, may cause subjects to spend more time looking forward and less time looking to the periphery during these conditions.

One cannot determine for sure whether the subjects were really looking less in the peripheral areas based on these results. It is possible that while the head angle percentages were decreased, eye fixations may not have been. The eyes instead had to work harder by rotating further than usual to compensate for the decreased head angle. Nevertheless, this study points up the need for caution when interpreting data gathered while wearing the helmet. It may give a slight bias to results. (From Dykstra, 1977.)

WITH HELMET

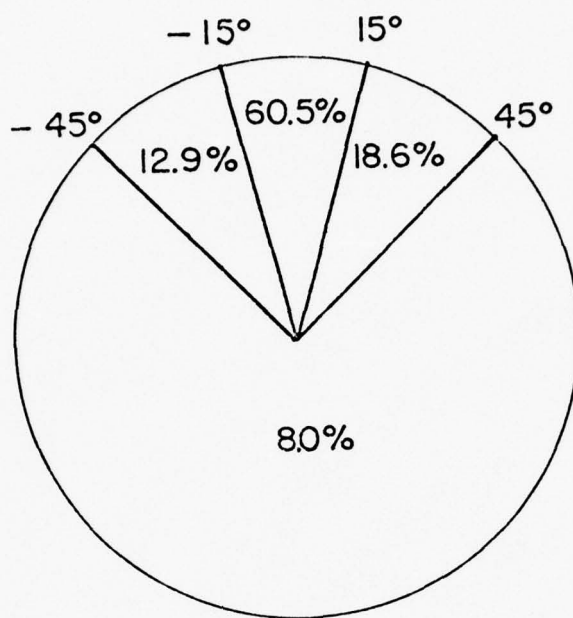

WITHOUT HELMET

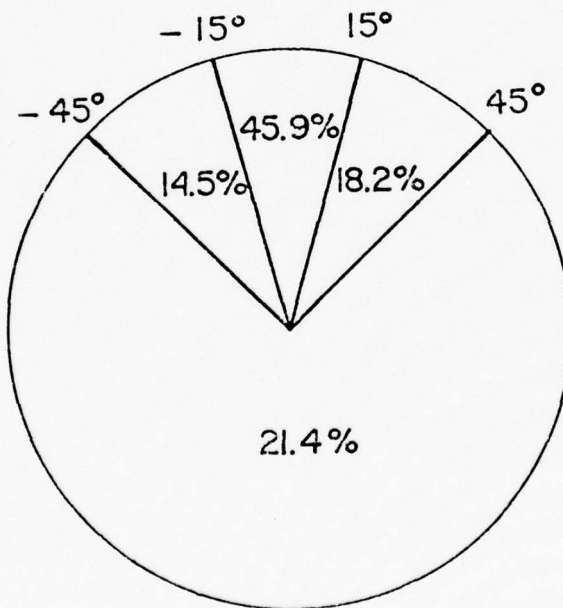

Figure 15: Head Angle Mean % Time/Zone.

SUMMARY OF RESULTS

The previous section discussed the formal results of the study in terms of primarily the statistical analyses findings presented in Table 3 (page 43). The effects of fatigue, velocity (maneuvering vs. cruising), and traffic density were of primary interest in terms of how they affected the response variables of mean horizontal and vertical eye fixations, percentage time spent in different visual zones, percent time looking at different types of objects, and eye fixation durations. Those significant statistical results which were very strong and did not depend on interactive effect interpretation are summarized in Table 13.

Table 13: Summary of Results

|  | Effects of                          |                        |                             |
|--|-------------------------------------|------------------------|-----------------------------|
|  | Fatigue Increasing                  | Density Increasing     | Velocity Increasing         |
| Horizontal Look Degrees<br>Mean<br>S.D.  |                                     | increases              | moves to right<br>decreases |
| Vertical Look Degrees<br>Mean<br>S.D.  |                                     |                        |                             |
| Visual Zone Percentages<br>Instrument Panel<br>Zone #8 above hor.<br>Zone #4 below hor.    | decreases<br>decreases<br>increases | decreases              |                             |
| Objects Viewed Percentage<br>Other boats<br>Land or Water                                  |                                     | increases<br>decreases |                             |
| Durations of Fixation<br>Task: Aiming for Distant Point<br>Task: Centering Boat in Channel |                                     |                        | decreases<br>increases      |

In addition to these main effects there were a number of significant interactions which were interpreted in the task section. The combination of these main effects and interactive effects have demonstrated that indeed the visual behavior of boat operators is affected by fatigue, traffic density and velocity. The results also yielded the expected findings that all subjects do not respond in the same way to these higher level of stressors (fatigue, traffic density and velocity).

From Table 13, then, the following summarizes the changes in visual behavior found in this study:

1. As fatigue increases, subjects spent less time looking at the instrument panel, decreased the amount of time spent looking directly ahead of the boat but above the horizon, and increased the amount of time spent looking ahead of the boat but between the bow of the boat and the horizon. Thus, increasing fatigue seemed to cause the subjects to pay less attention to the secondary task represented by instrument panel monitoring and concentrate their visual looking to the area just in front of the boat, as opposed to scanning for visual information further out and slightly above the horizon.
2. Increasing traffic density tended to increase the dispersion of the subject's looking pattern distribution, as noted by an increase in the standard deviation for horizontal look degrees. This higher level of density also decreased the amount of time spent in Zone #4 in front of the boat directly below the horizon. And, as would be expected with increasing

density, the subjects' time was necessarily directed more to looking at other boats as opposed to scanning land or water as in the lower density conditions.

3. As velocity increased, the subjects' mean horizontal look degrees were shifted slightly to the right to an almost dead ahead position. This was accompanied by a decrease in the dispersion of looks (standard deviation) as measured by the horizontal look degrees. Subjects were obviously concerned at the higher velocity with the visual information directly in front of them as opposed to information which might be more to the periphery. They might not have felt that they had time to look to the periphery when operating at high velocity. The shift in the mean horizontal look degree because of velocity may have been caused by the fact that the subject spent less time looking at or talking to the experimenter to the left of him. It may also have been that the left bias was due to the fact that subjects actually spent more time scanning the visual area to their left due to boat structure visual interference.

Over and above showing how visual behavior changed as a result of the fatigue, density, velocity and task variables, an equally important contribution of this research would certainly seem to be just the fact that we now have estimates of some additional characteristics of boaters' visual behavior which previous to this study had never

been measured or estimated. Some of these general visual behavior findings are as follows:

1. The horizontal mean of boat operators' fixation seems to be between dead ahead ( $0^\circ$ ) and  $-5^\circ$ L.
2. The mean vertical fixation for boaters ranges between  $-3^\circ$  below the horizon to  $1-1/2^\circ$  above the horizon.
3. The standard deviation of horizontal looks is between  $10^\circ$  and  $30^\circ$  and highly variable across subjects and conditions.
4. The standard deviation of vertical fixations is between  $2^\circ$  and  $5^\circ$  and considerably more consistent across subjects and conditions than horizontal fixations.
5. The amount of time subjects spend looking at the instrument panel ranges from 2% to 5%.
6. The percentage of time spent looking in the zone directly ahead of the boat ( $15^\circ$ L to  $15^\circ$ R) is between 55% and 80%. Within this frontal area percentage, more time is spent looking above the horizon during low fatigue conditions and more time is spent looking below the horizon in high fatigue conditions.
7. In terms of objects being viewed, the percent time spent looking at land or water ranges from 25% to 85%; and for looking at other boats, from 2% to 55%. These are most highly affected by traffic density, as expected.
8. The duration of single fixations per boater seems to have a mean of about 500 msec. This is slightly longer than the fixation means of operators of other types of vehicles.

DISCUSSION OF RESULTS

The results just discussed have demonstrated that it is feasible to collect fairly sophisticated data to help identify boat operators' visual behavior characteristics. It was also shown that the stressors (fatigue, velocity and traffic density) do tend to affect these visual behavior characteristics. The question then arises of what importance was this research and its findings with respect to potential causes of boating collisions?

There were several aspects of the contract that can be related to potential collision problems. Besides the formal findings from the collected data, there were also some things learned from just observing the various subjects during the some 50 hours of boat operation in which these operators were subjectively observed as well as having their formal visual behavior recorded. During these 50 hours there were a number of instances in which the boat operator subjects did not see traffic which was on potentially collision courses and one of the experimenters would have to point out such traffic to avoid a potential collision. In one such instance the subject apologized not seeing a definite collision potential because it was hidden behind one of the windshield supports. However, the subject also did not tend to move his head around in such a way that he even tried to compensate for the window structures, and it would have been possible for him to see the boat if he would have moved his upper body so that he would be viewing the surrounding water from different eye locations and would have been able to see around the pillars. This suggests the question as to how the location and width of the various obstructing structures of the boat affects the probability of collision and how they might

affect the actual visual behavior patterns. This may be an issue as important as the problem of fatigue, alcohol, or some of the other stressors of present concern to boating collision research. A useful study would be to conduct an experiment in which under nearly identical conditions a boat without any structures to obscure vision was compared to one which did have obstructing structures. This would not be difficult since a few of the models now being marketed provide 360° unlimited visibility for operators. In addition to the effect that such unobscured visibility might have on behavior patterns one would eventually want to look at boating accident report data to establish if these types of "unobscured vision boats" do in fact have a lower number of collisions associated with them. Of course, to do this, exposure information is necessary and researchers must continue working on how to get this information.

The study indicated that there was generally a bias in subjects in their horizontal looking such that the mean looking location was to the left of center several degrees, particularly in the low velocity and low density conditions. These conditions represent a lower loading on the operator and this "port side bias" might, in fact, indicate either (a) the tendency to move the head in the direction of the other occupants so as to be able to talk to them and thus end up looking more on the port side, or (b) the fact that seeing to the left is a more difficult task and requires more time. The location of the helm seat and boating structures may contribute to this behavior. Because of such bias there may be more of a collision potential on one side of the boat than the other. The cause of such bias could be further explored by

experimenting with similar boats having the helm position located on the left (port) side as compared to a helm position located in the center or traditional starboard side.

The finding that fatigue seemed to cause the operator's mean vertical looking location to be below the horizon as opposed to being above the horizon in the lower fatigue condition, was a particularly interesting result. This in conjunction with differences in the dispersion (standard deviations) of the looks under the fatigued conditions can be viewed as possibly relating to a decreased operator capability to detect information peripherally. Recalling some of the interactions found under low fatigue conditions the increasing traffic density did not change the distribution of horizontal looks. However, in the high fatigue conditions, subjects had a narrower looking pattern in low traffic and overreacted with a significantly expanded looking pattern in higher traffic levels. This also supports earlier research that contends that under fatigue conditions subjects have a more "tunnel vision" capability and must utilize foveal vision to obtain information that might have been obtained peripherally under low fatigue conditions. This would also support the findings from the Wyle Laboratories' VAST studies earlier which seem to indicate a deterioration in peripheral vision with fatigue. While one may not be able to eliminate fatigue this researcher comes back to the point of asking to what extent can we minimize its effects? Since the operator apparently is having more problems obtaining his visual information when fatigued, the presence of a number of visual obstructions caused by boating structure may be contributory to a lower probability of detecting potential collision boats. "Boat

obstructed vision" would include problems encountered due to both solid boating structures and the limitations on vision caused by such things as tinted glass, dirty windshields, or sea spray.

Recall also that one of the effects of fatigue was to decrease slightly the amount of time spent looking at the instrument panel. This finding supports other researchers' findings that when subjects are in a degraded condition from such things as fatigue or alcohol, they have more difficulties in performing both the primary tasks and all secondary tasks required; they will, thus, decrease their time spent on secondary tasks, forget to do them, or do them unsafely. These secondary tasks might include monitoring speed, direction, engine status and level of fuel; turning on navigation lights; and procedures for re-starting engine safely. This suggests that some secondary tasks may justify auditory devices which indicate important changes in status of the boat and which could lead to potential problems if not recognized and attended to.

In reviewing the total of this previous discussion, three factors emerge as having potential relevance to the collision problem because of their probable effect on visual behavior and/or attention. These factors are: fatigue, velocity and visual interference.

Based on this study's results, additional investigation should concentrate on these fatigue effects:

- (a) "the tunnel vision phenomenon" (decreased peripheral vision capability)
- (b) the decreased attention to secondary tasks, and
- (c) the decrease in the amount of distance previewed in front of boat.

Velocity related findings suggest that further interest might be warranted to determine (a) the extent to which potential collision target detection is affected and (b) the importance of passenger interaction (communication) in affecting visual searching characteristics.

Finally, visual interference from boat structural members may play an important role in scanning patterns as might helm station location. Investigations into this area could yield productive studies regarding potentially important visual factors related to the boat collision type accident.

REFERENCES

- Dykstra, D. R. "Effect of Head-Mounted Visual Monitoring Equipment on Operator Behavior." Technical Report, Dept. of Industrial and Operations Engineering, The University of Michigan, 1977.
- Gatchell, S. M. "Boat Operators' Visual Behavior Patterns." Paper presented to the Second Conference on Eye Movements and Psychological Processes, Monterey, Calif., February 1977.
- Gordon, D. A. and Michaels, R. M. "Static and Dynamic Visual Fields in Vehicular Guidance." Highway Research Record, 84:1-15, 1965.
- Kaluger, N. A. and Smith, G. L., Jr. "Driver Eye-Movement Patterns Under Conditions of Prolonged Driving and Sleep Deprivation." Highway Research Record, No. 336:92-106, 1970.
- MacNeill, R., et al. Recreational Boat Safety Collision Research - Phase I, Vol. II, Collision Accident Investigations for 1974 Season. Final Report for the U.S. Coast Guard by Wyle Laboratories, 1974. NTS No. AD A015 820.
- MacNeill, R., Stiehl, C., Cohen, S., and Doll, T. Recreational Boat Safety Collision Research - Phase II, Vol. I - Problems Definition; Safety Enhancement Concepts. Final Report for the U.S. Coast Guard by Wyle Laboratories, 1976.
- McDowell, E.D. An Exploratory Investigation of the Stochastic Nature of the Driver's Eye and Control Movements and Their Relationship to the Roadway Geometry, Unpublished doctoral thesis, Ohio State University, Columbus, Ohio, 1975.
- Miller, J. M. Human Factors Applications in Boating Safety. Final Report for the U.S. Coast Guard by The University of Michigan, NTIS No. AD-781-205, 1973.
- Mourant, R. R. and Rockwell, T. H. "Strategies of Visual Search by Novice and Experienced Drivers." Human Factors, 14(4):324-335, August 1972.
- Whalen, J. T., Rockwell, T. H. and Mourant, R. R. A Pilot Study of Drivers' Eye Movements. Ohio State University, Columbus, Ohio, April, 1968.
- Zell, J. K., Rockwell, T. H. and Mourant, R. R. Visual Search in Driving as a Function of Experience. Ohio State University Driving Research Laboratory, Columbus, Ohio, 1969.

APPENDIX A

PHYSICAL DIMENSIONS AND PERSONAL EXPERIENCE  
INFORMATION FORMS

SUBJECT \_\_\_\_\_ 73 \_\_\_\_\_ AGE \_\_\_\_\_ DATE \_\_\_\_\_

## MEASUREMENTS

SITTING HEIGHT \_\_\_\_\_ 32 3/8" \_\_\_\_\_

SEATED EYE HEIGHT \_\_\_\_\_ 28 3/8" \_\_\_\_\_

SHOULDER HEIGHT \_\_\_\_\_ 21 1/2" \_\_\_\_\_

ELBOW REST HEIGHT \_\_\_\_\_ 7 3/8" \_\_\_\_\_

SHOULDER WIDTH \_\_\_\_\_ 16 3/4" \_\_\_\_\_

HIP WIDTH \_\_\_\_\_ ----- \_\_\_\_\_

UPPER ARM LENGTH \_\_\_\_\_ 13 5/8" \_\_\_\_\_

LOWER ARM LENGTH \_\_\_\_\_ 17 5/8" \_\_\_\_\_

POPLITEAL LENGTH \_\_\_\_\_ 15 3/4" \_\_\_\_\_

POPLITEAL HEIGHT \_\_\_\_\_ 17 3/4" \_\_\_\_\_

KNEE HEIGHT \_\_\_\_\_ 20 3/4" \_\_\_\_\_

MOUTH TO EYE HEIGHT \_\_\_\_\_ 2 3/8" \_\_\_\_\_

MOUTH TO TOP-OF-HEAD HEIGHT \_\_\_\_\_ 6 1/2" \_\_\_\_\_

HEAD CIRCUMFERENCE \_\_\_\_\_ 9 5/8" \_\_\_\_\_

STANDING HEIGHT \_\_\_\_\_ 64 1/4" \_\_\_\_\_

WEIGHT \_\_\_\_\_ 132 lb. \_\_\_\_\_

COMMENTS \_\_\_\_\_

\_\_\_\_\_

59

SUBJECT \_\_\_\_\_ AGE \_\_\_\_\_ DATE 8/11/76

MEASUREMENTS

SITTING HEIGHT 35 1/4"

SEATED EYE HEIGHT 31 1/2"

SHOULDER HEIGHT 24 1/2"

ELBOW REST HEIGHT 9"

SHOULDER WIDTH 17 3/8"

HIP WIDTH ---

UPPER ARM LENGTH 14 1/2"

LOWER ARM LENGTH 18"

POPLITEAL LENGTH 17 1/2"

POPLITEAL HEIGHT 17 1/2"

KNEE HEIGHT 22 1/2"

MOUTH TO EYE HEIGHT 2 3/4"

MOUTH TO TOP-OF-HEAD HEIGHT 7 1/4"

HEAD CIRCUMFERENCE 11"

STANDING HEIGHT 68 1/2"

WEIGHT 155 lbs.

COMMENTS tennis shoes on

75

SUBJECT \_\_\_\_\_ AGE \_\_\_\_\_ DATE \_\_\_\_\_

MEASUREMENTS

SITTING HEIGHT 36"

SEATED EYE HEIGHT 31 1/2"

SHOULDER HEIGHT 26"

ELBOW REST HEIGHT 11"

SHOULDER WIDTH 18"

HIP WIDTH ---

UPPER ARM LENGTH 14 1/2"

LOWER ARM LENGTH 18 3/4"

POPLITEAL LENGTH 17 1/4"

POPLITEAL HEIGHT 18"

KNEE HEIGHT 23"

MOUTH TO EYE HEIGHT 2 5/8"

MOUTH TO TOP-OF-HEAD HEIGHT 7 7/8"

HEAD CIRCUMFERENCE 10 1/4"

STANDING HEIGHT 72 1/4"

WEIGHT 175 lb.

COMMENTS \_\_\_\_\_  
\_\_\_\_\_

31

76

SUBJECT \_\_\_\_\_ AGE \_\_\_\_\_ DATE \_\_\_\_\_

MEASUREMENTSSITTING HEIGHT 36"SEATED EYE HEIGHT 30 1/2"SHOULDER HEIGHT 25 1/2"ELBOW REST HEIGHT 10"SHOULDER WIDTH 19"HIP WIDTH ---UPPER ARM LENGTH 15 1/2"LOWER ARM LENGTH 19"POPLITEAL LENGTH 18 1/4"POPLITEAL HEIGHT 18"KNEE HEIGHT 23"MOUTH TO EYE HEIGHT 3"MOUTH TO TOP-OF-HEAD HEIGHT 7"HEAD CIRCUMFERENCE 10 1/2"STANDING HEIGHT 6' 0"WEIGHT 186 lb.

COMMENTS \_\_\_\_\_

THE UNIVERSITY OF MICHIGAN<sup>77</sup> • COLLEGE OF ENGINEERING  
DEPARTMENT OF INDUSTRIAL AND OPERATIONS ENGINEERING  
2260 G. G. BROWN LABORATORY  
ANN ARBOR, MICHIGAN 48105

September 5, 1975

Dear Boater:

Thank you very much for responding to our ad for experienced boaters.

Attached are copies of the boater experience questionnaire. An extra copy has been included because many boaters indicated that they had friends or relatives who were also experienced boaters and could fill out our questionnaire, regardless of whether or not they intend to participate as subjects. Please fill out one set of questionnaires yourself and give the extra set to another boater if you like.

As indicated in our phone conversation, each subject would participate in several half-day sessions and be paid \$5/hour. Your tasks would involve driving an I-O Runabout type boat under some typical operating circumstances.

Even if you choose not to volunteer as a subject, your completion and return of the Boating Experience Questionnaire would be appreciated.

The response to our ad for boaters has been excellent. Since this is only the first of several studies which will be conducted over the next few years, we hope that we can eventually involve the remainder of you who are not selected for this first research effort.

Again, let me thank you for responding to our ad.

Sincerely,

*James M. Miller*

James M. Miller, Ph.D.  
Assistant Professor

*Susanne Gatchell*

Susanne Gatchell  
Graduate Student

/eb  
Enclosures

BOATING EXPERIENCE QUESTIONNAIRE

Instructions for filling out this questionnaire:

1. All responses will be confidential.
2. Use either a pen or pencil to respond to the questions.
3. Check (✓) the appropriate response box or write in your answer.
4. If you would like to write a longer response than space allows, use the back side of the sheet. When continuing your response on the back side, please refer to the question number that you are answering.
5. If uncertainties arise, please call me collect:

Sue Gatchell  
Days: 1-763-2189  
Evenings and Weekends: 1-429-9528

6. Return the completed questionnaire to:

Susanne Gatchell  
2260 G.G. Brown Lab  
Industrial and Operations Engineering  
The University of Michigan  
Ann Arbor, Michigan 48104

Thank you.

(84)

SUBJECT SCHEDULING FORM

I would like to volunteer to be a subject for the University of Michigan's Boat Operator Behavior Study to be conducted in the late summer 1976. I understand that all written, verbal and performance information about me will be kept confidential and used exclusively by the University and that I may withdraw from the study at any time.

\_\_\_\_\_  
Subject's Name

\_\_\_\_\_  
Date

Hours available for study (Between 8:00 AM to 8:00 PM)

|           | <u>Hours Available</u> |
|-----------|------------------------|
| Monday    | from _____ to _____    |
| Tuesday   | from _____ to _____    |
| Wednesday | from _____ to _____    |
| Thursday  | from _____ to _____    |
| Friday    | from _____ to _____    |
| Saturday  | from _____ to _____    |
| Sunday    | from _____ to _____    |

Remarks:

7

(85)

## BOATING EXPERIENCE QUESTIONNAIRE

80

NAME \_\_\_\_\_

ADDRESS \_\_\_\_\_

ZIP CODE \_\_\_\_\_

TELEPHONE NUMBER \_\_\_\_\_

SEX: Male  Female  AGE \_\_\_\_\_

1. APPROXIMATE HEIGHT \_\_\_\_\_ (inches)
2. APPROXIMATE WEIGHT \_\_\_\_\_ (pounds)
3. TYPE OF EMPLOYMENT (job description or job title) \_\_\_\_\_
- 
- 4a. DO YOU WEAR PRESCRIPTION GLASSES WHILE DRIVING A BOAT? (please check)  
 Always  Frequently  Infrequently  Never
- b. DO YOU WEAR CONTACT LENSES WHILE DRIVING A BOAT? (please check)  
 Always  Frequently  Infrequently  Never
- c. DO YOU WEAR NON-PRESCRIPTION SUNGLASSES WHILE DRIVING A BOAT? (please check)  
 Always  Frequently  Infrequently  Never
5. CAN YOU SWIM?  
 No  Beginning Level  Intermediate Level  Advanced Level
6. HOW OFTEN DO YOU WEAR A LIFEJACKET WHILE BOATING? (please check)  
 Always  Occasionally  Only in Rough Conditions  Never
- 7a. HOW MANY YEARS HAVE YOU BEEN OPERATING MOTORBOATS? (please check)  
 Less than 1 yr.  1-3 yrs.  3-5 yrs.  5-10 yrs.
- b. HOW MANY YEARS HAVE YOU BEEN OPERATING SAILBOATS? (please check)  
 Never  Less than 1 yr.  1-3 yrs.  3-5 yrs.   
 5-10 yrs.  10-15 yrs.  15-20 yrs.  Over 20 yrs.
8. DURING THE BOATING SEASON, APPROXIMATELY HOW MUCH AVERAGE TIME PER WEEK DO YOU SPEND DRIVING A MOTOR BOAT? (please check):  
 Less than 1 hr.  1-2 hrs.  3-5 hrs.  6-10 hrs.   
 11-20 hrs.  21-30 hrs.  Over 30 hrs.

9. WHAT TYPES OF BOATS HAVE YOU OPERATED FREQUENTLY DURING THE PAST 5 YEARS?  
LIST EACH BOAT BELOW:

A. BOAT #1: Used most frequently in last 5 years.

a) TYPE OF BOAT (please check)

Open Motorboat  Cabin Motorboat  Sailboat   
Rowboat  Canoe  Other (specify) \_\_\_\_\_

b) MANUFACTURER \_\_\_\_\_

c) LENGTH (please check)

Less than 13 ft.  13-15 ft.  15-17 ft.  17-19 ft.   
19-21 ft.  21-25 ft.  26-30 ft.  Over 30 ft.

d) APPROXIMATELY HOW MUCH TIME PER WEEK DID YOU OPERATE THIS BOAT?  
(please check):

Less than 1 hr.  1-3 hrs.  3-5 hrs.  5-10 hrs.   
10-20 hrs.  20-30 hrs.  Over 30 hrs.

e) WHAT WAS THE PRIMARY USE FOR THIS BOAT? (please check)

Cruising  Waterskiing  Fishing  Other (specify) \_\_\_\_\_

f) DO YOU PRESENTLY OWN THIS BOAT? (please check):

Yes  No

B. BOAT #2:

a) TYPE OF BOAT (please check)

Open Motorboat  Cabin Motorboat  Sailboat   
Rowboat  Canoe  Other (specify) \_\_\_\_\_

b) MANUFACTURER \_\_\_\_\_

c) LENGTH (please check):

Less than 13 ft.  13-15 ft.  15-17 ft.  17-19 ft.   
19-21 ft.  21-25 ft.  25-30 ft.  Over 30 ft.

d) APPROXIMATELY HOW MUCH TIME PER WEEK DID YOU OPERATE THIS BOAT?  
(please check):

Less than 1 hr.  1-2 hrs.  3-5 hrs.  6-10 hrs.   
11-20 hrs.  21-30 hrs.  Over 30 hrs.

67 957.

e) WHAT WAS THE PRIMARY USE FOR THIS BOAT? (please check)

Cruising  Waterskiing  Fishing  Other (specify) \_\_\_\_\_

f) DO YOU PRESENTLY OWN THIS BOAT? (please check)

Yes  No

C. BOAT #3:

a) TYPE OF BOAT (please check)

Open Motorboat  Cabin Motorboat  Sailboat

Rowboat  Canoe  Other (specify) \_\_\_\_\_

b) MANUFACTURER \_\_\_\_\_

c) LENGTH (please check)

Less than 13 ft.  13-15 ft.  15-17 ft.  17-19 ft.

19-21 ft.  21-25 ft.  25-30 ft.  Over 30 ft.

d) APPROXIMATELY HOW MUCH TIME PER WEEK DID YOU OPERATE THIS BOAT? (please check)

Less than 1 hr.  1-3 hrs.  3-5 hrs.  5-10 hrs.

10-20 hrs.  20-30 hrs.  Over 30 hrs.

e) WHAT WAS THE PRIMARY USE FOR THIS BOAT? (please check)

Cruising  Waterskiing  Fishing  Other (specify) \_\_\_\_\_

f) DO YOU PRESENTLY OWN THIS BOAT? (please check)

Yes  No

10. WHAT TYPES OF INSTRUMENTS, GAUGES, OR INDICATORS DO YOU HAVE ON THE BOAT WHICH YOU NOW DRIVE MOST FREQUENTLY? (please check)

Speedometer  Tachometer  Ammeter  Oil Pressure Ind.

Fuel Gauge  Compass  Engine Hour Meter  Trim Indicator

Engine Temperature  Gas Detector  Depth Sounder

Others (specify) \_\_\_\_\_

11. WHERE DO YOU DO MOST OF YOUR BOATING (i.e., Lake Erie?) \_\_\_\_\_

\_\_\_\_\_

12. WHERE DO YOU KEEP YOUR BOAT(S)? (please check)

Marina  At Home on Trailer  At Home On Water

Other (specify) \_\_\_\_\_

13. DO YOU EVER TRAILER YOUR BOAT(S)? (please check)

Yes  No

IF YES, DO YOU ENCOUNTER PROBLEMS WITH TRAILERING YOUR BOAT, EITHER PULLING, LOADING, OR UNLOADING YOUR BOAT? (please check)

Yes  No

IF YES, PLEASE EXPLAIN \_\_\_\_\_

\_\_\_\_\_  
\_\_\_\_\_

14. HAVE YOU TAKEN ANY BOATING COURSES? (please check)

Yes  No

IF YES, WHICH ONES? (please check)

USCG Auxiliary  U.S. Power Squadron  American Red Cross

Michigan State Courses  Others (specify) \_\_\_\_\_

\_\_\_\_\_

15. HAVE YOU EVER HAD A BOAT SAFETY CHECK BY THE COAST GUARD AUXILIARY OR OTHER AUTHORITY? (please check)

Yes  No

16. HAVE YOU EVER WITNESSED A BOATING ACCIDENT?

Yes  No

IF YES, PLEASE ANSWER THE FOLLOWING QUESTIONS:

A. WHERE DID THE ACCIDENT OCCUR? \_\_\_\_\_

\_\_\_\_\_

B. WHAT TYPES OF BOATS WERE INVOLVED (include approximate lengths?) \_\_\_\_\_

\_\_\_\_\_

\_\_\_\_\_

\_\_\_\_\_

89



Environmental Conditions Sheet

Date \_\_\_\_\_

(To be filled out for each test run)

## 1. Detroit Weather Report:

- a. Sky \_\_\_\_\_ g. Time \_\_\_\_\_
- b. Temperature \_\_\_\_\_
- c. Humidity \_\_\_\_\_
- d. Wind Speed \_\_\_\_\_
- e. Wind Direction \_\_\_\_\_
- f. Barometer Reading \_\_\_\_\_

## 2. Weather (as reported by observer on the boat):

a. Percent of Cloud Cover \_\_\_\_\_

## b. Conditions

- |               |         |
|---------------|---------|
| 1. Cloudless  | 2. Fog  |
| 3. Overcast   | 4. Rain |
| 5. Light Haze | 6. Hazy |

## 3. Water Conditions

- |                   |               |
|-------------------|---------------|
| Ia. Calm          | b. Choppy     |
| c. Rough          | d. Very Rough |
| e. Strong Current |               |

II. Height of Waves \_\_\_\_\_

## 4. Visibility

- I. a. Good
- b. Fair
- c. Poor

II. Number of Miles \_\_\_\_\_

## 5. Wind (as reported by observer on the boat):

## I. Amount

- a. None
- b. Light (0-6 m.p.h.)

91 977.

c. Moderate (7-14 m.p.h.)

d. Strong (15-25 m.p.h.)

e. Storm (greater than 25 m.p.h.)

II. Direction

a. North

b. Northeast

c. East

d. Southeast

e. South

f. Southwest

g. West

h. Northwest

APPENDIX B

ADDITIONAL FIGURES

(73)

AD-A041 371

MICHIGAN UNIV ANN ARBOR DEPT OF INDUSTRIAL AND OPERA--ETC F/G 6/19  
THE VISUAL BEHAVIOR OF RECREATIONAL BOAT OPERATORS AND ITS RELA--ETC(U)  
MAY 77 J M MILLER, D R DYKSTRA, S M GATCHELL DOT-CG-61098-A  
USCG-D-31-77 NL

UNCLASSIFIED

2 OF 2

AD  
A041371

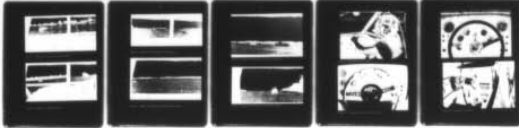

END

DATE

FILMED

7-77



Figure 1: Segment #3, Centering in Buoyed Channel



Figure 2: Segment #8, Right Wide Turn



Figure 3: Segment #9, Following Left Land Contour



Figure 4: Segment #14, Heading to Visual Reference Point

73



Figure 5: Segment #15, Maneuvering Through Intersection



Figure 6: Segment #16, Centering in Land Bound Channel



Figure 7: Helmeted Subject at Helm

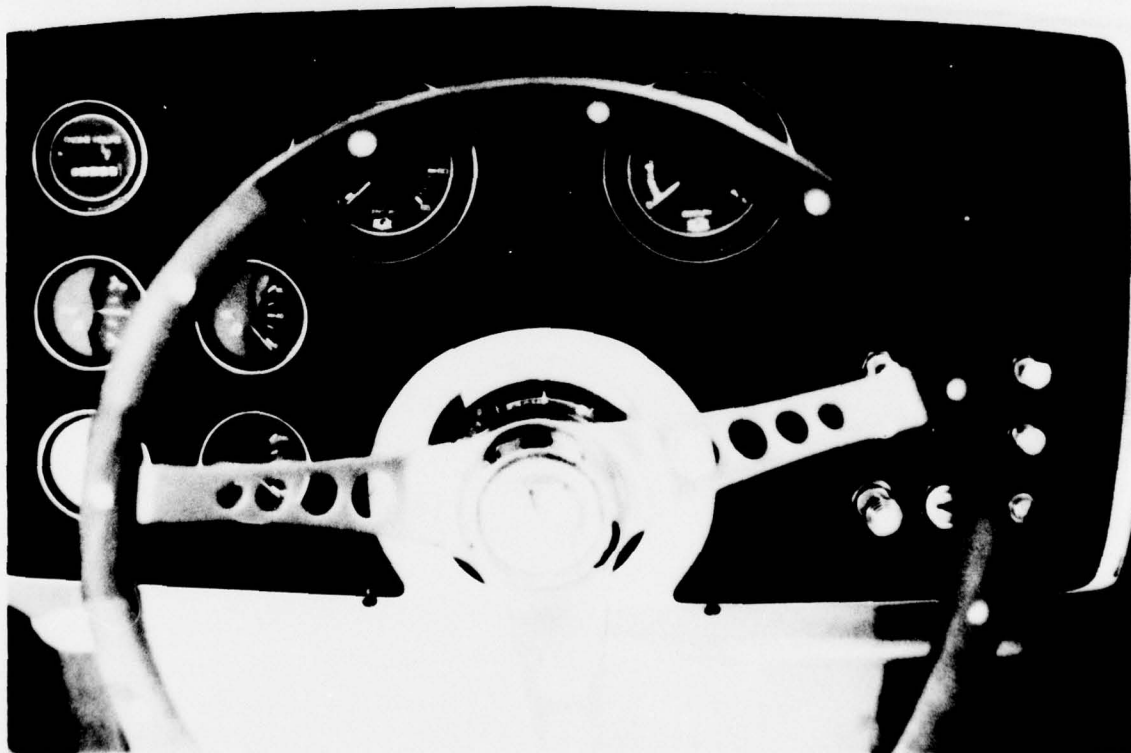

Figure 8: Instrument Panel Before Modification

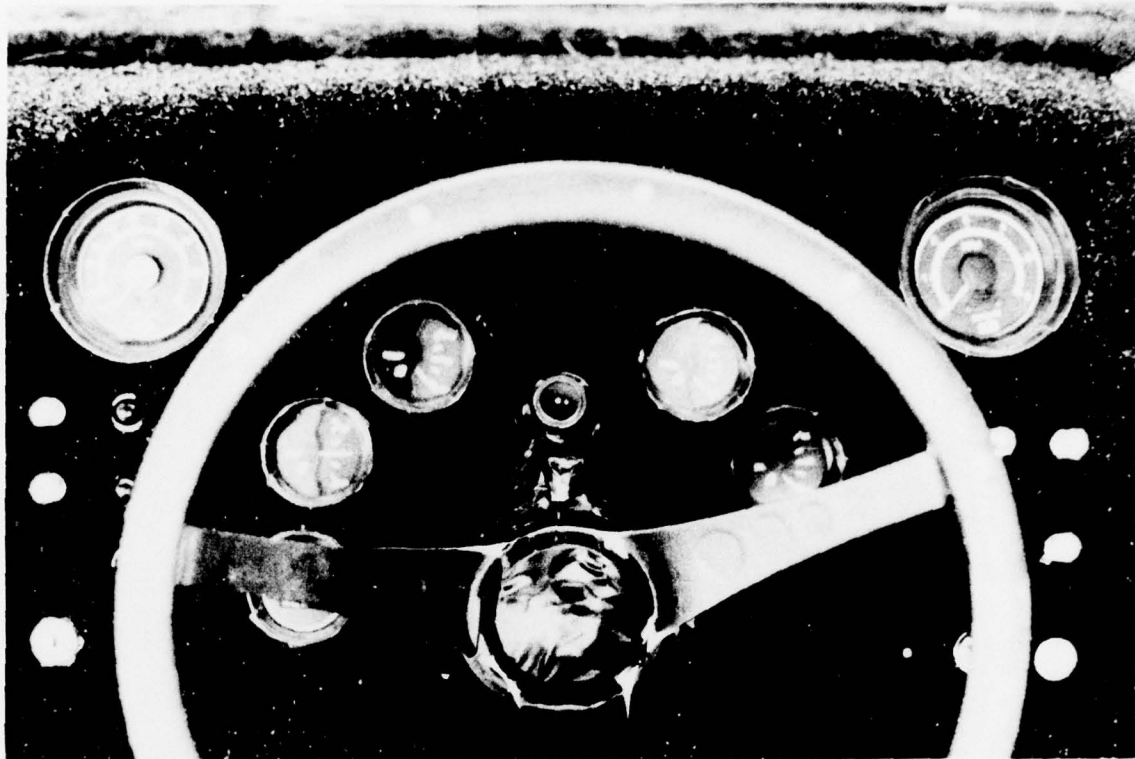

Figure 9: Instrument Panel After Modification

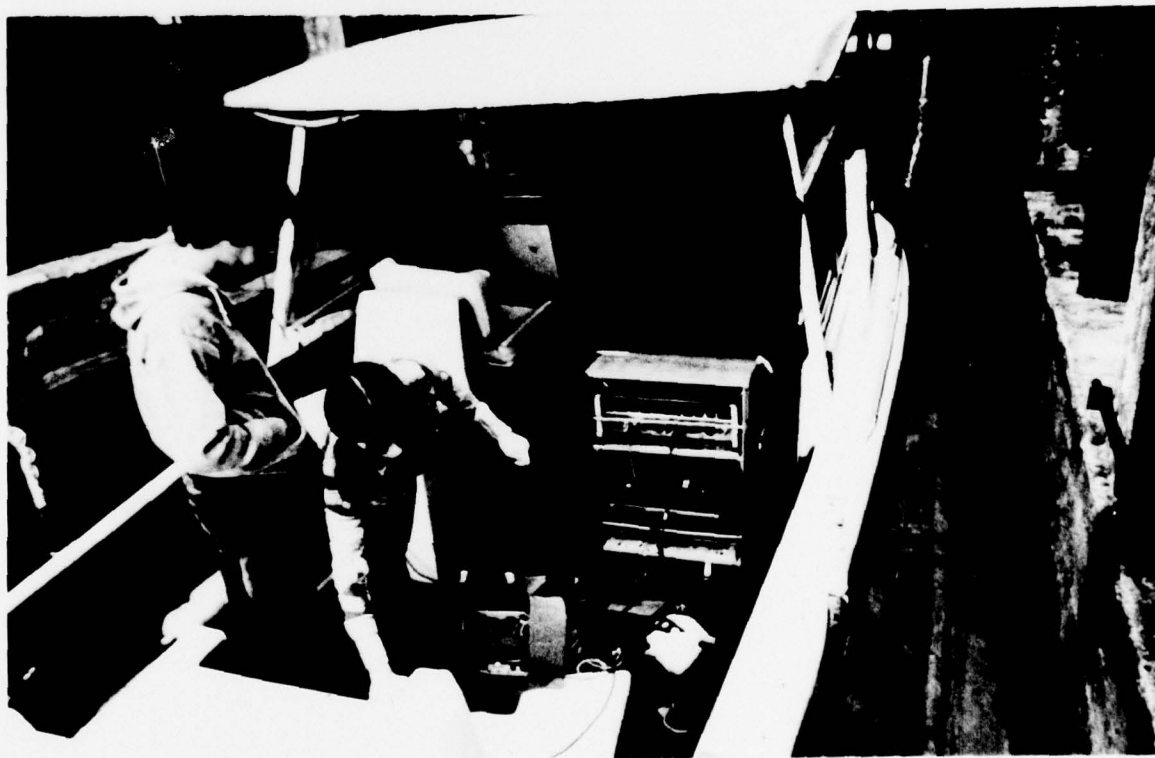

Figure 10: Equipment Preparation.