

AD-A041 422

NAVAL RESEARCH LAB WASHINGTON D C
A CIRCULAR TRANSDUCER ARRAY FOR ULTRASONIC INSPECTION OF PLATES--ETC(U)
MAY 77 K E SIMMONDS, S D HART

F/G 14/2

UNCLASSIFIED

NRL-8119

NL

| OF |

AD
A041422



END
DATE
FILMED
8 - 77

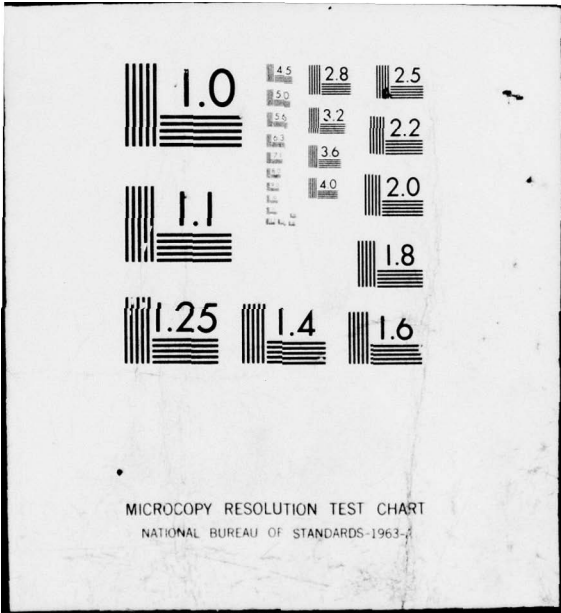

MICROCOPY RESOLUTION TEST CHART
NATIONAL BUREAU OF STANDARDS-1963-A

12

NRL Report 8119

J

A Circular Transducer Array for Ultrasonic Inspection of Plates and Sheets

K. E. SIMMONDS AND S. D. HART

*Mechanics of Materials Branch
Ocean Technology Division*

AD A 041 422

May 20, 1977



NAVAL RESEARCH LABORATORY
Washington, D.C.

DDC
RECEIVED
JUL 11 1977
RECEIVED
A

AD NO. _____
DDC FILE COPY

Approved for public release; distribution unlimited.

REPORT DOCUMENTATION PAGE		READ INSTRUCTIONS BEFORE COMPLETING FORM
1. REPORT NUMBER NRL Report 8119	2. GOVT ACCESSION NO.	3. RECIPIENT'S CATALOG NUMBER
4. TITLE (and Subtitle) A CIRCULAR TRANSDUCER ARRAY FOR ULTRASONIC INSPECTION OF PLATES AND SHEETS	5. TYPE OF REPORT & PERIOD COVERED Final report, on one phase of a continuing NRL Problem.	6. PERFORMING ORG. REPORT NUMBER
7. AUTHOR(s) K. E. Simmonds and S. D. Hart	8. CONTRACT OR GRANT NUMBER(s)	
9. PERFORMING ORGANIZATION NAME AND ADDRESS Naval Research Laboratory Washington, D.C. 20375	10. PROGRAM ELEMENT, PROJECT, TASK AREA & WORK UNIT NUMBERS NRL Problem F03-52 SF54-591-504, 62761N	
11. CONTROLLING OFFICE NAME AND ADDRESS Naval Sea Systems Command Department of the Navy Washington, D.C. 20362	12. REPORT DATE May 20, 1977	13. NUMBER OF PAGES 18
14. MONITORING AGENCY NAME & ADDRESS (if different from Controlling Office) 12 19p.	15. SECURITY CLASS. (of this report) Unclassified	15a. DECLASSIFICATION/DOWNGRADING SCHEDULE
16. DISTRIBUTION STATEMENT (of this Report) Approved for public release; distribution unlimited. 16) F54571 12) SF54591504		
17. DISTRIBUTION STATEMENT (of the abstract entered in Block 20, if different from Report)		
18. SUPPLEMENTARY NOTES		
19. KEY WORDS (Continue on reverse side if necessary and identify by block number) Ultrasonics Reliability Inspection Transducers Arrays Signal processing Flaws		
20. ABSTRACT (Continue on reverse side if necessary and identify by block number) Several years ago, in an effort to increase the reliability of detection of randomly oriented cracks, a rotating transducer head was designed to be mounted on the carriage of an automatic ultrasonic plate inspection system. The weight of the rather sturdy motor needed to rotate this device made it impractical, but the principle was sound. Recent developments in the miniaturization of electronic circuitry have made possible a substitute for rotation, namely, sequential operation of a ring of transducers. An experimental model has been built. This report describes its performance. It was not intended that it give complete coverage, that is, detect flaws of all orientations. The basis for choice of design parameters for complete (Continued)		

DD FORM 1473
1 JAN 73EDITION OF 1 NOV 65 IS OBSOLETE
S/N 0102-LF-014-6601

SECURITY CLASSIFICATION OF THIS PAGE (When Data Entered)

251 950

13

20. Abstract (Continued):

coverage is discussed. Since the transducers and their attendant circuits are discrete, various modes of operation are possible, such as one transmitting and all receiving, all transmitting and receiving, and one transmitting and receiving alone. With the assistance of computer control, computer evaluation, and computer graphics the circular transducer array could become a powerful tool for characterizing and evaluating flaws.



CLASSIFICATION FOR

CLASSIFIED BY: [Handwritten Signature]

W/PS Section
Buff Section

UNANNOUNCED
JUSTIFICATION

BY
DISTRIBUTION AVAILABILITY CODES

Dist.	AVAIL.	NO. OF	SPECIAL
A			

CONTENTS

INTRODUCTION	1
TRANSDUCER ARRAY	1
ELECTRONIC CIRCUITS	3
ARRAY PERFORMANCE	8
DISCUSSION OF ANGULAR DISTRIBUTION OF SENSITIVITY	12
COMPUTER-AIDED FLAW EVALUATION	14
CONCLUSIONS AND RECOMMENDATIONS	14
ACKNOWLEDGMENTS	15

A CIRCULAR TRANSDUCER ARRAY FOR ULTRASONIC INSPECTION OF PLATES AND SHEETS

INTRODUCTION

Plate and sheet products are usually inspected only for laminar flaws using normal-incidence ultrasonics. This procedure is totally inadequate for welds, which often contain serious flaws of other orientation, such as inclusions, cracks, lack of fusion, and incomplete penetration. Although such flaws tend to be oriented either normal to or parallel to the weld axis, intermediate orientations also occur. Randomly oriented flaws are even occasionally found in plate products.

The detection of randomly oriented, planar flaws by either ultrasonics or radiography is limited by the availability of angular aspects for impinging radiation relative to the plane of the flaw. For a high level of confidence, an object must be inspected using many different angles, a tedious, time-consuming, and hence costly process. To avoid this, it was proposed several years ago* that a rotating-transducer shear-wave array attached to standard automatic scanning equipment be used. Experiments with this arrangement showed that the principle was sound but mechanically impractical. The progress in electronics in recent years led to consideration of the possibility of accomplishing the effect of rotation by sequentially operating a ring of individual stationary transducers. This report presents results of this development.

TRANSDUCER ARRAY

An ideal array would consist of a large number of transducers in a circle, all angled to produce shear waves at the desired angle in the plate. Difficulties in accomplishing the ideal are both economic and physical. A large number of elements would be costly to buy as well as to mount, and great care would be required to prevent coupling between transducers. From the point of view of detection only, the intercoupling might not be serious. However it would interfere with other applications, such as flaw analysis, in which it would be desirable to operate the individual elements independently.

The present compromise shown in Fig. 1 employs seven transducers in a circle, angled to produce approximately 45° shear waves in steel in an immersion system. In addition, a transducer at the center of the ring, oriented at normal incidence, produces compressional waves to provide a top-surface echo which serves as a trigger for the gating circuits in the flaw alarm system and as a detector of laminar flaws. All transducers were 3/4-inch-diameter (2-cm-diameter) 5-MHz lithium sulfate discs mounted in special housings. Transducer capacitance was electrically tuned to 5 MHz. Work with this system showed that a center transducer with a smaller diameter would be preferable, since a lower signal strength would minimize both the number of multiple-thickness echoes and the effect of slight surface irregularities in the plate.

Note: Manuscript submitted March 18, 1977.

*S.D. Hart and L.C. Cardinal, "A New Technique for Ultrasonic Inspection of Sheet Steel," Report of NRL Progress, Mar. 1964, p. 4.

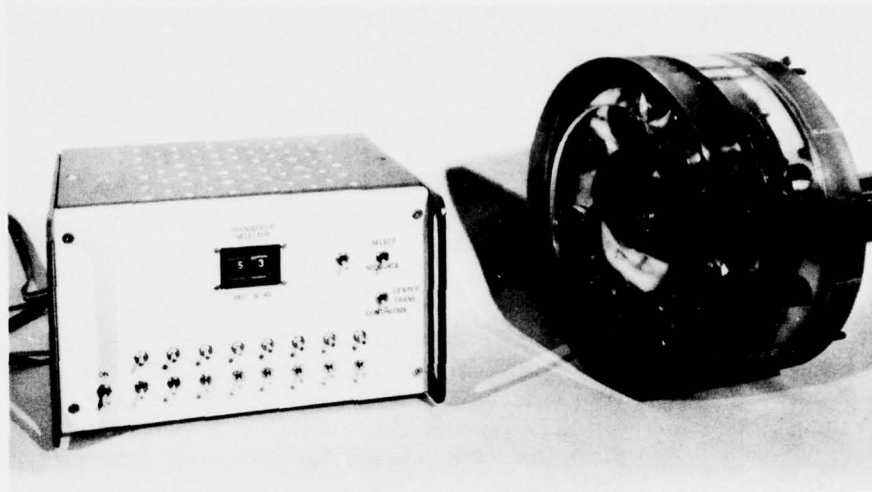

Fig. 1—Transducer array and its associated control panel, which contains the electronics for sequential operation

The transducers are mounted in a Lucite housing along with a pulser and receiver for each transducer. The diameter of the transducer ring (locus of centers) is 5 inches (13 cm). The ultrasonic beams from all transducers converge at a point 7.5 inches (19 cm) below the center of the ring. In the presence of a plate the ray paths would be as sketched in Fig. 2 for one transducer. By raising or lowering the array the point of convergence could be placed anywhere in the thickness of the plate. From Fig. 2 a simple relationship can be derived between the height of the array H , the radius of the transducer circle R , the thickness of the plate T , the incidence angle θ_L , the refraction angle θ_S in the plate, and the number of half bounces in the plate n :

$$H = \frac{R - nT \tan \theta_S}{\tan \theta_L} \quad (1)$$

where $\theta_S = \sin^{-1} [(C_S/C_L) \sin \theta_L]$, in which C_S and C_L are the shear velocity in the plate and longitudinal velocity in the water. Use of Eq. (1) is illustrated in Fig. 3, which gives the height of the array above the surface of the plate for beam convergence at the bottom ($n = 1$), midthickness ($n = 1.5$), and the top ($n = 2$). Actually beam spread provides more coverage in depth than is indicated by the ray diagrams.

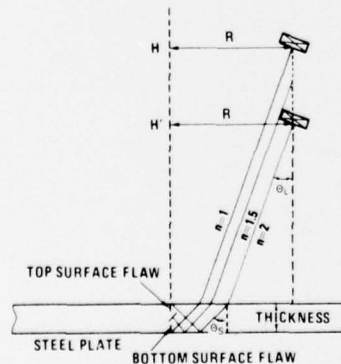

Fig. 2—Ray paths of ultrasound with the array at various distances above a plate. The paths labeled $n = 1$, $n = 1.5$, and $n = 2$ respectively represent 1/2 bounce (point of convergence of the beams is at the bottom of the plate), 3/4 bounce (point of convergence is at the center) and 1 bounce (point of convergence is at the top).

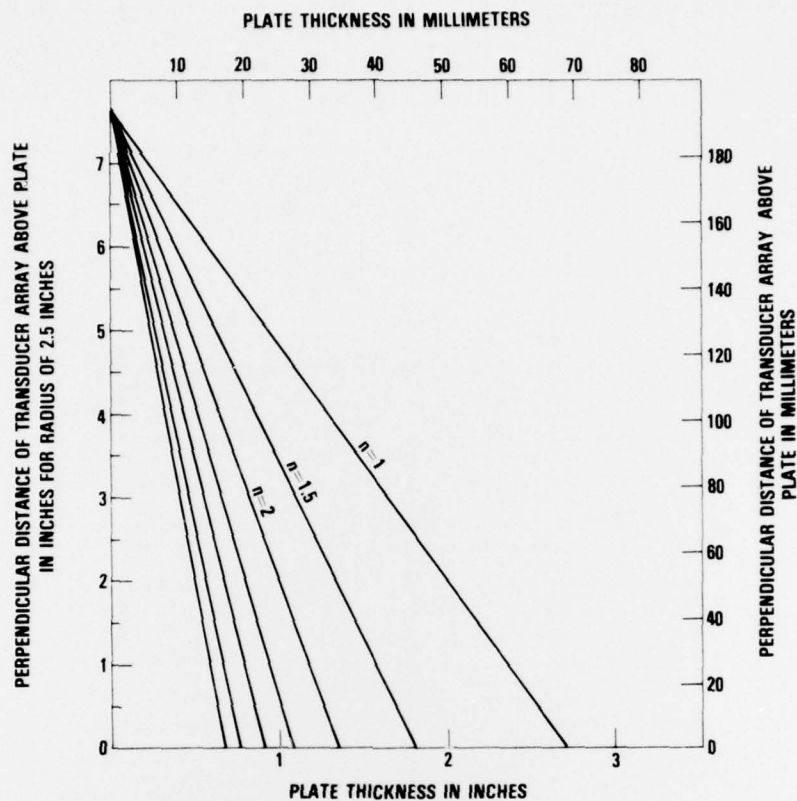

Fig. 3—Plate thickness in relation to the distance of the array above the plate as a function of bounce number n (which locates the point of convergence in the plate, as shown in Fig. 2)

ELECTRONIC CIRCUITS

The electronic circuitry is designed to be used with a standard ultrasonic test instrument which provides timing signals and displays information in the form of the usual A-scan. A clock signal is obtained from the early sync of the ultrasonic test instrument, as shown in Fig. 4. This signal passes through a pulse-shaping circuit which converts the sync pulses to 5-volt logic pulses, by circuitry shown in Fig. 5. The clock signal controls the rate at which the transducers are pulsed and sequenced. Before the clock signal reaches the pulsers, the frequency is divided down by the combination of an up-down counter and a BCD decoder as shown in Fig. 6. These, in combination with logic gates and a BCD switch, permit control of the sequence of pulsing and receiving. By means of this logic circuitry, the following modes of operation are possible: sequentially pulsing the transducers with all preamplifiers continuously receiving, sequentially pulsing each transducer in turn with only its associated preamplifier active, and pulsing the center transducer on every clock cycle, in sequence with the others, inactive, or in receiving mode only.

Each transducer is shock excited by the sharp voltage transition of a condenser discharge by a pulser, diagrammed in Fig. 7. (Pulsers were small, encapsulated units supplied by Sonic Instruments, Trenton, New Jersey.) The pulser units, one for each transducer, are mounted

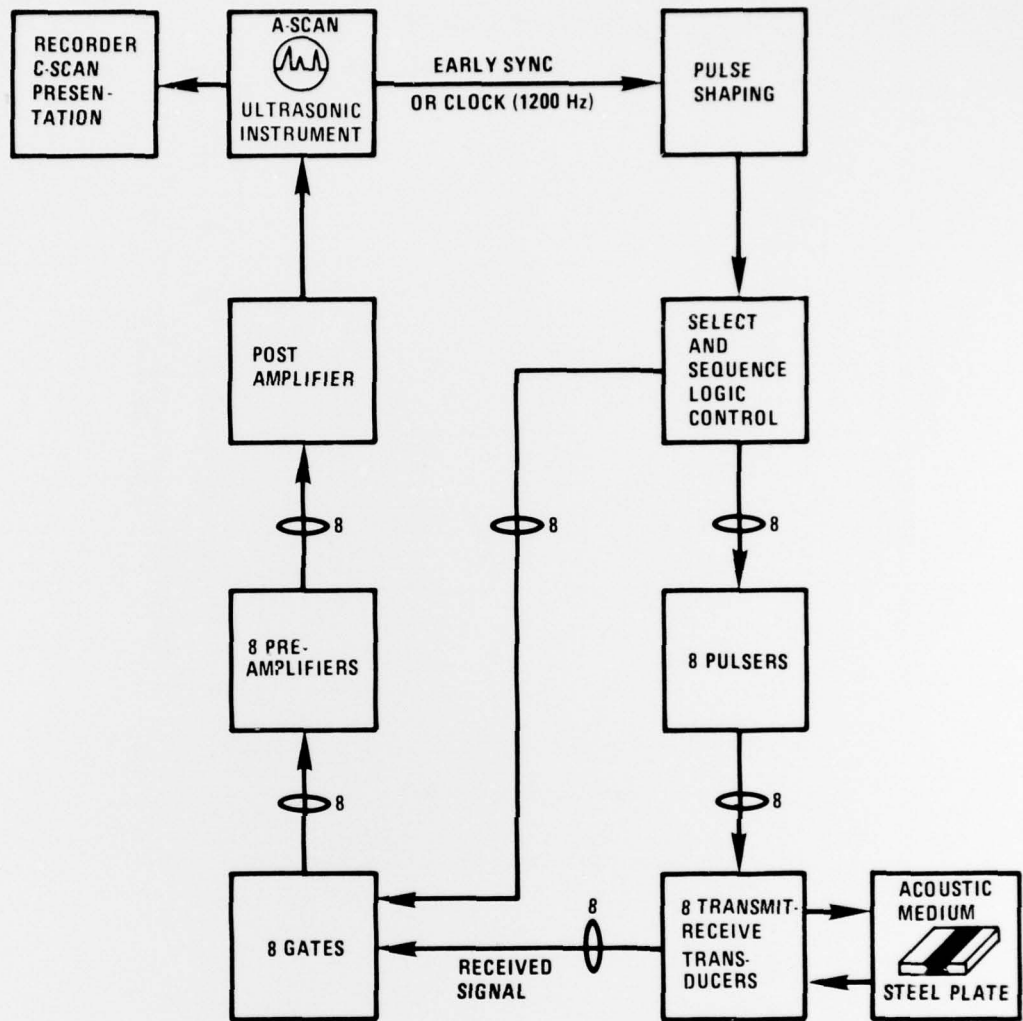

Fig. 4—System block diagram. The numbered rings indicate the number of control lines and return signal paths.

on a copper-backed circuit board as close as possible to the transducers. Also mounted on the circuit board are an analog gate, a preamplifier for each transducer, and a postamplifier, which feeds the combined outputs of the preamplifiers to the receiver input of the commercial ultrasonic instrument (Fig. 8). The gate circuit is detailed in Fig. 9.

In most commercial instruments a flaw alarm circuit is provided. This circuit is armed either by a signal from the internal clock or by the first echo after some fixed delay. In an immersion system this would normally be an echo from the top or front of a piece being inspected (front surface, or interface gating). In the array the primary purpose of the center transducer is to provide a top-surface echo as a trigger to arm the flaw alarm circuit.

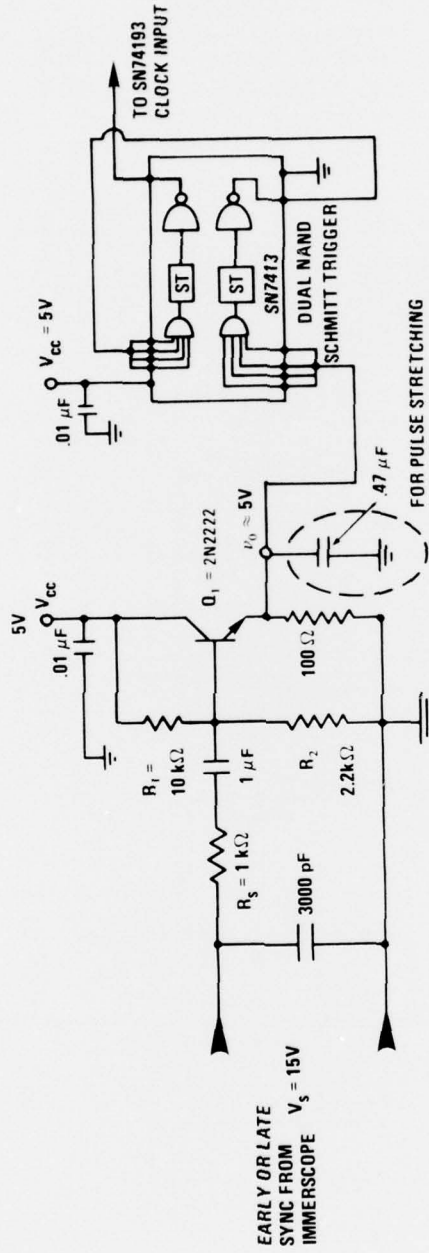

Fig. 5—Clock pulse shaper used to shape and limit sync signals from the ultrasonic test instrument such that they are compatible with the integrated circuits

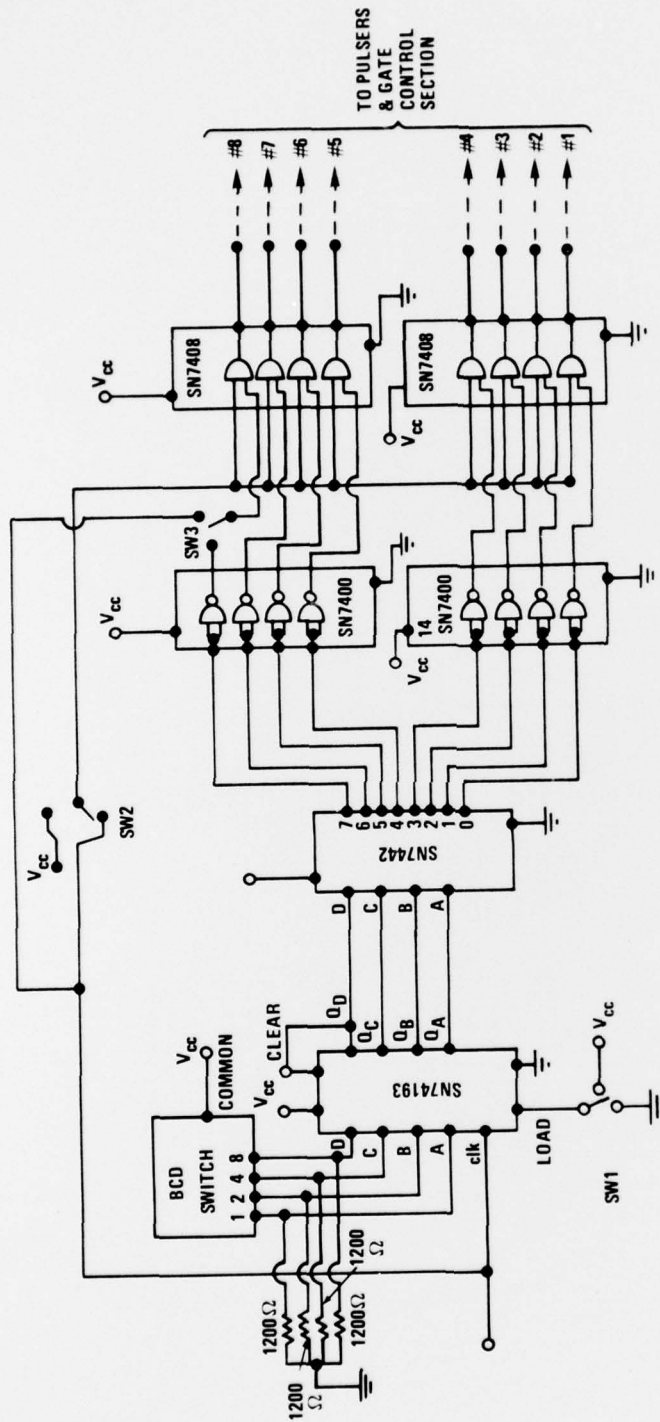

Fig. 6—Pulser control section, which allows for the selection of a transducer to be pulsed and for the sequencing of transducers

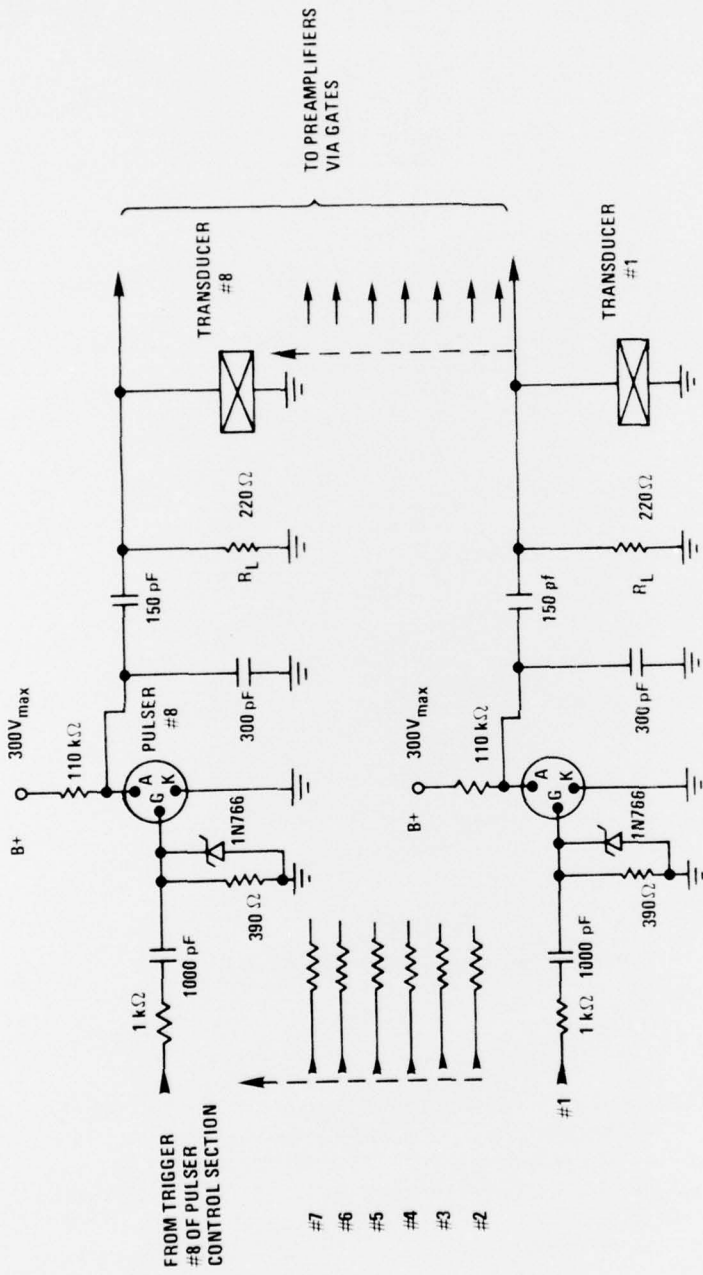

Fig. 7—Pulser section, which provides a sharp excitation pulse for the transducers

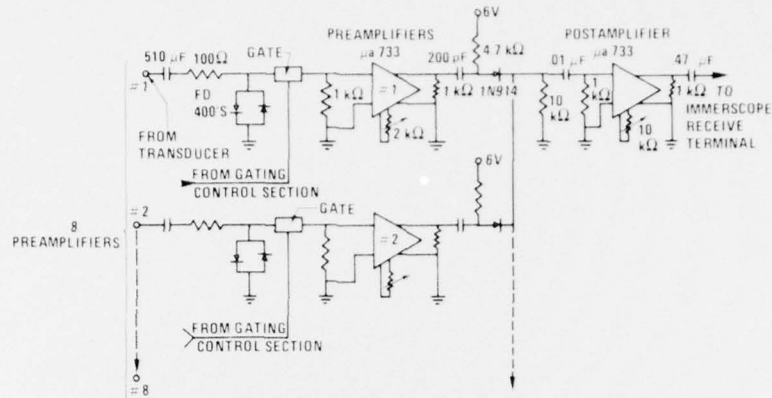

Fig. 8—Preamplifiers and postamplifier. The gains of the preamplifiers are adjusted to equalize transducer responses of all transducers with respect to a standard target. The postamplifier collects and amplifies all signals from the preamplifiers and sends them to the ultrasonic test instrument.

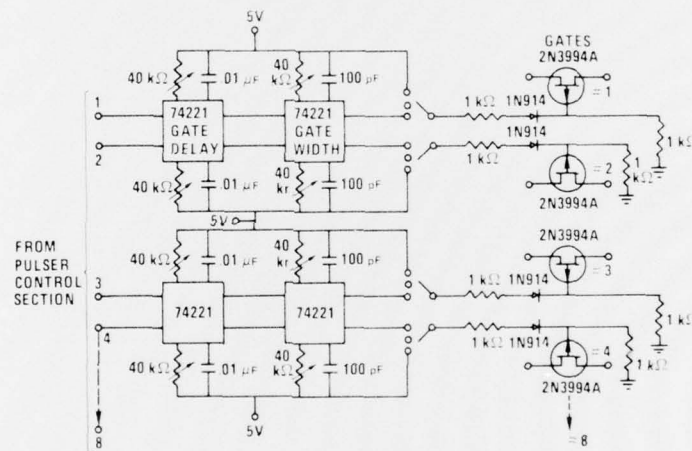

Fig. 9—Analog gates used for gating signals from the preamplifiers

ARRAY PERFORMANCE

Optimally, beams from all the transducers should converge at a point on the axis of the array. The actual degree of convergence was checked by mounting the array on the scanning head of an ultrasonic test tank and placing a 1-inch (2.5-cm) ball below it as a target. The array was scanned back and forth at different heights above the ball. At each height, the recorder plotted the position of the center of the array as the target was detected by each transducer. In other words the recording shows the point at which the ball intercepts each transducer beam. When the ball was close to the array, each transducer appeared to indicate the position of the ball differently, as shown at top of Fig. 10. As the height above the ball was increased, the indicated position moved toward the center of the array until a height was reached at which all transducers indicated the position to be at the same point (Fig. 10, bottom). This

was the point at which the center lines of the beams from all transducers appear to converge. However, when these indications are all projected onto the scan plane using a linear least-squares fit, some errors in the convergence are indicated (Fig. 11). A similar projection on a vertical plane (Fig. 12) also shows this. However, since there is beamwidth, the offsets shown in Figs. 11 and 12 are not evident in Fig. 10, because the zone of convergence is broader than the positioning error. Hence the directional imperfections are not significant.

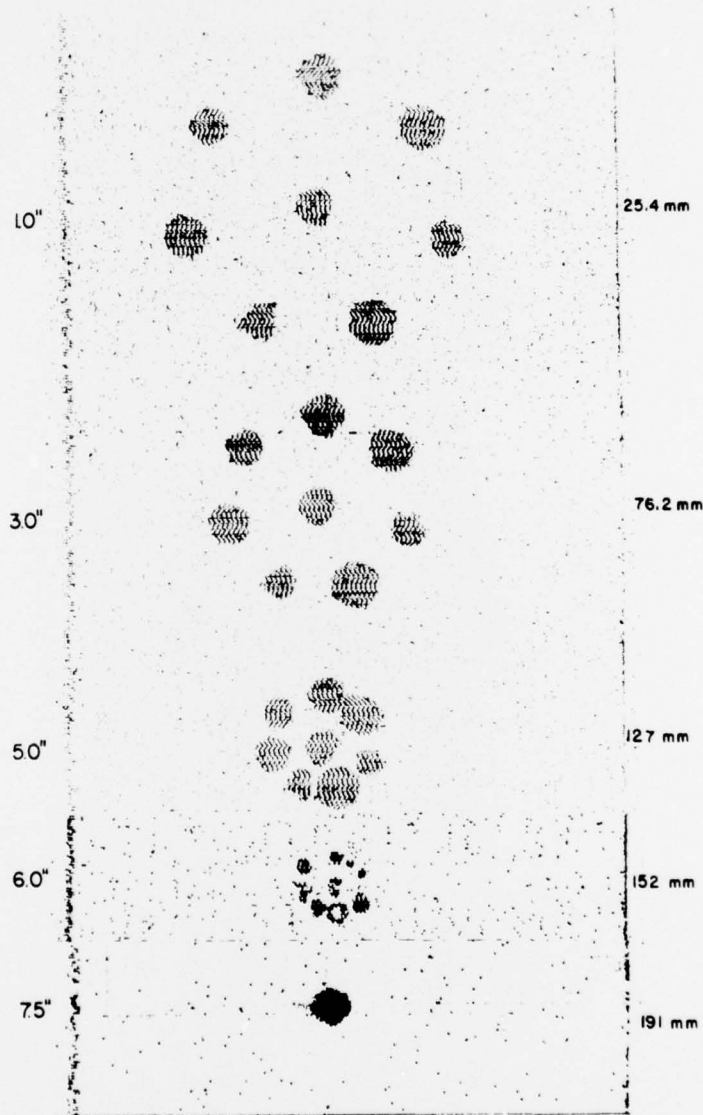

Fig. 10—A series of mappings from the array at various heights above a steel ball

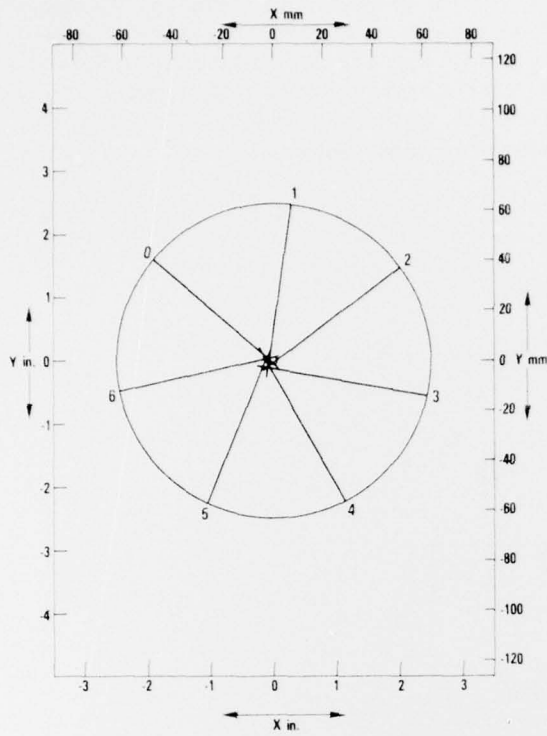

Fig. 11—Ultrasound rays as projected in the horizontal plane, showing the degree of alignment of the transducer beams

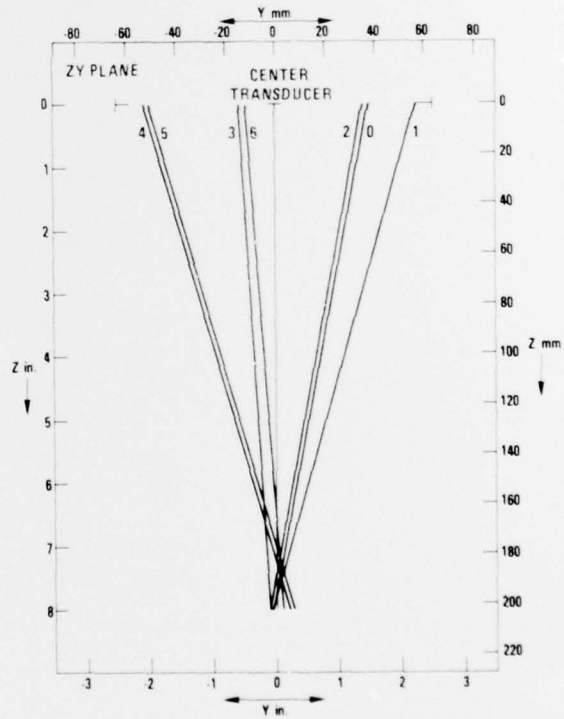

Fig. 12—Ultrasound rays as projected in the vertical plane, showing the degree of alignment of the transducer beams

The offsets may become significant when a different type of target is encountered. A slot 0.5 inch long by 0.1 inch deep (1.3 cm long by 0.3 cm deep) was milled in a steel plate to simulate a crack. The plate was mounted on a turntable and scanned with the array several times, with the plate being rotated several degrees between scans. Figure 13 shows set of scans at different angles. The multiple indications in three of the scans result because the transducer-beam centerlines are not all aimed at the same point. For flaw detection this multiplicity is not serious, but if the array is to be used in flaw evaluation, it becomes important. In retrospect it would have been desirable to provide means for adjusting the beam directions to insure focus of the device.

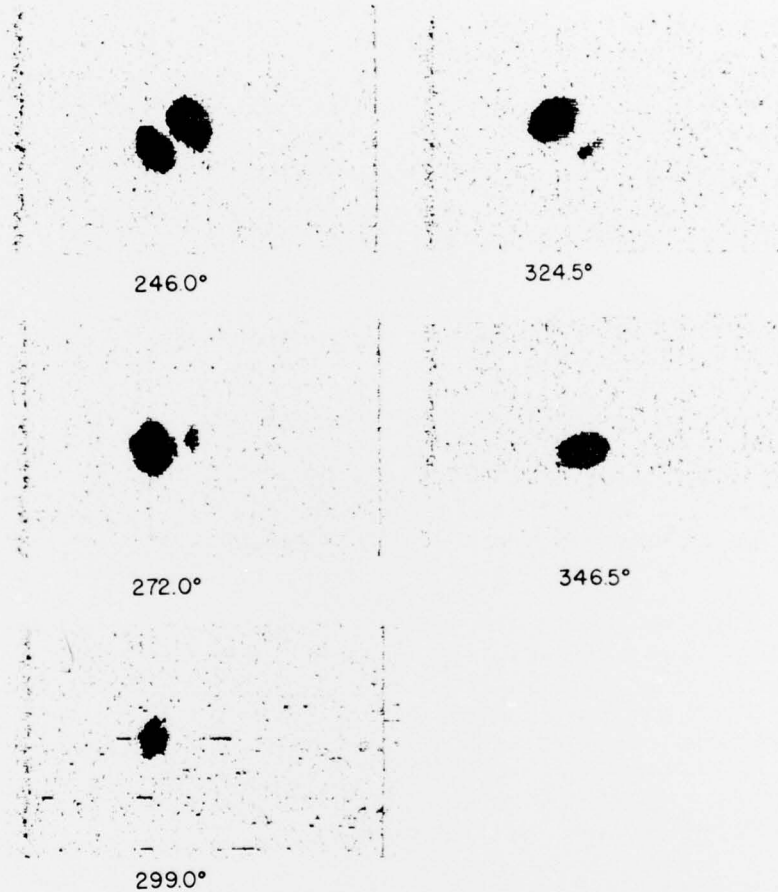

Fig. 13—Recordings of a vertical slot in a 3/4-inch-thick (1.9-cm-thick) plate oriented at various angles. The angular reference is arbitrary. The multiple images are due to the inexact alignment of the transducers.

In the experimental model, coverage for all possible angles of a flat flaw is not complete. This is illustrated in Fig. 14, which shows the echo strength observed as the flaw is rotated about an axis through the center of the array. Even when one considers the possibility that echoes of pulses sent out from one transducer may be received by another, there are gaps in detection, because the beam spread is narrow. Widening the beam would improve matters, but this must be done carefully to avoid direct transmission from one transducer to one approximately opposite.

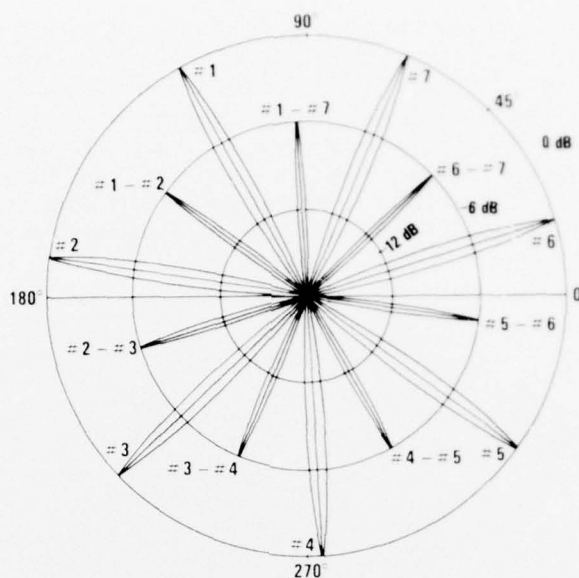

Fig. 14—Detection sensitivity of the array when a flat reflector target is rotated relative to the axis of the array

DISCUSSION OF ANGULAR DISTRIBUTION OF SENSITIVITY

The gaps in response (shown in Fig. 14) are due to the high directivities of the target and of the transducers used. Figure 15 illustrates the rapid decrease in sensitivity as the target is moved away from the transducer axis for the transducers actually used ($D/\lambda = 60$) and for a transducer with 1/3 the diameter ($D/\lambda = 20$).^{*} Both are normalized to the response from a target directly on the axis of the transducer. The plots indicate that the smaller transducer could detect the same target over a wider angular range than the larger one. However, targets also have directivity, and the same rules apply. Thus we have the interesting result that a small target (less than 4 wavelengths), although reflecting lower amplitude signals than would a large target (greater than 4 wavelengths), reflects the signals over a wider angle and hence may be more reliably detected than a large target. Thus the result is that the amplitude of the signal from a small target will vary less rapidly with angle than will that from the large target, so that if the signal is strong enough to be detected at all, it may remain strong enough over a wider angle. This result could be used to aid in flaw evaluation.

Two factors then are involved for the gaps in response shown in Fig. 14. The gaps in sensitivity could be closed by using transducers with wider beam spread, by using more transducers, or by using both. In ship construction relatively large flaws are sometimes permissible (NAVSHIPS 0900-006-3010 allows up to 1.5 inches (3.8 cm) in length in one class). Such flaws would be highly directional in comparison with a small flaw. A widely diverging beam could be used in order that portions of the beam might return to the sending transducer. This is illustrated schematically in Fig. 16 for a simple case. The actual ray diagram for the array and

^{*}H.H. Chaskelis and S.D. Hart, "The Significance of Target Geometry on Far-Field Beam Patterns," Proceedings of 10th Symposium on NDE, Apr. 1975.

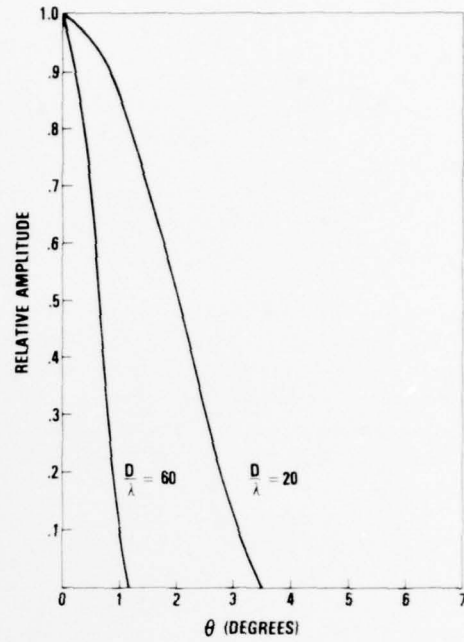

Fig. 15—Sensitivity vs angle from the axis of the transducer for a flat circular reflector

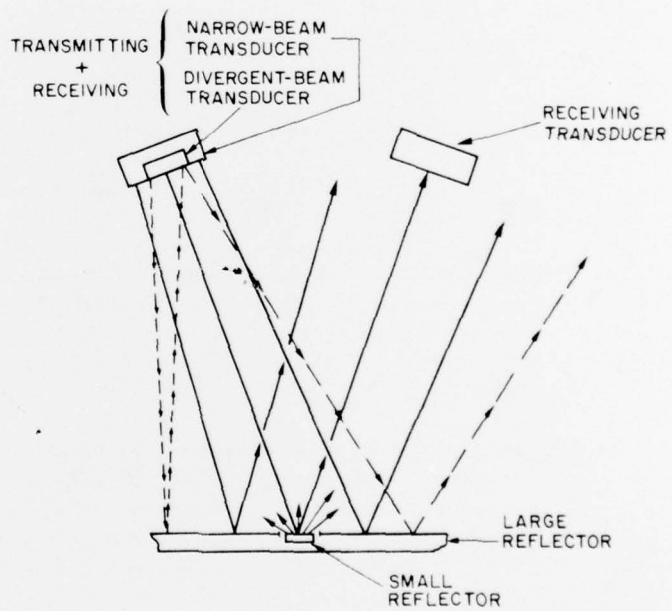

Fig. 16—Projection of ultrasound rays from large and small transducers being reflected from small and large flat reflectors. (Large reflectors are considered to be larger than 4 wavelengths, and small reflectors less than 4 wavelengths.) Solid lines correspond to the narrow-beam transducer, and the dotted lines correspond to the divergent-beam transducer, with the centerline being common to both.

a target in a plate is much more complex. The widely divergent beam would be weaker, because the radiated energy is distributed over a wider angle. Practical transducers are not likely to have angles of divergence, at 6 dB down, of more than 5°. Thus the term *widely divergent* is relative. If truly wide divergence could be accomplished in a practical transducer, there would also be a penalty in that the beam would be refracted over a wider angle in the plate in the conversion to shear mode. This could cause uncertainty in flaw location as well as result in direct transmission to opposite transducers on the ring. Figure 16 also shows a second transducer in place to receive the echo from the large flaw. Any two transducers in the array could operate in this way (not just adjacent pairs).

In conclusion, the distinction between detection and evaluation should be emphasized. The preceding discussion has been in terms of detection. Once a flaw has been detected, its significance to the life and strength of the structure has to be evaluated. This involves having information as to shape and orientation as well as size. An array of the sort described here may be connected to more sophisticated circuitry for the analysis of signals received by the various transducers, from which size, shape, and orientation can be deduced, and an evaluation can be made.

COMPUTER-AIDED FLAW EVALUATION

With the assistance of a computer the circular transducer array could become a powerful tool for characterization and evaluation of flaws. With appropriate computer software, the scanning and sequencing modes of the array could be controlled, and information as to size, shape, orientation, and position of a flaw obtained and stored in memory as flaw characterization. A next step in the computer-assisted operation would be the evaluation or comparison of the flaw characterization data with flaw data parameters which are known to be detrimental to the strength and life of the structure being inspected. Finally, using computer graphics, a visual characterization of the flaw could be projected, rotated, and viewed at all possible aspect angles, for human interaction.

CONCLUSIONS AND RECOMMENDATIONS

The use of a circular array of sequentially operated transducers for detection of randomly oriented flaws appears a viable concept, which could result in improved reliability and reduce the cost of nondestructive evaluation of weldments. Observed variations in detection sensitivity can be explained in terms of transducer and target beam-pattern characteristics, which could be easily corrected in production units.

To obtain the full benefits of a device of this sort, it should be mounted on a mechanical scanner with automatic control. A further step in sophistication would be the incorporation of overall computer control of both the mechanical and electronic functions. The device would be used for both search and evaluation. Detection of a defect would initiate an interrogation action in which the scanner would be stopped and automatically positioned over the defect; the transducers would be actuated in turn, and echoes from the flaw would be compared in the computer for information as to its nature and size. By use of computer graphics, it would be possible to project a visual characterization of the flaw which could be rotated and viewed from several angles to aid computer-human interaction.

ACKNOWLEDGMENTS

This work was performed in the Structural Reliability Section of the Ocean Technology Division. The transducer array is an extension of a previous *omnidirectional* search unit designed by L. C. Cardinal, now retired. The authors are grateful to H. H. Chaskelis and R. J. Sanford for their advice and consultation.

DAT
FILM