

AD-A041 525

GORWARA ASSOCIATES SAN MATEO CALIF  
STUDY ON MILLIMETER WAVE MIXERS. (U)  
APR 77 A K GORWARA

F/G 9/5

N00173-76-C-0195  
NL

UNCLASSIFIED

4 OF 12  
AD  
A041525



END

DATE  
FILMED  
7-77

2 P.S.

GORWARA ASSOCIATES, San Mateo, Calif

630 SOUTH EL CAMINO  
SAN MATEO, CALIF. 94402

ADA 041525

11 APR 1977

9 FINAL REPORT,

12 26p.

6 STUDY ON MILLIMETER WAVE MIXERS,

10 BY ASHOK K. GORWARA

PREPARED FOR:

NAVAL RESEARCH LABORATORY  
WASHINGTON, D.C. 20375

AD NO. DDC FILE COPY

CONTRACT

15 NO0173-76-C-0195

DDC  
RECEIVED  
JUL 12 1977  
A

UNANNOUNCED	Justification
Justification	letter on file
BY	
DISTRIBUTION, AVAILABILITY CODES	
Dist.	AVAIL. REG. W. SPECIAL
A	

New 410269

DISTRIBUTION STATEMENT A  
Approved for public release;  
Distribution Unlimited

## STUDY ON MILLIMETER-WAVE MIXERS AND APPLICATIONS

### A. Mixer Types

For years waveguide-type mixers were the only ones available at frequencies above 18 GHz. However, more recently design techniques that were previously considered only suitable at microwave frequencies have been extended to millimeter-wave frequencies. These developments can be separated into two groups. True balanced mixers in waveguide have been built using packaged diodes combined with coaxial IF circuits (Spacekom).<sup>1</sup> These mixers differ from conventional balanced mixers in that they do not employ a separate hybrid such as a short-slot hybrid or a magic tee. Rather the diodes are arranged in a bridge circuit thus leading to a compact mixer with excellent LO-RF isolation. This type of mixer is capable of covering entire waveguide bands and high IF frequencies. The second development of importance is the emergence of mixers using integrated circuit techniques at millimeter-wave frequencies. Logical extensions of lower-frequency designs in microstrip were pursued by Oxley in England and researchers at SRI<sup>2</sup> and at NELC. These developments have shown that balanced and image reject mixers are feasible using microstrip on sapphire, quartz and Duroid up to and beyond 60 GHz. A printed circuit version of the true balanced mixer mentioned above was developed at SRI<sup>2</sup> for full waveguide bands from 18 to 66 GHz.

The mixers to be considered can be divided into three different groups, namely narrow-band mixers, wideband mixers with low IF for swept receivers, and wideband mixers for channelizer applications, which are characterized by the need for a high IF. The narrowband mixers are usually sufficient for communications applications. Conventional waveguide mixers can satisfy most of the related requirements. For surveillance purposes wide-band mixers are required and the following discussions

will concentrate on those. Six different mixer types that fall into the latter two categories are listed in Table 1 together with some of their pertinent characteristics. The following description deals in more detail with each of those mixers and identifies areas that require additional work.

1. Single balanced mixers using  $90^\circ$  - hybrids

Single balanced mixers with quadrature hybrids (FIGURE 1) are very popular at microwave frequencies. These mixers have good RF and LO VSWRs but usually poor LO-RF isolation. Their conversion loss is moderate because of the losses of the hybrid. The widest bandwidth is obtained with backward-wave couplers. These are difficult to build above 26GHz. A coupler was developed by Messers Gorwara and Chambers using microstrip on 10-mil sapphire for K-band.<sup>2</sup> This coupler consists of two cascaded 8.3-dB sections and represents the limit of that particular design (coupler length=3x strip-width). Above 26 GHz a quadrature hybrid based on the hybrid slotline coupler promises to be feasible to at least 40 GHz. NELC and other researchers have developed three-section branchline couplers for entire waveguide bands up to 60 GHz. These couplers have inherently only 13 dB directivity and large coupling imbalances. However, Oxley in England has used successfully branchline and rat-race hybrids for mixers up to 75 GHz covering more than 15% bandwidth. The substrate material for these mixers was sapphire or quartz. All of these MIC mixers employed beam-lead diodes. Matching of the diodes is in general not too difficult. In our opinion this type of mixer is well developed and the achievable performance characteristics are known. Most fabrication problems are also solved. Practical circuits are limited to microstrip on low or high-dielectric materials. This in turn requires transitions from waveguide, the common transmission-line medium at millimeter-wave frequencies, which adds significantly to the mixer conversion loss. Unless these mixers are integrated on the same substrate with other components, other designs such as those discussed in the next section, offer better performance,

BEST AVAILABLE COPY

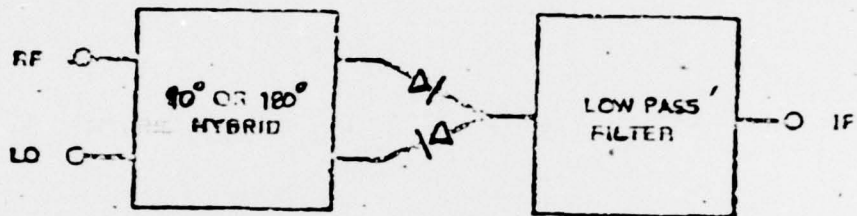

FIGURE 1: SINGLE BALANCED MIXER USING HYBRIDS

TABLE 1  
COMPARISON OF VARIOUS MM W MIXERS

MIXER TYPE	CONVERSION LOSS	SPURIOUS & RESP. LEVEL	LO-RF ISOL	RF	VSWR	INTERCEPT POINT	FABRICATION PROBLEMS
1) SINGLE BALANCED 90° HYBRID	MODERATE	GOOD	POOR	GOOD	GOOD	MODERATE	SEVERE ABOVE 26GHZ
2) SINGLE BALANCED 180° HYBRID	GOOD	GOOD	VERY GOOD	GOOD	POOR	MODERATE	MOSTLY SOLVED
3) DOUBLE BALANCED	GOOD	EXCELLENT	VERY GOOD	GOOD	GOOD	GOOD	HAVE TO BE SOLVED
4) QUADRATURE FED MIXER	HIGH	EXCELLENT	GOOD	GOOD	GOOD	GOOD	SEVERE ABOVE 26 GHZ
5) IMAGE REJECT MIXER (IRM)	MODERATE	GOOD*	GOOD*	GOOD	MODER.*	GOOD	DIFFICULT ABOVE 26 GHZ
6) IMAGE REJECT + ENHANCED MIXER (IREM)	MODERATE	GOOD*	GOOD*	GOOD	MODER.*	GOOD	DIFFICULT ABOVE 26 GHZ

\* depends on type of mixer employed

\*\* The intercept point is directly proportional to the LO power level

+ Single balanced mixers suppress all even

because they circumvent the relatively lossy transitions from waveguide to microstrip.

## 2. Single balanced mixers using $180^\circ$ - hybrid

True balanced mixers using some form of integrated circuit techniques have been developed at NELC and SRI. The NELC-design by Kihm and Hislop<sup>3</sup> uses chip diodes and a printed circuit for the LO input and IF output. The SRI<sup>1</sup> design, however, is completely printed on quartz or sapphire substrates and utilizes beam-lead diodes (FIGURE 2&3). The high symmetry achievable in these mixers is evidenced by the excellent LO-to-RF isolation and the high degree of LO-AM noise suppression. The latter is important in applications where a noisy LO has to be used (e.g. IMPATT oscillators). Matching of the diodes at one port (usually the LO port) is difficult, because two diodes appear in parallel resulting in a low impedance level. Beam-lead diodes with a lower junction capacitance would greatly ease the matching difficulties. The only suitable diodes available presently are manufactured by AEI in England. These diodes have  $C_j < .08$  pf. Desirable would be a diode with less than 0.04 pF. Also, the AEI diodes are not mechanically strong. Development of an improved GaAs beam-lead diode suitable for millimeter-wave applications should be pursued. The conversion loss of these balanced mixers with  $180^\circ$ -hybrids is low partially due to the low losses of the short transformer section between the input waveguide and the diodes. In addition, the true balanced construction separates the even and odd idler signals. Odd idlers appear at the RF port, whereas even idlers emerge from the LO port. This allows better control over the idler impedances and generally gives better conversion loss compared with single ended mixers.\* Most fabrication problems of this type of mixer have been solved and fabrication in larger quantities could start after a short advanced development.

---

\*In a single-balanced mixer using a  $90^\circ$ -hybrid each diode is completely separated from the other. Therefore, this type of mixer consists of two single-ended mixers as far as idler signals are concerned.

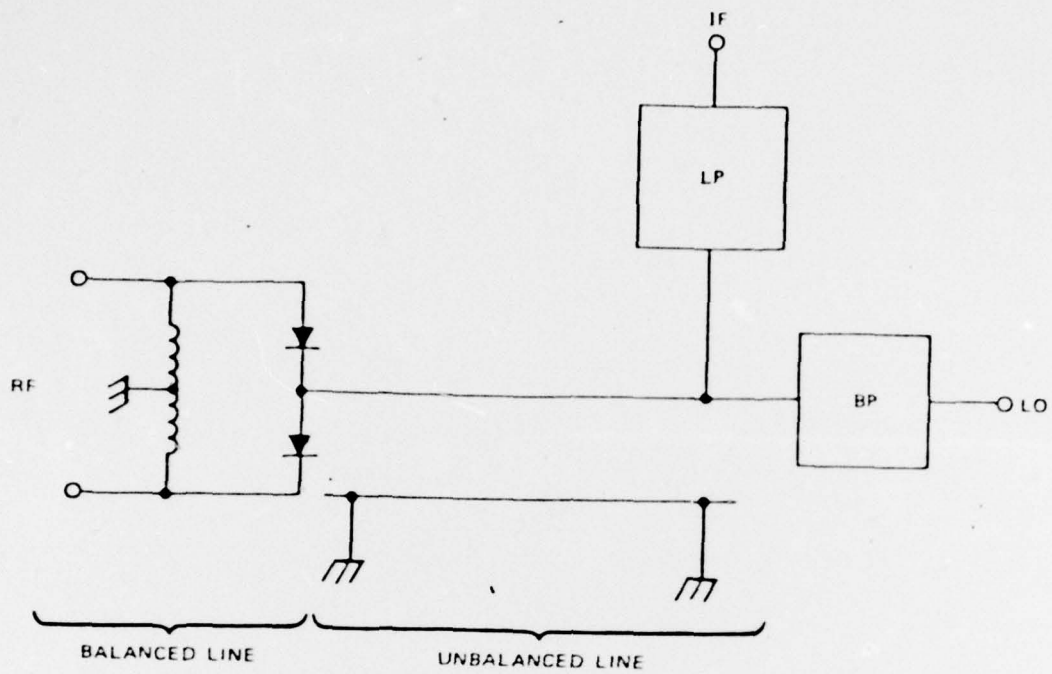

TA-652583-76

FIGURE 2. SCHEMATIC OF Ka-BAND MIXER USING BALANCED AND UNBALANCED LINES

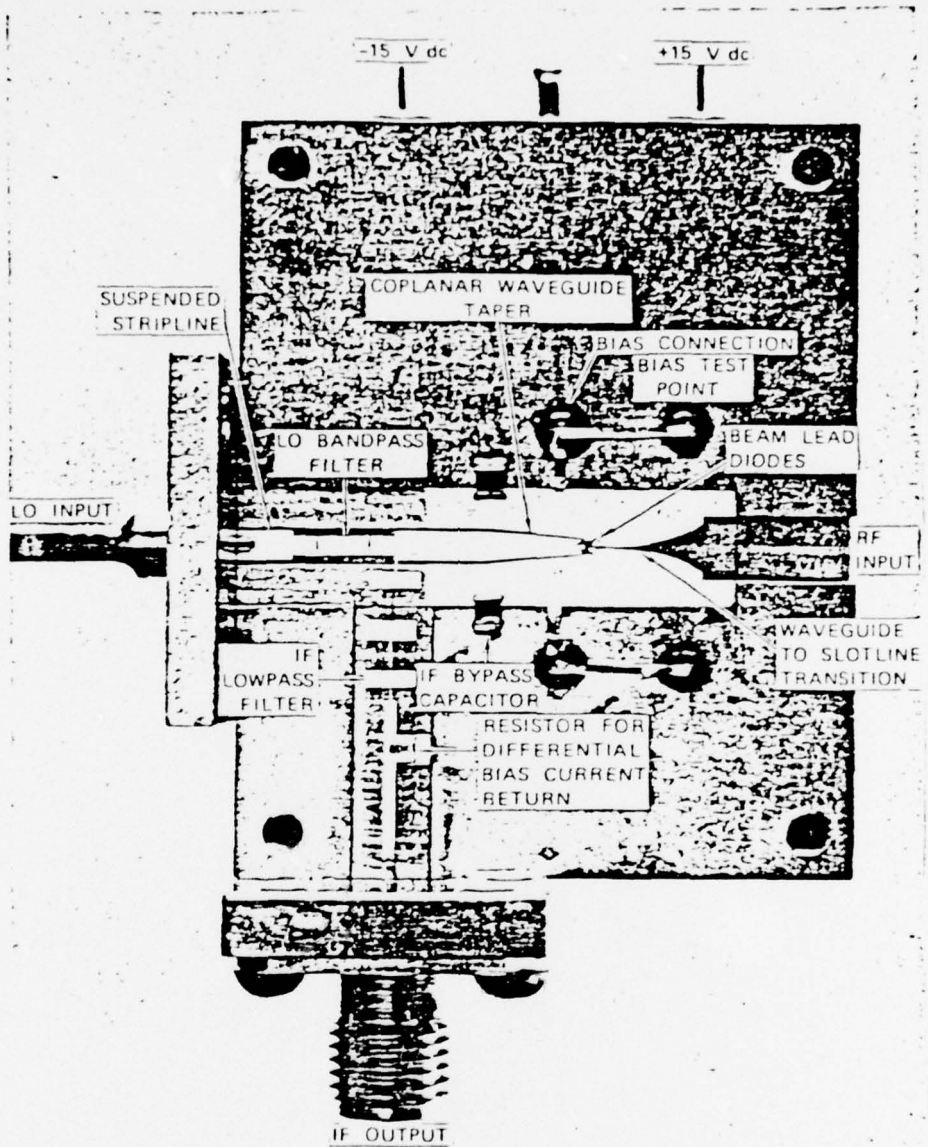

TA-652583-233

FIGURE 3 DETAILED VIEW OF THE BALANCED MIXER CIRCUIT FOR 26.5 to 40 GHz

### 3. Double-balanced mixer

To our knowledge no double-balanced mixers (using a diode ring or a diode star) have been developed above 18 GHz. Double-balanced mixers would be highly desirable for the following reasons: Double-balanced mixers have the best spurious response characteristics of any mixer. The bandwidth of double-balanced mixers is only limited by the bandwidth of the baluns (or transformers) employed. In contrast most single-balanced mixers are limited to about an octave because of the bandwidth limitation of the quadrature coupler in mixers with  $90^\circ$  hybrids, or of a quarter-wave stub that is an integral part of all microwave  $180^\circ$ -balanced mixers. Double-balanced mixers have equal impedance levels on both the RF- and LO-side making them more easily matched at both those ports. Double-balanced mixers have not yet been developed because of the great difficulty in forming a symmetrical diode junction that can accommodate four diodes.\* Absolute symmetry is paramount if a high degree of LO-RF isolation shall be achieved. The problem of designing broadband baluns which are required for double-balanced mixers with unbalanced input lines (e.g. coaxial) does not exist at millimeter wave frequencies, if the inputs to the mixer are in waveguide (a transmission line which is already symmetrical). A possible geometry for a double-balanced mixer is shown in Figure 4. A major unsolved problem of that design is the practical realization of the multi-mesa diode junction. However, a solution seems to be possible. The IF bandwidth of the proposed double-balanced mixers appears to be limited to a few GHz due to the large bypass capacitors needed for the RF or LO signal.

---

\*Double-balanced mixers lead always to non-planar geometries.

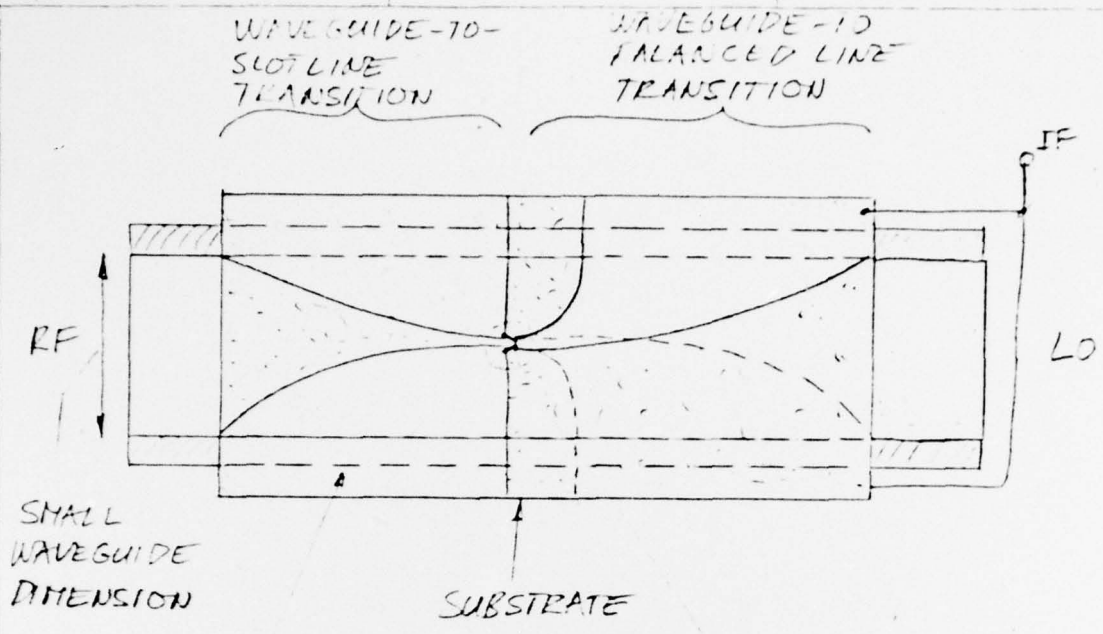

METALIZED ON BOTH SIDES, DC CONNECTED TO ENCLOSURE

BEST AVAILABLE COPY

BOTH SIDES OF SUBSTRATE IDENTICAL

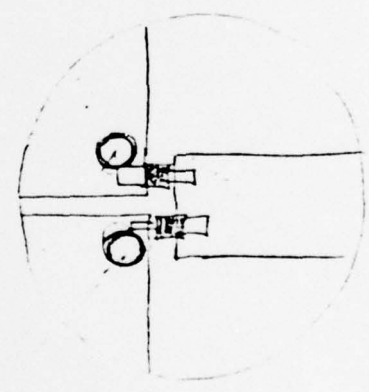

PLATED THRU-HOLES

FIGURE 4 DOUBLE BALANCED MILLIMETER-WAVE MIXER

#### 4. Quadrature-fed Mixers

Quadrature fed mixers (FIGURE 5) are a form of a double balanced mixer that was developed for frequencies below 18 GHz and which can be built in a quasi-planar construction. These mixers require four quadrature hybrids and are therefore, restricted in the same way single balanced mixers are using quadrature hybrids in a quadrature fed mixer, its losses are relatively high. This type of mixer does not offer any advantages over a double-balanced mixer and therefore is not recommended for development above 18 GHz.

#### 5. Image-reject mixer (IRM)

Conventional image-reject mixers (FIGURE 6) require at least one quadrature hybrid. Therefore, they are subject to the same limitations as single-balanced mixers using  $90^\circ$ -hybrids. However, by placing the quadrature hybrid in the LO path, less stringent specifications as far as coupling imbalance is concerned, can be accepted. This makes branchline couplers amenable for IRM. The two single-or double-balanced mixers of an IRM, however, could be built using  $180^\circ$ -hybrids to circumvent the use of additional quadrature hybrids. Conceivable is a design employing the type of mixer covered in Section 2.

#### 6. Image-reject and image-enhanced mixer

By replacing the inphase hybrid at the RF input of a conventional image-reject mixer by a direct parallel or series connection, image rejection as well as image enhancement can be obtained (FIGURE 7). It would be relatively easy to connect two  $180^\circ$ -hybrid balanced mixers of the kind developed by SRI in series by feeding them from a slotline T-junction (FIGURE 8). This design would be no more difficult to realize than a conventional image-reject mixer, but would offer improved conversion loss due to the image enhancement, which in this case is obtained through phasing techniques. The upper frequency limit of such a

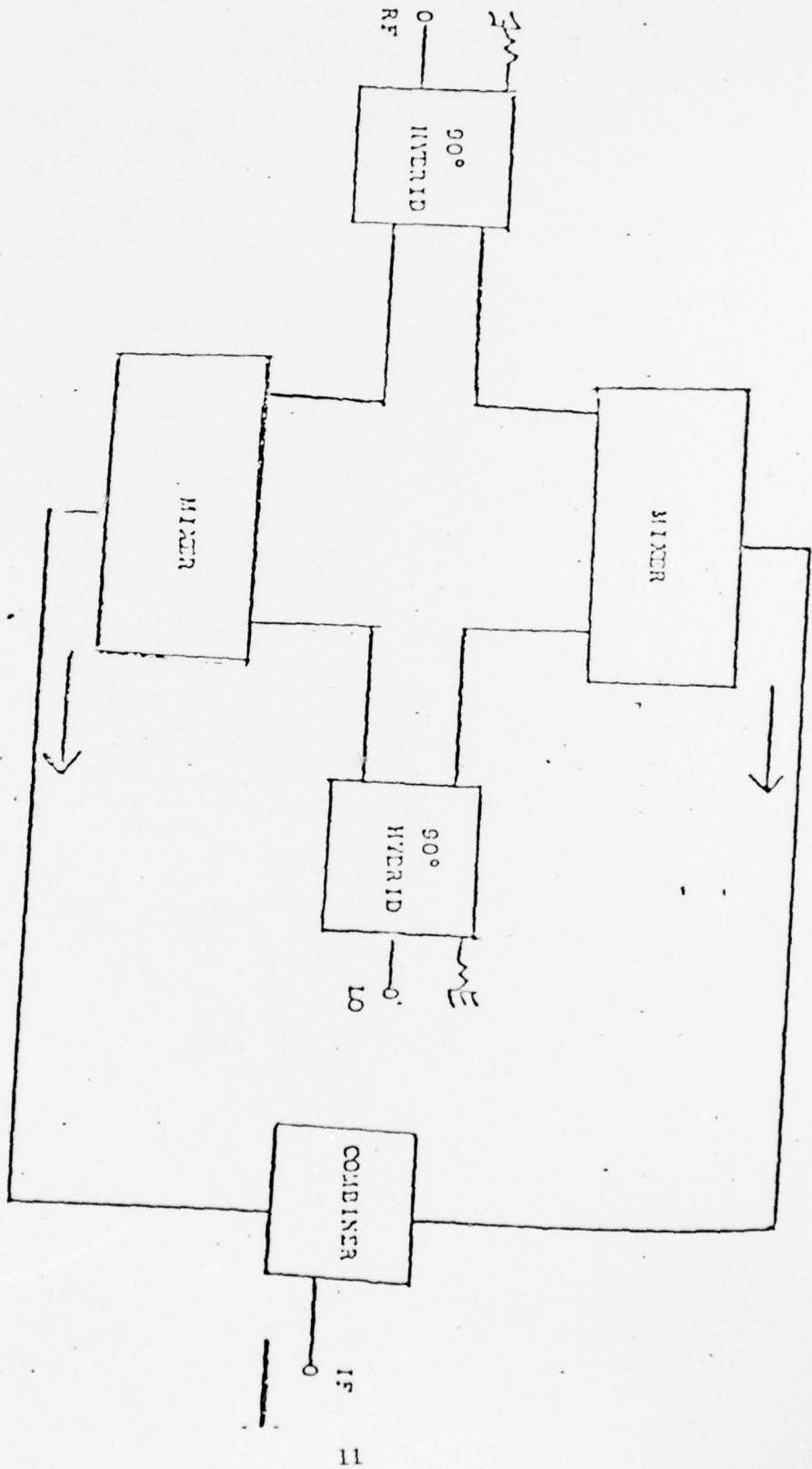
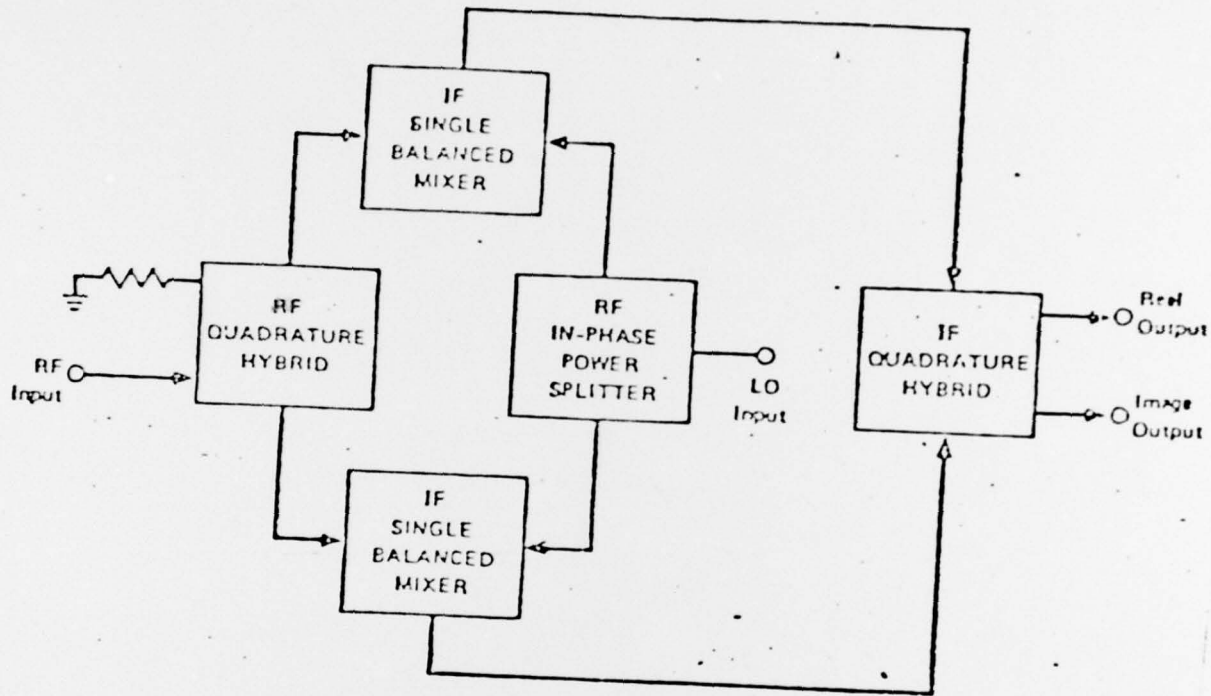

Figure 5. QUADRATURE FED MIXER



UNCLASSIFIED

TAG52563-04

FIGURE 6 IMAGE REJECT MIXER

BEST AVAILABLE COPY

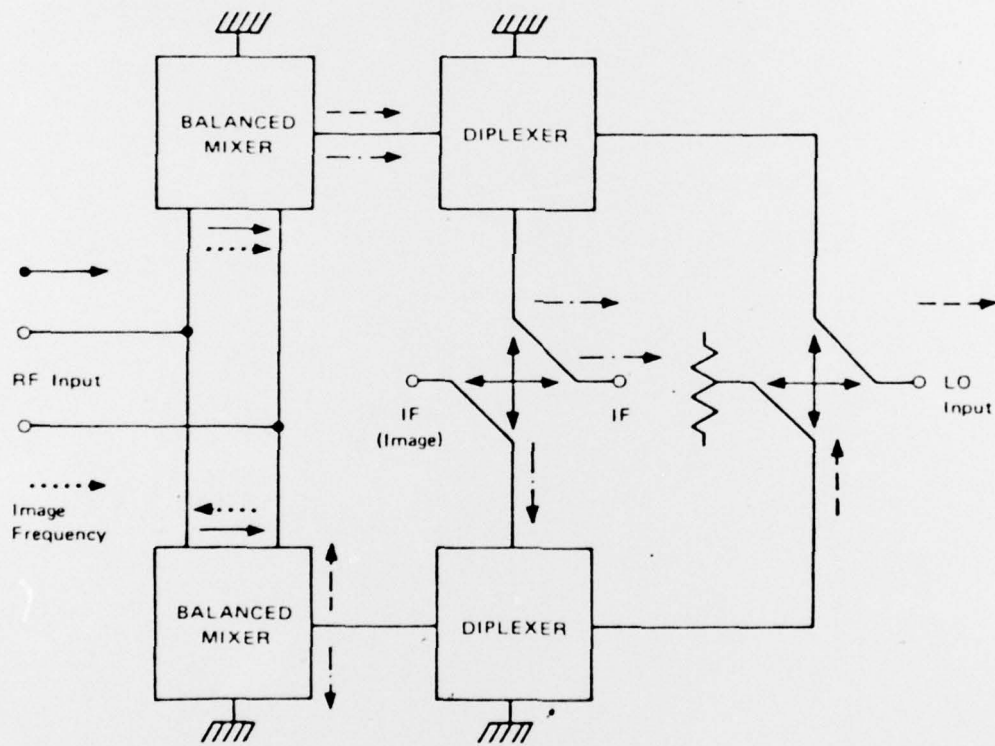

TA-652583-188

FIGURE 7 PRINCIPLE OF OPERATION OF WIDE-BAND, IMAGE-ENHANCED MIXER

BEST AVAILABLE COPY

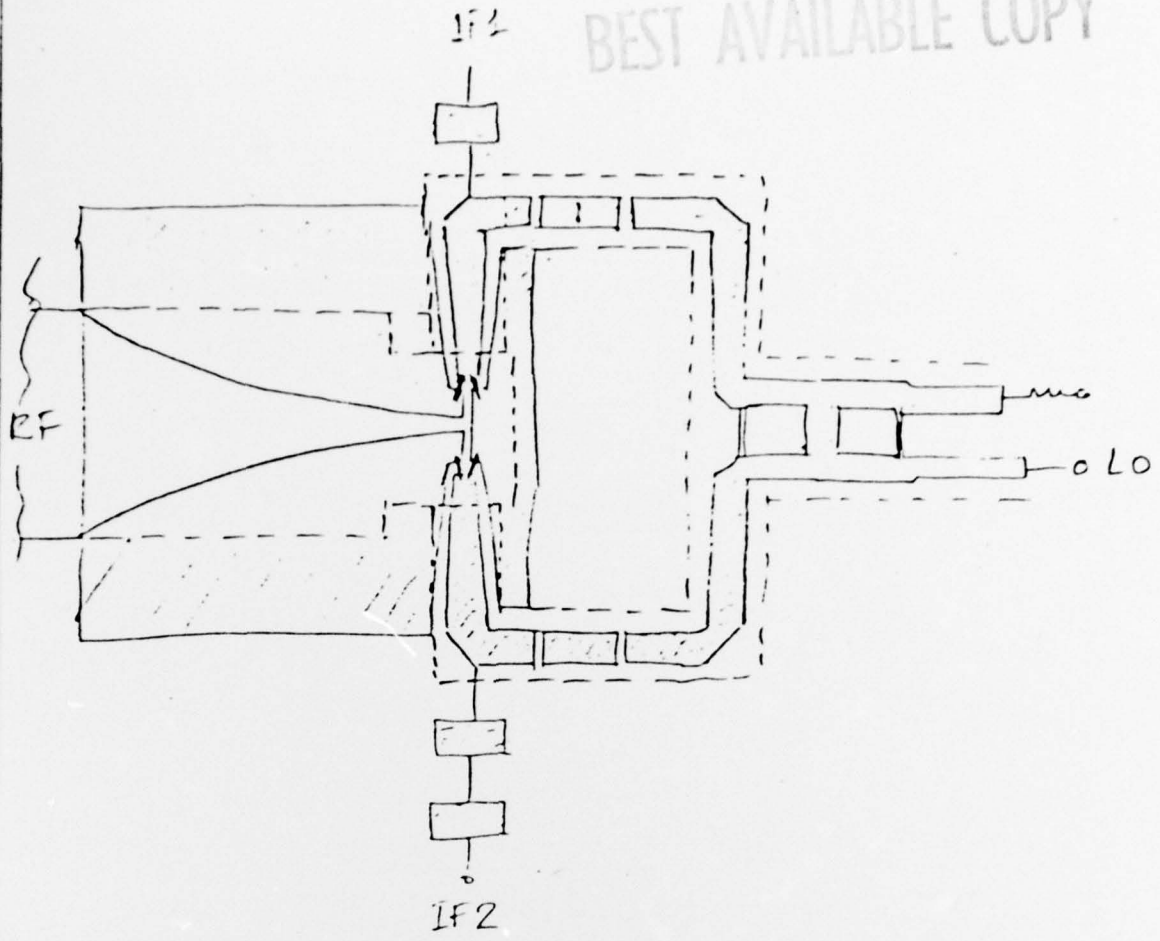

FIGURE 8 IMAGE REJECT AND ENHANCED MIXER  
EMPLOYING TWO BALANCED MIXERS

design may be limited to 40 GHz due to constraints set by the size of the beamlead diodes.

#### B. Comparative Systems Study

The selection of a particular mixer is strongly influenced by the type of receiver, for which the mixer is intended. In this study four different types of receivers are distinguished: Channelized, IFM, Superhet, and Microscan.

As far as the millimeter wave downconverter is concerned its characteristics are essentially the same for a channelized receiver or a IFM (assumes an IFM at the IF). In both cases a relatively large RF band (typically 4 GHz) is downconverted to a high IF (typically 4-8 GHz). The LO frequency is fixed. The high IF results in a large separation between the real and image band and RF filters can eliminate the image response entirely. This means that image frequencies generated in the mixer are reactively terminated, and care has to be exercised in positioning the RF filter with respect to the mixer. Neglecting this point can lead to excessive conversion loss variations due to alternating image enhancement and deenhancement in the mixer. In practice this requires RF filters very close to the mixer diodes (the distance is a function of the fractional RF bandwidth). Single-balanced mixers with  $90^\circ$ -hybrid mixers and double-balanced mixers are well suited for channelizer and IFM applications. The image reject mixer (IRM) and image reject/image enhanced mixer (IREM) discussed above are not necessary in those cases, because image enhancement and rejection can be obtained with filter techniques.

Superhet and microscan receivers require mixers with wide RF and LO bandwidth. The IF frequency however is fixed and relatively low. Single balanced (both types) and double balanced mixers can be used for both applications. A selection should be made based on the mixer performance characteristic, the desired or required circuit technology, and frequency. Image-reject or image-reject and enhanced mixers are preferable for superhet receivers, because they permit the elimination of electronically tunable preselectors (typically a YIG filter),

which are costly and lossy. Microscan receivers on the other hand, automatically discriminate against image responses, and hence, require neither IRM nor IREM. Table 2 shows a summary of the various types of mixers that could be used for various systems.

### C. 40 to 60 GHz MIXER DESIGN APPROACH

#### 1. Principle of Operation

It is easiest to explain the basic features of a mixer design ideal for 40-to-60-GHz applications as shown in schematic diagram of Figure 9. A hybrid junction is formed by suitably connecting two transmission lines with orthogonal field distributions. The two transmission lines can also be distinguished as being balanced and unbalanced. In the particular design chosen, the RF signal is incident on a balanced line, with impedance  $Z_b$ , whereas the unbalanced line with impedance  $Z_u$  carries the LO power.

A mixer results when two diodes with equal polarities are added in series across the RF line as shown in Figure 9. In contrast, the LO sees an antiparallel diode pair. Analysis shows that the intermediate frequency (IF) signal emerges on the unbalanced side. Therefore a diplexer is required to separate the LO from the IF signal. The diagram shows a diplexer consisting of the series connection of a lowpass and a bandpass filter. Alternatively, a parallel connection of suitable filters may be used.

A three-wire transmission line, which extends to the right of the diodes in Figure 9, supports the balanced or even mode as well as the unbalanced or odd mode. The dual-mode transmission line section is characterized by the even- and odd-mode impedances,  $Z_e$  and  $Z_o$ . Its length in the even mode,  $l_e$ , is nominally a quarter wavelength at midband. This line provides a return path from the outer terminals of the diodes to a common

TABLE 2 COMPARATIVE SYSTEMS CHARACTERISTICS

MIXER TYPE	CHANNELIZED RECEIVER OR IFM	SUPERHET RECEIVER OR MICROSCAN RECEIVER
	18-40GHZ	18-40GHZ
	40-60 GHZ	40-60GHZ
1) SINGLE BALANCED 90° HYBRID	UNSUITABLE	SUITABLE, GENERALLY INFERIOR TO 2
	UNSUITABLE	THEORETICALLY SUITABLE IN PRACTICE INFERIOR TO 2
2) SINGLE BALANCED 180° HYBRID	SUITABLE	SUITABLE
	SUITABLE	SUITABLE
3) DOUBLE BALANCED	DESIRABLE, HIGH	SUITABLE
	IF QUESTIONABLE	
	4-8 GHZ APPEARS FEASIBLE	
4) IMAGE REJECT ) MIXER )	NOT NECESSARY	HIGHLY DESIRABLE FOR SUPERHET,
5) IMAGE REJECT ) AND ENHANCED ) MIXER )	NOT NECESSARY	NOT NECESSARY FOR MICROSCAN RECEIVER.

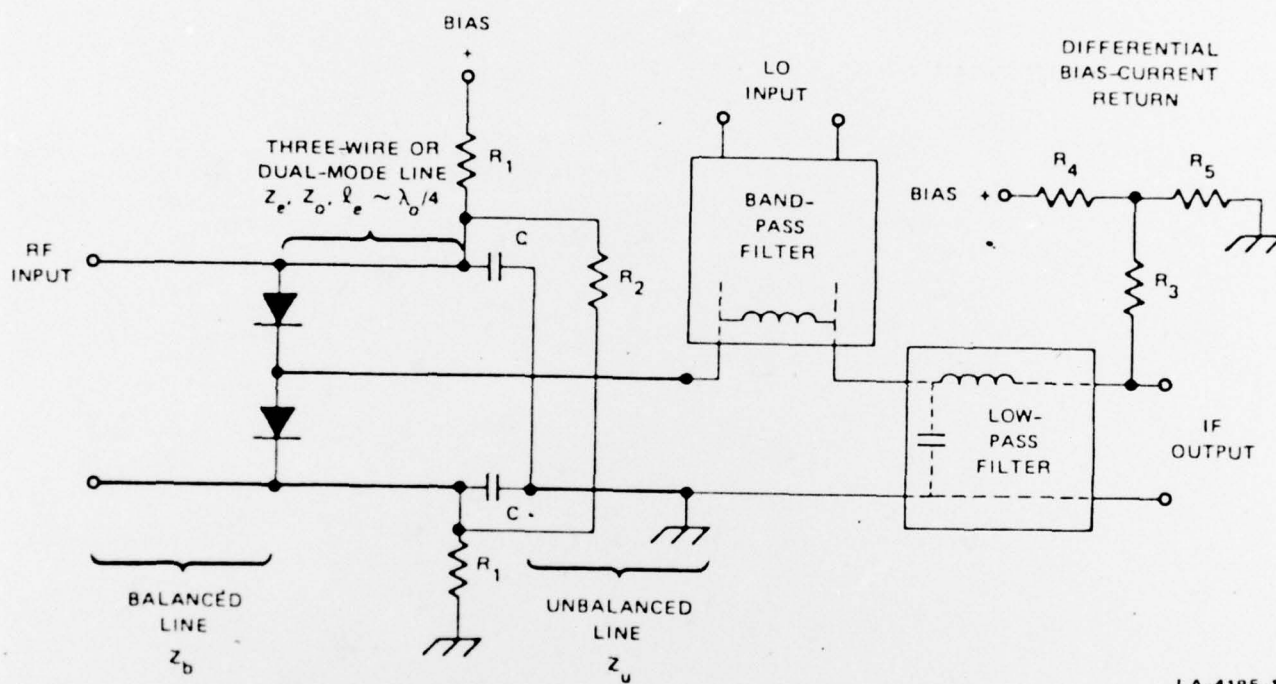

LA-4185-1

FIGURE 9 SCHEMATIC DIAGRAM OF SINGLE-BALANCED MIXER

ground for the LO and IF signal. In the unbalanced mode the two outer conductors have the same potential. If designed properly,  $Z_u$  equals  $Z_o/2$ , which allows impedance matching for the LO signal to the diode junction. In the balanced mode the center conductor of the three-wire line will not carry any current, and the line appears as a short-circuited stub of impedance  $Z_e$  and length  $l_e$ , that is connected in parallel with the diodes. A high characteristic impedance for this stub is desirable in order to reduce any deteriorating effect on the RF matching of the diodes. The capacitors C permit dc biasing of the diodes through the two resistors  $R_1$ . The resistor  $R_2$  is the principal dc load for the diodes. Its value is chosen to minimize noise-figure variations with changing LO power, as described by Gerst.<sup>7</sup> The difference in the bias current of the two diodes is returned through resistor  $R_3$  and the voltage divider consisting of  $R_4$  and  $R_5$ . Individual adjustment of the diode currents permits optimizing the LO-to-RF isolation. Usually the differential bias current is small, and a large resistor value for  $R_3$  can be used. Therefore a negligible amount of IF signal is lost in  $R_3$ .

So far, the physical properties of the balanced and unbalanced lines that can be used in the mixer have not been specified. Waveguide and two-wire line are obvious candidates for the balanced section, whereas a coaxial line or microstrip are appropriate for the unbalanced line section. For a completely planar circuit, slotline and coplanar stripline were found to be the most convenient choices for the balanced and unbalanced lines, respectively. The required transitions of the printed lines to the main waveguide inputs are explained in more detail in the next section. A desirable feature of the planar construction is that it allows the use of beam-lead Schottky-barrier diodes. Beam-lead diodes can be bonded in an operation that is much simpler than that required for the mounting and contacting of chip diodes. Furthermore, the beam-lead devices can be matched to the RF and LO ports over a wide bandwidth.

## 2.0 DIODE SELECTION AND MATCHING

The performance of any mixer, particularly of a broadband millimeter-wave mixer, is very much dependent on the availability of suitable diodes. Characteristics of modern Schottky-barrier diodes of Si and even more so of GaAs closely approach the theoretical characteristics of the ideal exponential diode. Recently GaAs diodes in beamlead form with a typical cutoff frequency of 750 GHz have become commercially available.\* Because their junction capacitance and series inductance are both low they can be matched over full waveguide bands at frequencies up to 60 GHz. Several topics affecting conversion loss and matching network design warrant a detailed discussion.

The conversion loss of a mixer can be partitioned into four major components: (1) the conversion loss of the nonlinear device itself, (2) losses in the series resistance  $R_s$  of the diode, (3) mismatch losses at the RF and IF port, and finally (4) circuit losses in the external matching networks. The extremely high frequency range and the wide bandwidth of the present mixer dictated design priorities that are quite different from those that govern a narrowband design. The need for a good match at the RF port is the dominant factor. Based on the known junction capacitance of the diode, an RF junction resistance was selected that appeared to guarantee the realizability of a wideband matching network. Figure 10 (a) shows an approximate equivalent circuit of the beam-lead diode together with the few elements of the RF matching network. The diode parameters indicated in Figure 10 were determined with the exception of  $R_s$ , from RF impedance measurements on a previous government contract under the direction of the author.

---

\*DC 1308, AEI Semiconductors, Lincoln, England.

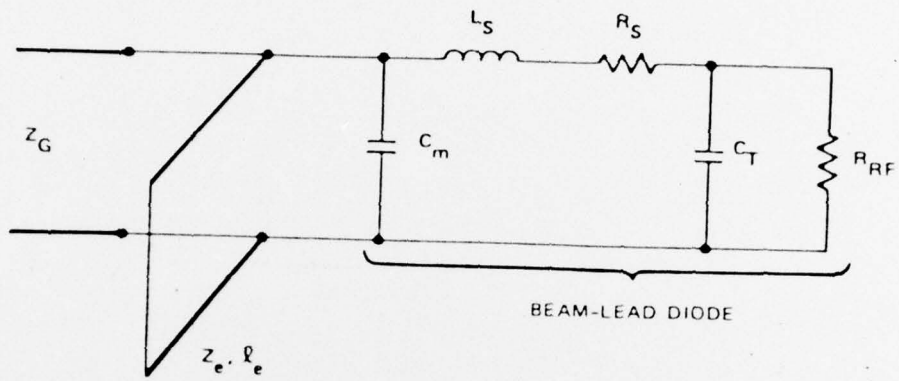

$Z_e \sim 100 \Omega$   
 $l_e = \lambda/4$  AT 50 GHz  
 $Z_G = 29 \Omega$   
 OPTIMIZED  
 FOR  $R_{RF} = 35 \Omega$

$C_T = 0.07 \text{ pF}$   
 $R_S = 4 \Omega$   
 $L_S = 0.08 \text{ nH}$   
 $C_m = 0.023 \text{ pF}$

(a) RF side.

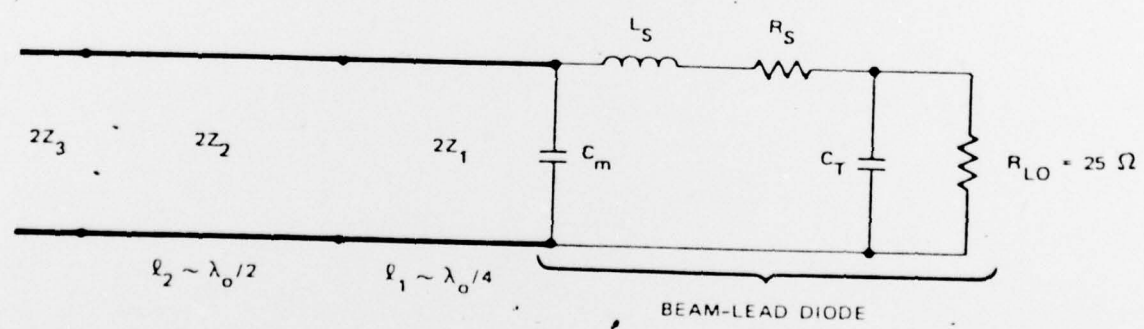

$Z_3 = 63 \Omega$      $Z_2 = 96 \Omega$      $Z_1 = 35 \Omega$

(b) LO side.

LA-4185-6

FIGURE 10 DIODE MATCHING NETWORKS

For that purpose two diodes were mounted in the first trial mixer circuit, and slotted-line measurements were made on the RF input port for different bias currents. This measurement technique yielded accurate diode data, because the diode embedding was essentially the same as that used later in the final mixer design. A separation of the true junction capacitance,  $C_j$ , from the package capacitance,  $C_p$ , was not possible. Therefore only the total diode capacitance,  $C_T$ , is shown. The capacitance  $C_m$  represents an additional lumped capacitance, contributed primarily by the gap across which the diode is mounted. The junction capacitance contribution,  $C_j$ , to  $C_T$ , is dependent on the bias voltage. Therefore the diodes were measured with a forward bias voltage of approximately 0.4 V, which corresponds to a typical operating bias point for the mixer.

The matching network consists essentially of  $C_m$ , which could be further increased over its measured value, a short-circuited stub of impedance  $Z_e$  and length  $l_e$  representing the contribution of the hybrid junction to the RF network, and the generator impedance  $Z_G$ , which is equal to half the slot-line impedance. Approximate values for  $Z_e$  were determined from measurements on scale models and on actual-size mixers. Depending on the dimensions of the coplanar stripline near the diode junction,  $Z_e$  varies from 100 ohms to 125 ohms. Hence its effect on the RF matching is small if  $l_e$  is chosen close to a quarter wavelength at midband. Computer optimization techniques were used to determine optimum values for  $l_e$ ,  $C_m$ , and  $Z_G$  as a function of the diode RF resistance,  $R_{RF}$ . Typically, a maximum VSWR of 1.1:1 over the full band was calculated for  $R_{RF} = 35$  ohms and  $Z_G = 29$  ohms, without augmenting  $C_m$  over its measured value. The impedance of the RF slotline is twice  $Z_G$ , or 56 ohms, which results in a gap width of less than 0.001 inch.<sup>4</sup> A further reduction in  $Z_G$  is not possible, because of an unrealistically small gap width.

Once  $R_{RF}$  has been determined, the LO as well as IF impedances and the various contributions to overall conversion loss can now be calculated. The following calculations are

based on Barber's paper,<sup>5</sup> in which he introduces the pulse duty ratio (PDR) as a more meaningful parameter to characterize mixer operation than peak local oscillator voltage. The pulse duty ratio was estimated to be 20% for the present mixer. The conversion loss of the lossless diode with all idler frequencies short-circuited, except for the image frequency, is then 3.9 dB. The series resistance of the diode causes losses on the RF and 0.20 dB for the IF side. They are estimated as 0.65 dB for the RF and 0.20 dB for the IF side. Mismatch losses on the RF side should theoretically be below 0.02 dB. Matching of the LO and IF side is more difficult. Here two diodes appear in parallel, which lowers the total IF impedance from about 50 ohms for one diode to 25 ohms for the two diodes in parallel. This low IF impedance adds another 0.5 dB in mismatch loss, if the mixer is connected to a 50-ohm IF load. Therefore total theoretical conversion loss of the mixer, exclusive of circuit losses in the RF and IF matching and filter networks, amounts to 5.3 dB.

For a PDR of 0.20 the junction resistance presented to the LO signal is  $0.75 R_{RF}$ , or 25 ohms in the present application. Because two diodes are connected in parallel on the LO side, the total real part of the LO impedance is 12.5 ohms. This low impedance is difficult to match into a coplanar stripline. The lowest impedance for CPS that can be conveniently realized on a 10-mil sapphire substrate, is 25 ohms.<sup>5</sup> However, because such a low CPS impedance would have lowered the cutoff frequency of the slotline mode in the CPS channel too much, an impedance of 35 ohms had to be chosen. Hence a VSWR of approximately 3:1 must be accepted if no further matching is provided. Such a VSWR is acceptable on the LO side, for it means less than 1.25 dB in mismatch loss. This approach was selected for the final mixer. A CPS taper then transforms the 35 ohms at the diodes into 80 ohms at the LO-to-waveguide transition. A possible matching network for the LO side that does not require CPS sections with impedances below 35 ohms is shown in Figure 10 (b). In this matching network, the impedance mismatch between the diodes and the 35-ohm CPS section is partially compensated by a half-wave section of a high characteristic impedance that is spaced a quarter wavelength from the diodes.

The theoretical VSWR for an optimized network with this topology is 1.5:1.

## REFERENCES

- 1.0 G. Spacek, "Stripguide Balanced Mixer," US Patent 3,584,306 (1970)
- 2.0 Final Report "K-Band Image-Reject and Ka-Band Balanced Mixers constructed using PLANAR Millimeter wave Techniques by Ashok K. Gorwara et al contract no= N00123-74-C-1957
- 3.0 A. Hislop and R.T. Kihm, "A Broadband 40-60 GHz Balanced Mixer," IFEK Trans on Microwave Theory and Techniques, Vol. MTT-24, pp.63-64 (January 1976).
- 4.0 E.A. Mariani et al, "Slot Line Characteristics," ZEEE Trans on Microwave Theory and Techniques, Vol. MTT-17, pp. 1091-1096 (December 1969).
- 5.0 M.R. Barber, " Figure and Conversion Loss of the Schottky Barrier Mixer Diode, " IEEE Trans on Microwave Theory and Technology, Vol. MTT-15 pp. (29-635 (Nov. 1967)
- 6.0 C.P Wen, "Coplanar Waveguide; A Surface Strip Transmission Line suitable for nonrecyprocal Geomagnetic Device Applications," IEEE Trans on Microwave Theory and Techniques, Vol. MTT-17, pp. 1087-1090 (December 1969.)