

AD-A041 528

OHIO STATE UNIV COLUMBUS ELECTROSCIENCE LAB
CO PROBE LASER FOR ATMOSPHERIC STUDIES.(U)

F/G 20/5

MAY 77 E K DAMON, M E THOMAS
ESL-4430-1

N00173-76-C-0233
NL

UNCLASSIFIED

| OF |
AD
A041528

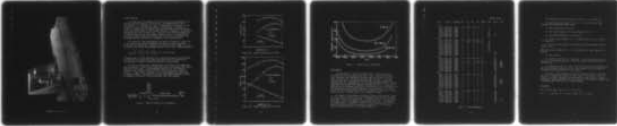
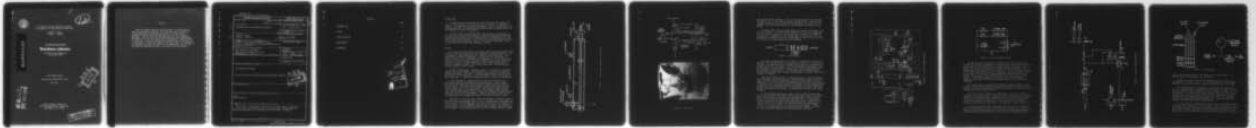

END
DATE
FILMED
7-77



CO PROBE LASER FOR ATMOSPHERIC STUDIES
Final Report - 20 May 1976 to 4 March 1977

Edward K. Damon
Michael E. Thomas

12

AD A 041528

The Ohio State University
ElectroScience Laboratory

Department of Electrical Engineering
Columbus, Ohio 43212

Final Report 4430-1
Contract No. N00173-76-C-0233
May 1977

DDC
PREPARED
JUN 12 1977
AD A 041528

AD No.
DDC FILE COPY

Naval Research Laboratory
4555 Overlook Avenue, South West
Washington, D.C. 20375

DISTRIBUTION STATEMENT A
Approved for public release;
Distribution Unlimited

NOTICES

When Government drawings, specifications, or other data are used for any purpose other than in connection with a definitely related Government procurement operation, the United States Government thereby incurs no responsibility nor any obligation whatsoever, and the fact that the Government may have formulated, furnished, or in any way supplied the said drawings, specifications, or other data, is not to be regarded by implication or otherwise as in any manner licensing the holder or any other person or corporation, or conveying any rights or permission to manufacture, use, or sell any patented invention that may in any way be related thereto.

UNCLASSIFIED

SECURITY CLASSIFICATION OF THIS PAGE (When Data Entered)

REPORT DOCUMENTATION PAGE		READ INSTRUCTIONS BEFORE COMPLETING FORM
1. REPORT NUMBER	2. GOVT ACCESSION NO.	3. RECIPIENT'S CATALOG NUMBER
	9 Final rept. 20 May 76-4 Mar 77	
4. TITLE (and Subtitle)	5. TYPE OF REPORT & PERIOD COVERED	
6 CO PROBE LASER FOR ATMOSPHERIC STUDIES,	Final - 5/20/76-3/4/77	
	14	6. PERFORMING ORG. REPORT NUMBER
		ESL-4430-1
7. AUTHOR(s)	8. CONTRACT OR GRANT NUMBER(s)	
10 Edward K./Damon Michael E./Thomas	15 N00173-76-C-0233	
9. PERFORMING ORGANIZATION NAME AND ADDRESS	10. PROGRAM ELEMENT, PROJECT, TASK AREA & WORK UNIT NUMBERS	
2 The Ohio State University ElectroScience Laboratory, Department of Electrical Engineering, Columbus, Ohio 43212		
11. CONTROLLING OFFICE NAME AND ADDRESS	12. REPORT DATE	
Naval Research Laboratory 4555 Overlook Avenue, South West Washington, D.C. 20375	11 May 1977	
14. MONITORING AGENCY NAME & ADDRESS (if different from Controlling Office)	13. NUMBER OF PAGES	
	14 12 17p.	
	15. SECURITY CLASS. (of this report)	
	Unclassified	
	15a. DECLASSIFICATION/DOWNGRADING SCHEDULE	
16. DISTRIBUTION STATEMENT (of this Report)		
Distribution unlimited		
17. DISTRIBUTION STATEMENT (of the abstract entered in Block 20, if different from Report)		
18. SUPPLEMENTARY NOTES		
19. KEY WORDS (Continue on reverse side if necessary and identify by block number)		
Laser Carbon Monoxide		
20. ABSTRACT (Continue on reverse side if necessary and identify by block number)		
The design, construction, and test of a CO probe laser is discussed. An electrically excited, flowing gas system was used. Output power of 360 mW was achieved in the 5-4 band, and 25 mW in the 3-2 band.		

D D C
 JUN 17 1977
 INSULATED
 C

462251

CONTENTS

	Page
INTRODUCTION	1
DESIGN	1
OUTPUT COUPLING	10
MEASUREMENTS	12
REFERENCES	14

White Section
Buff Section

PROCESSED
DATE
Letter on file

DISTRIBUTION/AVAILABILITY CODE
Dist. AVAIL. and/or SPECIAL

A

INTRODUCTION

The objective of this program was the construction and testing of a small, line-selectable, CO laser to be used as a probe for atmospheric studies. Its proposed end use placed certain limits on its physical size and configurations, its operational wavelength range and power output, and the placement of auxiliary equipment.

The basic system is patterned after that of Djeu [1], in which the entire active laser length is cooled to liquid nitrogen temperatures and a flowing helium flush is used to keep unexcited CO molecules out of the region beyond the electrodes. This reduces the self-absorption and allows lasing at the lower vibrational levels. These lower vibrational levels are particularly desirable for atmospheric studies.

DESIGN

The use of a helium flush in the plasma tube outside the active region requires a flowing system; sealed-off operation is thereby ruled out. As a consequence, some compromises can be made in vacuum integrity. A demountable system offers advantages in easing original fabrication, in later updating, and in salvagability of components in case of plasma tube failure. One system in use at The Ohio State University uses glass ball and socket joints. Although operational, these require some care to assure a reasonable vacuum. The O-ring joints used in the design here are far superior in this respect.

The basic plasma tube is shown in Figure 1. The tube is 1.2 meters between the end electrodes. The center arm is the vacuum port and also contains the anode. The anode is slightly above ground to allow current monitoring, but the potential is not high enough to cause a discharge to the vacuum pump. A long teflon bellows serves as a low-strain vacuum hose.

Liquid nitrogen is contained within a glass jacket which is eccentrically mounted with respect to the plasma tube. Glass bellows in the plasma tube compensate for differential thermal expansion between the two tubes. Four O-ring joint sidearms on the jacket allow for the liquid nitrogen fill, the level sensors, and gaseous nitrogen exhausts. These latter allow the cold exhaust gas to be conducted away from the laser and the experimental region, in case the consequent turbulence would interfere with optical measurements. Thermal insulation for the liquid nitrogen jacket is provided by an Armaflex 22 pipe insulation sleeve.

The detail of one of the gas inlets and cathodes is shown in Figure 2. The inner bore of the plasma tube is 13 mm. The diameter is kept small to minimize current requirements and to allow reasonable thermal contact with the discharge. This is expanded to 25 mm at the cathode. The cathode is nickel and has six pins hydrogen brazed to the discharge side to stabilize the discharge. The mixture of CO, N₂, and Xe is admitted through a nickel

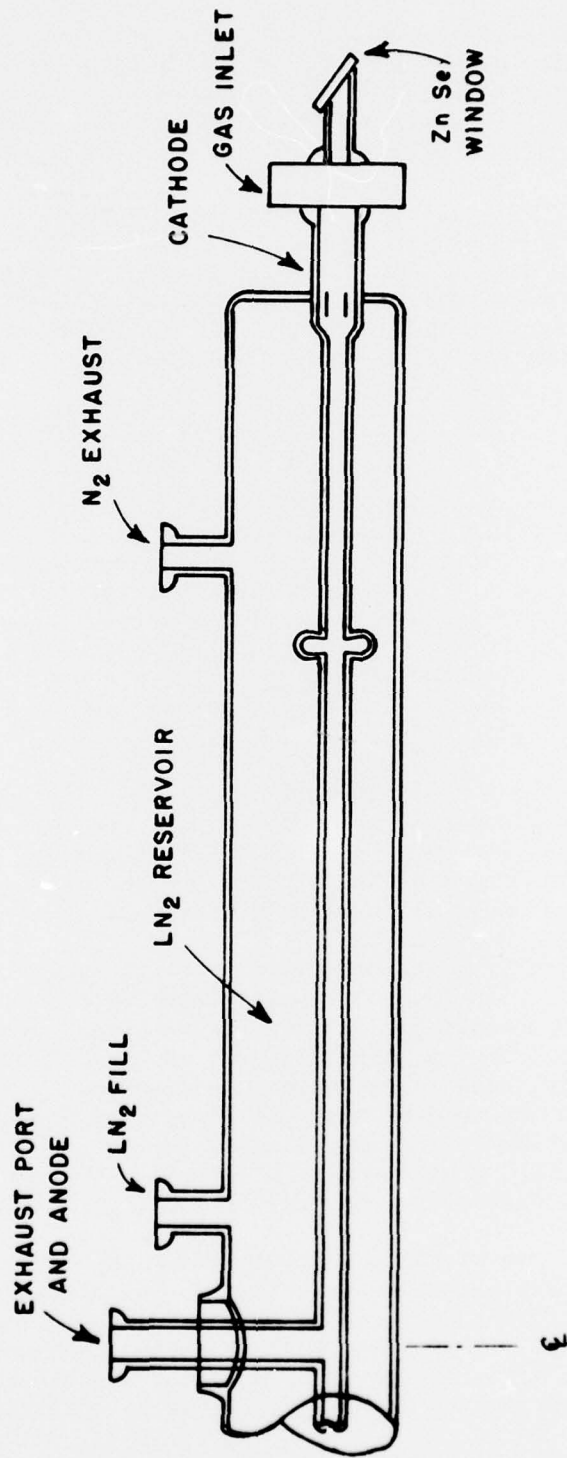

Figure 1. Laser plasma tube (one half shown).

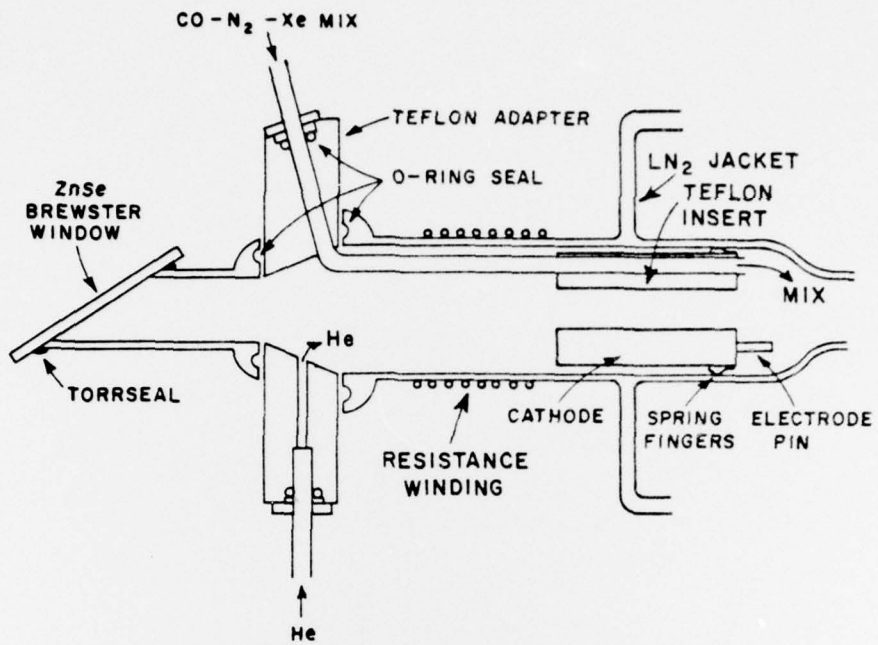

Figure 2. End detail

tube brazed into the cathode. The He in the active length flows through the central hole in the cathode from the flushed volume. The tube used to admit the gas mixture also serves for the electrical contact to the cathode. The teflon piece adapts the tube diameters and mounts the gas inlets.

The ends of the liquid nitrogen jacket are sealed to the plasma tube near the cathodes. To prevent frost formation on the output windows and to keep the O-ring joints at room temperature, a length of nichrome resistance wire is wound on the plasma tube near the insulation. The 500 ohm winding is energized by a 36 V transformer as shown in Figure 3, with the resulting 2.6 watts preventing these problems.

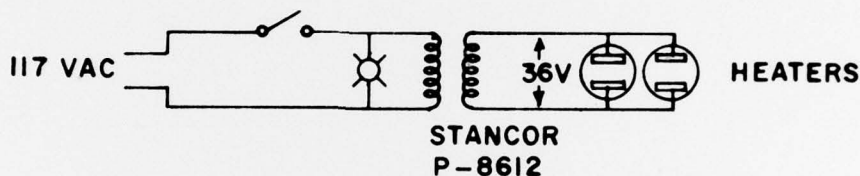

Figure 3. Tube heaters.

The liquid nitrogen level in the jacket is automatically controlled through a Torr Vacuum Products L-21K two-level controller. The high and low levels are adjusted by the placement of the sensors inserted through a flanged side arm in the jacket. The liquid nitrogen enters another side arm through a TL-103 antisplash fitting, with the flow controlled by a TL-207 liquid nitrogen valve. A TL-107 valve could be substituted if operation by pressurizing a standard storage dewar is desired. The circuit is shown in Figure 4.

The laser discharge circuit is shown in Figure 5. The two cathodes have individual $1\text{ M}\Omega$ ballast strings. Although this amount of ballast is larger than necessary to handle any negative resistance effects of the discharge, it is very useful when establishing the CO flow. The discharge is very sensitive to the small amounts of CO used, and the discharge will frequently be lost from CO surges if a small ballast is used. The large ballast also improves stability as the discharge is cooled by the liquid nitrogen.

If the discharge does go out, there is the possibility that ozone formation could have taken place, and the ozone can liquefy on the tube walls. Reinitiation of the discharge has been known to cause a minor explosion with consequent breakage of the plasma tube. To prevent this, the loss of current is sensed at the anode and the high voltage (and liquid nitrogen fill) turned off through the interlock system shown in Figure 6. If the gas flow is shut off and the tube pumped to below 0.1 Torr for several minutes, this ozone should be removed. Gas flow can then be reestablished and the discharge safely restarted.

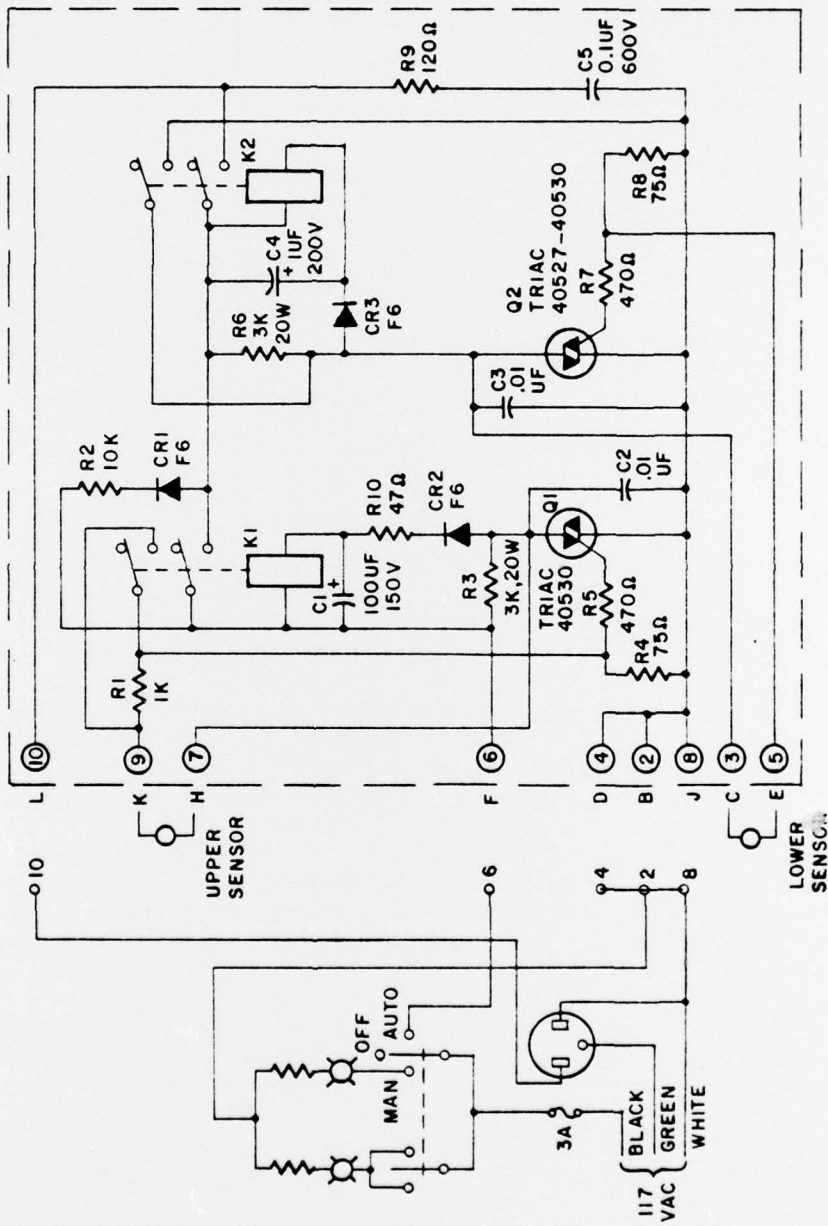

Figure 4. Liquid nitrogen control.

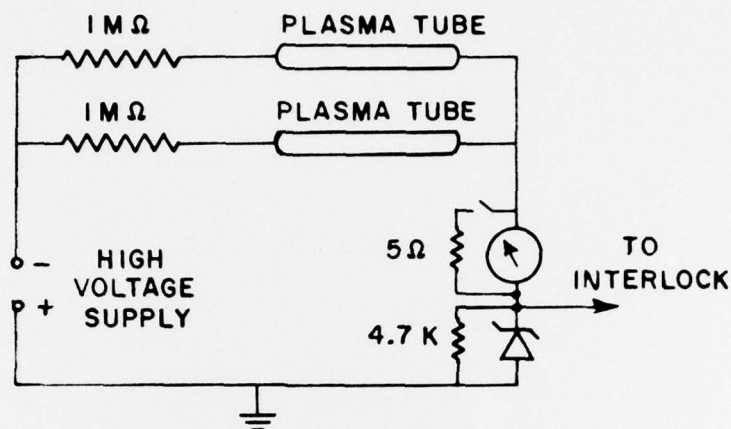

Figure 5. Laser discharge circuit.

The gas handling is indicated schematically in Figure 7. The individual gas flows are monitored by a Matheson four-tube rotameter with NRS valves used for setting the flows. A manual toggle switch allows any of the gases to be shut off without disturbing the flow adjustment. The helium flows through two small teflon tubes to flush the inactive portions of the laser tube, and from there into the active discharge region. The CO, N₂, and Xe are mixed in a small manifold and then the mixture flows through similar tubes to the cathodes and directly into the active discharge. As mentioned previously, these tubes are long and of small diameter to prevent an electrical discharge between the cathode and the flowmeter.

The vacuum pump is connected to the central sidearm through a teflon bellows. The gas manifold panel also contains a throttling valve (Whitey SS8RF8) for the pump and a gauge (Wallace & Tiernan) for setting the pressure in the plasma tube (normally 7 Torr).

The laser cavity is formed by a ZnSe output mirror of 5 m radius of curvature and a plane grating. The plasma tube is sealed with ZnSe Brewster windows. The aluminum plates supporting the optics are mounted on four Invar rods for thermal stability, and the plasma tube and connections to it are also supported by these rods. A housing above the structure furnishes some mechanical protection. The assembly is shown in Figure 8.

The plasma tube and optical components are mounted in a frame using four one inch diameter, 6 foot long, Invar rods for stability. At the output, an aluminum plate mounts a Burleigh SG-201 Gimbal Mount containing a Burleigh PZ-80 Aligner/Translator, used for both fine angular control

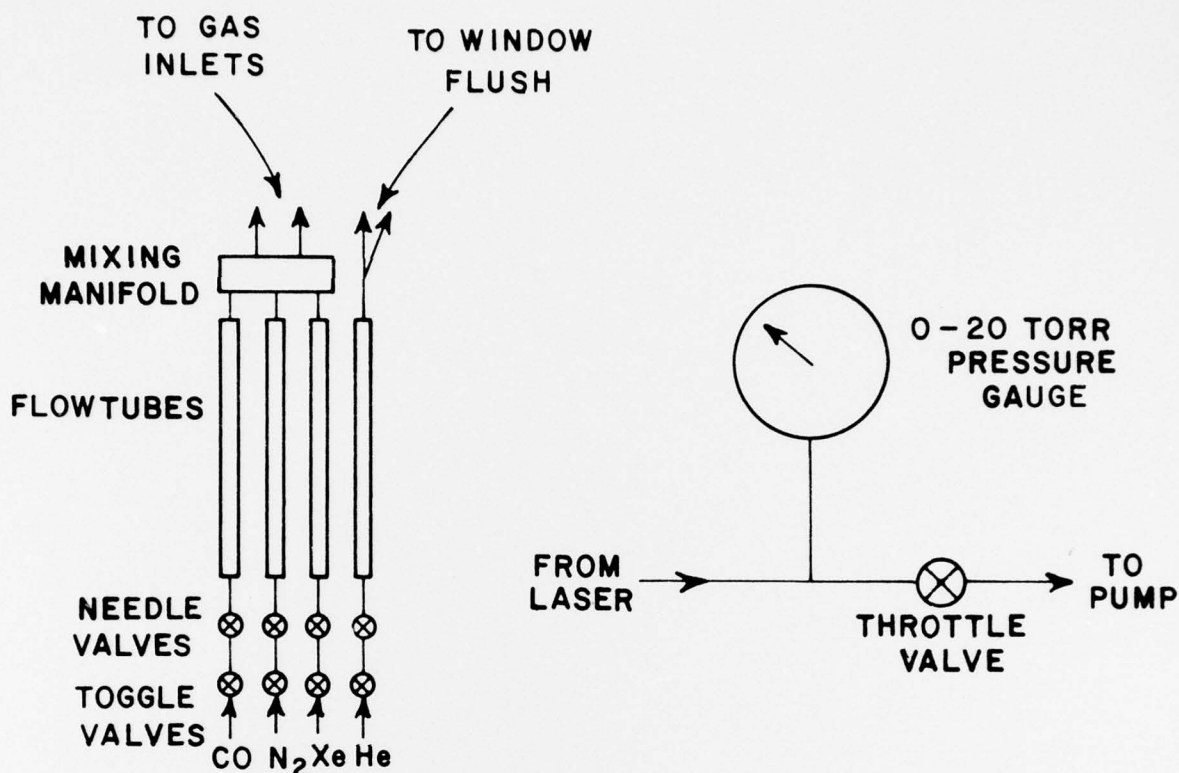

Figure 7. Gas manifold.

and for cavity length tuning. The output mirrors are mounted in individual cups that screw onto the translator.

Between the output mirror and the adjacent Brewster window is an adjustable iris on an x-y stage. This is employed both as an alignment aid and a stop to assure single transverse mode operation of the laser.

The grating mount is an adaptation of an ESL design. Wavelength tuning is accomplished by a Starrett T465 micrometer. Through a tangent arm, this rotates a shaft supported by thrust-loaded ball bearings. The grating table is clamped to this shaft, and has adjustments for tilting the grating so that it is parallel to the shaft, and for rotating the grating so that its grooves are also parallel to the shaft. Properly aligned, the complete CO wavelength range may be covered by adjusting only the micrometer and the PZT length control.

The teflon adapters between the plasma tube and the Brewster windows furnish the main support for the plasma tube. They are fastened to the frame with a flexure strip mount to allow the tube to contract when cooled with liquid nitrogen. This motion is approximately 0.024 inch at each end, and does not contribute any significant vertical motion to the tube.

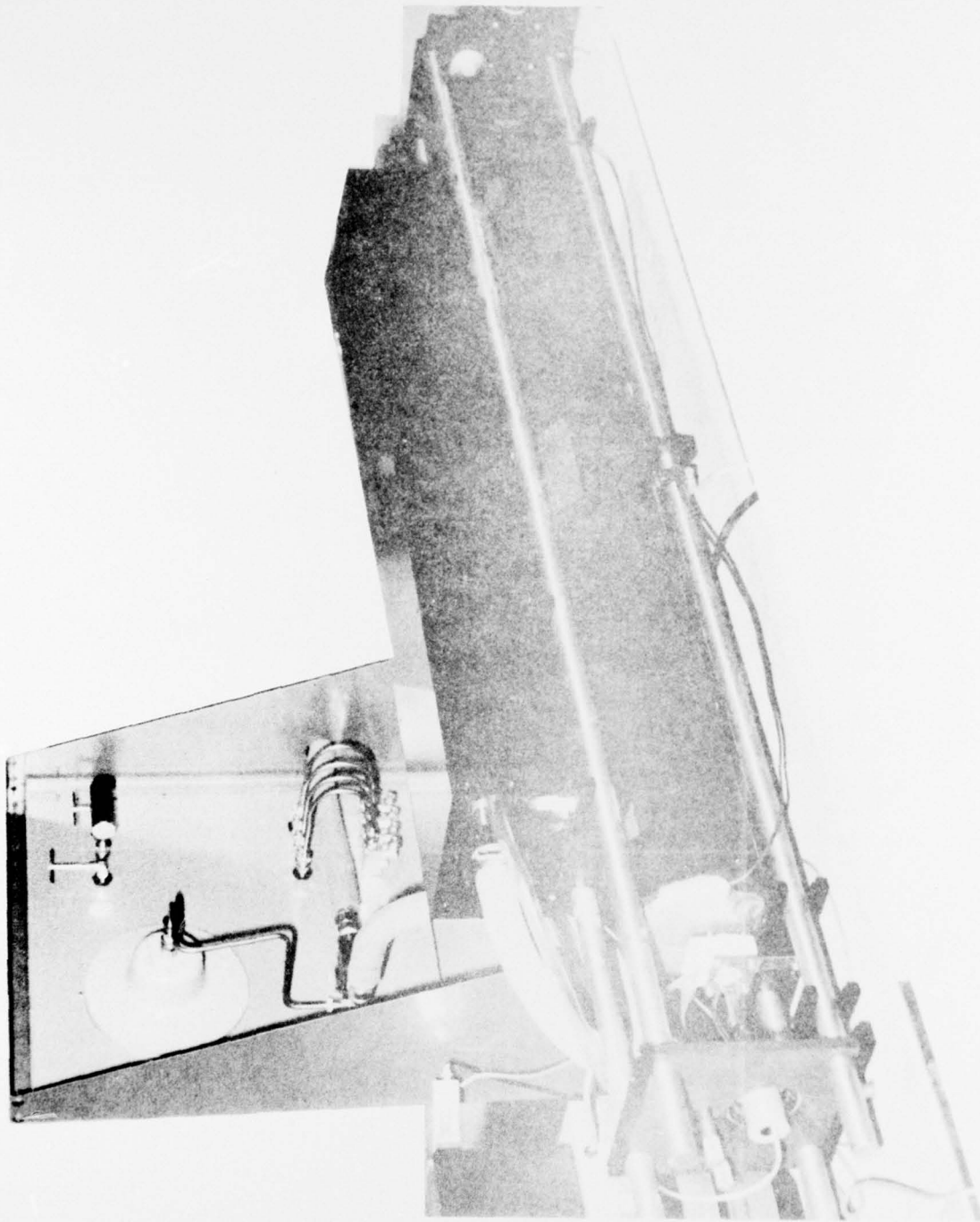

Figure 8. Laser assembly.

OUTPUT COUPLING

The selection of the output mirror reflectivity was performed on the similar CO laser currently in use at OSU. The method used was that described by T. F. Johnston, Jr. [2]. A high reflectivity mirror is used on the laser cavity so that the output is undercoupled. As shown in Figure 9, a knife edge is inserted into the laser beam inside the optical cavity and reflects some of the internal energy to a detector. An aluminum-coated cube was used in these tests. The sum of the reflected energy and the normal output is the total output coupling, and this is optimized by inserting the knife edge into the beam until this sum is maximized. The technique obviates the need for a sequence of calibrated mirrors.

The results of these measurements are shown in Figure 10. Figure 10a is for the 4-3 P(6) transition and for the particular flow conditions 94 mW could be coupled out, compared to 51 mW with no knife edge. At this transition, the mirror has a transmission of 2.9 per cent. Optimum coupling

$$t_{\text{opt}} = \left(1 + \frac{P_s}{P_1}\right) t = \left(1 + \frac{71}{22}\right) (2.9) = 12.2 \text{ per cent}$$

although there is little difference for couplings between 9 and 15 percent. For the 5-4 P(12) transitions, where the output mirror transmission is approximately 2 percent, 12 percent coupling is again optimum.

For use as a probe laser, maximum power is frequently less important than the ability to lase on the transitions further from band center, where the gain will be lower. Interchangeable output mirrors are therefore employed, with reflectivities of 91, 96.5, and 99 percent as shown in Figure 11. These allow a tradeoff in the field between power and number of lines available. The output mirrors are individually mounted in screw-on adapters, and require little realignment when interchanged.

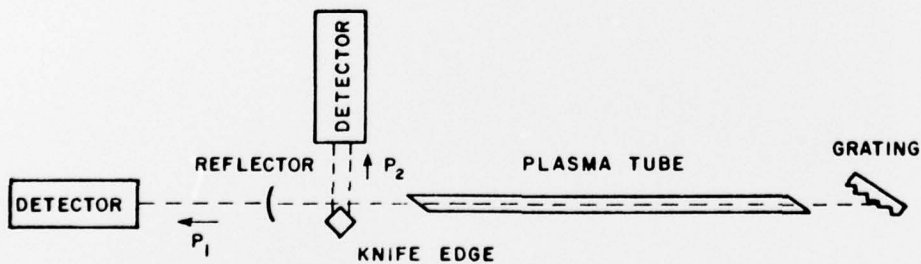

Figure 9. Output coupling test arrangement.

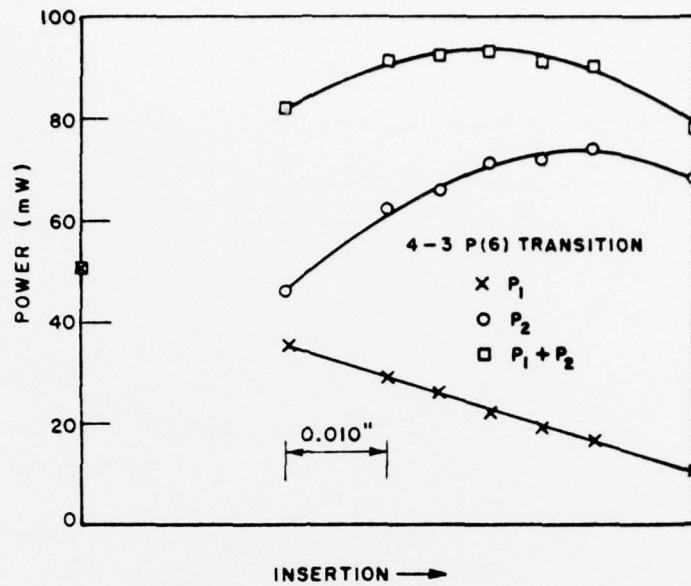

Figure 10a. Output coupling for 4-3 P(6).

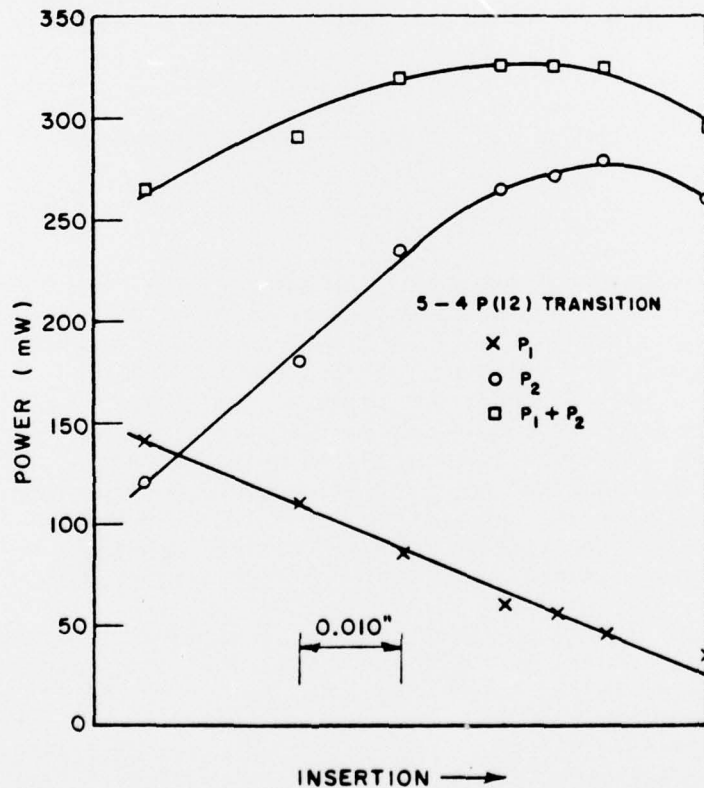

Figure 10b. Output coupling for 5-4 P(12).

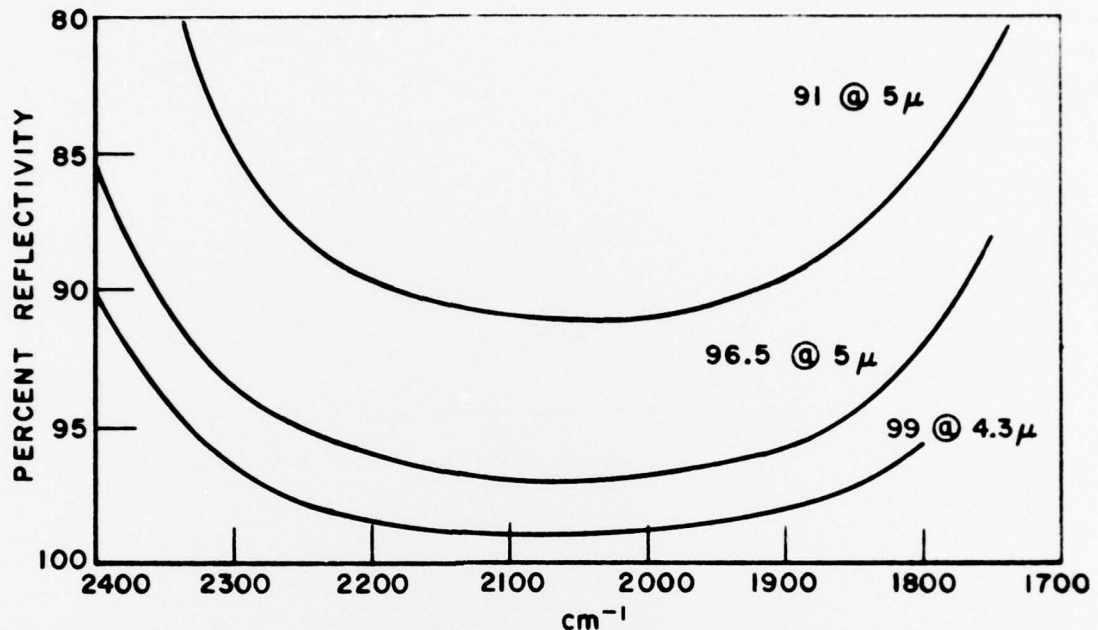

Figure 11. Output mirror reflectivity.

MEASUREMENTS

The performance of the new 1.2 meter laser is shown in Table I. This data was all for a tube pressure of 7 Torr. Flow readings were with a Matheson 7462 Rotameter with #602 tubes for He and N₂ and #610 tubes for Xe and CO. Gas supply pressure was 2-5 PSIG. It has been our experience with the previous CO laser that performance gradually improves with use, presumably due to tube and electrode cleanup. Optimum conditions may therefore be expected to change with time. In addition, optimization was somewhat noncritical, and changes in operating conditions were generally made only when there was a clear advantage. The laser should run well on bands higher than 7-6, although these were not tested because of their limited interest for atmospheric studies.

The trends in the performance data are towards lower current, lower CO flows, and more Xe for the lower vibrational bands and for the lower rotational lines in the lower bands. In addition, the 4-3 and 3-2 bands were lower in gain, and needed the 99 percent reflector. At midband on the higher bands, a 91 percent reflector was much better than the 96.5 percent reflector used for the higher or lower lines. Time did not permit the determination of the optimum coupling.

Line	(cm ⁻¹)	Setting	He	N ₂	Xe	CO	I(mA)	Output in mW		
								99%	96.5%	91%
3-2										
P(7)	2063.225	3750	3.2	138	>100	43	8	2		
P(8)	2059.209	3805	↓	↓	↓	↓	↓	5		
P(9)	2055.159	3859	↓	↓	↓	↓	↓	5		
P(10)	2051.076	3914	↓	↓	↓	↓	↓	10		
P(11)	2046.959	3971	↓	↓	↓	↓	↓	10	25	
P(12)	2042.809	4029	↓	↓	↓	↓	↓	10		
4-3										
P(6)	2041.070	4049	3.1	130	100	30	8	2		
P(7)	2037.123	4104	3	131	97	50	10	5		
P(8)	2033.142	4157	↓	↓	↓	↓	↓	10		
P(9)	2029.178	4214	↓	↓	↓	↓	↓	15		
P(10)	2025.079	4274	↓	↓	↓	↓	↓	25		
P(11)	2020.997	4328	↓	↓	↓	↓	↓	17		
P(12)	2016.882	4390	↓	↓	↓	↓	↓	15		
P(13)	2012.734	4450	↓	↓	↓	↓	↓		35	
P(14)	2008.552	4509	↓	↓	↓	↓	↓		35	
5-4										
P(8)	2007.145	4530	3.1	126	100	50	12		20	
P(9)	2003.165	4588	↓	↓	↓	↓	↓		50	
P(10)	1999.152	4645	3.1	126	95	98	12.5		105	280
P(11)	1995.105	4704	↓	↓	↓	↓	↓		120	360
P(12)	1991.025	4764	↓	↓	↓	↓	↓		60	200
P(13)	1986.911	4825	↓	↓	↓	↓	↓		65	100
P(14)	1982.765	4889	↓	↓	↓	↓	↓		65	
P(15)	1978.585	4953	↓	↓	↓	↓	↓		30	
6-5										
P(8)	1981.219	4913	2.3	130	93	72	14		10	
P(9)	1977.274	4971	↓	↓	↓	↓	↓		50	
P(10)	1973.296	5031	↓	↓	↓	↓	↓		65	
P(11)	1969.284	5094	↓	↓	↓	↓	↓		85	225
P(12)	1965.239	5156	↓	↓	↓	↓	↓		100	220
P(13)	1961.160	5220	↓	↓	↓	↓	↓		75	120
P(14)	1957.049	5283	↓	↓	↓	↓	↓		100	
P(15)	1952.904	5347	↓	↓	↓	↓	↓		65	
7-6										
P(7)	1959.241	5248	2.3	130	93	72	14		15	
P(8)	1955.365	5308	↓	↓	↓	↓	↓		40	
P(9)	1951.456	5370	↓	↓	↓	↓	↓		60	
P(10)	1947.512	5434	↓	↓	↓	↓	↓		80	
P(11)	1943.535	5493	↓	↓	↓	↓	↓		50	
P(12)	1939.525	5561	↓	↓	↓	↓	↓		50	210
P(13)	1935.482	5628	↓	↓	↓	↓	↓		80	

Table I. Laser Parameters.

The following start-up procedure was used for laser operation:

- 1) Pump tube to less than 0.1 Torr. It is preferable to keep plasma tube at mechanical pump vacuum.
- 2) Set gas flow for 4 Torr He.
- 3) Set current control to 12 mA, voltage to 16 KV.
- 4) Initiate discharge by turning HV on.
- 5) Start liquid nitrogen fill. Discharge must be on to activate fill interlock.
- 6) Set He and N₂ to desired flow rates with tube pressure approximately 7 Torr.

When the liquid nitrogen fill cycle is complete, and laser operation is desired

- 7) Set Xe level.
- 8) Carefully add CO to desired level. If discharge goes out, turn off gases at switches, pump to 0.1 Torr for several minutes, and then restart cycle.
- 9) With grating set to desired line, vary common PZT voltage to peak the cavity length to maximum output. Small changes in PZT alignment or grating position may now optimize the output.

The laser is most conveniently put in a standby mode by turning off the xenon, although the CO may also be turned off if desired. When the laser is shut down, the tube should be kept at vacuum until the liquid nitrogen is gone to prevent convective cooling of the windows. Maintaining a discharge helps boil off the liquid nitrogen.

REFERENCES

- [1] N. Djeu, Appl. Phys. Lett 23, 309 (1973).
- [2] T. F. Johnston, Jr., J. Quant. Elect. 12, 310 (1976).