

AD A 041675

AFAL-TR-76-79



2

CREW SIZE EVALUATION FOR TACTICAL ALL-WEATHER STRIKE AIRCRAFT

*DISPLAY SYSTEMS AND HUMAN FACTORS DEPARTMENT
HUGHES AIRCRAFT COMPANY
CENTINELA & TEALE STS
CULVER CITY, CALIF. 90230*

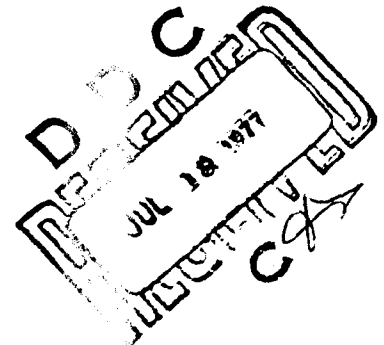

APRIL 1977

TECHNICAL REPORT AFAL-TR-76-79
FINAL REPORT FOR PERIOD APRIL 1975 TO JULY 1975

Approved for public release; distribution unlimited

AD NO. _____
DDC FILE COPY

AIR FORCE AVIONICS LABORATORY
AIR FORCE WRIGHT AERONAUTICAL LABORATORIES
AIR FORCE SYSTEMS COMMAND
WRIGHT-PATTERSON AIR FORCE BASE, OHIO 45433

NOTICES

When Government drawings, specifications, or other data are used for any purpose other than in connection with a definitely related Government procurement operation, the United States Government thereby incurs no responsibility nor any obligation whatsoever; and the fact that the government may have formulated, furnished, or in any way supplied the said drawings, specifications, or other data, is not to be regarded by implication or otherwise as in any manner licensing the holder or any other person or corporation, or conveying any rights or permission to manufacture, use, or sell any patented invention that may in any way be related thereto.

This report has been reviewed by the Information Office (OI) and releasable to the National Technical Information Service (NTIS). At NTIS, it will be available to the general public, including foreign nationals.

This technical report has been reviewed and is approved for publication.

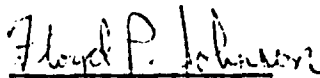
FLOYD P. JOHNSON
Project Engineer

FOR THE COMMANDER

CHARLES L. HUDSON, Colonel, USAF
Chief, Reconnaissance and Weapon
Delivery Division

Copies of this report should not be returned unless return is required by security considerations, contractual obligations, or notice on a specific document.

UNCLASSIFIED

SECURITY CLASSIFICATION OF THIS PAGE (When Data Entered)

REPORT DOCUMENTATION PAGE		READ INSTRUCTIONS BEFORE COMPLETING FORM
1. REPORT NUMBER AFAL-TR-76-79	2. GOVT ACCESSION NO.	3. RECIPIENT'S CATALOG NUMBER
4. TITLE (and Subtitle) CREW SIZE EVALUATION FOR TACTICAL ALL-WEATHER STRIKE AIRCRAFT	5. TYPE OF REPORT & PERIOD COVERED Final Technical Report, Apr 1975 - Jul 1975	6. PERFORMING ORG. REPORT NUMBER D4163, P76-48R
7. AUTHOR(s) M. L. Hershberger, L. A. Scanlan and D. W. Craig	8. CONTRACT OR GRANT NUMBER(s) F33615-75-C-1126	
9. PERFORMING ORGANIZATION NAME AND ADDRESS Hughes Aircraft Company Display Systems and Human Factors Department Culver City, California 90230	10. PROGRAM ELEMENT, PROJECT, TASK AREA & WORK UNIT NUMBERS Project 7622 Task 03 42 03	
11. CONTROLLING OFFICE NAME AND ADDRESS Air Force Avionics Laboratory, (RWT-3) Wright-Patterson Air Force Base, Ohio	12. REPORT DATE Apr 1977	
14. MONITORING AGENCY NAME & ADDRESS (if different from Controlling Office) 12 88 p.	13. NUMBER OF PAGES 78	15. SECURITY CLASS. (of this report) Unclassified
16. DISTRIBUTION STATEMENT (of this Report) Approved for public release; distribution unlimited		
17. DISTRIBUTION STATEMENT (of the abstract entered in Block 20, if different from Report) HAC-D4163-1-P76-48R		
18. SUPPLEMENTARY NOTES		
19. KEY WORDS (Continue on reverse side if necessary and identify by block number) Aircrew Performance Crew Size Synthetic Aperture Radar Radar Operator Performance		
20. ABSTRACT (Continue on reverse side if necessary and identify by block number) This research and development obtained significant information necessary to assess the requirements for one- versus two-man aircraft in air-to-ground strike missions using synthetic aperture radar (SAR). A real-time man-in-the-loop simulation was conducted in which one- and two-man TAC crews performed aircraft flight control, aircraft systems management, communications, threat detection, countermeasures, and SAR target		

DDC
RECEIVED
JUL 18 1977
LIBRARY

405 763

UNCLASSIFIED

SECURITY CLASSIFICATION OF THIS PAGE(When Data Entered)

Block 20 (continued)

acquisition tasks. Threat detection and response tasks were employed to vary crew workload and to create inside-cockpit and outside-cockpit visual tasks. A shallow interdiction air-to-ground strike mission with ingress to enemy territory, penetration of enemy territory, and SAR tactical target acquisition phases was simulated. One- and two-man aircrew flight control performance, threat detection and response, and SAR target acquisition performance were measured. Two-man crews were superior to one-man crews for aircraft flight control performance. This superiority became more pronounced as threat density (workload) increased. There was no difference between one- and two-man crews for the inside-cockpit threat detection and response tasks. A large difference in favor of two-man crews was obtained for outside-cockpit threat detection performance. Slightly better SAR target acquisition performance was obtained with two-man crews except at the highest threat density where the one-man crews were substantially better. The one-man crews largely ignored outside-cockpit threats at the highest threat level. Thus, SAR target acquisition performance improved for one-man crews at the expense of threat detection and response performance. In general, two-man crews were superior to one-man crews at aircraft flight control, outside-cockpit threat detection, and SAR target acquisition tasks. The dominant superiority of two-man crews, however, was for outside-cockpit threat detection. A major advantage for a two-place SAR air-to-ground strike aircraft, therefore, is the improved visual surveillance achieved with two crewmen and the resulting increased survivability when over hostile enemy territory. The detailed simulation procedures and results of this work and the implications to advanced synthetic aperture radar airborne strike systems are discussed in the report.

UNCLASSIFIED

SECURITY CLASSIFICATION OF THIS PAGE(When Data Entered)

PREFACE

This study was initiated by the Air Force Avionics Laboratory, Wright-Patterson Air Force Base, Ohio, to investigate crew size requirements for tactical all-weather strike aircraft. The research was conducted by the Display Systems and Human Factors Department of Hughes Aircraft Company, Culver City, California, under USAF contract F33615-75-C-1126. The contract was initiated under Project 7622, Synthetic Aperture Radar Operator Performance, Task 03, Mr. F. P. Johnson (AFAL/RWT-3) was the Air Force Project Engineer. Mr. D. W. Craig of Hughes Aircraft Company was Project Manager. The research sponsored by this contract was initiated in April 1975 and completed July 1975. This report was submitted by the authors January 1976.

Special acknowledgement is gratefully made of the following people without whose help the research could not have been accomplished. Mr. F. P. Johnson who, in addition to serving as the Air Force Project Engineer, spent considerable time and effort working with Hughes and Air Force personnel on many technical problems. Majors S. R. Weaver and K. H. Kenworthy of TFWC, Nellis Air Force Base, Nevada provided the skills and expertise necessary to frame a realistic simulation of a TAC air-to-ground strike mission and coordinated efforts necessary to check out simulation procedures and schedule TAC crews.

We would also like to express our appreciation to the 30 pilots and weapons system officers who each devoted two days of their time at Hughes serving as crewmen in the research.

The contractor's report number is D4163.

ACCESSION for	
NTIS	White Section <input checked="" type="checkbox"/>
DDC	Buff Section <input type="checkbox"/>
UNANNOUNCED	<input type="checkbox"/>
JUSTIFICATION.....	
.....	
.....	
DISTRIBUTION/AVAILABILITY CODES	
Dist.	AVAIL. and/or SPECIAL
M	

TABLE OF CONTENTS

1.	INTRODUCTION AND SUMMARY	1
	Introduction	1
	Summary	6
2.	SIMULATION METHODOLOGY	13
	Mission Profiles	13
	Cockpit Configurations	15
	One-man Cockpit	15
	Two-man Cockpit	23
	Simulation Equipment	23
	Operator Tasks	27
	Research Design	29
	Variable Levels	30
	Subjects	30
	Performance Measures	31
	Procedures	31
	Ground Map Radar Imagery	39
3.	RESULTS AND DISCUSSION	41
	Aircraft Flight Control Performance	41
	Threat Detection and Response Performance	45
	RWR Threat Response	45
	RWR Outside Light Detection	46
	Non-RWR Outside Light Detection	48
	Air-to-Air Radar Target Threats	50
	Comparison of Inside and Outside Cockpit Threat Response Performance	51
	Overall Threat Detection and Response Performance	54
	SAR Ground Map Target Acquisition Performance	56

TABLE OF CONTENTS (Continued)

4.	CONCLUSIONS AND RECOMMENDATIONS	60
	Aircraft Flight Control Performance	60
	Threat Detection and Response Performance	61
	Synthetic Aperture Radar Target Acquisition Performance	62
	Recommendations for Future Crew Size Research	63
	Total System Considerations	63
	Man-Machine System Model	64
	Model Validity	66
	APPENDIX A. SAR TARGET TEST SCENES USED IN THE SIMULATION	67
	APPENDIX B. ANALYSIS OF VARIANCE SUMMARY TABLES	73
	REFERENCES	78

LIST OF ILLUSTRATIONS

Figure		Page
1	Effects of Threat Density and Crew Size on Aircraft Altitude Control Performance	9
2	Effects of Threat Density and Crew Size on Aircraft Heading Control Performance	9
3	Comparison of Inside and Outside Cockpit Threats for One- and Two-man Crews and Threat Densities in the SAR Target Acquisition Mission Phase	10
4	Crew Size and Threat Density Effects on Time to Acquire SAR Targets	11
5	Crew Size, Threat Density, and Probability of Target Acquisition	12
6	Shallow Interdiction Mission Profile	14
7	Single-seat Cockpit Configuration	16
8	Flight and Navigation Symbology on Multi-mode Display . . .	17
9	Air-to-Air Radar Search Symbology on Multi-mode Display	18
10	Air-to-Air Radar Lock-on Symbology on Multi-mode Display	19
11	Radar Video and Symbology on Multi-mode Display	20
12	Radar Warning Receiver and Threat Bearing Indicator	21
13	Countermeasures Control Panel	21
14	Cockpits used for the Two-man Cockpit Configuration	24
15	Simulation Equipment Block Diagram	25
16	Outside Cockpit Threat Set-up	26
17	Threat Densities and Distributions	30
18	Two Examples of SAR Target Scenes	39
19	Crew size Effects on Aircraft Altitude Control	42
20	Crew size Effects on Aircraft Heading Control	42
21	Effects of Threat Density and Crew Size on Aircraft Altitude Control Performance	44

LIST OF ILLUSTRATIONS (Continued)

Figure		Page
22	Effects of Threat Density and Crew Size on Aircraft Heading Control Performance	44
23	Crew Size Effects on RWR Threat Response Performance	46
24	Threat Density and Mission Phase Effects on RWR Threat Response Performance	46
25	Effect of Crew Size on RWR Outside Light Detection Performance	47
26	Mission Phase Effects on RWR Outside Light Detection Performance	47
27	RWR Outside Light Detection Performance and Threat Density	48
28	Crew Size Effects on Detection of Non-RWR Outside Lights	49
29	Mission Phase Effects on Detection of Non-RWR Outside Lights	49
30	Effect of Threat Density on Detection of Non-RWR Outside Lights	50
31	Effect of Crew Size on Air-to-Air Radar Threat Detection Performance	50
32	Effect of Threat Density on Air-to-Air Radar Target Threat Detection Performance	51
33	Comparison of Inside- and Outside-Cockpit Threats for One- and Two-Man Crews and Threat Densities in the Penetration Mission Phase	52
34	Comparison of Inside- and Outside-Cockpit Threats for One- and Two-Man Crews and Threat Densities in the SAR Target Acquisition Mission Phase	53
35	Overall Effects of Threat Density on Threat Detection and Response Performance	55
36	Crew Size and Threat Density Effects on Time to Acquire SAR Targets	57
37	Crew Size, Threat Density, and Probability of Correct SAR Target Acquisition	58
38	Man-Machine System Model	64

LIST OF ILLUSTRATIONS (Continued)

Figure	Page
A-1 Test Target Number 1	68
A-2 Test Target Number 2	68
A-3 Test Target Number 3	69
A-4 Test Target Number 4	69
A-5 Test Target Number 5	70
A-6 Test Target Number 6	70
A-7 Test Target Number 7	71
A-8 Test Target Number 8	71
A-9 Test Target Number 9	72
A-10 Test Target Number 10	72

SECTION 1

INTRODUCTION AND SUMMARY

INTRODUCTION

The research effort reported herein is part of a continuing effort by the Air Force Avionics Laboratory to gain information on operator performance using high resolution, ground mapping, synthetic aperture radar systems. Early operator performance research efforts in the mid- and late 1960s were directed principally towards real-time strike of large fixed targets. In the early and mid-1970s, the research shifted towards the problems of the real-time, tactical target, strike mission. This change of emphasis was due to the technological development of synthetic aperture radar (SAR) which has made the imaging of small tactical targets (e. g., tanks, trucks, and SAM sites) on SAR ground maps a reality.

The SAR operator performance research that has been conducted during the past 10 years has been oriented towards parametric studies of radar system parameters, display presentation parameters, types of briefing and reference material aids, types of strike missions, and general operator performance estimation (Hershberger and Carel, 1967; Carel and Hershberger, 1967; Hershberger and Craig, 1970; Hershberger and Craig, 1972; Craig and Hershberger, 1974). Nearly all of this past research was conducted using single operators who had sole responsibility for interpreting the radar image, performing radar mode switching functions, and designating the radar target aimpoint. The operators in the research studies had no other task responsibility or workload. Past research has, therefore, implicitly assumed a multiple crew aircraft.

The radar operators in past SAR operator performance research have not been responsible for aircraft flight control or aircraft systems management. For SAC, this assumption is valid; for TAC where both single- and two-seat aircraft could be used for all-weather strike missions employing an advanced air-to-ground SAR system, the assumption is not necessarily valid.

By 1980, the principal TAC aircraft which might be considered for a SAR strike system are the F-4, F-111, F-15, and F-16. Thus TAC might want to use either single- or two-seat aircraft with a SAR system. For TAC, then, the question of a single pilot/radar operator's ability to both control aircraft systems and successfully recognize and designate radar targets in a limited time profile is of major importance.

The issue of one- versus two-seat strike aircraft has been argued for many years by both Air Force and Navy air forces with strong advocates for both positions. Surprisingly little definitive work has been done to resolve the issue of one- versus two-man air-to-ground strike aircraft. The most comprehensive study was done by the Boeing Company (1967 and 1968).

Boeing conducted an extensive analysis and simulation for the Navy's Multimission Fighter/Attack Aircraft concept. Advanced system concepts for alternate cockpit configurations of one- versus two-place multi-mission aircraft for the 1972-1975 time period were evaluated. The results of the analysis are summarized in the following quotation:

The two-place multi-mission fighter/attack aircraft system appears, at this time, to provide the best probability of mission success. Both the one- and two-man configurations appear satisfactory for successful completion of the multi-mission role under normal operating conditions. However, the two-place has advantages if degraded-mode operations are required, and could improve target acquisition performance under any mission situation.

The Boeing laboratory simulation compared one-versus two-place aircraft for the primary task of visual ground target acquisition with secondary tasks of flight systems management, weapon delivery, and navigation system update. The results revealed that the two-man crew visually acquired the test targets at a greater range than one-man crews. There was no difference in probability of target acquisition. There was generally little difference between the one- and two-man crews in the secondary performance measures.

It appears from the Boeing work that a two-man crew can visually acquire prebriefed ground targets sooner than a one-man crew — about 1 second at a 200 foot altitude and Mach 0.9 aircraft speed — and a two-man

crew offers better mission reliability than the one-man crew because the second man can share tasks when failures occur. For standard flight control and aircraft systems management tasks, a one-man crew can function as effectively as a two-man crew. The major criticisms of the Boeing work were the lack of any out-of-cockpit visual tasks other than the visual target acquisition task and the failure to vary crew workload in a controlled manner over a large range.

The Autonetics Division of the North American Rockwell Corporation (1967) did an analytical study of one-man crew effectiveness for the F-X fighter aircraft. Analytical models were used to provide quantitative evaluation of mission effectiveness for fighter screen, point intercept, day interdiction, and all-weather strike missions. The general results and conclusions of the Autonetics study are summarized in the following statements:

1. A one-man F-X system, optimized for air-to-air missions, will be able to perform typical air-to-ground missions effectively.
2. The controls and displays necessary to operate and monitor the F-X system can be fitted into a one-man cockpit.
3. The performance of the F-X system shows reduced dependence on crew size and crew performance.
4. The F-X system will not present serious problems to a one-man crew in the areas of preflight, takeoff, cruising flight, or approach and landing.
5. F-X system capability and flexibility is achieved by a high degree of utility of the air-to-air systems in all modes, system mode centralization and display information integration, and by increased automation and advanced technology.

The Autonetics study concludes that a one-man crew will be able to adequately operate the F-X aircraft without being overloaded. The study did not consider degraded mode operation. An interesting side light of the study was a series of interviews with Air Force combat flying personnel. These people stated that a two-man crew is desirable when:

1. flying CAP missions for extended radar detection range,
2. flying difficult low altitude air-to-surface missions involving complex manual navigation, and
3. partial equipment failures occur and one man can not handle all backup modes.

Hughes Aircraft Company (1969) did a one-man/two-man tradeoff during its Phase 1A work on the F-15 aircraft. The conclusion arrived at during this study was that two men could more fully exploit the potential of the avionics system than one man. However, the life cycle cost impact of the additional automatic features which must be added to improve the performance of a one-man system is not significant when compared with the significant penalties on the aircraft of adding a second man. By providing target signature to B-scan radar presentation using a digitally augmented detection system, automated counter-countermeasures, precision inertial navigation, and a preset/cocked system concept, Hughes felt that the workload would be small enough for a one-man crew to effectively operate the F-15 aircraft. This conclusion was substantiated by a comparison of F-15, F-105, and F-106 weapon systems in which it was determined that the F-15, which combines the capabilities of both the single-man F-105 and F-106 aircraft, would be no more complex, and in many instances, simpler to operate than either of these systems.

In an anonymous Navy position paper (1973), the merits of a two-seat versus a single-seat aircraft for air-to-air combat and fleet air superiority are discussed. The paper extolls the virtues of the two-seat configuration as summarized in the following quotation:

The two-seat fighter offers significant advantages over single seat aircraft in both short range air-to-air combat over enemy territory and longer range fleet air superiority encounters. The air-combat advantages accrue primarily because the two-man crew can sight and acquire targets quickly while maintaining six o'clock surveillance and SAM lookout. Fleet air superiority advantages stem from the ability of the second crew member to concentrate attention on sophisticated multiple target threats and ECM while the pilot flies the aircraft and maintains the essential visual surveillance.

A two-man crew permits a double check on flight procedures and minimizes diversion of pilot attention from flying the aircraft. Dual seat aircraft consequently enjoy a 2 to 1 safety improvement over single seaters in Navy experience.

The high combat kill effectiveness of the two-man fighter in Navy missions combined with low losses due to accidents and enemy action make the second seat a good investment for Navy fighter aircraft.

Actual experience with two-place versions of several fighter aircraft seems to refute the argument of a large performance penalty. A good illustration is the F-106A/F-106B experience. To provide the additional seat, life-support equipment, dual avionics, and structure, the F-106B weighs 900 pounds more in the combat configuration than the F-106A. In this configuration it carries 200 pounds less fuel. Interestingly, because of its longer canopy and therefore better fineness ratio, the F-106B burns slightly less fuel and thus the fuel penalty at takeoff is cancelled during a typical 2 hour mission. Except for a 2 knot faster final approach speed, aerodynamic performance of the F-106B is not discernibly different from the F-106A. Actual tech order figures show a weight of 889 pounds more for the F-106B with 416 pounds less fuel. The two place F-15 weighs 800 pounds more than the single place version and carries the same amount of fuel. The two place F-16 will weigh approximately the same as the single-place but carry 600 pounds less fuel.

The issue of aircrew workload in tactical strike, attack, and reconnaissance missions was addressed by F. ter Braak (1974) in terms of physical, mental, psychological, and training factors. Comparing one- and two-man crews, F. ter Braak states that the physical and mental workload factors are not reduced with a two-man crew because each crewman performs his task under the same circumstances as a single pilot crew. In fact, the need for crew coordination is an added task that increases workload in a two-man aircraft. The psychological factor is also assumed to be equivalent for one- and two-man aircrews. In general, F. ter Braak does not believe there is an appreciable difference in workload between one- and two-man aircraft.

The five papers reviewed in the preceding pages reveal a wide range of opinions regarding the benefits of a two-man aircraft compared to a single-man aircraft. The Boeing study, which was the only man-in-the-loop simulation study, found target acquisition to be slightly faster (1 second) with the two-man crew. Autonetics and Hughes analyses support the contention that with proper design a single-seat F-15 will do the job; hence a second crewman is not required. The Navy paper advocates a two-seat aircraft because of the higher probability of detecting and countering target threats. The analysis of crew workload by F. ter Braak concludes that adding a second crewman would not reduce crew workload.

The question of a single pilot/radar operator's ability to both control aircraft systems and successfully recognize and designate radar targets in a limited time profile cannot be adequately answered from existing information. Therefore, it cannot, with little risk, be stated that a SAR should be used in single-seat aircraft.

Clearly, a pilot in a single-seat aircraft who is flying on autopilot in a low threat environment with all systems working properly can accomplish a SAR air-to-ground strike mission as well as a pilot and weapons system officer in a two-seat aircraft. The potential advantage of the second crewman would occur in high workload situations and high threat environments. No known research has quantitatively addressed the issues of workload, outside cockpit threat detection, and SAR target recognition for the air-to-ground strike mission with one- and two-man aircrews. The simulation study described in this report was therefore conceived to address these issues and provide information for the Air Force to determine if SAR systems should be placed in single-place aircraft.

SUMMARY

A Tactical Air Command, shallow interdiction, air-to-ground strike mission formed the structure for the simulation study. Both one- and two-man crews were evaluated during three phases of a 350-second mission that included ingress, penetration, and ground target acquisition. The ingress phase lasted 40 seconds and simulated the time required to reach the Forward Edge of the Battle Area. The penetration phase lasted 220 seconds and simulated the traversing of hostile territory to the assigned target area. The target acquisition phase simulated 90 seconds over the target area during which the crew recognized and designated the prebriefed ground target.

Two cockpit configurations were required to allow the assessment of both one- and two-man crew sizes. In the one-man crew simulation, all controls and displays were located in a single cockpit, while in the two-man crew simulation the controls and displays were divided between two cockpits. Regardless of configuration, however, the following controls and displays were functional:

Multi-mode CRT Display

Radar Warning Receiver (RWR) and Threat Bearing Indicator

Countermeasures Control Panel
Flight Stick
Throttle and Radar Acquisition Control
Hack Clock
Communications Controls.

The multi-mode display served as a Vertical Situation Display (VSD) during the ingress and penetration phases, while in the target acquisition phase it presented synthetic aperture radar ground map video and simple flight information. The Radar Warning Receiver and Threat Bearing Indicator alerted the crew to four types of threats and indicated the relative bearing of each. The countermeasures control panel provided a means for the operator to respond to threats. A standard flight stick was used by the pilot to control the pitch and roll attitude of the aircraft. A throttle provided control over the displayed airspeed of the aircraft and included the radar acquisition controls. A Hack clock and communications controls completed the complement of controls and displays.

The two cockpits were interfaced to a hybrid computer that performed the majority of the simulation including aerodynamic model, radar model, threat scenario logic, and symbolic display dynamics. A stroke symbol generator and an in-raster symbol generator produced the symbols for the vertical situation and ground map displays, respectively. A television camera and light box arrangement converted the SAR ground map film imagery to video form for display. Through appropriate interface equipment, the computer could determine the positions of all switches and controls in both cockpits and generate the required displays.

Surrounding both cockpits were 180-degree cylindrical screens on which small lights were mounted to simulate outside-cockpit threats. Illumination of the lights was under computer control and determined by the threat scenario. Crew responses could be detected by the computer which allowed automatic data collection.

A crew had a number of tasks they were required to perform during the mission. These included the following:

Flight control
Air-to-air radar monitoring and target lock-on

Radar warning receiver monitoring
Countermeasures activation
Outside-cockpit threat detection
Ground map radar target recognition and designation
Communications with Airborne Command and Control Center and second crewman.

One- and two-man crews, five threat densities (workload) from zero to an average of 14.1 threats per minute, and the three mission phases were examined using a mixed-factor factorial design and a latin-square counterbalancing of ground targets, subjects, and threat density levels. Subjects were Tactical Air Command Pilots and Weapon Systems Officers. A total of 20 crews participated - 10 single-man and 10 two-man. Flight control, threat detection and response, and ground map target acquisition performance were measured.

Crew size and threat density affected the crews' ability to control aircraft altitude and heading, as shown in Figures 1 and 2. At zero threat density, one- and two-man crews were equivalent. As threat density (workload) increased, flight control performance degraded. The performance degradation was much more rapid for one-man crews than for two-man crews. A larger degradation of altitude control performance compared to heading control with increased threat density was probably due to the greater importance of controlling heading to arrive at the ground map radar-turn-on point.

The four types of threats to which the crews were required to respond during the simulation were categorized into threats that required inside-cockpit visual tasks and outside-cockpit visual tasks. Figure 3 shows a comparison of in-cockpit and out-cockpit threat detection performance for one- and two-man crews at various threat densities during the SAR target acquisition mission phase. There was no appreciable difference between one- and two-man crews for inside-cockpit threats, except at the highest threat density where the one-man crews were better. The superiority of the one-man crews at the highest threat density was caused by a breakdown in two-man crew task coordination in the SAR target acquisition phase which

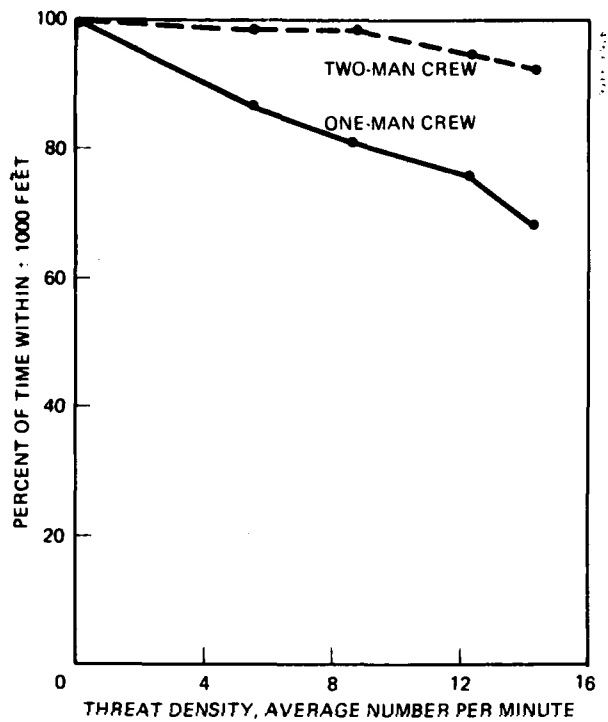
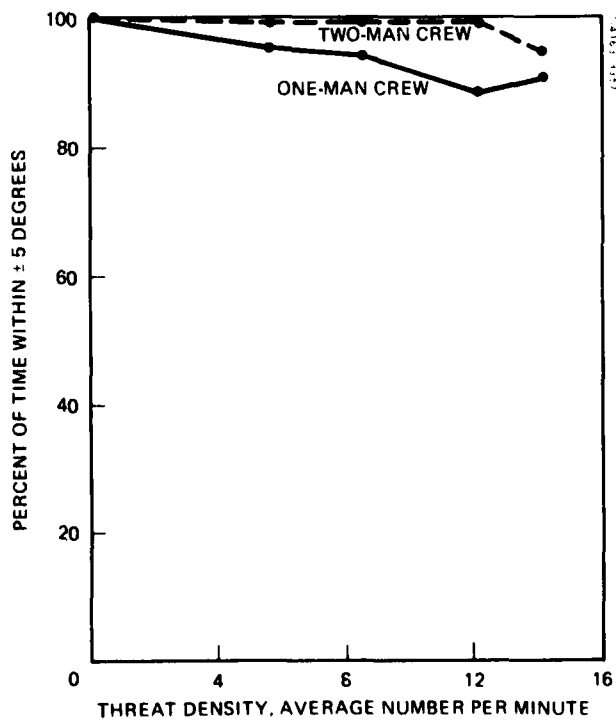
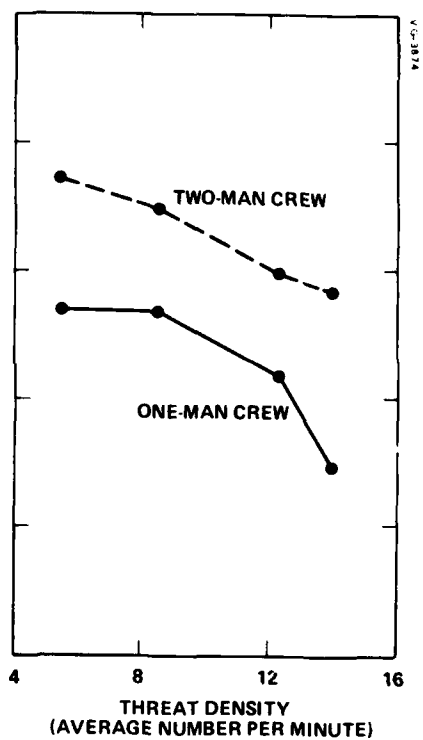
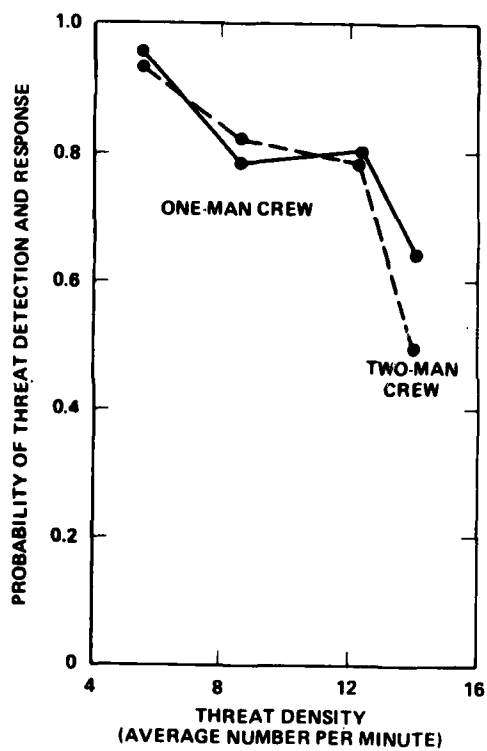

Figure 1. Effects of threat density and crew size on aircraft altitude control performance.

Figure 2. Effects of threat density and crew size on aircraft heading control performance.





a. Inside-cockpit threats

b. Outside-cockpit threats

Figure 3. Comparison of inside and outside cockpit threats for one- and two-man crews and threat densities in the SAR target acquisition mission phase.

caused inside-cockpit threat detection to degrade more for two-man crews than for one-man crews. In the penetration phase, the two-man crews were slightly superior to the one-crews at the highest threat density.

Two-man crews were significantly better than the one-man crews in outside-cockpit threat detection. Approximately 40 to 95 percent more outside-cockpit threats were detected by the two-man crews across the four threat densities. The second crewman was a decided advantage for outside-cockpit visual surveillance.

Crew size and threat density effects on SAR target acquisition time are shown in Figure 4. Less time was required by the two-man crews except at the highest threat density. The effects of crew size and threat density on probability of correct SAR target acquisition are shown in Figure 5. The two-man crews again were superior to the one-man crews except at the highest threat density.

The probable reason for the superior performance of one-man crews at the highest threat density is the ignoring of outside-cockpit threats until the SAR target acquisition task was completed. Though one-man crews performed better than two-man crews at the highest threat density, they sacrificed outside-cockpit threat detection to do so.

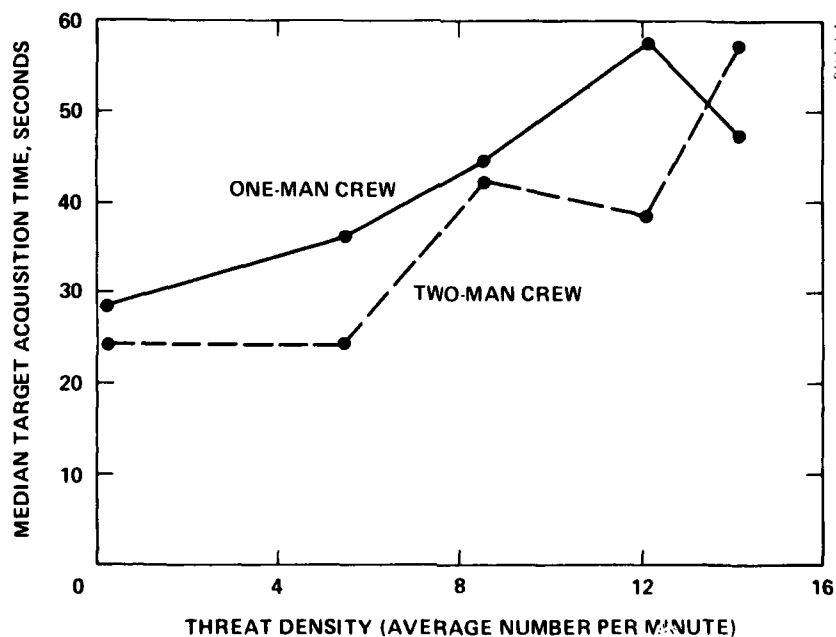

Figure 4. Crew size and threat density effects on time to acquire SAR targets.

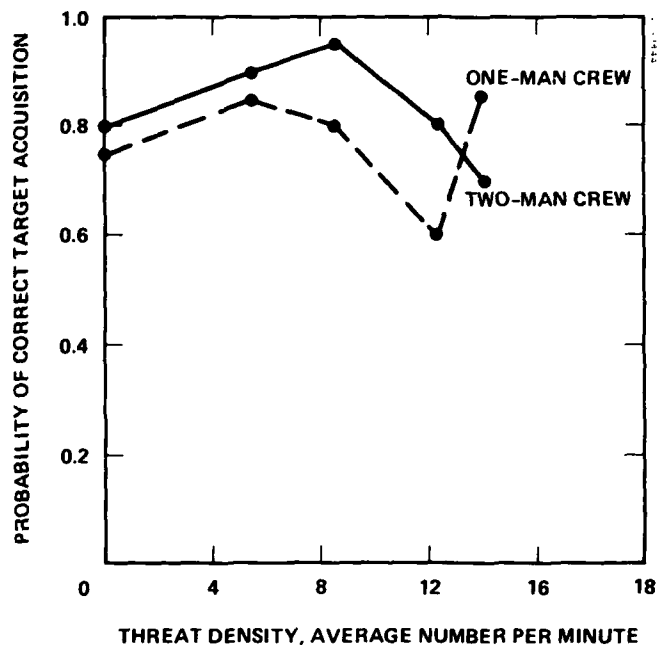

Figure 5. Crew size, threat density, and probability of target acquisition.

In general, two-man crews were superior to one-man crews at aircraft flight control, outside-cockpit threat detection, and SAR target acquisition tasks. The dominant superiority of two-man crews, however, was for outside-cockpit threat detection. A major advantage for a two-place SAR air-to-ground strike aircraft, therefore, is the improved visual surveillance achieved with two crewmen and the resulting increased survivability when over hostile enemy territory.

SECTION 2

SIMULATION METHODOLOGY

MISSION PROFILES

The Tactical Air Command (TAC) shallow interdiction mission shown in Figure 6 provided the structure for the simulation. The simulated aircraft performed the strike function, and an imaginary second aircraft acted as wingman. The mission was functionally divided into four phases: pre-mission loiter, ingress, penetration, and target acquisition. Data were collected during the last three of these phases. The total mission length was 350 seconds.

During the pre-mission phase, the simulated aircraft loitered at 10,000 feet altitude and 300 knots awaiting strike orders from the Airborne Command and Control Center (ABCCC). At the beginning of a simulation trial, the ABCCC transmitted verbal descriptions of the target type, target location, and target aimpoint as well as target area geographical features of potential use in recognizing the ground target. When the crew acknowledged the targeting information, the ABCCC directed the strike aircraft to a specific altitude, airspeed, and course to intersect the ground map radar turn on point (RTOP).

The ingress phase began when the aircraft departed the loiter area on a heading to the target area. It continued for 40 seconds and simulated the time required to reach the Forward Edge of the Battle Area (FEBA). During this time the crew established the correct altitude, heading, and airspeed as directed by the ABCCC. As the aircraft were over friendly territory during this phase, no threat indications were received.

The penetration phase followed the ingress phase and simulated the traversing of hostile territory to the assigned target area. This phase lasted for 245 seconds during which the crew was required to detect and respond to threat indications as well as perform communications, flight control, and navigation functions.

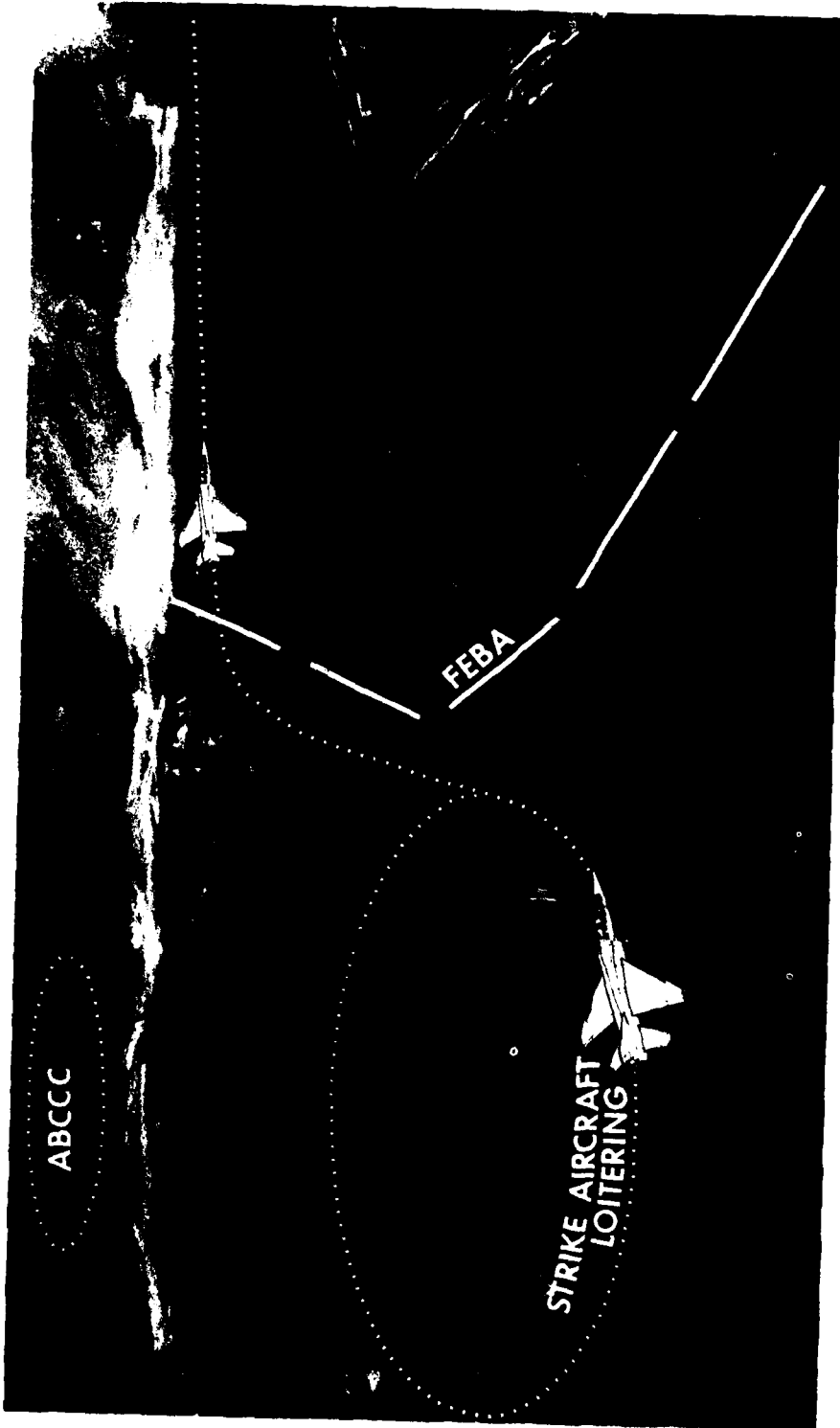

Figure 6. Shallow interdiction mission profile.

The final phase was the SAR target acquisition portion of the mission. This phase lasted for 90 seconds and began at the RTOP when the radar automatically switched to the ground map mode of operation. The crew was required to recognize and designate the prebriefed target and to detect and respond to threat indications. Flight control was not required, however, as the autopilot system was activated during this phase.

Both one- and two-man crews were evaluated in the simulation. The number of threat indications during the penetration and target acquisition phases were varied from none to a total of 74 threats (zero to an average of 14.1 threats per minute). These threats were of several types as will be detailed later.

COCKPIT CONFIGURATIONS

Because both one- and two-man crews were to be evaluated, the simulation equipment needed two cockpit configurations. In the one-man simulation, all controls and displays were located in a single cockpit so that a single operator could perform all mission functions. In the two-man simulation, the required tasks were divided between the operators, and the two cockpits reflected this division by the controls and displays used in each of the cockpits.

One-man Cockpit

The single-seat cockpit configuration is shown in Figure 7. The major displays and controls in this cockpit are:

- Multi-mode Display
- Radar Warning Receiver (RWR) and Threat Bearing Indicator
- Countermeasures Control Panel
- Flight Stick
- Throttle and Radar Acquisition Control
- Hack Clock
- Communications Controls.

The following paragraphs detail the operation of each of these components.

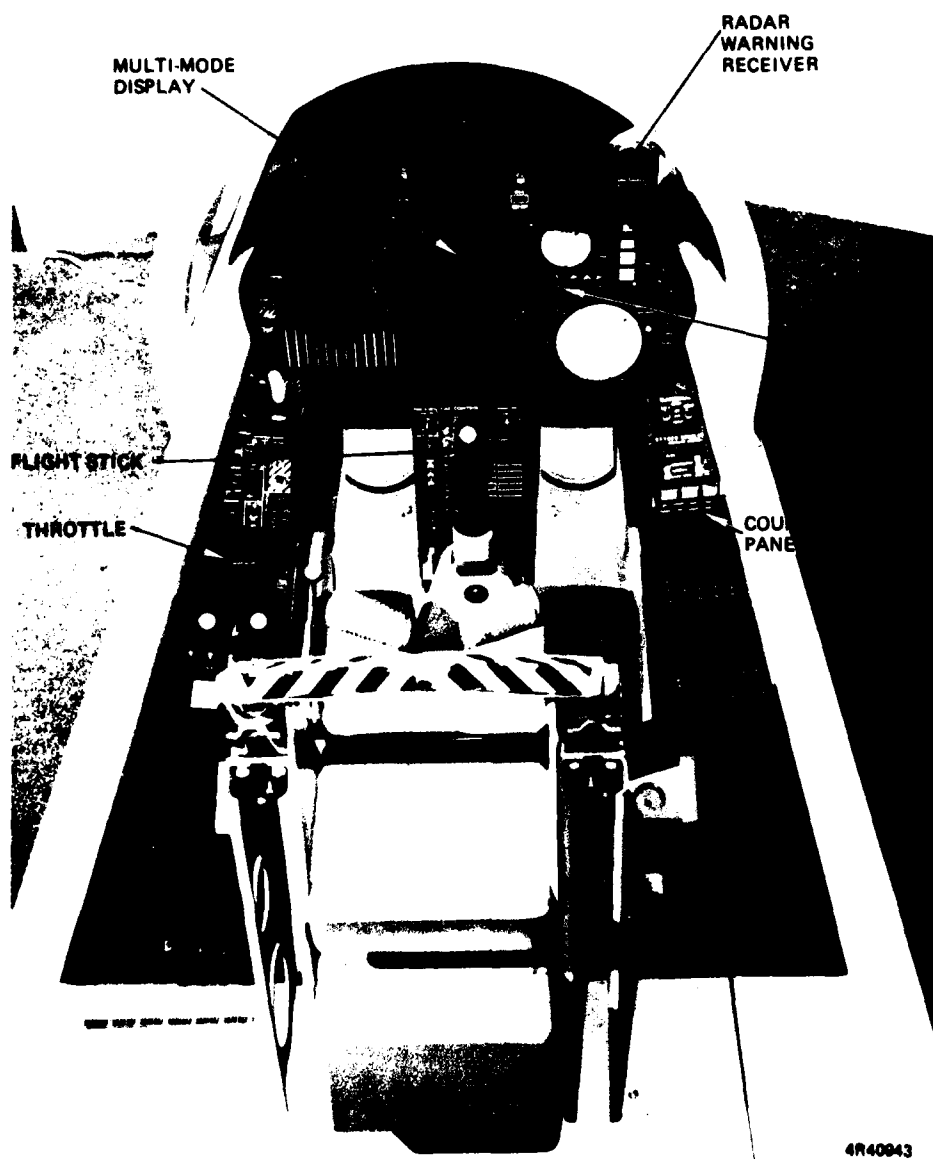

Figure 7. Single-seat cockpit configuration.

Multi-mode display. The multi-mode display provided the primary means of communicating dynamic information to the crew. In the ingress and penetration phases of the mission, it served as a Vertical Situation Display (VSD) while in the target acquisition phase it presented ground map radar and simple flight information.

Figure 8 shows the flight and navigation symbology displayed prior to the RTOP. The vertical scale on the left presented aircraft airspeed in knots, and the right-hand scale presented altitude in thousands of feet. Both of these scales were fixed with a moving indicator. A moving scale, fixed-pointer presentation of heading was presented across the top of the display. A fixed lubberline in the center of the display represented one's own-ship, while a moving horizon line presented attitude information.

The two digital readouts labeled RNG and BRG presented range, in nautical miles, and relative bearing in degrees, to the RTOP. The bearing

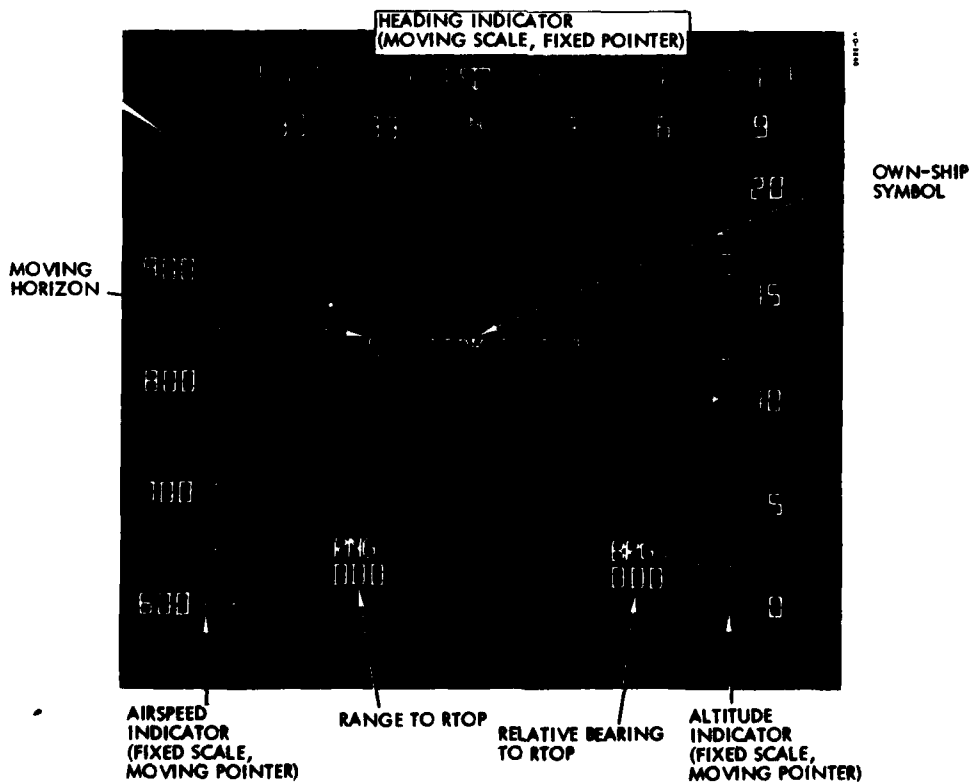

Figure 8. Flight and navigation symbology on multi-mode display.

indication functioned in the same way as an Automatic Direction Finder (ADF). These two readouts provided the necessary information for the pilot to navigate a specific track to the RTOP.

In addition to flight and navigation symbology, the multi-mode display also presented air-to-air radar data. Figure 9 is similar to Figure 8 with air-to-air radar search symbology added. The vertical line represented the azimuth angle of the radar with the edge of the display representing the ± 90 degree limits of the radar scan pattern. The small tick mark near the airspeed scale indicated which of the four 5-degree elevation bars was currently being scanned by the antenna. A cursor, consisting of a pair of short vertical lines, could be controlled by the operator to designate air-to-air targets. Figure 9 also shows the return from two air-to-air targets. These were presented in a B-scan, azimuth versus range, format with targets appearing as a trail of returns. This latter characteristic resulted from the simulation of a digitally scan-converted radar display which presented 16 seconds of target history. Thus, not only was the most recent return displayed

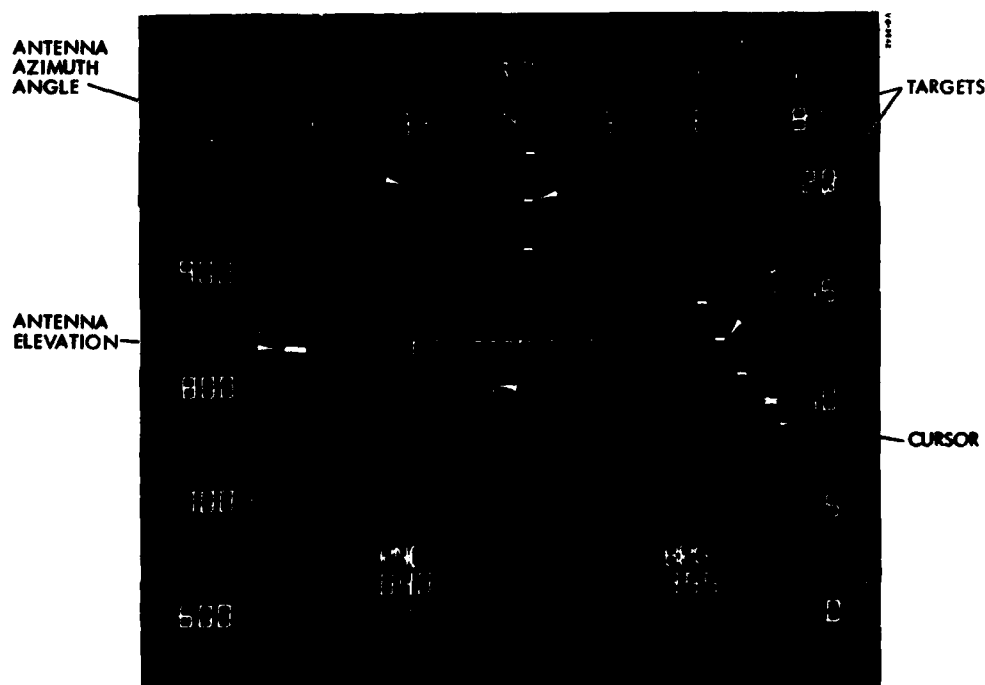

Figure 9. Air-to-air radar search symbology on multi-mode display.

but two or three previous returns as well. The range of the radar could be selected; however, in the present study it was held constant at 40 nautical miles.

Figure 10 depicts the multi-mode display with the air-to-air radar locked-on to a target. In this condition the azimuth angle indicator and all target returns were removed from the display and were replaced by two horizontal lines representing minimum and maximum missile launch ranges. In this lock-on mode the cursor represented the range of the target, and if it was within range, a missile could be launched.

At the RTOP, the radar was automatically switched to the ground mapping mode and the multi-mode display appeared as shown in Figure 11. Attitude information was presented superimposed on the synthetic aperture radar (SAR) imagery. Pitch and roll were shown by artificial horizon and pitch ladder symbols. A controllable diamond shaped cursor was also displayed.

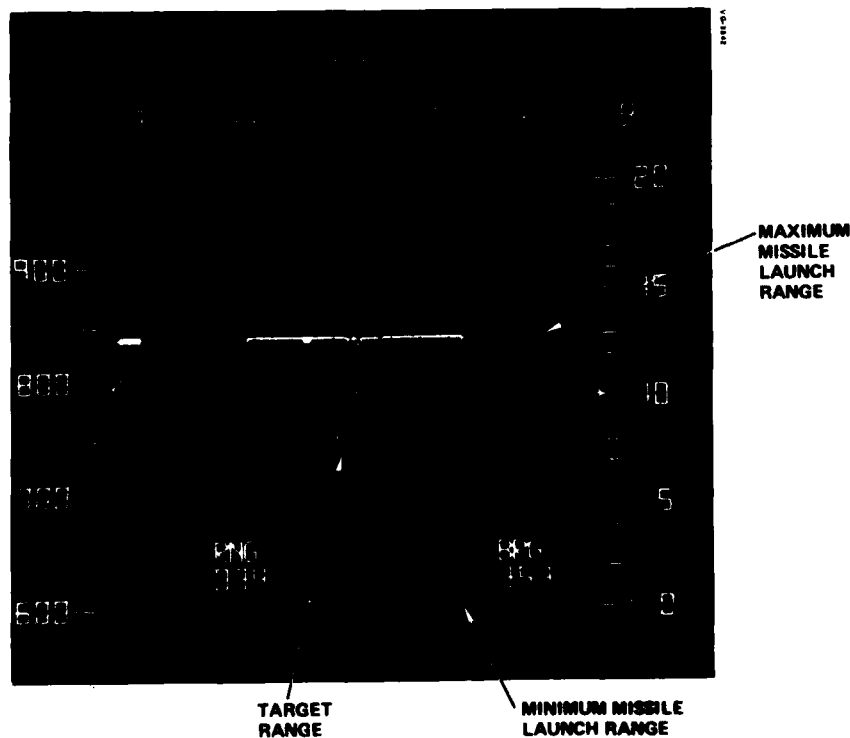
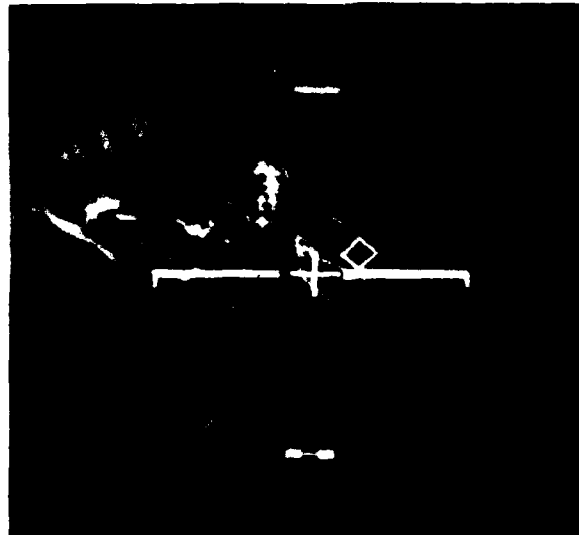

Figure 10. Air-to-air radar lock-on symbology on multi-mode display.



VC-3043

Figure 11. Radar video and symbology on multi-mode display.

Radar Warning Receiver and Threat Bearing Indicator. Figure 12 details the radar warning receiver (RWR) panel and the associated threat bearing indicator. This panel alerted the crew to impending and actual threats. The four indicators on the right of the panel identified the type of threat as SAM (Launch), SAM (Tracking), AAA, or AI. In addition to the illumination of an indicator light, an aural tone also sounded in the operator's headset. A low frequency tone indicated a SAM (Launch) while a high frequency tone indicated one of the other three threat types. For each threat indicated by a threat type light, a small light was also illuminated in one of the 12 possible clock positions around the circular threat bearing indicator shown on the left in Figure 12. These small lights simulated the strobe line indication typical of actual RWR systems and provided the operator with the relative bearing of the threat.

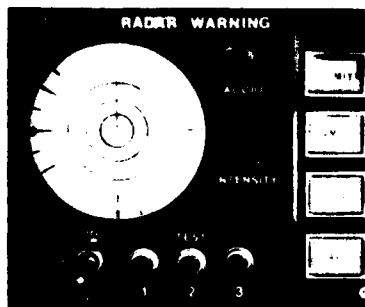

Figure 12. Radar warning receiver and threat bearing indicator.

against a target beyond its range, the target would remain and the radar would continue in the lock-on mode. If the target was in range, then after a delay simulating the flight of the missile the target would be removed, and the radar would return to the search mode.

The length of time a particular threat type indication remained active depended on the operator's response and the mission scenario. In the absence of any response or an incorrect response from the operator, the scenario would call for a threat to remain active for a randomly determined time between 15 and 20 seconds. If the operator made a correct response, the threat type light and the associated tone would extinguish 3 seconds later.

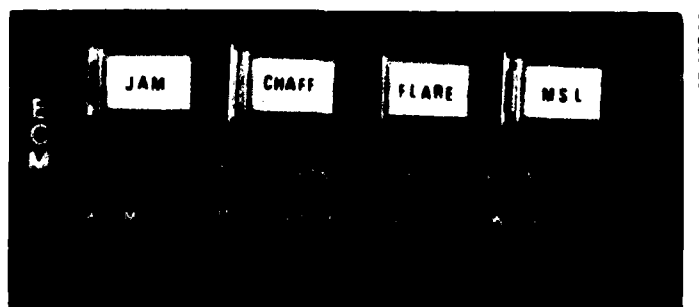

Figure 13. Countermeasures control panel.

Flight Stick. A standard flight stick was used by the pilot to control the pitch and roll attitude of the aircraft. No trim control was provided.

Throttle and Radar Acquisition Controls. A throttle was located on the left-hand side console and provided control over the displayed airspeed of the aircraft. Because it was necessary for the threat density (threats per unit of time) to remain constant for any given threat level, the time of each mission phase needed to remain fixed. This was accomplished by always keeping the ground speed and the distances to the FEBA and RTOP constant. The pilot could adjust the displayed airspeed which he believed also changed the ground speed.

The radar acquisition controls were mounted on the throttle. These consisted of a combination force control and acquisition switch, and a break-lock switch. The force control was mounted such that it was easily activated with the second finger of the left hand while gripping the throttle. The force control action positioned the cursor on the display by controlling the rate and direction of cursor movement.

When the cursor was positioned according to the operator's desires, he could squeeze and release the force control to command the radar to the acquisition mode. In this mode the radar antenna rapidly scanned all four elevation bars and a 10-degree azimuth area centered around the cursor position. If a target return was received within the area defined by the cursor, the radar transitioned to the lock-on mode. If no return was received, or one was not within the cursor gate, the radar returned to the search mode after 5 seconds.

The break-lock switch was located on the throttle under the first finger. If the radar was locked onto a target, actuation of this switch caused the radar to return to the search mode.

Hack Clock. A hack clock was available for the crew to use in whatever manner they chose.

Communications Controls. Controls were provided to allow the crew to adjust the audio gain to the head-set. Also provided was a mute switch that automatically reduced the audio gain to a low level. The communications channel included a link to the ABCCC, typical wide area background communications activity and, in the two-man case, intercom.

Two-man Cockpit

In the two-man configuration, a second cockpit was added to the simulation to accommodate the Weapons System Officer (WSO). Both cockpits are shown in Figure 14. The controls and displays in the front cockpit remained the same as in the one-man case with two exceptions. The Radar Warning Receiver and Threat Bearing Indicator were removed and the radar controls were deactivated.

The rear-cockpit was equipped with a Multi-mode Display, Radar Warning Receiver and Threat Bearing Indicator, Hack Clock, and Communications controls that functioned in the same manner as in the *single-seat* configuration. The radar cursor control, lock-on, and break-lock functions in the rear-seat were accomplished using the center-mounted hand control and associated switches. The rear-seat cursor control was a first-order or position control rather than a rate control as in the front cockpit. Lock-on in the rear-seat was accomplished using the hand control mounted trigger switch and break-lock was activated by the top thumb switch on the control.

SIMULATION EQUIPMENT

The two cockpits were interfaced to a hybrid computer and other equipment as shown in block diagram form in Figure 15. A Xerox Data Systems 9300 digital computer and an Applied Dynamics AD-4 analog computer formed a hybrid computer system that performed the majority of the simulation, including aerodynamic model, radar model, threat scenario logic, and symbolic display dynamics. A stroke symbol generator and an in-raster symbol generator produced the symbols for the vertical situation and ground map displays, respectively. A television camera and light box

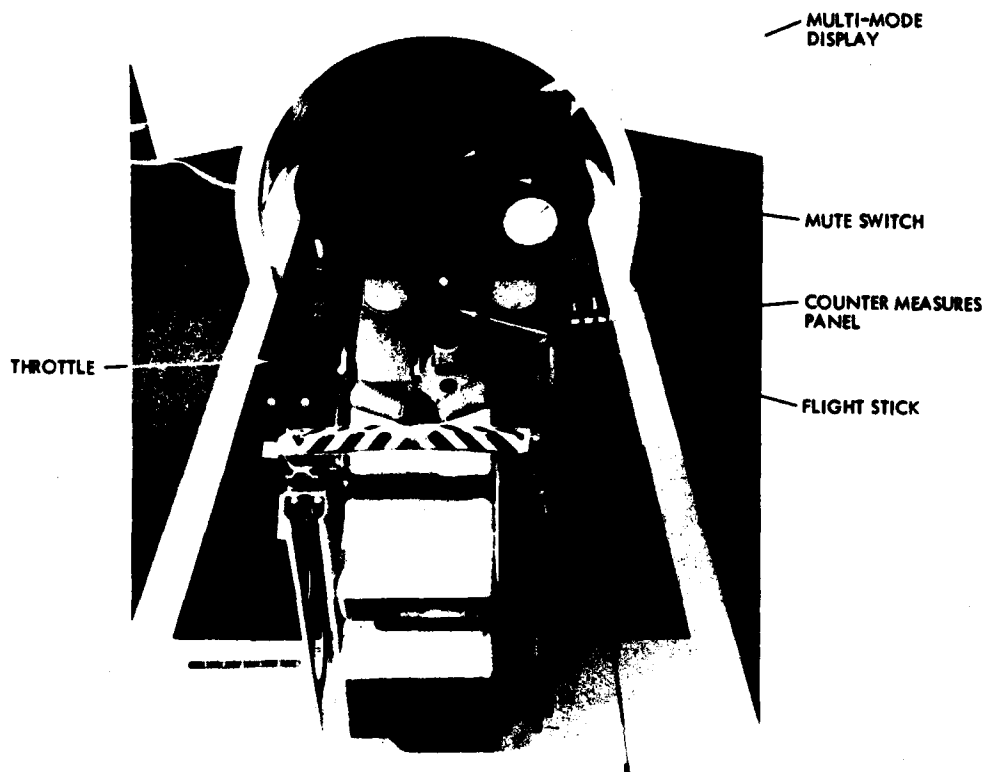

a. Front cockpit

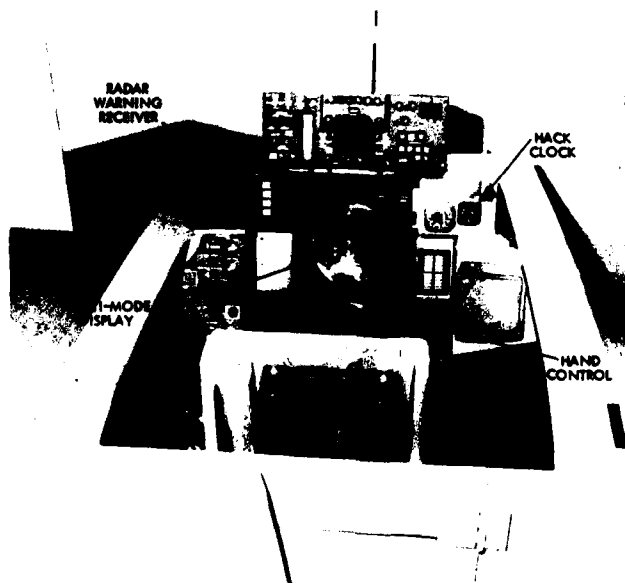

b. Rear cockpit

Figure 14. Cockpits used for the two-man cockpit configuration.

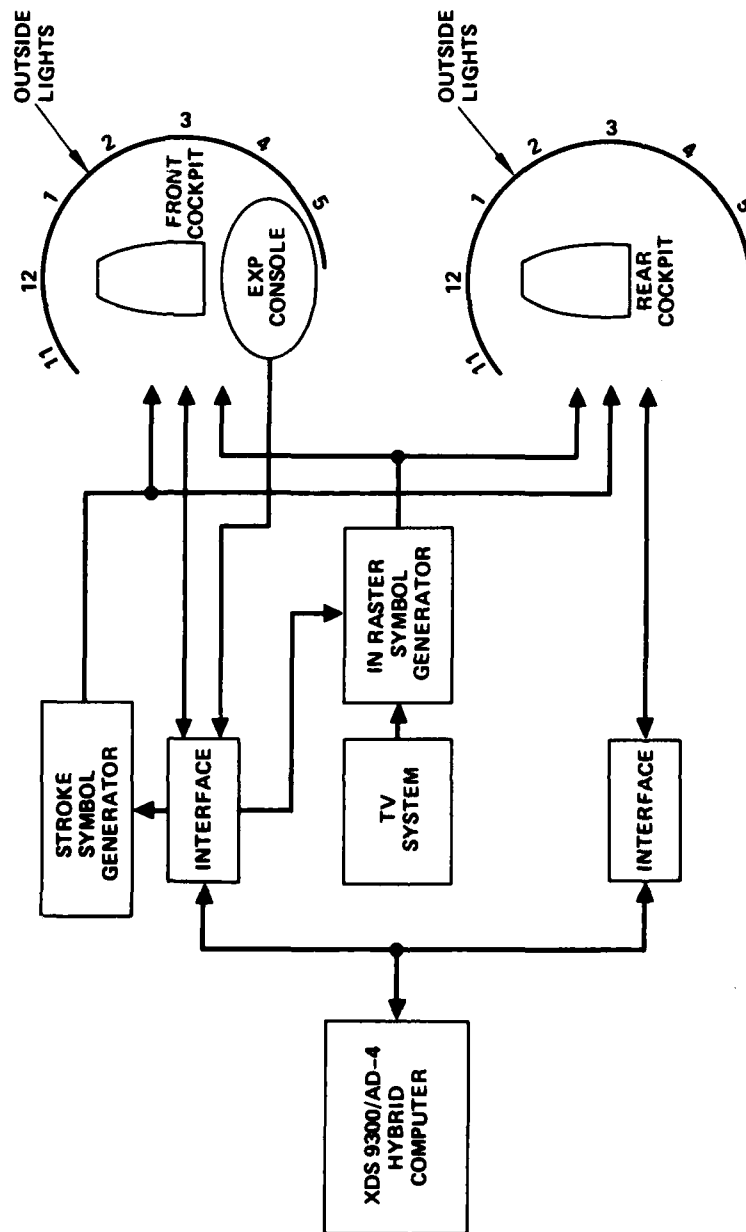

Figure 15. Simulation equipment block diagram.

arrangement converted the radar group map film imagery to video form for display. Through appropriate interface equipment, the computer could determine the positions of all switches and controls in both cockpits and generate the required displays.

Surrounding both cockpits were 180-degree cylindrical screens on which small lights were mounted. These screens extended from the 11 o'clock to the 5 o'clock positions with a high, low, and level light at each position. The 21 lights served to simulate outside cockpit threats. Illumination of the lights was under computer control and determined by the threat scenario. The screen and a few of the lights can be seen in Figure 16. Clock positions 6 to 10 were not simulated as they were the responsibility of the imaginary wingman as indicated in Figure 16.

All crew responses could be detected by the computer except the detection of the outside threats. The operator's response to these was a verbal call-out. To get this information into the computer so it could be recorded along with other responses required that an experimenter press a button indicating the clock position called out. These buttons were located on a small panel behind the front cockpit. This panel can be seen in Figure 16.

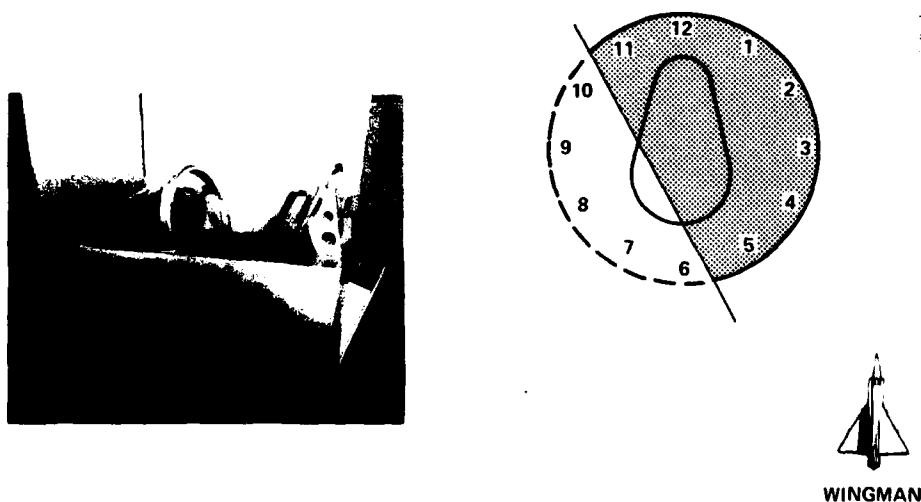

Figure 16. Outside-cockpit threat set-up.

The simulation software was designed to allow the maximum flexibility in threat scenario definition. This was accomplished by having the computer read a set of scenario definition cards at the beginning of each simulation run. These cards specified a time into the mission at which a particular threat was to be activated or deactivated. The possible threats were air-to-air radar, RWR, and outside cockpit lights.

For the air-to-air radar threats, a total of 16 possible targets, each with a different heading and speed, could be selected. At any given time a maximum of four air-to-air radar targets could be active.

Four possible RWR threat types could be specified: SAM (Tracking), SAM (Launch), AAA, and AI. The bearing of the threat and whether an outside light should be associated with RWR threats was specified for each RWR threat. An outside light was illuminated for all RWR threats between 11 and 5 o'clock unless the threat type was a SAM (Tracking). A specification of High, Level, or Low was also input for the outside light. Outside lights could be activated and deactivated in association with a RWR threat or independently as non-RWR threats.

Data collection was performed automatically by the computer. All pertinent information about the simulation and the operator's responses were stored 20 times a second. When a full second of data had accumulated, it was written onto magnetic tape. This tape was later used by another program to assess performance.

OPERATOR TASKS

The crew had a number of tasks they were required to perform during the mission. These included the following:

- Flight control
- Air-to-air radar monitoring and target lock-on
- Radar warning receiver monitoring
- Countermeasures activation
- Outside-cockpit threat detection
- Ground map radar target designation
- Communications with ABCCC and second crewman.

The flight control task required the operator to maintain an assigned altitude, heading, and airspeed. To make the task slightly more demanding, no trim was available and the aircraft had a tendency to roll in one direction or the other. The air-to-air radar task required the crew to detect air-to-air targets, coordinate with ABCCC concerning their status as hostiles or friendlies, acquire and lock-on to hostiles, and fire a missile when in range. The procedures for accomplishing these tasks have been described previously.

A majority of the threats appeared as indications on the radar warning receiver display panel and associated threat bearing indicator. As described earlier, four threat types could be displayed. These were SAM (Launch), SAM (Tracking), AAA, and AI. The crew was cued to one of these threats by an audio tone in their headset in addition to the presence of the threat type indication. The operator's task was to detect the threat and its type then examine the threat bearing indicator to determine the clock position of the threat. In situations where many threats were present, this required the operator to remember which threat bearing lights had already been illuminated. The operator then verbalized the threat in the following format "Sam launch at 3 o'clock". Along with this verbalization, the crew member cancelled the threat by activating the appropriate countermeasure. The correct responses were:

<u>Threat Type</u>	<u>Countermeasure</u>
SAM (Launch)	JAM
SAM (Tracking)	JAM
AAA	CHAFF
AI	FLARE.

A slight modification to the RWR threat procedure given above occurred in the two-man case because of the particular cockpit configuration. The rear-seat had the RWR display panel but the front seat had the countermeasures control panel. Because of this, the WSO was required to ask the pilot for the desired countermeasure. Both crew members heard the audio tone.

If the threat type was any other than a SAM (Tracking) and it's bearing indication was between 11 and 5 o'clock, the operator examined the outside lights at the appropriate bearing to discern whether it was high, level, or low. When he found the position he called out in the following manner: "three o'clock light on." If the threat type was a SAM (Tracking) no outside light was illuminated. Similarly, if the threat was between 6 and 10 o'clock, it was the responsibility of his imaginary wingman and no outside light appeared.

Not all outside lights were cued by RWR indications. Non-RWR outside lights could also occur at any time which required the crew to scan outside the cockpit for any new lights that had come on. The response was the same as for RWR outside lights and required a call-out of bearing and altitude (high, level, or low). The operators were also asked to call any lights that had extinguished; although these data were not analyzed.

One nautical mile prior to the RTOP the aircraft was placed in auto-pilot to remove the flight task requirement during SAR target acquisition. At the RTOP, the radar automatically switched to the ground map mode and the crew searched for the target. The target was prebriefed and its coordinates known, thus the operator correlated the displayed video with his map to detect the target. Acquisition was accomplished by moving a cursor over the target and activating the lock-on switch. If the first designation was deemed by the crew member to be incorrect, activation of the break-lock switch allowed redesignation. The radar controls were the same as for the air-to-air mode.

The final task required of the crew was communication with the ABCCC. This consisted of receiving ground target information, air-to-air target IFF data, and navigation information if the aircraft strayed too far from course. In the two-man configuration, additional communication was required of the crew members to coordinate their efforts.

RESEARCH DESIGN

A mixed-factor factorial design was used to assess the effects of crew-size, threat density, and mission phase. Because each subject was required to be in only one crew size, this variable was between-subjects. All threat densities and mission phases were seen by every subject; hence, these were

within-subject variables. A latin-square technique was used to counter-balance ground targets, subjects, and threat density levels. This counter-balancing reduced the effect of any transfer resulting from one condition preceding or following another.

Variable Levels

Two crew sizes, five threat densities, and three mission phases were examined. Across the five threat densities, the total number of threats varied from 0 to 74. The exact distributions of these threats by type and mission phase are detailed in Figure 17.

Subjects

Subjects were Tactical Air Command Pilots and Weapon Systems Officers. A total of 20 crews participated, 10 single-man and 10 two-man. In the case of two-man crews both members had previously worked together as crews in F-111, F-105G, RF-4C, or F-4 aircraft. One-man crews were pilots of A-7 or F-104 aircraft. All the crews were composed of highly skilled instructors with combat experience.

Threat Level	Mission Phase															Total	Average Number per Minute					
	Ingress						Penetration					Target Acquisition										
	Threat Type						Threat Type					Threat Type										
	SAM (L)	SAM (T)	AAA	AI	NON-RWR	A/A	SAM (L)	SAM (T)	AAA	AI	NON-RWR	A/A	SAM (L)	SAM (T)	AAA			AI	NON-RWR	A/A		
1	None						0	0	0	0	0	0	0	0	0	0	0	0	0	0	0	0
2	None						1	1	4	6	4	3	2	2	2	2	1	0	28	5.5		
3	None						6	2	9	7	8	4	0	6	1	0	3	0	46	8.6		
4	None						3	5	10	13	12	8	4	1	4	2	0	0	62	12.2		
5	None						6	5	6	17	15	10	3	1	7	2	2	0	74	14.1		

Figure 17. Threat densities and distributions.

Performance Measures

The performance measures fall into three major categories — flight control, threat detection and response, and SAR ground map target acquisition. However, because of the distribution of tasks across mission phases, not all measures were available in every phase. For example, ground target acquisition occurred only during the last phase of the mission.

Aircraft flight control was measured as percent of the time the altitude and heading were within a specified tolerance. The tolerance for altitude was ± 1000 feet and for heading it was ± 5 degrees. Flight control performance was not measured during the target acquisition phase because the autopilot was engaged.

Threat detection was measured as the probability of correct response. Probabilities were calculated for RWR inside-cockpit responses, RWR outside lights, non-RWR outside lights, and air-to-air radar targets. No threats occurred during the ingress phase, so these probabilities were calculated for the last two phases only. For SAR ground target acquisition the probability of correct target acquisition and the time required for acquisition were measured.

PROCEDURES

In the simulation study, each crew received a total of ten test and five training trials. The training and test trials were given in three, two-hour blocks over a one-and-a-half day period. Prior to beginning the training trials, each crew received a 90-minute briefing which described in detail the purpose and objectives of the study program. This briefing included a demonstration of the cockpit simulators where each crew member received practice trials flying the simulator and working the displays and controls.

The 90-minute briefing followed the outline below:

- Program introduction which covered the current SAR state of the art
- The program approach which discussed the application of SAR to the TAC mission and in particular the shallow interdiction mission
- A walkthrough demonstration of the cockpit simulator discussing the various elements of the simulator that would be active in the simulation

- A detailed discussion of the displays and controls
- The simulation mission objectives in terms of the navigation/penetration task and various threat defenses that would be encountered
- A discussion of the various threats
- Threat responses required by the crew to negate a particular threat
- Crew task responsibilities for two-man crews
- A review of high resolution SAR imagery
- A discussion of the target recognition/designation task in the SAR ground map mode.

A standardized set of written instructions summarizing air-to-air, RWR and Non-RWR threats and the appropriate countermeasures were read by each crew member. These instructions were as follows:

Air-to-Air Radar

General

- Display shows radar hits on A/A targets
- Targets can be enemy or friendly
- ABCCC will sometimes give target location and IFF data

Operator Responses

- In two-man cockpit either operator can detect targets; however, only rear-seat operator can designate A/A targets.
- If target is a threat to you (based on range and intercept angle), place cursor over radar return and depress and release cursor control (puts radar in super search mode), lock-on to target and launch air-to-air missile ("Missile" pushbutton on countermeasures panel). Missile flight time averages 6 seconds.
- In two-man cockpit, pilot fires missile on command from WSO.
- Range of air-to-air missiles is 20 miles.
- Don't use missiles unless deemed necessary.

RWR Threats

General

Four types of threats:

SAM (tracking)
SAM (launch)
AAA
AI

- Aural tone occurs with RWR threats.
- SAM track, AAA and AI have same tone.
- SAM launch has different tone.
- Bearing indicators light up for all RWR targets.
- Lights between 11:00 and 5:00 positions are your responsibility.
- Lights between 6:00 and 10:00 positions are wingman's responsibility.
- Outside lights, 11:00 to 5:00 at high, level and low positions, light up for all SAM launch, AAA, and AI threats.

Operator Responses

- For any RWR threat, regardless of its position: 1) activate appropriate countermeasure:

SAM track - Jam
SAM launch - Jam
AAA - Chaff
AI - Flares

and 2) call out threat type and bearing.

- For all RWR threats between 11:00 and 5:00, search for outside light. When outside light is detected, call out position, i.e., bearing (11:00 to 5:00) and altitude (high, level, or low).
- Outside lights will be illuminated for 15 to 25 seconds. When light extinguishes call out bearing and altitude of the extinguished light (e.g., "2 o'clock low light out").

In the two-man crew condition, the RWR threat type display and bearing indicator were active in the rear-seat. The countermeasure panel was active in the front seat. Therefore, for a particular RWR threat, the WSO was required to identify the threat type and relative bearing and request the appropriate ECM action to be made by the pilot.

Non-RWR Threats

General

- Non-RWR threats are outside lights (between 11:00 and 5:00 at high, level, and low positions).
- No aural or threat type indication will occur to warn you of the occurrence of a non-RWR threat. Thus, you must periodically scan the outside lights to detect non-RWR threats.

Operator Responses

- When you detect a non-RWR threat, call out its position (bearing and altitude) e. g., "Light at 4 o'clock low."
- Non-RWR threats will be illuminated for 15 to 25 seconds.
- When the light extinguishes, call out bearing and altitude of the extinguished light (e. g., 4 o'clock low light out).

Upon completion of the verbal briefing, each crew received a 15-minute familiarization session in the cockpit simulator. This session was intended to familiarize the crew with the operation of the various displays and controls. The test conductor requested that specific heading, altitude, and airspeed be maintained. During this practice flight, several air-to-air targets were introduced which allowed the appropriate crew member (front seat in the single-seat, and rear-seat operator in two-seat configuration) to practice target lock-on and missile fire. Each crew flew two short missions where the only tasks involved were flying the aircraft and working the air-to-air radar.

At this time the crew returned to the briefing where any questions were answered. The test conductor spent approximately 5 minutes reviewing

procedures. The crews were assigned the call sign "RINGO" and were reminded to coordinate all air-to-air missile firing with the ABCCC "Allen Control".

Following the final briefing, one crew began the first training mission in the simulator. Prior to each trial the crew checked the status of all important displays and controls using a checklist provided. These lists are reproduced below.

Single-Seat Aircraft, Cockpit Initialization Checklist

Vertical Situation Display

Power - On
Symbol Brightness - Adjust for Comfort
Video Brightness - Set to Mid-Range
Video Contrast - Set to Mid-Range

Radar System

Power - Operate
Mode - A/A
Elevation Bars - 4
Azimuth Scan - $\pm 90^\circ$
Range - 40 NM
Store Time - 16 seconds

Throttle

Position - Set to Loiter Speed (300 knots)
Autopilot - Off

Communications System

Headset - On and Working
Volume - Adjust as desired
Mute - Off

RWR Display

Threat Type Plaques - Off
Bearing Lights - Off

Hack Clock

Wound
Reset

Targeting Package

1:50, 000 Scale Chart

Two-Seat Aircraft, Cockpit Initialization Checklist

Radar Display

Front Seat

Power - On
Symbol Brightness - Adjust for Comfort
Video Brightness - Set to Mid-Range
Video Contrast - Set to Mid-Range

Rear Seat

Mode - Operate
Video Brightness - Adjust to Comfort
Video Contrast - Set to Mid-Range

Radar System

Front Seat

Power - Operate
Mode - A/A
Elevation Bars - 4
Azimuth Scan - $\pm 90^{\circ}$
Range - 40 NM
Store Time - 16 seconds

Rear Seat

Mode - Operate
Elevation Bars - 4
Azimuth Scan - $\pm 90^{\circ}$
Range - 40 NM

Throttle

Front Seat

Position – Set to Loiter Speed (300 knots)
Autopilot – Off

Rear Seat

Cursor Control Mode – TID Cursor

Communications System

Front Seat

Headset – On and Working
Volume – Adjust as Desired
Mute – Off

Rear Seat

Headset – On and Working
Volume – Adjust as Desired
Mute – Off

RWR Display

Front Seat

Threat Type Plaques – Off
Bearing Lights – Off

Rear Seat

Threat Type Plaques – Off
Bearing Lights – Off

Hack Clock

Front Seat

Wound
Reset

Rear Seat

Wound
Reset

Targeting Package

Front Seat

1:50, 000 Scale Chart

Rear Seat

1:50, 000 Scale Chart

The five training trials were given in order of increasing workload. For the one-man crews, the pilot/WSO was handed a map chip (1:50, 000 AMS topographic chart) annotated with an "X" inside a scribed 1.5 by 1.5 nautical mile box. The "X" indicated where the target was or had been located, while the box indicated the amount of ground that would be covered by the radar but not necessarily the exact coverage that would be displayed. The operator was allowed to study the chart for approximately 20 seconds during which time he familiarized himself with the terrain and any contextual cues in the area. At this time "ALLEN Control" contacted "RINGO" flight as follows.

"Ringo flight, this is ALLEN control, I have a target, request an immediate strike. Target is a convoy of 10 tanks moving south-southwest at coordinates PV155830. Target is 1000 meters west of the town of HULLEN approaching bridge at PV153820. Strike lead vehicle. Do you copy?" "Roger ALLEN" (RINGO reads back target data). The operators then spent an additional 20 to 30 seconds studying the map chip and making annotations as required. "ALLEN Control" then directed the crew to fly a particular altitude, heading, and airspeed to intercept the desired radar-turn-on point (RTOP). After the crew had acknowledged the flight profile data, the mission began. The crew's tasks were to fly the aircraft, monitor the air-to-air radar, monitor RWR threats, take countermeasure action, monitor outside RWR and non-RWR threats, and perform target recognition and designation on a high resolution SAR ground map.

As previously discussed, the training trials were given in order of increasing workload level (threat density). As each training trial was completed, a short critique was given by the test conductor. The critique was given primarily to reinforce consistent responses among crews. Each crew was given a 5 to 7 minute break between training trials.

Following the five training trials, the ten test trials were given. The procedures for the test trials were identical to the training trials except that the crews were not told which threat density to expect.

GROUND MAP RADAR IMAGERY

High resolution synthetic aperture radar imagery was used in the simulation. The radar imagery used was recorded during a military exercise conducted in 1974. The radar imagery was of excellent quality and sampled a variety of tactical targets in typical scenarios. The radar had a displayed resolution of 20 feet and a 1.5 nautical mile square coverage.

A total of ten test and five training targets were selected as test material. Figure 18 shows two of the targets used in the simulation. A description and picture of the 10 test targets used is presented in Appendix A.

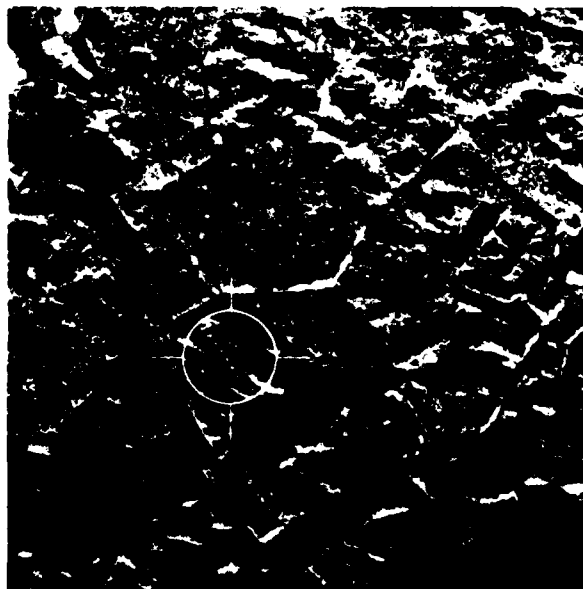

a. Vehicle convoy

Figure 18. Two examples of SAR target scenes.



VG-3839

b. Supply depot

Figure 18. Two examples of SAR target scenes (continued).

SECTION 3

RESULTS AND DISCUSSION

Crew size (one- and two-man crews), workload (threat densities averaging from zero to 14.1 (threats per minute), and mission phase (ingress, penetration, and SAR target acquisition) were study parameters in the simulation. Eight different performance measures were used to assess the effects of the study parameters on aircrew performance.

The results of the simulation are organized by category of aircrew performance measures; namely, aircraft flight control performance, threat detection and response (workload) performance, and SAR ground map target acquisition performance. The effects of the three study parameters are discussed in each of the three categories of performance measures. The results are depicted graphically in plots which use means as central tendency descriptive statistics with the exception of SAR target acquisition time which uses the median. Analysis of variance was used to test for the reliability of the effects of the study parameters on the various measures of operator performance. When a probability value is stated for a given parameter and performance measure (e. g., $p < 0.01$), it means that the performance difference(s) would be expected to occur by chance with the stated probability (e. g., less than one chance out of a 100). Analysis of variance summary tables are in Appendix B.

AIRCRAFT FLIGHT CONTROL PERFORMANCE

The pilots' ability to control aircraft altitude within ± 1000 feet of the commanded altitude and aircraft heading within ± 5 degrees of the commanded heading during the ingress and penetration phases was assessed. During the ingress phase, there were no threats, thus workload was at a minimum. During the penetration phase, threat density (workload) was varied from zero to 14.1 threats per minute. When the radar turn-on point was reached, the pilot selected autopilot, thus flight control performance was not assessed during the SAR target acquisition phase.

The effects of crew size on aircraft altitude and heading control for the ingress and penetration phases are shown in Figures 19 and 20. It is clear that there is no difference in a one- or two-man crew's ability to pilot the aircraft in the ingress phase where the workload is low. The two-man crew, however, was superior to the one-man crew in the penetration phase where target threats were introduced to increase crew workload. The two-man crews were able to control altitude within ± 1000 feet 96 percent of the penetration phase compared to 78 percent for the one-man crews. Heading control during the penetration phase suffered less performance degradation; although, the two-man crews were definitely better than the one-man crews. The two-man crews were within the ± 5 degrees tolerance 99 percent of the time compared to 92 percent of the time for the one-man crews.

The larger degradation of altitude control contrasted with heading control in the one-man, two-man comparison is probably caused by the pilots' interpretation of the relative importance of controlling the two flight

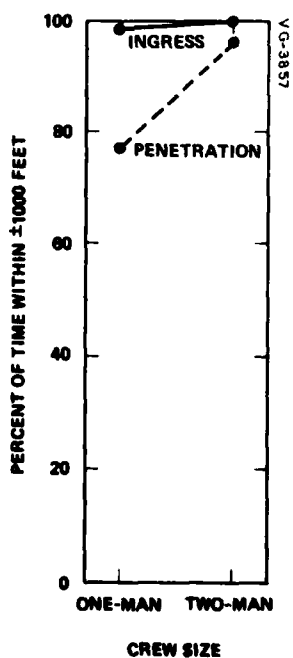

Figure 19. Crew-size effects on aircraft altitude control.

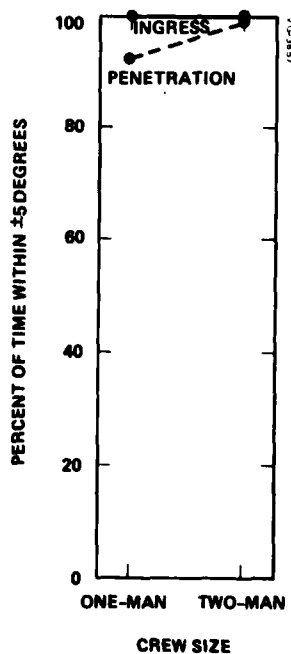

Figure 20. Crew-size effects on aircraft heading control.

parameters. The simulated mission was flown at 10,000 feet altitude. Deviation from this altitude by as much as 4000 feet would have little effect on mission success. Large errors in heading control, however, could affect mission success. In order for the SAR to map the required target area, the aircraft had to be within ± 5 degrees of the required heading at the radar turn-on-point. This was emphasized to the pilots during training. It was, therefore, likely that the pilots paid more attention to heading control than altitude control. Thus when threats were introduced in the penetration phase and workload became large, the pilots devoted more time to heading control and hence degradation of heading control performance was less than for altitude control.

The performance differences due to crew size and mission phase on altitude control were statistically reliable beyond the 0.01 probability level, as was the interaction between crew size and mission phase. For heading control, performance differences due to crew size, mission phase, and the interaction between crew size and mission phase were statistically reliable beyond at the 0.05, 0.01, and 0.05 probability levels, respectively.

Figure 21 shows the effect of threat density and crew size on aircraft altitude control. The degradation of aircraft altitude control with increased threat density was much more severe for the one-man crews than the two-man crews. There was very little performance loss with the two-man crews until threat density reached 12.2 threats per minute. At the highest threat density, altitude control performance was within the ± 1000 feet tolerance 92 percent of the time for the two-man crews. For the one-man crews, altitude control performance ranged from 100 percent at zero threats to 68 percent at the highest threat density. Two-man crews were clearly superior to one-man crews in the control of aircraft altitude with increased workload, and the heavier the workload the greater was the benefit of having a second crewman.

The effects of threat density on one- and two-man crews' aircraft heading control performance were smaller than for altitude control. Figure 22 shows that performance for the two-man crews was affected only at the highest threat density. Heading control performance was affected at all threat densities for the one-man crews, although the performance degradation

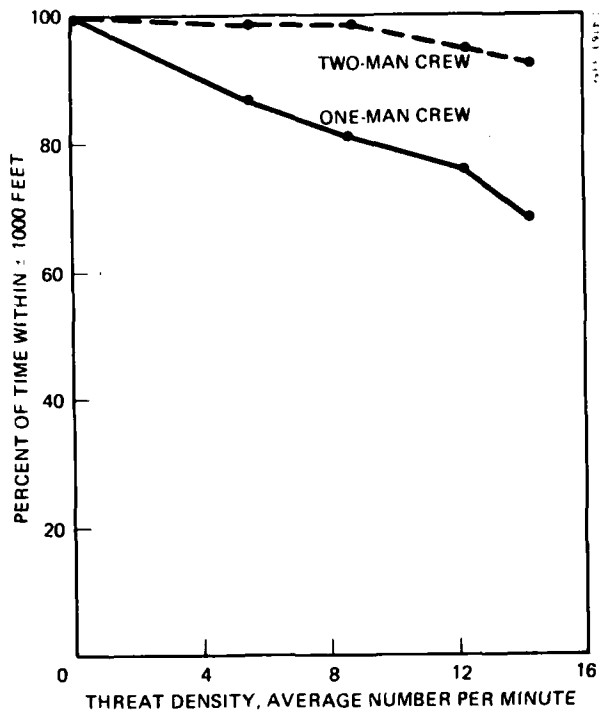

Figure 21. Effects of threat density and crew size on aircraft altitude control performance.

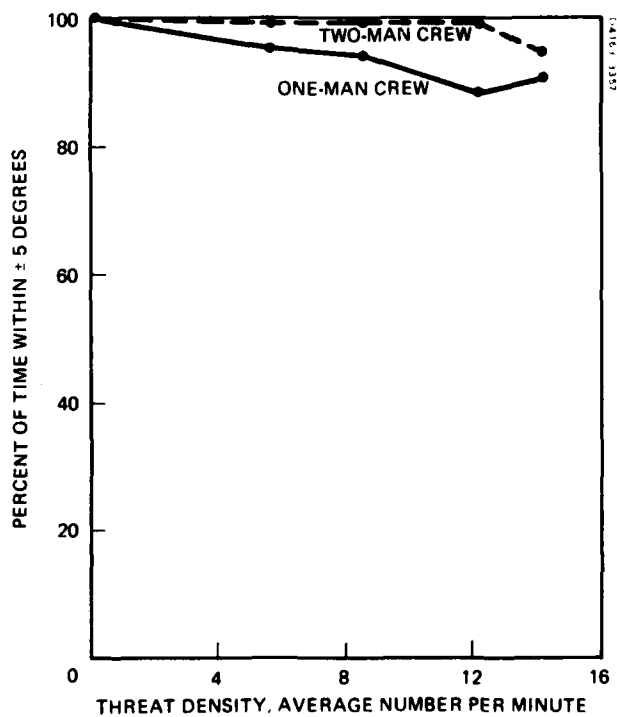

Figure 22. Effects of threat density and crew size on aircraft heading control performance.

was not great. As previously discussed, the smaller degradation of heading control compared to altitude control with increased threat density was probably due to the perceived relative importance of controlling the two flight parameters during the simulation.

THREAT DETECTION AND RESPONSE PERFORMANCE

The one- and two-man TAC crews were required to make four types of responses to the simulated threats during the missions. The number of threats that occurred during the penetration and SAR target phases were varied from zero to 14.1 threats per minute to vary the crews' workload. There were never any threats in the ingress phase. The four types of responses were 1) detection of threat indications on the RWR display and activating the correct countermeasures (RWR threat response), 2) detection of RWR outside lights and calling out the location (altitude) of the lights, 3) detection of non-RWR outside lights and calling out the location (bearing and altitude) of the lights, and 4) detecting, designating, and launching missiles against air-to-air radar targets. The RWR threat response and air-to-air radar target threats were in-cockpit visual tasks; the RWR and non-RWR outside light threats were out-of-cockpit visual tasks.

RWR Threat Response

Crew size had no effect on the probability of correctly responding to RWR threats ($p > 0.25$) as shown in Figure 23. A statistically reliable ($p < 0.05$) interaction between mission phase and threat density is depicted in Figure 24. Two effects are apparent from Figure 24. As threat density increased, the probability of correct RWR threat response decreased, and while RWR threat response performance for the two mission phases was nearly equivalent at 5.5 threats per minute, performance degraded more rapidly in the SAR target acquisition phase at the higher threat densities.

The greater and more rapid fall off of RWR threat response performance in the SAR target acquisition phase is probably because the task of locating and designating the target on the SAR ground map required more time and attention than the aircraft flight control task that took place in the

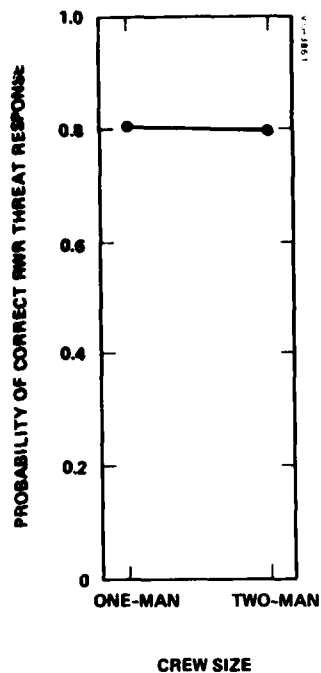

Figure 23. Crew size effects on RWR threat response performance.

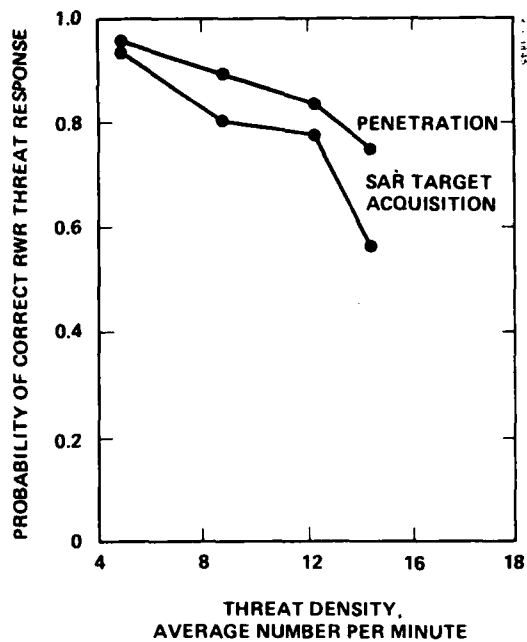

Figure 24. Threat density and mission phase effects on RWR threat response performance.

penetration phase. In other words, the SAR target acquisition task was more demanding than the flight control task. Hence, there was less time for the crews to respond to RWR threats in the SAR target acquisition phase, and at the higher threat densities, performance degraded more rapidly.

The degradation of RWR threat response performance with increased threat density was anticipated; however, it was also anticipated that the two-man crews would suffer less performance degradation than the one-man crews. This was not the case. The two-man crews were not substantially better at RWR threat detection and response than were the one-man crews, regardless of the threat density or the mission phase.

RWR Outside Light Detection

After a crewman had detected a RWR threat and activated the appropriate countermeasure, he was to look outside the cockpit (if the threat

bearing indicated on the RWR display was between the eleven and five o'clock positions) and determine the altitude (high, level, or low) of the outside light.

The number of RWR outside lights that were detected by the crews was affected by crew size, mission phase, and threat density. All three parameters had statistically reliable effects on RWR outside light detection (crew size, $p < 0.05$; mission phase, $p < 0.001$; and threat density, $p < 0.001$). There were no statistically reliable interactions among the three parameters ($p > 0.20$ in all cases).

Figure 25 shows the effect of crew size on RWR outside light detection; 52 percent of the lights were detected by one-man crews and 70 percent by the two-man crews. The addition of a second crewman resulted in a 35 percent improvement of outside light detection performance.

The probability of outside light detection in the penetration and SAR target acquisition phases is shown in 26. As was the case for aircraft flight

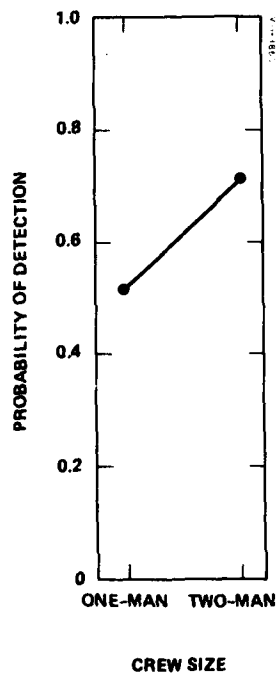

Figure 25. Effect of crew size on RWR outside light detection performance.

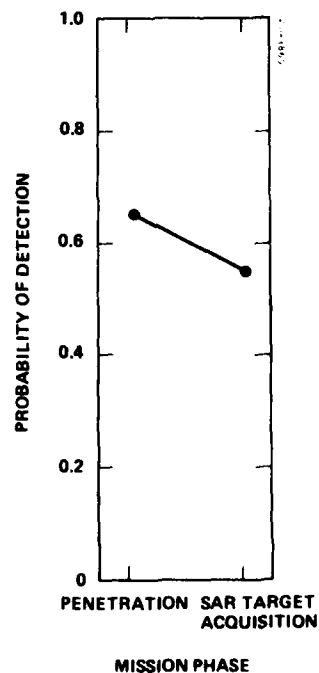

Figure 26. Mission phase effects on RWR outside light detection performance.

control, performance was poorer in the SAR target acquisition phase than the penetration phase -- 0.56 versus 0.66 probability of detection.

As threat density increased from 5.5 to 14.1 threats per minute the probability of RWR outside light detection decreased from 0.73 to 0.49. This effect is illustrated in Figure 27 which shows threat density to have an approximately linear effect on RWR outside light detection performance.

The amount of time available to the crews to look outside the cockpit to determine the altitude of the RWR outside lights was less in the SAR target acquisition phase and decreased as threat density increased, and the addition of a second crewman resulted in there being more time available to detect the lights. The performance improvement gained with the second crewman was approximately constant across all threat densities.

Non-RWR Outside Light Detection

Whereas RWR outside lights were cued by the RWR display, non-RWR outside lights were not. To detect non-RWR outside lights, the crews

had to periodically search the outside lights and call out the bearing and altitude of any illuminated lights.

Crew size had a major effect on the probability of detection of non-RWR outside lights ($p < 0.001$). As shown in Figure 28, the probability of detecting non-RWR lights was 0.35 for one-man crews and 0.62 for two-man crews. The addition of a second crewman resulted in a major increase in the time available to search outside the cockpit and detect non-RWR lights.

Although slightly more non-RWR lights were detected in the SAR target acquisition phase than the penetration phase -- detection probabilities of 0.51 and 0.46 -- the performance

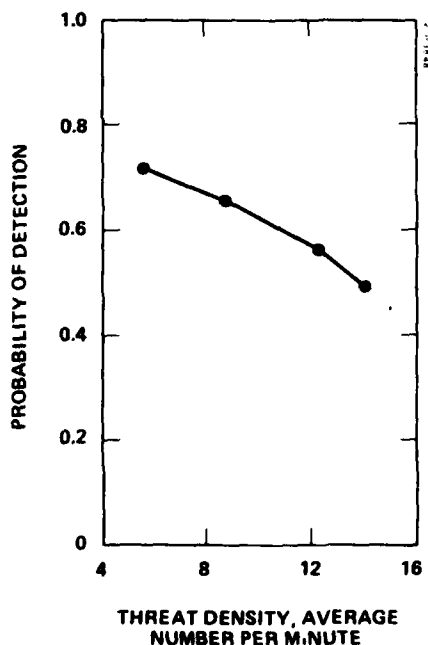

Figure 27. RWR outside light detection performance and threat density.

difference was not statistically reliable ($p > 0.25$). Therefore, it must be concluded that there was no difference in the probability of non-RWR outside light detection between the two mission phases. Figure 29 shows the small difference due to mission phase.

The effect of threat density on non-RWR outside light detection is shown in Figure 30. The effect was statistically reliable at the 0.001 probability level. As shown in Figure 30, detection probability dropped from 0.57 at 8.6 threats per minute to 0.39 at 12.2 threats per minute. Detection probability remained essentially constant between the two lowest threat densities and between the two highest densities. The slight increases in detection probability seen in Figure 30 were not statistically reliable ($p > 0.25$). Increasing threat density from 5.5 to 8.6 threats per minute or from 12.2 to 14.1 threats per minute apparently did not substantially change the crews' workload with regard to non-RWR outside light detection. The

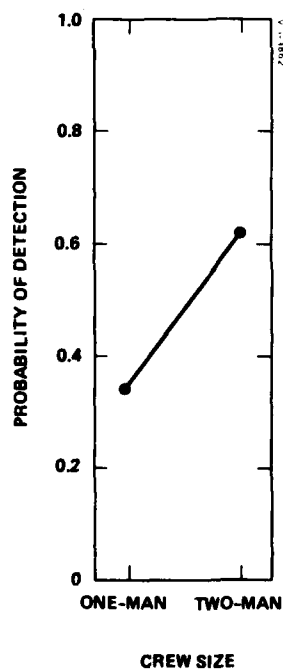

Figure 28. Crew size effects on detection of non-RWR outside lights.

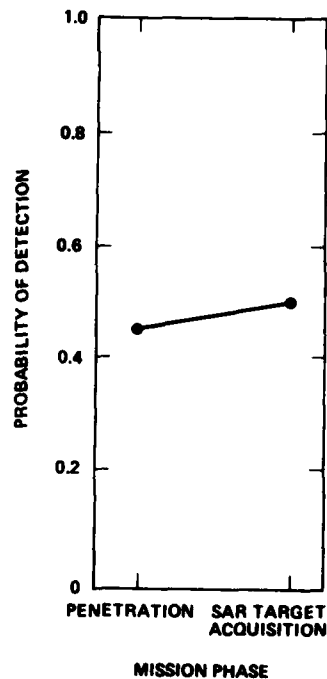

Figure 29. Mission phase effects on detection of non-RWR outside lights.

increase from 8.6 to 12.2 threats per minute, however, caused a large step increase in workload, and non-RWR outside light detection performance dropped sharply.

Air-to-Air Radar Target Threats

Air-to-air radar targets were presented on the vertical situation display during the penetration mission phase. The radar was in the ground map mode during the SAR target acquisition phase; therefore, air-to-air radar target threats did not occur in that phase. If a crewman detected an air-to-air radar target that was within 20-nautical miles range on the vertical situation display, he designated the target and commanded radar super-search. When radar lock-on occurred, an air-to-air missile was launched.

There was no difference in one- and two-man crews ability to respond to air-to-air radar threats, regardless of threat density. Figure 31 shows the main effect of crew size in which both one- and two-man crews had a 0.54 probability of detection.

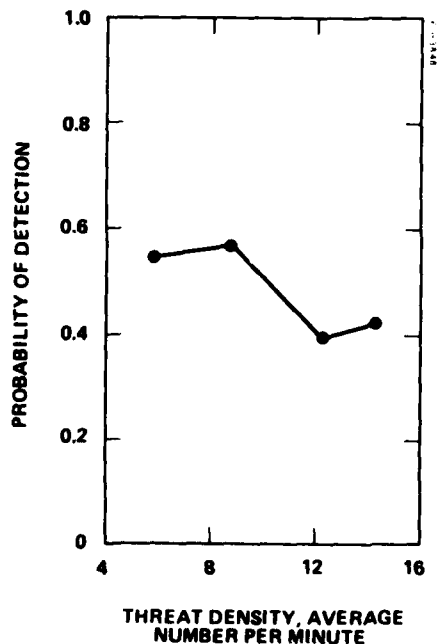

Figure 30. Effect of threat density on detection of non-RWR outside lights.

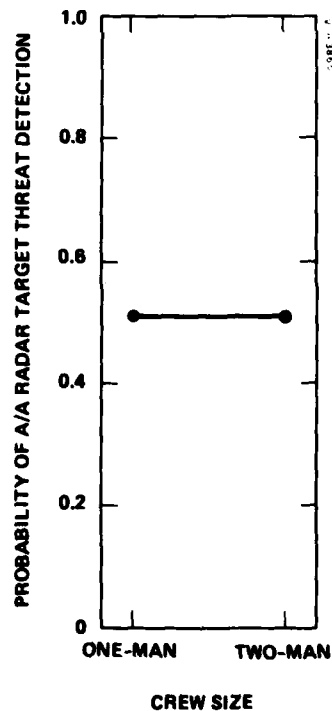

Figure 31. Effect of crew size on air-to-air radar threat detection performance.

Since the pilot monitored the VSD to control aircraft flight performance and air-to-air targets were presented on the VSD, the addition of a second crewman to search for air-to-air radar targets would not be expected to result in much improvement in air-to-air radar target detection performance. The typical division of responsibilities of two-man crews in the penetration phase was for the pilot to handle flight control and air-to-air radar targets and the second crewman to handle RWR and non-RWR threat detection. With such a division of tasks, one would not expect any substantial improvement in air-to-air radar target detection, but a substantial improvement in the detection of RWR and non-RWR outside lights could be expected. Both these expectations occurred.

As was the case with flight control performance, RWR threat response, detection of RWR outside lights, and detection of non-RWR outside lights, increased threat density resulted in decreased aircrew performance. Figure 32 illustrates the performance degrading effect of increased threat

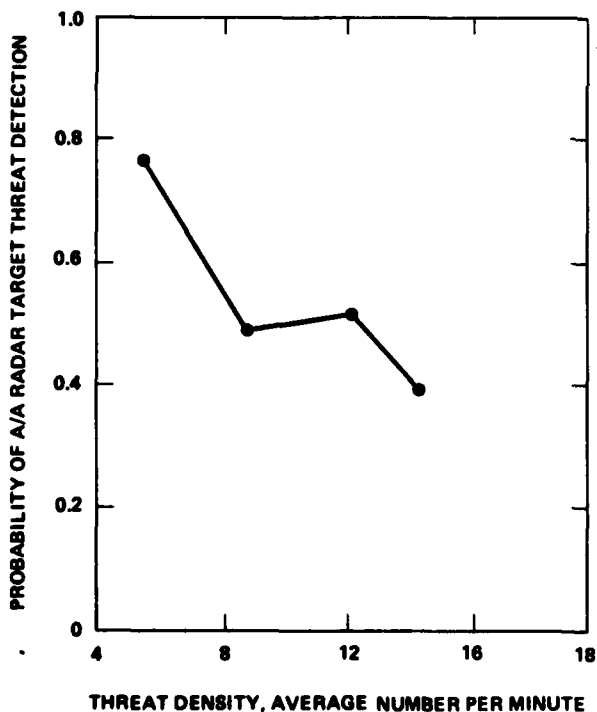

Figure 32. Effect of threat density on air-to-air radar target threat detection performance.

density on air-to-air radar target detection performance. Performance ranged from a 0.77 probability of detection at 5.5 threats per minute to 0.38 probability of detection at 14.1 threats per minute. There was no appreciable change in performance between threat densities of 5.5 and 8.6 threats per minute.

Comparison of Inside and Outside Cockpit Threat Response Performance

The four types of threats that occurred during the simulation can be categorized into threats that required in-cockpit monitoring and threats that required

outside-cockpit monitoring. In the penetration mission phase, RWR threat response and air-to-air radar targets required in-cockpit monitoring; RWR and non-RWR outside lights required outside-cockpit monitoring. In the SAR target acquisition mission phase, RWR threat response required in-cockpit monitoring; RWR and non-RWR outside lights required outside-cockpit monitoring.

Figure 33 shows the comparison of inside-cockpit threats and outside-cockpit threats for one- and two-man crews and the four threat densities for the penetration phase. It is clear that the principal benefit of a second crewman for threat detection and response performance is for the outside-cockpit threats. The second crewman reduces the crew workload such that more time is available to search outside the cockpit. The two-man crews detected 35 to 78 percent more outside cockpit threats across the four threat densities than did the one-man crews. On average, the two-man crews'

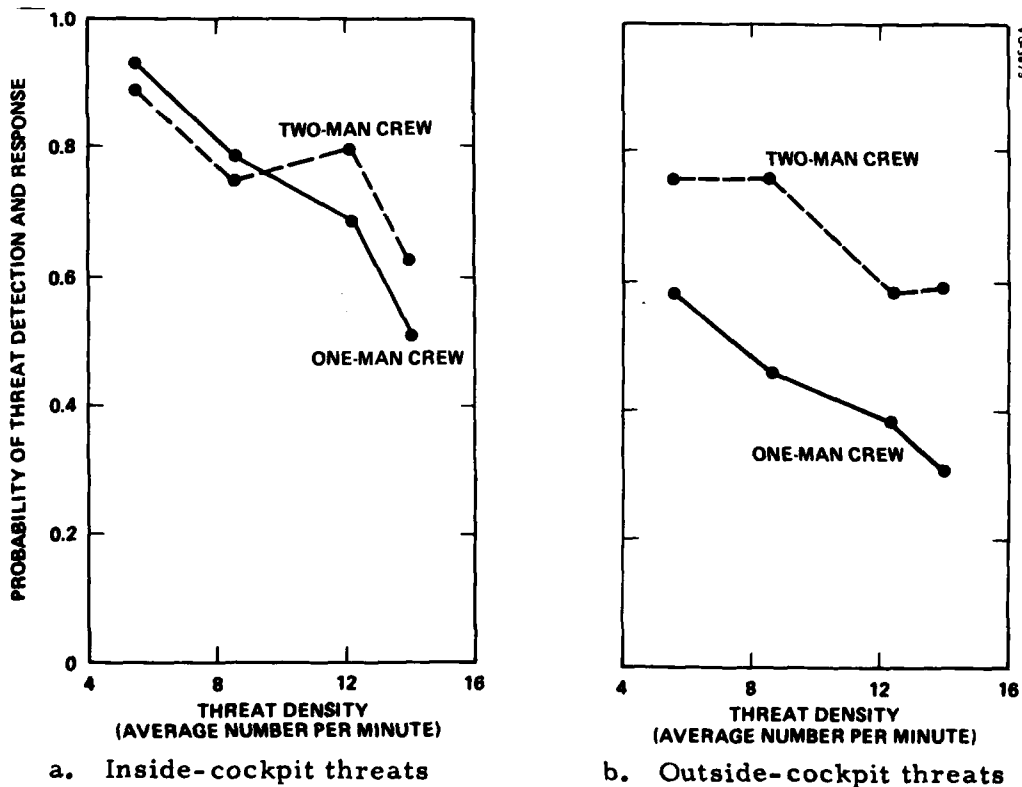

Figure 33. Comparison of inside- and outside-cockpit threats for one- and two-man crews and threat densities in the penetration mission phase.

outside light detection performance was 53 percent better than the one-man crews' performance.

For inside-cockpit threats the one-man crews were negligibly better than the two-man crews at the two lowest threat densities. At the two highest threat densities, the two-man crews were superior. Thus while crew size had a major effect on outside cockpit threats at all threat densities, the benefits of a second crewman only occurred at high threat densities for inside-cockpit threats.

The comparison of inside- and outside-cockpit threat detection and response performance during the SAR target acquisition phase is shown in Figure 34. Again, the two-man crews were highly superior to the one-man crews in outside-cockpit threat detection.

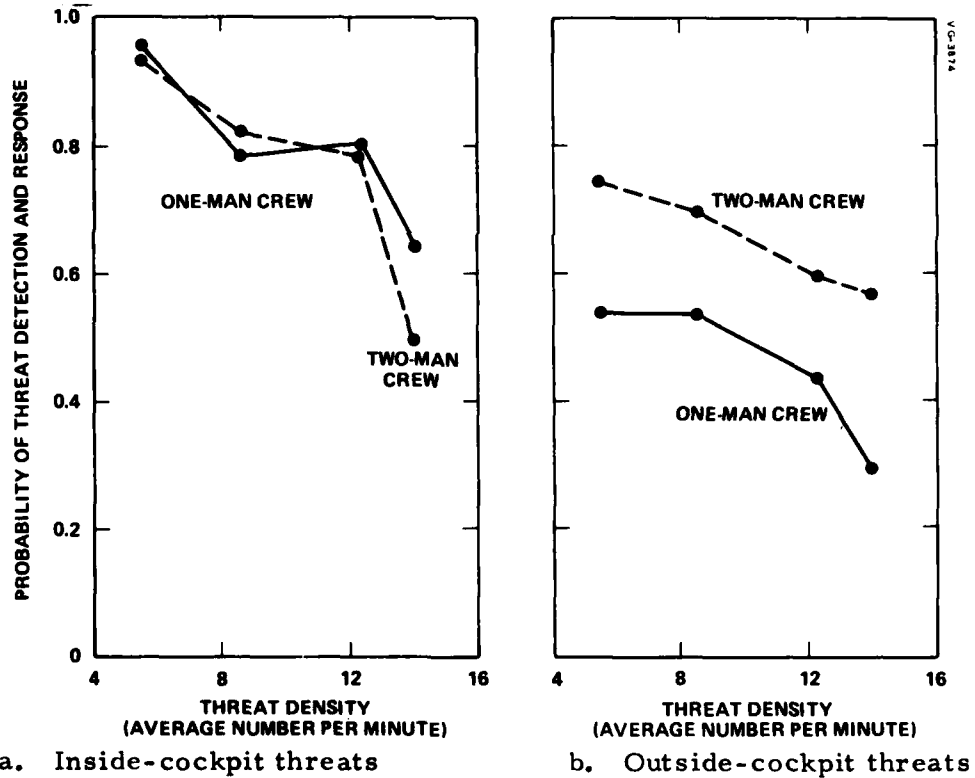

Figure 34. Comparison of inside- and outside-cockpit threats for one- and two-man crews and threat densities in the SAR target acquisition mission phase.

The performance differences between one- and two-man crews for inside-cockpit threats were negligible except at the highest threat density level. At the highest threat density, one-man crews detected more inside-cockpit threats than did the two man crews. This seemingly odd finding was probably a consequence of high workload and a crew coordination problem.

The simulation was set up such that with two-man crews the rear-seat operator had a RWR display but not a countermeasures control panel. The pilot in the front seat had a countermeasures control panel but not a RWR display. Thus, the rear-seat operator had to tell the pilot the type of RWR threat that had been encountered in order for the pilot to initiate the appropriate countermeasure response. The simulation was deliberately set up this way to force verbal communications and task coordination in the two-man crews, knowing that such a scheme was poor cockpit design.

The arrangement worked satisfactorily except at the highest threat density in the SAR target acquisition phase. In the SAR target acquisition phase, the rear-seat operator's principal task was to locate and designate a target on the SAR ground map. Monitoring the RWR display to determine the type of RWR threat and communicate this to the pilot was an additional task imposed on the rear-seat operator. The rear-seat operators apparently were able to handle both tasks adequately except at the highest threat density where the workload became too great and performance broke down as evidenced by the poor in-cockpit threat detection performance.

Overall Threat Detection and Response Performance

Figure 35 shows threat detection and response performance taken across the four types of threats for one- and two-man crews, threat densities, and mission phases. Two-man crews were better able to handle the increased workload resulting from threat density. On average, the two-man crews detected 24 percent more threats than did the one-man crews. This 24 percent performance advantage was fairly constant across all threat densities in both mission phases.

The major performance difference between the penetration and SAR target acquisition mission phases was the rate of performance degradation with increased threat density. Performance degraded in a linear fashion in the penetration phase with increased threat density. In the SAR target acquisition phase, performance degradation with increased threat density was a quadratic function.

The difference in threat detection and response performance degradation caused by threat density for the two mission phases is probably due to nature of the operators' division of attention among tasks. In the penetration phase, the crews were required to control the aircraft and respond to threats. The flight control task required continuous or regularly periodic attention to keep aircraft altitude and heading within the tolerances, regardless of threat density. Since the pilot tried to maintain the same degree of

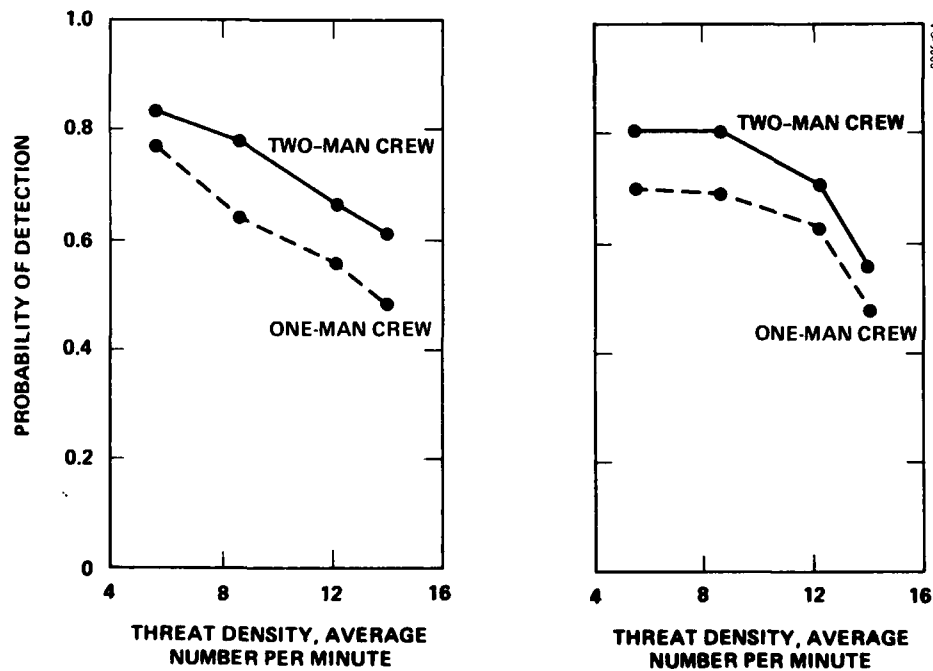

a. Penetration phase

b. SAR target acquisition phase

Figure 35. Overall effects of threat density on threat detection and response performance.

aircraft control at all threat densities, threat detection and response performance degraded in a linear manner as threat density increased.

In the SAR target acquisition phase, the crews were required to recognize and designate a target on the SAR ground map and respond to threats. The SAR target recognition and designation task did not require either continuous or periodic attention of the operator. The rear-seat operator could spend a block time of variable length on the SAR target recognition and designation task without serious consequences. Thus, if the threat response requirement became high, the rear-seat operator could interrupt the SAR target recognition and designation task to help the pilot deal with the threat workload. At some point, however, too frequent interruption of the SAR target acquisition task will result in reduced efficiency and degraded performance. At that point, the rear-seat operator has to decide whether to help the pilot deal with the threats and risk overflying the ground target before weapon delivery or concentrate on the SAR target recognition and designation task. Since the prime mission objective was air-to-ground strike, the likely result is a concentration on the SAR target recognition and designation task. This would explain why threat detection and response performance fell off so rapidly at the two highest threat densities in the SAR target acquisition phase.

SAR GROUND MAP TARGET ACQUISITION PERFORMANCE

Time from SAR turn-on until the rear-seat operator designated the target and probability of correct target recognition and designation were measured to assess the crews' ability to accomplish SAR target recognition and designation. Threat densities from zero to 14.1 threats per minute occurred during the SAR target acquisition task.

Analysis of variance of the time and probability measures indicated that neither crew size or threat density had statistically reliable effects on SAR target acquisition performance (p 's > 0.25). This is not an uncommon finding in sensor image target recognition studies with small sample sizes because of the typically large variability in such studies. The SAR target acquisition results described below, while not statistically significant, are

assumed to be indicative of what one would expect to occur in actual air-to-ground radar strike systems.

The effects of crew size and threat density on median SAR target acquisition time are shown in 36. The two-man crews required less time to recognize and designate the targets than the one-man crews at all but the highest threat density. The one-man crews required less time than the two-man crews at the highest threat density.

Figure 37 shows the effects of crew size and threat density on the probability of correct SAR target acquisition. Again the two-man crews were superior to one-man crews at all but the highest threat density where the one-man crews were superior.

At first glance, one might argue that at very high threat densities (high workloads) a single-man crew will do better than a two-man crew at a ground map target recognition task. This is not likely to be the case. The crew coordination problem resulting from the separation of RWR threat detection and RWR threat response discussed earlier may have interfered with the SAR target acquisition task at the highest threat density and degraded

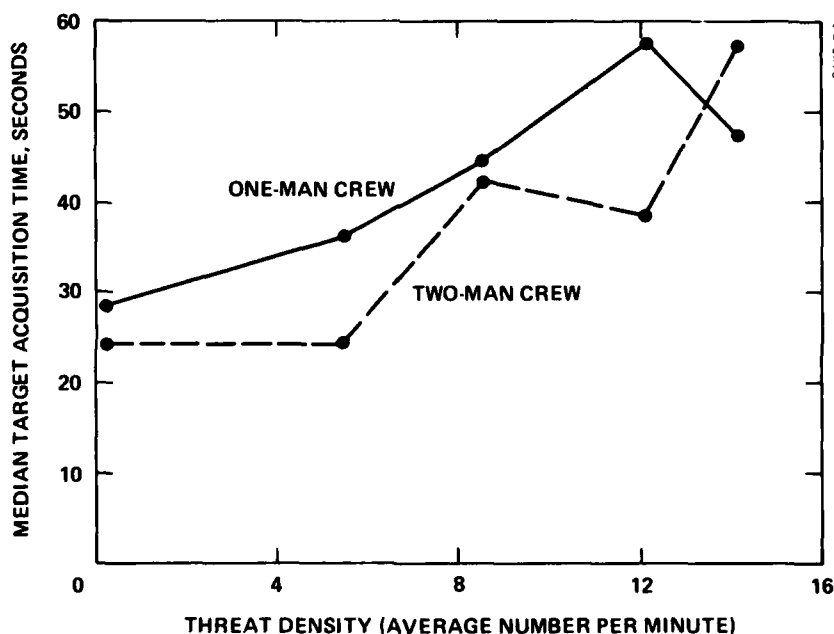

Figure 36. Crew size and threat density effects on time to acquire SAR targets.

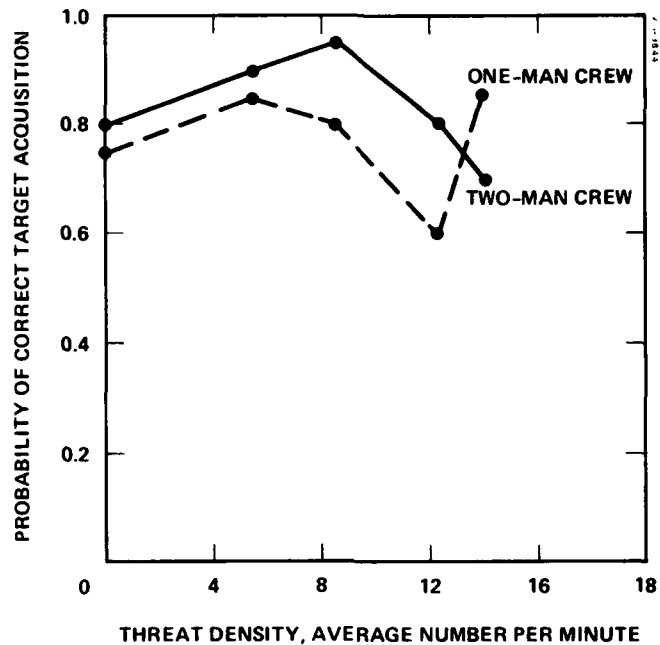

Figure 37. Crew size, threat density, and probability of correct SAR target acquisition.

SAR target acquisition performance. Thus the finding that the one-man crews were better than the two-man crews at the highest threat density may be an artifact of the simulation procedures for RWR threats.

A second and more likely explanation is that at very high threat densities the one-man crews made the decision to ignore threats until they completed the SAR target acquisition task. This explanation is supported by the outside-cockpit threat detection performance. Outside-cockpit threat detection probability dropped from 0.59 at 12.2 threats per minute to 0.57 at 14.1 threats per minute for two-man crews. For one-man crews the drop was from a 0.44 to a 0.29 probability of outside-cockpit threat detection. The rear-seat operators in two-man crews may also have made the decision to ignore threats at a high threat level; however, the pilot who had placed the aircraft on autopilot could spend 100 percent of his time responding to the threats. Though one-man crews recognized SAR targets better than

two-man crews at the highest threat density, they sacrificed threat detection and response performance to do so.

The general effect of threat density on SAR target acquisition time was to increase the time to recognize and designate targets with increasing threat density, except at the highest threat level for the one-man crews. Increasing workload by increased threat density increases the elapsed time to complete the SAR target acquisition task because the operator expends more time responding to the threats.

Increased threat density actually increased the probability of correct SAR target acquisition as threat density increased from zero to 8.6 threats per minute for two-man crews and for one-man crews between zero and 5.5 threats per minute. Further increases in threat density caused SAR target recognition probability to decrease, except at the highest threat level for one-man crews. This up-and-down performance variation is not an uncommon finding in behavioral research. Moderate increases in workload can cause people to perform better at their assigned tasks. The increased workload can have the effect of increasing the operators' activation level, thereby improving his focus of attention on the task he is performing. Moderate workloads can also result in increased operator task efficiency. For example, the operator, knowing he has to perform under increased workload, may improve his method of scanning the SAR display and make better use of contextual cues, thereby increasing the probability of recognizing and designating radar targets.

Large increases in workload, of course, can overload the operators' capacity and result in performance degradation. Such an overload would be expected to occur sooner with one-man crews than with two-man crews in the simulation. The reduction in probability of correct SAR target acquisition that occurred at 8.6 threats per minute for one-man crews and 12.2 threats per minute for two-man crews confirms this expectation.

SECTION 4

CONCLUSIONS AND RECOMMENDATIONS

The simulation study described in this report was conducted to investigate crew size requirements for all-weather strike aircraft that might employ synthetic aperture radar systems for air-to-ground weapon delivery. The answer to the one-versus two-man aircrew issue for all-weather strike aircraft is obviously dependent on multiple considerations. Considerations that were addressed in the present research effort were crew workload and crew tasks requiring inside- and outside-cockpit visual scanning.

Aircraft flight control performance, threat detection and response performance, and SAR target acquisition performance for one- and two-man crews were evaluated in the simulation. The implications of the results of the simulation in each of these three categories of aircrew performance are discussed in this section.

AIRCRAFT FLIGHT CONTROL PERFORMANCE

Under low workload, there was no difference between the one- and two-man crews' aircraft flight control performance. Under moderate and high workloads, two-man crews were superior to one-man crews in both aircraft altitude and heading control. The superiority of two-man crews became more pronounced as workload increased.

The flight control task in the simulation was relatively simple in that no evasive maneuvering or complex flight control task, such as terrain following, was required. An even greater advantage of two-man crews would be expected for missions requiring complex flight control tasks.

The superiority of the two-man crews during moderate and high workloads in the simulation may in part be due to the nature of the threat detection and response tasks that were used to vary workload. The threat detection and response tasks required both rapid response and outside-cockpit visual scanning. Boeing (1967 and 1968) in their simulation found no difference between one- and two-man crews' flight control performance; however, the Boeing simulation did not use outside-cockpit visual tasks to vary workload or tasks that required immediate response. Under low threat environment

flight conditions where complex maneuvers are not required, little advantage would accrue from a second crewman. Significant performance improvements with two-man crews with regard to aircraft flight control could be expected: 1) when the flight control task is complex and the pilot has little available time for other tasks as in terrain following, 2) when considerable outside visual scanning is required, as in high threat environments, and 3) when major aircraft systems failures occur.

THREAT DETECTION AND RESPONSE PERFORMANCE

Variation of crew workload in the simulation was accomplished by presenting different types of simulated threats in varying densities. The different types of threats required different aircrew responses which were categorized into threats that required in-cockpit visual tasks and out-cockpit visual tasks.

The intent of the simulation was to utilize these simulated threats as a means of varying crew workload that required both in-cockpit and out-cockpit tasks. It was not the purpose of the simulation to assess actual real-world aircrew threat detection and response capability; hence, the simulation findings should not be interpreted as an absolute indication of one- and two-man aircrew performance against actual threats.

A major and significant result of the simulation was the large superiority of two-man crews in outside-cockpit threat detection. The argument presented in the Navy position paper that advantages of a two-man aircraft accrue primarily because 1) the two-man crew can sight and acquire targets quickly while maintaining six o'clock surveillance and SAM lookout and (2) the ability of the second crew member to concentrate attention on sophisticated multiple target threats and ECM while the pilot flies the aircraft and maintains the essential visual surveillance were shown to be valid.

The lack of an appreciable advantage in the detection and response to inside-cockpit threats by two-man crews is in agreement with the findings of the Boeing (1967 and 1968) simulation where it was found that a one-man crew can perform standard flight systems management tasks as effectively as a two-man crew.

A major conclusion that can be derived from the simulation is that a two-man crew will be able to maintain outside visual surveillance over a large volume of space far better than a one-man crew. The implications of this conclusion for aircraft/crew survival in hostile environments are obvious.

SYNTHETIC APERTURE RADAR TARGET ACQUISITION PERFORMANCE

At the zero threat level, the two-man crews were slightly superior to one-man crews in the time (5 seconds faster) required to recognize and designate SAR targets and the probability (5 percent higher) of correctly recognizing and designating the SAR targets. Since in the SAR target acquisition phase at zero threat density there were no other tasks (no flight control and no threats), it must be concluded that the rear-seat operators used in the simulation were superior to the one-man crew pilots in their ability to recognize and designate targets on SAR ground maps. As threat density increased, the two-man crews' SAR target acquisition performance degradation was slightly less than for one-man crews. Thus, there is a slight advantage in favor of the two-man crew in SAR target acquisition performance with moderate workloads. The finding is in agreement with the Boeing (1967 and 1968) simulation in which two-man crews visually acquired prebriefed ground targets sooner than one-man crews.

The superiority of one-man crews at the highest threat density which was caused by the one-man crews ignoring outside-cockpit threats until the SAR target task had been completed is of considerable importance. When an aircraft is in range for air-to-ground target acquisition to occur, the threat density in hostile environments will be the highest. While two-man crews could maintain outside visual surveillance during the SAR target acquisition phase at the highest threat density, the one-man crews could not. Thus one-man crews can perform air-to-ground SAR target acquisition at high workloads effectively only if they sacrifice outside-cockpit visual tasks.

The principal advantage of a two-man crew is for outside-cockpit visual surveillance. Some improvement of flight control and air-to-ground target acquisition performance under moderate to heavy workload may be expected with two-man aircraft; however, the performance improvement does

not appear to be substantial. The key argument for a two-place SAR air-to-ground strike aircraft, therefore, is the increased survivability in hostile environments by virtue of increased visual surveillance and detection of threats. Two-man aircraft, however, are more expensive, require greater manpower, and larger training programs than do single-place aircraft. In the final analysis, cost must be traded against aircraft survivability in hostile environments.

RECOMMENDATIONS FOR FUTURE CREW SIZE RESEARCH

Total System Considerations

The present study examined various components of crew performance over a wide range of crew tasks and task loading. In general, the results demonstrated an increased capability with the addition of a second crew member. It does not necessarily follow, however, that the improved crew performance will result in a system that more effectively meets the objectives of the mission. Total system performance, judged in terms of the mission, combined with cost provides the ultimate criterion by which a one- versus two-man crew decision must be made.

For example, the aerodynamic capability of a two-man aircraft may be less than that of a one-man aircraft, and it is possible for this reduced aircraft performance to offset any gain in crew performance resulting from the second crew member. On the other hand, it may be that for the intended mission the reduced aircraft performance is of little consequence. Only by a careful analysis of the mission requirements and system capabilities can the full impact of crew size be determined.

The cost impact of crew size can be considerable. Two-man aircraft can be expected to have a higher initial cost and recurring maintenance costs will be higher because of the increased complexity of the two-man cockpit configuration. By doubling the number of crewmen, costs of training and proficiency maintenance will rise substantially as will costs for salaries, dependents, and the increased number of support personnel. All of these additional costs must be weighed against the benefit of increased aircraft survivability likely to result from a two-man crew.

Many other system performance parameters can and should be identified and their cost impact assessed. The interactions among these various parameters also need to be identified and integrated into a system performance and cost prediction equation. Data for this portion of a prediction equation can be obtained, to a major extent, by analysis and examination of existing systems and their history. An assessment of the impact and interaction of these system variables on crew performance and of crew performance on total system effectiveness will require additional behavioral research.

Man-Machine System Model

To facilitate this research a conceptual model of the man and the machine is needed. Initially this model can be global and relatively simple; however, as the understanding of the human operator improves the model will have to become increasingly sophisticated. A possible global model of the man-machine system is shown in Figure 38 which indicates that from a

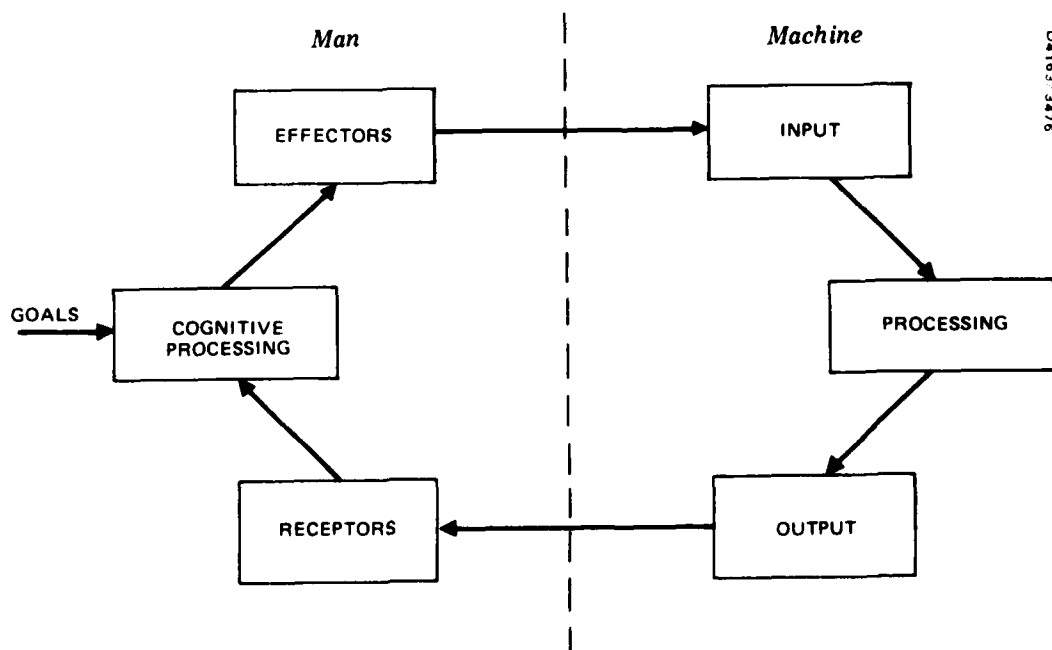

Figure 38. Man-machine system model.

systems standpoint both the man and the machine share common characteristics. Both have input and output mechanisms separated by a processing element.

A major difference lies in the accessibility of the various elements to manipulation by the system designer. All of the elements and links in the machine can be readily modified but the characteristics of the operator are relatively fixed and can only be slightly modified through training. This, of course, does not mean that the operator's performance cannot be influenced by the system designer. On the contrary, major differences can be effected by manipulating the machine and the two links between the man and the machine. If the links are optimized, then maximum communication between the man and the machine can result. Further, if the processing tasks required of the man are those for which he is best suited, then maximum human information processing can be achieved.

If the system designer is to accomplish this goal of an optimum system, an adequate model and understanding of the human operator will be necessary. Considerable work has already been accomplished in this direction, and the model of Figure 38 can be expanded to reflect knowledge concerning selective attention, short term memory, sensory encoding, decision processes, response selection, feedback mechanisms, and so on. This work needs to continue and can best be accomplished in a laboratory setting where the various elements and links can be isolated and manipulated. Once an adequate model of the operator has been obtained, optimum allocation of tasks to the man and the machine can be made and the communication between the two maximized.

With an understanding of a single crewman man-machine system, the model can be expanded to include a second crewman and other elements of the total system. For example, the addition of a second crewman will increase the number of possible communication links. In addition to man-machine links, man-man, and machine-machine links will also be of importance.

For example, suppose that the second crew member were added as a total duplication of the first crewman, including a second machine for him to operate. In this case the second operator would be in parallel with the first

and a slight improvement in system performance could be expected because of the redundancy in operation. This of course is a highly inefficient method of using the second crew member.

A potentially better utilization could be made by establishing the appropriate communication links and allocating different portions of the task to each operator. One operator would have one set of primary and secondary tasks and the other operator a complimentary set of tasks and priorities. In this way each operator could function at a lower workload and still provide a mechanism for redundancy. The presence of these additional communication links does not guarantee more efficient operation, however. It is possible for an inappropriately used link to become overloaded with a resultant decrease in performance as occurred with two-man crews at the highest threat density in the present study. Knowledge of the capabilities of the various communication links is a necessity.

Model Validity

A model of human performance must have both internal and external validity. Internal validity means that the model is interpretable, consistent, and correctly separates the various elements and their functions. External validity means that the model is generalizable and predicts to situations that have not been directly tested. Internal validity is most easily achieved in a laboratory situation where good experimental control allows only those processes under investigation to vary. External validity can only be determined by testing the model in realistic situations to insure that it will generalize correctly. The optimum research strategy to insure both internal and external validity will involve basic laboratory studies coupled with simulations at various levels of sophistication and actual field evaluations. The laboratory work would develop the basic model which would be verified using simulations. The more realistic simulations would also provide insight into aspects of performance not included in the model under test. These insights would then provide a basis for model expansion, again taking advantage of the controlled laboratory setting. By means of an interactive and iterative use of both avenues of research a model with high internal and external validity could be made available to the system planner who must decide how many crew members are required.

APPENDIX A
SAR TARGET TEST SCENES USED
IN THE SIMULATION

VC-3841

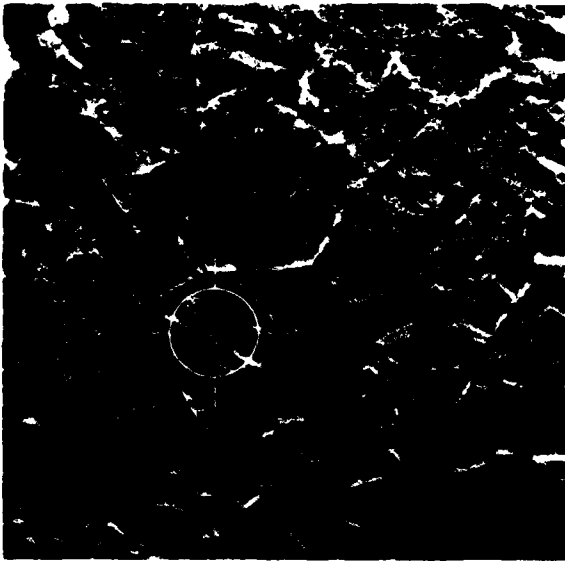

Figure A-1. Test Target Number 1

Target consisted of 10 vehicles arranged in a convoy formation with approximately 100 foot spacing. The target was located in a rectangular clearing. The area is heavily wooded.



Figure A-2. Test Target Number 2

Target was a headquarters and supply area in a heavily wooded area. A large concentration of vehicles was located in a large clearing approximately 1500 meters below the main target complex.

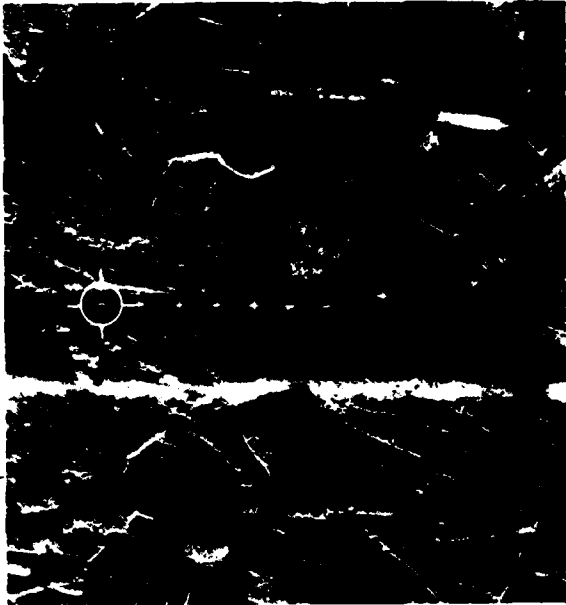

VC-3841

Figure A-3. Test Target Number 3

Target was a convoy of tanks moving west-southwest on a surfaced road. Vehicles were spaced approximately 200 meters apart.

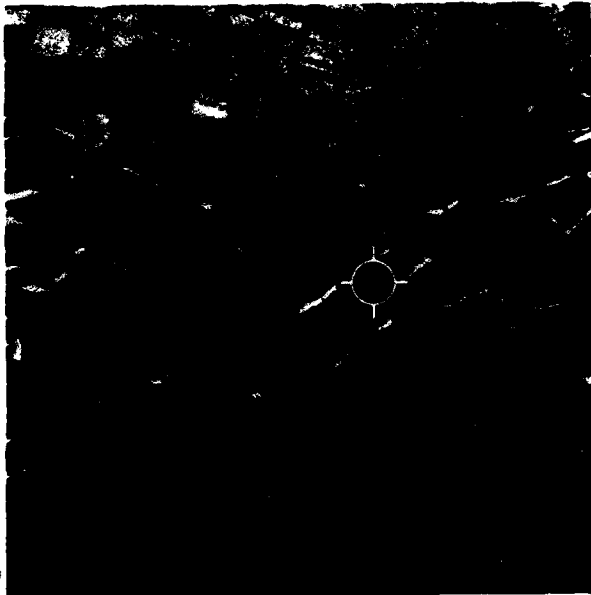
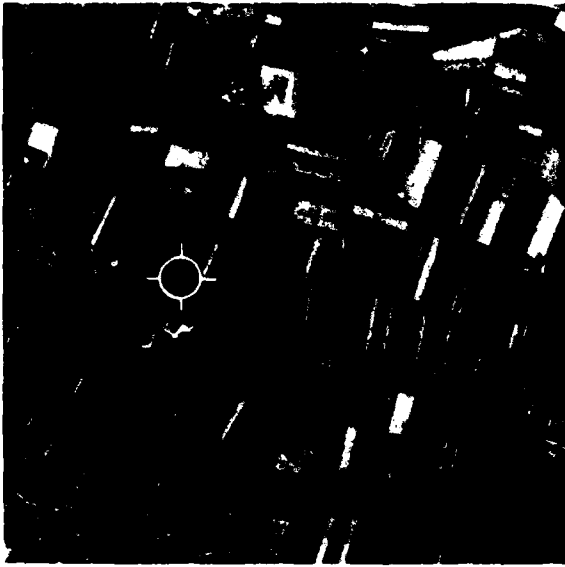

Figure A-4. Test Target Number 4

Target was a bridge located near a small town. Operators were to determine if bridge was down from previous strike. Operators were to cursor area where bridge was located.



VG-3841

Figure A-5. Test Target Number 5

Target was a single tank parked at a road junction 1200 meters north of a small town.



VG-3839

Figure A-6. Test Target Number 6

Target was a small bridge crossing a river. Several vehicles are proceeding towards the bridge approximately 1500 meters to the east.



VC-3330

Figure A-7. Test Target Number 7

Target is a AAA battery located above the airfield runway adjacent to a chain link fence.



Figure A-8. Test Target Number 8

Target is the control tower above and near the center of a dirt airstrip.

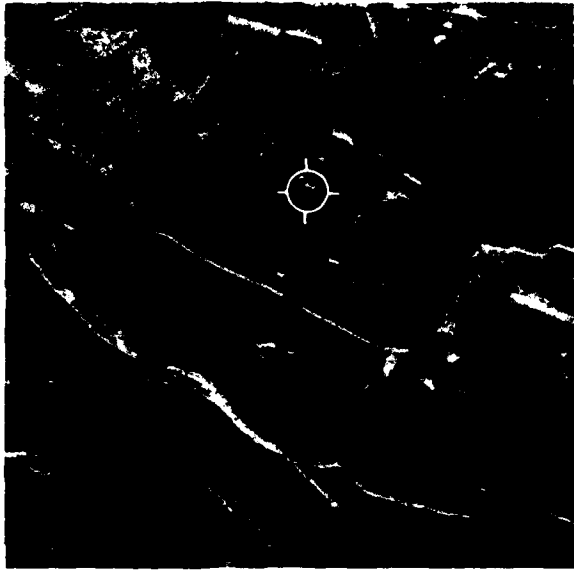

VC-3339

Figure A-9. Test Target Number 9

Target is a small supply depot (100 by 600 meters) in a wooded area. Target is located 1000 meters above bend in river.



Figure A-10. Test Target Number 10

Target is a rectangular storage depot (100 by 400 meters) with a chain link fence. Target is located 500 meters east of a small town above a road.

APPENDIX B
ANALYSIS OF VARIANCE
SUMMARY TABLES

TABLE B-1. ANALYSIS OF VARIANCE FOR AIRCRAFT ALTITUDE CONTROL

Source of Variance	Error Term	F-Ratio	Sum of Squares	Degrees of Freedom	Mean Square	Probability
Mission Phase (P)	PS(C)	36.1816	6045.883	1	6045.883	<0.001
Threat Density (T)	TS(C)	6.4057	859.8848	3	286.6282	<0.001
Crew Size (C)	S(C)	11.6180	3291.673	1	3291.673	<0.001
Subjects S(C)			5099.855	18	283.3252	
PT	PTS(C)	6.3535	980.6621	3	326.8872	<0.001
PC	PS(C)	20.0094	3343.534	1	3343.534	<0.001
TC	TS(C)	1.4672	196.9583	3	65.65274	>0.20
PS(C)			3007.770	18	167.0983	
TS(C)			2416.272	54	44.74577	
PTC	PTS(C)	1.6716	258.0093	3	86.00308	0.10 < 0.20
PTS(C)			2778.301	54	51.45000	

TABLE B-2. ANALYSIS OF VARIANCE FOR AIRCRAFT HEADING CONTROL

Source of Variance	Error Term	F-Ratio	Sum of Squares	Degrees of Freedom	Mean Square	Probability
Mission Phase (P)	PS(C)	15.9116	887.9741	1	887.9741	<0.001
Threat Density (T)	TS(C)	2.9026	174.1530	3	48.05099	0.01 < 0.05
Crew Size (C)	S(C)	7.5836	421.6243	1	421.6243	0.01 < 0.05
Subjects S(C)			1000.741	18	55.59671	
PT	PTS(C)	3.0020	179.5640	3	59.85468	0.01 < 0.05
PC	PS(C)	7.6912	429.2187	1	429.2187	0.01 < 0.05
TC	TS(C)	1.2816	76.89429	3	25.63142	>0.25
PS(C)			1004.521	18	55.80672	
TS(C)			1079.968	54	19.99940	
PTC	PTS(C)	1.2515	74.85840	3	24.95279	>0.25
PTS(C)			1076.660	54	19.93814	

TABLE B-3. ANALYSIS OF VARIANCE FOR RWR THREAT RESPONSE PROBABILITY

Source of Variance	Error Term	F-Ratio	Sum of Squares	Degrees of Freedom	Mean Square	Probability
Mission Phase (P)	PS(C)	13.5918	0.2665066	1	0.2665066	0.001 < 0.01
Threat Density (T)	TS(C)	51.6257	1.756146	3	0.5853821	<0.001
Crew Size (C)	S(C)	0.0722	0.2325862E-02	1	0.2325862E-02	>0.025
Subjects S(C)			0.5795606	18	0.3219781E-01	
PT	PTS(C)	3.6131	0.1396189	3	0.4653962E-01	0.01 < 0.05
PC	PS(C)	0.6325	0.1240209E-01	1	0.1240209E-01	<0.25
TC	TS(C)	2.3795	0.8094418E-01	3	0.2698139E-01	0.05 < 0.10
PS(C)			0.3529432	18	0.1960796E-01	
TS(C)			0.6123042	54	0.1133896E-01	
PTC	PTS(C)	1.3639	0.5270427E-01	3	0.1756809E-01	<0.25
PTS(C)			0.6955605	54	0.1288075E-01	

TABLE B-4. ANALYSIS OF VARIANCE FOR RWR OUTSIDE LIGHTS DETECTION PROBABILITY

Source of Variance	Error Term	F-Ratio	Sum of Squares	Degrees of Freedom	Mean Square	Probability
Mission Phase (P)	PS(C)	19.3670	0.3376200	1	0.3376200	<0.001
Threat Density (T)	TS(C)	12.0111	1.263977	3	0.4213257	<0.001
Crew Size	S(C)	6.0342	1.219752	1	1.219752	0.01 < 0.05
Subjects S(C)			3.63845	18	0.2021413	
PT	PTS(C)	2.3570	0.1881485	3	0.6271613E-01	0.20 < 0.10
PC	PS(C)	0.1898	0.3308296E-02	1	0.3308296E-02	>0.25
TC	TS(C)	0.4849	0.5103111E-01	3	0.1701037E-01	>0.25
PS(C)			0.3137894	18	0.1743274E-01	
TS(C)			1.894215	54	0.3507805E-01	
PTC	PTS(C)	0.7792	0.6220245E-01	3	0.2073415E-01	>0.25
PTS(C)			1.436853	54	0.2660840E-01	

TABLE B-5. ANALYSIS OF VARIANCE FOR NON-RWR OUTSIDE LIGHTS DETECTION PROBABILITY

Source of Variance	Error Term	F-Ratio	Sum of Squares	Degrees of Freedom	Mean Square	Probability
Mission Phase (P)	PS(C)	1.4004	0.7526428E-01	1	0.7526428E-01	0.25
Threat Density (T)	TS(C)	7.7255	0.9557392	3	0.3185797	< 0.001
Crew Size (C)	S(C)	21.8274	3.066355	1	3.066355	< 0.001
Subjects S(C)			2.528669	18	0.1404816	
PT	PTS(C)	1.7021	0.1547411	3	0.5158037E-01	0.10 < 0.20
PC	PS(C)	0.7919	0.4256248E-01	1	0.4256248E-01	> 0.25
TC	TS(C)	2.3052	0.2841791	3	0.9505969E-01	0.05 < 0.10
PS(C)			0.9674387	18	0.5374659E-01	
TS(C)			2.226824	54	0.4123748E-01	
PTC	PTS(C)	1.4015	0.1274177	3	0.4247258E-01	0.25
PTS(C)			1.636447	54	0.3030457E-01	

TABLE B-6. ANALYSIS OF VARIANCE FOR AIR-TO-AIR RADAR TARGET DETECTION PROBABILITY

Source of Variance	Error Term	F-Ratio	Sum of Squares	Degrees of Freedom	Mean Square	Probability
Threat Density (T)	TS(C)	30.2224	1.586267	3	0.5287558	< 0.001
Crew Size (C)	S(C)	0.0097	0.1240332E-02	1	0.1240332E-02	> 0.25
Subjects S(C)			2.304596	18	0.1280331	
TC	TS(C)	2.5532	0.1340097	3	0.4466990E-01	0.05 < 0.10
TS(C)			0.9447571	54	0.1749550E-01	

TABLE B-7. ANALYSIS OF VARIANCE FOR SYNTHETIC APERTURE
RADAR TARGET ACQUISITION TIME

Source of Variance	Error Term	F-Ratio	Sum of Squares	Degrees of Freedom	Mean Square	Probability
Threat (T)	TS(C)	1.0667	5628.887	4	1407.222	>0.25
Trials (L)	LS(C)	1.6035	1217.672	1	1217.672	0.25 < 0.20
Crew Size (C)	S(C)	0.7299	1429.432	1	1429.432	>0.25
Subjects S(C)			35252.73	18	1958.485	
TL	TLS(C)	1.5595	5100.457	4	1275.114	0.25 < 0.20
TC	TS(C)	0.1985	1047.307	4	261.8267	>0.25
LC	LS(C)	0.9525	723.2847	1	723.2847	>0.25
TS(C)			94984.69	72	1319.232	
LS(C)			13669.01	18	759.3892	
TLC	TLS(C)	1.2425	4063.454	4	1015.863	>0.25
TLS(C)			58869.16	72	817.6272	

REFERENCES

Anonymous, "Two seat versus single seat fighters." 2 May 1973

Autonetics Division, North American Rockwell, One-Man Crew Effectiveness Study for F-X. C7-2002/120, 21 August 1967.

Boeing Company, A Study of Crew Utilization for Multimission Fighter/Attack Aircraft. Phase II, Part C, Final Report, VFR Multimission Flight Simulator Tests. D6-53564, 24 May 1967.

Boeing Company, A Study of Crew Utilization for Multimission Fighter/Attack Aircraft. Phase II, Parts B and C, Final Report, Training Manual for Simulation Operational Procedures and Sub-system Management. D6-53565, May 1968.

Carel, W. L. and Hershberger, M. L., Operator Performance in Real-Time Target Acquisition, ASD 7539IM, Hughes Aircraft Company, Culver City, California, July 1967.

Craig, D. W. and Hershberger, M. L., FLAMR Operator Target/OAP Recognition Study, Hughes Aircraft Company, Culver City, California, Report No. P74-501, December 1974.

Hershberger, M. L. and Carel, W. L., Target Location with High Resolution Radar, AFAL-TR-67-147, August 1967.

Hershberger, M. L. and Craig, D. W., Synthetic Array Radar Operator Performance: Research Study and Simulation, AFAL-TR-71-279, March 1972.

Hershberger, M. L. and Craig, D. W., Synthetic Array Radar Utilization and Display, AFAL-TR-69-397, April 1970.

Hughes Aircraft Company, Comparison of F-15/F-105/F-106 Weapon System Operations. 9 May 1969.

ter Braak, F., "High Workload Tasks of Aircrew in the Tactical Strike, Attack and Reconnaissance Roles," Simulation and Study of High Workload Operations. AGARD Conference Proceedings No. 146, Oslo, Norway, April 1974. (AD A007963)