

C.P. No. 1374

AD A 041718

C.P. No. 1374



*Handwritten initials*  
*2*

PROCUREMENT EXECUTIVE, MINISTRY OF DEFENCE

AERONAUTICAL RESEARCH COUNCIL

CURRENT PAPERS

A Study of Local Stress Histories in  
Loaded and Unloaded Holes and their  
Implications to Fatigue Life Estimation

by

J. E. Moon

B. H. E. Perrett

P. R. Edwards

Structures Dept., R.A.E., Farnborough Hants.

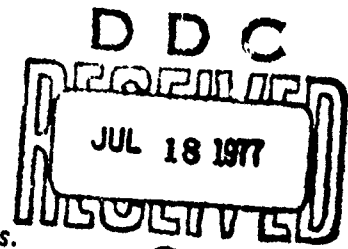

*Handwritten initials*

AD NO. \_\_\_\_\_  
DDC FILE COPY

LONDON: HER MAJESTY'S STATIONERY OFFICE

1977

~~£2.00 NET~~

HER MAJESTY'S STATIONERY OFFICE  
Approved for public release;  
Distribution Unlimited

EARC-CP

\*CP No. 1374

11 July 1975

(12371)

191,000 1 1-1 1-2

A STUDY OF LOCAL STRESS HISTORIES IN LOADED AND UNLOADED HOLES AND THEIR IMPLICATIONS TO FATIGUE LIFE ESTIMATION,

by

10 J. E./Moon,  
B. H. E./Perrett  
P. R./Edwards

SUMMARY

This Report presents local stress measurements in aluminium alloy specimens at open holes and pin-loaded holes of the same elastic stress concentration factor, under variable amplitude loading. The Companion Specimen Method was used and the results are interpreted with particular reference to fatigue life estimation. In addition the Neuber Test and Linear Strain Methods were used to make estimates of the local stress history for the case of the open hole.

Companion Specimen Tests with an ascending-descending zero to peak stress sequence showed that there was no significant difference in local stress ranges or residual stresses between an open hole and a pin-loaded hole of the same stress concentration. A comparable Neuber Test produced errors in both maximum local strains and residual stresses and ways of improving this method are discussed. The Linear Strain Method in the form currently suggested by ESDU made poor estimates of residual stresses.

*The substance of this paper was presented under the title "A Study of Local Stress Histories in Structural Elements and their Implications to Fatigue Life Estimates", at the SEE Fatigue Group international conference on Fatigue Testing and Design held at City University, London in April 1976.*

CONTENTS

	<u>Page</u>
1 INTRODUCTION	3
2 DETERMINATION OF THE LOCAL STRESS HISTORIES AT AN OPEN HOLE AND A PIN-LOADED HOLE OF THE SAME ELASTIC STRESS CONCENTRATION FACTOR	3
2.1 Method of measurement	4
2.2 Specimens and material	4
2.3 Summary of tests	4
2.4 Results and discussion	4
3 EVALUATION OF A NEUBER TEST PREDICTION OF LOCAL STRESS HISTORY AT THE OPEN HOLE	6
3.1 Specimens and material	6
3.2 Summary of tests	6
3.3 Results and discussion	7
4 LINEAR STRAIN METHOD PREDICTIONS OF LOCAL STRESS HISTORY AT THE OPEN HOLE	9
4.1 Predictions	9
4.2 Results and discussion	10
5 CONCLUSIONS	10
Appendix A Neuber's Rule and its application to a Neuber Test	13
Appendix B An example of how errors can arise when Neuber's Rule is applied to a sequence of loads	15
Appendix C The Linear Strain Method of predicting values of residual stresses formed by peak loads	17
Symbols	18
References	18
Illustrations	Figures 1-15

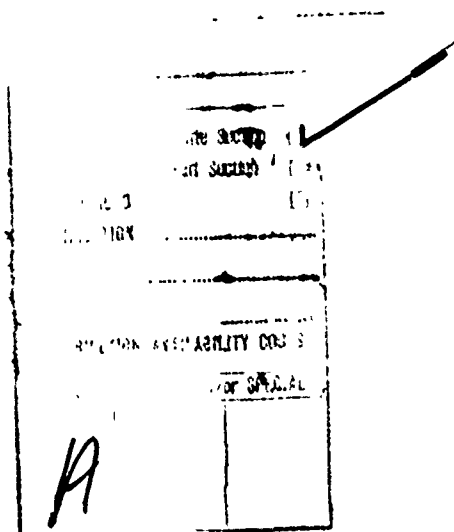

## 1 INTRODUCTION

Although Miner's rule is used extensively in the aircraft and other industries for fatigue life prediction it is well known that it can lead to errors<sup>1</sup>. In many cases these errors can be reduced by considering the actual state of stress at the point of fatigue initiation, rather than average net section stresses. An example of this is the case where the extreme loads in a spectrum cause local yielding at a point of stress concentration. Depending on whether the yielding is tensile or compressive, the residual stresses produced will be compressive or tensile respectively. These alter the mean stress at the point of maximum stress and this in turn affects the fatigue performance of the component and hence the accuracy of Miner's Rule used with nominal stress histories. In order to improve methods of life prediction, local stress histories at simple stress concentrations are commonly studied by the Companion Specimen and Neuber Test Methods.

Section 2 describes Companion Specimen Tests<sup>2</sup> of an open hole and a pin-loaded hole of the same elastic stress concentration factor to investigate any differences in local stress history which might affect the fatigue performance.

Section 3 describes the next stage of the work where a Neuber Test<sup>3</sup> was carried out on a plain specimen to reproduce the conditions at the open hole studied in section 2. Attempts were made to trace the source of inaccuracy in the Neuber Tests and modifications to the basic concept were examined.

The Linear Strain Method is commonly used in the aircraft industry during life prediction when making estimates of residual stresses formed in components during spectrum loading. Section 4 presents estimates for the open hole and compares them with the Companion Specimen measurements of section 2.

## 2 DETERMINATION OF LOCAL STRESS HISTORIES AT AN OPEN HOLE AND A PIN-LOADED HOLE OF THE SAME ELASTIC STRESS CONCENTRATION FACTOR

In recent years a large body of data has been collected on stress histories at open holes, commonly called notches, but very little work has been carried out for the case of the pin-loaded hole. In this investigation the Companion Specimen Method was used to determine the local stress histories in a notch and a pin-loaded hole having the same nominal elastic stress concentration factor, and subjected to the same net stress sequence. The aim of this work was to investigate any differences which might affect the fatigue performance and, in particular, which would be significant when applying a residual-stress correction to life prediction, such as the ESDU rule<sup>4</sup>.

## 2.1 Method of measurement

Briefly, the Companion Specimen Method<sup>2</sup> consists of reproducing on a plain specimen the stress and strain history at a point of stress concentration. A strain gauge is attached at the point of interest in a structural feature, generally where the fatigue crack is likely to start, and the strain history is recorded whilst the specimen is subjected to the desired load sequence. The recorded strain sequence is then applied to a plain specimen, of the same material as the component and, by measuring the loads applied, the corresponding stress history in the component is determined. This method relies on the assumption that there is a uniaxial state of stress at the point of measurement, which is reasonable for an open hole in a relatively thin specimen.

## 2.2 Specimens and material

All specimens were cut from a single bar of DTD 5014 aluminium alloy material. The specimen on which the measurements were carried out is shown in Fig.1. The central open hole and the pin-loaded holes at each end were designed using data sheets<sup>5,6</sup> to have the same elastic stress concentration factor ( $K_t = 2.96$ ) and net section area. Thus both features experienced the same net stress and, in the elastic regime at least, the local stress histories were theoretically identical. The steel loading pins had slots milled along their length to accommodate the strain gauge and associated leads. The companion plain specimen is shown in Fig.2.

## 2.3 Summary of tests

The theoretical value of stress concentration was checked experimentally for both the notch and pin-loaded hole. For the pin-loaded hole the effect on stress concentration factor of pin clearance in the range 0.0001 to 0.0007 of diameter was investigated.

The load sequence applied in the main part of the investigation is shown in Fig.3. It included peaks high enough to cause appreciable local plastic flow. The main criteria used for judging differences in behaviour were the local stress range and the residual stress induced in each cycle. For the purposes of this Report residual stress is defined as that axial stress which would be left at the root of the notch if the external load was removed, provided that the specimen behaved elastically during unloading.

## 2.4 Results and discussion

For the notch the experimentally determined value of  $K_t$  was found to be about 2% lower than in theory. The pin-loaded hole, however, exhibited a

slight nonlinearity of  $K_t$  in the 'elastic' regime, and compared with the notch the elastic stress concentration factor was between 0 and 10% lower, depending on stress range. This fact will be taken into consideration when interpreting later results.

The investigation into the effect of pin clearance showed that, in the range 0.0001 to 0.0007 of diameter there was no perceptible difference in elastic stress concentration factor. In subsequent testing a pin clearance of between 0.0001 and 0.0003 of diameter was used.

Results were obtained from three notches and four pin-loaded holes, and the results presented are based on the average of these.

Fig.4 is a typical example of a graph for a notched specimen, of net stress versus local strain; this particular plot is for a virgin specimen loaded in the ascending part of the sequence, i.e. load changes 1 to 24. The corresponding local stress versus local strain diagram obtained from a plain specimen is shown in Fig.5. For comparison Fig.6 shows a net stress versus local strain diagram obtained from a pin-loaded hole under the same conditions, and Fig.7 is the corresponding local stress versus local strain diagram.

Examination of these and other graphs revealed the following trends:

The maximum strains reached at each peak were greater for the notch than for the pin-loaded hole, being about 26% greater at the maximum peak in the first ascending sequence. This is only partly explained by the observed difference in elastic stress concentration factor.

The hysteresis loops in the net stress versus local strain diagrams were much wider for the notch than for the pin-loaded hole. It is not known what, if any, effect this difference would have on fatigue performance.

The residual stresses following each peak load were approximately the same for both structural features, the difference being generally about 2%. However, this could be expected as the post-yield stress-strain curve of the material used in this investigation was almost horizontal. Had the stress-strain curve been less flat in the plastic region, the difference in strains at each peak noted earlier would be expected to result in a greater difference in residual stresses.

It has already been noted that in the elastic region the stress ranges in the pin-loaded hole were from 0% to 10% lower than in the notch. Following first yield it was observed that differences in stress range were generally reduced.

In summary it may be stated that, for the case considered, there seems to be no significant difference in local stress ranges, from a fatigue damage point of view, between a notch and pin-loaded hole of the same nominal stress concentration factor. Furthermore, again for the case considered, a pin-loaded hole can be treated as an open hole of the same  $K_t$  when applying a residual stress correction to life prediction, such as that suggested by ESDU. However, it was found that the maximum strains formed at each load peak were up to 26% less in the pin-loaded hole than the notch. This effect would be expected to result in a greater difference in residual stresses in the two components if the material concerned had a post-yield stress strain curve which was not so flat.

### 3 EVALUATION OF A NEUBER TEST PREDICTION OF LOCAL STRESS HISTORY AT THE OPEN HOLE

Neuber Testing allows direct simulation on a plain specimen of the local stress history at the root of a notch in a structural component without measurements on the actual specimen. The aim of this programme was to assess how accurately a Neuber Test could reproduce the Companion Specimen local stress measurements determined on the notched component described in the previous section. A secondary objective was to consider what improvements could be made to the Neuber Test used in this work, should errors prove to be unacceptable.

#### 3.1 Specimens and material

The plain specimens used in this work are as shown in Fig.2. They were cut from the same bar of DTD 5014 aluminium alloy as the specimens used in the companion specimen work described in the previous section, thus allowing a direct comparison.

#### 3.2 Summary of tests

Neuber's Rule and the basis of the Neuber Test are described in Appendix A. Briefly, this method relies on an equation which relates the local stress and strain ranges to the net stress range by the stress concentration factor and Young's modulus:

$$\frac{K_t^2 \Delta s^2}{E} = \Delta \epsilon \Delta \sigma \quad (1)$$

Neuber Tests were carried out on plain specimens using the sequence of net stresses shown in Fig.3 which was used in the Companion Specimen Tests of section 2. In order to investigate some of the differences obtained, tests were carried out using a single load up to a large peak value and some simple two step tests were also conducted.

### 3.3 Results and discussion

Fig.8 shows a typical graph of local stress versus local strain produced by a Neuber Test for the first ascending sequence, i.e. load stages 1-24 of Fig.3. This should be compared with Fig.5 which is the corresponding local stress versus local strain diagram obtained from Companion Specimen Testing, the method widely believed to reproduce accurately the local stress-strain history in a notch. It was found that in the Neuber Test the accuracy of simulation varied from cycle to cycle. Fig.9 shows that the maximum strain attained at each load peak was over-estimated by between 3% and 20% whilst Fig.10 shows that the compressive residual stresses following each load peak varied from under-estimation by 17% to over-estimation by 15%.

However it was considered that these errors might be specific to the way in which Neuber's Rule works when applied to this type of load sequence. Accordingly an investigation was made of the values obtained by the Companion Specimen and Neuber Methods for a single application of load up to a peak net stress instead of for an ascending sequence up to the same peak. Tests were carried out using first a stress change 0-300MN/m<sup>2</sup> and secondly the sequence of Fig.3 up to the net stress change 0-300MN/m<sup>2</sup>. Whereas the Companion Specimen Method produced local strains after the two loadings which were within 5.4% of each other, the Neuber testing predicted that the final local strains after the two loadings would differ by 17%.

Appendix B describes the way in which Neuber's Rule can lead to differences in local stress-strain history simulation, when applied to the type of sequence employed in this Report. It shows that Neuber's Rule applied to an idealised stress-strain curve will predict a different value of local stress and strain after a net stress change of 0-325MN/m<sup>2</sup> from those obtained after the sequence 0-200-0-325MN/m<sup>2</sup>. However, the Companion Specimen Method showed that after the two loadings the local strains were within 2.9% and the local stresses within 0.3%.

#### 3.3.1 Sequence broken down into individual half cycles

To further investigate the performance of Neuber's Rule, theoretical estimates were made of local stress and strain for each zero to peak half cycle in Fig.3, as if each one started with a virgin specimen.

Using equation (1) the Neuber constant was calculated for each zero to peak half cycle. This allowed the hyperbola for each stress range to be plotted

on the material stress-strain diagram as in Fig.11. The point where each hyperbola intersected the actual stress-strain curve gave an estimate of the local stress and strain after each half cycle. The value of  $K_t$  used was 2.96, the elastic stress concentration factor.

The estimates of local strain after each half cycle were compared with those obtained in the Companion Specimen Testing, and the results are plotted in Fig.9. In all cases the maximum local strain at each net stress peak was over-estimated, the greatest error being 37%. It can be seen that these estimates were more inaccurate than those obtained using the Neuber Test on the full sequence.

### 3.3.2 Determination of required $K_f$ to give accurate simulation of local stresses and strains

The over-estimation of local strains discussed above is well known and the factor  $K_t$  is often replaced by the so-called fatigue notch factor  $K_f$ , in order to improve the simulation of local stress-strain history.  $K_f$  generally has a lower value than  $K_t$  and several methods have been proposed for calculating a value of  $K_f$ . For example one method<sup>7</sup> yields a value of  $K_f = 2.516$  for the particular notch used in this Report, whereas another method<sup>8</sup> produces a value of 2.747.

Instead of repeating Neuber Tests using revised values of  $K_f$ , it was decided to calculate the required value of  $K_f$  to give accurate simulation of each individual zero to peak half cycle in the Companion Specimen Results, assuming each half cycle started with a virgin specimen.

Rearranging equation (1), and replacing  $K_t$  by  $K_f$ :

$$K_f^2 = \frac{\Delta\sigma\Delta\epsilon E}{\Delta s^2}$$

$K_f$  was calculated for each zero to peak net stress half cycle. The value of local stress and strain,  $\Delta\epsilon$  and  $\Delta\sigma$ , were those obtained in the Companion Specimen Testing on the notch of  $K_t = 2.96$ .

The results are plotted in Fig.12, which shows the variation required in  $K_f$  versus net stress, in order that Neuber's Rule would accurately reproduce the local stresses and strains at each net stress peak in the sequence. This shows

$K_f$  varying from 2.9 to 2.52, i.e. no consistent value of  $K_f$  was found. A similar variation has been found by other workers<sup>9</sup>.

It was then decided to apply the same technique to obtain the value of  $K_f$  needed to eliminate the errors in Neuber Testing when applied to the full sequence. The required value of  $K_f$  was calculated for each half cycle assuming that a full Neuber Test was carried out on one plain specimen, i.e. that it was cycled through the full sequence of Fig.3. Thus the start of each half cycle was the end of the last half cycle, not the origin of the stress-strain diagram as in the previous calculations. In this case it was found that  $K_f$  for all cycles was  $2.75 \pm 3\%$  compared with values varying from 2.9 to 2.52 for the single cycle case. It is thought probable that the constancy of  $K_f$  for the full sequence was due to the fact that in this sequence the net stress range was increased by equal amounts in successive cycles.

A method has been proposed<sup>10</sup> which seeks to allow for previous loading history by considering what is referred to as 'material memory'. This is done by shifting the origin coordinate points for each cycle as soon as the stress-strain condition returns to the previously interrupted path. In the case of the ascending sequence employed in this Report, when the stress-strain path rejoins the original curve on a zero to peak stress change, the coordinates of the start of the cycle would be shifted back to the origin of the stress strain curve. Thus each zero to peak stress change would be assumed to have started with a virgin specimen. If, however, a peak to zero stress change were interrupted with a small cycle then, on continuing with the main peak to zero cycle, the coordinates of the origin would need to be shifted back to the original peak. This resetting of the origin and necessary storage of previous loading history add a further complication to the Neuber Control computer program. The occurrence of appreciable strain hardening or softening would introduce further difficulties with this method.

#### 4 LINEAR STRAIN METHOD PREDICTIONS OF LOCAL STRESS HISTORY AT THE OPEN HOLE

The Linear Strain Method is commonly used in the aircraft industry during life prediction when estimating residual stresses formed in components during spectrum loading. The method is briefly described in Appendix C.

##### 4.1 Predictions

The method was used to make estimates of:

- (a) local stress and strain at each net stress peak in the sequence shown in Fig.3, assuming each one started with a virgin specimen;
- (b) residual stresses at zero load following each net stress peak, under the same conditions as in (a).

#### 4.2 Results and discussion

The accuracy of prediction was determined by comparison with the Companion Specimen data, and the results of this exercise are plotted in Figs.9 and 10, together with the results of the Neuber Testing.

In the case of the Linear Strain Method it can be seen in Fig.9 that the maximum strain attained at each peak was very much under-estimated; the predictions were up to 40% less than the actual readings. This, and the fact that no allowance was made for the Bauschinger Effect led to the result shown in Fig.10 that the compressive residual stresses at zero load following each load peak were greatly over-estimated. (The Bauschinger Effect is the reduction in compressive yield stress following tensile yield.) Thus the Linear Strain Method in this form as recommended by ESDU<sup>4</sup>, compares poorly with Companion Specimen Testing.

#### 5 CONCLUSIONS

Measurements and predictions have been made by different methods of the local stress histories under variable amplitude loading at open holes and pin-loaded holes with particular reference to fatigue life estimation.

(a) Comparison of an open hole and a pin-loaded hole of the same stress concentration by the Companion Specimen Method for an ascending sequence of zero to peak stress ranges showed no significant difference in local stress ranges or residual stresses. However, the maximum strains were considerably greater at the open hole and differences in residual stress could be expected for a material with a less shallow post-yield stress-strain curve.

(b) A comparable Neuber Test was found to over-estimate maximum strains and give a range of error in residual stresses. It was concluded that for a Neuber Test to give an accurate reproduction of the local stress-strain behaviour in a notch, the factor  $K_t$  should be replaced by a variable factor  $K_f$ , and that it may be necessary to allow for previous loading history.

(c) Estimates of residual stresses by the Linear Strain Method in the form currently suggested by ESDU for life prediction were very inaccurate, mainly

because no allowance was made for the Bauschinger Effect. In addition, if the method were applied to a material with a post-yield stress-strain curve which is far from horizontal, then the over-estimation of compressive residual stresses would be even greater due to the under-estimation of the local stress and strain at the peak load.

Appendix A

NEUBER'S RULE AND ITS APPLICATION TO A NEUBER TEST

Neuber's Rule states that<sup>11</sup>

$$K_t^2 = K_\sigma K_\epsilon$$

or

$$\left( \begin{array}{c} \text{elastic stress} \\ \text{concentration factor} \end{array} \right)^2 = \left( \begin{array}{c} \text{true stress} \\ \text{concentration factor} \end{array} \right) \times \left( \begin{array}{c} \text{true strain} \\ \text{concentration factor} \end{array} \right) .$$

Transferring to stress and strain ranges

$$K_t^2 = \frac{\Delta\sigma}{\Delta s} \frac{\Delta\epsilon}{\Delta e}$$

or

$$\left( \begin{array}{c} \text{elastic stress} \\ \text{concentration factor} \end{array} \right)^2 = \frac{\text{local stress range}}{\text{net stress range}} \times \frac{\text{local strain range}}{\text{net strain range}} .$$

Assuming the net section stress remains elastic

$$\underbrace{\frac{K_t^2 \Delta s^2}{E}} = \Delta\sigma \Delta\epsilon \quad (\text{A-1})$$

Neuber constant

where E = Young's modulus.

The point of intersection of the material's stress-strain curve and one of the hyperbolae described by the above equation defines the local stress and strain at the root of a notch of elastic stress concentration factor  $K_t$ , when the notched component is subject to a net stress range of  $\Delta s$ .

In Neuber Testing a computer is used to input strain demands to an electro-hydraulic testing machine containing a plain specimen and operating under strain control. Either an extensometer or a strain gauge mounted on the specimen is used to provide the strain feedback signal, see Fig.13.

The values of the constants  $K_t$  and E are fed into the computer and for each half cycle the value of net stress applicable to the notched specimen is

also entered; this allows calculation of the Neuber constant for each half cycle. The computer then increments the strain input to the machine and samples the load applied to the plain specimen. From the load the stress is calculated, and when the product of the stress and strain ranges experienced by the plain specimen just exceeds the Neuber constant, the computer stops incrementing the strain demand. At this point the stress and strain in the plain specimen are supposed to be the same as the local stress and strain at the root of the notch in the notched component. The next value of net stress range is now fed into the computer and the process is repeated. Thereby this method allows direct simulation on a plain specimen of the local stress-local strain behaviour at the root of a notch in a structural component without measurements on the actual component.

Appendix B

AN EXAMPLE OF HOW ERRORS CAN ARISE WHEN NEUBER'S RULE  
IS APPLIED TO A SEQUENCE OF LOADS

In this Appendix Neuber's Rule is used to predict the local stress-local strain conditions after two loadings, assuming each one started with a virgin specimen.

For the purpose of illustration the material stress-strain curve is simplified to be elastic-perfectly plastic as in Fig.14.

Test 1 consists of loading a notched specimen of  $K_t = 3$  from a net stress of 0 to  $325\text{MN/m}^2$ .

Using Neuber's Rule

$$\begin{aligned}\Delta\epsilon\Delta\sigma &= \frac{K_t^2 \Delta s^2}{E} \\ &= \frac{3^2 \times 325^2}{76000} .\end{aligned}$$

As local stress reaches yield

$$\Delta\sigma = 500 ;$$

$$\begin{aligned}\text{therefore } \Delta\epsilon &= \frac{3^2 \times 325^2}{76000 \times 500} \\ &= \underline{25016 \text{ microstrain}} - \text{ point A on Fig.14 .}\end{aligned}$$

Test 2 consists of loading the same specimen through the sequence:  
0-200, 200-0, 0-325.

0-200

$$\begin{aligned}\Delta\epsilon &= \frac{3^2 \times 200^2}{76000 \times 500} \\ &= \underline{9474 \text{ microstrain}} - \text{ point B on Fig.14 .}\end{aligned}$$

200-0

$$\Delta\epsilon\Delta\sigma = \frac{3^2 \times (-200)^2}{76000} .$$

Assuming compressive yield stress =  $-500\text{MN/m}^2$ , then it can be shown that local yielding in compression will not occur in this cycle, therefore

$$\Delta\epsilon\Delta\sigma = \Delta\epsilon^2 E$$

hence

$$\begin{aligned} \Delta\epsilon &= \frac{3 \times -200}{76000} \\ &= -7895 \text{ microstrain} . \end{aligned}$$

Therefore local strain =  $(9474 - 7895)$   
 $= \underline{1579 \text{ microstrain}}$  - point C on Fig.14 .

and

$$\begin{aligned} \text{local stress} &= (500 - (76000 \times 0.007895))\text{MN/m}^2 \\ &= \underline{-100\text{MN/m}^2} . \end{aligned}$$

0-325

$$\begin{aligned} \Delta\epsilon &= \frac{3^2 \times 325^2}{76000 \times 600} \\ &= \underline{20847 \text{ microstrain}}$$
 - point D in Fig.14 .

Therefore local strain =  $20847 + 1579$   
 $= \underline{22426 \text{ microstrain}}$  .

Thus the end points of the two sequences differ by 2590 microstrain, i.e. by about 10%. Companion Specimen Tests using these two sequences on the specimens used in section 2 of this Report showed that the final strains were within 2.9%.

Appendix CTHE LINEAR STRAIN METHOD OF PREDICTING VALUES OF  
RESIDUAL STRESSES FORMED BY PEAK LOADS

This method is demonstrated in Fig.15. For a particular peak the local stress and strain is calculated assuming purely elastic behaviour:

$$\left. \begin{aligned} \text{local stress} &= (\text{nominal stress}) \times K_t \\ \text{local strain} &= \frac{\text{local stress}}{\text{Young's modulus}} \end{aligned} \right\} \quad (C-1)$$

These give point A on the diagram. A vertical line is drawn from this point to meet the material stress-strain curve at point B. A line is then drawn through B parallel to the initial elastic loading line such that the stress range satisfies equation (C-1), giving point C; should compressive yielding occur this point is usually assumed to be equal and opposite to the tensile yield. Thus if point C lies beyond this point the residual stress is taken to be the compressive yield stress. This method can be further modified to take account of the Bauschinger Effect.

SYMBOLS

$K_t$	theoretical elastic stress concentration factor
$K_f$	fatigue strength reduction factor or notch factor
$K_\sigma$	actual stress concentration factor
$K_\epsilon$	actual strain concentration factor
$\Delta s$	net stress range
$\Delta e$	net strain range
$\Delta \sigma$	local stress range
$\Delta \epsilon$	local strain range
E	Young's Modulus of elasticity

REFERENCES

- | <u>No.</u> | <u>Author</u>                                | <u>Title, etc.</u>  |
|------------|--|---|
| 1          | P.R. Edwards                                 | Cumulative damage in fatigue with particular reference to the effects of residual stresses.<br>ARC Current Paper 1185 (1971)  |
| 2          | J.H. Crews Jr.<br>H.F. Hardrath              | A study of cyclic plastic stresses at a notch root.<br>Exp. Mechanics 23, pp.313-320 (1966)   |
| 3          | S.J. Stadnick<br>Jo Dean Morrow              | Techniques for smooth specimen simulation of the fatigue behaviour of notched members.<br>Testing for prediction of material performance in structures and composites.<br>ASTM STP 515, pp.229-252 (1972)                         |
| 4          | -  | Cumulative fatigue damage calculations (effect of correcting mean stress at stress concentrations).<br>Data sheets on fatigue No.71028, Engineering Science Data Unit, Royal Aeronautical Society (1971)                          |
| 5          | -  | Elastic stress concentration factors. Geometric discontinuities in flat bars or strips of isotropic materials.<br>Data sheets on stress concentrations No.69020. Engineering Science Data Unit, Royal Aeronautical Society (1969) |
| 6          | -  | Stress concentration data.<br>Data sheets on stress concentrations No.65004. Engineering Science Data Unit, Royal Aeronautical Society (1965)   |
| 7          | P. Kuhn                                      | Notch effects on fatigue and static strength.<br>Symposium on aeronautical fatigue sponsored by ICAF and Structures and Materials Panel of AGARD, Rome, April 1963  |
| 8          | T.H. Topper<br>Jo Dean Morrow<br>R.M. Wetzel | Neuber's Rule applied to fatigue of notched specimens.<br>US Naval and Engineering Centre, Aeronautical Structures Laboratory, Report NAEL-ASL-114, June 1967   |
| 9          | A. Conle<br>U. Schulz<br>H. Nowack           | A numerical method for fatigue life prediction.<br>Proceedings of Conference on dimensioning and strength calculations and Congress on material testing, Budapest 28 October 1974 to 1 November 1974                              |

REFERENCES (concluded)

- | <u>No.</u> | <u>Author</u>                                | <u>Title, etc.</u>  |
|------------|--|---|
| 10         | D. Hanschmann<br>K.H. Trautmann<br>H. Nowack | Fatigue behaviour of notched components as evaluated by the Companion Specimen Method and the Neuber Control concept.<br><br>International Conference 'Fatigue testing and design',<br>SEE Fatigue Group, City University, London, England,<br>April 1976 |
| 11         | H. Neuber                                    | Theory of stress concentration for shear strained prismatical bodies with arbitrary nonlinear stress-strain law.<br><br>Trans. ASME, J. of Appl. Mech., pp.544-550 (1961)   |

$K_T$  of notch and pin-loaded hole = 2.96

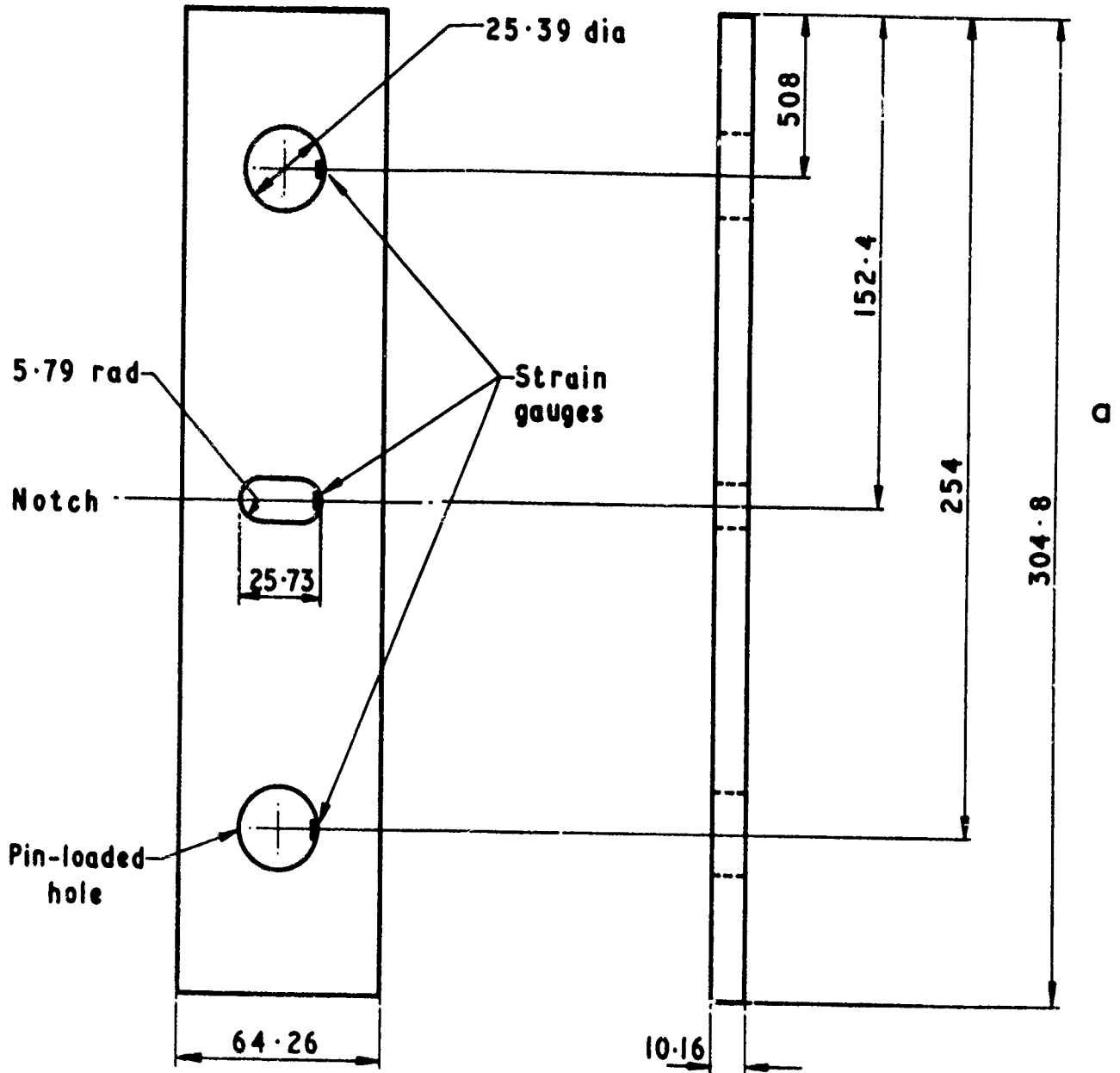

Material - DTD 5014

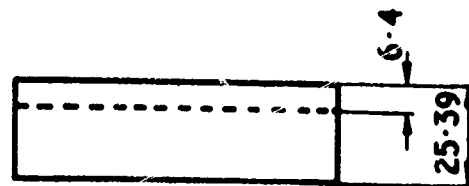
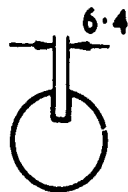

Scale: 1/2

Material: S80

Nominal dimensions in mm

Fig.1 a & b Pin loaded/notched specimen and loading pin

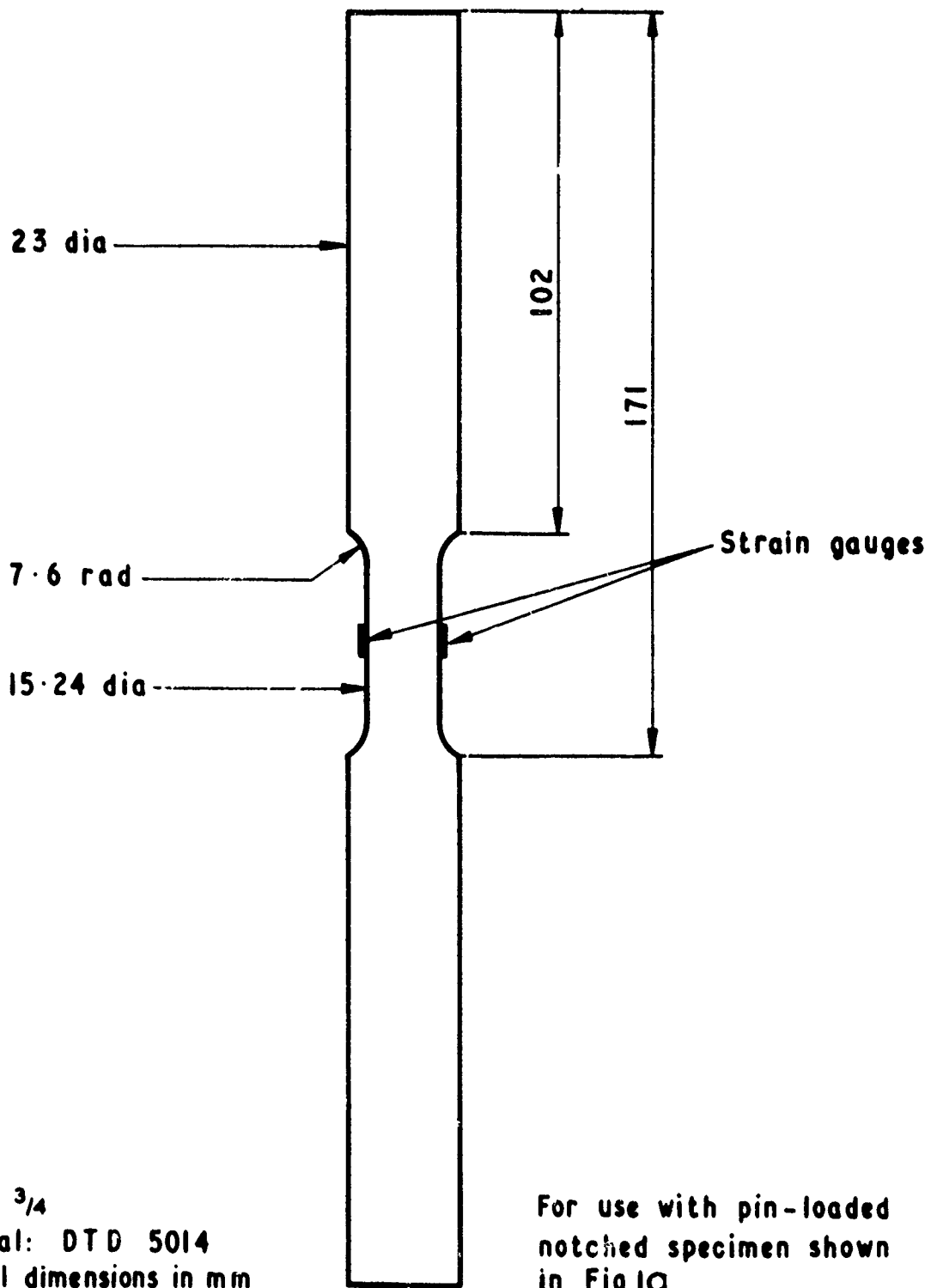

Fig. 2 Plain specimen

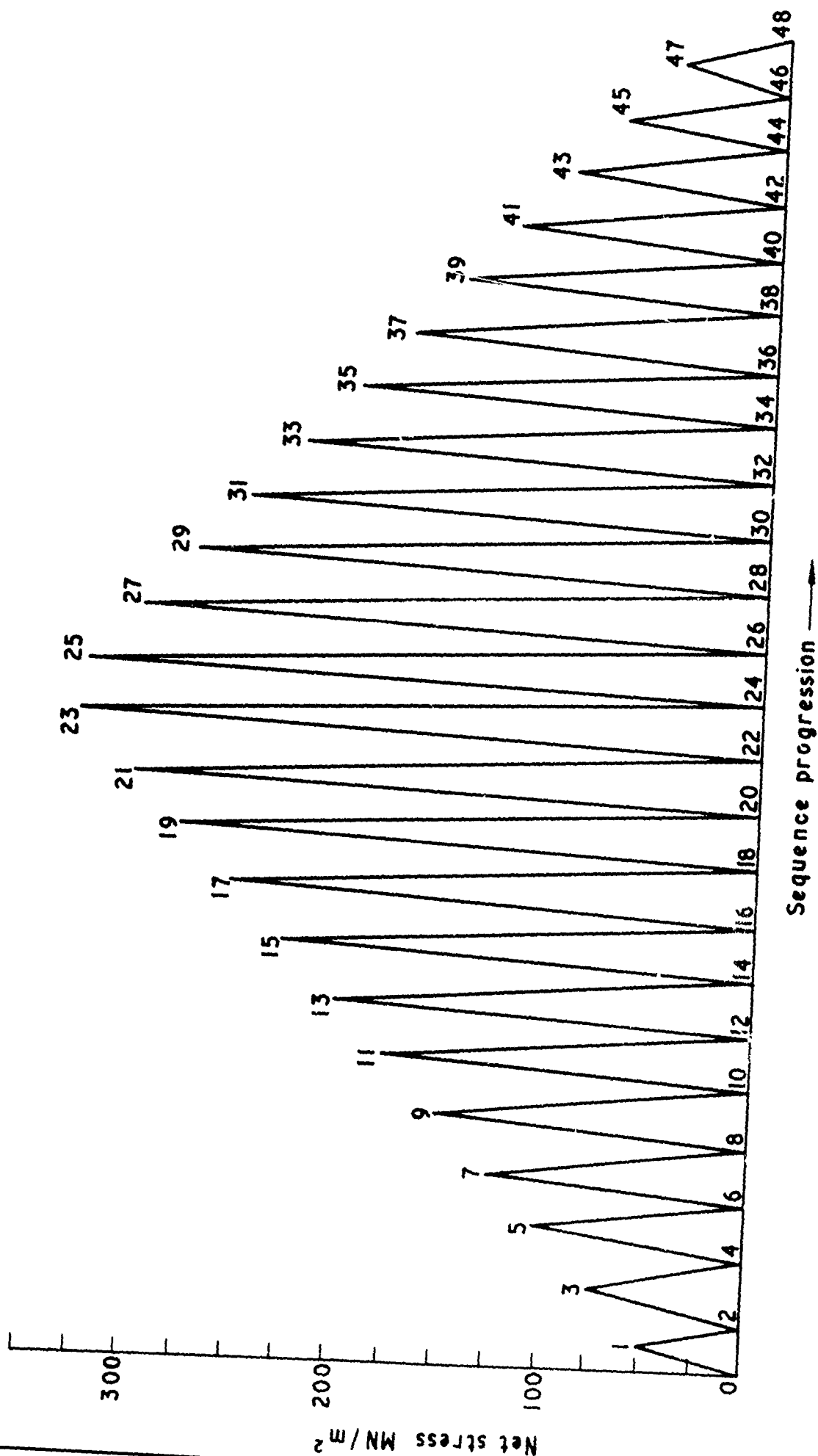

Fig.3 Load sequence applied to pin-jointed notched specimen

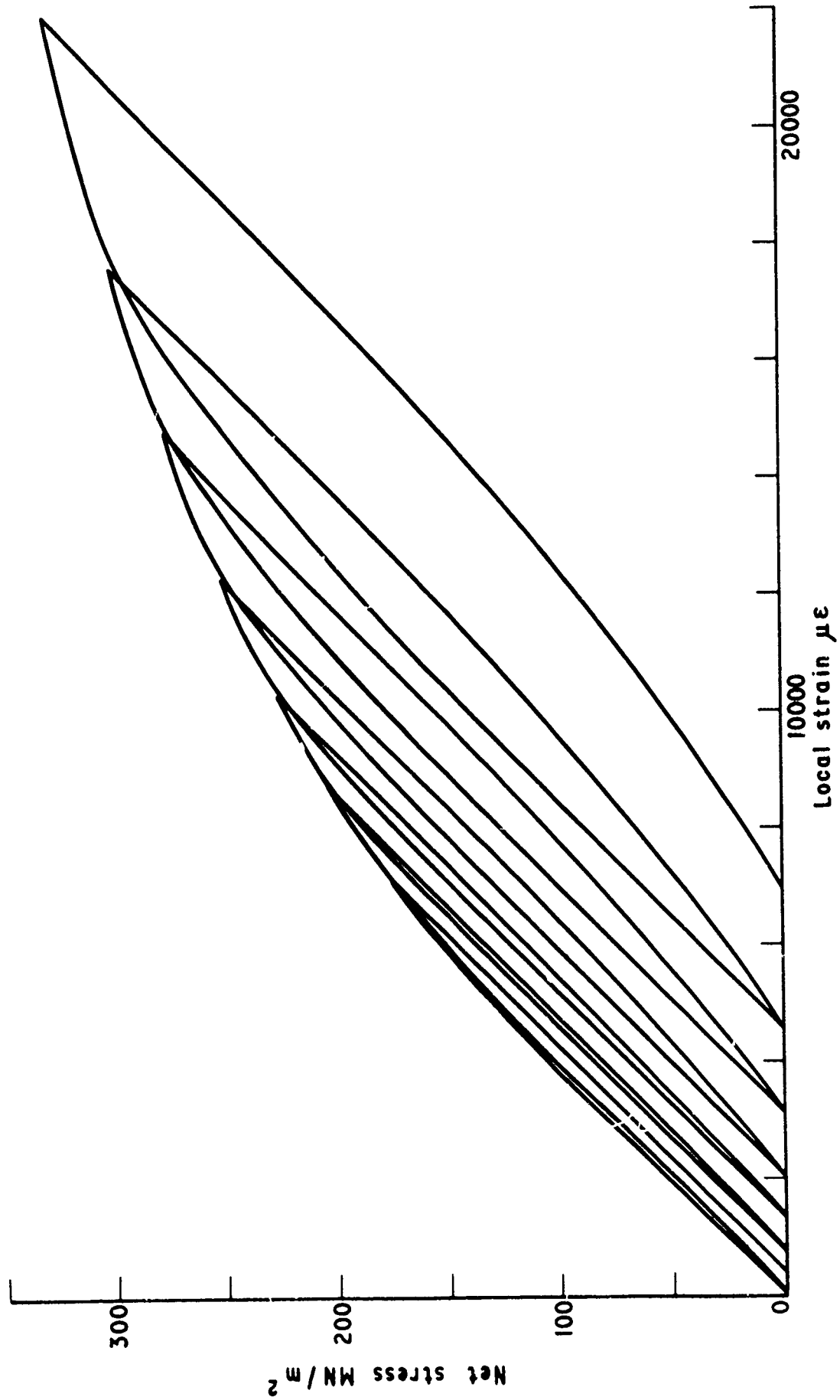

Fig. 4 Net stress vs local strain diagram for notch  $K_T = 2.96$  cycles 1-24

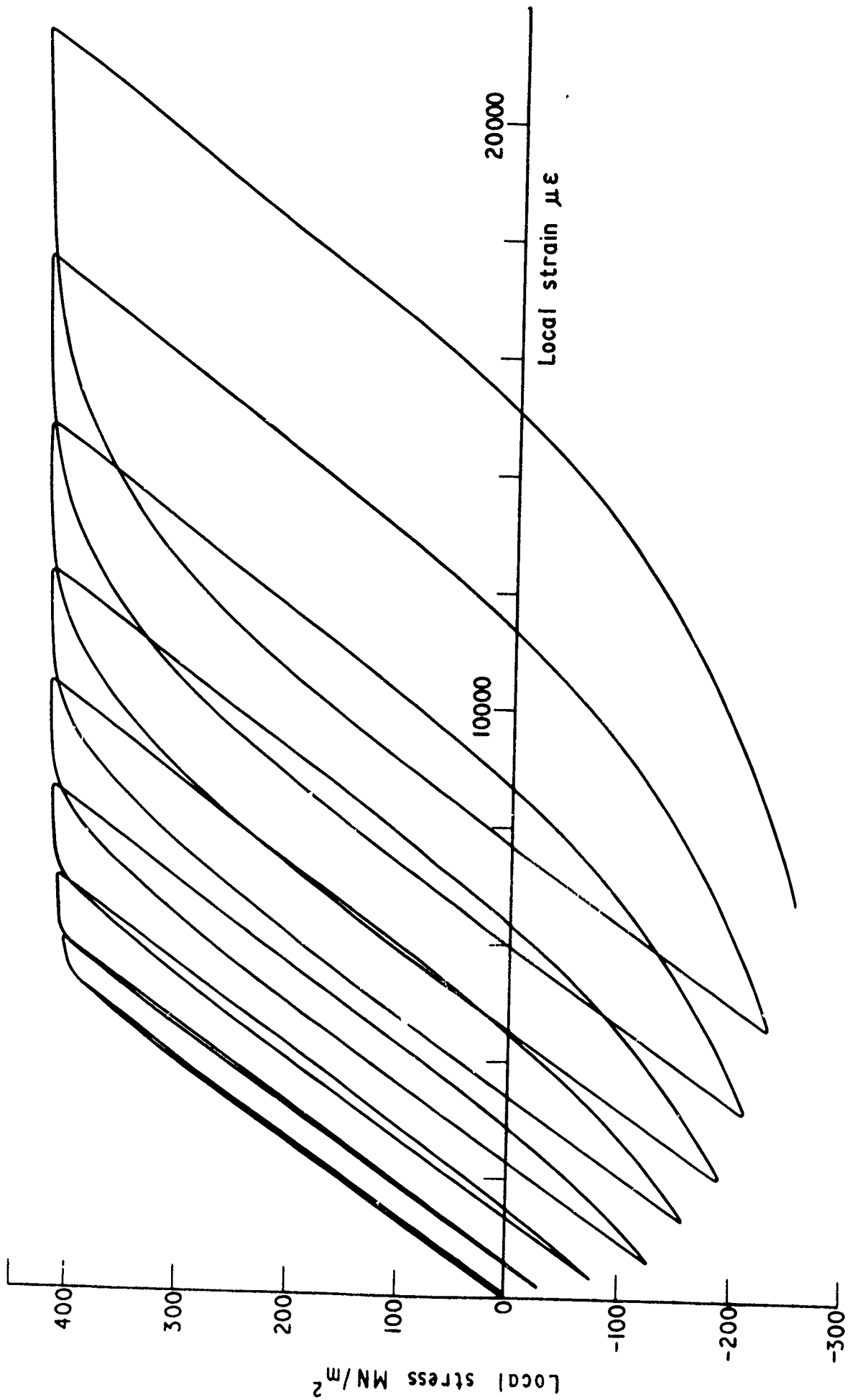

Fig.5 Companion plain specimen reproduction of local stress vs local strain in a notch  $K_T = 2.96$  cycles 1-24

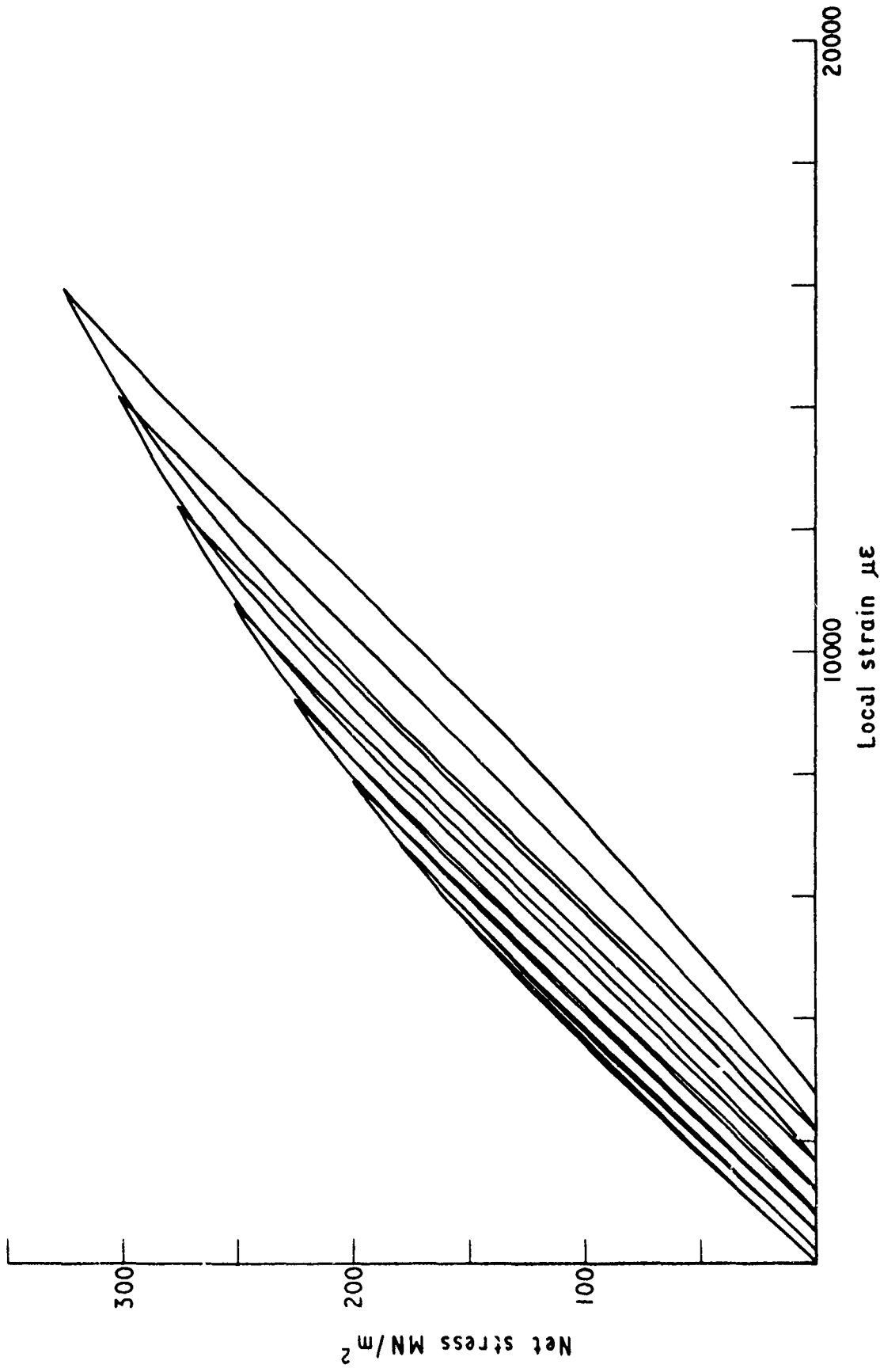

Fig.6 Net stress vs local strain diagram for pin-loaded hole  $K_T=2.96$  cycles 1-24

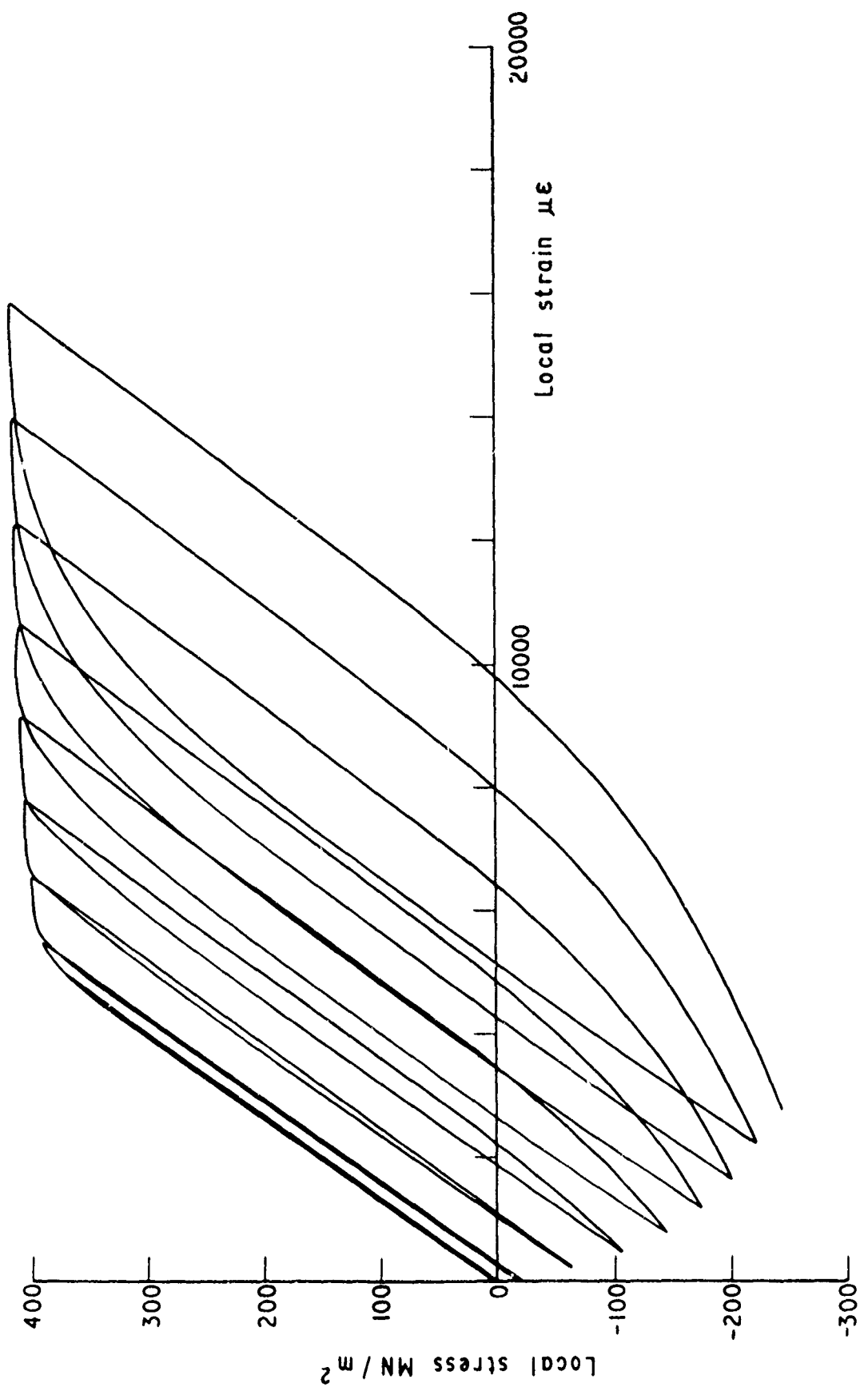

Fig.7 Companion plain specimen reproduction of local stress vs local strain in a pin-loaded hole  $K_T = 2.96$  cycles 1-24

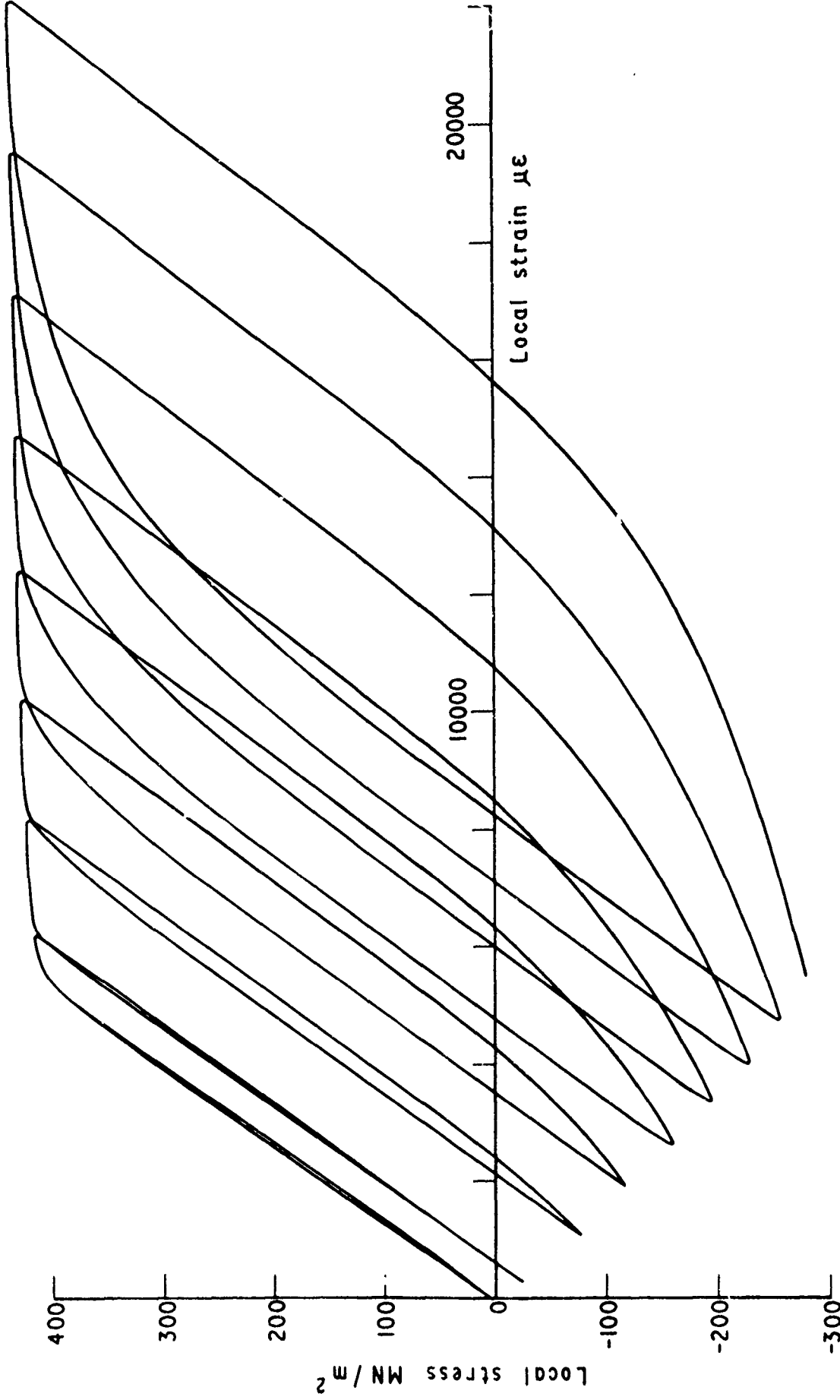

Fig.8 Neuber test on plain specimen using cycles 1-24 of full sequence

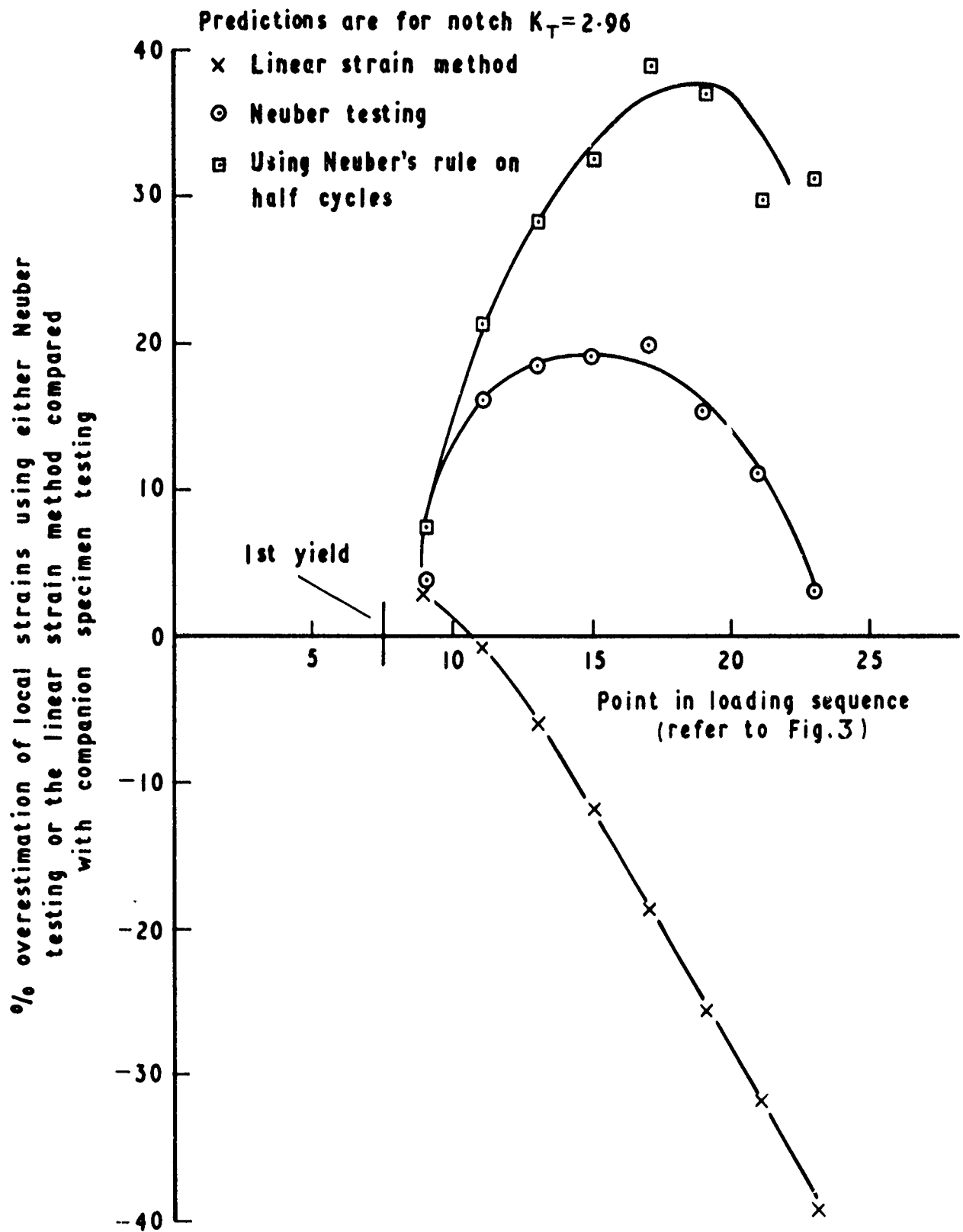

Fig.9 % error in using linear strain method and Neuber testing to predict local strains at net stress peaks

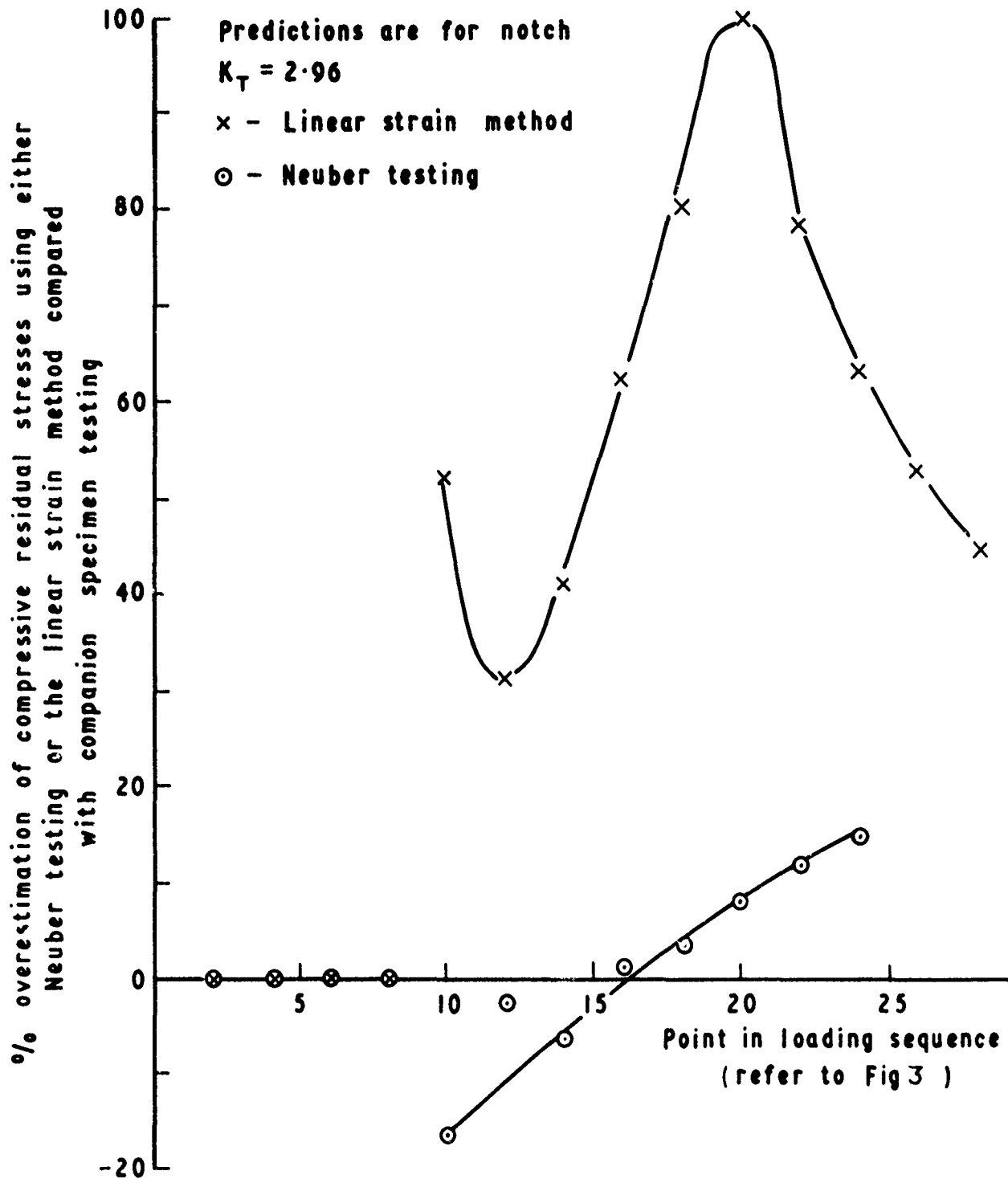

Fig.10 % error in using linear strain method and Neuber testing to predict residual stresses following net stress peaks

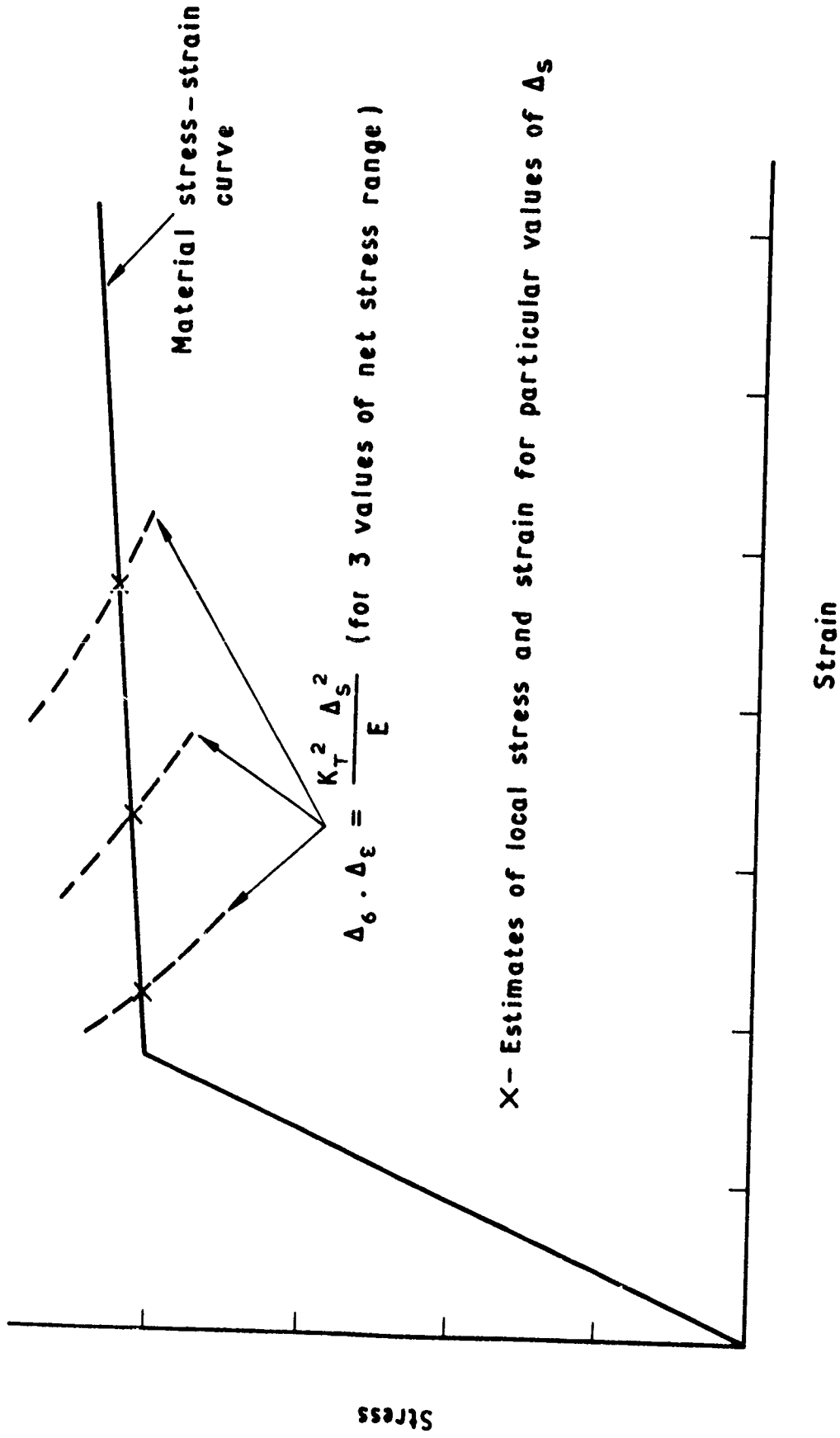
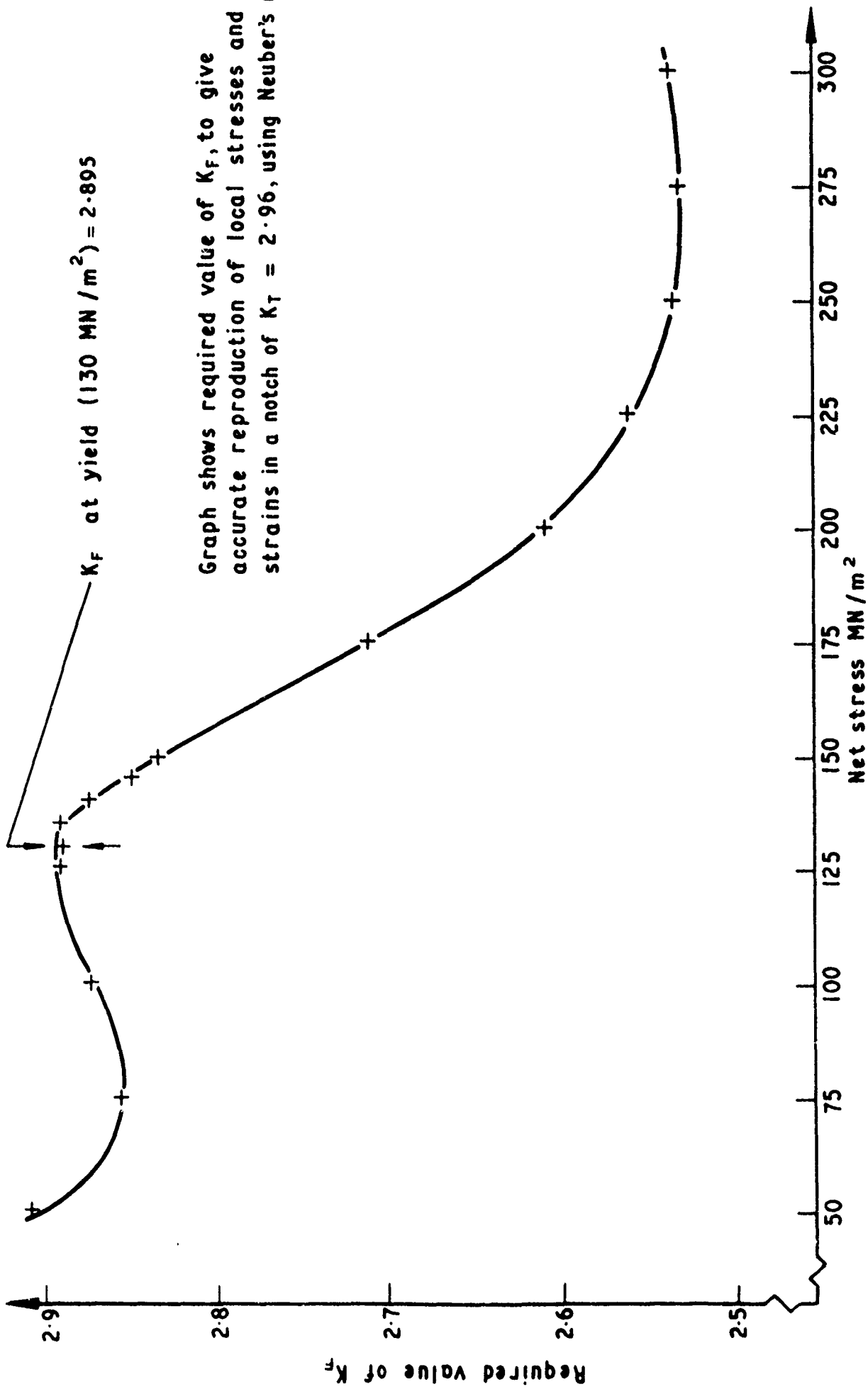
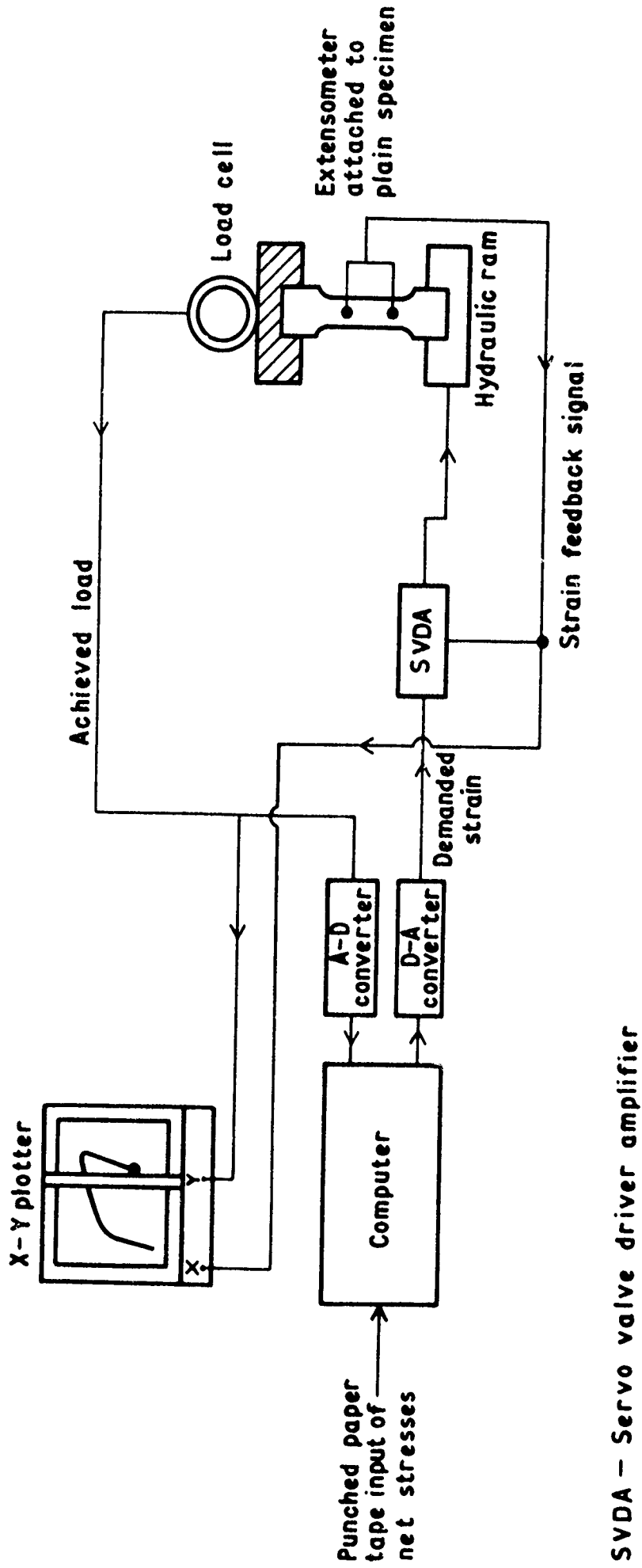

Fig. 11 Example of application of Neuber's rule to individual half cycles



Graph shows required value of  $K_F$ , to give accurate reproduction of local stresses and strains in a notch of  $K_T = 2.96$ , using Neuber's rule

Fig 12 Variation of required  $K_F$  with net stress



SVDA - Servo valve driver amplifier

Fig.13 Schematic diagram of test equipment used in Neuber test

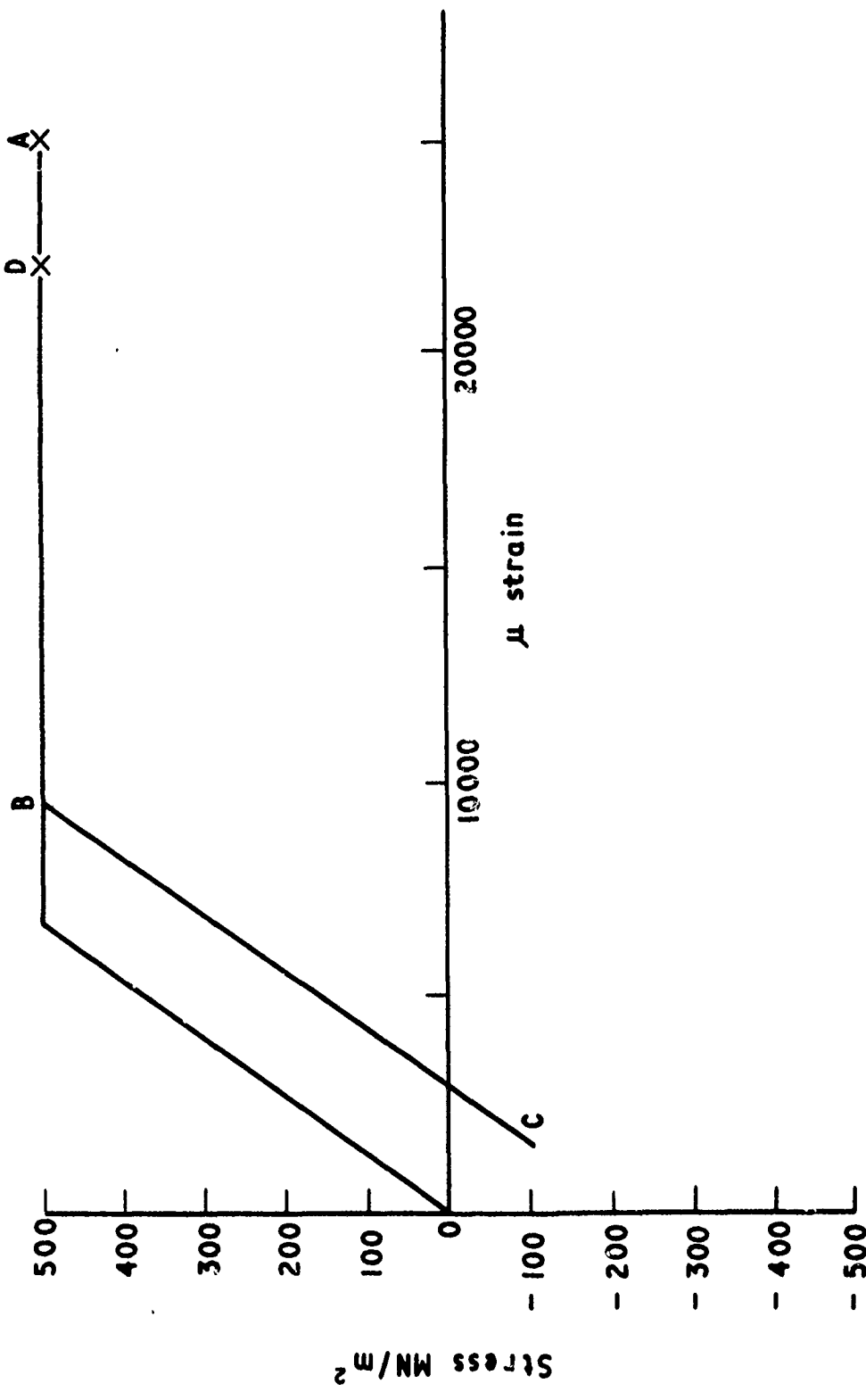

Fig.14 An example of the application of Neuber's rule

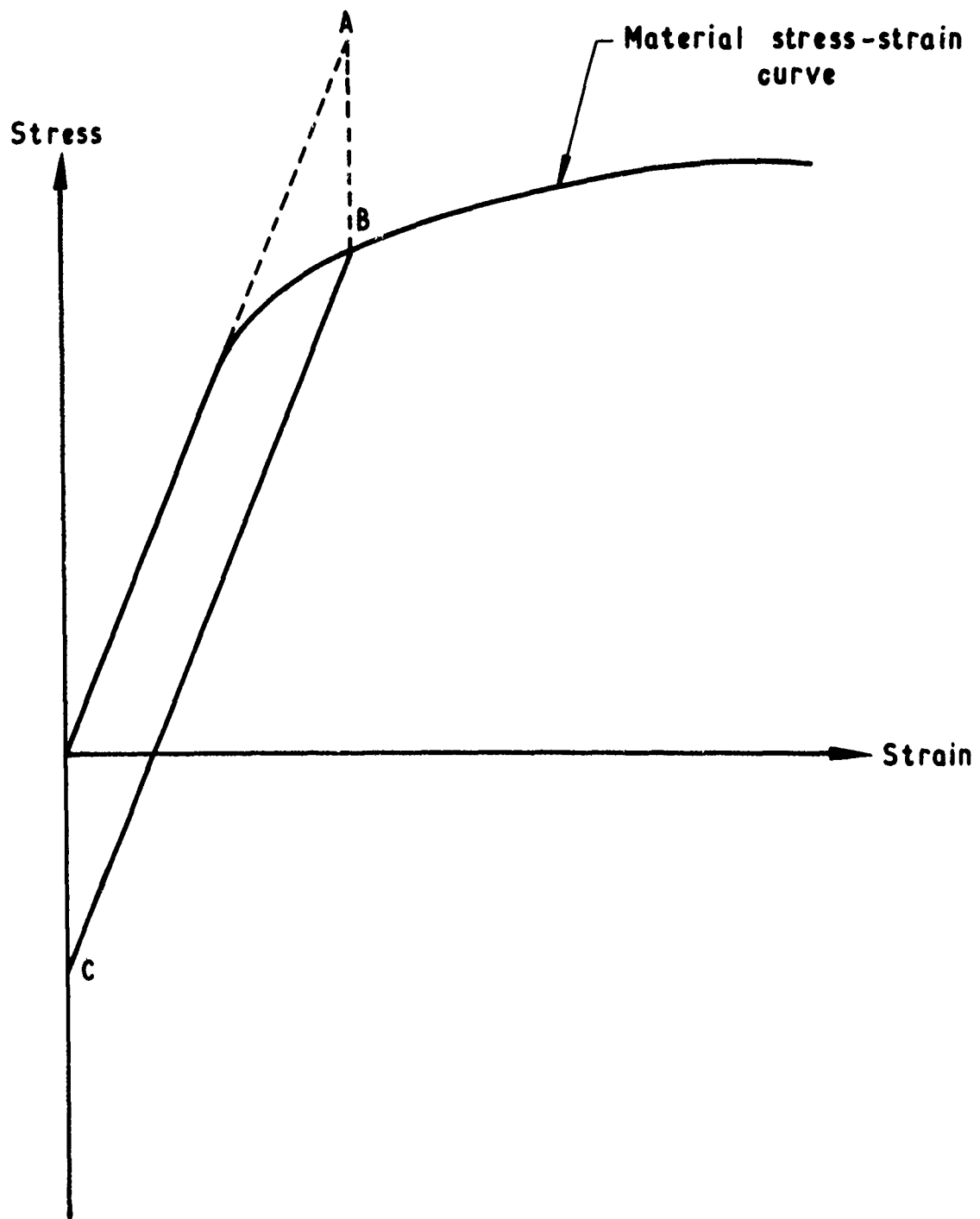

Fig.15 The linear strain method

ARC CP No. 1374  
July 1976

Moon, J. E.  
Perrett, B.H.E.  
Edwards, P.R.

#### A STUDY OF LOCAL STRESS HISTORIES IN LOADED AND UNLOADED HOLES AND THEIR IMPLICATIONS TO FATIGUE LIFE ESTIMATION

This Report presents local stress measurements in aluminium alloy specimens at open holes and pin-loaded holes of the same elastic stress concentration factor, under variable amplitude loading. The Companion Specimen Method was used and the results are interpreted with particular reference to fatigue life estimation. In addition the Neuber Test and Linear Strain Methods were used to make estimates of the local stress history for the case of the open hole.

Companion Specimen Tests with an ascending-descending zero to peak stress sequence showed that there was no significant difference in local stress ranges or residual stresses between an open hole and a pin-loaded hole of the same stress concentration. A comparable Neuber Test produced errors in both maximum local strains and residual stresses and ways of improving this method are discussed. The Linear Strain Method in the form currently suggested by ESDU made poor estimates of residual stresses.

ARC CP No. 1374  
July 1976

Moon, J. E.  
Perrett, B.H.E.  
Edwards, P.R.

#### A STUDY OF LOCAL STRESS HISTORIES IN LOADED AND UNLOADED HOLES AND THEIR IMPLICATIONS TO FATIGUE LIFE ESTIMATION

This Report presents local stress measurements in aluminium alloy specimens at open holes and pin-loaded holes of the same elastic stress concentration factor, under variable amplitude loading. The Companion Specimen Method was used and the results are interpreted with particular reference to fatigue life estimation. In addition the Neuber Test and Linear Strain Methods were used to make estimates of the local stress history for the case of the open hole.

Companion Specimen Tests with an ascending-descending zero to peak stress sequence showed that there was no significant difference in local stress ranges or residual stresses between an open hole and a pin-loaded hole of the same stress concentration. A comparable Neuber Test produced errors in both maximum local strains and residual stresses and ways of improving this method are discussed. The Linear Strain Method in the form currently suggested by ESDU made poor estimates of residual stresses.

ARC CP No. 1374  
July 1976

Moon, J. E.  
Perrett, B.H.E.  
Edwards, P.R.

#### A STUDY OF LOCAL STRESS HISTORIES IN LOADED AND UNLOADED HOLES AND THEIR IMPLICATIONS TO FATIGUE LIFE ESTIMATION

This Report presents local stress measurements in aluminium alloy specimens at open holes and pin-loaded holes of the same elastic stress concentration factor, under variable amplitude loading. The Companion Specimen Method was used and the results are interpreted with particular reference to fatigue life estimation. In addition the Neuber Test and Linear Strain Methods were used to make estimates of the local stress history for the case of the open hole.

Companion Specimen Tests with an ascending-descending zero to peak stress sequence showed that there was no significant difference in local stress ranges or residual stresses between an open hole and a pin-loaded hole of the same stress concentration. A comparable Neuber Test produced errors in both maximum local strains and residual stresses and ways of improving this method are discussed. The Linear Strain Method in the form currently suggested by ESDU made poor estimates of residual stresses.

ARC CP No. 1374  
July 1976

Moon, J. E.  
Perrett, B.H.E.  
Edwards, P.R.

#### A STUDY OF LOCAL STRESS HISTORIES IN LOADED AND UNLOADED HOLES AND THEIR IMPLICATIONS TO FATIGUE LIFE ESTIMATION

This Report presents local stress measurements in aluminium alloy specimens at open holes and pin-loaded holes of the same elastic stress concentration factor, under variable amplitude loading. The Companion Specimen Method was used and the results are interpreted with particular reference to fatigue life estimation. In addition the Neuber Test and Linear Strain Methods were used to make estimates of the local stress history for the case of the open hole.

Companion Specimen Tests with an ascending-descending zero to peak stress sequence showed that there was no significant difference in local stress ranges or residual stresses between an open hole and a pin-loaded hole of the same stress concentration. A comparable Neuber Test produced errors in both maximum local strains and residual stresses and ways of improving this method are discussed. The Linear Strain Method in the form currently suggested by ESDU made poor estimates of residual stresses.

539.4.013.3  
539.431  
669.715

Cut here

539.4.013.3  
539.431  
669.715

DETACHABLE ABSTRACT CARDS

DETACHABLE ABSTRACT CARDS

Cut here

C.P. No. 1374

© Crown copyright

1977

Published by  
HER MAJESTY'S STATIONERY OFFICE

*Government Bookshops*

49 High Holborn, London WC1V 6HB  
13a Castle Street, Edinburgh EH2 3AK  
41 The Hayes, Cardiff CF1 1JW  
Brazennose Street, Manchester M60 8AS  
Southey House, Wine Street, Bristol BS1 2BQ  
258 Broad Street, Birmingham B1 2HE  
80 Chichester Street, Belfast BT1 4JY

*Government Publications are also available  
through booksellers*

C.P. No. 1374

ISBN 011 471120 8