

AD-A041 725

AEROJET LIQUID ROCKET CO SACRAMENTO CALIF
ARIES KICK STAGE.(U)
JUN 77 R G STARKE

F/G 22/2

N00014-71-C-0101

UNCLASSIFIED

NL

| OF |

AD
A041725

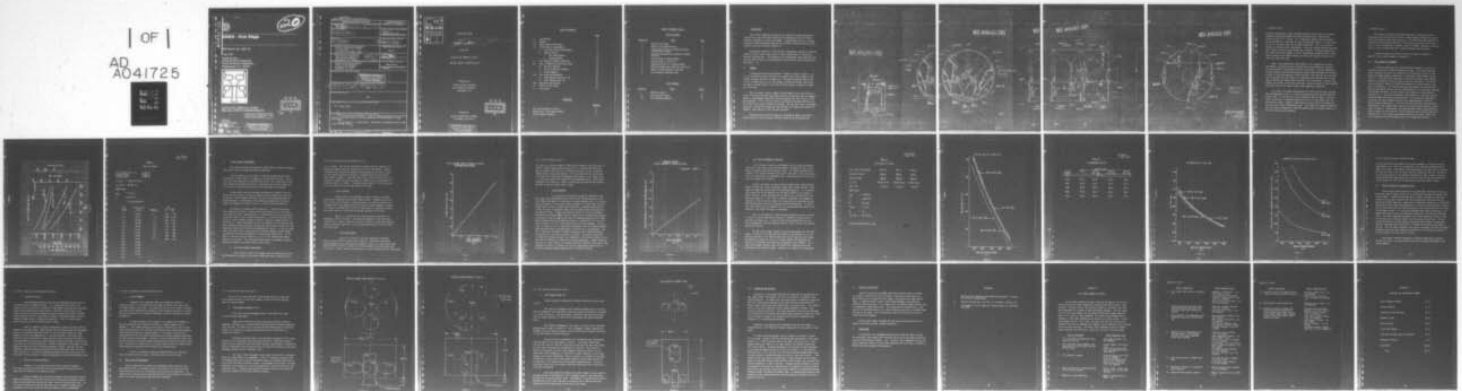

END

DATE
FILMED
8-77

ADA 041725



20
B. S.

ARIES - Kick Stage

NRL-Report No. 3001-13

June 1977

Prepared For:
Office of Naval Research
Naval Research Laboratory
Washington, D.C. 20375

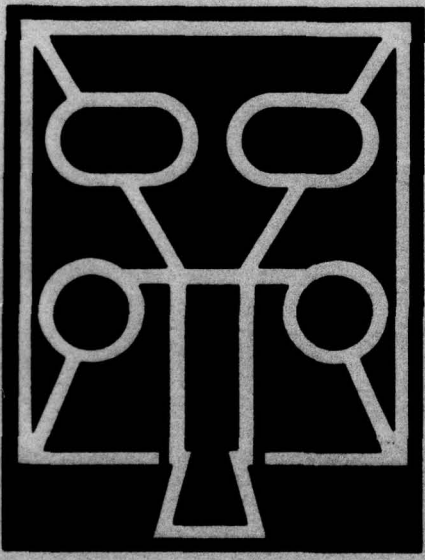

Contract No. N00014-71-C-0101
NRL Req. 000173-1-006170/9-28-70

DDC
RECEIVED
JUL 19 1977
D

REPRODUCTION IN WHOLE OR IN PART
IS PERMITTED FOR ANY PURPOSE OF THE
UNITED STATES GOVERNMENT.

Aerojet
Liquid Rocket
Company
AD No. _____
DDC FILE COPY

DISTRIBUTION STATEMENT A
Approved for public release;
Distribution Unlimited

UNCLASSIFIED

SECURITY CLASSIFICATION OF THIS PAGE (When Data Entered)

REPORT DOCUMENTATION PAGE		READ INSTRUCTIONS BEFORE COMPLETING FORM
1. REPORT NUMBER NRL 3001R-13 ✓ set p.	2. GOVT ACCESSION NO.	3. RECIPIENT'S CATALOG NUMBER
4. TITLE (and Subtitle) 6 ARIES Kick Stage.		5. TYPE OF REPORT & PERIOD COVERED Technical (February-May 1977)
7. AUTHOR(s) 10 R. G./Starke		6. PERFORMING ORG. REPORT NUMBER
9. PERFORMING ORGANIZATION NAME AND ADDRESS Aerojet Liquid Rocket Company P.O. Box 13222 Sacramento, California 95813		8. CONTRACT OR GRANT NUMBER(s) 15 N00014-71-C-0101 haw
11. CONTROLLING OFFICE NAME AND ADDRESS Naval Research Laboratory 4555 Overlook Avenue, S.W. Washington, D.C. 20375 12 42 p.		10. PROGRAM ELEMENT, PROJECT, TASK AREA & WORK UNIT NUMBERS 3001-67
14. MONITORING AGENCY NAME & ADDRESS (if different from Controlling Office) Procuring Contracting Officer Office of Naval Research Department of the Navy Arlington, VA 22217		12. REPORT DATE 11 Jun 77
		13. NUMBER OF PAGES 37
		15. SECURITY CLASS. (of this report) UNCLASSIFIED
16. DISTRIBUTION STATEMENT (of this Report) DISTRIBUTION STATEMENT A Approved for public release; Distribution Unlimited		15a. DECLASSIFICATION/DOWNGRADING SCHEDULE
17. DISTRIBUTION STATEMENT (of the abstract entered in Block 20, if different from Report) 9 Technical rept. Feb-May 77, N/A		
18. SUPPLEMENTARY NOTES N/A		
19. KEY WORDS (Continue on reverse side if necessary and identify by block number) Kick Stage, ARIES		
20. ABSTRACT (Continue on reverse side if necessary and identify by block number) The kick stage was designed as a means of separating contamination-sensitive payloads from ARIES vehicles to allow experiments to be performed in a clean environment. The kick stage is a liquid rocket - essentially a shortened version of the proven Aerobee family		

ACCESSION for		
NYIS	White Section	<input checked="" type="checkbox"/>
CDC	Buff Section	<input type="checkbox"/>
UNANNOUNCED		<input type="checkbox"/>
JUSTIFICATION		
Per Hrs. on file		
BY		
DISTRIBUTION/AVAILABILITY CODES		
Dist.	AVAIL. and/or	SPECIAL
A		

ARIES KICK STAGE

per Telecom w/ NRL - TID Dred Sec
OK/TED 25 Jul 77
~~NRL Report No. 0001R-13~~

June 1977

Contract No. N00014-71-C-0101

NRL Req. 000173-1-006170/9-28-70

Prepared for
 Office of Naval Research
 Naval Research Laboratory
 Washington, D.C.

D D C
 RECEIVED
 JUL 19 1977
 RECEIVED
 D

Prepared by
 Aerojet Liquid Rocket Company
 Sacramento, California

DISTRIBUTION STATEMENT A
 Approved for public release;
 Distribution Unlimited

TABLE OF CONTENTS

	<u>Page</u>
I. Introduction	1
II. Summary	1
III. ARIES Nominal Performance	4
IV. Flight Control Requirements	7
A. Kick Stage Thrust Misalignment	7
B. Vehicle Balance	8
1. Kick Stage Balance	8
2. Payload Balance	10
V. Kick Stage Performance Trade-Offs	12
VI. Zero- or Negative-g Starting Systems	18
A. Cold Gas Settling	19
B. Positive Expulsion Bladders	19
C. Ullage Chambers	20
VII. Kick Stage Configurations	20
A. Tanks Mounted Adjacent to TCA	21
B. Tanks Mounted Above TCA	24
VIII. Separation and Recovery	26
IX. Missile Flight Safety	27
X. Conclusions	27

APPENDIXES

	<u>Appendix</u>
Kick Stage Sequence of Events	A
Baseline Kick Stage Weight Summary	B
Ullage Chamber Schematic	C

TABLE OF CONTENTS (cont.)

LIST OF FIGURES

<u>Figure No.</u>	<u>Title</u>	<u>Page</u>
1	Baseline Kick Stage	2
2	ARIES 2-D Trajectory Results	5
3	Flight Control Thrust vs Radial CG Offset with Baseline Payload	9
4	Baseline Payload Ballast Required vs Radial CG Offset	11
5	Peak Altitude vs Payload Weight	14
6	Payload Weight vs Peak Time	16
7	Separation Velocity vs Payload Weight	17
8	Modified Aerobee Tanks Adjacent to the TCA	22
9	Spherical Tanks Adjacent to the TCA	23
10	In-Line Modified Aerobee Tanks	25

LIST OF TABLES

<u>Table No.</u>	<u>Title</u>	<u>Table</u>
I	ARIES 2-D Inputs	6
II	Kick Stage 2-D Inputs	13
III	2-D Performance Results	15

I. INTRODUCTION

This report summarizes feasibility and trade-off studies performed to characterize a kick stage which would permit contamination sensitive ARIES payloads to operate in a clean environment. A design goal was to use as many standard or modified Aerobee components as possible, thereby minimizing design time and costs and maximizing reliability.

Performance trade-offs, flight control requirements, negative-g starting systems, missile flight safety and kick stage recovery were all analyzed as separate considerations. The advantages and disadvantages associated with each area were then examined and correlated and a baseline kick stage configuration was chosen.

II. SUMMARY

The baseline kick stage configuration chosen is shown in Figure 1. It is a 42 inch long cylinder, 38 inches in diameter with a total weight of 400 pounds including 180 pounds of propellant. The baseline payload consists of a blunt 15 degree cone on a 38 inch diameter cylinder and weighs 1362 pounds. The overall payload length is 125 inches with the center of gravity 75 inches aft of the nose.

The kick stage is able to regain the performance lost by the ARIES as a result of carrying the additional weight and will provide more than an adequate amount of payload/ARIES separation velocity (greater than 750 FPS with a 1500 pound payload). This is true not only for the baseline payload (1500 lb), but for virtually any payload flyable on an ARIES - thus the kick stage is extremely versatile. Smaller kick stages are also feasible, but reduce this versatility somewhat, due primarily to very low mass fractions.

Flight control of the kick stage was analyzed and found to be within current practice, using cold-gas thrusters controlled by the payload ACS.

BEST AVAILABLE COPY

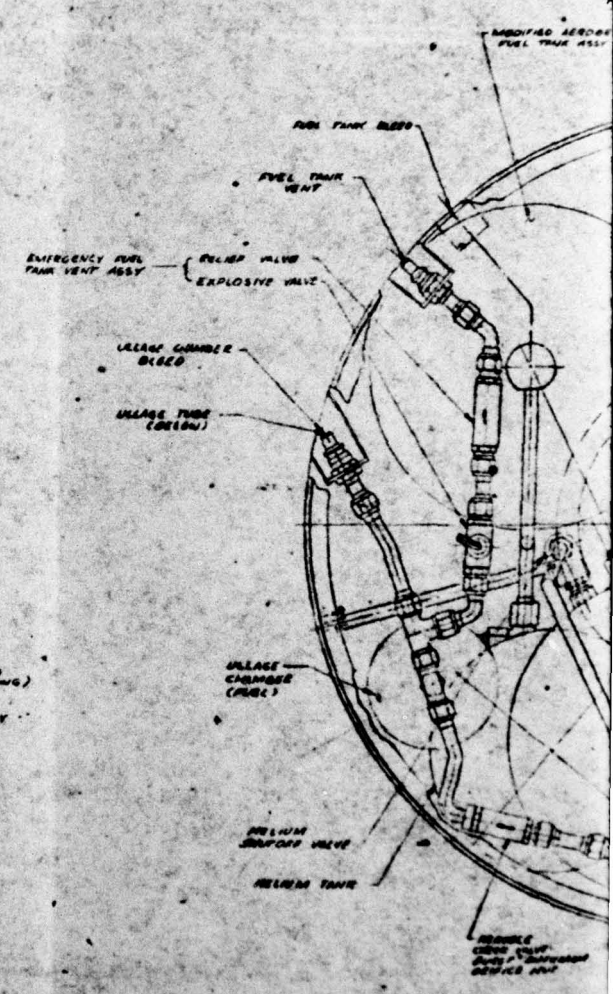
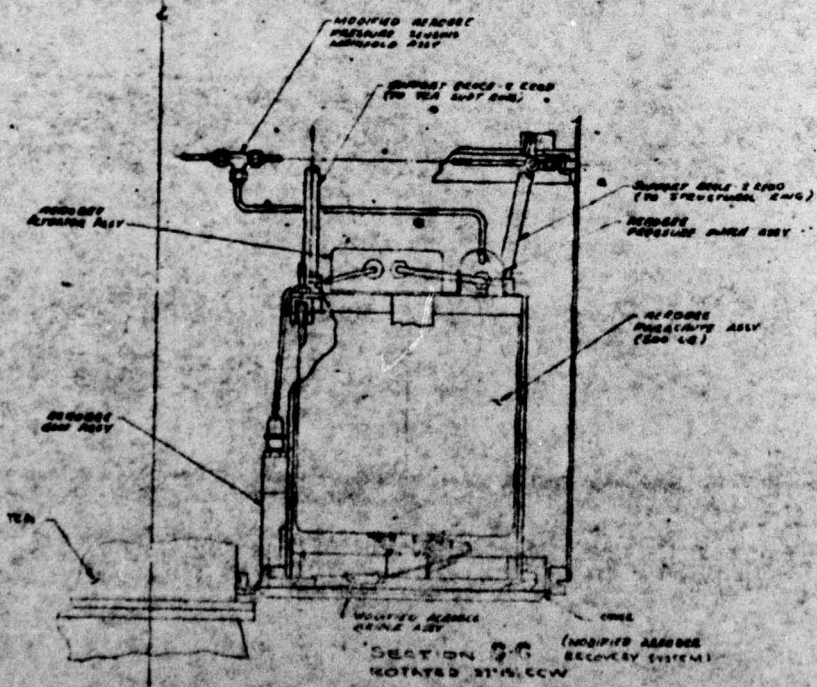

BEST AVAILABLE COPY

BEST

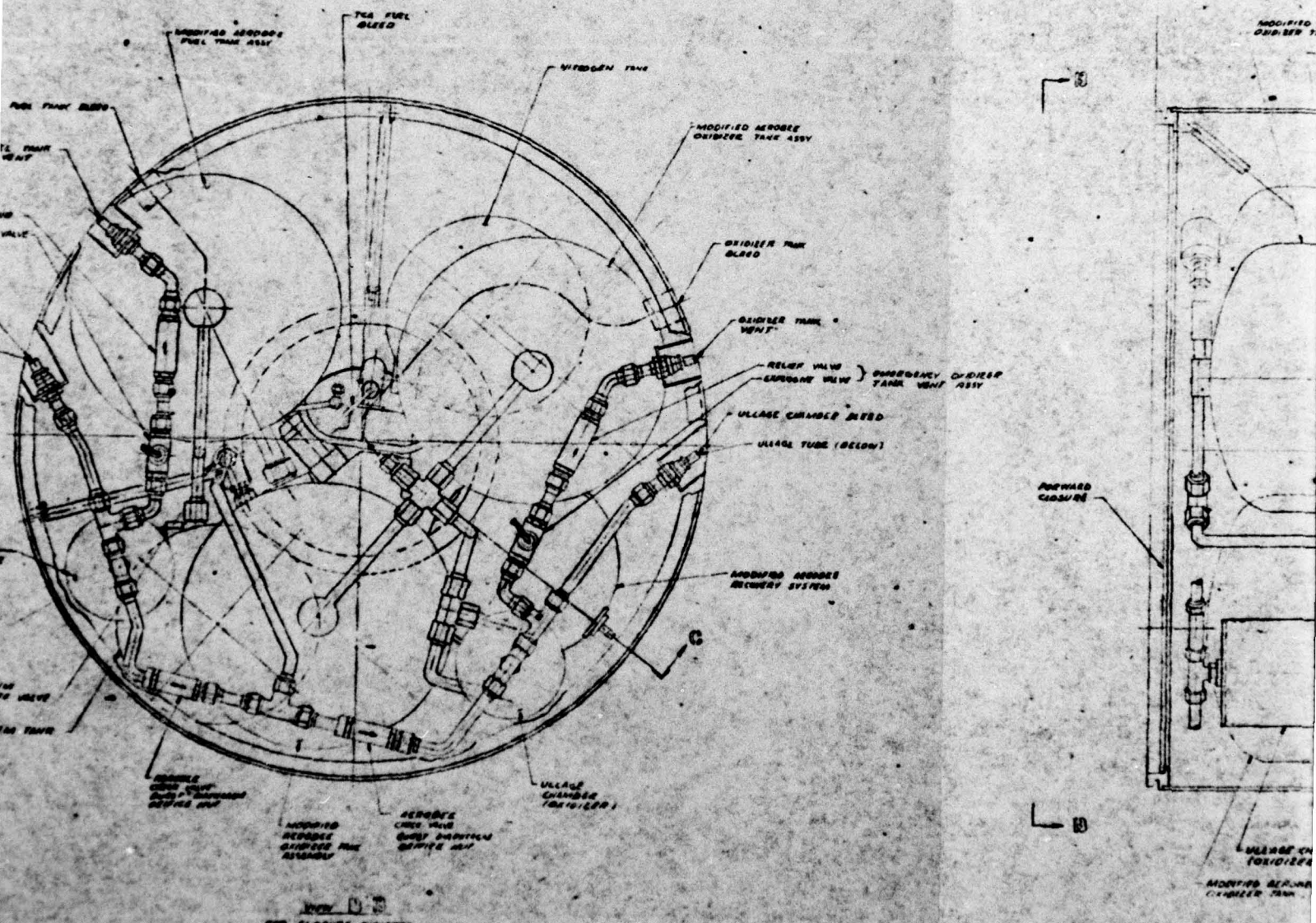
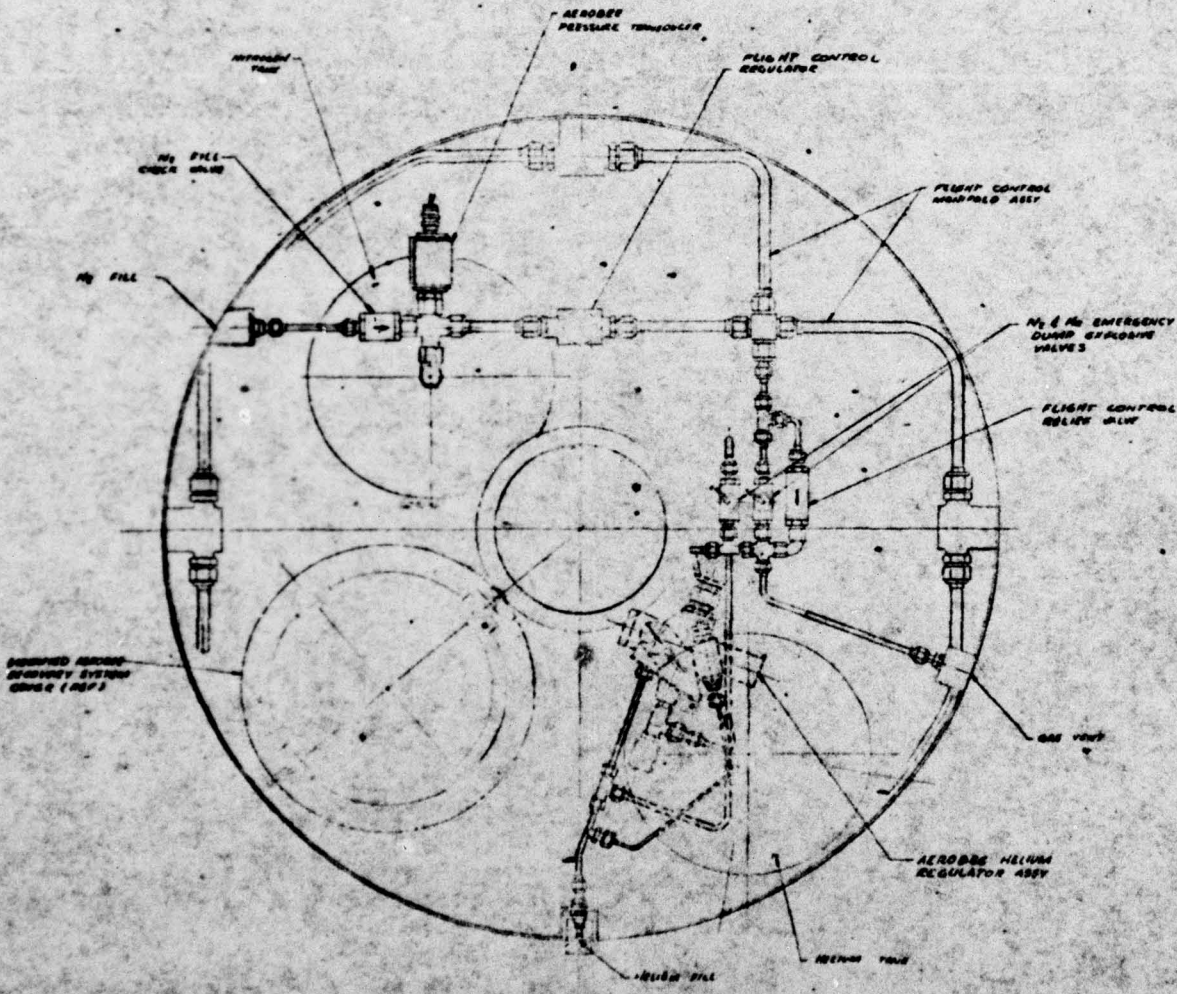

FIGURE 1-

2

BEST AVAILABLE COPY



VIEW A-A
 APP CLOSURE OMITTED

INFORMATION PRINT ONLY
 BASIC INFORMATION FOR THE PUBLIC
 MAY BE OBTAINED FROM THE
 NATIONAL ARCHIVES
 DO NOT FABRICATE

DATE: 2/28/77 DRAWN: J. J. JENSEN CHECKED: J. J. JENSEN	AIR FORCE RESEARCH AND DEVELOPMENT REPORT BASELINE R 164 57808 PAGE NUMBER SAUCAT 1180017
---	---

4

II, Summary (cont.)

Propellant and pneumatic tanks have been located in such a way as to produce negligible unbalancing moments and hence require minimal flight control corrections due to c.g. shifts. It is imperative, though, that the payload be roll balanced to a much smaller value of equivalent radial c.g. offset than the 0.5 in. presently given for the baseline payload. This is to avoid unnecessarily extreme control requirements. Judicious payload packaging and some small amount of ballast should remedy this situation. Unbalance produced by kick stage thrust misalignment is easily counteracted by modest control forces and the control total impulse required is small (see Section IV) due to the relatively short burn time.

When a liquid-propellant rocket engine is in a negative-g or zero-g environment, care must be taken to insure that no gas bubbles are ingested into the propellant feed system during the start phase. Cold-gas propellant settling thrusters and positive-expulsion bladders were evaluated and rejected as means of providing negative-g starts because of the high cost and long lead time for bladders and the inability of reasonably sized cold-gas jets to overcome payload drag at ARIES burnout altitude. As an alternate, a simple ullage chamber was designed to provide an efficient, low-cost system to insure positive propellant bleed to the thrust chamber under negative-g conditions.

Very short kick stages (approximately 26 inches) are possible, but have some disadvantages; mainly, c.g. migration problems during burn with modified Aerobee tanks, or availability of acid compatible spherical tanks. Long kick stages (essentially a shortened Aerobee enclosed in a large shell) are also possible and possess a number of good points, but they result in reduced mass fractions and increased aerodynamic loads. The chosen kick stage configuration has an optimized intermediate length and combines many of the good features of the short and long configurations.

II, Summary (cont.)

Preliminary discussions with WSMR range safety indicate that their requirements are satisfied by the use of standard Aerobee propellant shut-off valves and standard range safety receivers. The relatively simple addition of a propellant tank venting capability, in the event of an aborted kick stage burn, is also incorporated in a manner similar to PLUMAR. Recovery of the kick stage is easily accomplished with a modified Aerobee recovery system.

A detailed sequence of events for the kick stage is included as Appendix A and a weight summary as Appendix B.

III. ARIES NOMINAL PERFORMANCE

In order to determine kick stage operating parameters, it was first necessary to generate an ARIES performance envelope. The simplest and most direct method of obtaining this information was to perform a series of two-degree-of-freedom computer simulations, using nominal ARIES weights, thrust, drag, etc. ALRC ARIES data (Reference 1) provided C_D tables, total impulse, weights, and nozzle exit area to input for the 2-D simulations. The thrust curve and specific impulse for ARIES were modified to reflect the burn time given in Reference 2. The flight path angle was assumed to be constant and equal to the burnout value of 3.3 deg from Reference 2; all runs were simulated for launches from WSMR. Initial results, when compared to actual burnout conditions (i.e., altitude and velocity) from Reference 2, indicated that the simulated ARIES vehicle was over-performing. This tendency was adjusted by increasing the drag reference area until the computed burnout conditions matched those of Reference 2. A set of curves was generated, describing the performance of this nominal ARIES vehicle for various payload weights, and are shown in Figure 2. Subsequently, the simulated ARIES burnout conditions were used as inputs for kick stage 2-D initial conditions and to compare ARIES performance with a kick stage to performance without a kick stage. ARIES data used to generate the 2-D performance curves are summarized in Table I.

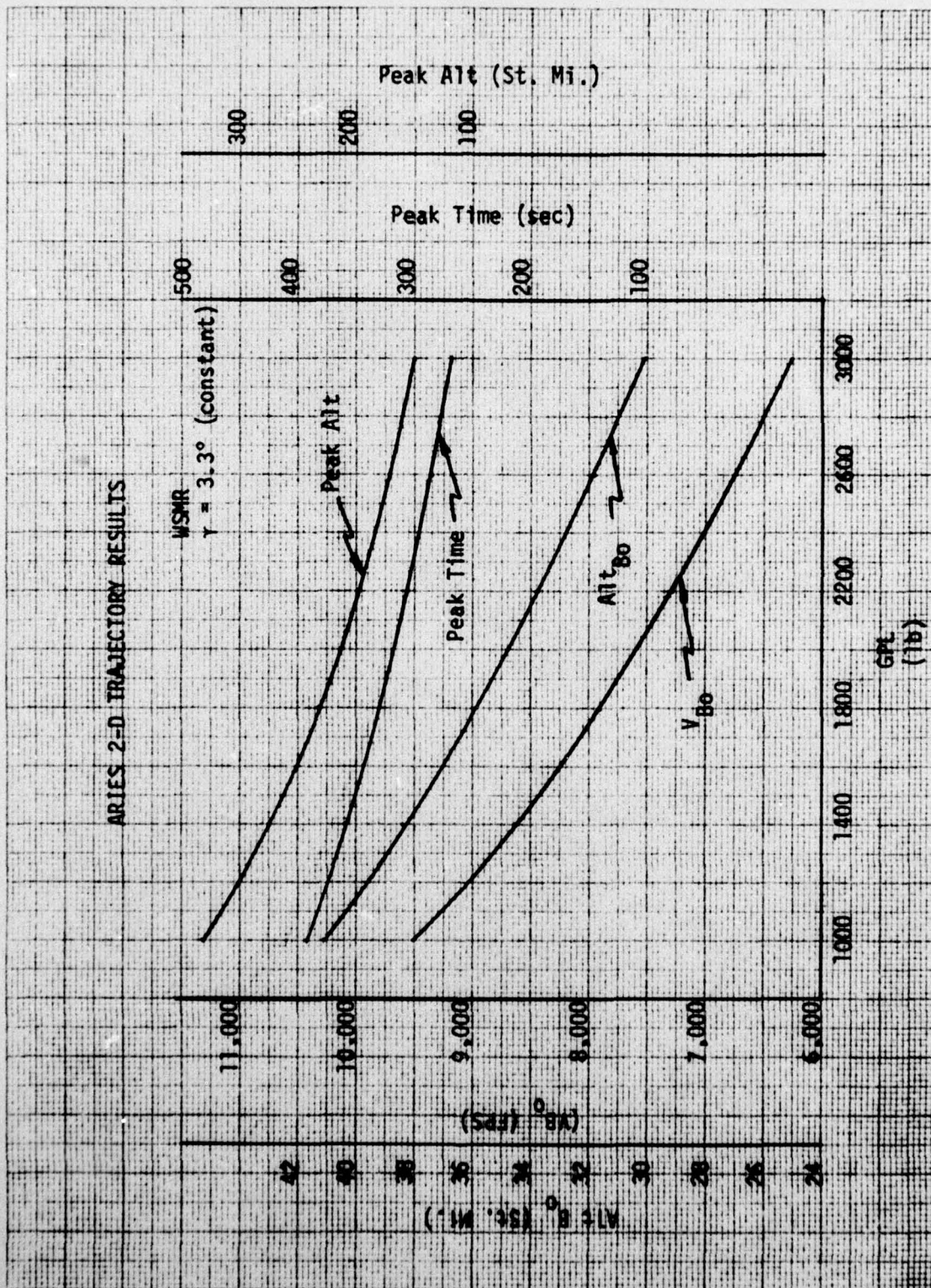

Figure 2

R.G. Starke
6 April 1977

TABLE I
ARIES 2-D INPUTS

All-up Weight (GPL = 0) 12,007 lb
 Expended Weight 10,358 lb
 Burnout Weight 1,649 lb

I_T (vac) = 2,790,515 lb-sec

I_{SP} (vac) = 269.407 sec

WSMR Launch

S_{REF} = 7.79 ft²

A_E = 4.831 ft²

γ = 3.3 deg (constant)

Time (sec)	Thrust (vac) (lb)	Mach No.	C_D	
			On	Off
0.	40,215	0.	.641	.729
2.0	43,157	1.0	1.400	1.515
5.0	47,080	1.2	1.321	1.421
10.0	49,042	2.0	.975	1.041
15.0	49,533	3.0	.770	.813
20.0	49,533	5.0	.591	.605
25.0	49,042	7.0	.559	.568
30.0	48,552	9.0	.562	.566
35.0	48,797	11.0	.565	.564
40.0	46,590			
45.0	45,609			
50.0	45,118			
55.0	44,138			
57.5	32,367			
63.0	5			

IV. FLIGHT CONTROL REQUIREMENTS

This section examines the degree of flight control required to maintain the correct vehicle attitude during kick stage burn.

For the purposes of this study, it has been assumed that the logic necessary for flight control is supplied by the payload ACS system. This is well within the capability of the ALRC Mark VI ACS. The flight control pneumatic system was assumed to be totally contained within the kick stage with only electrical separation necessary during separation of the payload.

Flight control nozzles (nitrogen operated) were located at the aft end of the kick stage to provide the longest possible moment arm, and sized to deliver a control moment that would be twice the calculated maximum unbalancing moment. Contributors to the unbalancing moment were kick stage thrust misalignment and vehicle radial c.g. offset from the centerline.

The amount of allowable vehicle unbalance is limited by the thrust level required for control, rather than by total impulse, due to the short kick stage burn times. Maximum thrust is restricted by the use of reasonably sized jets, valves, lines, and working pressures. A jet which produces 22 lb of thrust, with a chamber pressure of 500 psi, requires a throat diameter of about 0.2 in. These values permit the use of standard size fittings and lines and a standard Aerobee regulator (possibly the same one used to pressurize the propellant tanks) and are therefore recommended for service. As will be shown later, this thrust level should provide an entirely adequate control moment, but could be increased considerably by increasing jet throat areas. For example, at the same pressure (500 psi), an 0.3 in. dia throat would produce about 50 lb of thrust. The following sections discuss the degree of vehicle unbalance allowed by the chosen control thrust level.

A. KICK STAGE THRUST MISALIGNMENT

The 2σ value of thrust misalignment used for calculations (0.125 deg, Reference 3) produces an unbalanced torque equivalent to about 0.07 in.

IV, A, Kick Stage Thrust Misalignment (cont.)

of c.g. offset. This may be considered a minimum value for unbalance, as thrust misalignment does not readily lend itself to improvement. Figure 3 illustrates the relationship between payload unbalance and control thrust for the baseline payload of Reference 2 combined with the baseline kick stage shown in Figure 1. Note that about 8 lb of flight control thrust is necessary to oppose thrust misalignment in addition to any requirements for balancing radial c.g. offset. This would require about 1 lb of GN_2 , based on an 8.28 sec burn time for the baseline kick stage.

B. VEHICLE BALANCE

Vehicle static roll unbalances produce a radial c.g. offset that must be countered by the flight control system. Throughout this analysis, a worst-case situation is assumed wherein c.g. offsets and thrust misalignments are in the same direction and, hence, directly additive. Dynamic roll balance is unimportant, as far as flight control is concerned, because the vehicle does not spin during the powered portion of the flight.

Radial c.g. offsets can be either constant or transient, in magnitude as well as location. Propellant and pneumatic flows may produce a shifting c.g. Center of gravity migration, during kick stage burn, would be caused by the kick stage only, as the payload presumably has no fluids flowing at that time.

1. Kick Stage Balance

Radial c.g. offsets of the kick stage could contribute heavily to the amount of flight control required. Propellant tanks which are not mounted on the centerline will produce a radial c.g. travel during burn unless properly located (a result of different oxidizer and fuel weights and flow rates). Several otherwise acceptable kick stage configurations were discovered

FLIGHT CONTROL THRUST VS RADIAL CG OFFSET
WITH BASELINE PAYLOAD

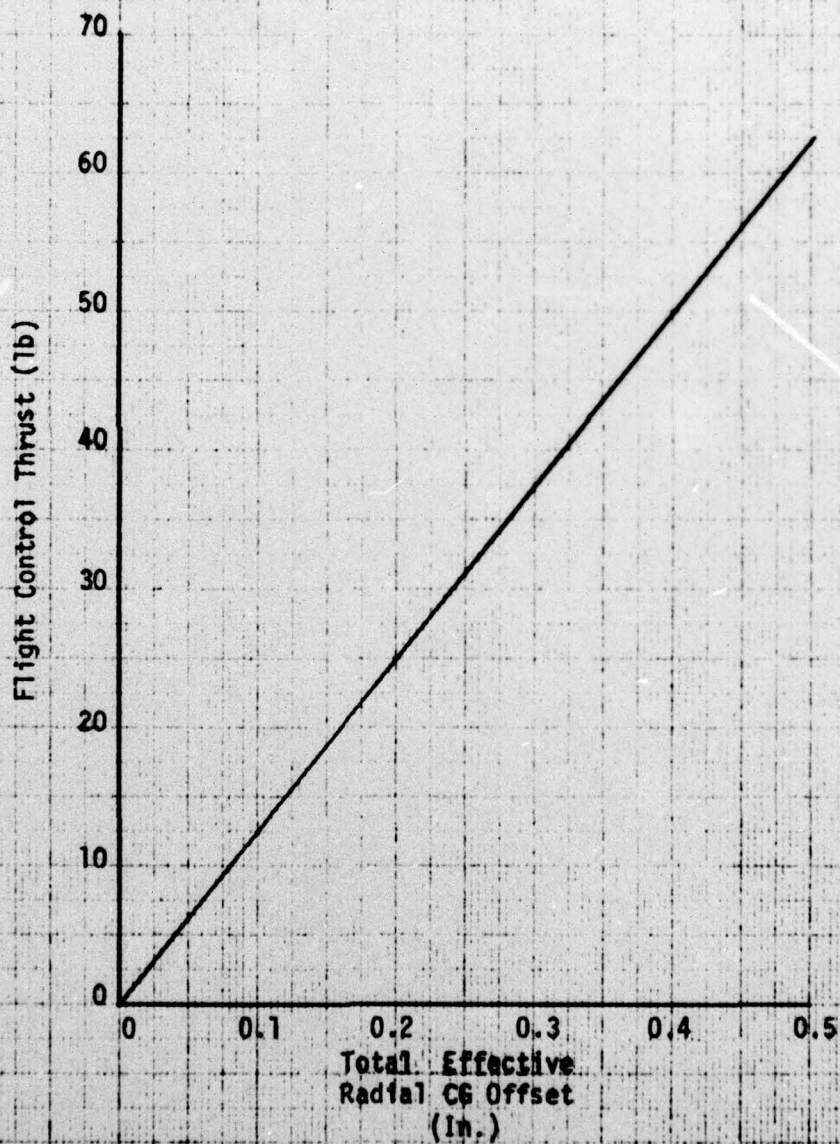

Figure 3

IV, B, Vehicle Balance (cont.)

to produce an excessive amount of unbalance by themselves and hence were rejected. Others produced smaller amounts of c.g. travel which would have been acceptable alone, but not in conjunction with an, as yet, relatively unknown degree of payload unbalance. This uncertainty led to the decision to consider only those tank arrangements which produce a kick stage radial c.g. located on the vehicle centerline both loaded and empty. Under these conditions, kick stage c.g. travel is negligible and need not be accounted for when sizing the flight control system.

2. Payload Balance

If we assume an insignificant amount of unbalance in the kick stage, then the maximum control thrust, less the portion used to control thrust misalignment, is available to balance payload radial c.g. offsets. Static balancing is a relatively simple procedure, so, rather than size the flight control system to handle large unbalances, it would be much more effective to select a reasonable thrust level and then balance the payload to the required limits. Thrust misalignment accounts for 8 lb of the design maximum 22 lb of flight control thrust, leaving 14 lb to balance the payload. From Figure 3, then, it can be seen that the combined payload and kick stage must be balanced to give an effective radial c.g. offset of 0.1 in. or less (total offset = 0.17 in.), which should present no major problems. The payload c.g. offset of 0.5 in. specified in Reference 2 for the baseline payload would obviously require extreme amounts of control and is unacceptable. Figure 4 illustrates the amount of ballast necessary to roll balance the baseline payload as a function of radial c.g. offset. The ballast required to eliminate the baseline payload's roll unbalance is not excessive (about 38 lb), but could be substantially lessened by payload repackaging. Another method of improving the total vehicle roll balance would be to design a known amount (and location) of radial c.g. offset into the kick stage which could be used to counter a measured payload unbalance with a minimum of ballast.

BASELINE PAYLOAD
BALLAST REQUIRED VS RADIAL CG OFFSET

Payload Wt = 1362 lb

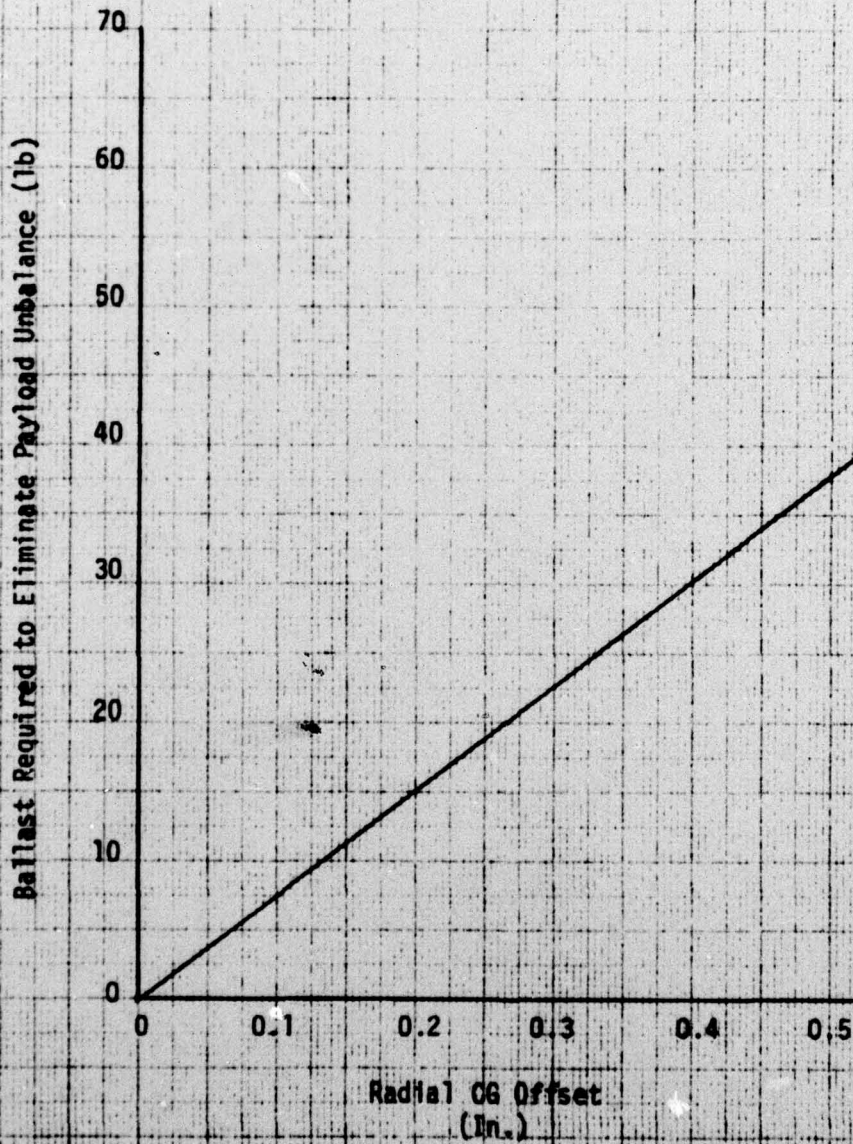

Figure 4

V. KICK STAGE PERFORMANCE TRADE-OFFS

In the absence of specific requirements for kick stage performance, three basic kick stages using different amounts of propellant were investigated to establish working performance limits. All stages considered were assumed to use standard Aerobee thrust versus time tables, with varying burn times to set the amount of propellant used. Input data used for 2-D simulations are summarized in Table II.

Figure 5 and Table III present peak altitude results versus payload weight for each kick stage, and Figure 6 shows time to peak altitude. Also shown for comparison are the ARIES 2-D performance results. It is interesting to note that the performance with the 300-lb or 400-lb kick stages is nearly identical to that obtained with an ARIES alone, but the 200-lb kick stage loses about 5%. From a peak altitude or experiment time standpoint, therefore, either of the two larger kick stages would be acceptable for any ARIES payload which requires the maximum possible performance. The 200-lb kick stage should also be acceptable for use with payloads that would not be hampered by the slight decrease in performance.

Ideal ΔV calculations of ARIES payload separation velocity, plotted in Figure 7, clearly show large increases in separation velocity with increasing kick stage size. If peak altitude and experiment time are relatively unimportant, the kick stage may then be sized to deliver the required separation velocity.

The 400-lb kick stage, though, has several advantages over the other stages. The 200-lb kick stage does not regain the performance lost by the ARIES and provides a much smaller separation velocity than the other stages. The 300-lb kick stage, by virtue of its lower weight and propellant mass fraction, is inherently more sensitive to changes in inert weights. For a given inert weight increase, then, the 300-lb kick stage would lose more performance than the 400-lb stage. Therefore, the largest kick stage would

R.G. Starke
6 April 1977

TABLE II
KICK STAGE 2-D INPUTS

Kick Stage Total Weight	400 lb*	300 lb	200 lb
Propellant Weight	<u>180 lb</u>	<u>120 lb</u>	<u>40 lb</u>
Burnout Weight	<u>220 lb</u>	<u>180 lb</u>	<u>160 lb</u>
I_T (vac)	42,816 lb-sec	28,544 lb-sec	9,514 lb-sec
Burn Time	8.28 sec	5.52 sec	1.84 sec
WSMR Launch			
S_{REF}	= 7.876 ft ²		
A_ϵ	= 0.6392 ft ²		
QE	= 86.7 deg		
Thrust	= 5171 lb		
C_D	= 0.5		
I_{SP} (vac)	= 237.86 sec		

*Selected Baseline Kick Stage

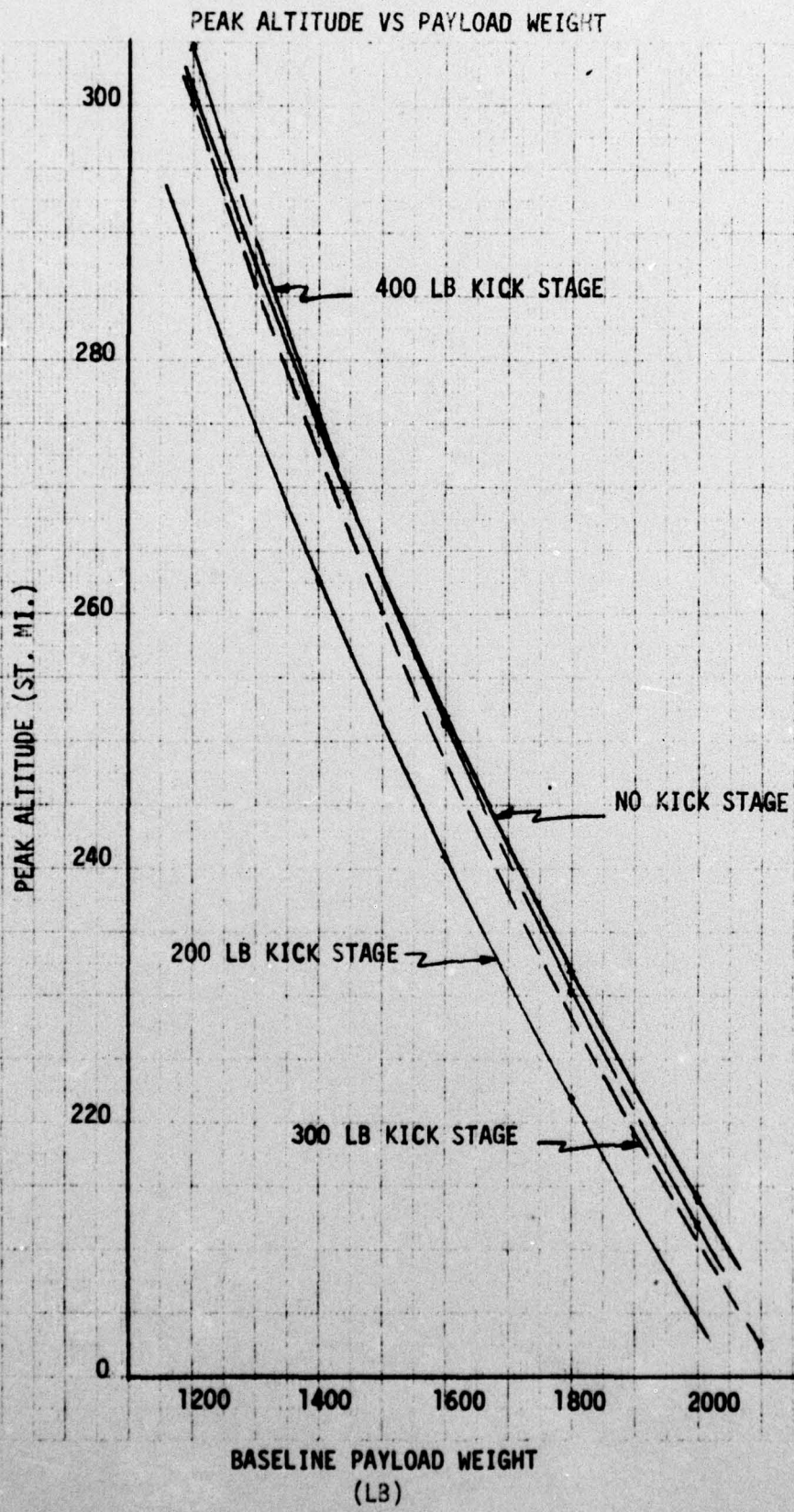

Figure 5

RG Starke
14 April 1977

TABLE III
2-D PERFORMANCE RESULTS

Payload Weight (lb)	Peak Altitude			
	ARIES	200 lb Kick Stage (St. Mi.)	300 lb Kick Stage	400 lb Kick Stage
1200	301.1	287.8	300.1	304.7
1400	274.8	262.7	272.7	275.7
1600	252.0	240.9	247.8	251.3
1800	231.9	221.9	227.8	230.3
2000	214.2	204.4	210.7	212.0

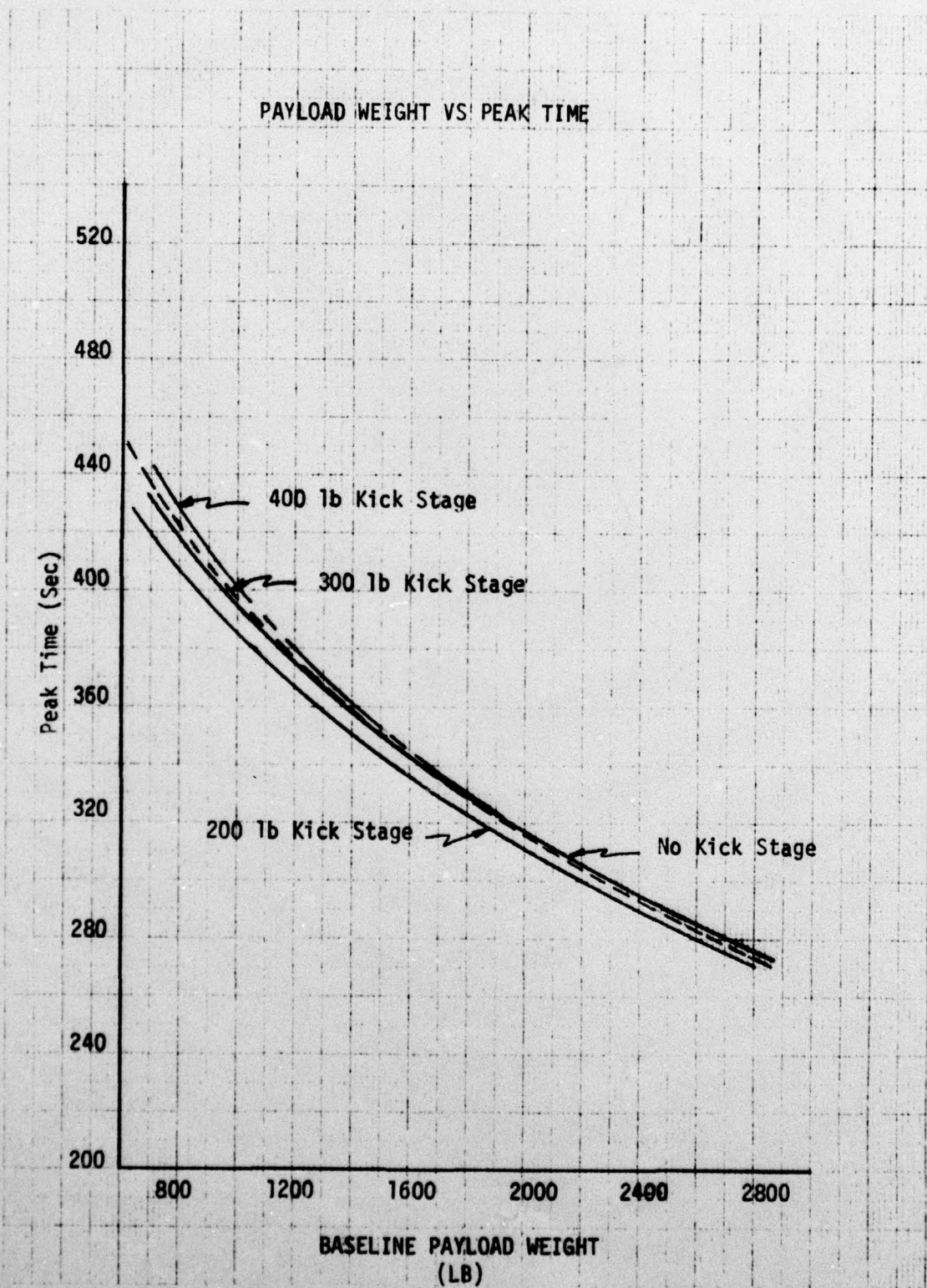

Figure 6

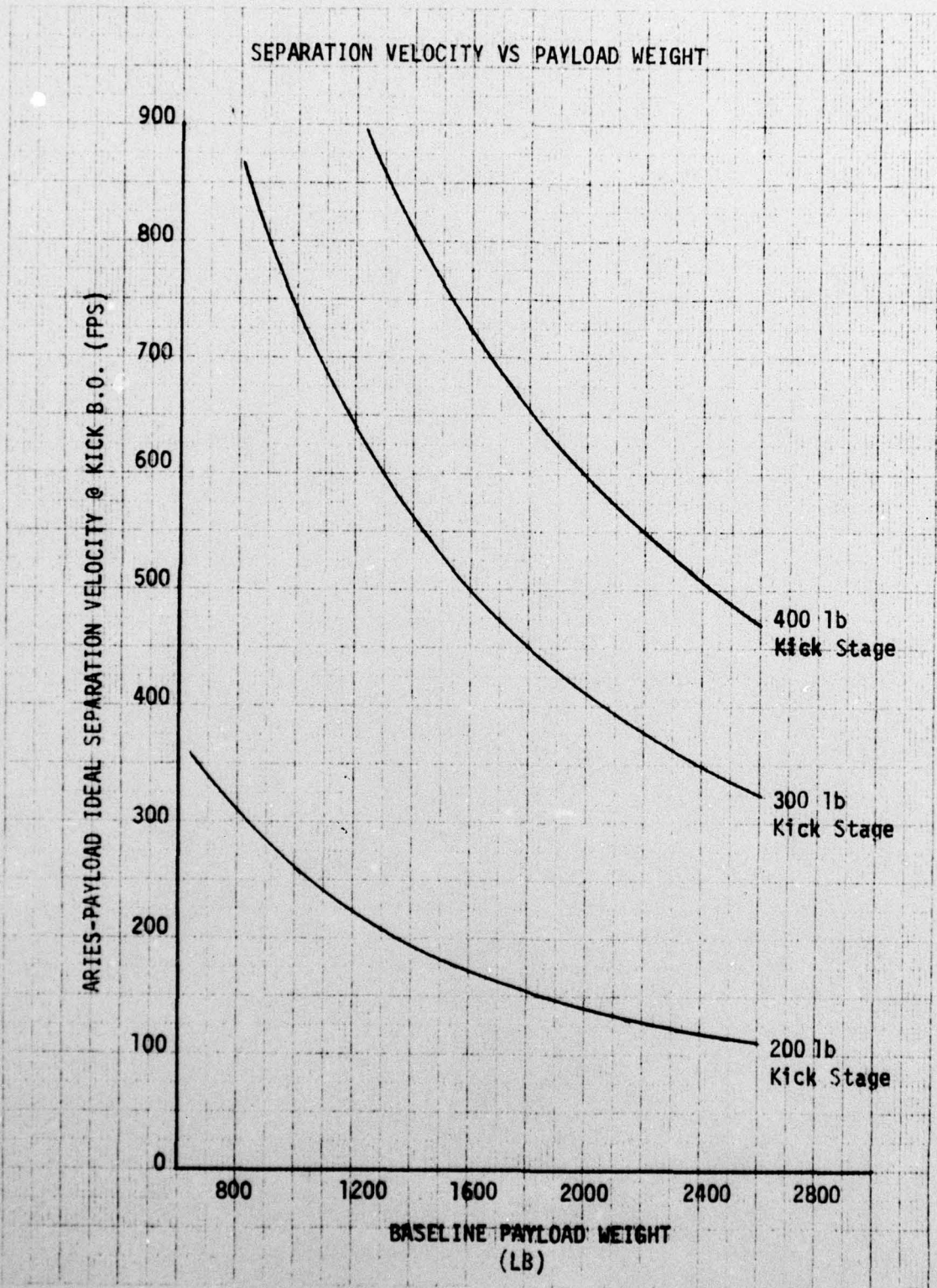

Figure 7

V, Kick Stage Performance Trade-Offs (cont.)

be least affected by the addition of an extra component, increased structural requirements, etc. There is no significant cost advantage associated with a 300-lb kick stage, as the 400-lb stage merely adds one or two inches of external skin and tank shell plus, of course, the extra propellant (60 lb). The 400-lb kick stage was chosen as the baseline configuration, then, because it meets or exceeds performance requirements and allows more versatility and conservatism in calculations at little or no increased cost over the smaller stages.

VI. ZERO- OR NEGATIVE-G STARTING SYSTEMS

Liquid rocket systems which must be started under other than positive-g conditions require special provisions to insure positive propellant bleed at the thrust chamber. Propellant tanks generally include a gas/vapor filled ullage volume at the top which controls the tank pressurization rate and allows for propellant thermal expansion. Under zero or negative-g conditions, as experienced during ARIES thrust delay, the propellants will slosh or migrate forward, leaving the aft end (outlet port) of the tank and part of the line to the TCA filled with the gas/vapor mixture. If a start was attempted under these circumstances, the engine would begin to burn the propellants remaining in the TCA and associated lines. The thrust generated would again settle the propellants to the aft ends of the tanks, but a large gas bubble could be trapped in the lines. The hesitation and uncontrolled flow caused by the bubble would produce unpredictable ignition transients which could result in combustion instability and damage to the TCA. The kick stage, therefore, must possess some means of either preventing propellant migration under negative-g conditions or of settling the propellants to the bottoms of the tanks prior to firing.

Three means of providing negative-g starting systems were considered for the kick stage: cold-gas settling jets; positive expulsion bladders; and ullage chambers.

VI, Zero- or Negative-g Starting Systems (cont.)

A. COLD-GAS SETTLING

Nitrogen-powered settling jets would be compatible with practically any configuration of propellant tanks. This system would also possess the capability to be reused with a minimum of refurbishment (replacing squib-operated valves and recharging the pressure bottle). Operation of the system is very simple, consisting of merely triggering explosive valves which allow a nitrogen bottle (separate from the flight control system) to blow down through the jets, producing enough thrust to settle the propellants. This is a proven system and was utilized in the first USA in-space restart.

There is, however, a major disadvantage in using a cold-gas settling system for this application. ARIES burnout (for the payloads under consideration) occurs at an altitude where drag effects on the kick stage vehicle are large enough to prohibit the immediate use of cold-gas thrusters. Long coast times (30-60 sec) would be required to permit the kick stage to reach an altitude at which reasonably sized gas jets could overcome the drag and produce a net positive-g condition to settle the propellants. Another disadvantage is the added cost and complexity associated with its separate pneumatics system. Cold gas settling, therefore, reduces the amount of experiment time available and limits the versatility of the kick stage, and is therefore unsuitable for this application, due principally to the existence of sensible atmosphere at the action requirement time.

B. POSITIVE EXPULSION BLADDERS

Bladders are also applicable to the entire range of propellant tank types considered, and have the additional advantage of providing the kick stage with the capability for negative-g starts.

However, bladders for use with the Aerobee liquid propellant oxidizer employ high-technology, difficult-to-mold materials which would probably require extensive development and testing and, hence, excessive non-recurring costs. For this reason, coupled with the fact that they are not reusable, bladders would presumably be the least desirable starting system and are not recommended.

VI, Zero- or Negative-g Starting Systems (cont.)

C. ULLAGE CHAMBERS

Completely full propellant tanks are inherently suitable to negative-g starts, as the propellants are unable to migrate and allow air/gas to become trapped in the lines. The propellants must be free, though, to expand and contract with temperature variations to avoid damaging the tanks or creating excessive pressures at the TCA burst diaphragms, causing a diaphragm to rupture prematurely.

A simple solution to this problem is to connect small chambers to the full propellant tanks (fuel and oxidizer), as shown schematically in Appendix C. The chamber contains a small amount of propellant, as well as the ullage volume necessary for efficient tank operation over the operating temperature range (hence the term "ullage chamber"). A relatively high cracking-pressure check valve vents excess tank pressure by allowing expanding propellant to flow into the ullage chamber. Similarly, a low cracking-pressure check valve prevents buckling of the tanks should the propellants contract by allowing return flow. The tanks thus remain full at all times, enabling the kick stage to start under negative-g conditions with no danger from entrapped gases.

This is a relatively simple and inexpensive device to fabricate, use, and refurbish and, as such, is ideal for use with the kick stage.

VII. KICK STAGE CONFIGURATIONS

Various propellant tank shapes and arrangements within the kick stage have decided effects on parameters such as ease (and cost) of fabrication and field servicing, as well as on performance and structural considerations. As stated earlier, only those tank configurations which can be balanced to eliminate radial c.g. travel during kick stage burn were considered.

VII, Kick Stage Configurations (cont.)

Two basic kick stage types were investigated--those with propellant tanks mounted adjacent to the thrust chamber and those with tanks mounted above the thrust chamber.

A. TANKS MOUNTED ADJACENT TO TCA

This type of tank arrangement allows a very short kick stage, but has few other advantages.

Space restrictions do not permit balancing of the kick stage to completely eliminate c.g. migration during burn when modified Aerobee propellant tanks are used. The 200-lb kick stage with modified Aerobee tanks is feasible, though, as it does not use enough propellants to cause a significant c.g. travel (see Figure 8).

Spherical propellant tanks can be designed to balance the kick stage properly for all propellant loads considered (Figure 9). New tanks, however, especially ones compatible with the Aerobee oxidizer, would require a substantial amount of development and testing and would also require the design of associated components (bosses, baffles, diffusers, etc.).

This type of tank arrangement, then, seems to offer only a shortened total kick stage length as an advantage. If this is a necessary feature, modified Aerobee tanks may be used for the 200-lb stage, but new tanks would have to be used with the 300-lb and 400-lb stages. The standard 3-strut thrust structure would have to be adapted to a 4-strut configuration to allow positioning of the propellant tanks. Packaging space would be extremely limited, thus some difficulty with assembly and servicing could be expected.

MODIFIED AEROBEE TANKS ADJACENT TO THE TCA

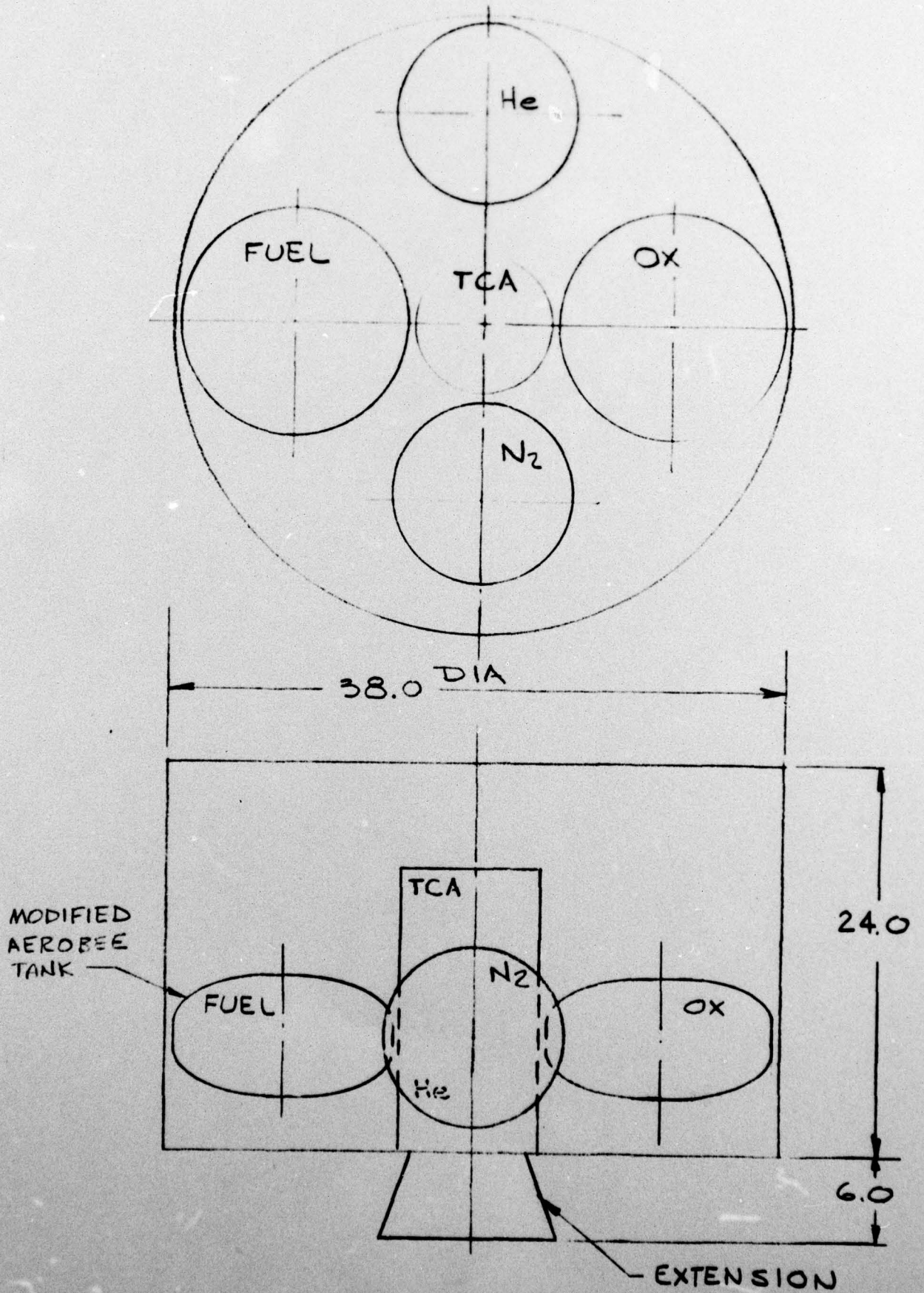

Figure 8

SPHERICAL TANKS ADJACENT TO THE TCA

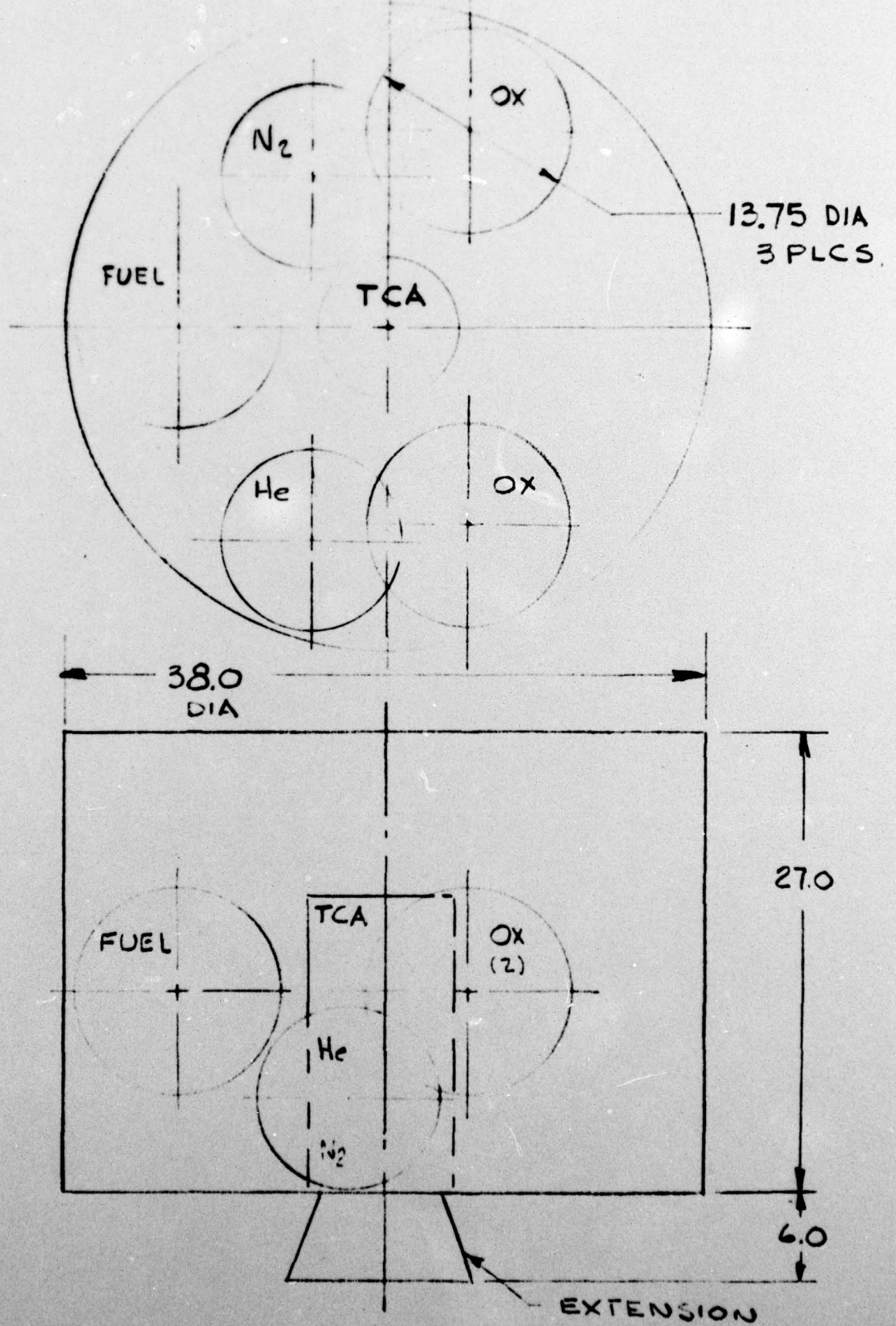

Figure 9

VII, Kick Stage Configurations (cont.)

B. TANKS MOUNTED ABOVE TCA

Another potential configuration involves locating the tanks above the TCA.

This type of arrangement permits modified Aerobee tanks to be used with all propellant loads considered, with ample room for balancing to eliminate c.g. travel during burn. New tank designs, therefore, need not be considered for this type of mounting, as they offer no advantages over modified Aerobee tanks.

The simplest arrangement of this type is to use in-line, shortened Aerobee tanks as shown in Figure 10. This arrangement, though, unnecessarily lengthens the kick stage and reduces the mass fraction by increasing the amount of skin and internal structure required.

The most effective propellant tank configuration was incorporated with the baseline kick stage shown in Figure 1. Three equal volume tanks (one for fuel, two for oxidizer) allow the shortest possible kick stage length for this type of mounting and the highest mass fraction. These tanks are especially compatible with the ullage chambers already discussed; with all three tanks filled completely, as required for proper operation of the ullage chambers, the correct proportion of fuel to oxidizer is automatically obtained, allowing for a slight fuel residual which prevents thermal damage to the TCA by remaining in the regenerative cooling jacket through burnout. The use of three equal-sized tanks also greatly simplifies fabrication and tooling and is relatively inexpensive.

These tanks would be designed with a small amount of extra capacity to guard against any possibility of early shutdown caused by non-simultaneous depletion of the paired oxidizer tanks. Simultaneity is assured by hydraulically balanced tank outlet lines with very low pressure drop in the two legs when compared with the pressure drop in the rest of the system.

IN-LINE MODIFIED AEROBEE TANKS

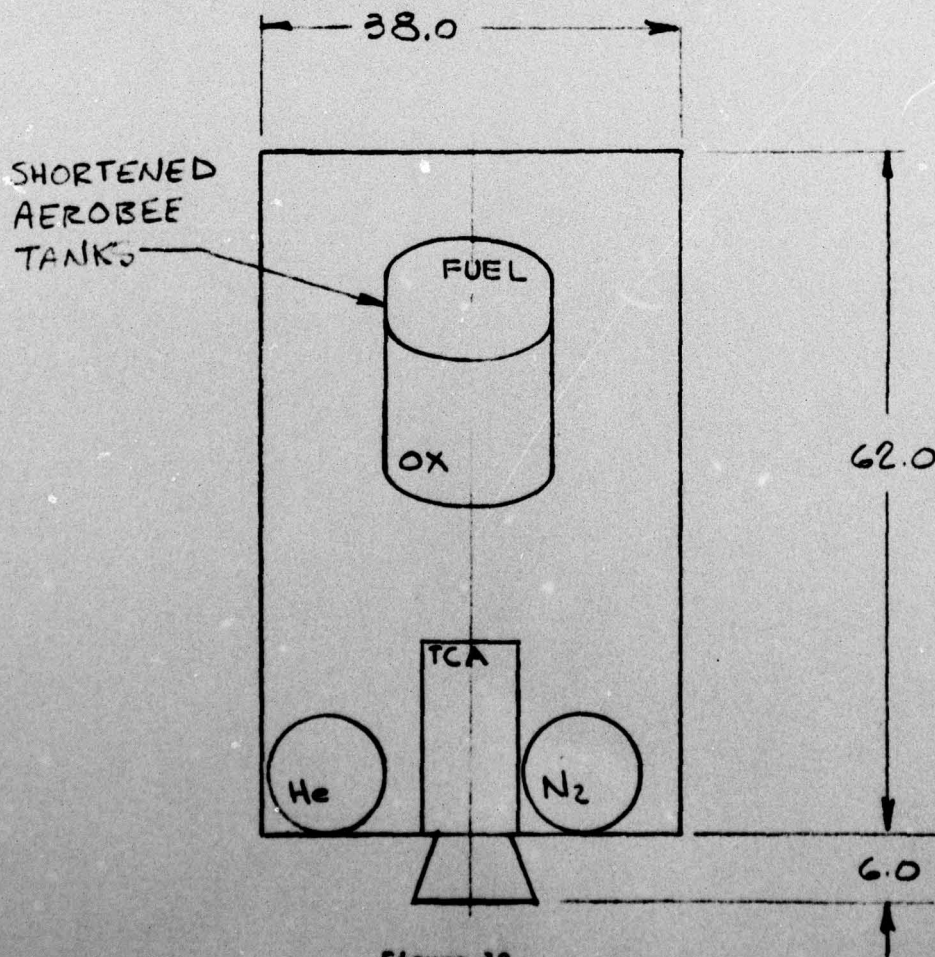
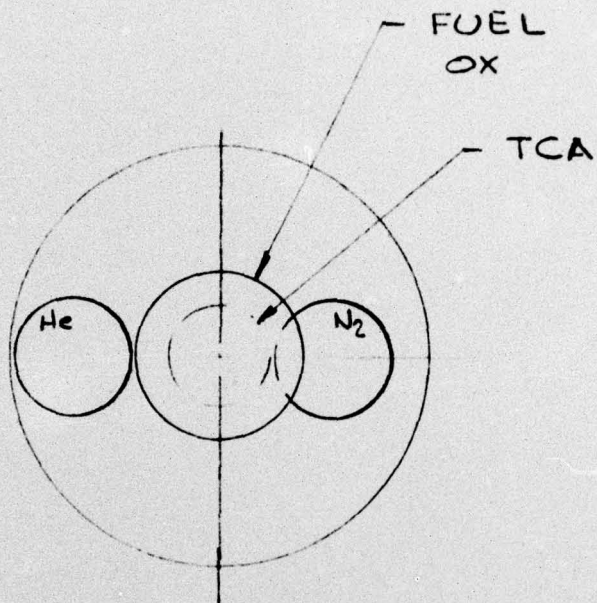

Figure 10

VIII. SEPARATION AND RECOVERY

Separation of the payload from the kick stage must be accomplished not only under normal circumstances, but also in the event of an ARIES or kick stage malfunction. In either case, the prime signals for ARIES-kick stage and then kick stage-payload separation would come from the payload ACS, with a backup signal coming from range safety and/or an on-board timer. The signal(s) would activate each separation system through redundant initiators, thus virtually assuring separation. Kick stage separation joints will be designed to be compatible with standard ARIES manacle-type separation systems and, since the kick stage is joined to the payload by an electrical connection only, severance is a straightforward procedure.

Recovery of the payload, after separation from the kick stage, is accomplished by a self-contained recovery system and is not discussed in this report.

A slightly modified Aerobee recovery system will be used to recover the kick stage. Reentry stability and heating were analyzed for a worst-case payload (i.e., 1200-lb payload, 400-lb kick stage, and a C_D of 0.8). Aerodynamic heating was found to be of some concern, but should be controlled with careful design. Parachute deployment will be within current experience at the predicted dynamic pressure of 35 psf at 20,000 ft. In the baseline configuration, a 24 ft dia flat, circular chute (standard Aerobee 500-lb land recovery system) is mounted off-center on the kick stage (see Figure 1). This constrains the kick stage to descend with a canted attitude such that impact shocks are absorbed through a known portion of the forward ring to protect the internal components as much as possible. Standard Aerobee barometric switches are employed to initiate kick stage recovery by triggering an explosive device which ejects the recovery system cover plate (identical to Recoverable Aerobee recovery system) and deploys the drogue chute. A standard delay mechanism then releases the main chute which lowers the kick stage at a terminal velocity of about 24 ft per sec.

IX. MISSILE FLIGHT SAFETY

Informal discussions with WSMR range safety indicate that an "enable" or "disable" capability for the kick stage is necessary in the event of an ARIES malfunction to prevent the kick stage or the payload from impacting off range. A complete disable system, using ground-commanded, squib-operated propellant shut-off valves, is an integral part of standard Aerobee vehicles and is acceptable to WSMR range safety. The system would be disabled only in the event of an ARIES malfunction or a flight trajectory resulting in the ARIES near one edge of the range. Thus, no experiment time will be lost due to missile flight safety requirements.

Unused flight control nitrogen and tank pressurization helium will be vented to preclude hazardous recovery operations.

X. CONCLUSIONS

In conclusion, the recommended baseline kick stage will meet or exceed all performance requirements while retaining the low cost and proven reliability associated with Aerobee hardware. This is readily seen in Appendix A which presents a detailed sequence of events that emphasizes the kick stage's reliance on Aerobee and other standard ALRC components.

REFERENCES

1. ARIES 2-D Data; Sounding Rocket Operations Notebook, "2-D Data, New Vehicles" (unpublished).
2. Baseline Payload Data; TWX from C. P. Chalfant, 10 March 1977.
3. "Development of A-170, Analysis," Aerojet Report No. 8720-04R-1, June 1968.

APPENDIX A

KICK STAGE SEQUENCE OF EVENTS

The following sequence of events discusses the operation of the kick stage and also lists major components associated with each key event. Nuts and bolts, fittings, bosses, tube and hose assemblies, harnesses, and other small components are standard or modified Aerobee hardware. With the exceptions of the ullage chamber and the standard ARIES manacle-type separation joint, all of the kick stage components are flight-proven hardware used on Aerobees or other ALRC sounding rocket vehicles and flight systems. Listed part numbers are not, in all cases, the exact part that will be used, but represent that type of component (for example, similar regulators with different outlet pressure settings). The almost total dependence on proven hardware greatly enhances the reliability, simplicity, and cost of the kick stage.

<u>Event or Operation</u>	<u>Major Components Used</u>
1. Fill and bleed all propellant lines, tanks, and the TCA	. Tank heads, Aerobee, 6 ea, P/N 2-060249
2. Fill and bleed ullage chambers; test both pairs of relief valves; set propellant levels	. Ullage chamber, new design, 2 ea . Relief valve, Circle Seal, 2 ea, P/N 232A10TB and P/N 532A-10TB-50
3. Fill pneumatic systems	. Pressure bottle, Hi-Hi Star, 2 ea, P/N 200207-1 . Pressure transducer, Serv- onics, 2 ea, P/N 4030111 . Check valve, Circle Seal, 1 ea, P/N 232A10TB
4. ARIES launch and burn induce stresses in kick stage structure	. Braces, struts, rings, and external skin, various ALRC vehicles
5. ARIES-kick stage separation	. Manacle separation joint, ARIES, 1 ea

Appendix A (cont.)

<u>Event or Operation</u>	<u>Major Components Used</u>
6. Kick stage flight control by payload ACS	<ul style="list-style-type: none"> . Regulator, Futurecraft, 1 ea, P/N 402C6A-A-10-300 . Pitch and yaw nozzles (with integral solenoid valve), ALRC, 4 ea, P/N 1183403-9 . Relief valve, Circle Seal, 1 ea, P/N 5132A-10TB-600
7. Squib-operated piston closes overboard helium dump; explosive valve initiates propellant regulator operation	<ul style="list-style-type: none"> . Regulator assembly, Aerobee, 1 ea, P/N 1117490-5 . Explosive valve, Conax, 1 ea, P/N 18301200
8. Pressurization line diaphragms burst; propellant tanks and lines pressurize	<ul style="list-style-type: none"> . Burst diaphragm, Aerobee, 2 ea, P/N 1369143-1 . Check valve, Futurecraft, 2 ea, P/N 232A10TB . Orifice nut, Aerobee, 1 ea, P/N 1369252-1 and P/N 1369253-1 . Diffuser, Aerobee, 3 ea, P/N 2-003557
9. Propellant valve diaphragms burst; ignition begins; rising chamber pressure fully opens propellant valve; burn continues	<ul style="list-style-type: none"> . Propellant valve, Aerobee, 1 ea, P/N 1369320 . Burst diaphragm, Aerobee, 1 ea, P/N 1103290-1 and -5 . Mixture ratio orifice, Aerobee, 1 ea, P/N 34802-4 . TCA, Aerobee, 1 ea, P/N 1369173 . Nozzle extension, Aerobee, 1 ea, P/N 1184067 . TCA mounting strut, Aerobee, 3 ea, P/N 1369254-1 . Aft ring, Aerobee, 1 ea, P/N 1369226-1
10. Kick stage burnout or command shutdown	<ul style="list-style-type: none"> . Fuel shut-off valve, Aerobee, 1 ea, P/N 1115937 . Ox shut-off valve, Aerobee, 1 ea, P/N 1369255
11. Pressure is locked up in propellant tanks (500 psi)	<ul style="list-style-type: none"> . Helium shut-off valve, Aerobee, 1 ea, P/N SG200535
12. Separation from payload; reentry	<ul style="list-style-type: none"> . Manacle separation joint, ARIES, 1 ea

Appendix A (cont.)

<u>Event or Operation</u>	<u>Major Components Used</u>
13. Propellant tanks are vented to safe recovery pressure and again locked up	. Explosive valve, Conax, 2 ea, P/N 18301200 . Relief valve, Circle Seal, 1 ea, P/N 5132A-10TB-100 and -15
14. Dump unused nitrogen and helium	. Explosive valve, Conax, 2 ea, P/N 18301200
15. Barometric switches trigger explosive pistons which eject the recovery system cover plate; drag on cover deploys drogue chute; delayed cutter releases main chute; final descent and impact	. Pressure-sensing manifold, Aerobee, 1 ea, P/N 1118143-1 . Switch assembly, Aerobee, 1 ea, P/N 1118112-1 . Cover eject piston, Aerobee, 2 ea, P/N 1184057-1 . Cover plate, Aerobee, 1 ea, P/N 1118100 . Bridle, Aerobee, 1 ea, P/N 1111603 . Parachute assembly, Aerobee (500 lb), 1 ea, P/N SG200281-2

APPENDIX B

BASELINE KICK STAGE WEIGHT SUMMARY

Thrust Chamber Assembly	25 lb
Nozzle Extension	6 lb
Propellant Valve and Tanks	23 lb
Pneumatic Tanks	20 lb
Skin and Rings	85 lb
Struts and Supports	20 lb
Lines and Fittings, Valves, Regulators	30 lb
Nitrogen and Helium	11 lb
Propellants	<u>180 lb</u>
Total	400 lb

APPENDIX C

ULLAGE CHAMBER SCHEMATIC

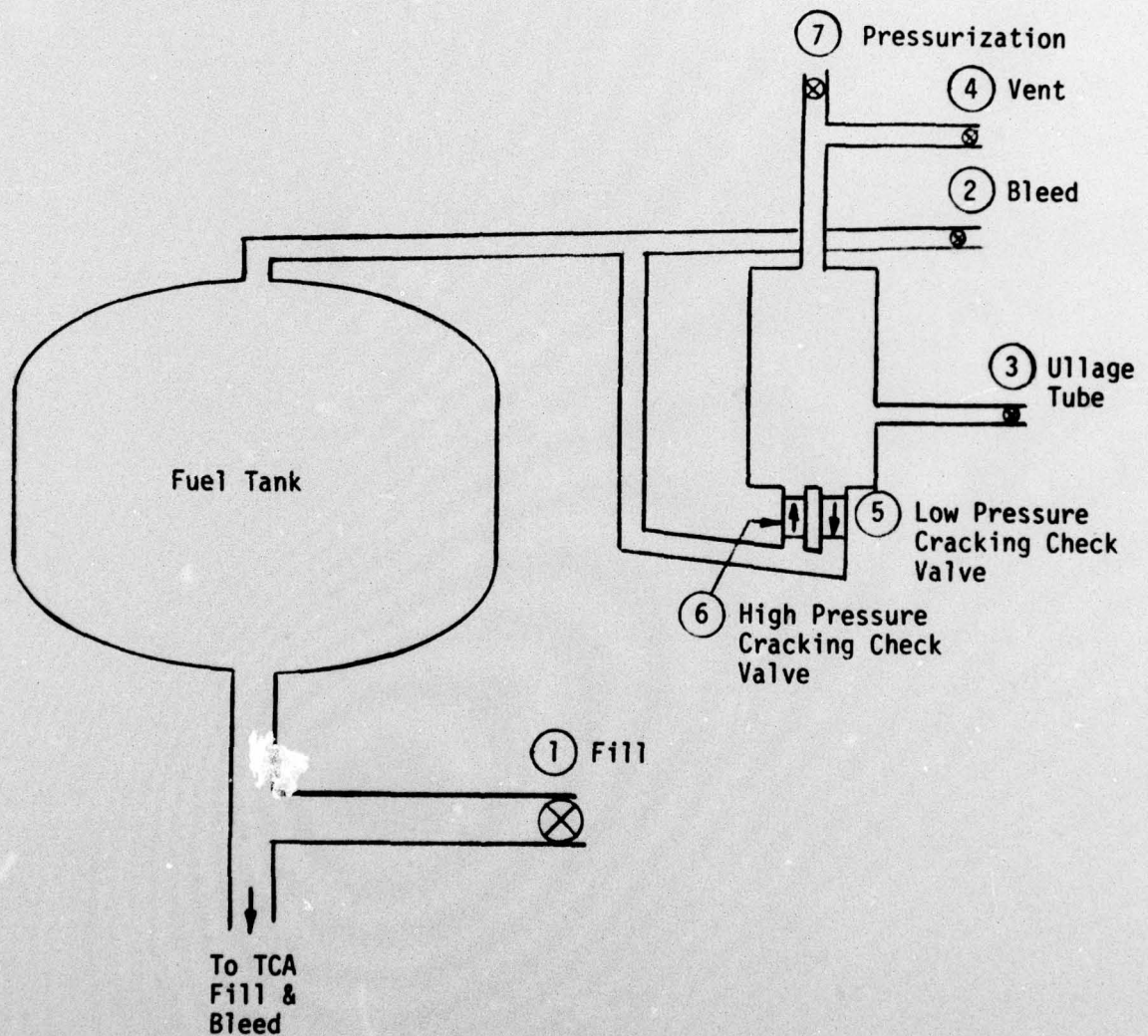

Operation:

- Fill and bleed TCA through (1)
- Fill through (1) to get bleed at (2)
- Fill ullage chamber through (3) with (4) open
- Close (4) and pressurize through (3) and (5) to get bleed at (2)
- Open (4) and drain excess propellant through (3)
- (6) prevents overpressure in tank and TCA
- Pressurize through (7) for start