

AD-A041 729

ROYAL SIGNALS AND RADAR ESTABLISHMENT CHRISTCHURCH (E--ETC F/G 17/2.1  
THE OFFSET FAST FOURIER TRANSFORM (OFFT), (U)  
DEC 76 M TOMLINSON

UNCLASSIFIED

RSRE-76025

DRIC-BR-57174

NL

| of |  
ADA041729



END

DATE  
FILMED  
8 - 77

Report No. 76025

UNLIMITED

BR57174  
Report No. 73025



ROYAL SIGNALS AND RADAR ESTABLISHMENT  
CHISCOMBURY

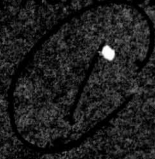

ADA 041729

The effect fast Fourier transform  
(FFT)

by

M. Tomlinson



COPYRIGHT ©  
CONTROLLER HMSO LONDON  
1976

TECHNICAL EXECUTIVE SERVICE  
1976  
Chiscombury Road, Chiscombury, Reading, RG2 9AT

Ministry of Defence, Procurement Executive  
Royal Signals and Radar Establishment, Christchurch

14 RSRE  
Report No. 76025

6 THE OFFSET FAST FOURIER TRANSFORM (OFFT),

by

10 M. TOMLINSON

18 DRIC

19 BR-57174

12 13 p.

Abstract

It is shown that by changing the weighting factors, the fast Fourier Transform (FFT) may be modified to produce a frequency offset. The technique may be used in digital modems to allow a receiver to effectively tune-in to two or more frequencies simultaneously. It may allow improved frequency acquisition in burst transmission systems and improve frequency tracking in conditions where there is rapid rate of change of frequency.

14  
Dec 1976

- i -

409 807

ACCESSION NO.	
REFS	Write Section <input checked="" type="checkbox"/>
DIC	Buff Section <input checked="" type="checkbox"/>
UNANNOUNCED	<input type="checkbox"/>
JUSTIFICATION	
BY	
DISTRIBUTION/AVAILABILITY CODES	
Dist.	AVAIL. and/or SPECIAL
A	

**CONTENTS**

**Page**

1. INTRODUCTION	1
2. THE OFFT ALGORITHM	1
3. GENERAL METHOD FOR ANY FREQUENCY OFFSET	3
4. DISCUSSION	4
5. ACKNOWLEDGMENTS	4
REFERENCES	4
APPENDIX	8

**FIGURES**

1. Conventional arrangement of IF and digital processing
2. Conventional 8-point FFT signal flow diagram
3. Signal flow diagram of 8-point OFFT with half frequency slot offset

THE OFFSET FAST FOURIER TRANSFORM (OFFT)

1. INTRODUCTION

Digital processors using the Fast Fourier Transform algorithm are increasingly being used to implement demodulators in communication systems. A typical system arrangement is shown in the block diagram of Fig 1. The IF filter defines the signal bandwidth and the signal is then mixed down to baseband with nominal low pass filtering prior to analogue to digital conversion and digital processing. In many communication systems the transmitted signal experiences an unknown frequency offset due to local oscillator instabilities, oscillator drift, doppler effects, etc., and small corrections to the frequency tuning have to be done at the receiver. Tuning corrections may be performed by varying the frequency of the local oscillator, but in some applications this is not a satisfactory arrangement as the receiver can only tune to one frequency at a time and part of a message may be lost due to prolonged frequency mistuning.

To illustrate the problem consider a 500 bit/sec 32 level MFSK system, which has a 50 Hz frequency offset so that the receiver is effectively mistuned by 50 Hz. The receiver is implemented using a 128 point FFT analysing a total of 64 frequency slots spaced 100 Hz apart. Each time an MFSK symbol is received a decision is made on the basis of the largest signal in one out of 32 frequency slots. In other words, the receiver is equivalent to a bank of 32 matched filters with centre frequencies which are integral multiples of 100 Hz. Since the signal has a 50 Hz offset the signal will appear in two slots equally thereby producing a 50% chance of error.

As an alternative to correcting the offset by varying the local oscillator, the FFT can be offset itself by half a slot. This offset transform, the OFFT, is equivalent to a bank of filters with centre frequencies which are spaced 100 Hz apart, starting at 50 Hz. Since the frequency offset is usually unknown it is useful if each received symbol is analysed using two FFTs, one OFFT and the other a normal FFT. Detection is done using the results of the FFT which gives the lower symbol error rate, and no part of a message need be lost due to small frequency corrections.

2. THE OFFT ALGORITHM

The conventional discrete Fourier transform (DFT) is usually given by

$$A_{\tau} = \sum_{k=0}^{N-1} x_k e^{-\frac{2\pi j \tau k}{N}} \dots\dots\dots(1)$$

where  $\tau = 0, 1, 2, 3, \dots\dots\dots N-1$

The offset DFT may be defined as

$$P_{\tau} = \sum_{k=0}^{N-1} x_k e^{-\frac{2\pi j k (2\tau+1)}{2N}} \dots\dots\dots(2)$$

where  $\tau = 0, 1, 2, 3, \dots\dots\dots N-1$

In effect the frequency slots are at  $\frac{1}{2}, 1\frac{1}{2}, 2\frac{1}{2} \dots\dots\dots N-\frac{1}{2}$

The OFFT may be derived by decimation in time or in frequency in a manner exactly analogous to that of the FFT.

For example, consider the decimation in time method, where  $P\tau$  is produced from combining the results of two  $N/2$  point transforms.  $P\tau$  is given by:-

$$P\tau = \sum_{k=0}^{\frac{N}{2}-1} X_{2k} e^{-4\pi jk \frac{(2\tau+1)}{2N}} + \sum_{k=0}^{\frac{N}{2}-1} X_{2k+1} e^{-2\pi j \frac{(2k+1)}{2N} (2\tau+1)} \dots\dots\dots(3)$$

The second term may be written as:

$$e^{-2\pi j \frac{(2\tau+1)}{2N}} \cdot \sum_{k=0}^{\frac{N}{2}-1} X_{2k+1} e^{-4\pi jk \frac{(2\tau+1)}{2N}} \dots\dots\dots(4)$$

The weighting term, the first term in equation 4, is similar to the FFT weighting term except that it is

$$e^{-\frac{2\pi j(2\tau+1)}{2N}} \text{ instead of } e^{-\frac{2\pi j}{N}}$$

Continuing the decimation process, each  $N/2$  point transform is split into two  $N/4$  transforms. Expanding the even terms:

$$\sum_{k=0}^{\frac{N}{2}-1} X_{2k} e^{-4\pi jk \frac{(2\tau+1)}{2N}} = \sum_{k=0}^{\frac{N}{4}-1} X_{4k} e^{-8\pi jk \frac{(2\tau+1)}{2N}} + \sum_{k=0}^{\frac{N}{4}-1} X_{4k+2} e^{-4\pi j(2k+1) \frac{(2\tau+1)}{2N}} \dots\dots\dots(5)$$

The odd terms, that is the summation part of equation 4, is split into two  $N/4$  transforms in an identical manner.

As before the second term of equation (5) may be expanded to give the following:

$$e^{\frac{-4\pi j(2\tau+1)}{2N}} \sum_{k=0}^{\frac{N}{4}-1} X_{4k+2} e^{\frac{-8\pi jk(2\tau+1)}{2N}} \dots\dots\dots(6)$$

The weighting term this time is  $e^{\frac{-4\pi j(\tau+\frac{1}{2})}{N}}$  instead of  $e^{\frac{-4\pi j\tau}{N}}$  for the conventional FFT.

If this factorisation process is continued, a stage is reached when  $\frac{N}{2} \log_2 N$  two point transforms are left to be calculated. However, instead of the two points being weighted by the normal  $\pm 1$ , the points are weighted by  $\pm j$ . From the above it is apparent that the weighting factors used in each stage of the OFFT are offset by a term which is exactly half the interval of the weighting factors used in the FFT, at that particular stage of the process. This is illustrated by the example given in the Appendix where the 16 point FFT and OFFT angles for the weighting factors are listed.

To illustrate that the FFT and OFFT differ only in the weighting factors, and may be implemented with the same hardware once the weighting factors are changed, the signal flow diagrams for 8-point transforms are shown in Fig 2 and Fig 3.

### 3. GENERAL METHOD FOR ANY FREQUENCY OFFSET

The above procedure may be used to produce a frequency offset of any amount. If the offset is denoted by  $c$  expression (2) becomes

$$P_\tau = \sum_{k=0}^{N-1} X_k e^{\frac{-2\pi jk(\tau+c)}{N}} \dots\dots\dots(7)$$

and after decimation (4) becomes

$$e^{\frac{-2\pi j(\tau+c)}{N}} \sum_{k=0}^{\frac{N}{2}-1} X_{2k+1} e^{\frac{-4\pi jk(\tau+c)}{N}} \dots\dots\dots(8)$$

and (6) becomes

$$e^{\frac{-4\pi j(\tau+c)}{N}} \sum_{k=0}^{\frac{N}{4}-1} X_{4k+2} e^{\frac{-8\pi jk(\tau+c)}{N}} \dots\dots\dots(9)$$

Working as before, it will be seen that the offset at the last stage is  $c$ , the offset at the penultimate stage is  $2c$ , etc. To illustrate this point, if in the previous example a frequency offset of 10 Hz were required, then the weighting factors used in each stage of the OFFT would be the weighting factors of the FFT offset by 10% of the interval between the weighting factors that are used at that stage of the FFT.

#### 4. DISCUSSION

The hardware necessary to implement the OFFT is identical with that for the FFT except for the weighting factor arrangements. It is a relatively straightforward task to arrange the hardware such that the sampled input waveform is analysed both using an OFFT and FFT on a time-shared basis, so that the receiver is effectively tuned to two or more frequencies at the same time. This feature may be used to improve frequency acquisition in burst transmission systems or it may be usefully employed in systems where frequency changes occur so rapidly that frequency tracking is a severe problem.

Frequency division multiple access (FDMA) systems sometimes have channels spaced at non-integral multiples of one basic frequency. Previously for such systems a digitally implemented receiver using the FFT could not be used, but using the OFFT as well as the FFT, a time shared FDM receiver could demodulate several FDM channels simultaneously.

#### 5. ACKNOWLEDGMENTS

The author would like to thank his colleagues for helpful discussions, in particular Mr R L Harris and Dr B H Davies.

#### REFERENCES

1. "The Fast Fourier Transform" Cochran et al Proc IEEE October 1967.

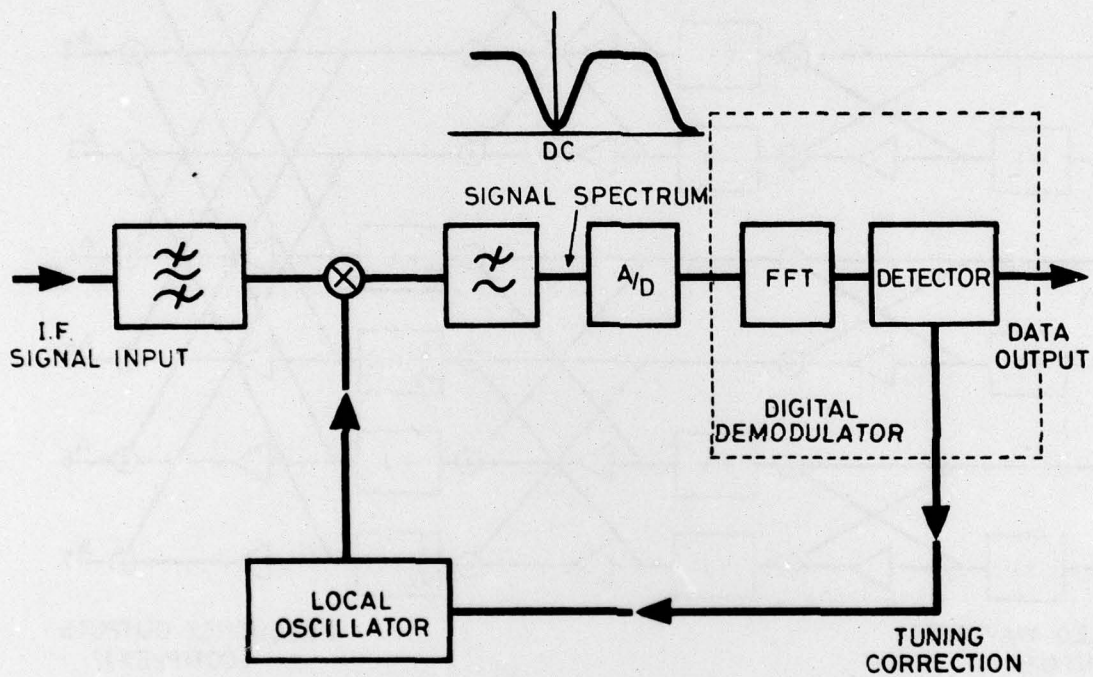
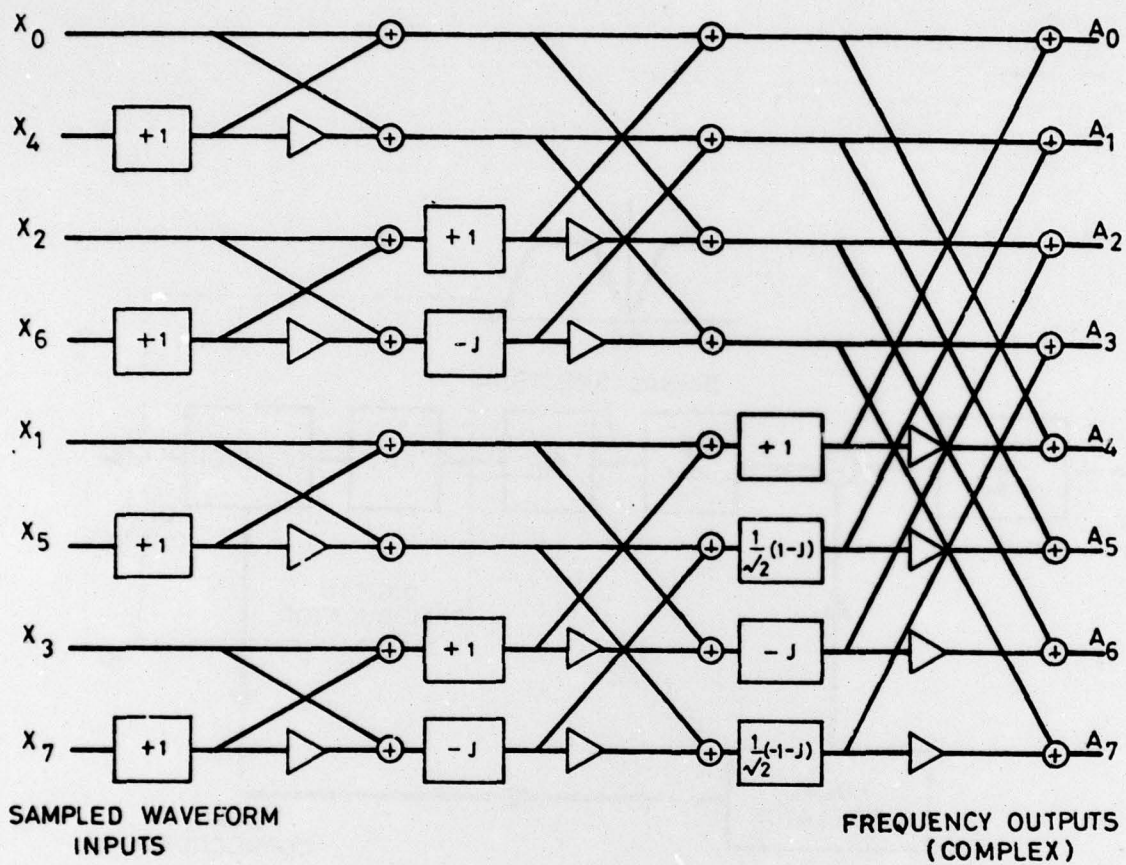

FIG.1 CONVENTIONAL ARRANGEMENT OF IF AND DIGITAL PROCESSING



KEY:-  $\boxed{k}$  - MULTIPLY BY  $k$ .  $\triangleleft$  - INVERT.  $\oplus$  - ADD INPUTS.

FIG. 2 CONVENTIONAL 8-POINT FFT SIGNAL FLOW DIAGRAM

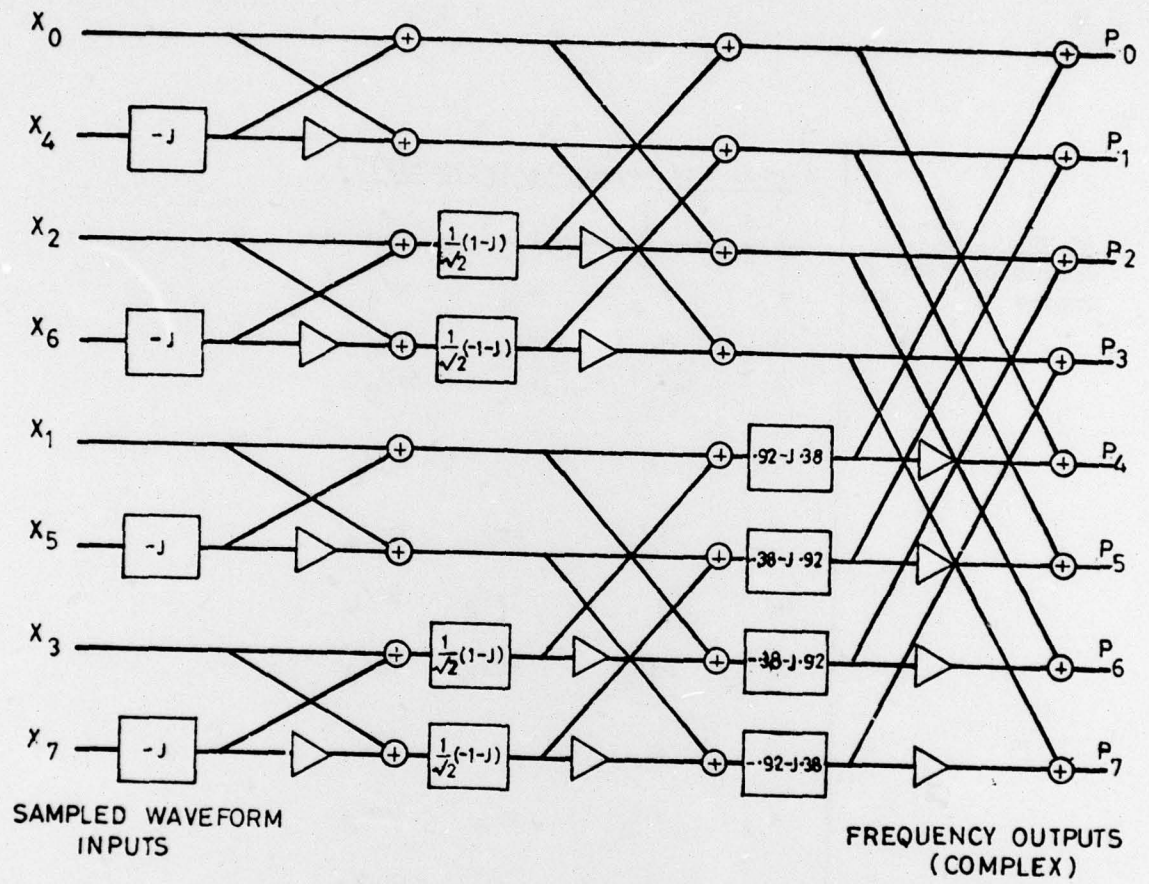

FIG. 3 SIGNAL FLOW DIAGRAM OF 8-POINT FFT WITH HALF FREQUENCY SLOT OFFSET

APPENDIX

The angles for the weighting factors for the 16 point FFT and OFFT are listed below. Where the angle is say  $\phi$ , the weighting factor is given by  $e^{j\phi}$ .

Stage of FFT Weighting Factor Angles	Angles for Weighting Factors (FFT)			
	0	1	2	3
0	0	0	0	0
$\pi$	$\pi/2$	$\pi/4$	$\pi/8$	
0	$\pi$	$\pi/2$	$\pi/4$	
$\pi$	$3\pi/2$	$3\pi/4$	$3\pi/8$	
0	0	$\pi$	$\pi/2$	
$\pi$	$\pi/2$	$5\pi/4$	$5\pi/8$	
0	$\pi$	$3\pi/2$	$3\pi/4$	
$\pi$	$3\pi/2$	$7\pi/4$	$7\pi/8$	
0	0	0	$\pi$	
$\pi$	$\pi/2$	$\pi/4$	$9\pi/8$	
0	$\pi$	$\pi/2$	$5\pi/4$	
$\pi$	$3\pi/2$	$3\pi/4$	$11\pi/8$	
0	0	$\pi$	$3\pi/2$	
$\pi$	$\pi/2$	$5\pi/4$	$13\pi/8$	
0	$\pi$	$3\pi/2$	$7\pi/4$	
$\pi$	$3\pi/2$	$7\pi/4$	$15\pi/8$	

Angles for Weighting Factors (OFFT)

Stage of OFFT	0	1	2	3
Angles	$\pi/2$	$\pi/4$	$\pi/8$	$\pi/16$
	$3\pi/2$	$3\pi/4$	$3\pi/8$	$3\pi/16$
	$\pi/2$	$5\pi/4$	$5\pi/8$	$5\pi/16$
	$3\pi/2$	$7\pi/4$	$7\pi/8$	$7\pi/16$
	$\pi/2$	$\pi/4$	$9\pi/8$	$9\pi/16$
	$3\pi/2$	$3\pi/4$	$11\pi/8$	$11\pi/16$
	$\pi/2$	$5\pi/4$	$13\pi/8$	$13\pi/16$
	$3\pi/2$	$7\pi/4$	$15\pi/8$	$15\pi/16$
	$\pi/2$	$\pi/4$	$\pi/8$	$17\pi/16$
	$3\pi/2$	$3\pi/4$	$3\pi/8$	$19\pi/16$
	$\pi/2$	$5\pi/4$	$5\pi/8$	$21\pi/16$
	$3\pi/2$	$7\pi/4$	$7\pi/8$	$23\pi/16$
	$\pi/2$	$\pi/4$	$9\pi/8$	$25\pi/16$
	$3\pi/2$	$3\pi/4$	$11\pi/8$	$27\pi/16$
	$\pi/2$	$5\pi/4$	$13\pi/8$	$29\pi/16$
	$3\pi/2$	$7\pi/4$	$15\pi/8$	$31\pi/16$

DETACHABLE ABSTRACT CARDS

When a card is taken out, complete the appropriate space on the inside back cover. These cards are subject to the same security regulations as the parent document.

MOD(PE), RSRE (C)

Report No 76025

THE OFFSET FAST FOURIER TRANSFORM (OFFT)

by

M TOMLINSON

Abstract

It is shown that by changing the weighting factors, the Fast Fourier Transform (FFT) may be modified to produce a frequency offset. The technique may be used in digital modems to allow a receiver to effectively tune-in to two or more frequencies simultaneously. It may allow improved frequency acquisition in burst transmission systems and improve frequency tracking in conditions where there is rapid rate of change of frequency.

DECEMBER 1976

MOD(PE), RSRE (C)

Report No 76025

THE OFFSET FAST FOURIER TRANSFORM (OFFT)

by

M TOMLINSON

Abstract

It is shown that by changing the weighting factors, the Fast Fourier Transform (FFT) may be modified to produce a frequency offset. The technique may be used in digital modems to allow a receiver to effectively tune-in to two or more frequencies simultaneously. It may allow improved frequency acquisition in burst transmission systems and improve frequency tracking in conditions where there is rapid rate of change of frequency.

DECEMBER 1976

MOD(PE), RSRE (C)

Report No 76025

THE OFFSET FAST FOURIER TRANSFORM (OFFT)

by

M TOMLINSON

Abstract

It is shown that by changing the weighting factors, the Fast Fourier Transform (FFT) may be modified to produce a frequency offset. The technique may be used in digital modems to allow a receiver to effectively tune-in to two or more frequencies simultaneously. It may allow improved frequency acquisition in burst transmission systems and improve frequency tracking in conditions where there is rapid rate of change of frequency.

DECEMBER 1976