

AD-A042 043

RAND CORP SANTA MONICA CALIF
ADVANCED COMPOSITES: ELECTROMAGNETIC PROPERTIES, VULNERABILITIE--ETC(U)
MAY 77. A L HIEBERT
R-1979-AF

F/G 11/4

UNCLASSIFIED

NL

1 OF 1
ADAO42043

1



END

DATE
FILMED
8 - 77

AD A 042043

12
NW

R-1979-AF
May 1977

Advanced Composites: Electromagnetic Properties, Vulnerabilities, and Protective Measures

A. L. Hiebert

A Project AIR FORCE report
prepared for the
United States Air Force

DDC
RECEIVED
JUL 27 1977
REGISTRY
F

AD No. _____
DDC FILE COPY

Rand
SANTA MONICA, CA 90406

DISTRIBUTION STATEMENT A
Approved for public release;
Distribution Unlimited

The research reported here was sponsored by the Directorate of Operational Requirements, Deputy Chief of Staff/Research and Development, Hq. USAF under Contract F49620-77-C-0023. The United States Government is authorized to reproduce and distribute reprints for governmental purposes notwithstanding any copyright notation hereon.

Reports of The Rand Corporation do not necessarily reflect the opinions or policies of the sponsors of Rand research.

UNCLASSIFIED

SECURITY CLASSIFICATION OF THIS PAGE (When Data Entered)

REPORT DOCUMENTATION PAGE		READ INSTRUCTIONS BEFORE COMPLETING FORM
1. REPORT NUMBER R-1979-AF ✓	2. GOVT ACCESSION NO.	3. RECIPIENT'S CATALOG NUMBER
4. TITLE (and Subtitle) Advanced Composites: Electromagnetic Properties, Vulnerabilities, and Protective Measures.	5. TYPE OF REPORT & PERIOD COVERED 9 Interim rept.,	
7. AUTHOR(s) A. L./Hiebert	8. CONTRACT OR GRANT NUMBER(s) 15 F49620-77-C-0023 ✓	
9. PERFORMING ORGANIZATION NAME AND ADDRESS The Rand Corporation ✓ 1700 Main Street Santa Monica, Ca. 90406	10. PROGRAM ELEMENT, PROJECT, TASK AREA & WORK UNIT NUMBERS	
11. CONTROLLING OFFICE NAME AND ADDRESS Project AIR FORCE Office (AF/RDQA) Directorate of Operational Requirements Hq USAF, Washington, D.C. 20330	12. REPORT DATE 11 May 1977	
14. MONITORING AGENCY NAME & ADDRESS (if different from Controlling Office) 12 54p.	13. NUMBER OF PAGES 54	
	15. SECURITY CLASS. (of this report) UNCLASSIFIED	
16. DISTRIBUTION STATEMENT (of this Report) Security Restricted		
17. DISTRIBUTION STATEMENT (of the abstract entered in Block 20, if different from Report) No restrictions		
18. SUPPLEMENTARY NOTES		
19. KEY WORDS (Continue on reverse side if necessary and identify by block number) Composite Materials Electromagnetic Properties Electromagnetic Shielding		
20. ABSTRACT (Continue on reverse side if necessary and identify by block number) see reverse side		

296600

18

UNCLASSIFIED

SECURITY CLASSIFICATION OF THIS PAGE (When Data Entered)

↓

This report outlines and discusses a measurement and analysis program for assessing the electromagnetic (EM) properties and vulnerabilities of, and protective measures for, advanced composite materials used in the design and construction of aerospace vehicles. The main objective is to suggest areas for investigation and the kind of information needed for the compilation of a data base. Six areas of investigation are discussed: advanced composite materials, structural composition, and fabrication; potential use of composite materials and structures; fundamental EM parameters of advanced composites; energy sources and environments of EM hazards; EM vulnerabilities and shielding effectiveness criteria; protective measures. Examples of measurement techniques and/or essential data are given for each. A suggested format for cataloging the information is included. Refs. (DGS) ↑

UNCLASSIFIED

R-1979-AF
May 1977

Advanced Composites: Electromagnetic Properties, Vulnerabilities, and Protective Measures

A. L. Hiebert

A Project AIR FORCE report
prepared for the
United States Air Force

ACCESSION for	
NTIS	Write Section <input checked="" type="checkbox"/>
DDC	Buff Section <input type="checkbox"/>
UNANNOUNCED	<input type="checkbox"/>
JUSTIFICATION	
BY	
DISTRIBUTION/AVAILABILITY CODES	
Dist.	AvAIL. and/or SPeCIAL
A	



PREFACE

The use of advanced composite materials and structures--as well as novel physical shapes--may significantly change the electromagnetic (EM) characteristics of future aerospace vehicles. Opportunities will be offered for reducing costs and structural weight, but there will be accompanying penalties; such materials exhibit substantial variation in intrinsic EM parameters and lack the shielding qualities of conventional metal structures. This report attempts to provide a comprehensive overview of many areas of concern and of some proposed programs to address these areas. It also outlines assessment procedures for deriving a more definitive knowledge of the EM implications of the use of composites.

The Rand Corporation, under Project AIR FORCE (formerly Project RAND), is conducting technical surveys and assessments of the EM properties and vulnerabilities of, and protective measures for, advanced composites. This activity is planned as part of a cooperative program with industry--as producers, users, and sources of the data--and with government agencies concerned with applications and the EM properties of advanced composites. Government programs and contracts with industry and universities will be included in the assessment. The objective is to assemble a technical data base for composites on (a) current and projected composition and fabrication, (b) current and potential utilization, (c) fundamental EM parameters, (d) definitions and descriptions of energy sources and environments contributing to EM hazards, (e) definitions of EM vulnerabilities and shielding effectiveness criteria, and (f) protective measures related to specific hazards and vulnerabilities.

This report describes the kinds of information needed, solicits inputs, and suggests a format for submitting the information to Rand for assessment. A report (RADC-TR-76-206) published by the Air Force Rome Air Development Center in July 1976, contains descriptions of measurement techniques proposed for use and evaluation in obtaining the EM parameters of composites where additional measurements are required.

Lieutenant Colonel J. R. Brown (SAMSO/AWST), Dr. John Corbin of the Flight Dynamics Laboratory (AFFDL/FES), and Dr. Roy Stratton of Rome Air Development Center (RADC/RBCT) are serving as Air Force points of contact for this work. However, acknowledgment of the interest or participation of individuals or Air Force agencies mentioned in this report should not be construed as endorsement by the Air Force of the programs proposed here.

These reports, together with the subsequent analysis, should be useful to industrial producers, structural and EM design engineers, and government agencies concerned with applications of advanced composites.

The work documented in this report was performed under the Project AIR FORCE "System Vulnerability" research project.

SUMMARY

This report outlines and discusses a measurement and analysis program for assessing the electromagnetic (EM) properties and vulnerabilities of, and protective measures for, advanced composite materials that are being used, and being developed for use, in the design and construction of aerospace vehicles. The main purpose of the report is to suggest areas of investigation and the kinds of data required to compile a technical data base to accomplish this assessment.

Instrumentation and techniques are needed that will provide some standard procedures for measuring and analyzing such fundamental EM parameters as conductivity, permittivity, permeability, shielding properties, and vulnerability to EM hazards and environments. Once we understand these important areas, we can design protective measures. A number of measurement techniques and procedures are suggested in this study.

Our findings to date show that, compared with metals, nonmetallic composites have low conductivity and large variations in EM parameters; these are due to wide differences in materials, manufacturers' fabrication techniques, and structural composition. Whenever nonmetallic composites are used or substituted for metals, it is essential that the inherent EM properties be identified, analyzed, re-engineered, and re-established to meet EM functions and specifications as required. These requirements should be added to Air Force in-house R&D programs and specified in contracts with industry.

Several workshops on the EM hazards associated with advanced composite airframe structures were jointly organized by AFFDL/FB, AFFDL/FES, AFSC/DL, and Rand, with the participation of cognizant Air Force agencies and personnel, and were conducted during November 1974, February 1975, and March 1976 at Wright-Patterson Air Force Base. A comprehensive "roadmap" was compiled of the activities required to resolve problems in onboard electrical and electronic systems caused by the extensive use of nonmetallic composite materials for airframe structures. Another Air Force roadmap, detailing the development and

applications of advanced composites for space and missile systems, is being prepared by SAMSO and AFWAL. A roadmap of the applications of composites for ground structures and enclosures, including the EM implications, should be compiled.

New and/or additional protective EM shielding will be required on aerospace vehicles, on communications and electronic (C&E) equipment, and on sensitive digital avionics equipments and components to protect them from hazards such as electromagnetic pulse (EMP), lightning, static electricity, electromagnetic interference (EMI), and other extraneous EM energy. Electrical integrity and continuity for grounding, bonding, and power returns will require attention. The several orders of magnitude of EM shielding attenuation and electrical continuity provided by metal housings, enclosures, and structures may be substantially reduced by using composites.

A program to conduct surveys and measurements, and to assess analytic technologies within industry and cognizant Department of Defense agencies, is underway (sponsored by Rand and coordinated with the Air Force) to determine the fundamental EM parameters, define EM hazards and vulnerabilities, and design protective measures for advanced composites. A suggestion made in this report for a program on "Engineering Solutions for Protective Measures" is being implemented by the Air Force to solve current problems and to establish EM hazard/environmental testing capabilities.

Other, extensive programs sponsored by the Air Force on the EM hazards and vulnerability of advanced composites are referenced throughout this study.

ACKNOWLEDGMENTS

Air Force personnel who have provided assistance to this project include R. B. Baird, C. S. Porter, and Major F. R. Wentland of Hq USAF; R. C. Beavin, Lt. Col. T. F. Ferguson, and B. A. Kulp of the Air Force Systems Command; P. A. Parmley, J. K. Ramage, L. Kelly, G. A. DuBro, D. G. Kim, C. F. Patterson, and V. Mangold of the Air Force Flight Dynamics Laboratory; R. M. Stanton of the Air Force Materials Laboratory; W. F. Bahret and L. E. Carter of the Air Force Avionics Laboratory; C. E. Seth of the Aeronautical Systems Division; Paul Propp of SAMSO (Materials Laboratory); J. Scherer and K. R. Siarkiewicz of Rome Air Development Center; and members of the Air Force Workshops on EM Hazards Associated with Advanced Composite Structures, sponsored by the Flight Dynamics Laboratory at Wright-Patterson Air Force Base.

E. C. Kendall, M. F. Amateau, and W. R. McDonald of the Aerospace Corporation, and J. L. Allen of the University of Southern Florida have also provided valuable inputs.

Special acknowledgment is due Lt. Col. G. G. Leigh and J. C. Corbin of the Air Force Flight Dynamics Laboratory; R. M. Neff of the Air Force Materials Laboratory; R. F. Stratton of Rome Air Development Center; Lt. Col. J. R. Brown and Lt. Col. H. L. Staub of SAMSO; and E. Bedrosian and G. K. Smith of The Rand Corporation for their support and critical review of the manuscript.

Acknowledgment of the contributions made by the above individuals does not necessarily imply their endorsement of the opinions and policies expressed in this report.

Dorothy Stewart edited the manuscript and greatly improved its readability.

CONTENTS

PREFACE	iii
SUMMARY	v
ACKNOWLEDGMENTS	vii
GLOSSARY	xi
Section	
I. INTRODUCTION	1
II. PROPOSED AREAS OF INVESTIGATION	3
III. A MEASUREMENT AND ANALYSIS PROGRAM	4
Advanced Composite Materials, Structural Composition, and Fabrication	5
Potential Uses of Composite Materials and Structures	10
Fundamental EM Parameters of Advanced Composites	14
Energy Sources and Environments Contributing to EM Hazards	16
EM Vulnerabilities and Shielding Effectiveness Criteria	25
Protective Measures	28
IV. THE MEASUREMENT AND ANALYSIS DATA BASE: A SUGGESTED FORMAT	32
V. SOME CONCLUDING SUGGESTIONS	34
APPENDIX	35
REFERENCES	39

PRECEDING PAGE BLANK-NOT FILMED

GLOSSARY

AFAL	Air Force Avionics Laboratory
AFAPL	Air Force Aero Propulsion Laboratory
AFFDL	Air Force Flight Dynamics Laboratory
AFFTD	Air Force Foreign Technology Division
AFML	Air Force Materials Laboratory
AFSC	Air Force Systems Command
AFWAL	Air Force Wright Aeronautical Laboratory
AFWL	Air Force Weapons Laboratory
ASD	Aeronautical Systems Division
C&E	Communications and electronics
CW	Continuous wave
EM	Electromagnetic
EMC	Electromagnetic compatibility
EMI	Electromagnetic interference
EMP	Electromagnetic pulse
ex-situ	Outside vacuo
IAP	Intrasystem Analysis Program
in-situ	Inside vacuo
IR	Infrared
NASA	National Aeronautical and Space Agency
P-static	Precipitation static
RADC	Rome Air Development Center
RF	Radio frequency
RPV	Remotely piloted vehicle
SAMSO	Space & Missile Systems Organization
TEM cell	Transverse electromagnetic transmission cell

I. INTRODUCTION

The use of advanced composite materials in the design and construction of aerospace vehicles is increasing and is expected to continue in view of their potential cost savings, lighter weight, strength and stiffness characteristics. Composite materials also offer a number of advantages in the manufacture and assembly of aerospace vehicles. However, experience has shown that composites vary significantly both in their electromagnetic (EM) properties and in their vulnerabilities to EM hazards associated with aerospace systems and components. Thus far, interest has primarily centered on their mechanical/structural features; less emphasis has been placed on their EM properties, which differ substantially from those of conventional metals. Information on EM properties is generally not provided by the manufacturer, and measurements by the user (the aerospace industry) are often sporadic and exhibit large variations in technique and data accuracy.

The EM performance of advanced composites may vary extensively because of the wide variety of materials used, as well as the manufacturing techniques involved, i.e., reinforcements, matrices, lay-ups, etc., all of which can have a direct impact on safety and mission performance.

Established design specifications and practices are based on metal structures and enclosures, which provide substantial EM shielding, electrical integrity, and grounding. When composites are used, however, additional EM shielding must be provided on sensitive digital communication/electronic equipments and components to protect them against radio frequencies (RF), lightning, static electricity, electromagnetic interference (EMI), radar pulses, electromagnetic pulses (EMP), and EM hazards in space environments.

To determine the vulnerabilities to EM hazards that are introduced when composite materials are used in place of metals, or in combination with metals, and to establish a technical data base for EM parameters, we must first identify and define the physical properties of composites and relate them to the potential uses of these materials. Advanced composites are man-made combinations of two or more chemically distinct

elements (materials) separated by distinct interfaces; they are created to obtain structural properties unachievable by the elements alone. The more common and extensively used advanced organic-matrix composites are the boron-epoxy, graphite-epoxy, and graphite-Kevlar hybrid-epoxy materials. Metallic-base composites, such as graphite-aluminum and boron-aluminum, are also being developed, although they are still costly and are only applicable to highly specialized uses. The EM properties of new composites being developed will need to be analyzed.

The Rand Corporation is conducting a comprehensive study under Project AIR FORCE to assess and analyze measurements of the EM properties of advanced composites. This study will examine the characteristics of composites that affect the EM properties (such as susceptibility to moisture absorption, thermal coefficients, erosion, etc.), explore their use potential, shielding effectiveness, and vulnerabilities to EM hazards, and determine what protective measures can be taken. This report attempts to provide a comprehensive overview of many areas of concern and of some proposed programs to address these areas. It also outlines assessment procedures for deriving a more definitive knowledge of the use of composites.

The planned procedure for the overall study is (1) to conduct interviews/surveys in industry concerned with the development and production of advanced composites; (2) to determine the potential uses of composites by aerospace defense contractors; and (3) to assess the EM measurement and analysis capabilities of industry, universities, and government agencies in measuring and analyzing the EM data listed.

The results of this effort should help us to define the more significant problems encountered in the use of advanced composites and to establish priorities for their solution. They should also enable us to identify technical data sources and to develop a scientific/engineering data base for designing specifications and programs for the measurement and analysis of protective measures.

A report on the data compiled from this measurement and analysis program is planned, and will be made available to government agencies and industries concerned with the EM implications associated with advanced composites.

II. PROPOSED AREAS OF INVESTIGATION

Some proposed areas of investigation for the measurement and analysis of the electromagnetic properties and vulnerabilities of, and protective measures for, advanced composite materials and structures are listed below:

- o Advanced composite materials, structural composition, and fabrication.
- o Potential use of composite materials and structures.
- o Fundamental EM parameters of advanced composites.
- o Energy sources and environments of EM hazards.
- o EM vulnerabilities and shielding effectiveness criteria.
- o Protective measures.

These areas are discussed in Sec. III. A suggested format for describing and documenting the information needed to compile a technical data base on composite materials is given in Sec. IV.

Although this report reviews and discusses some of the work that has been done to date on determining the EM implications of advanced composite materials and structures, the main emphasis is on what still needs to be done, especially in terms of assessing (1) the current and potential uses of advanced composites and structures; (2) the characteristics, structural composition, and fabrication of composite materials and their effect on EM parameters; (3) the overall implications and problems related to the use of nonmetallic composites as replacements for metals or in combination with metals; and (4) technologies for providing composite materials with the required EM functions and protective measures commonly associated with metals.

III. A MEASUREMENT AND ANALYSIS PROGRAM

In this section we will outline a program for measuring and analyzing the EM properties of advanced composite materials and structures and discuss the broad, interdisciplinary efforts required to accomplish it. The proposed objectives of the program are (1) to survey the characteristics, structural composition, and fabrication of advanced composite materials and their impact on EM parameters; (2) to assess the potential uses of composite materials and structures; (3) to define and acquire data on the fundamental EM parameters of advanced composite materials and structures by designing a combined computer model and analysis program and by employing measurement techniques; (4) to define and describe energy sources and environments contributing to EM hazards; (5) to determine and assess EM vulnerabilities and shielding effectiveness criteria; and (6) to design protective measures. Each of these objectives will be discussed in separate subsections below.

Several workshops on EM hazards associated with composite structures were jointly organized by AFFDL/FB, AFFDL/FES, AFSC/DL, and Rand, with the participation of cognizant Air Force agencies and personnel, and were conducted in November 1974, February 1975, and March 1976 at Wright-Patterson Air Force Base. The objective was to construct a "roadmap" of the activities that are required to resolve problems in onboard electrical or electronic systems caused by the extensive use of nonmetallic composite materials for airframe structures.

Preliminary planning documents and considerable follow-on work have been done by AFFDL and ASD, including inputs provided by AFSC, AFWL, ASD, AFAL, AFML, AFAPL, RADC, and Rand. Composite planning activities have been conducted to design and develop a coordinated Air Force plan in this field, incorporating results of the previous work.

The design and coordination of an overall DoD program will be difficult in view of the large number of agencies and technologies involved. The projects proposed in this report and in the Air Force workshop planning documents are considered essential to the overall program. Thus, to avoid duplication of effort and to maximize the dissemination and

application of results, a procedure to evaluate and distribute the data is needed. Interagency participation is necessary to develop such a procedure. Measurement and test programs have already documented some of the EM properties, shielding effectiveness, and other elements of composites.

ADVANCED COMPOSITE MATERIALS, STRUCTURAL COMPOSITION, AND FABRICATION

The proposed objectives are to assess (a) the characteristics^{*} and properties of advanced composite materials, (b) their structural composition and fabrication, and (c) their impact on EM parameters. The essential data include:

1. Characteristics and properties of composite materials available and in development.[†]
 - a. Characteristics of matrix materials in composites, e.g., metal, organic, ceramic, etc.
 - b. Characteristics of fiber materials in composites, e.g., carbon, boron, silicon carbide, silicon nitride, aluminum oxide, quartz, glass, etc.
 - c. Characteristics of the interface between the fiber and matrix.
 - d. Properties of composites that may affect EM parameters:
 - o Formability and fabricability.
 - o Joining: mechanical fastening, diffusion bonding, brazing, adhesive bonding, welding.
 - o Environmental resistance: temperature range, chemicals, moisture, aggressive liquids, permeability, rain erosion, corrosion, resistance, thermal expansion.
 - o Mechanical properties affecting fundamental EM parameters.
2. Structural composition and fabrication of composite materials.
 - a. Structural composition, geometries of lay-ups, fibers, and shapes (i.e., multilayer, hybrid designs; fiber angles in

^{*} See Refs. 1-6.

[†] The characteristics of the composite materials listed here are direction-dependent due to the essential anisotropy of the ultimate structural unit, i.e., a fiber exhibiting highly anisotropic properties embedded in a matrix.

- tapes: number and geometric angles of tapes in finished composites).
- b. Geometric-physical volume of fibers and matrix in finished composites. (Specific structural applications dictate unique ply build-ups and anisotropic property development.)
 - c. Examples of advanced composite fabrication and lay-ups:
 - o Single-ply unidirectional prepreg lamina.
 - o Single-ply woven prepreg lamina (square weave or satin weave).
 - o Multiple-ply laminates (strips or panels) (common lay-up angles $[0^\circ, 90^\circ]_S$, $[0^\circ, \pm 45^\circ, 90^\circ]_S$, $[0^\circ, \pm 60^\circ]_S$; S = symmetrical).
 - o Multiple-ply laminates (combinations of various angles).
 - o Hybrid single-ply prepreg lamina (unidirectional or woven).
 - o Hybrid multiple-ply laminates (unidirectional, lay-up angles $[0^\circ, 90^\circ]_S$, $[0^\circ, \pm 45^\circ, 90^\circ]_S$, $[0^\circ, \pm 60^\circ]_S$).
 - o Hybrid multiple-ply woven laminates (common weave angles $[0^\circ, 90^\circ]_S$, $[0^\circ, \pm 45^\circ, 90^\circ]_S$, $[0^\circ, \pm 60^\circ]_S$).
 - o Hybrid multiple-ply unidirectional fibers and woven laminates.
 - o Chopped fiber molding.
 - o Multidimensional composites (common weave).
 - d. Solid materials and structures versus honeycomb and other forms.
3. Effect of coatings applied to composite materials and structures on EM parameters.
 4. Effect of repairs to composites on EM parameters and requirements.
 - a. Composite materials (laminates) only.
 - b. Composites over or adjoining metals.
 - c. Metals over or adjoining composites.
 - d. Metals intermittent with composites.
 - e. Hybrid composites.
 - f. Metal matrix composites.

- g. Adhesive fasteners.
 - h. Aging and fatigue.
5. Curing and control parameters by composite manufacturers that affect EM properties.

In order to design the analytic or measurement technology needed to acquire data on fundamental EM parameters of advanced composites, one must understand the physical characteristics and fabrication of structures. Detailed technical data are needed on constituent materials, structural composition, and fabrication, on quality control practices, and on the principal mechanical properties that affect the EM parameters. Changes in EM parameters resulting from moisture absorption of the fibers, stress, vibration, and other extraneous processes will need to be determined.

Structural composite materials are defined as a combination of two or more materials so that the structural properties of the composite are superior to those of either component. A simple composite material, shown in Fig. 1, contains fibers that are laid up separately and

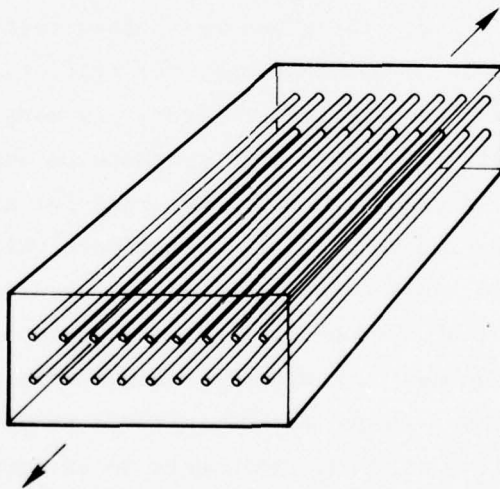

Fig. 1--Structural composite materials

parallel, in uniaxial alignment, and are embedded in the matrix. Complex structures contain multilayers of fibers having different fiber orientations, and therefore multiple-laminate geometric angles.

A principal factor in the rapidly growing use of composites is that they permit designs of nearly unlimited variety in composition and use. Determining the EM properties may be more difficult and more important when nonmetallic or combinations of nonmetallic and metallic materials are used as reinforcements (fibers) and in the matrix. The multidirectional lay-ups of the fibers also make EM measurements difficult.

As shown in Fig. 1, composite materials are made up of the fiber (the reinforcement) and the matrix (the glue), which is generally composed of a form of organic resin or metal-base material. The fibers are manufactured from the materials listed in Table 1, graphite being the most commonly used reinforcement. It should be emphasized that in nonmetallic composite materials, the matrix is a dielectric and any current must flow through its fibers. In composite materials consisting of graphite fibers, the fibers are thin (7 to 10 μ in diameter) and the resistivity is sufficiently high to cause heating, resulting in structural damage and arcing at high current levels.

Composites are not new; fiberglass-reinforced resins have been available since the early 1940s. However, the stiffer, high-modulus, low-density fibers, such as graphite or boron, are more recent developments. The resin matrix reinforced with graphite or boron fibers is an attractive structural and engineering material for aircraft, spacecraft, missiles, and enclosures. Continuous fibers reinforced with metal-matrix composites, such as boron-aluminum, were developed in the mid-1960s. More recent developments in metal composites⁽⁶⁾ reportedly offer a series of advantages over organic-resin matrix composites in specialized applications. These include improved properties at higher temperature, formability, welding, resistance to environments, moisture, etc., and electrical and thermal conductivity.

With the introduction of metal composites, the problem of deriving analytic-measurement technologies for determining the EM properties may be reduced. Future development of metal composites may provide a means

Table 1
COMPOSITES^a

Matrix	Reinforcement
Metal	Boron--tungsten core
Aluminum	Boron--carbon core
Titanium	Borsic
Magnesium	Graphite--high strength
Copper	Graphite--high modulus
Lead	Graphite--high strain
Zinc	Graphite--ultra-high modulus
Nickel	Silicon carbide
Organic	Silicon nitride
Phenolic	Sapphire
Epoxy	Beryllium
Polyimide	E-glass
Polybenzimidazole	S-glass
Polyheterocyclic polymer	Kevlar
Polysulfones	Tungsten
	Quartz
	FB fiber (polycrystalline alumina)
Directionally solidified eutectics	
Nickel	Nickel aluminide (Ni ₃ Al)
Nickel	Nickel niobide (Ni ₃ Nb)
Cobalt	Cobalt niobide (Co ₃ Nb)
Tantalum	Tantalum carbide (TaC)

^aThe characteristics of the composite materials listed here are generally direction-dependent due to the essential anisotropy of the ultimate structural unit, i.e., a fiber exhibiting highly anisotropic properties embedded in a matrix.

for achieving both the desired EM properties and the structural properties within the composites. This is one essential objective of this investigation.

The more common and extensively used advanced composites are the organic-matrix graphite-epoxy, and graphite-Kevlar hybrid-epoxy materials. The recently developed metal-matrix composite--boron-aluminum--is being increasingly used, but is expensive. Graphite-aluminum composites and the directionally solidified eutectics (high-temperature composites) are being developed for highly specialized use.

Although the composites are listed in Table 1 principally for information, a knowledge of the form and characteristics of the more common ones will be necessary in order to determine applications and added requirements that will control EM hazards and provide electrical integrity where nonconductive composites are used.

POTENTIAL USES OF COMPOSITE MATERIALS AND STRUCTURES

The proposed objectives are (a) to determine the current and potential use of advanced composites for internal and external structures in weapon delivery platforms and aerospace vehicles, and (b) to outline a program that will lead to design standards for integrating new composite materials and metal-base structures to ensure EM integrity and the survivability of vehicles and internal/external communications and electronic (C&E) systems in EM environments.

A proposed assessment of the potential uses of composite materials and structures and their impact on EM requirements* is outlined below:

1. Application of advanced composites in current weapon systems acquisition.
 - a. Types of aerospace vehicles.
 - b. Types of composites used or scheduled for use.
 - c. Dimensions and volume of composites and forms of structures.
 - d. C&E components and systems associated with, or affected by, advanced composite structures.
 - e. EM components and systems associated with, or affected by, advanced composite structures.
2. Predicted and potential uses of composite materials.
 - a. Types of aerospace vehicles in which advanced composites will be used extensively.
 - b. Application of hybrid/tailored structural composition of advanced composites to associated aerospace vehicles.
 - c. Dimensions and forms of structures.

* See Refs. 7-21.

- d. Predicted C&E component/systems requirements.
- e. Predicted EM components.
- 3. Identification and assessment of preferred materials for application to aircraft, missiles, spacecraft, and various aerospace vehicle designs.
- 4. Design and analysis of techniques for integrating advanced composite materials and metal-base structures that will ensure EM integrity and the survivability of aerospace vehicles and C&E systems in EM environments.
- 5. Survey of future developments of advanced composites and applications.

Table 2 simply illustrates the growing trend in the use of composite materials. Some forms of composites, such as fiberglass, have

Table 2

EXAMPLES OF CURRENT AND POTENTIAL USES OF ADVANCED COMPOSITES

Vehicles and Structures	Components
Sections of F-15, F-16, F-18, B-1	Space equipment and antenna
Advanced design composite aircraft	Reflectors
RPVs	Waveguides
DC-10 rudder	Enclosures
L-1011 vertical fin	Commercial products
NASA wet wing	
Helicopter blades	

been used in secondary structural applications for many years, e.g., in aircraft wing-to-fuselage fairings or fillets, and in engine fairings. Radomes, which were formerly constructed mainly from fiberglass, are now being constructed from advanced composites. Significant weight reductions are being realized by replacing existing aluminum or titanium cover sheets with those made of composite materials.

The design concepts, inherent properties, potential benefits, and potential uses of composite materials and structures have been demonstrated through the extensive development efforts conducted and/or

sponsored by the Air Force. Figure 2 outlines the eight, interrelated, principal elements of the Air Force programs* in terms of the development and capabilities attained to date and the requirements for growth and future needs. They are

1. Technical base programs.
2. Flight service experience programs.
3. Production hardware commitments.
4. Substitutional design of composite structures (B-1, F-18).
5. Replacement design of composite structures.
6. Advanced design of composite aircraft studies.
7. Advanced design and development of composite structures and components.
8. Potential full weapon system application.

The Air Force has been active in the development of composite materials and potential applications in recent years and is continuing to support essential current and new programs at an annual rate of approximately \$25 million.⁽¹⁵⁾ The work accomplished to date has firmly established that advanced composite materials can offer several specific advantages leading to reduction in cost: reduction in weight, higher elastic modulus in structures, tailoring to desired load properties, and increased durability, less maintenance, and improved resistance to

* Some detailed information on these programs is provided in Refs. 7-21, and additional information is available at the Structures Division of AFFDL. A comprehensive review and briefing on the *Development of Composites for Air Force Systems* was presented at the Joint NASA/Air Force Symposium on Composites at George Washington University, Washington, D.C., June 11-12, 1975, by Colonel Dale Ward, Commander Air Force Wright Aeronautical Laboratories, AFSC (Ref. 15). A review of Military Department and NASA programs on advanced composites, presented at that symposium, is available in an article by Leonard A. Harris, Office of Aeronautics and Space Technology, NASA, published in the March 1976 issue of *Aeronautics and Astronautics* (Ref. 21).

An Air Force "roadmap" on the development and applications of advanced composites for space and missile systems is being prepared by SAMSO and AFWAL. The *Report of the USAF Scientific Advisory Board Ad Hoc Committee on Advanced Composites Technology*, September 1976, provides a review of current and needed programs; however, the SAB does not address the EM issues discussed in this Rand report.

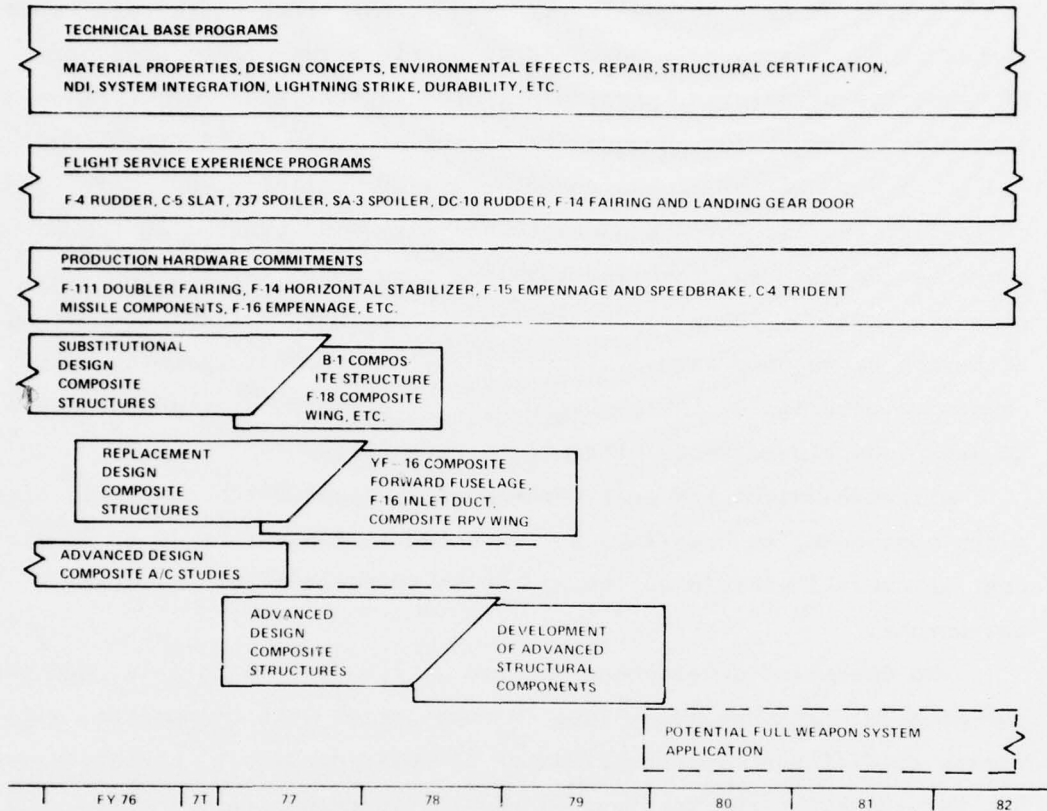

Fig. 2--Air Force development of advanced composite structures (Ref. 15)

fatigue. Full-scale composite structures have been successfully produced and have been demonstrated in production applications.

During the next 5 years, the Air Force hopes to develop the ability to extend the application of composite materials to larger strength-critical structures, such as fighter aircraft wings, and large components of replacement-type design.⁽¹⁵⁾ Composites are expected to be used in engine applications and for RPVs and space vehicles.

The development of lower-cost manufacturing methods will increase volume production. Current estimates indicate that composite structures will begin to show a 15 percent cost savings on an item-by-item comparison with metal counterparts, and an increased use of 10 to 30 percent in total airframe design. Similarly, an expanded use of composites in missile and spacecraft structures is anticipated.

Within the next decade (early 1980s), the state of the art is expected to be sufficiently advanced to permit large-volume production of composite structures, particularly for fighter and trainer class aircraft. Designs for advanced aerospace vehicles built predominantly (40 to 65 percent) of composite materials are anticipated. More specifically, the Air Force expects to see a growing program in the development of large-area wings and fuselage structures for fighter and bomber aircraft. The need for research on warm-to-hot structures and EM hazard protection should stimulate the development of metal-matrix composite materials. There should also be corresponding advancements in new production methods within this time frame.

Although weight and cost savings will depend on the specific structures concerned, such savings are expected to range from 10 to 20 percent in overall vehicle design and up to 40 percent for selected components.

The increased development and use of composite materials, and the use of metals and hybrid designs in combination with composites, will create significant opportunities for advanced designs of aerospace vehicles. However, the substantial changes in mechanical, thermal, and EM properties exhibited by composites will demand an equal increase in the knowledge and understanding of these parameters in order to ensure maximum benefits and compatible EM functional capabilities.

The need for building an interdisciplinary scientific data base and an integrated program to solve EM problems is generally understood and is included as an objective of the Air Force planning activities. Some of the specific problem areas were listed earlier in this section and will be discussed below. However, a reassessment of the basic EM requirements associated with this program⁽¹⁵⁾ would be highly advisable.

FUNDAMENTAL EM PARAMETERS OF ADVANCED COMPOSITES⁽²²⁻²⁷⁾

The proposed objective is to determine the fundamental EM parameters of advanced composite materials by employing measurement techniques and by the design and use of combined computer model and analysis programs.

Critical EM parameters and examples of suggested measurement techniques for use and evaluation are listed below:

1. Fundamental EM parameters.
 - a. Dielectric constants, i.e., electrostatic energy stored per unit volume for the unit potential gradient (permittivity).
 - b. Loss factors, i.e., loss tangents, attenuation, insulation factor (dB/cm versus frequency).
 - c. Resistivity, i.e., conductivity in ohm-cm with volume and variation versus thermal properties.
 - d. Permeability; magnetic induction and magnetizing force.
 - e. Reflectivity and absorption versus frequency--antenna performance.
 - f. Impedance; volume versus frequency.
 - g. Arc resistance.
 - h. E-field and H-field shielding characteristics, i.e., dB attenuation versus energy level versus frequency.
 - i. EM properties versus thermal variations.
 - j. Polarization from reflective surfaces.
 - k. Dielectric strength.
2. Evaluation of measurement and analysis techniques for obtaining fundamental parameters.
3. Evaluation of techniques for measuring and analyzing the vulnerabilities and shielding effectiveness of the following:
 - a. Surface impedance parameters.
 - o Unbroken infinite plane sheet.
 - o Closed seamless hollow body.
 - o Linear seam in infinite sheet.
 - o Simple seams in hollow body.
 - o Coaxial and waveguide plane wave.
 - o Concentric coaxial and triaxial structures.
 - b. Coupling between loops and probes.
 - o Infinite plane shield.
 - o Enclosed detector (loop and probe).
 - c. Plane wave transmission, reflection.
 - o Waveguide transmission and reflection.
 - o Circular coaxial.
 - o TEM cell (controlled E-field orientation).

- o Far-field anechoic chamber.
- d. High-voltage-discharging phenomena.
 - o Atmosphere.
 - o Magnetospheric substorm charging in space environment.
- e. Direct current injection.
 - o Current levels versus damage effects.
 - o Voltage levels versus damage effects.
- f. Dielectric sample holder--resonant circuit.

ENERGY SOURCES AND ENVIRONMENTS CONTRIBUTING TO EM HAZARDS⁽²²⁻⁴⁷⁾

The proposed objective is (1) to identify, define, and describe the energy sources and environments contributing to EM hazards associated with composite materials and to determine the threat definition that is a basic requisite for research and analysis of protective measures, and (2) to evaluate the effect of these energy sources on the electrical, thermophysical, and mechanical properties of composite materials and structures.* Examples of areas of investigation are as follows:

- 1. EM energy sources.
 - a. Gamma rays.

* In addition to the current RADC/RBCT program, AFFDL/FES and AFML at Wright-Patterson Air Force Base are designing several new programs for the assessment of the vulnerability/survivability of advanced composites that should address some of the items listed. (See Refs. 37, 39-44.)

Where feasible, energy sources on space environments should include gamma rays, X-rays, near and far ultraviolet, high and low charged particles (electrons and protons), magnetospheric charging, and temperature. Effects of changes in thermophysical, mechanical, and fundamental EM parameters (see page 15) versus time on advanced composite materials should be measured.

Simultaneous exposure of composite materials, long-term simulation at reasonable rates (less than 10x) and in situ (in vacuo) measurements are suggested. A compromise may be necessary where environmental exposures are made in series and subsequent evaluations are made ex situ (outside vacuo). These compromises can have an impact on the validity of the data. Contamination-free environment test chambers should be used so that test results are true assessments of the degradation process. SAMSO, under Contract No. F04701-74-C-0562, "Properties of Metalized Flexible Materials in the Space Environment," is developing some of the essential components approaching the desired test capabilities.

- b. X-rays.
 - c. Far ultraviolet exposure (earth and space environment), 1100 Å to 1600 Å.
 - d. Near ultraviolet exposure (earth and space environment), 1600 Å to 4000 Å.
 - e. IR.
 - f. Lasers.
 - g. EMI.
 - o Radar pulses.
 - o CW man-made radiations.
 - o Internal, spurious, RF, AC, rusty bolt effects, erosions.
 - o Antenna radiations.
 - o Millimeter waves (space operations).
 - h. EMP (forthcoming criteria from AFWL).
 - i. Lightning.
 - o Induced voltage from lightning strikes, direct attacks.
 - o Swept stroke.
 - o Radiated emissions.
 - o Fields generated by close lightning.
 - j. Static electricity (triboelectric charging).
 - o Corona discharges.
 - o Streamerings.
 - o Sparking.
 - o Electric fields caused by the use of metal and composites.
 - o Bonding of dissimilar materials.
 - k. Proton exposure (space environment).
 - l. Electron exposure (space environment).
 - m. Magnetospheric substorm charging.
2. Properties for evaluation of effects on EM energy sources.
- a. Electrical (items listed on pages 15 through 17).
 - b. Thermophysical (evaluate only those properties affected).
 - o Reflectance.
 - o Emittance.
 - o Conductance.
 - o Absorptance.

- o Thermal expansion.
- c. Mechanical (evaluate only those properties affected).
 - o Young's modulus.
 - o Yield stress.
 - o Yield elongation.
 - o Ultimate failure.
 - o Fatigue behavior.
 - o Fracture strength.
 - o Stress rupture due to high temperature.
 - o Creep due to high temperature.

Lightning Hazards

One example of a serious hazard to composite materials is the lightning environment. Figure 3,⁽⁴⁶⁾ which is a diagrammatic representation of a lightning model, shows how lightning is a serious hazard to

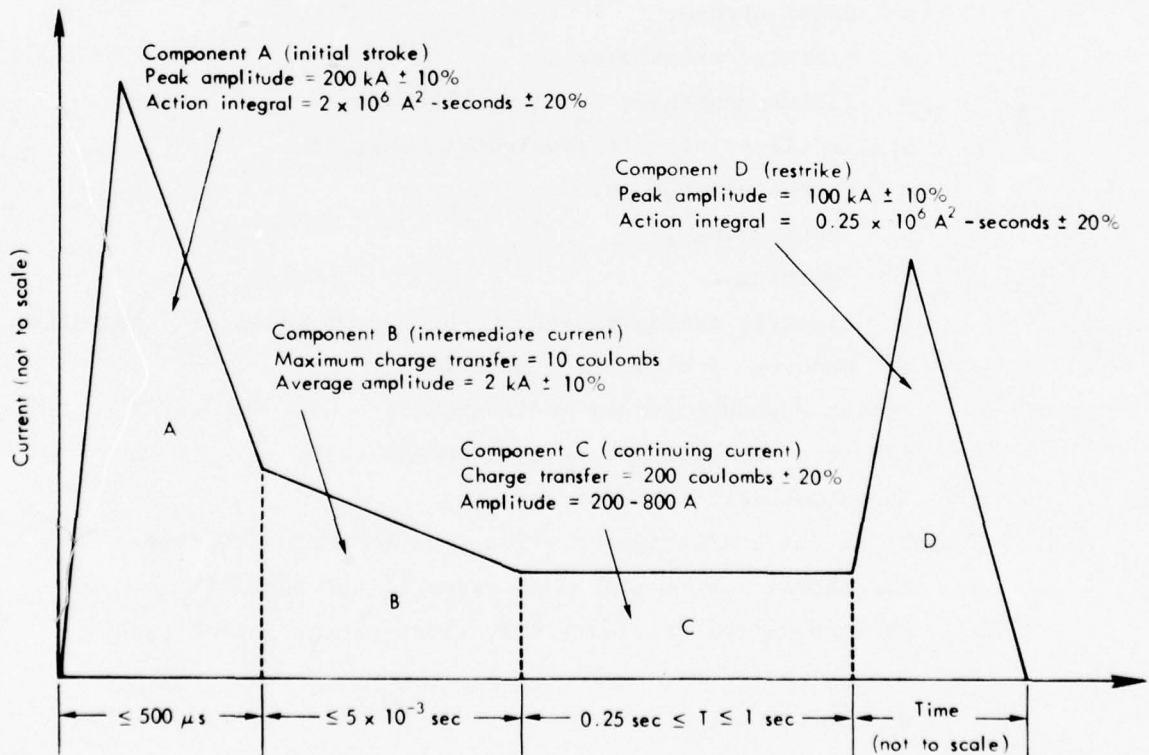

Fig. 3--Diagrammatic representation of a lightning model

metal structures, and especially to nonconductive composites, due to the high current levels and high EM fields that can be generated. As mentioned earlier, the matrix in nonmetallic composite materials is a dielectric and any current must flow through its fibers. In composite materials consisting of graphite fibers, the fibers are only 7 to 10 μ in diameter and the resistivity is high enough to cause heating, which results in structural damage and arcing at high current levels.

Lightning can originate from storms or from human modification of the natural atmospheric environment. The characteristics of lightning vary and are different for cloud-to-ground and intracloud discharges.* Storm-produced intense cloud-to-ground flashes may consist of 3 to 10 large current surges that reach peak currents of 200,000 A at a rise-time rate of 100,000 A/ μ sec and a total charge transfer of 200 coulombs. In typical flashes, the corresponding values are 20,000 A at a rise-time rate of 20,000 A/ μ sec and a charge transfer of 20 coulombs. The intracloud flashes, which account for about two-thirds of all flashes, usually consist of a larger number of current surges (about 30 per flash). The peak currents are usually less than 10,000 A at a rise-time rate of 10,000 A/ μ sec. The total charge transfer is typically 20 coulombs. Triggered lightning generally results from the introduction of a long electrical conductor (100 m) into a thunderstorm environment in which the electric field is approximately 10 kV/m. The conductor can be shorter to trigger lightning in higher electric fields, e.g., 10-m conductors have been hit in 80 kV/m fields. When the potential difference between the tip of the conductor and the ambient atmosphere becomes about 1 million V, triggered lightning can occur.

Damage from lightning--and the measures to protect against it--are well known and well documented. Electrical power controls, wiring systems, C&E equipment, and EM instruments installed in aerospace vehicles and ground facilities are susceptible to transient voltages induced by

* For additional data, see Refs. 28, 29, and 46. See also N. Cianos and E. T. Pierce, "Models for an Intracloud Lightning Flash," Technical Memorandum, Stanford Research Institute, Menlo Park, California, November 1972; and N. C. Cianos and E. T. Pierce, *A Ground Lightning Environment for Engineering Usage*, Technical Report 1, Stanford Research Institute, Menlo Park, California, August 1972.

lightning strikes. The electric energy radiated and the magnetic fields generated by nearby lightning flashes that are not direct strikes produce significant hazards to modern electronic systems, such as the new systems and fly-by-wire systems that function at low signal levels and use digital circuitry and solid-state components with wide-band and fast time-response characteristics. In addition, metals are being widely replaced by new composite materials that have significantly less effective shielding properties, so they are more vulnerable to direct and radiated lightning threats.

In conventional metal aircraft, lightning protection is mostly provided against what may be called the "direct effects" of lightning, including burning, blasting, and the physical deformation of vehicle skins and structural elements. In current aircraft, some extra protection is provided for small nonmetallic sections such as radomes, canopies, antenna apertures, etc. With the development of aircraft composed of 60 to 80 percent composite materials,⁽¹⁷⁾ vulnerability to lightning hazards will increase substantially. Existing lightning protection specifications, such as MIL-STD-5087B, concentrate on electrical bonding and on minimizing the effects of lightning. Other criteria, such as those in FAA Advisory Circular No. AC 20-53, provide guidance for protection against lightning ignition of flammable fuel/air mixtures.

The radiation fields due to lightning vary with time and frequency, and with distance from the discharge; generally, the variations in time and frequency are correlated with the different stages of the lightning flash. The radiation from lightning consists of many pulses; a single lightning flash can generate approximately 10^4 identifiable pulses for frequencies from quasi-dc to 10 GHz. The radiated fields corresponding to 3 V/m at distances of 100 km can be of sufficient amplitude to cause interference and affect the performance of C&E equipment, depending on sensitivity and shielding characteristics. Calculation of the fields due to close lightning generally involves near-field theory at the lower frequencies and far-field theory at the higher frequencies.

Further efforts are needed in the measurement and analysis of radiated emissions and fields generated by close lightning, namely:

- o Theoretical and model studies based on existing experimental data in the frequency range of 1 to 300 MHz, which would incorporate the details of pulse structures.
- o Experimental measurements aimed at defining pulse structure numbers, time separation distributions, amplitude distributions, and the association between pulses at differing frequencies. Such measurements should be made at a single frequency and, if possible, at several frequencies or frequency ranges simultaneously.
- o Experimental measurements (taken inside aircraft having metal, composite, and hybrid fuselages) of signals generated by close lightning.* The minimum attention given to such measurements and the lack of programs, both past and present, are serious omissions in the Air Force program of preventive design for lightning protection. Tests can be conducted at minimum cost and risk. The equipment required would be relatively simple. Antennas could be mounted both inside and outside the aircraft to measure the penetration of lightning signals. Such measurements could be made at a safe distance (10 km) from very active storms.
- o Tests to measure the attenuation characteristics of composite materials versus energy radiated from lightning are also needed. These tests would be more costly and might require specially constructed RPVs and special radio relay instrumentation because of the possibility of the test vehicle's being destroyed by direct lightning strikes. Costs might be lower and tests safer if a glider or cylinder constructed of composite materials could be towed behind an aircraft of known strike-prevention construction. Similar tests to compare the attenuation data, from radiated lightning energy, for fuselages of metal with those of composite materials can be conducted in the laboratory by using simulated lightning. However, such

* J. E. Nanevicz, R. C. Adams, and R. T. Bly, *Airborne Measurement of Electromagnetic Environment Near Thunderstorm Cells (TRIP-76)*, Final Report, Stanford Research Institute Project 5536, Contract No. NAS-9-15701, March 1977. (These tests provided highly useful data and evidence for needed additional measurements.)

tests cannot cover the effects of total lightning and are therefore limited. Certain features, such as continuing currents, a high rate in the rise of currents, and the fine structures of surges as a function of frequency, all occurring simultaneously, cannot be adequately simulated.

Static Electricity Hazards

Static electricity or triboelectric charging occurs when an aircraft or missile encounters precipitation and cloudy conditions and when the potential of the vehicle or parts of the vehicle reach a level where electrical breakdown of the air occurs. (Triboelectric charging occurs when two dissimilar materials come into contact and then separate.) Electricity usually discharges from points of high dc fields on the aerospace vehicle. The electrical breakdowns take the form of corona discharges from these extremities, or as streamer discharges across dielectric material surfaces.

These corona discharges generate electrical noise that causes interference when coupled into receiving systems, avionics, and C&E equipment. The magnitude and spectral distribution of this interference depends on several factors, e.g., the strength and spectral characteristics of the source discharges, the manner in which the disturbances produced by the discharges couple into the antennas and other extraneous parts to C&E equipment, and the discharge current and its distribution among the discharging extremities. At operating altitudes of aircraft, these discharges are short bursts of current; they generate noise over a wide band of frequencies. The sources of noise can be classified as follows:

1. *Corona discharges*--occurring at the antenna and other extremities of the airplane when the airplane is raised to a high potential by triboelectric charging, which is caused by precipitation particles (e.g., ice crystals) striking the aircraft.
2. *Streamer discharges*--generated by streamers or sparks that cross dielectric surfaces to relieve the triboelectric charge,

which is caused by impinging precipitation particles on the aircraft surface.

3. *Sparking*--produced by individual impinging precipitation particles, which create overlapping step-fronted pulses, as they acquire charge upon impact in a region of reciprocal antenna fields. The current levels can range from a low of 25 μ A charging current over a 50-ft² charging surface to 3 mA, and the potential of an aircraft can be raised to 300,000 to 400,000 V above electrical ground level. The frequency spectrum varies from a few hertz to 10⁹ Hz, and the sparking energy is very pronounced in the 30 to 3000 MHz range.

These noise sources can adversely affect such C&E equipment as digital avionics, airborne radio communications, navigation receivers, glideslope receivers, automated digital control equipment, and electromagnetic devices.

The use of nonmetal surfaces adjacent to exposed metal surfaces, including flush-mounted antenna structures, in high-performance aircraft and aerospace vehicles operating in or through the atmosphere may increase the hazards to static electricity.

Studies of frictional electrification⁽²⁹⁾ resulting from the impact of particles at supersonic speeds show that the intensity of the generated interference is proportional to the magnitude of the current discharged. The interference level is dependent on coupling between the affected circuits and the location of the discharge noise source. The locations of the discharge noise source, which occur at points on the aircraft where the electric field is sufficiently high, are determined by the geometry of the aircraft and the aircraft potential. The potential is a function of charging current. A knowledge of the vehicle's charging processes and the magnitudes of the resulting charging currents is essential in order to determine the magnitude of the interference that will be encountered.

Specifically, research and measurement programs are needed for the development of a technical data base that can be used in the design of mathematical models for corona-discharge noise sources, sparking, sur-

face streamer-discharge noise sources, electromagnetic coupling between sensors, and the determination of equivalent noise fields.

The current supporting test data and existing measurements are outdated, and are generally applicable to the shapes and the operating characteristics resembling those of transport aircraft.^(28,29) The source of existing data on static charging levels and phenomena is severely limited in vehicle type, speed, and operating altitudes, and the data are being used only because new test programs have not been initiated. Hence, the following further work is suggested:⁽³⁷⁾

1. The charging mechanism and energy levels in advanced composites and composite-and-metal hybrid joints and structures should be determined.
2. The coupling data base should be expanded to describe other shapes for use in predicting and analyzing the static electrical charging of missiles, of space vehicles during launch, of rockets, helicopters, RPVs, and conventional metal aircraft, and of new aircraft with advanced composite structures.
3. The data should be collected at various altitudes (near sea level to 50,000 ft) and at speeds up to Mach 2 to 2.5 under various weather conditions. Higher sensitivities and larger dynamic ranges in the instrumentation and measurement equipments will be required.
4. Laboratory testing capabilities should be developed to investigate the local charging rates of different advanced composite materials, structural composition, and other materials of interest versus simulated weather conditions, i.e., ice crystal impact, typical cloud droplets, snow, etc.
5. Noise should be characterized in terms of both frequency--especially above 10 MHz--and energy levels resulting from charging of advanced composite materials and structures. Updating of existing data on metals and plastic insulators is needed. New instrumentation will be required.
6. The use of "method of moments" for expanding the coupling data analysis should be explored.

7. There is a need to develop supplemental analysis models that are responsive to the increased sensitivities of (a) receivers or EM devices introduced by the use of new C&E equipments (digital computers and avionics) and (b) space EM control devices for use in vehicles operating in both the earth's atmosphere and in space environments.

EM VULNERABILITIES AND SHIELDING EFFECTIVENESS CRITERIA (22-48)

The proposed objectives are to define EM vulnerabilities and shielding effectiveness criteria and to determine their impact on aerospace vehicles, systems, and related specifications. A few examples of possible areas of investigation are as follows:

1. EM implications in the use of composites in aerospace vehicles and structures.
 - a. Ground return for electrical power and circuits.
 - b. Electrical bonding of composites with metals.
 - c. Ground planes for antennas versus frequency.
 - d. EM shielding of composite enclosures and C&E equipments (i.e., digital avionics, fly-by-wire, sensitive detectors, switches, etc.).
 - e. Electrical conductivity integrating outer surfaces and fuselages of aerospace vehicles.
 - f. Electro-explosive systems and devices.
 - g. Weapon carriers and aircraft missiles and stores; EM controls, nuclear and nonnuclear.
 - h. Fuels stored in composite tanks; vulnerability to electrification and charging detonation hazards.
 - i. Crew safety.
2. Thermal properties: * resistivity, conductivity, and expansion versus temperature, moisture, and stress.
3. Changes in EM thermophysical and mechanical properties versus

* The thermal conductivity properties of metals are used to dissipate heat generated by EM equipments.

moisture,⁽⁴⁸⁾ chemicals, stress, atmosphere, and space environments.

4. Current attenuation specifications* based on metallic enclosures and structures.
 - a. EM devices.
 - b. EM equipments and systems.
 - c. EM coupling (shielding cables, etc.).
5. Identification of major weapon systems, EM systems, and aerospace vehicles that may be affected.
6. Documentation of available EM shielding materials and uses, and recommendations for solutions to problems identified in the programs listed in the previous subsection.

Figure 4(a) illustrates the H-field shielding effectiveness of several representative materials, based on measurements conducted by F. A. Fisher⁽²⁶⁾ of General Electric. As shown, the H-field attenuation properties of 0.1-in. thick composite material (boron-epoxy laminate) may be substantially lower (50 to 60 dB) than those of 1/8-in. thick aluminum at the frequencies shown. Figure 4(b) indicates that, due to higher conductivity properties, graphite-epoxy composites may provide more effective shielding, at the frequencies shown, than boron-epoxy and will increase as the number of plies and the thickness are increased. However, the addition of thin aluminum foil or mesh bronze screening will substantially increase the shielding properties, as shown in Fig. 4(a).

Figure 5 illustrates the use of coupled loops and shielding enclosure test setups for measuring shielding effectiveness. It should be noted that the data are dependent on the coil spacing in the test because the coil spacing affects the impedance of the magnetic field, and the shielding is determined, in part, by the impedance mismatch

* Current specifications permit waivers of 20 dB or more to shielding requirements between internal avionics and external EM ambient and incident fields where enclosures and vehicles are constructed of metal materials. With the use of composites, the differential in shielding properties will need to be determined and added as required.

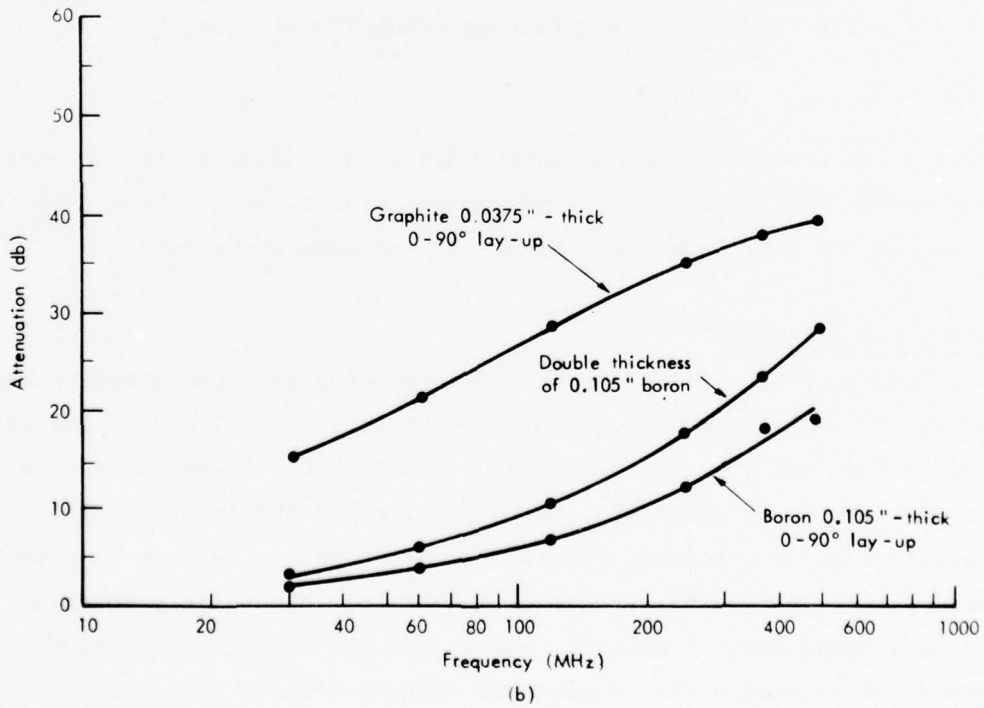
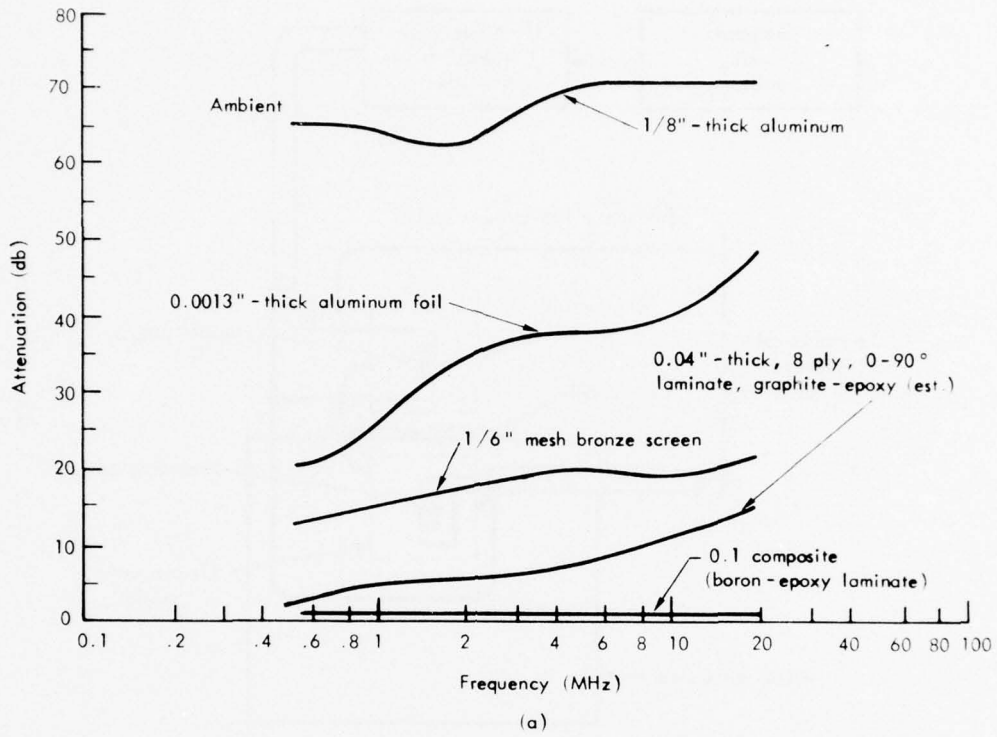

Fig. 4--H-field shielding effectiveness of representative materials

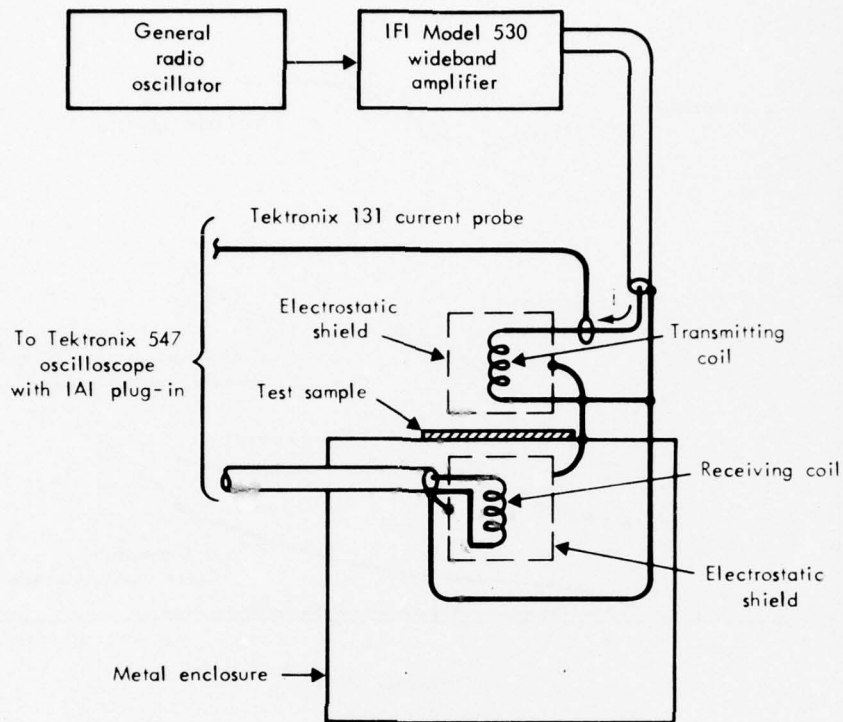

Fig. 5--Setup for shielding effectiveness tests

between the field and the shielding materials. Although the attenuation of the composite material measured increases as the frequency is increased, it remains below that of the representative metals.

PROTECTIVE MEASURES (22-47)

The substantial efforts of those attending past workshops on the EM hazards associated with composite structures, coupled with the extensive work on the Advanced Development Plans (ADPs) organized and conducted by AFFDL and RADC/RBCT, have resulted in the identification and listing of major critical areas where work needs to be done to resolve the problems created by the use of nonmetallic composite materials.

A program dealing with EM hazards and the impact of advanced composites will require the coordinated work of experts in a number of technical areas. Engineers and scientists are needed who are

knowledgeable about advanced composite materials, mechanical properties, EM properties, thermal conductivity, shielding effectiveness, testing technology, definition of EM energy sources (including space environments), vulnerability assessment, and analytic processes. It is strongly recommended that a central management activity be established within the Air Force to coordinate these research efforts.

It is also suggested that a team be organized within the Air Force to conduct continuing surveys and to compile and disseminate data on existing programs and on new developments in order to establish an information base to support the work required for the design and development of protective measures.

Although such surveys should precede initiation of new efforts, some of the currently funded programs should be continued and the more critical programs should be initiated. To help determine which programs are critical, perhaps it would be useful to group the items to be investigated into programs bounded by well-defined objectives. Four programs are suggested to illustrate this approach:

1. A program to develop a measurement and instrumentation technology, as well as computer-aided analysis codes, for determining the intrinsic EM parameters of advanced composite materials and structures and the combinations of composite-and-metal hybrid structures.
2. A program on "Engineering Solutions for Protective Measures." This program would endeavor to solve the more immediate, specific problems associated with EM hazards in current/new production vehicles, structures, systems, and components.
3. A program on "Testing Technology." This program would focus on the principal energy sources of EM hazards, i.e., lightning, static electricity, EMP, EM effects on thermal conductivity, moisture, rain, chemicals, etc. (A close working relationship should be established with other programs having similar capabilities relating to space environments.)
4. A program to develop "Analytical Capabilities." This program would be directed toward the design of long-term vulnerability

assessments and solutions leading to broad applications and scientific understanding of basic EM phenomenology. It would also provide tailored design specifications that would supplant engineering fixes and retrofit solutions. This capability should be added to the existing EMC codes of the Air Force Intrasystem Analysis Program (IAP).

A series of computer programs, models, and codes⁽³⁵⁾ developed in recent years has been used extensively to analyze and predict the effects of the EMP, nuclear weapons, and EMC on circuits and EM systems in aerospace vehicles.⁽³⁷⁾ These programs generally include coupling modes, where the principal entry points of extraneous EM energy and coupling to internal components, cables, etc., are through apertures and antennas, since metal structures and aluminum materials provide (in excess of 20 dB) shielding and attenuation properties in other sections of the vehicle. When substantial portions of vehicles are made of composite materials, the entry points are no longer confined to apertures and antennas, unless the EM shielding properties and specifications associated with metal materials and structures are reestablished by adding appropriately conductive substances to the composites.

In the Air Force EMC Intrasystem Analysis Program,^{*(37)} composites will also substantially affect the computation of coupling through apertures and/or direct radiation from component to component, box to box, box to wire, field to wire, antenna to antenna, and to internal wires, when enclosures or portions of the aerospace vehicle are constructed

*The Air Force EMC Intrasystem Analysis Program (IAP) will provide capabilities for computing fundamental levels of EMC and shielding requirements. The IAP is recommended for use in determining the EM impact of substituting composites for metal enclosures and structures.

The IAP models, computer codes and tapes, and instruction manuals, as well as information on the development of supplemental models and analysis capabilities to determine the EM impact of composites, are available at Rome Air Development Center (RBCT), Griffiss Air Force Base, New York 13441.

A brief overview of the IAP is given in the Appendix.

of low-conductive composites. Moreover, as stated earlier, current specifications pertaining to EM shielding effectiveness are based on metal enclosures. Thus, with the use of advanced nonmetallic composites for enclosures and for substantial portions of vehicle body skins and structures, the computer codes will need to be modified. In addition, as the means for deriving the EM properties of advanced composites are established, these properties should be integrated into the computer programs.

A principal objective of the present study is to develop a capability for designing and manufacturing advanced composites having specified EM properties. These properties will depend on how the composites are used and could be derived by the four programs mentioned above, as part of the design of tailored specifications for EM shielding, EMP, and EMC control in aerospace EM systems.

IV. THE MEASUREMENT AND ANALYSIS DATA BASE: A SUGGESTED FORMAT

In order to develop some standard measurement procedures for obtaining and cataloging the information required for a data base, it is desirable to design a format, such as the one suggested in Table 3, to simplify the task. The format should be flexible to allow for alterations in the measurement and analysis procedures as they progress.

The required data can be derived by using existing measurements, or by devising new and additional measurements, or by analysis techniques; documentation of the methods used is essential. The information can be given in simple narrative form, in tabular listings, plotted curves, engineering notes, and/or standard technical reports--whichever seems appropriate and most expedient. However, the data should be listed if possible (or referenced) according to the area of investigation to which it applies, as shown in Table 3.

The measurement and analysis techniques employed in obtaining the data may be selected from those listed on pages 15 and 16 of this report, and/or from those described in the Rome Air Development Center report, *A Technology Plan of Advanced Composites*.^{*(44)} If other techniques are employed, a brief description and/or drawing should be included with the data, along with an explanation justifying the use of a particular technique.

The advanced composite material sample used in the measurement or analysis can be described in narrative form, but simple sketches giving critical dimensions and composition are preferable, since they simplify the task of compiling the information.

* Some suggested measurement techniques for use in obtaining intrinsic EM parameters below 50 MHz include: (a) for conductivity, measure the resistance, using the two- and four-point probe method; (b) for permittivity and dielectric strength, measure the capacitance between two electrodes; (c) for permeability measure the magnetic force in the air gap of magnetic field poles; and (d) above 50 MHz, use reflectance or transmission measurement techniques.

Suggested techniques for obtaining shielding effectiveness, defined as the ratio of the incident to the transmitted fields expressed in decibels, include the two-loop method. Various methods need to be related to an accepted basic definition. A proposed basic definition for shielding effectiveness is the ratio of the field strength of a plane wave incident perpendicular to a plane infinite sheet to the field transmitted, expressed in decibels.

Table 3

SUGGESTED FORMAT FOR THE MEASUREMENT AND ANALYSIS DATA BASE

Area of Investigation	Data Requirements
Advanced composite materials, structural composition, and fabrication	Give established labels and list the composition of the matrix and reinforcements. New and/or additional materials, if used, should be described. Include data on any chemical or physical treatment applied that may affect the EM properties. (See Table 1 for a listing of the most common composite sites currently being used.) Describe the structural composition and geometric-physical volume of the fibers (reinforcements); the matrix, fabrication/composition, and lay-ups of the finished products. (See pages 5 through 7 for a list of the essential data.)
Current and potential use of advanced composite materials and structures	Provide simple sketches and/or dimensional drawings of the sample or specimen and its structural use. Document the size limitations of the samples used. (See pages 10 and 11 for a list of essential data.)
Fundamental EM parameters of advanced composites	Test data can be documented in tabular form, plotted curves, and supporting test results and notes. (See pages 14-16, and Ref. 44, for a list of critical parameters and suggested measurement techniques.) Describe the measurement instrumentation employed in obtaining the data requested. Provide drawings or sketches of instrumentation and test procedures. The objective is to derive convenient and reliable measurement methods leading to standard procedures and valid data. (See Fig. 5 and the listing on pages 15 and 16; see also Ref. 44.)
Energy sources contributing to EM hazards	Describe the type of energy source, energy levels, voltage and current, and frequency as relevant. (See pages 16 through 18 for a list of energy sources and properties.)
EM vulnerabilities and shielding effectiveness criteria	Describe the functional/operational problems related to the tests and measurements, and identify the specific areas affected. Include deviations resulting from variations in temperature, moisture, and stress. (See pages 25 and 26 for examples of areas of investigation.)
Protective measures	Describe the protective measures employed relative to specific hazards and vulnerabilities. (See page 28 and Ref. 44.)

V. SOME CONCLUDING SUGGESTIONS

Based on findings to date, and supported by interim data emerging from the assessment exercise, some concluding suggestions seem in order.

1. The overall advantages in cost and weight savings to be gained with the use of composites must include the total system costs, as well as the requirements listed in this report. Thus, an assessment of the basic EM, thermal, and environmental requirements associated with current and proposed programs, where composite materials are being used or proposed for use, would be highly advisable.
2. A similar assessment should be made of repair and maintenance practices involving the use of composite materials, enclosures, and structures.
3. Applications of composites should be preceded by the design and analysis of, and provisions for, protective measures, such as those suggested in this report and under development in current Air Force projects.
4. Capabilities for measuring and analyzing the intrinsic EM, thermal, chemical, etc., properties of composite materials, for testing the impact of atmospheric and space environments on these properties, and for determining their effects on mechanical properties should be established within the government agencies and industry concerned with the manufacture and use of composites.
5. Capabilities should be developed for designing and manufacturing composite materials with specified EM properties tailored to the requirements imposed by overall system applications and operating environments.
6. Existing EMP codes, and the Air Force EMC Intrasystem Analysis Program (IAP), should be modified to be responsive to the substantial variation in the EM properties of composites and to provide capabilities for analyzing the hazards of operational environments.

Appendix

AN OVERVIEW OF THE AIR FORCE INTRASYSTEM ANALYSIS PROGRAM (IAP)

The Air Force Intrasystem Analysis Program (IAP) is based on extended Air Force and Rand Corporation research on technical processes to achieve electromagnetic compatibility (ECM). The principal components of the IAP include:

1. The Intrasystem Electromagnetic Compatibility Analysis Program (IEMCAP). This program will provide the IAP with a computer capability for assessing EM vulnerability, designing specification limits, analyzing EM compatibility and waivers, and controlling undesired EM energy in communications/electronic systems. It includes:
 - a. EM generator models.
 - b. Transfer coupling models; examples are
 - (1) Filter models
 - (2) Free space propagation model
 - (3) Antenna gain model
 - (4) Intravehicular propagation model (antenna-to-antenna)
 - (5) Ground propagation model (antenna-to-antenna)
 - (6) Wire-to-wire coupling model
 - (7) Field-to-wire coupling model
 - (8) Case-to-case coupling model
 - c. EM receptor models.
2. A series of supplemental analysis models for use in conjunction with the IEMCAP. These models will provide additional analyses for aircraft stores, electroexplosive devices and subsystems, lightning, magnetospheric substorms, and static electricity.
3. Nonlinear and EM/near-field analysis models. These models will characterize the input/output relation of nonlinear circuits, EM-field interactions, and antenna and aperture coupling, all of which are being developed for off-line use.

4. Instrumentation, test, and measurement support equipment.
5. Validation.
6. Implementation.
7. Training programs.
8. Air Force management (data base).

The performance of EM devices, components, subsystems, and systems depends on electromagnetic compatibility--i.e., on the ability of these systems to function without unacceptable degradation due to EM interference. Electromagnetic compatibility can only be achieved through good engineering design and control practices. Assessments of the vulnerability of devices to internal and external extraneous EM energy sources require extensive testing procedures.

Substantial increases in electromagnetic equipments for weapon systems, and the vulnerability of these equipments to extraneous EM energy sources, have created a need for new and advanced design and engineering practices to achieve electromagnetic compatibility.

Traditional EMC control programs integral to EM equipments and systems acquisition rely on the application of EMC limits described in a series of Military Standards and Specifications. These limits are intended to provide a measure of control over equipment emission and susceptibility characteristics so as to minimize potential interference degradation. Unfortunately, they are *general* limits that are applied to all equipments and therefore may not ensure electromagnetic compatibility for a specific system. The magnitude of energy in the interference coupling paths, dynamic ranges of EM-generating energy sources, and sensitivity of receptors change significantly within systems, as well as from system to system.

The new Intrasystem Analysis Program, based primarily on Rand reports R-1114/1-PR, *An Electromagnetic Compatibility Analysis Program for the 1970s (Selected Issues)*, and R-1690/1-PR, *An Intrasystem Analysis Program (IAP): Appendix to R-1114/1-PR*, has been developed by the Air Force for the use of defense contractors concerned with ground and aerospace systems acquisition. The program will provide a computer capability for predicting the effectiveness of EMC controls prior to construction and thus prevent possible costly modifications.

The Office of Primary Responsibility for the IAP is Headquarters, Air Force Systems Command (SDDE). Rome Air Development Center (RBC) is the lead agency for the development of the Intrasystem EMC Analysis Program (IEMCAP), as well as for the development of the supplemental model of aircraft stores, the integration of all supplemental models, and nonlinear/EM fields analyses. The Air Force project offices responsible for development of all supplemental models are listed in Table A.1. An Air Force EM Working Group, chaired by AFSC (SDDE), with representatives of the principal Air Force agencies as members, was established early in the program to prepare the requirements and plans for its use.

The IAP is offered to industry for its use during contractual procedures involving systems acquisition, during the conceptual phases, and during the development and actual acquisition phases. It is applicable to ground, aeronautical, missile, and space system acquisition. In addition, the program will offer a new approach in management control, since it will provide the Air Force and industry with a continuing visibility of preferred EMC applications and costs.

The IAP will have a substantial impact on weapon systems acquisition and will demand changes in contracting procedures because it will afford a means of measuring contractor performance based on adherence to general specifications and on adherence to specific specification limits.

Table A.1
AIR FORCE INTRASYSTEM ANALYSIS PROGRAM (IAP)

IAP Components	Contracting Organization	Air Force Responsible Project Office
1. Intrasystem EMC Analysis Program (IEMCAP)	McDonnell Air Company	RADC/RBC
2. Supplemental analysis models Aircraft stores Electroexplosive devices Electroexplosive subsystems Lightning Magnetospheric substorms Static electricity	RADC (in-house project) Los Alamos Scientific Lab Sandia Corporation General Electric Company AFGL/PWW (in-house project) Stanford Research Institute	RADC/RBC ASD/ENA ASD/ENA FDL/FGL & NASA/LRC SAMSO/AWST ASD/ENA & RADC/RBC
3. Nonlinear and EM/near-field analysis models (for off-line use) Nonlinear circuit analysis EM fields analysis Advanced composites	Signatron, Inc. RADC; Syracuse University; and BDM Corporation University of Notre Dame; Rochester Institute of Technology; University of South Florida (In-house project)	RADC/RBC RADC/RBC RADC/RBC
4. Instrumentation, test, and measurement support equipment	McDonnell Aircraft Company	ASD/ENA, RADC/RBC
5. Validation	Sachs/Freeman Associates, Inc.	RADC/RBC
6. Implementation	Syracuse University	RADC/RBC
7. Training programs	(In-house project) AF Product Divisions	AFSC/SDDE, RADC/RBC
8. Air Force management (data base)		RADC/RBC

REFERENCES

1. *Proceedings of the Conference on Fibrous Composites in Flight Vehicle Design*, AFFDL-TR-72-130, Air Force Flight Dynamics Laboratory, Ohio, September 1972; and *Proceedings of the Second Conference on Fibrous Composites in Flight Vehicle Design*, AFFDL-TR-74-103, Air Force Flight Dynamics Laboratory, Ohio, September 1974.
2. Kaminski, B. E., G. H. Lemon, and E. L. McKague, *Development of Engineering Data for Advanced Composite Materials: Vol. I, Static and Thermophysical Properties*, AFML-TR-70-108, Vol. I, Convair Aerospace Division of General Dynamics, for Air Force Materials Laboratory, AFSC, Wright-Patterson Air Force Base, Ohio, October 1972.
3. ---, *Journal of Composite Materials*, Techomic Publishing Company, Inc., Westport, Connecticut, Vol. 7, October 1973.
4. Starrett, H. S., et al., *Higher Strain Graphites*, AFML-TR-73-186, Southern Research Institute, for Air Force Materials Laboratory, AFSC, Wright-Patterson Air Force Base, Ohio, October 1973.
5. Kendall, E. G., *Preparation and Properties of Graphite-Reinforced Copper, Lead, and Zinc Metal-Matrix Composite*, The Aerospace Corporation, Los Angeles, California, March 1975.
6. Amateau, M. F., W. C. Harrigan, Jr., and E. G. Kendall, *Mechanical Properties of Aluminum Alloy-Graphite Fiber Composites*, SAMSO-TR-75-55, The Aerospace Corporation, for Space and Missile Systems Organization, AFSC, Los Angeles, California, February 21, 1975.
7. Hertz, J., et al., *Advanced Composite Applications for Spacecraft and Missiles: Phase I, Final Report, Vol. II*, AFML-TR-71-188, Convair Aerospace Division of General Dynamics, for Air Force Materials Laboratory, AFSC, Wright-Patterson Air Force Base, Ohio, March 1972.
8. ---, *Advanced Composites Design Guide*, Los Angeles Aircraft Division of Rockwell International Corporation, under Contract F33616-71-C-1362, for Air Force Materials Laboratory, AFSC, Wright-Patterson Air Force Base, Ohio, 3d ed., January 1973 (being revised under Contract F33615-74-C-5075).
9. Glenn, T. O., and L. C. Koch, *Structural Composites on Future Fighter Aircraft*, MCAIR-73-014, McDonnell Aircraft Company, St. Louis, Missouri, August 1973.

10. ---, *Advanced Composite Technology Fuselage Program*, Convair Aerospace Division of General Dynamics, under Contract F33615-69-C-1494, for Air Force Materials Laboratory, AFSC, Wright-Patterson Air Force Base, Ohio, November 1, 1973.
11. Hudson, J. L., et al., *Advanced Composite Technology Fuselage Program, Vol. VII, Systems Interface Study*, AFML-IR-71-41, Vol. VII, Convair Aerospace Division of General Dynamics, for Air Force Materials Laboratory, AFSC, Wright-Patterson Air Force Base, Ohio, April 1974.
12. Pynchon, George, et al., *Advanced Composites, Missile and Space Design*, AFML-TR-74-97, General Dynamics, for Air Force Materials Laboratory, AFSC, Wright-Patterson Air Force Base, Ohio, June 1974.
13. ---, *Development and Flight Service Evaluation of an Advanced Composite Vertical Fin for the L-1011 Aircraft*, Lockheed-California Company, work in progress under Contract NAS-1-14000 for NASA/LRC, July 1975.
14. ---, *Wing Inlet Composite Advanced Development (WICAD)*, General Dynamics, work in progress under Contract F33615-75-C-5161, for Air Force Flight Dynamics Laboratory, AFSC, Wright-Patterson Air Force Base, Ohio, May 1975.
15. Ward, Dale, *Development of Advanced Composites for Air Force Systems, A Briefing*, presented to the Joint Symposium on Composites, George Washington University, Washington, D.C., June 11-12, 1975.
16. ---, *Flight/Service Programs for Advanced Composite Rudders on Transport Aircraft*, McDonnell Douglas Corporation, work in progress under Contract NAS-1-12954 for NASA/LRC, November 1973 to present.
17. ---, *Advanced Design Composite Aircraft (ADCS) Study*, Grumman Aerospace Corporation, work in progress under Contract F33615-75-C-3123, for Air Force Flight Dynamics Laboratory, AFSC, Wright-Patterson Air Force Base, Ohio, April 1, 1975.
18. ---, *Advanced Design Composite Aircraft (ADCS) Study, Final Report*, AFFDL-TR-76-10, Rockwell International Corporation, under Contract F33615-75-C-3157, for Air Force Flight Dynamics Laboratory, AFSC, Wright-Patterson Air Force Base, Ohio, March 1976.
19. Composite design concepts applied to the B-1 aircraft; contracts in progress for Air Force Flight Dynamics Laboratory (AFFDL/FBB), AFSC, Wright-Patterson Air Force Base, Ohio:
 - a. *Advanced Development of Conceptual Hardware*, Grumman Aerospace Corporation, Contract F33615-73-C-5173, June 1973 to November 1976.

- b. *Development of a Low-Cost Composite Vertical Stabilizer*, Los Angeles Aircraft Division of Rockwell International Corporation, Contract F33615-74-C-5164, October 1974 to April 1977.
 - c. *Composite, Low-Cost Secondary Airframe Structures*, Los Angeles Aircraft Division of Rockwell International Corporation, Contract F33615-74-C-5111, May 1975 to September 1976.
 - d. *Production Validation/Composite Secondary Airframe Structure*, Los Angeles Aircraft Division of Rockwell International Corporation, Contract F33615-75-C-5177, May 1975 to September 1976.
- 20. ---, "Aerospace Materials, Special Report," *Aviation Week and Space Technology*, Vol. 104, No. 4, January 26, 1976, pp. 42-131.
 - 21. Harris, L. A., "Advanced Composites: An Assessment of the Future," *Aeronautics and Astronautics*, March 1976, pp. 22-34.
 - 22. Krueger, Charles H., Jr., *A Computer Program for Determining the Reflection and Transmission Properties of Multilayer Plane Impedance Boundaries*, AFAL-TR-67-191, Air Force Avionics Laboratory, AFSC, Wright-Patterson Air Force Base, Ohio, September 1967.
 - 23. Penton, A. P., and J. L. Perry, *The Effects of High Intensity Electrical Currents on Advanced Composite Materials*, Philco-Ford Corporation, with K. J. Lloyd of General Electric, Report No. U-4866, for Naval Air Systems Command, September 15, 1970.
 - 24. Quinlivan, J. R., et al., *Coatings for Lightning Protection of Structural Reinforced Plastics*, AFML-TR-70-303PT, Boeing Aerospace Company, for Air Force Materials Laboratory, AFSC, Wright-Patterson Air Force Base, Ohio, March 1971.
 - 25. Leeds, Maurice, A., *Handbook of Electronic Materials: Vol. 9, Electronic Properties of Composite Materials*, Plenum Publishing Corporation, New York, 1972.
 - 26. Fisher, F. A., *Lightning Effects Relating to Aircraft: Part I, Lightning Effects on, and Electromagnetic Shielding Properties of, Boron and Graphite Reinforced Composite Materials*, General Electric Company, with W. M. Fassell of Philco-Ford, AFAL-TR-72-5, for Air Force Avionics Laboratory, AFSC, Wright-Patterson Air Force Base, Ohio, January 1972.
 - 27. Van Fo Fy, G. A., *Electromagnetic Field in Fiber Composites*, FTD-HT-23-1381-72, Foreign Technology Division, Wright-Patterson Air Force Base, Ohio, October 1972.

28. ---, *Lightning and Static Electricity Conference*, AFAL-TR-72-325, Air Force Avionics Laboratory, AFSC, Wright-Patterson Air Force Base, Ohio, December 1972.
29. ---, *1975 Conference on Lightning and Static Electricity*, 14-17 April 1975, Culham Laboratories, England; proceedings sponsored by Royal Aeronautical Society, SAE and IEE, 4 Hamilton Place, London W1VOBQ, England.
30. Perry, J. O., and R. L. Miller, *The Effects of High Intensity Electrical Currents on Advanced Composites*, Philco-Ford Corporation, with K. E. Crouch of General Electric, Report No. U-6007, for Naval Air Systems Command, March 1973.
31. Schmitt, George F., Jr., *Fluoroelastomer Coatings Resistant to Thermal Flash, High Temperature, and Subsonic Rain Erosion*, AFML-TR-74-25, Air Force Materials Laboratory, AFSC, Wright-Patterson Air Force Base, Ohio, April 1974.
32. Plumer, J. A., et al., *Lightning Effects on the NASA F-8 Digital Fly-by-Wire Airplane*, SRD-74-090, General Electric Company, for Flight Research Center, NASA, May 1974.
33. Kim, E. G., G. A. DuBro, and R. C. Beavin, *Measurement of Advanced Composite Materials Shielding Effectiveness*, AFFDL-TR-74-30, Air Force Flight Dynamics Laboratory, AFSC, Wright-Patterson Air Force Base, Ohio, June 1974.
34. Walko, L. C., *Current Status of Composites Vulnerability to Lightning*, SRD-74-090, General Electric Company, for Air Force Flight Dynamics Laboratory, AFSC, Wright-Patterson Air Force Base, Ohio, August 1974.
35. Hiebert, A. L., and S. A. Scharff, *An Electromagnetic Compatibility Program for the 1970s (Selected Issues)*, R-1114/1-PR, The Rand Corporation, August 1974.
36. Bogdanor, J., R. A. Pearlman, and M. D. Siegel, *Intrasystem Electromagnetic Compatibility Analysis Program (IEMCAP)*, RADG-TR-74-342, McDonnell Aircraft Company, for Rome Air Development Center, AFSC, Griffiss Air Force Base, New York, December 1974.
37. Hiebert, A. L., *An Intrasystem Analysis Program (IAP): Appendix to R-1114/1-PR*, R-1690/1-PR, The Rand Corporation, July 1975.
38. Chase, Vance A., *Investigation of Reinforced Plastics for Naval Aircraft Electromagnetic (EM) Windows*, MJO-3043, Whittaker Corporation, for Naval Air Systems Command, January 1975.
39. Moorefield, A. A., et al., *Manufacturing Methods for Advanced Radome Production*, IR-492-4(III), Brunswick Corporation, for Air Force Materials Laboratory, AFSC, Wright-Patterson Air Force Base, Ohio, February 1975.

40. ---, *Advanced Development of Conceptual Hardware Horizontal Stabilizer: Lightning Strike Test Report*, Report No. AC 75.5, Grumman Aerospace Corporation, for Air Force Avionics Laboratory, AFSC, Wright-Patterson Air Force Base, Ohio, April 1975.
41. ---, *Survivable Flight Control System (SFCS) Electrical Hazard Protection*, Project No. 2090, Task 2, Air Force Flight Dynamics Laboratory (FGA), AFSC, Wright-Patterson Air Force Base, Ohio, April 1975.
42. ---, *Vulnerability/Survivability of Composite Structures to Lightning Strike*, Boeing Aerospace Company, Seattle, Washington, work in progress under Contract F33615-75-C-5255, for Air Force Flight Dynamics Laboratory (FBC), AFSC, Wright-Patterson Air Force Base, Ohio, June 15, 1975.
43. Strawe, D., and L. Piszker, *Interaction of Advanced Composites with Electromagnetic Pulse (EMP) Environment*, AFML-TR-75-141, Boeing Aerospace Company, for Air Force Materials Laboratory, AFSC, Wright-Patterson Air Force Base, Ohio, September 1975.
44. Walker, W., et al., *A Technology Plan for Electromagnetic Characteristics of Advanced Composites*, RADC-TR-76-206, Rome Air Development Center (RBCT), AFSC, Griffiss Air Force Base, New York, July 1976 (AD-A030507).
45. Skouby, C. D., *Electromagnetic Effects of Advanced Composites*, NR-213-121, McDonnell Douglas Corporation, St. Louis, Missouri, ONR Contract No. N00014-74-C-0200, January 1975.
46. ---, *Lightning Test Waveforms and Techniques for Aerospace Vehicles and Hardware*, Society of Automotive Engineers, SAE Committee AE4, Special Task F, 400 Commonwealth Drive, Warrendale, Pennsylvania, May 5, 1976.
47. Schwartz, H. S., and W. F. Bahret, *Radar Reflection, Absorption, and Transmission of Boron Fiber Reinforced Plastics*, Project No. 7340, Task 734003, Air Force Materials Laboratory (AL), AFSC, Wright-Patterson Air Force Base, Ohio, September 1966.
48. Almon, M., L. McCrory, and J. Delmonte, "Behavior of Composites under Cyclic Stress in the Presence of Water," Delsen Corporation Testing Laboratories, Glendale, California (paper presented at the SPE Meeting, September 16-18, 1975, Las Vegas, Nevada).