

AD-A042 179

CONSTRUCTION ENGINEERING RESEARCH LAB (ARMY) CHAMPAI--ETC F/G 13/13  
SHIPPING CONTAINERS AS STRUCTURAL SYSTEMS.(U)  
JUL 77 E L MCDOWELL

UNCLASSIFIED

CERL-TR-C-77

NL

1 OF 1  
ADA  
042179



END

DATE  
FILMED  
8-77

12

construction  
engineering  
research  
laboratory

TECHNICAL REPORT C-77  
July 1977  
Shipping Containers as Structural Elements

SHIPPING CONTAINERS AS STRUCTURAL SYSTEMS

ADA 042179

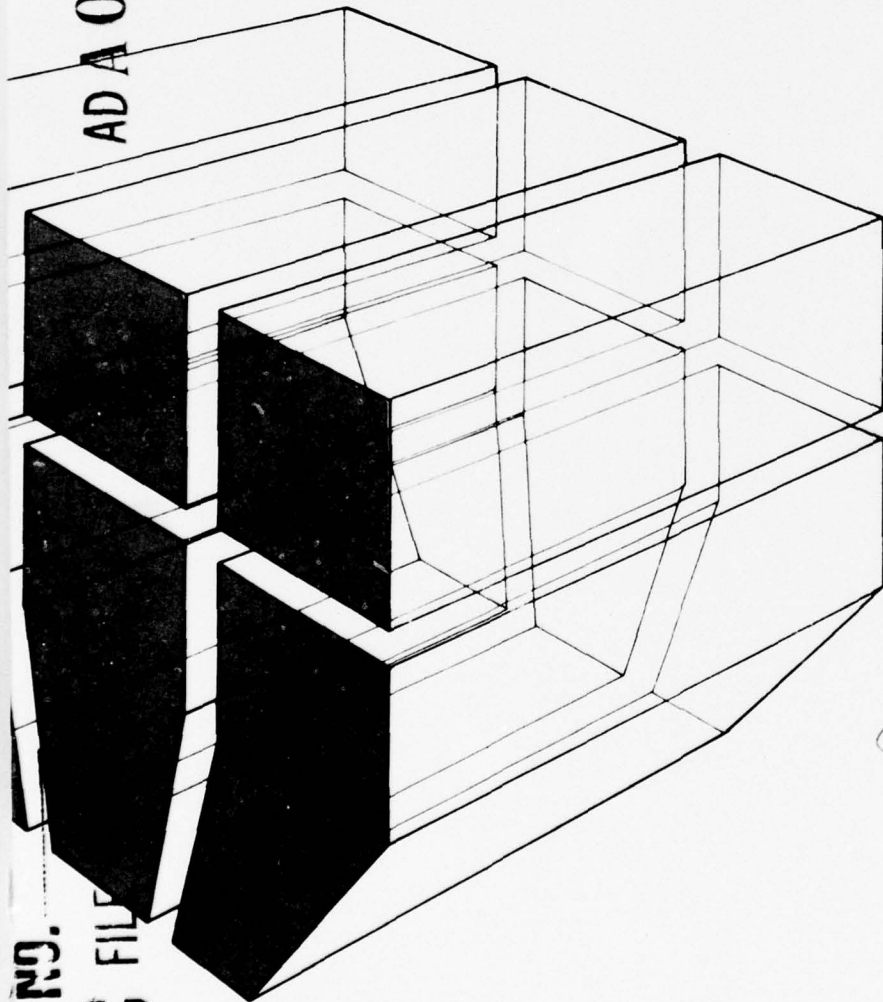

by  
E. L. McDowell

DDC  
RECEIVED  
JUL 28 1977  
RESERVED  
E

*[Handwritten signature]*



ADJ NO.  
DDC FILE

The contents of this report are not to be used for advertising, publication, or promotional purposes. Citation of trade names does not constitute an official indorsement or approval of the use of such commercial products. The findings of this report are not to be construed as an official Department of the Army position, unless so designated by other authorized documents.

*DESTROY THIS REPORT WHEN IT IS NO LONGER NEEDED  
DO NOT RETURN IT TO THE ORIGINATOR*

| REPORT DOCUMENTATION PAGE   |   | READ INSTRUCTIONS<br>BEFORE COMPLETING FORM  |
|---|---|--|
| 1. REPORT NUMBER<br>14 CERL-TR-C-77   | 2. GOVT ACCESSION NO.   | 3. RECIPIENT'S CATALOG NUMBER  |
| 4. TITLE (and Subtitle)<br>6 SHIPPING CONTAINERS AS STRUCTURAL SYSTEMS  | 5. TYPE OF REPORT & PERIOD COVERED<br>9 FINAL rept.   | 6. PERFORMING ORG. REPORT NUMBER   |
| 7. AUTHOR(s)<br>10 E. L./McDowell   | 8. CONTRACT OR GRANT NUMBER(s)<br>17 44   | 9. PERFORMING ORGANIZATION NAME AND ADDRESS<br>CONSTRUCTION ENGINEERING RESEARCH LABORATORY<br>P.O. Box 4005<br>Champaign, IL 61820                            |
| 10. PROGRAM ELEMENT, PROJECT, TASK AREA & WORK UNIT NUMBERS<br>16 4A763734DT34-04-001<br>4A664927D895   | 11. CONTROLLING OFFICE NAME AND ADDRESS<br>12 34p.  | 12. REPORT DATE<br>11 July 1977  |
| 13. MONITORING AGENCY NAME & ADDRESS (if different from Controlling Office)   | 14. SECURITY CLASS. (of this report)<br>Unclassified  | 15. NUMBER OF PAGES<br>32  |
| 16. DISTRIBUTION STATEMENT (of this Report)<br>Approved for public release; distribution unlimited  | 15a. DECLASSIFICATION/DOWNGRADING SCHEDULE<br>ACCESSION for<br>NTIS White Section <input checked="" type="checkbox"/><br>DDC Buff Section <input type="checkbox"/><br>UNANNOUNCED <input type="checkbox"/><br>JUSTIFICATION<br>BY<br>DISTRIBUTION/AVAILABILITY CODES<br>This report is SPECIAL<br>A | 17. DISTRIBUTION STATEMENT (of the abstract entered in Block 20, if different from Report)   |
| 18. SUPPLEMENTARY NOTES<br>Copies are obtainable from National Technical Information Service<br>Springfield, VA 22151   | 18. SUPPLEMENTARY NOTES   | 19. KEY WORDS (Continue on reverse side if necessary and identify by block number)<br>shipping containers<br>T/O structural systems<br>dual-purpose containers |
| 20. ABSTRACT (Continue on reverse side if necessary and identify by block number)<br>This report investigated the feasibility of (1) using shipping containers (MILVAN) as structural elements in the construction of theater of operations (T/O) facilities, and (2) using dedicated containers in the T/O for the dual purpose of logistics and shelter.<br>Mathematical structural modeling via finite element analysis, laboratory tests, and field tests were used to validate the concept of using shipping containers as structural elements | 20. ABSTRACT  | 19. KEY WORDS  |

405 279

NEXT PAGE →

Block 20 continued.

in the construction of T/O facilities. The most effective configuration was an 80-ft (24-m) box beam configuration formed by joining four MILVANS end to end. Used as a roof system, these box beams and the facilities constructed from them meet wind and snow design loads encountered at any location in the world. For a typical logistic port base study exercise, facilities constructed from shipping containers showed an actual savings of \$2.3 million and 1.5 battalion months of engineering effort over steel-framed Army Facilities Component System (AFCS) facilities.

UNCLASSIFIED

## FOREWORD

This project was performed by the Facility Systems Branch (FOS), Facility Operations Division (FO), of the U. S. Army Construction Engineering Research Laboratory (CERL) for the Directorate of Facilities Engineering, Office of the Chief of Engineers (OCE).

The research was initiated under Project 4A664717D895, "Military Construction System Development," and completed under Project 4A763734DT34, "Development of Engineer Support to the Field Army"; Task 04, "Base Development"; Work Unit 001, "Shipping Containers as Structural Elements." The OCE Technical Monitor for this study was Mr. R. H. Barnard.

COL J. E. Hays is Commander and Director of CERL, and Dr. L. R. Shaffer is Technical Director. Mr. R. Colver is Chief of FOS, and Mr. R. Blackmon is Chief of FO.

## CONTENTS

|   |           |
|---|-----------|
| DD FORM 1473  | 1         |
| FOREWORD  | 3         |
| LIST OF TABLES AND FIGURES  | 5         |
| NOTICE  | 6         |
| <b>1 INTRODUCTION</b> . . . . .                                     | <b>7</b>  |
| Background  |           |
| Purpose   |           |
| Approach  |           |
| Mode of Technology Transfer   |           |
| <b>2 ANALYTICAL STUDIES</b> . . . . .                               | <b>8</b>  |
| Finite Element Model for Single Container                           |           |
| Matrix Reduction for Single Container                               |           |
| Box Beam Roof System  |           |
| <b>3 LABORATORY TESTS</b> . . . . .                                 | <b>9</b>  |
| The CERL Structural Load Floor                                      |           |
| Loading Procedure   |           |
| Experiments with DARCOM Coupler                                     |           |
| Experiments with CERL Coupler                                       |           |
| Comparison to Analytical Studies                                    |           |
| Test Results  |           |
| <b>4 FIELD TESTS</b> . . . . .                                      | <b>11</b> |
| Construction Techniques   |           |
| Loading Procedures  |           |
| Endurance Tests   |           |
| Test Results  |           |
| <b>5 DEDICATED CONTAINERS</b> . . . . .                             | <b>13</b> |
| Containerized Model TOE   |           |
| Habitability Components   |           |
| Typical Site Layout   |           |
| <b>6 BASE DEVELOPMENT APPLICATION</b> . . . . .                     | <b>14</b> |
| Scenario  |           |
| Container Requirements and Availability                             |           |
| Impact on Engineering Effort  |           |
| <b>7 SUMMARY AND CONCLUSIONS</b> . . . . .                          | <b>16</b> |
| Summary   |           |
| Conclusions   |           |
| APPENDIX A: Economic Impact on Base Development                     | 17        |
| APPENDIX B: Construction Procedures for Shipping Container Facility | 23        |
| REFERENCES  | 32        |
| DISTRIBUTION  |           |

## TABLES

| Number |   | Page |
|--------|---|------|
| A1     | TOE Assignments to Base II-8                            | 18   |
| A2     | Shelter Facilities, Phase 5, D+61 to D+90 Days          | 19   |
| A3     | Summary of Containerized Working Tonnages               | 21   |
| A4     | Candidate Facilities for Base II-8                      | 21   |
| A5     | Cost-Effort Data for Candidate Facilities for Base II-8 | 22   |

## FIGURES

|     |  |    |
|-----|--|----|
| B1  | Foundation Dimensions                                  | 24 |
| B2  | Interior Support Dimensions—MILVANs on End             | 25 |
| B3  | Safety Spacer Construction                             | 25 |
| B4  | Spacer Positioning for Support Construction            | 26 |
| B5  | Alternate Support System                               | 27 |
| B6  | Increased Clear Height, Excavation With Safety Setback | 27 |
| B7  | MILVAN Dimensions With Corner Fitting Configuration    | 28 |
| B8  | Exploded View of MILVAN Coupler                        | 29 |
| B9  | In-Place View of Assembled Coupler                     | 30 |
| B10 | Initial MILVAN Positioning for Box Beam Construction   | 31 |
| B11 | Detail of Work Positioning Pedestal                    | 31 |

## NOTICE

The techniques developed in this report are to comply with DOD Instruction 4500.37. It is not the intent of the research to suggest that containers be removed from the Army's logistics system and used in construction. Only the containers which have been removed from the logistics system by damage or those containers which have been dedicated to facilities construction are considered for use as structural members as developed in this research.

# SHIPPING CONTAINERS AS STRUCTURAL SYSTEMS

## 1 INTRODUCTION

### Background

In the later stages of the Viet Nam operation, 55 to 60 percent of incoming supplies of Classes I, II, III, VI, VIII, and IX were containerized. Many of these containers were commercial containers either 30 or 40 ft (9 or 12 m) long, and modern port facilities with the capability of handling containers of these dimensions could be constructed. In future operations, however, it probably will be neither possible nor desirable to man such large construction tasks; therefore, material handling equipment projections are based on a requirement to handle 20-ft (6-m) containers such as the MILVAN or the Type C ISO container.\*

Army Logistics Center estimates indicate that by 1980, approximately 90 percent of military supplies of Classes I, II, III, V, VIII, and IX will be containerized. Inclusion of Class V (ammunition) supplies in this prediction will result in doubling the daily throughput of containerized supplies. This increase, combined with the restriction to MILVAN size containers, means that the number of containers per man-day in the theater of operations (T/O) will be more than double that experienced in Viet Nam.

Although developed for transport, units such as these may be used as structural elements for T/O construction. This study addresses this secondary consideration of these containers.

### Purpose

The purpose of this study was twofold: (1) to establish the physical and economic feasibility of using shipping containers, i.e., MILVANS, as structural elements in the construction of T/O facilities, and (2) to investigate the feasibility of having dedicated containers in the T/O serve the dual purpose of logistics and shelter.

### Approach

This research was conducted by means of analytical studies, laboratory and field tests, and special studies

\*Since approximately 50 percent of the more than 500,000 containers in the commercial container fleet are of the 20-ft (6-m) size, the restriction to this size does not appear to be detrimental to modern military operations.

relating to dedicated containers and their economic impact in the T/O. Analytical studies (Chapter 2) were the necessary starting point, since design criteria for shipping containers do not include load situations where the container is used as a structural member in facility construction.

The laboratory tests (Chapter 3) served three purposes:

1. The test of a single MILVAN validated use of the finite element structural modeling technique for a single MILVAN, and the test of a box beam constructed of four MILVANS validated the extension of the technique.

2. Laboratory tests permitted rapid and economical investigation of end-result conditions not covered in the analytical studies.

3. Laboratory tests permitted study of the couplers, a subject not previously addressed analytically in a practical manner.

The field tests (Chapter 4) simulated T/O conditions. Using expedient foundations on unprepared sites, a "roof" section approximately 16 by 80 ft (5 by 24 m) was subjected to an endurance test during the adverse weather season. In addition, a 120-ft (36-m) box beam was constructed, which had not been possible in the laboratory.

A detailed substudy of dedicated containers requested by the Office of the Chief of Engineers (OCE) was carried out; Chapter 5 summarizes the important portions of this research.

The economic impact of container-constructed facilities was evaluated by studying a base development application. Chapter 6 summarizes this research, and Appendix A provides complete details of the study.

Chapter 7 provides a summary and conclusions.

### Mode of Technology Transfer

If the concept of using shipping containers as structural elements is approved, a new design will be provided to TM 5-302, *Army Facilities Component System—Designs* (Vol I and Vol II); the supporting information will be included in TM 5-301, *Army Facilities Component System Planning* (all environments) and TM 5-303, *Army Facilities and Component System Logistics Data and Bills of Materials*. The complete

specifications for the coupler will be furnished to the Directorate of Combat Developments, U. S. Army Engineer School, Fort Belvoir, Virginia.

## 2 ANALYTICAL STUDIES

Design criteria for shipping containers are based on normal loads anticipated for the transportation mode. However, when a shipping container is used as a structural element, the loading experienced is unlike that used to develop the design criteria. Moreover, the loads or loadings experienced are difficult to reproduce in the laboratory, thus necessitating a comprehensive analytical study of a shipping container's structural response to loads encountered when it is used as part of a facility.

Initial structural modeling was accomplished via standard finite element techniques; however, the structural complexity of a shipping container required development of matrix reduction procedures so that more than one container could be examined at a time. Use of these reduction procedures enabled structural modeling of entire roof systems constructed of containers.

During the course of the analytical studies, an initial laboratory test was conducted to serve as a check-point in the structural modeling.

### Finite Element Model for Single Container

Developing a finite element model of a MILVAN requires breaking the complicated structural members into smaller and simpler members for which simple linear solutions are known. For the MILVAN, these simpler elements consist of three-dimensional beams and plane-stress triangular plate elements. A structural model consisting of 2268 equations was constructed from the MILVAN specifications;<sup>1</sup> as expected, most of the off-diagonal terms in the equations were zero, leaving not more than 180 terms per equation.

For a given load condition imposed on MILVAN, a computer program called SAP (Generalized Structural Analysis Program by Wilson, et al., University of Cali-

fornia at Berkeley) was used to determine the structural response. Obtaining a solution for each load case required from 5 to 12 minutes on a CDC 6600 computer.

The structural modeling was verified by loading a single MILVAN instrumented with strain gauges in the laboratory. The actual structural response was within 15 percent of the predicted response from the computer runs.

### Matrix Reduction for Single Container

When a group of, for example, four MILVANs are considered together, the number of simultaneous equations which form the stiffness matrix rises to 9144. Unfortunately, the computer run time increases according to a power law rather than linearly, and a conservative estimate of the computer run time per load case would be in hours rather than minutes.

One way of avoiding this excessive computer time is to condense or reduce the stiffness matrix for a single MILVAN. When a MILVAN is used in a facility as a structural element, the only unknown loads (on the MILVAN) are the forces at the eight corners; thus, it should be possible to condense the  $2268 \times 2268$  stiffness matrix to a  $48 \times 48$  stiffness matrix, in which each of the six degrees of freedom for the eight corners are taken into account.

Using a method<sup>2</sup> similar to that proposed by Rosen and Rubinstein,<sup>3</sup> a computer program was written to reduce the stiffness matrix of a multi-degree-of-freedom system to an equivalent stiffness matrix involving fewer degrees of freedom. Since this method uses Cholesky decomposition instead of the more common matrix inversion, it is particularly useful for substructure problems in which many degrees of freedom must be condensed and eliminated. The computer program is most efficient when used for a large degree-of-freedom system with a sparse stiffness matrix. The MILVAN stiffness matrix with 2268 degrees of freedom and a bandwidth of 180 falls within this classification, and the method reduces the MILVAN stiffness matrix to an equivalent  $48 \times 48$  stiffness matrix.

<sup>2</sup>G. Holze, *Stiffness Matrix Reduction for Large Structural Systems Using Cholesky Decomposition*, Interim Report S-24/AD#768721 (U. S. Army Construction Engineering Research Laboratory, October 1973).

<sup>3</sup>R. Rosen and M. Rubinstein, "Substructure Analysis by Matrix Decomposition," *Journal of the Structural Division A.S.C.E.*, Vol 96, No ST3 (March 1970), pp 663-670.

<sup>1</sup>Drawings, Container, Cargo, Code Identification No. 97403-13219 E0000 through -E0020 (U. S. Army Mobility Equipment Command, 1970).

### Box Beam Roof System

The roof system of a facility constructed for shipping containers consists of strings of containers (MILVANS) connected end to end to form box beams of 80, 100, or 120 ft (24, 30, or 36 m) in length, depending on whether four, five, or six shipping containers are used. A structural model of an 80-ft (24-m) box beam was constructed by using the reduced equivalent stiffness matrix for the shipping containers and the  $6 \times 6$  stiffness matrix for a three-dimensional beam to model the couplers at the three sets of corners connecting the containers. The box beam structural model had 288 degrees of freedom, and the net stiffness matrix was relatively sparse.

In this structural model, the individual containers were placed in the inverted position with the floor system on top. In this configuration, the floor system, which is much stronger than the roof system, carried the beam compressive loads, thus averting local buckling of the compressive side of the box beam.

Three sets of end conditions were modeled: (1) pinned at one end and mounted on rollers at the other end, (2) pinned at both ends with zero horizontal reaction under the dead weight of the box beam, and (3) a pinned-rollers combination with a 1-in. (25-mm) settlement of one corner. The pinned-rollers end condition models the laboratory end conditions, while the other two approximately model the end conditions which would arise in a field test.

Each of the three model box beams was loaded with a live load of 60 lb/sq ft (293 kg/m<sup>2</sup>) on the upward facing surface, which was the floor system. The coupler forces were determined from the computer runs. Knowing the coupler forces permitted the determination of all stresses in the full finite element model of the shipping container by additional short computer runs. In all three cases, the maximum predicted stress from the computer run of the finite element model of a single container was less than the allowable design stress for the MILVAN material.

In summary, the analysis of the box beam roof system was a two-step process. First, the reduced stiffness matrices for the individual containers were used to construct a roof model which was analyzed to determine the coupling forces between containers. These coupling forces were then used as loads on a full finite element model of a single shipping container to obtain stresses in the individual structural members.

## 3 LABORATORY TESTS

### The CERL Structural Load Floor

All laboratory tests were performed on the U. S. Army Construction Engineering Research Laboratory (CERL) structural load floor, which is nominally 80 × 120 ft (24 × 36 m), with 3-ft (0.9-m) on-center load points covering a 33 × 96 ft (10 × 29 m) area. Each load point can sustain a maximum load of 60,000 lb (27 000 kg) in any direction. The structural load floor is serviced by a 20-ton (18-t) overhead traveling bridge crane. A static loading system is provided by 10-ton (9-t) jacks and 16-ton (15-t) and 30-ton (27-t) dual-action hydraulic cylinders controlled by a series of manually operated needle- and pressure-relief valves. The floor also has a dynamic loading system consisting of a closed-loop controlled hydraulic system using electrohydraulic activators of 25- and 50-kip (111- and 222-kN) capacity. Instrumentation consists of a wide variety of digital readouts, magnetic tape recorders, and plotters as needed to record readings from strain gauges and deflection transducers. Special loading fixtures can be constructed readily by using the load points on the structural load floor as attachment points.

### Loading Procedure

The test specimen was four-MILVAN (80-ft [24-m]) box girders like the one modeled in Chapter 2. As a safety measure, it was decided that the deflection of the test specimen should be controlled at all times. This was accomplished by a support system supplemental to the pin-roller support of the box girder. The supplemental support system consisted of six hydraulic jacks positioned in pairs at the half and quarter points of the box girder. The hydraulic jacks were connected in parallel so that all jacks carried identical loads. (The lengths of the supply lines and return lines were kept equal for all jacks.)

The box beam was constructed on the structural load floor and lifted into position with the pinned end located on one set of pedestals and the roller end located on an elevated trackway so that the box beam was horizontal. Then a pair of jacks was positioned at each junction of two MILVANS—the quarter and half points of the beam—each at the outer edge of the box girder. When each of the six jacks was positioned, the hydraulic pressure was increased until there was a zero reaction at both the pinned and rolled ends. During this process, the 20-ton (18-t) bridge crane was used as a safety backup by maintaining a slight slack in the chains used to lift the box beam onto the supports.

At this point, the final load was gradually placed on the box beam; it consisted of a layer of 3/4-in. (19-mm) plywood, two layers of 5-in.-thick (127-mm) concrete blocks spanning the width of the box beam, and a series of mid-span concentrated loads totaling 14,800 lb (6700 kg). As each load increment was applied, the hydraulic pressure in the jacks was increased to maintain zero reaction at both the pinned and roller ends.

After load placement was completed, the known weight of the four MILVANS and the final loads were supported by the six hydraulic jacks, thus establishing a calibration point correlating hydraulic pressure and load. In effect, the hydraulic jacks were acting as a scale to measure weight, and adjustment of hydraulic pressure adjusted the value of the end reactions at the pinned and roller ends.

While load was being transferred from the hydraulic jacks to the end supports, the entire assembly was under deflection control. Failure of any component can cause movement or deflection corresponding to the elastic energy stored in the hydraulic fluid; however, since hydraulic fluid is almost incompressible, this elastic energy is minute.

#### Experiments with DARCOM Coupler

The U. S. Army Materiel Development and Acquisition Readiness Command (DARCOM) coupler was designed to connect commercial 40-ft (12-m) shipping containers. The coupler is of a clamshell design with a screw mechanism to open and close the two arms forming the clamshell. Two MILVANS are placed end to end with a 3-in. (76-mm) gap between; in each of the four adjacent sets of MILVAN corner fittings, the arms of the clamshell coupler are inserted into the outer holes and tightened into place with the screw mechanism. The coupler has built-in stops to maintain the 3-in. (76-mm) gap.

The construction of a box beam with the DARCOM clamshell coupler is merely an extension of the concept of coupling two MILVANS. The essential difference is that the MILVANS are first inverted to bring the MILVAN floor system to the top to take the compressive load.

Box beam construction began with placement of four inverted MILVANS end to end on the structural load floor with approximately 3-in. (76-mm) gaps between ends. Two MILVANS were connected to form an inverted 40-ft (12-m) module. Then additional inverted MILVANS were connected with the clamshell connectors until the approximately 80-ft (24-m) box beam

was completed. Since the clamshell connectors were each rated at 38 kips (169 kN) in tension, the resulting box beam should have been able to sustain an equivalent roof load of approximately 58 lb/sq ft (283 kg/m<sup>2</sup>) in addition to the dead weight of the MILVANS, providing coupler failure was the only mode of failure.

Seven attempts were made to load the box beam to its design load of 50 lb/sq ft (244 kg/m<sup>2</sup>) on the upper surface. The first two coupler failures occurred during attempts to lift the box beam onto its pedestals; in each case, the broken couplers were replaced and, on the third try, the box beam was successfully positioned. Load positioning and increasing hydraulic pressure in the jacks completed preparations for testing the box beam. As load was being transferred to the box beam, the two center couplers failed at an effective uniform load of 9 lb/sq ft (44 kg/m<sup>2</sup>). At this box beam loading, the center couplers were sustaining a tensile load of approximately 17 kips (76 kN) or approximately 45 percent of their rated loads.

Four more attempts to load the box beam (i.e., replacing couplers and reloading) were tried. In none of these instances did the box beam with the clamshell couplers support its own dead weight. At this point, researchers suspended further testing of the box beam using clamshell couplers and decided to design and fabricate a new coupler.

#### Experiments with CERL Coupler

After several months, a CERL coupler was designed and fabricated so that the laboratory tests could proceed. The coupler consisted of two clips (see Figure B8, Appendix B) held in place by oak wedges driven between the clips in the gap between MILVANS. The test setup on the structural load floor was reconstructed, and pre-positioned loads were placed on the MILVAN box beam.

Loading of the box beam by reduction of hydraulic jack pressure was completed without apparent failure of the CERL coupler; an equivalent roof load of 56 lb/sq ft (273 kg/m<sup>2</sup>) had been reached. The box beam was then unloaded (i.e., pre-positioned load transferred to the hydraulic jacks) and the center lower couplers were removed for inspection. This inspection revealed several small cracks at the clip notch; it is estimated that approximately 80 percent of the load capacity of this particular clip configuration had been reached and that an equivalent roof load of 70 lb/sq ft (342 kg/m<sup>2</sup>) could have been attained.

New coupler clips were placed in the center lower position between MILVANs, and a second loading schedule was started. One of the pinned ends was given a preset deflection of 1 in. (25 mm); thus, when the pre-positioned load was transferred to the box beam, a combination of twisting and roof load was applied to the box beam. Inspection of the coupler loading revealed approximately the same results found in the first test. This load schedule completed the laboratory test program and indicated that the CERL coupler, while marginally meeting the load requirements, could be upgraded to a much higher capacity by a clip-locking procedure that would prevent the clip's ends from deflecting inward (see Figure B8, Appendix B).

#### Comparison to Analytical Studies

Two comparisons were made between experimental and analytical studies. In the first, a single MILVAN had been positioned on the structural load floor so that it could be loaded in the plane of the bottom corner fittings. The main longitudinal beams of the MILVAN floor system were fitted with strain gauges on both ends. The structural floor system of the MILVAN was placed in longitudinal compression by means of horizontal hydraulic jacks. At a compressive load equivalent to coupler loadings of 60 kips (267 kN), there was no indication of local buckling of any MILVAN structural membranes; the strain gauge readings indicated that the induced stress level was less than one-third the material yield stress, which corresponded to the result of the finite element analysis. Since a coupler loading of 60 kips (267 kN) corresponds to a box beam loading of more than 50 lb/sq ft (244 kg/m<sup>2</sup>), this test verified that the concept of using the MILVAN floor system as the compressive side of a box beam is viable.

The second comparison to the analytical studies involved placing strain gauges on the main roof structural members of four MILVANs while they were inverted and connected to form an 80-ft (24-m) box beam. The first experimental data point was obtained from the best test with the clamshell couplers, in which an equivalent roof load of 9 lb/sq ft (44 kg/m<sup>2</sup>) was reached. The induced stress on the main roof structural members of the MILVANs (the tension side of the box beam) was within 5 percent of the stress predicted by the finite element analysis of the box beam. The remaining data points were taken from laboratory tests run with CERL-designed couplers used to form the box beam. In these tests, where all of the pre-positioned load was successfully transferred to the box

beam, an equivalent roof loading of 58 lb/sq ft (283 kg/m<sup>2</sup>) was reached. Several data points ranging from 9 to 58 lb/sq ft (44 to 283 kg/m<sup>2</sup>) loadings were compared to the predicted values of the finite element analysis of the box beam; the predicted values differed from the experimental values by at most 15 percent. Within experimental error, the experimental values varied linearly with all loads up to the peak load, which corresponded to 75 percent of the yield stress.

#### Test Results

The laboratory test program had three major results. First, it was found that for the 80-ft (24-m) box beam constructed in the laboratory, the stress-history of all MILVAN structural components was always well within the elastic range of the structural material; thus, all MILVAN dimensional tolerances remained true.

Second, the test with deflection of 1 in. (25 mm) of one corner of the box beam indicates that shipping container structures can be constructed on a field-expedient foundation, since the box beam has a large torsional flexibility.

Finally, the tests demonstrated that it is possible to design a coupler that permits joining of MILVANs into useful structural complexes. The CERL coupler, although having marginal capabilities in the configuration used, is an example.

## 4 FIELD TESTS

Two types of field tests were performed over a period of several months. The first type emphasized construction techniques, including construction on an expedient foundation rather than on a prepared surface such as the structural load floor. Also considered were the construction of box beams of lengths other than 80 ft (24 m) and a modification of the locking mechanism of the clips on the CERL coupler. The first type of field test was conducted approximately 1 ft (0.3 m) off the ground for convenience and safety.

The second type of field test, which was designed to be representative of actual T/O construction, involved a MILVAN support system on an expedient foundation and an endurance test under adverse weather conditions.

#### Construction Techniques

In contrast to construction of box beams on a prepared surface such as the structural load floor, construction in the field requires much more effort to

maintain alignment when couplers are inserted. The site selected for the field tests had once been farmland; however, for several years prior to the tests it had been unused, and there had been no site improvement either before or during the field tests. Expedient foundations of 4 and 12 ft (1.2 and 3.6 m) in length were constructed of 4 × 12 in. (102 × 305 mm) timbers; these timbers were also used to establish a construction site for the box beams.

Appendix B provides detailed construction techniques for an 80-ft (24-m) box beam, which entails the use of a 20-ton (18-t) crane. For the field tests at CERL, only a 10-ton (9-t) crane was available, which was just marginal for the tests conducted about 1 ft (0.3 m) off the ground. An 80-ft (24-m) box beam was constructed for load tests, and a 120-ft (36-m) box beam was constructed for demonstration purposes. The 120-ft (36-m) box beam was constructed as an 80-ft (24-m) end-supported beam; 20-ft (6-m) cantilever sections were then added at each end. Each end was then lifted while the timber support system was moved to the ends of the 120-ft (36-m) box beam. As constructed, the end conditions for both the 80- and 120-ft (24- and 36-m) box beams were between pinned-roller (of the laboratory tests) and pinned-pinned; it was anticipated that the highest internal stresses in the MILVAN would be less than the highest internal stresses measured during the laboratory tests. The CERL coupler clips were locked in place with oak wedges in contrast to the scheme given in Appendix B. The method discussed in Appendix B was used for the endurance tests.

#### Loading Procedures

For the tests conducted at a low level (approximately 1 ft [0.3 m] off the ground), only the 80-ft (24-m) box beam had a planned loading. As a loading, three MILVANS were placed along the box beam with the middle MILVAN centered; a concentrated load of 14,800 lb (6700 kg) was then centered on the middle MILVAN load. This loading yielded a center bending moment on the box beam equivalent to 56 lb/sq ft (273 kg/m<sup>2</sup>) roof loading.

The 120-ft (36-m) box beam was not given any additional load, since its center deflection due to its own weight was approximately 9 in. (229 mm), thus limiting its usefulness as a structural member.

Several rain storms occurred during these tests, causing an accumulation of approximately 1 in. (25 mm) of water in each inverted MILVAN. This seepage through

the floor system was equivalent to a 5 to 6 lb/sq ft (24 to 29 kg/m<sup>2</sup>) loading in addition to the planned loading.

#### Endurance Tests

The endurance tests consisted of two side-by-side 80-ft (24-m) box beams supported on MILVANS laid on their sides to provide supporting columns. The only foundation preparation was the use of the timbers to approximately level the supporting MILVANS; the torsional flexibility of the 80-ft (24-m) box beams was sufficient to compensate for any unevenness of the support system. The "roof" covered an area which was approximately 16 × 80 ft (5 × 24 m). The tests were scheduled from September 1974 to May 1975 during the adverse weather seasons.

At the time the test was initiated, the CERL coupler had evolved into the configuration given by Figure B8 of Appendix B, and this configuration was used for the endurance tests. With this configuration, it was possible to lift the 80-ft (24-m) box beam at its center point only; a 20-ton (18-t) crane was required. No connections were made between the box beams and the supporting MILVANS; this was a gravity-type structure where the weight of the members held them in place. In addition, there was no type of positive connection used between the supporting MILVANS and the expedient foundation.

The loading during the endurance test was the typical weather environment of the Central Illinois plains. On several occasions, wind gusts of up to 85 mph (136 km/hr) from various directions were experienced, a severe ice storm occurred, and as much as 26 in. (660 mm) of snow accumulated. Because of the thaw and freeze cycle, the seepage through the floor system accumulated in the interior of the containers to a depth of approximately 8 in. (203 mm) (this amount of water was found after disassembly of the box beams), or an additional dead load of 42 lb/sq ft (205 kg/m<sup>2</sup>). The dead load of the containers alone was 36 lb/sq ft (176 kg/m<sup>2</sup>).

#### Test Results

The results of the field test confirmed the results of the laboratory tests and, in addition, verified that cyclic loading, as in the endurance test, does not deteriorate the integrity of the couplers used to construct the box beam. Dismantling the low-level, 80-ft (24-m) box beam revealed that none of the coupler clips showed any visible signs of permanent damage; in addition, a dye-etch solution applied to the center coupler clips did not reveal any incipient cracks.

Dismantling the box beams used for the endurance testing revealed no evidence of permanent damage to the CERL coupler, either from the weather or from cyclic loading. Some rusting of wedge components of the coupler was evident, but all components were as tight as they had been at the beginning of the tests.

Approximately 8 in. (203 mm) of water had accumulated in each container due to seepage through the container floor system, even though a complete undercoating had been given to each container prior to the test. Drainage and drying out of the container did not reveal any water damage to the container or its internal lashing system. No strain gauges were applied to the containers themselves, since researchers believed that the laboratory tests were conclusive concerning the containers' capability to sustain the loads. Visual inspection for signs of permanent deformation confirmed this conclusion.

## 5 DEDICATED CONTAINERS

This portion of the study was initiated by establishing a baseline case for which a model Table of Organization and Equipment (TOE) was containerized by considering mobility as the sole criterion. Using this baseline case, container interiors were modified and habitability components were developed to establish a family of dedicated containers. Various site layouts were developed to further enhance the shelter aspects of dedicated containers.

### Containerized Model TOE

The Engineer Construction Battalion organized under TOE 3-115, with the attachment of Engineer Support Company, TOE 5-114G, has a mission for base development in the communications zone and in the rear areas of the combat zone. The attachment of TOE 5-114G gives the battalion the capabilities of large-scale quarrying and crushing operations, major reconstruction of railroads and railway bridges, and major protective construction, as well as enhancing its basic capabilities. The duration of employment of this portion of the battalion at a particular assignment, together with its concurrent operations at more than one location for the same assignment, make it a prime choice for containerization, which would enhance both its mobility and capabilities. For these reasons, the Engineer Support Company, TOE 5-114G, was selected to serve as a model TOE.

The Engineer Support Company consists of a company headquarters, an asphalt platoon, a maintenance platoon, and a quarry platoon. Unit integrity for each platoon (G-level TOE was the highest available for this study) was a major criterion in determining the packing schedule of the "Equipment Allowance." Other criteria for the packing schedule were that it should approximate both 70 percent of the available cubage and 70 percent of the weight capacity, but that in no case should it exceed 85 percent of the cube or weight allowance. Initially, a lesser utilization than approximately 70 percent had been considered necessary to maintain unit integrity (at the platoon level), but this proved to be untrue.

The baseline containerization of the model TOE for mobility only was accomplished by considering each line number in the "Equipment Allowance" for TOE 5-114G, ascertaining its weight and cubage from available catalogs, and associating the line item with a particular platoon. At the end of the analysis, all line items were either containerized or stowed in vehicles attached to the model TOE; thus, the unit was 100 percent mobile if transportation for containers was available in the T/O. Twenty containers, most of which achieved at least 70 percent of weight capacity and approximately 70 percent of cubage capacity, were required to achieve this 100 percent mobility.

### Habitability Components

Placing the shipping container on the table of "Equipment Allowances" makes it a "dedicated container" which is always available to the unit; thus, it can function in two modes: (1) a logistic mode when the unit moves from place to place, and (2) a shelter mode when the unit is performing its mission. For such a dual-role container, it is rational to make modifications and additions to ease the transition from one mode to the other. Two approaches to these modifications and additions were followed in this analysis.

In the first approach, the habitability components (desk, work-tables, and bunks) were permanently attached to their shelter mode location and folded against the sides of the container when the logistic mode was employed. Lighting and electrical wiring was built into the container so that a simple connection to an outside source would supply the required power.

In the second approach, the habitability components were stored in the upper 6 in. (152 mm) of the cargo

space; when the cargo was removed, the habitability components were removed from their storage location and placed in their shelter configuration. Built-in lighting and wiring were also contemplated in this approach, but a simpler version was prescribed.

Both approaches require that the cargo restraint system be changed from horizontal to vertical rails, a proven system used commercially in the trucking and railroad industries. In the first approach, however, extensive modification of the commercial cargo restraint system would be required to accommodate the necessary hinges and habitability component restraints. The second approach, in which the habitability components are stored in the usually unused upper 6 in. (152 mm) of cargo volume, does not require any modifications of a vertical cargo restraint system, which uses steel strapping for cargo lashing. When steel strapping is used for cargo lashing, movable strap restraints are fitted to the vertical rails and can be used as restraints for the habitability components.

A full-scale mock-up of a portion of a MILVAN interior was constructed using a commercial vertical cargo restraint system. Four habitability components—two bunks, one desk, and one worktable—were designed and constructed. The methods of storage and attachment in the shelter configuration were designed as part of the habitability component, and no modification of the cargo restraint system was required. The full-scale mock-up verified the concept of the dedicated container and established that conversion from cargo mode to shelter mode or vice versa could be accomplished in less than 30 minutes.

Of the two approaches, the second, which has overhead storage of habitability components and does not require modification of the cargo restraint, is preferable. The first, or fold-out, approach, not only requires modification of the cargo restraint system, but also intrudes on the available cargo floor space, causing a loss of approximately 8 percent of cargo capacity floor space. With the preferred overhead storage type of dedicated container, the model TOE can be containerized with 21 rather than 20 containers; the additional container is required to accommodate redistribution of high-bulk items which, according to the baseline packing schedule, had intruded into the upper 6 in. (152 mm) of a few containers.

#### Typical Site Layout

Dedicated containers can be enhanced as shelters by considering the entire site layout and the integrated

canvas structural extension. For example, the Maintenance Platoon (46 personnel) is assigned six dedicated containers under the proposed "Equipment Allowance." Within these six containers, it is possible to provide bunking arrangements for all 46 personnel and to provide 13 work stations to be fitted with either desk or worktable components. One container could be set up with sleeping accommodations for the platoon leader and his Warrant Officer plus work stations (desks) for all four supervisory personnel, thus preserving unit integrity. Similar container assignments could be made for the remaining personnel.

It is possible to add a large amount of weather-sheltered and housekeeping space at the very moderate cost of integrated canvas structural extensions. The six containers of the maintenance platoon can be positioned in two adjacent rows of three, with doors facing each other approximately 25 ft (8 m) apart. This leaves a common area of approximately 600 sq ft (56 m<sup>2</sup>) accessible to all containers which, when covered with canvas, forms a weather-sheltered and housekeeping space. This space can be used as a maintenance or mess area. End flaps could be provided to further upgrade this common area.

If the integrated canvas structural extensions are constructed in modular form, for example, an 8 × 20 ft (1.4 × 6 m) tarpaulin with grommets in place, there is ample space to store one tarpaulin per container. Thus, the maintenance platoon would have sufficient modules to cover the common area. Other site layouts, such as a "checkerboard" with containers and covered areas alternating, would depend on the number of containers dedicated to the unit and unit needs.

## 6 BASE DEVELOPMENT APPLICATION\*

The Base Development Study,<sup>4</sup> conducted by CERL for the U. S. Army Training and Doctrine Command (TRADOC), encompassed five scenarios and 11 possible

\*Appendix A provides a more detailed discussion.

<sup>4</sup>Base Development Study; Vol I: Executive Summary, ACN 21807; Vol II: Base Design, ACN 21807; Vol IV: Electrical Generation and Distribution, ACN 20380; Vol V: Centralized Water Production, Distribution and Disposal, ACN 20381; Vol VI: Vertical Construction, ACN 20383; Vol VIII: Base Maintenance Study, ACN 20518 (TRADOC, 1976).

base locations. Ultimately, one base location in each scenario area was selected for further study. Of these, two were studied in detail—one to establish a base design methodology, and a second to verify this methodology and to serve as a definitive base design. The remaining three base locations served as check points to establish that all special problems could be covered by the base design methodology. The definitive base design, Base II-8 (Scenario II, Location 8) forms the background for applying shipping container facilities in the T/O.<sup>5</sup>

The following sections discuss the basic scenario, the requirements for and the availability of shipping containers for this application, and the impact on engineering effort of the application. For this particular base, a savings of 1.5 battalion months of effort can be achieved by using shipping container facilities.

#### Scenario

Base II-8 is a logistic port base in the general Middle East area. There are 6468 officers and enlisted men, but no construction capability is inherent; thus, almost all the engineering effort is handled on a mission-type basis by other units. Most of the horizontal construction effort is handled in Phase 2, D+4 to D+25 days, and the majority of the vertical construction effort is scheduled in Phase 5, D+61 to D+90 days. The base is anticipated to be in operation from 2 to 5 years. In the vertical construction effort, nearly 1.1 million sq ft (102 000 m<sup>2</sup>) of shelter facilities are to be provided; 89 percent of this area will be either covered warehouse or maintenance shops. Consolidation of warehouse and maintenance shop functions of various units leads to efficiency in both construction efforts (fewer facilities are constructed) and base design (road network is simplified). A minor construction effort is required through D+540 days.

#### Container Requirements and Availability

Consolidation of warehousing and maintenance shop functions between various units sets a requirement for 35 consolidated warehouses and 19 consolidated maintenance shops. The consolidated facilities are to be 80 × 220 ft (24 × 66 m), typified by Army Facilities Component System (AFCS) Facility No. 441114 or Facility No. 441124. (The base development study team had selected Facility No. 441114, a steel-framed building, on the basis that economic value in the T/O is best measured in engineering effort required.)

<sup>5</sup>Base Design.

A shipping container facility having the same square footage (17,000 sq ft [1600 m<sup>2</sup>]) of usable space and the same clear height (16 ft [5 m]) as the AFCS facility requires 148 containers for construction. For each facility, 26 box beams 80 ft (24 m) long are needed for the roof and 44 containers are needed for the roof support system. For the required 54 facilities (35 warehouses and 19 shops), the total number of containers necessary is 7992.

Regarding the availability of containers for this construction effort, there is little possibility that ships will be dispatched only to pick up empty containers. Thus, the base development study team determined that all the containers arrived during the buildup phase would constitute part of the empty container backlog. In addition, it was considered that initial port confusion would cause a supplementary backlog equivalent to 10 days of normal throughput. For this particular base, these two backlogs amount to almost 11,000 empty shipping containers. Part of this backlog—approximately 2000 containers—is necessary to maintain normal T/O port operation, i.e., replacing full containers with empties as a ship is unloaded. The net number of containers available (approximately 9000) exceeds the net number required by a comfortable margin.

#### Impact on Engineering Effort

The two candidate AFCS facilities (no. 441114 and No. 441124) differ only in their structural framing systems. The former is steel-framed, and the latter is wood-framed; both facilities have the same slab foundation and the same interior electrical work. The main differences are that the wood-framed facility is cheaper (\$22,000 versus \$57,000); however, its construction requires more time (7770 versus 5074 man-hours).

The shipping container facility having the same floor area and clear height as the AFCS facilities constructed on the same slab foundation and having the same interior electrical work is cheaper and less labor-intensive than either AFCS facility. The shipping container structure costs only \$13,600 and at the same time reduces the logistic requirement from 185 short tons (168 t) for the AFCS facility to 91 short tons (83 t) for each facility. The labor required is 2720 man-hours for assembly or dismantling almost half the time required for the least labor-intensive AFCS facility.

For logistic Base II-8, the individual economies of the shipping container facility accumulate a net savings

of 1.49 battalion months of engineering effort. Of this savings, 1.09 months are due directly to the decrease in effort necessary to construct the 54 required facilities. The remaining 0.4 month is due to the avoidance of horizontal construction effort for hardstand storage areas for empty containers.

#### Mode of Technology Transfer

Technology transfer of this research will be accomplished through preparation of draft material for a new Technical Manual (TM) dealing with container-constructed facilities. Appendix B presents draft text for a TM which covers facility site preparation, construction site preparation, function of coupler components and individual coupler assembly, details of roof box beam construction, movement and placement of box beams on their support system, and support systems.

## 7 SUMMARY AND CONCLUSIONS

The conclusions of this work are based on the hypothesis that the peacetime doctrine "that containers shall be used only for logistic purposes"<sup>6</sup> will be modified due to wartime exigencies. This hypothesis becomes more viable as more and more Class V supplies (ammunition) become containerized, since these containers tend to be moved as far toward the front line as possible. Moreover, the pace of activity during the initial and buildup phases will create a supply of containers too damaged for logistic use, but suitable for use in constructing facilities.

#### Summary

The concept of using MILVAN-size containers (8 × 8 × 20 ft [2.4 × 2.4 × 6 m]) as structural elements in constructing facilities was studied via mathematical structural models, laboratory tests, and field tests. The mathematical structural models consisted of an ordinary finite element model for a single MILVAN, which was then condensed to a lesser number of degrees of freedom and combined with itself to form a model of a box beam roof system. Several loadings of the roof system were investigated for this model.

<sup>6</sup>*Ownership and Use of Containers for Surface Transportation and Configuration of Shelters/Special-Purpose Vans*, DOD Instruction 4500.37 (Department of Defense, 1973).

The laboratory tests validated both the finite element model of a single MILVAN and the model of the box beam roof system. Field and laboratory tests verified that a facility constructed with MILVANs or like containers could sustain normal service loads in the T/O without damage. A coupler system was developed which initially matched the structural capability of the MILVAN.

A study of dedicated containers was pursued via a model TOE, which was first containerized merely to increase mobility, without considering use of the containers for shelter. The second phase of this study investigated a combination of increased mobility and shelter usage.

Researchers carried out a base development application of facilities constructed from containers, relying heavily on the CERL Base Development Study conducted for TRADOC. The Base Development Study was concerned only with logistic bases, so the results were limited to these bases. The economic value, measured in battalion months of engineering effort, was established for a typical logistic port base in this study.

#### Conclusions

The analytical studies, laboratory tests, and field tests support the conclusion that it is feasible to construct warehouse and/or maintenance shop facilities from shipping containers without damage to the containers.

Container buildings can be disassembled quickly enough to meet "rapid" return times to support logistic system requirements.

The shipping container facility yields a 76 percent cost savings and a 47 percent engineering effort savings as compared to a steel-framed AFCS facility of the same capacity; a comparison to a similar wood-framed AFCS facility yields a 38 percent cost savings and a 65 percent engineering effort savings. For a typical logistic port base, the actual savings are \$2.3 million and 1.5 battalion months of engineering effort in comparison to steel-framed AFCS facilities—a significant cost and manpower savings.

The benefits of dedicated containers for both mobility and shelter are intangibles, e.g., increased efficiency.

## APPENDIX A: ECONOMIC IMPACT ON BASE DEVELOPMENT

### 1 INTRODUCTION

Early in this study it was found that certain shipping container facilities were more cost-effective than comparable AFCS facilities for an intermediate standard of construction. For an initial standard of construction, the shipping container facility concept was shown to be as cost-effective as a commercially available relocatable facility. These results were obtained under the adverse assumption that the containers used as facilities had been diverted from the logistic stream and that an appropriate rental cost had to be assessed.

Since that time, CERL has conducted a Base Development Study for TRADOC in which several DA-authorized logistic base development problems were studied in detail. One of these problems—a logistic port development—appeared to be a likely candidate for use of shipping container facilities due to its duration, size of operation, and quantity of throughput. However, port development could not be considered during the Base Development Study, which was a state-of-the-art study.

This appendix presents the background and scenario for the logistic port. The vertical construction phase of the base development is extended beyond that given in the Base Development Study, and the availability of empty containers is investigated in greater detail. A shipping container facility for warehouse and maintenance shops is developed and compared to the AFCS facilities recommended by the study. A savings of approximately 1.5 battalion months of engineering effort is predicted if the shipping container facility is used.

### 2 BACKGROUND

The Base Development Study for TRADOC was a state-of-the-art study based on specific scenarios. One purpose of the study was to develop and validate a methodology for base design which provided planning detail not available from the Computer Assisted System

for Theater Level Engineering (CASTLE);<sup>7</sup> this objective was met.

The level of detail permitted determination of time-phased engineering effort from the beginning through base completion. Specific AFCS facilities were determined, as well as such factors as miles of road system, localized power requirements, sanitary facilities, and port construction requirements.

Five locations or sites for logistic bases were selected, one from each of the five scenarios. Base III-13, location 13 of the Far East scenario, was used to develop the base design methodology and to provide baseline information to the several associated base development substudies. Base II-8, from the Mid-East scenario, was used to validate the base design methodology, and the analysis contains the most detailed planning information of any base studied. The remaining three bases, which provided check points for the validity of the base design methodology, were examined primarily for unusual or unique features not covered by the methodology.

### 3 SCENARIO FOR BASE II-8

Base II-8 is a logistic port which must provide for storage and throughput of considerable tonnage of all supply classes. Most of the supplies will arrive by sea and will be containerized as much as possible. There is a small airfield at the site which will be upgraded and expanded to handle air cargo by C-130's as well as a moderate amount (65 to 180 sorties) of helicopter traffic.

Base functions include supply support, medical dispensary operations, military police operations (including handling of prisoners of war), maintenance operations (including maintenance of Army aircraft), transportation terminal operations, fire fighting, communications, data processing, utilities operations, and container handling.

The mission of the base is defined by the operations of the units assigned there, the expected throughput of supplies, and the expected sorties of aircraft. Data of

<sup>7</sup>Computer Assisted System for Theater Level Engineering (CASTLE) (Engineers Strategic Study Group, Office of the Chief of Engineers, 1972).

this type were provided by the Army Logistic Center. Table A1 provides a brief listing of assigned TOEs. The total operational personnel assigned to this base is 460 officers and 6008 enlisted personnel.

The base is to be fully operational at D+90 days, although upgrading construction will continue through D+540 days. The minimum life expectancy of the base is 24 months. Construction of the base proceeds by phases; the first four phases are completed by D+60 days and include the major portion of the port construction and all of the horizontal construction contemplated for the life of the base. During the first four phases, all shelter is either attached to the unit or tentage.

Phase 5, from D+61 days to D+90 days, is devoted exclusively (outside of port completion) to completing vertical construction and major mission-oriented shelter facilities. Almost 1.1 million sq ft (102 000 m<sup>2</sup>) of shelter facilities will be provided, many of which are candidates for construction by shipping container.

The remaining construction phases lasting through D+540 days will raise the base standard of living.

**Table A1 (Cont'd)**  
**TOE Assignments to Base II-8**

| TOE No. | Battalion, Company, or Team Name and Sections | Officers   | Enlisted Personnel |
|---------|---|------------|--------------------|
| 12-550  | Pstl Srv Org                                  | 3          | 25                 |
| 12-560  | 4-Hqtr Team                                   | 4          | 35                 |
| 14-500  | 13-Fin Srv Org                                | 26         | 91                 |
| 19-76   | HHD Md Bn                                     | 13         | 39                 |
| 19-77   | Mp Co   | 4          | 182                |
| 19-272  | HHP Mp  | 14         | 51                 |
| 29-102  | HHC Spt                                       | 18         | 74                 |
| 29-114  | Fld Srv Co, Gen Spt                           | 5          | 106                |
| 29-116  | HHC Supply and Srv                            | 19         | 73                 |
| 29-118  | 2-Gen Sply Co, Gen Sp                         | 14         | 337                |
| 29-119  | Repair Parts Supply Co, Gen                   | 6          | 262                |
| 29-124  | Field Srv Gen Support                         | 6          | 284                |
| 29-127  | Hvy Mat'l Supply Co, G                        | 7          | 131                |
| 29-134  | Lt Equip Gen Spt Maint                        | 13         | 249                |
| 29-136  | HHD Maint DS-GS Bn, Army                      | 14         | 49                 |
| 29-137  | Hvy Equip Gen Spt Maint Co                    | 16         | 255                |
| 29-207  | Light Maint Co Direct                         | 7          | 199                |
| 29-403  | Maint Management Det                          | 6          | 20                 |
| 29-404  | Stock Control Co Supp                         | 33         | 105                |
| 29-427  | Maint Co-Direct Spt                           | 18         | 206                |
| 29-550  | Data Processing Unit-Type B                   | 11         | 85                 |
| 29-640  | Cryptologic Spt Team                          | 3          | 27                 |
| 45-510  | Operations Team                               | 13         | 4                  |
| 55-116  | HHC Trans Terminal                            | 23         | 70                 |
| 55-117  | 3-Trans Terminal Srv                          | 21         | 948                |
| 55-118  | 2-Transportation Terminal Trf                 | 10         | 323                |
| 55-458  | Transportation Aircraft Maint                 | 13         | 275                |
| 55-560  | Transportation Srv Team                       | 4          | 8                  |
|         |   | <b>460</b> | <b>6,008</b>       |

**Table A1**  
**Toe Assignments to Base II-8**

| TOE No. | Battalion, Company, or Team Name and Sections | Officers | Enlisted Personnel |
|---------|---|----------|--------------------|
| 3-500   | Chem Svc Org                                  | 1        | 4                  |
| 5-129   | Engr Co, Port Const                           | 13       | 226                |
| 5-510   | Engr Det (Firefighting Teams)                 | 2        | 22                 |
| 5-530   | Engr Det (UTIL)                               | 2        | 50                 |
| 8-600   | Med Det Hqtr                                  | 7        | 10                 |
| 8-620   | Med Det                                       | 10       | 22                 |
| 9-017   | 2 - Ord Co Ammo Ds-Gs                         | 10       | 192                |
| 9-550   | 4 - Ord Det                                   | 12       | 56                 |
| 10-206  | Qm Bn HHC (Petrl op)                          | 24       | 114                |
| 10-207  | Qm Co Petrl Op                                | 5        | 170                |
| 10-477  | Qm Co (Petrl Supply)                          | 5        | 225                |
| 11-367  | Sig Co Tropospheric                           | 6        | 190                |
| 12-66   | HHD P-A-Field Ar                              | 12       | 33                 |
| 12-67   | Personnel Serv Co                             | 7        | 181                |

#### 4 CONSTRUCTION PHASE 5, D+61 to D+90 DAYS

Other than port completion, Construction Phase 5 is devoted to vertical construction of mission-oriented shelter facilities. Table A2 is a breakdown, by square footage, of the shelters scheduled for completion. The numbers in parentheses with each listing in the first column indicate the number of shelters based on con-

sideration of each TOE individually. In many instances, shelters can be consolidated by grouping either TOEs or functional areas. For example, Table A2 indicates a total of 45 administration buildings which could be consolidated into 12 or fewer by grouping administrative duties according to unit function, rather than assigning an administrative shelter to each unit.

Consolidation of warehouses and maintenance facilities was studied in detail in the Base Development

**Table A2**  
**Shelter Facilities, Phase 5, D+61 to D+90 Days**

|  | Square Feet<br>(Square Meters) |          |
|--|--------------------------------|----------|
| Guardhouse, Wood Bldg. (2)                 | 1,200                          | (110)    |
| Det Hqtr, Wood Bldg. (5)                   | 3,000                          | (280)    |
| Kitchens, Wood Bldg. (10)                  | 3,000                          | (280)    |
| Mess Halls, Wood Bldg. (16)                | 9,600                          | (890)    |
| Dispensary, Wood Bldg. (1)                 | 960                            | (90)     |
| Administration, Wood Bldg. (1)             | 600                            | (55)     |
| Supply, Wood Bldg. (2)                     | 400                            | (40)     |
| Administration, Wood Bldg. (6)             | 5,760                          | (535)    |
| Administration, Wood Bldg. (1)             | 720                            | (65)     |
| Guardhouse, Wood Bldg. (1)                 | 1,500                          | (140)    |
| Check Point, Check Shelter, Wood Bldg. (2) | 1,200                          | (110)    |
| Latrines, Guard Shelter, Wood Bldg. (90)   | 14,400                         | (1 340)  |
| Warehouse, Steel Bldg. (160)               | 614,400*                       | (57 080) |
| Sve Sec Office, Wood Bldg. (2)             | 3,000                          | (280)    |
| Shops, Steel Bldg. (84)                    | 337,680*                       | (31 370) |
| Inspection, Wood Bldg. (1)                 | 720                            | (65)     |
| Offices, Wood Bldg. (14)                   | 13,440                         | (1 250)  |
| Inspection, Wood Bldg. (6)                 | 5,760                          | (535)    |
| Storehouse, Wood Bldg. (3)                 | 2,880                          | (270)    |
| Administration, Wood Bldg. (37)            | 55,500                         | (5 155)  |
| TOTAL                                      | 1,075,720                      | (99 940) |

\*Candidates for shipping container shell facilities.

Study. Of the requirement for construction of 1.1 million sq ft (102 000 m<sup>2</sup>) of shelter during Phase 5, the construction of warehouses and maintenance facilities comprises 89 percent or 0.95 million sq ft (88 500 m<sup>2</sup>). The study team, which considered only AFCS facilities, selected an 80 × 220 ft (24 × 66 m) facility as the standard for both warehouse and maintenance facilities, thus reducing the number of warehouses from 160 to 35 consolidated warehouses. Likewise, maintenance shops were reduced from 84 to 19 consolidated shops.

Consolidating these facilities had a large and favorable impact on the details of the base design, especially on layout of the service road networks and construction of hardstand service areas.

The magnitude of the engineering effort to be expended during Phase 5 is estimated by use of planning factors determined from data supplied in TM 5-303, *AFCS Logistic Data and Bills of Material* (1973). By considering data for facilities in the size range comparable to the standard (80 × 220 ft [24 × 66 m]) adopted by the study team, one obtains 44.2 man-hours/100 sq ft (9 m<sup>2</sup>) of wood-framed building and 28.8 man-hours/100 sq ft (9 m<sup>2</sup>) of steel-framed building as planning factors for use in estimating engineering effort.

Based on the square footage and type of construction indicated in Table A2, the engineering effort required for vertical construction during Phase 5 of the base construction effort is 2.81 battalion months.\* Thus, three construction battalions must be committed to vertical construction from D+61 days to D+90 days to accomplish the construction mission.

## 5 AVAILABILITY OF SHIPPING CONTAINERS

The throughput of each supply class is broken down into three periods: (1) an initial period, (2) a period in which a buildup of supplies takes place, and (3) a final period which extends for the duration of the scenario life. Table A3 provides a summary of the containerized supplies, furnished by the Army Logistic Center for the

\*One battalion month of engineering effort is equivalent to 117,000 man-hours, based on TOE 5-115, Engineering Construction Battalion, with a 6-day workweek, a 12-hour day, and 80 percent availability of the labor force.

buildup and final periods. The buildup period starts at D+26 and lasts for 20 days for all containerized material except Class V (ammunition). The buildup of Class V reserve begins on D+20 and continues through D+115.

In the Base Development Study, the requirements for container storage were obtained from tonnage throughput by assuming that each 20 × 8 × 8 ft (6 × 2.4 × 2.4 m) container was loaded to 10 short tons (9t). It was further assumed that ships will not be permitted to tie up the port while empty containers from the buildup period (excluding ammunition) are collected. Furthermore, it is unlikely that it will ever be considered desirable to send empty ships to the T/O merely to pick up empty containers; hence, an additional backlog of empties will occur just from normal port operations. This backlog was assumed to be 10 days in the Base Development Study.

The total backlog of empty containers, including buildup and operation, amounts to approximately 10,600 containers. Using a storage planning factor of 12 acres/1000 containers (5 hectares/1000 containers), the hardstand requirement for container marshalling is approximately 127 acres (51 hectares), with 60 percent located in the ammunition storage area.

Not all of the empty containers in storage are available for construction purposes. To maintain normal port operations after D+90 days, at which time each ship picks up empties corresponding to the number of containers off-loaded, up to 2000 empties must be held for operations. Thus, only approximately 8600 empty containers are available for construction purposes.

## 6 CANDIDATE FACILITIES FOR BASE II-8

The AFCS facility selected by the Base Development Study team for both the consolidated warehouse and the consolidated maintenance shop was Facility No. 441114, which is a steel-framed building on a 6-in. (152-mm) slab. The dimensions of the facility are 80 × 220 ft (24 × 66 m) with a clear height of 16 ft (5 m). A wood-framed counterpart of this building is Facility No. 441124. Table A4a provides the TM 5-303 listing for both of these facilities.

Table A4b provides comparable data for a shipping container facility. The interior lighting (AFCS No. 441104) and the foundation (AFCS No. 340373) are

**Table A3**  
**Summary of Containerized Working Tonnages**

| Class Supply        | Buildup       |         | 1-Day Throughput |          |
|---------------------|---------------|---------|------------------|----------|
|                     | Tons (Tonnes) |         | Tons (Tonnes)    |          |
| I Subsistence       | 5610          | (5049)  | 280              | (252)    |
| II Clothing         | 5610          | (5049)  | 282              | (253.8)  |
| III POL (Packaged)  | 960           | (864)   | 75               | (67.5)   |
| V Ammunition        | 43500         | (39150) | 3264             | (2937.6) |
| VI Personnel Demand | 3600          | (3240)  | 180              | (162)    |
| VIII Medical        | 600           | (540)   | 20               | (18)     |
| IX Repair Parts     | 3750          | (3375)  | 124              | (111.6)  |
|                     | 63630         | (57267) | 4225             | (3802.5) |

**Table A4**  
**Candidate Facilities for Base II-8**

| Facility Number                                 | Weight,<br>Short<br>Tons<br>(t) | Volume,<br>Measurement<br>Tons<br>(m <sup>3</sup> ) | Cost,<br>\$ | Construction Effort, Man-hours |       |       |       |
|---|---------------------------------|---|-------------|--------------------------------|-------|-------|-------|
|   |                                 |   |             | Horz.                          | Vert. | Gen.  | Tot.  |
| a) AFCS Facilities                              |                                 |   |             |                                |       |       |       |
| 441114 Steel Frame                              | 185<br>(168)                    | 169<br>(193)  | 57,000      | 297                            | 2,903 | 1,864 | 5,064 |
| 441124 Wood Frame                               | 187<br>(170)                    | 210<br>(239)  | 22,000      | 198                            | 5,476 | 2,096 | 7,770 |
| b) Shipping Container Facility (148 containers) |                                 |   |             |                                |       |       |       |
| 441104 Interior                                 | 2<br>(1.8)                      | 2<br>(2.3)  | 908         |                                | 468   |       | 468   |
| 340373 Foundation (18 Units)                    | 88<br>(80)                      | 70<br>(80)  | 4,700       | 53                             | 563   | 1,021 | 1,637 |
| Couplers  | 0.2<br>(0.18)                   | 0.1<br>(0.11)                                       | 6,500       |                                | 333   |       | 333   |
| Sealing   | 0.4<br>(0.36)                   | 0.6<br>(0.68)                                       | 1,500       |                                |       | 282   | 282   |
| Shipping Container                              | 91<br>(83)                      | 73<br>(83)  | 13,600      | 53                             | 1,364 | 1,303 | 2,720 |

identical with that provided for and included in the AFCS facilities given in Table A4a, and are listed here to prevent bias of the trade-off analysis. Man-hours of construction time associated with the coupler include all labor in excess of interior, foundation, and weather-proofing. This construction time is based on 2.25 man-hours per container, including positioning of support containers, coupling to form the box beam, and lifting the box beam into place. There is no charge for used containers, since they will either be part of the inevitable backlog of empties or structurally sound containers not serviceable for logistic purposes.

Table A5 summarizes the cost and construction effort for the 54 warehouse/maintenance shop consolidated facilities for construction Phase 5 (D+61 to D+90 days) of Base II-8. Each facility has approximately 17,000 sq ft (1 580 m<sup>2</sup>) of usable floor space with a 16-ft (5-m) clear height; all have the same foundation and interior lighting.

The Base Development Study group had determined that it was more effective for this specified scenario to select the steel-framed facility over the wood-framed facility; i.e., it was more important to save 1.25 battalion months of construction effort than to save \$1.9 million.

It can be seen from Table A5 that using the shipping containers saves \$1.09 million over the least labor-intensive AFCS facility and approximately \$0.5 million over

the least expensive AFCS facility. Moreover, the number of containers needed for facilities (7992) is compatible with the available backlog of empties (about 8600). Further savings in construction effort is realized because hardstand for storage is not required. This savings is approximately 0.4 battalion months during Phase 2 (D+4 to D+25 days).

## 7 CONCLUSIONS

This analysis of using shipping container facilities as warehouses and maintenance shops to develop a logistic port and base supports the conclusion that this method will effect significant savings in engineer effort. However, one should not presume that all instances of base development would benefit to the same extent.

The availability of shipping containers for construction purposes is greatly dependent on both the magnitude of the buildup and the average throughput.

The requirement for facilities depends on the duration of the scenario; if the duration of the scenario is at least 6 months, then an "intermediate" standard of construction is permitted, and shipping container facilities are candidates for the vertical construction phase.

The application pursued in this research provided an almost perfect match between facility requirements and container availability; hence, the projected savings of 1.49 battalion months of engineer effort (1.09 battalion months of vertical construction effort and 0.40 battalion months of horizontal construction effort) can be realized.

It is important to note that each application must be subjected to the same analytical detail applied to Base II-8 before a rational prediction of engineer effort savings is possible.

**Table A5**  
**Cost-Effort Data for Candidate Facilities for Base II-8**

|                             | Cost,<br>\$1000 | Construction Effort,<br>Battalion Months |
|-----------------------------|-----------------|--|
| AFCS Steel-Framed Building  | 3,078           | 2.34                                     |
| AFCS Wood-Framed Building   | 1,188           | 3.59                                     |
| Shipping Container Building | 734             | 1.25                                     |

## APPENDIX B: CONSTRUCTION PROCEDURES FOR SHIPPING CONTAINER FACILITY

### 1 INTRODUCTION

Shipping container (MILVAN) structures are additional or substitute facilities in which the major facility requirement in the T/O is an 80- to 100-ft (24- to 30-m) clear span structure.

The basic roof system of a MILVAN structure consists of box beams 8 × 8 ft (2.4 × 2.4 m) in cross section and a multiple of 20 ft (6 m) in length. These box beams are formed by joining MILVANs end to end by special couplers. A box beam made up of four MILVANs would be approximately 80 ft (24 m) long.

The box beams are placed at the desired clear height on a support system (which can also consist of MILVANs) with a minimal gap so that the box beams form the total roof system. Since the box beams are 8 ft (2.4 m) wide, a roof system consisting of twelve 80-ft (24-m) box beams would be necessary for a facility with an approximate minimum clear span of 80 ft (24 m) and a maximum clear span or length of approximately 100 ft (30 m). The preferred clear span is 80 ft (24 m), since this span length can accommodate design roof loads at any location in the world. For facilities having short lifetimes or facilities located in tropical or semitropical areas, a 100-ft (30-m) clear span would be acceptable. The clear height would depend on the configuration of the support system. Natural clear heights are 8, 16, 20, and 24 ft (2.4, 5, 6, and 7 m).

The box beams are field-constructed at ground level and lifted into place as a complete unit. A 100-ft (30-m) box beam (constructed of five MILVANs) weighs approximately 15 tons (14 t) and is well within the lift capacity of the 20-ton (18-t) rough terrain mobile crane. Site preparation for box beam construction is minimal since working space is required only at the junctions of the MILVANs; a working area 16 × 8 ft (5 × 2.4 m) is ample at each junction.

The following sections describe overall site preparation necessary for an 80-ft (24-m) clear span facility and a 100-ft (30-m) clear span facility; the various box beam support systems required to attain a family of clear height structures range from 8-ft (2.4-m) to ap-

proximately 30-ft (9-m) clear height. The components of the couplers are identified and their functions described; the step-by-step assembly procedure for coupling MILVANs is presented, along with the lifting procedure for the completed box beam; a list of required material and equipment is provided.

### 2 SITE PREPARATION AND SUPPORT SYSTEMS

The amount of site preparation depends on the size of the facility to be constructed. Figures B1a and B1b represent cross sections of the prepared sites for 80-ft (24-m) box beams (80-ft [24-m] clear span) and 100-ft (30-m) box beams (100-ft [30-m] clear spans). The length of the prepared area is governed by the number of box beams used in the roof system; a foundation length of approximately 8.3 ft (2.59 m) per box beam is an appropriate allowance for the length of the facility.

For the basic shipping container facility with an 80-ft (24-m) clear span consisting of 12 box beams for the roof system, the foundation consists of two pads, each 100 ft (30 m) long, with the cross-section shown in Figure B1a. The interior dimensions of the basic structure are 79 ft, 3 in. × 99 ft (24 × 30 m) yielding a clear area of 7850 sq ft (729 m<sup>2</sup>).

Laying out the support pads requires the same care as laying out any structural foundation, i.e., surveying of four parallel lines of grade stakes at the four pad edges, then moving and compacting soil to this grade level. The compacted soil should have a compressive strength of about 1 kip/sq ft (48 kN/m<sup>2</sup>) or such that a low-tire-pressure vehicle (7 to 10 lb/in. [125 to 179 kg/m]) does not leave persistent tread marks.

Figures B2a and B2b depict a typical support system constructed from MILVANs standing on end that provides a 20-ft (6-m) clear height facility for nominal clear spans of 80 and 100 ft (24 and 30 m). It is important to note that the underside of the MILVAN is positioned to face into the facility; in this position, the structurally strong underside of the MILVAN carries the structural load from the box beam roof system into the foundation.

The accuracy of the internal spacing shown in Figures B2a and B2b should be held to within 1/4 in. (6 mm) (use a steel surveyor's tape) to provide approxi-

mately 6-in (152-mm) bearing between the box beam and the supporting MILVAN at each of its ends. The vertical position of the MILVANs can be set by using standard carpenter shims; measurement of the vertical with a 4-ft (1.2-m) bubble level is sufficiently accurate to maintain the required bearing area.

Horizontal spacing of the support MILVANs is achieved by using a wooden safety spacer (Figure B3) constructed of a 1-ft (0.3-m) length of 2 × 4 in. (51 × 102 mm) (actual 1 1/2 × 3 1/3 in. [38 × 85 mm]) nailed to plywood plate approximately 1-ft (0.3-m) square. The plywood plate can be any convenient thickness of 1/4 in. (6 mm) or more, but should be the same thickness for all plates. Figure B4 depicts the positioning of the three safety spacers used between MILVANs along the box beam support line.

Figure B5a shows a typical box beam support system in which the MILVANs are laid on their sides rather than on end. Again, the underside of the MILVANs faces the interior of the facility to use the strong floor system as the basic vertical structural member. Interior spacing is as shown in Figures B2a and B2b. This type of support system easily permits nominal clear heights

of 8, 16, or 24 ft (2.4, 5, or 8 m), depending on whether MILVANs are stacked one, two, or three high. When stacking MILVANs two or three high, carpenter shims may be required to maintain the vertical alignment necessary to provide adequate bearing at each end of the box beam.

Figure B5b shows an alternate support configuration, in which the door end posts are used as the vertical structural support members. The interior spacing of MILVANs is especially critical; the bearing length cannot exceed 6 in. (152 mm), or there will be a tendency for the top cord of the supporting MILVAN to buckle; this would not degrade the shipping container facility, but it would prevent the MILVAN from being returned to the logistic stream later.

Regardless of whether the support system consists of MILVANs laid on end (for a nominal clear height of 20 ft [6 m]) or of MILVANs laid on side (for nominal clear height of 8, 16, or 24 ft (2.4, 5, or 8 m)), additional clear height can be obtained by excavating below the bottom line of the support system. This additional clear height is obtained at a loss of level floor space within the facility, since a safety setback is required at each support line, as shown in Figure B6.

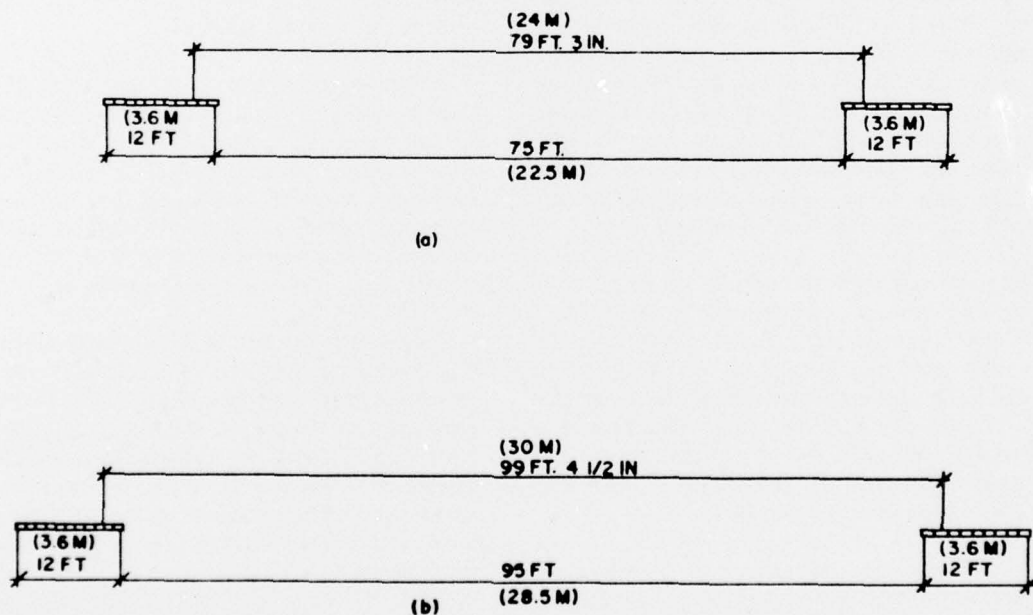
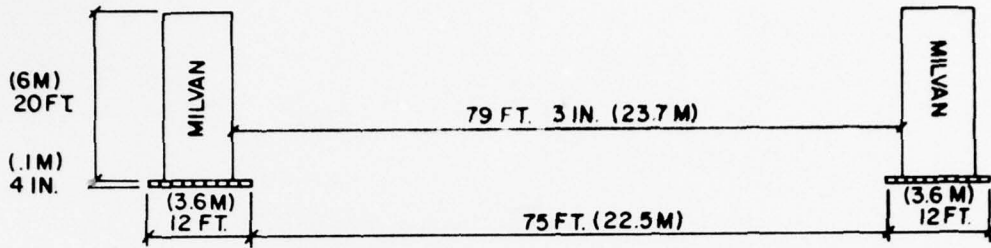
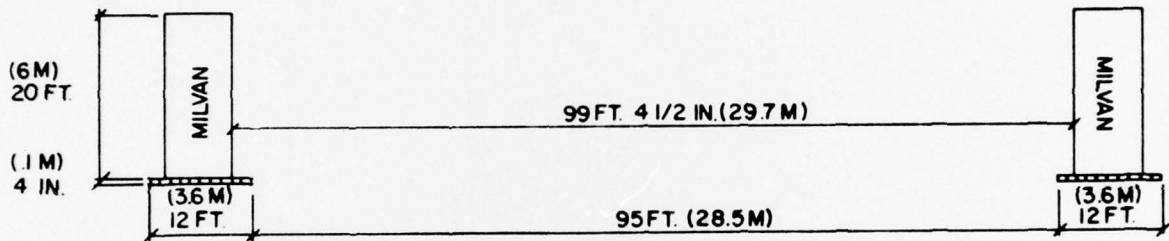

Figure B1. Foundation dimensions.



(a)



(b)

Figure B2. Interior support dimensions—MILVANs on end.

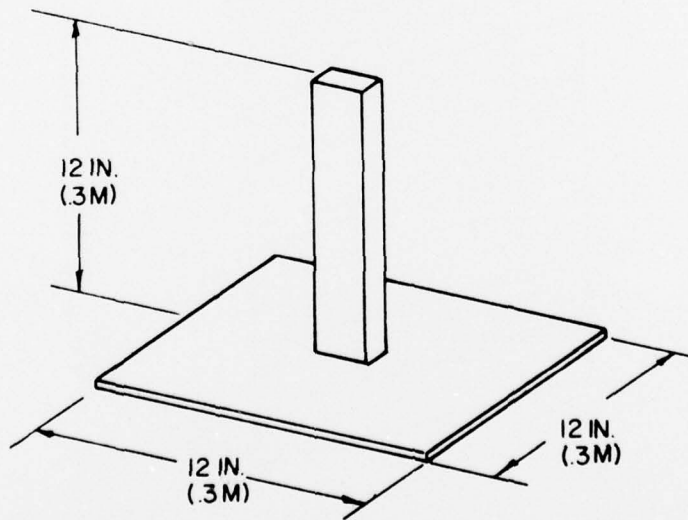

Figure B3. Safety spacer construction.

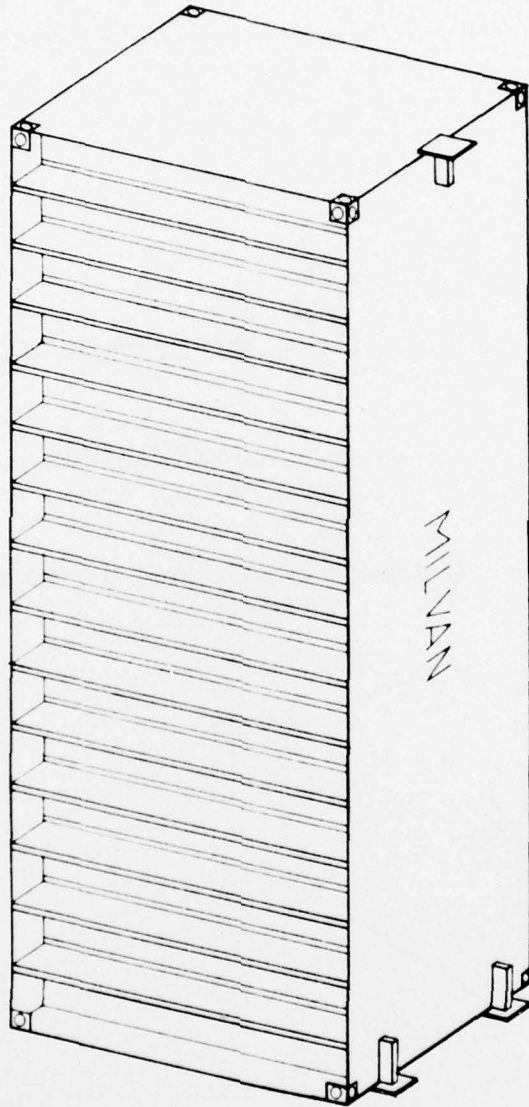

Figure B4. Spacer positioning for support construction.

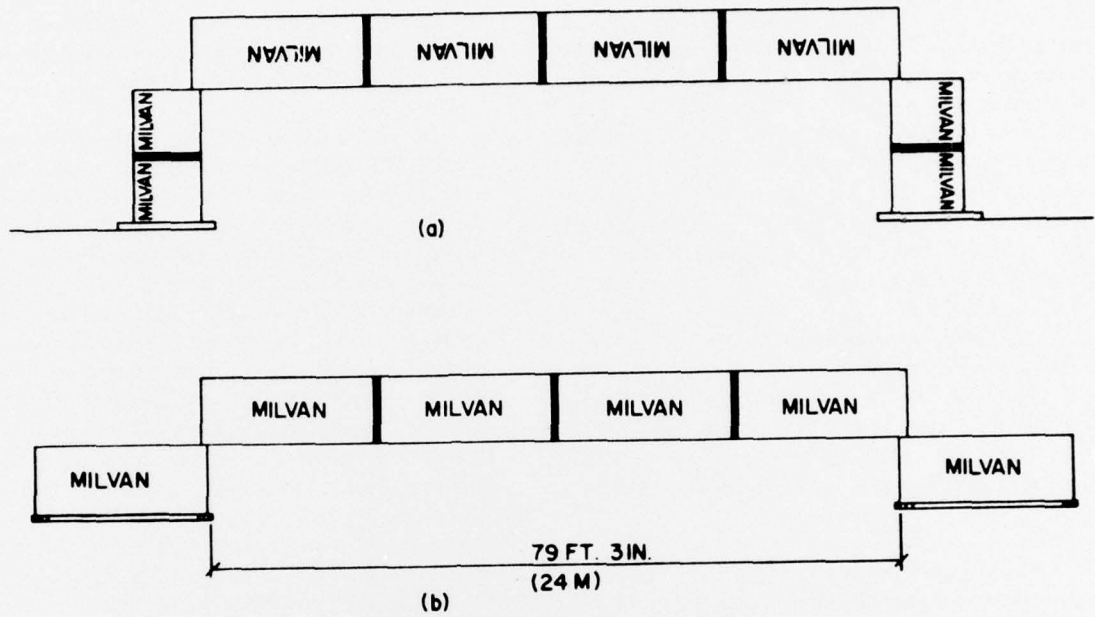

Figure B5. Alternate support system.

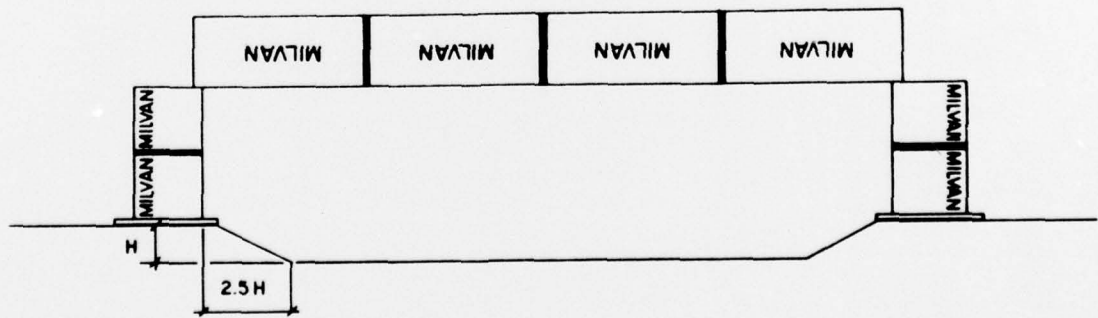

Figure B6. Increased clear height, excavation with safety setback.

### 3 COUPLER DESIGN AND ASSEMBLY

To construct the box beam, MILVANS must be connected end to end. Figure B7 depicts a MILVAN and illustrates the corner fittings available for making this connection. There are four different types of corners, depending on whether the corner is a left- or right-hand corner or an upper or lower corner. For an end to end coupling of MILVANS, the difference between the upper and lower corner fittings requires that the coupling have sufficient flexibility to accommodate hole variations  $1/2$  in. (13 mm) wide.

Figure B8 is an exploded view of the coupler used during the CERL field tests. It is one of several designs that evolved for end to end coupling of MILVANS and was selected for use during the research phase of shipping container structures because of its additional flexibility in meeting possible alignment problems in the field.

The two clips shown in Figure B8 are the load-carrying components; the present geometry and material selection yield a design load for the coupler of 40,000

lb (18 000 kg). The shims are used to accommodate minor variations in hole size of the corner fittings. The stationary double wedge and the two movable wedges provide the mechanism that locks the coupler in place. The movable wedges are made in two sizes to accommodate the major difference in hole size between the upper and lower corners of the fittings.

Figure B9 shows an in-place view of the assembled coupler. The two corner fittings are from adjoining MILVANS. The coupler is assembled by first inserting the clips to span the nominal 3-in. (76-mm) gap between positioned MILVANS. (The usual coating of rust and scale makes this a light press fit.) At this point, an appropriate number of shims and stationary double wedge can be inserted between the clips and hand-held in position until the movable wedges are inserted through the corner fitting into the ends of the now-assembled coupler. The final step of locking the coupler into place is insertion of a pry bar through each side hole of the corner fittings and firmly pushing or hammering the movable wedges into place. All wedges should be checked for tightness when all four corners are connected, since some loosening may occur when the MILVAN is positioned for placement of the last coupler.

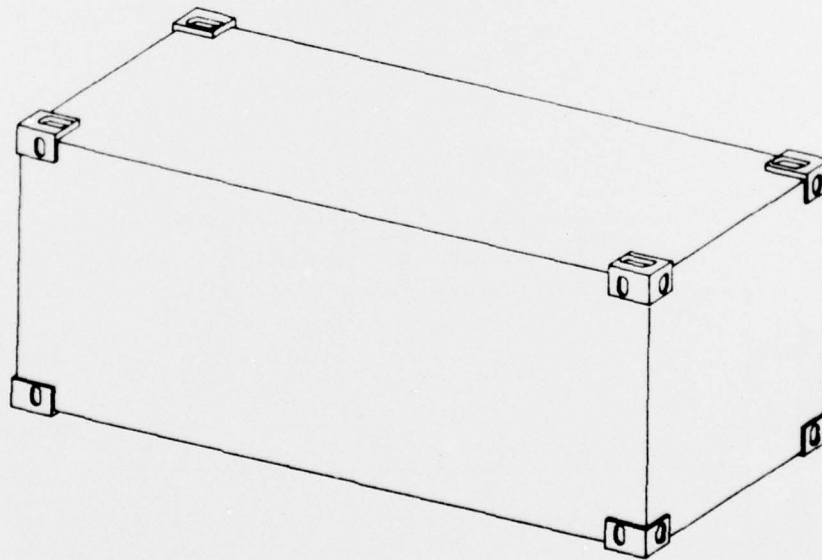

Figure B7. MILVAN dimensions with corner fitting configuration.

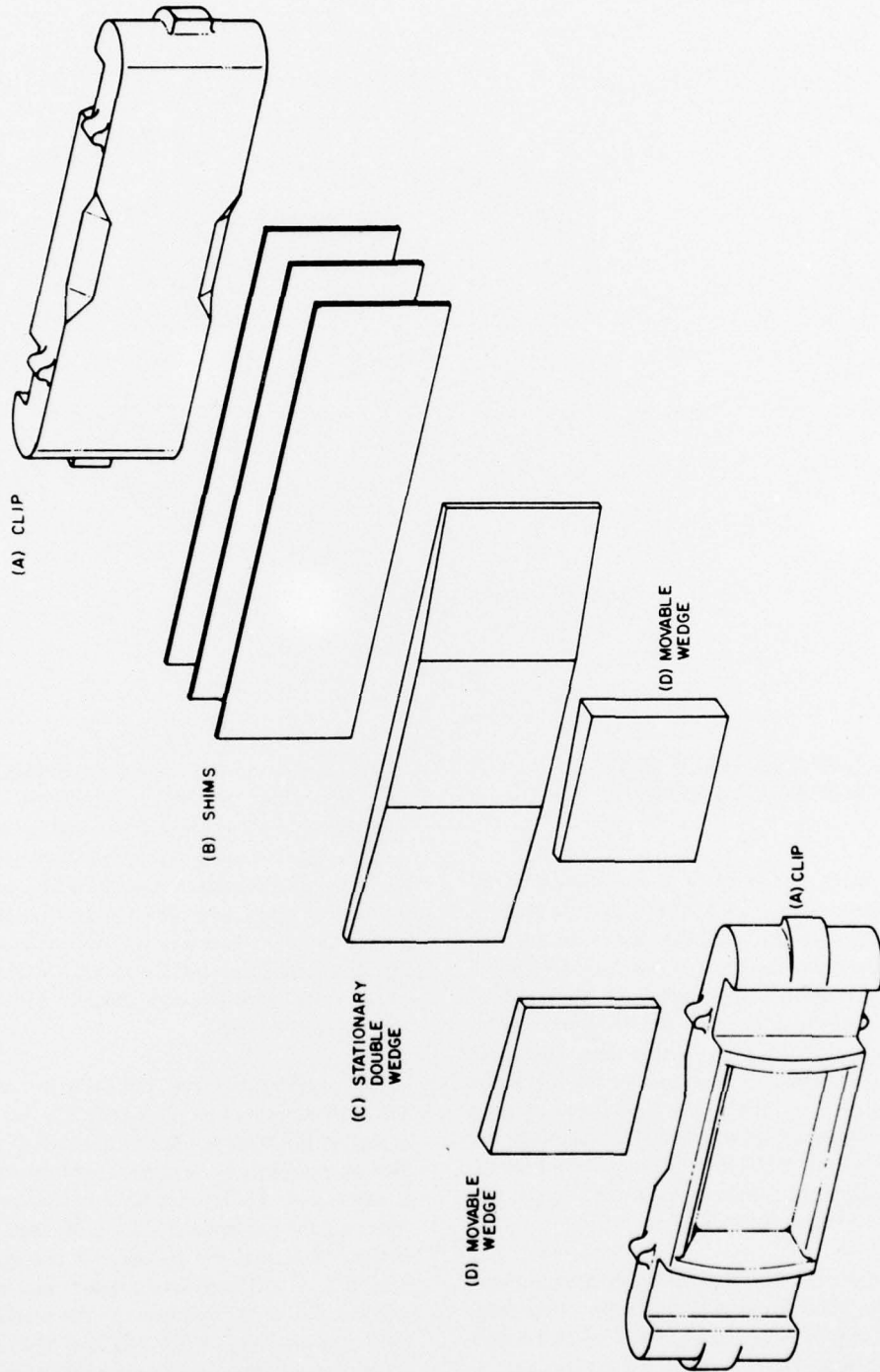

Figure B8. Exploded view of MILVAN coupler.

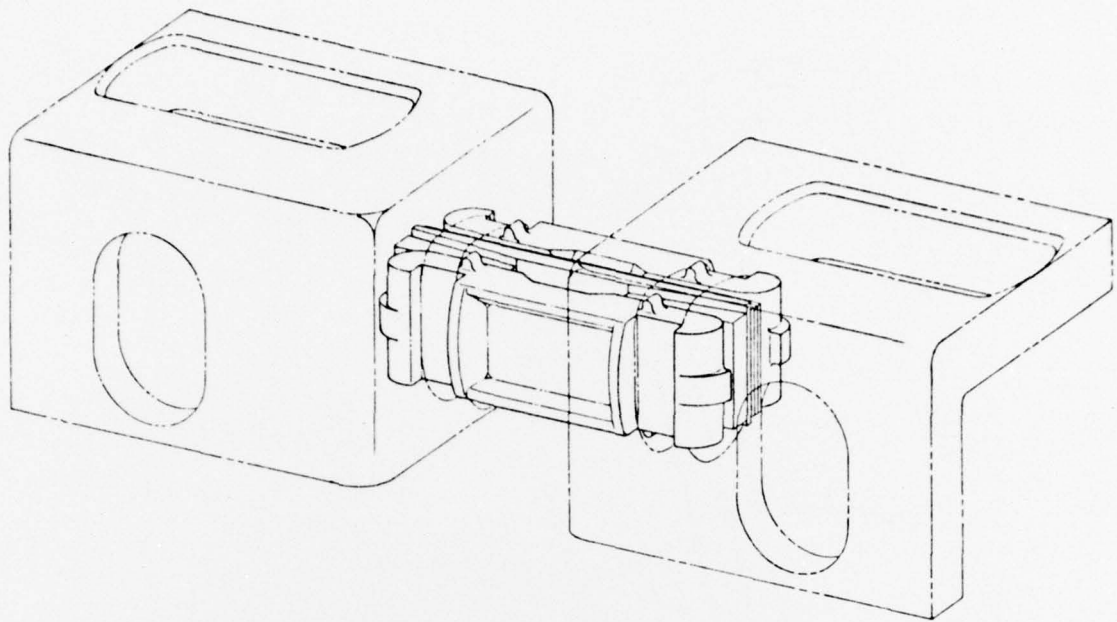

Figure B9. In-place view of assembled coupler.

#### 4 BOX BEAM ASSEMBLY AND PLACEMENT PROCEDURE

The box beam roof member is constructed of inverted MILVANS. The MILVANS are inverted because the upper surface of the box beam is the compressive side of the beam, and the floor of the MILVAN has the compressive strength. For example, an 80-ft (24-m) box beam requires four inverted MILVANS to be positioned in the box beam construction site. Alignment problems are minimized if like ends of the MILVANS are coupled; thus, at this rough positioning stage, a door end of one MILVAN should be connected to the door end of the next MILVAN; likewise, the forward end of one MILVAN should be connected to the forward end of the adjacent MILVAN.

Site preparation for the box beam construction area should receive the same attention as foundation preparation; i.e., a survey of the four (16 × 8 ft [5 × 2.4 m]) working areas approximately 20 ft (6 m) on centers, followed by leveling and compacting of these working areas to a bearing capacity of approximately 1 kip/sq ft (48 kN/m<sup>2</sup>).

Figure B10 shows an inverted MILVAN positioned on two working pedestals, each located in a working area; Figure B11 shows the working pedestal in detail. It is important that the short members of the working pedestal, when supporting a MILVAN, be completely inboard of the corner fittings, since assembly of the coupler requires access to all the corner fitting holes. The short members of the working pedestal provide for vertical alignment between adjacent MILVANS during the assembly process.

Constructing the box beams begins with a single MILVAN supported on work pedestals (see Figure B10). A second MILVAN is lifted by a crane (of at least 5-ton [4.5 t] capacity) by its upper corner fittings where the hoisting chain hooks are placed in the fitting holes exterior to the mating MILVAN ends; then it is roughly positioned so that the mating ends rest against the 2 × 4 in. (51 × 102 mm) safety spacer blocks and lightly rest on the short members of the working pedestal. Since the door end of the MILVAN is heavier than its forward end, it may be necessary for one or two workers to stand on the high end of the crane-supported MILVAN to bring it into the horizontal position. These personnel, by shifting positions, can also adjust the

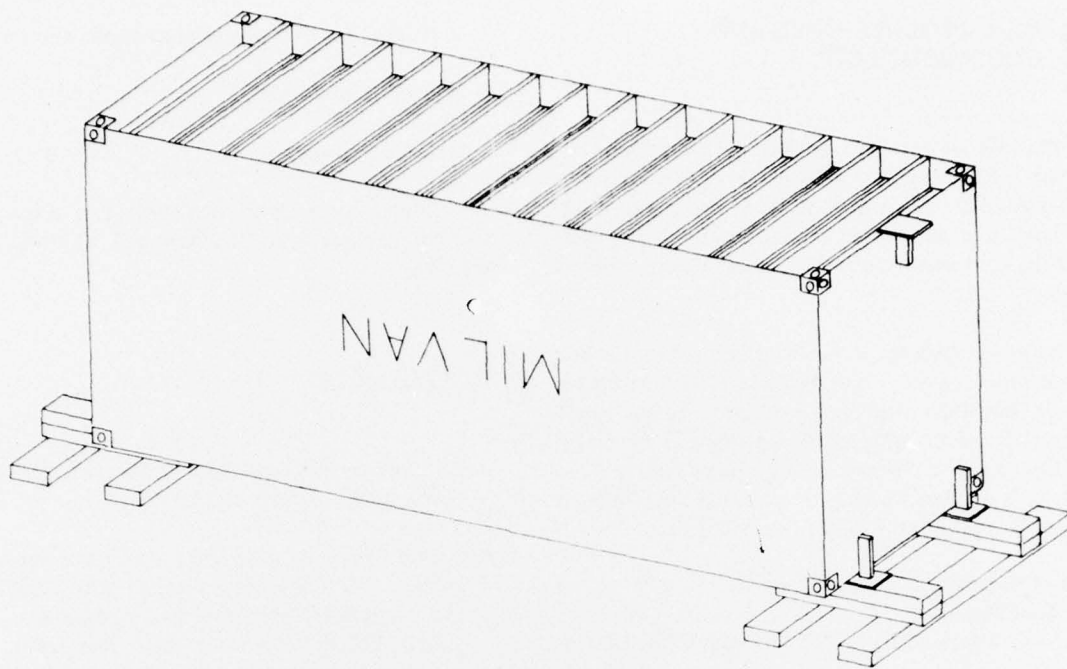

Figure B10. Initial MILVAN positioning for box beam construction.

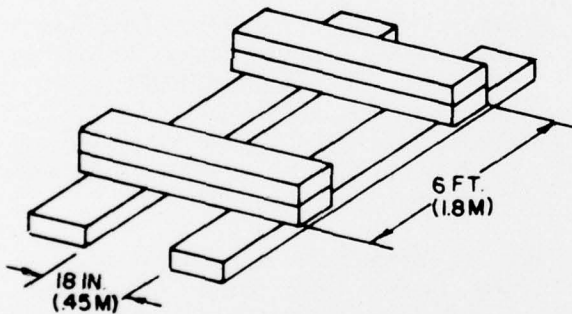

Figure B11. Detail of work positioning pedestal.

pressure of the crane-supported MILVAN on the alignment members of the work pedestal. Final positioning of the mating ends of the MILVANs is accomplished by pry-bars.

The couplers are placed in the lower corner fitting by the procedure described previously; both clips are set in the mating holes, and the shim and stationary double wedge are held in place while the movable wedges are inserted and locked into place with a pry-bar. After the bottom two couplers have been placed,

the upper couplers are inserted and locked; during this step the lift of the crane can help in establishing the necessary tolerances.

After these first two MILVANs are coupled, one supported by work pedestals and the other cantilevered, the crane lifts the cantilevered end, freeing a work pedestal which is then moved along the box beam and reset so that the work pedestals now support the two coupled MILVANs at the end points. The end configuration shown in Figure B10 for one MILVAN now is relocated at the center point of the 80-ft (24-m) box beam.

The third and then the fourth MILVANs are lifted by the crane, and the process described above is repeated.

The completed 80-ft (24-m) box beam is lifted from the center point of the beam with safety lines (two at each end) attached to the *upper* corner fittings at each end. By manipulating the safety lines and gradually lowering the box beam, placement on the beam supports is completed.

The entire procedure is repeated for each box beam required for the facility.

## 5 BILL OF MATERIALS AND EQUIPMENT LIST

The bill of materials (BOM) and equipment list shown below assume that only one crew is employed in constructing box beams. If more than one crew will be used, it is appropriate to multiply both the BOM and the equipment list by the actual number of crews used.

Items not included in the BOM are used for the box beam support system. For example, safety spacers between MILVANs used in the support system would have to be added to the BOM, depending on the length of the facility. Furthermore, if a timber grillage foundation is required because of poor soil conditions, it would be added to the BOM presented here.

### Bill of Materials

#### Wood Planks

4 - 4 in. X 12 in. X 10 ft (102 mm X 0.3 m X 3 m)

8 - 4 in. X 12 in. X 4 ft (102 mm X 0.3 m X 1.2 m)

#### Miscellaneous

8 - 2 in. X 4 in. X 1 ft wood (51 mm X 102 mm X 0.3 m)

8 - 1/4 in. X 1 ft X 1 ft plywood (6 mm X 0.3 m X 0.3 m)

1 - bundle carpenter shims

### Equipment List

1 - 20-ton (18-t) rough terrain crane

2 - hoisting chains consisting of a central ring attached to two 11-ft (3.3-m) lengths of 10-ton (9-t) breaking strength chain and terminating in matching hooks

2 - 5-ft (1.5-m) pry-bars

2 - 2-ft (0.6-m) pry-bars

2 - 3-lb (1.4-kg) sledge hammers

4 - 50-ft (15-m) 1/2-in. (13-mm) manila safety ropes

2 - 12-ft (3.6-m) ladders

2 - grading shovels

Additionally, each 80-ft (24-m) box beam constructed requires four MILVANs and 12 coupler assemblies.

## REFERENCES

*AFCS Logistic Data and Bills of Material*, TM 5-303 (Department of the Army, 1973).

*Base Development Study*; Vol I: *Executive Summary*, ACN 21807; Vol II: *Base Design*, ACN 21807; Vol IV: *Electrical Generation and Distribution*, ACN 20380; Vol V: *Centralized Water Production, Distribution and Disposal*, ACN 20381; Vol VI: *Vertical Construction*, ACN 20383; Vol VIII: *Base Maintenance Study*, ACN 20518 (TRADOC, 1976).

*Computer Assisted System for Theater Level Engineering (CASTLE)* (Engineers Strategy Study Group, Office of the Chief of Engineers, 1972).

Container, Cargo, Drawings, Code Identification No. 97403-13219 E00000 through E0020 (U. S. Army Mobility Equipment Command, 1970).

Holze, G. *Stiffness Matrix Reduction for Large Structural Systems Using Cholesky Decomposition*, Interim Report S-24/AD#768721 (U. S. Army Construction Engineering Research Laboratory, October 1973).

*Ownership and Use of Containers for Surface Transportation and Configuration of Shelters/Special-Purpose Vans*, DOD Instruction 4500.37 (Department of Defense, 1973).

Rosen, R. and M. Rubinstein, "Substructure Analysis by Matrix Decomposition," *Journal of the Structural Division A. S. C. E.*, Vol 96, No. ST3 (March 1970), pp 663-670.

## CERL DISTRIBUTION

US Army, Europe  
ATTN: AEEN (2)  
  
Director of Facilities Engineering  
APO NY 09827  
APO Seattle, WA 98749

West Point, NY 10996  
ATTN: Dept of Mechanics  
ATTN: Library

HQDA (SGRD-EDE)

Chief of Engineers  
ATTN: Tech Monitor  
ATTN: DAEN-ASI-L (2)  
ATTN: DAEN-FE  
ATTN: DAEN-FEE-A  
ATTN: DAEN-FEM  
ATTN: DAEN-FEP  
ATTN: DAEN-FEE-P  
ATTN: DAEN-FEZ-A  
ATTN: DAEN-MCZ-S (2)  
ATTN: DAEN-RDL  
ATTN: DAEN-ZCP  
ATTN: DAEN-PMS (12)  
for forwarding to  
National Defense Headquarters  
Director General of Construction  
Ottawa, Ontario K1A0K2  
Canada

Canadian Forces Liaison Officer (4)  
US Army Mobility Equipment  
Research and Development Command  
Ft Belvoir, VA 22060

Div of Bldg Research  
National Research Council  
Montreal Road  
Ottawa, Ontario, K1A0R6

British Liaison Officer (5)  
US Army Mobility Equipment  
Research and Development Center  
Ft Belvoir, VA 22060

Airports and Const. Services Dir.  
Technical Information Reference  
Centre  
KAOL, Transport Canada Building  
Place de Ville, Ottawa, Ontario  
Canada, K1A0N8

Ft Belvoir, VA 22060  
ATTN: Learning Resources Center  
ATTN: ATSE-TD-TL (2)  
ATTN: Kingman Bldg, Library

US Army Foreign Science & Tech Center  
ATTN: Charlottesville, VA 22901  
ATTN: Far East Office

Ft Monroe, VA 23651  
ATTN: ATEN  
ATTN: ATEN-FE  
ATTN: ATEN-RAG  
ATTN: ATEN-RM

Ft Lee, VA 23801  
ATTN: DRVMC-D (2)

Ft McPherson, GA 30330  
ATTN: AFEN-FEB

USA-WES  
ATTN: Concrete Laboratory  
ATTN: Soils and Pavement Laboratory  
ATTN: Library

USA-CRREL

6th US Army  
ATTN: AFKC-LG-E

I Corps (POK/US) Group  
APO San Francisco 96358

US Army Engineer District  
New York  
ATTN: Chief, WAJEN-M  
ATTN: Chief, Design Br.

US Army Engineer District

Buffalo  
ATTN: Library  
Pittsburgh  
ATTN: Library  
Philadelphia  
ATTN: Library  
ATTN: Chief, NAPEN-D  
Baltimore  
ATTN: Library  
Norfolk  
ATTN: Library  
ATTN: Chief, NAOEN-M

Huntington  
ATTN: Library  
ATTN: Chief, ORHED  
Wilmington  
ATTN: Chief, SAWEN-D  
Savannah  
ATTN: Library  
ATTN: Chief, SASAS-L  
Mobile  
ATTN: Library  
ATTN: Chief, SAMEN

Louisville  
ATTN: Chief, Engr Div  
Detroit  
ATTN: Library  
ATTN: Chief, NCEED-T

St. Paul  
ATTN: Chief, ED-E  
Rock Island  
ATTN: Library  
ATTN: Chief, Engr Div  
ATTN: Chief, NCRE-D

St. Louis  
ATTN: Library  
ATTN: Chief, ED-D  
Kansas City  
ATTN: Library (2)  
ATTN: Chief, Engr Div

Omaha  
ATTN: Chief, Engr Div  
New Orleans  
ATTN: Chief, LMNED-DG  
ATTN: Library

Little Rock  
ATTN: Chief, Engr Div  
Tulsa  
ATTN: Library

Fort Worth  
ATTN: Library  
ATTN: Chief, SWFED-D  
ATTN: Chief, SWFED-F

Albuquerque  
ATTN: Library  
Los Angeles  
ATTN: Library

San Francisco  
ATTN: Chief, Engr Div  
Sacramento  
ATTN: Library, Room 8307  
ATTN: Chief, SPKED-D

Far East  
ATTN: Chief, Engr Div  
Japan  
ATTN: Library

Walla Walla  
ATTN: Chief, Engr Div  
Alaska  
ATTN: Library  
ATTN: NPADE-R

US Army Engineer Division  
Europe  
ATTN: Technical Library  
New England  
ATTN: Library  
ATTN: Chief, NEDED-T

North Atlantic  
ATTN: Chief, NADEN-T  
Middle East (Rear)  
ATTN: MEDED-T  
South Atlantic  
ATTN: Library

ATTN: Chief, SADEN-TS  
ATTN: Library  
Huntsville  
ATTN: Library (2)  
ATTN: Chief, HNDED-CS  
ATTN: Chief, HNDED-M  
ATTN: Chief, HNDED-ME

US Army Engineer Division  
Lower Mississippi Valley  
ATTN: Library

Ohio River  
ATTN: Laboratory  
ATTN: Chief, Engr Div  
ATTN: Library

North Central  
ATTN: Library  
ATTN: Chief, Engr Div  
Missouri River  
ATTN: Library (2)  
ATTN: Chief, MRDED-M

Southwestern  
ATTN: Library  
ATTN: Chief, SEDED-MA  
Pacific Ocean  
ATTN: Chief, Engr Div  
ATTN: FMMS Branch  
ATTN: Chief, PODED-M

North Pacific  
ATTN: Chief, Engr Div  
  
Facilities Engineer  
Carlisle Barracks, PA 17013  
Ft Hood, TX 76544  
Ft Campbell, KY 42223

FORSCOM  
Ft Devens, MA 01433  
Ft George G. Meade, MD 20755  
Ft McPherson, GA 30330  
Ft Sam Houston, TX 78234  
Ft Carson, CO 80913  
Ft Lewis, WA 98433 (2)

USAECCOM  
Ft Monmouth, NJ 07703  
DSCPER  
West Point, NY 10996

USATCFE  
Ft Eustis, VA 23604  
USATC (3)  
Ft Benning, GA 31905

USAAVNC  
Ft Rucker, AL 36361  
CACAFEL (3)  
Ft Leavenworth, KS 66027

AMC  
Dugway, UT 84022  
USACC  
Ft Huachuca, AZ 85613

TRADOC  
Ft Dix, NJ 08640  
Ft Belvoir, VA 22060  
Ft Monroe, VA 23651  
Ft Lee, VA 23601  
Ft Gordon, GA 30905  
Ft McClellan, AL 36201  
Ft Knox, KY 40121  
Ft Benjamin Harrison, IN 46216  
Ft Leonard Wood, MO 65473  
Ft Chaffee, AR 72905  
Ft Sill, OK 73503  
Ft Bliss, TX 79916

HQ, 1st Inf Div & Ft Riley, KS 66442  
HQ, 5th Inf Div & Ft Polk, LA 71459  
HQ, 7th Inf Div & Ft Ord, CA 93941  
HQ, 24th Inf Div & Ft Stewart, GA 31313

AF/RDXT  
WASH DC 20330  
  
AF Civil Engr Center/XRL  
Tyndall AFB, FL 32401

Little Rock AFB  
ATTN: 314/DEEE (Mr. Gillham)

NAVFAC/Code 04  
Alexandria, VA 22332

Port Hueneke, CA 93043  
ATTN: Library (Code LOBA)  
ATTN: Morrell Library

Washington, DC  
ATTN: Building Research Advisory Board  
ATTN: Transportation Research Board  
ATTN: Library of Congress (2)  
ATTN: Dept of Transportation Library

Defense Documentation Center (12)

Engineering Societies Library  
New York, NY 10017

US Army/FESA  
Bldg 358  
Ft Belvoir, VA 22060