

AD-A042 329

ILC INDUSTRIES INC FREDERICA DEL
DEVELOPMENT OF A FIRE PROTECTIVE OVERGARMENT FOR USE BY AIR CAR--ETC(U)
FEB 77 J F RAYFIELD

F/G 6/17

DOT-FA75WA-3696

UNCLASSIFIED

FAA-RD-77-18

NL

1 OF 2
ADA042329



REPORT No FAA-RD-77-18

J *(12)*

ADA 042329

DEVELOPMENT OF A FIRE PROTECTIVE OVERGARMENT FOR USE BY AIR CARRIER FLIGHT ATTENDANTS

John F. Rayfield
ILC INDUSTRIES, INC.
Frederica, Delaware



FEBRUARY 1977

FINAL REPORT

DDC
AUG 2 1977
C

Document is available to the U.S. public through
the National Technical Information Service,
Springfield, Virginia 22161.

Prepared for

U.S. DEPARTMENT OF TRANSPORTATION
FEDERAL AVIATION ADMINISTRATION
Systems Research & Development Service
Washington, D.C. 20590

UJ NO. _____
DDC FILE COPY
ORIGINAL CONTAINS COLOR PLATES: ALL DDC
REPRODUCTIONS WILL BE IN BLACK AND WHITE.

NOTICE

The United States Government does not endorse products or manufacturers. Trade or manufacturers' names appear herein solely because they are considered essential to the object of this report.

This Document is disseminated under the sponsorship of the Department of Transportation in the interest of information exchange. The United States Government assumes no liability for its contents or use thereof.

Technical Report Documentation Page

1. Report No. 19 FAA-RD-77-18 ✓	2. Government Accession No.	3. Recipient's Catalog No.	
4. Title and Subtitle 6 DEVELOPMENT OF A FIRE PROTECTIVE OVERGARMENT FOR USE BY AIR CARRIER FLIGHT ATTENDANTS.		5. Report Date 11 February 1977	6. Performing Organization Code
7. Author(s) 10 John F. Rayfield	8. Performing Organization Report No. FAA-RD-77-18		10. Work Unit No. (TRAIS)
9. Performing Organization Name and Address ILC Industries, Inc. P.O. Box 266 Frederica, DE 19946 SIC 403776		11. Contract or Grant No. 15 DOT-FA75WA-3696 (new)	13. Type of Report and Period Covered 9 FINAL + rept July '75 - Feb. '77
12. Sponsoring Agency Name and Address U. S. Department of Transportation Federal Aviation Administration Systems Research & Development Service Washington, D.C. 20591		14. Sponsoring Agency Code ARD 520	
15. Supplementary Notes 13 94p.			
16. Abstract The objective of this effort was to develop a garment to provide protection to flight attendants in proximity to cabin fires. Based on laboratory flame and heat flux tests, garment materials were chosen. A prototype garment was fabricated, including a breathing system and hood. The garment was tested for donning and mobility in an aircraft cabin, and was subjected to a simulated cabin fire exposure that approximated the contract design conditions.			
17. Key Words Aircraft, Fabrics, Fire, Flame-Resistant Materials, Flight Attendants, Protective Garments, Heat Flux, Breathing System		18. Distribution Statement Document is available to U. S. public through the National Technical Information Service, Springfield, VA 22161.	
19. Security Classif. (of this report) UNCLASSIFIED	20. Security Classif. (of this page) UNCLASSIFIED	21. No. of Pages 99	22. Price

403776

JP

METRIC CONVERSION FACTORS

Approximate Conversions to Metric Measures			Approximate Conversions from Metric Measures					
Symbol	When You Know	Multiply by	To Find	Symbol	When You Know	Multiply by	To Find	Symbol
LENGTH								
in	inches	2.5	centimeters	cm	millimeters	0.04	inches	in
ft	feet	30	centimeters	cm	centimeters	0.4	inches	in
yd	yards	0.9	meters	m	meters	3.3	feet	ft
mi	miles	1.6	kilometers	km	kilometers	0.6	miles	mi
AREA								
in ²	square inches	6.5	square centimeters	cm ²	square centimeters	0.16	square inches	in ²
ft ²	square feet	0.09	square meters	m ²	square meters	1.2	square yards	yd ²
yd ²	square yards	0.8	square meters	m ²	square kilometers	0.4	square miles	mi ²
mi ²	square miles	2.6	square kilometers	km ²	hectares (10,000 m ²)	2.5	acres	ac
MASS (weight)								
oz	ounces	28	grams	g	grams	0.035	ounces	oz
lb	pounds	0.45	kilograms	kg	kilograms	2.2	pounds	lb
	short tons (2000 lb)	0.9	tonnes	t	tonnes (1000 kg)	1.1	short tons	st
VOLUME								
tsp	teaspoons	5	milliliters	ml	milliliters	0.03	fluid ounces	fl oz
Tbsp	tablespoons	15	milliliters	ml	liters	2.1	pints	pt
fl oz	fluid ounces	30	milliliters	ml	liters	1.06	quarts	qt
c	cups	0.24	liters	l	liters	0.26	gallons	gal
pt	pints	0.47	liters	l	cubic meters	35	cubic feet	ft ³
qt	quarts	0.95	liters	l	cubic meters	1.3	cubic yards	yd ³
gal	gallons	3.8	liters	l				
ft ³	cubic feet	0.03	cubic meters	m ³				
yd ³	cubic yards	0.76	cubic meters	m ³				
TEMPERATURE (exact)								
°F	Fahrenheit temperature	5/9 (after subtracting 32)	Celsius temperature	°C	Celsius temperature	9/5 (then add 32)	Fahrenheit temperature	°F

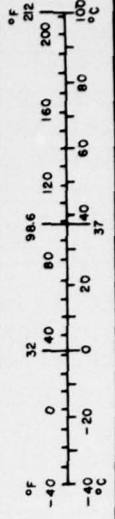
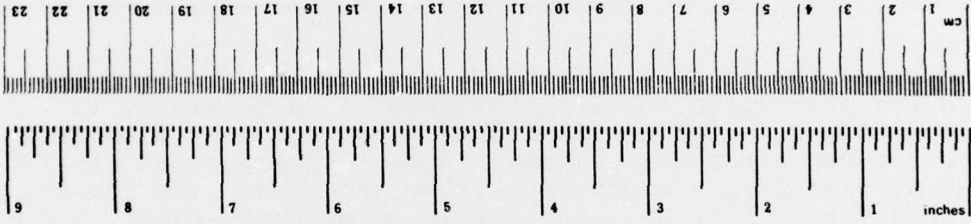

*1 in. = 2.54 (exactly). For other exact conversions and more detailed tables, see NBS Misc. Publ. 286, Units of Weights and Measures, Price \$2.25, SD Catalog No. C13.10.286.

TABLE OF CONTENTS

	<u>Page</u>
1.0 INTRODUCTION	1
2.0 REQUIREMENTS FOR PROTECTIVE OVERGARMENT.	1
3.0 MATERIALS EVALUATION AND SELECTION	2
3.1 OVERGARMENT CROSS SECTION.	3
3.2 CANDIDATE MATERIALS.	4
3.3 LABORATORY MATERIAL TESTS.	5
4.0 GARMENT CONFIGURATION.	8
5.0 BREATHING SYSTEM	12
5.1 HOOD	12
5.2 AIR SUPPLY SYSTEM.	18
6.0 PROTOTYPE FABRICATION AND INTEGRATION.	27
7.0 FULL-SCALE DEMONSTRATIONS.	29
7.1 DONNING AND MOBILITY	29
7.2 SIMULATED CABIN FIRE	31
8.0 CONCLUSIONS.	32
9.0 REFERENCES	34

APPENDIX A - BREATHING SYSTEM SPECIFICATION,
BENDIX TEST DATA, RECHARGE INSTRUCTIONS

APPENDIX B - EVALUATION OF THERMAL PROTECTION IN
FULL SCALE EXPOSURE OF A PROTOTYPE
FLIGHT ATTENDANTS' FIRE PROTECTIVE
OVERGARMENT

ACCESSION for	
HTIS	Write Section <input checked="" type="checkbox"/>
BSC	Butt Section <input type="checkbox"/>
UNANNOUNCED	<input type="checkbox"/>
JUSTIFICATION	
BY	
DISTRIBUTION/AVAILABILITY CODES	
DTG	AVAIL. and/or SPECIAL
A	

LIST OF FIGURES

<u>Figure</u>	<u>Title</u>	<u>Page</u>
1	Protective Overgarment Candidate Materials Matrix	6
2	Donning Sequence for Reversible Cape Mockup.	10
3	Prototype Garment.	13
4	Breathing System	14
5	Air Supply System Layout	19
6	Air Supply System Operation.	20
7	Calibration of Subject's Metabolic Rate. . .	21
8	Air Supply System Manned Test.	22
9	Air Supply System Manned Test Results. . . .	23
10	Air Supply System Manned Test Results. . . .	24
11	Modified and Unmodified Breathing Hoses for Noise Reduction.	26
12	Garment Preparation for Stowage.	30

LIST OF TABLES

<u>Table</u>	<u>Title</u>	<u>Page</u>
I	Fabric Samples Tested for FAA Flight Attendants Overgarment	7a
II	Hood Materials Tested for FAA Flight Attendants Overgarment	7c
III	Data Obtained by Naval Air Development Center @ 0.7 CAL/SQ.CM/SEC. Incident Radiation - Quartz Lamp.	7d

1.0

INTRODUCTION

This report documents the effort performed under FAA Contract DOT-FA75WA-3696 for the design, development, test and evaluation of a Prototype Fire Protective Overgarment for use by air carrier flight attendants in post-crash cabin fire environments that would be untenable to an unprotected person.

The program included laboratory test and evaluation of candidate garment materials, garment design, breathing system design and development, and full-scale cabin usage and fire exposure demonstrations.

The Breathing System Specifications and Development Tests performed by the Bendix Company are described in Appendix A. The Fire Exposure Garment Tests and Skin-Burn Analysis were conducted by the Naval Air Development Center and are described in Appendix B. Both tasks were conducted under contracts to ILC Industries or FAA.

2.0

REQUIREMENTS FOR PROTECTIVE OVERGARMENT

Initially, the overgarment was conceived as one which could be worn by a flight attendant during takeoff and landing without it being conspicuous or identifiable as fire protective clothing. A head cover and portable breathing air supply were to be integrated into the garment so as to be ready for rapid donning and actuation when needed. Maintenance servicing, cost and weight requirements were considered. Other detailed design requirements were as follows:

- a. Garment design concept shall be adaptable for use by both male and female flight attendants.
- b. The garment design shall allow adaptation to the styling of various air carriers.
- c. The garment shall be donnable in ten (10) seconds or less; the head cover and breathing system shall be usable in five (5) seconds or less.
- d. The breathing system shall provide an air supply of not less than eight (8) minutes duration.
- e. The garment shall be capable of being folded and stowed in a minimum volume.

- f. The garment shall withstand exposure to time/history thermal/smoke profile equivalent to a cabin location about 7 feet from the fire source.

<u>Time</u>	<u>Head Level Temp. °F</u>	<u>Knee Level Temp. °F</u>	<u>Smoke Density</u>	<u>Heat Flux BTU/Sq.Ft./Sec.</u>
0	100	70	0	0
60 sec.	375	200	65-80%	0.10
2 to 5 min.	650 to 1250	200-300	100%	0.4 to 1.9

- g. The garment shall limit the wearer's skin temperature rise to 16°F when exposed to the thermal profile in "f" above (i.e., no surface contacting the skin should exceed 111°F).
- h. Materials used in the garment shall be commercially available.
- i. The garment assembly and materials shall be qualified by laboratory thermal testing, a full-scale simulated cabin fire test, cleaning tests, demonstration of the operation of the head cover and breathing apparatus, and full-scale cabin mobility and functional demonstrations.

The thermal environment specified in (f) was based primarily upon thermal flux and temperature data obtained in the NASA-JSC cabin fire tests performed in a Boeing 737 fuselage (Ref. 1).

3.0

MATERIALS EVALUATION AND SELECTION

In order for a material to be considered a candidate for use in the overgarment it was required to be, as a minimum:

- Resistant to flame impingement (while not an explicit contractual requirement, felt to be mandatory in this application).
- Self-extinguishing in air.
- Commercially available at reasonable cost.
- Easily fabricated (e.g., marked, cut, sewn, taped) into garment components.
- Durable in fabrication, handling, folding, stowage, laundering and use.
- Reasonable in cost.

3.1 OVERGARMENT CROSS SECTION

It was apparent that no single material possessed all of the properties desirable in a thermal barrier. A multi-layered cross section was therefore proposed to make most efficient use of the various available materials.

3.1.1 Requirements Analysis - Thermal

Since the overgarment is primarily a thermal barrier, the requirements of the overgarment materials were developed in terms of the mechanisms by which heat transfer occurs:

- a. Radiation - Heat could pass through the overgarment by direct radiation and by radiation from the back surface of the materials. It was therefore desirable to incorporate a reflective barrier in the form of metallized film or fabric. For maximum effect the barrier had to be at or near the surface of the garment.
- b. Conduction - Heat could pass through the overgarment by direct contact of the materials with each other. The quantity of heat transferred is a function of the inherent conductivity of the materials. Since air is less conductive than any materials of fabrication, it was desirable that fibrous materials of low density and contact area be incorporated. Most constructions of this type (e.g., felts and battings) are more flammable, offer no barrier to radiation, and must be used in conjunction with radiation and fire-penetration resistant materials.

The high conductivity of metal components such as snaps, zippers, grommets or other hardware items required that they be either covered or backed by sufficient insulation to insure they were not the source of heat leaks or burns.

- c. Convection - The transfer of heat by air movement normally is associated with the rise of relatively lighter hot air. It was important that the garment restrict free air movement to prevent hot air from flowing through the garment to inner layers and exposed skin.

3.1.2 Materials Characteristics Analysis

3.1.2.1 Radiation Barrier

To be an effective radiation barrier a material must reflect well in the wave length range of the heat source and reflect poorly, i.e., have high emittance, at wave lengths representative of its surface temperature.

While an important consideration in dealing with high temperature sources such as the sun (5800°K), there is virtually no change in spectral properties of most materials in the narrow range of 294°K to 1200°K (70°F to 1700°F), i.e., from room temperature to the approximate anticipated (black body source) fire temperature. Most fabrics are poor reflectors throughout this range with dark colors being slightly better than light colors. They are also low in transmittance of radiant energy. Most of the incident energy is, therefore, absorbed and re-radiated.

Since fabrics are poor reflectors of radiant energy, the overgarment cross section had to include at least one material or surface, other than fabric, which was an effective reflector. Polished metal surfaces are effective radiation reflectors and are used extensively in the form of thin coatings applied to fabric and film surfaces. Ideally, the incident energy should be reflected at the exterior surface. Since this was not feasible for a garment which must be color coordinated and textured to satisfy routine cabin service, it was proposed to keep this layer concealed under decorative, lightweight fabrics.

The decorative fabric would reach extremely high temperatures in the specified thermal environment. Under these conditions it could not burn or give off large quantities of smoke or lethal gases. Embrittlement, charring or flaking off would be acceptable if these did not degrade the garment performance. The decorative covering, in other words, could be expendable provided its degradation would not interfere with the function of the other layers.

3.1.2.2 Conductive and Convective Barrier

The inside surface of the reflective barrier was expected to heat up to a temperature well in excess of the maximum permissible skin contact temperature of 111°F, so it had to be kept from contact with the inner layer of the overgarment and the attendant's clothing and skin. Since controlled separation with low conduction is best achieved in flexible cross sections by low density scrims or non-woven felts or battings, it was proposed to incorporate such a material as an inner layer in the overgarment.

3.2 CANDIDATE MATERIALS

A great deal of data has been generated on materials performance and physical properties on exposure to extreme environments. While this data was of great help in initial screening of materials for the overgarment, it did not clearly define the optimum combination for this particular application. Most of the data was related to direct, short-term exposure (three seconds to one minute) to fuel fires of extreme intensity. The long-term exposure to

the lower thermal levels required in this program dictated that testing to those conditions be performed.

A list of candidate materials for each layer of the proposed overgarment was compiled from published data and industry contacts. This list, together with the desired attributes of each layer, is shown in Figure 1.

3.3 LABORATORY MATERIAL TESTS

A series of laboratory tests was run on many of these materials, both separately and in lay-ups. Results of these tests are shown in Tables I, II and III. The tests for Tables I and II were run at ILC Industries' facility at Frederica, Delaware; the tests for Table III were run at the Naval Air Development Center, Warminster, Pennsylvania.

3.3.1 NADC Laboratory Tests

The method used for measuring the heat transmitted through candidate visor and protective garment materials was essentially that used routinely in the NADC laboratory for assessing the protective capacity of aviator's textile materials (reference 5, 846-850). Briefly, it consists of exposing the material to radiation from a bank of quartz lamps set at a voltage appropriate to provide the desired thermal flux, and then measuring the radiation incident on the specimen and the heat transmitted through the specimen during the total exposure time. The results are expressed as a ratio of the transmitted energy over the incident energy to yield percent of heat transferred.

In the present instance, the desired flux was $0.7 \text{ cal/cm}^2 \text{ sec}$ ($2.6 \text{ BTU/Ft}^2 \text{ Sec} = 1.9 \text{ BTU/Ft}^2 \text{ Sec} \times 1.5 \text{ Safety Factor}$) and the exposure time, 5 minutes. The color temperature of the source at this level of emission was 1850°K , peaking at about 1.5μ wave length. The voltage necessary to provide the desired flux was established by preliminary operations and measurements of source output. Then the source was set at the correct voltage and the specimen placed against the exposure aperture. Two shutters were used to prevent pre-heating of the specimen during warm-up of the source.

The procedure for a determination of heat transfer, then, was to turn on the power to the source, permit it to reach a steady output at the voltage selected, expose the specimen for five minutes while measuring calorimetrically and continuously the energy transferred through the specimen, terminating the exposure at the end of the fixed exposure time, and comparing energy transferred to energy incident.

Figure 1

PROTECTIVE OVERGARMENT

CANDIDATE MATERIALS MATRIX

<u>EXTERIOR LAYER</u>	<u>REFLECTIVE LAYER</u>	<u>INSULATION LAYER (IF REQUIRED)</u>	<u>LINER LAYER</u>	<u>HEADCOVER/VISOR</u>
NOMEX KYNOL DURETTE TREATED COTTON TREATED WOOL BETA CLOTH TEFLON FIREPREL NOMEX III KEVLAR NASA POLYIMIDE	ASTROLON ASTROLAR SUPERFLOC ALUMINIZED MYLAR ALUMINIZED KAPTON ALUMINIZED NYLON ALUMINIZED TYVEK	NOMEX SCRIM NOMEX FELT KYNOL FELT KYNOL SCRIM NOTE: THIS LAYER COULD BE COMBINED WITH THE REFLECTIVE LAYER AND/OR THE LINER LAYER.	NOMEX NOMEX III NYLON DACRON COTTON TEFLON FIREPREL BLENDS TBD DURETTE	METALLIZED MYLAR METALLIZED KAPTON METALLIZED FEP TEFLON METALLIZED POLYCARBONATE METALLIZED POLYSULFONE METALLIZED GLASS
<u>EXTERIOR LAYER REQUIREMENTS</u>	<u>REFLECTIVE LAYER REQUIREMENTS</u>	<u>INSULATION LAYER REQUIREMENTS</u>	<u>LINER LAYER REQUIREMENTS</u>	<u>HEADCOVER/VISOR REQUIREMENTS</u>
<ul style="list-style-type: none"> • FIRE RESISTANT • AESTHETICALLY PLEASING • MODERATE COST • EASE OF FABRICATION • AVAILABLE • LAUNDERABLE • ACCEPTABLE WEIGHT 	<ul style="list-style-type: none"> • FIRE RESISTANT • INEXPENSIVE • EASE OF FABRICATION • COMPATIBLE WITH CLEANING TECHNIQUE • LIGHTWEIGHT • GOOD PLIABILITY • ADEQUATE STRENGTH • READILY AVAILABLE 	<ul style="list-style-type: none"> • FIRE RESISTANT • PLIABLE • COMPATIBLE WITH CLEANING TECHNIQUE • MODERATE COST • ADEQUATE STRENGTH • LIGHTWEIGHT • AVAILABLE • EASY TO FABRICATE • DURABLE 	<ul style="list-style-type: none"> • EASY TO DON • EASY TO FABRICATE • LAUNDERABLE • LIGHTWEIGHT • MAXIMUM FIRE RESISTANCE WITH OTHER REQUIREMENTS • INEXPENSIVE 	<ul style="list-style-type: none"> • GOOD OPTICS • SCRATCH RESISTANT • MINIMUM HEAT TRANSFER • AVAILABILITY • EASY TO STOW • EASY TO FABRICATE • FLEXIBLE • MODERATE COST • STRUCTURALLY SOUND

Because of concern over possible ignition of hair or wig materials within the hood, an additional procedure was instituted. This consisted simply of exposing samples of human hair to the prescribed pulse by attaching it to the back of the visor material (gold-coated Mylar) under consideration. In addition, because of concern over possible skin contact with the visor material, a normal subject placed his hand in contact with the back of the visor material during a standard 5-minute exposure, without discomfort or injury.

The results obtained with six specimens are shown in Table III. It is seen that the gold-coated Mylar (Sample 1) transferred only 9.4% of the incident energy, an amount insufficient to cause pain or damage to skin even when in contact with the material in the 5-minute exposure. Needless to say, the hair was also unaffected. Samples 2A and 2B illustrate the advantage of aluminizing the outside surface of protective garment material; almost 30% more of the incident energy is obstructed from passage by the reflectivity of the surface. The silvery lamé was too light in weight and discontinuous in reflecting surface to be adequately reflective, permitting 28% of the incident energy to be transferred. Sample #4 was the most effective and #5 was acceptable.

ILC Laboratory Tests

There was some question as to the advisability of using a quartz lamp floodlight for the ILC radiant laboratory tests. It was pointed out that the quartz lamp, with a color temperature of 3200°K, has a different spectral emittance profile (energy versus wave length) than do fuel or cabin materials fires (1200°K). The lamp manufacturer (Sylvania) stated that at 3200°K the lamp radiates essentially as a black body and that 80 percent of the energy is in the near-infrared range and 15 percent in the visible range. The effect of higher color temperatures is to shift more energy toward the lower wave lengths, so there was concern that the materials might not react to the quartz lamp exposure as they would react to a radiating fire. The lamp color temperature could, of course, be lowered by reducing the lamp voltage. Unfortunately, this also reduces the heat output. In this case, lowering the current to two (2) amperes lowered the color temperature to about 1200°K, but it also lowered the heat flux at 4-1/2 inches from the lamp to less than 1.0 BTU/Ft²/Sec. Thus, without a special apparatus with an array of several lamps, providing design heat flux and proper color temperature was not possible. Since a quick and economical method was required to screen candidate materials and lay-ups, it was not feasible to use the test apparatus at NADC for initial screening. It was finally concluded that the

FABRIC SAMPLES TESTED FOR FAA FLIGHT ATTENDANTS OVERGARMENT

TABLE I

<u>Material</u>	<u>Chemical Family</u>	<u>Description</u>	<u>Thermal Response Max. 5-Min. Exposure to Quartz Lamp (a)</u>	<u>Flame (b) Impingement</u>	<u>Possible Application</u>	<u>Remarks</u>
Treated Cotton	Cellulose	Blue Cloth	Poor - Charred at 30-sec. exposure.	Poor - Burns freely.	Comfort Liner	Not suitable for exposure to flame or high flux radiant heat.
Kynol	Phenolic	Light Brown Cloth	Fair - Charred at 3-1/2-min. exposure.	Good - Chars but does not burn thru.		
Durette	Modified Aromatic Polyamide	Light Brown Batting	Fair(-) - Charred at 2-3/4-min. exposure.	Poor - Burns thru & smolders.	Insulation Layer	Good insulator if not exposed directly to flame or high flux radiant heat.
Durette	"	Light Brown Knitted	Fair(-) - Charred at 2-1/2 min.	Poor - Burns thru rapidly.		Backing of layup charred at 4 min.
Durette	"	Light Brown Cloth	Good - Slightly scorched after 5-min. exposure.	Good - Self-extinguishing.	Overlay*	*If dyed light color.
Nomex	Aryl Polyamide	White Cloth	Good - Yellow @ 4 min. Some shrinkage.	Good - Shrivels, melts, no drip. Self-extinguishing.	Loose Overlay	Shrinkage undesirable.
Nomex Dyed	"	Red Cloth	Fair(-) - Charred 2 min.	Fair - Melts, no drip, shrinks; self-extinguishing.	Comfort Liner	High heat absorption and shrinkage undesirable.
Nomex III	"	White Cloth	Good - Slightly yellow @ 4-1/2 min. Slight shrinkage.	Good - Less shrivel, no drip, self-extinguishing.	Loose Overlay	Shrinkage undesirable though less than original Nomex.

(a) Specimen 4-1/2" from center of 500 watt Quartz Lamp.

(b) Momentary (1-2 seconds) exposure to propane torch flame.

FABRIC SAMPLES TESTED FOR FAA FLIGHT ATTENDANTS OVERGARMENT

TABLE I (CONTINUED)

<u>Material</u>	<u>Chemical Family</u>	<u>Description</u>	<u>Thermal Response Max. 5-Min. Exposure to Quartz Lamp</u>	<u>Flame Impingement</u>	<u>Possible Application</u>	<u>Remarks</u>
Aluminized Glass	Glass	Silver on white fabric	Excellent	Good - Non-burning.	Outer Layer	Flame removed aluminum but glass retained structural integrity.
Aluminized Nomex	Aryl Polyamide	Silver on light brown fabric	Excellent	Fair - Self- extinguishing.	Outer Layer	Flame removed aluminum. Fabric burned through.
Aluminized Kynol	Phenolic	Silver on light brown fabric.	Excellent	Fair - Self- extinguishing.	Outer Layer	Flame removed aluminum. Fabric burned through.
NASA Polyimide	Polyimide	Bright Yellow Fabric	Very Good. Wrinkled at 3 min. No color change. Protected underlay well.	Insufficient sample to test.	Outer Layer	Material not commer- cially available at present - development sample tested.

HOOD MATERIALS TESTED FOR FAA FLIGHT ATTENDANTS OVERGARMENT

TABLE II

<u>Material</u>	<u>Chemical Family</u>	<u>Description</u>	<u>Thermal Response Max. 5-Min. Exposure to Quartz Lamp (a)</u>	<u>Flame (b) Impingement</u>	<u>Service Temperature °F - Max.</u>	<u>Remarks</u>
Mylar - Gold Coated	Polyester	Highly reflective Gold-colored Film	Excellent. No change at 5 min.	Poor - Burns freely.	400	Best reflective material tested with Quartz lamp.
Aluminized FEP	Polyfluoro Carbon	Reflective Film - Silver Color	Fair - Wrinkled.	Fair - Melts and runs; self-extinguishing.	550	May emit small quantity toxic vapor when burning.
Kapton	Polyimide	Yellow Film	Good. Dimensionally OK, but darkens.	Burns but self-extinguishing.	800 - 1000	Light transmission - low. Limited to 1 mil film. Fragile.
Lightly Aluminized Kapton	Polyimide	Yellow Film	Good. Same as uncoated Kapton.	Slightly better than uncoated Kapton.	800 - 1000	1 mil maximum film thickness usable. Poor light transmission

(a) Specimen 4-1/2" from center of 500 watt Quartz Lamp, mounted in floodlight, full voltage (120) applied.

(b) Momentary (1-2 seconds) exposure to propane torch flame.

DATA OBTAINED BY NAVAL AIR DEVELOPMENT CENTER
@ 0.7 CAL/SQ.CM/SEC. INCIDENT RADIATION - QUARTZ LAMP

TABLE III

Description	Function	Approximate Thickness	% Heat Transfer	Remarks
1. Gold coat Mylar	Hood Visor	5 mil	9.4	1-sec. burn thru; not self-extinguishing (flame impingement test).
2A. Blue Cotton Outer/ Aluminized Glass/ Durette Batting/ Nomex Lining	Cosmetized Garment Layup	1/4"	36.4	Cotton chars; becomes black body heat absorber.
2B. Aluminized Glass/ Durette Batting/ Nomex Lining	Garment Layup	1/4"	7.0	-
3. Silver Lame	Outer Surface		28.2	Low density, open weave, translucent, not satisfactory.
4. Aluminized Durette/ Medium Durette Batting/ FR-treated Cotton (Blue)	Garment Layup	1/8"	5.5	External surface smoother than 2B. Reflects more heat.
5. Aluminized Kynol/ Kynol Needle Batting with Scrim	Garment Layup	1/8"	9.7	-

shift in the spectral distribution at from 1200°K to 3200°K was not sufficient to cause significant differences in the way the materials in question would react and that the heat-flux level was by far the most important factor in whether or not a material passed or failed. This conclusion was supported by the fact that the results obtained with the 3200°K lamp were identical to those obtained with the NADC (1850°K) array for materials tested both ways.

3.3.3 Laundering Tests

Swatches of the garment cross-section were subjected to normal perma-press wash cycles, using consumer detergents. After five washings, the fabrics were holding up well, but a definite dulling of the aluminizing film was noted. This was attributed to the corrosion of the aluminum by the detergents, which are alkaline. After 10 washings, the aluminization was unacceptably dull.

New swatches were prepared and dry cleaned using standard dry cleaning solvents. It was found that the materials showed little degradation at 25 cleanings, and probably would have withstood many more.

4.0 GARMENT CONFIGURATION

It soon became evident from the laboratory tests that the concept of an exterior, cosmetic layer (airline color) which would either maintain its integrity, or at least not degrade the thermal protective qualities of the garment layup, was not possible with non-exotic materials. Several fabrics survived, with minor damage, the maximum flux level of 0.7 CAL/CM²/SEC when in their natural color; however, dyed samples of these same materials shrank, carbonized, fumed, and generally degraded to such an extent that continued exposure to the flux caused heat transfer to, and rapid degradation of, the metallized reflective layers under them. The only materials showing no degradation were Kevlar and a developmental NASA polyimide (these were tested only to provide comparative data; they were not considered viable candidates, due to lack of availability, cost, and/or lack of proven usage).

In addition to the problem of material degradation, the total heat flow into the interior of the garment was considered. With the specified heat-flux/time profile the total radiation would be 350 BTU/Ft². Obviously, the garment would have to prevent a large portion of the flux from passing into the interior, or it would quickly become untenable for the wearer. Therefore, to keep the insulative layer to a minimum thickness (1/8 inch or less), it was necessary to maintain a high reflectance throughout the exposure period. And, since

none of the material candidates for the outer layer could be dyed for cosmetic purposes and still not blacken and then degrade the reflective layer when exposed to the thermal environment, it was concluded that the reflective layer must be outermost upon garment exposure to the heat flux. This could have been achieved in several ways:

- Use of an outer aesthetic layer that could be quickly removed and discarded ("tear-away"), and could be styled to any airlines motif and installed over a standard basic garment.
- Use of a reversible cape configuration. This would be a styled cape containing the gloves, arms, head cover, and breathing system. It would be thrown around the shoulders for take-off and landing and deployed/donned in the event of a cabin fire.
- Use of a quick-donning pullover garment that would be stowed in an appropriate cabin location and donned in the event of a cabin fire. This would eliminate the need for a cosmetic layer.

The tear-away approach was discarded for several reasons. It might be accidentally removed by catching or snagging on protuberances during routine wear; during an emergency, it might be discarded and become an obstacle in the evacuation path; it might not be torn away by an anxious wearer and could then render the garment ineffective and turn it into a hazard for the wearer.

The reversible cape approach showed promise of retaining the original goal of wear during takeoff and landing. In this concept, the liner of the cape would be a reflective layer, so that it would become the outer layer when the cape was reversed and donned. The arm/gloves and head cover would be concealed under the cape; when the cape was reversed, they would be on the outside of the garment. Then the hood would be pulled up and over the head. Once the skirt was pulled down over the legs, the garment would be closed by a Velcro closure down the front. The cosmetic outer layer of the cape would become the liner of the garment when deployed.

A bulk and donning mockup was fabricated to evaluate this concept further. It had integral gloves and arms, an integral pullover hood, and a breathing system pocket on the back over the shoulder blades. Its donning sequence is shown in Figure 2. It was found that, with a little practice, a subject could reverse, don, and deploy the mockup garment in about 10 seconds.



Figure 2 - Donning Sequence
for Reversible Cape Mockup



Figure 2 (cont'd)

The cape concept was ultimately discarded for several reasons. It was recognized that the breathing package represented a potential injury source, when stowed on the back, in the event of a hard landing or crash impact. It also became obvious that the garment cross-section required for thermal protection would be warm and uncomfortable for routine wear.

It was therefore concluded that Configuration C (Figure 3)- a stow-and-don-when-needed configuration was necessary. Its layout is very similar to that of the fully deployed cape-type garment. It is donned by pulling it over the head like a turtleneck sweater. The head cover contains the breathing hood. When the garment is donned, the head is automatically pushed thru a rubber neck-seal and into the hood. The time required to retrieve this garment from stowage, don it, and actuate the breathing system was about 10 seconds.

Based on all requirements and on the materials test and evaluation, the garment cross-section finally chosen was as follows: (See Tables I, II, and III)

- Outer Layer - Garment - Aluminized Kynol Fabric
Gloves - Aluminized Glass Fabric
- Insulation Layer - Kynol Needle Batting with Scrim
(1/8" thick, 4 oz/yd² nominal)
- Liner - Durette Fabric (5 oz/yd² nominal)

Aluminized Kynol was chosen for the outer layer of the garment because of its overall best performance in testing and a lower weight than glass fabric. Aluminized glass was chosen for the gloves to provide extra flame impingement and thermal protection to the hands. Kynol batting was chosen over Durette and Nomex batting due to the propensity of the latter materials to shrink upon exposure to heat and flame. Durette was used for the liner because it is the most slippery of the flame-retardant materials; this was done to maximize the ease of donning and doffing the garment.

5.0 BREATHING SYSTEM (FIGURE 4)

The breathing system consists of the hood, hoses, and air supply system. A detailed specification for the breathing system, and instructions for charging the gas bottle, are contained in Appendix A. A discussion of the system design and test follows below.

5.1 HOOD

The hood is designed to encase the head completely. A thin (.005 in) natural rubber neck-seal is attached to the bottom of the cylindrical hood. The neck seal



Figure 3 - Prototype Garment

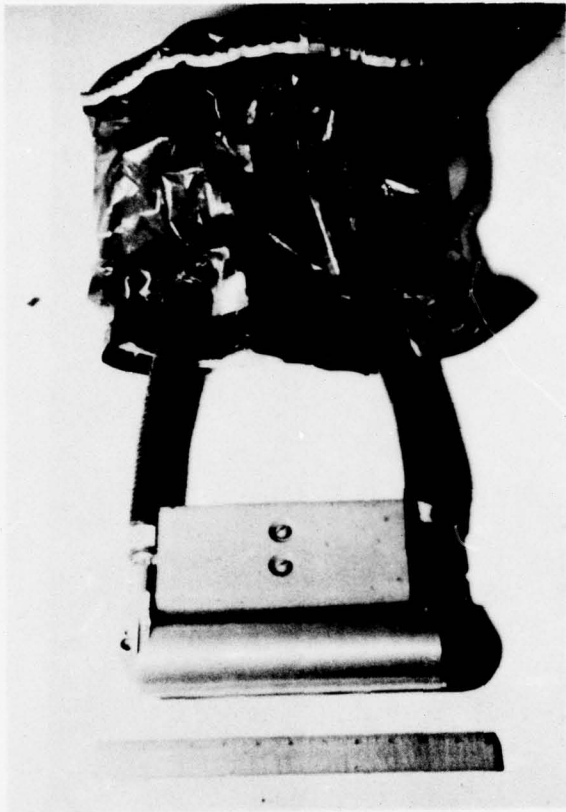

Figure 4 - Breathing System

has a 3.5 inch diameter hole in the center to accommodate the 5th percentile female flight attendant neck circumference, and the rubber is sufficiently elastic to be pulled down over the 95th percentile male head quite readily. When the hood is pulled down over the head, and the seal is in place around the neck, a gas-tight seal is effected. An inlet hose and outlet hose (MS22055H12) are attached to the back of the hood. To limit and preserve the positive pressure inside the hood during breathing system operation, an exhalation valve is mounted in the hood wall. This valve opens to relieve internal pressures of 1 inch of water or more. Pressure relief would be necessary if the air supply regulator malfunctioned and fed air into the system at too high a rate or if the user's O₂ uptake rate was unusually low, or if the system was used at elevated altitudes.

The requirements of the candidate materials for the hood were basically the same as those for the garment materials except that the hood had to be transparent. Ground rules were also established to the effect that the thermal requirements could be subordinated to hearing requirements, and hearing requirements could be subordinated to visibility requirements, should a compromise be necessary. The only materials for the hood that were established to be candidates were Kapton, FEP Teflon film and Mylar. All these materials are flexible, a feature highly desirable from the standpoint of minimum stowage volume. Mylar is not self-extinguishing in air. However, with a gold coating, it is an excellent thermal radiation barrier, but still allows good transmission of visible light. Kapton, while it has good thermal and flame properties, also has a deep straw color, and its thickness must be limited to about 1 mil to minimize the attenuation of visible light. In addition, any metallizing of the Kapton surface is undesirable because visible light transmission is reduced by such coating. This, in combination with the light attenuation of the Kapton itself, renders unacceptable the visibility in low illumination conditions, such as could be encountered in a cabin fire emergency.

(Some notes about metal coatings: In subjectively comparing goldized and aluminized clear substrates, it was obvious that the gold was the more desirable one, in that it admitted more light in the higher wave lengths where the eye is more sensitive. Both coatings had about the same total reflectance in the near infrared range (about 95%), and about 20% visible light transmission. Aluminum coatings are much more durable than gold coatings when subjected to handling, abrasion, or creasing.)

FEP Teflon film is highly flexible, transparent, and self-extinguishing in air. With a gold coating, it would be an excellent choice for the hood material, except for the widespread misgivings about toxic products of fluoropolymers in a fire situation. Extensive conversation with DuPont Company personnel and perusal of reports on the toxic products of burning or pyrolyzing fluoropolymers established the facts in this regard. First of all, one must distinguish between the products of combustion and of pyrolysis. If FEP is burned freely in air, by flame impingement for example, the only toxic product expected would be HF, but only if considerable moisture were present in the surrounding air to supply the H₂. To get some idea of the potential concentration of HF, consider that saturated air at STP contains about 0.012 lb H₂O/Ft³ or 0.00075 lb H₂/Ft³. If all H₂ present forms HF, then burning FEP yields $0.00075 \times 20 \frac{\text{lb HF}}{\text{lb H}_2}$, or 0.015 lb HF/Ft³ air. HF is rated as "dangerous, even for brief exposures" at concentrations of 50 to 250 PPM (Ref. 3, p. 823). 250 PPM translates to:

$$.08 \text{ lb Air} \times 250 \text{ PPM} \times 10^{-6} = 0.000002 \frac{\text{lb HF}}{\text{Ft}^3 \text{ Air}}$$

or about one thousandth of the concentration possible with a reasonable amount of air dilutant.

To take this one step further, the pyrolysis of FEP, chemically (C₂F₄)_n, in air could follow the (worst case) relation:

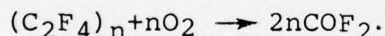

COF₂, carbonyl fluoride, is the agent... "implicated as the primary cause of the pulmonary edema resulting from (rat) exposure to the 550°C pyrosolate produced from"... pyrolysis of fluoropolymers (Ref. 4).

If all available F₂ were converted into COF₂, then 0.32 lb O₂ would be required per 1.0 lb FEP. Or, at STP, 16.8 ft³ of air would be required for each 1.0 lb of FEP to be pyrolyzed to COF₂. The (exposed) visual field of the hood, if .005 inches thick, would weigh about 0.016 lbs. About 0.27 ft³ of air must be available to pyrolyze this amount of FEP into 0.02 lbs of COF₂. Assuming this product was put into any reasonable volume of surrounding air, the concentration would be far above the "dangerous" level for short-term exposure (50-250 PPM, Ref. 3, p. 536).

Both HF and COF₂ are classified as powerful irritants, with much the same effects on the pulmonary tract when inhaled (Ref. 3); i.e., both will produce severe toxicity on an "acute local" basis when inhaled for a few seconds or minutes.

This toxicity analysis was used in evaluating FEP as a hood material. Pyrolysis of the visual, uncovered part of the hood is unlikely to occur during the scenario constructed for the use of the overgarment system. But if it did occur due to unusual circumstances (e.g. disabled wearer in close proximity to a fire), the result could be severe injury, or fatality. Combustion of the visual field area could conceivably occur during egress through or around a fire. If large amounts of water vapor were in the air, as may be the case in the proximity of an organic material fire, then dangerous concentrations of HF could easily be formed. In both cases, the toxic agent would be produced in or near the oro-nasal area.

It could be argued that these eventualities are far-fetched and might be overlooked in light of the impressive advantages of FEP film: clear, durable, flexible, heat-sealable, self-extinguishing up to 46% O₂, absence of smoke during combustion, and good optical quality. However, it was concluded that in the absence of thermal tests of actual hood assemblies and determination of resulting levels of toxic products in the oro-nasal area, use of the FEP film could not be justified. (Such tests were outside the scope of this program).

The choice was now between Kapton and Mylar for the hood material. Combustion of either material produces only minor quantities of toxic substances, in no way comparable to those produced by FEP. Pyrolysis of Kapton produces mostly CO₂ and H₂O, with minor quantities of CO, N₂, and no HCN or benzene measurable. Pyrolysis of Mylar produces acetaldehyde in sufficient concentrations to be a local irritant and lacrimator. In addition, Mylar burns freely in air.

Since it was strongly felt that no material should be used in the overgarment that was not self-extinguishing and was also exposed to the outer environment, Mylar was rejected in favor of Kapton.

At this point, a compromise was required. It was certain that a goldized Kapton would reject sufficient incident heat flux to meet the design conditions specified in the contract. However, it was equally certain that goldizing the Kapton would make its visible light transmission unacceptably low. Based on the ground rules, therefore, the thermal requirement was subordinated to the requirement for maximum visibility. It was decided to use an uncoated 1 mil Kapton hood. It was felt that, in most situations, the wearer could turn away from a fire, or otherwise protect the facial area, if the incident flux approached the discomfort level.

5.2

AIR SUPPLY SYSTEM

The air (40% O₂) supply system was designed and fabricated by the Instruments and Life Support Division of Bendix Corporation, Davenport, Iowa. It includes the air supply cylinder, carbon dioxide canister, pressure reducer, venturi-aspirator assembly, fill and release mechanism, flow manifold, and pressure gage. The mode of operation and general layout of the system is shown in Figures 5 and 6. Basically, the system is a closed loop rebreather. When the high pressure (3000 PSI) air cylinder is actuated by pulling the "red ball", the gas is passed thru a pressure reducer, which drops the pressure to 23-25 PSI. The gas then passes thru an orifice in the throat of the venturi-aspirator assembly, drawing along entrained gas and passing it thru the inlet hose and into the hood. In the hood, the fresh gas mingles with the exhaled gases and the mixture is inhaled. At the same time, some of the mixture passes through the exhaust hose and into the CO₂ canister. As it passes thru the CO₂ absorbent (in this case, "Soda-Sorb" was used), the mixture loses most of its CO₂ and water vapor. It also picks up heat from the absorption process, so it is then passed over the air cylinder (which chills as it loses pressure) before it passes back into the venturi-aspirator. Because the hood is flexible and has a large volume relative to breathing tidal-volume, the hood maintains its shape, and a slight positive pressure prevails inside the hood at all times. The system was tested by Bendix with human subjects walking at 3.5 MPH on a treadmill at an angle of 15°. (See Figures 7 and 8.) Representative results of these tests are shown in Figures 9 and 10. The tests demonstrated that the system meets the requirements of the contract, as reflected in the breathing system specification (see Appendix A), except that it will not provide an acceptable level of O₂ at 15,000 feet for the entire use period.

One undesirable characteristic of this breathing system - or any similar system employing a venturi-aspirator device to circulate the breathing gas - is the noise generated by the orifice flow in the throat of the venturi. In this particular system, the noise due to the injection jet was measured at 83 db, inside the hood. Since this level of sound could interfere significantly with the wearer's verbal communication, it was decided to investigate ways of attenuating it. This type of noise is of relatively high frequency (~2,000 H_z) and is easily transmitted thru a conduit like the breathing hoses. Fortunately, noise of this frequency is also easily attenuated. It was found that the use of baffle materials or structures in the

BEST AVAILABLE COPY

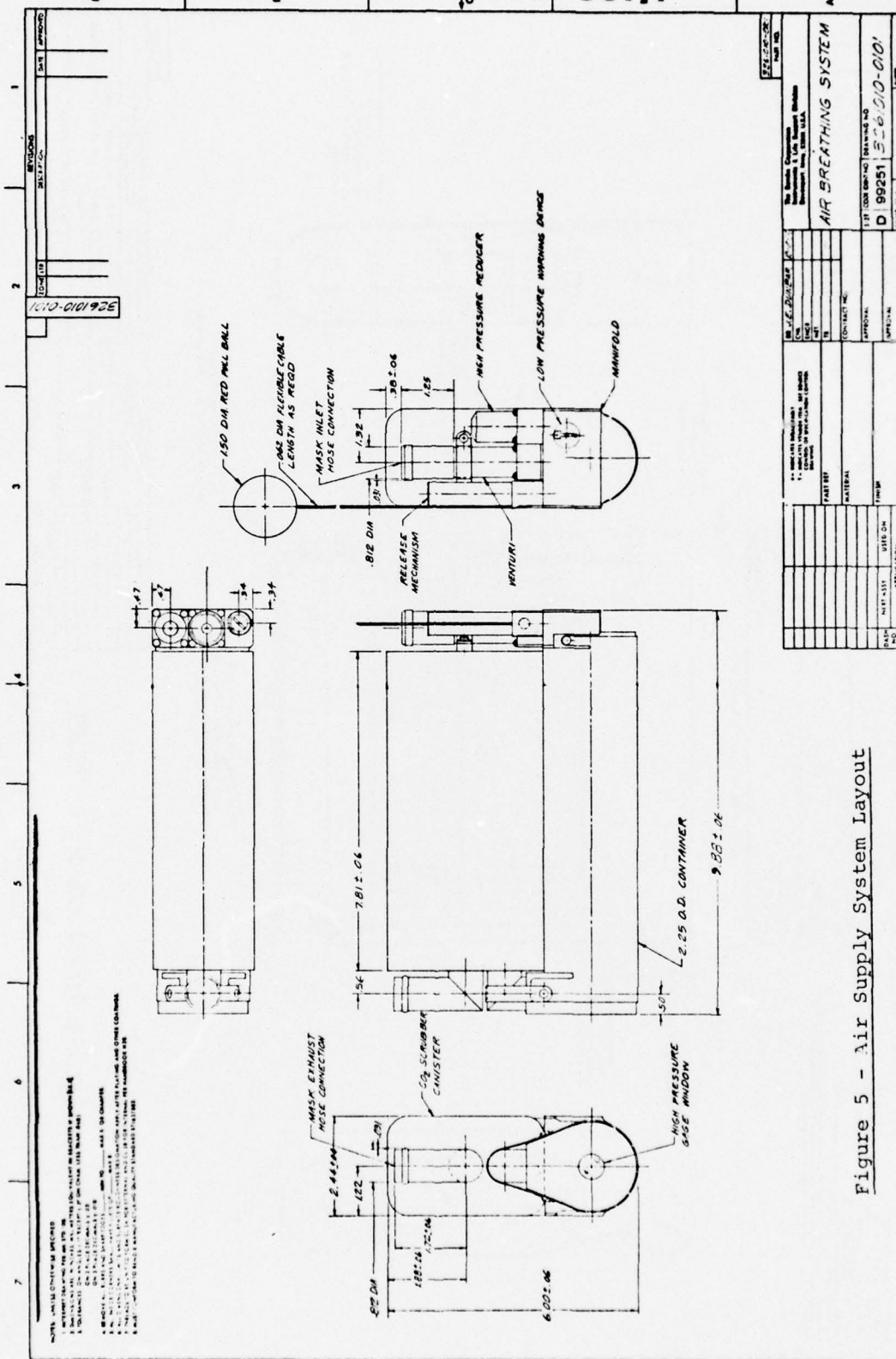
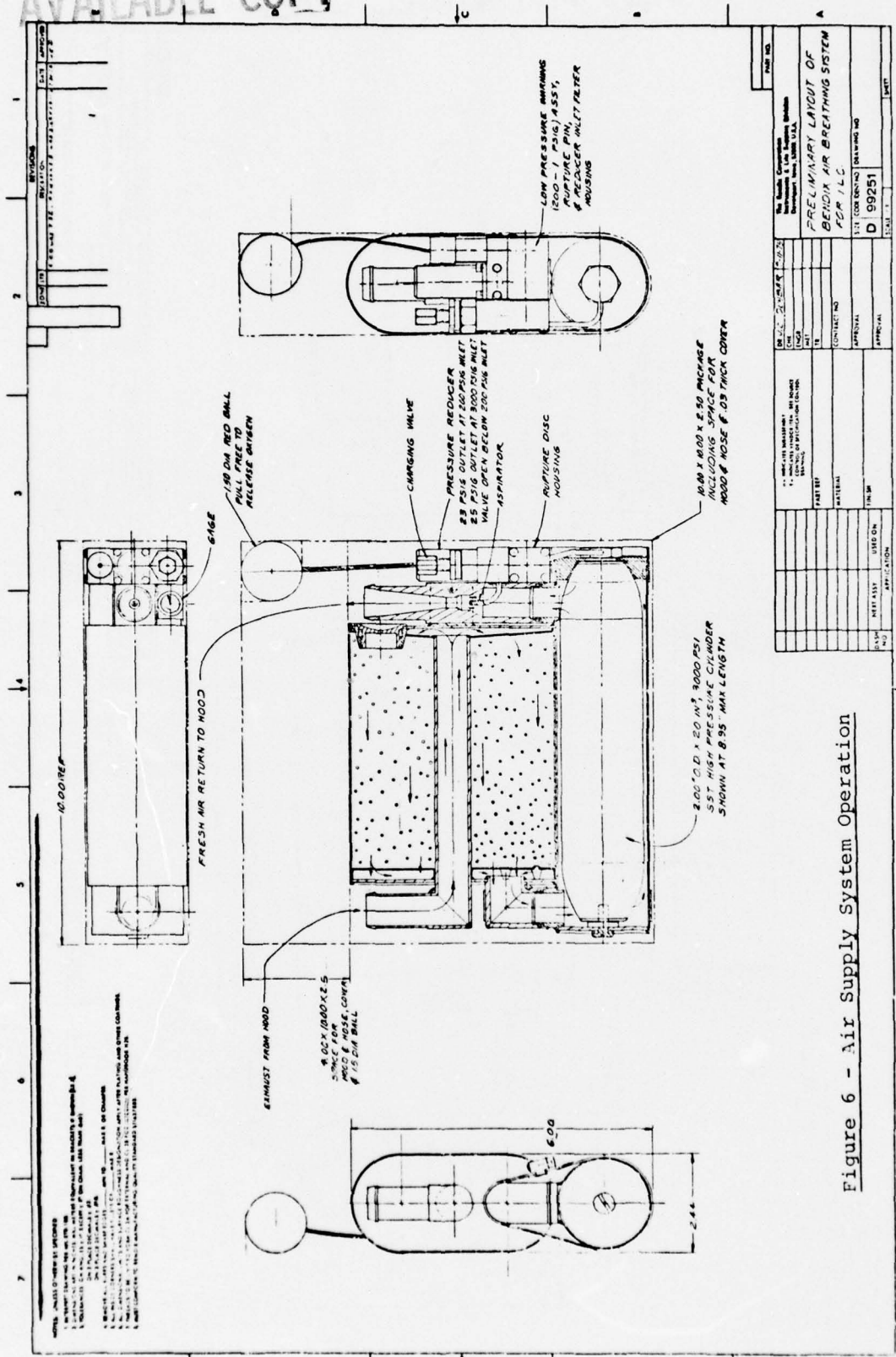

Figure 5 - Air Supply System Layout

TITLE: AIR BREATHING SYSTEM DRAWING NO: D 99251 REV: 32-610-010 DATE: 11-1-58	
PROJECT: AIR BREATHING SYSTEM DRAWING NO: D 99251 REV: 32-610-010 DATE: 11-1-58	PART NO: 32-610-010 MATERIAL: ALUMINUM FINISH: ANODIZED
MANUFACTURER: BENDIS ADDRESS: 1100 15TH AVENUE NEW YORK, N.Y. 10036	CHECKED BY: [Signature] APPROVED BY: [Signature]

BEST AVAILABLE COPY



NOTES: UNLESS OTHERWISE SPECIFIED:
 1. ALL DIMENSIONS ARE IN INCHES.
 2. DIMENSIONS IN PARENTHESES ARE IN MILLIMETERS.
 3. DIMENSIONS IN BRACKETS ARE FOR INFORMATION ONLY.
 4. DIMENSIONS IN SQUARE BRACKETS ARE FOR INFORMATION ONLY.
 5. DIMENSIONS IN DASHES ARE FOR INFORMATION ONLY.
 6. DIMENSIONS IN SLASHES ARE FOR INFORMATION ONLY.
 7. DIMENSIONS IN UNDERSCORES ARE FOR INFORMATION ONLY.
 8. DIMENSIONS IN SUPERSCRIPTS ARE FOR INFORMATION ONLY.
 9. DIMENSIONS IN SUBSCRIPTS ARE FOR INFORMATION ONLY.
 10. DIMENSIONS IN SMALL CAPS ARE FOR INFORMATION ONLY.
 11. DIMENSIONS IN ALL CAPS ARE FOR INFORMATION ONLY.
 12. DIMENSIONS IN LOWER CASE ARE FOR INFORMATION ONLY.
 13. DIMENSIONS IN MIXED CASE ARE FOR INFORMATION ONLY.
 14. DIMENSIONS IN ITALIC ARE FOR INFORMATION ONLY.
 15. DIMENSIONS IN BOLD ARE FOR INFORMATION ONLY.
 16. DIMENSIONS IN STRIKEOUT ARE FOR INFORMATION ONLY.
 17. DIMENSIONS IN UNDERLINE ARE FOR INFORMATION ONLY.
 18. DIMENSIONS IN WAVE UNDERLINE ARE FOR INFORMATION ONLY.
 19. DIMENSIONS IN DOTTED UNDERLINE ARE FOR INFORMATION ONLY.
 20. DIMENSIONS IN DASH UNDERLINE ARE FOR INFORMATION ONLY.

THE QUALITY CONNECTION 1000 WASHINGTON BLVD. WASHINGTON, D.C. 20001 (202) 462-1000 FAX (202) 462-1001	
PROJECT NO. 99251	DRAWING NO. D 99251
TITLE PRELIMINARY LAYOUT OF BENDIX AIR BREATHING SYSTEM PER ILC	DATE 11/11/88
DRAWN BY WATERMAN	CHECKED BY [Blank]
DESIGNED BY [Blank]	APPROVED BY [Blank]
DATE 11/11/88	SCALE 1:1

Figure 6 - Air Supply System Operation

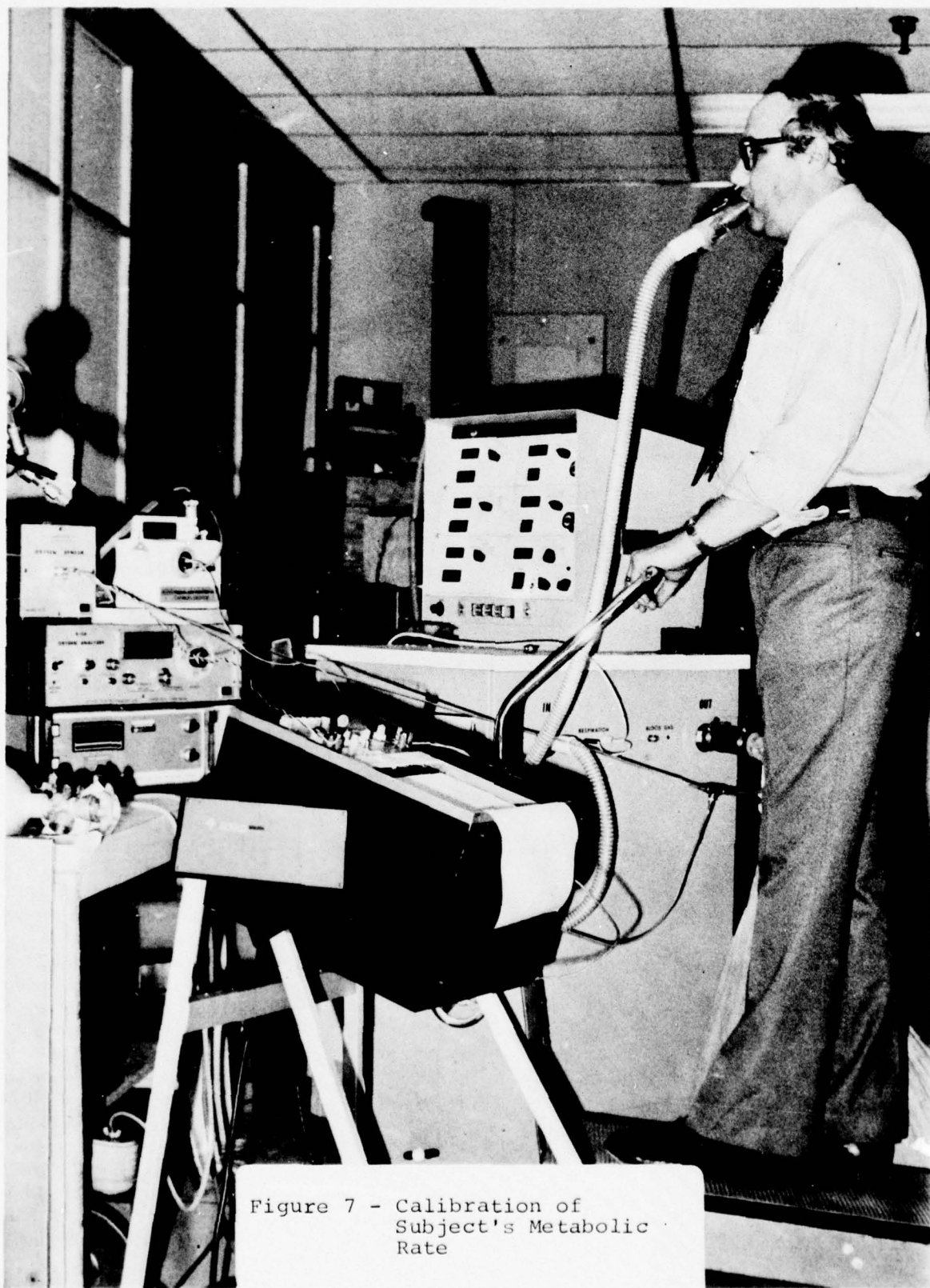

Figure 7 - Calibration of
Subject's Metabolic
Rate

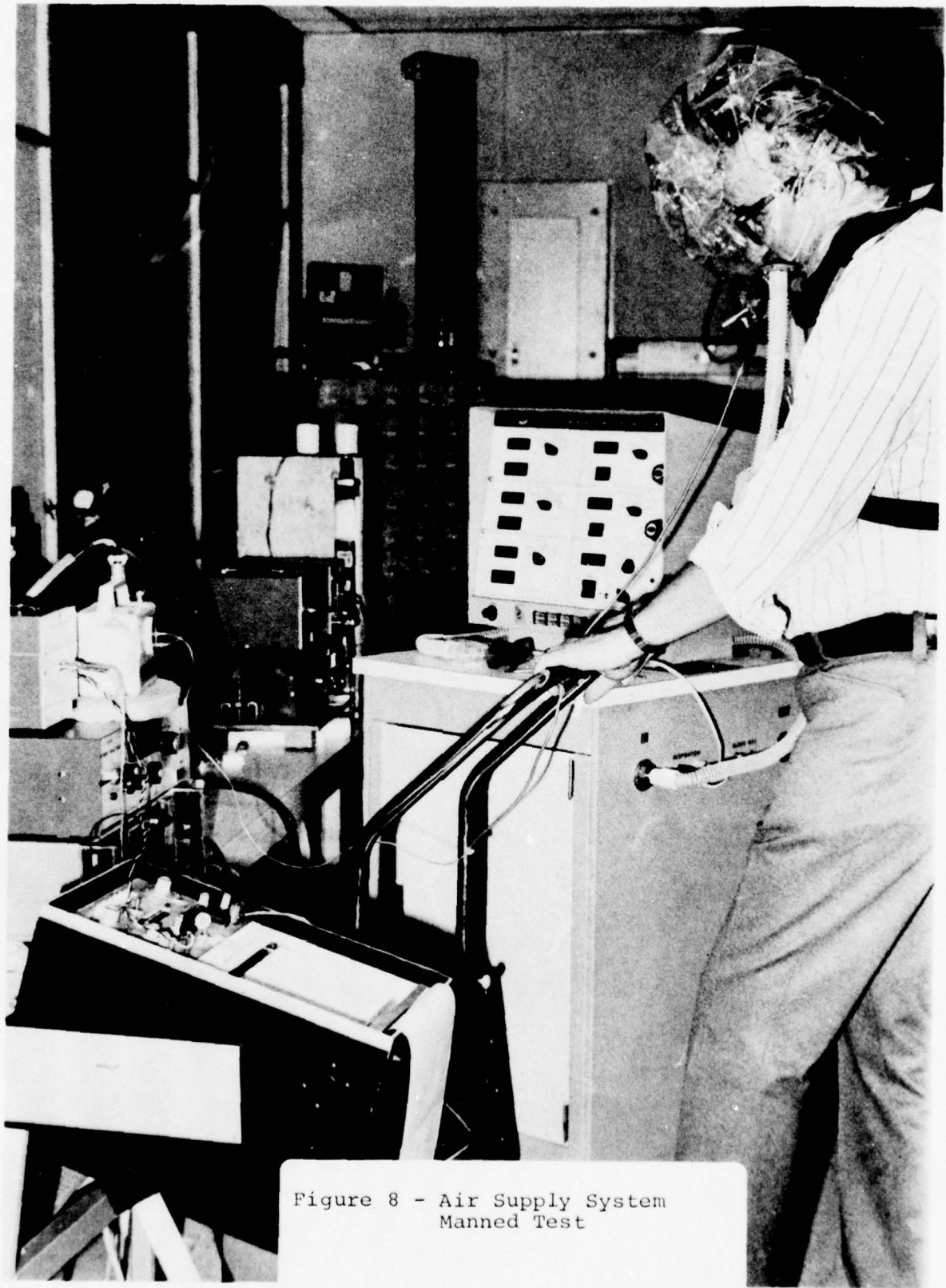

Figure 8 - Air Supply System
Manned Test

ENGINEERING DEPARTMENT DATA BOOK

E. P. NO. 20256

SUBJECT EXERCISE TEST @ 3.5 MPH

DATE 11-20-75

TEST NUMBER D. HINDS @ 154 LBS.
HOOD TEMP. 82-97°F.

GROUP _____

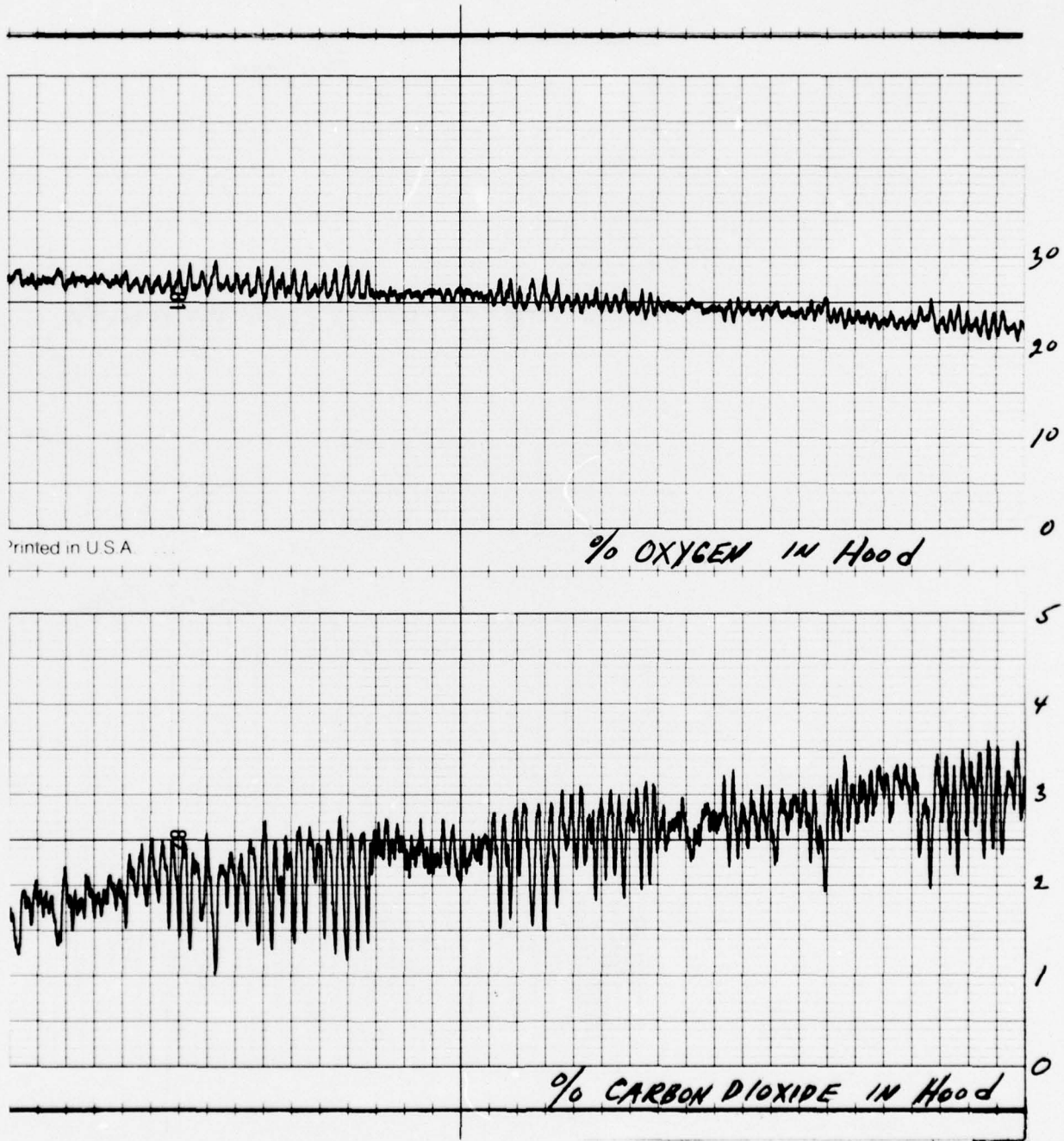

Figure 9 - Air Supply System Manned Test Results
Instruments & Life Support Division Davenport, Iowa

ENGINEERING DEPARTMENT DATA BOOK

E. P. NO. 20256

SUBJECT 3261010-0101 ILC BREATHING SYSTEM DATE 11-21-75

TEST NUMBER JOHN HENNEMAN @ 200 LBS. GROUP _____
METABOLIC RATE AT 3.5 MPH

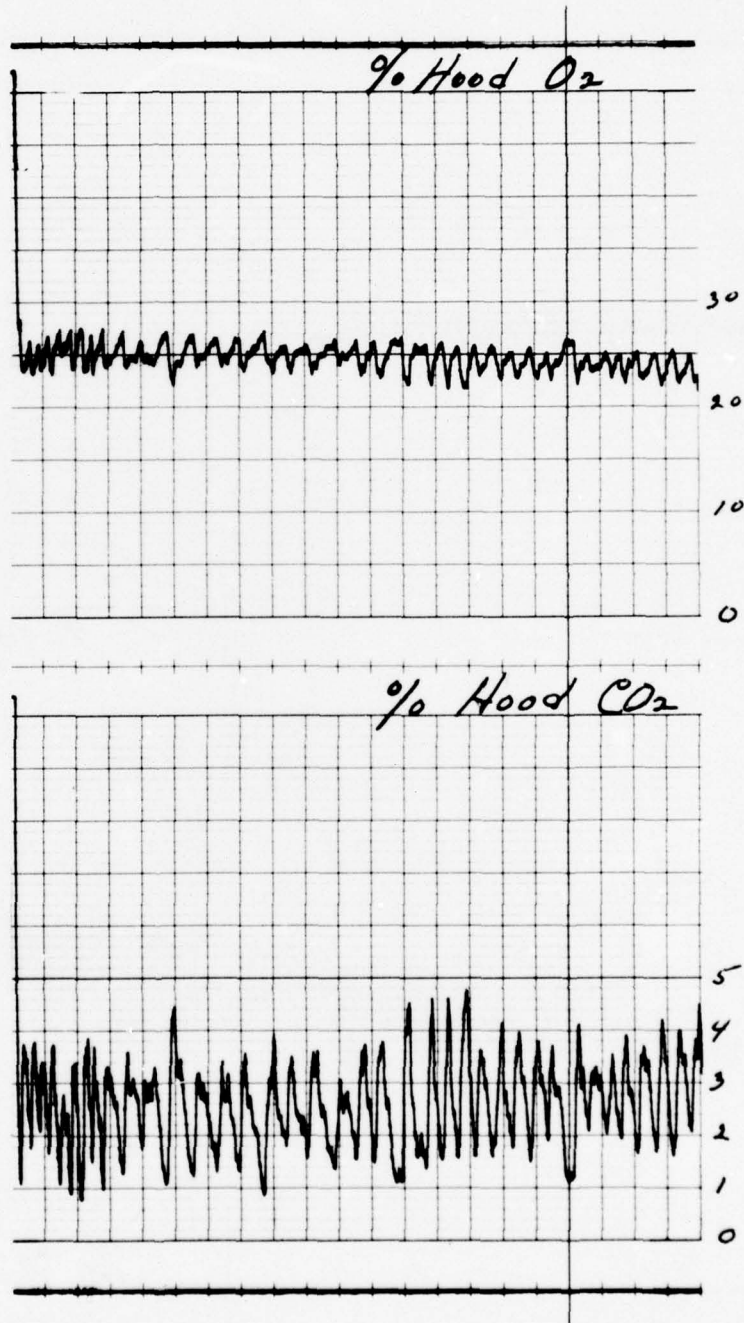

Figure 10 - Air Supply System Manned Test Results

Instruments & Life Support Division Davenport, Iowa

gas flow path created an unacceptable increase in flow-path resistance. For example, insertion of a 1/2-inch long plug of open-cell polyurethane foam in the hose increased the pressure drop, at 60 LPM flow, from 0.1 inches H₂O to 12.0 inches H₂O; noise cancelling was considerable, however.

A "straight-thru" muffler approach proved quite effective in reducing the jet noise of the system. A major effort to develop and fabricate a hose with an integral muffler was beyond the scope of this program. It was rather simple, however, to demonstrate the feasibility of the approach. An MS22055H12 breathing hose was stripped of its covering over a 3-inch length, leaving only the bare wire reinforcement. A pad of 1/2-inch thick open-cell polyurethane foam, 4 inches long, was wrapped around the opening in the hose and taped in place, completely surrounding the stripped portion of the hose. Additional tape was applied to form a gas-tight seal between the hose and outer perimeter of the foam.

An unmodified hose was installed on the exit side of the air supply system. With the system actuated, a sound level of 85 db was measured at a point 3 inches from, and perpendicular to, the hose outlet. When the modified, straight-thru muffler hose was installed, the sound level at the same position was 68 db. Tests showed no measurable difference in flow resistance between the modified and unmodified hoses at flows up to 12 CFM (340 LPM). Figure 11 shows the modified and unmodified hoses.

This modification, though very effective, is not necessarily optimum. Optimization would consider foam type, thickness, length, placement, etc.

The weight of the prototype air supply system is 5.2 pounds, including a stainless steel CO₂ removal canister. Bendix estimates that the use of a plastic canister and other design/material changes incorporated in a production article would reduce the system weight to approximately four (4) pounds.

A warning statement is affixed to the air supply system to inform users that the tank should be charged with a gas mixture with at least 40% oxygen. This is required because, as oxygen is consumed by the user, the partial pressure of O₂ decreases steadily and CO₂ is continuously removed by the CO₂ scrubber. The end result of using the system, charged with normal air, for the full eight minutes, could be a very low partial pressure of oxygen and CO₂ and the ensuing consequences of hypoxia.

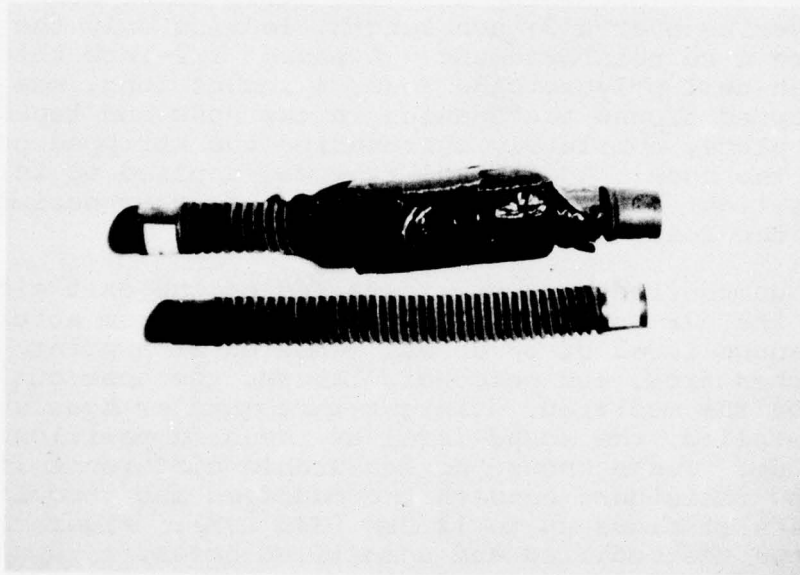

Figure 11 - Modified and Un-modified
Breathing Hoses for
Noise Reduction

6.0 PROTOTYPE SIZING, FABRICATION, AND INTEGRATION

When materials and configuration were decided upon, fabrication of the prototype garment commenced. Patterns were generated for a pullover garment with an integral hood and hood cover. (Figure 3). It was desirable to fit as large a population of flight attendants as possible with a single size. A study of available anthropometric data, including a survey of stewardesses by FAA Civil Aeromedical Institute (Ref. 2) and USAF data on male flying personnel (surveyed in 1967, unpublished), provided guidelines for garment sizing. Key parameters included shoulder-height (standing), chest circumference, arm length, neck circumference (for the neck-seal in the hood), and hand dimensions (for glove sizing). This study indicated that the pullover garment could accommodate a wide range of users, from the 5th percentile female to the 95th percentile male of the populations studied. It was concluded that a garment of this configuration, of sufficient size in the key dimensions to fit the largest male users, would also be adequate for the smallest female users. The only compromise was in the skirt length: the taller the user, the less protection would be afforded the lower extremities by the garment. Since the cabin-fire environment and full-scale tests indicated that the cabin fire below knee level is minimal, this was not felt to be a significant design compromise.

A critical overgarment dimension was arm length. The user must insert the hands into the gloves completely and thereafter be able to perform all required tasks with the gloved hands. This was achieved by the incorporation of an internal elastic wrist-band in the garment sleeve, so that when the hand was inserted in the glove, it was retained there, regardless of the user's arm length.

Based on the anthropometric analysis, patterning was developed. This process required the standard two steps. The first step was to lay out "slopers" - patterns that closely follow the contour of the shape to be fitted. These "slopers" were then checked out, and adjusted as required, on selected female and male subjects. The next step was to add easements to these slopers to allow for rapid donning/doffing, individual dimensional variations, breathing system inclusion, and ease of fabrication. The process of translating anthropometric data to patterns for a particular configuration of garment is very much an art and a product of the individual patternmaker's ability and experience. The patterns thus produced for this garment are simply one definition of the prototype size and shape. Therefore, the patterns

delivered as end items of this effort should not be considered as controlling, but as guidelines for any future related effort that might be undertaken.

In addition to the overall size, shape, and cross-section of the garment, seam structure and stitching were defined. All seams were designed to turn cut ends inward, so as to always present the outer aluminized layer to the thermal flux. All stitching was done with Nomex thread. Thermal exposure of Nomex stitched seams in the laboratory proved their adequacy for this application. Since hot-knife cutting of plain fabrics woven from high-temperature materials, such as used in the Durette liner, is not possible, the liner fabric was edgelocked with "Kel-F-100" after marking and prior to cutting. The aluminized Kynol and glass layers and the Kynol-battling insulation layer required no edgelocking. The breathing hood was procured from H. T. Sheldahl Corporation and modified for this application. It is a 1 mil Kapton (uncoated) unit designed for use in a fire environment to protect the wearer from smoke, fumes, and super-heated air for short periods. It was ideal for this application because it was of the chosen material (Kapton film), had the size and type of neck-seal desired, and was of the size and shape required to fit the garment hood-cover. Modifications to the Sheldahl hood included: addition of adhesive/heat-sealed PVC flanges to mate with breathing system hoses; installation of the relief valve in the rubber neck seal, and incorporation of Kevlar loop-tapes and lacing cord to anchor the hood to the garment and hood-cover. With the hood installed and anchored to the garment, it becomes an integral part of the assembly. When the garment is pulled down over the head, the head is automatically inserted thru the neck-seal and into the hood.

The breathing hoses were installed on the air supply system with hose clamps. The assembly was then placed in the pocket on the inside back of the garment and the pocket closed by means of a flap with a Velcro closure. The hoses were routed up the back in the garment in anti-snap covers which were also closed with Velcro. The top ends of the hoses were cemented into the PVC flanges on the back of the hood using a neoprene-base adhesive. With this arrangement, the breathing system including hoses and hood can be de-integrated easily for inspection and servicing, without damaging either the garment or breathing system. A port in the air supply pocket allows visual checking of the supply pressure gage without removing any of the components or opening any of the closures.

7.0 FULL-SCALE DEMONSTRATIONS

When fabrication and integration of the prototype Protective Overgarment was completed, preparations were made to perform demonstrations of donning and mobility and of garment protective ability in the design fire environment.

7.1 DONNING AND MOBILITY DEMONSTRATION

Prior to conducting the cabin demonstration, procedures were developed that minimized the amount of time required to retrieve and don the garment. With a few minutes practice, a subject consistently was able to don the garment in ten seconds or less. The stowage arrangement for the garment, which promoted rapid retrieval and donning, is shown in Figure 12.

The demonstration was performed in a retired B-707 fuselage at the FAA's NAFEC facility, New Jersey. The cabin aft interior and galley areas were intact and in good condition. The hatches and escape exits were operable. The demonstration was documented on 16 mm color film.

The garment was stowed on a shelf in the galley area, next to a flight attendant's jump seat. The demonstrator, an adult female wearing a pant-suit, performed several sequences of retrieval and donning. Each sequence was filmed with a clock with a sweep second hand in the camera field of view. Next, with the garment donned, she performed demonstrations of actions likely to be required of a flight attendant in a cabin fire situation: overhead reach; retrieval of stowed items (such as a bull-horn); crawling; operation of escape exit; walking; running; and garment doffing.

Results were generally satisfactory. Donning was demonstrated to be possible within the required ten (10) second limit. All actions were performed well, although crawling was somewhat hampered by the skirt of the garment getting under the knees; this was alleviated by crawling on the hands and toes, rather than hands and knees. No significant degradation of performance or visual field was evident or reported by the subject. As a result of wearing the garment for about 30 minutes on a warm summer day, the Durette liner of the garment became wet with perspiration. In this condition the Durette, which was chosen mainly for its smoothness for ease of donning and doffing, became sticky and clinging, making both donning and doffing difficult. However, this did not occur during the 8-minute garment design period.

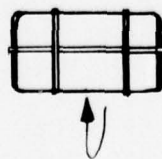
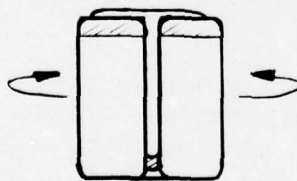
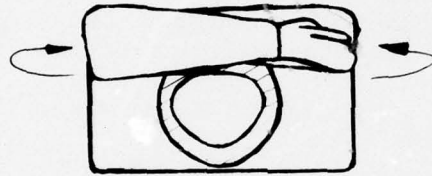
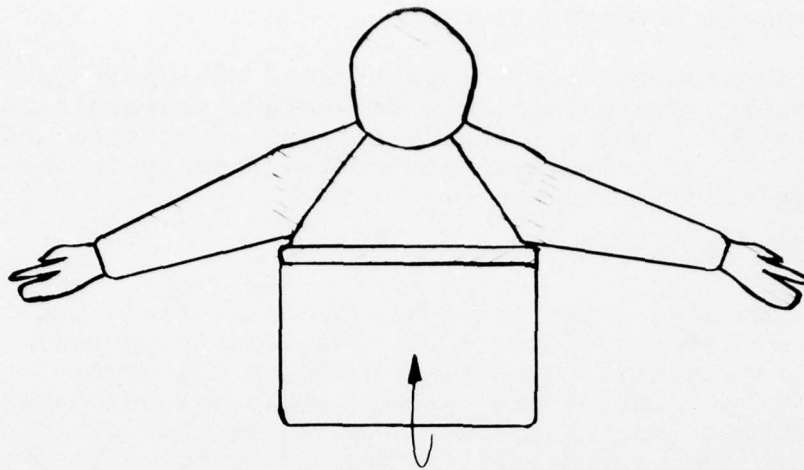

Approximate Packed
Dimensions:

15-in. Long
10-in. Width
8-in. Depth

Figure 12 - Garment Preparation for Stowage

The repeated donning and doffing of the garment, prior to and during the demonstration, resulted in damage to the hood. The Kapton film and neck-seal were torn in several places. The Kapton film is believed to have been torn during the garment doffing part of the demonstration, since operation of the breathing system prior to that time completely inflated the hood, and the tear was large enough to have vented all of the breathing air flow and thus preclude inflation of the hood. The tears in the neck-seal were attributed to age deterioration of the natural rubber material. The seal material was gummy and plastic, which is characteristic of reverted natural rubber. The Kapton film tears were repaired by the application of Kapton tape. The neck seal was replaced using new natural rubber film.

SIMULATED CABIN-FIRE DEMONSTRATION

The objective of this task was to evaluate the ability of the Protective Overgarment to protect the user against the design environment specified in paragraph 2.0(f).

This demonstration was conducted at the Naval Air Development Center, Warminster, PA. under a separate inter-agency agreement between DOT and NADC, Warminster, PA. A complete narrative of this effort, with detailed data and results, is included in Appendix B of this report.

Instrumentation Data, Table III, Appendix B, shows that skin temperatures in the right breast, throat, and left forearm areas indicated pain would have been produced in a human subject at those locations.

It is likely that the predicted pain levels would cause a live subject to move inside the garment, to reposition his body, or to turn relative to the fire. Without live subject testing, it is impossible to establish to exactly what degree such actions would be required and thus whether or not the overgarment design tested is unacceptable.

Since laboratory testing of the garment materials layup showed it should provide adequate protection against the radiative heat flux, it must be concluded that the convective heat transfer present in the full scale test was significant, and the combination of it and the radiative heat transfer was sufficient to raise the temperature of the inner layer of the garment to unacceptable levels in several places. The thermal protection of the garment could be increased by making the insulating Kynol batting thicker, at the cost of increased bulk and weight.

The high temperatures of the face of the protected manikin were probable, since the film material was not metallized in order to maximize visibility. Any further hood development would have to include a trade-off study between optics of visual field and convective heat transfer through the hood visor.

8.0

CONCLUSIONS

Based upon the efforts and results related in the foregoing sections, several conclusions can be stated at this time. These are in addition to those cited in Appendix B.

- a. Both the state-of-the-art of available materials and backpack air supply precluded the original program goal of a garment which would look like a component of the flight attendant uniform and would protect against the thermal environment.
- b. All other requirements of the program Statement of Work either were met by the prototype or could be met with some minor further development effort. Specific areas would include: use of a visor section in the hood made from a metallized clear plastic such as polycarbonate or polysulfone; increased thickness of insulation in the garment cross-section; and improved thermal resistance of the aluminized outer layer, or use of other metallized outer layer, such as goldized Kapton laminated to a fabric substrate.
- c. The original goal of a styled, colored, wear-on-takeoff/landing garment may be approachable when the NASA developed polyimide material becomes commercially available. The breathing system would still have to be designed and integrated to prevent localized injury in event of survivable crash.
- d. The cabin demonstration test showed that a flight attendant could function effectively with the overgarment donned and could perform all actions that might be required in a cabin fire emergency.
- e. The full-scale fire exposure demonstrated that an unprotected flight attendant could not function effectively close to a localized, cabin fire similar to the test fire. An attendant wearing the prototype garment could still be forced to take some action to avoid the development of local hot spots on the body. Also pointed up by the fire test was the fact that the severity of the thermal environment is reduced by significantly good cabin ventilation to remove heat and prevent flashover.

f. Based upon prototype fabrication, including actual material and labor costs, the following estimated production costs were developed for a run of 2,000 units:

Overgarment	\$ 290
Air Supply System	\$ 345
Hood (with hoses)	<u>\$ 25</u>
Total Unit Price	\$ 660 (1976 Dollars)

These prices would, of course, be affected by greater or lesser quantities, and costs of additional development to refine design details, reduce weight, or otherwise improve the prototype assembly.

g. Weights (actual):

Overgarment and Hood	5.0 lbs.
Breathing System	<u>5.2 lbs.</u>
Total	10.2 lbs.

(Additional conclusions are contained in Appendix B.)

9.0

REFERENCES

1. R. Stuckey, D. Supkis, and L. Price (1974) Full-Scale Aircraft Cabin Flammability Tests of Improved Fire-Resistant Materials, NASA Tech. Memo. TM X-58141.
2. C. Snow, H. Reynolds, and M. Allgood, Anthropometry of Airline Stewardesses, D.O.T. Report FAA-AM-75-2, March, 1975.
3. N. Sax (1968), Dangerous Properties of Industrial Materials, Reinhold Book Corp., New York
4. V. Carter, Jr., D. Bofus, H. Warrington, and E. Harris (1974). The Acute-Inhalation Toxicity in Rats from the Pyrolysis Products of Four Fluoropolymers. Toxicology and Applied Pharmacology 30, 375.
5. A. M. Stoll, Thermal Protection Capacity of Aviator's Textiles, Aerospace Medicine, July, 1962.

APPENDIX A

BREATHING SYSTEM SPECIFICATION,
TEST DATA, AND RECHARGE INSTRUCTIONS

SP1636840

1. SCOPE

1.1 Scope. This specification establishes the requirements for an Air Breathing System, Bendix type number 3261010-0101 (hereinafter referred to as the System). Bendix, as used herein, refers to the Instruments & Life Support Division of The Bendix Corporation.

2. APPLICABLE DOCUMENTS

2.1 The following documents are considered a part of this specification to the extent specified herein.

DRAWINGS

Bendix

3261010-0101

Air Breathing System

3. REQUIREMENTS

3.1 Item definition. The System shall provide a recirculating positive pressure of air to the hood of a Protective Overgarment for use by Air Carrier Flight Attendants.

3.1.1 Materials. The materials used in the fabrication of the System shall be of a quality which experience and/or tests have demonstrated to be suitable and dependable for use in a life support system. All metal parts shall be of a corrosion-resistant material or suitably treated to resist corrosion. The 3000 psi cylinder shall be 304 stainless steel and the flow manifold and pressure reducer shall be anodized aluminum. All seals and "O" rings shall be silicone rubber.

3.1.2 Design. The System shall conform to Drawing 3261010-0101 where the user wearing a hood with neck seal to encapsulate his head is supplied with a constant flow of gas to ventilate the hood with sufficient circulation to keep the hood slightly pressurized with a physiologically safe breathable gas mixture. To achieve proper circulation of a safe, breathable gas, an injector fed from a high pressure supply of an oxygen-rich air mixture is used to pull the gas from the hood through a chemical canister to scrub out CO₂ and absorb water vapor and flow the purified gas back into the hood.

3.1.2.1 The System shall consist of the following components:

- a. Cylinder, 3000 psi, 20 cu. in. with pressure gage.
- b. Canister, with 55 cu. in. sodasorb.
- c. Fill and Actuation Mechanism.
- d. Pressure Reducer and Venturi-Aspirator Assembly.
- e. Flow Manifold and Cylinder Retainers.
- f. Low Pressure Warning Device.

SIZE	CODE IDENT NO.	
A	99251	SP1636840
SCALE	A-3	REV. A
		SHEET 2

SP1636840

3.2 Performance.

3.2.1 Gas volumes. The System must provide a minimum of eight (8) minutes of respiratory support during metabolic rates of 1500 BTU/hour. It must supply adequate oxygen and tidal volume of respirable gas to meet a demand (oxygen consumption rate) of 2.5 lpm (STPD) of oxygen uptake. In addition to satisfying the oxygen demands, the system must supply breathable gas volumes of 60 lpm (BTPS) ventilation rate. The oxygen content of the inspired gas shall be a minimum of 19% by volume.

3.2.2 Percentage of carbon dioxide. The mean inspired CO₂ for a single breath shall not exceed a volume fraction greater than 3%.

3.2.3 Gas temperature. The inspired gas temperature shall not exceed 100°F.

3.2.4 Altitudes. The System shall be capable of operating at altitudes up to 15,000 feet.

3.3 Design and system components. The System shall consist of the following components:

a. Oxygen Source. Oxygen shall be supplied from a 20 cubic inch, 3300 psig cylinder that has been filled with a 40% O₂ 60% N₂ air supply.

b. Carbon Dioxide Canister. Carbon dioxide shall be removed from the inspired air by passing through a 55 cubic inch canister filled with 1.6 pounds of sodasorb.

c. Pressure Reducer. The pressure reducer shall reduce the System pressure from the cylinder 3000 psig to the aspirated pressure of 23 to 26 psig.

d. System Pressure Relief Valve. The System shall contain a pressure relief valve set at one inch of water pressure and mounted in the Air Breathing System Hood.

e. The System also includes: (a) Venturi-Aspirator Assembly; (b) Fill and Release Mechanism; (c) Flow Manifold and Cylinder Container; (d) Pressure Gage; and (e) Inlet-Outlet Hoses.

3.4 Physical characteristics.

3.4.1 Weight. The weight of the prototype System shall be 5.2 pounds to allow recharging of the gas storage vessel and replacement of the sodasorb. The final production hardware will be approx. 4.5 pounds based on canister proposed weight, tooling, and material.

3.4.2 Dimensions. The dimensions of the System shall be as defined by Drawing 3261010-0101.

SIZE	CODE IDENT NO.	
A	99251	SP1636840
SCALE	A-4	REV. A
		SHEET 3

SP1636840

3.4.3 Instruction decal. A decal containing instructions on the use, donning and operation of the System shall be permanently affixed to the System.

3.4.4 Shelf life. The System shall be designed for a minimum shelf life of three (3) years and a minimum wear of one (1) year. Shelf life is to be interpreted as that period of time that an item may be stored on a shelf and still perform its desired function when activated. Wear life is to be interpreted to mean that period of time after issue when the unit is being carried by Flight Personnel. It may remain unactivated, but it must be capable of performing its desired function at any time.

3.5 Acceptance testing. During fabrication and/or assembly the following individual tests shall be performed or checked for prior test data:

- a. Gas cylinder only - Proof Pressure @ 5000 psi
- b. Cylinder and Valve Assy. - Pressure Test @ 3000 psi
- Gas Leakage @ 3000 psi - [] lpm.
- c. Venturi-Aspirator - Ventilation rate of 60 lpm @ max.
Aspirator flow of 8 lpm.
- d. Overall Body Leakage - @ 3000 psig no leak at Aspirator, Fill, and Release Mechanism.

4. QUALITY ASSURANCE PROVISIONS

4.1 Sampling (one unit from every 100 units or fraction thereof) shall be subjected to the following test program.

4.1.1 Sampling A

- (a) Examination of product (4.2.1)
- (b) Proof pressure, cylinder only (4.2.4)
- (c) Leakage, overall body (4.2.5)
- (d) Actuation force (4.2.6)
- (e) Duration, ventilation rate (4.2.7)
- (f) Dimensional and Weight (4.2.2 and 4.2.3)

4.1.2 Sampling B

- (g) Hood gas analysis (4.2.8)
- (h) Hood gas temperature (4.2.9)

4.2 Test methods.

4.2.1 Examination of product. The System shall be examined to be free from extraneous materials and defects in workmanship.

SIZE	CODE IDENT NO.		
A	99251	SP1636840	
SCALE	A-5	REV.	SHEET 4

SP1636840

4.2.2 Dimensional. The System shall be examined for compliance with the requirements of Drawing 3261010-0101.

4.2.3 Weight. The System shall not exceed 5.2 pounds in weight when charged with 3000 psig air and 1.63 pounds of sodasorb.

4.2.4 Proof pressure. The gas cylinder only shall be subjected to 5000 psig and held for at least 30 seconds. There shall be no mechanical deformation or failure.

4.2.5 Leakage, overall body. The complete System shall be assembled and charged to 3000 psi. At this pressure and with the air shut-off screw (20256-36) fully open, there shall be no evidence of leakage from the manifold housing and actuating spring housing.

4.2.6 Actuation force. With the System charged to 3000 psi, the force to pull the Red Apple and thereby actuate the System shall not exceed 10 pounds. The loaded and retained cable and ball assembly must be capable of withstanding a minimum force of 10.0 pounds while being rotated 360 degrees in a plane perpendicular to the longitudinal axis of the attached Air Cylinder and CO₂ Canister.

4.2.7 Duration, ventilation rate. The test unit shall be worn by a test subject walking on an inclined treadmill at a rate of 3.5 mph requiring up to 2.5 liters of oxygen consumption and a ventilation of 60 lpm for eight (8) minutes.

4.2.8 Respiratory gas analysis. Inspired and expired oxygen and carbon dioxide concentrations shall be measured continuously at the mouth on a breath-by-breath basis by mounting probes connected to appropriate instrumentation to determine conformance with the requirements of paragraphs 3.2.1 and 3.2.2.

4.2.9 Hood temperature. The temperature of the inspired gas shall be monitored and recorded by placing a sensor in the hood while gas is delivered to the test subject walking on an inclined treadmill at a rate of 3.5 mph. The measured temperature shall not exceed 100°F during an eight (8) minute test.

SIZE	CODE IDENT NO.	
A	99251	SP1636840
SCALE	A-6	REV. /
		SHEET 5

3/2/76

TEST DATA
ON
TYPE 3261010-0101

EMERGENCY ESCAPE BREATHING APPARATUS

Purpose: To determine compliance of the Bendix 3261010 E.E.B.S. with the requirements of ILC Statement of Work dated 7/9/75.

<u>Test Requirements</u>	<u>Spec. Para. Ref.</u>	<u>Results</u>
1. EEBS without hood and hoses.	SP-1636840	B/U 001E
1.2 <u>Examination of Product</u> - The EEBS shall be examined to determine conformance to this specification with respect to materials, workmanship, and markings.	4.2.1	Complies with applicable specifications. SP 1636840 and 3261010-0101
1.3 <u>Dimensional</u> - The EEBS shall conform to Dwg. No. 3261010-0101	4.2.2	Conforms to dimension required of 3261010-0101
1.4 <u>Weight</u> - The EEBS shall not exceed 5.5 pounds for prototype model with refurbished sodasorb canister.	4.2.3	5.2 pounds with stainless steel canister (wt. 1 lb.)
1.5 <u>Cylinder Proof Pressure</u> - The cylinder shall be subjected to 5000 psig and held for 30 sec.	4.2.4	There was no mechanical failure or deformation of the cylinder.
1.6 <u>Leakage, Overall Body</u> - The EEBS completely assembled was charged with 3000 psig and leak tested.	4.2.5	There was no leakage from cylinder, manifold housing, or actuating spring house.
1.7 <u>Actuating Force</u> - With the EEBS charged to 3000 psi, the force to pull red apple shall not exceed 10 pounds.	4.2.6	Pull is 8.25 lbs.
1.8 <u>Duration, Ventilation Rate</u> - The EEBS duration shall be (8) eight minutes at a ventilation rate of 60 LPM. During a subject (Wt. 200 lbs.) running (treadmill) rate of 3 MPH, the EEBS shall support an oxygen uptake to 2.5 liters of oxygen.	4.2.7	The EEBS unit, only, on bench test will flow 60 LPM for 8 minutes and 20 sec. With test subject on an inclined treadmill at a rate of 3 MPH, max. O ₂ uptake monitored has been 2 liters. Unit is capable of up to 3 liters O ₂ consumption per minute.

<u>Test Requirements</u>	<u>Spec. Para. Ref.</u>	<u>Results</u>
1.9 <u>Respiratory Gas Analysis</u> - Oxygen and carbon dioxide concentrations shall be measured continuously to determine conformance of 19% min. O ₂ and 3% max. CO ₂ during the following exercise program: Rest 30 seconds; run 3 minutes @ 3 MPH; walk 1 minute @ 1 MPH; and run 3 minutes at 3 MPH.	4.2.8 3.2.4 3.2.2	Subject - (200 lbs.) Duration - 8 minutes Oxygen % - Max. 30% Min. 21% CO ₂ - Max. 3%
1.10 <u>Hood Temperature</u> - Temperature of inspired gas shall not exceed 100°F.	4.2.9	Subject 200 lbs. - Min. 82°F Max. 100°F 160 lbs. - Min. 82°F Max. 96°F
2. Development Test Data		
2.1 Min. Useable space for sodasorb	= 55 in ³	
2.1.1 Weight of sodasorb	= 1.63 pounds	
2.2 20 in ³ cylinder @ 3000 psi	= 63.4 liters of gas	
2.3 Pressure reducer setting	= 25 psi	
2.4 Venturi ratio 75:1	= 60 lpm (ventilation)	
2.5 Cylinder charge pressure	= 3050 psi with 40% oxygen	
2.6 Noise level, in hood	= Max. 85 decibel at air inlet hose	

RECHARGING INSTRUCTIONS FOR
BENDIX 3261010 BREATHING APPARATUS

1. Cylinder Charging Operation
 - 1.1 Unscrew spring retainer screw (33) and remove main spring (32) and stop rod (34).
 - 1.2 Remove rupture knife (31).
 - 1.3 Disassemble spring house (30) and remove rupture disc (1611697).
 - 1.4 CAUTION - "O" Ring MS 9020-05 must not be damaged (replace if required).
 - 1.5 Unscrew hole plug screw (37) with teflon seal ring. (See Note)
 - 1.6 Install charging adaptor fitting with pressure gage and MS fill check valve (20256-002).

2. Apply 40% O₂ 60% N₂ pressure to the fill-check valve and charging adaptor. *If pre-mix gas is not available, charge with oxygen to 1200 psig and then with nitrogen from 1200 psi to 3000 psig.
 - 2.1 Observe pressure gage and charge to 3000 psi.
 - 2.2 When 3000 psi is obtained, close shut-off screw (36) by rotating 180°, (1/2 turn).

3. Bleed fill charge pressure down by cracking "B" nut and disassemble adaptor fitting.
 - 3.1 CAUTION - "O" ring MS 9020-05 must not be damaged (replace is required).
 - 3.2 Install rupture disc (1611697) and spring housing (30). [Inspect "O" ring MS9020-04]
 - 3.3 Insert rupture knife (31) [inspect "O" ring MS9388-004] and cable/ball assembly (1624870), holding sleeve, load spring (32), stop rod (34), and adjust spring retainer screw (33).

NOTE: Adjust shut-off screw (36) to 1/2 turn open [180°].

- NOTE
4. Open shut-off screw (36) [rotate 360°-540° 1-1 1/2 turn] and install hole plug screw (37) with teflon seal ring.
 5. Regenerate Sodasorb Canister
 - 5.1 Remove fill cap and gasket (7) by unscrewing the two top 1/4 inch machine screws.
 - 5.2 Dump sodasorb from canister.
 - 5.3 Remove two rear 1/4 inch machine screws and posts (13)
 - 5.4 Remove two filters (9) - one from each end.
 - 5.5 Blow out canister to remove sodasorb dust.
 6. CAUTION - Canister must be Clean and Dry.
 - 6.1 Install new filters (9) by cutting one side near center in order to install around main return tube (add masking tape tab to hold joint in place).
 - 6.2 Replace two rear 1/4 inch machine screws and center posts (13) - place 1/4 inch screw in post threads to prevent filling with sodasorb.
 - 6.3 Add approximately 1.6 lbs. sodasorb - be sure sodasorb is tight against filters.
 - 6.4 Replace fill cap and gasket (7) and two top 1/4 inch screws.
 7. Seal canister inlet and outlet tubes until ready for installing on 3261010 breathing apparatus.

NOTES, UNLESS OTHERWISE SPECIFIED

1. INTERPRET DRAWING PER MIL STD-100
2. DIMENSIONS ON ANGLES TO BE EXCEPTED UNLESS SHOWN OTHERWISE
3. DIMENSIONS ON ANGLES TO BE EXCEPTED UNLESS SHOWN OTHERWISE
4. REMOVE ALL BURRS AND SHARP EDGES
5. ALL INSIDE CORNERS SHALL HAVE FILLETS OF RADIUS
6. PARTS TO BE FINISHED TO MIL STD-100 FOR INTERNAL AND CL 18 FOR INTERNAL PER HANDBOOK H2E
7. MUST CONFORM TO BENDIX MANUFACTURING QUALITY STANDARD 51637803

BEST AVAILABLE COPY

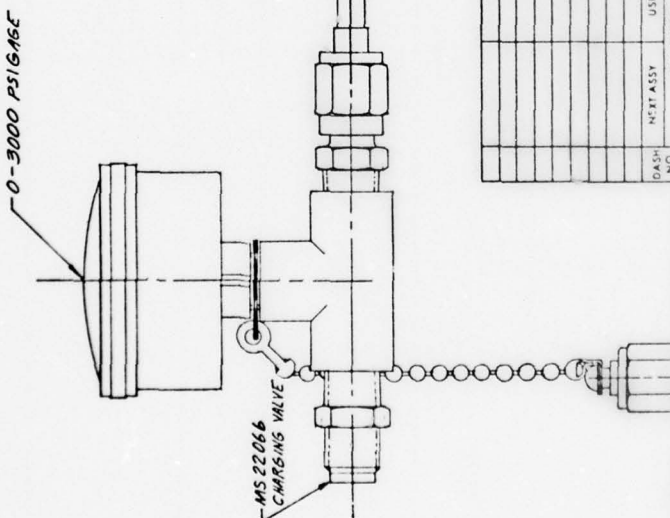
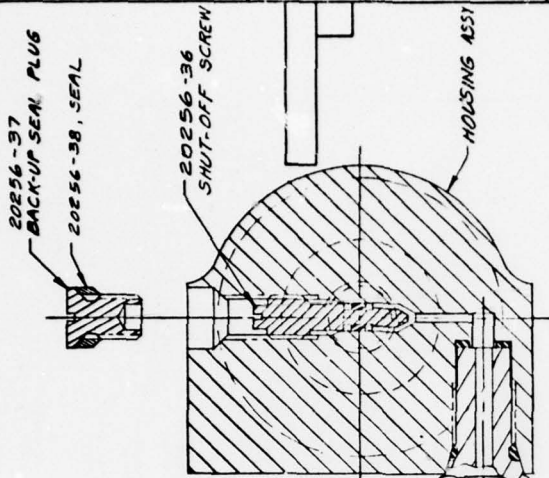

20E56-01
PART NO

The Bendix Corporation
Aircraft Equipment Division
Dayton, Ohio 45424, U.S.A.

CHARGING ADAPTOR
FOR BENDIX 32610-0101

SIZE CODE ENT NO DRAWING NO
C 99251

SCALE 1:1 SHEET

DRIVE DIMENSION	2-76
CHK	
ENGR	
DET	
TE	
CONTRACT NO	
APPROVAL	
APPROVAL	
** INDICATES SUBASSEMBLY	
* INDICATES VENDOR ITEM SEE SOURCE	
FOR SPECIFICATION CONTROL	
DRAWING	
PART REF	
MATERIAL	
FINISH	
DASH NO	
USED ON	
NEXT ASSY	
APPLICATION	

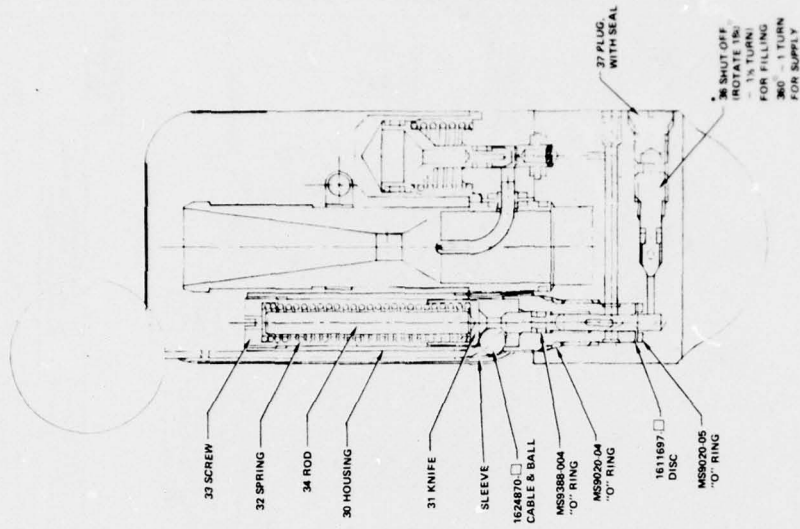
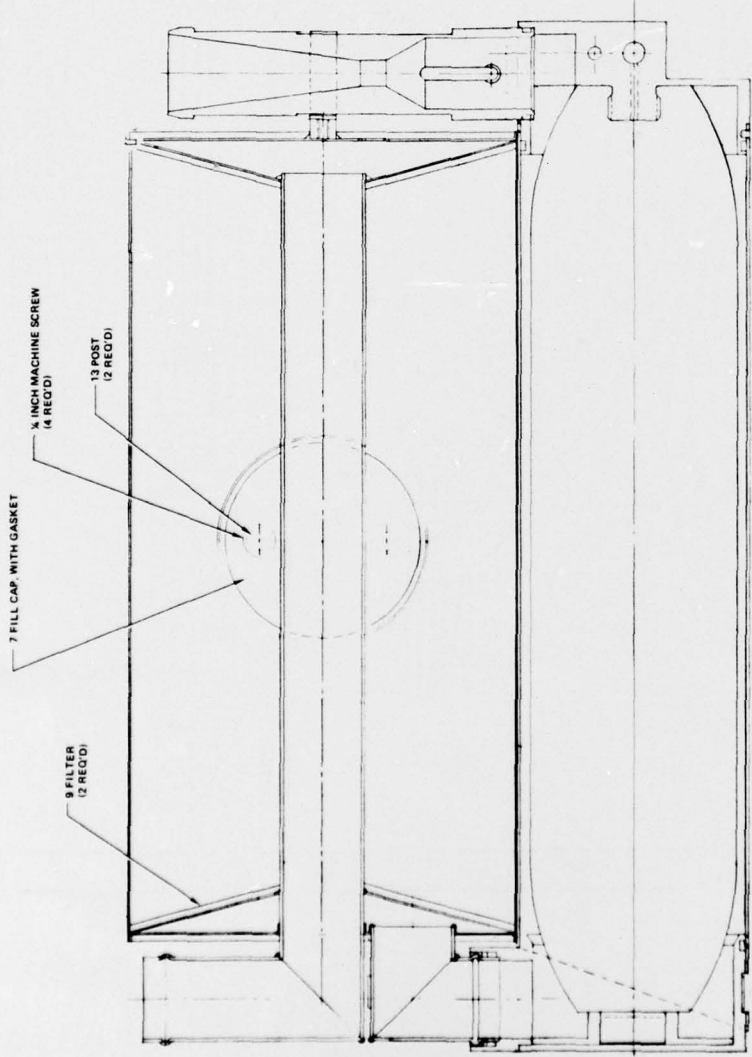

"INSTRUCTIONS FOR RECHARGING AIR BREATHING ASSEMBLY"

* CAUTION - SHUT OFF SCREW "38" MUST BE "OPEN" (ROTATE 90° - 1/2 TURN)

APPENDIX B

Evaluation of Thermal Protection
in Full-Scale Exposure of a Proto-
type Flight Attendants' Fire Pro-
tective Overgarment

A. M. Stoll, J. R. Piergallini,
M. A. Chianta, and D. E. Zaccaria,
Naval Air Development Center,
Warminster, PA

(Refer Navy Report NADC-76340-40)

T A B L E O F C O N T E N T S

	Page
OBJECTIVE	B-4
PROCEDURE	B-4
APPARATUS	B-4
RESULTS AND DISCUSSION	B-4
CONCLUSIONS	B-38
REFERENCES	B-41
LIST OF FIGURES	B-2
LIST OF TABLES	B-3

L I S T O F F I G U R E S

Figure	Title	Page
1	Test van	B-5
1A	Enclosure before fires	B-6
2	Manikins and instrumentation just prior to exposure	B-7
3	Radiation data preliminary run - 4 slab fire load	B-10
4	Air temperature data preliminary run	B-11
5	Radiometer locations - Front view	B-12
6	Location of manikins and instrumentation - Top view	B-13
7	Fire exposure of prototype garment	B-14
8	Manikins after exposure	B-15
9	Close-up of soot deposit on hood	B-16
10	Close-up of damage to unprotected ensemble	B-17
11	Air temperatures - Above 35°C	B-22
12	Air temperatures - Above 35°C	B-23
13	Air temperatures - Above 35°C	B-24

T A B L E O F C O N T E N T S (C o n t ' d)

Figure	Title	Page
14	Air temperatures - Above 35°C	B-25
15	Radiant flux	B-26
16	Radiant flux	B-27
17	Radiant flux	B-28
18	Radiant flux	B-29
19	Equivalent skin temperatures	B-30
20	Equivalent skin temperatures	B-31
21	Equivalent skin temperatures	B-32
22	Equivalent skin temperatures	B-33
23	Equivalent skin temperatures	B-34
24	Equivalent skin temperatures	B-35
25	Equivalent skin temperatures	B-36
26	Equivalent skin temperatures	B-37
27	Surface thermocouple locations - manikin	B-39
28	Paint blistered on manikin forehead	B-40

L I S T O F T A B L E S

Table	Title	Page
I	Comparison of experimental data and contract parameters	B-8
IA	Table I data rearranged with respect to time	B-8
II	Air temperature rise above 35°C (95°F) vs. time	B-19
III	Equivalent skin temperatures vs. time	B-20
IV	Radiant flux intensities vs. time	B-21

O B J E C T I V E

The objective of this work was to determine the burn protection afforded a flight attendant wearing a prototype garment (developed by a private concern under an FAA contract) for fire protection during emergency evacuation of an aircraft.

P R O C E D U R E

The procedure consisted of: 1) simulating a cabin fire involving about 4 seats; 2) exposing an instrumented, clothed manikin to the heat so generated for a period of approximately five minutes, the probable maximum emergency evacuation time during which a flight attendant could be assisting occupants to safety; 3) measuring manikin surface temperature rise with respect to time throughout the exposure for conversion to equivalent temperature rise in living skin; and 4) relating the measured quantities to pain and burn incidence that might be experienced by a flight attendant wearing the protective garment.

A P P A R A T U S

For implementation of the procedure outlined above, the interior of a mobile trailer van approximately 30 ft. long, 8 ft. wide and 8 ft. 6 in. high was contoured to represent one half of a B-727-B707 fuselage. All original flammable paneling, insulation and appurtenances were removed and curved sections of aluminum, 0.080 in. thick, were installed along one side to mimic the curvature of the fuselage. After a preliminary fire in which the aluminum contacted by the flames melted, steel sheets were substituted for the aluminum sheets adjacent to the fire and the aluminum sheets were retained elsewhere. The sides, ceiling and back of the curved section were insulated with Kaowool batting held in place by steel mesh where required. A rack was fashioned of angle iron to hold the fire load, i.e., five 18" x 36" x 4" slabs of urethane foam separated from one another by 1" air spaces. A trough was suspended beneath the rack to hold a small amount (1-2 oz.) of AvGas for igniting the slabs. The interior of the van before any fires were made is shown in figure 1 and 1A.

The height of the ceiling is 81 inches and the uppermost thermocouple of the tree of 10 is 1 inch below the ceiling. The distance of the thermocouple tree from the nearest foam slab is 68 inches and the manikin is placed 92" from this slab and inboard of the open side door. This position was selected as representing the probable location of a flight attendant during extreme conditions requiring evacuation from a door near a cabin fire. Positions of all thermocouples and radiometers are shown in precise measurement in inserts in the various charts to be discussed below. Positions of the instruments relative to the manikin are seen in figure 2 (photo taken just prior to exposure). In this figure the second manikin, seen clothed in a typical flight attendant's uniform without a protective garment, was included for estimating the effect of the fire exposure on a typical uniform and fabrics.

R E S U L T S A N D D I S C U S S I O N

Preliminary fires were conducted to ascertain the amount of fuel required to meet the temperature, radiation and exposure time requirements specified in the contract (table I). Several experiments were conducted in the open and it

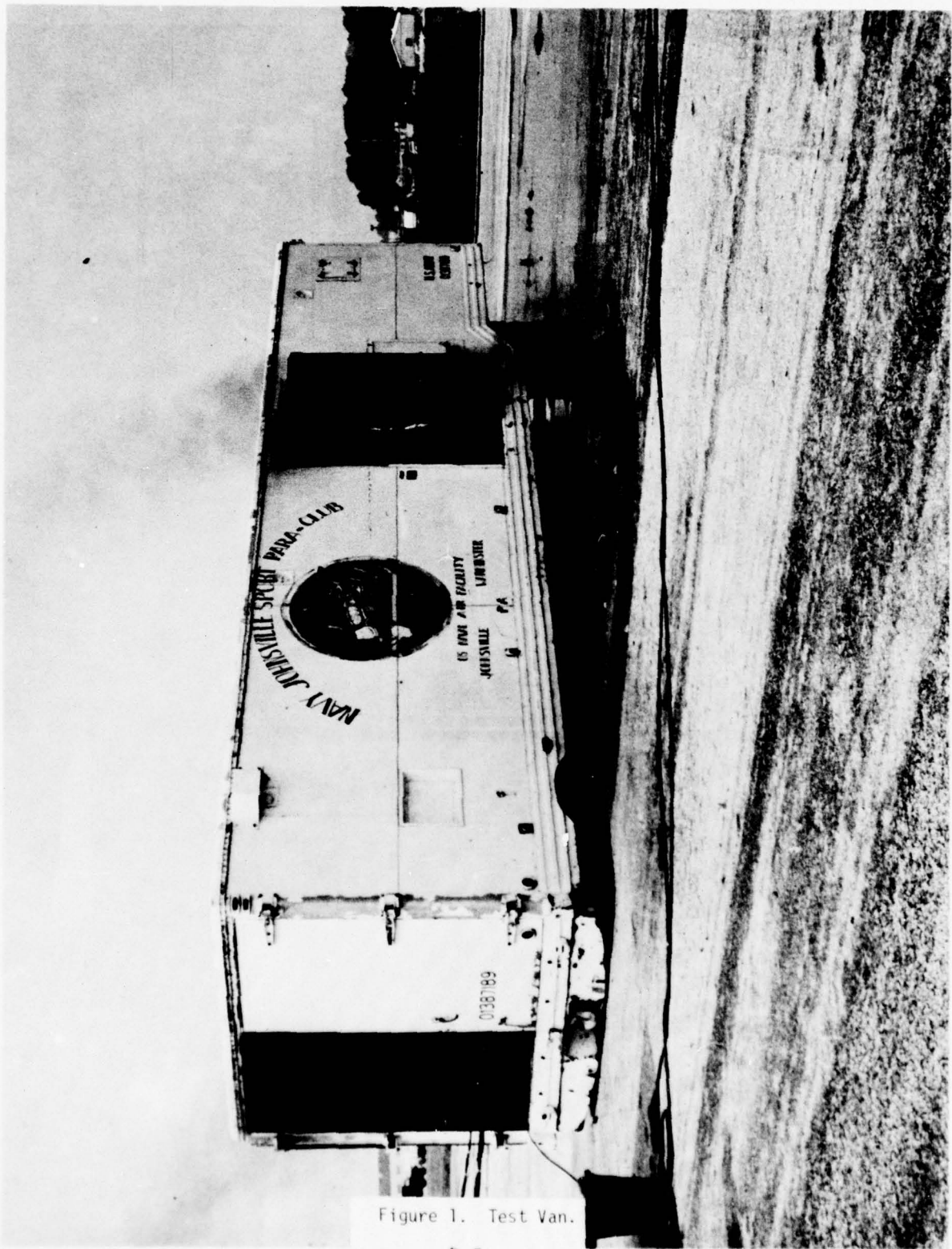

Figure 1. Test Van.

B-5

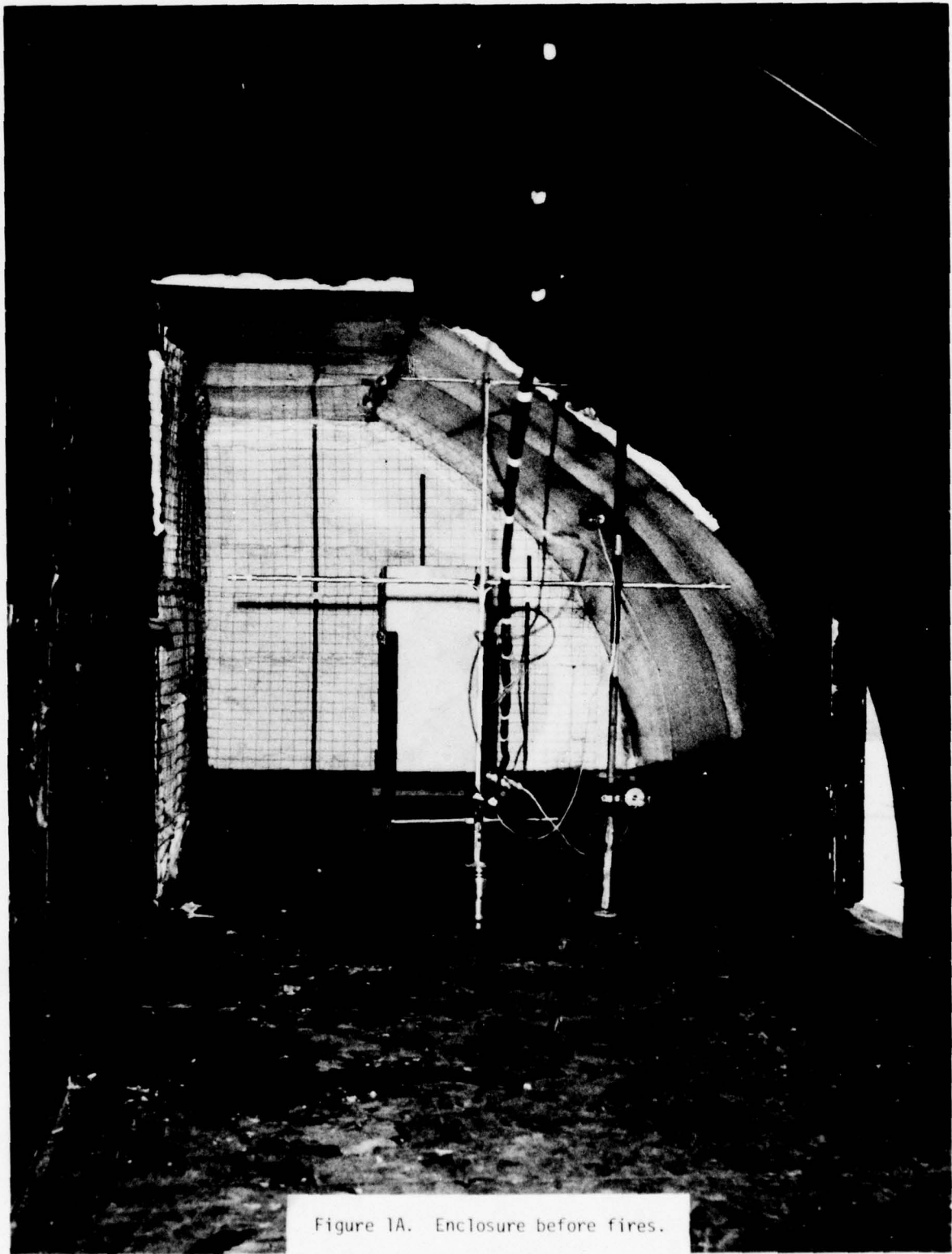

Figure 1A. Enclosure before fires.

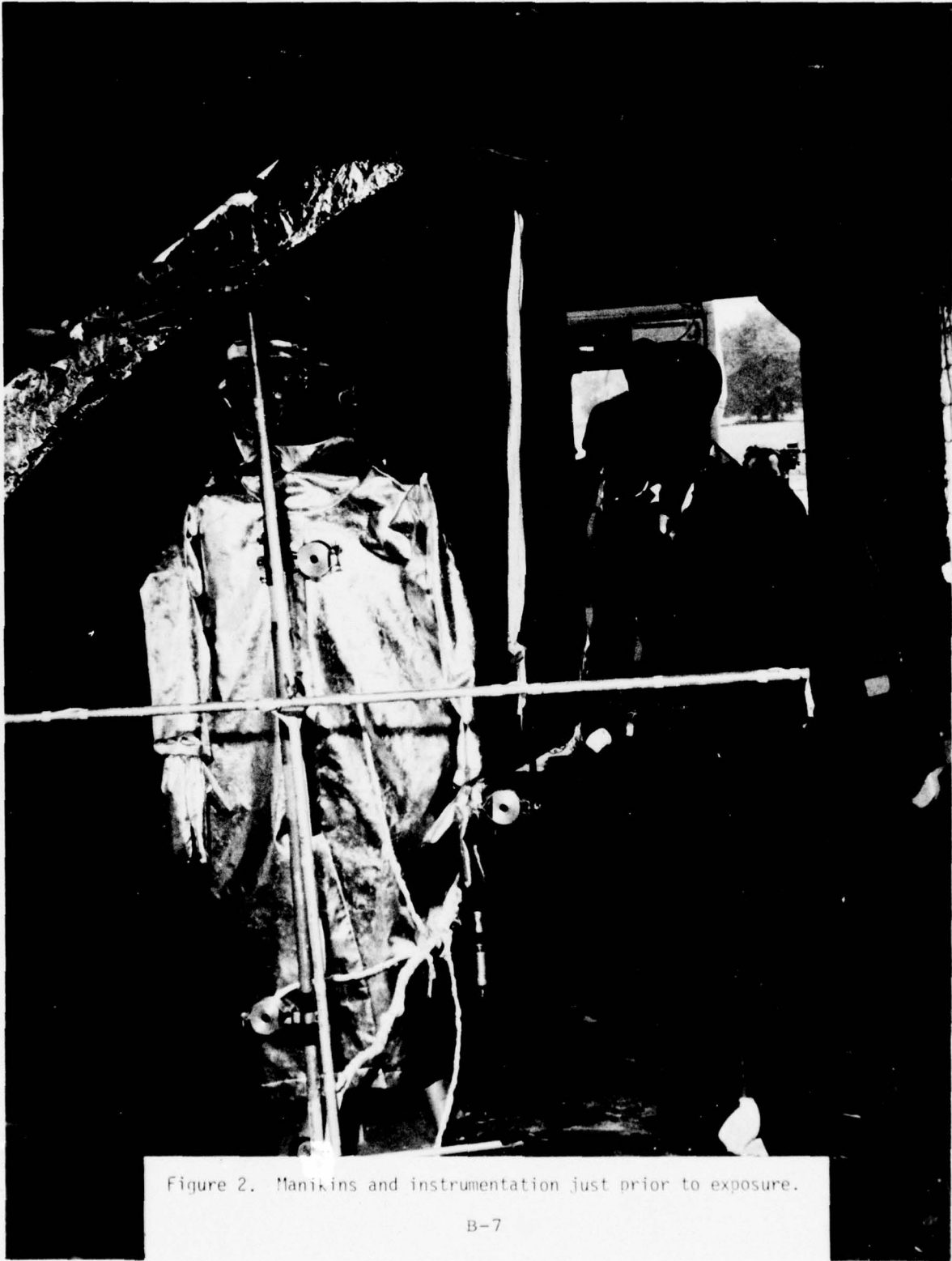

Figure 2. Manikins and instrumentation just prior to exposure.

B-7

T A B L E I
COMPARISON OF EXPERIMENTAL DATA AND CONTRACT PARAMETERS

Time After Ignition sec	Approx. Temp. At Head Level		Estimated Temp. At Knee Level		At Manikin Surface Cal/ cm ² sec	Approx. Heat Flux At Fire Front Btu ft ² sec	Contract ft ² sec
	Experimental OC	Contract OF	Experimental OC	Contract OF			
0	35	95	35	95	0	0	0
60	646	1195	87	189	0.31	1.15	0.96
120-300	445-165	833-329	135-82	275-180	0.15-0	0.55-0	0.6-0.1
							2.2-0.4
							0.4-1.9

B
1
∞

T A B L E I A

TABLE I DATA REARRANGED WITH RESPECT TO TIME

120 sec Duration	685-285	1265-545	650-1250	100-135	212-275	200-300	0.08-0.31	0.3-1.1	0.35-0.96	1.3-3.6	0.4-1.9
------------------	---------	----------	----------	---------	---------	---------	-----------	---------	-----------	---------	---------

was determined that a fire load of about 4 slabs would be sufficient for the purpose. A preliminary run was then made inside the van (without the manikin) using 4 slabs of the foam material. The significant data from this run are shown in figures 3 and 4. Although the radiation intensity and the air temperature peaks fell somewhat short of the contract requirements, the total energy of the exposure scenario was about the same. However, it was decided that for the definitive experiment with the prototype garment, a five slab load of foam would be burned even though the resultant fire might exceed the thermal limits of the van.

Because of the paucity of any experimental data strictly pertinent to the postulated situation, in drawing up the heat load vs time specifications, NASA data collected in closed cabin fires were used (reference 1 and supporting data) as a baseline. It was recognized, however, that during an emergency evacuation, all available exit doors would be open in order for the passengers to exit the aircraft. To simulate the resultant ventilation, the present evaluation was made with the van's side door and half the large end door open. Under these conditions a realistic exposure was made, conforming as closely as possible to the contract specification at the same time.

The instrumented manikin was dressed in female flight attendant's clothing (skirt, blouse, jacket, hose, shoes and underwear) worn under the prototype protective garment. The second manikin was similarly dressed except that slacks replaced the skirt and no protective garment was provided. Placement of all instruments and the two manikins is shown in figures 2, 5 and 6.

Five slabs of foam were used, ignition marked zero time at which point the overgarment's integral air system (within the hood) was activated and instrumentation records started; burning continued through the five minute experimental period during which time the roof of the van was cooled externally by spraying water on it with a fire hose to prevent collapse and loss of the experiment; smoking was not excessive so that the fire was visible throughout the experimental period as the smoke tended to accumulate within a foot or two of the ceiling and poured out of the top of the open doors (figure 7); residual fire was extinguished with a CO₂ extinguisher a few minutes after the experimental period ended. Moving pictures of the fire and inside of the container were taken at 24 frames/sec. throughout the experimental period with additional movies before and after the fire. Still photos were taken of the experimental setup, manikins, etc., as appropriate.

Following the test, the van was permitted to air out for about one hour before anyone entered it. cursory examination of the overgarment immediately after entry revealed light deposits of soot on the hood but no visible changes otherwise (figures 8 and 9). Subsequent detailed examination showed that the fabric system of the hood had been brittlized and physically degraded by the fire exposure. Since this failure did not occur in lower areas of the garment, the breakdown is attributed to high air temperatures and possible increased absorption of radiant heat reflected from the ceiling or reradiated by soot-covered surfaces. Examination of the uniform ensemble on the unprotected manikin showed melting and shrinkage of the jacket fabric in the regions of the left upper chest and shoulder, lapels and collars; the collar and the lapels of the blouse were scorched and shrunken. The left front lower corner of the jacket also shrank. No other damage was visible (figure 10).

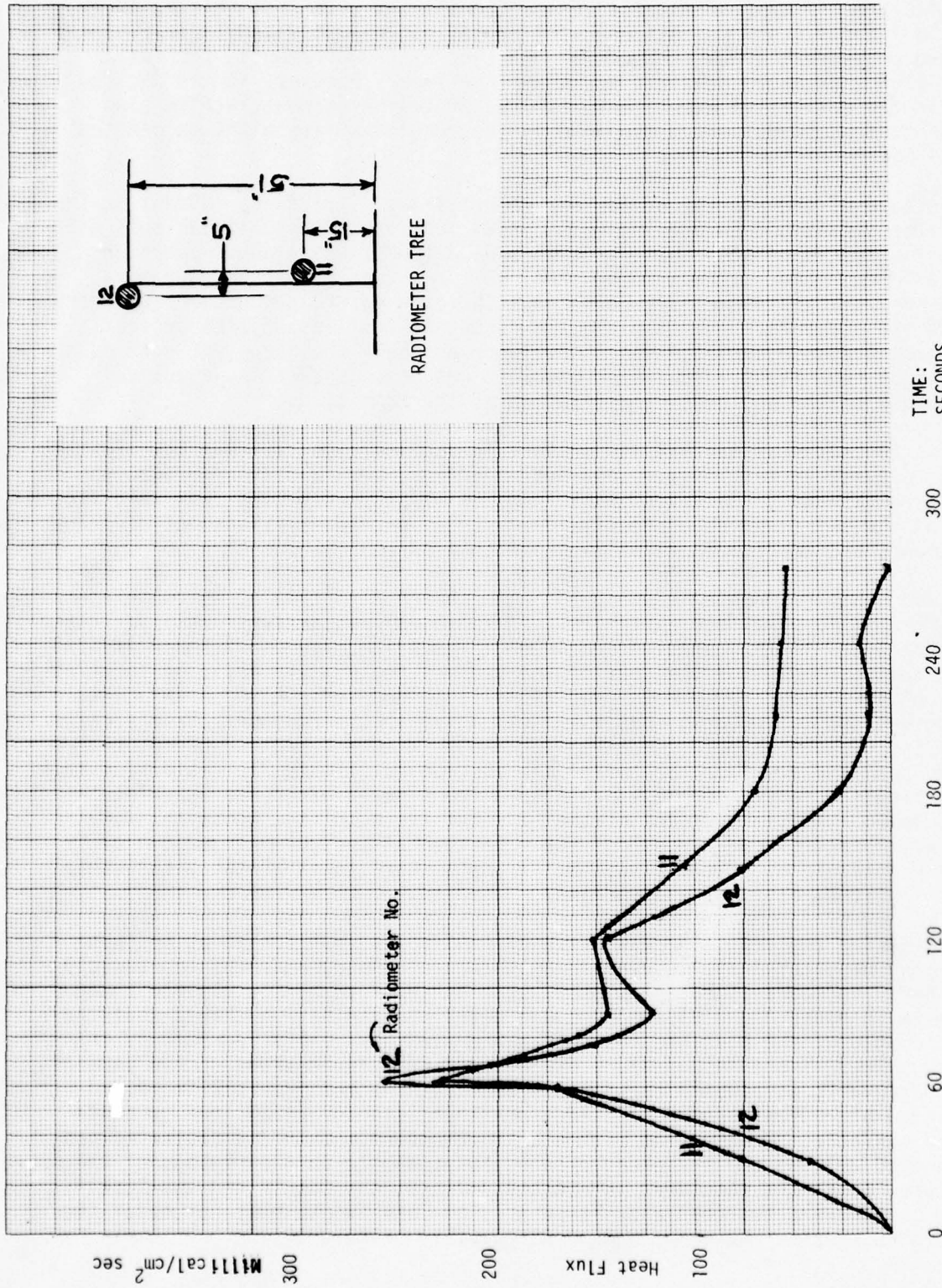

Figure 3. Radiation data preliminary run-(4 Slab Fire Load)

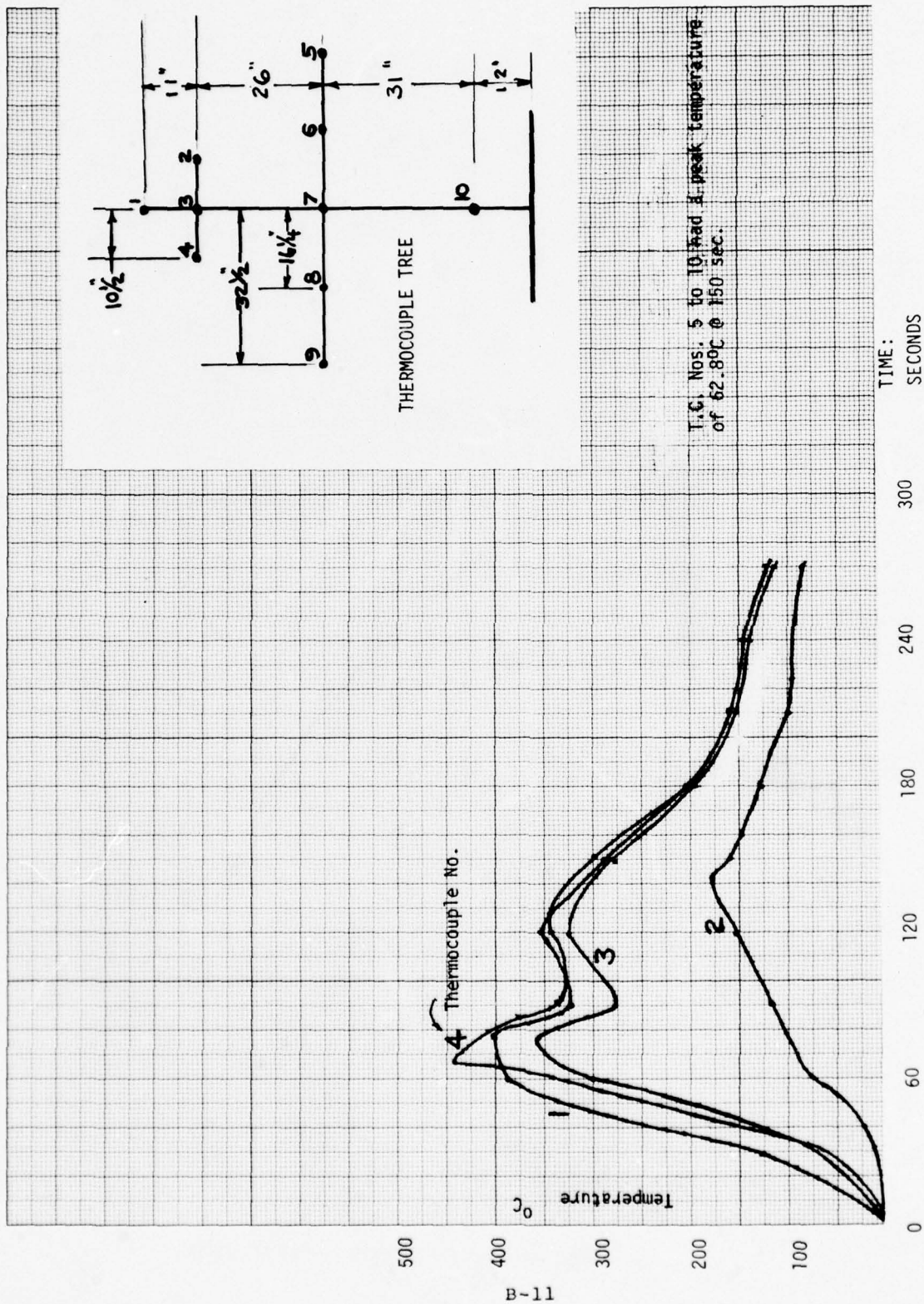
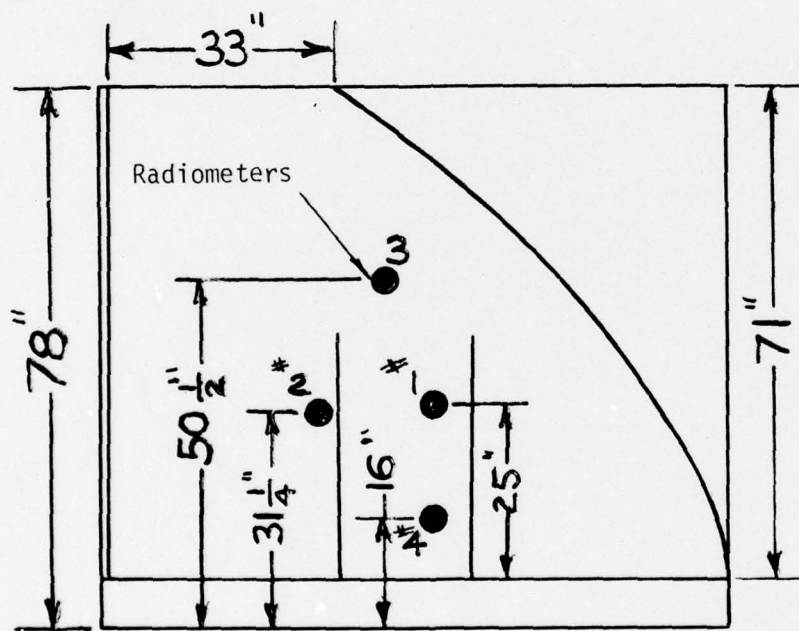
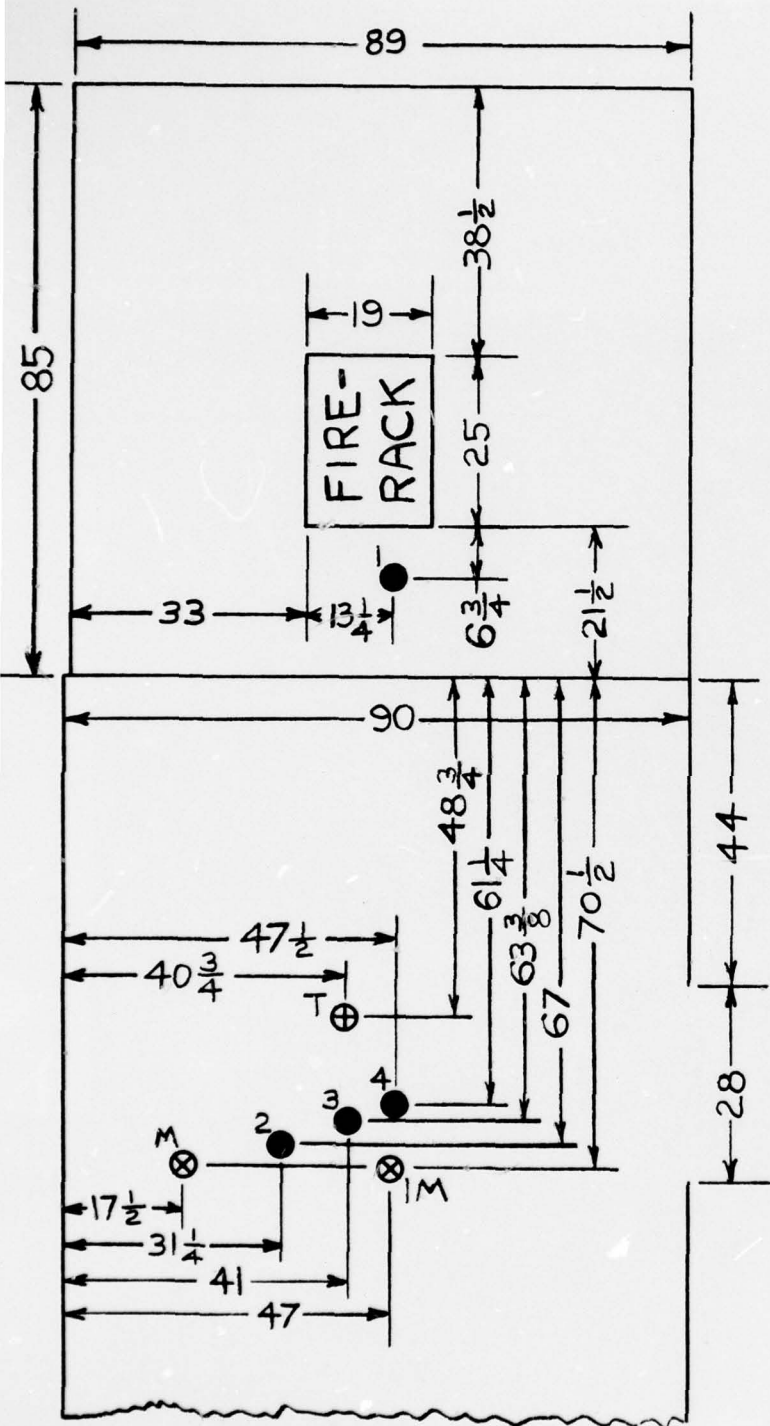

Figure 4. Air temperature data preliminary run-(4 Slab Fire Load)



Refer Figure 1A

Figure 5. Radiometer Locations - Front View



Dimensions in inches.

LEGEND
 Radiometer Nos. 1-2-3-4
 T - Thermocouple Tree
 M - Manikin
 IM - Instrumented Manikin

Figure 6. Location of manikins and instrumentation - Top view.

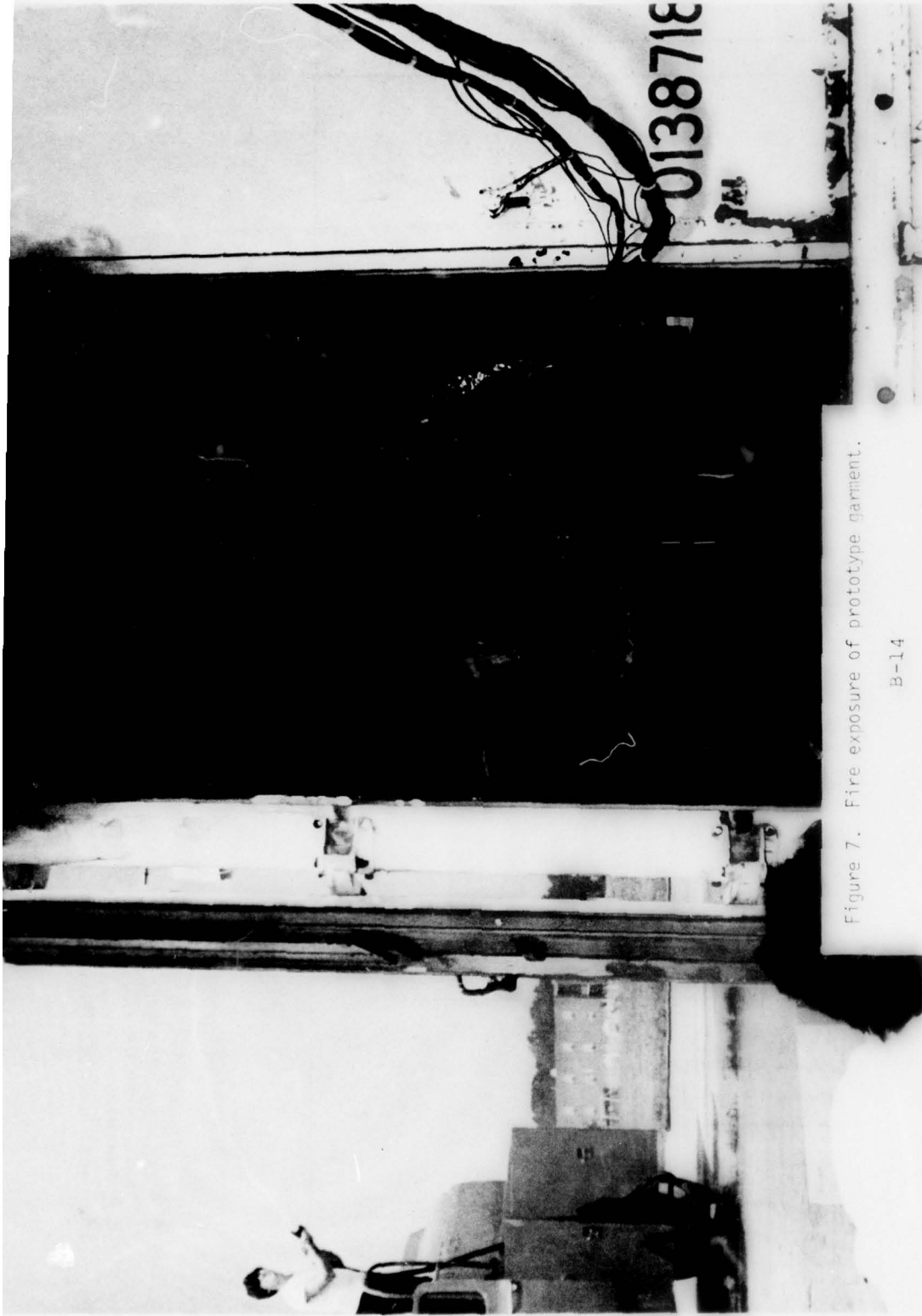

Figure 7. Fire exposure of prototype garment.

B-14

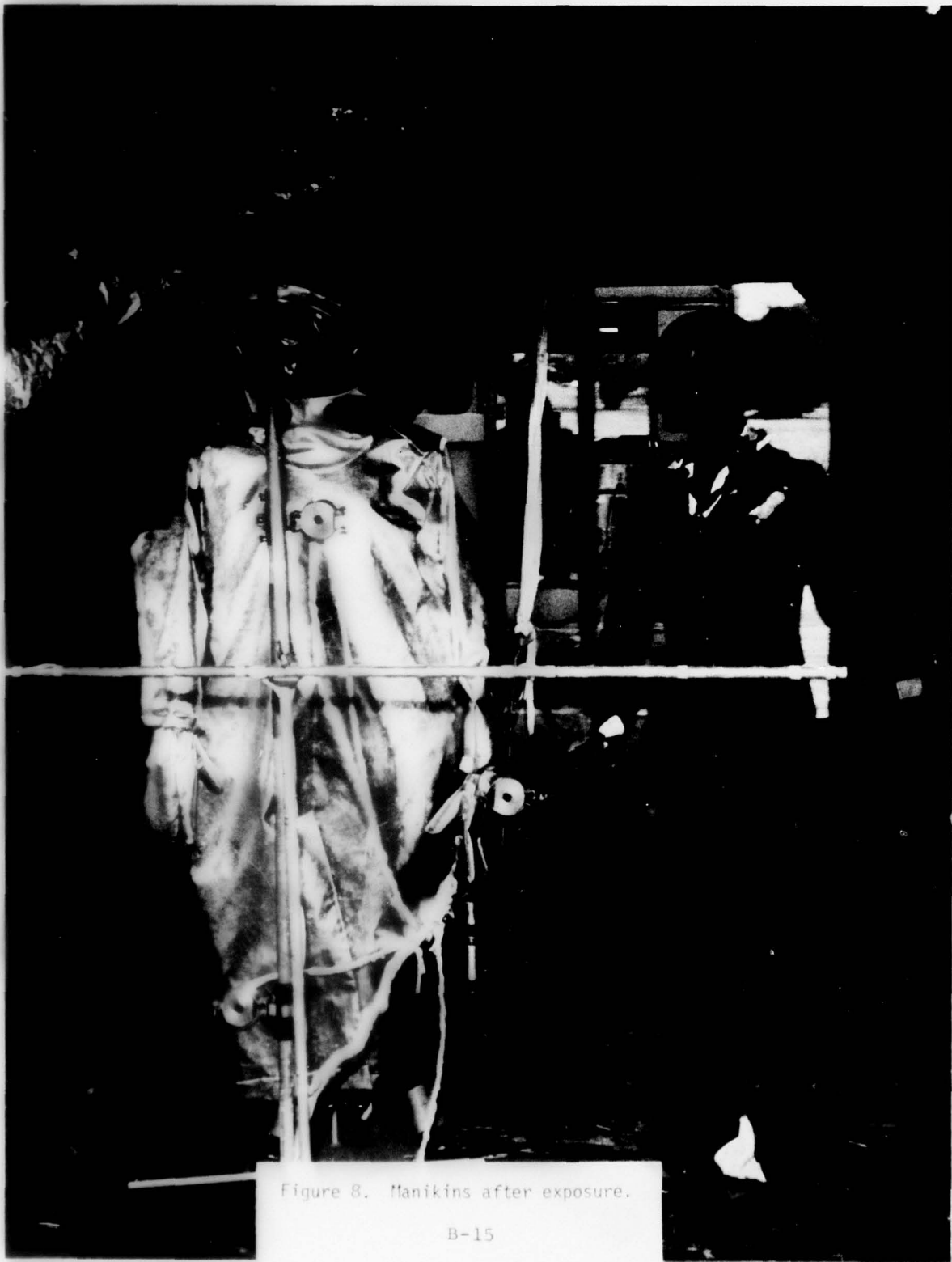

Figure 8. Manikins after exposure.

B-15



Figure 9. Close-up of soot deposit on hood.

B-16



Figure 10. Close-up of damage to unprotected ensemble.

B-17

The comparison of temperatures and radiation flux achieved and those specified in the contract is shown in table I. The contract requires that the manikin wearing the overgarment will be not closer than six feet to a fire source. Radiometer No. 3, approximately at head level, was placed seven feet from the source and eight inches in front of the instrumented manikin and provided the head level data. Radiometer No. 1 was placed approximately seven inches in front of the first foam slab and measured approximately maximum output of the fire.

It is apparent that the contract-specified heat pulses could not be precisely duplicated in this test. However, examination of the total data (tables II, III, IV and figures 11 thru 26) shows that the discrepancies are mainly due to timing and rate of combustion of this fire load rather than failure to achieve sufficiently high air temperatures and radiant flux. For instance, in figure 11 (and table II) note that the maximum air temperature (thermocouple No. 1) near the ceiling was 685°C (1265°F) at 60 sec., dropping to 445°C (831°F) at 120 sec. and 285°C (545°F) at 180-210 sec.; therefore, for a total of about 2.5 minutes the temperature range was 545° to 1265°F. These temperatures are a good approximation of the contract range of 650° to 1250°F although they prevailed between 0.5 and 2.5 minutes of the exposure and are falling rather than rising. Similarly, the radiant flux (table IV, figures 15 through 18) attained significant levels at approximately the same time: near the fire (figure 15), 0.3 cal/cm² sec (1.1 Btu/ft² sec) at 62 sec., peaking at 0.96 cal/cm² sec (3.5 Btu/ft² sec) at 74 sec. and dropping back to 0.3 cal/cm² sec. at 188 sec.; at the manikin surface near the head (figure 17), 0.07 cal/cm² sec. (0.3 Btu/ft² sec.) at 90 sec. and 0.25 (0.9 Btu/ft² sec) at 60 sec., dropping back to 0.07 cal/cm² sec. at 150 sec.

To assess the significance of the radiant flux level on injury and pain, one may consider that 0.07 cal/cm² sec. (0.3 Btu/ft² sec.) absorbed by the skin will produce a second degree burn in about 35 sec., therefore protection is required at this level and above. At an absorption rate of 0.3 cal/cm² sec. (1.1 Btu/ft² sec.) severe burn will be inflicted in about 5 sec. while severe pain occurs much sooner (2).

Reference to the original NASA data (reference 1 and supporting data) which was used as a guide to the requirements for the present development shows that the high radiant flux prevailed for somewhat less than two minutes in the closed test cabin even in the presence of flashover. In this experiment flashover did not occur, nevertheless, high radiant intensities were sustained for about two minutes. The displacement of peak thermal conditions with respect to time simply reflects a faster combustion rate of the different fire load in a well ventilated enclosure. Since the burn effect on living skin depends upon magnitude of elevation of its temperature and duration of the elevated temperature, the exact time of occurrence is of no importance to the subsequent skin damage. When the data of table I are arranged to reflect the exposure levels irrespective of time of occurrence, but with due consideration for the duration of heat input, the results are shown in table IA; it is clear that the intensities achieved experimentally are in satisfactory agreement with the contract objectives. The discrepancy of the air temperature at head level falling rather than rising with time may be attributed to the inflow of cooler air through the open door but, whether rising or falling, the time-temperatures

T A B L E I I I

AIR TEMPERATURE RISE ABOVE 35°C (95°F)

(°Centigrade vs Time, Minutes)

TC No.	<u>1/2</u>	<u>1</u>	<u>1-1/2</u>	<u>2</u>	<u>2-1/2</u>	<u>3</u>	<u>3-1/2</u>	<u>4</u>	<u>4-1/2</u>	<u>5</u>	Peak at Time
1	297.5	650*	397.8	410.4	285.4	254.5	259.8	176.1	150.8	129.5	650 @60 sec
2	47.6	364.7	284.9	300.3	232.1	202.9	179.3	152.3	135.6	118.4	374.1 @64 sec
3	240.1	594.2	379.4	402.2	282.3	250.7	213.5	173.4	149.4	127.9	610.6 @58 sec
4	262.9	582.5	409.0	383.7	270.9	230.5	214.5	173.2	141.2	124.0	598.0 @63 sec
5	18.2	48.9	44.4	58.2	45.7	36.0	25.9	20.6	22.2	27.1	58.2 @120 sec
6	17.3	49.0	54.0	78.9	52.3	46.4	43.9	40.5	34.6	34.2	79.3 @121 sec
7	17.3	57.9	64.6	84.9	60.6	53.3	53.9	47.6	42.6	36.3	87.2 @117 sec
8	17.2	72.3	82.9	81.8	67.9	62.4	57.3	52.1	43.3	41.5	97.6 @126 sec
9	19.0	82.1	81.0	77.7	71.2	64.6	50.7	52.6	33.9	38.3	89.4 @68 sec
10	11.5	37.0	35.3	25.1	24.1	17.6	13.2	12.2	9.8	9.5	42.7 @64 sec

*Extrapolated

T A B L E I I I
EQUIVALENT SKIN TEMPERATURES*

(°C vs. Time in Minutes)

TC No.	Location/Time	1/2	1	1-1/2	2	2-1/2	3	3-1/2	4	4-1/2	5	9-1/3	Pk at Time
1	Left Forehead	42.5	75.9 off scale										
2	Right Cheek	35.2	44.4 56.5 off scale										
3	Left Cheek	40.9	74.7 off scale										
4	Throat	32.7	33.5 35.1	39.9	44.4	43.7	44.5	45.7	46.7	47.4	52.8	52.8	>560 sec
5	Right Breast (Inside)	32.5	33.4 37.0	40.7	44.0	45.0	45.9	47.2	47.8	48.0	47.2	48.1	@330 sec
6	Left Breast (Outside)	32.5	32.9 36.0	38.9	40.8	40.9	40.7	40.5	40.3	40.1	40.3	41.1	@169 sec
7	Right Bicep	32.6	33.8 37.4	39.5	40.6	40.7	40.7	40.7	40.6	40.4	39.3	40.7	@210 sec
8	Left Bicep	32.5	33.4 38.2	40.9	42.0	42.0	41.9	42.3	42.5	42.6	42.2	42.8	@375 sec
9	Abdomen	32.5	32.5 32.6	32.8	33.1	33.4	33.8	34.2	34.4	34.7	35.9	35.9	>560 sec
10	Right Forearm	32.6	33.7 37.6	39.8	40.8	41.3	41.6	41.8	42.1	42.1	41.7	42.1	@300 sec
11	Left Forearm	32.7	35.2 41.5	44.9	47.1	48.3	49.0	49.4	49.3	49.0	46.1	49.4	@255 sec
12	Right Hip	32.5	32.5 32.8	33.3	33.9	34.5	34.8	35.1	35.4	35.6	36.8	36.8	>560 sec
13	Left Hip	32.5	32.4 32.6	32.8	33.2	33.5	33.8	34.0	34.2	34.4	35.2	35.2	>560 sec
14	Right Hand	32.5	32.7 33.9	34.3	34.9	35.2	35.4	35.6	35.8	36.0	36.9	36.9	>560 sec
15	Left Hand	32.7	35.2 40.3	42.6	43.8	44.1	44.1	44.2	44.2	44.0	42.4	44.2	@240 sec
16	Right Thigh (Inside)	32.5	32.5 32.6	32.8	33.1	33.4	33.7	34.0	34.3	34.4	34.9	34.9	>560 sec
17	Left Thigh (Outside)	32.4	32.4 32.6	33.0	33.3	33.9	34.2	34.6	34.9	35.1	36.2	36.2	>560 sec
18	Right Kneecap	32.5	32.9 33.7	34.2	34.6	34.9	35.1	35.7	35.7	35.8	36.3	36.3	>560 sec
19	Left Calf (Outside)	32.5	32.5 32.8	33.1	33.3	33.6	33.9	34.1	34.2	34.4	35.0	35.0	>560 sec
20	Right Shin	32.7	33.5 34.3	34.7	35.0	35.1	35.2	35.6	35.7	35.8	36.0	36.0	>560 sec
21	Right Ankle	32.8	34.6 36.4	37.3	37.5	37.5	37.8	38.1	38.1	37.9	37.4	38.1	@270 sec
22	Left Ankle	32.6	33.6 34.6	35.1	35.4	35.7	36.0	36.6	36.6	36.9	37.2	37.2	>560 sec

*NOTE: Pain threshold: 45°C
Maximum pain: 58°C
Second degree or greater burn: 50°C maintained for 30 sec.

T A B L E I V
 RADIANT FLUX INTENSITIES
 (CaI/cm² sec vs. Time in Minutes)

Radiometer No.	<u>1/2</u>	<u>1</u>	<u>1-1/2</u>	<u>2</u>	<u>2-1/2</u>	<u>3</u>	<u>3-1/2</u>	<u>4</u>	<u>4-1/2</u>	<u>5</u>	<u>Pk at Time</u>
1	.036	.212	.667	.605	.417	.345	.267	.186	.134	.110	.964 @74 sec
2	.080	.245	.169	.139	.094	.078	.067	.057	.048	.042	.265 @69 sec
3	.096	.272	.179	.151	.061	.044	.032	.017	.004	.000	.305 @58 sec
4	.107	.219	.183	.139	.095	.086	.077	.062	.058	.055	.240 @64 sec

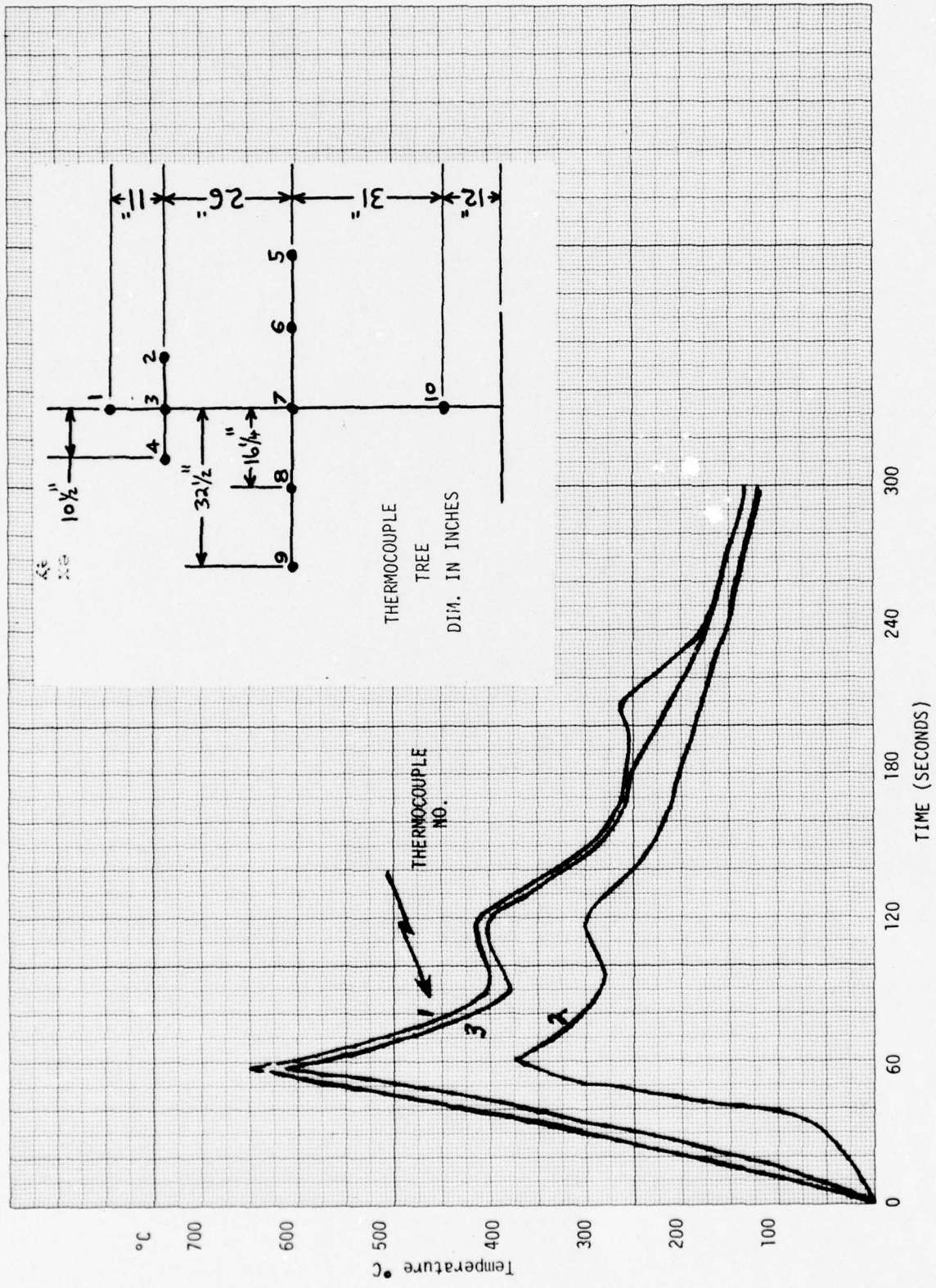

Figure 11. Air Temperatures (above 35°C).

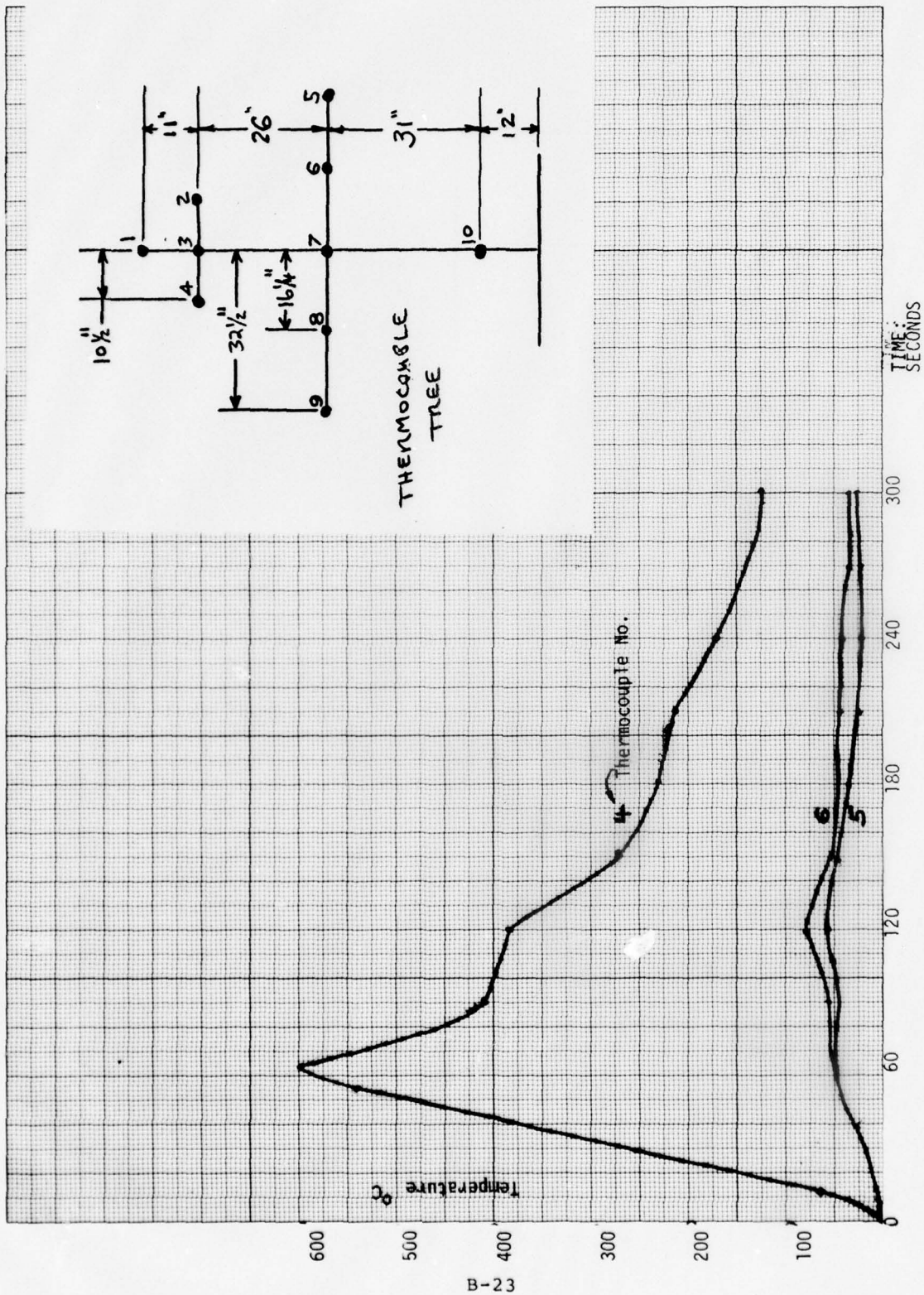

Figure 12. Air Temperatures. (Above 350C)

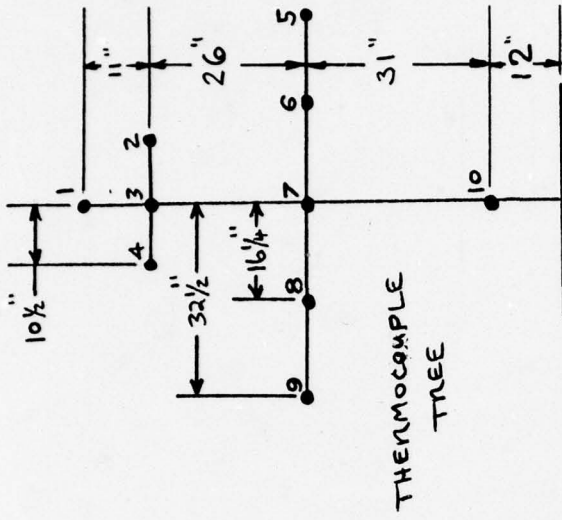
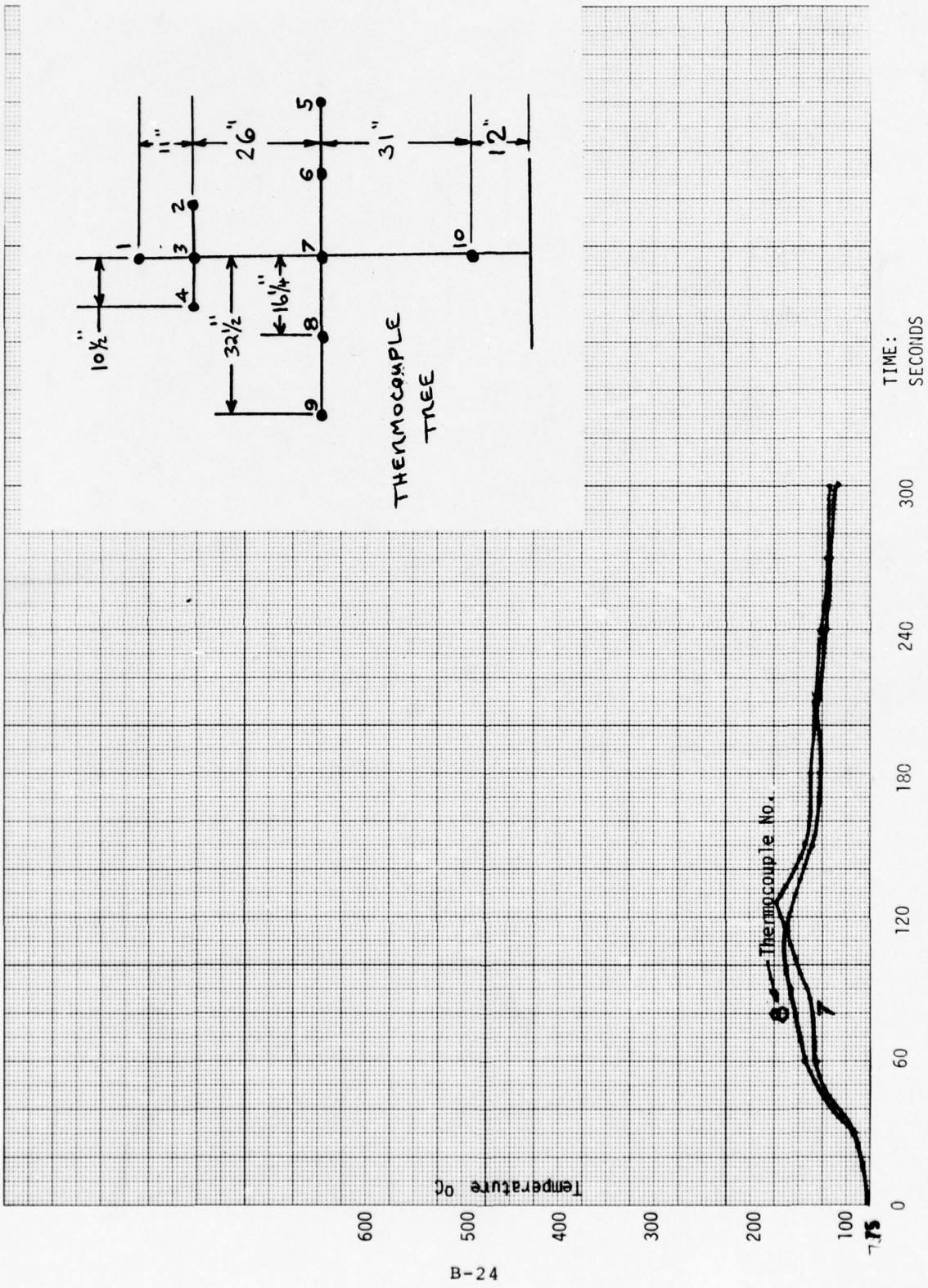
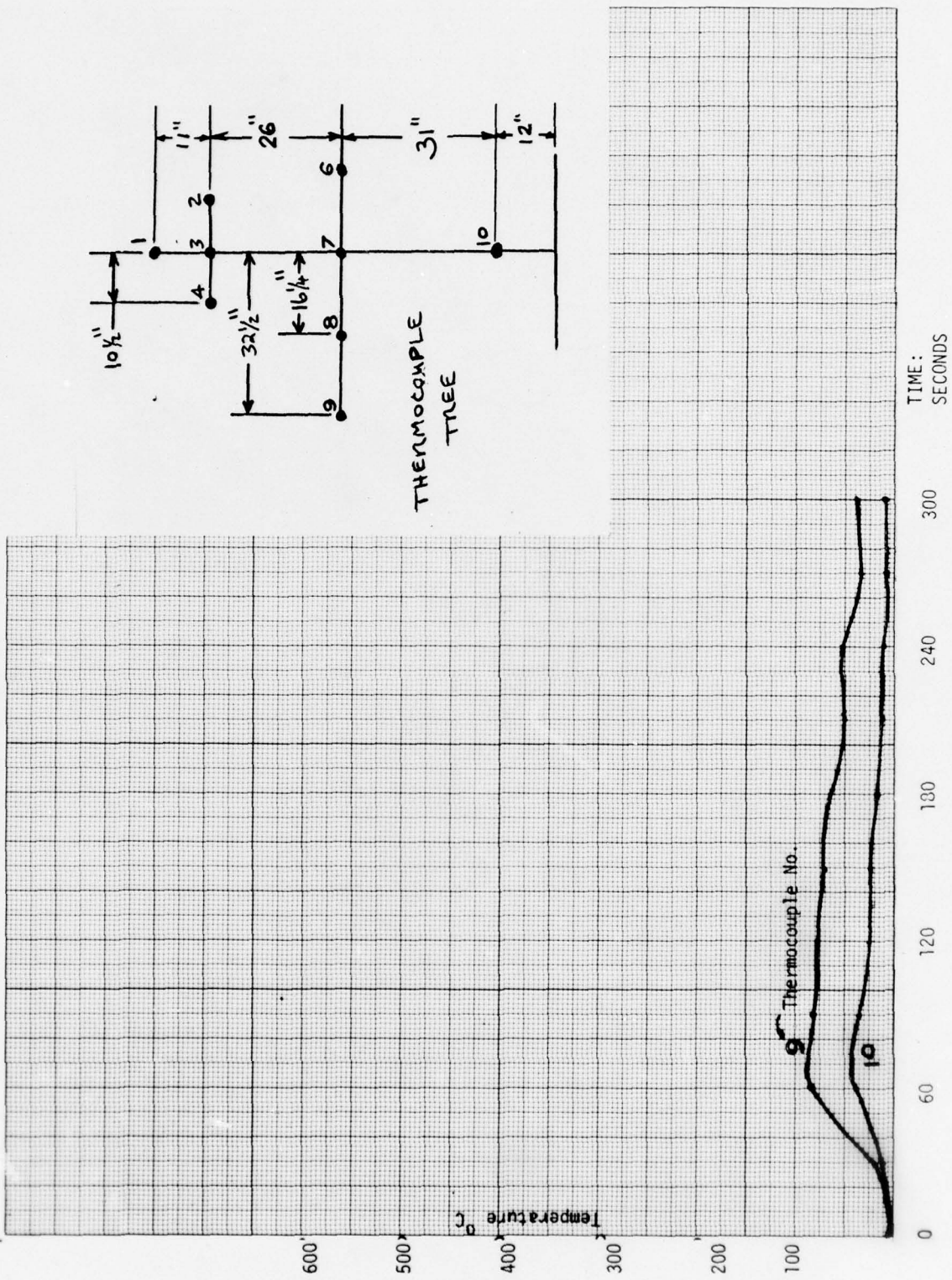

Figure 13. Air Temperatures. (Above 350°C)



B-25

Figure 14. Air Temperatures. (Above 35°C)

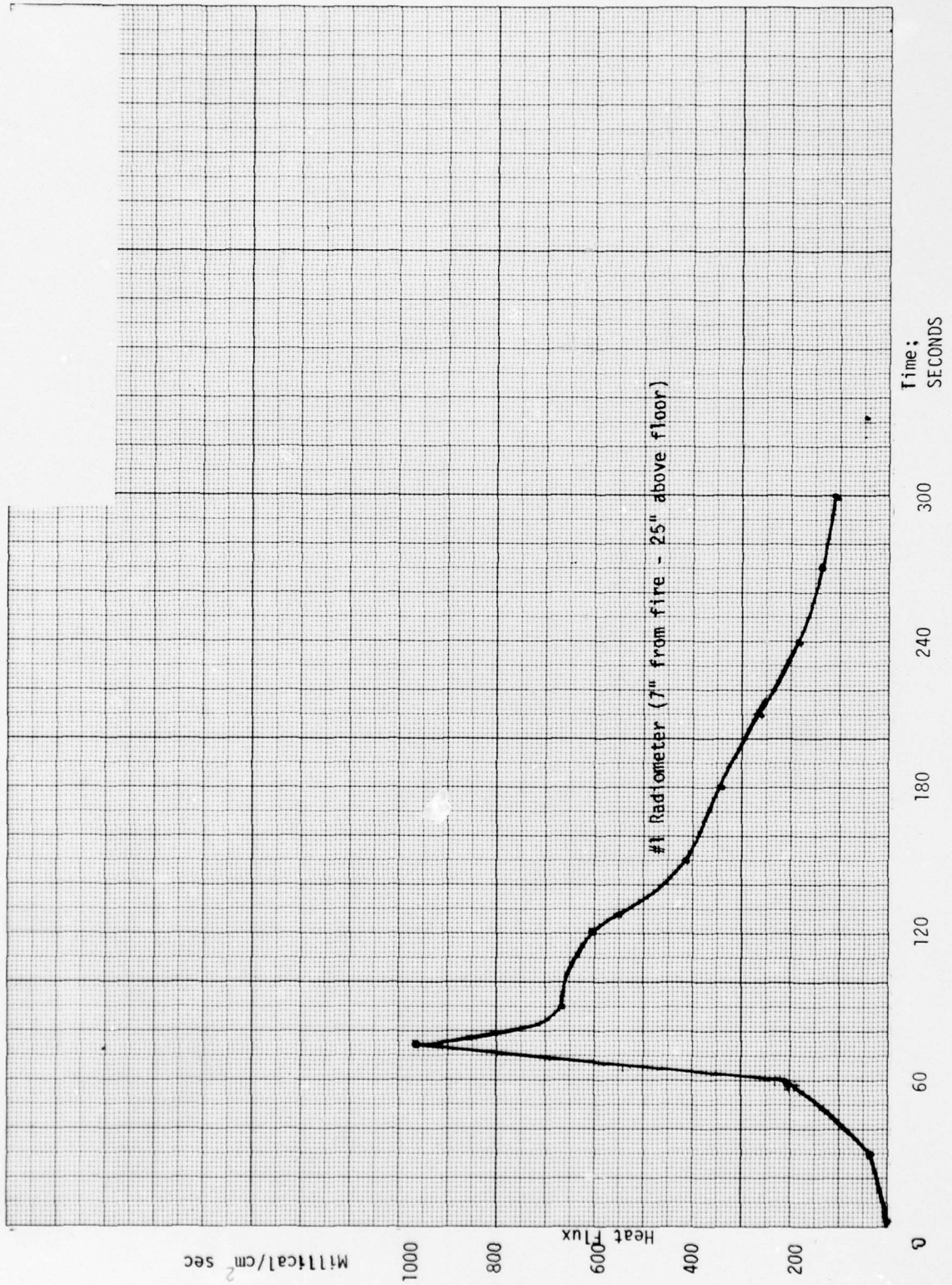

Figure 15. Radiant Flux.

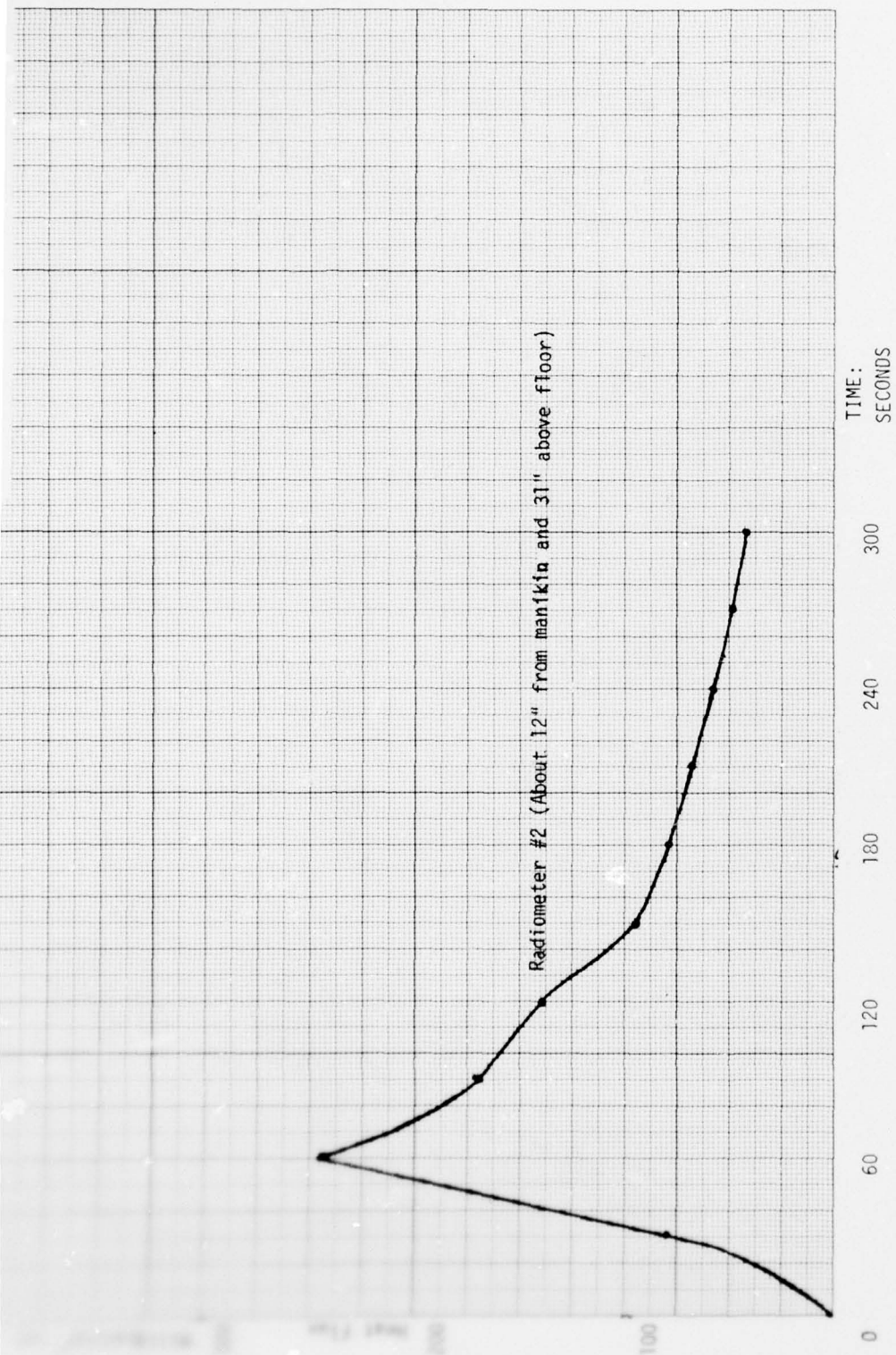

Figure 16. Radiant Flux.

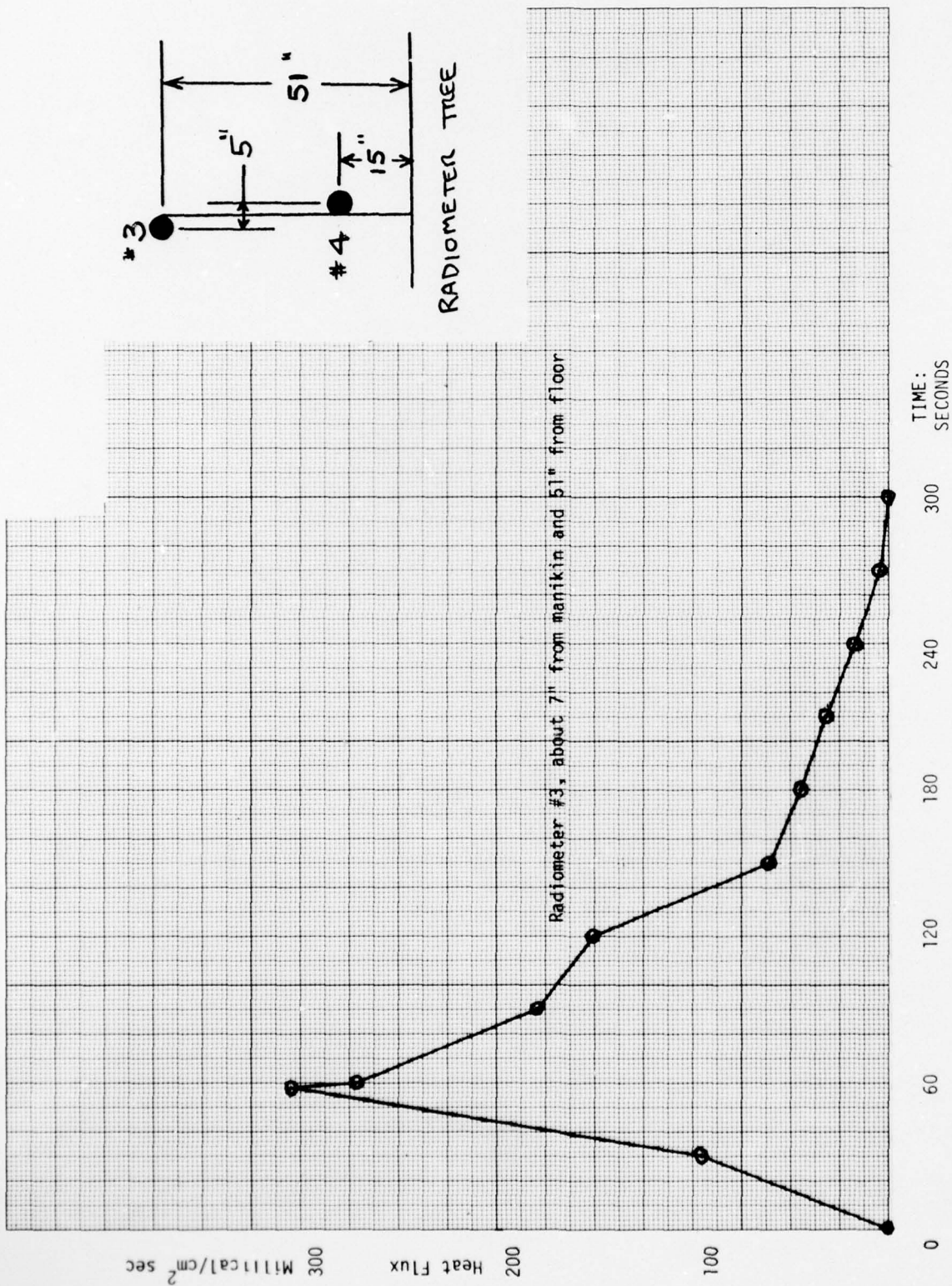
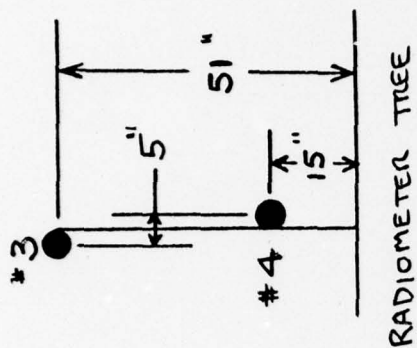

Figure 17. Radiant Flux.



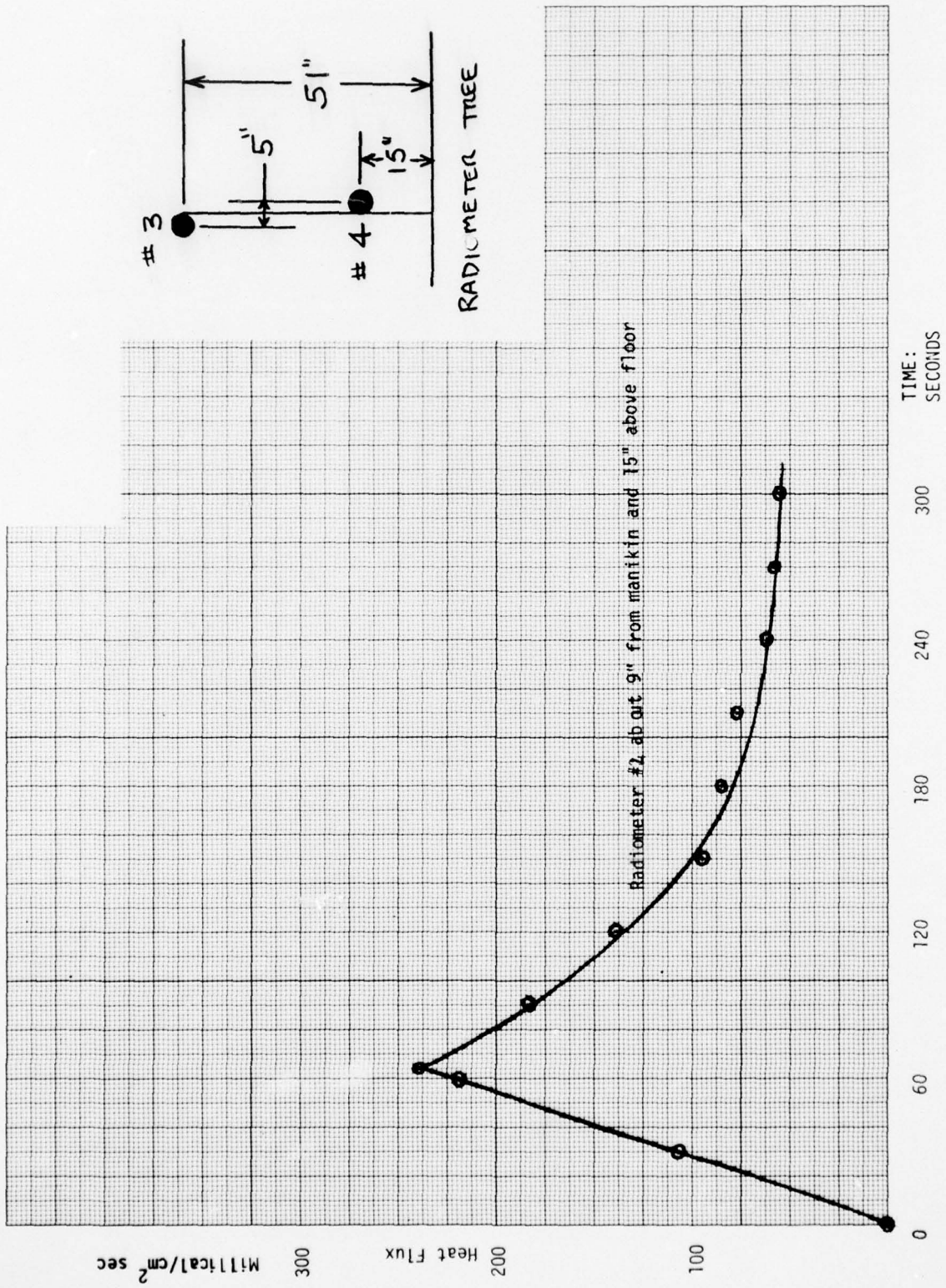

Figure 18. Radiant Flux.

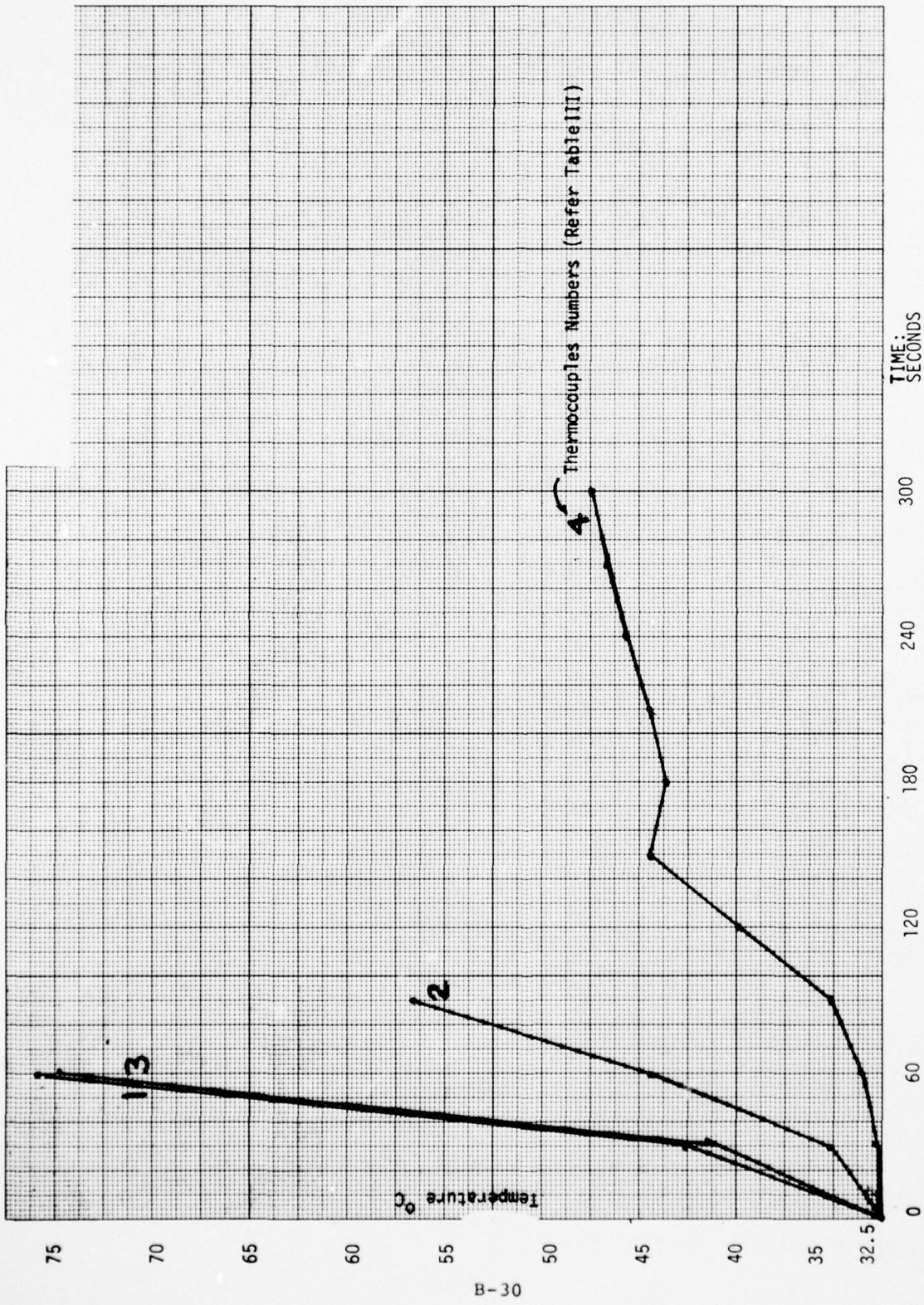

Figure 19. Equivalent Skin Temperatures - Manikin Surface

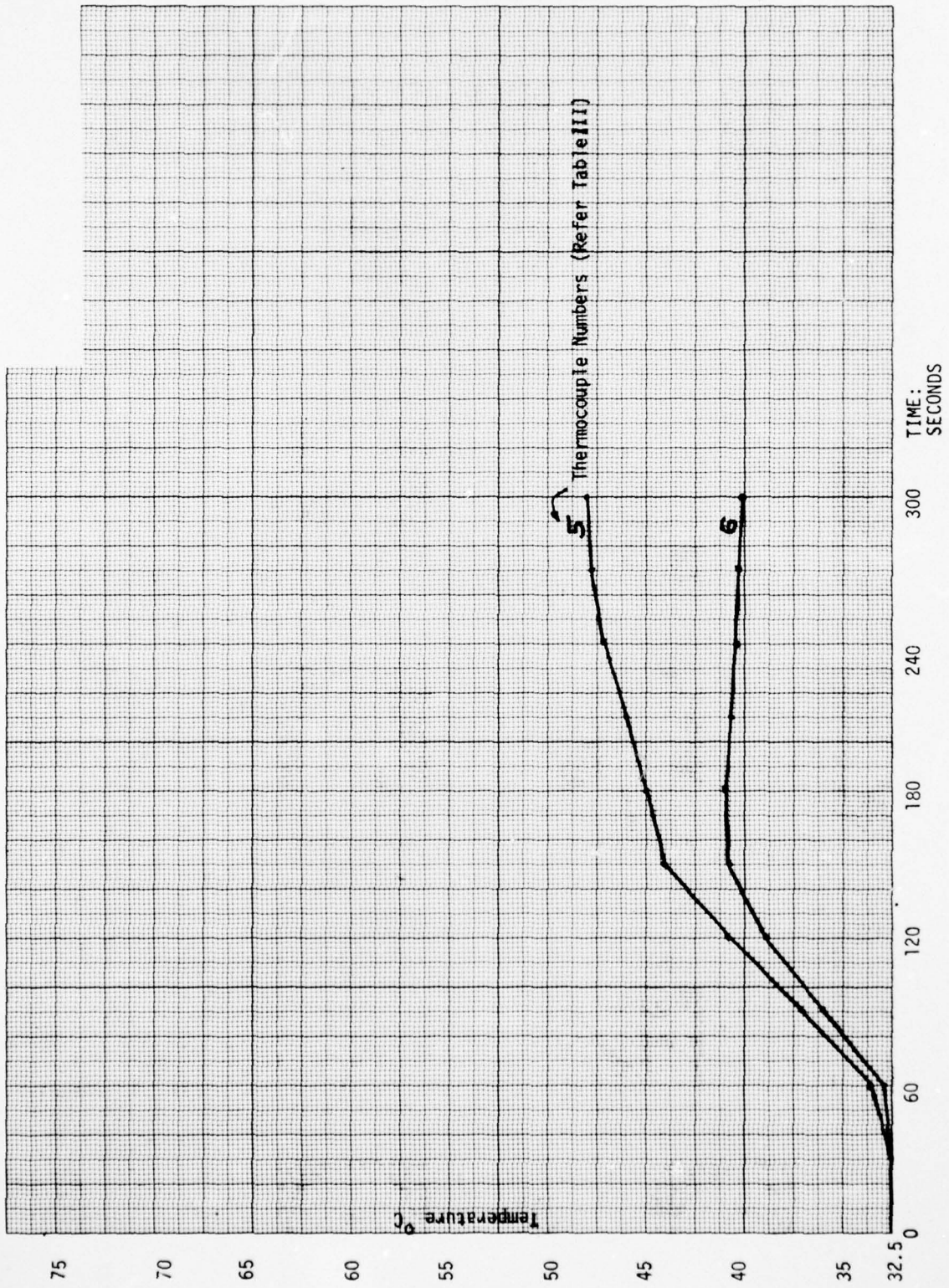

Figure 20. Equivalent Skin Temperatures — Manikin

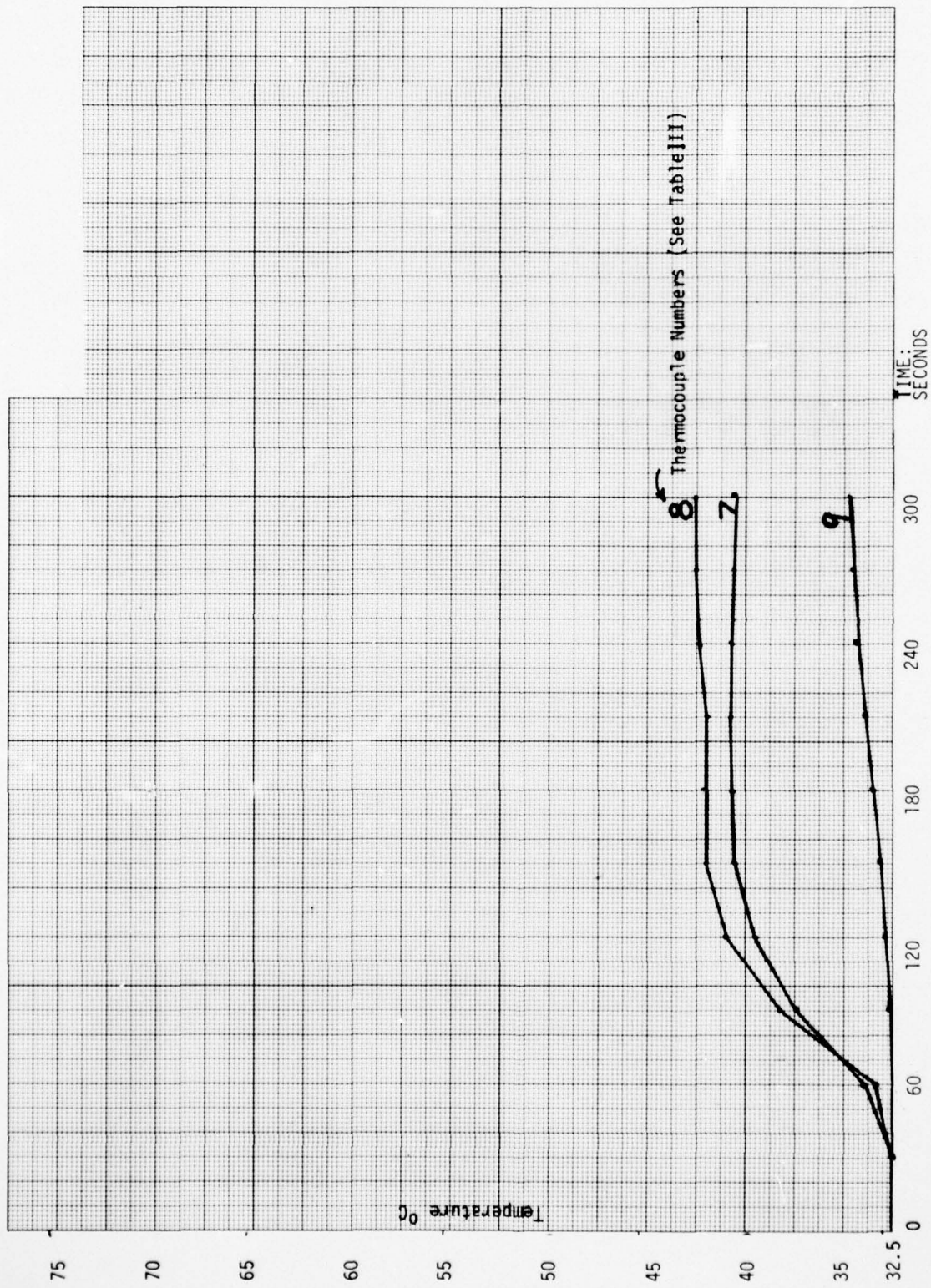

Figure 21. Equivalent Skin Temperatures - Manikin Surface

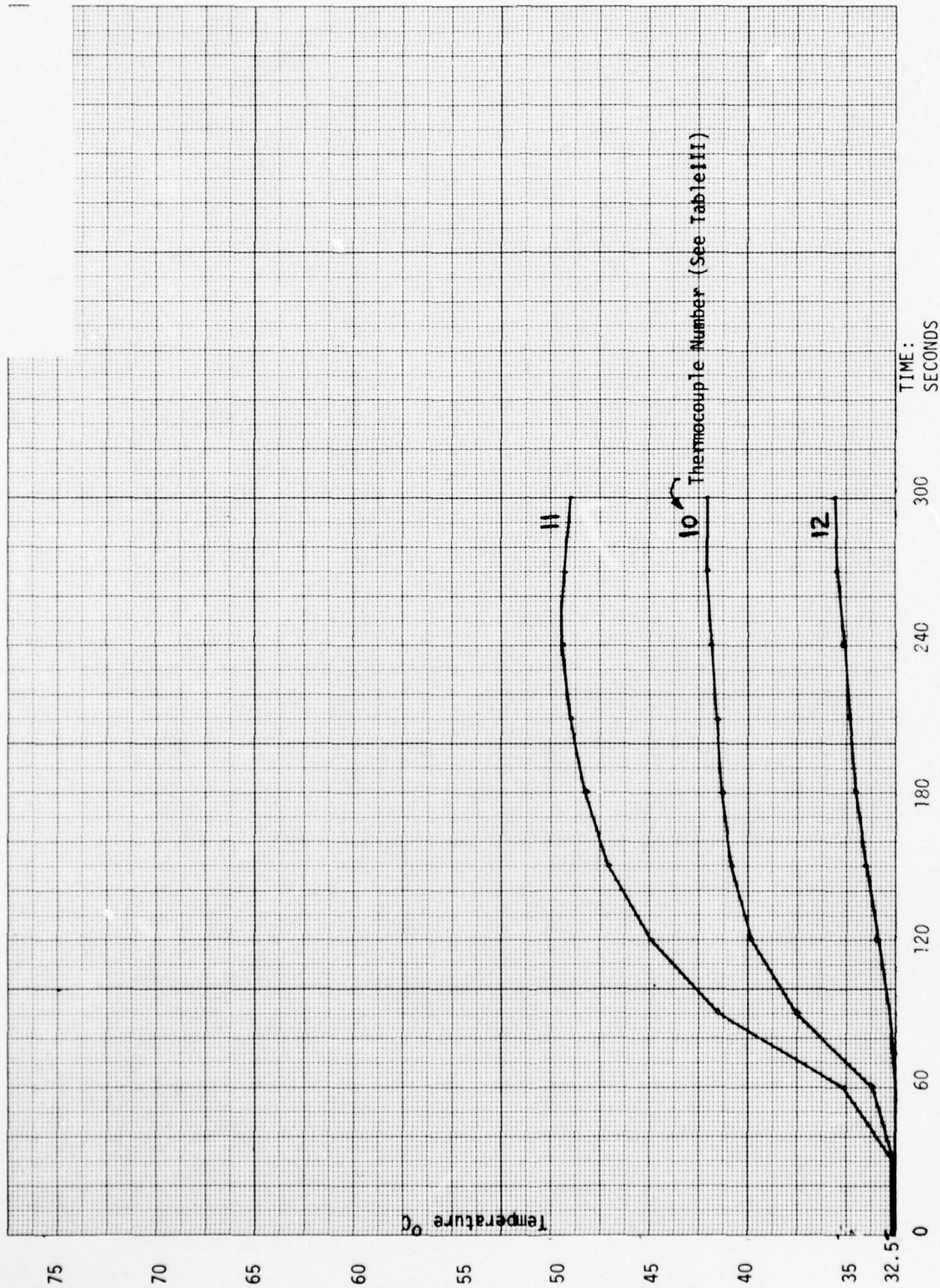

Figure 22. Equivalent Skin Temperatures - Manikin Surface

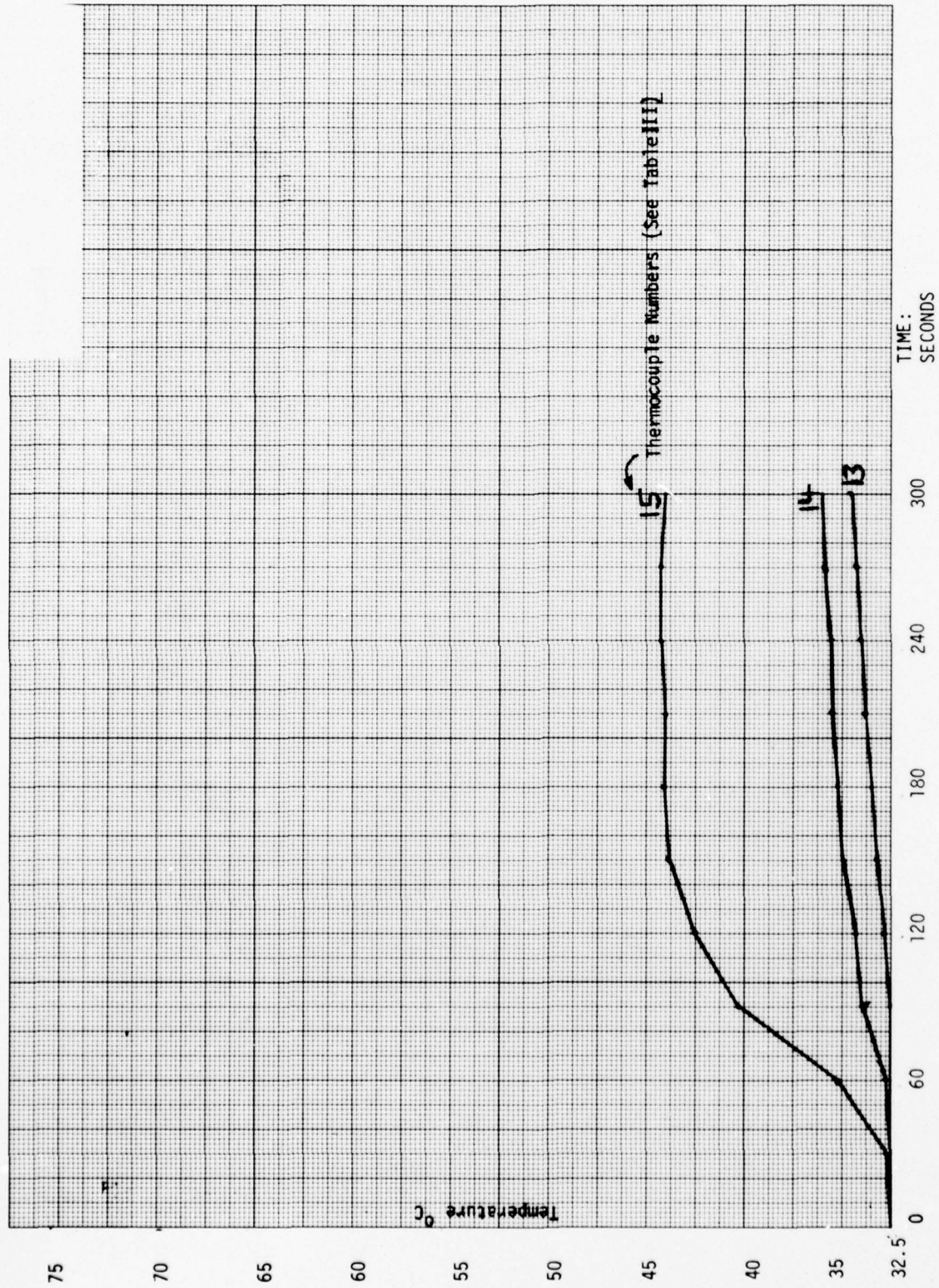

Figure 23. Equivalent Skin Temperatures - Manikin Surface

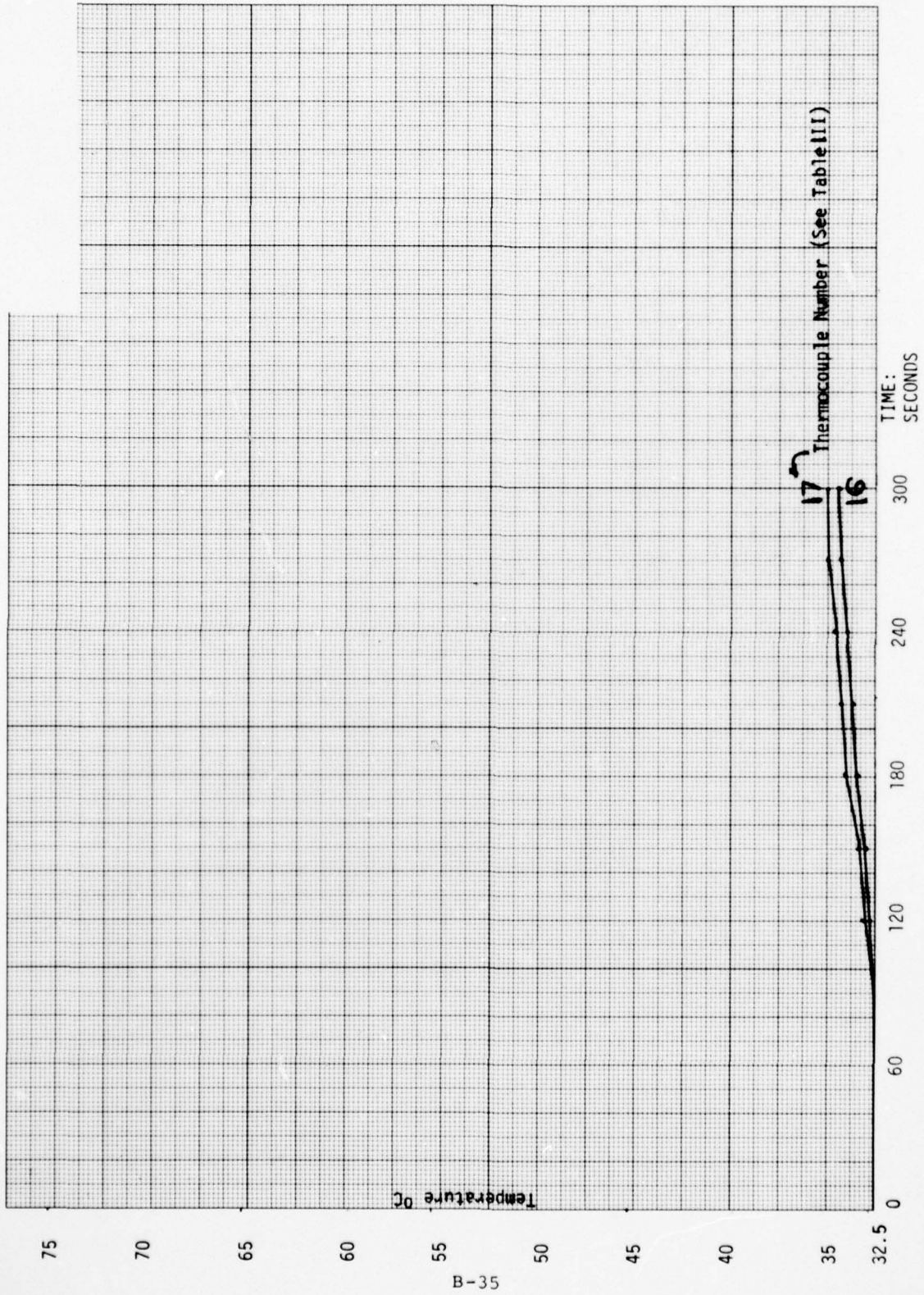

Figure 24. Equivalent Skin Temperatures - Manikin Surface

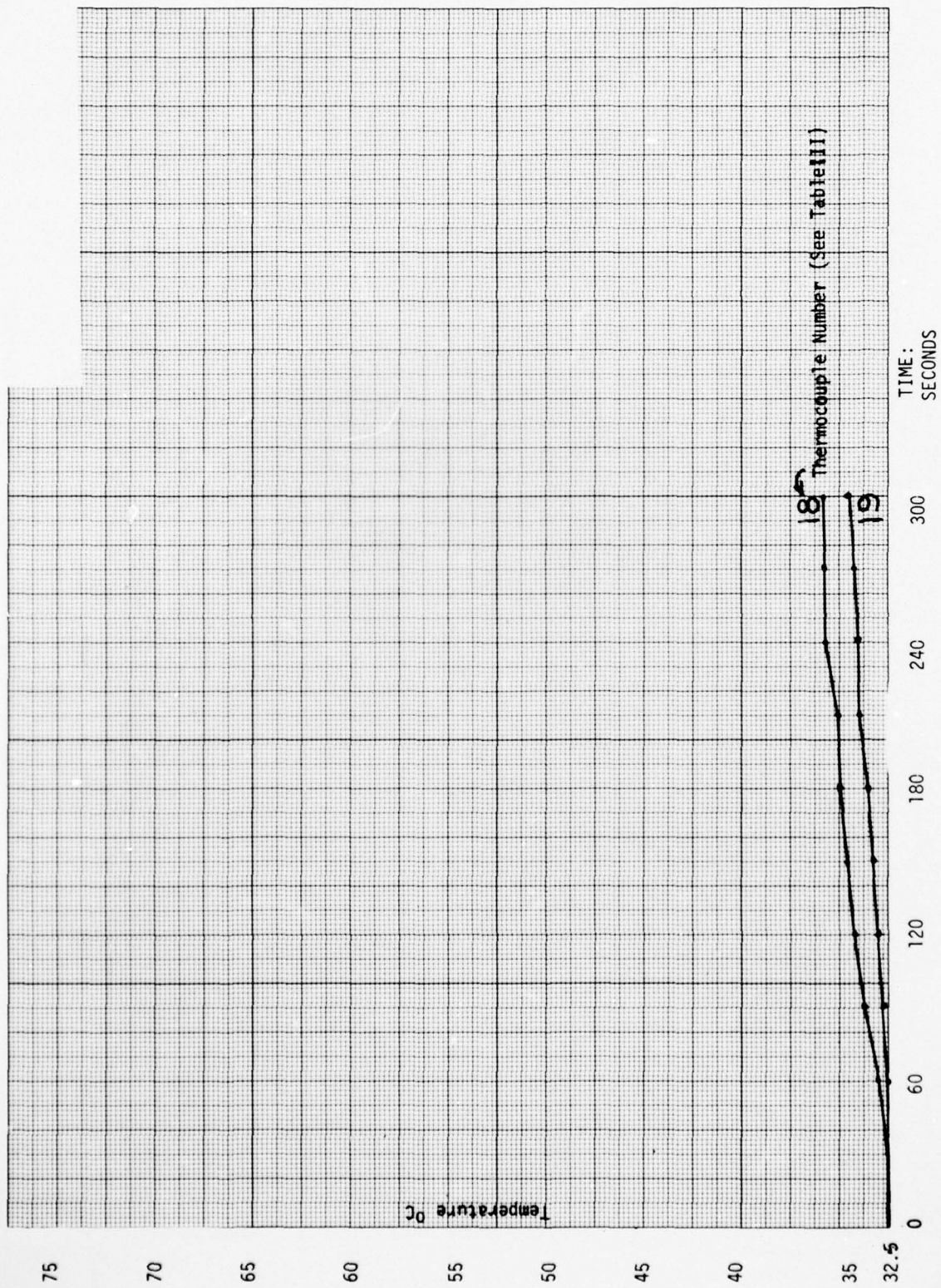

Figure 25. Equivalent Skin Temperatures -Manikin Surface

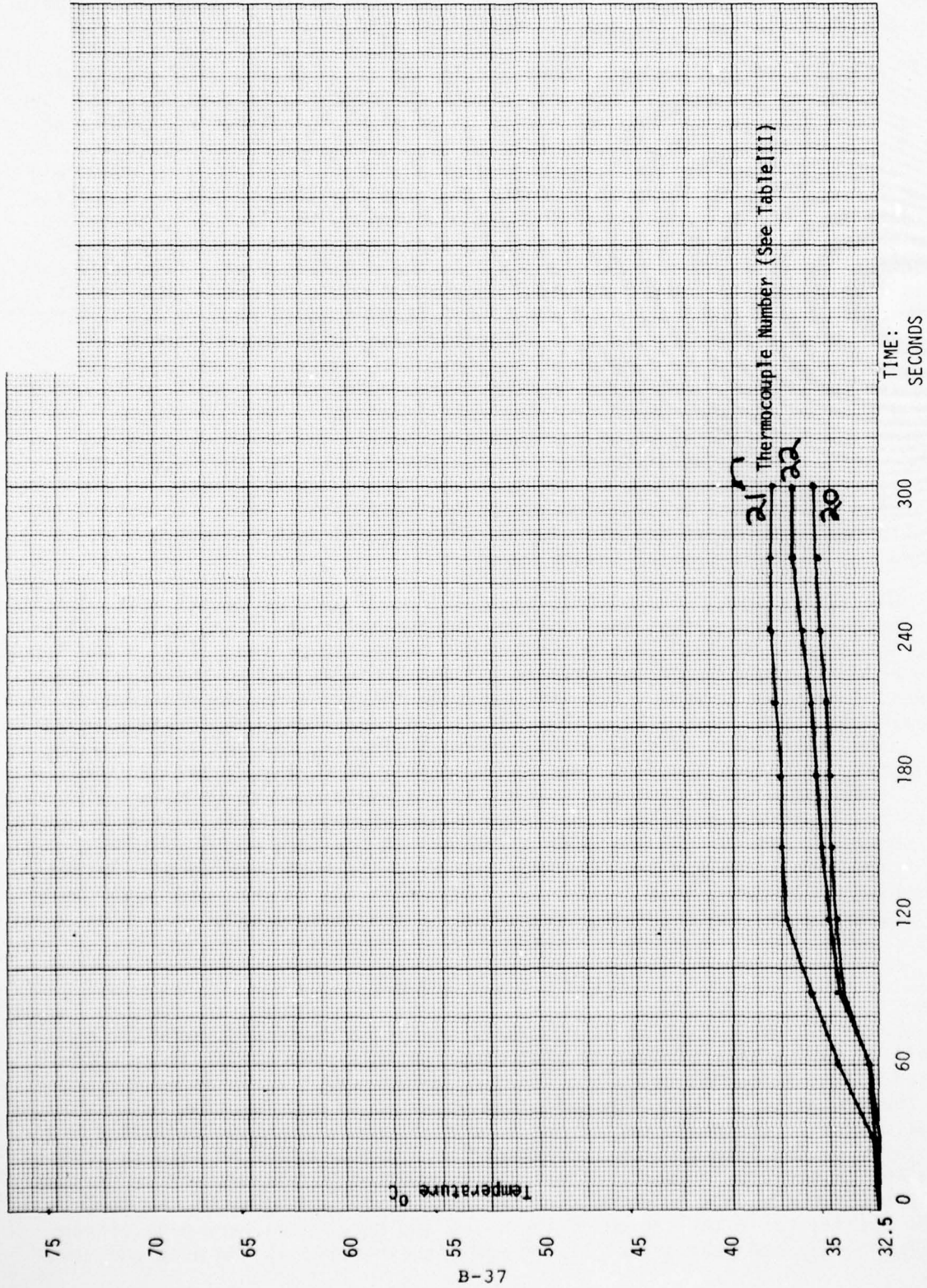

Figure 26. Equivalent Skin Temperatures -Manikin Surface

experienced here are potentially lethal. The important indicator of injury, of course, is the resultant skin temperature under the protective garment. These data are shown in table III and figures 19 thru 26.

Table III identifies each thermocouple and its location with respect to the 22 sites on the manikin surface beneath the clothing (figure 27). The sensor at each site was calibrated in situ on exposure to a known heat flux and the output of the sensor was converted to the equivalent effect known to occur in living skin at an initial temperature of 32.5°C (90.5°F) (2), a reasonable value for normal skin temperature under the same conditions. In interpreting the data in table III consideration must be given to the fact that threshold pain occurs at about 45°C (113°F) skin surface temperature and maximum pain sensation occurs at about 58°C (136°F). In the excitement of a fire emergency it is likely that the normal threshold sensation would be overlooked due to distraction but a temperature of about 50°C (122°F) would produce sufficient pain to override this distraction. Therefore, any skin temperature in the vicinity of 50°C must be considered sufficient to cause a flight attendant to flee the environment; otherwise, second degree burns would result in less than half a minute. Another bench mark for consideration is the subepidermal temperature of 72°C (162°F) which represents virtually instantaneous destruction of the skin. While the difference between the surface and the subepidermal temperatures of the skin may be great at very rapid heating rates, in exposures in excess of a minute this difference is insignificant. Thus, the observation of skin temperatures in the vicinity of 72°C (162°F) must be interpreted as indicative of infliction of severe burns.

With these guidelines in mind, table III and figure 19 reveal that, despite the forced air flow within the hood, the temperatures about the face would become intolerable in less than a minute with severe burns indicated on the forehead and left cheek occurring between 0.5 and 1 minute and on the right cheek between 1 and 1.5 minutes. (In this exposure the paint on the forehead of the manikin blistered, figure 28.) The throat area and right breast temperature indicated significant pain occurring within 5 minutes, and the left forearm, at 3 minutes. Although the left hand values attain 44°C, this level of temperature is borderline for pain perception (2) and would have to be maintained for hours before injury occurred (3). Other temperatures would be tolerable throughout, however, pain of the magnitude predicted on the face would certainly cause the subject to leave the area or take some kind of protective action, perhaps crouching or dropping to the floor, as figures 13 and 14 show that much lower air temperatures [135°C (275°F)] prevailed at the lower levels.

C O N C L U S I O N S

From this evaluation it is concluded that in a realistic, survivable, localized cabine fire similar to that used for this evaluation: 1) an unprotected flight attendant could not function effectively; 2) an attendant wearing the prototype garment with deficient visor could not function in an upright position for a reasonable period due to the effects of intense radiation and hot gases on the face and upper parts of the body but might be able to assist crawling passengers in escape efforts by crouching; 3) the protective garment appears to be adequate in combatting radiant energy impinging on the torso and limbs but failed in the region of the visor and hood where very high air temperatures enhanced the effect of the radiant exposure; 4) the hood and visor



Figure 27. Surface Thermocouple Locations.

B-39

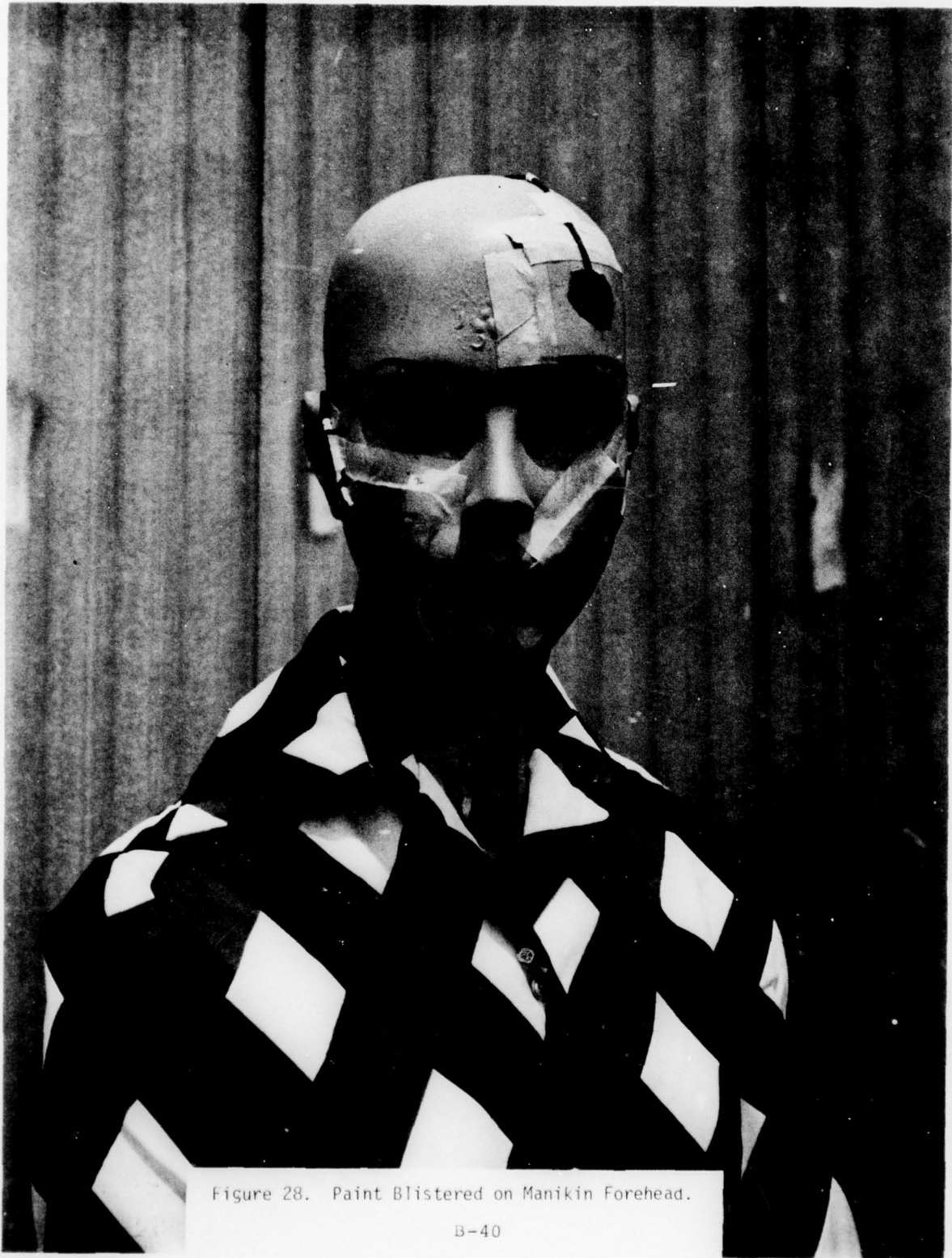

Figure 28. Paint Blistered on Manikin Forehead.

B-40

AD-A042 329

ILC INDUSTRIES INC FREDERICA DEL
DEVELOPMENT OF A FIRE PROTECTIVE OVERGARMENT FOR USE BY AIR CAR--ETC(U)
FEB 77 J F RAYFIELD

F/G 6/17

DOT-FA75WA-3696

UNCLASSIFIED

FAA-RD-77-18

NL

2 of 2
ADA042329



END
DATE
FILMED
8-77
DDC

of the protective garment should be redesigned to provide for reflection of radiant heat by the visor and overall protection against convective heat transfer, without seriously degrading visibility through the visor; 5) comparison of the data from this experiment with that obtained in the NASA closed-cabin fire shows that dramatic environmental differences can occur when cabin exits are open. For instance, if a good-sized opening (28" x 7'6" in this case) prevents, within five minutes, flashover in the compartment containing the fire, as it appears to do here, consideration might be given to provisions for venting the cabin when a post crash cabin fire occurs; 6) this study also revealed that laboratory evaluation of the thermal protective capacity of a fabric material to be used for this overgarment requires a heat-soaking test to prevent failures such as occurred in the hood area. At the distance from the fire source concerned here, in the absence of flashover, no flames contacted the manikin but the elevated air temperature near the ceiling produced the effect of an oven with consequent degradation of the material. Also refer conclusions on page B-38.

R E F E R E N C E S

1. Stuckey, R.N., D.E. Supkis and J.L. Price. Full-Scale Aircraft Cabin Flammability Tests of Improved Fire-Resistant Materials. Report No. TMX58141, NASA, June 1974.
2. Stoll, A.M. and L.C. Greene. Relationship Between Pain and Tissue Damage due to Thermal Radiation. *J. Applied Physiology* 14: #3, 373-382, May 1959.
3. Moritz, A.R. and F.C. Henriques, Jr. Studies of Thermal Injury II. The Relative Importance of Time and Surface Temperature in the Causation of Cutaneous Burns. *Am. J. Pathology* 23: 695-720, 1947.
4. Refer references page 34.