

AD-A042 337

AIR FORCE FLIGHT DYNAMICS LAB WRIGHT-PATTERSON AFB OHIO F/G 1/2
CREW ESCAPE CAPSULE RETROROCKET CONCEPT. VOLUME I. DEMONSTRATIO--ETC(U)
MAY 77 M C WHITNEY

UNCLASSIFIED

AFFDL-TR-76-107-VOL-1

NL

1 OF 1

ADA042337



END
DATE
FILMED
8-77

AD A 042337

AFFDL-TR-76-107
Volume I

12
NW

CREW ESCAPE CAPSULE RETROROCKET CONCEPT
Volume I
DEMONSTRATION PROGRAM

MAY 1977

TECHNICAL REPORT AFFDL-TR-76-107 Volume I
FINAL REPORT FOR PERIOD MAY 1972 - OCTOBER 1975

DDC
RECEIVED
AUG 3 1977
[Handwritten mark]

Approved for public release; distribution unlimited

AU NO. _____
DDC FILE COPY

AIR FORCE FLIGHT DYNAMICS LABORATORY
AIR FORCE WRIGHT AERONAUTICAL LABORATORIES
AIR FORCE SYSTEMS COMMAND
WRIGHT-PATTERSON AIR FORCE BASE, OHIO 45433

NOTICE

When Government drawings, specifications, or other data are used for any purpose other than in connection with a definitely related Government procurement operation, the United States Government thereby incurs no responsibility nor any obligation whatsoever; and the fact that the government may have formulated, furnished, or in any way supplied the said drawings, specifications, or other data, is not to be regarded by implications or otherwise as in any manner licensing the holder or any other person or corporation, or conveying any rights or permission to manufacture, use, or sell any patented invention that may in any way be related thereto.

Approved for public release, distribution unlimited. This report has been reviewed by the Information Office (OI) and is releasable to the National Technical Information Service (NTIS). At NTIS it will be available to the general public, including foreign nationals.

Requests for this report should be directed to: U. S. Dept of Commerce, National Technical Information Service, Washington, D. C. 20230.

This technical report has been reviewed and is approved for publication.

Marvin C. Whitney
MARVIN C. WHITNEY
Project Engineer

FOR THE COMMANDER
Ambrose B. Nutt
AMBROSE B. NUTT
Director
Vehicle Equipment Division

EXEMPTION FOR
NTIS
DISC
UNANNOUNCED
JUSTIFICATION

INT'S Section
Bufile Section

DISTRIBUTION AVAILABILITY CODES
DISC: *A*

AVAIL. ONLY BY SPECIAL

Copies of this report should not be returned unless return is required by security considerations, contractual obligations, or notice on a specific document.

UNCLASSIFIED

7 DIAMETER

SECURITY CLASSIFICATION OF THIS PAGE(When Data Entered)

20. parachute bridle system) was used for the test program. A cluster of four rocket motors with a high level primary thrust and a low level sustainer, that had been developed for the NASA Gemini Program, was installed at the confluence of the three 69.8 foot D_0 slotted ring sail recovery chutes and the vehicle bridle system. A mechanical altimeter or telescoping probe was developed to extend down below the vehicle to trigger the rocket ignition at the correct time so as to decelerate the vehicle from 30 ft/sec down to 10 ft/sec or less before ground impact. Eight tests were conducted in developing the demonstration system with the last test a complete retrorocket system test. Test results and the rocket performance computer program indicated the demonstration program met design requirements.

UNCLASSIFIED

SECURITY CLASSIFICATION OF THIS PAGE(When Data Entered)

AFFDL-TR-76-107
Volume I

PREFACE

This report summarizes a crew escape capsule retrorocket demonstration and analytical program which was conducted by the Air Force Flight Dynamics Laboratory, Vehicle Equipment Division, Air Force Systems Command, Wright-Patterson Air Force Base, Ohio. This report consists of two volumes:

Volume I - Demonstration Program

Volume II - Selection of a Retrorocket System

The program was conducted under Project 6065, "Aerospace Vehicle Recovery and Escape Subsystems"; Task 606501, "Aerospace Vehicle Escape"; and In-House Effort 60650120, "Crew Escape Capsule Retrorocket Concept." Mr. Marvin C. Whitney of the Recovery and Crew Station Branch, AFFDL, was the Project Engineer. Mr. James M. Peters of the Recovery and Crew Station Branch conducted the analytical program.

The flight tests were conducted at the National Parachute Test Range (NPTR), El Centro, California. Support was provided by Lt. G. Fried and Mr. R. Caulkins of the 6511th Test Squadron, Air Force Flight Test Center and Mr. Rafael Felix, Solid Rocket Division, Air Force Rocket Propulsion Laboratory.

AFFDL-TR-76-107
Volume I

The author is indebted to the following Air Force Flight Dynamics Laboratory personnel who supported the demonstration program: Messrs. R. J. Dobbek, L. Jines, V. King, B. J. White, and Capt. A. M. Higgins.

TABLE OF CONTENTS

SECTION		PAGE
I	INTRODUCTION	1
II	RETROCKET DEMONSTRATION TEST PROGRAM	5
	1. TEST VEHICLE	5
	2. ROCKET MOTORS	11
	3. CONFINED DETONATING FUSE (CDF) SYSTEM	12
	4. RIGID MECHANICAL ALTIMETER (PROBE)	15
	5. SEQUENCE SYSTEM	20
	6. INSTRUMENTATION	23
	6.1 ON-BOARD SENSORS AND TELEMETRY	23
	6.2 ON-BOARD CAMERA COVERAGE	27
	6.3 AIR-TO-AIR CAMERA COVERAGE	29
	6.4 GROUND-TO-AIR CAMERA COVERAGE	29
	6.5 SPACE POSITIONING	29
III	TEST PROCEDURES AND RESULTS	30
	1. ROCKET CLUSTER STATIC FIRING TEST	30
	2. FUNCTIONAL TESTS	33
	2.1 STATIC FUNCTIONAL TEST	33
	2.2 WEIGHTED TUB PICK-UP TEST	35
	2.3 WEIGHTED TUB DROP TEST	37
	2.4 VEHICLE PICK-UP TEST	38
	2.5 VEHICLE FUNCTIONAL TEST #6	41
	2.6 VEHICLE FUNCTIONAL TEST #7	44
	3. RETROCKET TEST	48
IV	CONCLUSIONS	62
	REFERENCES	63
	APPENDIX A. IGNITION HEIGHT ERROR AND PROBE LENGTH CALCULATIONS	65

LIST OF ILLUSTRATIONS

FIGURE		PAGE
1	Full-Scale F-111 Crew Capsule Drop Test Data	3
2	Retrorocket Demonstration Test System	6
3	Test Vehicle - Equipment Location	8
4	Test Vehicle - Sideview	9
5	Test Vehicle - Three Quarter View	10
6	Retrorocket Cluster and Support	13
7	Retrorocket Motor System Schematic	14
8	Probe Assembly - Extended	16
9	Probe Assembly	18
10	Reefing Line Cutter	19
11	Sequence System - Original	21
12	Data Acquisition System	24
13	Weighted Tub Test Set-Up	36
14	Weighted Tub After Pick-Up	39
15	Weighted Tub After Drop Test	40
16	Sequence System - First Modification	42
17	Sequence System - Final Modification	45
18	Vehicle Connected to Helicopter - Ready for Lift-Off	49
19	Vehicle and Support Stand	50
20	Rocket Cluster/Confluence Fitting	51
21	Helipad	52
22	Vehicle - Helicopter	53
23	Vehicle Before Release	54

AFFDL-TR-76-107
Volume I

LIST OF ILLUSTRATIONS - Concluded

FIGURE		PAGE
24	Vehicle - Full Chute Deployment	55
25	Vehicle - Probes Extended	56
26	Rocket Firing	60

AFFDL-TR-76-107
Volume I

LIST OF TABLES

TABLE		PAGE
I	Data Acquisiton Equipment	25
II	Characteristics of Sink Rate Radar	28
III	Test Program Summary	31

SECTION I
INTRODUCTION

With the development of crew escape capsules, a technique had to be developed to attenuate the landing impact forces since these forces far exceeded human tolerances. To remedy this problem for the F-111 escape capsule and later the B-1 escape capsule, inflatable airbags were developed. After ejection but before impact, the airbags (installed on the bottom of the capsule) are inflated. Upon impact the bags compress and, at a predetermined pressure, plugs are blown out, deflating the bags at a controlled rate to attenuate the impact forces and keep them within human tolerances. The airbags are satisfactory for attenuating the impact forces when the capsule is descending vertically with no horizontal velocities. However, capsule specifications require tolerable ground impact accelerations with a 20 knot wind component and parachute oscillations up to $\pm 10^\circ$. This combination can result in a horizontal velocity of 43 fps at ground impact. The capsule is also free to yaw during descent; if it should be yawed 90° in relation to a horizontal velocity exceeding approximately 10 fps at impact, the impact forces will exceed human tolerances. This is due to the tendency of the bags to roll out from under the vehicle when there is a horizontal velocity. This is especially critical when the vehicle is yawed 90° . In addition, the crewmember is not very well restrained and protected in the lateral direction, and the human tolerances are also low in that direction.

The Air Force Flight Dynamics Laboratory conducted a test program with an F-111 crew escape capsule and verified the above criteria. The results of these tests are documented in Reference 1. Figure 1 graphically illustrates that the probability of injury increases substantially for the airbag attenuation system when the lateral velocity is increased. The probability of spinal injury is based on the dynamic response index (DRI) which is a model representation of the maximum dynamic compression of the human vertebral column. In physical terms, the DRI is calculated by describing the human body in terms of an analogous, lumped parameter, mechanical model consisting of a mass, spring, and damper. The DRI is a measure of the mass displacement when the mass has been subjected to impact acceleration pulse. The figure shows that for vertical drops at 30 fps with airbags, with no lateral velocity, the DRI's were calculated to range from 17 to 19 which corresponded to a five percent probability of a disabling spinal injury. When the lateral velocity was increased to 35 fps, the DRI's were calculated to be greater than 22 which indicated that the probability of disabling spinal injuries would be greater than fifty percent. Preliminary results from drop tests of the B-1 capsule airbag impact attenuation system showed similar excessive acceleration levels (Ref. 2). Figure 1 also shows the results from impact tests of the same F-111 capsule utilizing only the capsule structure for impact attenuation but at a lower vertical velocity. Evaluating the test data led to establishing the criteria that, if the landing impact velocity was 10 ft/sec or less, the impact loads experienced by the occupants would be within human tolerances and the resulting DRI would be within the requirements of Reference 3.

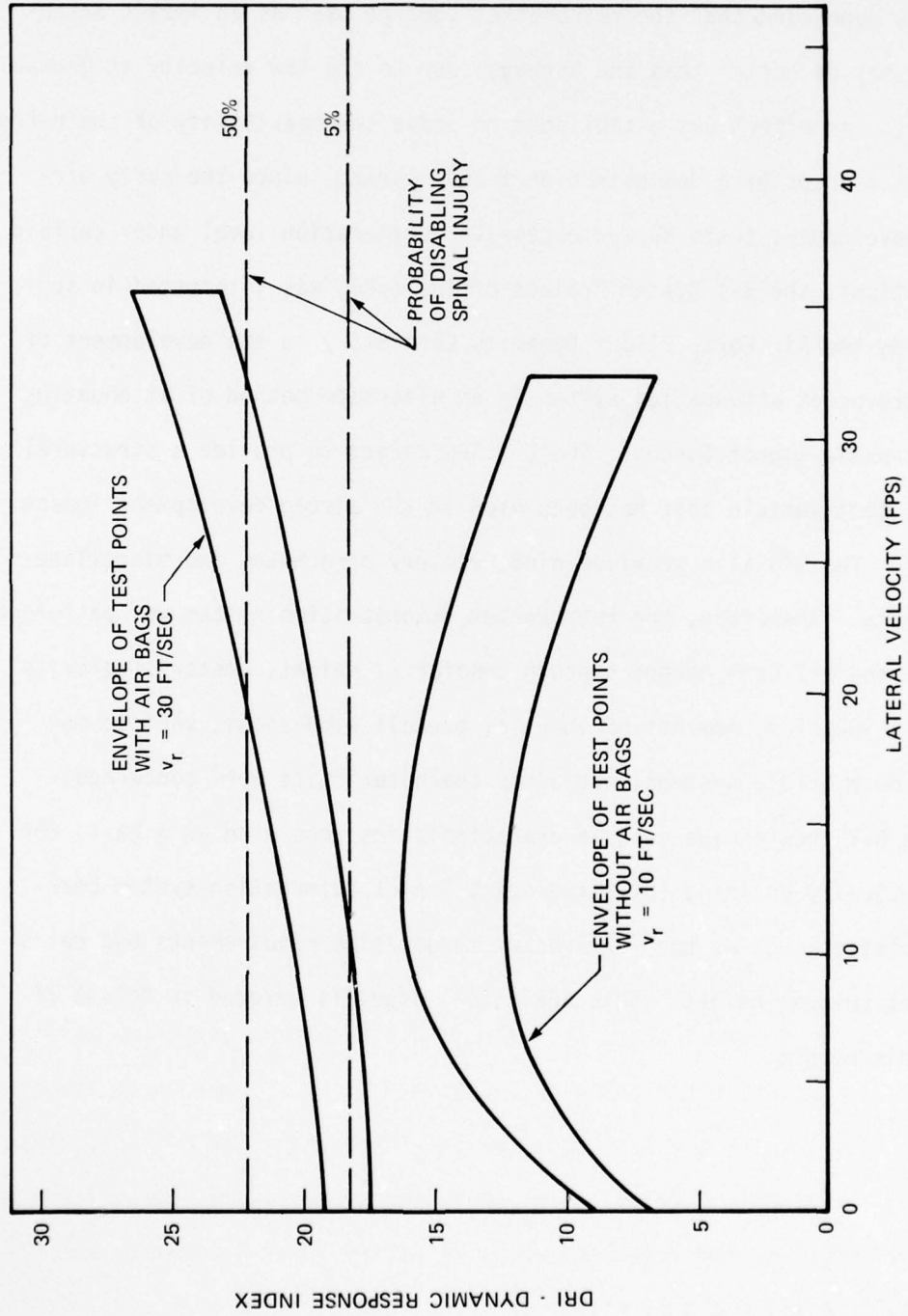

Figure 1. Full-Scale F-111 Crew Capsule Drop Test Data

Based on the above studies and the analyses covered by Volume II, it was concluded that the retrorocket concept used as an impact attenuator may be better than the airbags, due to the low velocity at ground impact. An effort was established to prove the feasibility of the retrorocket concept by a demonstration test program. Since the early airbag development tests showed excessive acceleration level under certain conditions, the B-1 System Project Office (SPO) was interested in supporting the Air Force Flight Dynamics Laboratory in the development of a retrorocket attenuation system as an alternate method of attenuating the capsule impact forces. The B-1 SPO agreed to provide a structural steel test vehicle that had been used in the airbag development impact tests. The SPO also provided *nine recovery parachutes and miscellaneous data*. Therefore, the retrorocket demonstration system was patterned after the B-1 crew escape capsule insofar as weight, center of gravity (C.G.) location, moments of inertia, overall dimensions, vehicle and parachute bridle systems, and other characteristics were concerned. These B-1 crew escape capsule characteristics were used as a basis for analytically defining the retrorocket impact attenuation system characteristics such as the retrorocket thrust/time requirements and retrorocket trigger height. This analytical study is covered in Volume II of this report.

SECTION II
RETROCKET DEMONSTRATION TEST PROGRAM

The objective of this program was to demonstrate the feasibility of a retrorocket system as an impact load attenuator for a crew escape capsule by providing a low velocity at ground impact. The testing method selected to meet this objective is shown in Figure 2 and functioned as follows. The test system was carried to test altitude by a CH-53 helicopter and released. Three 69.8 foot D_0 slotted ring sail recovery parachutes were deployed, providing a descent velocity of 30 fps. Probes located under the vehicle contacted the ground, providing a signal to initiate the retrorockets located at the confluence point of the vehicle parachute bridle systems. Rocket thrust decelerated the vehicle to 10 fps or lower before impact. Instrumentation was incorporated into the system to provide impact accelerations and velocities to verify the predicted performance. The final demonstration system was selected on the basis of being able to demonstrate the concept, yet utilize off-the-shelf items wherever possible so as to keep the overall cost of the demonstration program to a minimum.

1. TEST VEHICLE

The basic test vehicle (Iron Mule) was a structural steel framework designed to simulate the base (footprint) area of the B-1 crew escape capsule. The overall dimensions, center of gravity (C.G.) and mass distribution were similar to the B-1 capsule. The weight and C.G.

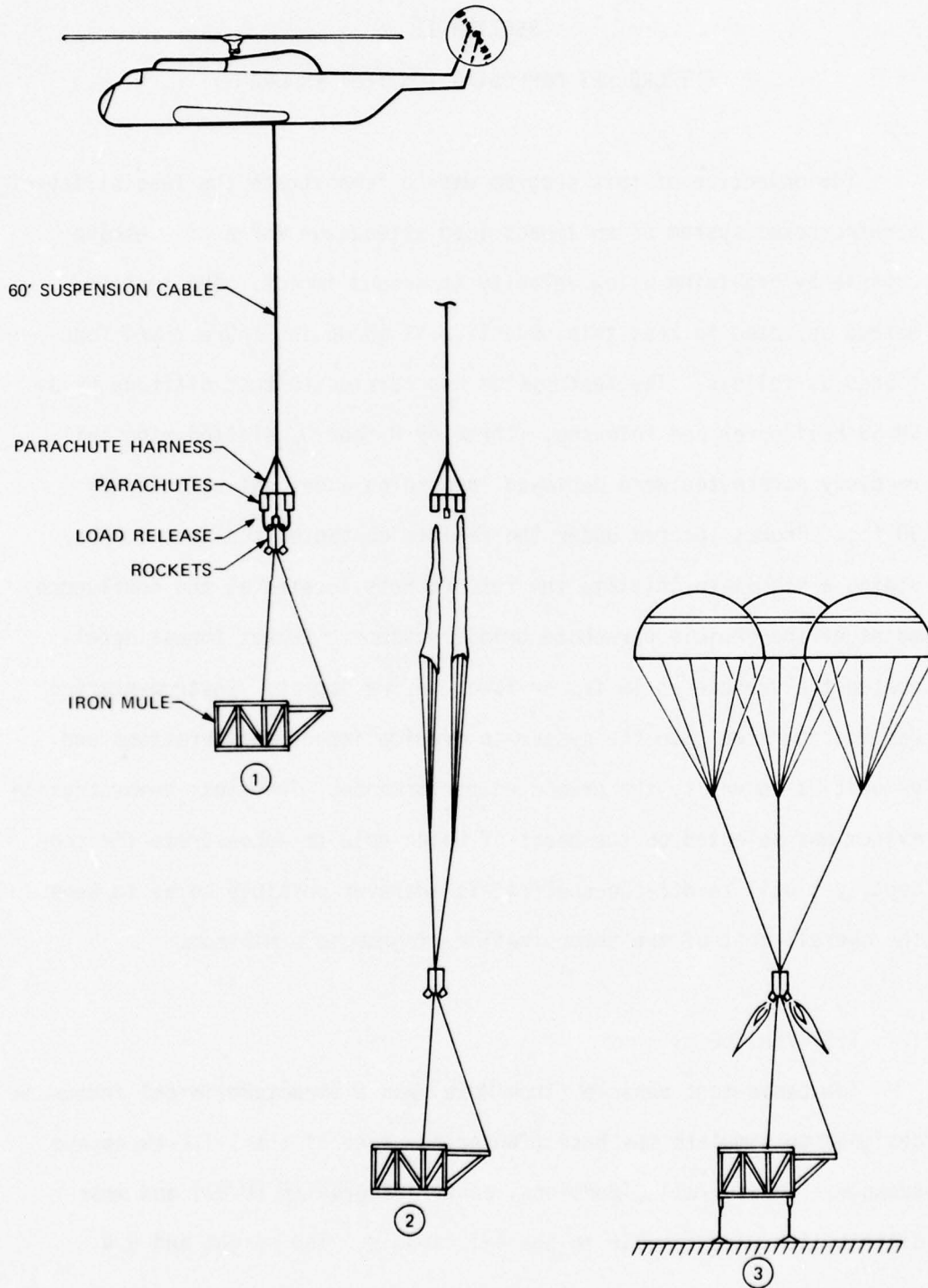
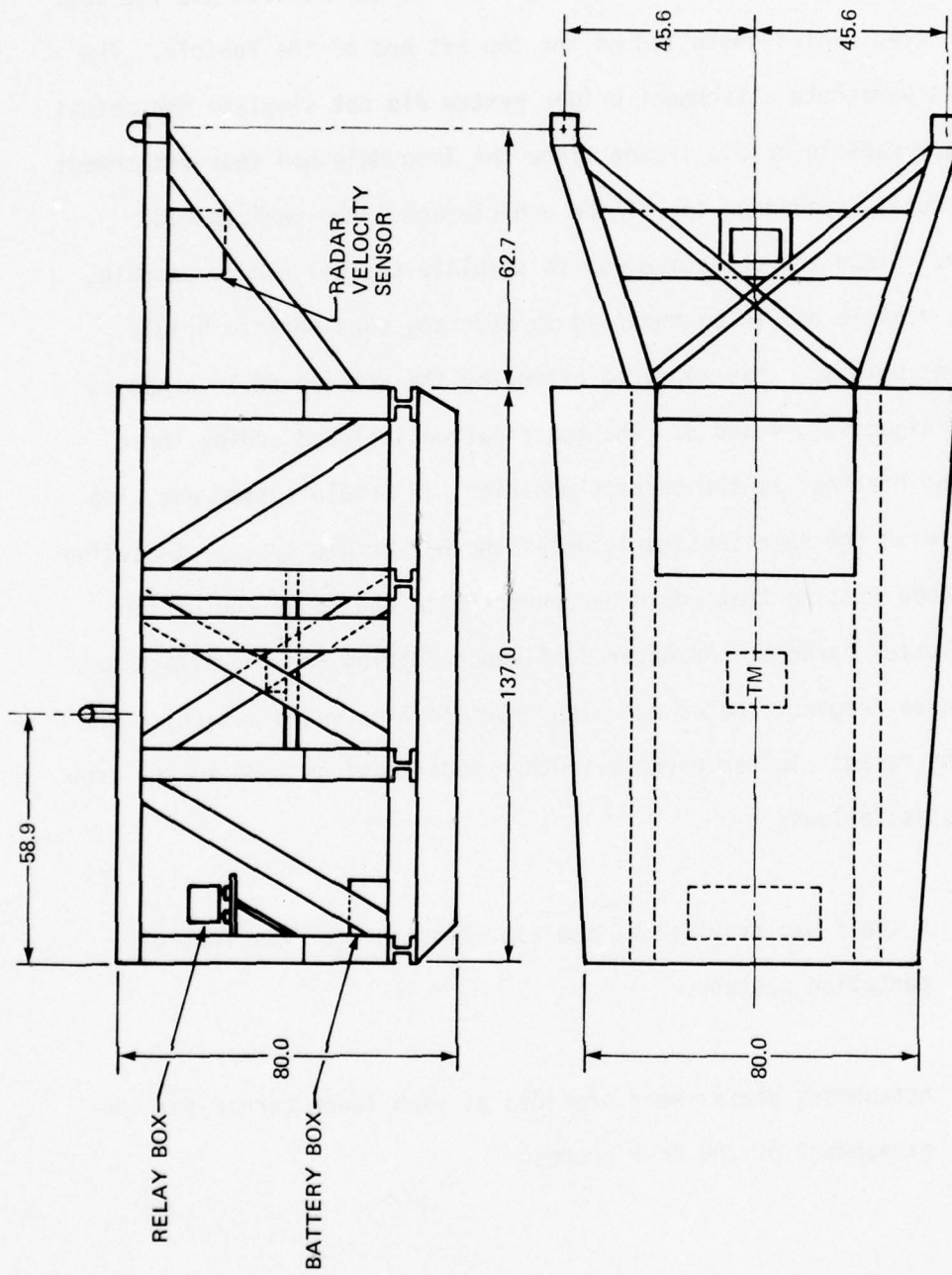

Figure 2. Retrorocket Demonstration Test System

location of the vehicle could be varied by adding or removing six, 96-pound lead plates installed on the top front of the vehicle and the ten, 96-pound lead plates installed on the top aft end of the vehicle. The vehicle's parachute attachment bridle system did not simulate the actual B-1 escape capsule bridle system since the Iron Mule had four attachment points equally spaced on top of the vehicle about the vehicle C.G. location. Since the objective was to simulate the B-1 escape capsule, the test vehicle had to be modified to have the same vehicle bridle attachment points. This required extending the vehicle 62.7 inches as shown in Figures 3, 4 and 5. The modification included adding three attachment fittings at the correct position. A bridle system was also provided with the same configuration as the B-1 bridle system, including a confluence fitting that would be connected to the lower end of the rocket cluster harness. An upper confluence fitting for the attachment of the three recovery chutes was also provided that would attach to the top of the rocket cluster harness. Other modifications made to the Iron Mule were as follows:

- a. A shelf was provided at the C.G. location for the instrumentation package.
- b. Attachment plates were provided at each lower corner for the attachment of the four probes.



NOTE: ALL DIMENSIONS IN INCHES

Figure 3. Test Vehicle - Equipment Location

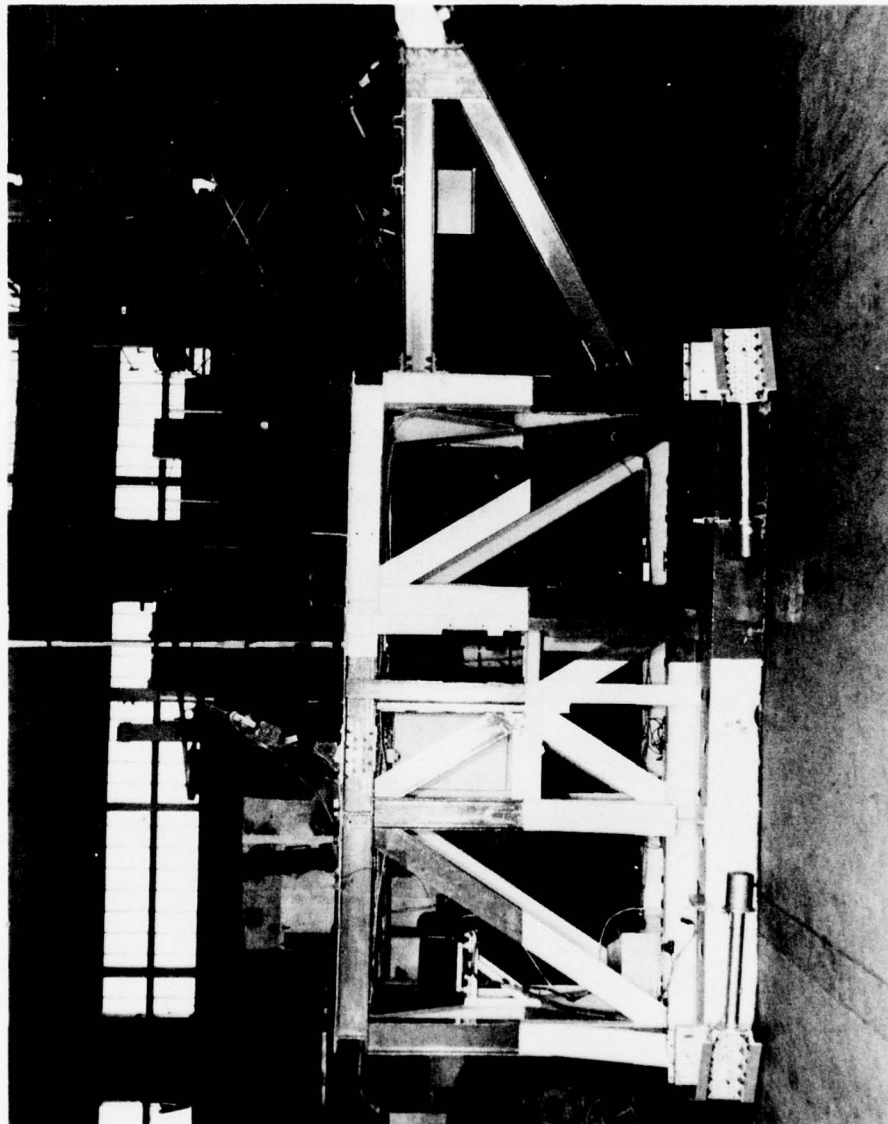

Figure 4. Test Vehicle - Sideview

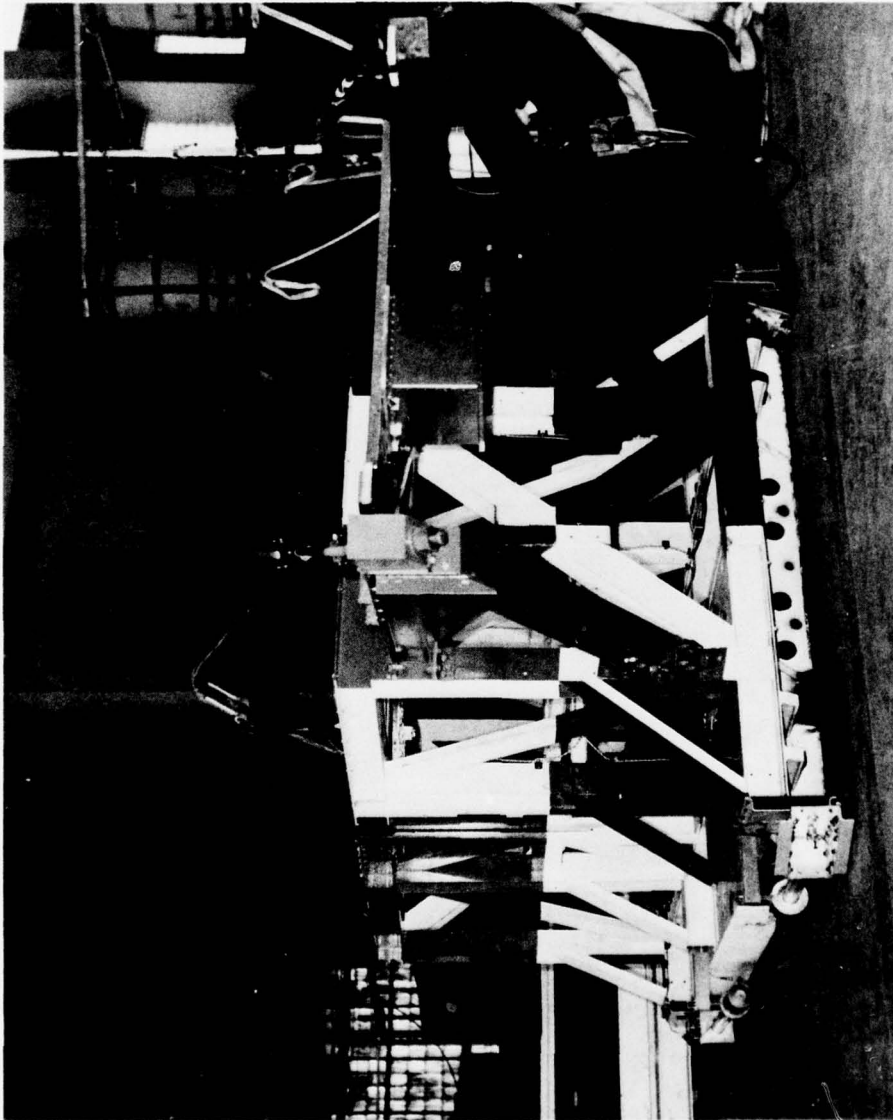

Figure 5. Test Vehicle - Three Quarter View

AFFDL-TR-76-107
Volume I

- c. A power source (batteries and metal box) was installed on the floor of the vehicle at the forward end.
- d. A relay box with wiring was installed at the forward end of the vehicle.
- e. A protective cover plate was installed on top of the vehicle.
- f. Camera mounts were provided for four cameras.

The final test weight of the vehicle, bridle system and rocket cluster was 8083 pounds. The longitudinal C.G. location of the vehicle (measured from the front edge of vehicle) was 82.1 inches. The longitudinal C.G. location for the B-1 capsule was 78.4 inches. Hanging from the bridle system, the test vehicle was tail heavy due to the C.G. being 3.7 inches aft of the design location. The nylon lanyard sections of the aft two legs of the bridle system had to be shortened six inches in order for the vehicle to hang level.

2. ROCKET MOTORS

The analytical study contained in Volume II determined the rocket thrust/time requirements needed to provide the 10 fps vertical impact velocity. A family of thrust/time curves were generated and, using these, a search was made of all available off-the-shelf rocket motors. A rocket motor, Thiokol TE-M-421-3, developed for NASA for the Gemini

Space Capsule Soft Landing Project had a thrust/time curve similar to what was required if clustered together in a group of four motors (see Figure 6). NASA offered to supply a number of TE-M-421-1 rocket motors which were similar to, but an earlier version of, the TE-M-421-3 motor with a slightly different thrust/time curve. The economics of the program dictated that the -1 rocket motor be used even though the rocket ignition height was decreased by 19.8 inches. The analytical study and all information concerning these two rocket motors is covered in Volume II and Reference 4.

3. CONFINED DETONATING FUSE (CDF) SYSTEM

A signal transfer system was required to transmit the signal generated when the probes contact the ground to the rocket motor ignition system. A number of systems could have been utilized; however, the demonstration system was required to be compatible with the B-1 capsule which utilized confined detonating fuse (CDF) transfer systems to detonate the linear shaped charge separation system, sequence system and the escape rocket motor. CDF consists of a small amount (2 grains per foot) of an explosive inside a woven covering to protect the explosive and to contain the explosion when it is detonated. It has an average detonating velocity of 6000 meters per second.

The system shown in Figure 7 consisted of four, 24-foot CDF lines from the four probes up to a six-port manifold located near the top of the vehicle, just forward of the front bridle attachment fitting. Two,

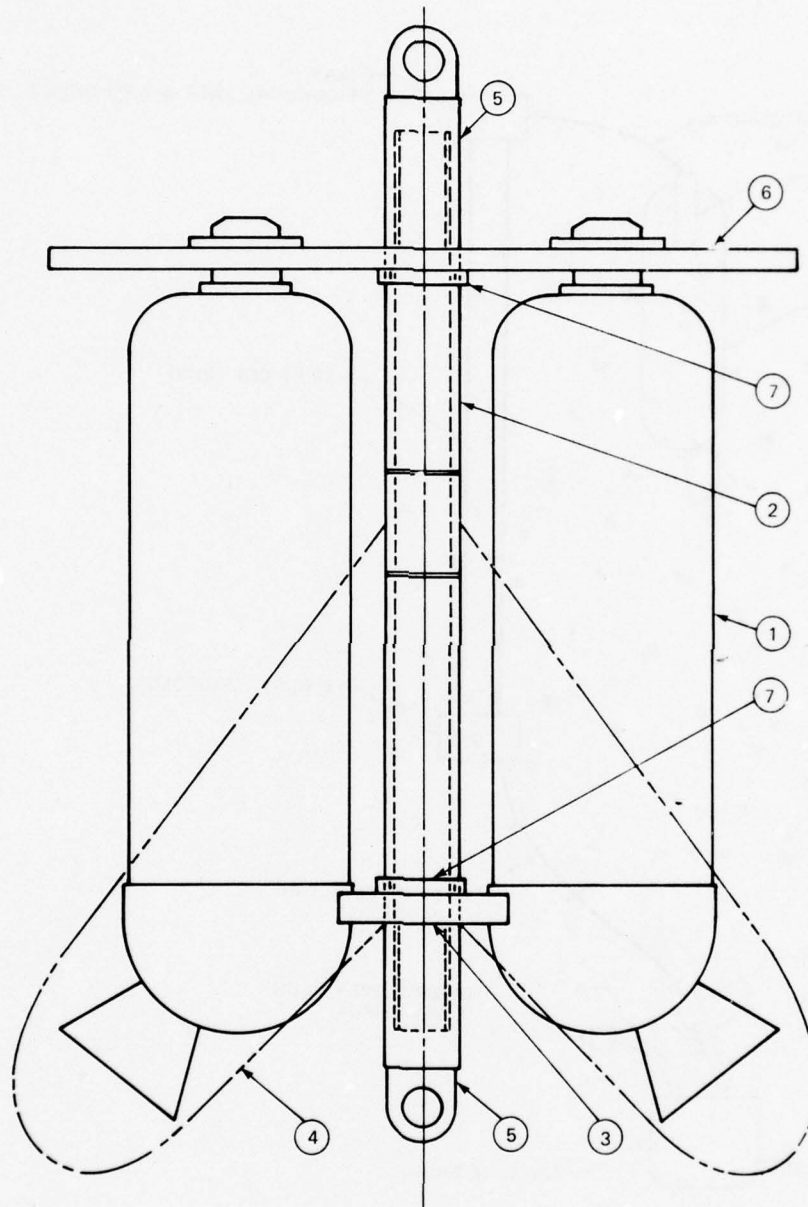

- | | |
|------------------|-----------------------|
| ① ROCKET MOTOR | ④ FRAME SUPPORT |
| ② COLUMN | ⑤ ADAPTER |
| ③ BOTTOM COUPLER | ⑥ FOR'D CLUSTER PLATE |
| | ⑦ COLLAR |

Figure 6. Retrorocket Cluster and Support

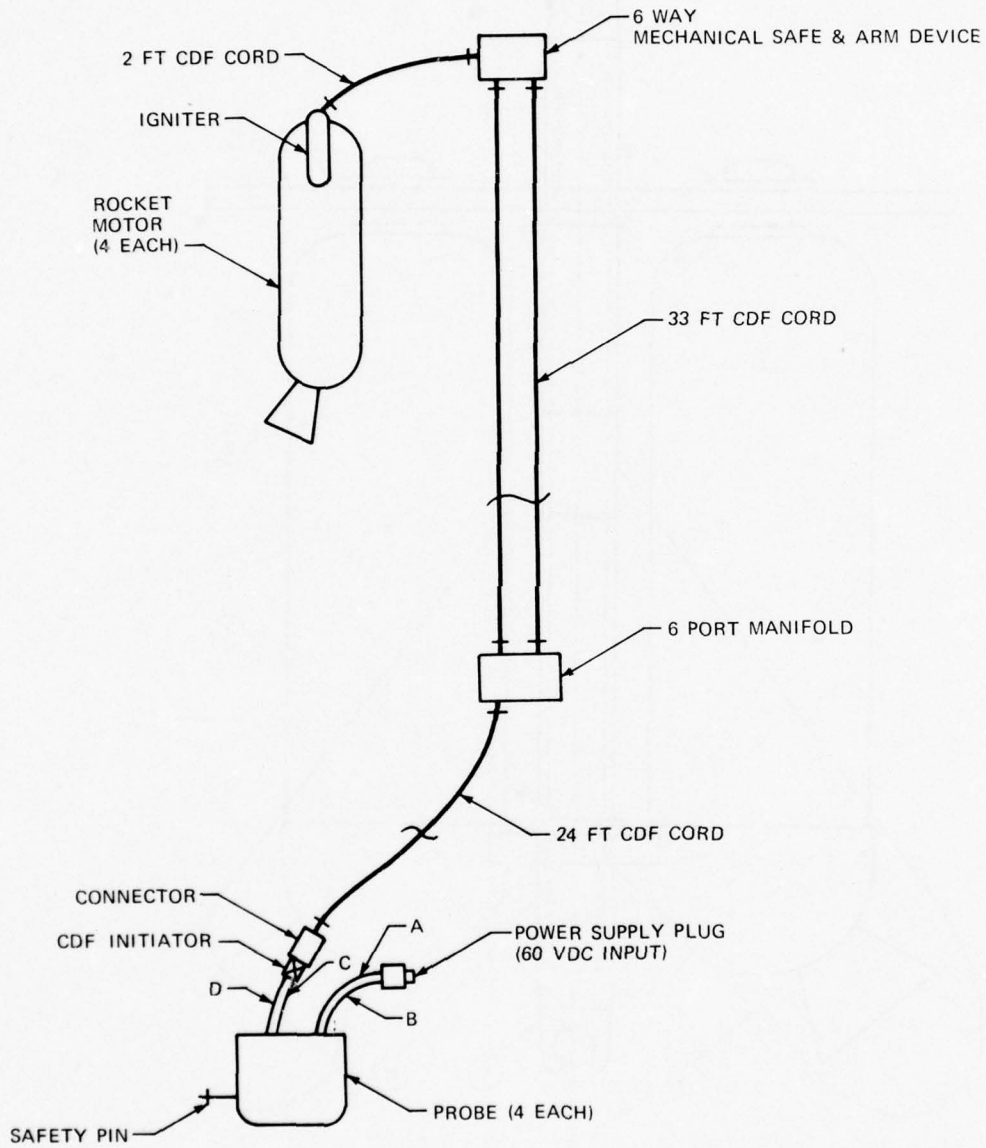

Figure 7. Retrorocket Motor System Schematic

AFFDL-TR-76-107
Volume I

33-foot CDF lines continue out of this manifold, up the vehicle forward bridle cables to the safe-and-arm six-port manifold located on the rocket cluster harness. Four rocket CDF lines continue from the safe-and-arm device up to the four individual rocket motors. The probes contacting the ground close a microswitch to electrically fire a CDF initiator, which in turn detonates the CDF transfer system. This will ignite the rocket motors unless interrupted by the safe-and-arm device. The safe-and-arm device is in the safe position on the ground and up to the time of release of the vehicle. Upon release it is switched to the armed position and will not interrupt the CDF transfer system. Its function is to guard against the accidental firing of the rocket motors until after the test vehicle has been released from the helicopter.

4. RIGID MECHANICAL ALTIMETER (PROBE)

One of the most critical items in the retrorocket concept is the timing of the ignition of the rocket motors which must occur at a precise distance above the terrain in order to decelerate the test vehicle to 10 feet per second or less before ground impact. This requires a height above ground sensor or an altimeter. A number of techniques (radar altimeter, laser beam) are available that can indicate height above ground and these are tabulated in Reference 5. After a review of all techniques, a mechanical altimeter or telescoping probe was selected as being the optimum for this application. The probe design shown in Figure 8 utilizes a telescoping tubular member made by prestressing a spirally wound ribbon of spring stainless steel. This was stored in a canister five inches in diameter and seven inches in height.

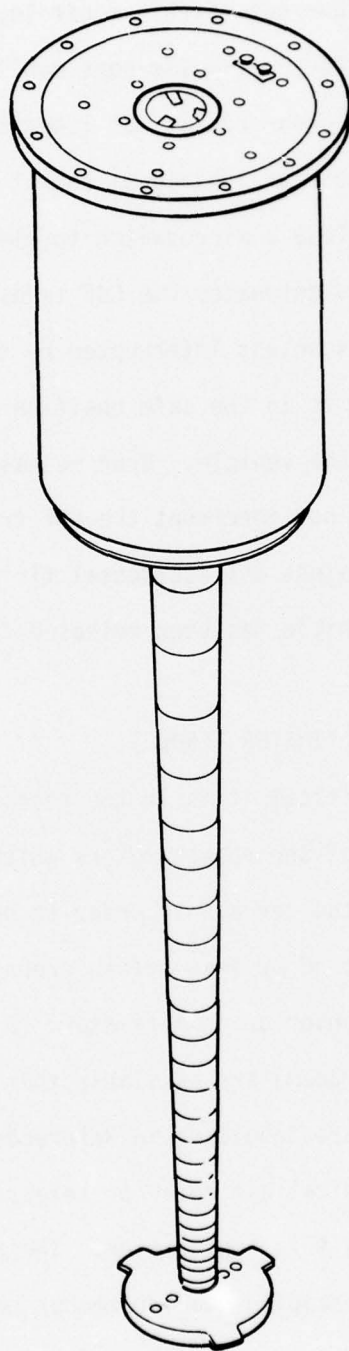

Figure 8. Probe Assembly - Extended

The probe design was frozen before a final decision was made concerning which rocket motors would be used on the demonstration program. The probe design was based on a rocket motor that provided a thrust to weight ratio (T/W) of five. The probe was therefore designed with an extension of 84 inches based on that rocket design. When the TE-M-421-3 rocket motors, with a T/W of approximately three, were considered for the program, the probe height would had to have been increased by 41.6 inches. With the final decision to use the TE-M-421-1 rocket motors, with a different thrust/time curve, the probe height was reduced and only had to be increased by 21.8 inches. Since the probe design was already frozen, an extension was installed (see Figure 9) on the vehicle bracket where the probe was to be installed. By installing the probe on the end of this extension, the rocket ignition was correct; however, the vehicle would now stand on the four probe extensions since they projected below the vehicle by 21.8 inches at each corner of the vehicle. To eliminate this problem, the probe extension and vehicle mounting bracket were designed as shown in Figure 9 so they could be rotated up to the horizontal position flush with the bottom of the vehicle while sitting on the ground. The probes and extensions would then rotate down to the vertical position after vehicle lift off. To retain the probe, extension and mounting bracket in the stowed horizontal position, a bracket was installed on the vehicle over the stowed probe, where the probe attaches to the extension. A 250-pound nylon line between the probe and bracket was used to tie the probe extension bracket up in the stowed position. A line cutter was then installed on the bracket as shown in Figure 10 so that the 250-lb

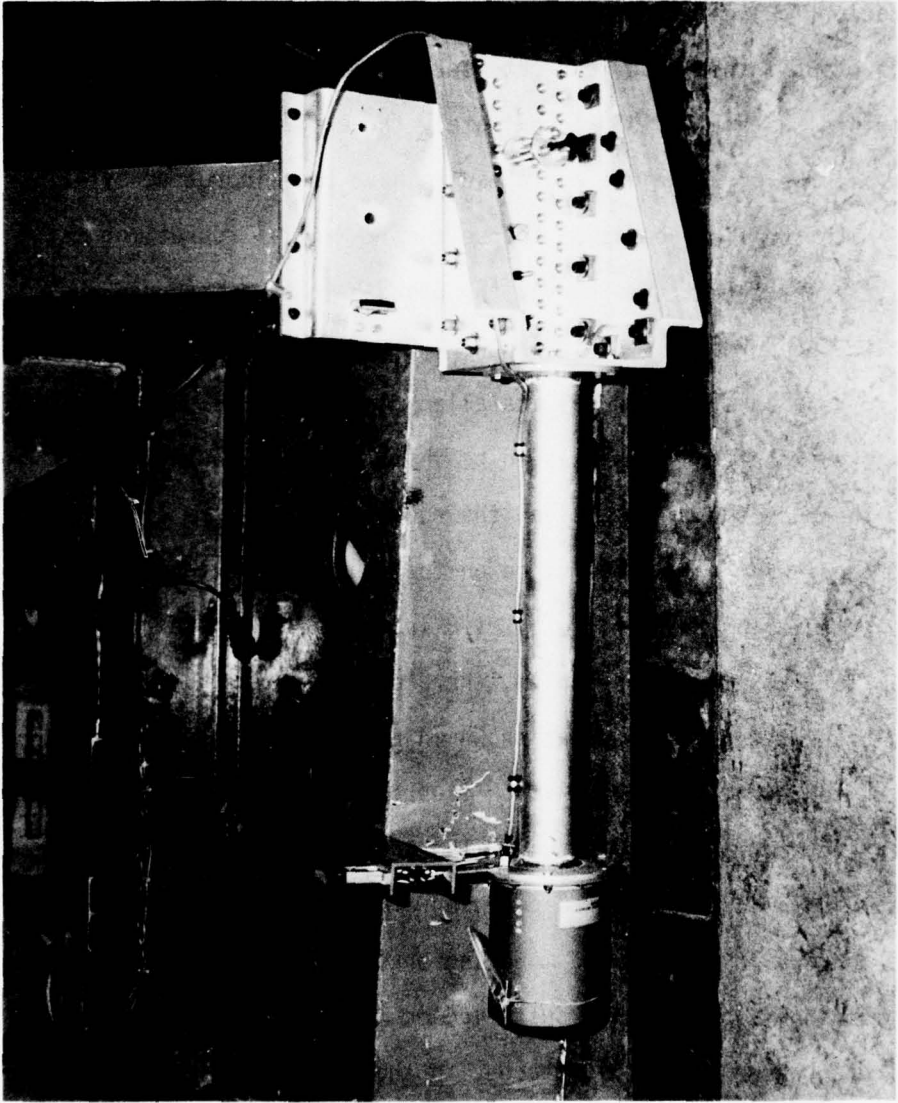

Figure 9. Probe Assembly

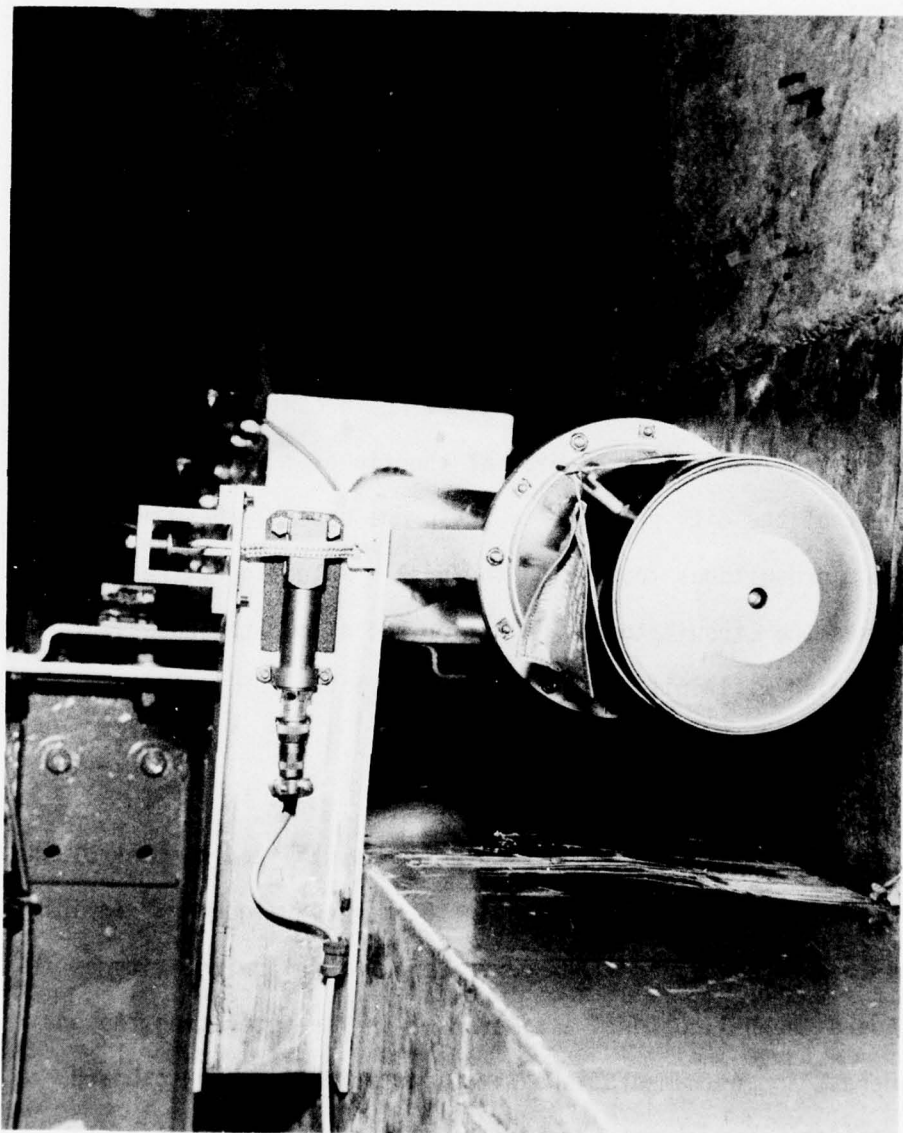
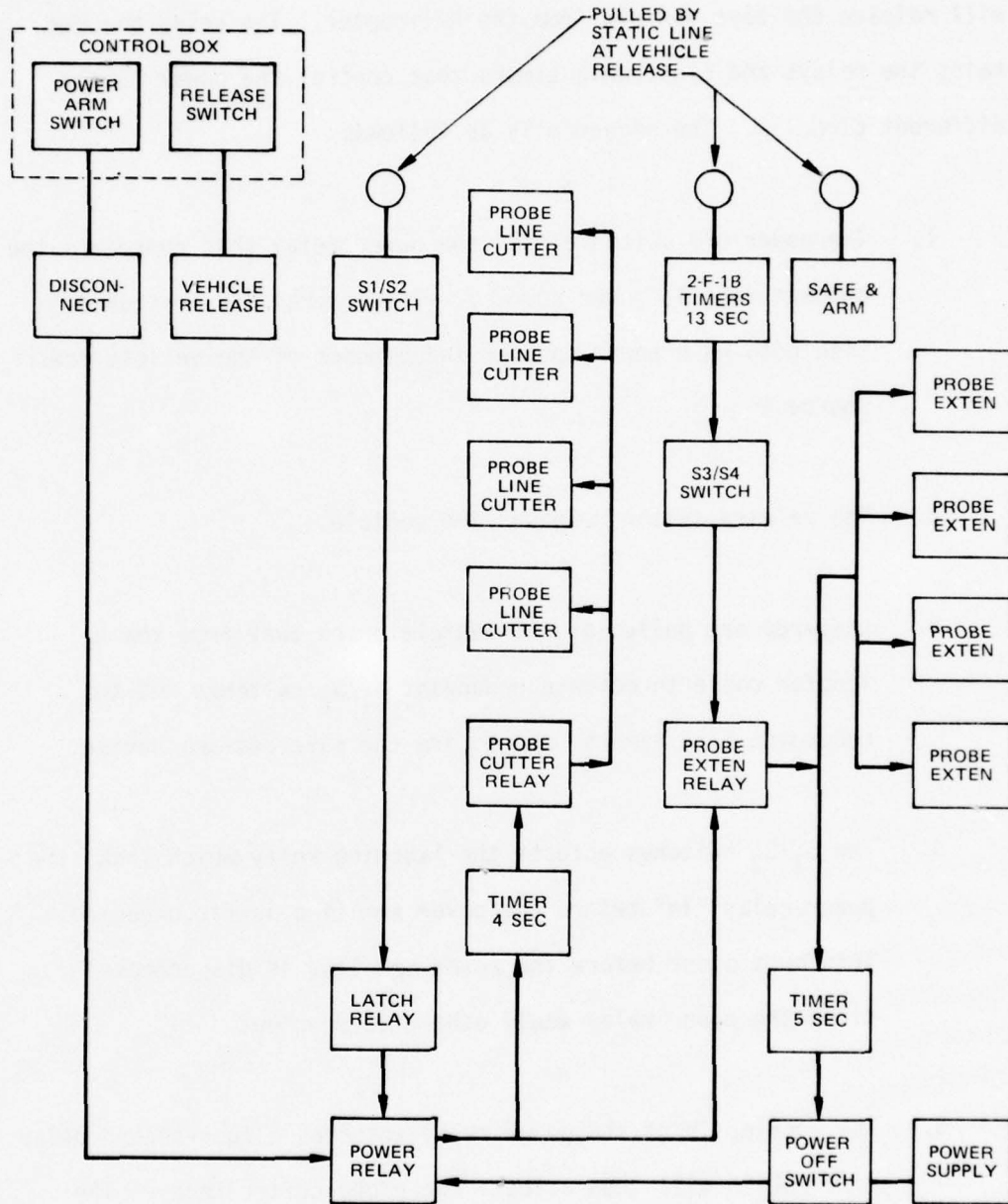

Figure 10. Reefing Line Cutter

nylon line could be cut when the cutter was actuated. This cutter is controlled by the sequence system. The probe extension is also controlled by the sequence system. When the probe extension relay is closed, this completes the circuit to the power source so that the input voltage of 60 VDC actuates a solenoid which then releases the telescoping tubular member. The member extends to a length of $84 \pm .25$ inches. As the member starts to extend, the input voltage energizes an "electric match" which is part of a thermal battery. When energized, the "electric match" melts the battery electrolyte and begins to generate a voltage which charges a capacitor. Tube extension and power source activation occur simultaneously. Terrain contact is sensed through a spring-loaded conical disk at the tip of the probe assembly. Displacement of the disk relative to the probe assembly beam actuates one of two microswitches located on the disk. Actuating either microswitch closes the circuit to the capacitor and allows the capacitor to discharge, which will initiate the electroballistic CDF initiator.

5. SEQUENCE SYSTEM

The sequence system shown in Figure 11 was utilized to control the different actions that must function in the correct sequence. To initiate this sequence a control box containing the following switches is placed aboard the helicopter: a camera switch for activating the onboard cameras, an instrumentation switch for activating the onboard instrumentation, and a power arm switch used to close the relay that energizes the onboard vehicle power source. The control box also contains two switches (one redundant) that actuate the release fitting that



NOTE: POWER RELAY WILL DROP-OUT UNLESS LATCHING RELAY IS ACTUATED BEFORE POWER ARM LINE IS DISCONNECTED

Figure 11. Sequence System - Original

will release the test vehicle from the helicopter. The relay box contains the relays and electronic timers that control the power to the different circuits. The sequence is as follows:

1. The power arm switch closes the power relay that energizes the onboard vehicle power source. (The cameras and instrumentation both have power sources independent of the vehicle power source.)
2. The release switch releases the vehicle.
3. Lanyards are pulled as the vehicle drops away from the helicopter cable to actuate redundant S_1/S_2 switches and two redundant F-1B timers, and to arm the safe-and-arm device.
4. The S_1/S_2 switches actuate the latching relay which locks the power relay "in" before the power arm line is disconnected. This must occur before the power arm line is disconnected since the power relay would otherwise drop out.
5. The locking in of the power relay actuates a four-second delay timer which will then actuate the probe cutter relay. The actuation of this relay will fire the electric initiators of the probe line cutters, resulting in the probe lines being cut and permitting the probe assemblies to rotate down and lock in the vertical position.

6. The F-1B timers that are actuated at vehicle release are set for 13 seconds. At the end of this delay, the redundant S_3/S_4 switches are actuated which then actuates the probe extension relay. This relay actuates the solenoids located in each probe, resulting in the extension of the four probes.

7. The actuation of the probe extension relay also actuates a five-second delay timer which in turn switches off the vehicle power source (excluding the camera and instrumentation power sources) so that on impact there is no power in the sequence system to cause shorts.

6. INSTRUMENTATION

6.1 ON-BOARD SENSORS AND TELEMETRY

- a. Pulse Amplitude Modulated (PAM) System - A pulse amplitude modulated telemetry system with thirty-two channels was installed on the vehicle to transmit all the data required by this test program. Fifteen accelerometers were installed to sense triaxial acceleration data from each corner and from the center of gravity (C.G.) of the vehicle. Pitch, roll and yaw rate gyros were also installed at the vehicle C.G. location. Strain links were installed to sense loads on each leg of the bridle system, the rocket motors' thrust, and each parachute's drag load. Two channels were set aside for the radar velocity sensor, one to record pulse data and the other to record analog data. One channel was used to record time of events (release, rocket firing and impact). The physical location of the equipment is shown in Figure 12 and the individual items are listed in Table I.

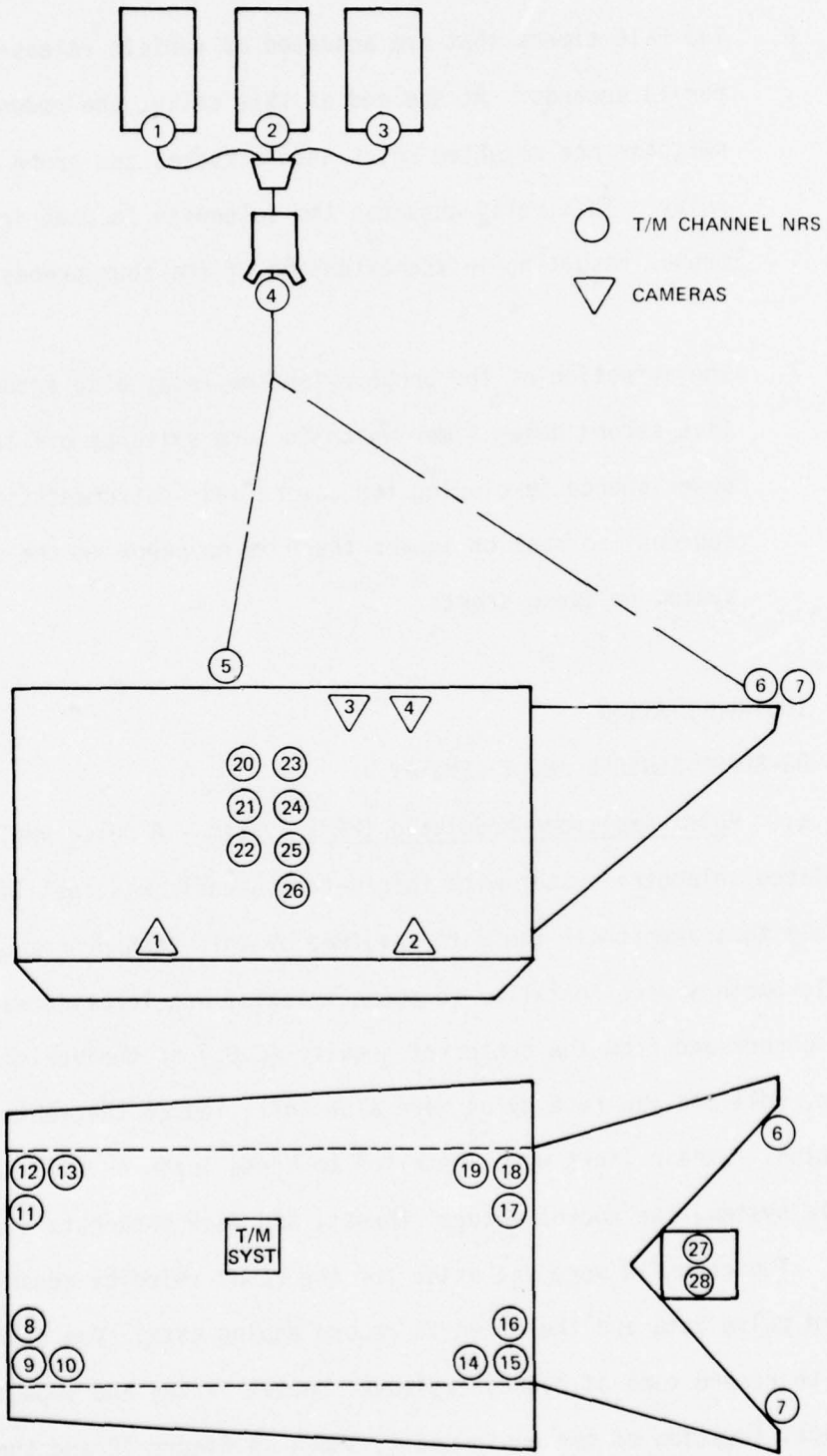

Figure 12. Data Acquisition System

TABLE I
DATA ACQUISITION EQUIPMENT

TM CH	PARAMETER	DIRECTION	SENSING ELEMENT	
			MODEL	RANGE
1	Parachute #1 Force		Strain Link	7.5K
2	Parachute #2 Force		Strain Link	7.5K
3	Parachute #3 Force		Strain Link	7.5K
4	Rocket Thrust		Strain Link	60K
5	Front Bridle Force		Strain Link	60K
6	Rear, R. Bridle Force		Strain Link	20K
7	Rear, L. Bridle Force		Strain Link	20K
8	Crew Sta., Fwd L.	Vert	Accelerometer Kulite-GA(E)813	±150G
9	Crew Sta., Fwd L.	Long	Accelerometer Kulite-GA(E)813	±150G
10	Crew Sta., Fwd L.	Lat	Accelerometer Kulite-GA(E)813	±50G
11	Crew Sta., Fwd R.	Vert	Accelerometer Kulite-GA(E)813	±150G
12	Crew Sta., Fwd R.	Long	Accelerometer Kulite-GA(E)813	±150G
13	Crew Sta., Fwd R.	Lat	Accelerometer Kulite-GA(E)813	±50G
14	Crew Sta., Rear L.	Vert	Accelerometer Kulite-GA(E)813	±150G
15	Crew Sta., Rear L.	Long	Accelerometer Kulite-GA(E)813	±150G
16	Crew Sta., Rear L.	Lat	Accelerometer Kulite-GA(E)813	±50G
17	Crew Sta., Rear R.	Vert	Accelerometer Kulite-GA(E)813	±150G

TABLE I (Concluded)

TM CH	PARAMETER	DIRECTION	SENSING ELEMENT	
			MODEL	RANGE
18	Crew Sta., Rear R.	Long	Accelerometer Kulite-GA(E)813	±150G
19	Crew Sta., Rear R.	Lat	Accelerometer Kulite-GA(E)813	±50G
20	Vehicle C.G.	Vert	Accelerometer Kulite-GA(E)813	±150G
21	Vehicle C.G.	Long	Accelerometer Kulite-GA(E)813	±150G
22	Vehicle C.G.	Lat	Accelerometer Kulite-GA(E)813	±50G
23	Release, Rocket Firing and Impact		Accelerometer Humphrey	±10G
24	Vehicle Position	Pitch	Rate Gyro Humphrey	400 Deg/Sec
25	Vehicle Position	Roll	Rate Gyro Humphrey	400 Deg/Sec
26	Vehicle Position	Yaw	Rate Gyro Humphrey	400 Deg/Sec
27	Rate of Descent		Radar Altimeter Ryan 207B	0 - 30 fps
28	Rate of Descent		Radar Altimeter Ryan 207B	0 - 30 fps

ON-BOARD CAMERA LOCATIONS

1. Photosonics - 200 fps - Front probes and impact
2. Photosonics - 200 fps - Aft probes and impact
3. Photosonics - 200 fps - Recovery chutes opening
4. Photosonics - 200 fps - Rocket cluster firing

b. Radar Velocity Sensor - The purpose of the radar velocity sensor is to measure the vertical descent velocities, including impact velocity, and altitudes of the test vehicle at probe ground contact and during rocket burning. In order to verify the retrorocket concept, it must be shown that; when the vertical impact velocity is reduced to ten feet per second or less, the impact forces will be within human tolerance. Therefore, it is essential that the vertical velocity be established as accurately as possible. As can be seen in Table II, the radar velocity is very accurate in the ranges of interest of this program.

6.2 ON-BOARD CAMERA COVERAGE

Four 16mm, 200 frames/second cameras were installed on the test vehicle to record the following:

- a. One each, installed in the vertical position, looking up to cover parachute deployment.
- b. One each, installed in the vertical position, looking up to cover rocket cluster firing.
- c. Two each, installed in vertical position looking down to cover the extension of the four probes.

TABLE II
CHARACTERISTICS OF SINK RATE RADAR

Performance Characteristics

Velocity Range	0.2 to 35 ft/sec
Accuracy of Velocity Measurement	
• Square Wave Output	±0.05%
• DC Analog Output	±0.5 ft/sec
Response Time	
• Square Wave Output	Instantaneous
• DC Analog Output	0.1 second
Altitude Capability	0 to 30 feet
Accuracy of Reconstructed Altitude Profile	±0.1 ft

Electrical Characteristics

Type of System	CW Doppler
Transmitted Frequency	4.225 GHz ±0.05%
Transmitted Power	15 mw ±5 mw
Antenna Beamwidth (2 way)	40 degrees
Input Power	28 VDC, 11 watts max.
Outputs	
• Square Wave	2.5 volts peak to peak
• DC Analog	0 to 9 volts DC (0.25 V/fps)
MTBF (Calculated)	5700 hours

Physical Characteristics

Weight	4.5 pounds
Size	7.5 x 5.2 x 4.6 inches

AFFDL-TR-76-107
Volume I

6.3 AIR-TO-AIR CAMERA COVERAGE

Air-to-air photo coverage was provided by photographers in a UH-1N chase helicopter using two 16mm, 100 frames/second cameras and two 16mm, 64 frames/second cameras.

6.4 GROUND-TO-AIR CAMERA COVERAGE

Ground-to-air photo coverage was provided by using fixed site and mobile tripod-mounted cameras located at various stations on the drop zone.

6.5 SPACE POSITIONING

Askania cinetheodolites with exposure rates of from 1 to 5 frames/second were used to determine positions in space, rates of descent and true airspeed of the test vehicle.

SECTION III
TEST PROCEDURES AND RESULTS

The test program consisted of eight tests beginning with the static firing of the rocket motors, followed by ground functional tests of the system and progressing into the flight tests which culminated in the total system test including retrorocket firing. A summary of the tests and results is presented in Table III, and a detailed description is presented in the remainder of this section.

1. ROCKET CLUSTER STATIC FIRING TEST

A cluster of four rocket motors was tested on a thrust stand at the AF Rocket Propulsion Laboratory, Edwards AFB, California, to reaffirm the pressure/thrust vs time relationship of the motors. The purpose of the test was also to test the new 38° nozzle, to check the effect on the performance with four rockets clustered together, and to test the harness. The results of this test are covered in Volume II and Reference 4.

During this test the rocket motors were to be ignited by requiring the probe to extend, then contacting the probe tip which would cause the tip microswitches to close, initiate the electrical CDF initiator, detonate the CDF up through the safe-and-arm device, initiate rocket ignitors and then rockets. Applying 42 VDC input voltage to the probe failed to cause extension. The probe was removed and the electrical CDF initiator was fired directly.

TABLE III
TEST PROGRAM SUMMARY

TEST NO. DATE	CONFIGURATION	TEST CONDITIONS	SUMMARY OF RESULTS
1 3Jul73	Rocket Cluster	Test firing of rocket cluster on static test stand. Ignition to be initiated by probe extension.	Probe malfunctioned. Rocket ignited by initiator. Firing and pressure/thrust vs. time relationship satisfactory.
2 25Feb74	Complete System - vehicle, probes, sequencer, CDF lines - No rockets.	Static functional test. Vehicle was suspended from a crane to simulate helicopter pick-up.	System functioned in sequence at correct times except for: (a) one F-1B timer did not retract all the cable to pull pin from microswitch. Redundant, so switch did not stop sequence. Check determined wrong cable, which was too long, was installed.
3 21Mar75	Weighted tub, helicopter cable, parachutes and support, release, four-leg 30 ft. bridle system.	Helicopter pick-up, climb to 3000 ft., fly test patterns, descend, land at helipad.	Lift-off satisfactory, weighted tub stable, no problems.
4 24Mar75	Weighted tub, helicopter cable, parachutes and support, release, four-leg 30 ft. bridle system, dummy rocket cluster/confluence fitting.	Helicopter pick-up, climb to 3000 ft., released.	Helicopter cable snagged corner of parachute frame during lift-off, tilted support stand approximately 45° before cable released stand. Safe-and-arm device released early due to not being safetied. Tub released at 3056 ft., chutes deployed, tub stable, test satisfactory.
5 27Mar75	Test vehicle, helicopter cable and vehicle bridle system.	Helicopter pick-up, climb to 3000 ft., fly test patterns, check stability, descend and land.	Dynamics of the vehicle were excellent, no rotation, very stable.
6 22Jul75	Test vehicle, probe assemblies, instrumentation, on-board cameras, no CDF (Flashbulbs to indicate CDF firing), helicopter cable, dummy rocket cluster/confluence fitting, parachutes and support, vehicle bridle system, release fitting.	Helicopter pick-up, release at 2000 ft., all systems to function except CDF and rocket cluster.	During lift-off, nylon section of vehicle bridle system snagged right front probe assembly shearing probe from vehicle. Vehicle released at 1935 feet. Release and chute deployment normal. Probe assemblies did not rotate down or extend. Latching relay did not latch due to marginal power supply. Sequence system will be modified. Instrumentation satisfactory except no strain link or velocity sensor data due to shorts.

TABLE III (Concluded)

TEST NO. DATE	CONFIGURATION	TEST CONDITIONS	SUMMARY OF RESULTS
7 1Aug75	Same as Test #6 except modified sequencer.	Same as Test #6.	Lift-off very good. Released at 1978 feet. Release and chute deployment good. Four probes rotated down to vertical position, three extended. Left rear probe fired flashbulb on extension indicating "short" in system. Rockets would have fired if connected. One probe that did not extend had broken wire at connector.
8 17Oct75	Test vehicle with all subsystems including rocket motors.	Live retrorocket test. Release at 2000 ft., all systems.	During lift-off, helicopter out of position causing rocket cluster/confluence fitting to strike vehicle causing following damage: (1) rocket nozzle bent - minor, (2) rocket harness - minor, (3) actuated one F-1B timer, (4) sheared off RH antenna, and (5) loosened LH antenna connector. Release and chute deployment good. Probe rotated and extended before release. Rocket motors firing and impact satisfactory. No instrumentation or on-board cameras.

An electrical check of the malfunctioning probe did not reveal any discrepancy. The probe was disassembled and it was discovered that sharp edges on the spring chip (which locks and keeps the probe from extending) were cutting into the release pin such that the solenoid did not have enough force to extract the pull pin. All probes were returned to the contractor for modifications. The modification consisted of increasing the solenoid voltage from 42 to 60 VDC, removing the sharp edges of the spring chip, deburring the release pin and installing a teflon sleeve over the release pin where the spring chip contacts the release pin. Several of the probes were retested and all functioned satisfactorily.

2 FUNCTIONAL TESTS

2.1 STATIC FUNCTIONAL TEST

A static functional test was conducted on the test vehicle after all modifications were complete in order to functionally check all the subsystems. The high crane in the AFFDL static test building was used to pick up the test vehicle at the parachute harness fitting in order to simulate the vehicle hanging from a helicopter ready for release. All subsystems were functional so that the test sequence could be tested up to, but not including, rocket motor ignition.

The vehicle batteries were switched on to initiate the test. After power was switched on, which simulated switching on the probe arm switch in the helicopter, a lanyard was used to pull the pins out of the

microswitches S_1 and S_2 and actuate the F-1B timers for S_3 and S_4 . Actuating S_1 and S_2 microswitches locked the power circuit in so that it would remain active when the power line from the helicopter was disconnected as the test vehicle was being released. This circuit also actuated a four-second delay timer. At the end of four seconds the circuit to the probe line cutters was closed, actuating the cutters which permit the probe assemblies to rotate and lock in the vertical position.

The F-1B timers were set for thirteen seconds. At the end of this time, the timers pulled the pins from the S_3 and S_4 microswitches, closing the circuits that energize the probe solenoids to extend the probes. These circuits also initiated a five-second time delay that opened the power circuit at the end of five seconds so that there was no power in any sequence circuit at vehicle ground impact. Each probe was measured to determine the extension dimension. After a five-second delay the vehicle was lowered until all four probes made contact and the CDF lines detonated.

The system functioned in the correct sequence and at the correct times with the following exceptions:

- a. One F-1B timer did not retract all the cable and so did not pull the pin from the S_4 microswitch. Since S_4 was a redundant switch it did not result in a failure. A bench check determined that the wrong cable (three inches too long) was used on that timer.

- b. One of the probe assemblies did not rotate down to the locked position. It was determined that this assembly was damaged during transportation.

2.2 WEIGHTED TUB PICK-UP TEST

A weighted tub pick-up test was conducted to check lift-off of the parachutes and frame from the support stand, the dynamics of the weighted tub, and the dynamics of the helicopter cable and the parachute frame after the vehicle and parachutes had been disconnected. The configuration tested included the 60-foot steel helicopter cable with wiring harness, three recovery parachutes attached to the support frame, a 12-foot connecting nylon lanyard, the rocket harness connecting bar, the 30-foot tub bridle system (four legs) and the weighted tub. The system shown in Figure 13 was set up on the helipad, laid out in-line with the parachutes and support frame, placed up on the support stand, and the weighted tub placed on the aft end of a flatbed trailer. The test procedure was for the helicopter to lift the parachute and frame from the support stand, then pick up the weighted tub from the trailer, climb to 3000 feet, fly three test patterns over the drop zone, descend and return to the helipad. The weighted tub and parachutes would then be disconnected and the helicopter would fly with just the 60-foot cable and the parachute frame.

The lift-off of the parachutes and frame from the support stand was satisfactory. The legs of the support stand fell as designed. The lift-off of the weighted tub was satisfactory. During ascent and flying

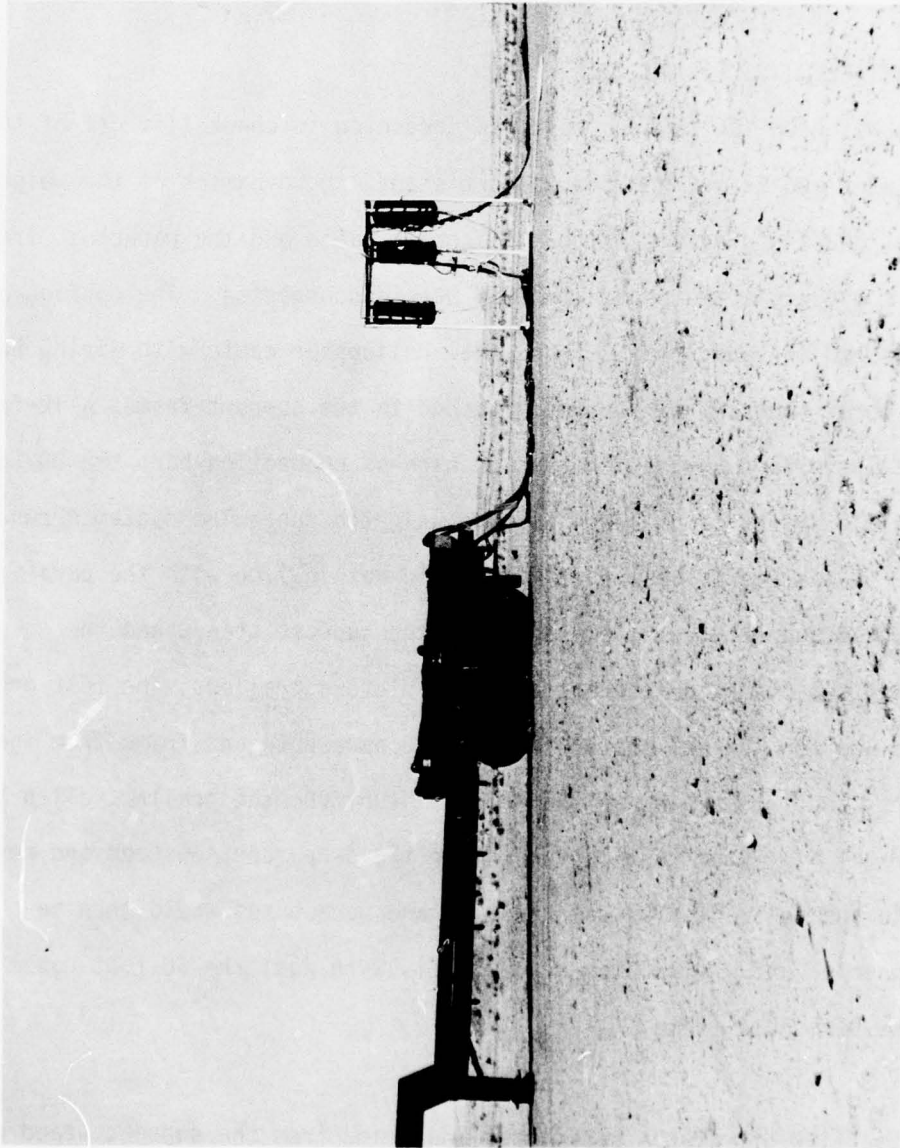

Figure 13. Weighted Tub Test Set-Up

the test patterns the weighted tub was very stable with very little rotation. Flying with just the cable and parachute frame was also satisfactory.

2.3 WEIGHTED TUB DROP TEST

This test was to again check the lift-off and dynamics of the system, and also to release the tub in order to check the functioning of the control box, the release and sequencing systems, parachute deployment and impact. The configuration was the same as Test #2 except the rocket cluster/confluence fitting with the release system was installed. Total lift-off weight was 8,180 pounds. The system was set up similar to the weighted tub pick-up test except the rocket cluster/confluence fitting was placed under the parachute frame in the center of the support stand. The weighted tub was positioned on the aft end of a flat-bed trailer.

The test procedure was for the helicopter to lift the parachute and frame from the support stand, which would be followed by lift-off of the rocket cluster/confluence fitting and then the pick-up of the weighted tub from the bed of the trailer. The helicopter would then climb to 3000 feet, fly one "dry run" pattern and then the test run. The weighted tub would be released at the center of the bull's-eye in the drop zone.

During lift-off, the helicopter cable snagged one corner of the parachute frame, lifting both the frame and the support stand until the support stand and rocket cluster/confluence fitting were leaning at

approximately a 45° angle. The parachute frame finally released from the support stand when one of the support stand fittings failed. Lift-off of the weighted tub was without incident. At approximately 200 feet above the ground during system ascent, the flashbulb, installed to indicate when the rocket safe-and-arm device was actuated, flashed indicating that the device was in the armed position. The only safety provided to keep this device from being actuated to the armed position was a metal clip that required approximately five pounds of force to release. The helicopter ascended to 3000 feet, made one dry run and released the weighted tub without incident on the test run. The parachutes' deployment, weighted tub stability, and impact were all satisfactory. See Figures 14 and 15.

2.4 VEHICLE PICK-UP TEST

The objective of this test was to check the lift-off and dynamics of the test vehicle. The test configuration included the 60-foot steel helicopter cable with wiring harness, the 12-foot connecting nylon lanyard, the rocket harness connecting bar, and the test vehicle with the bridle system. The vehicle was positioned on the helipad with the front end facing the helicopter. The bridle, lanyard, and steel cable were laid out in-line between the vehicle and helicopter. The test procedure was for the helicopter to pick up the vehicle, climb to 3000 feet, fly three test patterns, descend and then return to the helipad.

During pick-up, the test vehicle was dragged approximately two feet before it left the helipad; however, no damage resulted. The dynamics of the vehicle during flight were excellent with no rotation. The vehicle was very stable.

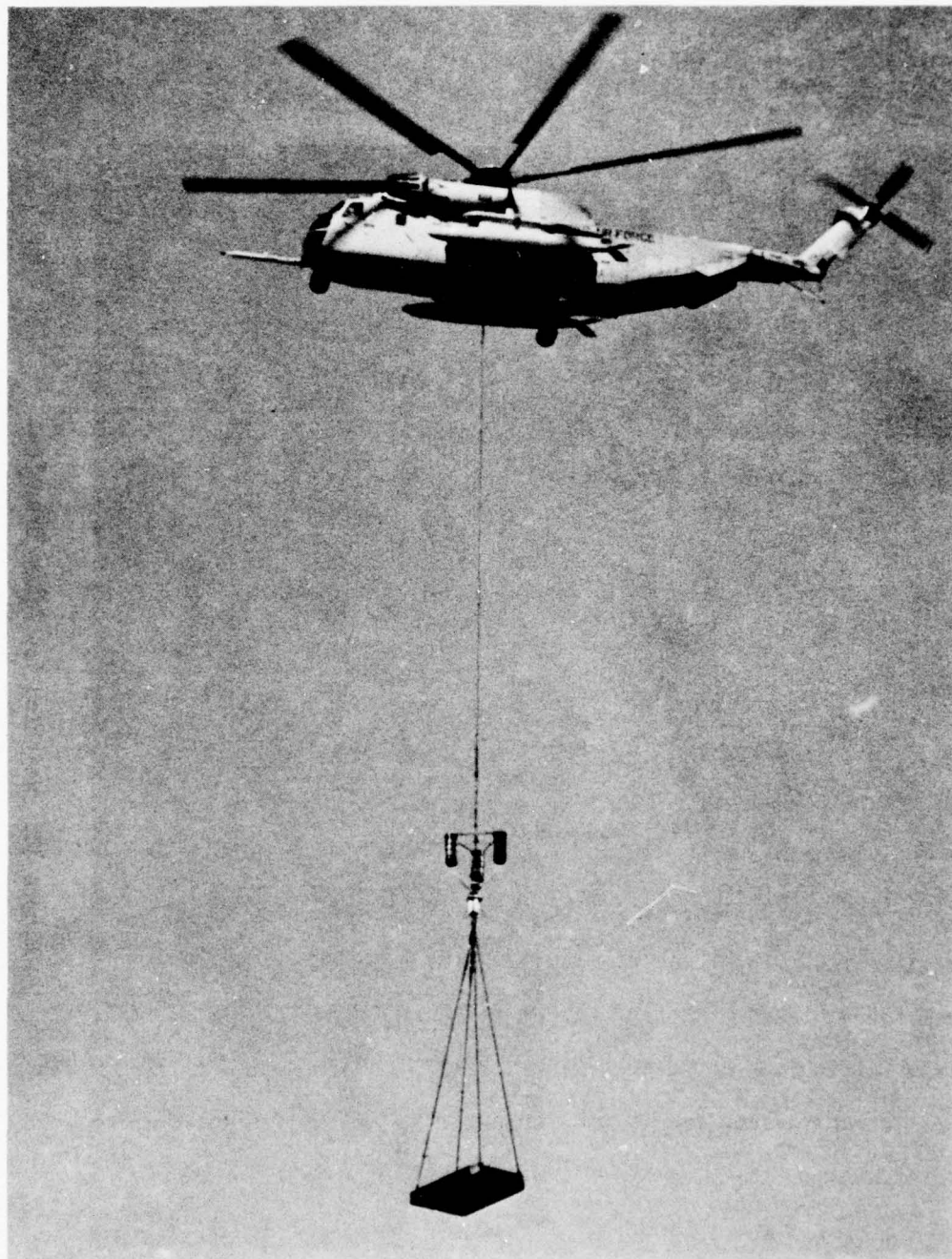

Figure 14. Weighted Tub After Pick-Up



Figure 15. Weighted Tub After Drop Test

AFFDL-TR-76-107

Volume I

2.5 VEHICLE FUNCTIONAL TEST #6

The objective of this test was to check the functioning of all systems (with the exception of the CDF lines and live rocket motors), instrumentation and on-board cameras. The test configuration consisted of the 60-foot steel helicopter cable with wiring harness, the three recovery parachutes and support frame, a 11.5-foot connecting nylon lanyard, the rocket cluster/confluence fitting, the bridle system and test vehicle. The test vehicle was complete with four probe assemblies, instrumentation package and four on-board cameras; one for parachute deployment, one for rockets and two for probe extension and impact. No CDF lines were installed; however, flashbulbs were installed so on impact the probes would fire the bulbs, indicating CDF line firing. A nine-foot diameter ring constructed of 3/4-inch conduct pipe was installed on the parachute support frame in order to prevent the helicopter cable from snagging the frame during pick-up as did happen during the previous test. Safety wire, in addition to the clip, was used to secure the safe-and-arm device in the safe position until the test vehicle was released from the helicopter. The sequencing system was also changed for this test. The purpose of this modification was to reduce the number of lanyard pull pin-actuated switches, ensure positive lock-in of power relay at time of release, and ensure proper event sequence. The new sequence, as shown in Figure 16, was as follows:

- a. Power Arm switched on - this switch controls power on the vehicle but does not "lock" it in.
- b. Release - this switch "locks" the power relay in and releases the vehicle.

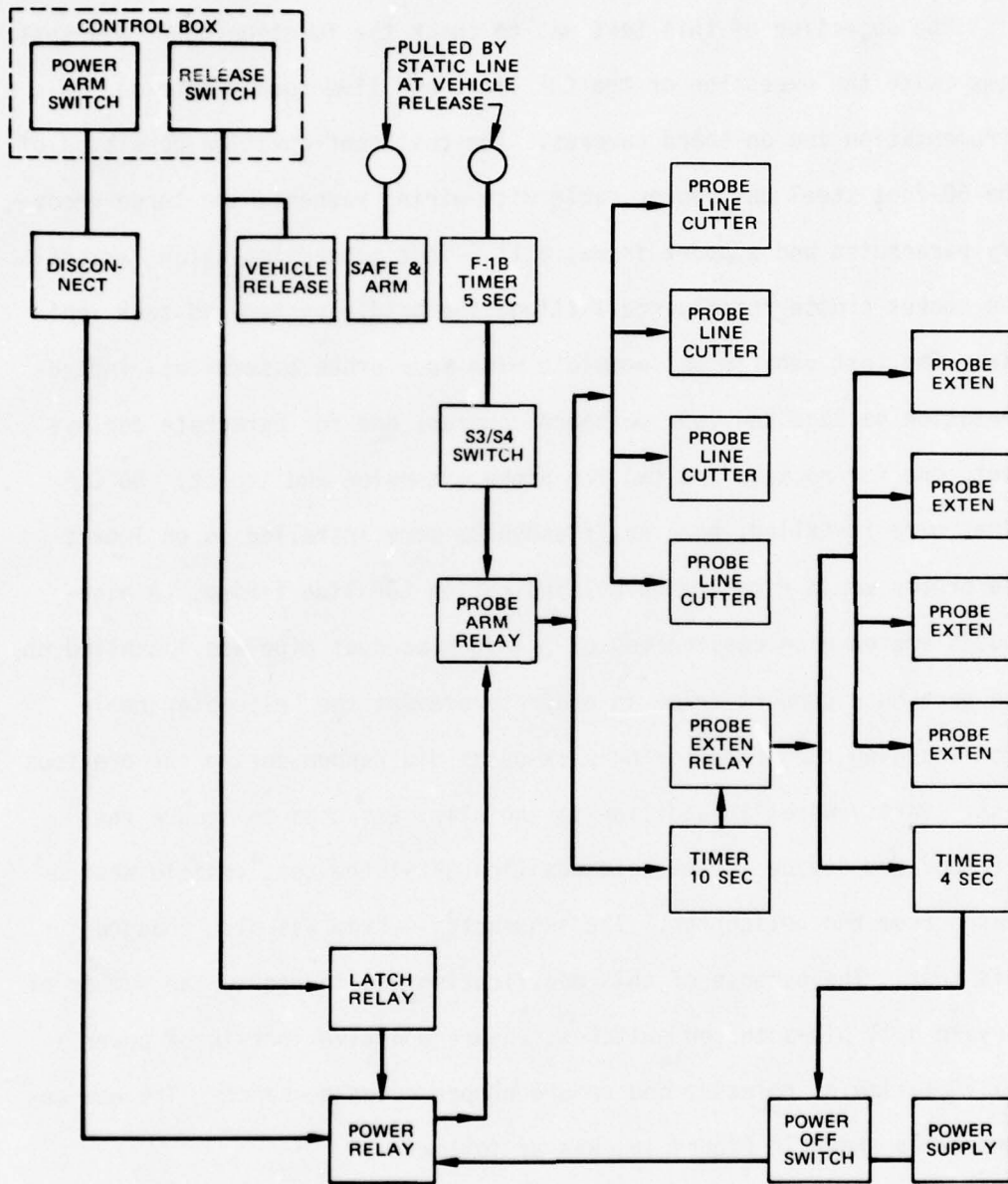

NOTE: RELEASE SWITCH WILL LATCH
 POWER RELAY-IN

Figure 16. Sequence System - First Modification

- c. At release the F-1B timers are actuated. The timers are set for five seconds which actuates S_3/S_4 switches which actuate the probe arm relay which then fires the probe line cutters to release the probe assemblies. The probe arm relay also starts a ten-second delay timer. This timer actuates the probe extension relay which then actuates the probe solenoids which release the probes.

The test vehicle was set up on approximately 12 inches of paper honeycomb material, front end facing the support stand. The remaining setup was the same as the weighted tub drop test. The test procedure was for the helicopter to lift the parachutes and frame from the support stand, followed by the rocket cluster/confluence fitting, and then pick up the test vehicle. The helicopter would then climb to 2000 feet, fly one "dry run" pattern and then the test run. The test vehicle would be released at the center of the bull's-eye in the drop zone.

During lift-off, the nylon lanyard section of the right rear leg of the bridle system snagged the right front probe attachment bracket. The vehicle tilted back until the extension on the aft of the vehicle impacted the ground; the bolts attaching the probe bracket to the vehicle sheared off, allowing the vehicle to return to the normal position. The helicopter continued to lift the vehicle until test altitude was reached. After a "dry run" the vehicle was released. Release and parachute deployment were normal. The probe assemblies did not rotate down or extend. A check of the system revealed that the latching relay was not latched. Tests indicated that the power pack for the helicopter control

AFFDL-TR-76-107

Volume I

box was marginal to fire the M-47 electrical ignitor for the vehicle release and to simultaneously actuate the latching relay. A decision was made to correct this problem by again modifying the sequencing system.

2.6 VEHICLE FUNCTIONAL TEST #7

This test was a repeat of Test #6. The test configuration was the same as Test #6 with the following exceptions:

- a. The sequence system was revised (see Figure 17) by removing the "power relay lock-in" from the release switch back to the power arm switch. The power arm switch controls the latching relay which controls the vehicle power for the sequence system. If the power arm switch is off, the system is safe even if an F-1B timer is actuated during lift-off. Nothing would happen until the switch was turned on, then the sequence would start.
- b. A quick release was installed on the safe-and-arm device so that the line to actuate the safe-and-arm does not have to break during separation.
- c. The vehicle was set up with the right-hand side facing the helicopter. The bridle system was bundled together and tied so that windblast would not whip a line, causing it to snag during lift-off. The bridle was also bundled together and tied on top of the vehicle so the strain links would remain in the correct position during lift-off.

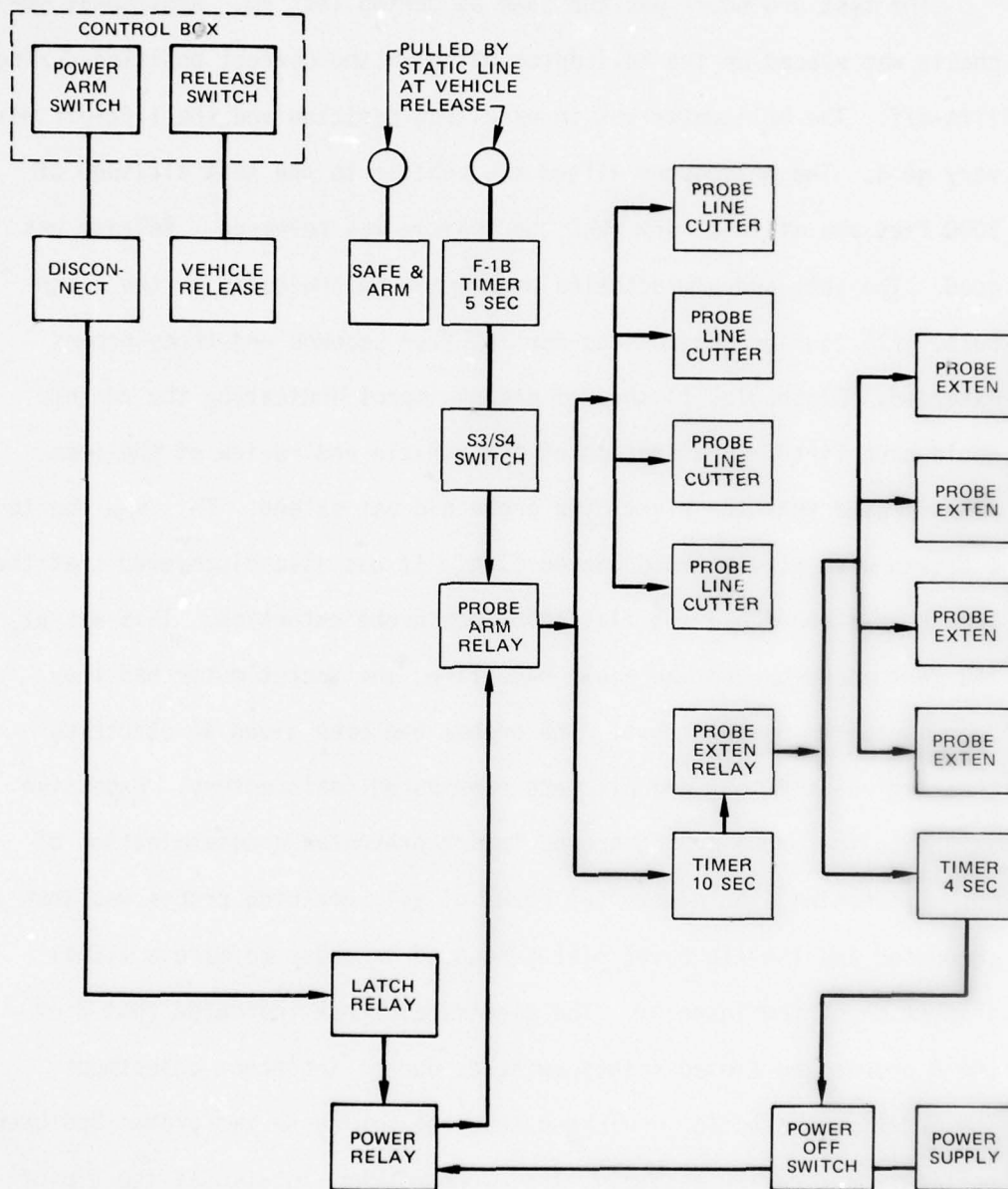

Figure 17. Sequence System - Final Modification

The test procedure was the same as during Test #6. Additional emphasis was placed on the helicopter being in the correct position during lift-off. The helicopter was in excellent position and the lift-off was very good. The helicopter lifted the vehicle to the test altitude of 2000 feet and after a "dry run" the vehicle was released. Release was good. The safe-and-arm actuated on release as indicated by the flashbulb. All four probes rotated down at five seconds and three probes extended. Flashbulbs flashed at probes impact indicating the rockets would have fired. Examination of the vehicle and review of the test films proved that the right-hand probe did not extend. This was due to a broken wire at the probe Cannon plug. It was also discovered that the left rear probe fired the flashbulb upon probe extension. This was at 750 feet above ground and would have fired the rocket motor had they been installed on this test. The probes had been given an electrical check before the test and all were considered satisfactory. Excessive damage to the probe during ground impact prevented a determination of the malfunction. An electrical check of all remaining probes was then conducted and the tip cover plates removed in order to make a visual inspection of the interior. The electrical check indicated that 3 of the 8 probes had closed safety switches due to incorrect adjustment. The interior inspection indicated that the wiring on two probes had been partially cut during assembly, two microswitches located at the tip of the probes were frozen in the open position but did start functioning after actuating them a number of times, and two were extrasensitive to actuation. One of the probes had both a closed safety switch and a tip switch that was initially frozen in open position and appeared to be extrasensitive to actuation after it was functioning correctly. A

AFFDL-TR-76-107
Volume I

decision was made to test this probe to see if the malfunction that occurred during the functional test could be duplicated. It was installed in the vertical position and a flashbulb was attached that would be actuated if the microswitches on probe tip were actuated. The probe was actuated; the flashbulb did not fire. An inspection of the probe indicated that the extrasensitive microswitch again froze such that the probe would not fire the rocket if it impacted the ground so as to just actuate that one microswitch. The probe extension was measured to be 76.25 inches instead of the required extension of $84 \pm .25$ inch. Overall, the probes were considered very unreliable; however, all steps had been taken to minimize the anticipated problems.

There were some problems with the instrumentation systems. The PAM telemetry with the accelerometers and rate sensors operated satisfactorily. The seven strain links again shorted out. The three parachute links and the rocket motor link were tied to one power source so that if there was a short in one of the links, it would short out all the other links connected to that power source. The other three links were connected to the bridle system and all were connected to another power source. Therefore, a short in one of the upper links and a short in one of the lower links would short out all seven links. The velocity sensor data was not satisfactory. The velocity sensor may have been damaged during one of the earlier tests; therefore, the spare unit was installed for the rocket test. The on-board cameras operated satisfactorily.

3. RETROROCKET TEST

The objective of this test was to demonstrate the impact attenuation retrorocket concept. The test configuration was the same as Test #7 except the CDF lines and live rocket motors were installed for this test. The sequencing as well as the test set-up (see Figures 18, 19, 20 and 21) was also the same as Functional Test #7. Lift-off weight was 8627 pounds. The helicopter cable, parachutes and support frame are not subjected to the rocket thrust; therefore, 8083 pounds was the weight to be decelerated by the rocket thrust.

The test procedure was for the helicopter to lift the parachutes and frame from the support, followed by the rocket cluster/confluence fitting, and then pick up the test vehicle. The helicopter would climb to 2000 feet, fly one "dry run" pattern and then the test run. The test vehicle would be released at the center of the bull's-eye in the drop zone (see Figures 22, 23, 24 and 25). The sequence should be as follows:

- a. Before release - the helicopter operator switches on the telemetry, the on-board cameras and the power arm switch, then releases the vehicle by pushing in the release switch.
- b. At release - the electrical cable is disconnected, the safe-and-arm device is actuated, the F-1B timers are actuated and the parachutes start to deploy.

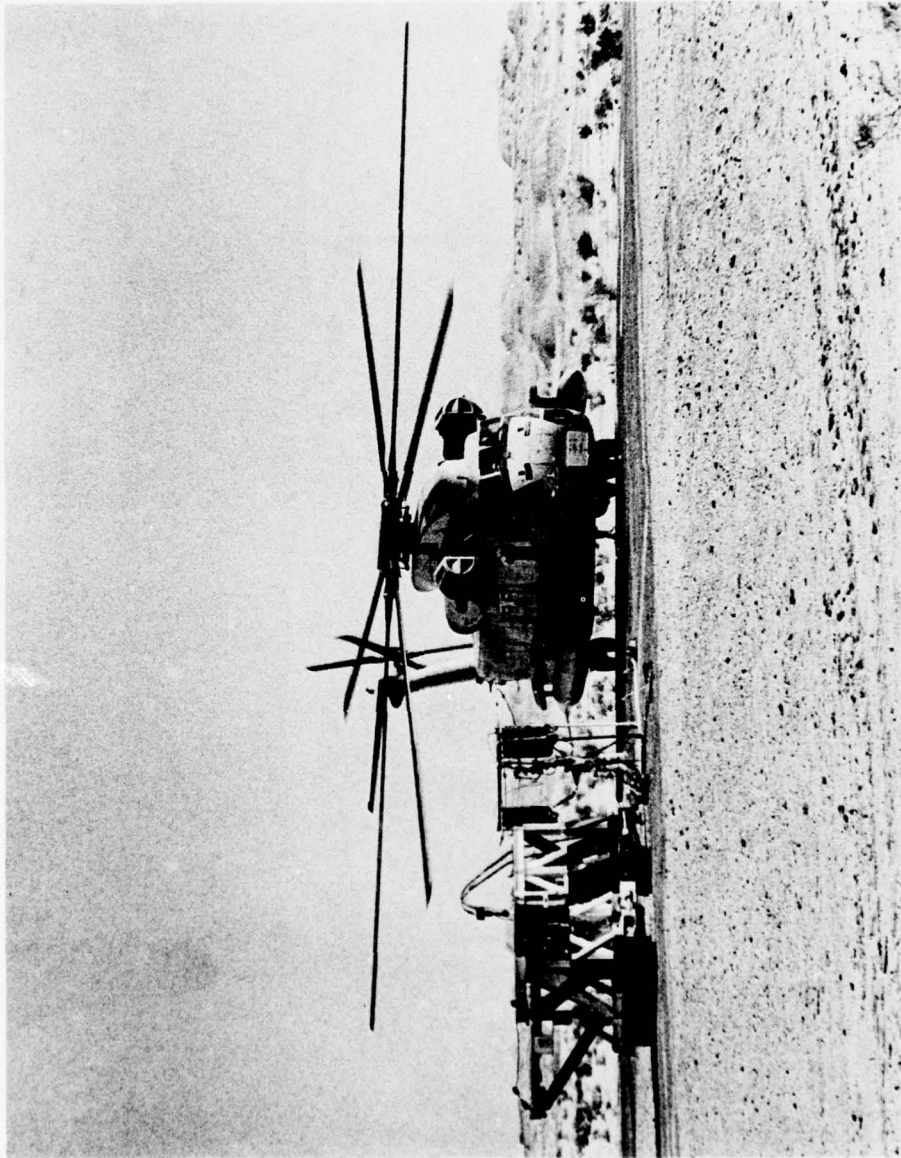

Figure 18. Vehicle Connected to Helicopter - Ready for Lift-Off

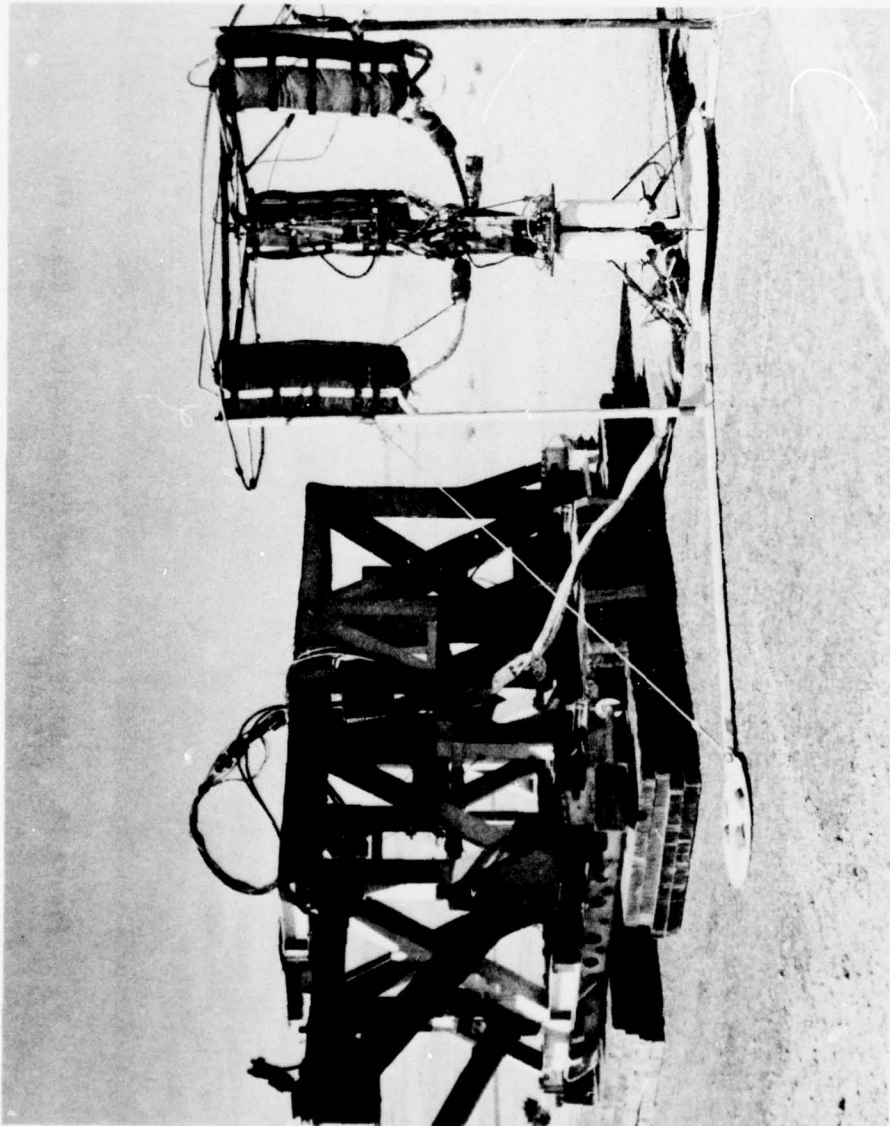

Figure 19. Vehicle and Support Stand

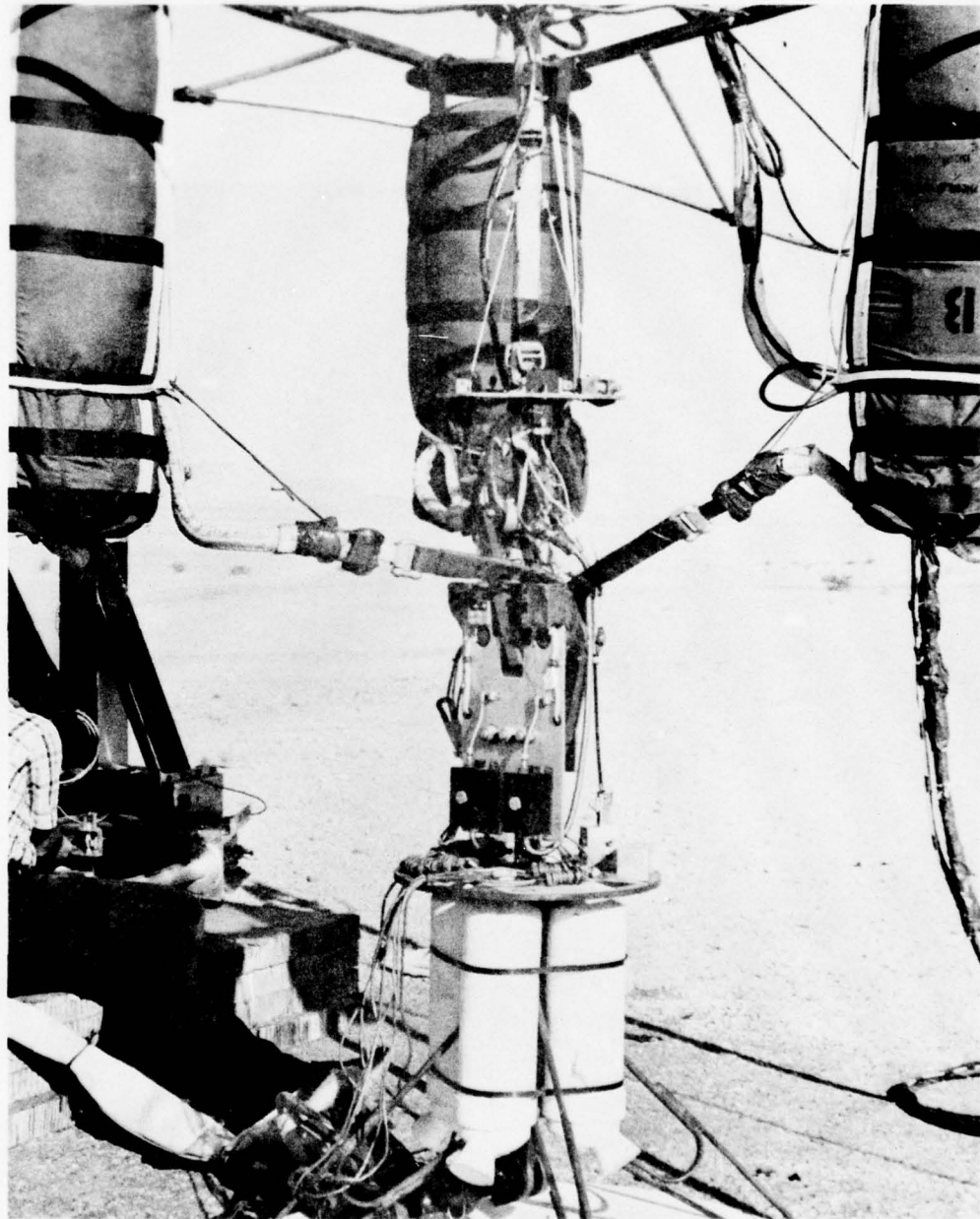

Figure 20. Rocket Cluster/Confluence Fitting

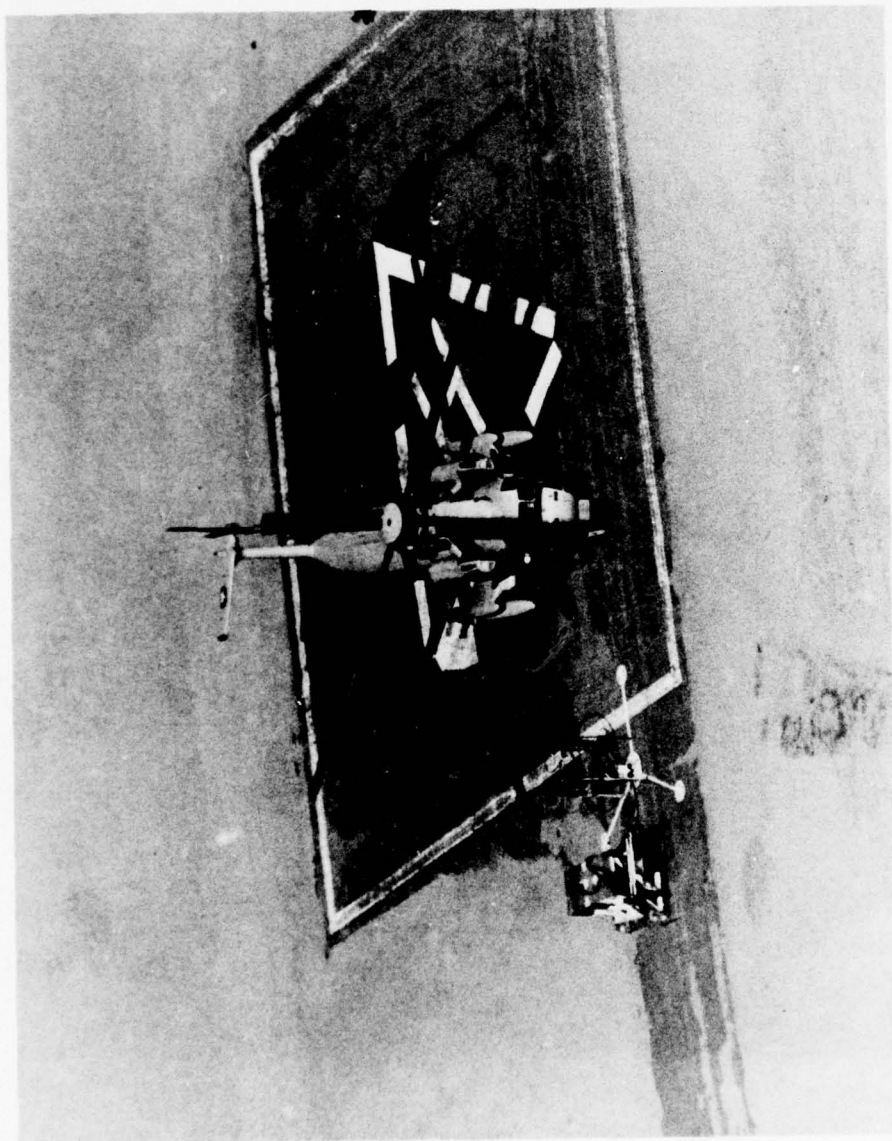

Figure 21. Helipad



Figure 22. Vehicle - Helicopter

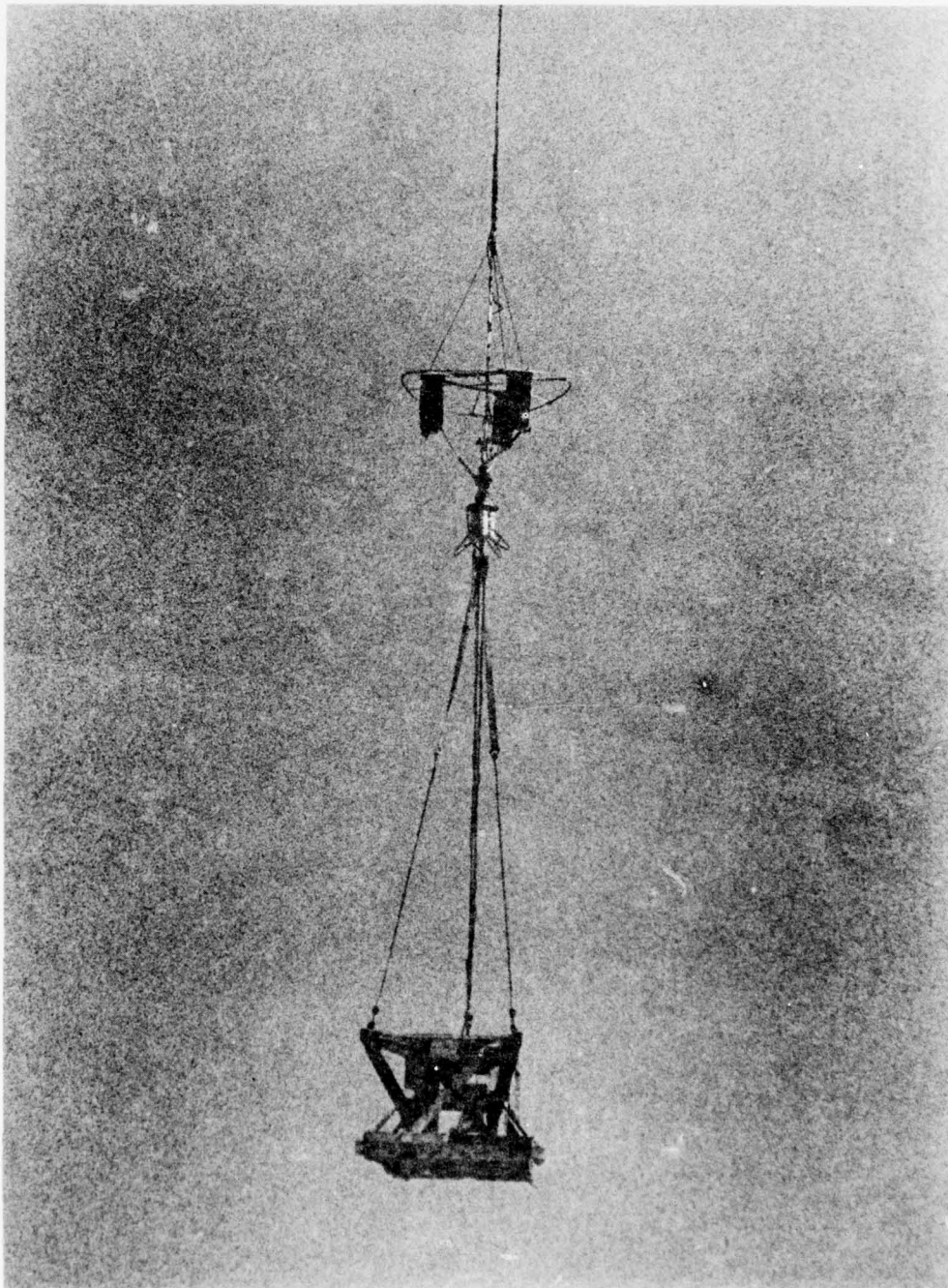

Figure 23. Vehicle Before Release

AFFDL-TR-76-107
Volume I

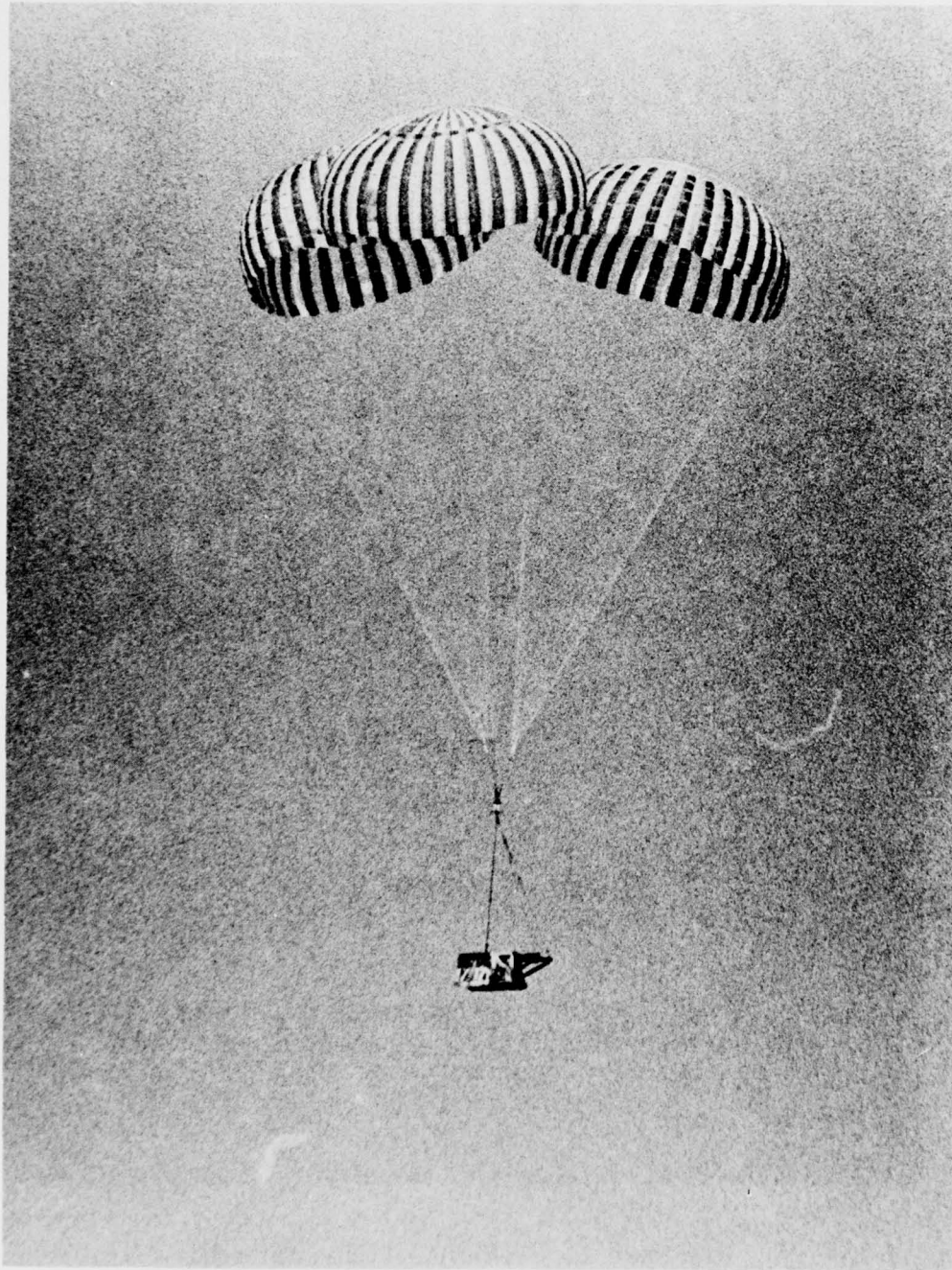

Figure 24. Vehicle - Full Chute Deployment

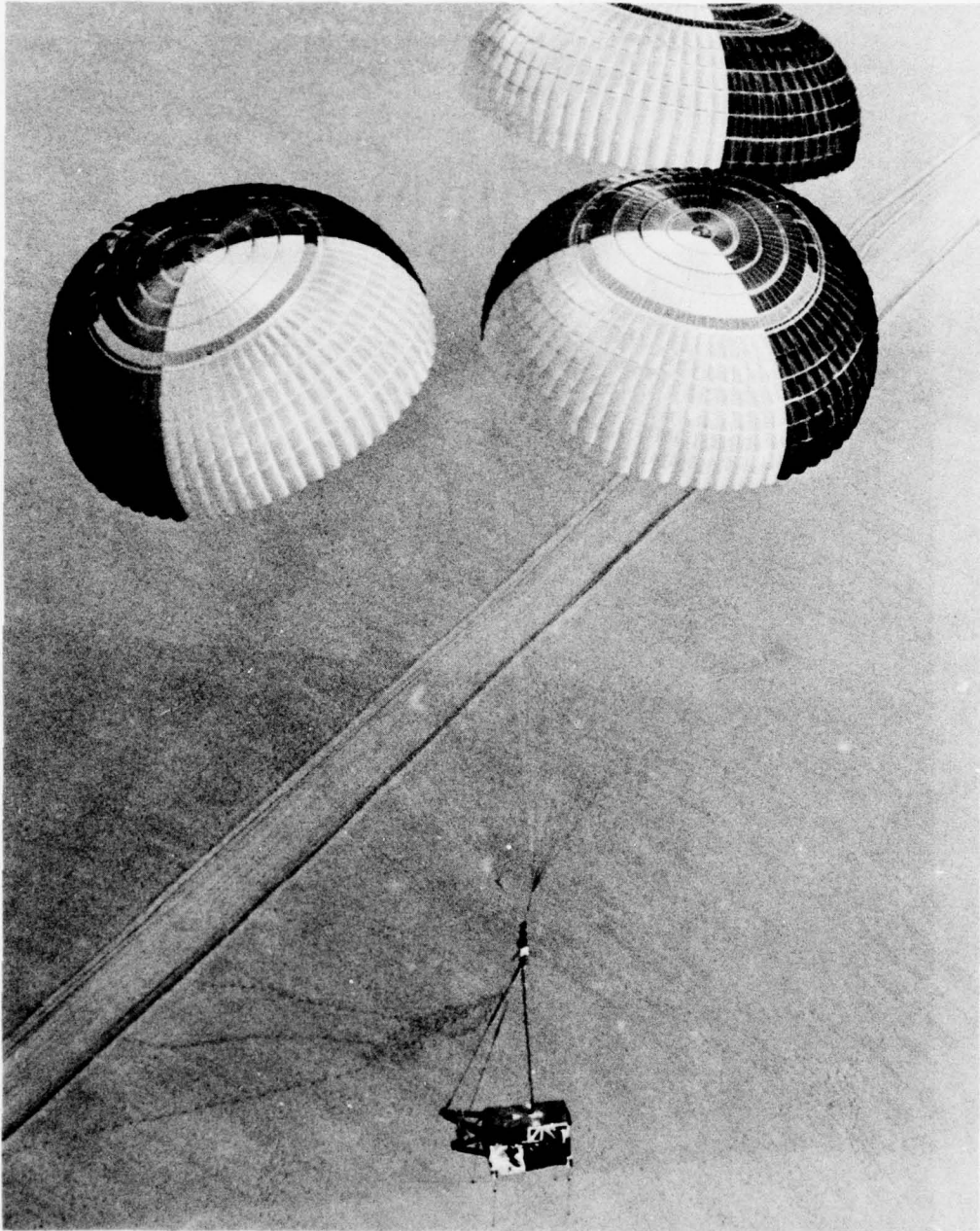

Figure 25. Vehicle - Probes Extended

AFFDL-TR-76-107
Volume I

- c. Five seconds after release - the F-1B timers extract the pin from the microswitch to close the switch to the probe line cutters. Cutting the lines allows the probe assemblies to fall free, rotate and lock in the vertical position. Closing this circuit activates another timer.

- d. Nine seconds after release - approximately three seconds after release, line stretch is reached in parachute deployment at which time the six-second time delay reefing line cutters are actuated so that at approximately nine seconds after release the reefing lines are cut, allowing the parachutes to fully inflate.

- e. Fifteen seconds after release - the ten-second delay timer closes the circuit to extend the probes. This also actuates a five-second delay timer that will open the vehicle power source circuit and remove all power from the sequence circuits. At approximately fifteen seconds, the parachutes are also fully inflated.

- f. Forty seconds after release - at approximately forty seconds after release, the probe tips impact the ground, firing the CDF initiator, the CDF lines and the rocket motors in turn. The rocket motors burn for approximately 0.4 second for maximum thrust and approximately 1.0 second for the sustainer thrust. The vehicle will impact the ground during sustainer burning or immediately thereafter.

During lift-off the helicopter drifted over the test vehicle before the parachutes/support frame and rocket cluster/confluence fitting were picked up. When the helicopter gained sufficient height to lift the parachutes/support frame off the support stand, the rocket cluster/confluence fitting swung into the test vehicle causing the following damage:

- a. Bent one rocket nozzle - minor, did not affect performance of the rocket motor.
- b. Bent top support ring for the rocket motors - minor damage.
- c. Snagged cable housing of one of the F-1B timers, actuated the timer.
- d. Sheared off the instrumentation antenna on right-hand side of the vehicle.
- e. Loosened the antenna connection on the left-hand side of the test vehicle.

The decision to continue the lift-off had been made early in the program. It was decided that if the vehicle was lifted off the ground the test would proceed since it would be very difficult, if not impossible, to set the parachutes/support frame and rocket cluster/confluence fitting back down on the ground without causing damage to the rocket motors, deploying parachutes or possibly firing the rocket motors.

The helicopter ascended to 2000 feet without further incident. When the test monitor switched on power arm, the probe cutters were actuated immediately and the probes extended ten seconds later, even before the vehicle was released. This was due to the F-1B timer being actuated during lift-off. The release, parachute deployment, rocket firing and final impact were satisfactory (see Figure 26).

Shearing off one instrumentation antenna and a loose connection on the other antenna resulted in the loss of all instrumentation data. The on-board camera data was also lost due to a malfunctioning switch. Data was obtained by the air-to-air and ground-to-air photo coverage and the phototheodolite coverage. Analyses of the photo coverage, phototheodolite coverage and meteorological information provided the following test data:

Ambient Temperature	84°F
Wind Velocity	6 knots/300°
Slope of Impact Area	0°
Descent Velocity	29.5 ft/sec
(based on the average velocity during last five seconds before rocket ignition)	
Release Altitude	2096 feet
Chutes Vehicle Oscillation Angle	2°
Release	Elapsed time 0
Line Stretch	2.908 seconds
Full Open	15.508 seconds

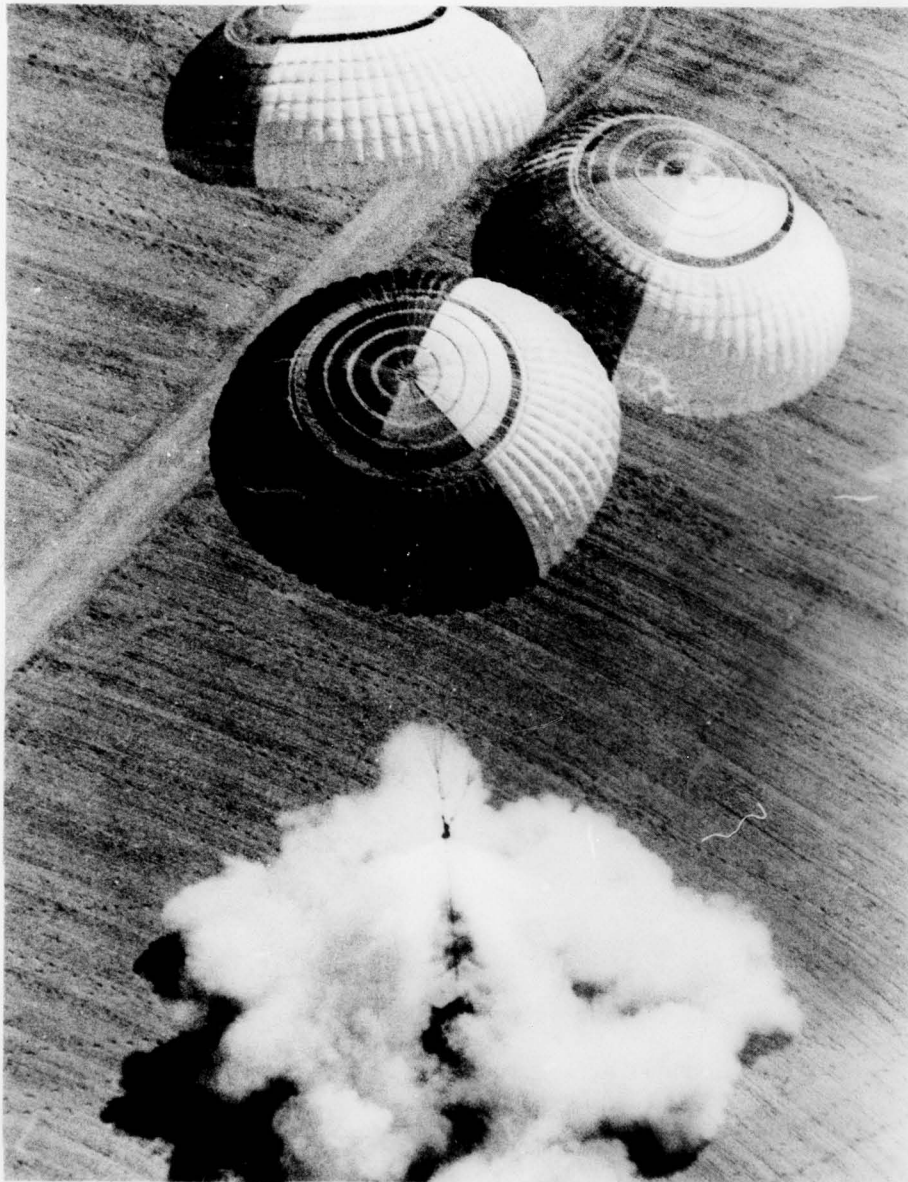

Figure 26. Rocket Firing

AFFDL-TR-76-107
Volume I

Probes Impact	41.230 seconds
Rocket Ignition	41.308 seconds
Vehicle Impact	41.788 seconds
Probe Impact to Vehicle Impact	.558 second

Using the above data and the results of the rocket performance computer program in Volume II, it was determined that the vehicle impacted at a velocity of 9.59 ft/sec. This was below the goal of 10 ft/sec impact velocity; therefore, the impact forces should have been within human tolerances.

SECTION IV
CONCLUSIONS

1. The retrorocket system is capable of reducing the velocity of a crew escape capsule from a 30 fps parachute descent velocity to 10 fps at ground impact.
2. Verification of predictions that the 10 fps or lower ground impact velocity will result in landing loads within currently established physiological limits was not accomplished.
3. The rigid mechanical altimeter (probe) design used in this program is unsatisfactory from a reliability standpoint as evidenced by the many failures and design deficiencies uncovered during the test program.
4. Development of the retrorocket system to the point where the technology can be confidently applied to an operational system program will require an extensive test and evaluation program.

REFERENCES

1. Peterson, R. L., Roberts, E. O., "Experimental Investigation of the Ground Impact Characteristics of a Full-Scale Aircraft Emergency Escape Capsule System," AFFDL-TR-72-34, July 1972.
2. Rockwell Corp. Presentation to USAF/ASD, "B-1 Impact Attenuation System," June 1972.
3. Military Specification MIL-C-25969B (USAF), "Capsule Emergency Escape Systems, General Requirements For," 4 March 1970.
4. AF Rocket Propulsion Laboratory Technical Report, AFRPL-TR-74-32, Final Report, "Crew Escape Module Retrorocket Motor," September 1974.
5. Anon., "A Study to Select Optimum Attitude Sensing Devices," Sylvania Report No. A58-4-5.0-17, 2 Volumes, May 1963 (Prepared for NASA, Houston, Texas, Contract No. NAS 9-1098).

APPENDIX A
IGNITION HEIGHT ERROR AND PROBE
LENGTH CALCULATIONS

The retrorocket ignition height is the height of the bottom surface of the escape capsule above the earth surface at the moment of retrorocket ignition. The ignition height is a function of the ground sensing probe length (PL), the attitude of the capsule, the ground slope, capsule rate of descent, and energy transmission and rocket ignition system characteristics. The maximum ignition height was established by the computer analysis to be 8.1 ft. Using the design goal of ± 0.5 ft. for ignition height error, the nominal ignition height is 7.6 ft. and the minimum ignition height is 7.1 ft. Using the nominal ignition height and the parameters mentioned above, a probe length and actual ignition height error range are calculated for the demonstration program conditions. The procedure is an interactive one and an initial probe length of 9.0 ft. is assumed. (See attached sketch.)

A. CAPSULE ATTITUDE

E = Error due to attitude, slope,
time delay and variations.

$$E = PL (1 - \cos \theta) \quad \theta = \text{Oscillation Angle}$$
$$= 9.0 (1 - \cos 10^\circ) = 0.137 \text{ ft.} = 1.64 \text{ in.}$$

B. GROUND SLOPE

$$E = PL (\tan \gamma)(\sin \theta) \quad \gamma = \text{Ground Slope}$$
$$= 9.0 (\tan 1^\circ)(\sin 10^\circ) = 0.027 \text{ ft.} = 0.32 \text{ in.}$$

C. PROBE EXTENSION VARIATION

$$E = \pm 0.25 \text{ in. (Specified)}$$

D. PROBE RESPONSE TIME VARIATION

$$E = \Delta t(V) \quad \Delta t = 0.003 \text{ sec. (Specified)}$$

$$\begin{aligned} \text{For } V = 31.3 \text{ ft/sec} \quad E &= 0.003(31.3) = 0.0939 \text{ ft} \\ &= 1.13 \text{ in.} \end{aligned}$$

$$\begin{aligned} \text{For } V = 24.7 \text{ ft/sec} \quad E &= 0.003(24.7) = 0.0741 \text{ ft} \\ &= 0.89 \text{ in.} \end{aligned}$$

E. CDF BURN TIME DELAY

$$E = \frac{L}{BR} (V)$$

$$L = \text{CDF Length} = 59 \text{ ft.}$$

$$\begin{aligned} BR &= \text{CDF Burn Rate} = 20,000 \text{ ft/sec} \\ &(\text{Specified}) \end{aligned}$$

$$\begin{aligned} \text{For } V = 31.3 \text{ ft/sec} \quad E &= \frac{59}{20,000} (31.3) = 0.0923 \text{ ft} \\ &= 1.11 \text{ in.} \end{aligned}$$

$$\begin{aligned} \text{For } V = 24.7 \text{ ft/sec} \quad E &= \frac{59}{20,000} (24.7) = 0.0728 \text{ ft} \\ &= 0.87 \text{ in.} \end{aligned}$$

F. RETROCKET IGNITION DELAY AND DELAY VARIATION

Ignition delay is 0.035 seconds \pm 0.010 seconds.

1. DELAY

$$E = \Delta t V$$

For 31.3 ft/sec $E = 0.035(31.3) = 1.0955 \text{ ft}$
 $= 13.15 \text{ in.}$

For 24.7 ft/sec $E = 0.035(24.7) = 0.864 \text{ ft}$
 $= 10.37 \text{ in.}$

2. VARIATION

$$E = \Delta t V$$

For 31.3 ft/sec $E = 0.010(31.3) = 0.313 \text{ ft}$
 $= 3.76 \text{ in.}$

For 24.7 ft/sec $E = 0.010(24.7) = 0.247 \text{ ft}$
 $= 2.96 \text{ in.}$

SUMMATION OF DELAYS AND DELAY VARIATIONS IN INCHES

	<u>DESCENT RATE = 24.7 FT/SEC</u>		<u>DESCENT RATE = 31.3 FT/SEC</u>	
	<u>MAX DELAY</u>	<u>MIN DELAY</u>	<u>MAX DELAY</u>	<u>MIN DELAY</u>
A	1.64	0	1.64	0
B	0.32	0	0.32	0
C	0.25	-0.25	0.25	-0.25
D	0.89	0	1.13	0
E	0.87	0.87	1.11	1.11
F ₁	10.37	10.37	13.15	13.15
F ₂	2.96	-2.96	3.76	-3.76
	_____	_____	_____	_____
	17.30	8.03	21.36	10.25

Fixed Delay = 8.03 in. = 0.67 ft. (FD)

Error Range = (21.36 - 8.03) in. = 13.33 in. (ER)

Error = $\pm 13.33/2 = \pm 6.66$ in. = ± 0.56 ft. (E)

PROBE LENGTH CALCULATION

$$PL = IH \text{ nom} + E + FD = 7.6 + 0.56 + 0.67 = 8.83 \text{ ft.}$$

Reiteration of the PL calculation using 8.83 ft. changes the value of A to 1.61 in. (B remains 0.32 in. and the other values C → F are not involved). This changes the error range to 21.33 - 8.03 = 13.30 in. and E = ± 0.55 ft. PL then becomes 8.82 ft.

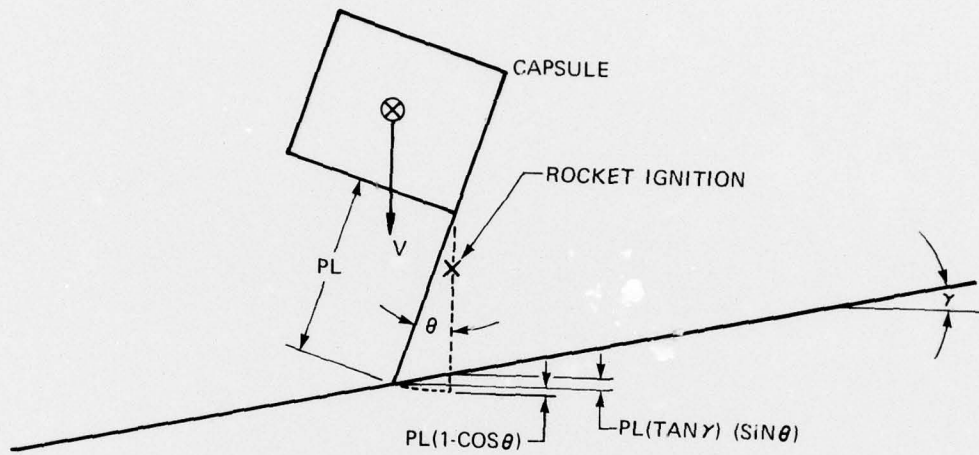

θ = OSCILLATION ANGLE
 γ = GROUND SLOPE ANGLE
 V = CAPSULE DESCENT RATE