

AD-A042 377

LOCKHEED-GEORGIA CO MARIETTA
INVESTIGATION OF ELECTRO-HYDRAULIC PULSE MOTORS FOR AIRCRAFT UT--ETC(U)
MAY 77 E W RUMRILL, F D LEWIS

F/G 1/3

F33615-75-C-2005

UNCLASSIFIED

LG77ER0099

AFAPL-TR-77-14

NL

1 OF 2
ADA
042377



ADA 042377

AFAPL-TR-77-14

12 J

INVESTIGATION OF ELECTROHYDRAULIC PULSE MOTORS FOR AIRCRAFT UTILITY FUNCTIONS

LOCKHEED-GEORGIA COMPANY
A DIVISION OF LOCKHEED AIRCRAFT CORPORATION
MARIETTA, GEORGIA 30063

DDC
AUG 3 1977
C

MAY 1977

TECHNICAL REPORT AFAPL-TR-77-14
FINAL REPORT FOR PERIOD 3 FEBRUARY 1975 - DECEMBER 1976

Approved for public release; distribution unlimited

AD No. _____
DDC FILE COPY

AIR FORCE AERO-PROPULSION LABORATORY
AIR FORCE WRIGHT AERONAUTICAL LABORATORIES
AIR FORCE SYSTEMS COMMAND
WRIGHT-PATTERSON AIR FORCE BASE, OHIO 45433

NOTICE

When Government drawings, specifications, or other data are used for any purpose other than in connection with a definitely related Government procurement operation, the United States Government thereby incurs no responsibility nor any obligation whatsoever; and the fact that the government may have formulated, furnished, or in any way supplied the said drawings, specifications, or other data, is not to be regarded by implication or otherwise as in any manner licensing the holder or any other person or corporation, or conveying any rights or permission to manufacture, use, or sell any patented invention that may in any way be related thereto.

This report has been reviewed by the Information Office (ASD/OIP), and is releasable to the National Technical Information Service (NTIS). At NTIS it will be available to the general public, including foreign nations.

This technical report has been reviewed and is approved for publication.

Kenneth E. Binns
KENNETH E. BINNS, Project Engineer
Fluid and Mechanical Systems
Vehicle Power Branch

FOR THE COMMANDER:

Stephen P. Condon
STEPHEN P. CONDON, Major, USAF
Chief, Vehicle Power Branch
Air Force Aero Propulsion Laboratory

ADDITIONAL INFO	
NTIS	Write Section <input checked="" type="checkbox"/>
DDC	Buff Section <input type="checkbox"/>
UNANNOUNCED	<input type="checkbox"/>
JUSTIFICATION.....	
BY.....	
DISTRIBUTION/AVAILABILITY CODES	
DTIC	AVAIL. AND/OR SPECIAL
A	

Copies of this report should not be returned unless return is required by security considerations, contractual obligations, or notice on a specific document.

UNCLASSIFIED

SECURITY CLASSIFICATION OF THIS PAGE (When Data Entered)

REPORT DOCUMENTATION PAGE		READ INSTRUCTIONS BEFORE COMPLETING FORM
1. REPORT NUMBER 18 AFAPL-TR-77-14	2. GOVT ACCESSION NO.	3. REPORT'S CATALOG NUMBER 9 (rept.)
4. TITLE (and Subtitle) 6 Investigation of Electro-Hydraulic Pulse Motors for Aircraft Utility Functions	5. DATE OF REPORT & PERIOD COVERED Final 3 February 1975 to December 1976	
7. AUTHOR(s) 10 Edwin W. Rumrill, Jr. Frank D. Lewis	8. PERFORMING ORG. REPORT NUMBER 14 LG77ER0099	9. CONTRACT OR GRANT NUMBER(s) Contract 15 F33615-75-C-2005
9. PERFORMING ORGANIZATION NAME AND ADDRESS Lockheed-Georgia Company 86 South Cobb Drive Marietta, Georgia 30063	10. PROGRAM ELEMENT, PROJECT, TASK AREA & WORK UNIT NUMBERS 16 62203F 31458020 12 307	11. CONTROLLING OFFICE NAME AND ADDRESS Air Force Aero-Propulsion Laboratory/POP Wright-Patterson AFB, Ohio 45433
12. REPORT DATE December 1976	13. NUMBER OF PAGES 145	14. MONITORING AGENCY NAME & ADDRESS (if different from Controlling Office) 12 147p. 11 May 77
15. SECURITY CLASS. (of this report) Unclassified	15a. DECLASSIFICATION/DOWNGRADING SCHEDULE	
16. DISTRIBUTION STATEMENT (of this Report) Approved for public release; distribution unlimited.		
17. DISTRIBUTION STATEMENT (of the abstract entered in Block 20, if different from Report)		
18. SUPPLEMENTARY NOTES		
19. KEY WORDS (Continue on reverse side if necessary and identify by block number) Hydraulic Motor Servo Motor Pulse Motor Digital Control Motor Stepper Motor Electro Hydraulic Pulse Motor		
20. ABSTRACT (Continue on reverse side if necessary and identify by block number) The purpose of this electrohydraulic pulse motor (EHPM) technology-development project was to investigate feasibility and applicability and demonstrate capability of the EHPM concept for mating the power of hydraulics with the "intelligence" of the digital computer for use in future aircraft utility systems. Recent dramatic developments in electronic circuit manufacturing necessitates the review of control concepts for the purpose of redefining the optimum mix of technologies. The significant reduction in cost, size, and weight and increase in reliability of digital computers offers the potential for performing the bulk of		

DD FORM 1473 1 JAN 73 EDITION OF 1 NOV 65 IS OBSOLETE

UNCLASSIFIED

SECURITY CLASSIFICATION OF THIS PAGE (When Data Entered)

210 065

1B

UNCLASSIFIED

SECURITY CLASSIFICATION OF THIS PAGE(When Data Entered)

control functions within the electronic circuit in lieu of the hydraulic circuit. The EHPM concept is highly compatible with this concept, but existing units are used in machine tools and are not configured to achieve maximum power and minimum weight as needed for aircraft use.

In this program the designs of EHPM's for aircraft use was investigated; an EHPM was designed and constructed using an aircraft type hydraulic motor; an input system consisting of a micro computer, an interface board, input and output position encoders, an electric pulse motor (EPM) driver, and a software program was designed and constructed; the EHPM and the input system were tested as components and as a system; the system was used to control the C-5 iron bird flap system with simulated loading; the EHPM unit was subjected to a durability test; and a survey of various aircraft subsystems where the EHPM could be a viable alternative was accomplished.

Testing revealed several problems with the current design, but all problems were considered to be correctable with state-of-the-art techniques.

The concept is considered to be a viable alternative approach to utility and secondary flight control systems, and the principal payoff will be improved reliability and maintenance cost.

UNCLASSIFIED

SECURITY CLASSIFICATION OF THIS PAGE(When Data Entered)

PREFACE

The work reported here was performed by the Lockheed-Georgia Company, A Division of Lockheed Aircraft Corporation, Marietta, Georgia, under Air Force Contract F33615-75-C-2005, "Investigation of Electro-Hydraulic Pulse Motors for Aircraft Utility Functions." The Air Force Project Manager was Mr. Kenneth E. Binns and the Lockheed Project Manager was Mr. Edwin W. Rumrill.

Special acknowledgements for their technical efforts in the program are awarded to the following Lockheed engineering personnel:

- Mr. Frank D. Lewis, Technical Assistance
- Mr. Al J. Kascak, Software Development
- Mr. David R. Bell, Electronic Circuit Development
- Mr. Vaughn Watson, Testing Assistance
- Mr. J. M. McCarty, Technical Assistance

TABLE OF CONTENTS

SECTION	PAGE
SUMMARY	x
I. INTRODUCTION	1
II. ANALYTICAL STUDY	2
III. APPLICATION SURVEY	38
IV. PROTOTYPE EHPM DESIGN	41
V. PROTOTYPE FABRICATION	62
VI. PROTOTYPE EHPM TESTING	65
VII. CONCLUSIONS AND RECOMMENDATIONS	107
APPENDIX A GLOSSARY OF TERMS	110
APPENDIX B INPUT CONTROL SYSTEM DESCRIPTION	115
REFERENCES	136

LIST OF ILLUSTRATIONS

<u>FIGURE</u>	<u>TITLE</u>	<u>PAGE</u>
1	Available Stepper Motors Characteristics	3
2	Performance Comparison of Available Stepper Motors	4
3	Specifications for ICON (Fujitsu) Hi - PM Series	5
4	Simplified Stepping Motor Control System	8
5	Organization of Microcomputer	10
6	Family of Holding Torque Curves	13
7	Pullout Torque vs. Pulse Rate for Fujitsu Hi - PM0	13
8	Acceleration and Deceleration Performance for Fujitsu Hi - PM0	15
9	Hydraulic Motors, Displacement and Speed	17
10	Hydraulic Motor Speed & Flow Characteristics	18
11	Typical Valving Surfaces Hydraulic Motor	20
12	Balanced Spool Valve Configurations	22
13	Motor/Valve Matching	24
14	Valve Basic Dimensions	26
15	Valve Flow Forces	28
16	Valve Torque Calculations	30
17	Valve Torque	31
18	Closed Loop EH Servo System	34
19	Open loop EHPM System	34
20	Closed Loop EHV Servo Vs. Open Loop EHPM	35

LIST OF ILLUSTRATIONS (CONT'D)

<u>FIGURE</u>	<u>TITLE</u>	<u>PAGE</u>
21	C-5 Trailing Edge Flap Schematic	42
22	Flap Load Vs. Deflection	43
23	Flap System Data	44
24	System Arrangement for Prototype Testing	45
25	Hydraulic Motor, Abex Model No. AM8C-2	47
26	Hydraulic Motor Performance	48
27	Electrohydraulic Pulse Motor	49
28	Valve Flow Vs. Displacement	52
29	S-Plane Root Loci, Hydraulic Servo System	54
30	Open Loop Frequency Response	54
31	Candidate Step Motor Speed-Torque Characteristics	55
32	Speed-Torque Characteristic, ICON Hi - PMO Step Motor	57
33	Outline Drawing - Hi - PMO Stepper Motor	60
34	Abex Drawing of EHPM	63
35	Input Control System	66
36	Test Arrangement of Input Control System	67
37	Input Drive and EPM Breadboard Test Arrangement	68
38	Test Arrangement for Measuring Pull Out Torque of EPM	70
39	EPM Pull Out Torque	71
40	Test Arrangement for Valve Drag Torque Measurements	73

LIST OF ILLUSTRATIONS (CONT'D)

<u>FIGURE</u>	<u>TITLE</u>	<u>PAGE</u>
41	Test Area for Drag Torque Tests	74
42	Valve Flow Gain Characteristics	75
43	Valve Pressure Drop with 27 GPM Flow Rate	75
44	EHPM Assembly	76
45	Functional (Performance) Test Arrangement	77
46	Test Area for EHPM Assembly Tests	78
47	Non-Linear Acceleration Ramp Compared with Formalized Curves	80
48	Iron Bird Test Arrangement	82
49	Iron Bird Test Arrangement - Flap System	83
50	C-5 Iron Bird Flap and Loading Mechanism	84
51	C-5 Iron Bird Flap Gear Box Before Modification - Left Side	85
52	C-5 Iron Bird Flap Gear Box and Control Before Modification, Right Side	86
53	Iron Bird Flap Gear Box After Modification - Left Side	87
54	Iron Bird Flap Gear Box After Modification - Right Side	88
55	Iron Bird Test Operator Station	89
56	EHPM Performance on C-5 Iron Bird with Hydraulic Ground Cart with No Decel Program	91
57	EHPM Start-Stop Performance on C-5 Iron Bird with Maximum Loading	92
58	EHPM Full Cycle Performance on C-5 Iron Bird with Partial Loading	94
59	Response of EHPM to Load Exceeding System Capacity	94

LIST OF ILLUSTRATIONS (CONT'D)

<u>FIGURE</u>	<u>TITLE</u>	<u>PAGE</u>
60	Evaluation of EHPM at Various Levels of Flow Inadequacy	96
61	Durability Test Set Up	97
62	Summary of Durability Cycling	99
63	Durability Flow Tests	100
64	Valve Spool Showing Material Voids	102
65	The EPM Disassembled	103
66	The EHPM Disassembled	104
67	Valve Drag Torques	106
B-1	CPU Diagram	116
B-2	Microcomputer Instruction Set	117
B-3	ICON 601-T Driver	118
B-4	Wiring Diagram	119
B-5	Schematic Diagram of Interface Board	121
B-6	Program Printout	125
B-7	Iron Bird Flap Control Flow Chart	129
B-8	C-5 Iron Bird Flap Drive Program	131

SUMMARY

The electrohydraulic pulse motor (EHPM) presently being used for machine tool control offers an effective interface between the "intelligence" of the low power digital computer and the "strength" of high power hydraulics. The machine tool systems, however, are not suitable for aircraft because of weight, cost, and volume. Advances in electronic circuit technology are leading to values which will make the input concept a viable approach for aircraft utility and secondary flight control systems. The EHPM device needs adapting to aircraft use to achieve the horsepower to weight values for aircraft hydraulic drives, and the purpose of this program was to develop an aircraft EHPM.

Existing EHPM technology was investigated including the state-of-the-art of the electrical pulse motor (EPM) - a key element of the concept. Potential uses in aircraft utility and secondary flight control systems were studied. A prototype EHPM and a breadboard input system using an Altair 8800 microcomputer were designed, constructed, and tested.

Testing consisted of bench tests, iron bird testing wherein the system was used to drive the C-5 flap simulator with simulated loading, and durability testing.

Several problems were encountered with the prototype unit; the EPM torque is insufficient for the design, and full speed was not achieved in one direction; the design is sensitive to return pressure but can be altered to reduce the sensitivity; failure of the plating on the spool apparently caused a seizure of the spool; sleeve retainment was not adequate; and non-jamming thread stops need to be used on the drive threads.

All of the problems encountered are considered to be correctable by redesign. Additionally it was concluded that for aircraft purposes a pilot concept wherein the EPM drives a very small pilot valve which hydraulically positions the main valve can be more appropriate than the direct drive. This approach allows use of a smaller EPM and EPM drive circuit. Reduction of speed between the hydraulic motor and the valve will allow the EPM to operate at lower speeds on a higher level of its torque curve. Resolution reduction is no obstacle as existing EHPM resolution exceeds aircraft requirements by several orders of magnitude.

The EHPM concept is considered to be a viable alternative approach to utility and secondary flight control systems especially where multiple actuators require synchronizing. The principal payoff is expected to occur in improved reliability and maintenance costs due to a significant reduction in the quantity of moving parts.

SECTION I INTRODUCTION

Toward the goal of providing lighter, less costly, and more reliable aircraft actuation systems, electro-hydraulic pulse motors (EHPM) offer the promise of a logical interface between the airborne digital computer and the loads carried by large hydraulic power actuation systems. The practical application of an EHPM system is made possible by recent advances in electrical circuitry and control technology.

In Japan and Europe, the "stepper" was adapted to openloop control of machine tools, after extensive use of electrical stepping motors in data processing and instrumentation equipment. When it appeared that needed acceleration rates could not be achieved, the electrical stepper was mated with the hydraulic motor to increase driving torque, and the EHPM was created. Preliminary analysis indicates a promising future for the application of EPHM to aircraft systems. It is a highly attractive concept for mating the power of hydraulics with light weight low cost electronic control circuits and the "intelligence" of the digital computer. Although the initial EHPM's have been used successfully in the machine-tool industry to control motion in exacting machine operations, the existing hardware is not suitable for aircraft use. Constraints of weight, volume, duty cycle, and environment will not allow aircraft use of machine-tool industry developed units.

The current program is aimed at evaluating and adapting the EHPM for control and power of aircraft utility systems. The program performs a preliminary analysis of available equipment and the interfaces of the various components of EHPM actuation system including the input control system, the pulse motor, control valve and hydraulic motor. A prototype EHPM was built and tested to drive a flap actuation system controlled by a digital input control system.

SECTION II ANALYTICAL STUDY

State-of-the-Art and Available Hardware Survey

The EHPM - The Reference 1 magazine article entitled, "Guide-to-Performance and Specifications of EHSM's", is a treatment of the state-of-the-art. It provides a chart comparing the performance of units which are produced by six manufacturers. Fujitsu units are nearest to aircraft requirements with models utilizing 2,000 psi and involving speeds to 4,000 RPM. Sizes available from Fujitsu are in the power range of 0.8 to 20 horsepower. Since aircraft hydraulic motors operate at higher speeds and pressures to achieve minimum weight, the optimum arrangement, as will be noted later in the design section, must involve a gear reduction between the electrical stepping motor (EPM) and the hydraulic motor.

The Electrical Stepper Motor (EPM) - The electrical pulse motor is a critical component of the EHPM package. The hydraulic valve and the hydraulic motor present no critical design problems except as pertains to reducing the torque and speed required of the electrical pulse motor. A key effort in developing the EHPM to aircraft use is to obtain an electrical pulse motor or an arrangement that will permit use of the hydraulic motor up to its maximum capability. As a first step in this task, a survey of available steppers was conducted. The Manufacturer's Chart, Figure 1, represents the result of this survey. Parameters chosen for inclusion in the chart are intended to convey a "quick look" at stepper capability.

The "Baloney" Chart, Figure 2, reproduced from Reference 2 article, summarizes the state-of-the-art for stepper motors in regard to the speed versus torque characteristics. Selection of hardware, requires the use of in-depth performance data which are appropriately provided on curves provided by the supplier.

Figure 3 illustrates a manufacturer's presentation of specification for a line of stepper motors. The series presented is the Fujitsu HI-PM line and the HI-PM 0 is the selected unit for the test program. While data were gathered on many other manufacturers and on various hybrid types such as "flexspline", "synstep", and "nutating gear", the charts represent data on only those units which appear to offer performance close to that required for driving an EHPM; i. e., the top performers for torque and RPM which are believed to represent the best state-of-the-art. The two types of units in the chart are Variable Reluctance (VR) and Permanent Magnet (PM) types. These two types offer appropriate characteristics for use in aircraft EHPM's, including mechanical simplicity, high RPM, and low weight.

An important difference in stepper performance needs for aircraft applications and conventional applications lies in the area of resolution and shaft speed. Most uses require a small step but a high step rate. In the machine tool applications, a small increment of control is necessary, and one step is used to cause a motion of .0001 inch. A step rate of 20,000 pulses/second offers a tool translation maximum rate of

Manufacturer	Motor Type	# of Frame Sizes	Steps per Second at Zero Load Torque		Maximum Slew Rate	Pulse to-Step Fidelity	Step Size (deg.)	Accuracy (deg.)	Peak Holding Torque (oz. in.)	Rotor Inertia (gcm ²)	Voltage Rating
			VR	PM							
Computer Devices (Rapid/Syn)	VR	8-23	18	500-15,000	400-2,000	2.25-15	0.06-0.45	1.0-50	0.18-350	6-28	
	PM	8-34	40	180-2,000	175-1,100	1.8-90	0.05-2.7	0.8-500	0.3-1,850	2-35	
Eastern Air Devices	VR	20	6	2,000-6,000	450-650	-15	-	35-65	10-20	-28	
	PM	23-34	10	500-20,000	300-950	-1.8	-	70-265	120-1,100	2-35	
IMC Magnetic (Tormax)	VR	8-25	24	375-6,000	350-1,050	7.5-15	+0.2-+0.4	0.35-110	0.1-15	5.5-28	
	PM	5-34	24	150-30,000	105-900	1.8-90	+0.05-+1.0	0.25-60	0.19-400	5.5-48	
Novatronics (Muirhead)	VR	8-23	8	680-2,560	80-1,012	1.8-15	0.05-0.75	0.2-22	0.18-3.8	6-28	
	PM	8-23	22	90-1,200	70-720	1.8-90	0.05-4.5	0.65-53	0.7-187	6-28	
Sigma	PM	9-20	90	150-10,000	-2,000	0.72-22.5	+0.05-+0.90	1.0-1,000	0.6-11,000	2-48	
Singer Kearfott	VR	8-40	24	-	120-2,000	1.8-90	0.05-2.5	0.5-175	0.28-110	28	
	PM	8-40	11	-	100-390	1.8-90	0.05-2.5	0.3-22	0.26-23	28	
Superior (Slo-Syn)	PM		100	-20,000	-5,000	0.72-1.5	+0.05-+0.09	53-2,100	0.03-2.75	1.3-28	
USM ICON (Fujitsu)	VR		6	-16,000	-2,600	1.2-4.5	-0.67	30-480	34-1,356	Varies with drive circuitry	
Warner	VR	20-60	50	3,000-16,000	300-1,300	1.8-15	+0.09-+0.33	30-1,100	8.47-5,380	1.2-28	

Figure 1 Available Stepper Motor Characteristics

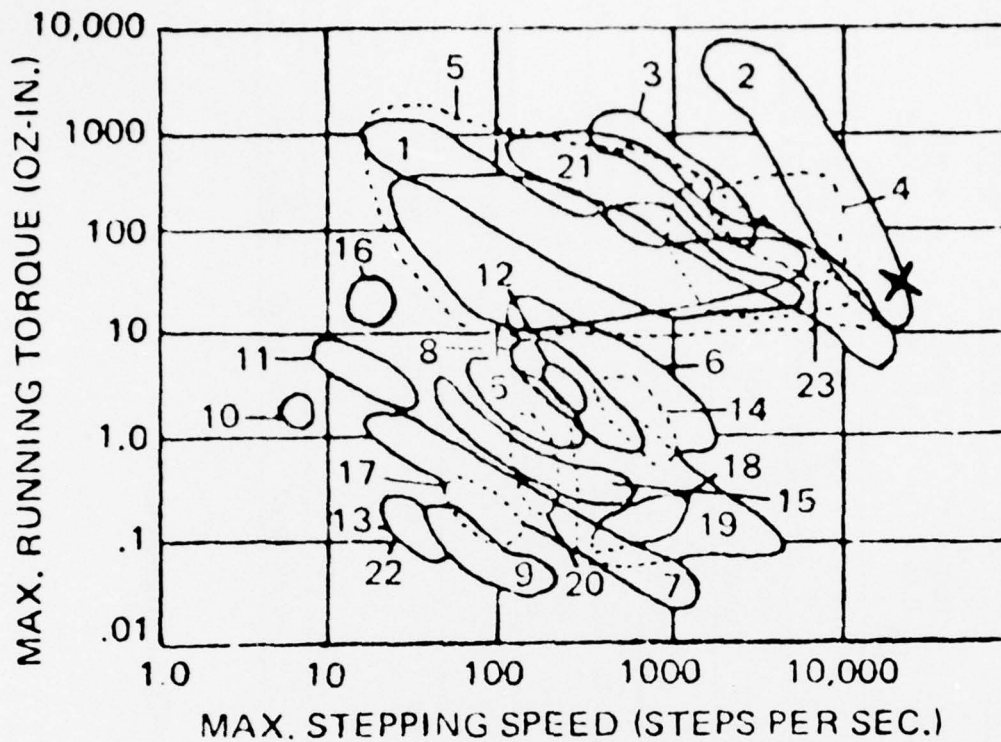

Key:

- | | |
|-----------------------------------|--|
| (19) American Electronics, Inc. | (15) IMC Magnetics |
| (14) Automation Development Corp. | (11) Ledex, Inc. |
| (9) Bowmar Instrument | (23) MesurMatics Electronics |
| (20) Cedar Engineering Co. | (12) Muirhead Instruments, Ltd. |
| (24) Computer Devices | (13) North American Philips Controls |
| (7) Clifton Precision Products | (5) Sigma Instruments, Inc. |
| (21) Dahmen-Burnett Electronics | (1) Superior Electric Co. |
| (8) General Precision (Kearfott) | (3) USM Corp. |
| (16) Giannini | (18) Vernitron Corp. |
| (22) Haydon Switch & Instrument | (4) Warner Electric Brake & Clutch Co. |
| (10) Heinemann Electronics | (17) Weston Transicoil Div. |
| (2) Icon Corp. | (6) Wright Machinery Co. |

Figure 2 Performance Comparison of Available Stepper Motors from Electromechanical Design, Reference 2

Kinds		Hi. PMs (High Pulse Motors)									
Item	Motor Type	Hi. PM 0	Hi. PM 5	Hi. PM 10	Hi. PM 20	Hi. PM 30	Hi. PM D				
Angular Increment per Pulse	deg.	1.2	1.5	1.5	1.2	1.2	0.36				
Maximum Running Pulse Rate	pps	16,000	16,000	16,000	16,000	16,000	16,000				
Output Power (Approximate) HP			class A	class B	class A	class B	class A	class B	class A	class B	
		0.13	1.5	0.8	2.5	1	3	1.5	3.5	2	3
Output Torque (kg. cm (oz. in))			30	30	70	70	100	100	150	150	330
		2.5 (35)	(420)	(420)	(970)	(970)	(1,400)	(1,400)	(2,100)	(2,100)	(4,600)
at 100pps											
		4	27	22	60	45	82	67	115	100	275
		(55)	(370)	(310)	(830)	(630)	(1,150)	(930)	(1,600)	(1,400)	(3,800)
at 8,000pps											
		3	25	15	50	20	65	35	80	50	220
		(42)	(350)	(210)	(700)	(280)	(900)	(490)	(1,100)	(690)	(3,050)
at 16,000pps											
Allowable Load Inertia	kg. cm. sec ² (lb. in. sec ²)	4x10 ⁻⁴ (3.5x10 ⁻⁴)	1x10 ⁻² (0.8x10 ⁻²)	10 ⁻² (3.5x10 ⁻²)	4x10 ⁻² (3.5x10 ⁻²)	8x10 ⁻² (6.9x10 ⁻²)	4x10 ⁻¹ (3.5x10 ⁻¹)				
Rotation Accuracy (Maximum Cumulative Errors)	(step)	±0.2	±0.2	±0.2	±0.2	±0.2	±0.2				
Approximate Weight	kg (lb)	3	14	28	40	60	60				
		6.6	30.8	61.6	88	132	132				

Figure 3 Specifications for ICON (Fujitsu) Hi - PM Series

2 inches/second or 120 inches/minute. In aircraft applications, it is reasonable that one pulse can represent a much larger displacement, such as three orders of magnitude greater, but the speed requirements for hydraulic motors are also higher. A 300 pulse/rev stepper, stepping at 20,000 pulses/second provides 4,020 RPM. This RPM capacity, important to aircraft applications, is not reflected directly in the Figure 1 Characteristic Chart but may be calculated as follows:

$$\text{RPM} \left(\frac{\text{revs}}{\text{min}} \right) = 60 \frac{\text{PPS (Pulses/Second)}}{\text{PPR (Pulses/Revolution)}}$$

Stepping motor technology has initiated a new language which must be introduced in order to apply the technology. Some selected terminology is provided in the section on stepper motors and in Appendix A.

Input Control System - As previously stated, the advancement in the state-of-the-art of electronic circuit manufacturing is a prime factor that makes this program applicable. Complex control functions can be handled with standard circuit modules at low cost and weight and with good reliability offering the potential for removing control functions from the hydraulic system where the hardware is heavy, specialized, and involves complex mechanical moving parts subject to interactions, seizing, leakage, etc. As an example, it often requires from 7 to 10 hydraulic valves to control a utility actuation system in "bang-bang" fashion whereas the EHPM concept offers control with one valve, and performance is optimized by control of acceleration/deceleration and speed at any position of the load. The capability to free the system of pressure surges and to alter performance characteristics by means of software changes in the computer in lieu of valve hardware changes are attractive considerations. The fact that additional input parameters can be read into the control functions usually at low cost per parameter and at various stages of system development is an important plus for the concept. Although this program is directed toward the development of the EHPM, it is technology advancement in the input control that makes it feasible.

The input control system consists of two basic control units 1) The microcomputer and 2) The stepper motor drive circuits. Microcomputers are available in many sizes and capabilities and standard microcomputers may be used for development of EHPM input controls. The stepper motor drive circuits are designed and developed for the particular design of the stepper motor and are available from the stepper motor manufacturer. Development of EHPM input control systems can utilize these standard microcomputers or stepper motor drive circuits, however final application of the control system may package the complete input control system in a single unit. A more complete discussion of these important control units follows in component analyses and in Appendix A.

Component Analysis

Input Drive Systems - An EHPM is basically a device that transforms a stream of low power electrical pulses into high power mechanical motion such that the total travel is proportional to the quantity of pulses, the rate is proportional to the frequency of the pulses, and acceleration is proportional to change in frequency of the pulses. The input control system must, therefore, read a signal from the crew, or some automatic

control which calls for a position and rate of an actuated device. It can also "read in" other control parameters such as status of other systems or aircraft performance data. It must interpret these signals, transform them into a stream of pulses which are acceptable to the EHPM, and deliver them in the correct rate and quantity. The input control signals need to be at low power levels except where high power is required into the stepping motor.

The block diagram of Figure 4 illustrates the elements of a simple input control system. Elements A, B, and C are low power circuits in order to utilize advance technology Large Scale Integration (LSI) circuit modules. These elements transform the input commands into the required pulse frequency and quantity and select the proper coil(s) of the EPM to energize. Element D amplifies the signal to the coil(s) being energized to the power level required by the EPM. Element E of Figure 4 can be used to sense when the regime for successful open loop control is about to be exited. A new regime can be entered and the system operated at reduced speed. Element E can also be used to operate the system strictly closed loop.

Elements A and B (containing the microcomputer) control the input signal into the sequential logic element which is a stream of pulses upon which the EPM responds on a one-to-one basis. Control of the pulse stream to achieve direction, displacement, ramping, reaction to any feedback, or any control function will have been performed before the stream reaches the sequential logic element. It is, therefore, the function of the "front" elements, which are defined as those between the crew and the sequential logic element, to control the pulse timing, i.e., frequency and change in frequency; the quantity of the pulses; and to select the line on which to put the pulses to apply forward or reverse rotation. The elements of the input system up to the sequential logic element can be of various configurations and the appropriate approach is a strong function of the system application; i.e., input and output complexity; number of channels; flexibility requirements; and projected growth or uncertainty for change. For the purpose of this study, however, the most flexible and the highest state-of-the-art which utilizes the standard LSI module approach -- digital computer control -- is of prime interest and the program is geared to this approach. There are several microcomputers on the market which can perform the required function of this portion of the input system. The packaging of these off-the-shelf units is not representative of ultimate aircraft packaging, however, the circuit elements are representative and on a functional basis, this hardware is appropriate for the program. It is noted that final packaging of the input system was specifically excepted as an objective for the program.

The "final" elements of the input system, which are defined as the sequence logic and the pulse driver, respond to the input train of pulses as they are received on either the forward or the reverse line so as to energize the stepper motor windings with high power in the proper sequence to cause the motor to step in the chosen direction. Each low power input pulse causes one or more motor coil(s) to be energized with high power.

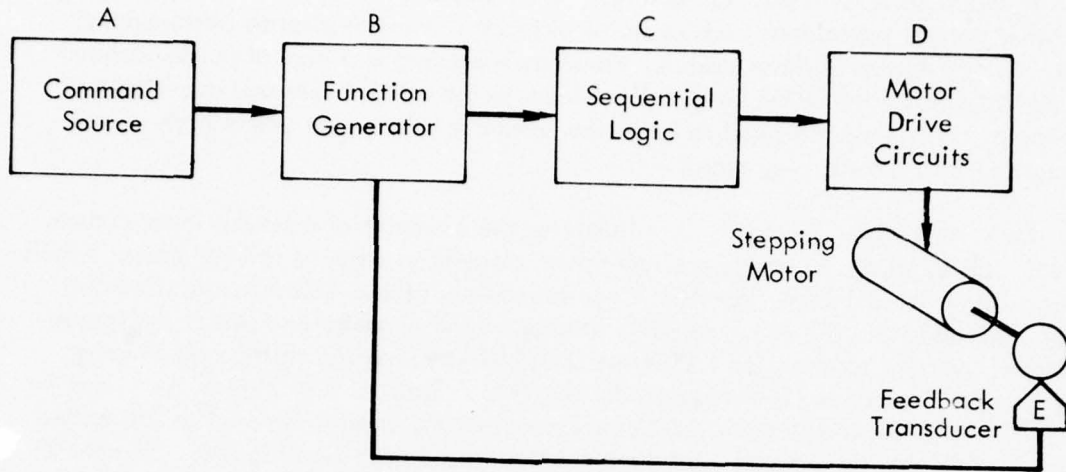

Figure 4 Simplified Stepping Motor Control System

The final elements provide low power circuitry to perform the sequencing -- the selection of which coils to energize -- and a solid state relay for each coil of the motor to switch in the high power.

Off-the-shelf hardware is available from most of the stepping motor suppliers to perform the function of the final elements. This hardware can be procured either in a chassis for rack mounting or on circuit cards. As in the case of the forward elements, the prototype packaging for the final elements will not be representative of an appropriate aircraft configuration.

The microcomputer concept is an important development in respect to future aircraft control systems using the EHPM. It is, therefore, appropriate to define the term and reflect on its relationship to the EHPM.

The basic arrangement of a digital computer is shown in Figure 5. It is noted that three basic elements are provided: A CPU, a ROM, and a RAM. The Central Processor Unit (CPU) controls the transfer of information and performs calculations, the Read Only Memory (ROM) is fixed memory and the Random Access Memory (RAM) is variable memory which will be altered continuously during system operation. These functions are the basic building blocks of a control system. Each can be thought of as separate circuits on a chip. They can be standard off-the-shelf hardware. A given microcomputer may consist of a number of these standard modules assembled into a black box. The number of ROM's and RAM's required depends upon the complexity of the control task. It should be noted that the ROM contains the fixed program that adapts the standard hardware to the special control task. For example, a black box to control the flap system may be exactly like a black box to control the forward cargo door complex. The only difference is the way the ROM modules are programmed. ROM can be reprogrammed by removing the module from the aircraft, erasing the existing program, and energizing a new program into the chip.

The term *microcomputer* was coined merely to connote size, both physically as well as functionally; i.e., size of memory and program capability. The concept is extremely important to the EHPM concept and to future aircraft controls because of low cost, small size, and high reliability. As one author aptly stated: "The day of the matchbox computer draws near". That is, small highly flexible digital controls will be used for the simpler control tasks.

Predictions of reduced cost and size, and higher reliability of computer modules have to a large degree already "come to pass" and the evidence sits on many engineer's desk -- the "electronic slide rule". The elements of these devices are the types of circuits that will provide the control functions for many EHPM input systems.

Electrical Pulse Motor (EPM) - A stepper motor is an electromagnetic incremental actuator which converts electrical pulse inputs to output motion. Two common acronyms are ESM (Electrical Stepper Motor) and EPM. EPM is used in this report.

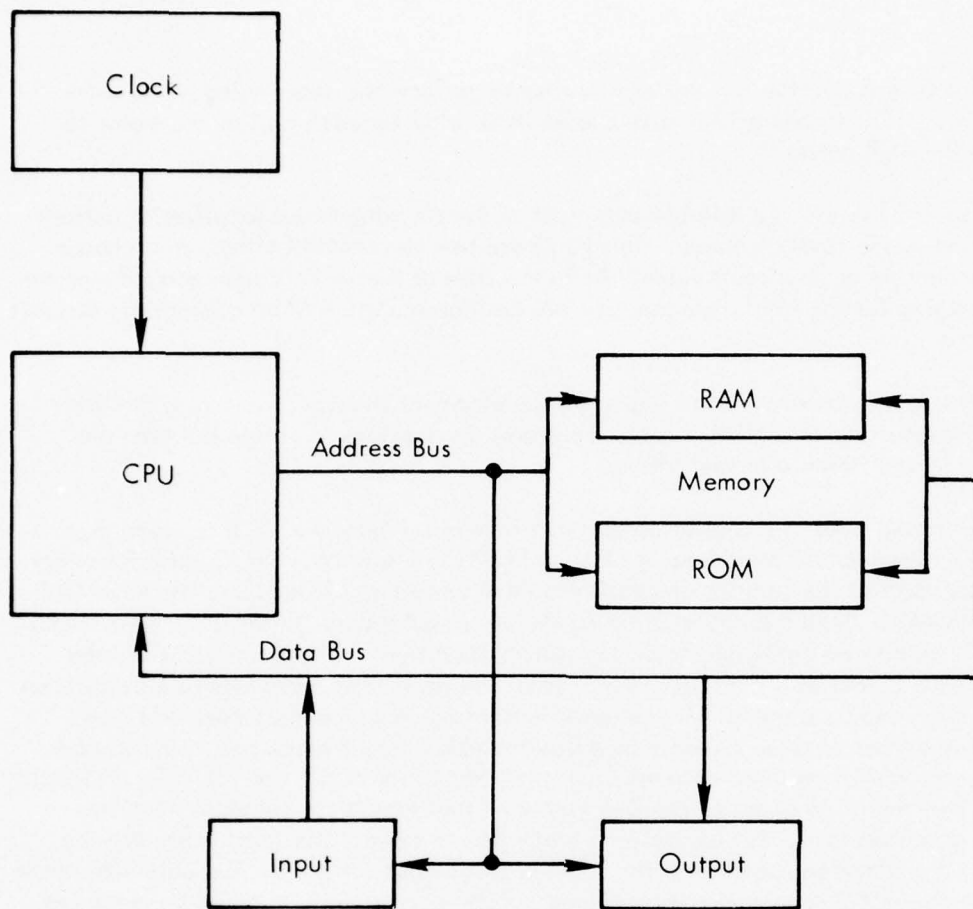

Figure 5 Organization of Microcomputer

When energized electrically in a programmed manner, it indexes incrementally. When operated within its capability the output steps are always equal in number to the number of input pulses. Each pulse advances the rotor shaft and latches it magnetically at the positions to which it is stepped. The motor provides rapid acceleration, stopping, and reversal.

An electronic circuit is required to transform the input pulse train into this sequential energizing pattern. The power level of the control pulse train is very low compared with the power level of the EPM coils so this circuit also involves amplification. This circuit is commonly referred to as the driver.

When operating in the slow mode, that is, running at a speed higher than its instantaneous start-stop or reversing speed range, the stepper motor will maintain synchronism with the pulse train. To start, stop, or reverse in this range of operation, the motor must be accelerated and decelerated to and from the slow speed. Thus, for acceleration, the frequency of the pulse train should be increased from the starting speed up to the final frequency, and for deceleration, the frequency of the pulse train must be decreased.

A list of stepper motor characteristics which are important to the design and application of an EHPM are as follows:

- o No accumulative error.
- o Predictable and consistent performance when within limits of capability.
- o Controls are digital; easily adapted to computer control; respond to pulse commands.
- o Simple; only two bearings in mechanical contact; no maintenance.
- o Usable open loop with desirable features of a feedback system; relatively clean null, no drift.
- o Quiet
- o Free from contaminants, not sensitive to contamination.
- o Can be repeatably stalled without damage.
- o Bidirectional rotation.
- o Fixed step angle or increment of motion.
- o Low efficiency.
- o Limited ability to handle large inertia loads.
- o Friction loads increase position error, error is non-accumulative.

Stepper motor technology involves its own unique terminology. Some of the more significant terms related to torque are discussed in this section and others are discussed in the Glossary of Terms, Appendix A.

Holding (Static) Torque - The holding torque curve is a fundamental torque characteristic of a stepper motor. The origin of the curve corresponds to a motor energized and at rest at any of its step positions. This curve shows the holding torque versus rotor angular displacement from the step position. This torque acts in a direction to force the rotor back to and hold it in the zero-torque step position.

The holding curve is one segment of the total torque-function curve corresponding to each phase of the motor. All other segments of these phase-torque-function curves are formed from this one holding torque curve, or its images formed by rotation about the vertical and horizontal axes. Thus, the holding torque curve is all that is necessary to completely determine the instantaneous torque of the motor under all possible static conditions of excitation and rotor position. All other torque characteristics, static or dynamic, have their origins in this holding torque curve.

Five segments of the holding torque curve for the HiPMO are illustrated in Figure 6. The displacement data are accurate for the HiPMO null positions, but the shape of the curve is arbitrary to illustrate the general appearance of a holding torque curve. Data to apply torque versus displacement numbers to this curve were not available in supplier literature nor was testing done to obtain it. If a system is to be modeled for computer analysis, the characteristic illustrated by this curve would need to be measured by tests wherein the motor is displaced a measured amount and the restoring torque measured for a set of displacements, encompassing $\pm 6^\circ$ for the HiPMO.

Pull-out Torque - The pull-out torque (torque-speed) curves, Figure 7, indicate the maximum steady-state friction torque which can be applied as a load on the motor at the corresponding speeds, or stepping rates, without pulling the rotor out of synchronism with the input pulse train and stalling the motor.

It is important to understand that the pull-out torque curves have no counterpart in the conventional motor field. They do not define operating points, nor are they representative of a transfer relationship. They simply define the region of torque-speed combinations inside which the motor will operate satisfactorily and outside which it will not operate at all, for a given set of excitation and control conditions.

A limitation to the significance of these torque-speed curves is that they assume constant velocity at a given speed. This is only true at stepping rates of several hundred steps per second, depending upon the motor, inertia load and control. A stepper motor is, in fact, starting and stopping at low step rates and changing instantaneously the step rate to a slightly higher step rate. Then, in this "stepping-mode" range, the motor must exert accelerating and decelerating torque on its own internal inertia and the coupled inertia in addition to the continuous torque implied by the speed-torque curves.

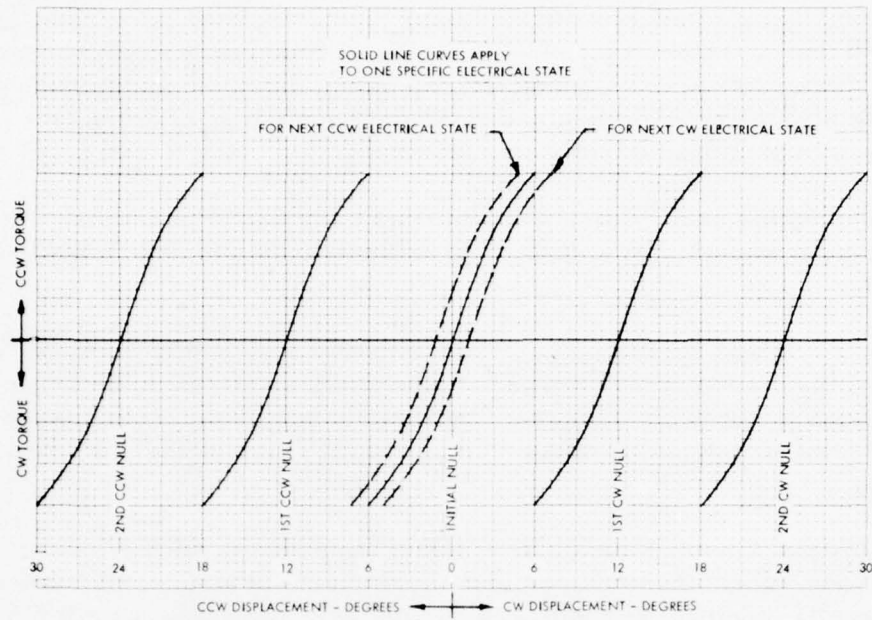

Figure 6 Family of Holding Torque Curves

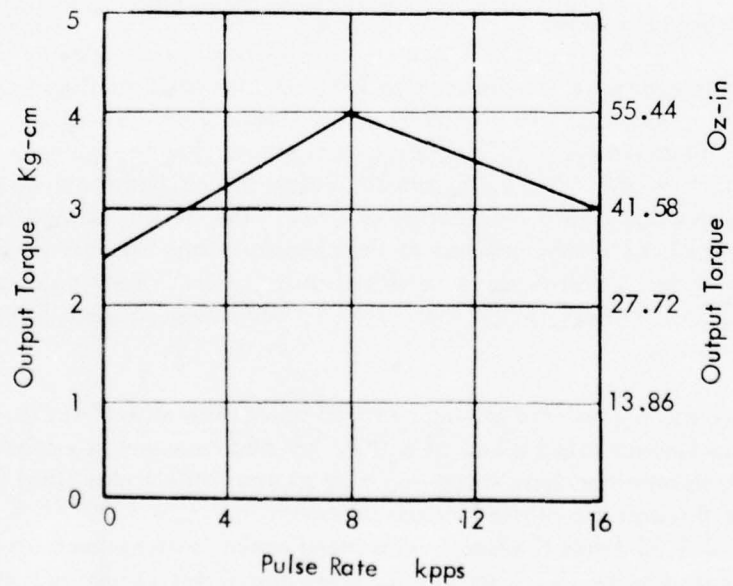

Figure 7 Pullout Torque Vs. Pulse Rate for Fujitsu Hi - PMO

In the open-loop mode, the motor must be operated below its maximum dynamic torque capability to ensure that the motor does not stall or miss steps. In the closed-loop (feedback or self-commutating) mode, the motor can be operated at, or near, its maximum dynamic torque. Motor heating under dynamic conditions is normally not a consideration. Motor ratings are determined by the power the motor can dissipate under static conditions with normal phases energized. When a motor is running, the current varies little with or without a load.

Stepper Motor Performance Presentation - In order to further illustrate performance characteristics of stepper motors, ICON's performance curves for the HiPMO are shown in Figure 8.

In Figure 8 (Sheet 1), the ordinate is the minimum acceleration/deceleration time constant and the abscissa is load inertia. The acceleration/deceleration time constant or time referred to means the value of T_a and T_d when pulse rate f of the input pulse train, as shown in Figure 8 (Sheet 2) rises and falls exponentially or linearly, respectively.

Hydraulic Motor - Aircraft hydraulic motors have been used to drive utility actuation systems for many years. With inherent characteristics of low weight, high power output and versatile operation for continuous, intermittent, reversible or stalled duty cycles, it enjoys a wide range of applications. Aircraft hydraulic motors are designed to specification MIL-M-7997B unless requirements are modified by a detail specification. The majority of developed motors are designed to operate in a 3,000 psi pressure system with oil temperatures from -65°F to 275°F . For military applications, MIL-H-5606 fluid is used. It is intended that the standard aircraft hydraulic motor with years of experience and development background will be used for the design of the integrated electro-hydraulic pulse motor (EHPM).

Standard aircraft hydraulic motors are available in two basic configurations: bent axis and in-line. The bent axis design has been the standard of the industry for many years. The newer in-line design is receiving wide acceptance due to its simple compact design and low cost and weight. In-line hydraulic motors are an outgrowth of proven pump design and are available in a wide range of sizes. The in-line design has been selected for development of the EHPM because of the simplicity and compactness of the complete assembly pulse motor, control valve, and hydraulic motor. Both major suppliers of hydraulic pumps and motors, ABEX and Vickers, have sizes ranging from .02 to 8 cubic inches per revolution.

Available sizes and normal and maximum rated speeds are shown in Figure 9. A theoretical, continuous rated speed of $6,000/\sqrt[3]{\text{displacement}}$ is added as a reference. This rating was determined from a log-log plot of available motor sizes and speeds by drawing a line through the plotted values as shown in Figure 10. A maximum intermittent speed of 1.25 times the continuous rated speed is also shown on this figure. It can be noted from Figure 10 that motor sizes above two cubic inch per revolution have higher continuous ratings and approach values of approximately $8,000/\sqrt[3]{\text{displacement}}$. This fact is indicative of the development of high speed, large displacement pumps and motors for late model aircraft.

Acceleration

Linear acceleration

Exponential acceleration

Refer to Sheet 2 for Definition of T_a and T_d

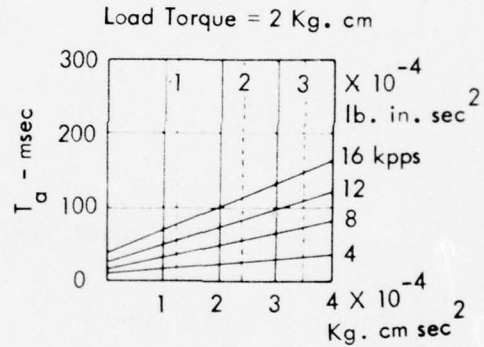
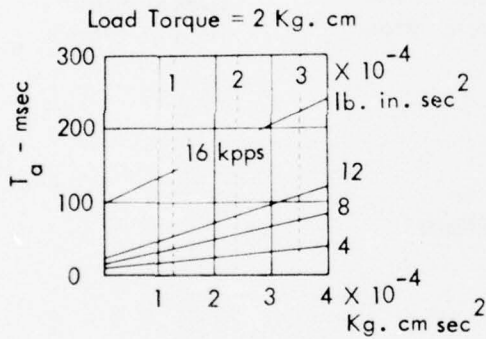
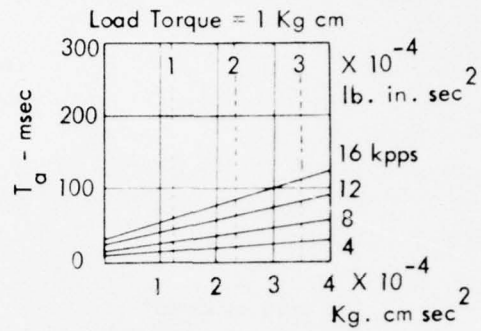
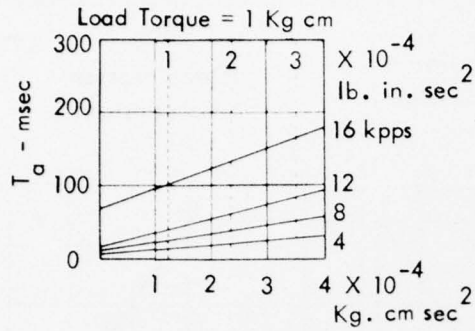

Deceleration

Linear deceleration

Exponential deceleration

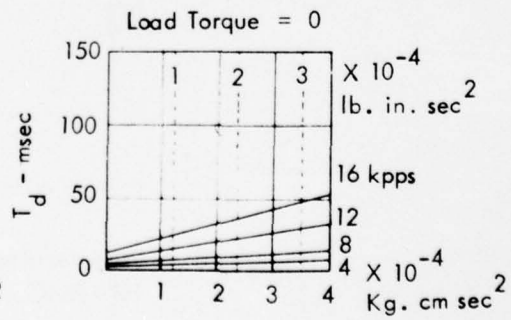
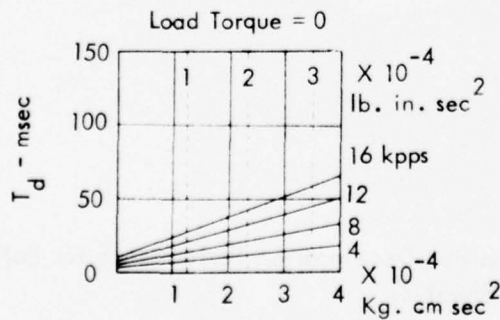
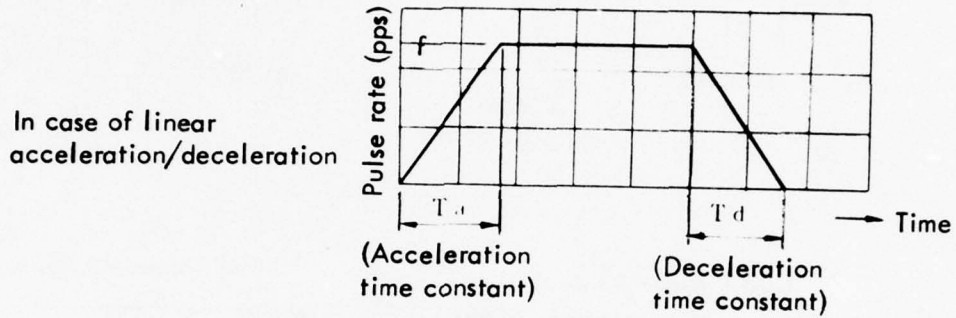
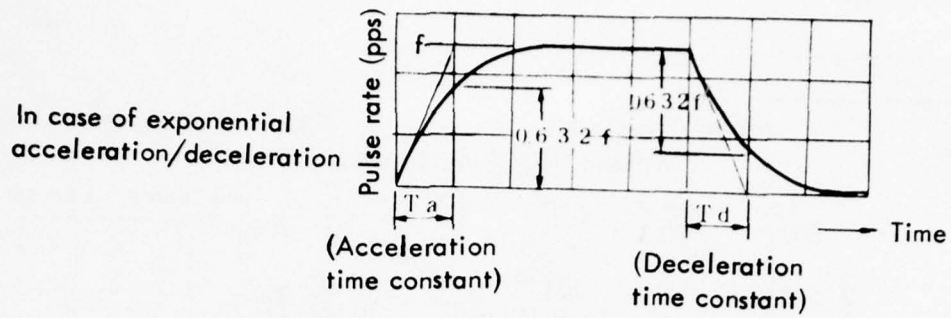

Figure 8 Acceleration and Deceleration Performance for Fujitsu Hi - PM 0 Sheet 1



Exponential Acceleration Equation:

$$R = f \left(1 - e^{-\frac{t}{T_a}} \right)$$

Exponential Deceleration Equation:

$$R = f e^{-\frac{t}{T_d}}$$

Figure 8 Acceleration and Deceleration Performance for Fujitsu Hi-PMO (Sheet 2)

<u>Displacement In³/Rev</u>		<u>Rated Speeds</u>		
<u>Abex</u>	<u>Vickers</u>	<u>Normal</u>	<u>Maximum</u>	<u>6000/$\sqrt[3]{DISP}$</u>
	.020	18000	22500	22104
	.030	18000	22500	19309
	.060	15000	18750	15326
0.10		10000	12000	12927
	0.11	12500	15600	12522
0.18		8500	11000	10627
	0.22	10000	12500	9939
0.31		8000	10000	8865
0.40		6500	7500	8143
	0.44	8000	10000	7889
0.67		6200	7200	6857
	0.75	7000	8750	6604
1.00		6000	7000	6000
	1.15	6000	7500	5727
1.37		5100	6000	5402
	1.50	6000	7500	5241
1.77		3750	4500	4960
2.00		5800	7200	4762
	2.05	5650	7100	4723
2.40	2.40	5300/4000	6600/4800	4481
3.00	3.00	5000/5400	6250/6600	4160
4.40		5000	6000	3662
6.5		4250	5300	3215
	7.14	3700	4600	3116
8.5		3750	4500	2940

Figure 9 Hydraulic Motors, Displacement and Speed

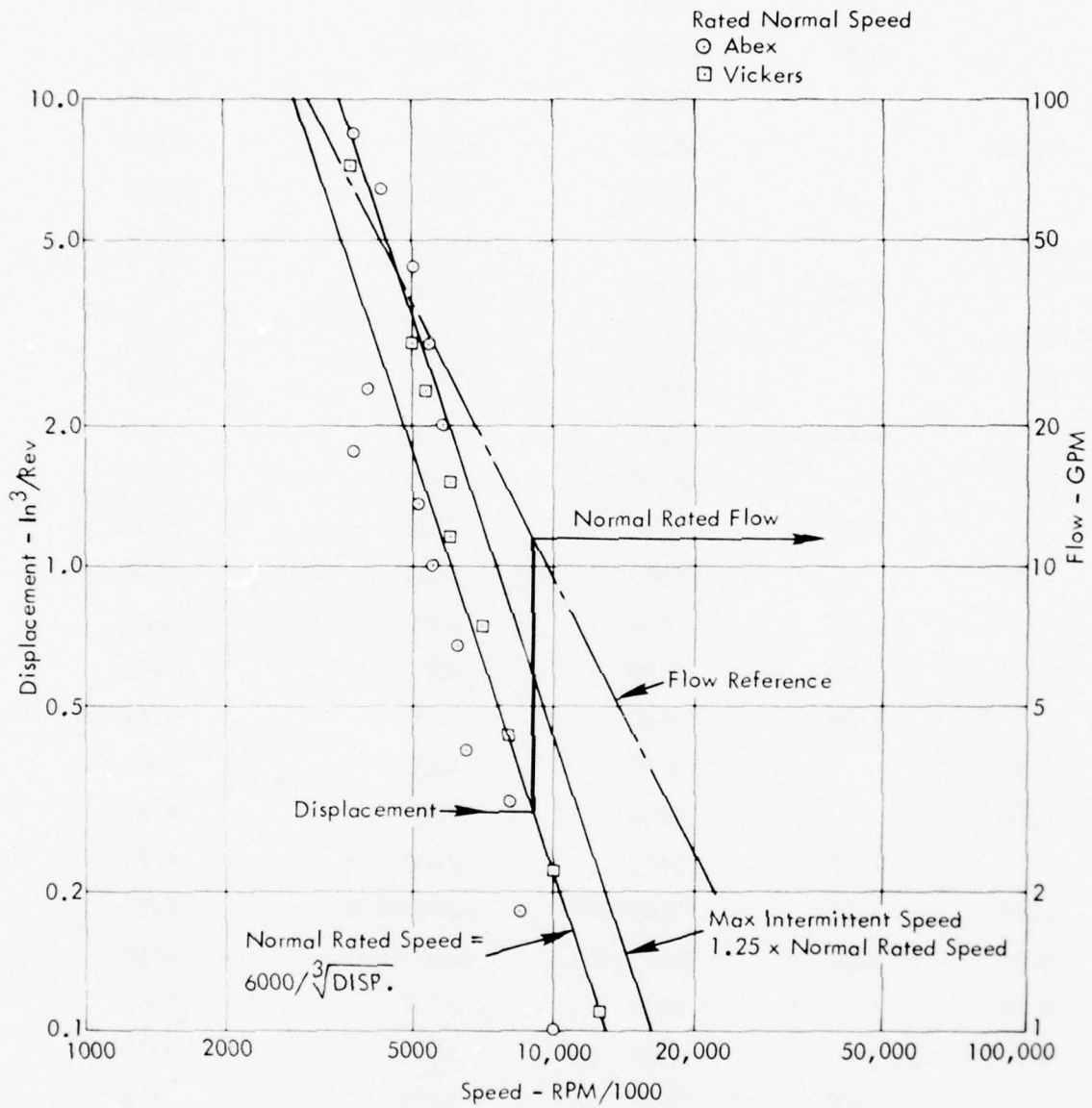

Figure 10 Hydraulic Motor Speed & Flow Characteristics

Standard mounting flanges on hydraulic motors interface with actuation system gearboxes. These standards are listed in the motor specification MIL-M-7997B. The following table lists the military standards with torque, weight, and overhung moment limitations. Detail dimension and requirements can be found on the respective standards.

<u>Motor Mount</u>	<u>Gearbox Mount</u>	<u>Torque</u> <u>in.-lb</u>	<u>Accessory Maximum</u>	
			<u>Weight</u> <u>lb</u>	<u>Moment</u> <u>in.-lb</u>
AND10260	AND20000	100	6	25
AND10261	AND20001	500	30	150
AND10262	AND20002	2,500	65	400

At 3,000 psi, the torque limitations permit motor sizes of maximum displacement of 0.2 in.³/rev on AND10260, 1 in.³/rev on AND10261, and 5 in.³/rev on AND10262.

In the EHPM, the control valve housing will replace the normal motor valve plate and port cap. The dimensions of the valve plate are peculiar to the particular motor design and are critical to proper pressure balances. Therefore, these dimensions will not be detailed in this report. The dimensions should be identical to the present motor port cap in the area of the motor valve plate. The valve plate must be a hardened steel material and the valve housing aluminum (for minimum weight). Typical valving surfaces of hydraulic motors are illustrated in Figure 11. Designs utilizing a thin intermediate valve plate and aluminum port caps are common where port caps are more complex and weight is critical. Attachment of the valve housing to the motor housing can be made by the same bolt arrangement used for attachment of the port cap.

Performance characteristics of hydraulic motors are well known and defined by relatively simple equations. The most important characteristics relative to EHPM units are related to flow and torque, both being proportional to motor displacement. Flow is also proportional to speed, and torque is proportional to pressure across the motor. Although flow is essentially constant at any given speed, the torque is determined by load and pressure across the motor and is controlled by valves. The maximum motor torque is essentially constant throughout its rated speed range at constant pressure. However, at higher speed, lower pressures are available at the motor due to line and valve pressure drops. This discussion is based on theoretical values that should be adjusted by efficiency. Hydraulic motor efficiency is high when operating at rated pressure and speed. Efficiency is only critical when operating at peak loads. In this area, the overall efficiency is above 85% and the torque efficiency is above 90%. At other than peak loads, the control valve easily adjusts to maintain the desired speed and load torque.

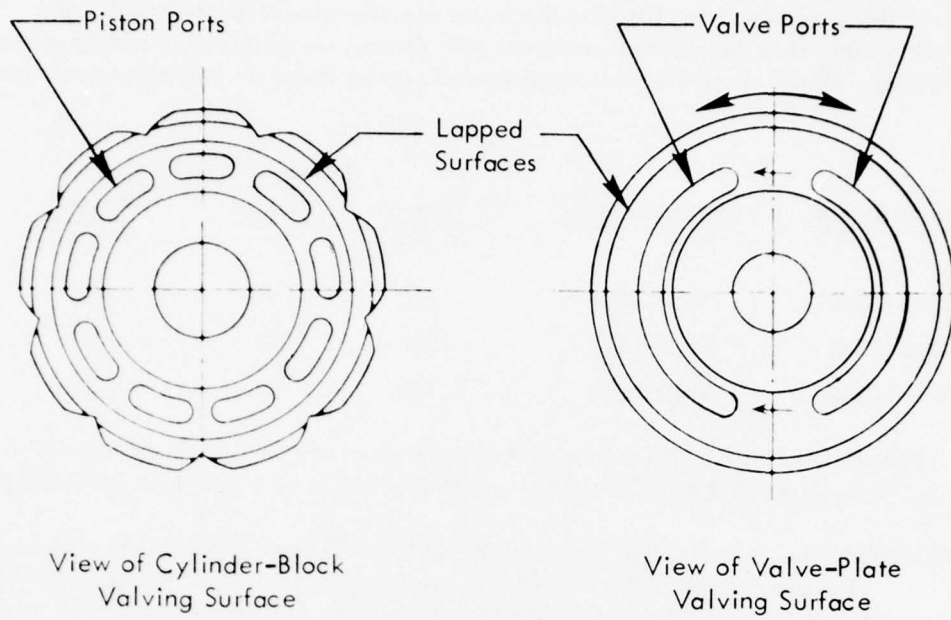

Figure 11 Typical Valving Surfaces Hydraulic Motor

The performance of standard in-line hydraulic motors has discontinuities which are caused by rapid changes in internal leakage at break-out and substantial drop in output torque at low speeds. The in-line motors utilize the metered hydraulic flow to supply both the hydro-static shoe balance flow and the piston displacement (output motion) flow. When operating with normal loads and moderate speeds, they operate smoothly and efficiently. When there is no required output motion or where output velocity commanded is low, operation can be erratic. This is due to the variable flow going to normal leakage, to shoe balance, and to the piston displacement which gives the output motion. For those load conditions where the output torque is higher statically than it is for relatively low speed, jerky operation can be expected until the commanded speed exceeds the low speed range. To avoid this undesirable operation, minimum operating speed must be maintained above 10% of normal operating speeds. This minimum operating speed is compatible with the majority of utility actuation system requirements.

Analysis has shown that unless the driven load is predominantly inertial (such as radar antenna positioning) and low speed operation is required, standard in-line hydraulic motors may be used for utility actuation systems. Most utility applications have both inertia and torque load requirements due to weight and aerodynamic loads. In addition, general operating requirements of utility actuation systems involve movement from one position to another in a specified time and do not involve small corrections.

Modified in-line hydraulic motors have been built for servo application of pure inertial loads. One such unit is an ABEX hydraulic servomotor designed to supply the piston leakage and shoe balance flow directly from the hydraulic pressure source rather than with control valve metered flow, thus essentially forcing all control flow to provide output motion. The result is that smooth operation can be maintained to considerably lower speeds. With such a motor, the amount of valve motion required to realize a given static torque is reduced compared to the case where the valve must also supply leakage and shoe balance flows. The output stiffness is, therefore, increased.

Control Valve - The design of modulating control valves is a rather extensive subject covering many types and many construction techniques. To review the various types of valves is not the intent of this study. The most commonly used modulating control valve configuration is the spool and sleeve and it has been selected for the EHPM unit. This type of valve was selected because of the simplicity of its characteristic equations and the general knowledge of construction techniques. In the aviation industry, these valves are used for controlling flow and pressure to flight control actuators, in electrohydraulic valves, and in utility system direction control valves.

The specific spool valve selected for study is a balanced, four-land valve with zero lap as shown in Figure 12. In normal usage, the valve is translated by mechanical or hydraulic means to obtain the modulation of hydraulic pressure and flow. In the EHPM unit, the pulse motor rotates the spool (or the nut) causing translation through the feedback thread or translator attached to the hydraulic motor. The

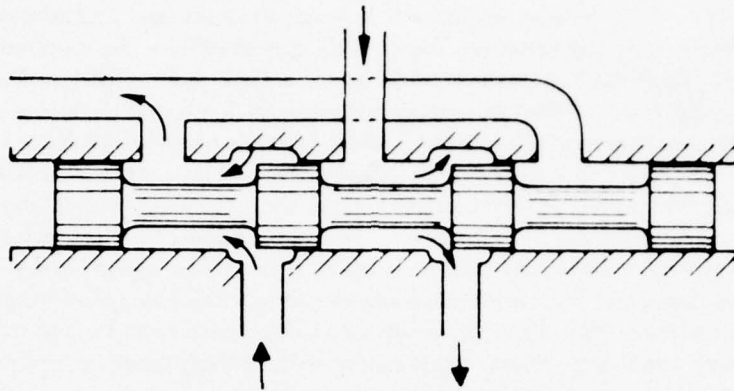

Four-Land Valve, Balanced

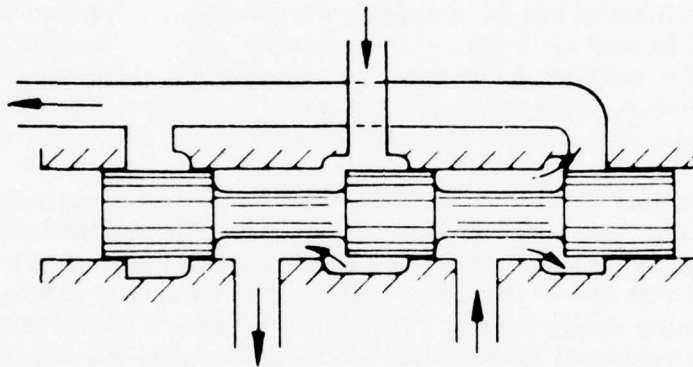

Three-Land Valve, Balanced

Figure 12 Balanced Spool Valve Configurations

following discussion will determine the details of the physical and performance interfaces necessary to integrate the control valve into the EHPM.

Valve Sizing and Flows - In the previous discussion of hydraulic motors, a wide range of available sizes and operating speeds were shown. The motor size (displacement) and operating speeds determine the flow required for motor actuators. The equation for determining motor flow requirements is:

Flow = Displacement x speed/231. When flow is in gallons/min, displacement is in in.³/revolution and speed is in rev/min. The wide range of motor displacement and operating speeds require valve sizes ranging from 1 to 100 gpm as shown in Figure 13.

It is not practical to design a valve for each motor size due to the large variety of motor sizes. A group of standard valves may be designed to match motor sizes and operating speeds.

Valves are sized by flow requirements and pressure drops for minimum physical size and weight. Past efforts to standardize valve sizes have been related to plumbing line sizes and size designation does not always indicate the flow capacity of the valve.

Raymond Atchley, a Division of ABEX, has established electrohydraulic servo valve sizes of 1, 5, 10, 25, and 50 gpm with rated flow pressure drop equivalent to one third of the source pressure. It is interesting to determine the basic dimensions of a series of valves based upon flows and fluid velocities that control the pressure drop. This relationship is stated in the equation:

$$Q = \frac{VA}{.3208} \quad \text{Where } Q = \text{flow, gals/min}$$

$$V = \text{fluid velocity, ft/sec}$$

$$A = \text{flow area, in}^2$$

Changing A to $\frac{\pi}{4} D^2$ and solving for D (The valve spool diameter)

$$D = \sqrt{\frac{Q}{2.448V}}$$

Assuming a constant velocity of 26.14 ft/sec, a reasonable velocity to minimize pressure drop, the denominator becomes $\sqrt{64}$ or 8; therefore:

$$D = \frac{\sqrt{Q}}{8} \quad \text{at } V = 26.14 \text{ ft/sec}$$

Assuming a series of valve sizes where the spool diameter varies in one eighth inch increments - Q or flow sizes are 1, 4, 9, 16, 25, 36, 49, etc. closely paralleling the Raymond Atchley sizes and providing a series of valves with constant flow velocities. The potential standard size valves are shown on Figure 13. for matching valves and motors.

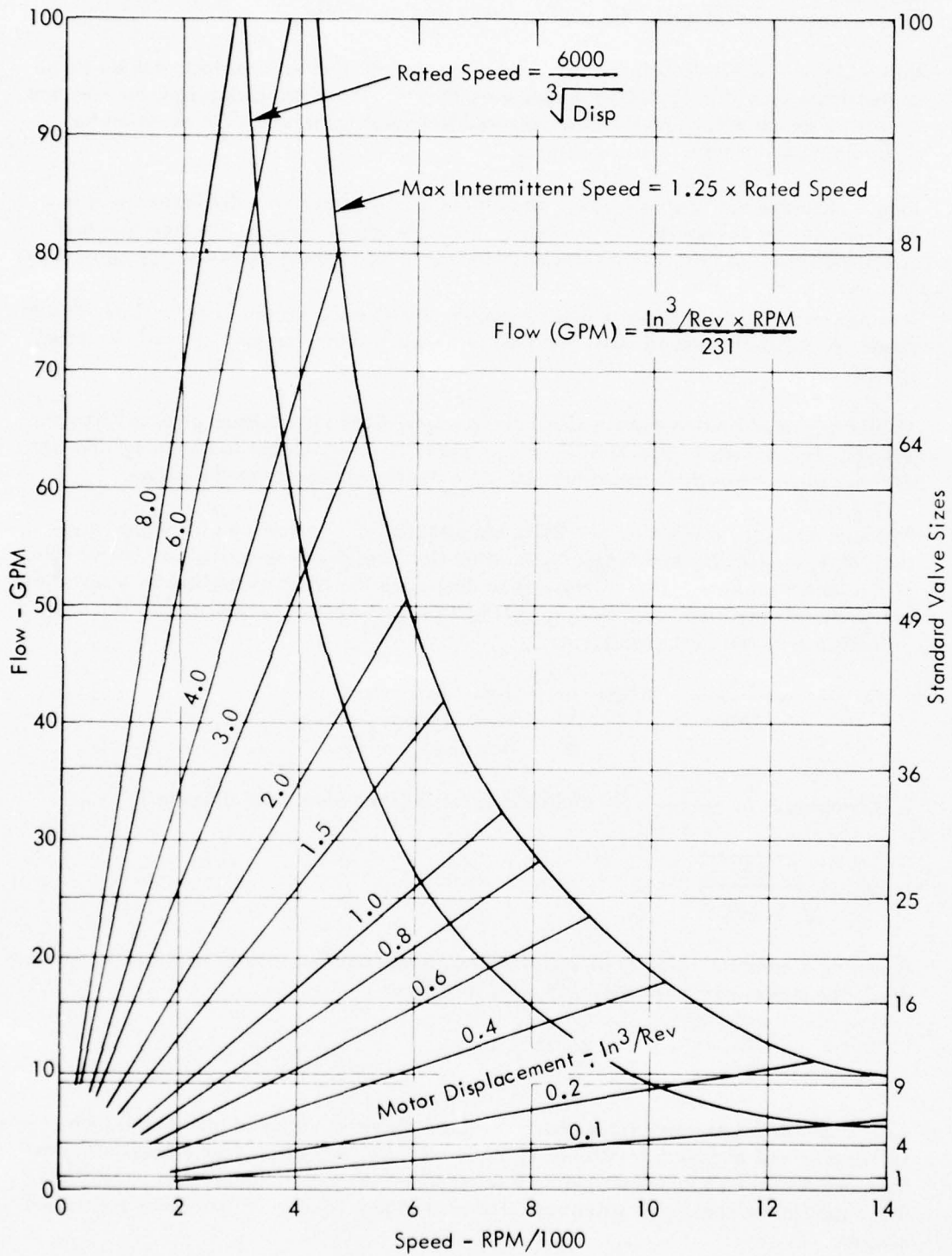

Figure 13 Motor/Valve Matching

Other basic dimensions of the valves can now be determined. The flow areas of the pressure and return ports through the spool should also be of low velocity and are $A = .3208 Q/V = .01 \text{ (in.}^2\text{)}$ at a velocity of 32.08 ft/sec^2 . The stem of the piston should be half of the piston diameter and the outside of the sleeve two times the piston diameter to provide sufficient stiffness and rigidity so as to prevent distortion from pressure and valve housing loads. The land width is also approximately half of the land diameter and the maximum stroke is half the land width to provide sufficiently low valve gain, as discussed later under the stability analysis. One final item prior to tabulating the valve dimensions is the thread of the valve translator or spline which is logically placed on the valve stem, and therefore, is basically half the spool diameter. These dimensions facilitate the use of standard tools and seals. The maximum diameter of the sleeve for all sizes of valves and motors allows axial mounting of the valve within the normal flow paths of the motor port plate.

The standard valve sizes and dimensions of Figure 14. provide minimum pressure drop at rated flows for all areas except the control ports. The two center lands of the four land valve control the flow to and from the hydraulic motor. The design of the ports determine the valve gain and are generally of rectangular shape for constancy of valve gain. Both the inlet and outlet ports are identical and are treated as two orifices in series with the load. Maximum gain occurs at zero load torque and in a 3,000 psi system each orifice has a pressure drop of 1,500 psi. As load is applied, the valve translates to increase the orifice size and provide the required load flow and pressure. It can be shown by calculation that the maximum power a valve can deliver occurs when the valve pressure drop is one third of source pressure. This method of sizing the valve and control orifices is helpful in standardizing valve designs and is often stated as 1,000 psi pressure drop at rated flow for a 3,000 psi source pressure. Caution must be used when source pressures are reduced by line losses at high flow rates or low temperature operation. Under these conditions, the required load pressures may not be available and the valve control orifices may need to be increased in size to decrease drop at high flow rates.

Valve Drive Loads - The predominant forces required to control a spool valve are commonly called flow forces and are directly proportional to the rate of flow through the valve. Valve flow is controlled by the valve lands moving across the metering orifices. The axial force on the spool is equal to the axial component of the net change of momentum. The following equations are derived in Section 10.3 of Reference 3:

$$F = QVp \cos \theta$$

Where:

$$Q = \text{flow - in}^3/\text{sec}$$

$$V = \text{velocity - in./sec}$$

$$p = \text{mass density - lb-sec}^2/\text{in}^4$$

$$F = \text{force - lbs}$$

The angle θ is the jet angle of the flow stream leaving the control orifice and is a function of the valve displacement divided by the radial clearance. With a valve clearance of .0001 inch and valve displacement of .006 inch or more, θ approaches 69° . The maximum force occurs at no load when there is a maximum pressure drop across the orifice. In a 3,000 psi system, the maximum pressure drop for each orifice is 1,500 psi. The equation supplies the axial flow force for a single orifice and the force always tends to close the valve.

Flow GPM	Dia. Spool Inches	Dia. Stem Inches	Dia. Sleeve Inches	Width Land Inches	Stroke Inches
1	.125	.062	.250	.062	.031
4	.250	.125	.500	.125	.063
9	.375	.1875	.750	.1875	.0934
16	.500	.250	1.000	.250	.125
25	.625	.3125	1.250	.3125	.156
36	.750	.375	1.500	.375	.188
49	.875	.4375	1.750	.4375	.219
64	1.000	.500	2.000	.500	.250
81	1.125	.5625	2.250	.5625	.281
100	1.250	.625	2.500	.625	.313

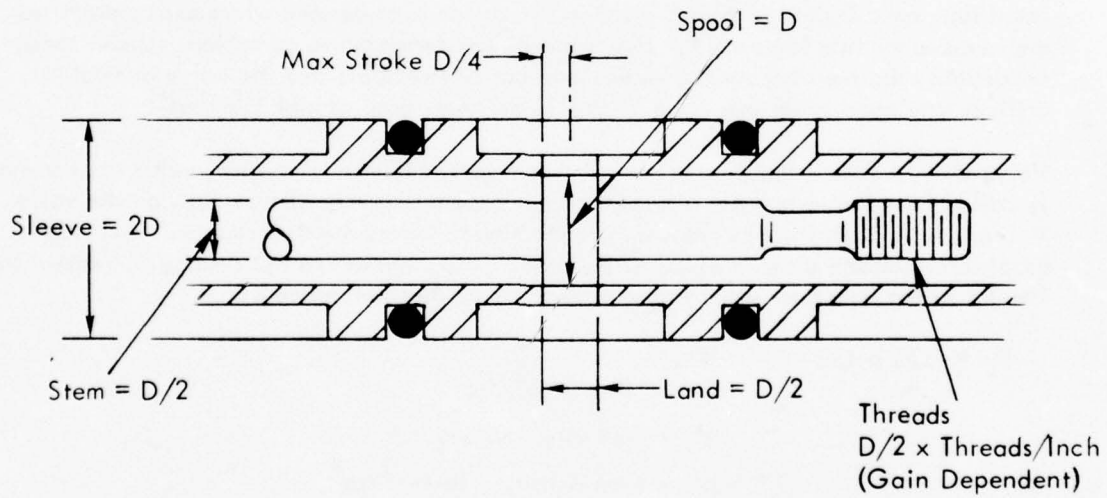

Figure 14 Valve Basic Dimensions

In an actual four-way valve, there are two identical orifices in series, therefore, there is twice the force on the piston. Total force on the piston is:

$$F_T = 2F = 2QV p \cos \theta$$

Substituting $V = \sqrt{(2 \Delta P)/\rho}$, $\theta = 69^\circ$ and a specific gravity of .85 for MIL-F-5606 fluid provides a further simplification.

$$F_T = 0.0064 Q \sqrt{P_V}$$

where $Q = \text{in}^3/\text{sec}$, P_V is in psi and is the total valve pressure drop for two identical orifices in series or:

$$F_T = 0.0246 Q_1 \sqrt{P_V}$$

where $Q_1 = \text{gallons/minute}$

The total axial forces for valves from 0 - 100 gpm capacity is shown in Figure 15. The maximum force is at no load for a valve P_V of 3,000 psi. Other lines indicate a reduction of flow forces at lower valve pressure drops due to reduced source pressure at the valve or increased load pressure.

The above analysis is made for steady state flow conditions. Under dynamic conditions when the valve and flow must be accelerated, other forces act on the valve. Analysis of the dynamic loads of a typical 25 gpm valve indicate that the loads, with response requirements for utility actuation systems, is less than one percent of the steady state flow forces. The dynamic loads do not occur at peak steady state flow. Therefore, at any other flow sufficient forces are available to accelerate the spool. It is considered appropriate to design for steady state flow forces and ignore the dynamic forces.

Translator Design - In the proposed EHPM, the valve axial forces are converted to torque through a nut and screw arrangement called a valve translator. The screw is attached to the valve stem and the nut is driven by the pulse motor. Three thread standards were evaluated for the translator design: the general purpose 29° acme; the American standard coarse thread series; and the American standard fine thread series. All of these have standard major diameters to match the valve stem diameters except in the two smallest size valves.

The torque to drive the spool can be determined from the following equation taken from Chapter 5 of Reference 4:

$$T = r_t F \frac{\cos \theta \tan \alpha + \mu}{\cos \theta - \mu \tan \alpha}$$

where: T = torque - in/lbs
 r_t = thread radius at pitch line - inches
 θ = one half thread angle - degrees
 α = helix angle computed at the pitch line
 μ = coefficient of friction

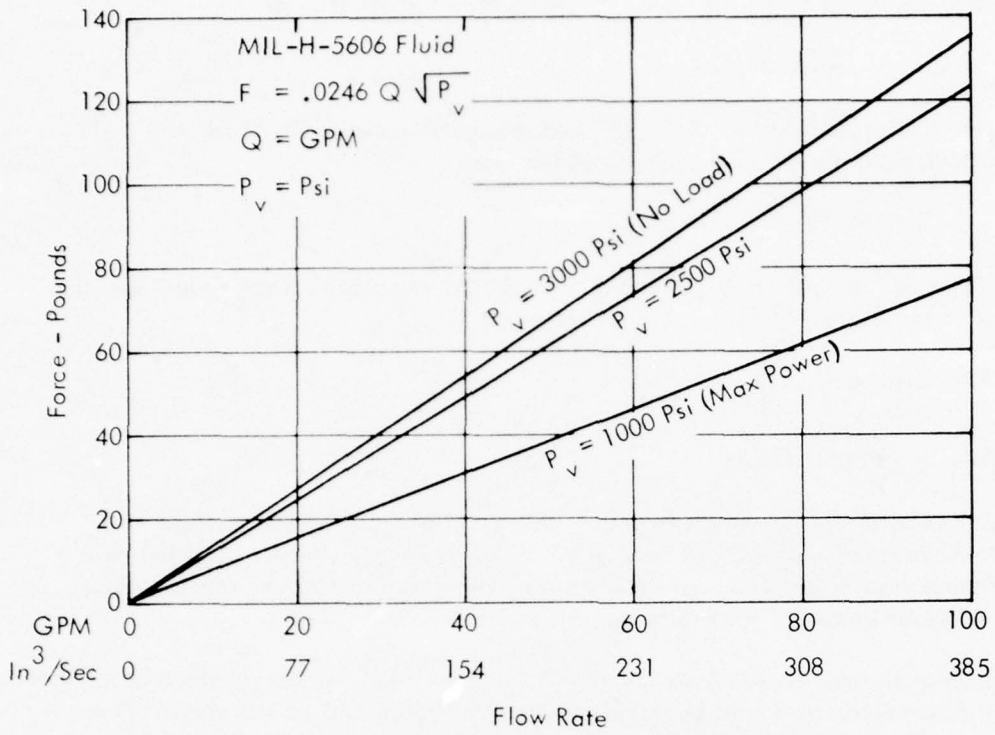

Figure 15. Valve Flow Forces

This equation assumes the use of anti-friction bearings to support the collar loads as in the proposed design.

Figure 16 lists the various valve sizes and data to determine the valve driving torques for both the acme and course thread series. The coefficient of friction is assumed to be 0.05 for a well-lubricated hardened surface. The values of torque versus flow are shown for valve sizes from 0 to 100 gpm in Figure 17. The torque is plotted as a continuous curve to indicate the approximate maximum torque for various size valves at rated flows and maximum pressure drop at no load. For any particular valve, the torque is directly proportional to the flow and the flow forces. In the two thread series analyzed, the torque values are close on all sizes and vary slightly due to thread pitch. The fine thread series was briefly evaluated but considered to be too fine a thread for a power screw application. Non-standard threads were also considered and may be used to provide specific valve gain characteristics, however, in the prototype design standard thread series are used because of available standard tooling.

The translator may be placed at either end of the valve spool. In the Fujitsu unit, the translator is placed at the hydraulic motor end of the spool and the torque required to rotate the spool must be supplied by the pulse motor because the pulse motor drives the spool. At the lower speeds and controlled temperature environment of the machine tool applications, the rotational torque requirements are acceptable. With the higher motor speeds and cold temperature requirements for aircraft applications, the rotational torque loads increase. Because of this increased load, the translator was moved to the pulse motor end of the spool and the hydraulic motor drives the spool through a spline that allows spool translation.

The torque required to rotate the spool is caused by viscous drag forces between the rotating spool lands and the stationary valve sleeve. Newton's equation for determining the relationship between shearing stress in the oil film and the force required can be adapted to the journal bearing. If the speed and viscosity are high and the load is very light, so that the journal is in a central position in the bearing, the following equation, known as Petroff's equation, can be used:

$$F = \frac{\mu v A}{c}$$

Where F is the tangential force, μ is absolute or dynamic viscosity, v is surface velocity, A is journal area, and c is the radial clearance.

Changing the terms and units to a more usable form, the equation becomes:

$$F = \frac{\mu \pi^2 d^2 L N}{c (60 \times 144)}$$

Where d (land diameter), L (total land length), and c are in inches, N (spool speed) in rev/min and μ is absolute viscosity.

GENERAL PURPOSE 29° ACME
 $\theta = 14-1/2^\circ$

<u>Valve Flow Size-GPM</u>	<u>Thread Size</u>	<u>Pitch Diameter Inches</u>	<u>α Degrees</u>	<u>Force Pounds</u>	<u>Torque in. Ounces</u>
16	1/4 x 16	.2187	5.2	21.56	5.39
25	5/16 x 14	.2768	4.7	33.68	10.10
36	3/8 x 12	.3333	4.55	48.51	16.97
49	7/16 x 12	.3960	3.83	66.02	25.09
64	1/2 x 10	.4500	4.05	86.23	37.94
81	9/16 x 10	.5125	3.55	109.13	50.96
100	5/8 x 8	.5625	4.05	134.74	74.11

AMERICAN STANDARD COURSE THREAD
 $\theta = 30^\circ$

<u>Valve Flow Size-GPM</u>	<u>Thread Size</u>	<u>Pitch Diameter Inches</u>	<u>α Degrees</u>	<u>Force Pounds</u>	<u>Torque in. Ounces</u>
4	10 x 24	.1629	4.65	5.39	0.97
9	12 x 24	.1889	4.02	12.13	2.30
16	1/4 x 20	.2175	4.19	21.56	4.96
25	5/16 x 18	.2764	3.66	33.68	9.09
36	3/8 x 16	.3344	3.41	48.51	15.52
49	7/16 x 14	.3911	3.33	66.02	23.77
64	1/2 x 13	.4500	3.11	86.23	34.49
81	9/16 x 12	.5084	2.99	109.13	49.11
100	5/8 x 11	.5660	2.93	134.74	66.02

Figure 16 Valve Torque Calculations

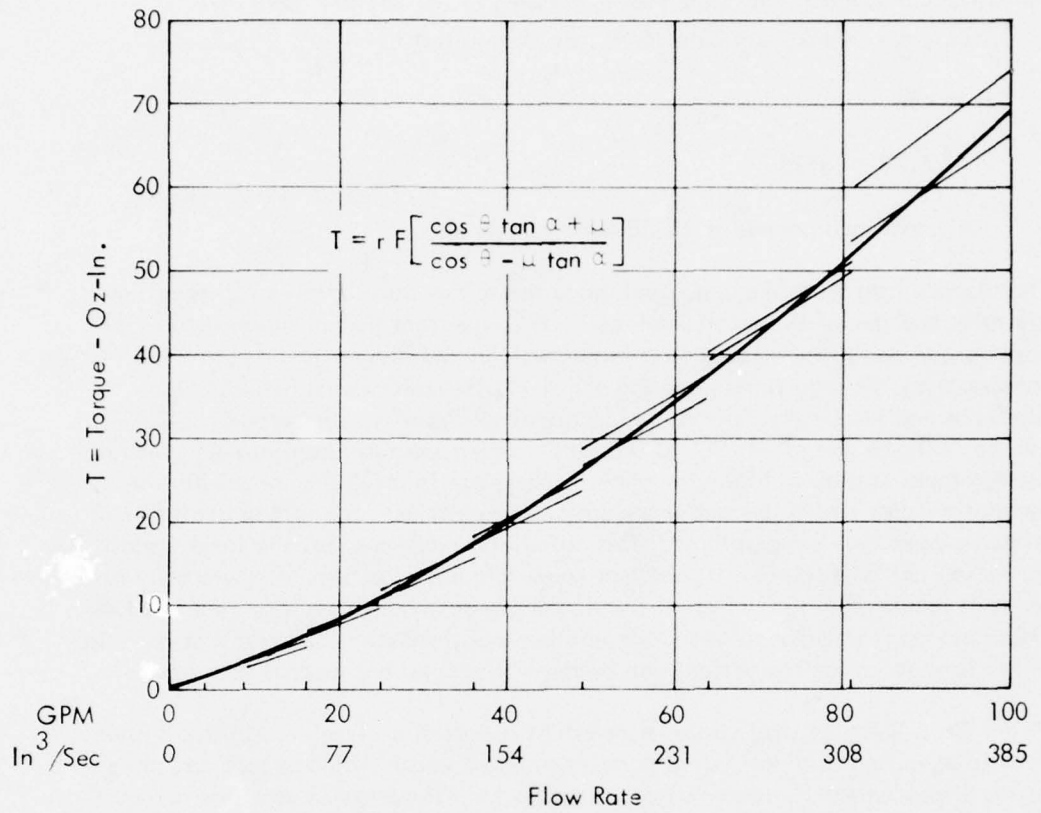

Figure 17 Valve Torque

For a typical 25 gpm, four land valve, running at 4,000 rpm ($d = .625$, $L = .3125$, $c = .0002$, $\mu = 20 \times 10^{-5}$), the tangential force is 2.23 pounds.

$$\begin{aligned} T &= Fr \\ &= 2.23 \times .3125 \\ &= .696 \text{ inch pounds or } 11.15 \text{ inch ounces} \end{aligned}$$

The viscous drag torques are equivalent to the torque due to valve forces at the viscosity and rpm of the valve analyzed. It is apparent that at higher fluid viscosities and rpm's, the viscous drag torque will increase significantly. At low temperature, the drag torque can exceed the pulse motor capabilities. Since the force and torque are directly proportional to viscosity, the torque at -20°F can be 13 times and at -40°F , 30 times normal temperature drag torque. Because these torques can be so high, the change was made to drive the spool with the hydraulic motor where the torque required represents only 5% torque available at minimum operating temperatures. This calculation assumes that the fluid viscosity at the journal bearing stays at ambient temperature viscosities. The viscosity may be reduced locally due to friction of the rotating spool, but this action requires time. Other design features such as increased clearance, reduced land width or grooving of the land (a common practice) can be done to reduce the viscous drag forces.

Valve Gain - The control valve in an EHPM is part of a closed loop servo system. Prior to selection of detail valve parameters (flow versus displacement and pressure versus displacement characteristics), a closed loop servo system analysis is required. This analysis determines the highest closed loop gain that can safely be used in the system and satisfy the stability criterion.

The closed loop servo system within the EHPM includes the following components: the hydraulic motor; the control valve; and the feedback translator device. Stability criterion for this type of system have not been published, but good design practice dictates a gain margin of at least 6 db; i.e., the loop gain could be increased by a factor of two before encountering system instability. This criterion is consistent with MIL-F-9490D which specifies gain and phase margins as a function of airspeed and aeroelastic mode frequency. In general, worst case stability for an EHPM system would occur at zero airspeed. For this condition, MIL-F-9490D specifies a gain margin of 6 db with no phase requirement below minimum operational airspeed.

Derivation of the expression for the closed loop gain of an EHPM operating at zero airspeed (no load) is presented in the design section for the prototype EHPM. The following equation may be used for any system after the loop gain and stability criterion has been developed:

$$\text{Loop Gain} \left(\frac{1}{\text{Sec}} \right) = \frac{K_v K_t}{D}$$

Where: K_v is the control valve flow gain at null ($\text{in}^3/\text{sec-in}$), K_t is the translator feedback gain (in/rev), and D is the hydraulic motor displacement (in^3/rev).

A simplification of this equation can be made if the flow to be determined at one revolution of the spool is desired. The number of threads per inch drops out and the loop gain is expressed in terms of flow and motor displacement as follows:

$$\text{Loop Gain} \left(\frac{1}{\text{Sec}} \right) = \frac{Q (\text{in}^3/\text{sec})}{D (\text{in}^3/\text{rev})}$$

It is emphasized that the loop gain must be determined at no load flow which is the maximum valve gain and worst case stability. Assuming that the valve has one third of the source pressure drop at full load, the no load flow is the ratio of $\sqrt{P_s/PI}$ or $1.732 Q$ where Q is the valve flow at maximum EHPM operating speed.

Open Versus Closed Loop Trade Study

Traditional technology to interface low level electrical command signals with a drive system is to use an electrohydraulic servo valve in a closed loop system. Feedback signal to the servo valve is usually taken from a position sensor on the load. Special cases exist where a mechanical feedback is used in lieu of electrical feedback and others where a velocity transducer feedback signal is used in combination with the position sensor feedback. These are used in a small percentage of applications. A block diagram of a closed loop electrohydraulic servo system is shown in Figure 18.

This technology, however, has not been employed to drive aircraft utility systems. The primary reason is the lower total cost of a simple mechanical input system and the inherent reliability of mechanical controls. With the advent of low cost, high reliability digital control technology, however, the use of servo systems to control aircraft utility functions seems to be feasible. The advantages of such an arrangement include the capability to reduce overall system weight, reduce cost, introduce modifying controls not feasible with the mechanical input systems, and reduce the exposure of the hydraulic system to fatigue from pressure surges.

A digital closed loop system of the type shown in Figure 18 was evaluated against an open loop EHPM system shown in Figure 19. The results of this qualitative evaluation were put in matrix format in Figure 20.

It is concluded that the EHPM is well suited for aircraft utility functions. The response requirements (bandpass) of utility systems are much lower than flight control systems where Electro Hydraulic Valve (EHV) servos are extensively used. It is concluded that the bandpass of the EHPM is not a penalty for utility systems.

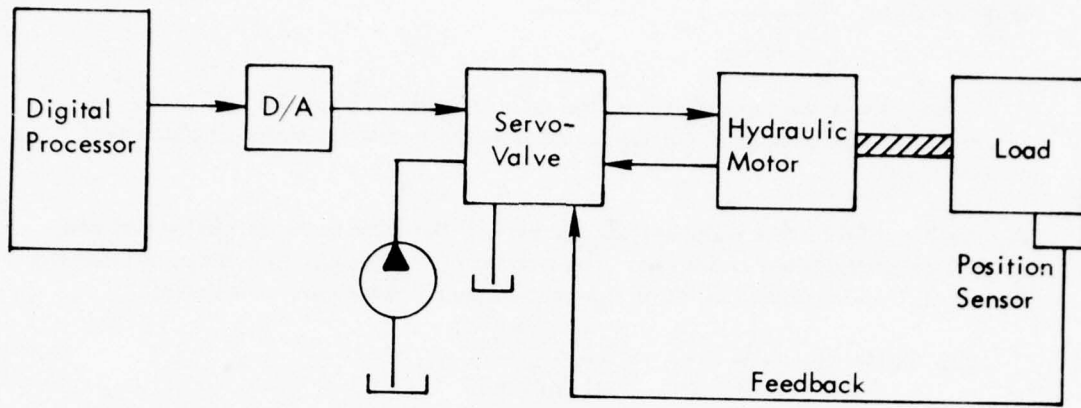

Figure 18 Closed - Loop EH Servo System

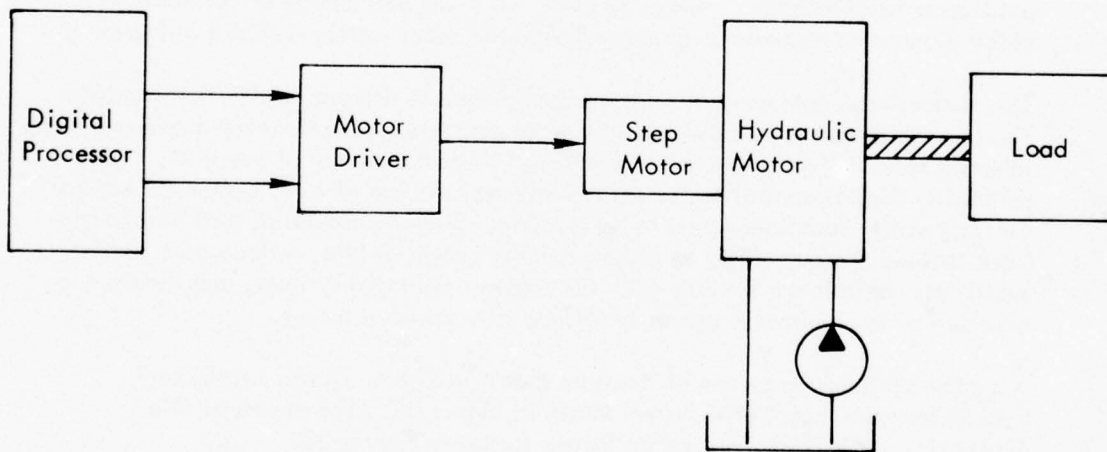

Figure 19 Open - Loop EHPM System

<u>Characteristics</u>	<u>EHV Servo</u>	<u>EHPM</u>
Nature of Device	Displacement Input, Position Output	Pulse Train Input, Position Output
Inputs	Analog Voltage - Other Inputs through D/A Converter	Uniform Pulse Train or Random Positive or Negative Pulses
Outputs	Depends upon Position Feedback Gain	Exactly Determined by Number of Input Pulses
Feedback	Position of Output Member; Sometimes Velocity	Not required
Loop Gain-Linearity	Set High for High Linearity	Stepping Linearity does not require Feedback
Stability	Simple Analysis Usually Sufficient	Same
Error	Depends upon Feedback Transducer Resolution, Linearity, Quadrature Noise, etc.	Depends upon Accuracy of Individual Stepping Mechanism Within Limits of Designed Stepping Rate
Bandpass	Zero to High Frequency Response Device	Relatively Low Frequency Response Device
Digital Programming	May be Adapted with D/A Input Device and Data Encoder on Output Shaft	May be Commanded Directly by Computer or Tape Pulse Train
Quiescent Power (Typical Application)	.2 Watts Electrical; 455 Watts (.34 gpm) Hydraulic	12 Watts Electrical; 320 Watts (.24 gpm) Hydraulic
Life-Reliability	Dependent upon Amplifiers, Feedback Transducer, Hydraulic System Cleanliness, D/A Converter	Dependent upon Shaft Bearing, Thermal Environment Drive Circuits, Other Mechanical Elements of a Single Motor
Cost	Dependent upon Cost of Amplifier, EH Valve, Feedback Transducer, D/A Converter, Valve Manifold, Provisions	Dependent upon Cost of Step Motor, Drive Circuits, Valve Manifold, Mounting Provisions
Weight	Usually Less than 1 Pound for EHV	High Slew Speed. Stepper Motor Weight is about 7 Pounds (present state-of-the-art)

Figure 20 Closed-Loop EHV Servo Versus Open-Loop EHPM

Open loop operation of an EHPM requires safeguards against loss of pulses. If the motor misses an input pulse, system positioning accuracy is impaired. The magnitude of the error is directly proportional to the number of pulses lost.

It is postulated that because of improved reliability of electronic circuits, that loss of pulses will be a remote occurrence if the system is operating within its design regime and it appears feasible to shift regimes during operation to keep the system within an operable range. It also is feasible to shut the system down if an operable regime is exited.

Using Reference 5 as a guide to the closed loop control of stepper motors, it is concluded that open loop control with fault monitoring is the better approach. Closed loop control, however, does allow higher speeds and provides more positive positioning integrity. The complexities introduced, however, detract from its appeal. For example, closed loop control requires a feedback transducer, usually an optical encoder disk, which supplies the necessary information to close the loop. To determine the proper rotor positions at which phase switchings should occur requires either a fixed encoder slot/motor detent position angle or the introduction of a time delay circuit in the feedback path. Dual sensors are required for direction sensing. Finally, speed of the closed loop servo is quite sensitive to load variations. Since the motor load varies directly as a function of speed, the closed loop control would involve additional complexity to control slewing speeds. These disadvantages led to the exploration of fault monitoring schemes for improving positioning integrity. The open loop system was examined to determine criteria for pulse positioning integrity. In order to avoid loss of pulses, the following criteria must be met.

- o Stepper motor torque must be sufficient to drive valve under all operating conditions.
- o Hydraulic motor flow must be sufficient to provide the commanded motor velocity.
- o Hydraulic motor supply pressure must be adequate to supply load torque.
- o Motor resonance velocity versus load combinations must be avoided.

It is obvious that mechanical failures within the EHPM or the actuation mechanical system could produce conditions in which the criteria for positioning integrity could not be met. For these eventualities, special monitoring provisions must be supplied. The non-failure states should also be investigated to determine if the above criteria could be met. Areas open to question are: 1) Cold temperature operation, 2) Step motor resonance conditions.

Tests will validate normal operational capabilities of the EHPM system. The rationale for concern at low temperature involves hydraulic fluid viscosity which increases line drops and results in lower available pressures and flows. Motor specification data reflect no resonance zones, and analytical determination of such conditions is of sufficient difficulty to warrant experimental test results to reveal latent resonance zones.

Several industrial users of open loop EHPM's utilize a simple monitoring scheme to automatically shutoff the unit whenever pulse positioning integrity cannot be met. It consists of switch contacts mounted in the gearbox between the step motor and control valve. As the spool is displaced beyond a predetermined overtravel, the switch contacts are closed sending a signal to either shutdown or slow down the input pulse rate.

A straightforward concept such as this one used for industrial controls can be successfully employed in a utility aircraft system such as the flap system. Most failures in the drive system will result in a hardover control valve spool. Using this insight into system operation, switch contact points can be positioned so that contact is made when the valve spool has traveled a predetermined distance beyond the full open position. The making of the switch contacts generates an interrupt signal in the micro-computer which halts the pulse train and provides pilot warning through the existing annunciation system.

To complement this monitoring system, an asymmetry detection system may be employed. It consists of shaft encoders mounted on the flap drive torque tubes in the left and right wing. A critical difference between the left and right shaft encoder results in automatic shutdown and engagement of the drive shaft brakes which lock the flap system in position. This system detects faults in the structure between the drive motor differential and the flap surfaces.

In order to protect the input drive system from failures, redundant input sensors, micro-computers, and power drive circuits can be configured. The prototype system, however, is a single system and is subject to single failure points in the input drive system.

SECTION III APPLICATION SURVEY

One task of this program is to survey the C-5 or similar aircraft for possible uses of the EHPM concept in utility and secondary flight control systems. To perform this task comprehensively and effectively it is necessary to recognize useful alternatives some of which involve use of new technology and to consider the EHPM concept in its larger scope - i. e. combined with its digital computer. The following items are specifically noted:

- o The approach is applicable to the control of linear hydraulic actuators as well as hydraulic motors. One linear actuator device, described in reference 6, consists of a hydraulic actuator with a screw mounted axially through the head end and then through the piston into the rod, arranged so that the screw is rotated by the linear motion of the piston. The rotary motion of the screw is used as the feedback in the same way that the rotary motion of the hydraulic motor is used in the EHPM. The actuator can be called an electrohydraulic pulse actuator, EHPA, to distinguish it from the EHPM.
- o A black box which incorporates a digital computer which may be multiply redundant can control one or more subcircuits or parts of subcircuits. This box can control any subcircuit which lies within its capacity range and the only difference between two black boxes controlling different subcircuits is the ROM (read only memory) program. That is, the hardware is identical. It is therefore, predicted that such a black box will be a functional standard and will be used to control different subcircuits in the same airplane and in different airplanes. This broad usage will lead to significantly lower costs than normal for black boxes. This prediction is substantiated by the story of the electronic slide rule.
- o Two or more actuators using the same pulse stream for control will operate in synchronization - i. e. their displacements will correspond. This type of control has in the past been difficult to achieve and has usually resulted in a mechanical tie between actuators. When using the EHPM approach with an encoder the encoder outputs are compared and can make adjustments or stop the system if the actuators exit synchronization.
- o Adding control parameters to a circuit increases the complexity of the system only to the extent of the input signal, e. g., a pressure transducer and its wiring. The circuit to multiplex, digitize, and read many inputs is assumed to exist in the standard black box.
- o Adding an EHPM or EHPA to the system involves adding the actuator, its driver, an encoder if used, and interface functions which are standardizable.

Lockheed's cargo aircraft were surveyed to determine where the EHPM/EHPA concept would be a viable alternative if the aircraft were being designed within the next decade. This survey revealed the following candidate applications:

<u>SUBSYSTEM</u>	<u>IS EHPM/EHPA A VIABLE CANDIDATE?</u>		
	<u>C-5</u>	<u>C-141</u>	<u>C-130</u>
Thrust Reverser	YES	NO	NA
Landing Gear and Door Actuation	YES	YES	YES
Nose Gear Steering	YES	YES	YES
Kneeling System	YES	NA	NA
Cross Wind Gear Positioning	YES	NA	NA
Aft ramp actuators	YES	NO	NO
Visor Actuator	YES	NA	NA
Flaps/Slats	YES	YES	YES
Winch Control*	YES	YES	YES
Petal Doors	YES	YES	NA
Stabilizer	YES	YES	NA
Stabilizer Trim	YES	YES	NA

* When used for special mission aircraft - not on all aircraft

Additional candidate applications which are used in other aircraft are as follows:

- Radar drive
- Wing fold
- Wing sweep
- Bomb bay doors**
- Gun drives

Comparative Analysis

In evaluating the viability of the concept for each of these applications it is necessary, to evaluate the following factors:

- o Procurement Cost
- o Maintenance Cost
- o Weight
- o Reliability

Safety is not listed since it is assumed that adequate safety is built in before the above are considered.

As it is not feasible to perform quantitative analyses for this generalized evaluation a discussion of the factors is presented.

Procurement Cost - the concept transfers the bulk of the control functions from the hydraulic circuit to the electronic circuit. The hydraulic valving complexity is significantly reduced. The electronic circuitry is standardized in easily replaceable modules. The number of LRU's (line replaceable units) in the system is significantly reduced and the ones that are required can be identical for many subcircuits. The effects of standardization - larger quantities of fewer pieces will result in lower costs to specify, procure, test, develop, store, and install.

Maintenance Cost - the simpler hydraulic circuit and the modularized electronic circuit coupled to the multiply redundant computer which can self test to identify faulty modules offers a real opportunity to reduce maintenance costs. Fewer parts leads to reduced logistics costs.

Weight - weight for most of the applications will be less than the present approach primarily because of less valving and plumbing.

Reliability - The number of moving parts in the systems is dramatically reduced, and the degree of redundancy in the control is increased. Many limit switches may be eliminated.

It is predicted that dramatic improvement in the maintenance and reliability factors and significant improvement in the procurement cost and weight factors can result.

SECTION IV PROTOTYPE EHPM DESIGN

Selected Actuation System

The existing flap control and actuation system involves a complex of mechanical, hydraulic, and electrical devices and was designed and arranged using the available technology at the time the C-5 was developed. A hypothesis leading to this study is that dramatic developments in electronic circuitry especially in the computer field can lead to significantly improved control and actuation systems. An approach being considered is to accumulate as much of the control as possible within a digital computer and simplify to a maximum the hydraulic valve system and the electrical controls. The C-5 flap and slat actuation system offers an attractive arrangement for making a comparative study and for evaluating a prototype system. The hydraulic control is sufficiently complex that substantial simplification can be demonstrated. Further justification for this selection is provided by the availability and adaptability of the C-5 Iron Bird for prototype testing. The full size simulator provides actuation hardware including gearboxes, torque tubes, actuators, and load simulation equipment.

The elements of the C-5 flap system are indicated in Figure 21. The torque requirements for the hydraulic motor are shown in Figure 22. The various speed and gear ratios used in the system are provided in Figure 23.

Description of a Projected System - The elements of a system to do the same job as the C-5 flap and slat system using current and projected technology is shown in Figure 24 which also indicates the prototype test system. In this arrangement, the crew input is a dual electronic signal from the flap control handle. Each of the two drive packages is controlled by an electronic package which is a digital computer plus associated electrical circuitry related to the power delivered to the stepper motor drive. The electronic control reads the various input devices which are the crew input, the motor output, the gearbox output, the asymmetry detectors and hydraulic pressures, and on the basis of these inputs, controls a stream of electrical pulses to the stepper motor that drives the hydraulic motors. The electronic control also delivers signals to the hydraulic insulation valves and to the asymmetry brakes on the basis of the inputs which it has read.

Much of the circuitry in the electronic control is projected to be form and function standard. It will not be circuitry which is specifically developed for this special task. It consists of a standardized CPU, ROM, and RAM plus some specialized circuitry. (CPU = Central Processor Unit; ROM = Read Only Memory; RAM = Random Access Memory)

It is the ROM circuitry which adapts the standard hardware to the specialized task of controlling the flap system. The ROM hardware is standard but its numerous elements are programmed -- positioned permanently or semi-permanently. The ROM provides the information which defines how the CPU will handle the information it reads from the various inputs and from the RAM. The RAM is variable memory and is temporary in nature.

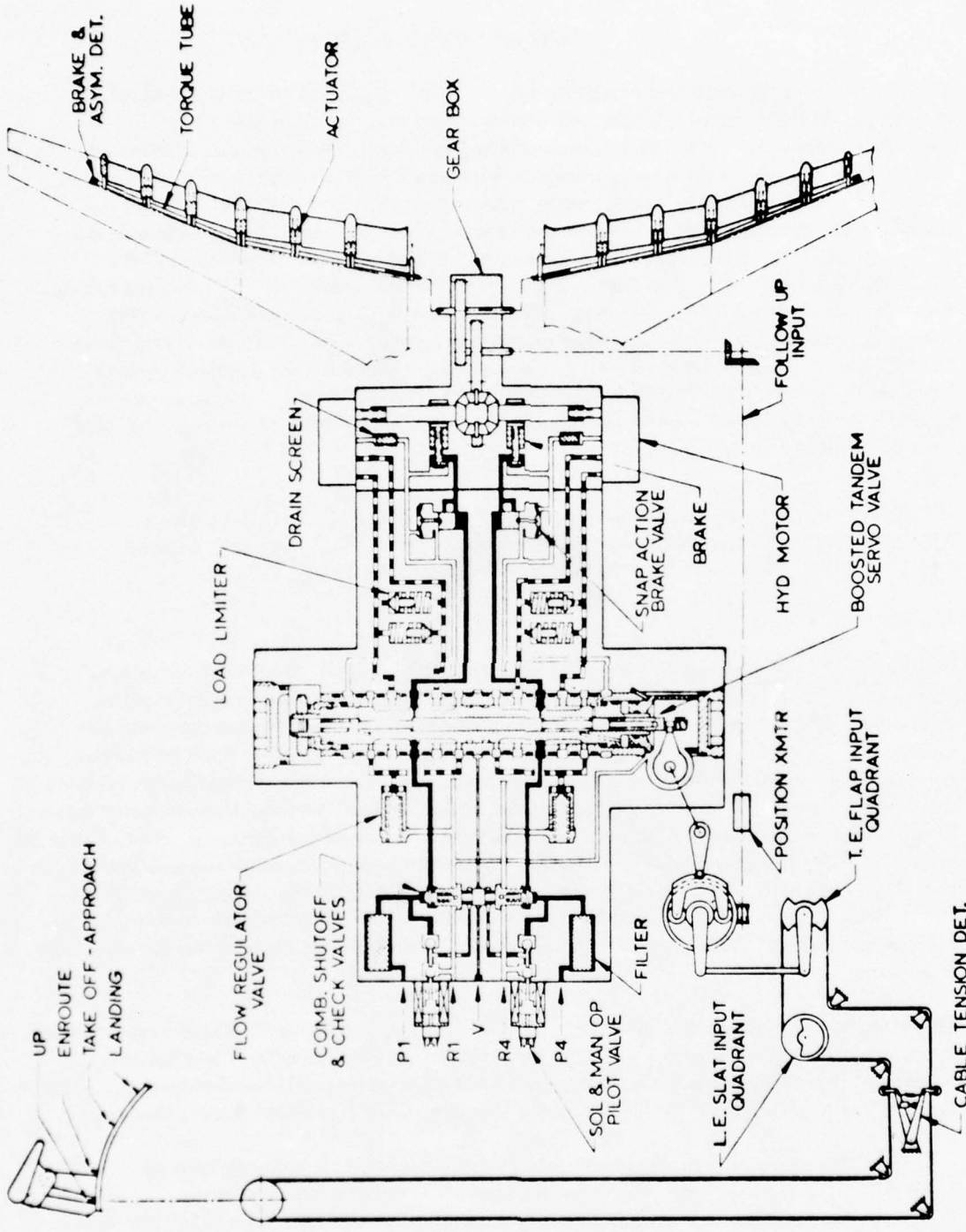
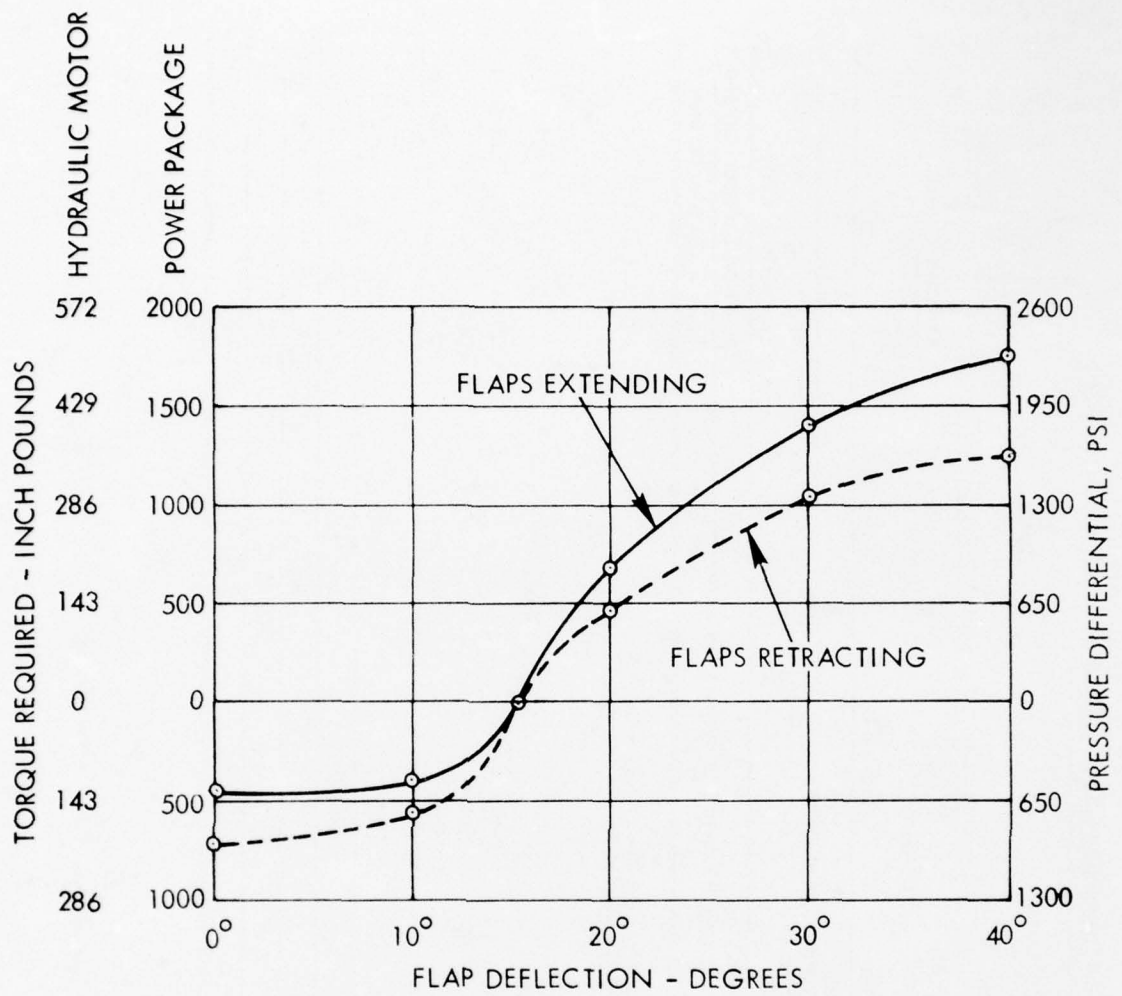

Figure 21 C-5 Trailing Edge Flap Schematic



NOTE: PRESSURE DIFFERENTIAL ACROSS 1.52 IN³/REV MOTOR WITH OVERALL EFFICIENCY OF 0.9 FOR MOTOR/GEAR BOX PACKAGE TO PROVIDE TORQUE INDICATED. MOTOR TO POWER PACKAGE GEAR RATIO 3.5/1.

Figure 22 Flap Load Vs Deflection

POWER PACKAGE DATA

<u>Shaft</u>	<u>Revolutions Required to Extend</u>	<u>Speed (RPM)</u>	<u>Ratio to Output Shaft</u>	<u>Remarks</u>
Output Shaft	526.19	1127.64	1:1	
Hydraulic Motors	1841.665	3939.74	3.5:1	
Worm Shaft	21.925	45.8	24:1	Shaft that drives position comparison shaft
Position Comparison Shaft	315.720	1.83	600:1	Position Comparison shaft
Input Lever	103.500	0.602	1830:1	Follow Up Mechanism

ACTUATOR ASSEMBLY DATA

<u>Shaft</u>	<u>Input Revolutions Required to Extend</u>	<u>Input Speed (RPM)</u>	<u>Ratio Input to Output</u>	<u>Output Speed (RPM)</u>	<u>Output Revolutions Required to Extend</u>
No. 1 Tee Box	526.19	1127.64	1.0589:1	1064.92	498.29
Step Gearbox	493.29	1066.92	1.875:1	514.626	265.043
2 Through 4 Gearboxes	526.19	1127.64	1.9853:1	514.626	265.043
5 and 6 Gearboxes	526.19	1127.64	2.4545:1	460.	214.377
7 Through 12 Gearboxes	526.19	1127.64	2.68181:1	420.	196.207

Extend Time: 28.0 ⁺⁰/₋₅ Seconds

Figure 23 Flap System Data

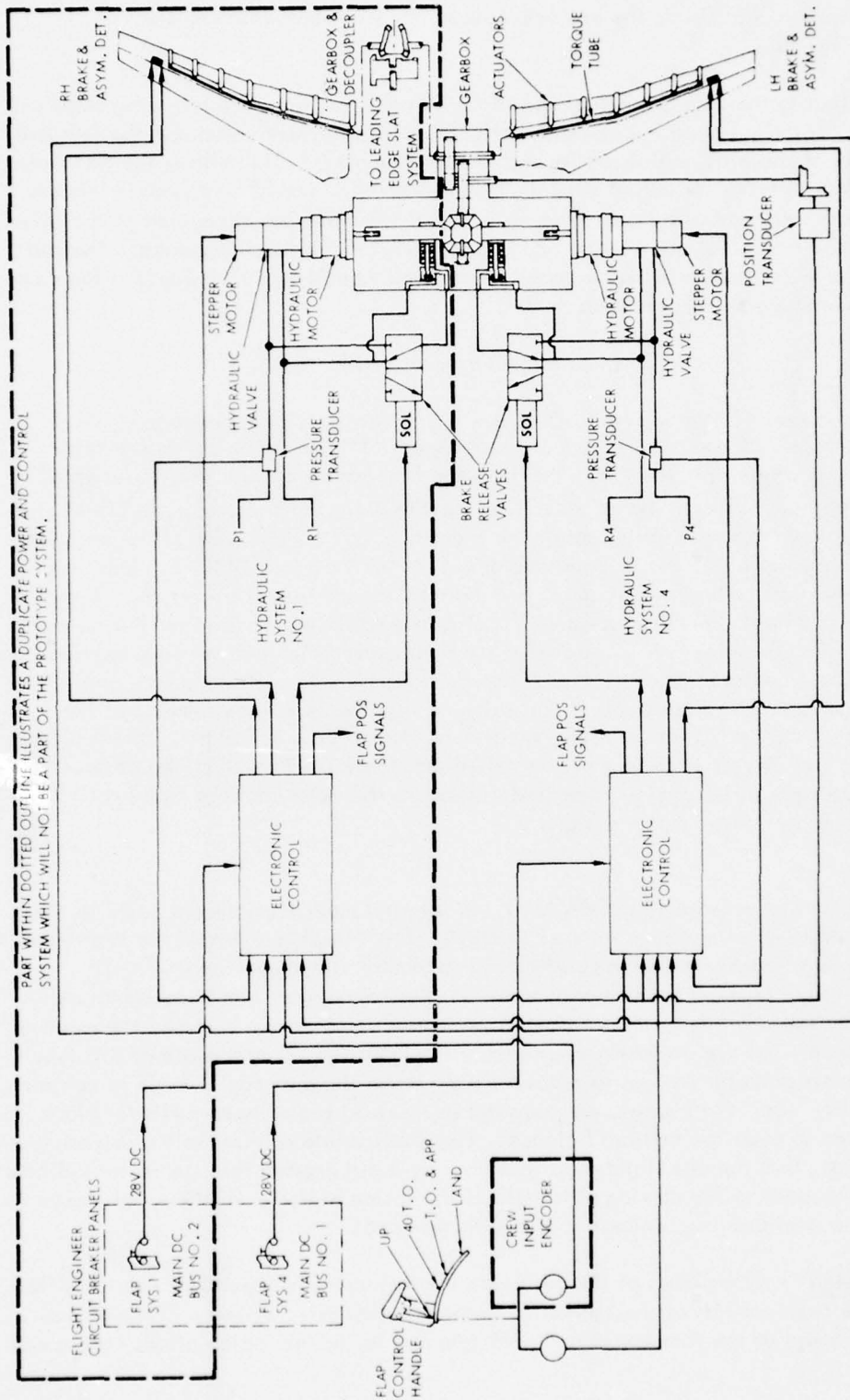

Figure 24 System Arrangement for Prototype Testing

The fact that the electronic control can be produced in a small size, at low cost, and with high reliability is the key technology advancement which makes this approach feasible.

Modification to the flap drive package to facilitate using only the left wing flaps is required. The right hand hydraulic motor and brake are deactivated and the left and right gears of the differential are locked to the same shaft. This allows the left motor to drive the differential output gear at the same speed it would be driven if left and right motors were operating and since only 1/2 of the flaps are connected to the drive torque tube, the left motor will carry its normal 1/2 of the total flap load. The test drive motor will, therefore, be exposed to the same conditions as if would if the complete system were being operated.

Motor/Valve Assembly

Motor Selection - The present C-5A flaps are driven by Vickers bent-axis 3915-30 motors. These motors have a displacement of 1.52 cubic inches per revolution, and a single unit will drive all the wing flap panels on one wing. An equal displacement axial piston motor is selected for the design of the prototype EHPM unit. The axial piston design is selected for the simplicity and compactness of the complete motor/valve assembly. The selected motor is the ABEX model AM8C-2. This unit is presently in production for the Boeing 747 on the inboard flap drive system. A similar model, with slightly less displacement, is also in production for the F-111 wing sweep. The model AM8C motor is fully qualified for both commercial and military applications. An assembly drawing of the AM8C-2 is shown in Figure 25. Performance curves for this unit are shown in Figure 26. Referring to the flap load requirements of the previous section the highest pressure required at the motor is 2,362 psi. Since identical size motors drive the present and proposed prototype EHPM system, no problem related to torque sufficiency is expected. Analysis indicates that the flap application does not require a servo motor design.

In the design of the prototype EHPM unit, no internal modifications are made to the standard AM8C-2 unit except for seal changes. The design features of the motor/valve interfaces can be seen in the complete EHPM assembly drawing, Figure 27. To adapt the valve housing to the standard motor, the normal port cap is removed and is replaced by the valve housing. A port plate is used to interface between the rotating cylinder block and the stationary aluminum valve housing. A port plate of this type is used in many pump or motor designs to reduce weight when the port cap is large or contains additional valves. No changes are required in this port plate/motor cylinder block porting area to alter the critical balance. The spool spline driving unit is driven through a radial slot, that permits slight misalignment, by a pin pressed into the motor cylinder block. The spool spline driving unit utilizes the inside diameter of the spool sleeve as a bearing thus maintaining concentricities with the spool.

Valve Design - The design of the prototype control valve is dependent upon the flow and torque requirements of the hydraulic motor and flap drive system. The maximum operating speed of the flap system is 3,949 rpm and for further calculations, the speed

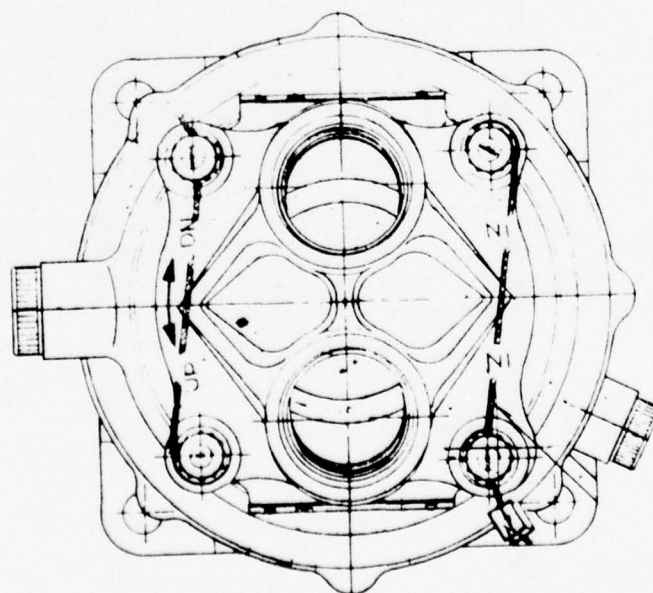
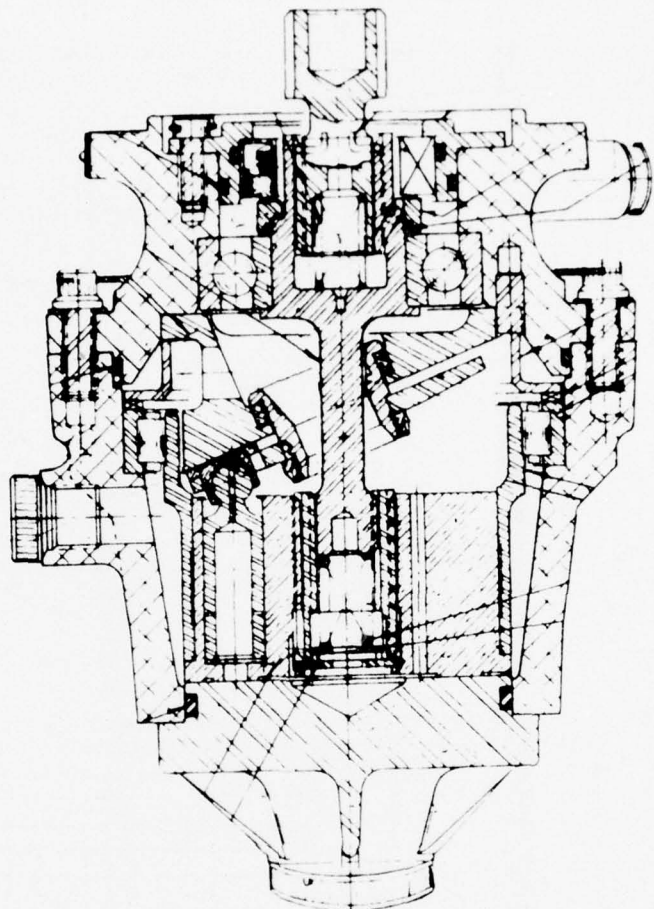

Figure 25 Hydraulic Motor, Abex Model AM8C-2

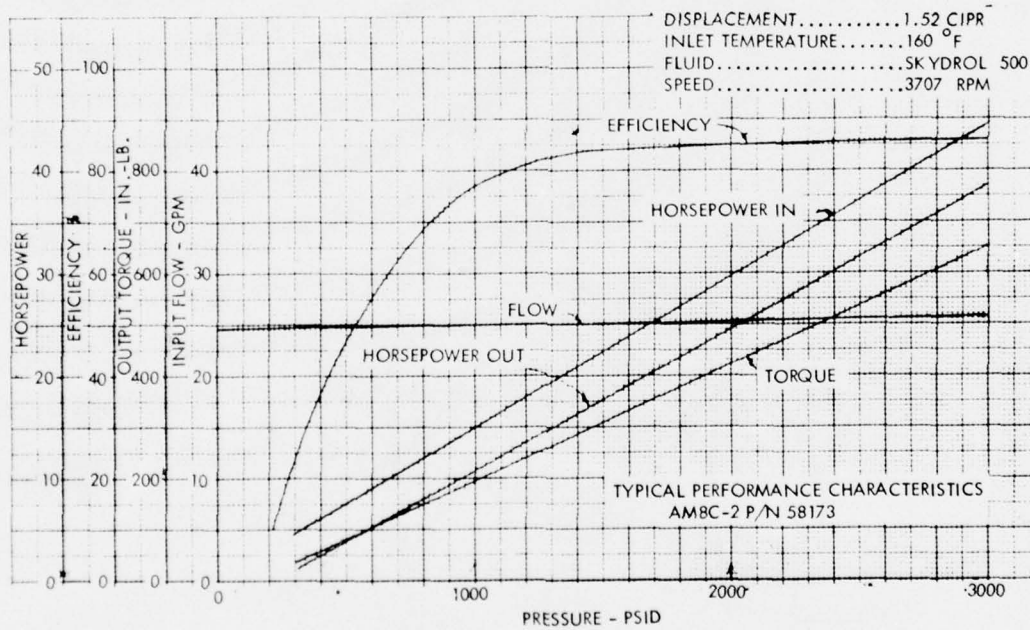
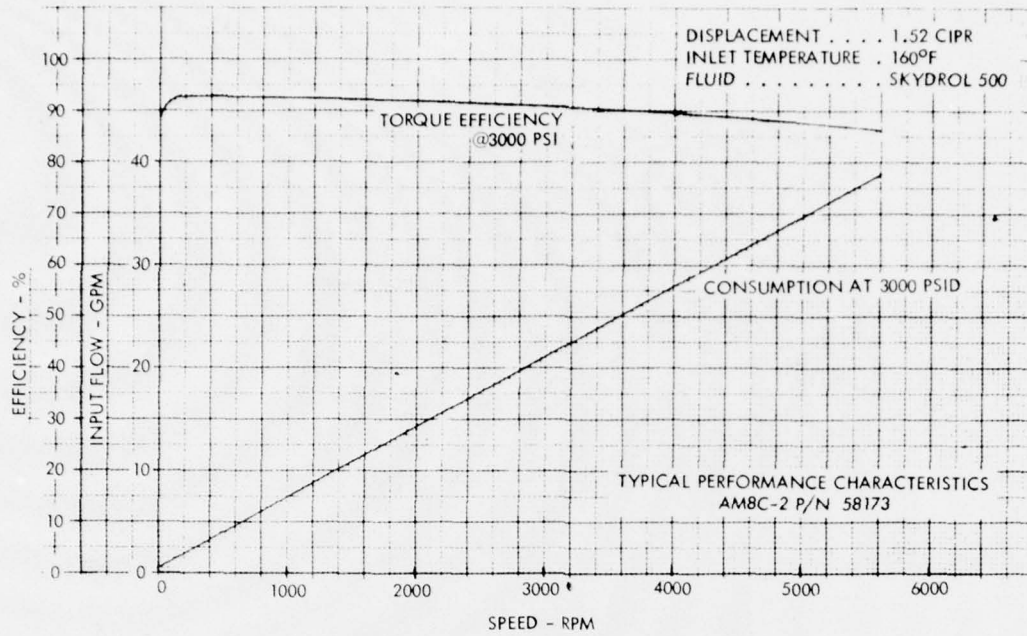

Figure 26 Hydraulic Motor Performance

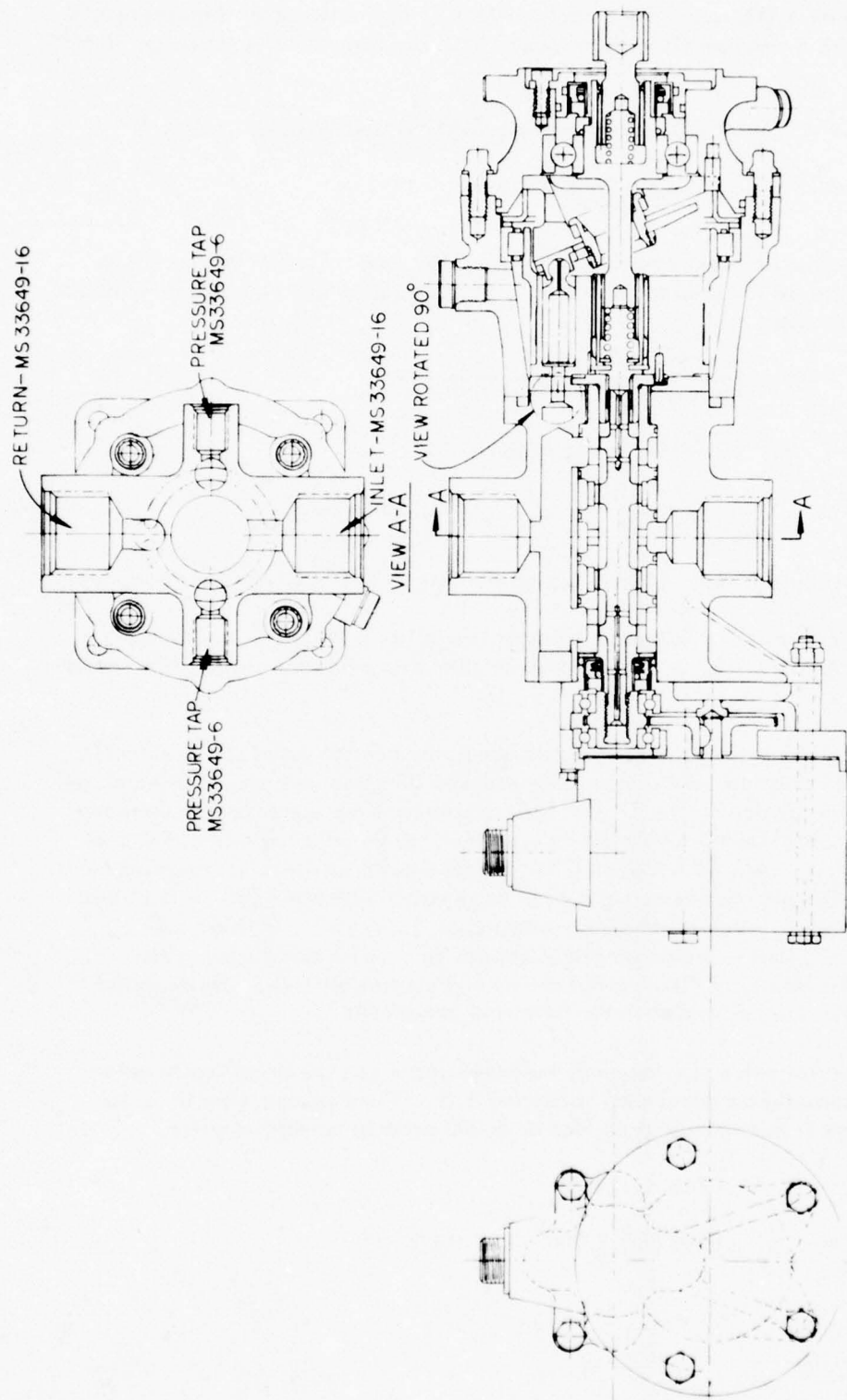

Figure 27 Electrohydraulic Pulse Motor

is considered to be 4,000 rpm. The selected AM8C-2 hydraulic motor displacement is 1.52 in³/rev with a volumetric efficiency of .97. The control valve maximum flow is:

$$Q = \frac{\text{Displacement} \times \text{speed}}{231 \times \text{efficiency}}$$

$$\text{or } Q = \frac{1.52 \times 4,000}{231 \times .97} = 27.1$$

The motor output torque requirement of the flap drive system is shown in the previous section. The pressure required at the motor to develop the torque can be determined by the following equation:

$$P \text{ (psi)} = \frac{2 \pi T \text{ (in/lb)}}{\text{Displacement (in}^3\text{/rev)} \times \text{efficiency}}$$

The maximum pressure requirement of the motor is:

$$P \text{ (psi)} = \frac{2 \pi \times 500}{1.52 \times .9} = 2,296 \text{ psi}$$

This maximum pressure is only required during the last 5° to 8° of flap extension.

At all other times, the required motor pressures are below 2,000 psi. In the last 5° to 8° of flap extension, the motor drive may be slow to provide the required increased load pressure.

With the flow and torque requirements established, the control valve size is selected from the group of standard valve sizes. The standard 25 gpm valve size is selected for the basic valve dimensions. The 27 gpm flow requirement represents an 8% increase in flow with slightly higher valve pressure drop that can be adjusted in the design of the control orifices. An ABEX Model 425 electrohydraulic servo-valve designed for a rated flow of 25 gpm incorporates a second stage valve with basic dimensions almost identical to the 25 gpm valve standard developed in this study. This Model 425 valve was selected for the prototype EHPM control valve with modifications for incorporating the translator drive, spool drive, and control orifices. The design of these modifications are discussed in the following paragraphs.

The selected control valve is a four-way balanced valve and the equations to determine the flow forces were developed in Section 3.0. The maximum flow force for the 27 gpm valve is determined at no load or 3,000 psi drop across the valve.

$$F = .0246 Q \Delta P_v$$

$$= .0246 (27) 3,000 = 36.38 \text{ lbs}$$

This valve flow force is transferred to torque through the selected thread and gearing of the translator. The standard valve translator thread size can be either a 5/16 x 14 Acme or a 5/16 x 18 course thread. The 5/16 x 14 Acme thread was selected for the prototype design. The torque can be determined by the equation developed in the section on translator design. The torque requirements for a standard 25 gpm valve is 10.1 inch ounces and since the flow forces and torques are directly proportional to flow, the torque requirement of the prototype valve of 27 gpm is increased by a ratio of 27/25 x 10.1 or approximately 11 inch ounces.

Valve Stroke Versus Flow Selection - As determined by the stability analysis which follows, a valve gain of 40 should not be exceeded. This requirement pertains to operation near the shutoff regime. After the valve is open to some degree, it is allowable to increase the gain. The selected stroke versus flow requirement for valve manufacture is shown in Figure 28. For this figure, the ΔP across the total valve is held constant at 3,000 psi until design flow is obtained and then the flow is held constant while the valve is opened to its maximum. Differential pressure, of course, has to be reduced as the valve is opened so as to maintain constant flow. At valve full open, the total ΔP across the valve is 500 psi. As determined previously in this section, the required ΔP for the hydraulic motor itself is 2,296. At valve full open, total ΔP across valve and motor is 2,796 leaving about 200 psi for loss in the hydraulic system.

Servo System Stability Analysis - The servo valve, hydraulic motor, and mechanical feedback linkage form a closed loop servo system. The stepper motor is located outside of the loop and, therefore, its response characteristics are not a part of this analysis. However, since it is the servo valve driver, its response (to accelerate and decelerate) and its maximum speed characteristics should equal or better that of the rest of the servo system.

The stability criterion used for this analysis is a gain margin of 6 db. Military specification MIL-F-9490 calls for a gain margin of 6 db and phase margin of 30°. Since there are no active feedback sensors in the system, it is considered that the phase margin can be neglected. The analysis consists of root locus and frequency response characteristics for a linearized math model of the servo system.

Using the following parameters for the EHPM prototype system, an analysis of the unloaded motor stability is performed. This is comparable to bench operation of the EHPM and is a worst case stability consideration.

V	=	Oil Volume	=	2.5 in. ³
J	=	Hydraulic motor inertia	=	0.0082 lb. -in. -sec. ²
B	=	Adiabatic bulk modulus of oil	=	0.27 x 10 ⁶ lb./in. ²
D	=	Hydraulic motor displacement	=	1.52 in. ³ /rev. = 0.242 in. ³ /rad.
L	=	Total leakage coefficient	=	1.0 x 10 ⁻³ (in. ³ /sec.)/(lb./in. ²)

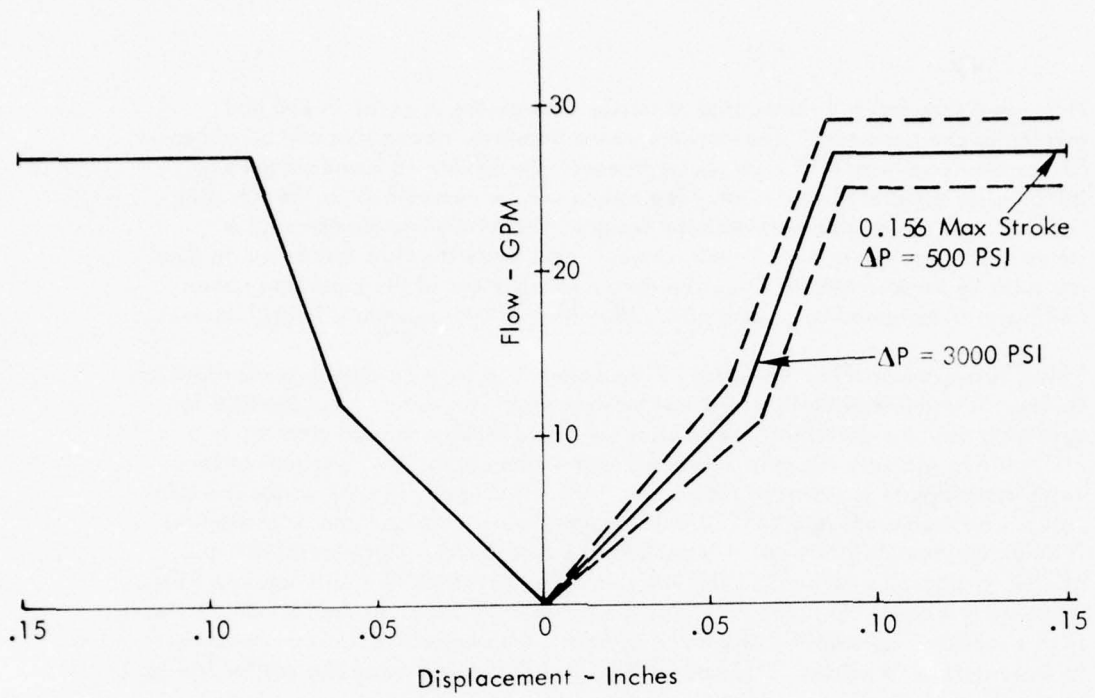

Figure 28 Valve Flow vs Displacement

Root loci were calculated for a variation of loop gain, K_{loop} from 1 to 100 sec^{-1} . The servosystem is quite stable for the entire range of gain variation and for bench operation with the minimal inertia indicated. Natural frequency for this condition is high (approx. 650 rad./sec.) with damping inversely proportional to loop gain.

The effect of adding load inertia is examined.

Choosing a first cut value of loop gain of 40 sec.^{-1} , the load inertia is varied from 0.02 to .09 lb-in-sec.^2 . This corresponds to ground operation of the system for increasing inertia loads. The result of this analysis is seen on Figure 29 (Plot No. 1). In general, the effect of adding load inertia is a reduction of natural frequency and a slight decrease in damping.

The load inertia of the C-5 trailing edge flaps reflected to the hydraulic motor shaft is estimated to be .064 lb.-in-sec^2 . The stability margins of the loaded servo-system are determined. First, a root locus is determined for the servosystem with a conservative load inertia estimate of 0.07 lb-in-sec.^2 , varying the closed loop gain constant from 10 to 100 sec.^{-1} . From the results, also plotted on Figure 29 (Plot No. 2), it is seen that the system goes unstable for gains somewhat above 100 sec.^{-1} . To assure a minimum 6dB gain margin, the loop gain should be held to 1/2 this value or 50 sec.^{-1} . To check stability margins, an open loop frequency response was conducted on the model. The results, plotted on Figure 30, show gain margin of 8.68 db and a phase margin of 87 degrees using a gain of 40 sec.^{-1} . Therefore, the stability criterion of 6 db gain margin is met.

The effect of hypothetical hinge moment loads was then examined. To simplify the problem, the flap system hinge moment coefficient was considered to be constant at 0.0432 in-lb/rad . A root locus of the inflight configuration of Figure 29 (Plot No. 3) was solved for loop gain variations related to the ground operation gain variations. The results show that the system response, for any load inertia or gain variation, remains essentially unchanged for the air spring loads under consideration here, 0 to 0.15 in-lb./rad .

Stepper Motor and Gearing

Load Analysis and Gearing Requirements - A most important consideration in the selection of a motor is the analysis of the motor load, both running torque and inertial torque. The valve flow torque load was calculated at 11-inch ounces at 27 gpm (4,000 rpm). In addition the friction and inertia loads may double the pulse motor torque requirement.

A review of available EPM's, on the previous "baloney" chart, Figure 2, shows that few manufacturers can meet the speed-torque requirements. Performance data for candidate motors from three manufacturers are shown in Figure 31. Stepper motors were chosen

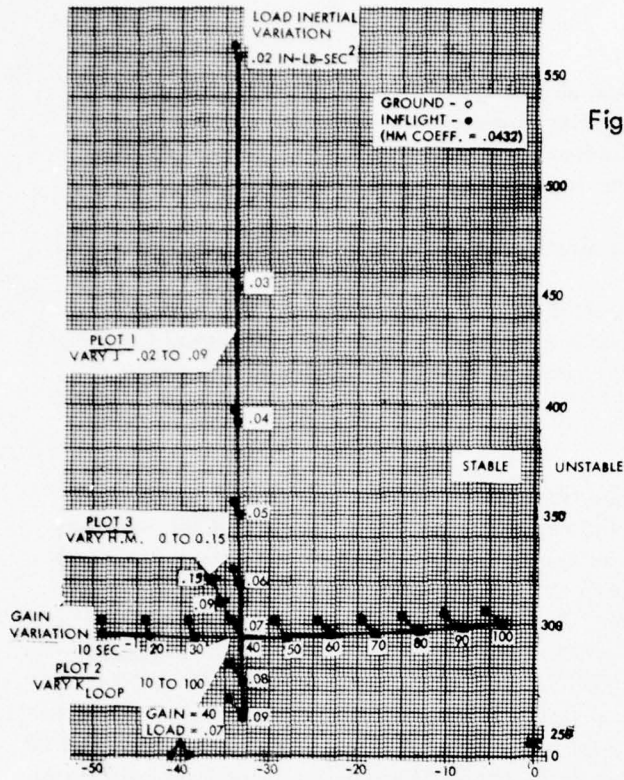

Figure 29 S-Plane Root Loci, Hydraulic Servo Systems

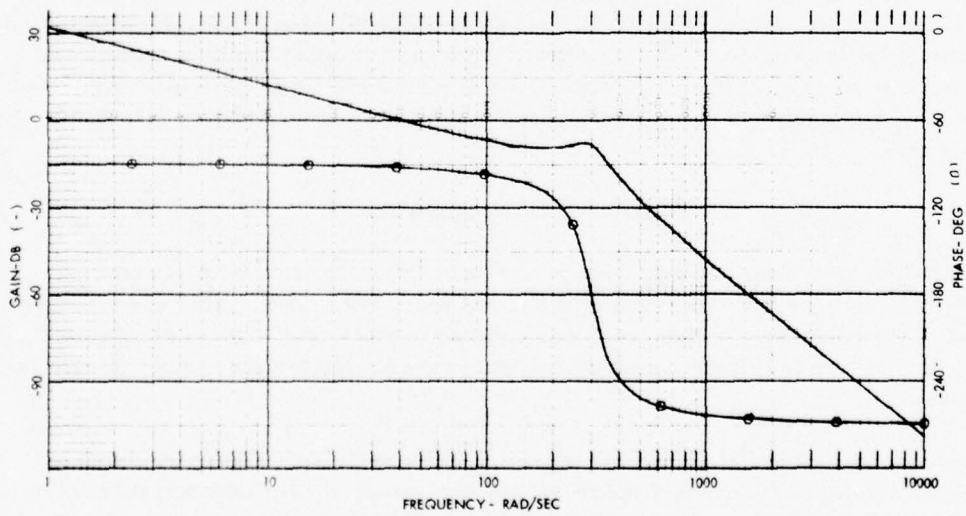

Figure 30 Open Loop Frequency Response

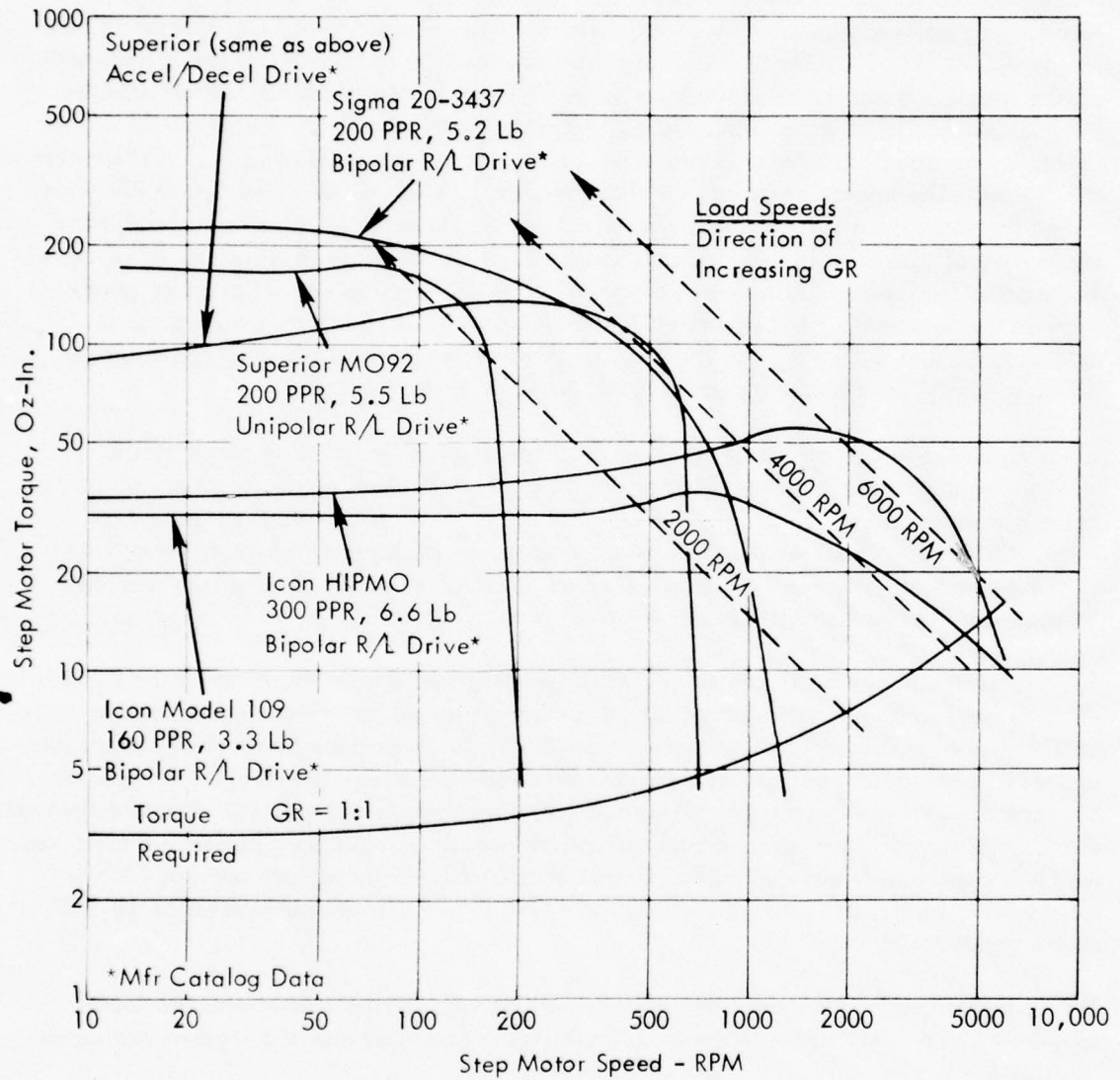

Figure 31 Candidate Step Motor Speed-Torque Characteristics

for this figure based upon advertised speed-torque characteristics with an upper limit placed on the weight of the unit of 10 pounds. The figure indicates that without resorting to gearing, only the Icon unit can meet the design point, motor load 11 oz. in. at 4,000 RPM (10,000 PPS). The effect of input drive circuit choice is also noted on the graph. It can be seen that the Superior Electric Motor M092, which is being used in SAAM EHPM units with success, exhibits greatly increased capabilities when driven by an accelerate/decelerate drive unit. The effect of gearing is also shown on the figure. The operating points for three speeds, (2,000, 4,000, and 6,000 RPM) are shown for increasing gear ratios. The effect of increasing gear ratio does present the possibility of operating the Superior M092 unit with accelerate/decelerate drive units. The margin for load estimate error, however, was not considered sufficient to pursue such an arrangement. It is pointed out that the only unit capable of operation at speeds as high as 6,000 RPM is the Icon Hi PMO motor. This unit with gearing can drive an EHPM for overspeeds up to 6,000 RPM for test purposes.

Gearing between the stepper motor and load can reduce the running speed of the motor. In addition to the small losses due to gear inefficiency, gearing does present certain disadvantages. It changes the output shaft rotation per input pulse of the hydraulic motor. Gearing also requires increased motor torque in direct proportion to the gear ratio, and inertia loads reflected back to the motor through the gear are increased by the square of the gear ratio.

The selected stepper motor (Icon Hi PMO) speed-torque capability is shown on Figure 32 with load torque requirements plotted for 5 gearing ratios. The abscissa of the plot is shown in both RPM and pulses per second. This was done because of an imposed upper limit of 10,000 pulses per second input command rate^m. This limit was imposed because the input pulse train is being generated by the microcomputer. It was estimated that a minimum of 100 μ s of computation time would be necessary between each pulse, which is equivalent to an upper limit pulse rate of 10,000 pulses per second. A gear ratio of 1.2 results in rated load speeds of 4,000 RPM for input pulse rates of 10,000 pulses per second.

The torque difference between the motor speed-torque characteristic and the load torque characteristic curve is the torque available to accelerate the load to overcome inertial loads.

The upper limit of load inertia allowable for the Hi PMO motor as published in the motor specification data is 3.5×10^{-4} lb-in-sec². The inertia calculations which follow this paragraph show that the stepper motor load inertia expected for the prototype systems is 2.17×10^{-4} in-lb-sec² which leaves a margin of 38%. The primary contributor to this value is the two inch diameter gear on the motor shaft which has an inertia of 1.8×10^{-4} in-lb-sec². The reflected inertia of the control valve spool is negligible. (Note: After fabrication and test of the prototype EHPM the motor inertia load was recalculated to be 4.5×10^{-4} in-lb-sec². The increase was due to the addition of the translator nut and bearing inertia. The increased inertia increased the acceleration time constants experienced in the prototype testing).

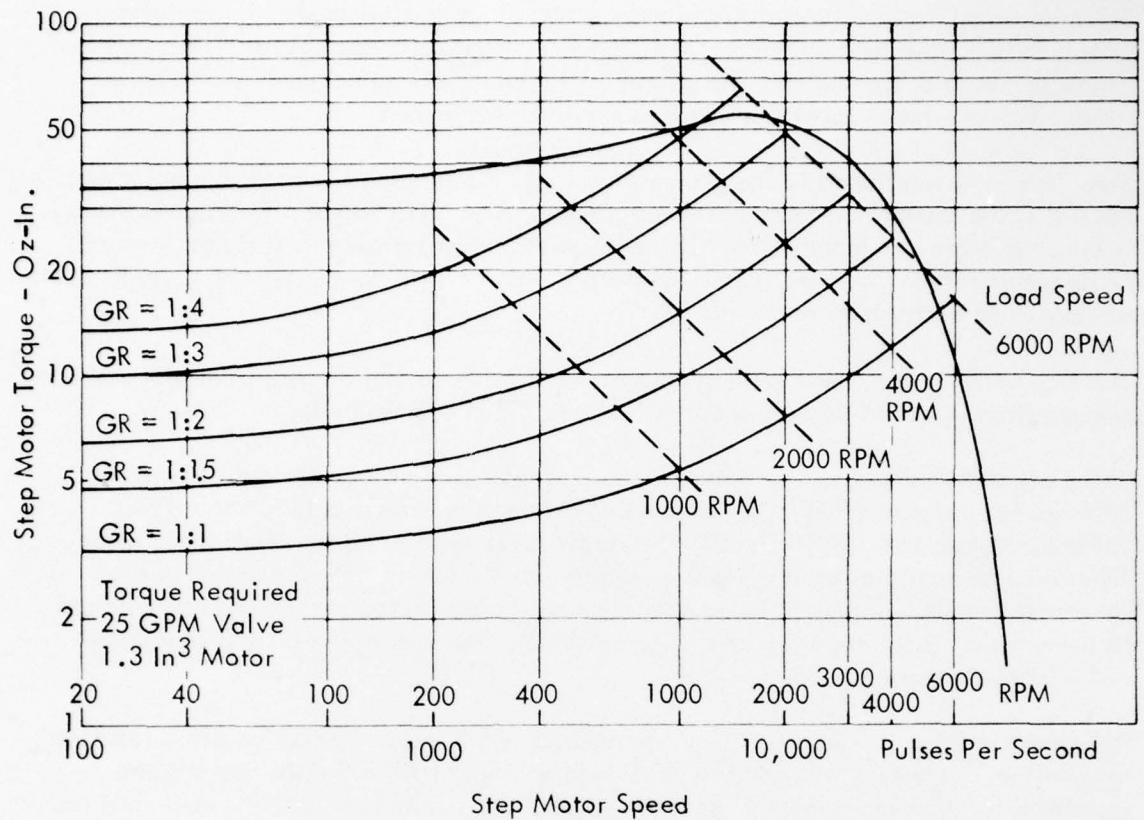

Flow Torque - $T_F = 2.2 \times 10^{-3} n$ where n = valve speed in RPM
 Shaft Seal - $T_S = 3.12$ oz-in.
 Total Load = $(T_F + T_S)/GR$ where GR = Step Motor Speed/Valve Speed

$$= \frac{3.12 + 2.2 \times 10^{-3} n}{GR}$$

Figure 32 Speed-Torque Characteristic, Icon HI PMO Step Motor, 6.6 Lb, 300 PPR

Since an acceleration/deceleration ramping technique is planned for the prototype system to bring the load to rated speed, it is important to investigate the time constants which can be programmed into the microcomputer software to accomplish the pulse ramp. Typical ramp format was shown previously in Figure 8.

Step Size - As mentioned in the previous section, the gearing between the motor and control valve assembly affects system resolution. The other factor affecting resolution is the step angle per input pulse. The EPM selection was made primarily on the basis of its speed-torque characteristic. Resolution was not important, it being several orders of magnitude better than required.

The flap angle is not linear with hydraulic motor position and the maximum slope of the flap position vs pulses delivered curve is about .0004 degrees/pulse.

There are other advantages to having a small stepping angle besides resolution. An EPM has several operating modes depending on stepping rate and load conditions. These modes are the stepping mode, the transitional mode, and the slew-speed mode. Operation of utility aircraft systems is usually accomplished with the motor in the slew-speed mode. The stepping and transitional modes are purposely avoided because of the erratic, jerky motion imparted to the load. The step angle affects the granularity of the response.

Environmental Considerations - The most critical environmental consideration is motor temperature. Motor windings have temperature ranges within which they operate satisfactorily dependent upon class of insulation used. Normally MIL-Spec motors use Class H insulation which allows a rated motor temperature of 130°C. Exceeding this value reduces winding life. Several options are available to provide cooling; namely, encasing the EPM in a cooling shell and blowing with fans, providing fins on the motor, or cooling with hydraulic fluid. During the prototype development program, motor temperature will be monitored and cooling provided if required.

In isolated cases, motors may be used in dirty environments. The "dirt" could be sand or dust, or other contamination detrimental to the motor, such as hydraulic fluid. For these operations, protection of the motor from its environment may be required. Either a protective case or a specially built motor offer a solution to the contamination problem. The EPM selected for the flap drive EHPM system is presently being used in Fujitsu EHPM numerical control application and is provided with dirt and hydraulic fluid contamination protection.

Mechanical Requirements - Principal stepper motor mechanical requirements are mounting considerations.

The physical dimensions of the selected stepper motor are presented in Figure 33.

Input Drive System

Stepper Motor Drive Units - The motor windings are sequentially energized by the driver circuit which consists of the sequence logic, power drivers, and limiters. The step and direction commands are input to the sequence logic where they are converted to base signals for the power drivers. The signals are amplified by the power drivers and routed via voltage and current limiters to the motor windings. Additional discussion of stepper motor drive circuits is provided in Appendix A.

For simplicity and low cost, a series resistance driver is chosen for use in the prototype study. The driver selected is Icon Model 601-T, which is described more completely in Appendix A. The packaging of this unit is not representative of aircraft hardware.

In open loop operation acceleration/deceleration controls are required to ensure that pulses are not lost. For the test program these controls are incorporated in the software of the microcomputer.

Microcomputer - An ALTAIR 8800 microcomputer is used to program the pulse train for prototype EHPM testing. The ALTAIR 8800 microcomputer is discussed in detail in Appendix B. A brief summary of the unit is:

Processor: 8 bit parallel

Maximum Memory: 65,000 words, all directly addressable

Instruction Cycle Time: 2 microseconds

Inputs and Outputs: 256, all directly addressable

Number of basic machine instructions: 78 (181 with variants)

Add/Subtract Time: 2 microseconds

Number of subroutine levels: 65,000

Interrupt Structure: 8 hardware vectored levels plus software levels

Number of auxiliary registers: 8 plus stack point, program counter and accumulator

Memory Type: Semiconductor (dynamic or static RAM, ROM, PROM)

Memory Access Time: 850 ns static RAM; 420 or 150 ns dynamic RAM

Feedback Elements - Encoders are used to provide position signals from the flap handle and the flap drive gear box. The two basic types of encoders are incremental and absolute. The incremental encoder is noise sensitive and loses count when power is interrupted. The absolute encoder is insensitive to noise and power interruptions and senses shaft position without losing its final reference. The absolute encoder was chosen to provide feedback in the flap actuation EHPM system since the reference position must be maintained.

SECTION V
PROTOTYPE FABRICATION
As-Built Configuration, Input System

The input system was fabricated by Lockheed with off-the-shelf hardware and does not represent the packaging which will be used for a production system. The adequacy of input system technology to provide an appropriate package - size, weight, and cost - was a key consideration in establishing this program, but the development of production configurations was not an intent of the program. The details of the input system are presented in Appendix B.

As-Built Configuration, EHPM

The prototype EHPM was manufactured by ABEX Corporation, Aerospace Division, Oxnard, California, Part Number 63085, Model Number SMP8C-1. Drawings of the EHPM installation (63085) and assembly (62285) are shown in Figure 34, Sheet 1 and 2 respectively. Sheet 3 identifies major elements of the valve drive and feedback considered to be the key technology items of the EHPM. Data applying to these assemblies are as follows.

- o Spool and Sleeve Assembly
 1. Material MIL-S-7420 Cond. E (E 52100).
 2. Valve diametral clearance 0.0003 inches.
 3. Valve travel/gain - see figures 42 and 43.

- o Translator Driver
 1. Material - screw (spool) MIL-S-7420 Cond. E (E52100)
nut (nut - gear driven) 440C Cond. A.
 2. Thread - 0.3125-14 Class 4G ACME thread.
 3. Spline - 0.3125 pitch diameter, 10 teeth, 32/64
diametral pitch, 30 degree pressure angle.

- o Gearing
 1. Material - CRES Per QQ-S-763 Class 440C Cond. A.
 2. Gearing - USA standard 20 degree pressure
angle fine pitch involute spur gear,
32 diametral pitch machined to AGMA
quality number 12.

- o Bearings
 1. Light series angular contact bearings preloaded to 50 lbs. with wavy
washer springs.

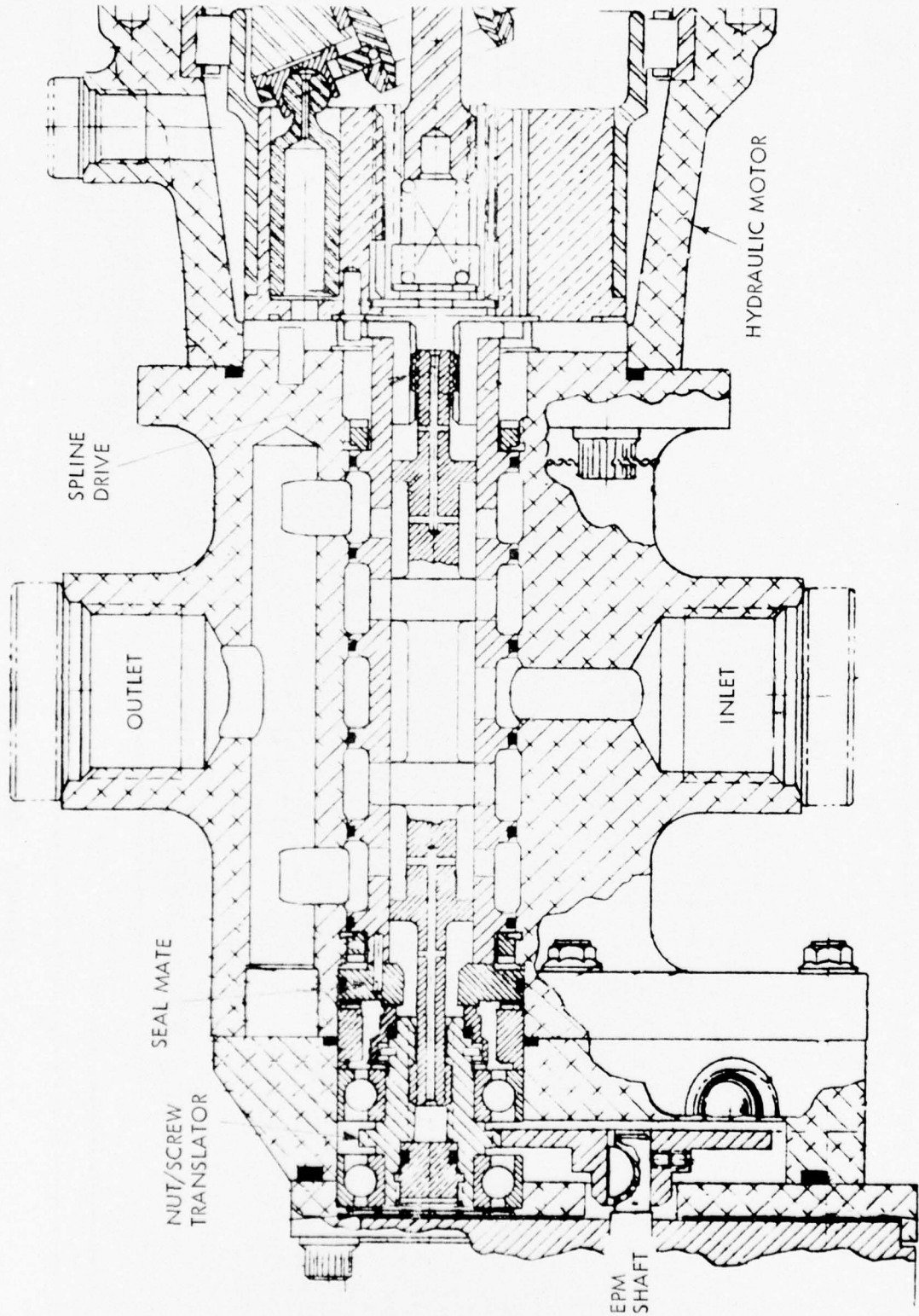

Figure 34 Abex Drawing of EHPM (Sheet 3)

SECTION VI PROTOTYPE EHPM TESTING

Component Tests

Input Drive and Pulse Motor - The input drive system and EPM were developed and tested as a single component. The purpose of these tests was to develop and demonstrate the speed, ramping, and position control requirements of the prototype EHPM actuation system.

The block diagram of the Input Control System is shown in Figure 35. The breadboard test arrangement used as a first verification of software is shown in Figures 36 and 37. A handle geared to the input encoder simulated the pilot's flap control.

Voltage signals simulating the pressure transducer were fed into the interface board to verify that software caused a reduction in EPM speed when pressure fell below 1500 psi, stopped the EPM when below 1200 psi, and provided adequate delay before restarting so that unstable cycling did not occur. This test arrangement served as a test bed for developing and verifying the software and control logic shown in Appendix B.

The apparatus proved to be a most useful tool, and it is believed that the behavior of the EPM output, which is readily observed, can be easily related to the behavior of the EHPM installed in the system, assuming that the hydraulic motor follows the EPM.

Using the control logic and the software program described in Appendix B, the input breadboard arrangement was operated and the behavior of the EPM output was visually observed for proper response. Signals to represent the pressure transducer were fed in using a pulse generator and observed via an oscilloscope. Behavior of the EPM due to simulated pressure signals was visually observed at the EPM output.

For the breadboard development tests there was no data recorded. Success or failure of the test was judged by the observed behavior of the EPM output based on the motion of the input handle and the simulated pressure signals. Failures indicated that changes in the program were required and these were made as the need developed so that when the system behaved properly the testing was considered complete and successful to the extent achievable using the breadboard arrangement.

Speed Control - The speed control requirements were demonstrated. The crew control was moved to some intermediate flap position, the stepper motor accelerated from 0 to 10,000 PPS (2,000 RPM) and ran at constant speed until the selected position was reached, then decelerated and stopped. The control was returned to flaps up position and the stepper motor reversed direction and ran to the UP position with controlled acceleration and deceleration ramps. Effective ramp control was demonstrated when reversing direction of rotation.

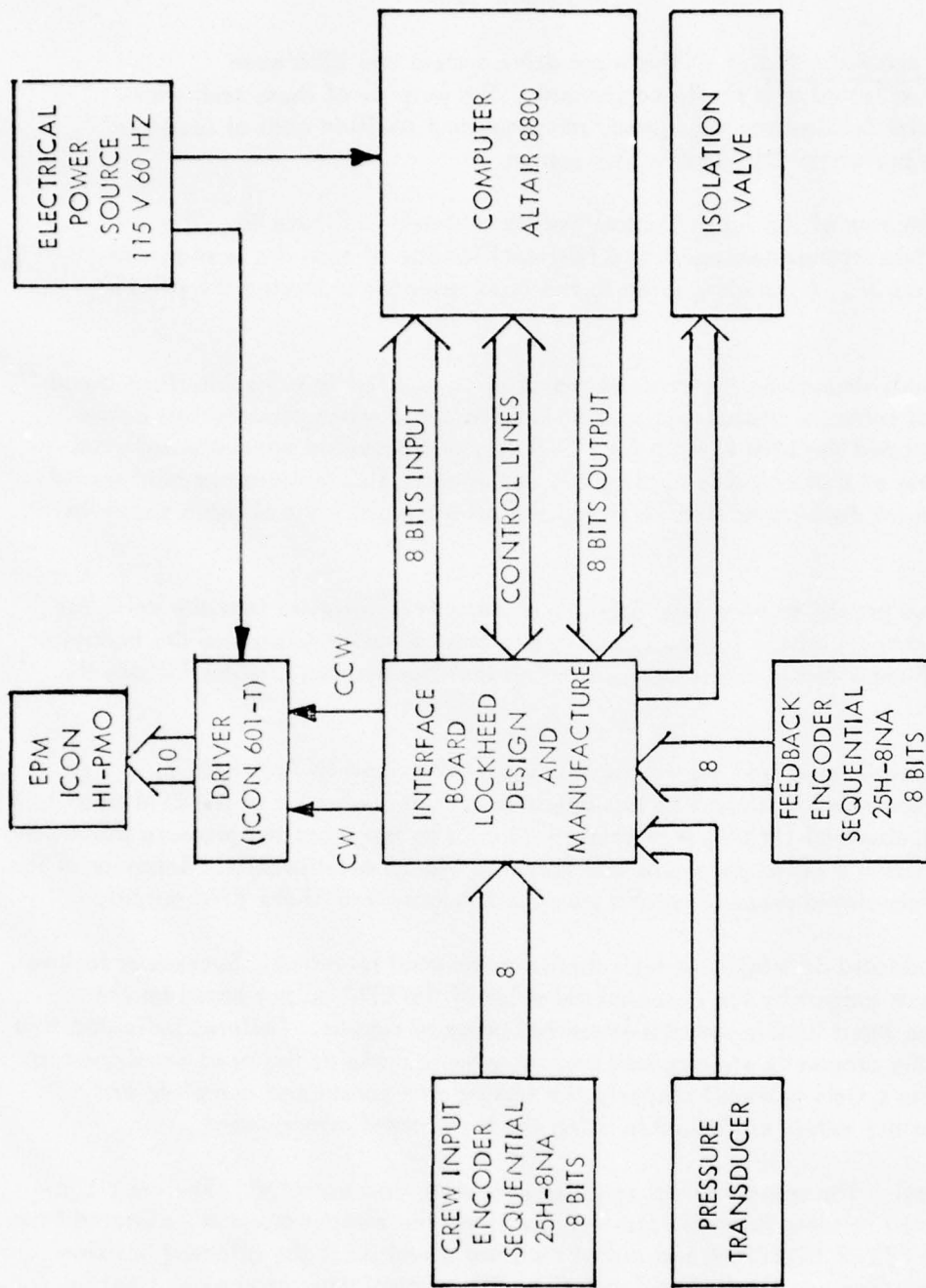

Figure 35 Input Control System

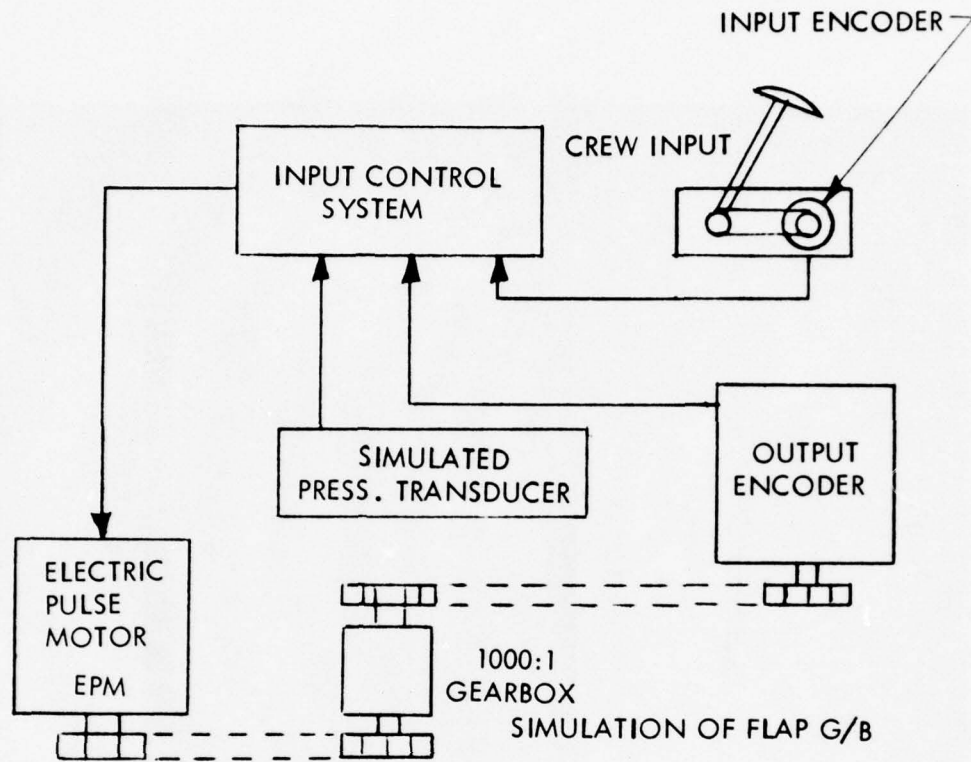

Figure 36 Test Arrangement of Input Control System

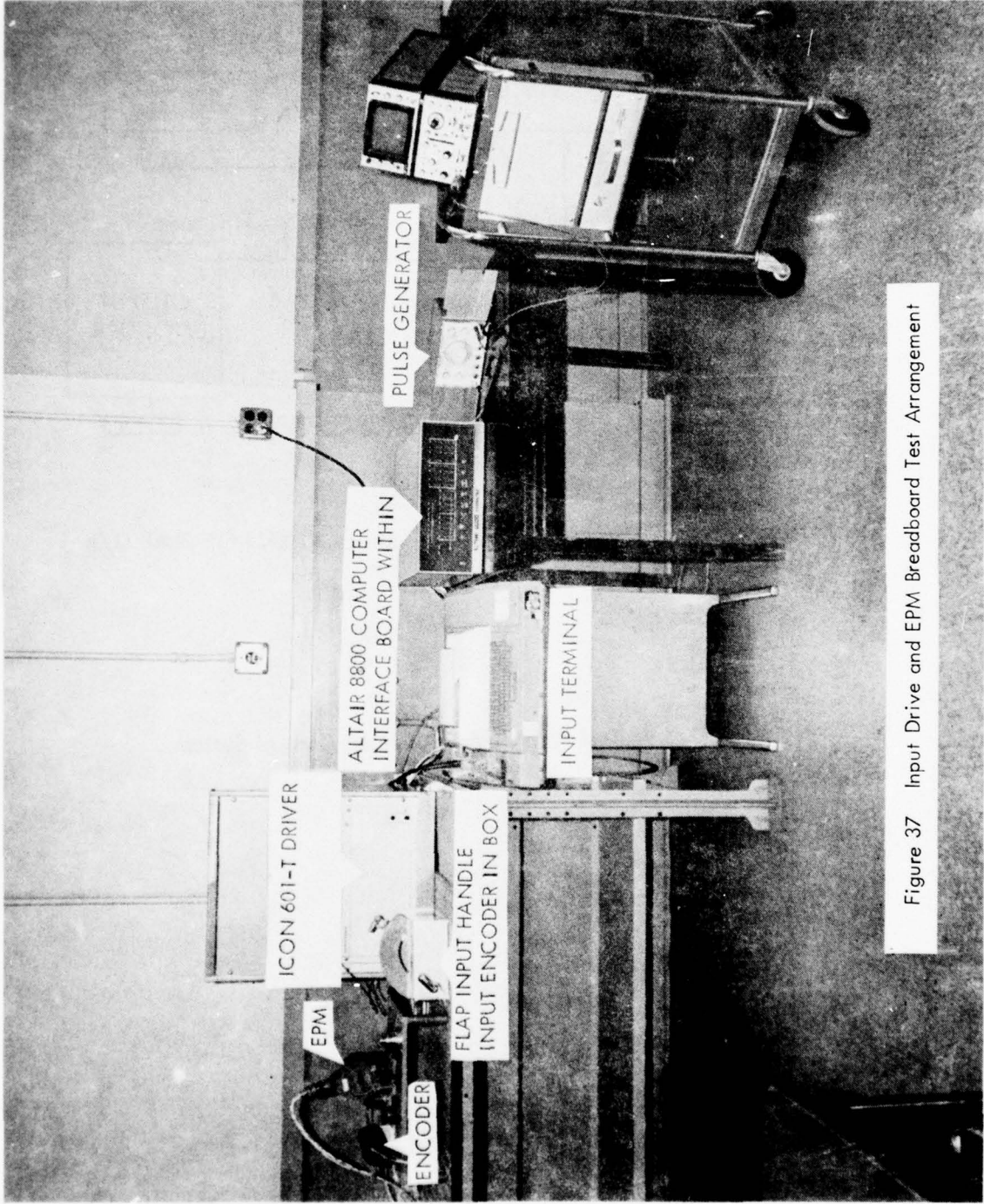

Figure 37 Input Drive and EPM Breadboard Test Arrangement

A variable voltage signal simulating a pressure transducer was delivered to the interface board of the input control system. At a level above 1500 PSI, the stepper motor output speed was 10,000 PPS or 2,000 RPM. As the level was decreased below 1500 PSI, the following occurred as a function of inlet pressure.

- o Stepper motor speed decreased to 1000 PPS at a pressure level less than 1500 PSI.
- o As the pressure level continued to decrease, the stepper motor stopped for pressure less than 1200 PSI.
- o At a pressure level of 1200 PSI and below, a 28-volt signal to operate the system shutoff valve was delivered.
- o On increasing pressure, the shutoff valve signal was removed at 1500 PSI. The stepper motor ramped back to limit speed (10,000 PPS). A variable time delay between system off and back on because of pressure control was demonstrated.

Position Control - The crew input control was moved to any position and the output moved to a corresponding position. The positions of takeoff and approach (737 revolutions of EPM) and landing (921 revolutions of EPM) were demonstrated. Various positions were selected in both extending and retracting flap modes. Reversing while in motion was accomplished.

During the EHPM assembly tests, which are described later, it was suspected that the EPM was not performing up to specification. A "pull-out" test was devised to measure the torque required to stop the EPM, i.e., to pull it out of synchronous speed (it stops). This torque was measured using the apparatus shown in Figure 38. The EPM was first accelerated to the desired speed. The torque was increased by applying by hand a small force to the tail string. The number of turns of string around the wheel was made sufficient so that the control force on the tail string required to achieve the larger force to the spring scale was insignificant compared to the large force. The force was gradually increased while observing the spring scale. The scale reading when the EPM suddenly stopped was recorded as the "pull-out" torque. These tests revealed that the EPM torque when driven by the Icon 601-T driver was considerably below specification. Analysis revealed the need for a different power supply with a current limiting feature which would vary voltage to the EPM as necessary to keep the current high as pulse rate increased. Using a power supply (Lambda Electronics Corp., Model LE 104 FM) which incorporates this feature and with a peak voltage capability of 36 volts the performance of the EPM was significantly improved as shown in Figure 39.

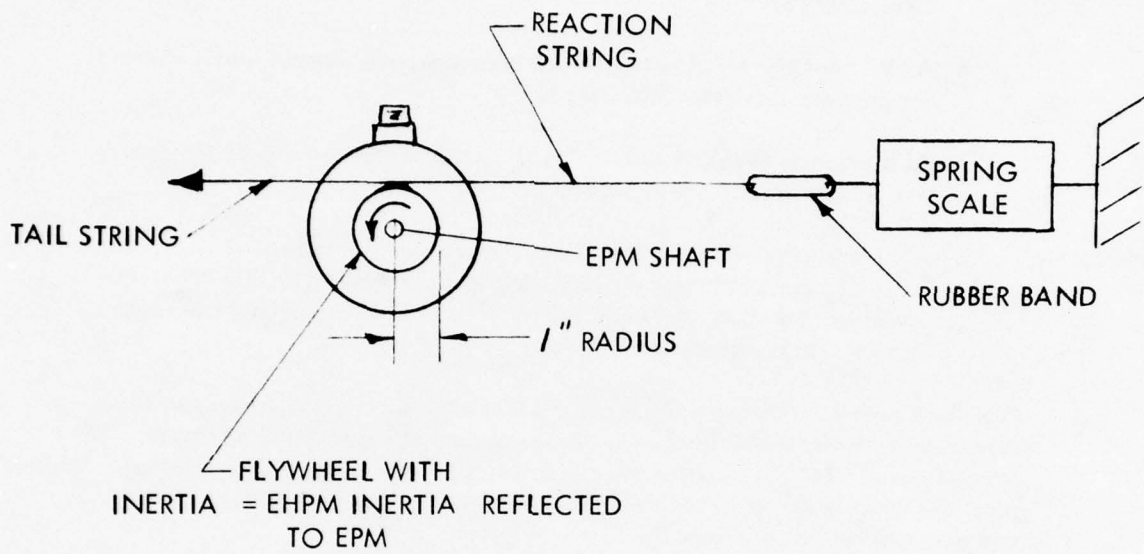

Figure 38 Test Arrangement for Measuring "Pull Out" Torque of EPM

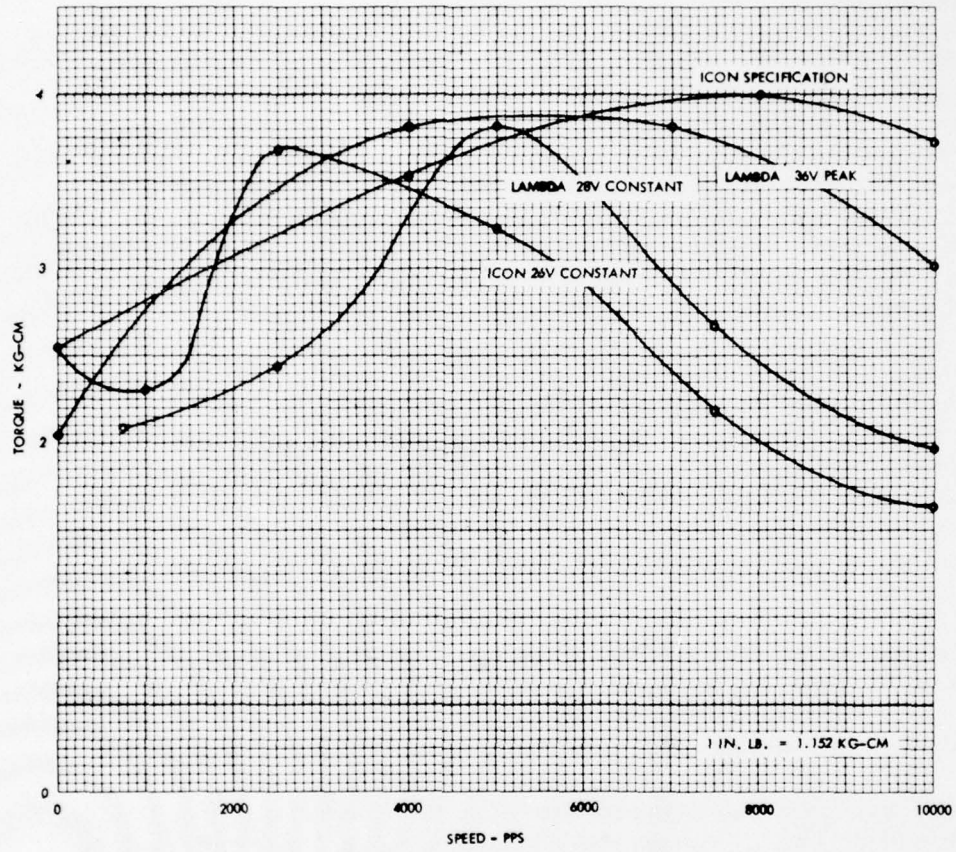

Figure 39 EPM Pull Out Torque

Valve - Hydraulic Motor Tests - These tests consisted of conventional hydraulic motor tests using a conventional port cap, flow tests of the valve (performed at ABEX) and drag torque tests using a DC motor in lieu of the EPM to drive the valve. Two significant problems occurred during these tests. If the valve reaches its maximum travel and bottoms, the nut thread jams and cannot be broken loose by the electric motor. The motor torque plus inertia creates a greater torque for jamming the thread than the motor torque can provide for unjamming the thread. Also, on two occasions the valve spool seized in the sleeve. Chrome plating the spool and opening the clearance between the spool and sleeve appeared to solve this problem. The thread jamming problem is solvable by conventional means, i.e., providing stops that apply a tangential load between the two threaded parts instead of an axial load. Designs to accomplish this were investigated and found to be reasonable. However, no fix was installed in the test unit. In a production unit non-jamming threads will be required.

The drag torque tests revealed an unexpected directional quality. This asymmetry is caused by the pressure load on the EPM end of the valve. As the valve moves away from the EPM the return flow causes higher pressure on the left spool-end than on the right spool-end which is vented through the motor case. The pressure force on the spool is opposite to the flow forces and causes less load to be reflected to the EPM. The phenomena is beneficial, and is a desirable design objective for the other direction. The results of this test are discussed under Durability Tests where the test was repeated.

Drag torque measurements were made using the test arrangement of Figures 40 and 41. Voltage to the DC motor was increased until the desired output speed of the hydraulic motor was reached and then current, speed, and voltage were recorded. The torque output of the DC motor was available from the DC motor calibration tests.

The DC motor calibration tests were performed using the apparatus described previously for EPM "pull-out" tests. Voltage was increased in steps and then torque was increased until the motor slowed to a selected speed. Voltage, speed, torque, and current were recorded. Values were selected to cover the full range of loads and speeds which encompass the specification capability of the EPM.

Flow grinding of the valve provided .0002 to .0004 inch overlap and a neutral cylinder pressure of 250 to 500 psi with 3000 psi supply. The flow gain characteristic is shown in Figure 42. Above .080 inch spool displacement the test was conducted at decreasing supply pressures to maintain a constant flow. The pressure required to produce 27 gpm flow at .010 increments between .080 and .156 was recorded. This data is shown in Figure 43.

EHPM Assembly Tests - The EHPM assembly is shown in Figure 44. Using the test arrangement shown in Figures 45 and 46, the assembly was tested as follows:

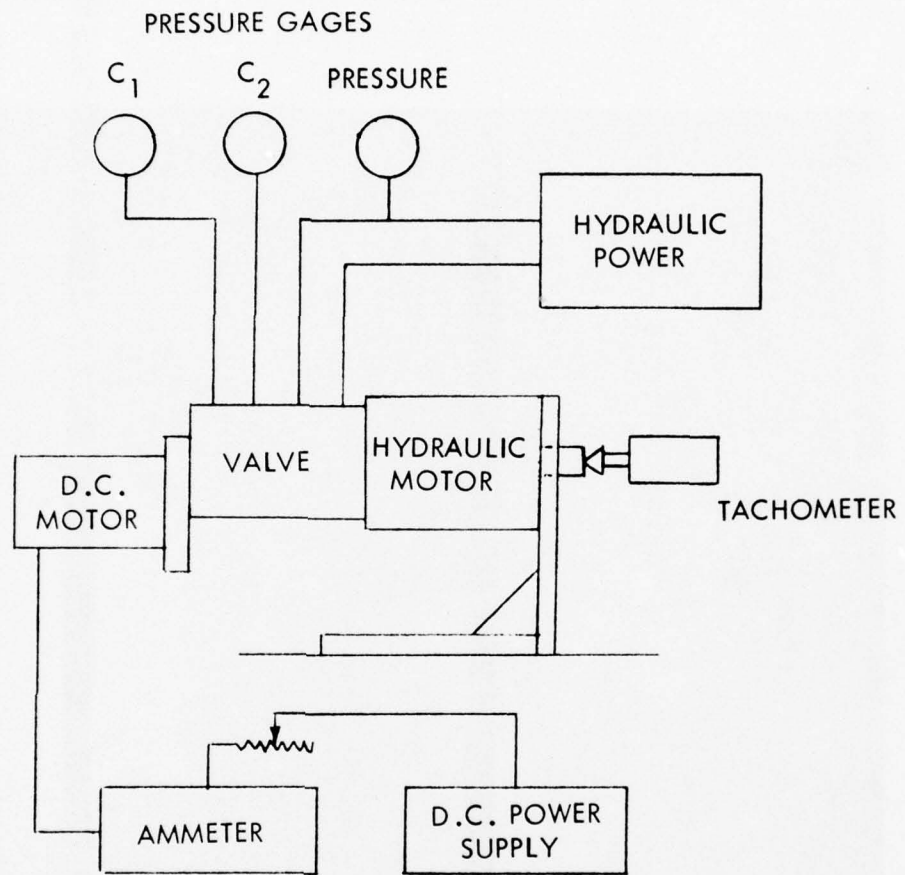

Figure 40 Test Arrangement for Valve Drag Torque Measurements

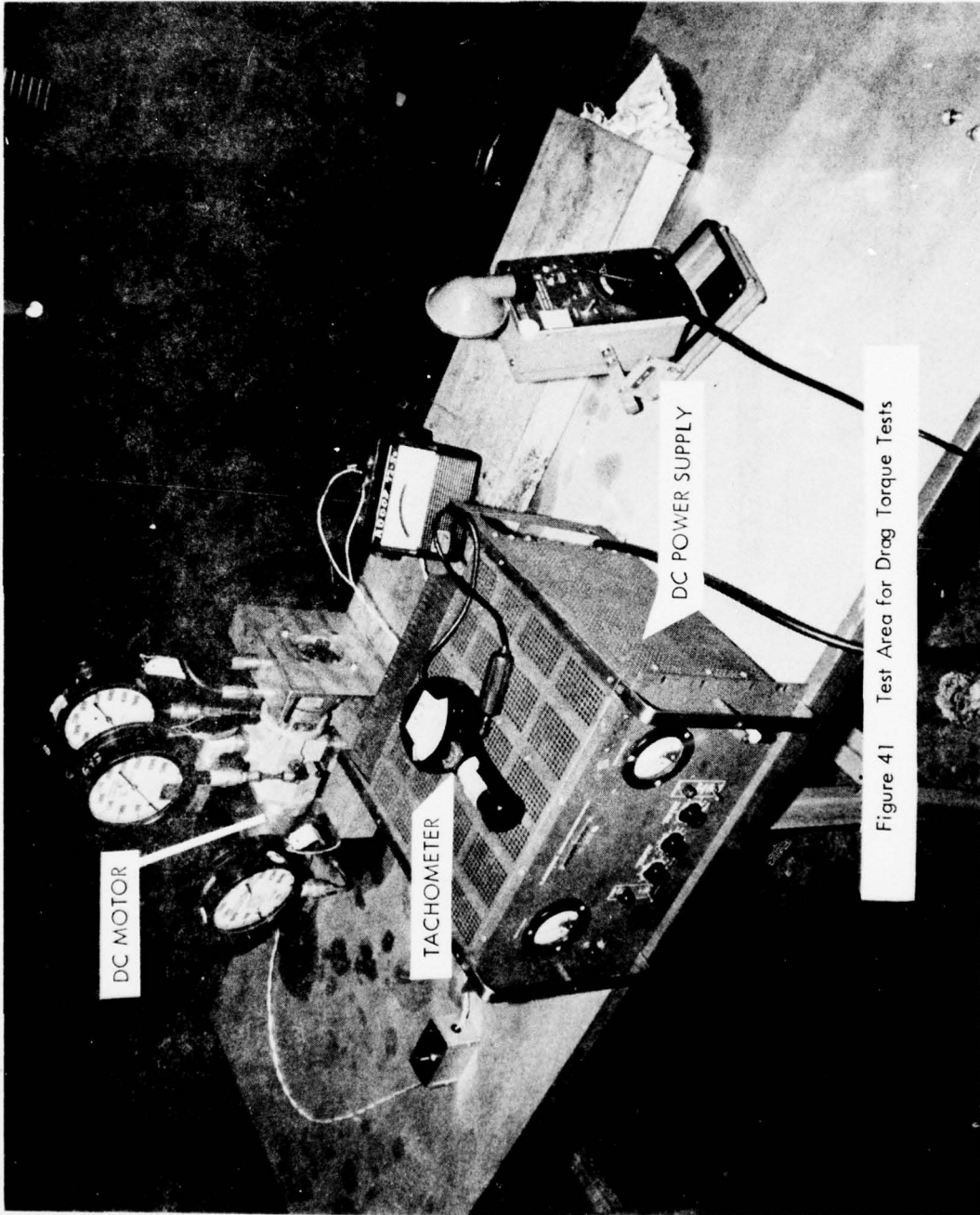

Figure 41 Test Area for Drag Torque Tests

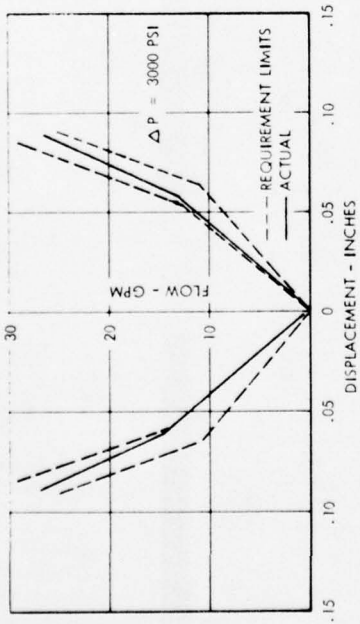
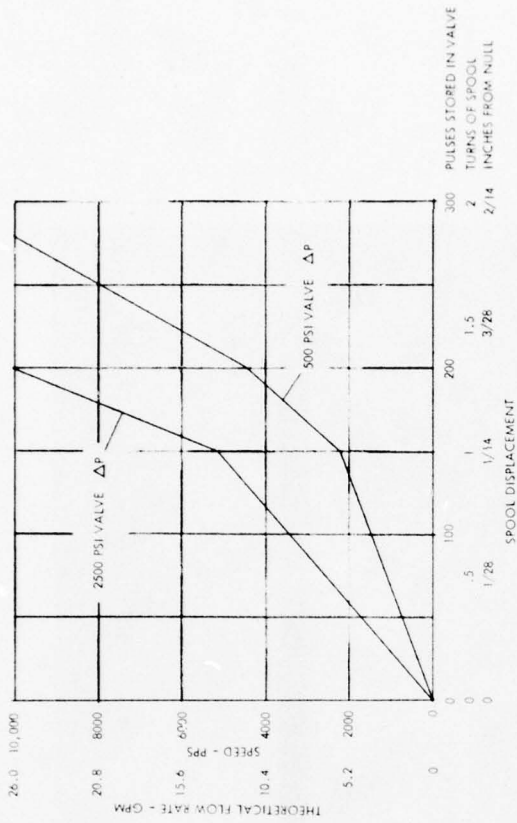

Figure 42 Valve Flow Gain Characteristics

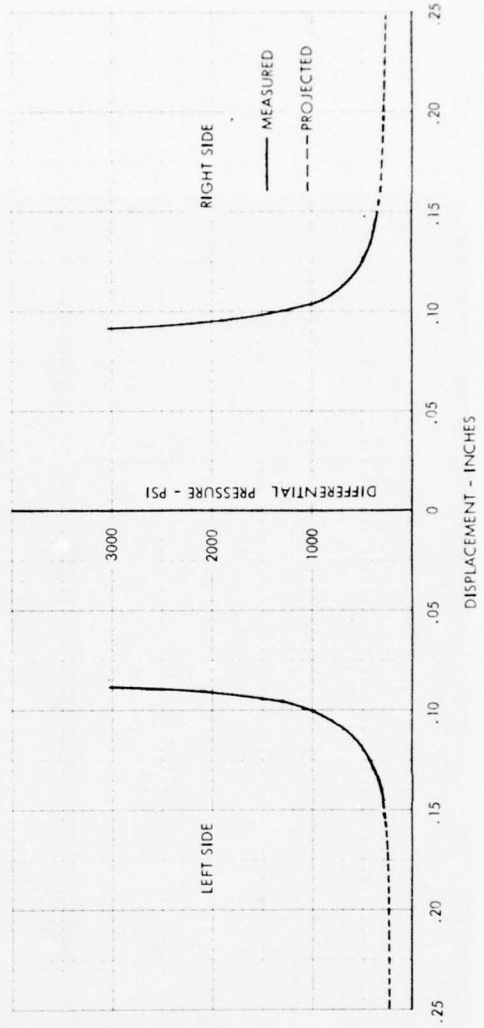

Figure 43 Valve Pressure Drop with 27 GPM

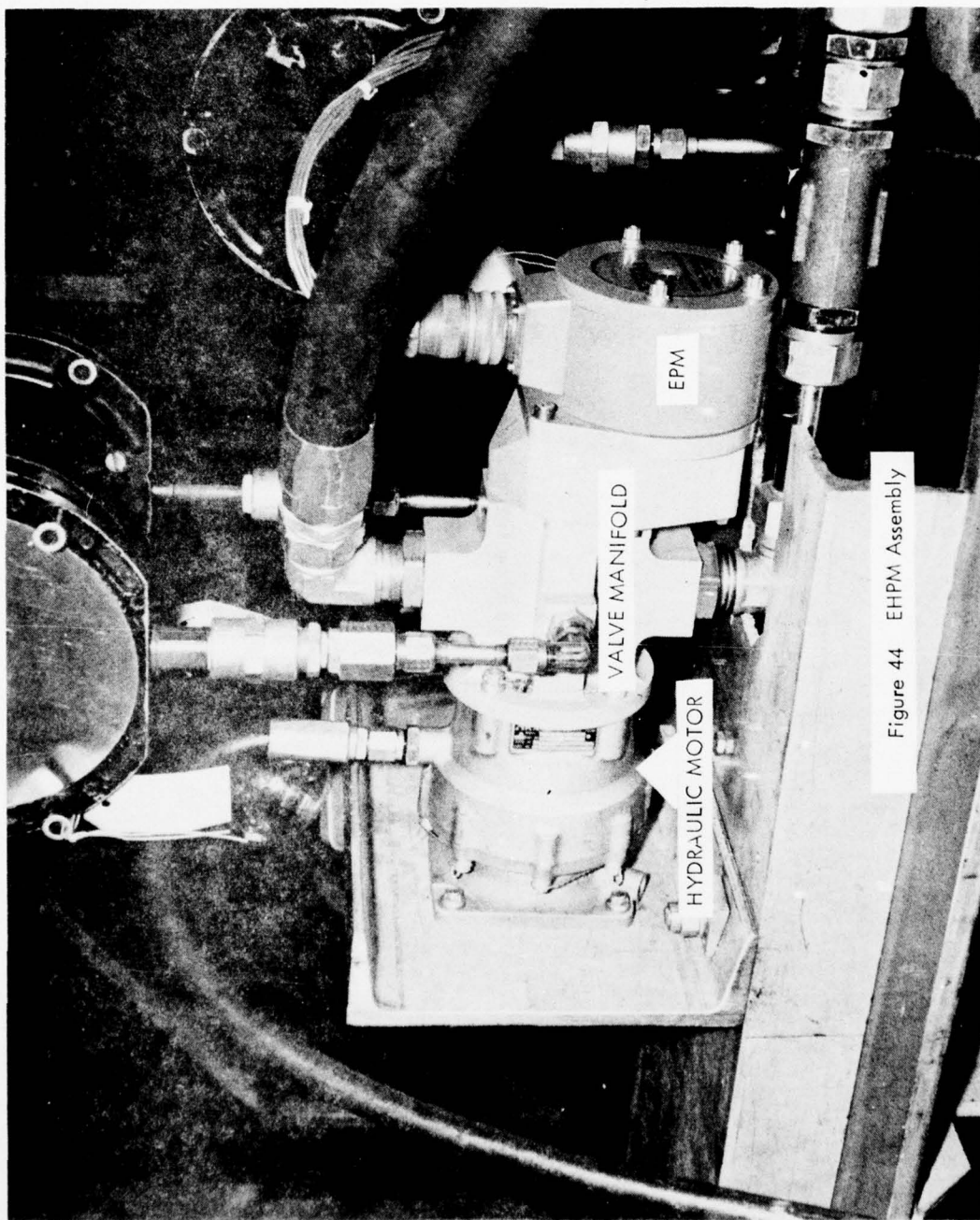

Figure 44 EHPM Assembly

1. FILTER
2. MANUALLY ADJUSTABLE RESTRICTOR
3. CHECK VALVE
4. PRESSURE GAGE 0-5,000 PSI
5. HYDRAULIC LOAD MOTOR
6. EHPM HYDRAULIC MOTOR
7. EHPM VALVE
8. EPM
9. COOLER
10. PRESSURE GAGE 0-600 PSI

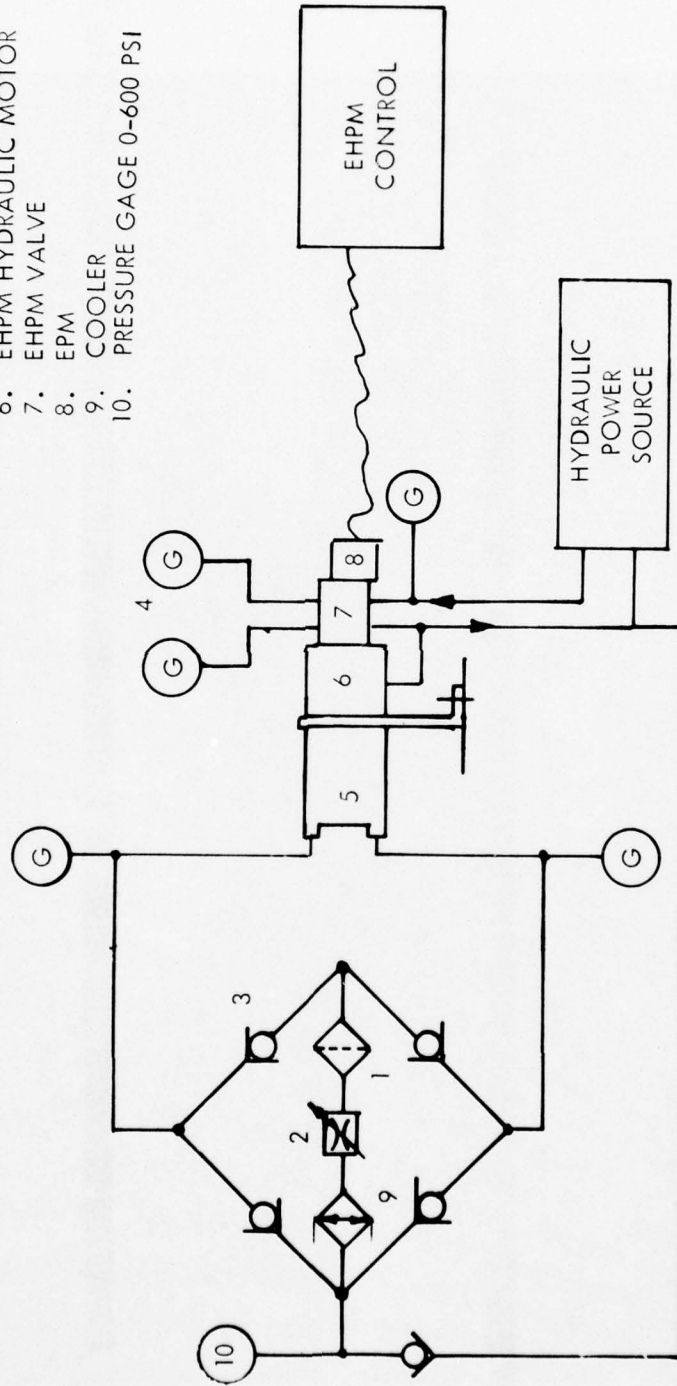

Figure 45 Functional Performance Test Arrangement

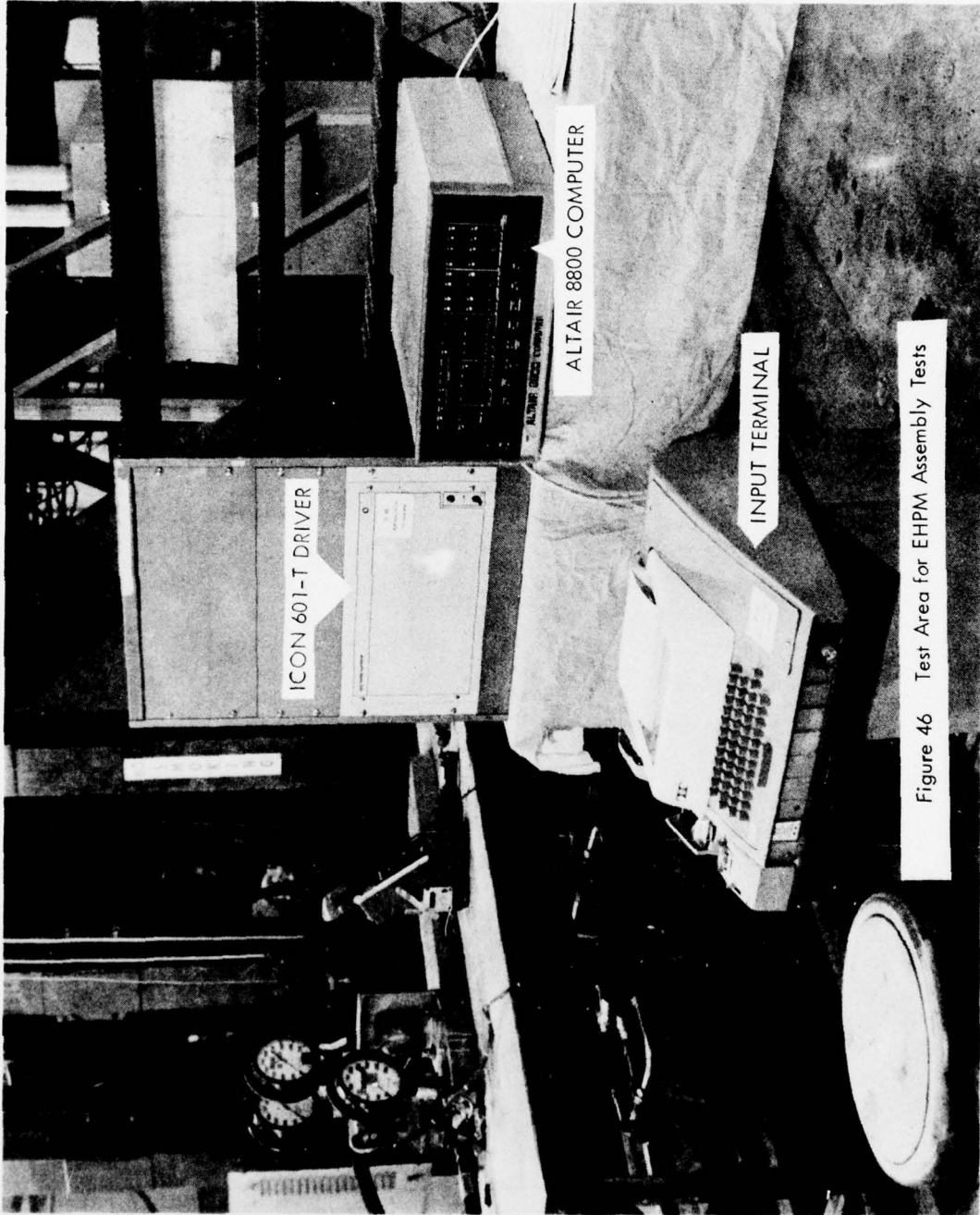

Figure 46 Test Area for EHPM Assembly Tests

No Load - With the load motor (item 5 of Figure 45) and its circuit removed so that the output shaft of the hydraulic motor (item 6) was exposed, attempts were made to accelerate the EHPM to speed. A hand-held tachometer was used on the hydraulic motor output shaft to measure speed.

These tests were attempted initially with an acceleration ramp which consisted of 40 speed values equally divided between 0 and 10,000 pps, i.e., equal steps of 250 pps. The time increment between speed changes was established as a variable to be readily and easily alterable. This arrangement is referred to as a linear ramp. The following results were obtained:

<u>Time Increment, ms</u>	<u>Speed Reached, rpm</u>	<u>Time to Speed, sec</u>
20	2000	0.40 (.02 x 20)
32	2400	0.77 (.032 x 24)
48	2500	1.20 (.048 x 25)
96	3000	2.88 (.096 x 30)
192	3500	6.72 (.192 x 35)

The ramp was revised to provide 83 values so that the speed differences between adjacent values in the acceleration table could be smaller as the speed increased, i.e., a nonlinear ramp (similar to an exponential ramp).

The ramp used is illustrated in Figure 47 and is compared with two exponential curves and a sine wave which approximate the selected ramp at the upper end. The same ramp was used for deceleration.

In accelerating to a limit speed the control established an initial pulse frequency (R) of 750 pps, delayed an increment of time, Δt , established $R = 1000$ pps, delayed Δt , established $R = 1200$, delayed Δt , etc. until the limit speed was reached. The limit speed was a settable value in the program. The values 750, 1000, 1200 -- 10,000 were in effect stored in memory as a table. To accelerate, the table was ripped through in increasing value and to decelerate was ripped through in decreasing value. The delay increment, Δt , was also a settable value in the program. After being set it was the same for every speed value. It is pointed out that for limit speeds which were less than 10,000 pps, the limit speed was not approached gradually. For example, if the limit speed were 6000 pps, 30 time increments were used to reach limit speed along the curve of Figure 47 and then the frequency remained constant at 6000 pps.

With the revised ramp the unit would still not reach a 4000 rpm limit speed. Limit speed, a setting in the program, was reduced in steps until the unit could achieve limit speed. After achieving this speed it would sometimes stop, indicating that acceleration was not the problem and that EPM torque was marginal. A test was then devised to measure EPM "pull-out" torque. This test was discussed earlier under the input system. Low EPM torque was found to be the problem. A revision to the DC power supply was made to correct the problem. With the revised power supply (Lambda)

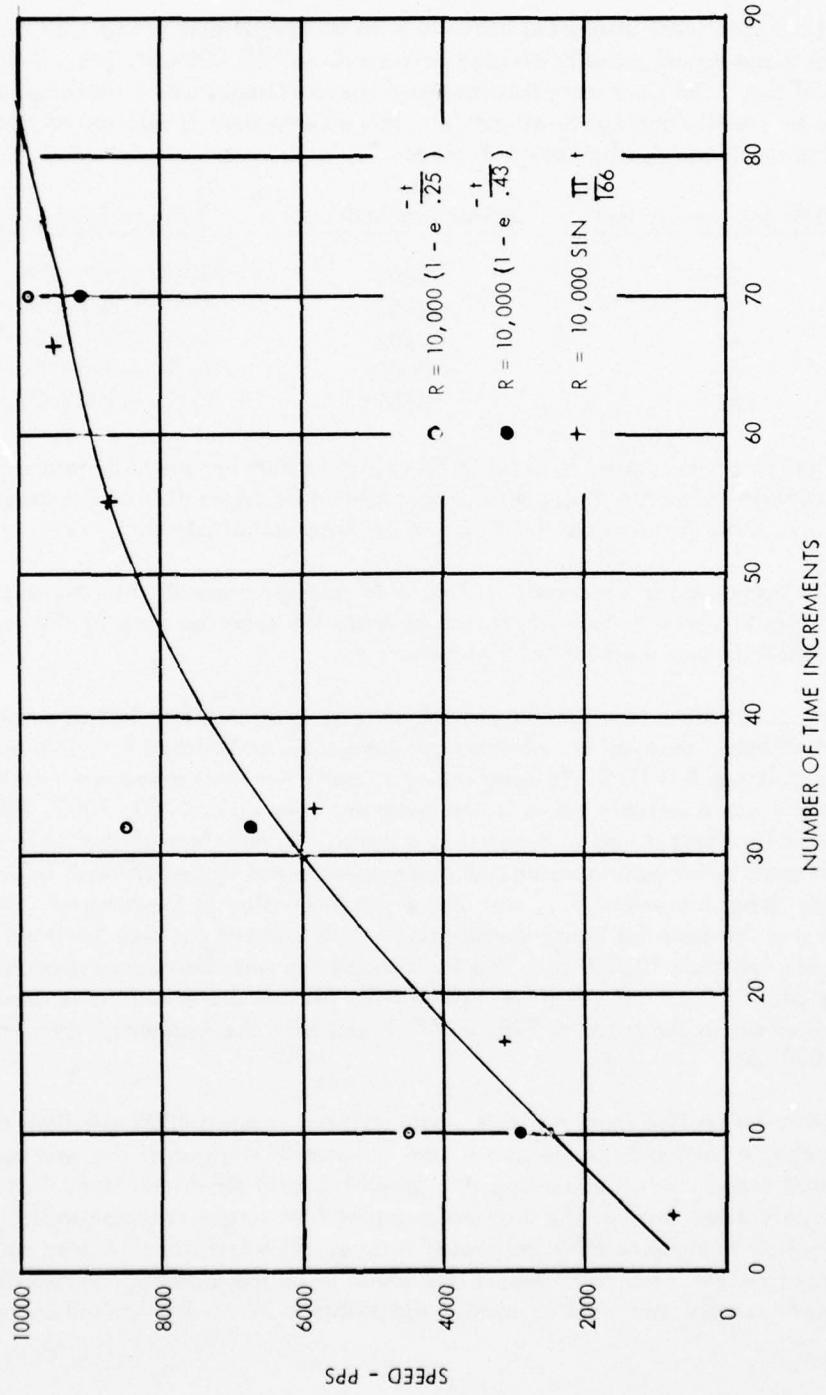

Figure 47 Non-Linear Acceleration Ramp Compared with Formalized Curves

4000 rpm could be achieved with 30 volts in the CW direction and 3200 rpm with 35 volts in the CCW direction. It would reach these speeds with a time increment as low as .007 sec (time to reach 4000 rpm = 83 increments x .007 sec. = .58 sec.).

Load - With the load motor installed (as in Figure 45) the EHPM was accelerated to a selected speed and the load was applied using a manually operated needle valve (item 2 of Figure 45). Then without changing the position of the load valve the EHPM was stopped and repeatedly started and stopped in both directions. A load of 2350 psi differential between C1 and C2 was the maximum used. Data were recorded from gages for some of these tests and with a brush recorder for others. Deceleration ramps were not used for these tests.

The unit performed slightly better under load, achieving 4000 rpm in the CW direction and 3840 rpm in the CCW direction with a time increment to .004 sec. consistently and to .003 sec. not consistently.

Leakage Tests - With a fluid temperature of 100°F, C₁ and C₂ ports open and 3000 psi applied to the pressure port and with leakage from C₁ and C₂ visually equalized by manually moving the hydraulic motor output shaft the combined leakage from C₁ and C₂ was 890 cc/min.

With C₁ and C₂ closed and their pressures equalized by manually moving the hydraulic motor output shaft, the combined leakage from the return and motor case was 900 cc/min. (0.24 gals/min).

Iron Bird Tests

The EHPM control circuit illustrated in Figure 48, controlled by the digital computer, was used to operate the C-5 Iron Bird flap system, Figures 49 through 55, with no load, intermediate load, and maximum load. Initially the return from the EHPM was routed into the normal system return which is exposed to boost pump pressure that is nominally 100 psi. The unit would not operate satisfactorily due to return pressure loads on the nut bearings which must be rotated by the EPM. When the return was routed directly to the reservoir the unit could achieve 100% speed (4000 RPM) in the extend mode and 92% speed in the retract mode. The unit started and stopped smoothly at all positions of the flap and with the various loads. The acceleration and deceleration ramps could be readily altered and the effect on system performance promptly evaluated from the data recordings. The speed reduction feature, which causes speed to reduce when pressure falls below set point (1500 psi) and to stop and apply brakes when below brake set point (1200 psi) wait 2 seconds and then restart, worked well, except that operation at the 1500 psi set point caused a pressure (± 125 psi) and flow (± 1.5 gpm) pulsation of approximately 1 cps while the average flow and speed was decreased to maintain the 1500 psi inlet pressure. The motion of the flap mechanism was not severe and was controlled by the program. The EHPM responded as programmed by stepping up in speed and then down in speed to maintain the pressure setting. Although this mode of operation is not normal it does occur when system flow demand is greater than system flow capacity. It is believed that the pulsation can be removed by programming, but time did not permit trial of the program changes.

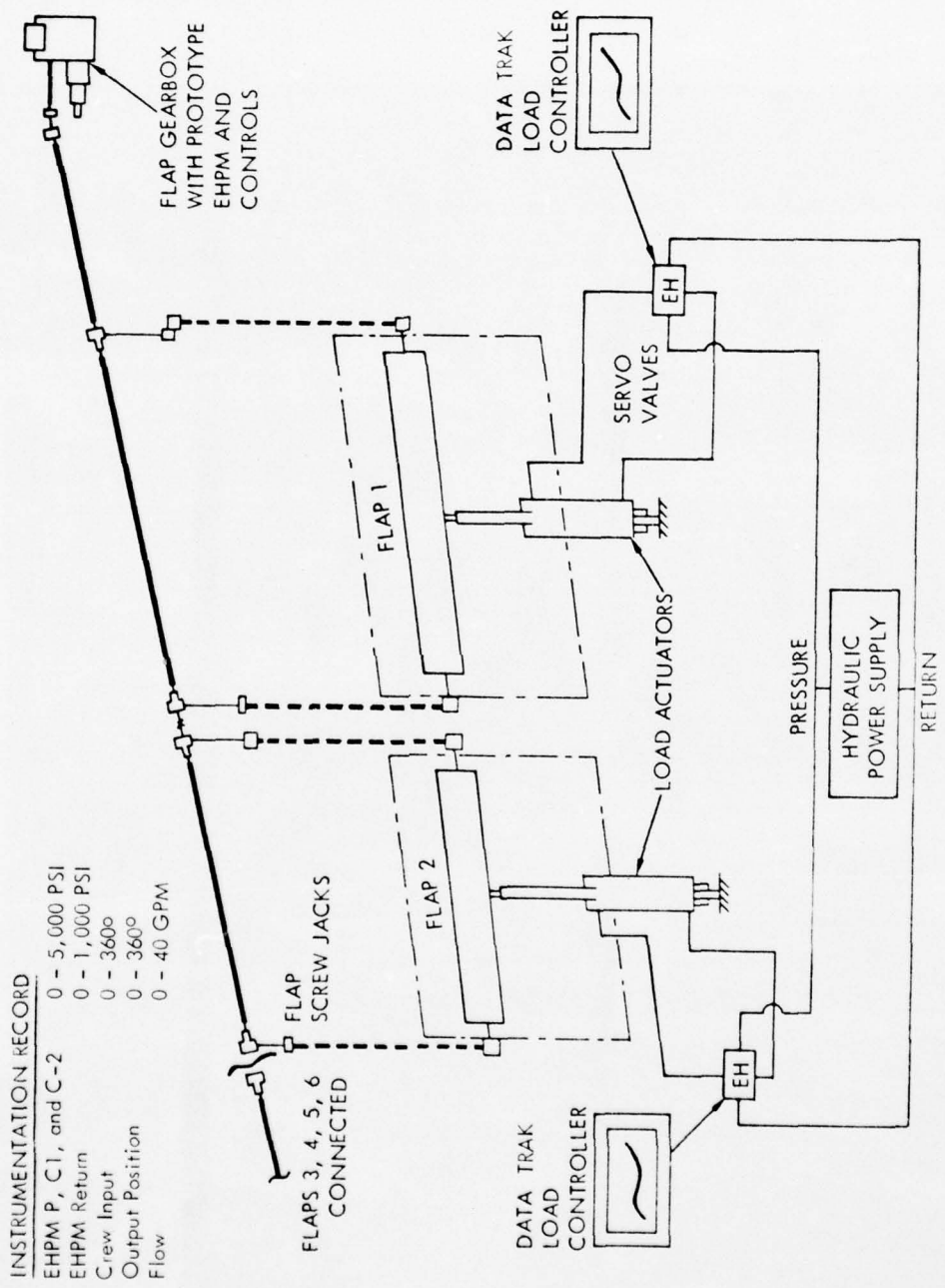

INSTRUMENTATION RECORD

EHPM P, C1, and C-2	0 - 5,000 PSI
EHPM Return	0 - 1,000 PSI
Crew Input	0 - 360°
Output Position	0 - 360°
Flow	0 - 40 GPM

FLAPS 3, 4, 5, 6
CONNECTED

FLAP
SCREW JACKS

Figure 49 Iron Bird Test Arrangement - Flap System



Figure 50 C-5 Iron Bird Flap and Loading Mechanism

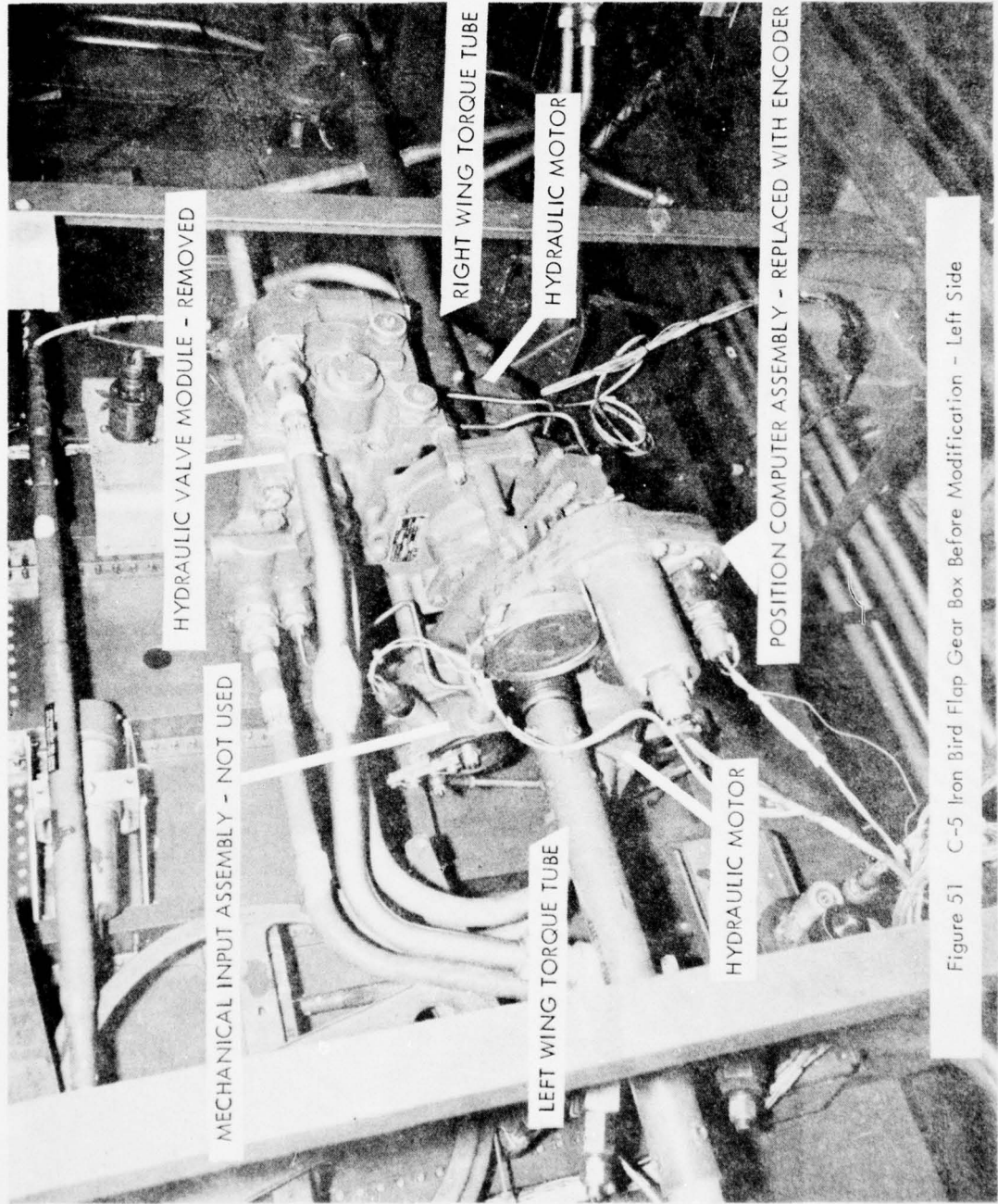

Figure 51 C-5 Iron Bird Flap Gear Box Before Modification - Left Side

AD-A042 377

LOCKHEED-GEORGIA CO MARIETTA
INVESTIGATION OF ELECTRO-HYDRAULIC PULSE MOTORS FOR AIRCRAFT UT--ETC(U)
MAY 77 E W RUMRILL, F D LEWIS
F33615-75-C-2005

F/G 1/3

UNCLASSIFIED

LG77ER0099

AFAPL-TR-77-14

NL

2 OF 2
ADA
042377



END
DATE
FILMED
8-77

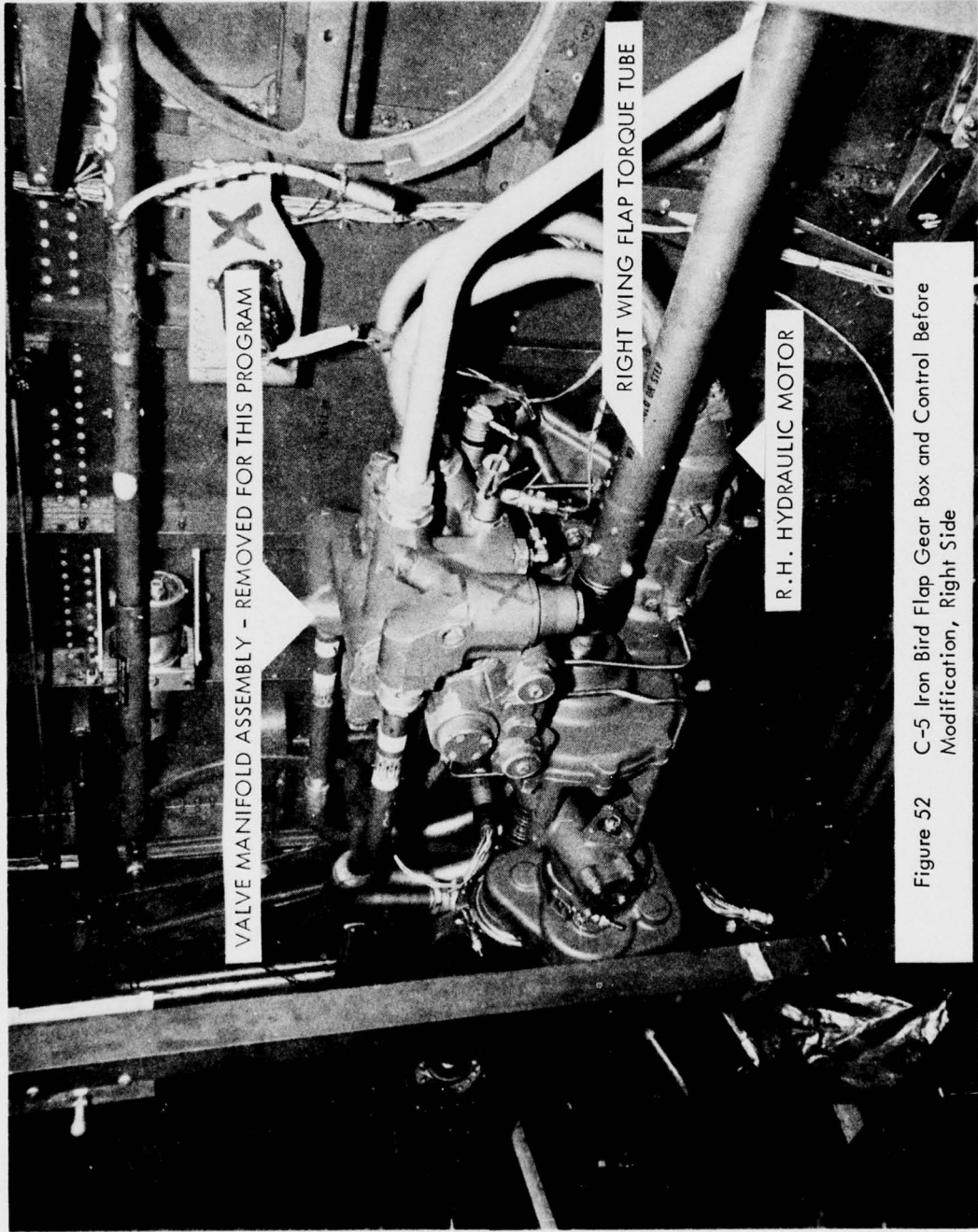

Figure 52 C-5 Iron Bird Flap Gear Box and Control Before Modification, Right Side

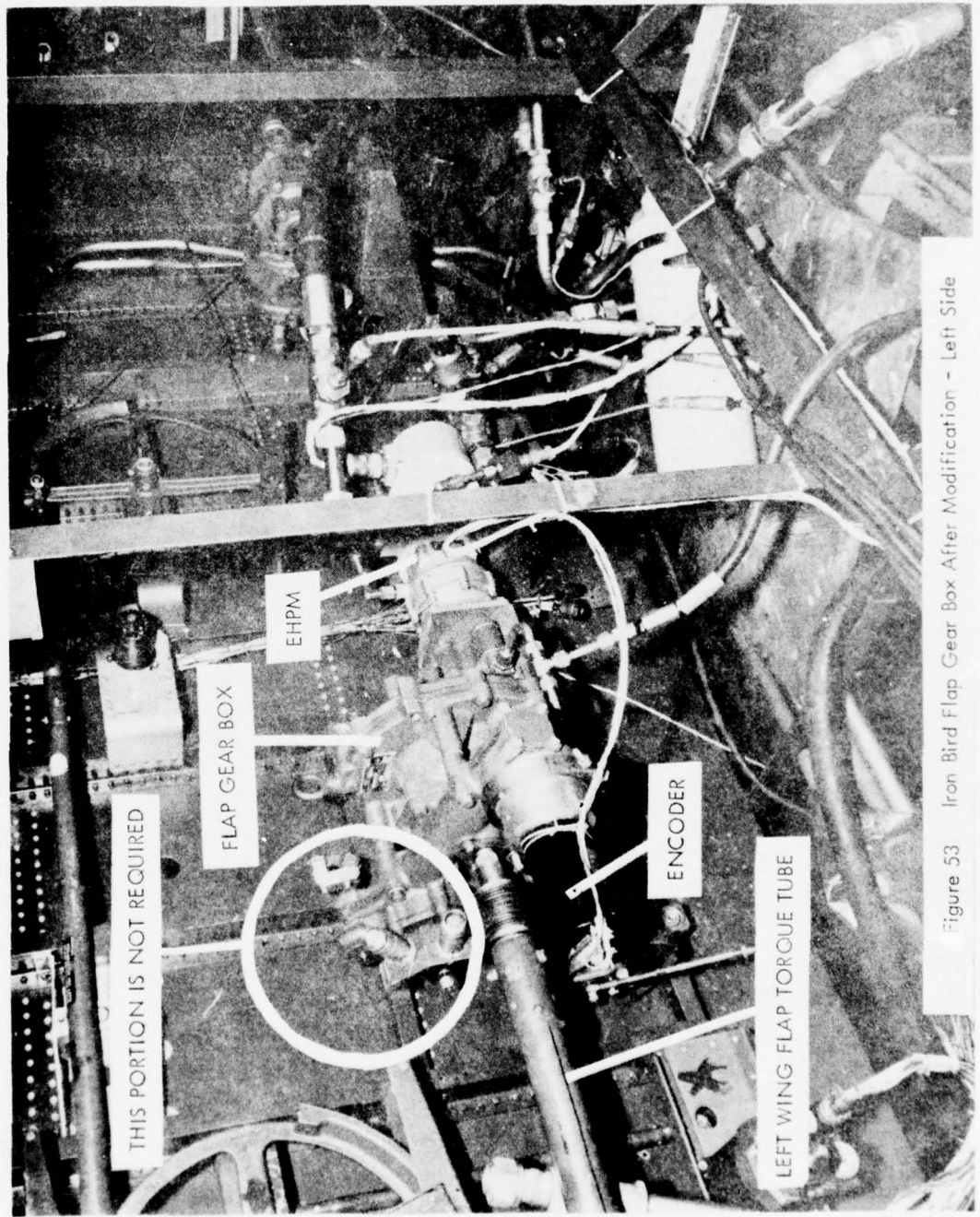

Figure 53 Iron Bird Flap Gear Box After Modification - Left Side

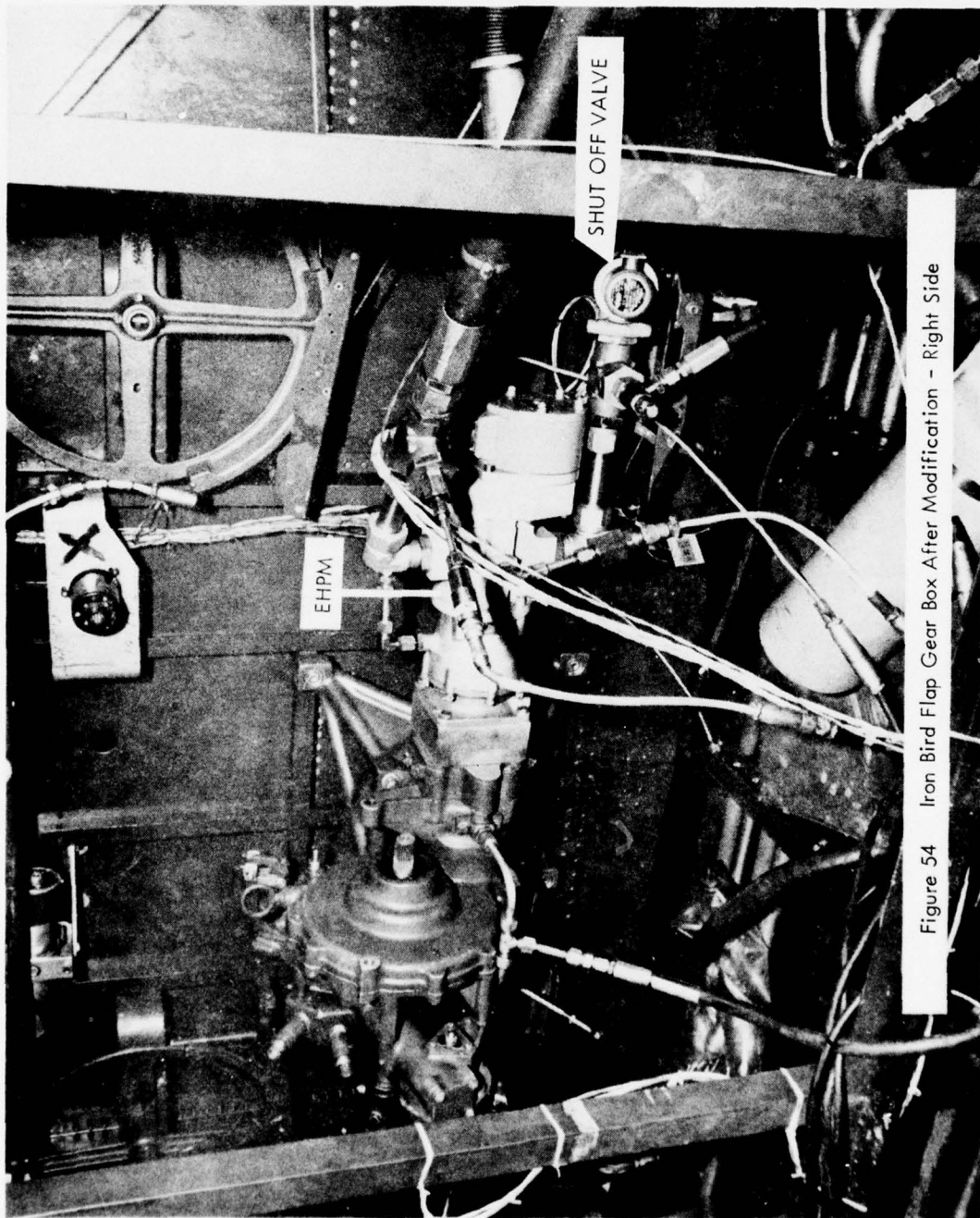

Figure 54 Iron Bird Flap Gear Box After Modification - Right Side

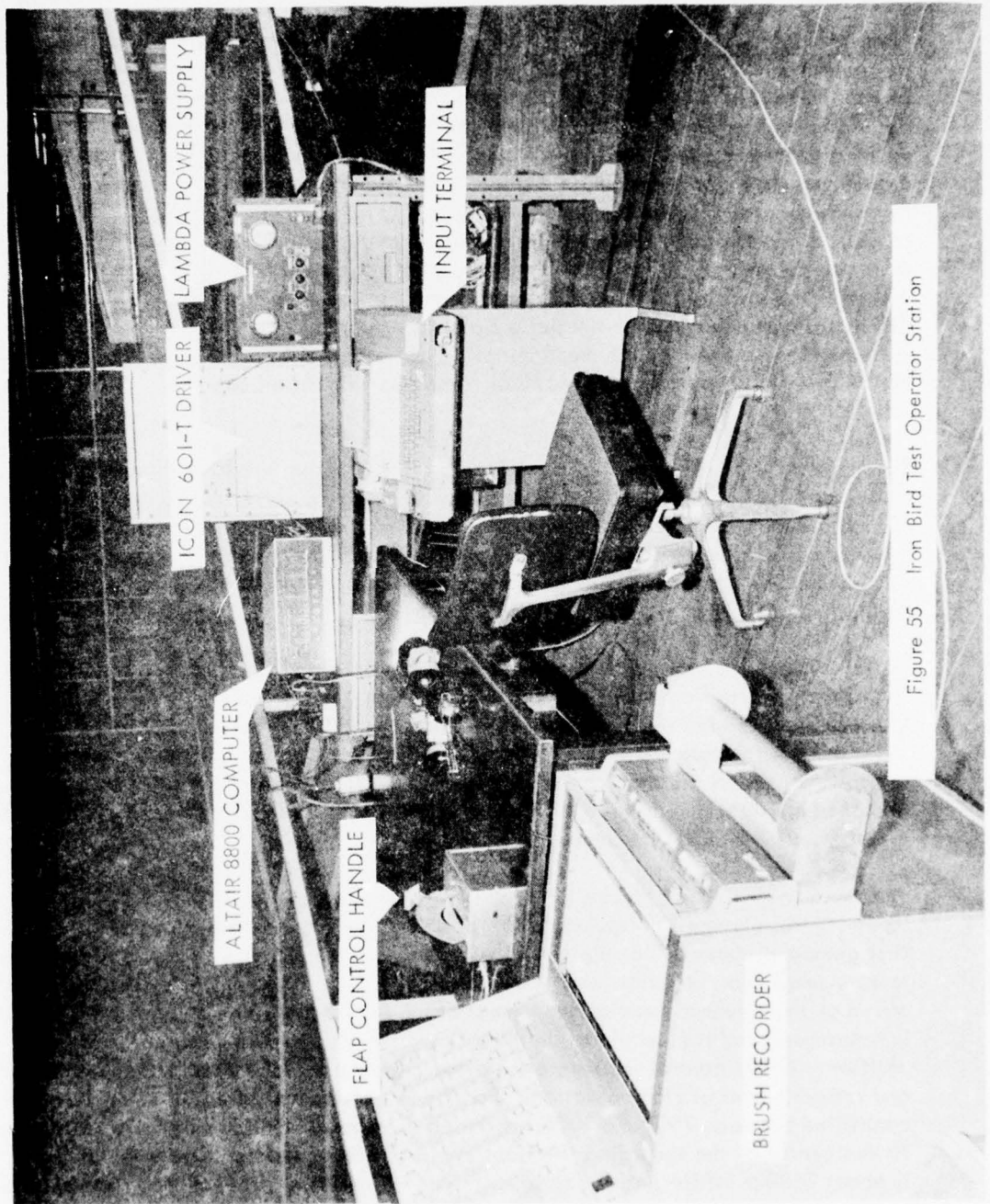

Figure 55 Iron Bird Test Operator Station

The test results are shown in a series of brush recordings to show the dynamic response of hydraulic pressures, flap input control, and output position. Flow rate can be used as a measure of system speed using the directly proportional speed/flow relationship of the fixed displacement EHPM motor. A flow of 27 gpm is equivalent to 4000 rpm of the EHPM. The flow rate curve also identifies the acceleration/deceleration characteristics.

Ground Cart Operating Runs with No Deceleration Program - The first test runs on the Iron Bird were accomplished with the hydraulic power from a hydraulic ground cart. For these runs, the software program did not provide a ramped deceleration. When the input and output encoders matched, the EPM was stopped without decreasing speed with a ramp. The flap system was actuated a number of cycles and data was recorded on a brush recorder. Performance is shown in Figure 56. Although the system was programmed for only 50% speed the pressure transients are noticeable, particularly on deceleration. Stopping was very positive causing a hard transient throughout the mechanical flap drive system. The deceleration characteristic shown on the flow trace is caused by the EHPM valve feedback after the pulse motor has stopped. This rate of deceleration is perhaps too severe for the mechanical drive system. When the decel program was added the pressure and mechanical transients were eliminated.

Engine Pump Operating Runs with a Deceleration Program - With hydraulic power delivered from the Iron Bird engine pumps and using a software program which included a decel ramp the flap system was operated through several extend and retract cycles and data was recorded. Cycles were accomplished with no load, with partial, and with maximum loads. The system was stopped and started at various positions of the load.

In the initial tests, maximum speed could not be obtained when operating with the Iron Bird hydraulic power system. Investigation determined that a high return pressure and a design characteristic of the prototype EHPM generated high thrust loads on the translator nut bearings and higher torque demands on the EPM. The return flow was routed directly to the reservoir reducing the return pressure. With this change 100% speed (4000 RPM of the EHPM) when extending the flaps and 92% speed when retracting the flaps was achieved.

The brush recordings of Figure 57 show the excellent response of the system to input control changes. Mechanical functioning was very smooth and quiet. At first glance it appears that the control is erratic, however, the system is responding to very small short duration input control changes. In the first few cycles the flaps arrive at the selected position before obtaining full speed. The acceleration ramp is interrupted and the deceleration ramp slows the unit to a stop at the selected position. Other control inputs are followed by smooth output control for the extend and retract modes of flap operation. For the selected recordings, the flap travel was controlled between 75% and 100% where the flap loads change from zero to maximum. At the center of the recording the flaps are 100% extended and the motor pressure is about 2600 psi differential, close to the design point at rated speed. On the right

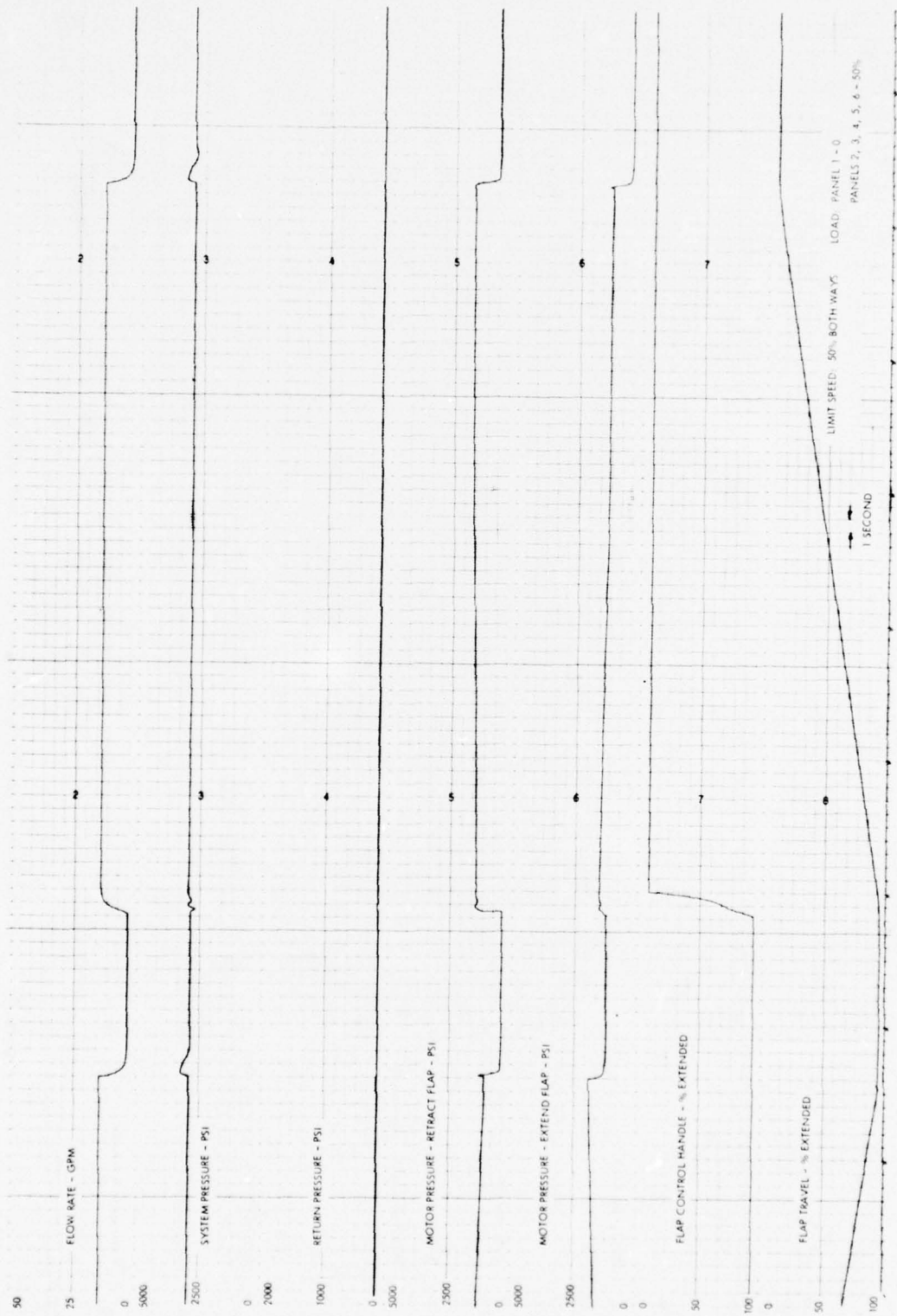

Figure 56 EHPM Performance on C-5 Iron Bird with Hydraulic Ground Cart with no Decel Program

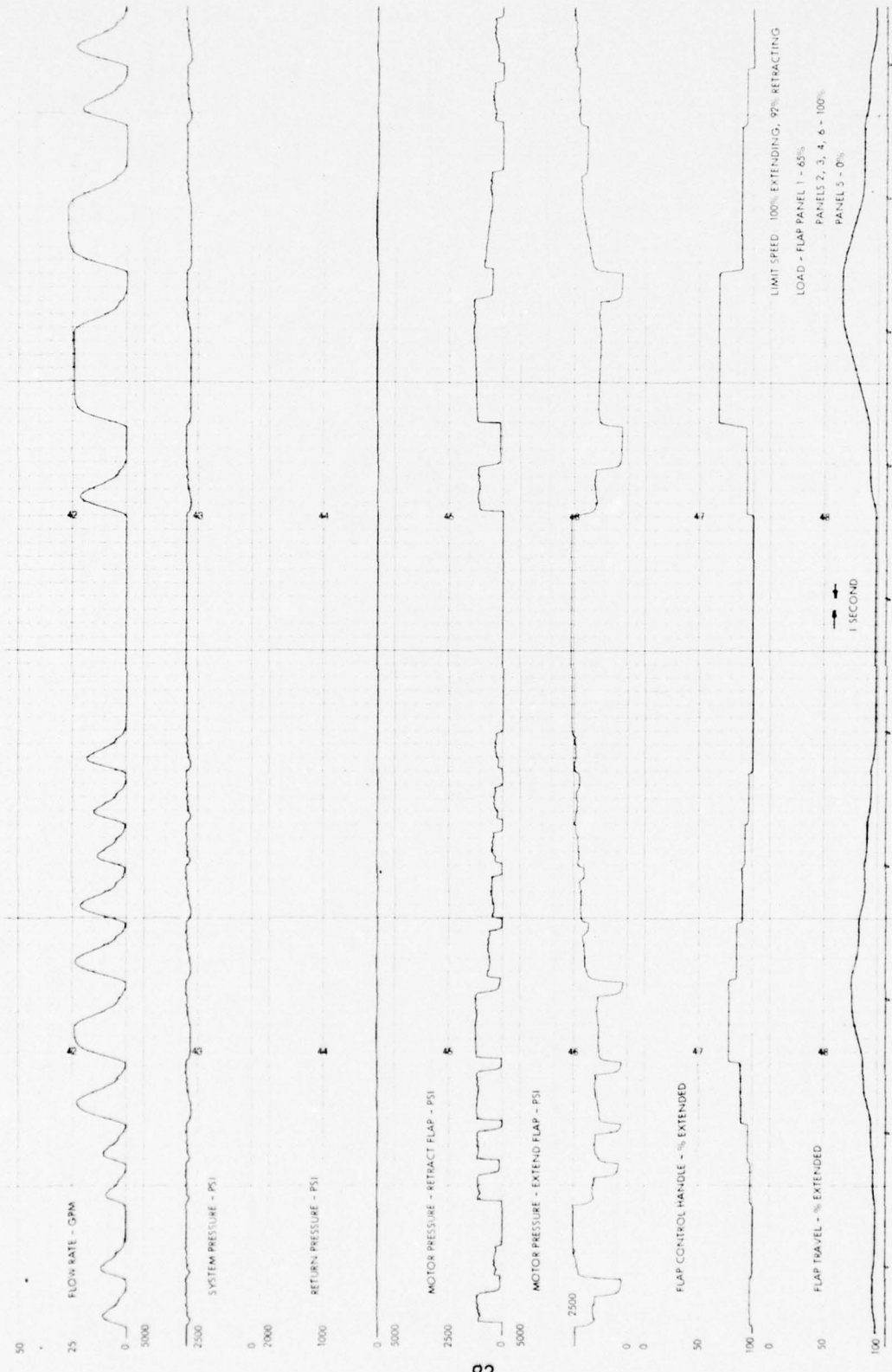

Figure 57 EHPM Start-Stop Performance on C-5 Iron Bird with Maximum Loading

side of the recording a 92% retract speed (25 gpm) and a 100% extend speed (27 gpm) was obtained. It should be noted that the programmed acceleration/deceleration ramps have eliminated pressure surges in the hydraulic system and EHPM motor and that the pressure changes occur smoothly as a result of system loads. The EHPM translates smoothly from running to stall, and the stall pressures are proportional to load. At approximately 75% flap travel the load is zero and null pressures are below 500 psi. At 100% flap travel the differential pressure is 2600 psi holding maximum load. The programmed EHPM flap drive system started and stopped smoothly for all loads and modes of operation of the input control handle, including reversal while in motion, before and after reaching limit speed and when taking a single encoder step (about 1250 pulses). A normal cycle flap operation is shown in Figure 58. The flap drive system was loaded by the Iron Bird flap actuation load system. The extend time at 100% speed was 28 seconds the retract time at 92% speed was 30 seconds.

Some mechanical problems were encountered during this phase of the testing. The problems generally resulted in jamming of the nut/screw translator drive assembly, a known deficiency of the prototype EHPM design. The jamming was caused by either (1) a malfunctioning of a torque limiter in flap panel #5 actuation system or (2) running into the stops during program trials and changes. Minor disassembly or torqueing the EPM input shaft corrected the jamming and testing continued. This problem can be corrected by non-jamming stops in later EHPM's.

Response to Inadequate Hydraulic Supply - Two tests were conducted to evaluate the behavior of the system when hydraulic supply was not adequate causing system pressure to drop. In the first of these tests, system supply was adjusted by pump speed so that system capacity was only slightly more than adequate to operate the EHPM. A fixed by-pass flow of 9 gpm (limited by a flow regulator) was suddenly applied while the EHPM was operating. The by-pass load simulated the operation of some other load in the system such that the total flow required exceeded the capacity of the system. In the second test the engine pump was operated at decreasing speed so as to decrease its capacity. The EHPM was operated while capacity was decreasing to record operation at various levels of inadequate flow rate.

When operation of some other device in the system causes system capacity to be exceeded, system pressure will drop below normal and can under some conditions drop below flap brake release pressure. This will cause the brake to cycle on and off or drag. Either case is unsatisfactory and the control system must prevent this mode of operation. Therefore, the program reduces the EHPM speed when system pressure is below 1500 psi and causes it to stop when the pressure is below 1200 psi. The brake is applied by shutting off pressure to the system via a shut-off isolation valve when system pressure is below 1200 psi. To prevent uncontrolled cycling a 2-second delay is programmed between the shut down and restart due to pressure rising above 1200 psi. Performance for this mode of operation is typified by the recorded data for one run shown in Figure 59.

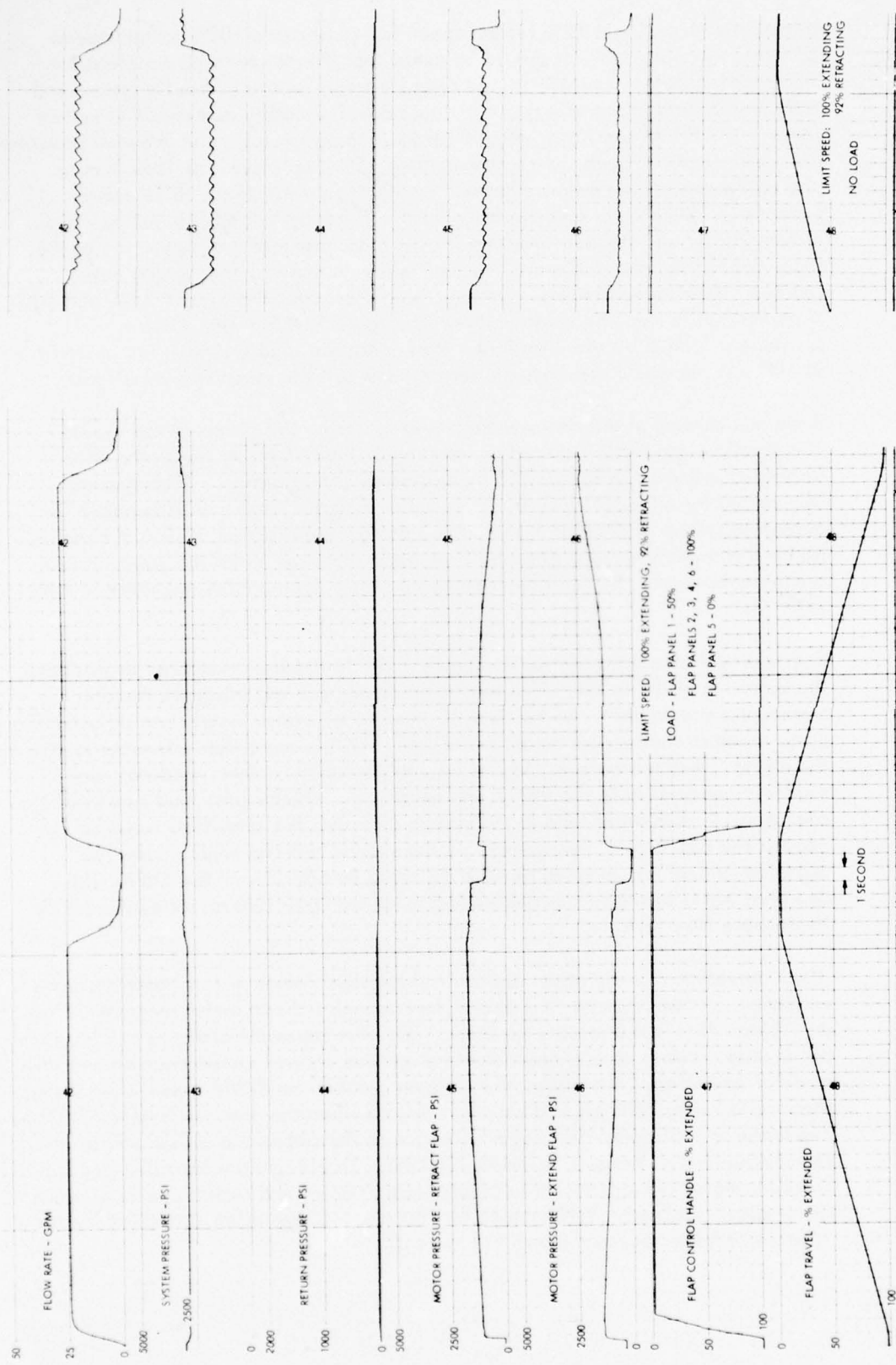

Figure 58 EHPM Full Cycle Performance on C-5 Iron Bird with Partial Loading

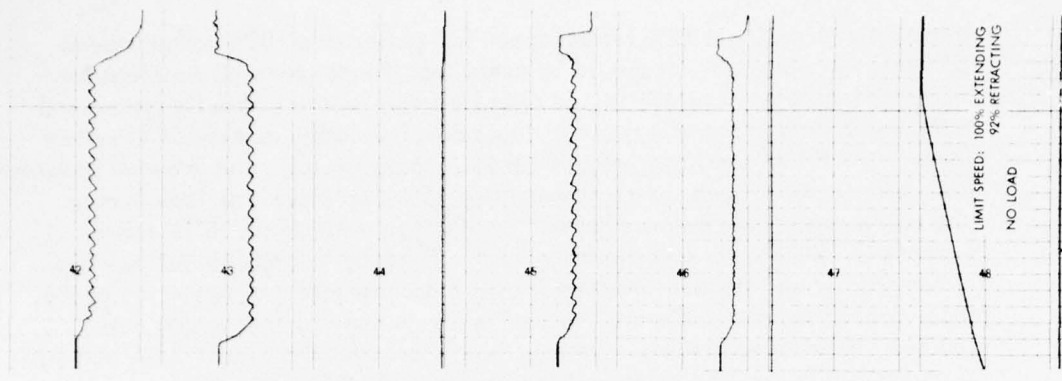

Figure 59 Response of EHPM to Load Exceeding System Capacity

The pulsing nature of flow and pressure reflects the control algorithm used and the resolution available with the 8-bit analog to digital converter (ADC) used to digitize the signal from the pressure transducer. The algorithm causes the speed to be stepped down one notch for each program cycle if pressure is below set point (1500 psi) and to be stepped up one notch per program cycle if pressure is above set point. Although the flap travel data of Figure 59 does not reflect this pulsing, the EHPM did pulse. An approach to smoothing this pulsation is to increase the time between speed changes if the pressure is near the set point. For example, if the pressure is above 2000 psi the time between speed changes could be the normal .015 ms and if it is below 2000 psi it could be .15 ms. Selection of this value by trial should select the lowest value which will give acceptably smooth operation. Higher resolution of the pressure would allow adjusting speed within a narrower pressure range.

To evaluate this pulsation throughout the full range of flow inadequacy the speed of the engine pump was gradually decreased until flow was about 5 gpm. The recorded data for this run is shown in Figure 60. The pulsing nature of flow and pressure is evident, however the program did control the speed at the available reduced flow.

Further attempts to smooth this pulsation were limited by time.

Failure Mode Tests - Hydraulic failure mode testing was conducted by decreasing system pressure to less than 1200 psi to demonstrate the shut-off feature in the program. Pressure was decreased by adjustment of the ground cart pump compensator.

Electrical failure modes were accomplished using the durability test arrangement. With the unit running, electrical power to the EPM was interrupted. The test was repeated several times. The unit stopped each time power was interrupted.

It is concluded that the EHPM concept is compatible with a typical aircraft hydraulic system, that pressure surges can be minimized, and that the concept lends itself readily to optimization of performance by adjustments to control parameters in the software program. It is also concluded that the prototype EHPM is inadequate in two respects. (1) The drive screw jams when the valve reaches its travel limit. (2) The effect of high system return pressure and the limited torque capacity of the EPM.

Durability Tests

The durability test set-up is shown in Figure 61 and is schematically the same as Figure 45. A computer program was written to simulate flap operation and to cycle the EHPM a minimum of 5000 cycles in accordance with the following schedule.

Normal Landing Cycles - Definition of one cycle: Starting at 0° flap angle, extend to takeoff and approach position (21 seconds), stop (wait 2 seconds), extend to landing position (5 seconds), stop (wait 1 second), return to 0° flap angle (26 seconds), stop (wait 2 seconds). Total cycle time 56 seconds.

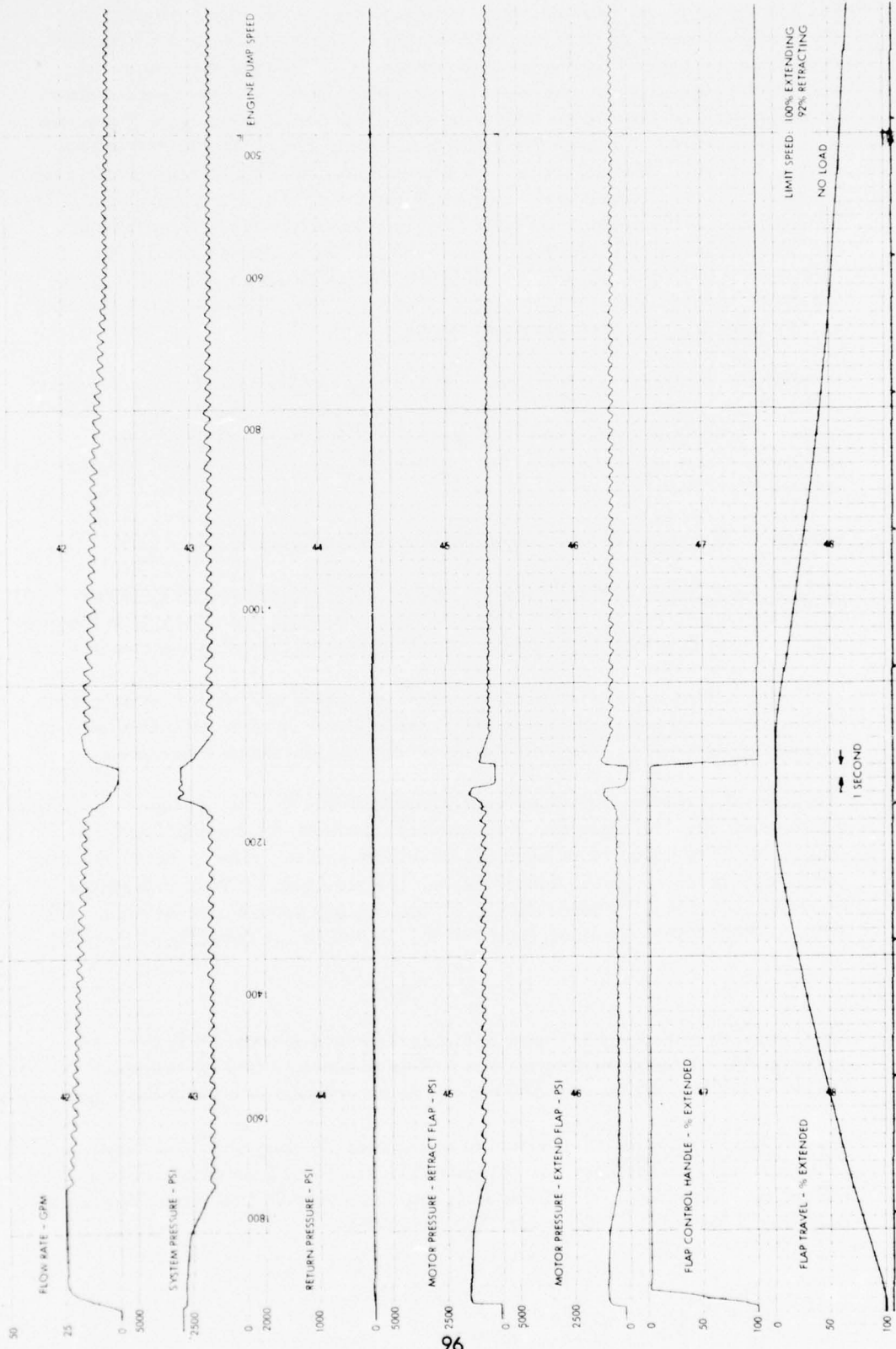

Figure 60 Evaluation of EHPM at Various Levels of Flow Inadequacy

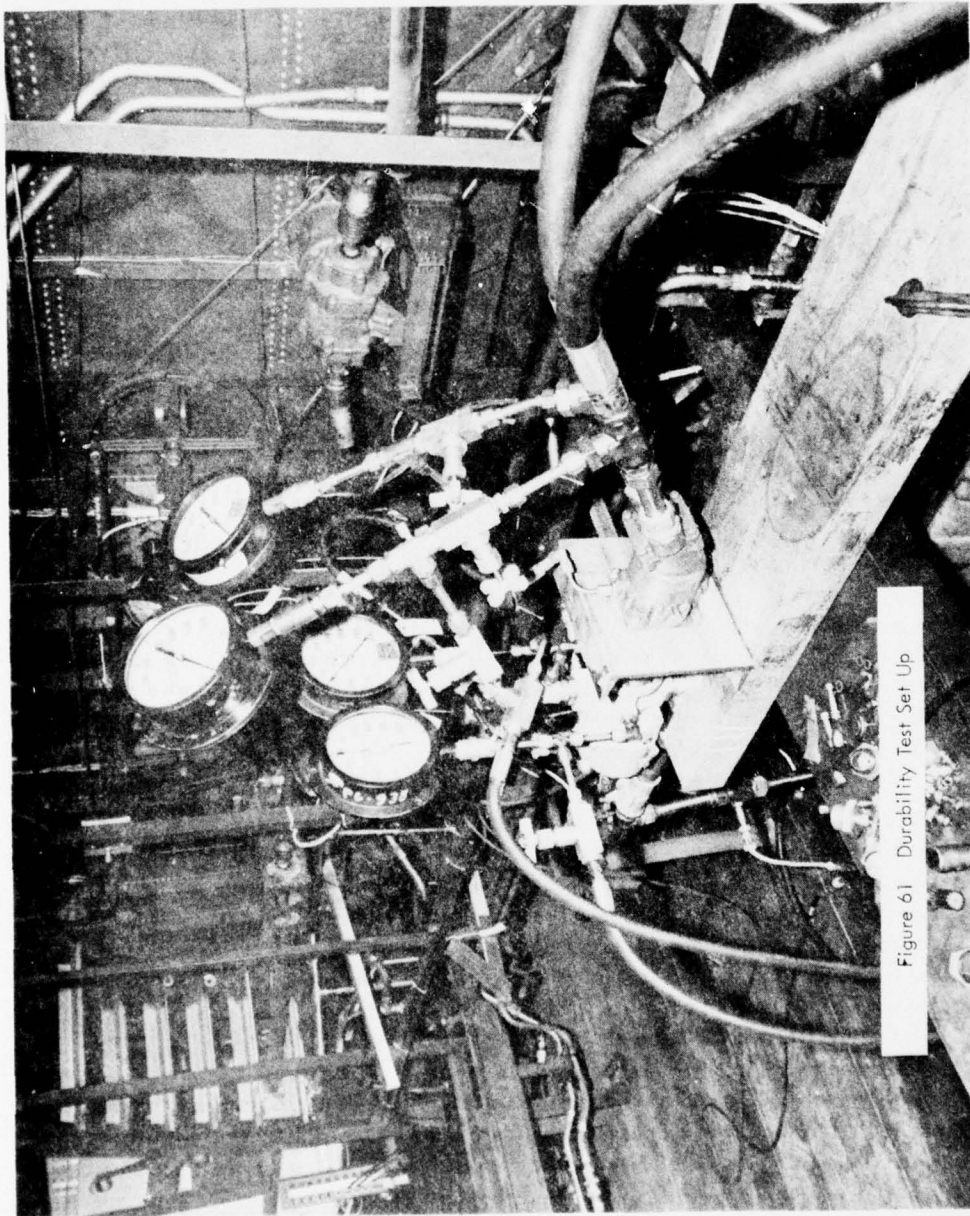

Figure 61 Durability Test Set Up

<u>Load</u>	<u>Cycles Required</u>	<u>Cycles Completed</u>
0	2500	2481
65%	1250	1287
100%	<u>416</u>	<u>472</u>
Sub Total	4166	4240

Touch and Go Cycles - Definition of one cycle: Starting with the flaps at the takeoff and approach position, extend to landing position (3 seconds), stop (wait 2 seconds), return to the takeoff and approach position (3 seconds), stop (wait 2 seconds). Total cycle time 10 seconds.

<u>Load</u>	<u>Cycles Required</u>	<u>Cycles Completed</u>
0	667	709
100%	<u>167</u>	<u>240</u>
Sub Total	834	949
Total	5000	5189

The unit was cycled as shown in Figure 62.

At the startup of each day's testing, several cycles were required before the EHPM would consistently reach limit speed. A procedure to run at some intermediate speed until the warmer system oil was circulated through the unit was established prior to running on the programmed durability cycle tests. The oil temperature was maintained at 100°F through 680 durability cycles and then raised to 150°F for the remaining cycles. After 250 no load, full cycles the unit would not reach limit speed even after warm-up. The unit was disassembled and the outer bearing of the translator nut assembly was found to be rough. The bearing was replaced with a Fafnir 9103K bearing and testing was continued. Later the electric pulse motor was also changed due to a rough bearing in the EPM. Modifications to the return lines were also made to reduce return pressure from 100 psi at 85% to 65 psi at 92% speed. During the tests return, null, and differential ($C_1 - C_2$) pressures increased and internal leakage became excessive. To allow continued operation, the limit speed had to be dropped as shown in Figure 62. The limit speed was reduced to 75% (3000 rpm) prior to the completion of full flap cycle operation at 3602 cycles. Flow recordings taken at various times are shown in Figure 63. Flow recordings were not taken until maloperation of the unit occurred and high internal leakage was suspected. Figure 63 shows that leakage flow was about 2 gpm at cycle number 1904 and about 8 gpm at cycle 5076 and that this leakage is present while stopped and at speed and that internal leakage was again low after repair and reassembly.

<u>Cycles</u>	<u>Load</u>	<u>Speed - % of 4000 RPM</u>		<u>Remarks</u>
		<u>Extend</u>	<u>Retract</u>	
0	0	100	92	
249	0	100	90	Changed nut bearing
958	0	95	90	
1461	Max	95	90	
1538	Max	92	90	
1560	0	90	90	Change EPM
1597	Max	85	85	
1711	0	85	85	System return change
1933	Max	85	85	Trace 4a, 4b
2192	Med	85	85	
3479	0	85	85	
3602	0	75	75	
Touch & Go				
4240	Max	75	75	
4480	Med	75	75	
5189 Complete				Trace 4c

Figure 62 Summary of Durability Cycling

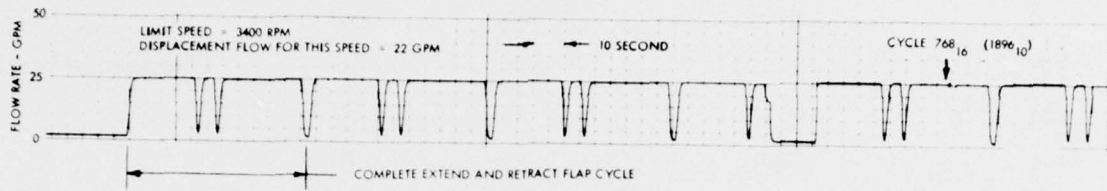

TYPICAL COMPLETE FLAP CYCLES

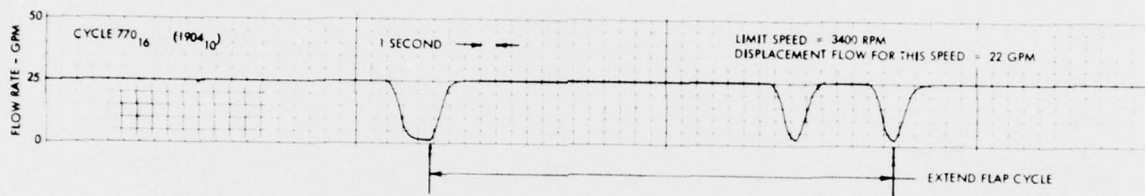

TYPICAL EXTEND FLAP CYCLE WITH FASTER RECORDING

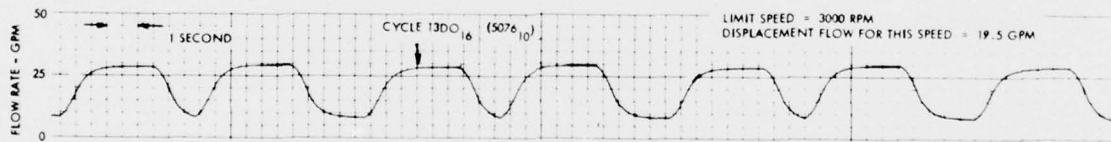

TYPICAL TOUCH AND GO CYCLES HAVING HIGH INTERNAL LEAKAGE

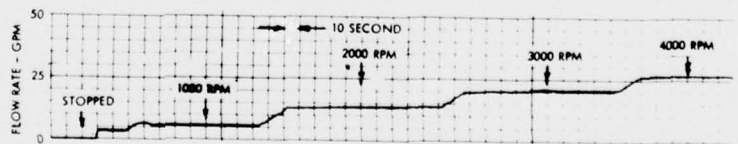

WITH DC MOTOR DRIVE AFTER REPAIR SHOWING LOW INTERNAL LEAKAGE

Figure 63 Durability Flow Tests

After completion of the durability cycles the EPM was replaced with the D.C. motor to run the valve performance tests. During the drag torque tests, when running in the clockwise (CW) direction, a failure occurred that caused the speed to increase followed by a bump and stopping of the unit. Following the failure, a bad seal leak at the EPM gearbox was present when running and the unit would not start with 17 amps current in the CCW direction. A tear-down inspection revealed that the sleeve retaining nuts had loosened allowing the sleeve to move enough for "O" rings to fail - resulting in high internal leakage which prevented normal performance. A retaining pin in the sleeve had also failed, apparently as a result of the valve bottoming out. Two material voids on the spool, shown in Figure 64 were found that appear to be where pieces of chromeplate flaked off. A score was found on the sleeve bore at a position where the flaking occurred on the spool, indicating that the flaking caused the score. Removal of the score by lapping allowed reassembly and completion of the drag torque and leakage tests. The lapping was not in the area of a leakage path. Internal leakage was found to be less than at the beginning of the test program. The disassembled unit is shown in Figure 65 and 66.

Analysis of the failures leads to the following conclusions:

- o The effect of return pressure - increased return line pressure causes the translator nut load and torque to increase until the EPM driving torque is exceeded and the unit stalls. The prototype design allows return pressure to act on the full area of the seal mate, Figure 34, instead of the face seal area only and increases the bearing load by a factor of four. A design change to limit travel of the seal mate would improve the design and reduce the effect of return pressure.
- o Internal leakage caused by sleeve "O" ring seal failures - The progressively deteriorating condition of the EHPM was caused by the increased internal leakage and seal failures. The valve sleeve retaining nuts were loose on disassembly, allowing the sleeve to move and the seals to fail where high differential pressure was present. The retaining nuts are threaded and were loosened by alternate torques transmitted through the sleeve when the translator nut/screw assembly was jammed or on spool/sleeve momentary seizure during the drag torque test following the durability runs. This torque to sleeve condition is not present in purely translational spool/sleeve assemblies but is inherent in the rotating spool concept of the EHPM. An improved method of sleeve retention will fix this problem.

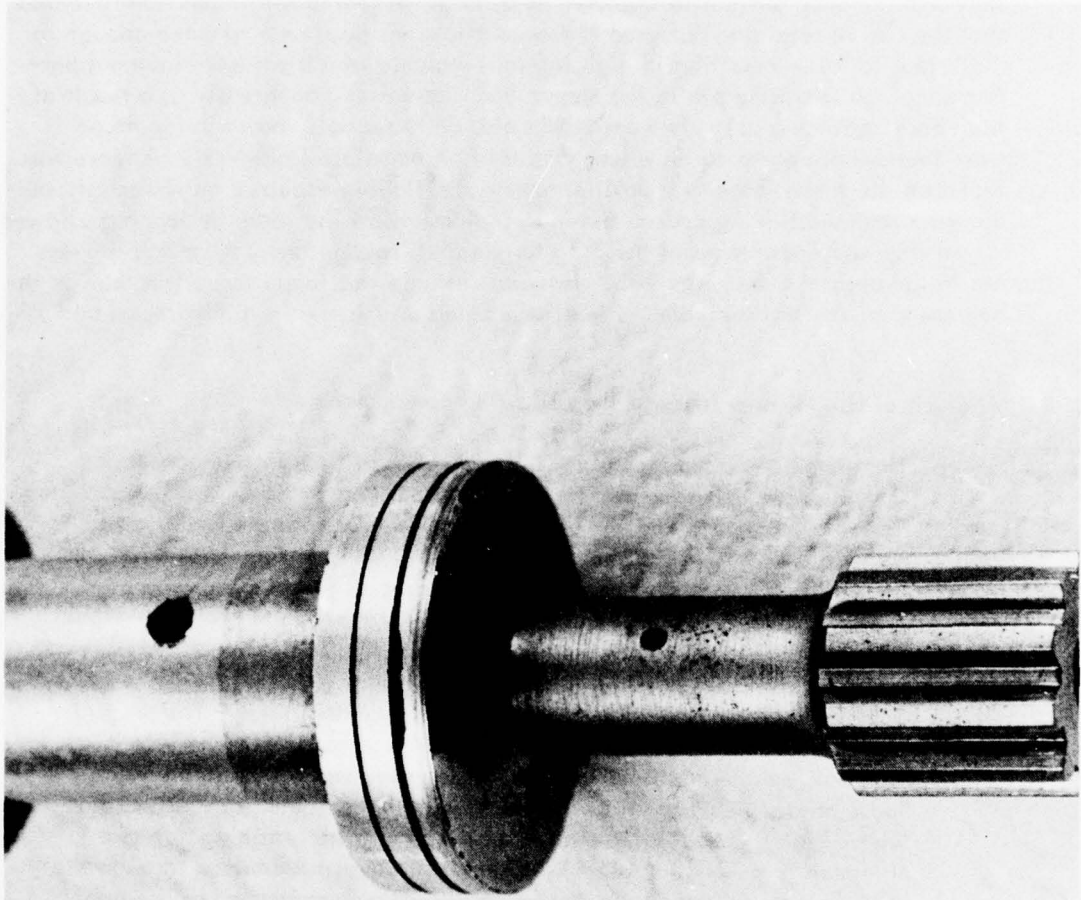

Figure 64 The Valve Spool Showing Material Voids

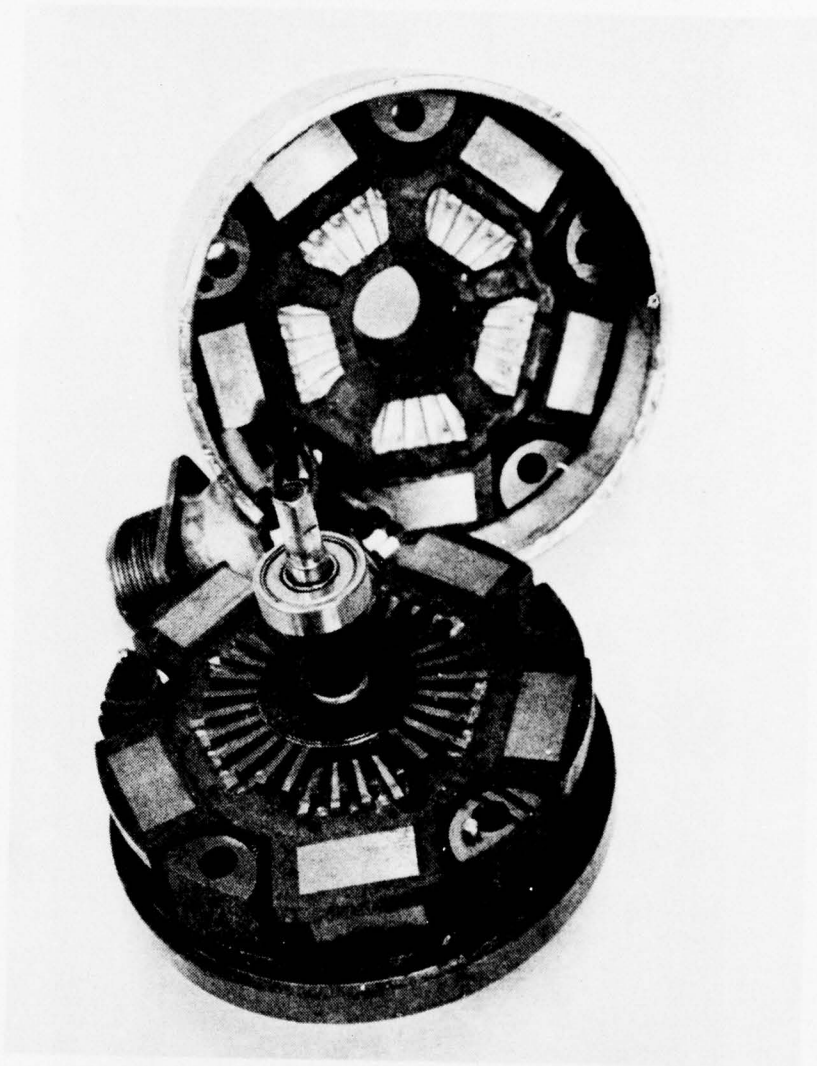

Figure 65 The EPM Disassembled

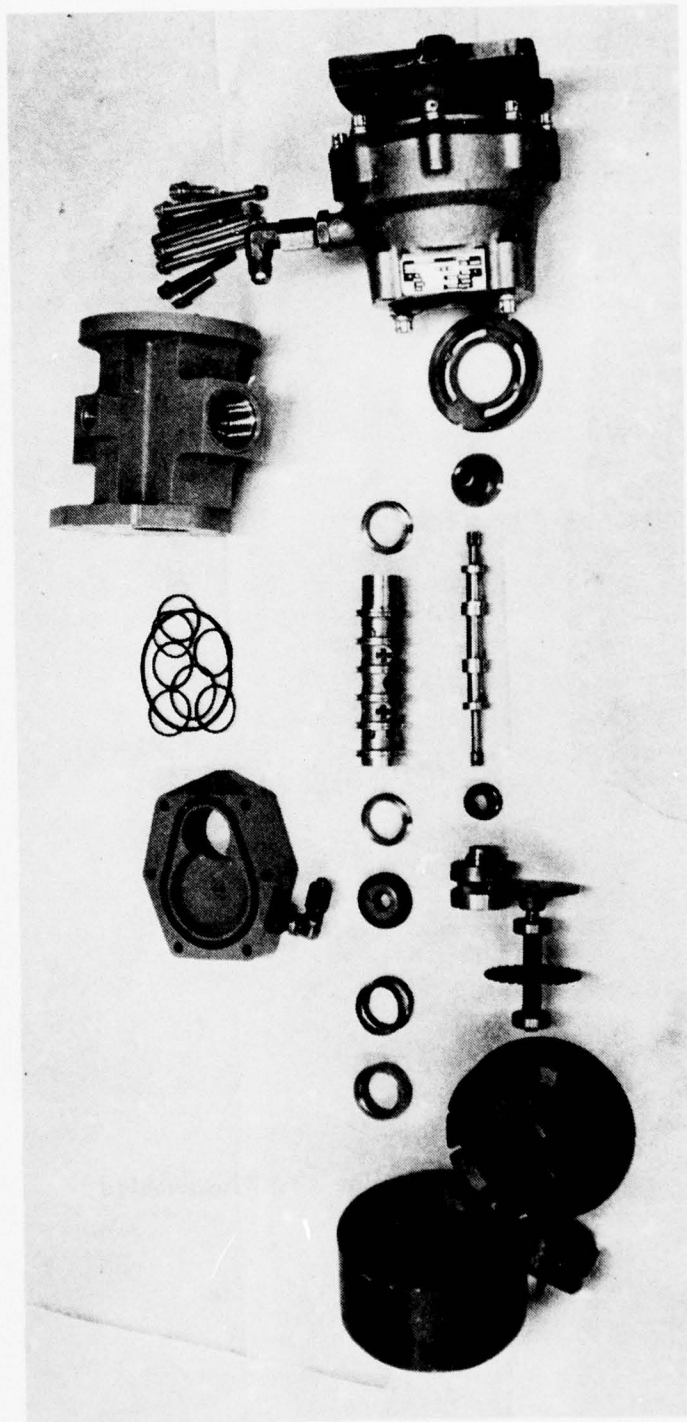

Figure 66 The EHPM Disassembled

- o Spool/sleeve wear or erosion - In the limited durability test, no deterioration or wear of the spool/sleeve assembly was evident on teardown or in the final valve performance tests. It is thought that the momentary seizure during the final valve performance test was caused by separation of the chrome on the repaired spool used in the final assembly.
- o Performance of the unit after repair and assembly - In respect to internal leakage and null pressure performance after repair indicates that some "O" ring damage may have been present at the beginning of the test program.
- o Valve Drag Torque - The valve drag torque measurements shown in Figure 67 indicate a change in torque above 2000 rpm in the CW direction. The original CW torque test shows a drop in torque above 2000 rpm. The later test shows a rise in torque. The rise in torque over the earlier test may be due to the score in the sleeve. The spool is running in about the same position as the score.

It is concluded that wear of the spool and sleeve was negligible; that research for a spool sleeve material and gap combination not dependent on a plating would be a worthwhile effort; and that other failures which occurred are preventable in future designs via state-of-the-art detail techniques.

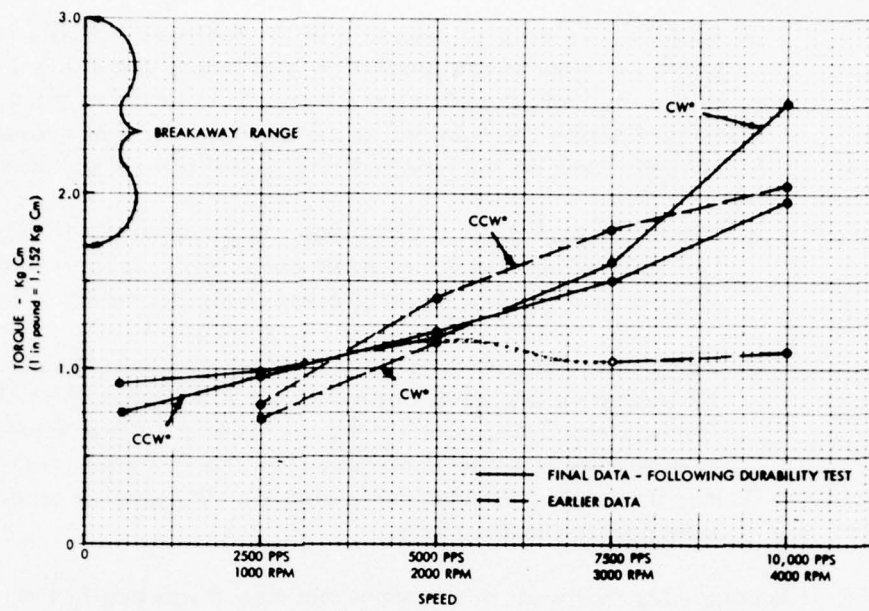

Figure 67 Valve Drag Torques

SECTION VII
CONCLUSIONS AND RECOMMENDATIONS
CONCLUSIONS

State-of-the-Art and Available Hardware - EPM technology and input system technology including the digital computer are adequately developed to support the use of the EHPM concept for aircraft to be designed in the next decade. EHPM's presently in use are not appropriate for aircraft use, but their successful use for machine tools is a significant substantiation for the basic concept. Aircraft EHPM's will not require the high resolution of machine tool units, but will require higher speeds so as to minimize weight.

Component Analysis - The hydraulic motor needs to operate at a higher speed than the EPM so that the EPM can operate on the higher portion of its torque curve. The resolution of the aircraft EHPM can be several orders of magnitude less than the machine tool unit so this EPM speed reduction is achievable. All loads including inertia and viscosity reflected to the EPM need to be minimized and need to be dependable. The size and weight of the EPM needs to be reduced. These conclusions lead to a singular conclusion; namely, the EPM should operate a pilot section which in turn hydraulically positions the main spool. The pilot section is constructed as small as physically feasible and arranged so that pressure loads are balanced and viscous and inertia loads are nil.

Open Versus Closed Loop - The arrangement used for the Iron Bird tests where the input is an absolute binary encoder and an identical encoder is driven by the output of the system is considered to be an excellent approach for aircraft utility and secondary flight control subsystems. The system operates open loop for acceleration and speed control but closed loop for position control. As was done, pressure signals close the loop when necessary. Open loop may be useful for some applications which involve loads that will never exceed design values or where failure is of little consequence. Open loop can be used only if the EHPM always has the capability of achieving the motion corresponding to the EPM motion. If the power demand exceeds the power capability the valve will bottom out, and the EPM will stop. With the arrangement used in the flap drive system the output encoder is examined to determine if it has stopped, and if it has the EHPM is restarted. If the unit is arranged so that bottoming out does not jamb it, so that the only result is to stop the EPM, then the flap drive systems offers a good solution. If the EPM is used only within its start-stop range of speeds and limit switches are provided, open loop could be used between the limits. It is concluded, however, that for most applications the loop should be closed as was done in the flap drive system. The hardware used for closing the loop - i.e. encoders vs. other types of position sensors needs further study to assure minimum cost.

Prototype EHPM Design - Non-jamming thread stops are needed on the translator. The valve sleeve retaining nuts need positive locking, and the sleeve should have a torque tie to the body other than the retaining nuts. The face mating seal needs support to the body so that return pressure will not force it against the nut bearings. The vent passages in the spool should vent the spool ends to the hydraulic motor case but not to the valve return. The EPM torque is not adequate for the design.

RECOMMENDATIONS

Additional Testing - Several areas of additional testing using the equipment developed in this program can add economically to EHPM technology. Spool and sleeve material combinations and clearances need to be evaluated. The chrome plated spool used in this program apparently caused a failure and if unplated material can be used the plating-failure mode can be eliminated. It is also feasible to modify the design of the new sleeve and spool specimens so that return pressure will not load up the nut bearings. The new specimens should be subjected to the durability test.

Additional programming with operational evaluation to smooth out the pressure control functions and to evaluate acceleration limits should be performed. The latter item involves programming the computer so that at each speed the maximum acceptable acceleration to the next step is found. The data obtained allows selection of an accelerations ramp with a known margin.

Conceptual Design - Conceptual designs using a pilot section and a speed reduction between the hydraulic motor and the valve and overcoming the faults discovered in this program should be developed. Layout studies already accomplished indicate a high probability for success of this effort. This effort should investigate other alternatives.

Black Box Definitions - A black box which can control any subsystem or parts of various subsystems and whose functions can be standardized so that only the program has to be different for different applications appears to be a realistic concept. Studies leading to the definition of the functional requirements for such a control should be pursued.

Linear Actuator - The EHPM concept is applicable to linear actuator control and the approach appears to be a viable alternative for thrust reverser control and cargo ramp control where multiple actuators must operate synchronized. A conceptual design study for such a device based on the C-5 thrust reverser requirement should be accomplished.

Application Studies - Preliminary design studies for applications where the pay-off appears to be significant should be performed. The thrust reverser application, ala C-5 requirement, is especially appropriate. The basic requirement is applicable to future systems, and a cursory analysis of the C-5 system indicates a high probability for a good pay-off.

Systems Studies - The basic system approach used for the Iron Bird tests is believed to typify the control system of the future. The selected elements used in this program, their concepts and their packaging do not, however, portray the technology which is to be used in a production system. The trend, though, in the technology for these elements is obviously leading to costs, size, weight, and performance that will make the approach irresistible. Studies need to be made in the areas of packaging, i.e. where to put the various functions; position feedback elements, i.e. what concept is

optimum to perform the encoder functions; computer capability requirements, i.e. how fast and how much memory; and programming techniques, i.e. how to make the system react smoothly to the various forcing functions.

APPENDIX A

GLOSSARY OF TERMS

This section is divided into the following sections: EHPM, EPM and Input Control System. Most of this information was obtained from References 1 and 2.

Electrohydraulic Pulse Motor - EHPM

An electrohydraulic pulse motor, referred to in the literature by two acronyms, EHPM and EHSM, is a power amplifier which, in combination with its electronic control, transforms a stream of low power electrical pulses into high power rotary motion. Above some low speed the rotary motion is smooth and not pulsatory. The displacement of the hydraulic motor shaft is proportional to the number of pulses delivered; the speed is proportional to pulse rate; and the acceleration is proportional to the change in pulse rate. All of these can be controlled in open loop. The EHPM consists of an EPM which is mechanically connected to a four-way valve such that a displacement of the EPM causes the valve to translate and deliver flow to the hydraulic motor whose rotation causes the valve displacement to be cancelled. The arrangement causes the hydraulic motor to follow the EPM. Some terms which are used in EHPM technology are defined as follows:

Translator Driver - this term has been used twice in the current program. In one case it is the threaded nut within the EHPM which causes the spool to translate when the EPM rotates and in the other it is the Icon 601-T electronic package which includes a 28-volt power supply, a logic circuit to convert pulses to sequential energization of the five power amplifiers which supply the higher electrical power to the five EPM coils.

Electrical Pulse Motor - the electrical pulse motor referred to in the literature by two acronyms, EPM and ESM, is the input device of the EHPM and because of its important role its description and the terms used in its technology are presented under a separate heading which follows next in this glossary.

Electrical Pulse Motor (EPM)

Accuracy - The step positions in a motor are determined by dimensions of the parts and assemblies built into it during manufacturing. Tolerances in these dimensions result in tolerances in step positions from the nominally correct locations. This is termed accuracy and is expressed as a maximum angular dimension. For example, a maximum error of 0.25 degree in a 24-step-per-revolution (15 degrees/step) could be given as a $\pm 1.67\%$ accuracy. Accuracies of commercially available motors range from $\pm 5\%$ to as low as $\pm 1\%$.

These built-in position errors are systematic, or repeatable, for any given motor, and noncumulative. They occur under all load conditions. Loads involving significant internal friction are subject to an additional nonrepeatable positional error. This more-or-less random error is unrelated to the built-in motor accuracy, although the two types of error are additive in the system. This error is also noncumulative. The value of this error can be obtained from a plot of the holding torque.

Efficiency - The power out of the stepping motor divided by the power into the driver. This ranges from 0, when the motor is just holding, to 10% at best, when the motor is running. Steppers are positioning devices, and are very poor at energy conversion.

Note that this low efficiency applies to the stepper only; the efficiency of the hydraulic motor is far higher. Also, the low efficiency of the stepper reduces the efficiency of the electrohydraulic system only slightly because the power input into the stepper is a small fraction of 1 hp, while the hydraulic motor may involve many horsepower.

Inductance - All motor windings have self-inductance and many motors also have mutual inductance. Mutual inductance is essentially nonexistent in multiple-stack VR motors. When the term inductance is used, it commonly means the self-inductance. The inductance varies with the rotor position and current in the winding. The inductance is highest with rotor and stator teeth aligned and no current flowing in the winding.

Internal Inertia - The internal inertia of the motor is useful in evaluating the effect of load inertia on motor performance. However, due to the unique time-variant and non-linear nature of motor torque, the conventional torque-to-inertia or torque-squared-to-inertia ratios are of questionable value for other than rough comparison purposes. Rotor inertia includes the inertias of all rotating components. When selecting a motor, the rotor inertia must be included in the calculations.

Minimum-Response-Time Curves - The minimum-response-time curves are much more useful than pull-in torque curves. They indicate the minimum transit time to travel the indicated distance, given in degrees for each curve, with an inertial load (no friction) rigidly coupled to the motor shaft. The values of the load inertia are given along the abscissa on a logarithmic scale. The time in seconds/cycle covers the start-from-rest through return-to-rest at the end of travel. The curves for short motions are obtained with some form of damping. For long motions, the transit time is determined by accelerating and decelerating the motor. The last pulses are timed to cause the motor to have zero velocity at the time it arrives at the final position. If the motor has some velocity as it reaches final position, it will ring and additional settling time is required.

Resolution - Resolution is expressed as the number of steps per revolution, or step angle in degrees. This is an unalterable, built-in characteristic of stepper motors.

The VR and PM motors are available in the range of 1 to 500 steps/revolution. The nutating disc and flexspline types, from 400 to 2000 steps/revolution.

Resonance - EPM's have a natural frequency. Stepped at their natural frequency, they will resonate and lose step. They will go through resonant speed error-free. Inertia load rigidly coupled to the motor shaft lowers the natural frequency and resonance.

Speed - EPM speeds are normally given in steps per second. Dividing the steps per second (speed) by the steps per revolution (resolution) and 60 seconds gives the shaft speed in revolutions per minute (rpm). The following types of speed are encountered in EPM technology:

- o Start-stop speed is the highest step rate to which the motor will respond without step loss during starting and stopping.
- o Slew speed is generally the fastest speed at which the motor will run unloaded with very slow acceleration.

Stepper Motor (EPM) or (ESM) - Devices, generally electromechanical, which in response to a signal input, assume a known position. The signal may contain the necessary power to shift the load, but generally does not in the larger sizes of steppers. Four main types - variable reluctance, permanent magnet, nutating disc, and flexspline - are compared as follows:

- o Variable reluctance (VR) and permanent magnet (PM) motors both generally have a rotor and stator with teeth. Energizing a coil creates magnetic flux which aligns the teeth. Different coils cause different teeth to align and permits sequential stepping. PM types have a permanent magnet in the circuit which aids or bucks the flux induced in the coils. PM types have a detent action when electrical power to the coils is removed.
- o Nutating disc type steppers have a wobble disc with two sets of low angle bevel gears connecting the disc to the output shaft. Solenoids positioned in a circle sequentially attract the disc, rotating the shaft.
- o Flexspline motors use a thin wall flexible cylinder with minute gear teeth on the outside and thin layers of coiled magnetic material on the inside. Radially positioned solenoids attract the magnetic material, distorting the cylinder into an oval shape. The gear teeth at the high points engage a rigid internal spline. Sequentially energizing the solenoids moves the points of contact. A 2-tooth difference causes the flexspline to rotate small amounts. The output shaft connects to the flexspline.

Torque - The following types of torque are encountered in EPM technology:

- o Holding torque is the maximum steady torque that can be externally applied to the shaft of an excited motor without causing continuous rotation.
- o Detent torque is the maximum torque which can be applied to a non-energized stepper before the rotor will snap out of position. Only PM motors have significant detent torque.
- o Stall torque is the maximum torque available while running at a very low speed.

- o Running or pull-out torque is the maximum constant torque load against which the stepper can run error free, after it has reached speed. This is the torque shown in most manufacturer's torque vs. speed curves. This torque measurement is only slightly influenced by inertia loading.
- o Pull-in or torque-to-start-without-error is the maximum torque load that the motor can pull into synchronism with a constant frequency step rate. This torque is determined by putting a fixed torque load on the motor, then giving the motor a constant frequency pulse rate. The pull-in torque is the largest pure torque load against which it can start and remain error free (that is, without any step loss). No inertia load is considered in this definition.

Windup - Stepper shafts will twist under torque loads. The VR and PM types are fairly linear, and exhibit little hysteresis.

Mechanical motors do not exactly have backlash, but the windup is not linear about zero, and there is more hysteresis.

Input System

EPM Electronics - The stepping motor drive system accepts low power IC level pulses and converts them to the proper phase format for the motor windings; a power amplifier then switches the required current through the windings. Choosing the proper drive circuit design is as important as selecting the proper motor.

Some drivers use constant current power supplies; others use constant voltage power supplies. Constant voltage types are simple and inexpensive. Constant current drivers are more complicated, but offer better performance. The characteristics of several types of drivers are as follows:

- o R/L Drives - The coils of the motor have an inductive time constant which limits average coil currents and motor torque at high stepping rates. To reduce circuit time constant, an external resistor is connected in series with the motor coils, permitting an increase in power supply voltage without a corresponding increase in coil current. The net effect is to decrease the

circuit time constant and increase high speed torque. In practice, the voltage "overdrive" is increased to 10 or more times the rated motor voltage. The major disadvantage of using external resistors is the heat which must be dissipated by them and the resulting increase in package space and weight.

- o Uni-Polar vs. Bi-Polar Operation - In the uni-polar one-half of the motor winding is energized alternately for each step and the other half is unenergized. The bi-polar drive operates all coils simultaneously in a push-pull mode through polarity reversal rather than through winding selection. Typically an increase of 30% in output power can be obtained from the same electrical input power to the motor with only a slight increase in circuit cost. Bi-polar R/L drive circuits do, however, require double ended or center tapped power supplies.
- o Bi-Polar Chopper Drives - The chopper drive eliminates the need for external series resistors and provides even higher operating speeds requiring less than one-third of the power consumption than R/L drives. A single high voltage power supply is incorporated with a bi-polar amplifier. The voltage to the motor coil is chopped to maintain rated motor current. The chopping function is controlled by a feedback circuit which continuously senses motor current. Thus, the requirement for current limiting resistors and their related heat dissipation equipment is eliminated. Chopper drives provide the highest torque speed levels, especially in frequent start-stop type applications, can extend the high speed slew range of the motors by a factor of 4-5 times and provide higher torque and speed in the start-stop mode.

The latter type drive is a constant current system.

A Central Processor Unit (CPU) is the control unit of a digital computer.

A Read Only Memory (ROM) is memory which is permanent or semi-permanent in nature and is not changeable by programming the computer and it is not lost when all electrical power goes off, i.e., it is non-volatile. It is used as fixed input to the computer. Its use is limited to being read by the computer. A PROM is programmable read only memory. It is semi-permanent in nature. It can be changed but the change is usually effected by special equipment when the memory is not installed in the using system.

A Random Access Memory (RAM) is memory which is changed during normal operation of the computer. The program can read this memory and can also change it. It is volatile so is lost if electrical power goes off.

APPENDIX B
INPUT CONTROL SYSTEM DESCRIPTION

General - This section provides discussion and diagrams to further define the system, including hardware and software, as it was finally developed.

Computer - The CPU diagram is shown in Figure B-1. The CPU plus memory, both ROM and RAM, make up the Altair 8800 computer. As will be shown in the software section, about 1000, 8 bit words of memory were required. The instruction set is shown in Figure B-2.

Icon 601-T Driver - This unit accepts a low power pulse stream on either of two input lines and transforms it into a sequential energization at high power of 5 output lines. If the outputs are numbered 1, 2, 3, 4 and 5 the pulse stream on one input line will cause the following pattern: 1,2 - 1,2,3 - 2,3 - 2,3,4 - 3,4 - 3,4,5 - 4,5 - 4,5,1 - 5,1 - 5,1,2 - and repeat. A pulse stream on the other input line will cause the following pattern: 1,2 - 5,1,2 - 5,1 - 4,5,1 - 4,5 - 3,4,5 - 3,4 - 2,3,4 - 2,3 - 1,2,3 - and repeat. This unit includes a 28-volt power supply. In an aircraft system the ship's 28-volt supply would be used. The circuit diagram for this unit is shown in Figure B-3. As noted in the basic report, this unit was modified to accept power from a current limiting type power supply which to a degree made the Icon 601-T driver perform like a chopper drive as defined in Appendix A. This modification allowed the external power supply to feed into the 5 power resistors in the EPM motor circuit while retaining the 12-volt internal supply for the 601-T logic circuits.

Encoders - The two encoders used were Model 25H-8NA made by Sequential. They are optical, absolute, and eight bit binary. They were connected as shown in Figure B-4.

Interface Board - The interface board schematic is shown in Figure B-5. This circuit performs the following functions:

- o digitizes the pressure transducer signals so the computer can read a binary number that represents pressure
- o converts two 8-bit binary words (i.e., 16 bits) output from the computer to direction and speed signals compatible with the Icon driver. This function is discussed further under the heading, Speed and Direction Control, which follows next in the text.
- o multiplexes the computer input and output lines to facilitate reading the two encoders and the pressure signal and outputting the speed, direction and shut-off valve signals.
- o Latches signals as necessary.

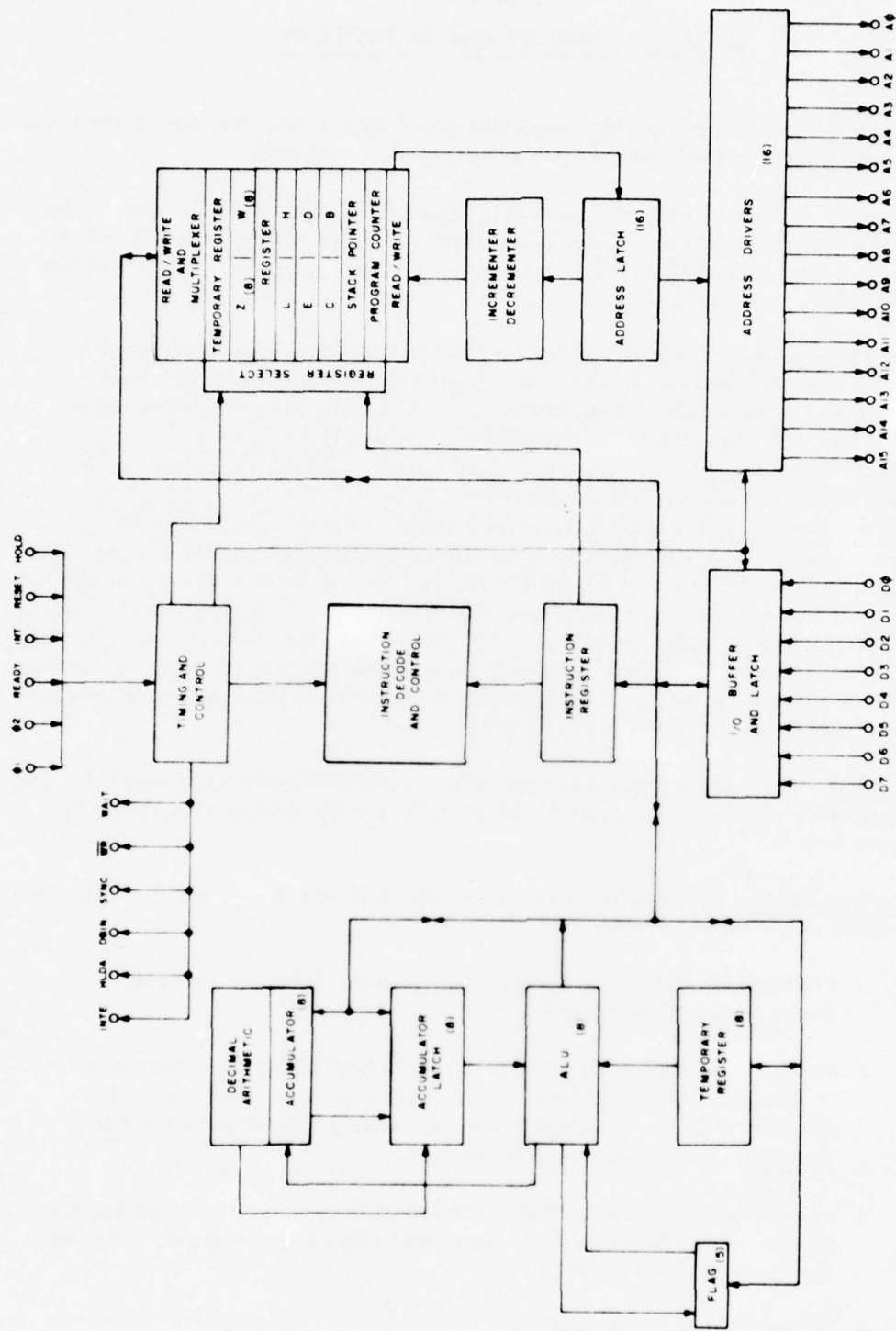

Figure B-1. CPU Diagram

BEST AVAILABLE COPY

Mnemonic	Description	Clock * Cycles	Mnemonic	Description	Clock * Cycles
MOV r1, r2	Move register to register	5	RZ	Return on zero	5/11
MOV M, r	Move register to memory	7	RNZ	Return on no zero	5/11
MOV r, M	Move memory to register	7	RP	Return on positive	5/11
HLT	Halt	7	RM	Return on minus	5/11
MVI r	Move immediate register	7	RPE	Return on parity even	5/11
MVI M	Move immediate memory	10	RPO	Return on parity odd	5/11
INR r	Increment register	5	RST	Restart	11
DCR r	Decrement register	5	IN	Input	10
INR M	Increment memory	10	OUT	Output	10
DCR M	Decrement memory	10	LXI B	Load immediate register Pair B & C	10
ADD r	Add register to A	4	LXI D	Load immediate register Pair D & E	10
ADC r	Add register to A with carry	4	LXI H	Load immediate register Pair H & L	10
SUB r	Subtract register from A	4	LXI SP	Load immediate stack pointer	10
SBB r	Subtract register from A with borrow	4	PUSH B	Push register Pair B & C on stack	11
ANA r	And register with A	4	PUSH D	Push register Pair D & E on stack	11
XRA r	Exclusive Or register with A	4	PUSH H	Push register Pair H & L on stack	11
ORA r	Or register with A	4	PUSH PSW	Push A and Flags on stack	11
CMP r	Compare register with A	4	POP B	Pop register pair B & C off stack	10
ADD M	Add memory to A	7	POP D	Pop register pair D & E off stack	10
ADC M	Add memory to A with carry	7	POP H	Pop register pair H & L off stack	10
SUB M	Subtract memory from A	7	POP PSW	Pop A and Flags off stack	10
SBB M	Subtract memory from A with borrow	7	STA	Store A direct	13
ANA M	And memory with A	7	LDA	Load A direct	13
XRA M	Exclusive Or memory with A	7	XCHG	Exchange D & E, H & L Registers	4
ORA M	Or memory with A	7	XTHL	Exchange top of stack H & L H & L to stack pointer	18
CMP M	Compare memory with A	7	SPHL	H & L to stack pointer	5
ADI	Add immediate to A	7	PCHL	H & L to program counter	5
ACI	Add immediate to A with carry	7	DAD B	Add B & C to H & L	10
SUI	Subtract immediate from A	7	DAD D	Add D & E to H & L	10
SBI	Subtract immediate from A with borrow	7	DAD H	Add H & L to H & L	10
ANI	And immediate with A	7	DAD SP	Add stack pointer to H & L	10
XRI	Exclusive Or immediate with A	7	STAX B	Store A indirect	7
ORI	Or immediate with A	7	STAX D	Store A indirect	7
CPI	Compare immediate with A	7	LDAX B	Load A indirect	7
RLC	Rotate A left	4	LDAX D	Load A indirect	7
RRC	Rotate A right	4	INX B	Increment B & C registers	5
RAL	Rotate A left through carry	4	INX D	Increment D & E registers	5
RAR	Rotate A right through carry	4	INX H	Increment H & L registers	5
JMP	Jump unconditional	10	INX SP	Increment stack pointer	5
JC	Jump on carry	10	DCX B	Decrement B & C	5
JNC	Jump on no carry	10	DCX D	Decrement D & E	5
JZ	Jump on zero	10	DCX H	Decrement H & L	5
JNZ	Jump on no zero	10	DCX SP	Decrement stack pointer	5
JP	Jump on positive	10	CMA	Compliment A	4
JM	Jump on minus	10	STC	Set carry	4
JPE	Jump on parity even	10	CMC	Compliment carry	4
JPO	Jump on parity odd	10	DAA	Decimal adjust A	4
CALL	Call unconditional	17	SHLD	Store H & L direct	16
CC	Call on carry	11/17	LHLD	Load H & L direct	16
CNC	Call on no carry	11/17	EI	Enable Interrupts	4
CZ	Call on zero	11/17	DI	Disable interrupt	4
CNZ	Call on no zero	11/17	NOP	No operation	4
CP	Call on positive	11/17			
CM	Call on minus	11/17			
CPE	Call on parity even	11/17			
CPO	Call on parity odd	11/17			
RET	Return	10			
RC	Return on carry	5/11			
RNC	Return on no carry	5/11			

*Two possible cycle times indicate that instruction cycles are dependent on condition flags. 4 Clock Cycles = 2 μ s

Figure B-2. Microcomputer Instruction Set

BEST AVAILABLE COPY

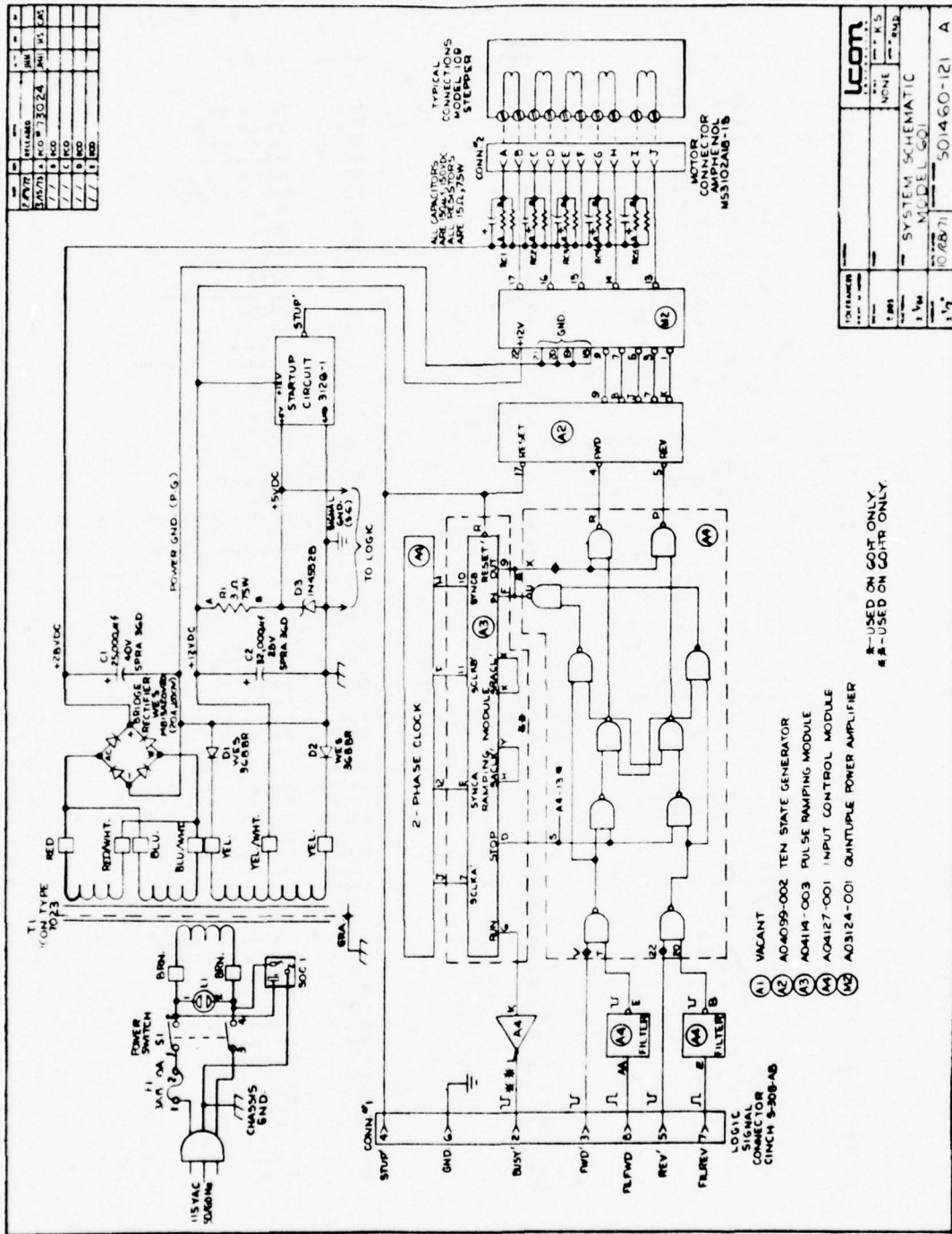
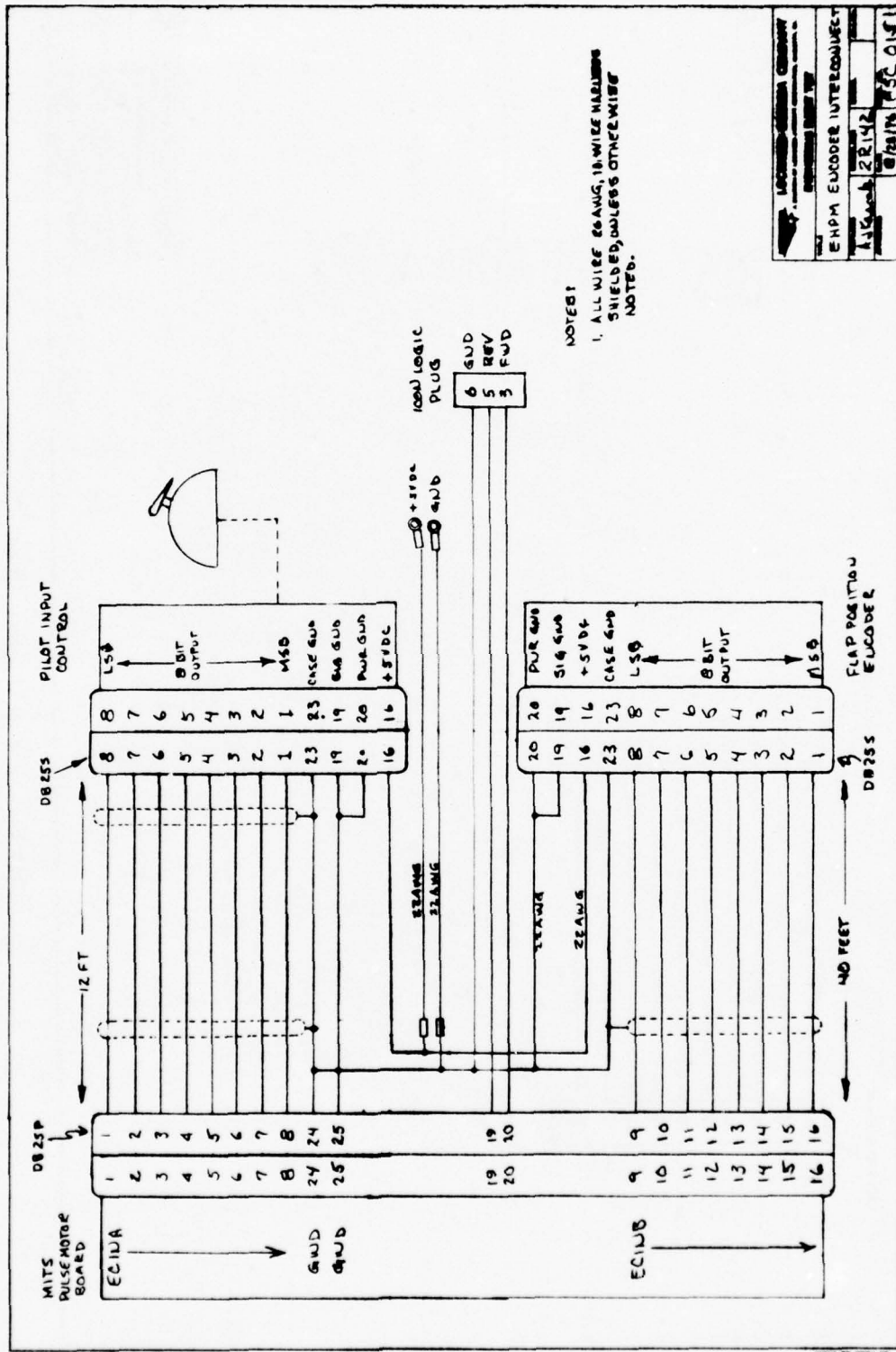

Figure B-3. ICON 601-T Driver



LOGIC BOARD CONTROL	28142
ENPM ENCODER INTERCONNECT	28142
DATE	8/22/76
BY	PSO Q181

Figure B-4. Wiring Diagram (Sheet 1)

BEST AVAILABLE COPY

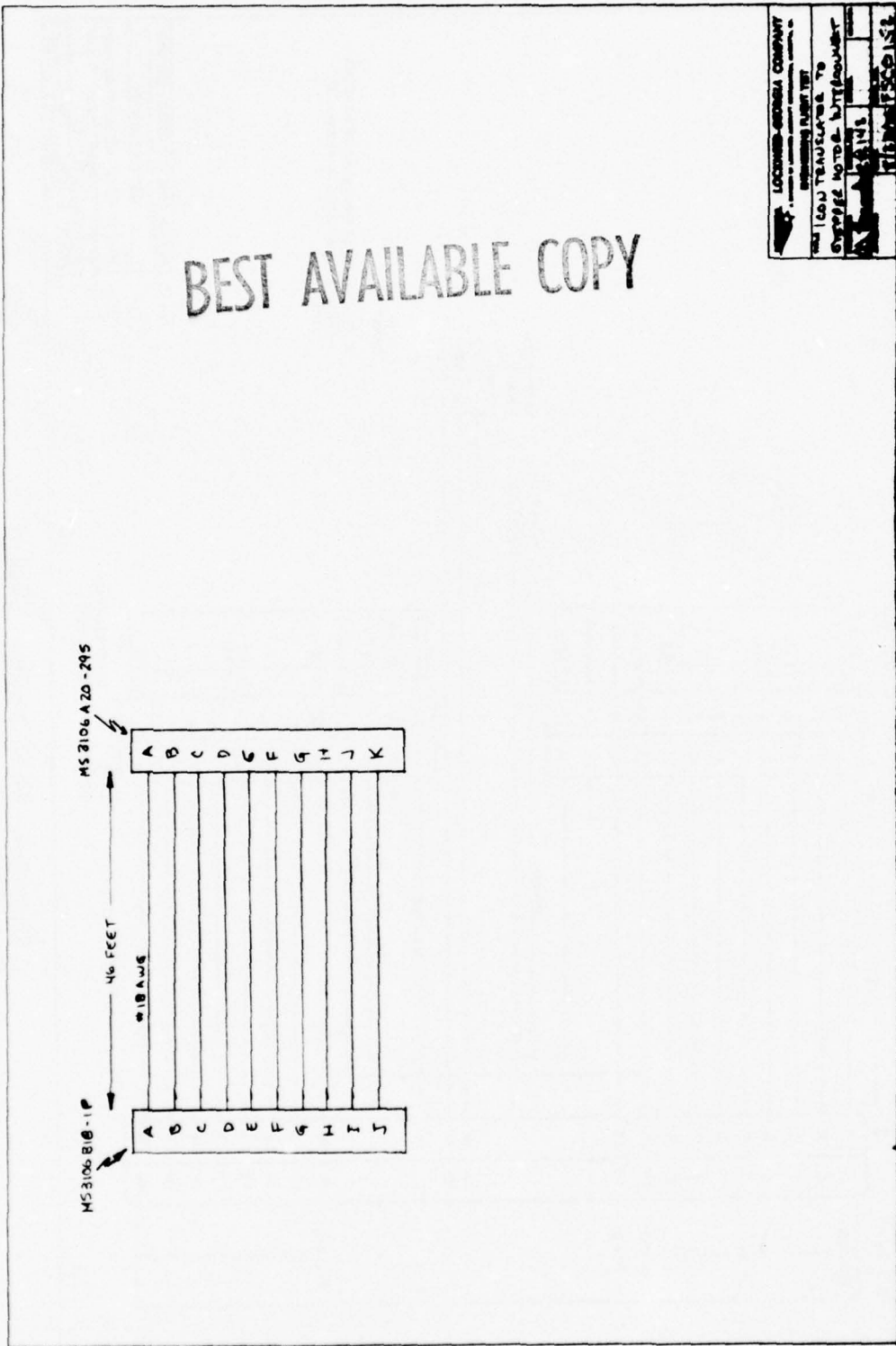

LOCKHEED-GEORGIA COMPANY
1000 TRAILWAY TO
CROSSING NORTH WILLOWBURY
ATLANTA, GA 30343
TELEPHONE 478-5212

Figure B-4. Wiring Diagram (Sheet 2)

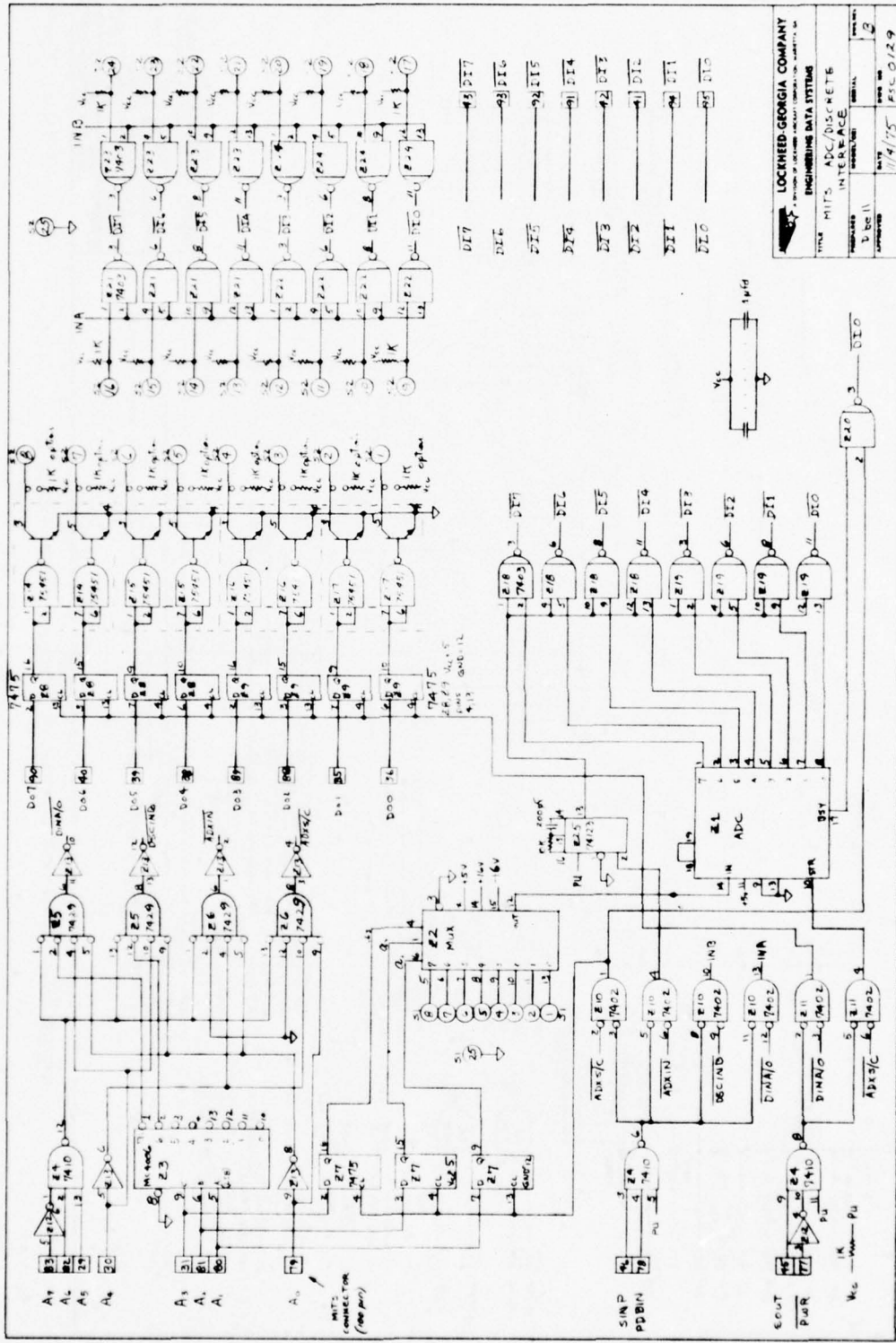
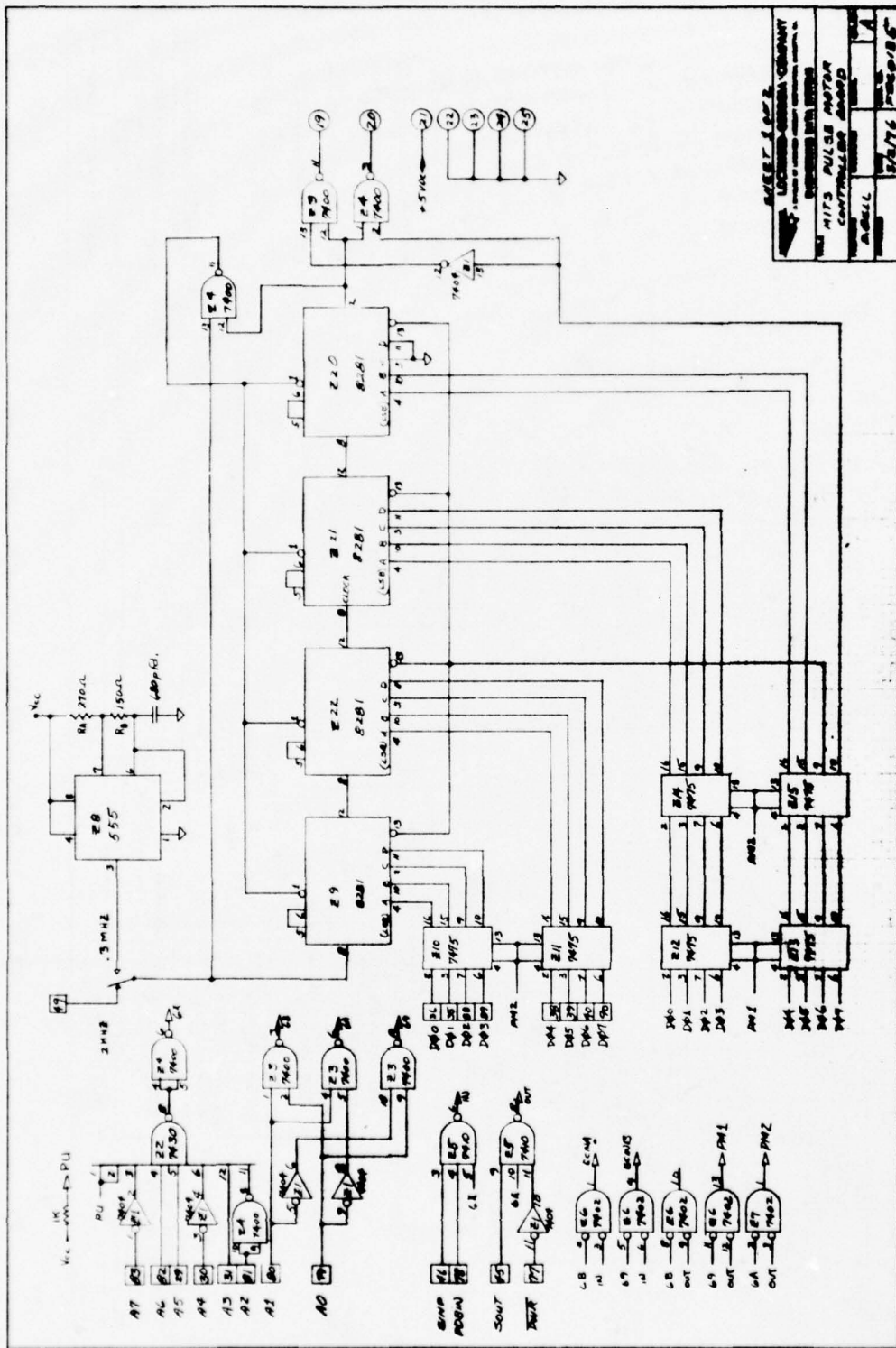

Figure B-5. Schematic Diagram of Interface Board (Sheet 1)

BEST AVAILABLE COPY



SHEET 2 OF 2
 LOCKHEED-HEWLETT COMPANY
 11111 WILLOW AVENUE
 BELLWORKS
 BETHESDA, MARYLAND 20814
 MITS PULSE MOTOR
 CONTROLLER BOARD
 MODEL
 01A/76
 1/76

Figure B-5. Schematic Diagram of Interface Board (Sheet 2)

BEST AVAILABLE COPY

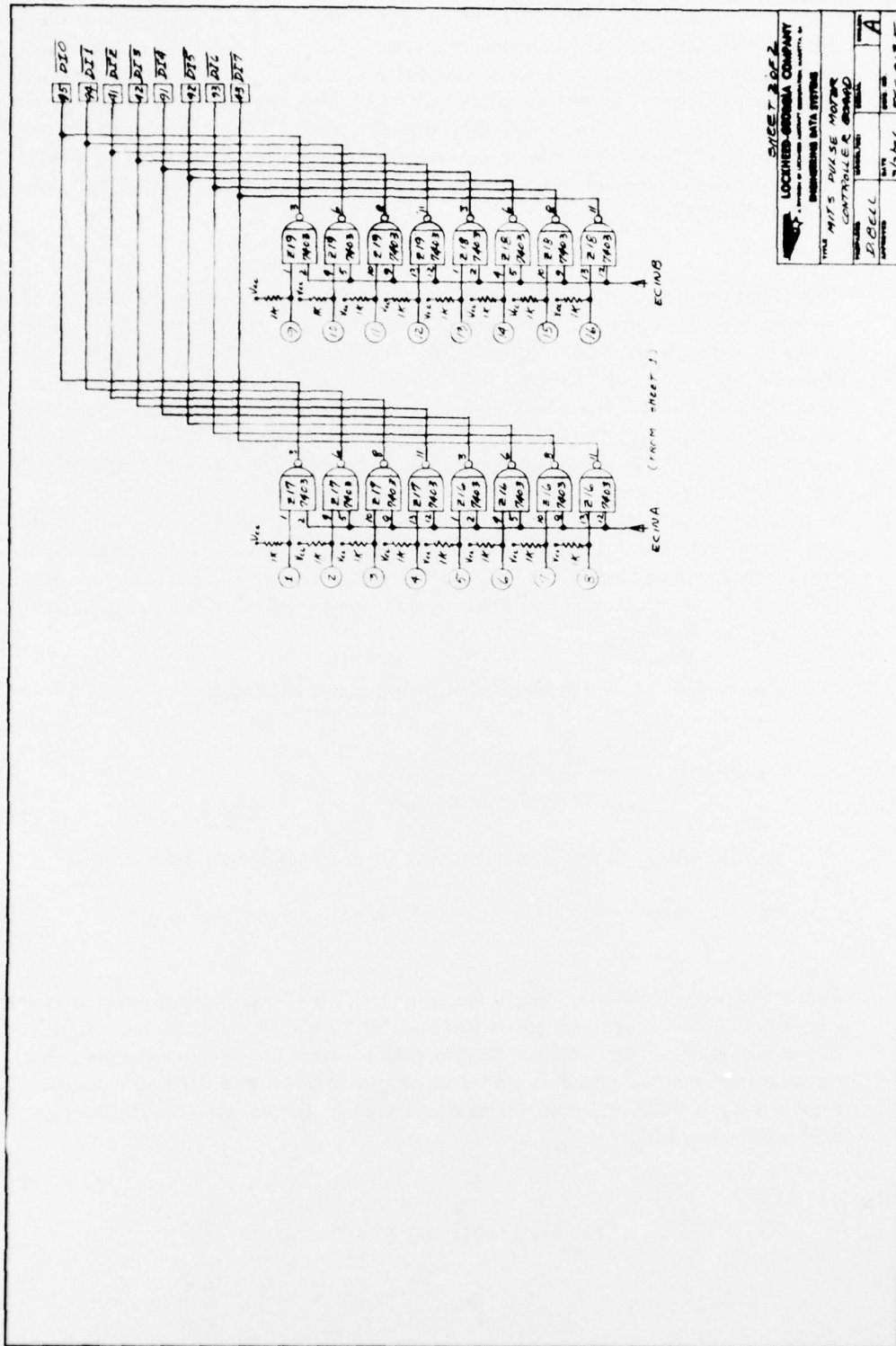

SHEET 3 OF 2	
LOCATED-ORIONA COMPANY	
BUSINESS DATA SYSTEMS	
TITLE: MITS PULSE MOTOR CONTROLLER BOARD	
DESIGNED BY:	DATE: 5/17/66
DRAWN BY:	SCALE:
CHECKED BY:	APPROVED BY:
DATE: 5/17/66	PC: 0135

Figure B-5. Schematic Diagram of Interface Board (Sheet 3)

Speed and Directional Control - The function of the speed control circuit is to control the frequency of a pulse train. The computer works with binary numbers and uses a binary signal to represent speed. The speed control circuit transforms the binary number into a frequency or pulse rate which is related to the value of the binary number. Direction is controlled by steering this frequency onto one of two lines. One line causes CW rotation, the other CCW. These two lines are inputs to the 601-T driver which converts the low power pulse train to a sequential pattern of high power electrification of the 5 output lines of the driver, i.e., the coils of the EPM.

The speed control circuit in essence consists of a 14-bit binary counter, a clock feeding into the counter, a preset system which will preset the bits of the counter using a binary signal from the computer, and a logic system to determine when all bits of the counter are the same and deliver a pulse when they are the same. It operates as follows: The clock, which is operated at 2×10^6 pps, causes the counter to rip, i.e., the counter counts the clock pulses. When all bits are the same, the output line is energized causing one pulse in the pulse train that is the input to the Icon driver. The time between the pulses so generated depends on how many counts that are required to change the counter from the state where all bits are the same to the next state where all bits are the same. This number of counts can be selected by presetting various bits of the counter; i.e., the time required for the counter to count a full count is controlled and each time a full count occurs a pulse is generated.

The relationship is defined by the following speed equation:

$$\text{Speed (pps)} = \frac{\text{Clock rate}}{16,383 - \text{Preset number}}$$

16,383 = Base 10 value of full count in a 14-bit binary counter

Preset Number = Base 10 value of the binary preset number.

The binary preset number used in the program is a 16-bit number and the two most significant bits are used for direction and "go" control. The 14 least significant bits make up the preset number for the above equation. As an example, the hexadecimal number which is stored at addresses 016A and 016B of memory, Figure B-6, is FEB2 and constitutes one complete binary speed and directional control number which is

```

F   E   B   2
1111 1110 1011 0010

```



```

0210 : 7F 15 7F 17 7F 19 7F 1B
0218 : 7F 1C 7F 1E 7F 1F 7F 20
0220 : 7F 21 7F 22 7F 23 7F 24
0228 : 7F 25 7F 26 7F 27 7F 28
0230 : 7F 29 7F 2A 7F 2B 7F 2C
0238 : 7F 2D 7F 2E 7F 2F 7F 30
0240 : 7F 31 7F 32 7F 33 7F 34
0248 : 7F 35 7F 36 7F 37 00 00
0250 : E3 E3 E3 BA 00 00 00 A6
0258 : 01 A6 01 4D 60 BA 00 00
0260 : 3A 5D 02 47 3A 53 02 4F
0268 : 32 5D 02 90 E6 0F 07 00
0270 : 00 00 47 79 90 47 3A 5C
0278 : 02 C9 00 00 00 00 00 00
0280 : 3E 00 D3 69 D3 6A 32 54
0288 : 02 32 55 02 3A 51 02 32
0290 : 52 02 2A 57 02 22 59 02
0298 : 3E C9 32 4D 00 00 00 00
02A0 : 3A 4E 00 FE 02 C2 A0 02
02A8 : 3D 32 4E 00 3A 4D 00 3D
02B0 : FE 00 C2 B7 02 3E 65 32
02B8 : 4D 00 FE 01 C2 D0 02 3A
02C0 : 52 02 47 3A 51 02 32 52
02C8 : 02 B8 CA D0 03 00 00 00
02D0 : DB 69 2F C6 03 32 51 02
02D8 : 47 2A 59 02 29 29 29 29
02E0 : 3E 1A 94 00 00 00 4F 78
02E8 : 91 47 DB 6B 32 50 02 90
02F0 : CA B0 03 DA 30 03 C3 70
02F8 : 03 00 00 00 00 00 00 00
0300 : 00 00 00 00 00 00 00 00
0308 : 2A 59 02 EB 13 13 1A D3
0310 : 69 32 54 02 13 1A D3 6A
0318 : 32 55 02 1B EB 22 59 02
0320 : C3 A0 02 2A 59 02 FB 1B
0328 : 1B C3 0E 03 00 00 00 00
0330 : CD 70 00 47 3A 5B 02 B8
0338 : D2 90 00 CD 60 02 B8 DA
0340 : 5A 03 2A 59 02 3A A2 01
0348 : BE C2 08 03 23 3A A3 01
0350 : BE C2 08 03 C3 A0 02 00
0358 : 00 00 2A 59 02 3A 22 01
0360 : BE C2 23 03 23 3A 23 01
0368 : BE 2B C2 23 03 C3 A0 02
0370 : CD 70 00 47 3A 5B 02 B8
0378 : D2 90 00 CD 60 02 B8 DA
0380 : 97 03 2A 59 02 3A A8 01
0388 : BE C2 23 03 23 3A A9 01
0390 : BE C2 23 03 C3 A0 02 2A
0398 : 59 02 3A 4C 02 BE C2 08
03A0 : 03 23 3A 4D 02 BE 2B C2
03A8 : 08 03 C3 A0 02 00 41 00
03B0 : 3A 54 02 FE 00 C2 C0 03
03B8 : 3A 55 02 FE 00 CA 80 02
03C0 : 3A 54 02 07 DA 08 03 C3
03C8 : 23 03 00 00 00 00 00 00
03D0 : 3E 00 D3 69 D3 6A 3E 20
03D8 : 32 4B 00 3A 4E 00 FE 02
03E0 : C2 DB 03 3D 32 4E 00 3A
03E8 : 4B 00 3D 32 4B 00 FE 00
03F0 : C2 DB 03 C3 80 02 00 00
03F8 : 00 00 00 00 00 00 00 00
0400 : 31 FF 00 CD 70 00 DB 69
0408 : 2F C6 04 32 51 02 DB 6B
0410 : 32 50 02 C3 00 10 41 00
0418 : 41 00 41 00 41 00 41 00
0420 : 41
DØNE

```

```

0210 : 7F 15 7F 17 7F 19 7F 1B
0218 : 7F 1C 7F 1E 7F 1F 7F 20
0220 : 7F 21 7F 22 7F 23 7F 24
0228 : 7F 25 7F 26 7F 27 7F 28
0230 : 7F 29 7F 2A 7F 2B 7F 2C
0238 : 7F 2D 7F 2E 7F 2F 7F 30
0240 : 7F 31 7F 32 7F 33 7F 34
0248 : 7F 35 7F 36 7F 37 00 00
0250 : E3 E3 E3 BA 00 00 00 A6
0258 : 01 A6 01 4D 60 BA 00 00
0260 : 3A 5D 02 47 3A 53 02 4F
0268 : 32 5D 02 90 E6 0F 07 00
0270 : 00 00 47 79 90 47 3A 5C
0278 : 02 C9 00 00 00 00 00 00
0280 : 3E 00 D3 69 D3 6A 32 54
0288 : 02 32 55 02 3A 51 02 32
0290 : 52 02 2A 57 02 22 59 02
0298 : 3E C9 32 4D 00 00 00 00
02A0 : 3A 4E 00 FE 02 C2 A0 02
02A8 : 3D 32 4E 00 3A 4D 00 3D
02B0 : FE 00 C2 B7 02 3E 65 32
02B8 : 4D 00 FE 01 C2 D0 02 3A
02C0 : 52 02 47 3A 51 02 32 52
02C8 : 02 B8 CA D0 03 00 00 00
02D0 : DB 69 2F C6 03 32 51 02
02D8 : 47 2A 59 02 29 29 29 29
02E0 : 3E 1A 94 00 00 00 4F 78
02E8 : 91 47 DB 6B 32 50 02 90
02F0 : CA B0 03 DA 30 03 C3 70
02F8 : 03 00 00 00 00 00 00 00
0300 : 00 00 00 00 00 00 00 00
0308 : 2A 59 02 EB 13 13 1A D3
0310 : 69 32 54 02 13 1A D3 6A
0318 : 32 55 02 1B EB 22 59 02
0320 : C3 A0 02 2A 59 02 FB 1B

```

Figure B-6. Program Printout (Sheet 2)

In summary, FE B2 says go CW at a speed of 6006 pps. If the number were 7E B2, which is in memory locations 01E2 and 01E3, the speed would be the same but the direction would be reversed. That is, the circled values in Figure B-6 are values stored at the indicated addresses in memory and when the program says output the value in one of these addresses the value stored (1111 1110 1011 0010 or 0111 1110 1011 0010) is delivered by the CPU to the speed control circuit which is located on the interface board.

Comparing FE B2 with 7E B2

F = 1111

7 = 0111

The left digit is for directional control and the adjacent bit is "go". If it is 0, the unit will stop, i.e., either 1011 or 0011 will result in stop.

Software - Software is the list of instructions which tells the computer what to do. To prepare software it is a usual practice to first prepare a flow chart which pictorially defines the logic problem. The flow chart for the flap drive system is shown in Figure B-7. The computer is programmed using assembly language. A standard set of instructions called the instruction set provides the codes for programming. The Altair 8800 set was shown previously in Figure B-2. Binary numbers are difficult to work with so the computer is arranged to accept hexadecimal numbers. Using the flow chart and the instruction set the programmer develops an instruction arrangement which will cause the computer to handle the data in accordance with the logic of the flow chart. The program for the Flap Drive System is shown in Figure B-8. The computer reads this program and stores in memory the instructions it needs to accomplish the instructions.

For the Flap Drive System the information stored in memory was shown previously in Figure B-5. The computer stores the data in binary form but when it is instructed to display the data stored it transforms the binary data to hexadecimal form as shown in Figure B-6.

BEST AVAILABLE COPY

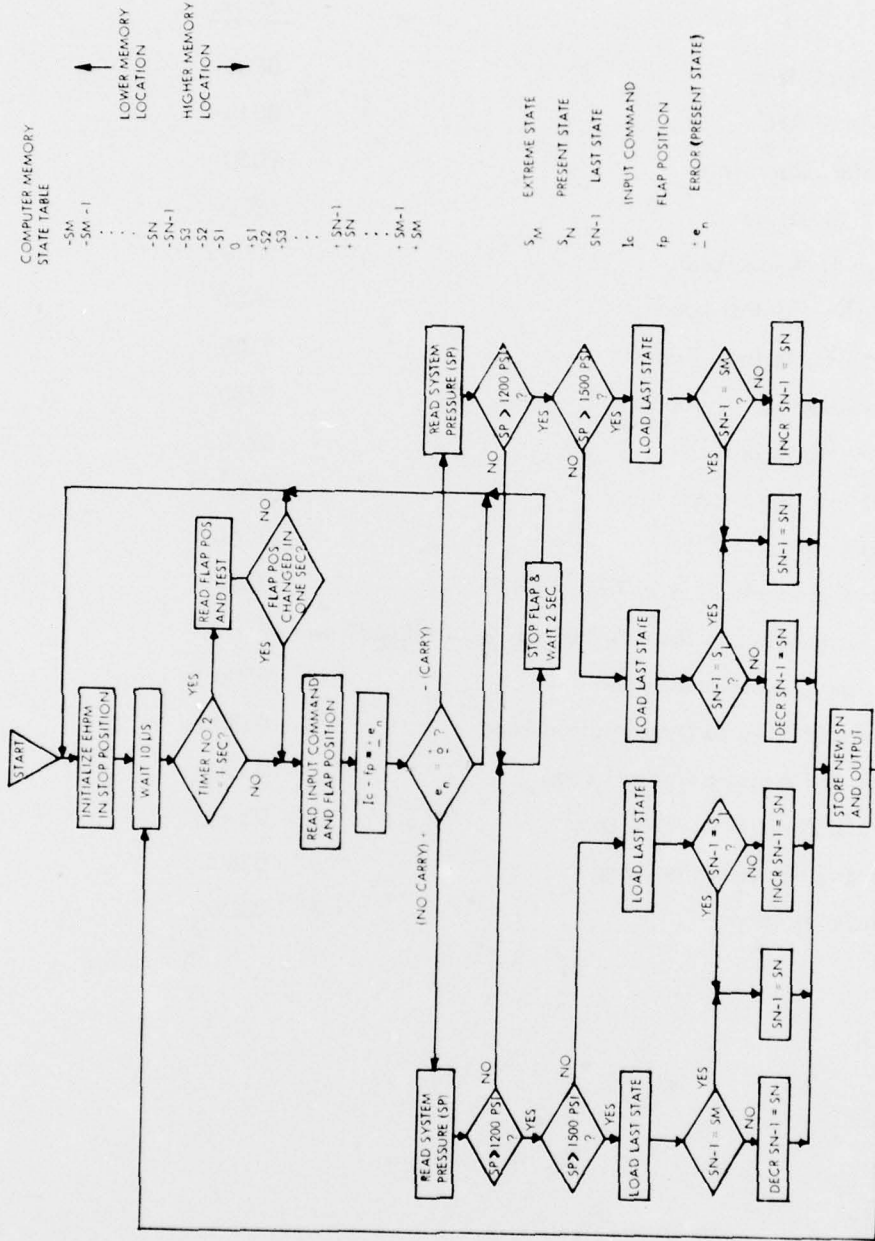

Figure B-7 Iron Bird Flap Control Flow Chart

Index to Flap Drive System Programs of Figure B-8

	<u>Address</u>
Real Time Clock Trap	0000
Initialization of RTC	0040
Clock Counter Subroutine	0050
ADC Input Subroutine	0070
Low Pressure Time-out Loop	0090
Solenoid Valve Control Loop	00D0
Acceleration Table (non linear)	0100
Memory Location for Variables	0250
Pressure Loop Time-out	0260
Startup and Initialization	0280
Clock Wait Cycle	02A0
Clock Wait Cycle and Flap in Transit Test	02B7
Calculate Error Between Input & Position & Add Lead Term	02D0
Zero Error and Deceleration Loop	0308
Minus Error and Pressure Deceleration Loop	0330
Minus Error and Pressure Control Loop	035D
Plus Error and Pressure Control Loop	0370
Zero Error and Deceleration Loop	03B0
Restart Time-out Loop	03D0

ACCELERATION TABLE (NON LINEAR)		10,000 PPS		DATA	
MN55M	DATA	FF	FE	FF	FE
0100		10,000	8,400	0140	
0101		9,950	8,310	0141	
0102		9,900	8,230	0142	
0103		9,850	8,140	0143	
0104		9,800	8,070	0144	
0105		9,750	7,975	0145	
0106		9,700	7,880	0146	
0107		9,650	7,780	0147	
0108		9,600	7,670	0148	
0109		9,550	7,590	0149	
010A		9,500	7,500	0150	
010B		9,450	7,400	0151	
010C		9,400	7,300	0152	
010D		9,350	7,200	0153	
010E		9,300	7,100	0154	
0110		9,250	7,000	0155	
0111		9,200	6,900	0156	
0112		9,150	6,800	0157	
0113		9,100	6,700	0158	
0114		9,050	6,600	0159	
0115		9,000	6,500	0160	
0116		8,950	6,400	0161	
0117		8,900	6,300	0162	
0118		8,850	6,200	0163	
011A		8,800	6,100	0164	
011B		8,750	6,000	0165	
011C		8,700	5,900	0166	
011D		8,650	5,800	0167	
011E		8,600	5,700	0168	
0120		8,550	5,600	0169	
0121		8,500	5,500	0170	
0122		8,450	5,400	0171	
0123		8,400	5,300	0172	
0124		8,350	5,200	0173	
0125		8,300	5,100	0174	
0126		8,250	5,000	0175	
0127		8,200	4,900	0176	
0128		8,150	4,800	0177	
0129		8,100	4,700	0178	
012A		8,050	4,600	0179	
012B		8,000	4,500	0180	
012C		7,950	4,400	0181	
012D		7,900	4,300	0182	
012E		7,850	4,200	0183	
0130		7,800	4,100	0184	
0131		7,750	4,000	0185	
0132		7,700	3,900	0186	
0133		7,650	3,800	0187	
0134		7,600	3,700	0188	
0135		7,550	3,600	0189	
0136		7,500	3,500	0190	
0137		7,450	3,400	0191	
0138		7,400	3,300	0192	
0139		7,350	3,200	0193	
013A		7,300	3,100	0194	
013B		7,250	3,000	0195	
013C		7,200	2,900	0196	
013D		7,150	2,800	0197	
013E		7,100	2,700	0198	
013F		7,050	2,600	0199	
				019A	
				019B	
				019C	
				019D	
				019E	
				019F	
				01A0	
				01A1	
				01A2	
				01A3	
				01A4	
				01A5	
				01A6	
				01A7	
				01A8	
				01A9	
				01AB	
				01AC	
				01AD	
				01AE	
				01AF	
				01B0	
				01B1	
				01B2	
				01B3	
				01B4	
				01B5	
				01B6	
				01B7	
				01B8	
				01B9	
				01BA	
				01BB	
				01BC	
				01BD	
				01BE	
				01BF	
				01C0	
				01C1	
				01C2	
				01C3	
				01C4	
				01C5	
				01C6	
				01C7	
				01C8	
				01C9	
				01CA	
				01CB	
				01CC	
				01CD	
				01CE	
				01CF	
				01D0	
				01D1	
				01D2	
				01D3	
				01D4	
				01D5	
				01D6	
				01D7	
				01D8	
				01D9	
				01DA	
				01DB	
				01DC	
				01DD	
				01DE	
				01DF	
				01E0	
				01E1	
				01E2	
				01E3	
				01E4	
				01E5	
				01E6	
				01E7	
				01E8	
				01E9	
				01EA	
				01EB	
				01EC	
				01ED	
				01EE	
				01EF	
				01F0	
				01F1	
				01F2	
				01F3	
				01F4	
				01F5	
				01F6	
				01F7	
				01F8	
				01F9	
				01FA	
				01FB	
				01FC	
				01FD	
				01FE	
				01FF	
				0200	
				0201	
				0202	

Figure B-8. C-5 Iron Bird Flap Drive Program (Sheet 2)

37F	JC	DA	YES GO TO HOLD	00	CA	YES? LOOP TO START
380	TST LO	03		00	CA	
381	LHLD	2A	NO PS IS BELOW 1500	02	02	
382	PTR	59		3E	02	ERROR NOT ZERO
383	LDA	02		80	03	SET VALVE BIT
384	LDA	3A		D3	03	OPEN VALVE
385	LDA	AC		6F	3A	FETCH LAST TABLE ENTRY
386	LDA	01		54	54	
387	CMPL	RE	FIRST WORD ZERO?	07	07	SHIFT MSB TO CARRY
388	JNC	C2	NO-GO TO DECR	DA	DA	MSB SET? LOOP TO DECR
389	DECR	23		23	23	
38A	INXH	23	INCREMENT PTR	03	03	MSB NOT SET, LOOP TO INCR
38B	LDA	3A		C3	C3	
38C	LDA	AD		08	08	
38D	MVA	AD		00	00	
38E	CMPL	BE	2ND WORD ZERO?	3E	3E	LOAD A REGISTER WITH ZERO
390	JNZ	C2	NO-GO TO DECR	00	00	OUTPUT PM 1
391	DECR	23		69	D3	OUTPUT PM 2
392	DECR	23		6A	3E	INITIALIZE COUNTER
393	JMD	C3	YES - JMP TO WAIT	20	32	SAVE A5 CTR NO. 4
394	WAIT	AO		48	00	
395	WAIT	AO		00	00	FETCH CTR NO. 1
396	WAIT	AO		3A	3A	
397	LHLD	2A	FETCH POINTER	4E	4E	
398	PTR	59		FE	FE	TEST CTR NO. 1
399	LDA	02		02	02	CTR NO. 1=2
39A	LDA	3A	LOWEST VALUE IN TABLE	C2	C2	NO? LOOP TO AGAIN
39B	PLSSM	4C		0B	0B	
39C	PLSSM	02		3D	3D	FORCE COUNTER DOWN 1 COUNT
39D	CMPL	BE	IS PTR @ LOWEST VALUE?	4E	4E	SAVE NEW COUNT
39E	JNZ	C2	NO? GO TO INCR	00	00	FETCH CTR NO. 4
39F	JNZ	08		3A	3A	
3A0	INCR	08		48	48	
3A1	INXH	23	YES? FETCH NEXT WORD	00	00	
3A2	LDH	3A	LOWEST VALUE + 1	3A	3A	
3A3	PLSSM	4D		4E	4E	
3A4	PLSSM	02		00	00	
3A5	CMPL	BE	IS PTR @ LOWEST VALUE + 1?	FE	FE	TEST CTR NO. 1
3A6	DCXH	2B	RESET PTR TO LO VALUE	02	02	CTR NO. 1=2
3A7	JNC	C2	NO? GO TO INCR	C2	C2	NO? LOOP TO AGAIN
3A8	JNC	08		0B	0B	
3A9	JMP	03	YES - GO TO WAIT	3D	3D	FORCE COUNTER DOWN 1 COUNT
3AA	JMP	C3		4E	4E	SAVE NEW COUNT
3AB	WAIT	AO		00	00	FETCH CTR NO. 4
3AC	WAIT	AO		3A	3A	
3AD	WAIT	AO		48	48	
3AE	WAIT	AO		00	00	DECREMENT CTR NO. 4
3AF	WAIT	AO		32	32	SAVE NEW COUNT

380	E ZRO:	LDA	3A	FETCH LAST TABLE ENTRY
381	LSTE1	LSTE1	54	
382	CPI	CPI	FE	IS ENTRY ZERO?
383	CPI	FE	FE	
384	JNZ	JNZ	00	NO? SET VALVE OPEN AND TEST MSB
385	JNZ	C2	C2	NO? SET VALVE OPEN AND TEST MSB
386	CO	CO	03	
387	CO	03	03	
388	LDA	3A	3A	YES? FETCH OTHER 1/2 OF WORD
389	LSTE 2	LSTE 2	55	
38A	CPI	CPI	02	
38B	CPI	FE	FE	IS OTHER HALF ZERO?

380	RZC:	JZ		
38D	RZC:	JZ		
38E	NON ZRO:	MVIA		
38F	NON ZRO:	MVIA		
390	NON ZRO:	MVIA		
391	NON ZRO:	MVIA		
392	NON ZRO:	MVIA		
393	NON ZRO:	MVIA		
394	NON ZRO:	MVIA		
395	NON ZRO:	MVIA		
396	NON ZRO:	MVIA		
397	NON ZRO:	MVIA		
398	NON ZRO:	MVIA		
399	NON ZRO:	MVIA		
39A	NON ZRO:	MVIA		
39B	NON ZRO:	MVIA		
39C	NON ZRO:	MVIA		
39D	NON ZRO:	MVIA		
39E	NON ZRO:	MVIA		
39F	NON ZRO:	MVIA		
3A0	NON ZRO:	MVIA		
3A1	NON ZRO:	MVIA		
3A2	NON ZRO:	MVIA		
3A3	NON ZRO:	MVIA		
3A4	NON ZRO:	MVIA		
3A5	NON ZRO:	MVIA		
3A6	NON ZRO:	MVIA		
3A7	NON ZRO:	MVIA		
3A8	NON ZRO:	MVIA		
3A9	NON ZRO:	MVIA		
3AA	NON ZRO:	MVIA		
3AB	NON ZRO:	MVIA		
3AC	NON ZRO:	MVIA		
3AD	NON ZRO:	MVIA		
3AE	NON ZRO:	MVIA		
3AF	NON ZRO:	MVIA		

380	RESTART TIME OUT LOOP	3D0	TIMEOUT:	3E	LOAD A REGISTER WITH ZERO
381	TIMEOUT:	3D1	MVIA	00	OUTPUT PM 1
382	TIMEOUT:	3D2	OUT	00	OUTPUT PM 2
383	TIMEOUT:	3D3	PM 1	69	INITIALIZE COUNTER
384	TIMEOUT:	3D4	OUT	D3	SAVE A5 CTR NO. 4
385	TIMEOUT:	3D5	PM 2	6A	
386	TIMEOUT:	3D6	MVIA	3E	
387	TIMEOUT:	3D7	STA	20	
388	TIMEOUT:	3D8	CTR 4	32	
389	TIMEOUT:	3D9	CTR 4	48	
390	TIMEOUT:	3DA	LDA	00	
391	TIMEOUT:	3DB	CTR 1	3A	
392	TIMEOUT:	3DC	CTR 1	4E	
393	TIMEOUT:	3DD	CPI	00	
394	TIMEOUT:	3DE	JNZ	FE	
395	TIMEOUT:	3DF	AGAIN	02	
396	TIMEOUT:	3E0	DCRA	C2	
397	TIMEOUT:	3E1	STA	0B	
398	TIMEOUT:	3E2	DCRA	3D	
399	TIMEOUT:	3E3	STA	4E	
39A	TIMEOUT:	3E4	LDA	00	
39B	TIMEOUT:	3E5	DCRA	3A	
39C	TIMEOUT:	3E6	STA	48	
39D	TIMEOUT:	3E7	LDA	00	
39E	TIMEOUT:	3E8	DCRA	3A	
39F	TIMEOUT:	3E9	STA	48	
390	TIMEOUT:	3EA	DCRA	00	
391	TIMEOUT:	3EB	STA	32	
392	TIMEOUT:	3EC	CPI	48	
393	TIMEOUT:	3ED	JNZ	FE	
394	TIMEOUT:	3EE	AGAIN	02	
395	TIMEOUT:	3EF	JNZ	00	
396	TIMEOUT:	3F0	AGAIN	C2	
397	TIMEOUT:	3F1	JMP	0B	
398	TIMEOUT:	3F2	START	03	
399	TIMEOUT:	3F3	JMP	C3	
39A	TIMEOUT:	3F4	START	80	
39B	TIMEOUT:	3F5	START	02	

Figure B-8. C-5 Iron Bird Flap Drive Program (Sheet 5)

REFERENCES

1. Guide to Performance Specifications of EHSM's, Hydraulics and Pneumatics Magazine, Part 1, March 1972, Part 2, June 1972.
2. Stepper Motors, Electromechanical Design Magazine, 1973/74 System Designers Handbook.
3. Fluid Power Control, Blackburn, et al, The M.I.T. Press, The Massachusetts Institute of Technology, Cambridge, Massachusetts.
4. Design of Machine Elements, M. F. Spotts, Prentice - Hall, Inc., 70 Fifth Avenue, New York, New York.
5. Closed Loop and Speed Control of Step Motors, Kno, B. C. and Singh, G., 3rd Annual Symposium on Incremental Motor Control Systems and Devices, May 1974 at Urbana Champaign, Illinois.
6. Wrist Motion, Thrust, Steps are Choices in New Fluid Cylinders, Product Engineering, December, 1972.