

AD-A042 384

BOEING COMMERCIAL AIRPLANE CO SEATTLE WASH
ADHESIVE BONDED AEROSPACE STRUCTURES STANDARDIZED REPAIR HANDBO--ETC(U)
DEC 76 J E MCCARTY, R E HORTON, M C LOCKE F33615-73-C-5171
AFML-TR-76-201 NL

UNCLASSIFIED

| OF |
AD
A042384

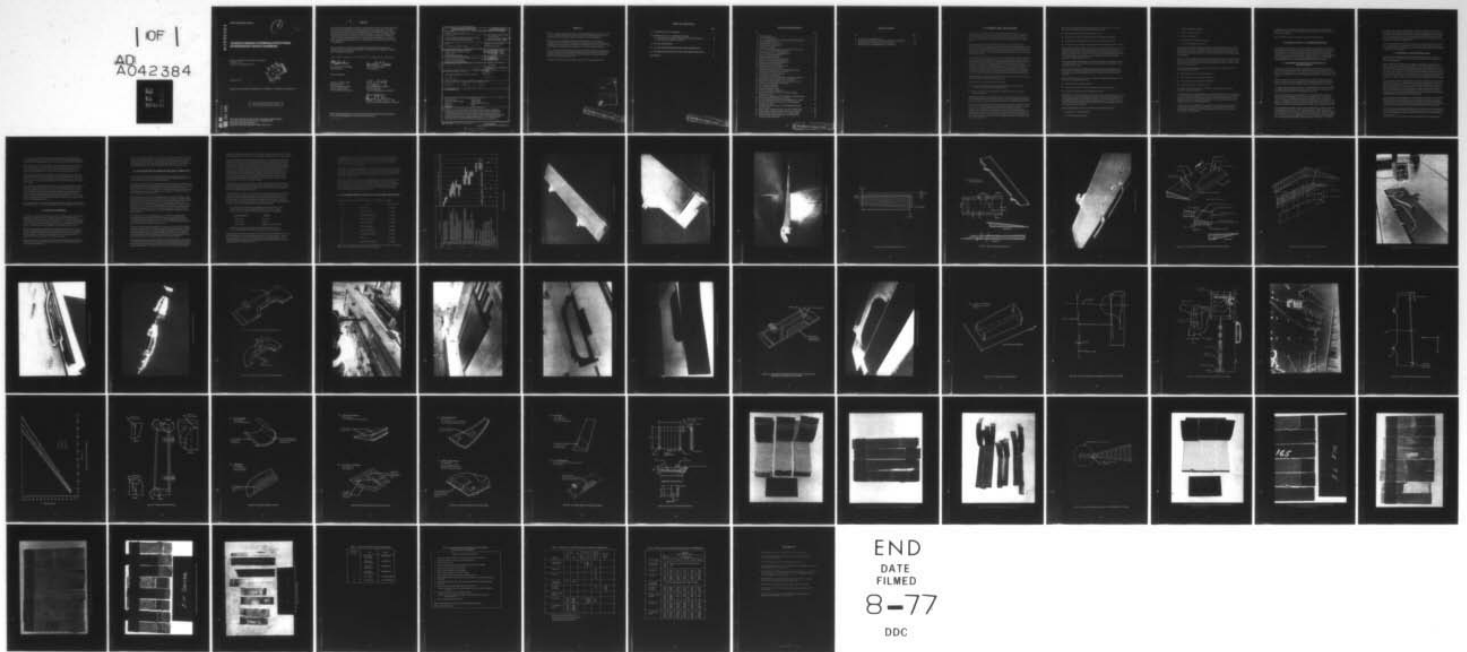

END
DATE
FILMED
8-77
DDC

ADA 042384

AFML-TR-76-201/AFFDL-TR-76-131

4

J

ADHESIVE BONDED AEROSPACE STRUCTURES STANDARDIZED REPAIR HANDBOOK

BOEING COMMERCIAL AIRPLANE COMPANY
P.O. BOX 3707
SEATTLE, WASHINGTON 98124

DDC
JUL 11 1977
C

December 1976

PHASE IV FINAL REPORT FOR PERIOD 1 OCTOBER 1975 THROUGH 31 MARCH 1976

Approved for public release; distribution unlimited

AU NO. _____
DDC FILE COPY

AIR FORCE MATERIALS AND FLIGHT DYNAMICS LABORATORIES
AIR FORCE WRIGHT AERONAUTICAL LABORATORIES
AIR FORCE SYSTEMS COMMAND
WRIGHT-PATTERSON AIR FORCE BASE, OHIO 45433

NOTICE

When Government drawings, specifications, or other data are used for any purpose other than in connection with a definitely related Government procurement operation, the United States Government thereby incurs no responsibility nor any obligation whatsoever; and the fact that the Government may have formulated, furnished, or in any way supplied the said drawings, specifications, or other data, is not to be regarded by implication or otherwise as in any manner licensing the holder or any other person or corporation, or conveying any rights or permission to manufacture, use, or sell any patented invention that may in any way be related thereto.

This report has been reviewed by the Information Office (IO) and is releasable to the National Technical Information Service (NTIS). At NTIS, it will be available to the general public, including foreign nations.

This technical report has been reviewed and is approved for publication.

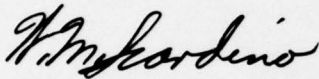

W. M. Scardino (AFML/MXE)
Project Engineer



H. Croop (AFFDL/FBS)
Project Engineer

For the Commander

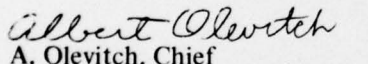

A. Olevitch, Chief
Materials Engineering Branch
Systems Support Division
Air Force Materials Laboratory

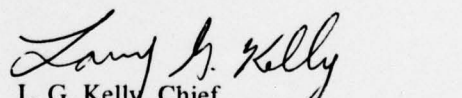

L. G. Kelly, Chief
Structural Development Branch
Structures Division
Air Force Flight Dynamics Laboratory

FOR THE COMMANDER

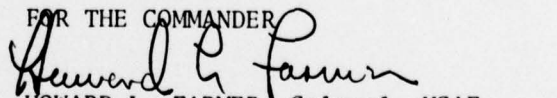

HOWARD L. FARMER, Colonel, USAF
Chief, Structural Mechanics Division

Copies of this report should not be returned unless return is required by security considerations, contractual obligations, or notice on a specific document.

SECURITY CLASSIFICATION OF THIS PAGE (When Data Entered)

| REPORT DOCUMENTATION PAGE | | READ INSTRUCTIONS BEFORE COMPLETING FORM |
|--|-----------------------|---|
| 1. REPORT NUMBER AFML-TR-76-201/AFFDL-TR-76-131 | 2. GOVT ACCESSION NO. | 3. RECIPIENT'S CATALOG NUMBER |
| 4. TITLE (and Subtitle) ADHESIVE BONDED AEROSPACE STRUCTURES STANDARDIZED REPAIR HANDBOOK | | 5. TYPE OF REPORT & PERIOD COVERED Phase IV Report 1 Oct. 1975 through 31 March 1976 |
| 7. AUTHOR(s) J. E. McCarty, R. E. Horton, et al. M. C. Lockes M. L. Satterthwait B. D. Parashar | | 6. PERFORMING ORG. REPORT NUMBER |
| 9. PERFORMING ORGANIZATION NAME AND ADDRESS Boeing Commercial Airplane Company P.O. Box 3707 Seattle, Washington 98124 | | 8. CONTRACT OR GRANT NUMBER(s) F33615-73-C-5171 |
| 11. CONTROLLING OFFICE NAME AND ADDRESS Air Force Materials and Flight Dynamics Laboratory Air Force Systems Command Wright-Patterson AFB, Ohio 45433 | | 10. PROGRAM ELEMENT, PROJECT, TASK AREA & WORK UNIT NUMBERS Project 73810677 (AFML) Project 13680213 (AFFDL) |
| 14. MONITORING AGENCY NAME & ADDRESS (if different from Controlling Office) Final rept. 1 Oct 75 - 31 Mar 76, on Phase 4 | | 12. REPORT DATE December 1976 |
| 16. DISTRIBUTION STATEMENT (of this Report) Approved for public release; distribution unlimited. 12 62pp. | | 13. NUMBER OF PAGES 17 46, 42 |
| 17. DISTRIBUTION STATEMENT (of the abstract entered in Block 20, if different from Report) 18 AFML, AFFDL | | 15. SECURITY CLASS. (of this report) Unclassified |
| 18. SUPPLEMENTARY NOTES | | 15a. DECLASSIFICATION/DOWNGRADING SCHEDULE 4 |
| 19. KEY WORDS (Continue on reverse side if necessary and identify by block number) Adhesive bonding Metal bonding Standardized repair handbook Aircraft repair Sandwich Bonded aerospace structure Honeycomb Repair Handbook | | |
| 20. ABSTRACT (Continue on reverse side if necessary and identify by block number) This report covers the fourth phase of a five-phase program to develop a standardized handbook for the repair of bonded aircraft structure. Tasks include the standardization of small repairs that are now covered by the various aircraft technical orders as well as general instructions for large repair work, including component rebuilding. Work completed in Phase IV included the repair and flight simulation test of an F-111 outboard spoiler. This work will serve as a base for procedures to be designated in the handbook. | | |

390145

LB

PREFACE

This technical report summarizes the work accomplished during Phase IV of contract F33615-73-C-5171, "Adhesive Bonded Aerospace Structures Standardized Repair Handbook," by the Boeing Commercial Airplane Company, P.O. Box 3707, Seattle, Washington.

The work was accomplished under the joint sponsorship of the Air Force Materials Laboratory (Project 7381/Task 06) and the Air Force Flight Dynamics Laboratory (Project 1368/Task 02). Mr. W. Scardino, AFML/MXE of the Materials Laboratory, and Mr. H. Croop, AFFDL/FBS of the Flight Dynamics Laboratory, are the Air Force project engineers.

Mr. J. E. McCarty was the Boeing program manager, and Mr. R. E. Horton was the principal investigator. Other Boeing personnel who made technical contributions to the program and their areas of activity are as follows: M. C. Locke, Materials; M. L. Satterthwait, Manufacturing; and B. D. Parashar, Quality Control.

This work was performed in the period from 1 October 1975 through 31 March 1976.

| | |
|---------------------------------|---|
| ACCESSION NO. | |
| AFIS | White Section <input checked="" type="checkbox"/> |
| 1: C | Buff Section <input type="checkbox"/> |
| UNANNOUNCED | <input type="checkbox"/> |
| JUSTIFICATION..... | |
| SY | |
| DISTRIBUTION/AVAILABILITY CODES | |
| Dist. | AVAIL. and/or SPECIAL |
| AA | |

PRECEDING PAGE BLANK NOT FILMED

TABLE OF CONTENTS

| | Page |
|---|------|
| 1.0 INTRODUCTION AND SUMMARY | 1 |
| 2.0 REPAIR OF THE F-111 OUTBOARD SPOILER | 4 |
| 2.1 Description of the Spoiler Construction and the Repair Design | 4 |
| 2.2 Description of the Repair Procedures | 5 |
| 3.0 TEST OF THE SPOILER | 6 |
| 4.0 TEST OF SPECIMENS FROM THE REPAIRED COMPONENTS | 7 |
| 5.0 HANDBOOK PREPARATION STATUS AND COMPLETION PLANS | 9 |
| REFERENCES | 55 |

PRECEDING PAGE BLANK NOT FILMED

LIST OF ILLUSTRATIONS

| No. | | Page |
|-----|--|------|
| 1 | Program Schedule | 10 |
| 2 | F-111 Outboard Spoiler | 11 |
| 3 | F-111 Outboard Spoiler, Closeup of End and Fitting Construction | 12 |
| 4 | Outboard Spoiler, End View | 13 |
| 5 | Spoiler Planform Geometry (ref. 1) | 14 |
| 6 | Details of Spoiler Construction | 15 |
| 7 | Damaged F-111 Spoiler | 16 |
| 8 | F-111 Outboard Spoiler Upper Surface and Repair Cross Section | 17 |
| 9 | View of the Lower Surface Repair Details | 18 |
| 10 | Ultrasonic Inspection of the Damaged Spoiler | 19 |
| 11 | Removal of the Damaged Material | 20 |
| 12 | High-Speed Router Assembly | 21 |
| 13 | Removal of Skin Strip After Router Casts | 22 |
| 14 | Removal of Core Strip From the Repair Area | 22 |
| 15 | Machining the Sheet Metal Repair Details | 23 |
| 16 | Machining the Core Repair Detail | 24 |
| 17 | Details Assembled for the First-Stage Cure | 25 |
| 18 | Flush Patch on the Upper Surface | 26 |
| 19 | Areas Masked to Prevent Acid Contamination During Surface Preparation for Bonding Closure Sicon Patch | 27 |
| 20 | Nonflush Patch on the Lower Surface | 28 |
| 21 | F-111 Spoiler Load Distribution | 29 |
| 22 | Position of the Actuator Linkage With the Spoiler Extended 20° | 30 |
| 23 | Sketch Showing the Test Setup for the F-111 Spoiler | 31 |
| 24 | Repaired F-111 Spoiler Mounted on the Strongback For Test | 32 |
| 25 | Location of Electrical Deflection Indicators | 33 |
| 26 | Plot of Deflection Readings | 34 |
| 27 | Areas of Bond Delamination | 35 |
| 28 | Component Specimen Testing | 36 |
| 29 | Details of the Wedge Test Specimen | 40 |
| 30 | Honeycomb Peel Tests From the C-141 Wing L.E. Repair Showing Core Failure | 41 |
| 31 | Cohesive Failure Surfaces of the C-141 Wing L.E. Wedge Specimens | 42 |
| 32 | Salt Spray Exposed Peel Specimens After Test | 43 |
| 33 | Location of Bondline Porosity in the T-38 Stabilator T.E. Repair | 44 |
| 34 | Honeycomb Peel Specimens From the A-6 Fin Panel Repair Showing Core Failure | 45 |
| 35 | Lap Shear Specimens From the A-6 Fin Panel Repair Showing Cohesive Failure | 46 |
| 36 | Failure Surface of Wedge Specimens From the T-38 Door Repair | 47 |
| 37 | Failure Surfaces of Wedge Specimens From the F-111 Spoiler | 48 |
| 38 | Failed Lap Shear Specimens From the F-111 Spoiler Repair | 49 |
| 39 | Failed Lap Shear and Wedge Specimens Cut From the F-111 Titanium Fuselage Panel Repair | 50 |

LIST OF TABLES

| No. | | Page |
|-----|--|------|
| 1 | Identification of Spoiler Materials | 51 |
| 2 | Procedure Used to Prepare the Aluminum Skin Surfaces for Bonding | 52 |
| 3 | Results of Tests From Repaired Areas of Components | 53 |
| 4 | Wedge Test Data From Repaired Areas of Components | 54 |

1.0 INTRODUCTION AND SUMMARY

The use of adhesive bonding in aircraft structures has expanded greatly in recent years, broadening from use in secondary structures to considerable use in primary applications. Because adhesive bonding is now being used extensively by all manufacturers, repairs involving bonded components are an important part of the military maintenance depot activity.

The rapid expansion of this technology has created many new repair requirements. Important to this repair technology is the need for improvement and standardization of the repair procedures and providing instruction for large repair and rebuilding as well as for the small patches. Procedures must be kept up-to-date. If the repairs are to be accomplished efficiently, procedures must be consistent for repairing similar types of structure on various manufacturers' aircraft.

At the present time, procedural coverage for adhesive bonded structure repair meeting these requirements is lacking. Instructions for large repairs are quite limited. Repair documents, technical orders (T.O.), typically cover only small repairs and are developed by each manufacturer using his own preferred manufacturing methods and materials. This creates difficulties, especially since an individual depot may repair several different models or types of aircraft. A mechanic may repair similar damage on several types of aircraft and be instructed to use different materials and methods on each. In addition to the procedural confusion, the situation results in an unnecessarily large material inventory. Keeping the many T.O.'s up-to-date with current methods and materials development is also difficult.

This program has been undertaken to remedy these situations and to increase the efficiency of repairing bonded components on military aircraft.

The major goals of this program are defined as follows:

- Develop a standardized material list and standardized repair and inspection procedures for small area repairs on military aircraft
- Provide a repair guide for major repairs or rebuilding of large areas of bonded aircraft components

This five-phase program is to be performed over a 3-year period. The tasks and program schedule defined for each phase are shown in figure 1. The first four phases of this program have been completed. This document reports on the work accomplished during Phase IV.

Phase I was accomplished during the initial 6 months of the program, starting on 1 October 1973. The work consisted primarily of information gathering and cataloging. A comprehensive review was made of pertinent Air Force T.O.'s. Repair geometries were cataloged, and material lists were extracted for various service and cure temperatures. In addition, visits were made to several military and commercial repair depots and airframe manufacturers' facilities. Insight was obtained into such areas as types of damage incurred, current repair materials and procedures used, availability of facilities and equipment, and level of personnel skills.

Phase II was accomplished over the 9-month period from 1 April 1974 to 31 December 1974. The tasks performed in Phase II consisted of the following:

- Definition of the handbook outline and repair criteria
- Definition of the small area repair methods to be included in the handbook
- Evaluation of candidate adhesive systems and surface preparation methods
- Participation in a joint military/industry repair handbook workshop at Dayton, Ohio

Eighteen adhesive systems and approximately 16 surface preparation methods were evaluated during Phase II. With the exception of some of the new generation epoxy systems, the adhesives were largely those currently used at the repair depots and included systems curing at room temperature, 250°F, and 350°F. The surface preparation methods included solvent and acid hand cleaning and acid tank cleaning. Development work was done using a phosphoric acid hand-cleaning procedure.

Test results confirmed the superiority of the elevated temperature curing adhesives and the acid-cleaning methods. The suitability of a particular cleaning method depends greatly on the specific adhesive system.

Phase II of the program was terminated with a joint military/industry workshop held at Dayton, Ohio. The workshop afforded an opportunity to review the handbook program status and to incorporate the suggestions from aircraft manufacturers and future handbook users.

Phase III of the program began 1 January 1975 and was completed on 30 September 1975. The work was conducted in three areas:

- Repair and test of small repair specimens
- Repair and evaluation of components furnished by the Air Force and Navy
- Preparation of drafts of several of the handbook sections

Evaluation of the small repairs involved the fabrication of 30 sandwich test specimens. Two-thirds of the specimens were aluminum and one-third were titanium. Half of the specimens were damaged simulating a hole through both surfaces. These were then repaired and a comparison made between the repaired and undamaged controls. The adhesives used were those currently being used for the repair of Air Force aircraft. The specimens were tested in tension, compression, and fatigue.

Repair method demonstrations were conducted on the following components:

1. Simulated C-141 wing leading edge
2. F-111 fuselage panel (titanium)

3. T-38 main landing-gear wheel door
4. C-5A aileron trailing-edge panel
5. T-38 horizontal stabilator
6. C-141 double-contoured APU access panel
7. A-6 vertical fin (supplied by the Navy)

The simulated C-141 wing leading-edge component was fabricated during Phase II. During Phase III, a major part of the component was rebuilt. This simulated work was done at the Warner Robins, Air Logistics Center (ALC). This included removal and replacement of the outer skin and a major portion of the core. The use of three different acid cleaning methods was investigated.

Repair work was completed on the other six components listed. The F-111 titanium fuselage panel was repaired using PasaJell 107 as the surface preparation method for bonding. Surface preparation for the aluminum components was done using the phosphoric acid hand anodize method developed in Phase II.

Phase IV was completed during the period from 1 October 1975 to 31 March 1976. The work included four basic tasks:

- Repair of damage to an F-111 outboard spoiler
- Test of the spoiler with simulated critical air loads
- Test of specimens cut from repaired components
- Preparation of drafts of handbook sections

The spoiler was obtained from the Sacramento ALC. It had been in service but was replaced in a modification program.

The spoiler planform was approximately 65-in. long and tapered from 14.7-in. wide inboard to 11.7-in. wide on the outboard end. It had only minor damage when received. Additional damage was imposed on the trailing edge to require a repair that was approximately 24-in. long and 5-in. wide. The repaired area included part of the region that was reinforced to distribute load from the outboard hinge fitting.

The spoiler test was accomplished in the same manner as that done by General Dynamics to qualify the production spoiler. This was for the critical condition with the spoiler deflected 20°. Loading was to 150% of the design limit load. The test was successful with no failure in the repair area.

In addition to the repair and test of the spoiler, test coupons were cut from the spoiler and from the components repaired in Phase III. These were tested to various conditions to verify the repair adequacy.

The various Phase IV tasks are discussed in detail in the following sections.

2.0 REPAIR OF THE F-111 OUTBOARD SPOILER

During Phase III of this program, seven aircraft components were repaired to demonstrate the feasibility of procedures that will be incorporated in the handbook. Small specimens were subsequently cut from the components to evaluate the repair quality. An eighth component, an F-111 spoiler, was selected for repair during Phase IV. This provided a part where the ultimate load was quite high. In addition, the test cost was compatible with the overall program budget. The spoiler was repaired and tested as a component with simulated flight loads. It was then cut up and small specimen tests conducted.

2.1 DESCRIPTION OF THE SPOILER CONSTRUCTION AND THE REPAIR DESIGN

A photo of the spoiler is given in figure 2. This shows the underside of the component with the two attachment fittings. The forward holes are for the fixed hinge pins. The aft holes are for the actuator rods. A closeup of the end of the spoiler is shown in figure 3. The cross section of the spoiler is that of a thin wedge, shown in figure 4. It is flat on the upper surface.

The spoiler design is for the F-111 A/B model aircraft. A sketch showing the planform geometry of the spoiler is given in figure 5 (ref. 1). Details of construction are shown in figure 6 with table 1 identifying the pertinent materials, thicknesses, and core densities.

The design of the spoiler requires the ability to withstand limited time exposure to 350°F. Accordingly, high-temperature adhesives were used in construction. Those approved for repair are Aerobond 3030, AF-130, and Reliabond 398 (ref. 2).

The spoiler was obtained from the Sacramento ALC. The part had been surplused as part of a remodification program. As such, it was undamaged. Since typical damage to this type of part is in the trailing-edge, damage was inflicted in that area, as shown in figure 7. The damage was toward the outboard end of the spoiler. It included part of the skin that was padded up to distribute load from the hinge fitting (see fig. 6, table 1). The damage extended inboard approximately 24 in. and about 5 in. into the spoiler chordwise.

Sketches illustrating the repair concept are shown in figures 8 and 9. Figure 8 shows the upper surface and a repair cross section. The repair is flush on the flat upper surface. The 0.020 flush patch is spliced to the component skin with a 2.50-in. wide internal splice plate. This allows a 1.25-in. wide lap bond on each side of the splice. The lap bond width was selected to give skin splice strength greater than the strength of the 0.020 sandwich face. The typical ultimate strength of 2024-T81 aluminum is 65 ksi (ref. 3). This gave a

joint strength requirement for the 0.020 skin of 1300 lb/in. Reliabond 398 was used for the adhesive. This was tested during Phase II. The typical strength for a 1.25-in. wide lap was approximately 2000 lb/in. (ref. 4). This was adequate and provided a positive margin of safety. The material selected for the patch plates was 0.020, 2024-T3 bare aluminum. The arrowhead fitting was to be machined from 0.25, 7075-T6 bare aluminum plate. The replacement core was 4.5-1/8-10N±(5052).*

The lower skin patch shown in section A-A of figure 8 was nonflush and lapped the skin by 1.25 in. similar to the internal splice plate. A cross section of the assembled parts is given in section B-B. An 0.016 doubler was placed under the patch plate where the 0.036 padded-up area was removed (see figure 9).

2.2 DESCRIPTION OF THE REPAIR PROCEDURES

The boundary of the damage was outlined using a Harmonic Bond Tester as shown in figure 10. This gave an indication of the extent of any delamination that had progressed beyond the usual damage.

Removal of the damaged material was accomplished with a high-speed air-driven router, figure 11. The router assembly is shown in figure 12. The router was guided by use of a metal strip template. The width of the template was sized so cuts could be made on both sides. The cut on the inside of the template was made through the entire depth. The cut on the outside of the template was 1.25-in. wider to allow for lap of the internal splice strap as shown in figure 8, section A-A. After making the router cuts, the strip of skin was removed as shown in the sketch in figure 13. The core strip was removed with a sharpened putty knife, figure 14. The core residue was removed with a fine sanding disk and vacuum pickup.

After removal of the damage, the detail parts were fabricated. Machining of the sheet metal details is shown in figure 15. The replacement core is shown being machined in figure 16. Prior to machining, the honeycomb core was stabilized by bonding a layer of adhesive and nylon fabric to one surface. This surface was then vacuum chucked to the core machine bed. After machining, the core detail was placed in a degreaser to soften the adhesive. The layer of nylon fabric (peel ply) and adhesive were then carefully removed. The edge of the core piece was trimmed to fit snugly in the repair area. The metal sheet details and trailing-edge piece were preassembled to ensure proper fit.

Cure of the repair was accomplished in two cycles or stages. The initial cure cycle involved bonding the flush upper skin patch, splice strap, arrowhead section shim, and core plug (see fig. 8 and 9). Prior to bonding, the sheet metal details were prepared by phosphoric acid hand anodizing. The detail steps of this procedure are listed in table 2 (full description in ref. 4). The core was cleaned by immersion in trichloroethylene (TCE) and baked.

The bond was made using Reliabond 398 adhesive; no primer was used. This simulated the procedure used at the ALC's. AF3015 foam was used to splice the core interfaces and the core to the trailing-edge arrowhead. The assembly is shown ready for vacuum bagging and

*4.5 lb/ft³, 1/8 in. cell size, 0.001 foil thickness, nonperforated, 5052 aluminum alloy.

cure in figure 17. As shown, the spoiler is placed upside down with the flush (upper) surface placed against a flat 0.060 caul plate. The edge of the arrowhead fitting is shown extended beyond the trailing edge. This excess was removed by machining after bonding.

After assembly (fig. 17), the repair area was covered with FEP release film two layers of PVA fiberglass cloth, and a metal caul plate. This was followed by thermocouple wires and standard shop bagging materials. The cure was at 350°F for 90 min with 35-psi pressure. The flush upper surface is shown after curing and trimming in figure 18.

Following the first-stage cure, the bonded area was visually inspected to ensure that the details had held position and that the adhesive foam had expanded properly and was free of voids. The core surface was then sanded flush with the outer skin surface. The sanding debris was removed by vacuum, and the surface of the core was wiped with methylethylketone (MEK).

The next step was to prepare the metal surfaces for bonding the nonflush lower skin patch plate and the doubler shown in figure 10. The areas surrounding the area to be cleaned were masked with aluminum foil tape as shown in figure 19. The bond surface on the spoiler, the doubler, and the patch plate were then phosphoric acid anodized by the procedure noted previously in table 2. Following the surface preparation, the masking materials were removed and the doubler and patch plate taped in position. The assembly was then bagged and cured at 350°F for 60 min under 35-psi pressure. The repair is shown after cure and debagging in figure 20.

The completed repair was inspected using through-transmission ultrasonics and a portable Harmonic Bond Tester. The results were satisfactory; no voids or delaminations were found.

3.0 TEST OF THE SPOILER

The spoiler test condition was the same as the critical condition used by General Dynamics to qualify the component for service. This was test condition SP-2 with the spoiler deflected 20° and the center of pressure at 50% chord (ref. 5). The design limit load (DLL) was 3.7-psi pressure inboard and 5.9-psi outboard (ref. 6). The ultimate load distribution, which is 150% of the DLL is shown in figure 21. This gave a total ultimate load of 6157.6 pounds. The position of the actuator linkage for test is shown in figure 22 (ref. 7).

The spoiler was mounted on a strongback for test as shown in figures 23 and 24 (ref. 8). Two rows of eight loading pads were used to distribute the load. The load was applied through a whiffle-tree arrangement with a hydraulic actuator coupled to a load cell. The load was applied in 20% DLL increments to 100% DLL. The increments were then decreased to 10% DLL until ultimate (150% DLL) was reached.

Deflection readings were taken at three locations along the trailing edge. Locations of the electrical deflection indicators (EDI) are shown in figure 25. The deflections that were recorded are plotted in figure 26.

There was no indication during the test of any failure. A posttest visual inspection, however, revealed bond separations in three areas. These were at the specimen's corners outside the repaired area as shown in figure 27. Subsequently, inspections were made using water-coupled through-transmission ultrasonics and a Harmonic Bond Tester. These verified the three delaminated areas. There was no indication of any failure in the repaired area.

4.0 TEST OF SPECIMENS FROM THE REPAIRED COMPONENTS

After the components had been repaired and nondestructively inspected, specimens were cut from the repaired areas to assess the quality of the bonds that had been obtained. The location and types of specimens are indicated in figure 28.

Five types of specimens were used. These included lap shear, drum peel, and wedge tests for the metal laminate areas. Peel and flatwise tension tests were used for the skin-to-core bonds. The specimens were of a standard configuration. Details of the wedge test specimen are shown in figure 29. In some cases where the skin was quite thin, it was necessary to bond on additional material for testing. Accordingly, the metal thickness for both the wedge and lap shear tests was increased to 0.125 in.

Wedge specimens were cut from the metal laminate areas of all of the components. It was felt that this test gave the most critical evaluation of the metal surface preparation quality. Additional types of specimens were selected to evaluate other properties. Honeycomb peel specimens were taken from three areas of the C-141 leading-edge component. These represented areas where three different cleaning methods were used; i.e., nontank anodize, PasaJell 105, and 2% hydrofluoric acid (HF). Metal-to-metal (m/m) peel specimens that had been exposed to salt spray were tested for three components. Lap shear tests were conducted on three other components to verify the design values that had been used for the splice overlap.

One component, the T-38 main landing-gear door, was exposed to simulated flight weathering cycles prior to specimen removal. The exposure consisted of 30 days of 1-hr cycles involving excursions from -67°F with simulated 40,000-ft altitude pressure to $140^{\circ}\text{F}/100\%$ relative humidity at sea level. X-rays taken before and after the exposure indicated that no moisture had entered the core area.

The results of the tests are given in tables 3 and 4. The test results on the C-141 leading-edge repair were quite good. Core failure was obtained with the peel specimens as shown in figure 30. The test values were consistently high. The wedge tests for this component were invalidated because the crack growth jumped to the surface where an additional metal strip had been bonded to increase the metal thickness. Subsequent opening of the repair interface, however, did indicate satisfactory cohesive failure, figure 31.

The metal-to-metal salt spray exposed peel specimens are shown in figure 32. Those from the repaired area of the C-5A aileron component looked very good, and the test values were high. Lower values were obtained on the specimens from the auxiliary power unit (APU) panel and the stabilator. The stabilator specimens were taken from along the laminated

trailing edge. Bondline porosity is indicated along the specimen inside edge where the skin begins to open for the core (see fig. 33). Consequently, this resulted in a loss in peel strength.

The lower failure values for the APU access panel appear to be primarily a problem with inadequate curing pressure on the repair details. The cure was made using a vacuum bag. The patches were preformed by roto-peening. The core plug was not preformed. It was expected that the plug would form into place with the bonding pressure. This did happen, but the result was apparently some reduction in pressure in the metal-to-metal bondlines next to the core. This was indicated by the lowered peel and wedge values and was additionally apparent by examination of the failure surfaces. They did show that the use of vacuum bag curing should be limited to simple repairs. Double contoured details especially present a problem because of their inherent configuration stiffness and the increased pressure required to pull the details into intimate contact. The use of extra adhesive in these areas offers one possible solution.

Values from the A-6 fin panel repair were very good. Core failure was obtained with the honeycomb peel specimens, shown in figure 34. The failed lap shear specimens are shown in figure 35. The values obtained were comparable to those obtained for that adhesive (AF127-3) during Phase II of this program.

The failure surfaces of wedge specimens from the T-38 main landing-gear door are shown in figure 36. High crack growth is noted on one specimen. (See the following note and listing.) This is the specimen to the right in the photo that shows a high percentage of adhesive failure. *This may be attributed to inadequate surface preparation.* Apparently the surface did not anodize properly. However, results from the other three specimens were satisfactory with crack growth within the range of expected values.

Note: An arbitrary rating has been established for wedge test values. This is shown below. This rating is primarily applicable to the 250° F curing epoxies. The value of the wedge test data is less defined for other adhesives.

| <u>1-hr crack growth, in.</u> | <u>Rating</u> |
|-------------------------------|----------------------------|
| 0.0 to 0.10 | Very good |
| 0.11 to 0.25 | Good |
| 0.26 to above | Marginal to non acceptable |

For processing control, the average of 10 specimens should not exceed 0.25 in., and no individual value should exceed 0.75 in. to be acceptable.

Failure surfaces of the wedge tests for the F-111 spoiler are shown in figure 37. The values were consistently good. The failed lap shear specimens are shown in figure 38. Some porosity is apparent in the two outside specimens. This was undoubtedly due to some reduced bonding pressure in these areas. The values were still quite adequately above the design requirement of 1300 lb/in. (see sec. 2).

A major problem was encountered with the repair on the F-111 titanium fuselage panel. Two wedge and two lap shear specimens were tested, as shown in figure 39. The adhesive is FM400. The values were poor, and the adhesive failed clean from the metal surface. *It was concluded that further work needs to be done to develop a satisfactory nontank surface preparation method for titanium.*

It is evident, in conclusion, that considerable care must be taken to ensure adequate pressure on the adhesive bondlines. Rigid details, such as those having compound curvature, especially present pressure application problems. Special care must be taken to ensure that the details fit properly. Where possible, the higher pressure provided by an autoclave should be used rather than a vacuum blanket.

Attention to proper surface cleaning is exceedingly important. In many repair applications, the use of a nontank procedure is necessary. Proper procedures must be used if a high quality bonding surface is to be obtained. Masking should be used to prevent contamination of surrounding areas. All bond surfaces should be carefully inspected to ensure that they have been prepared properly prior to bonding. Additional work on a repair compatible surface preparation method for titanium is necessary.

5.0 HANDBOOK PREPARATION STATUS AND COMPLETION PLANS

The draft completion status of the various sections of the handbook is as follows:

| Section | Title | Completion status |
|---------|---------------------------|-------------------|
| 1.0 | Introduction | Complete |
| 2.0 | Damage assessment | Complete |
| 3.0 | Repair Method Selection | Complete |
| 4.0 | Materials and Processes | Complete |
| 5.0 | Surface Preparation | Complete |
| 6.0 | Small Area Repairs | Complete |
| 7.0 | Large Repair Methods | In Work |
| 8.0 | Equipment and Facilities | In Work |
| 9.0 | Tooling | In Work |
| 10.0 | Nondestructive Inspection | Complete |

Drafts of the incomplete sections will be completed during Phase V. These will be coordinated with the Air Force technical program monitors for final release.

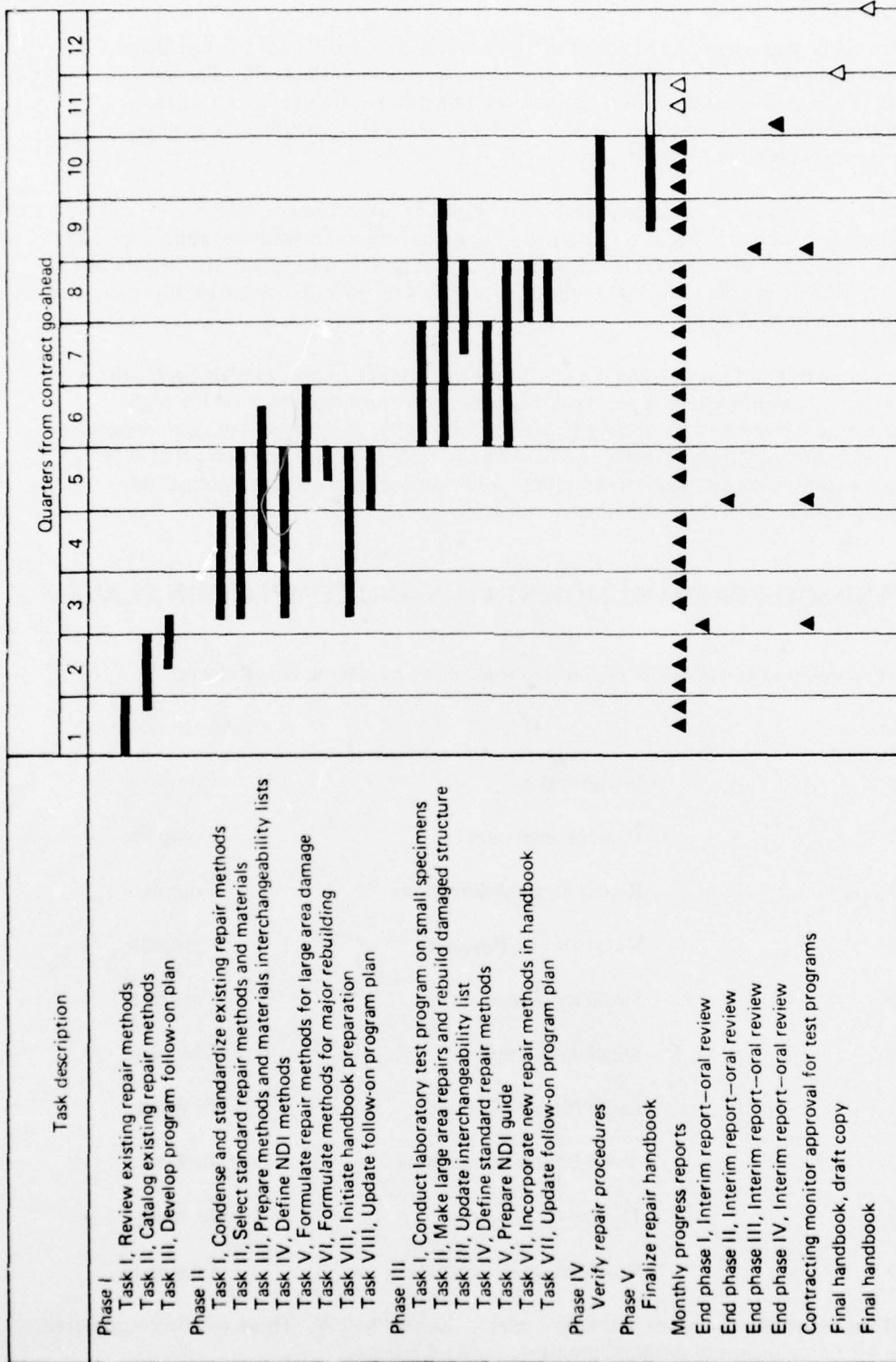

Figure 1.—Program Schedule

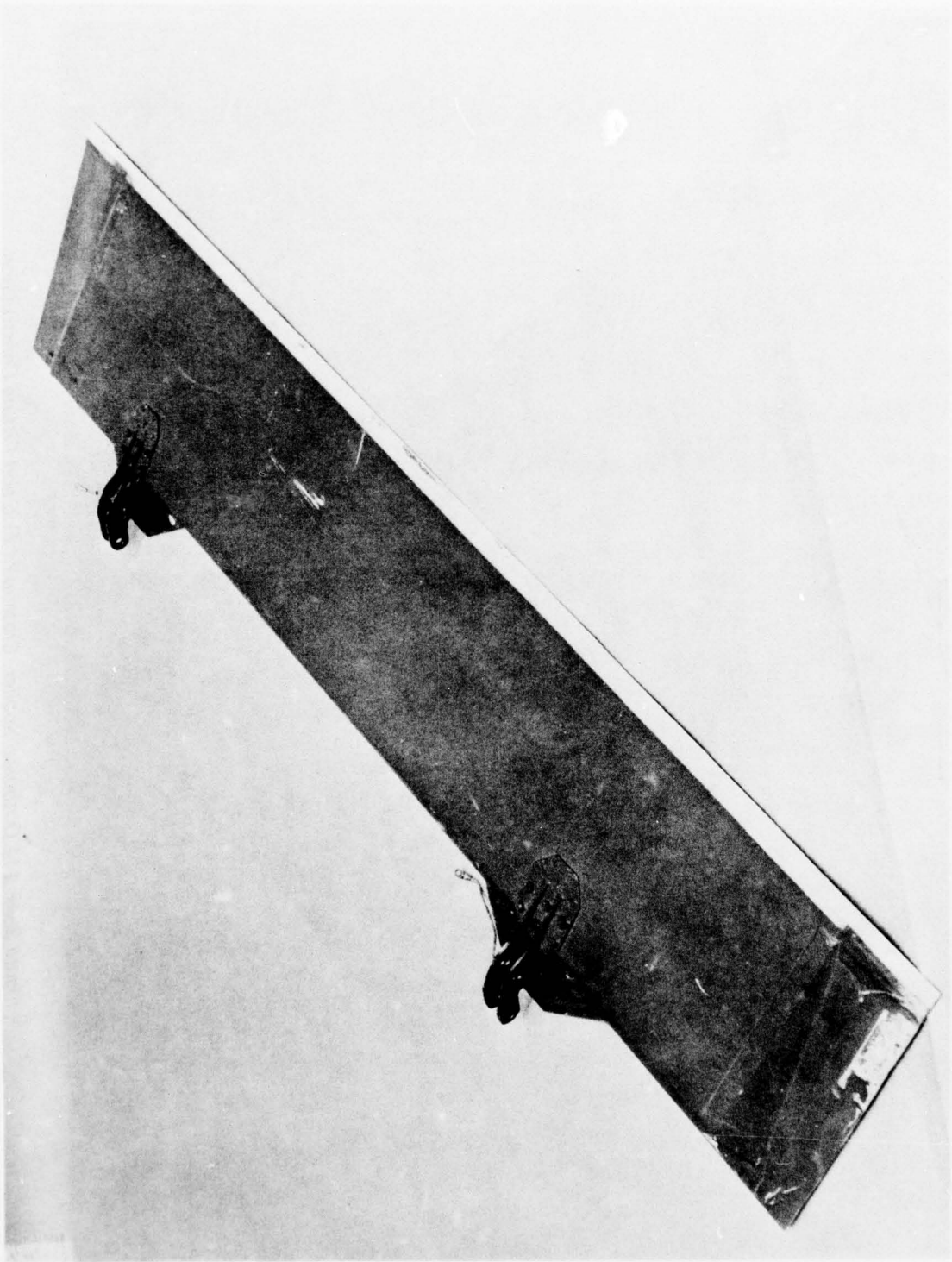

Figure 2. — F-111 Outboard Spoiler

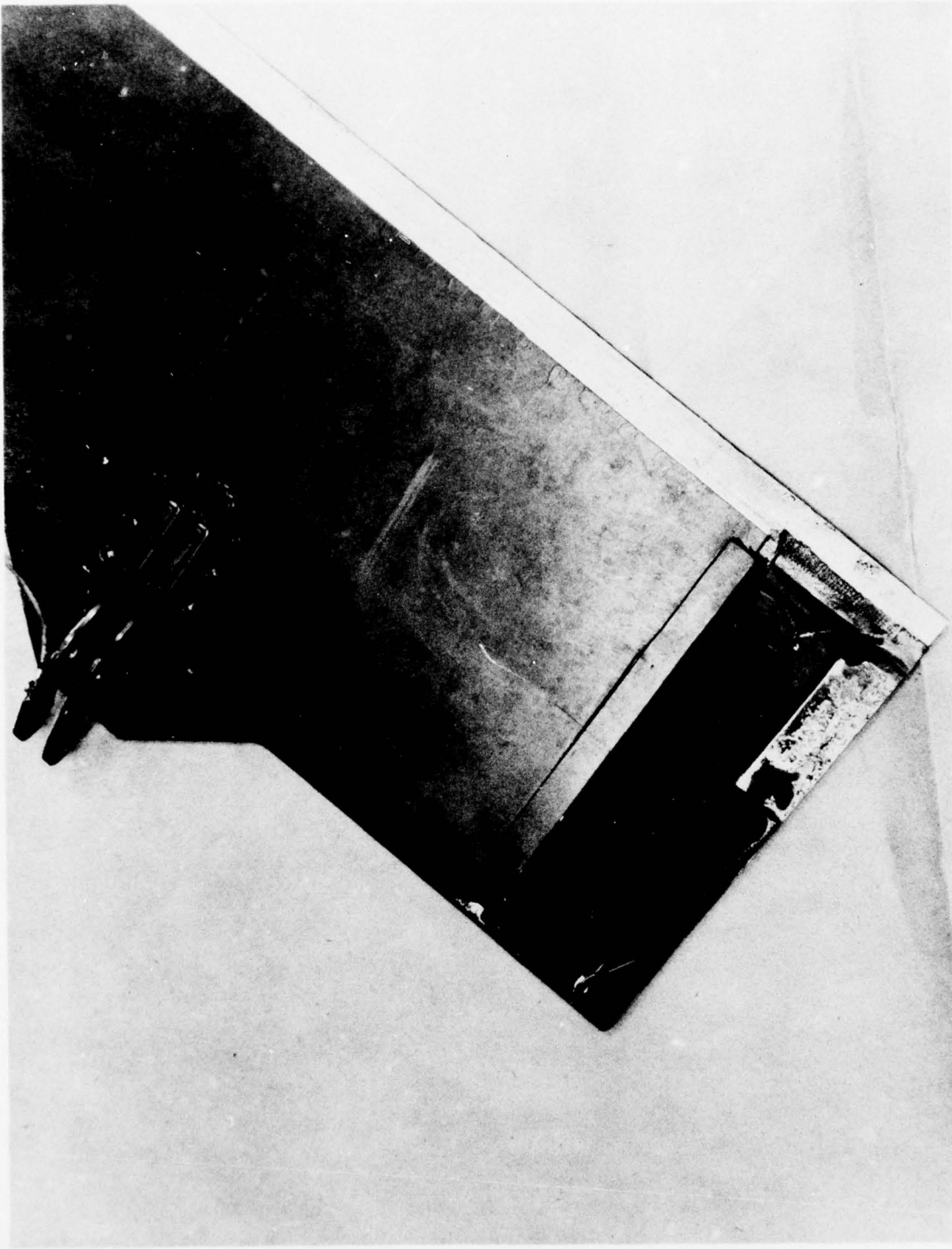

Figure 3.—F-111 Outboard Spoiler, Closeup of End and Fitting Construction

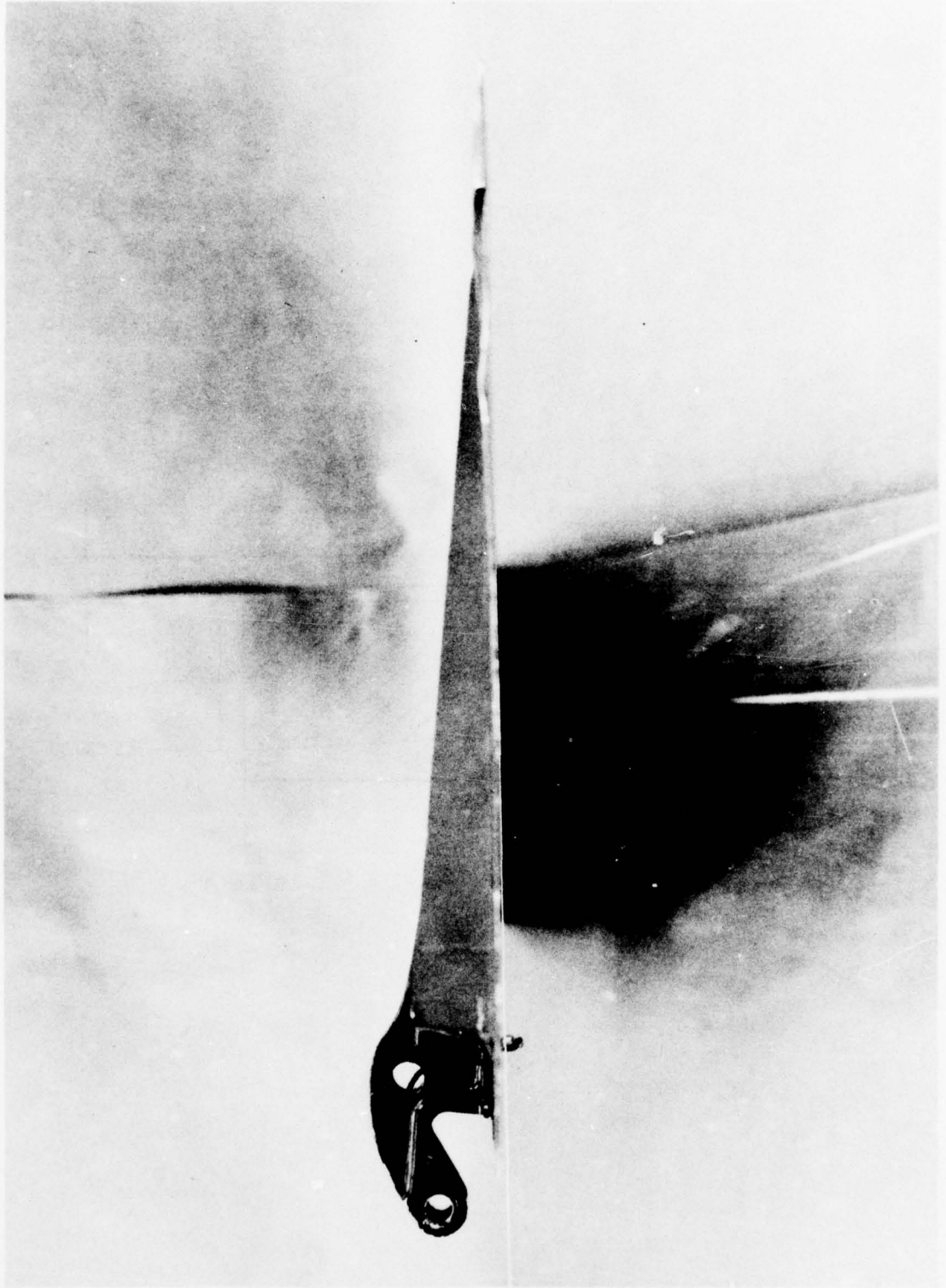

Figure 4.— Outboard Spoiler, End View

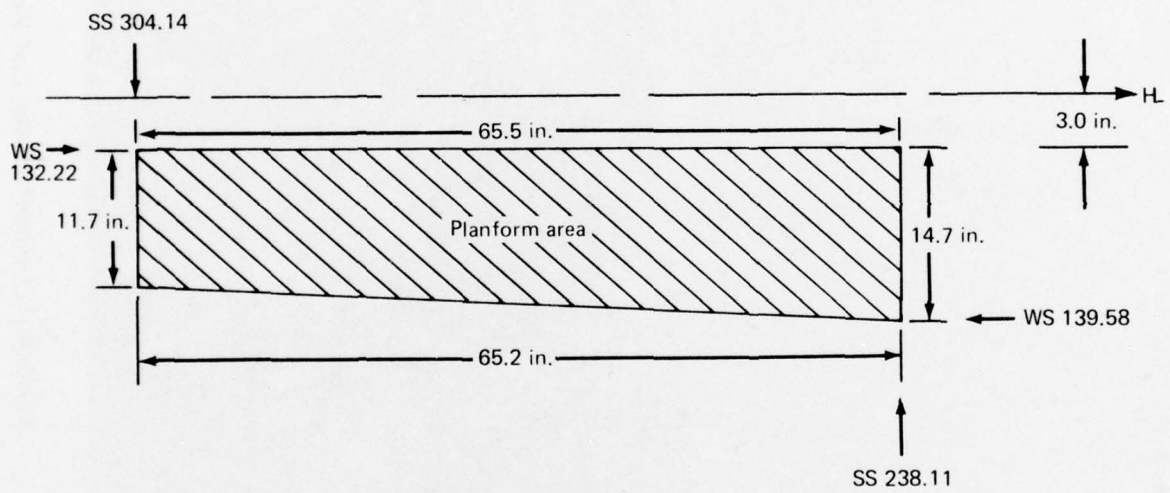
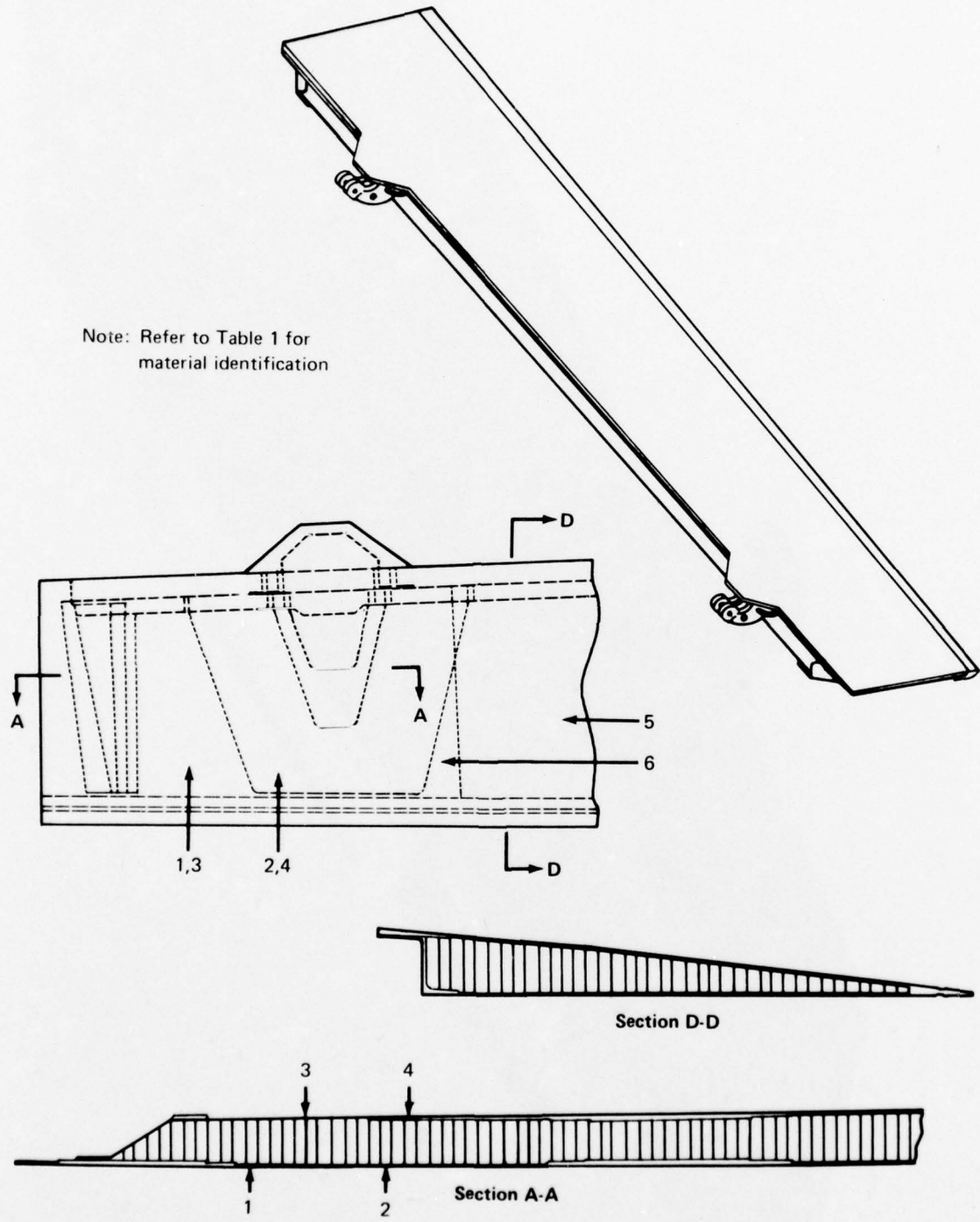

Figure 5.—Spoiler Planform Geometry (ref. 1)



Note: Refer to Table 1 for material identification

Figure 6.—Details of Spoiler Construction

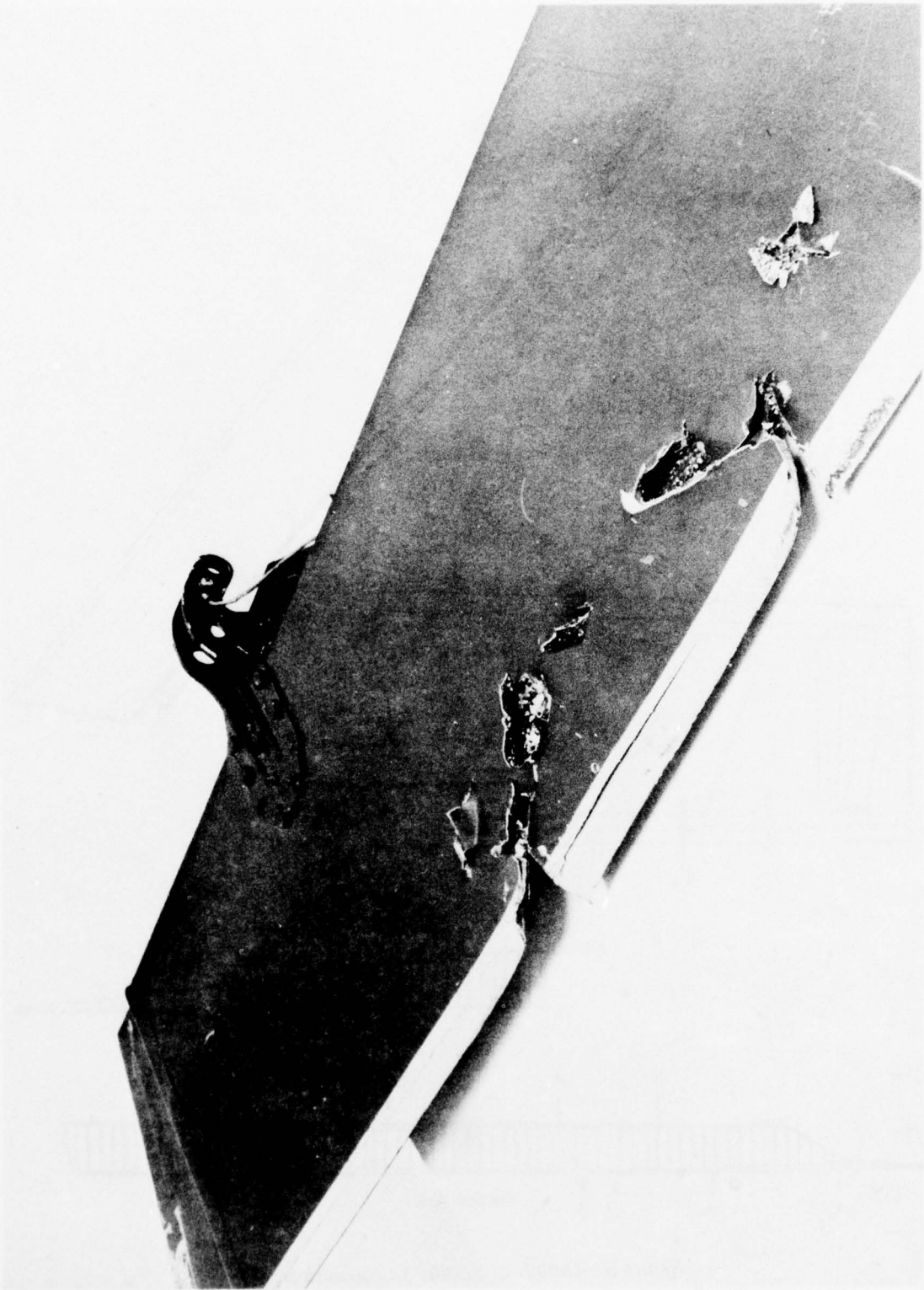

Figure 7. — Damaged F-111 Spoiler

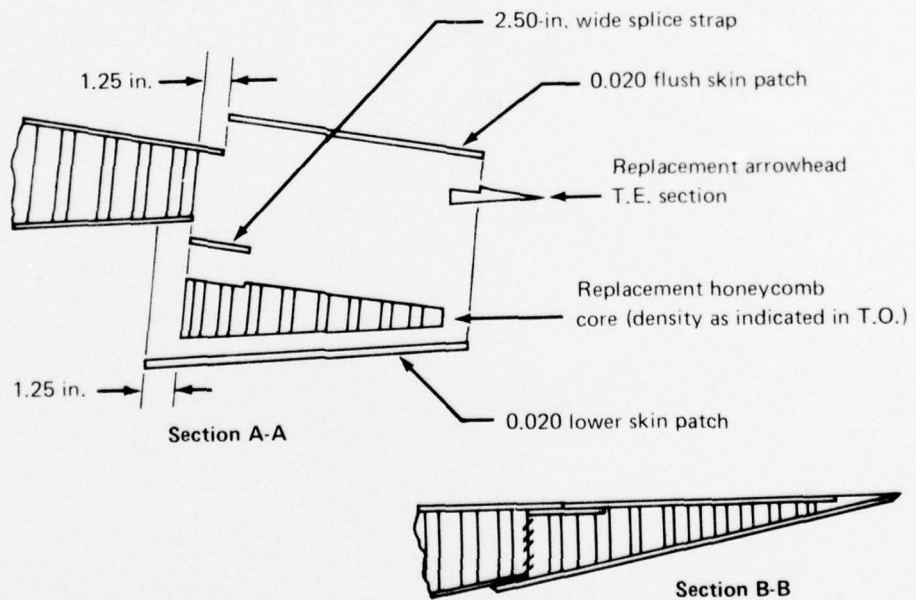
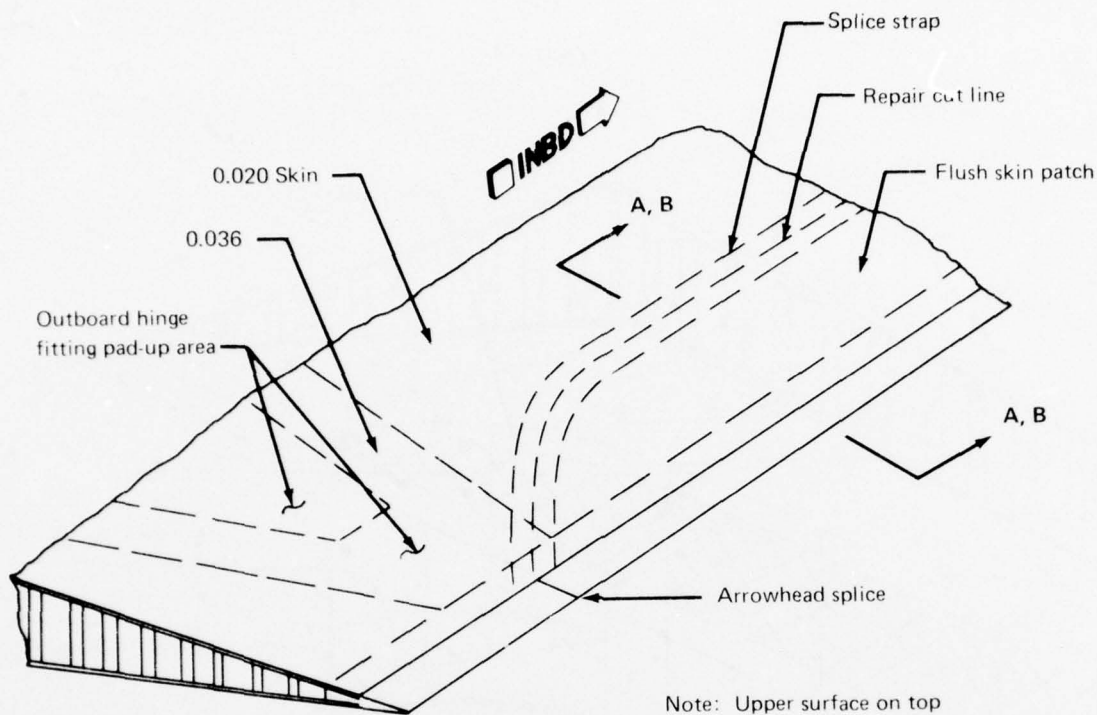

Figure 8.—F-111 Outboard Spoiler Upper Surface and Repair Cross Section

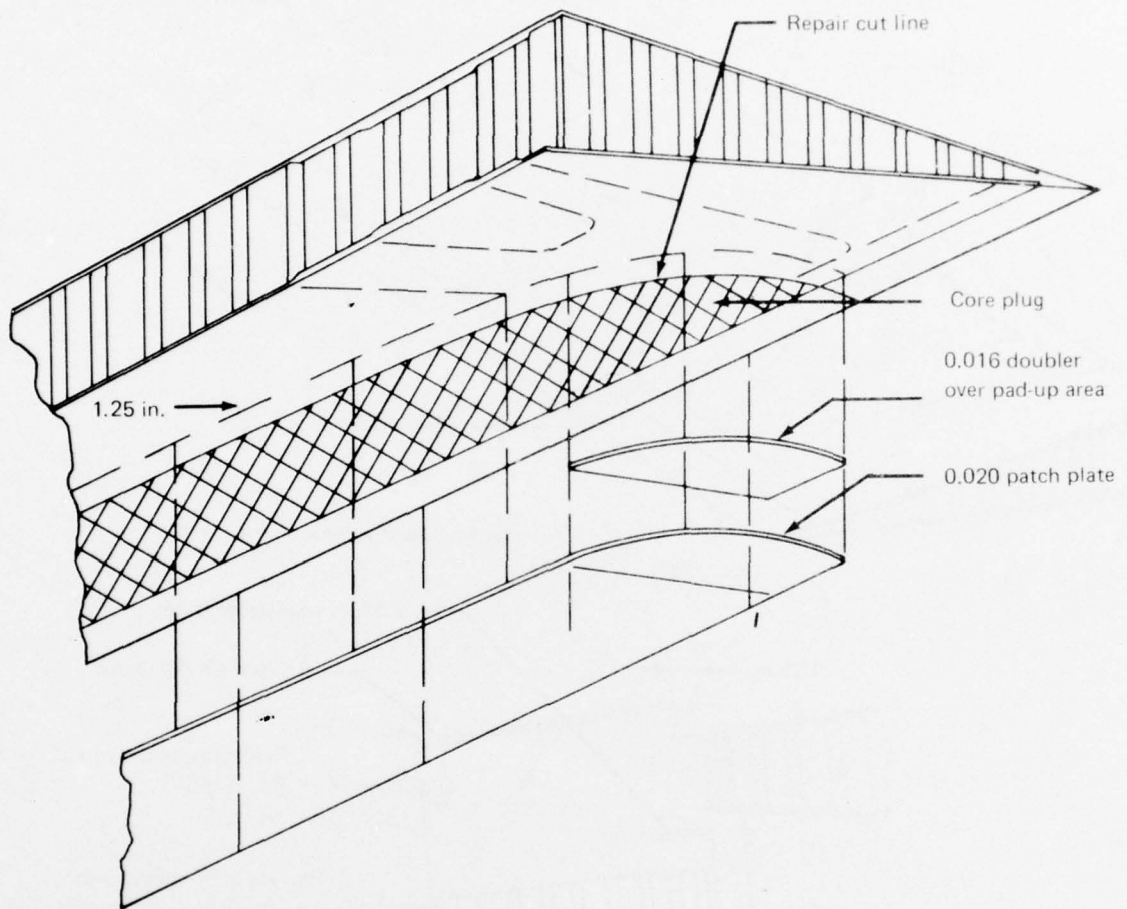

Figure 9.—View of the Lower Surface Repair Details

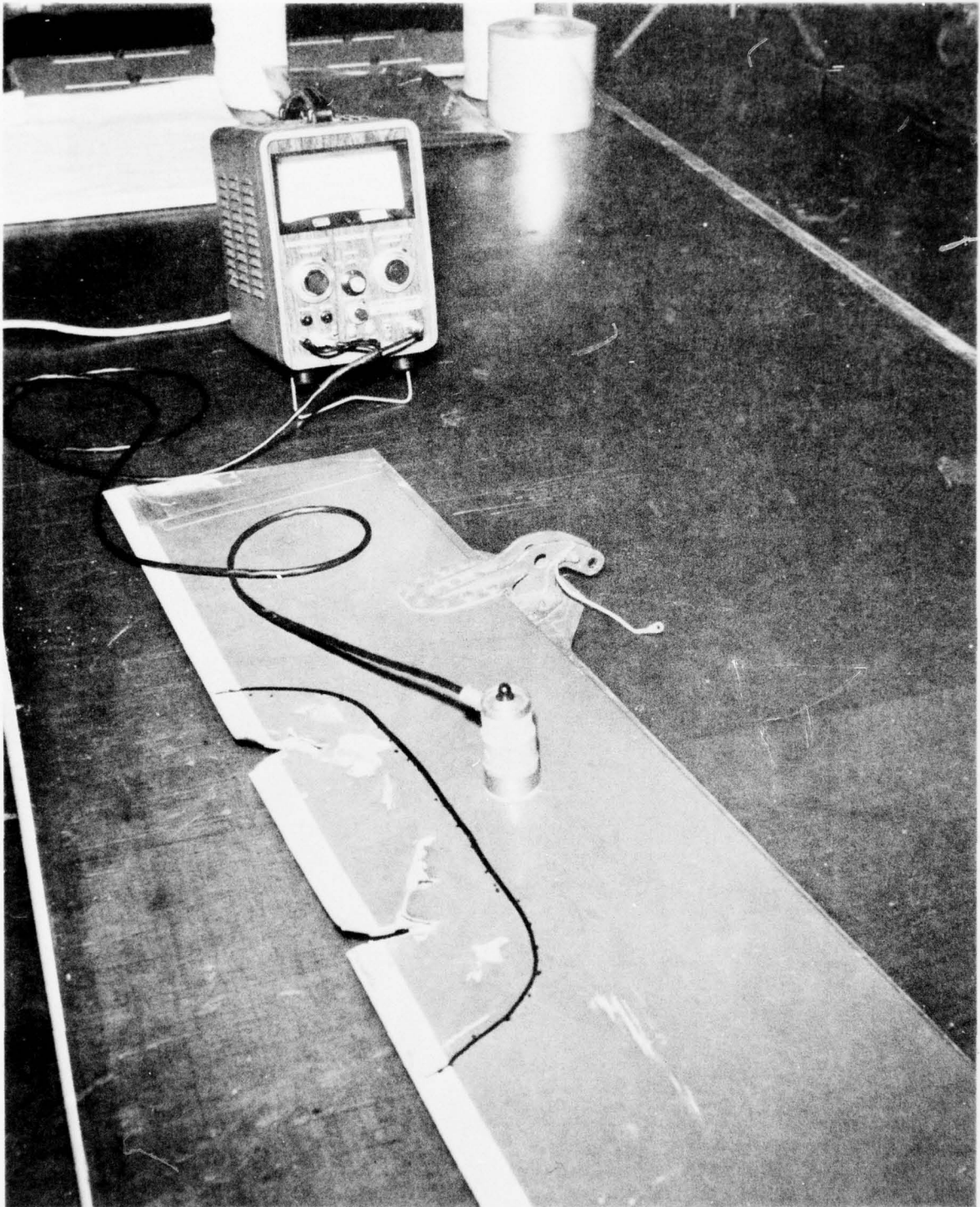

Figure 10.—Ultrasonic Inspection of the Damaged Spoiler

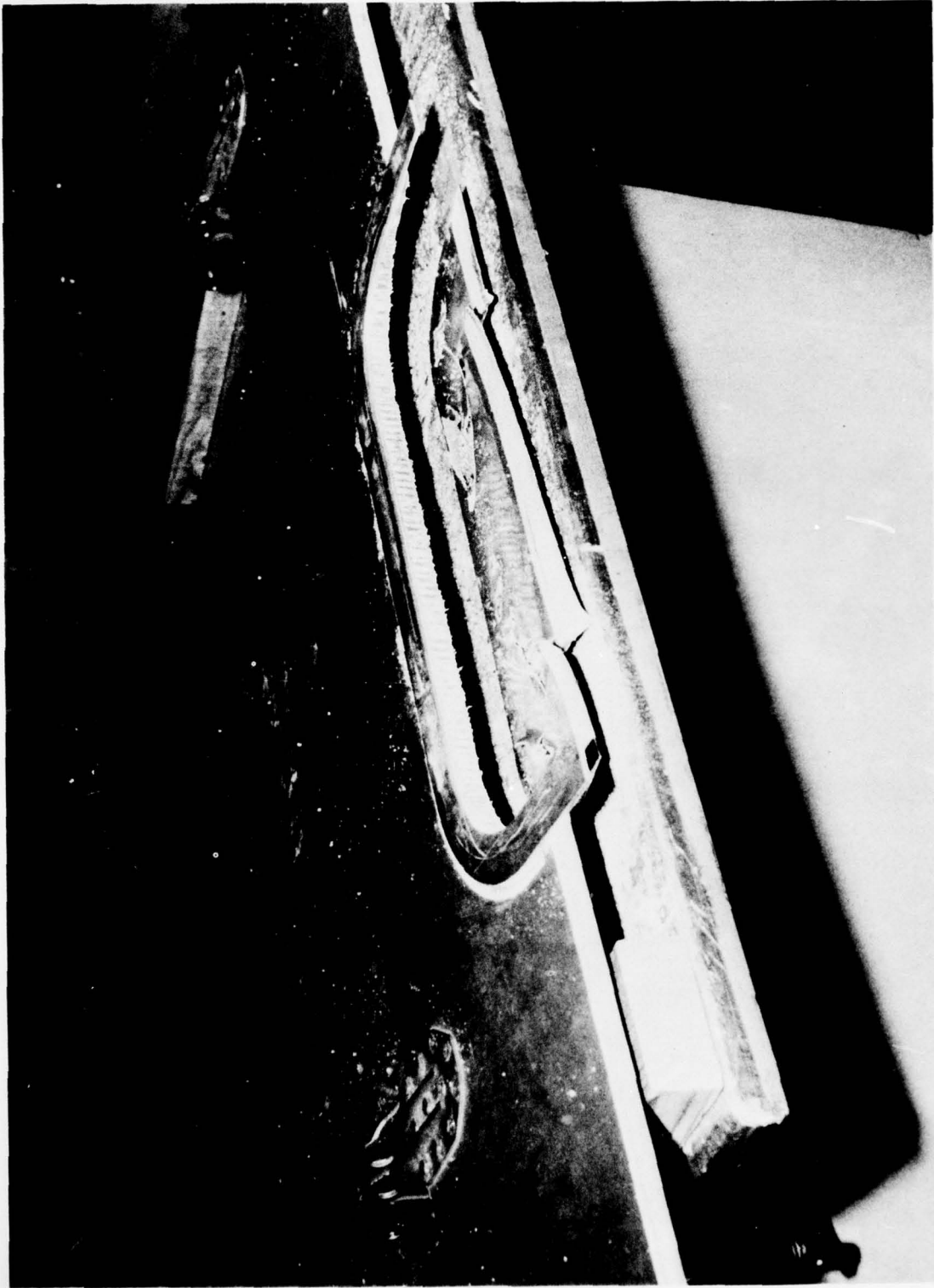

Figure 11.—Removal of the Damaged Material

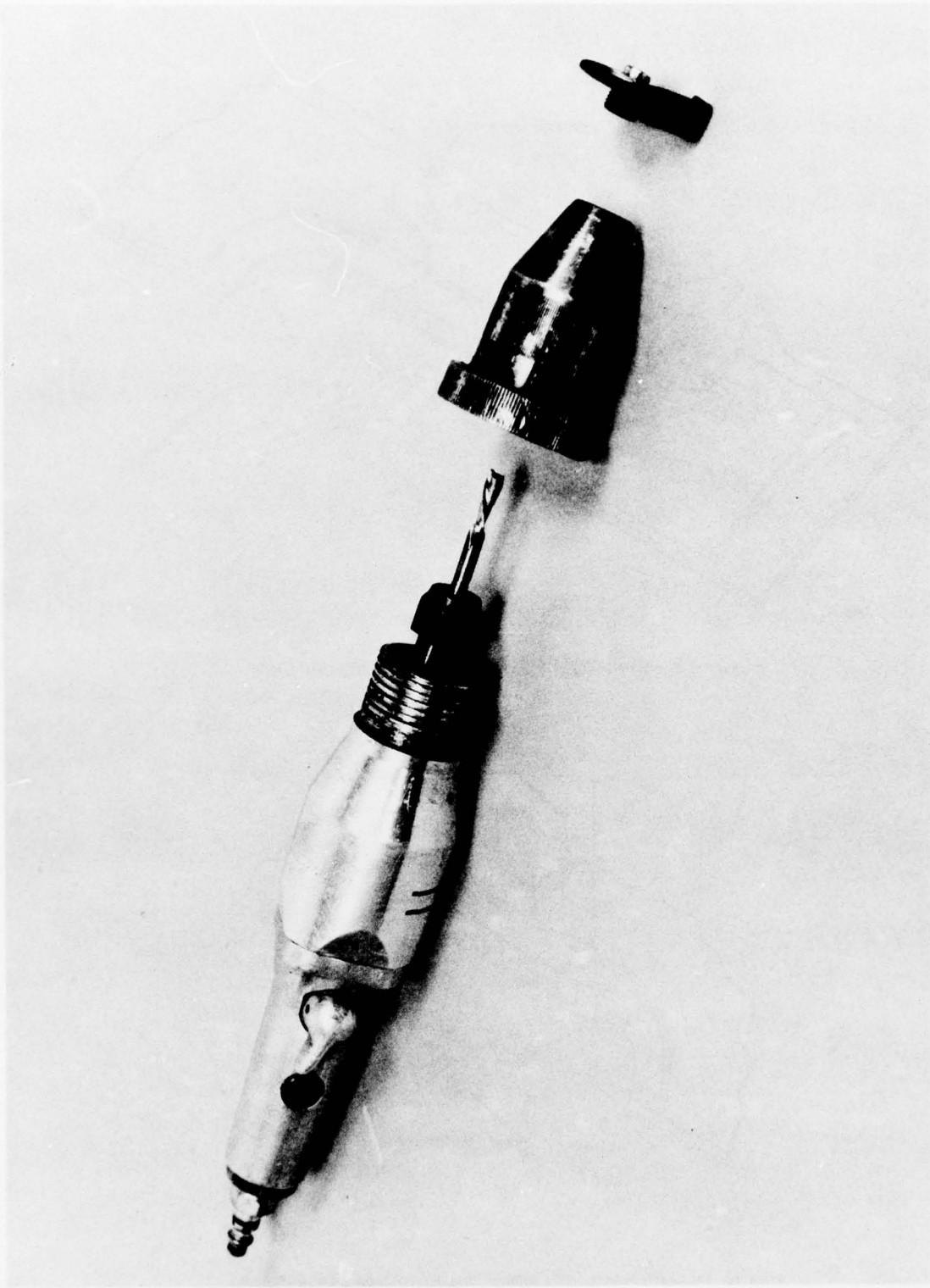

Figure 12.—High-Speed Router Assembly

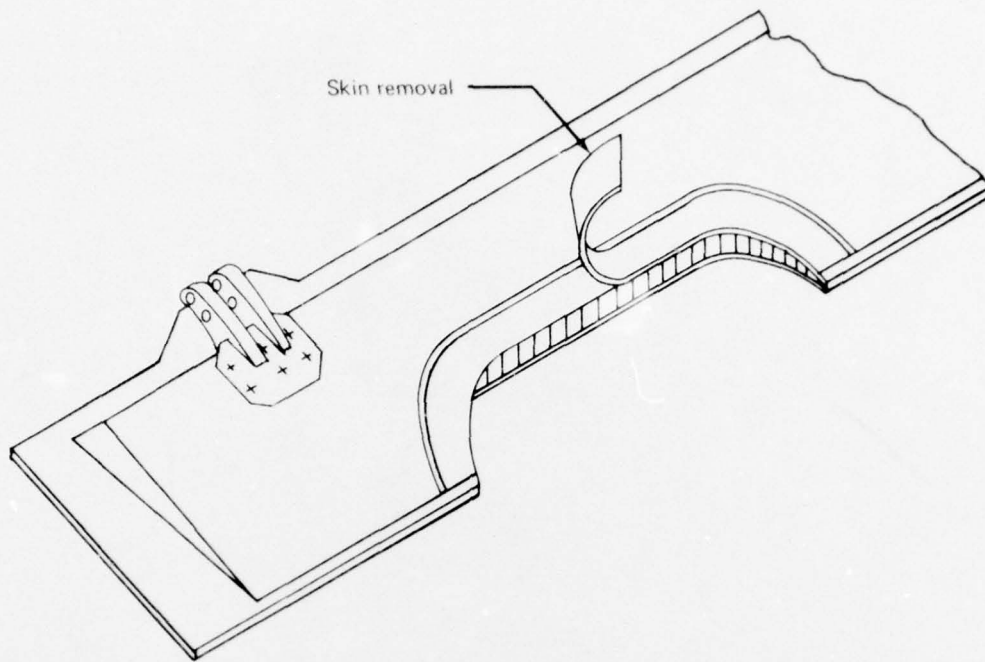

Figure 13.—Removal of Skin Strip After Router Cuts

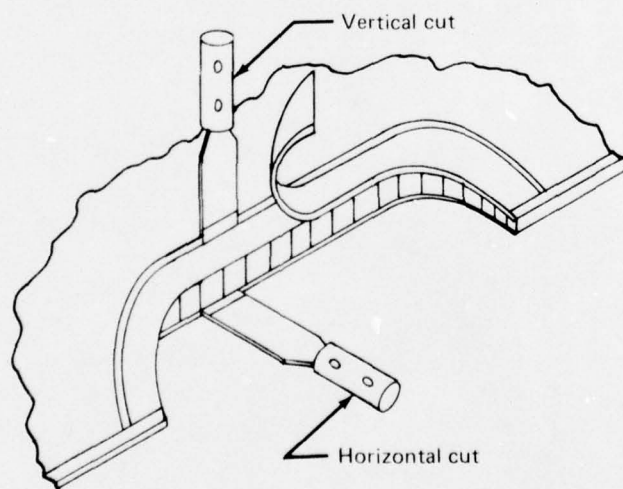

Figure 14.—Removal of Core Strip From the Repair Area

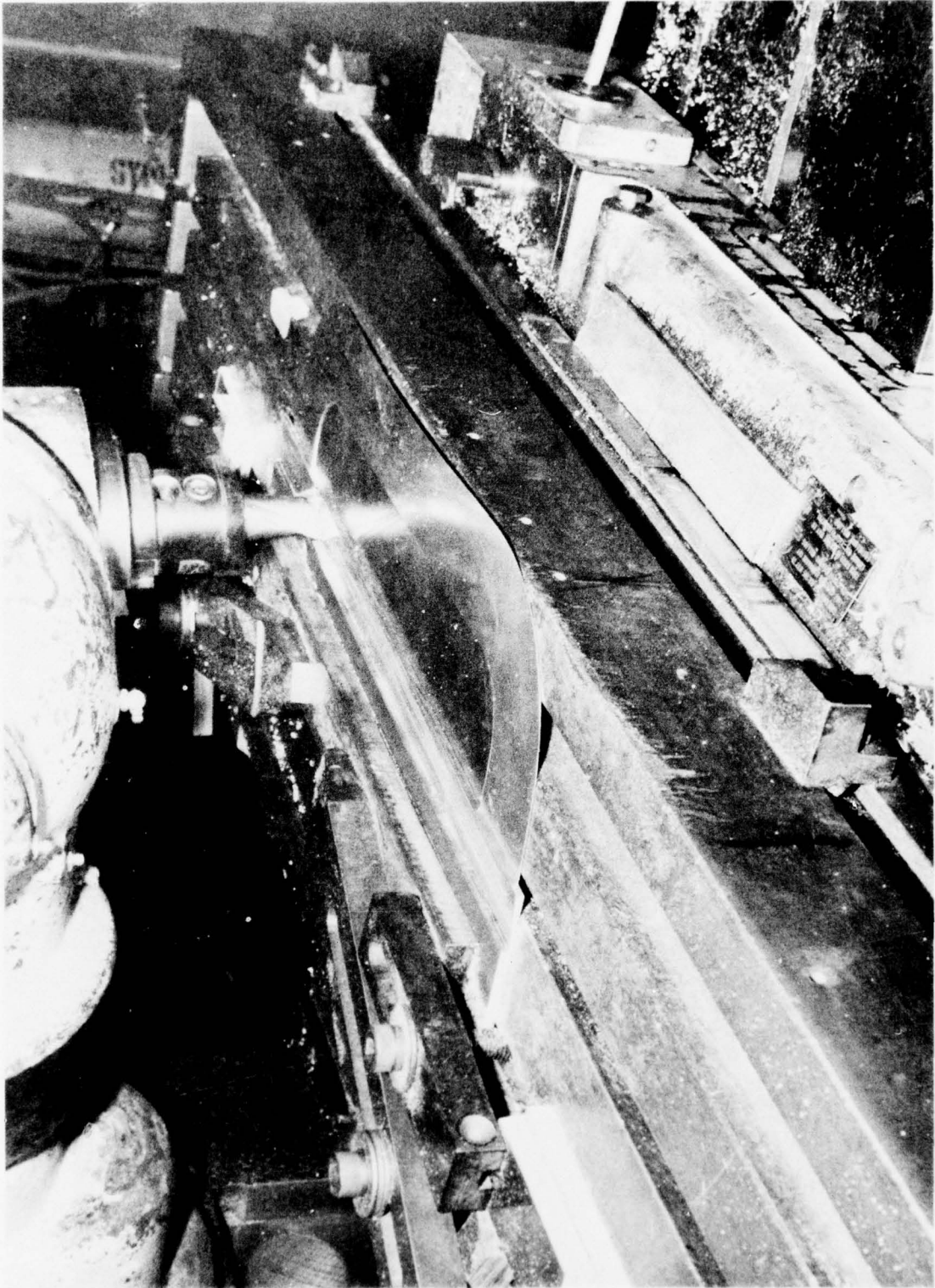

Figure 15. — Machining the Sheet Metal Repair Details

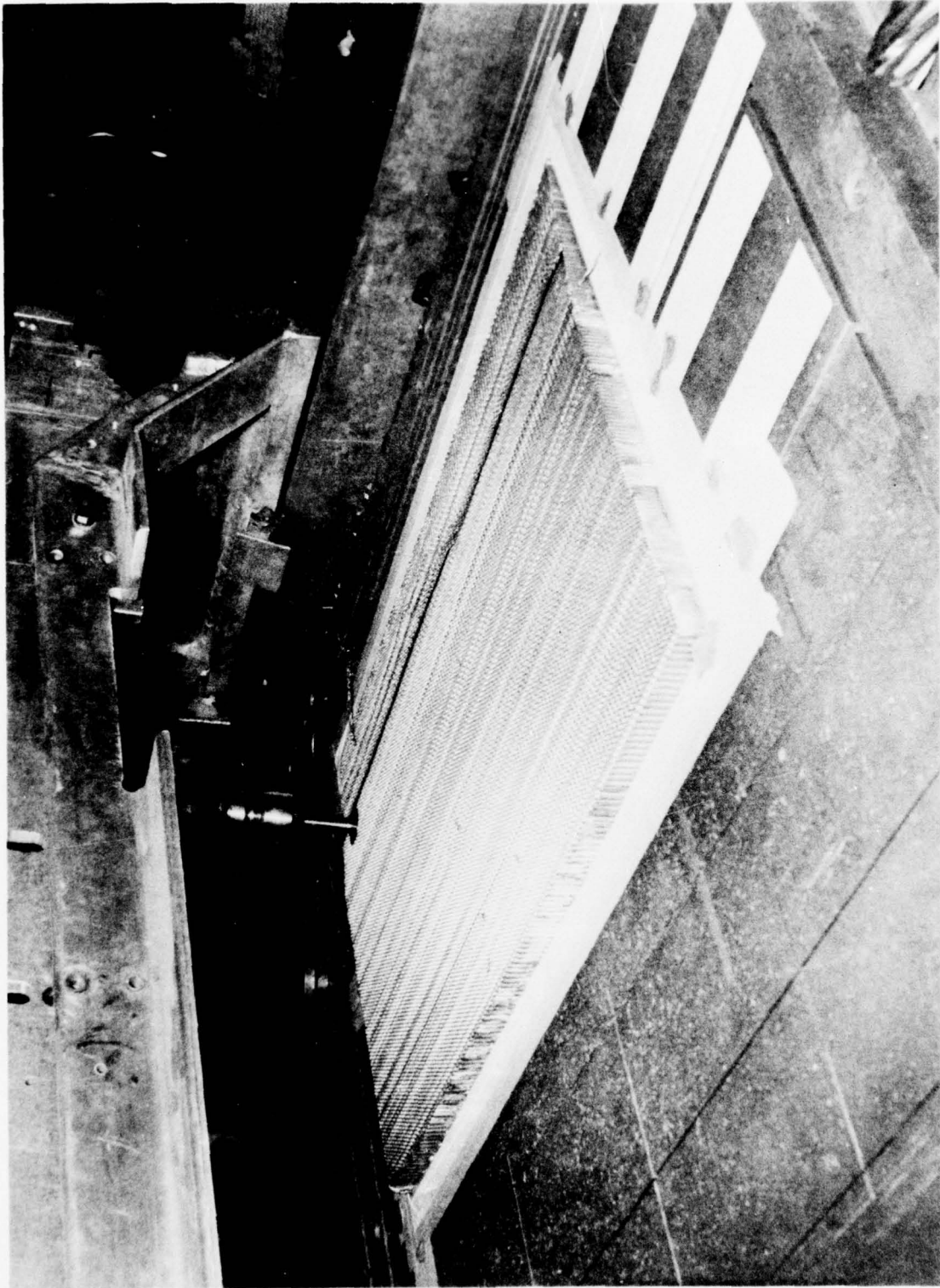

Figure 16. — Machining the Core Repair Detail

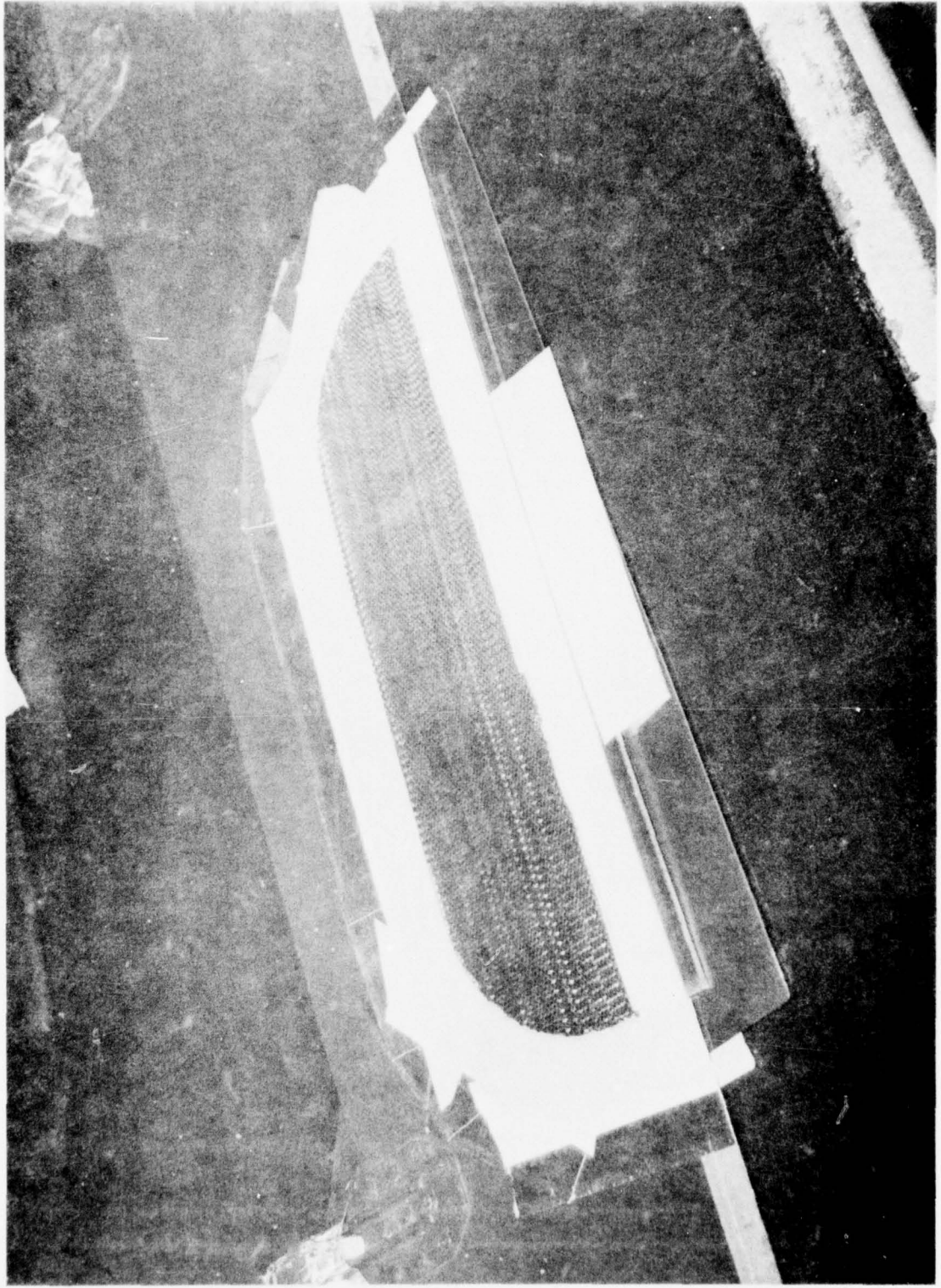

Figure 17.—Details Assembled for the First-Stage Cure

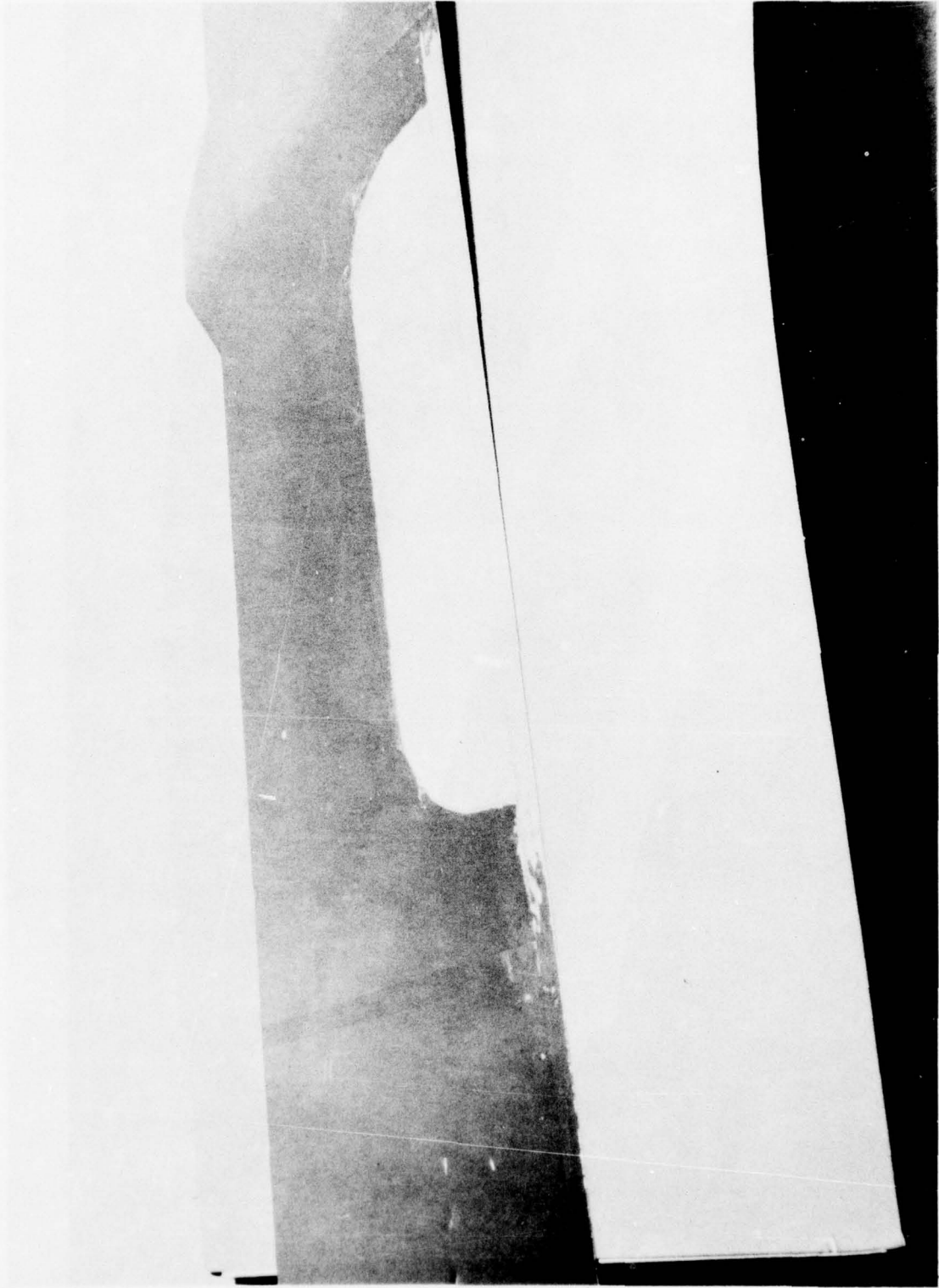

Figure 18. — Flush Patch on the Upper Surface

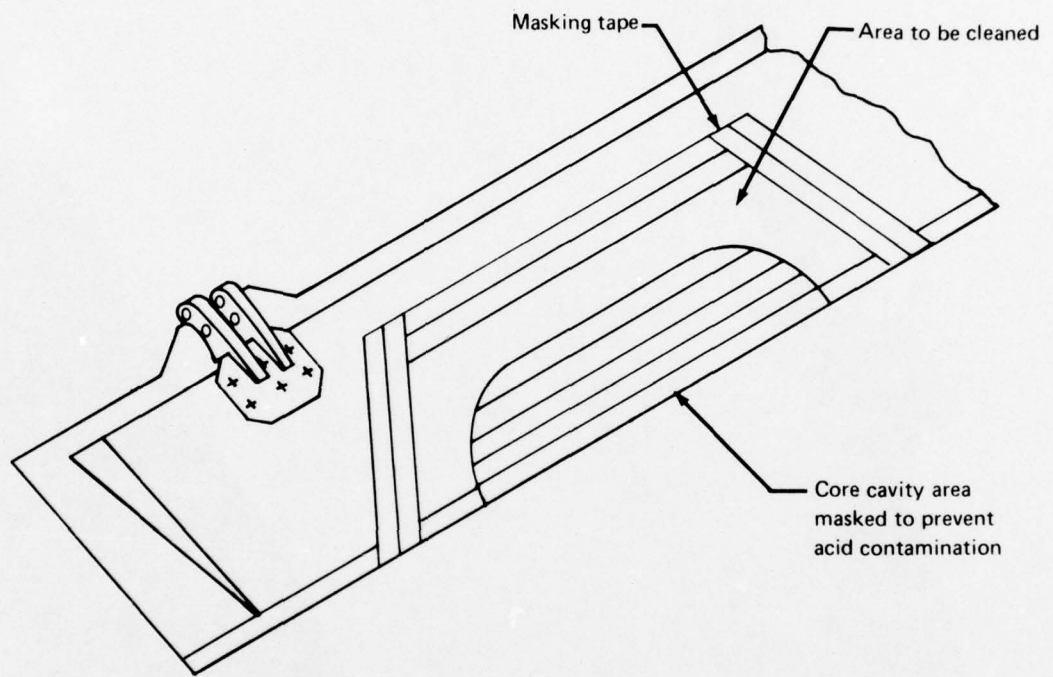

Figure 19.—Areas Masked to Prevent Acid Contamination During Surface Preparation for Bonding Closure Skin Patch



Figure 20.—Nonflush Patch on the Lower Surface

Note: Load shown is 150% DLL for
the spoiler surface deflected
 20° (ref. 6)

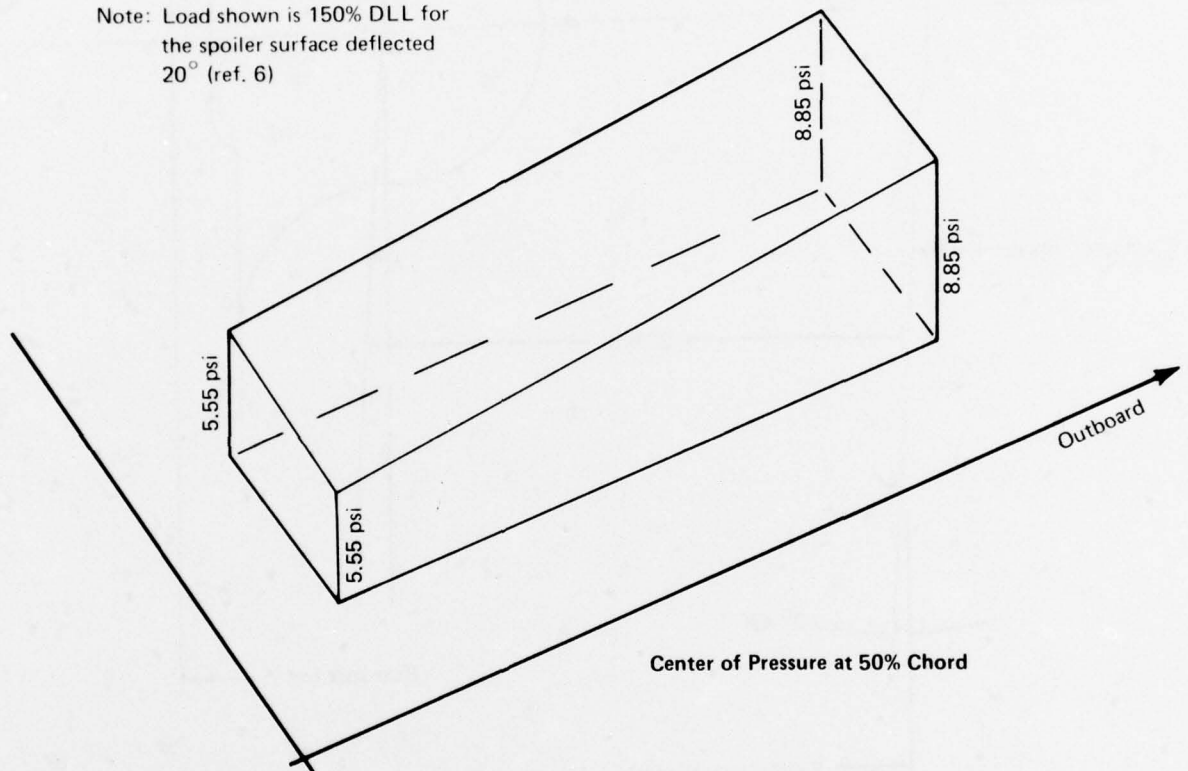

Figure 21.—F-111 Spoiler Load Distribution

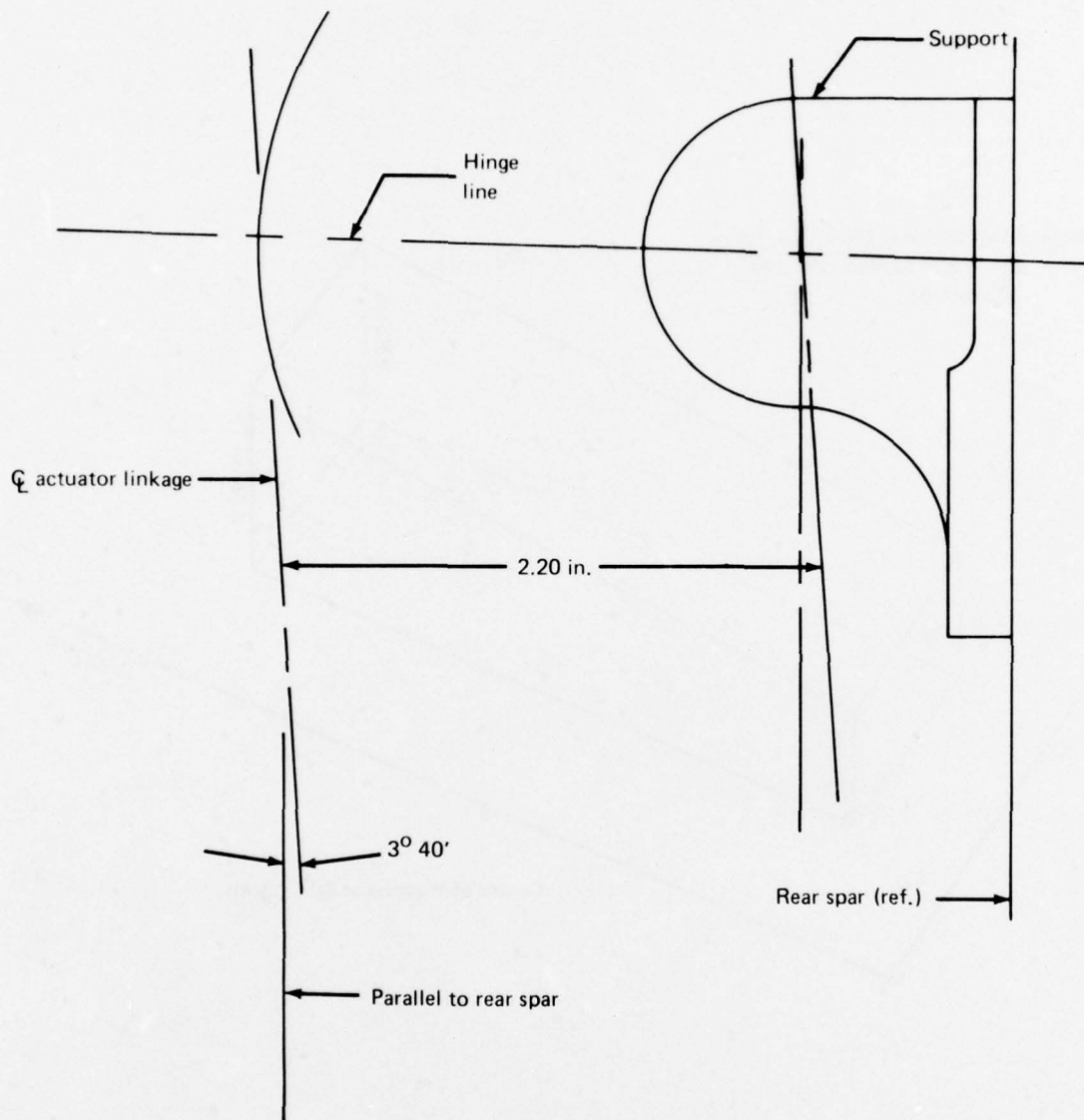

Figure 22.—Position of the Actuator Linkage With the Spoiler Extended 20°

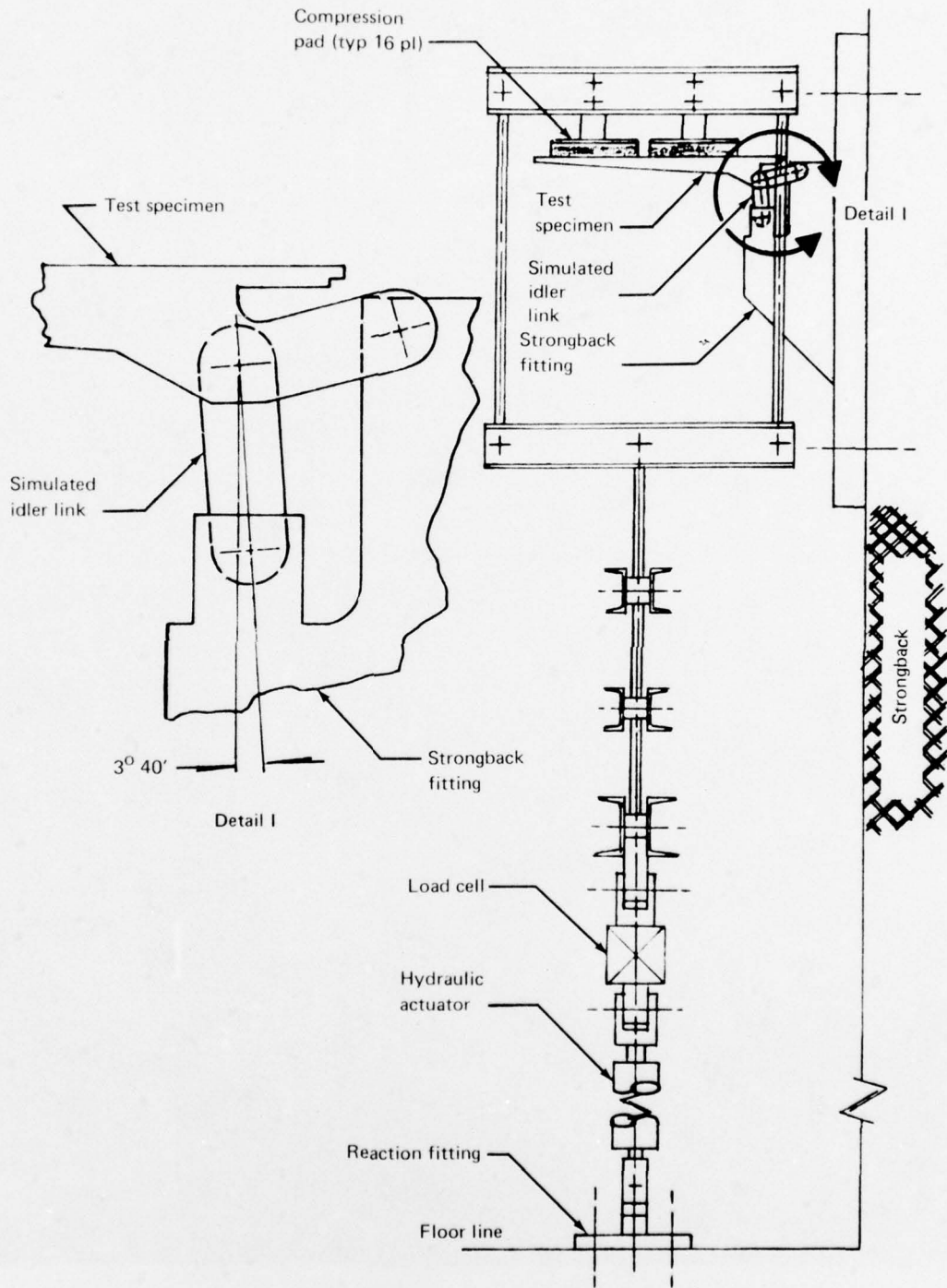

Figure 23.—Sketch Showing the Test Setup for the F-111 Spoiler

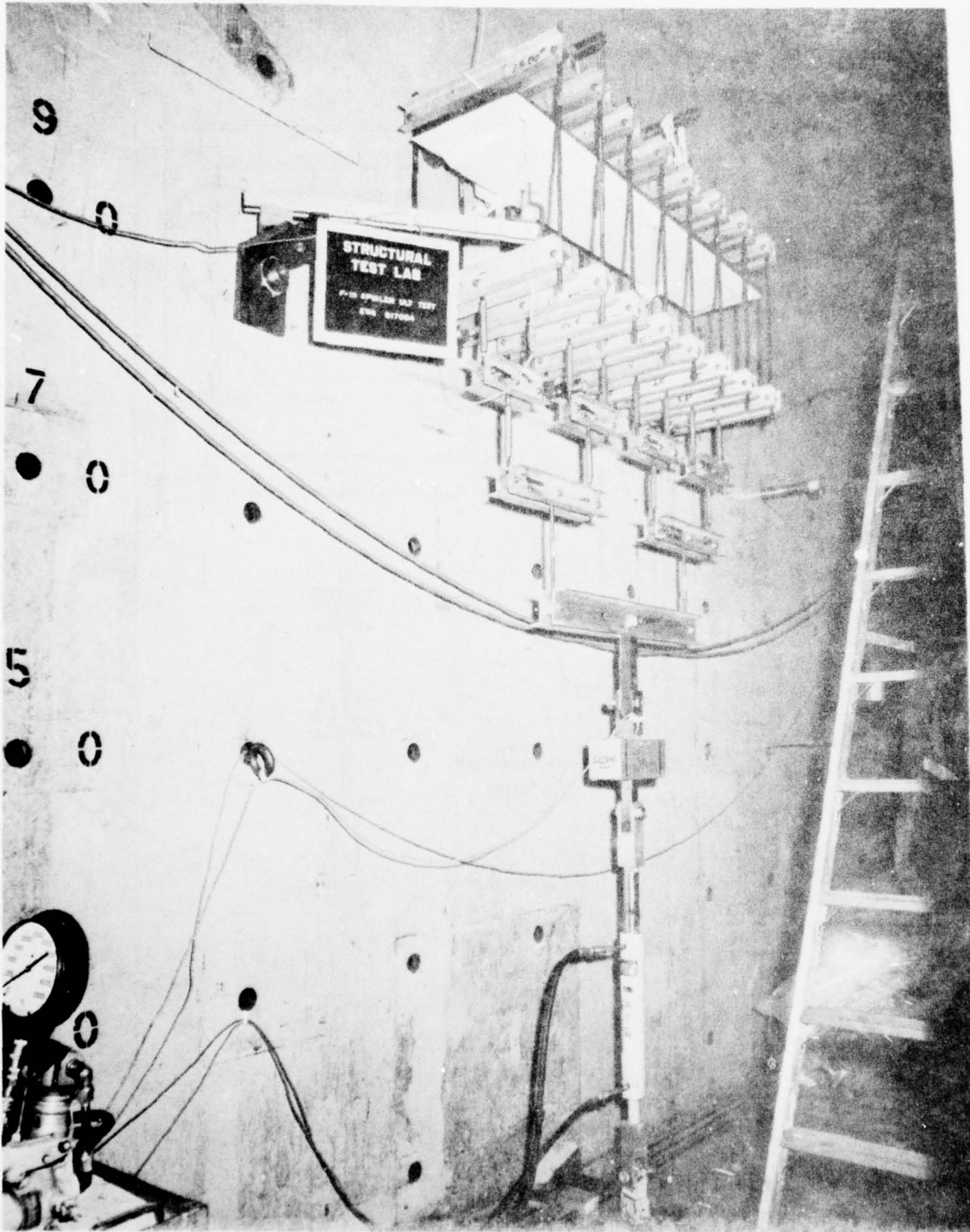

Figure 24.—Repaired F-111 Spoiler Mounted on the Strongback For Test

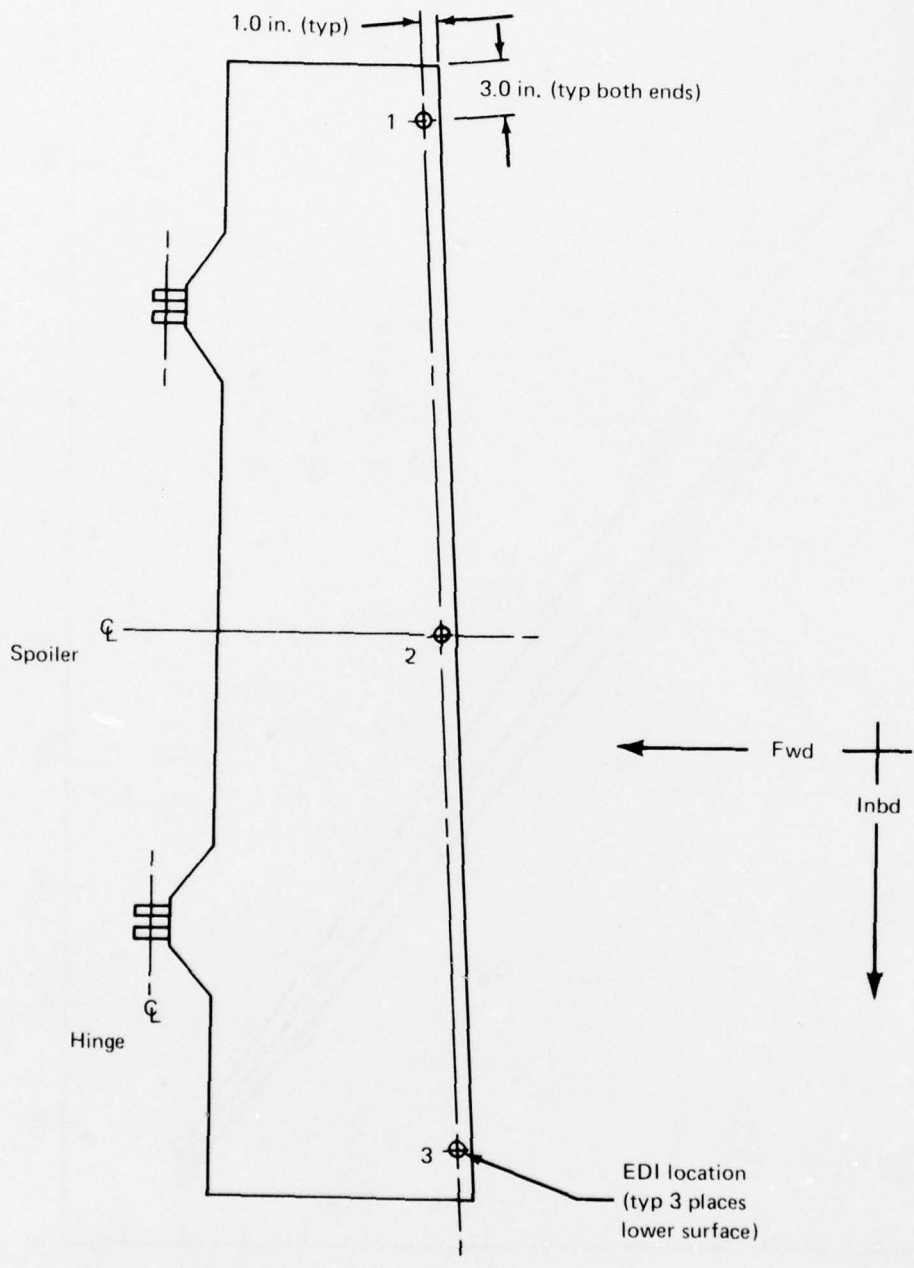

Figure 25.—Location of Electrical Deflection Indicators

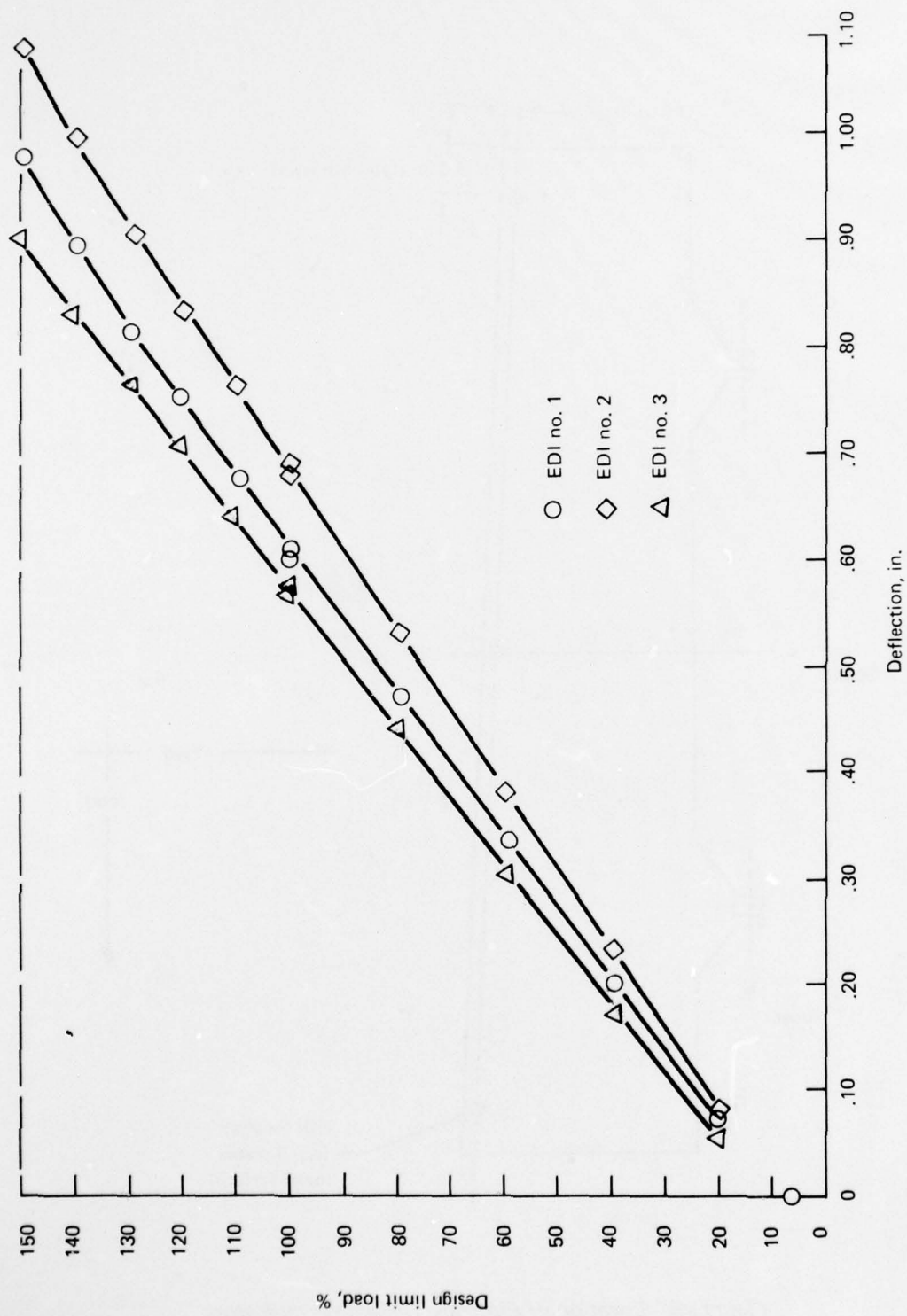

Figure 26.—Plot of Deflection Readings

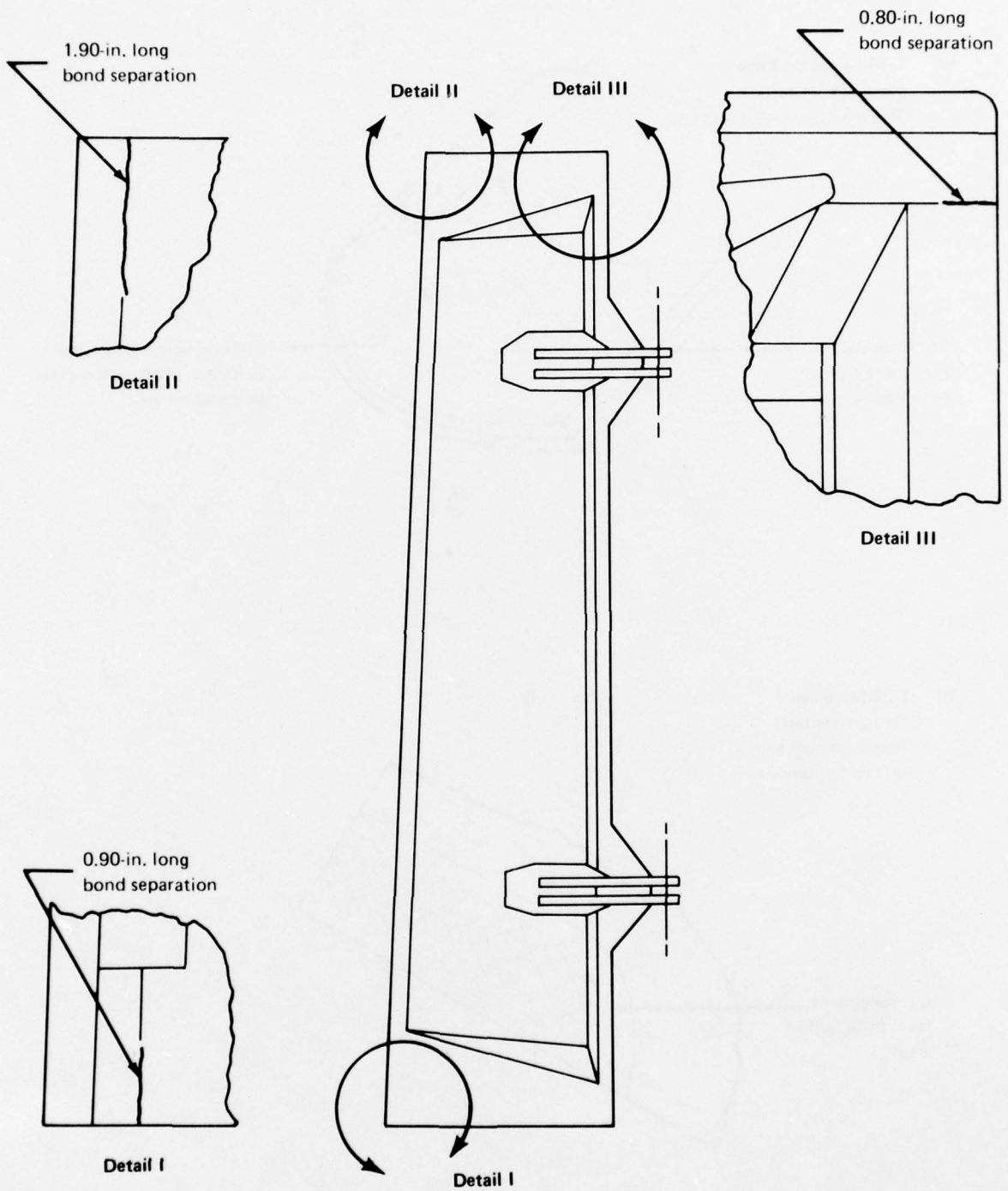
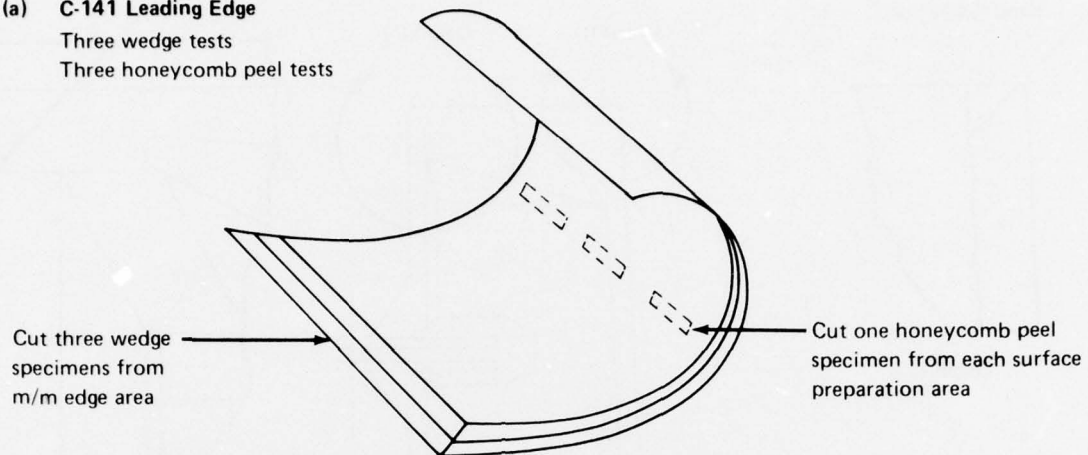

Figure 27.—Areas of Bond Delamination

(a) **C-141 Leading Edge**

Three wedge tests
Three honeycomb peel tests



(b) **T-38 Stabilator**

Two wedge tests
Two m/m peel tests
(salt water exposure)

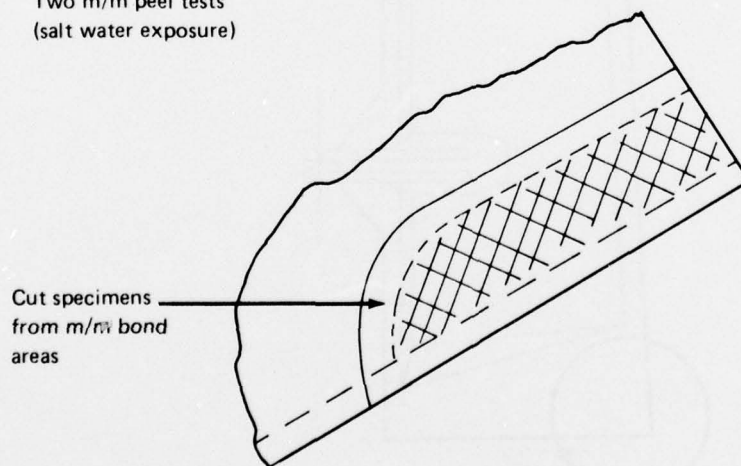
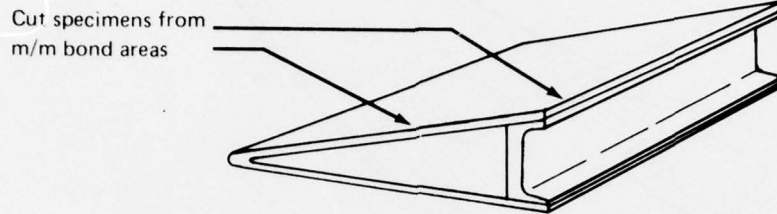

Figure 28.—Component Specimen Testing

- (c) **C5-A Aileron Trailing Edge**
Three wedge tests
Three m/m peel tests (salt spray exposure)



- (d) **F-111 Titanium Fuselage Panel**
Three lap shear tests
Three wedge tests

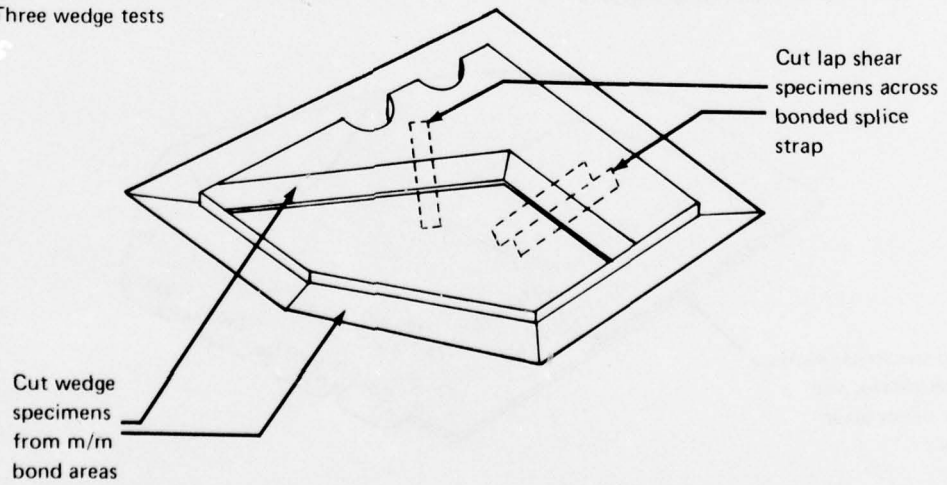
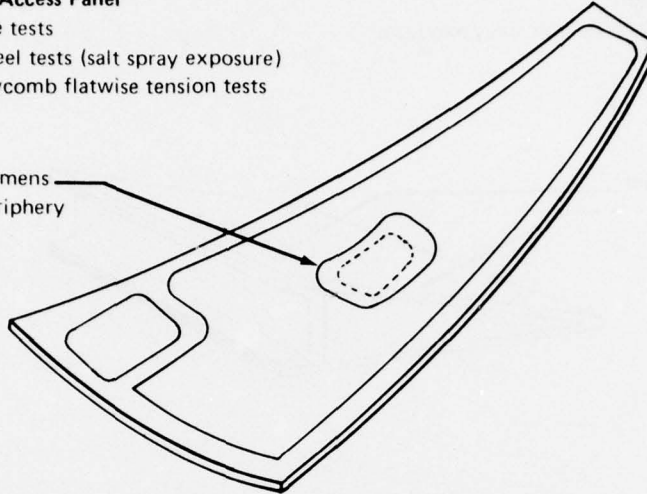

Figure 28.—Component Specimen Testing (Continued)

(e) **C-141 APU Access Panel**

- Three wedge tests
- Two m/m peel tests (salt spray exposure)
- Three honeycomb flatwise tension tests

Cut m/m specimens
from patch periphery



(f) **T-38 Main Landing Gear Door**

- Four wedge tests
- Expose for 30 days in flight
simulation cabinet, x-ray before
and after to detect water ingestion

Cut two specimens each
from the interior and
exterior patch plate
periphery

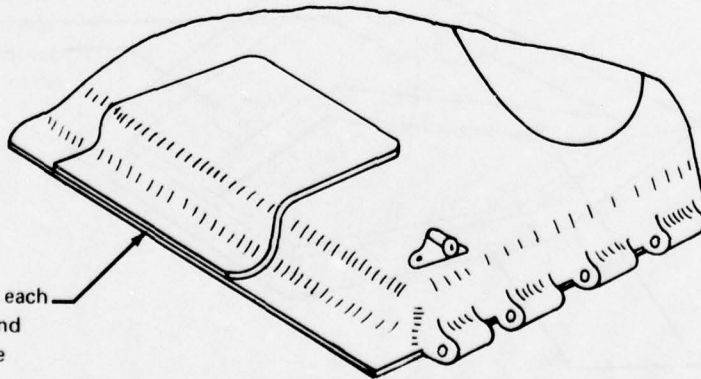
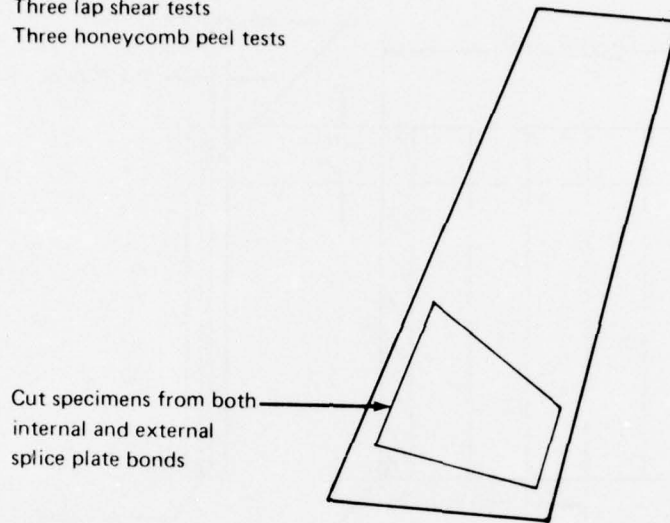

Figure 28.—Component Specimen Testing (Continued)

- (g) **A-6 Fin Panel**
Four wedge tests
Three lap shear tests
Three honeycomb peel tests



- (h) **F-111 Outboard Spoiler**
Four lap shear tests (two exposures to salt spray)
Four wedge tests

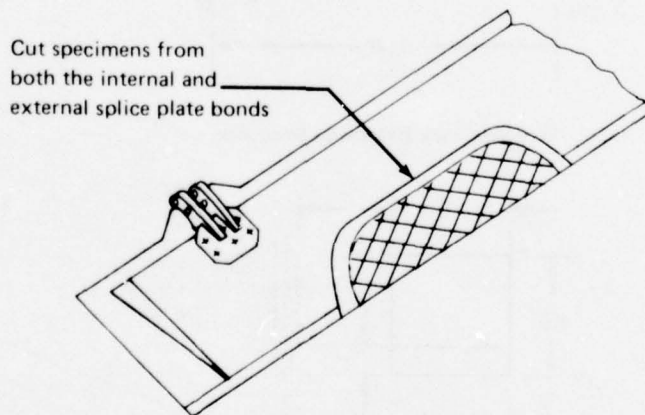
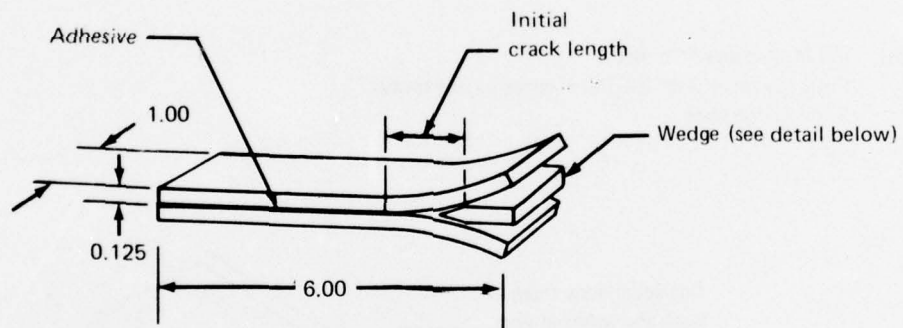
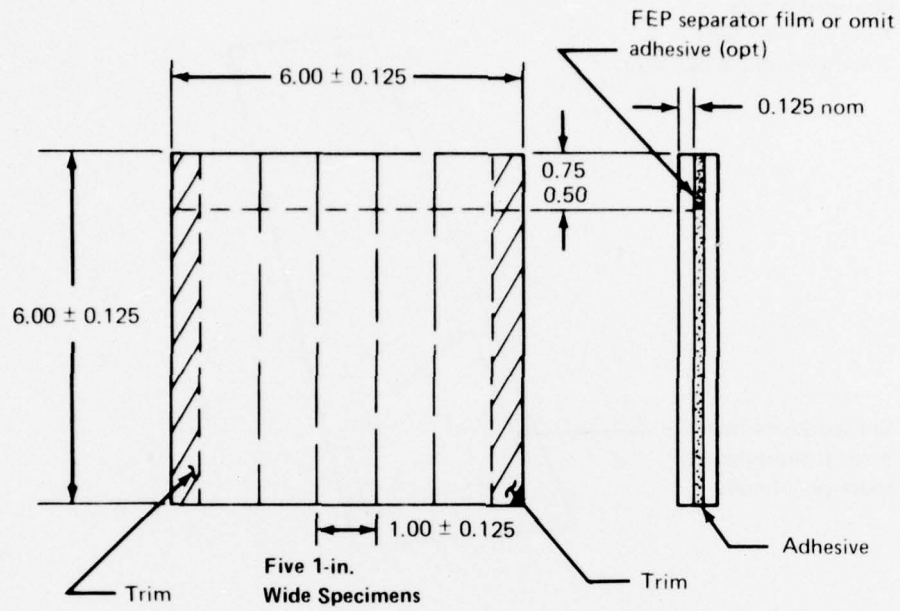

Figure 28.—Component Specimen Testing (Concluded)



Wedged Crack Extension Specimen

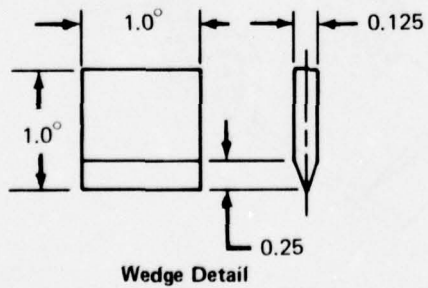

Figure 29.—Details of the Wedge Test Specimen

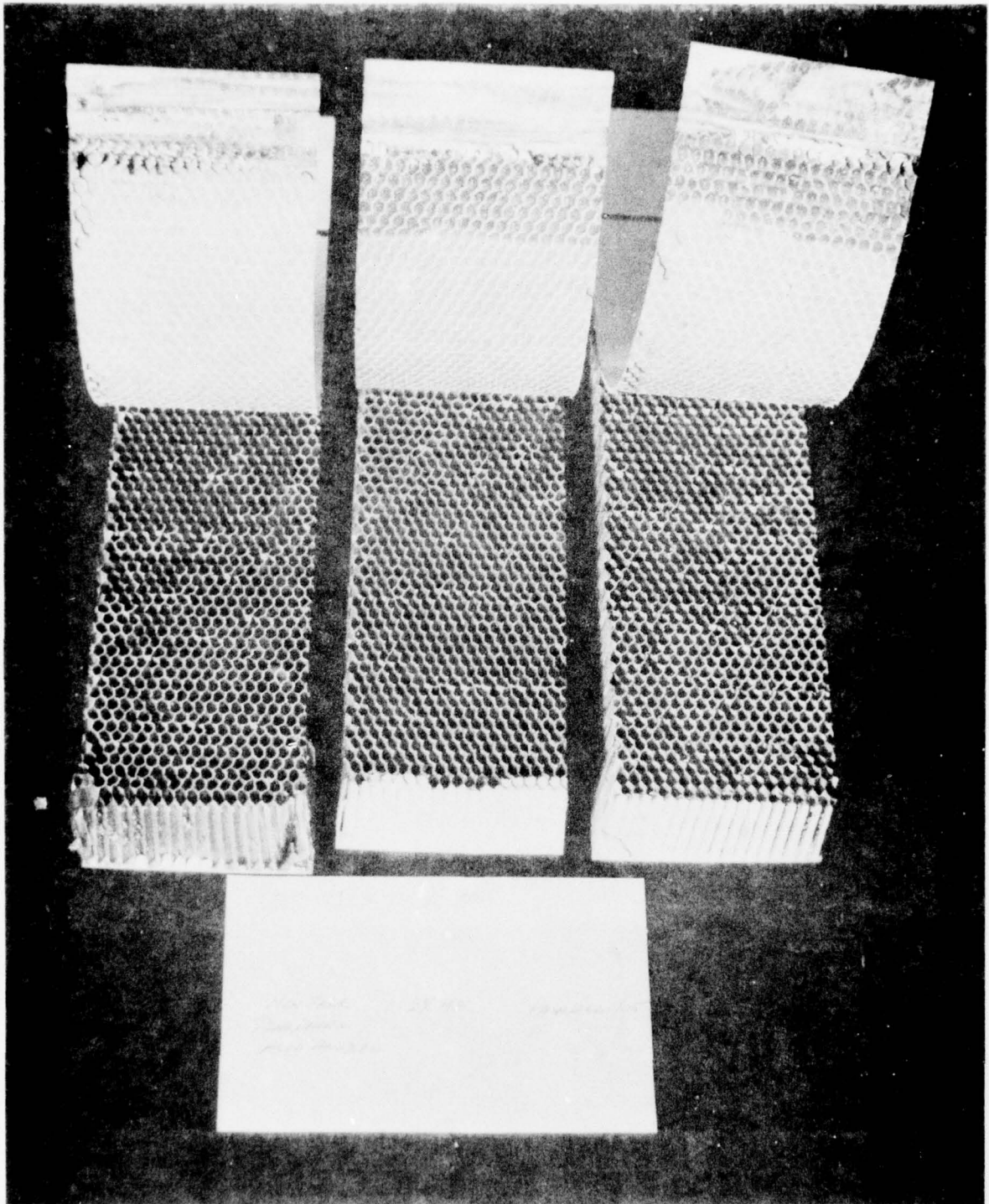

Figure 30. Honeycomb Peel Tests From the C-141 Wing L.E. Repair Showing Core Failure

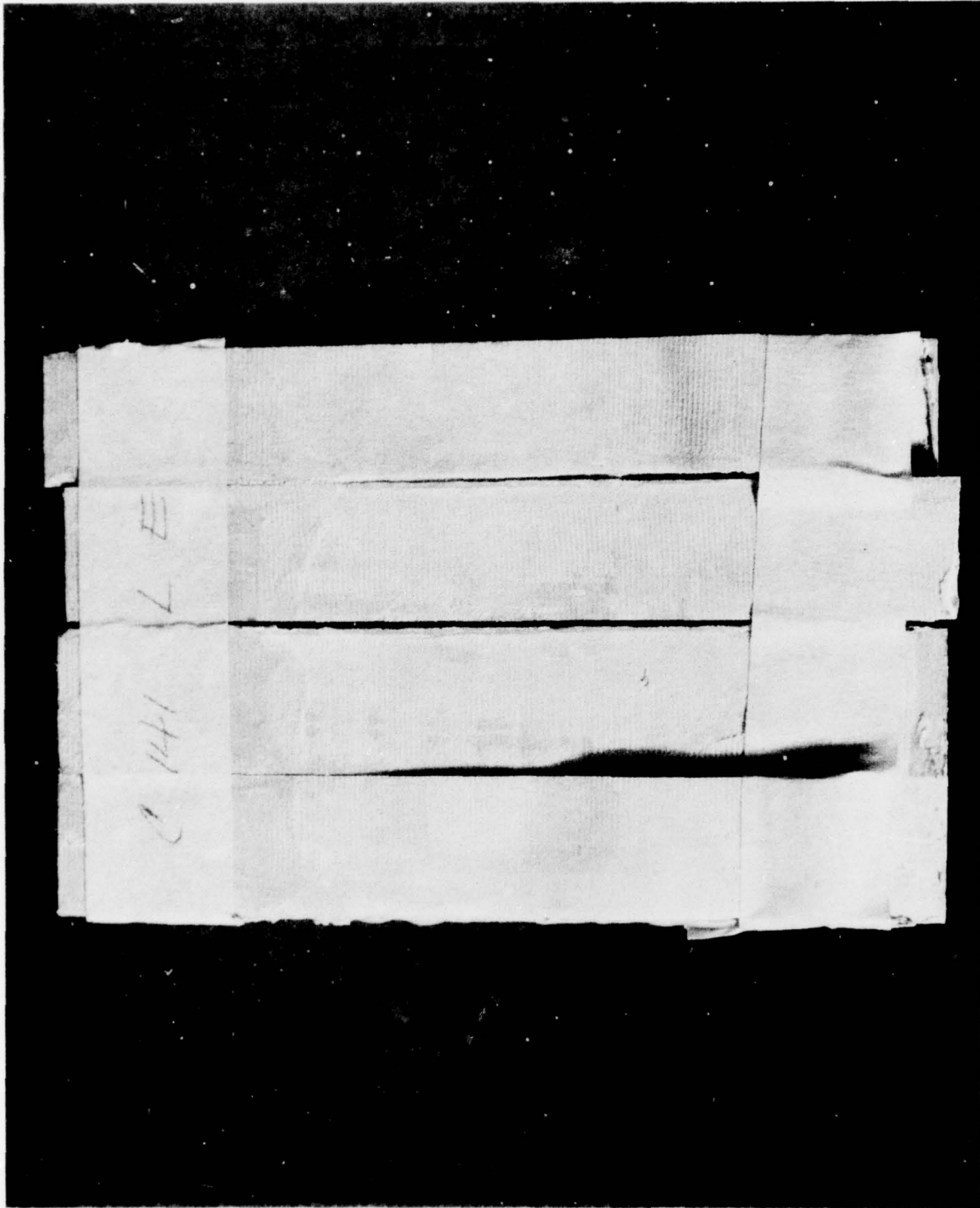

Figure 31.—Cohesive Failure Surfaces of the C-141 Wing L.E. Wedge Specimens

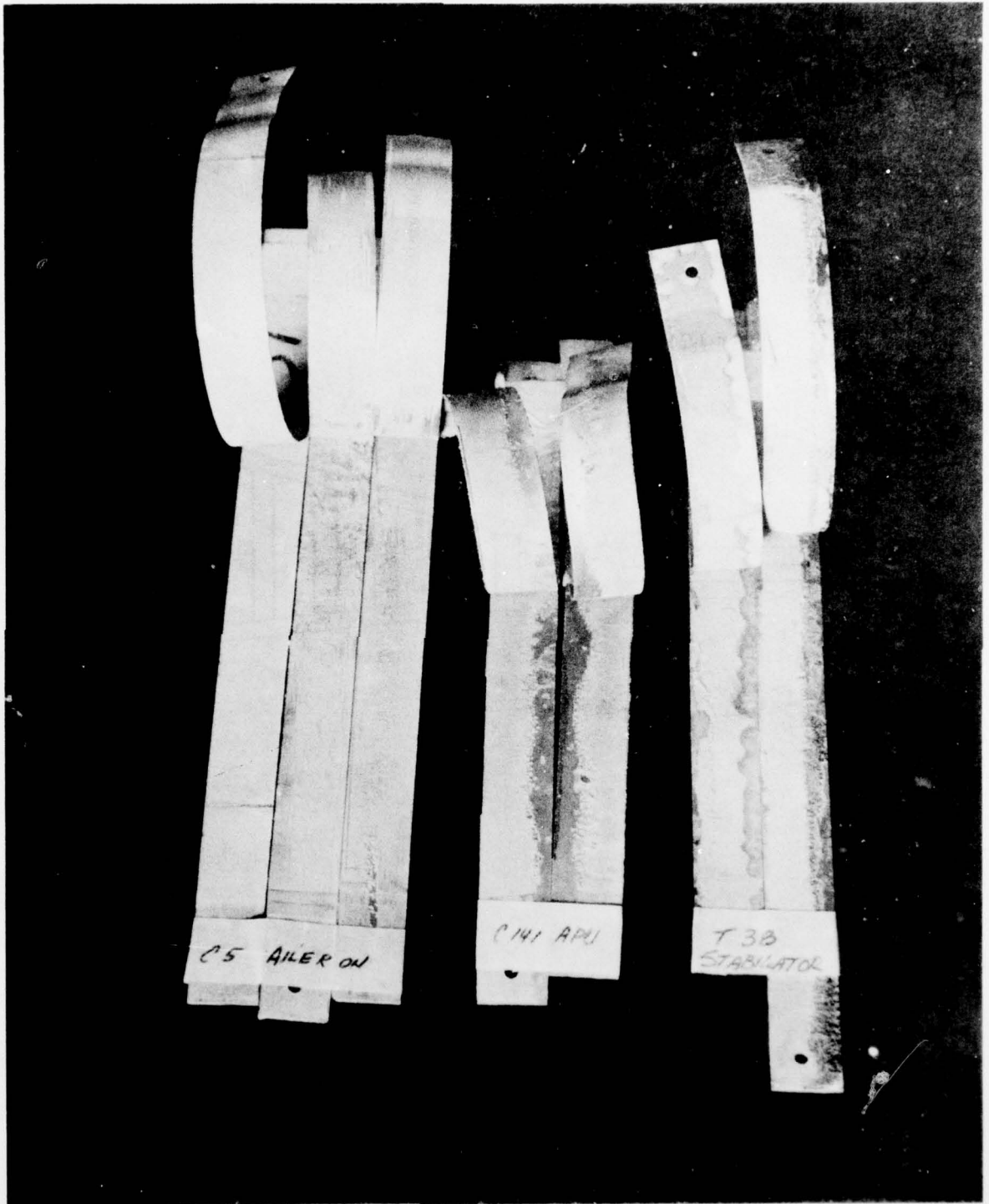

Figure 32.—Salt Spray Exposed Peel Specimens After Test

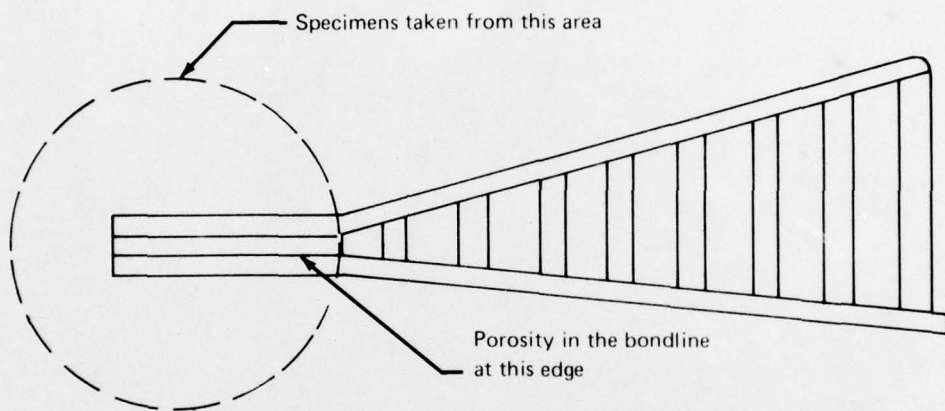

Figure 33.—Location of Bondline Porosity in the T-38 Stabilator T.E. Repair

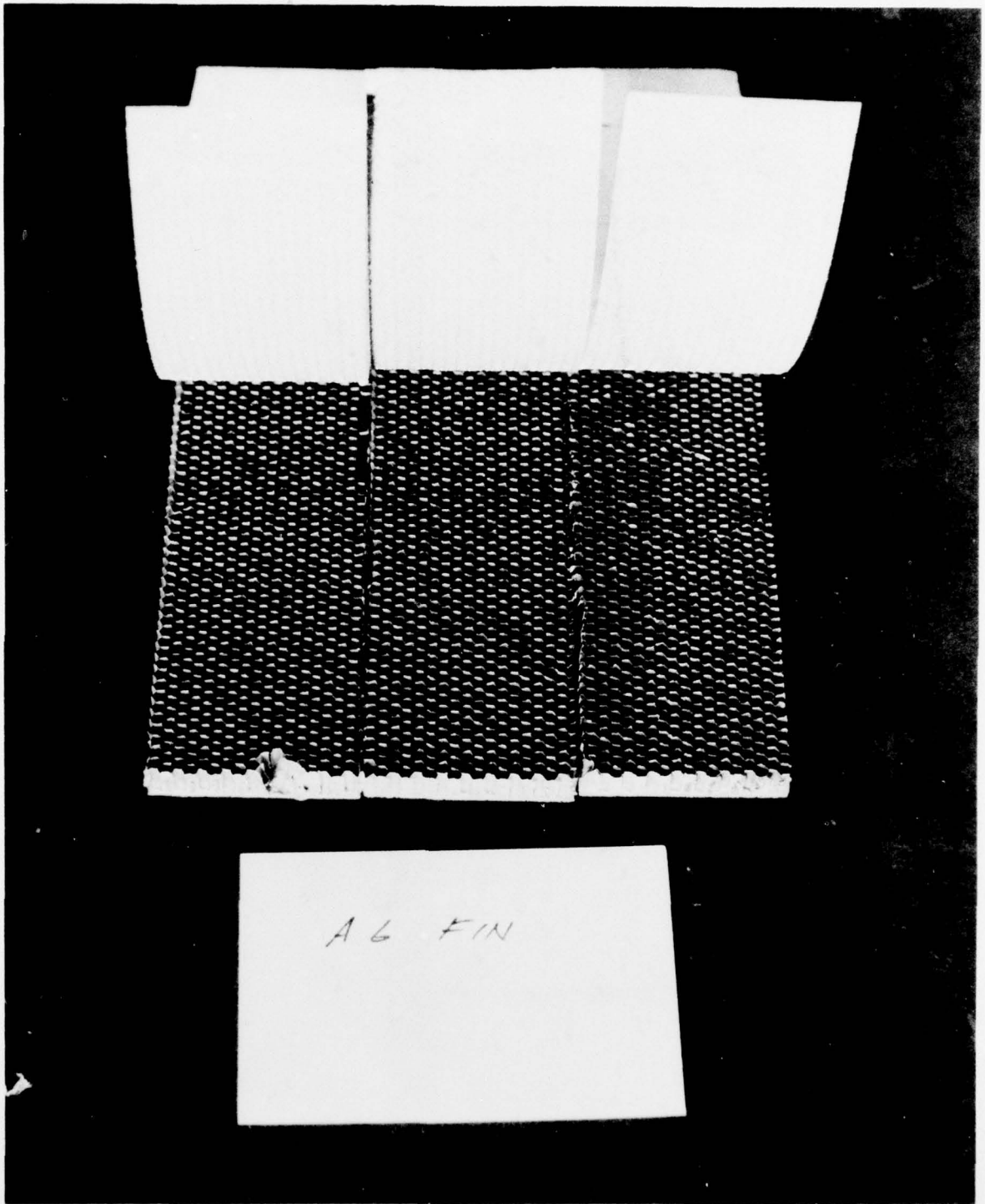

Figure 34.—Honeycomb Peel Specimens From the A-6 Fin Panel Repair Showing Core Failure

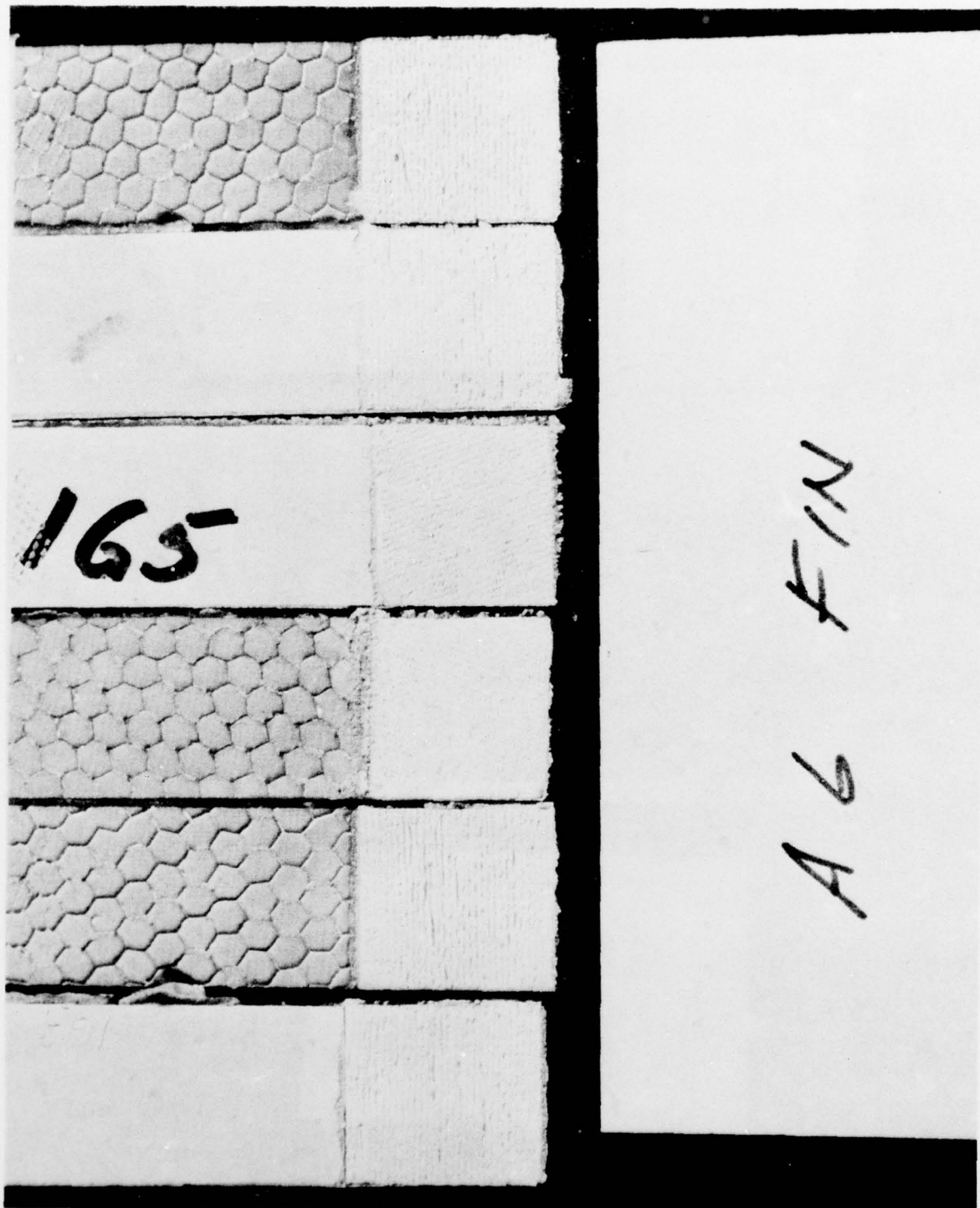

Figure 35.—Lap Shear Specimens From the A-6 Fin Panel Repair
Showing Cohesive Failure

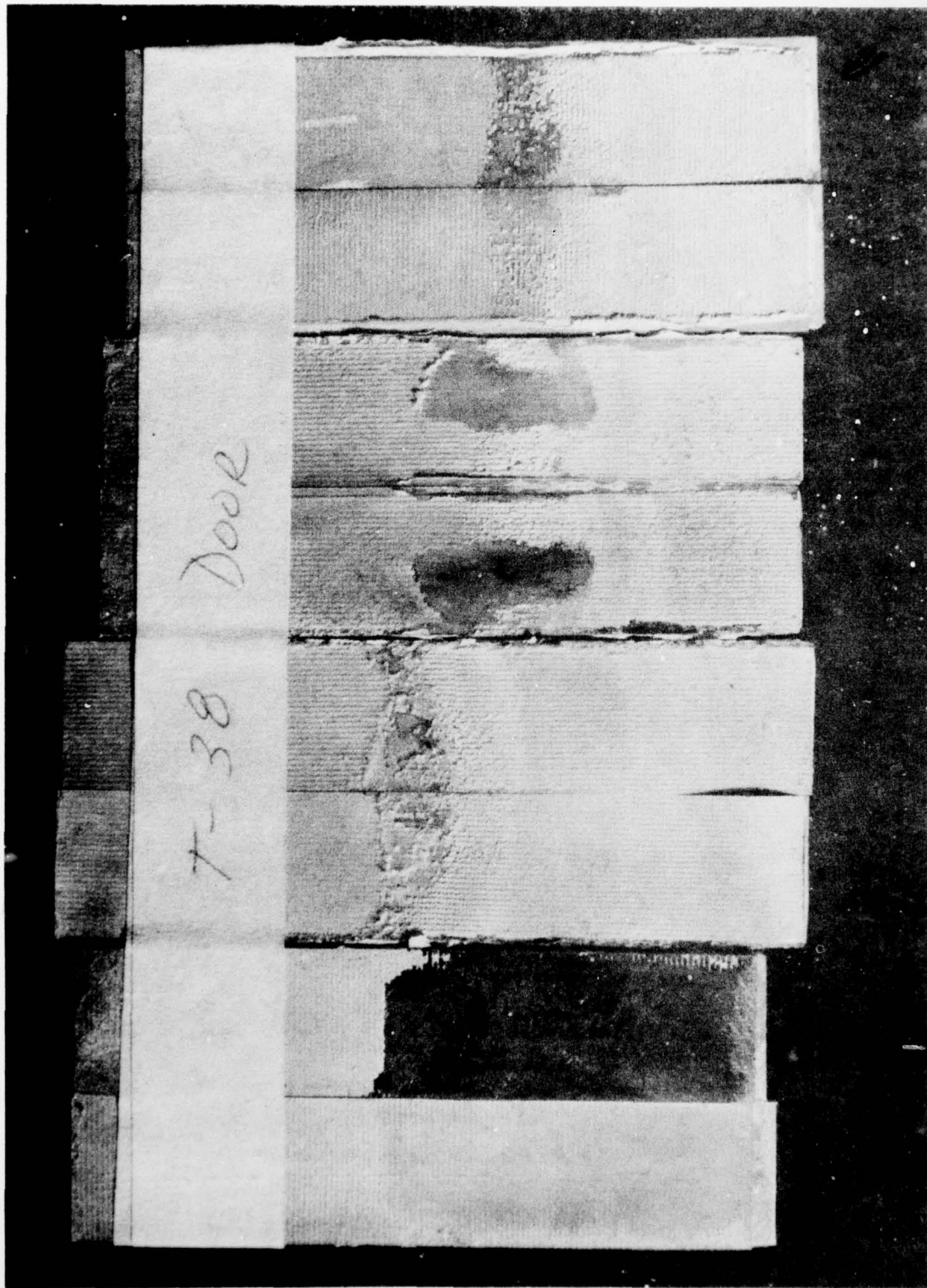

Figure 36. — Failure Surface of Wedge Specimens From the T-38 Door Repair

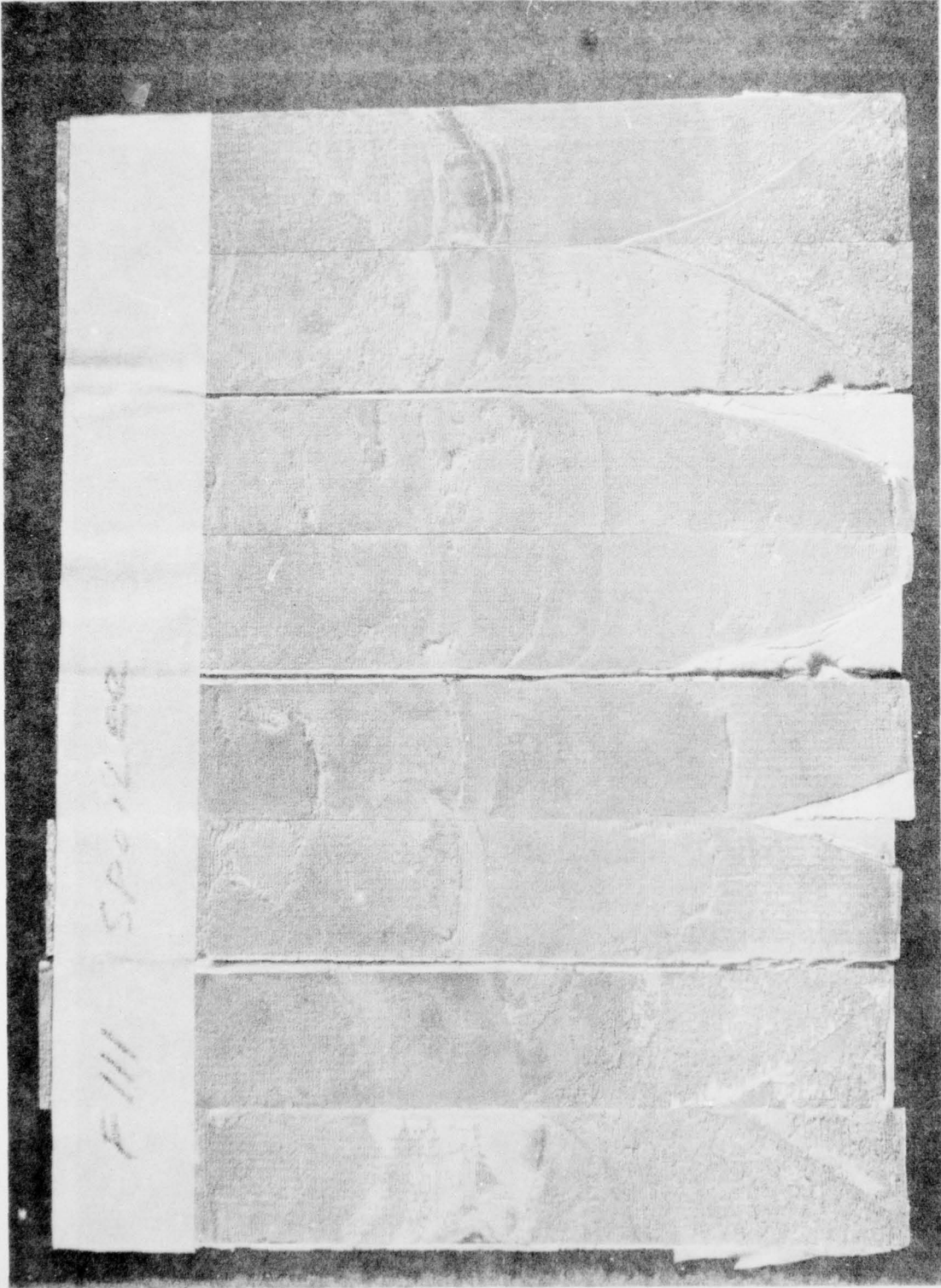

Figure 37.—Failure Surfaces of Wedge Specimens From the F-111 Spoiler

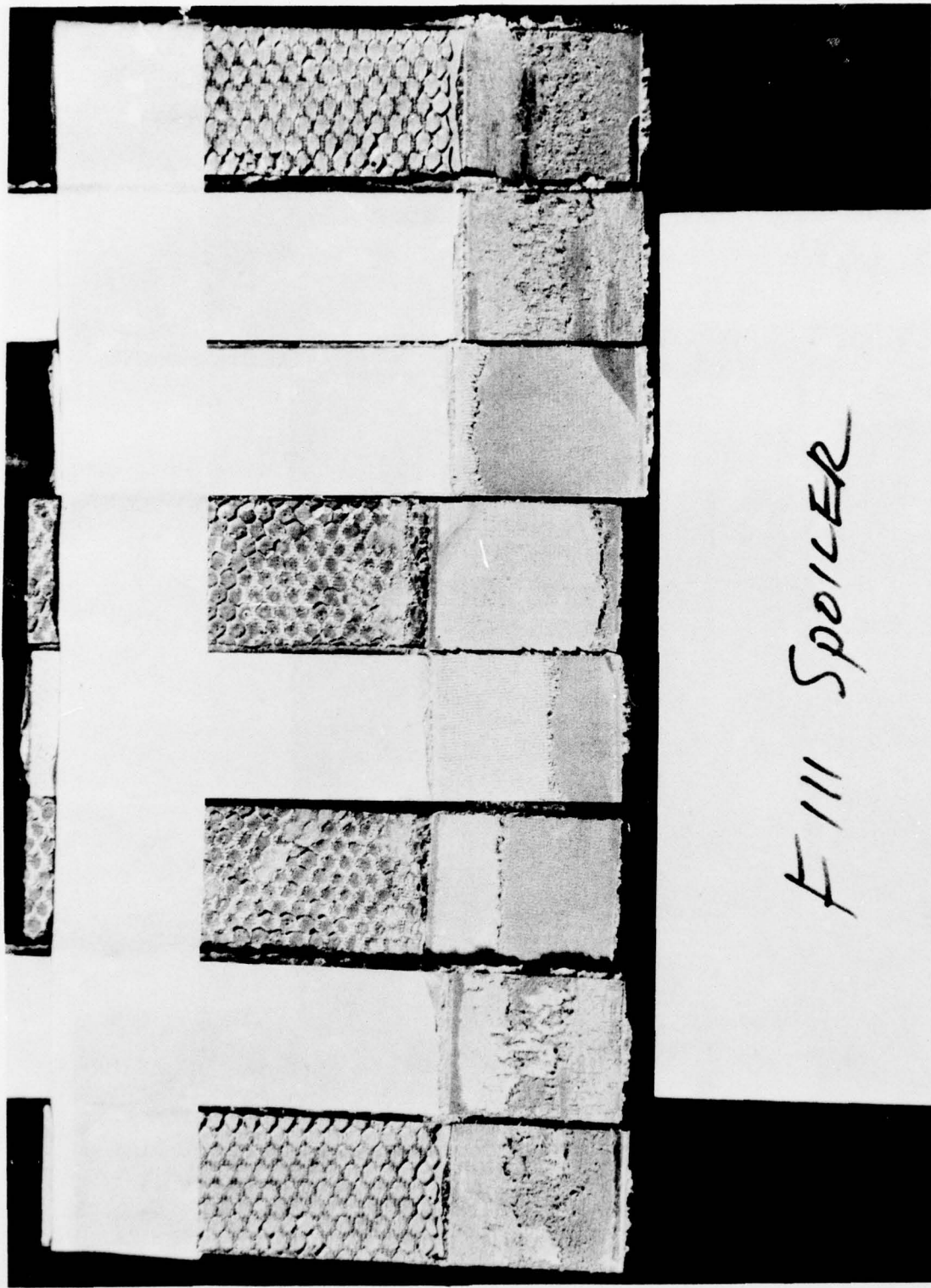

Figure 38. - Failed Lap Shear Specimens From the F-111 Spoiler Repair

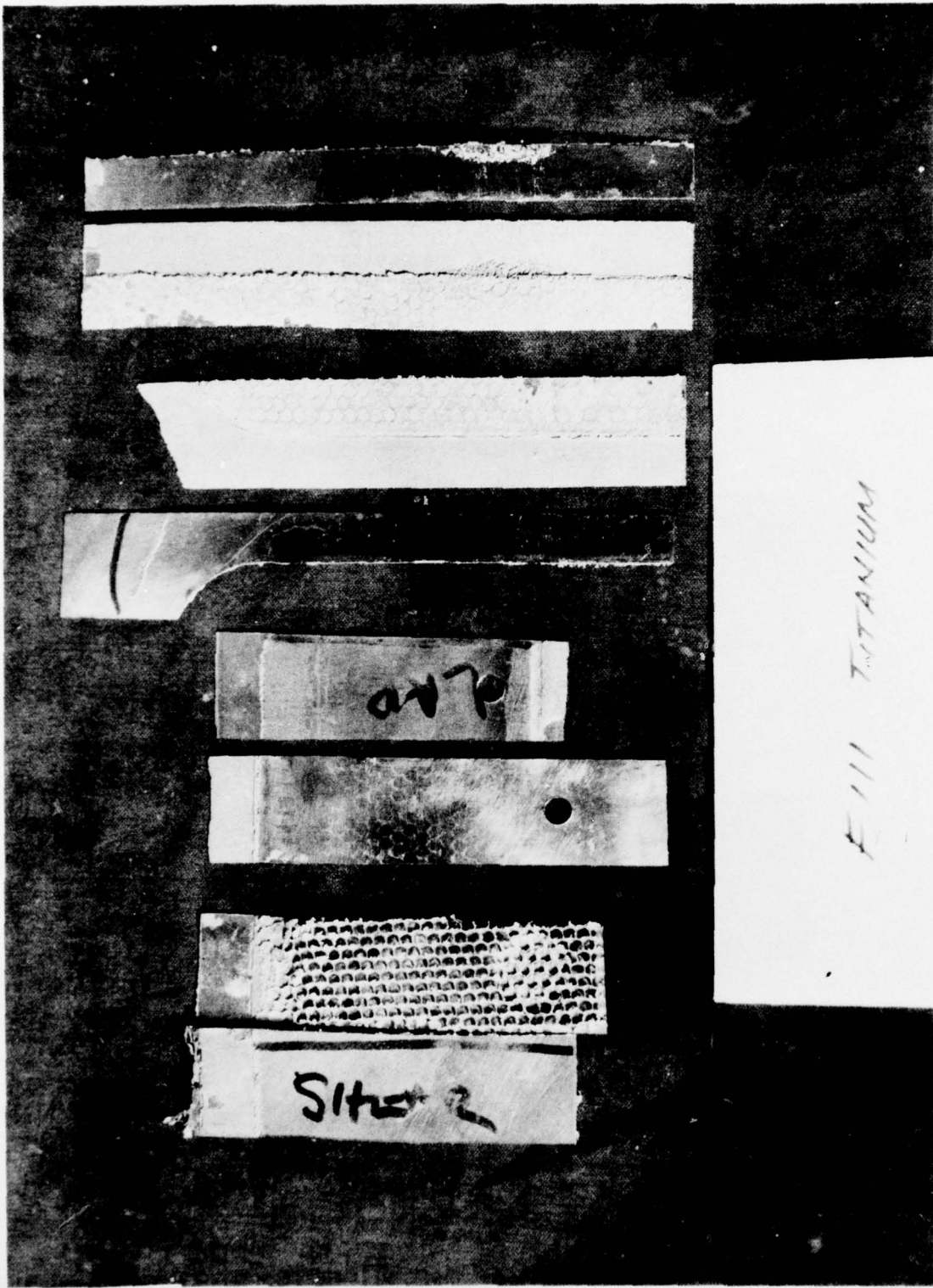

Figure 39. - Failed Lap Shear and Wedge Specimens Cut From the F-111
Titanium Fuselage Panel Repair

TABLE 1.—IDENTIFICATION OF SPOILER MATERIALS

| Identification number | Item | Material |
|-----------------------|-----------------------------------|---------------------|
| 1 | External skin, basic thickness | 0.020 2024-T81 |
| 2 | External skin, first level pad-up | 0.036 2024-T81 |
| 3 | Internal skin, basic thickness | 0.020 2024-T81 |
| 4 | Internal skin, first level pad-up | 0.036 2024-T81 |
| 5 | Core midpanel | 3.1-1/8-0.7N (5056) |
| 6 | Core pad-up area | 6.1-1/8-15N (5052) |

TABLE 2.—PROCEDURE USED TO PREPARE THE ALUMINUM SKIN SURFACES FOR BONDING

Phosphoric Acid Nontank Anodize Method

1. Solvent wipe with methylethylketone, trichloroethane or equivalent *approved* solvent
2. Abrade with Scotchbrite type A to remove surface contaminants
3. Wipe dry with clean gauze
4. Apply a uniform coat of cab-o-sil thickened phosphoric acid (10% to 12%) PR-50^a
5. Place one or two layers of gauze over the coating
6. Apply more gelled phosphoric acid over the gauze
7. Secure a piece of stainless steel wire screen^b over gauze
8. Connect screen as cathode (-) and aluminum substrate as anode (+)
9. Apply a potential of 4 to 6 volts for 10 to 12 min (current density in the range of 2 to 6 amps per square foot)
10. At the end of anodizing time, open circuit, remove screen and gauze, and lightly wipe off gelled acid coating
11. Moisten clean gauze with water, lightly wipe-rinse anodize surfaces
CAUTION: *Do not rub surface.* Test with litmus paper to ensure that all trace of acid has been removed.
12. Air dry 30-min minimum or heat dry at 160° F maximum
CAUTION: Do not touch surface with anything. Keep protected but do not wrap unless absolutely necessary.
13. Prime and bond or bond as soon as practical

^aPR-50 — gelled phosphoric acid 10% to 12% from Products Research Corporation.

^bStainless steel screen, any mesh.

TABLE 3.—RESULTS OF TESTS FROM REPAIRED AREAS OF COMPONENTS

| Part Identification | Lap shear | | Honeycomb peel | | M/M peel after 14 days salt spray, lb in./in. | Honeycomb tension flatwise, psi |
|---------------------------------|------------------------------|------------------------------|----------------------------------|---|---|---------------------------------|
| | Lap length, in. | Load, lb | Core density, lb/ft ³ | Load lb in./3 in. | | |
| C-141 simulated wing L.E. panel | | | 4.4 | 60 ^a 64 ^b 65 ^c | | |
| T-38 stabilator | | | | | 40 39 | |
| C-5 aileron | | | | | 57 51 54 | |
| F-111 titanium fuselage panel | 0.45 | 380 | | | | |
| C-141 APU access panel | | | | | 33 33 | 220 225 85 |
| T-38 main landing gear door | | | | | | |
| A-6 fin panel | 1.06 1.18 0.97 | 4020 3970 3840 | 3.1 | 30 29 29 | Core failure | |
| F-111 outboard spoiler | 1.18 1.26 1.27 1.18 | 1850 3220 3230 1810 | | | | |

^aNontank anodize surface preparation for skin.

^b2% hydrofluoric acid surface preparation for skin.

^cPasajell 105 surface preparation for skin,

TABLE 4.—WEDGE TEST DATA FROM REPAIRED AREAS OF COMPONENTS

| Part identification | Wedge test 120°F/100% RH exposure | | | | | |
|---------------------------------|---|---|------------------------------|---------------------------------|------------------------------|------------------------------|
| | Initial length, in. | Crack growth, in. | | | | |
| | | 1 hr. | 24 hr. | 72 hr. | 7 days | 14 days |
| C-141 simulated wing L.E. panel | 1.26 1.44 1.32 | Remainder of test invalid. Failure jumped to wrong surface. | | | | |
| T-38 stabilator | 1.45 1.41 | 1.07 0.09 | 1.57 0.61 | 1.72 0.64 | 1.78 0.74 | 1.86 0.88 |
| C-5A aileron | 1.53 1.58 1.26 | 0.09 0.09 0.08 | 0.31 0.28 0.28 | 0.37 0.34 0.53 | 0.44 0.34 0.53 | 0.44 0.44 0.62 |
| F-111 Titanium fuselage panel | Tests discontinued. Specimens had very low peel strength. | | | | | |
| C-141 APU access panel | 2.78 2.45 1.37 | 0.05 0.05 0.07 | 0.05 0.13 0.28 | 0.14 0.21 0.28 | 0.26 0.21 0.28 | 0.35 0.21 0.28 |
| T-38 main landing gear door | 1.63 1.59 1.67 1.63 | 0.13 0.08 2.48 0.42 | 0.41 0.24 0.52 | 0.58 0.43 Failure 0.79 | 0.63 0.54 0.84 | 0.71 0.64 0.84 |
| A-6 fin panel | 1.26 1.33 1.36 1.02 | 0.10 0.18 0.08 0.31 | 0.24 0.54 0.53 1.15 | 0.30 0.63 0.68 1.27 | 0.41 0.69 0.74 1.33 | 0.41 0.77 0.90 1.38 |
| F-111 outboard spoiler | 2.36 1.75 1.87 1.82 | 0.13 0.07 0.11 0.12 | 0.18 0.13 0.14 0.37 | 0.18 0.13 0.14 0.37 | 0.18 0.21 0.22 0.40 | 0.18 0.26 0.32 0.44 |

REFERENCES

1. General Dynamics, volume 7, report FZS-12-8165, February 1972.
2. *Structural Repair Instructions*, FB-111A Aircraft Technical Manual, T.O. 1F-111 (b) A-3, 9 May 1969.
3. *Structural Aluminum Design*, Reynolds Metals Company, 1965.
4. *Adhesive Bonded Aerospace Structures Standardized Repair Handbook: Phase II*, report, AFML-TR-75-158, August 1975.
5. General Dynamics, *Spoilers, Inboard and Outboard, Open Position Ultimate Load Static Test Static Test Airplane (A3) Test Results*, F-111A/B Program, report 12A6169, Addendum I, 16 June 1969.
6. General Dynamics, *F-111A 100% Flight Loads Program Results*, volume IV, Report FZS-12-1039, Addendum I, 1 December 1972.
7. General Dynamics, part II, report FZS-12-100, volume 1, 6 June 1966.
8. *Static Testing of F-111 Outboard Spoiler*, Boeing test report T6-5918 No. 1, 26 April 1976
9. *Adhesive Bonded Aerospace Structures Standardized Repair Handbook: Phase III*, report AFML-TR-76-65, May 1976.