

AD-A042 391

OHIO STATE UNIV COLUMBUS ELECTROSCIENCE LAB
STIMULATED RAMAN SCATTERING IN METHANE WITH ND: YAG PUMP.(U)
JUN 77 J G MEADORS, M A POIRIER

F/G 20/6

DAAG29-76-G-0140

UNCLASSIFIED

ESL-4297-1

NL

1 of 1
ADA042391



END

DATE
FILMED
8 - 77



(Final Report)
STIMULATED RAMAN SCATTERING IN METHANE WITH Nd:YAG PUMP

J. G. Meadors
M. A. Poirier

12

[Handwritten signature]

ADA 042391

The Ohio State University
ElectroScience Laboratory

Department of Electrical Engineering
Columbus, Ohio 43212

FINAL TECHNICAL REPORT 4297-1

Contract DAAG29-76-G-0140

June 1977

DDC
RECEIVED
AUG 1 1977
[Handwritten signature]

AD No. ~~1~~
DDC FILE COPY

Department of the Army
U. S. Army Research Office
P.O. Box 12211, Research Triangle Park
North Carolina 27709

NOTICES

When Government drawings, specifications, or other data are used for any purpose other than in connection with a definitely related Government procurement operation, the United States Government thereby incurs no responsibility nor any obligation whatsoever, and the fact that the Government may have formulated, furnished, or in any way supplied the said drawings, specifications, or other data, is not to be regarded by implication or otherwise as in any manner licensing the holder or any other person or corporation, or conveying any rights or permission to manufacture, use, or sell any patented invention that may in any way be related thereto.

13988. 1-PX + 11680. 1-P

STIMULATED RAMAN SCATTERING IN METHANE WITH Nd: YAG PUMP

J. G. Meadors
M. A. Poirier

This research was supported by the following U. S. Army
Research Office Grants: DAAG29 76 G 0140
DAHCO4 74 G 0098
DAAG29 76 G 0030

Approved for public release; distribution unlimited.

THE FINDINGS IN THIS REPORT ARE NOT TO BE CONSTRUED AS AN
OFFICIAL DEPARTMENT OF THE ARMY POSITION, UNLESS SO
DESIGNATED BY OTHER AUTHORIZED DOCUMENTS.

FINAL TECHNICAL REPORT

June 1977

The Ohio State University
Electroscience Laboratory
Department of Electrical Engineering
Columbus, Ohio 43212

file cy

UNCLASSIFIED

SECURITY CLASSIFICATION OF THIS PAGE (When Data Entered)

| REPORT DOCUMENTATION PAGE | | READ INSTRUCTIONS BEFORE COMPLETING FORM |
|---|----------------------|--|
| 1 REPORT NUMBER | 2 GOVT ACCESSION NO. | 3 RECIPIENT'S CATALOG NUMBER |
| 4 TITLE (and Subtitle) | | 5 TYPE OF REPORT & PERIOD COVERED |
| ⑥ STIMULATED RAMAN SCATTERING IN METHANE WITH Nd:YAG PUMP | | ⑨ Final Technical Report |
| 7 AUTHOR(s) | | 6 PERFORMING ORG. REPORT NUMBER |
| ⑩ J. G. Meadors M. A. Poirier | | ⑭ ESL-4297-1 |
| 8 PERFORMING ORGANIZATION NAME AND ADDRESS | | 9 CONTRACT OR GRANT NUMBER(s) |
| The Ohio State University ElectroScience Laboratory, Department of Electrical Engineering, Columbus, Ohio, 43212 | | ⑮ Contract DAAG29-76-G-0140 |
| 11 CONTROLLING OFFICE NAME AND ADDRESS | | 10 PROGRAM ELEMENT, PROJECT, TASK AREA & WORK UNIT NUMBERS |
| Dept. of the Army, U.S. Army Research Office P.O. Box 12211, Research Triangle Park North Carolina 27709 | | ⑪ DAAG29-74-G-0098 |
| 14 MONITORING AGENCY NAME & ADDRESS (if different from Controlling Office) | | 12 REPORT DATE |
| ⑫ 27p. | | ⑪ June 1977 |
| 16 DISTRIBUTION STATEMENT (of this Report) | | 13 NUMBER OF PAGES |
| DISTRIBUTION STATEMENT A Approved for public release; Distribution Unlimited | | 21 |
| 17 DISTRIBUTION STATEMENT (of the abstract entered in Block 20, if different from Report) | | 15 SECURITY CLASS. (of this report) |
| | | Unclassified |
| 18 SUPPLEMENTARY NOTES | | 15a DECLASSIFICATION DOWNGRADING SCHEDULE |
| | | |
| 19 KEY WORDS (Continue on reverse side if necessary and identify by block number) | | |
| Stimulated Raman Scattering Near Infrared Coherent Source Eyesafe Laser | | |
| 20 ABSTRACT (Continue on reverse side if necessary and identify by block number) | | |
| The results of an experimental study of stimulated Raman scattering in methane pumped by a repetitively Q-switched Nd:YAG laser are presented and discussed. Three compact geometrical arrangements were investigated: (1) Raman cell external to the laser cavity with focusing and recollimating optics, (2) Raman cell external to cavity with pump beam coupled into a leaky waveguide (pyrex capillary) immersed in high pressure methane, and (3) Raman cell positioned → next page | | |

DD FORM 1473 1 JAN 73

EDITION OF 1 NOV 65 IS OBSOLETE

UNCLASSIFIED

SECURITY CLASSIFICATION OF THIS PAGE (When Data Entered)

402 251

15

20.

micrometers

cont → internal to laser cavity. In configurations (1) and (2), photon conversion efficiencies from 1.06 μm to 1.54 μm of 15% to 20% were observed with good amplitude stability if proper attention is given to laser adjustment. These results are based on direct measurements of the various signals; pump depletion measurements can not be used to infer energy conversion from pump to Stokes unless care is taken to eliminate pump backscatter. Configuration (3) produced 6.8 millijoule Stokes pulses of 8 nanosecond total width between half power points with remarkable amplitude and shape stability. With careful engineering this basic configuration would be feasible for designing a 1.54 μm rangefinder or illuminator.

ACKNOWLEDGMENTS

The authors wish to acknowledge numerous discussions with Mr. William C. Beattie* concerning stimulated Raman scattering in methane. He shared and compared his experimental data with ours at critical times in this study and, in addition, provided advice and material support during the entire course of this work.

ACCESSION for

RTIS White Section

DSC Buff Section

UNANNOUNCED

JUSTIFICATION *Per*

Dr. Beattie

BY

DISTRIBUTION/AVAILABILITY CODES

| Dist. | AVAIL. | and/or SPECIAL |
|----------|--------|----------------|
| <i>A</i> | | |

*Mr. Beattie is with Department of the Army, CS/TA CT-L-C, Fort Monmouth, New Jersey.

TABLE OF CONTENTS

| | Page |
|--|------|
| I. INTRODUCTION | 1 |
| II. STIMULATED RAMAN SCATTERING (SRS) IN METHANE (EXTERNAL TO LASER CAVITY) | 2 |
| A. Stokes Generation with Competing Nonlinear Effects | 2 |
| B. Stokes Generation with Pump Backscatter Eliminated | 8 |
| III. SRS IN CAPILLARY GEOMETRY | 13 |
| IV. SRS WITH METHANE CELL INTERNAL TO LASER CAVITY | 16 |
| A. Ohio State University Work | 16 |
| B. Ft. Monmouth Work on Raman Designator | 16 |
| V. SUMMARY AND CONCLUSIONS | 19 |
| REFERENCES | 21 |

STIMULATED RAMAN SCATTERING IN METHANE WITH Nd:YAG PUMP

I. INTRODUCTION

This report describes an experimental investigation of the practical feasibility of obtaining efficient energy conversion from $1.06\mu\text{m}$ to $1.54\mu\text{m}$ via stimulated Raman scattering in methane in a compact lightweight cell. Ruggedized, portable Nd:YAG rangefinders are available commercially for operation at $1.06\mu\text{m}$; however, for some applications, it would be beneficial to shift the wavelength of operation of the rangefinder to the region near $1.5\mu\text{m}$. Previous work has shown methane to be an efficient Raman scatterer that downconverts $1.06\mu\text{m}$ to $1.54\mu\text{m}$ radiation with a photon conversion efficiency of 15% to 22% [1,2,3,4]. The main thrust of this program was therefore directed to the study of stimulated Raman scattering in methane in simple, compact geometries for use inside or outside the laser cavity. The study concentrated on three basic experimental layouts: (1) the methane gas cell located external to the laser cavity with focusing and recollimating lenses on the ends, (2) a hollow dielectric waveguide placed inside the high pressure gas cell external to the laser cavity with a positive lens used to couple the pump radiation into the leaky waveguide, and (3) a methane gas cell with optics placed inside the laser cavity formed by two flat mirrors. The presentation and interpretation of the results of these experiments and their application to the design of a $1.54\mu\text{m}$ coherent source for use as a rangefinder constitute the essence of this report.

Experiments were performed with a repetitively Q-switched Nd:YAG laser manufactured by International Laser Systems (Model NT114) as the optical pump after some remodeling. During the course of our experimentation, two distinct, stable regimes of energy conversion through stimulated Raman scattering were reproducibly observed by merely fine tuning the laser output mirror. During this adjustment the only observable effect in the output pulse was a slight change in the pulse risetime with no change in peak power as monitored in the current output of a biplanar vacuum photodiode of two inches diameter. In the regime of lower Raman conversion, it was found that a significant fraction of the pump beam was backscattered from the interaction volume; by fine tuning the laser output mirror, the peak power in the Raman shifted beam was increased by a factor 4 to 5 with little or no backscatter of either the pump or Raman shifted beam. Available equipment for monitoring the laser output did not allow us to quantify the detailed change in the mode structure of the laser by slight adjustments in the alignment of the output mirror.

II. STIMULATED RAMAN SCATTERING IN METHANE EXTERNAL TO LASER CAVITY

A high pressure cell external to the laser cavity was used in our first Raman experiment. A 30 cm long stainless steel high pressure cell with half inch thick fused silica windows on each end was used to contain the methane gas. A pair of 30 cm focusing and recollimating lenses were placed around the Raman cell. Input and output powers were measured both through (transmitted) and in front of (backscattered) the Raman cell with vacuum biplanar photodiodes of two inches diameter as well as fast silicon and germanium photodiodes. See Figure 1 for experimental layout. Energy measurements were also made for the same locations using thermopiles which are schematically depicted in Figure 2.

A. Stokes Generation with Competing Nonlinear Effects

Peak power measurements indicated a significant percentage of the laser power backscattered from the interaction volume of the Raman cell; energy measurements at points indicated in Figure 2 confirmed these observations. Measurements were made of the pump power at $1.06\mu\text{m}$ transmitted (position 3, Figure 1) and backscattered by the Raman cell (position 2, Figure 1) as the methane pressure was varied from 0 psi to 1000 psi. Table 1 shows a summary of these measurements when 30 cm focusing and recollimating lenses were used as well as the Stokes peak power detected at position 3 in Figure 1.

TABLE I

Itemized values for the peak powers in the transmitted and backscattered pump beam as well as the peak Stokes power for various pressures of methane. Detector positions refer to Figure 1.

| Detector Position and Wave- length Methane Pressure (Psi) | $1.06\mu\text{m}$ (Position 3) Transmitted Power (MW) | $1.06\mu\text{m}$ (Position 2) Backscattered Power (MW) | $1.54\mu\text{m}$ (Position 3) Stokes Power (KW) |
|---|--|--|---|
| 0 | 3 | .5 | 0 |
| 300 | 2.6 | .6 | 0 |
| 400 | 2.2 | up to 1.3 | 29 |
| 600 | 1.5 | 1.6 | 60 |
| 800 | 1.2 | 1.8 | 75 |
| 1000 | 1.0 | 2.1 | 90 |

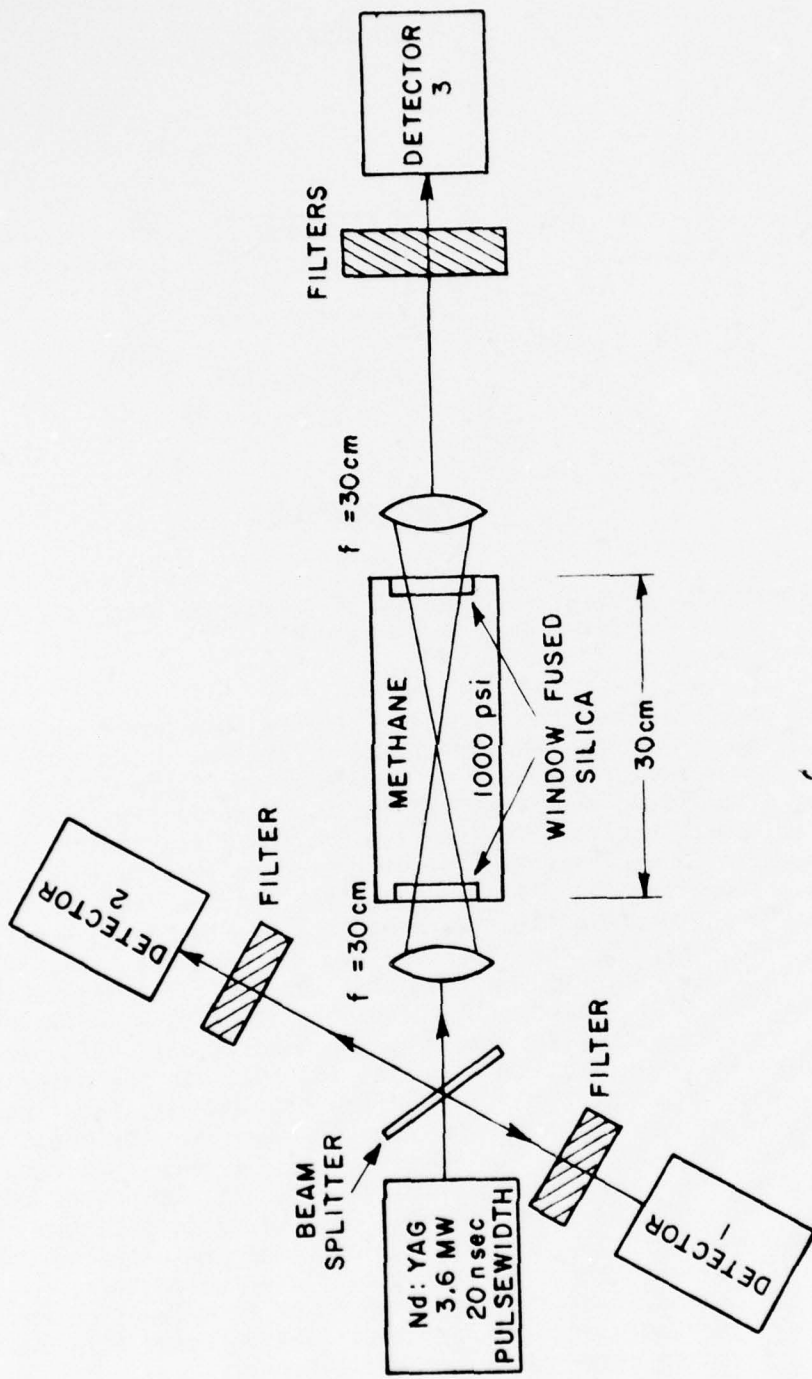

Figure 1. Experimental layout for the study of stimulated Raman scattering in methane external to laser cavity.

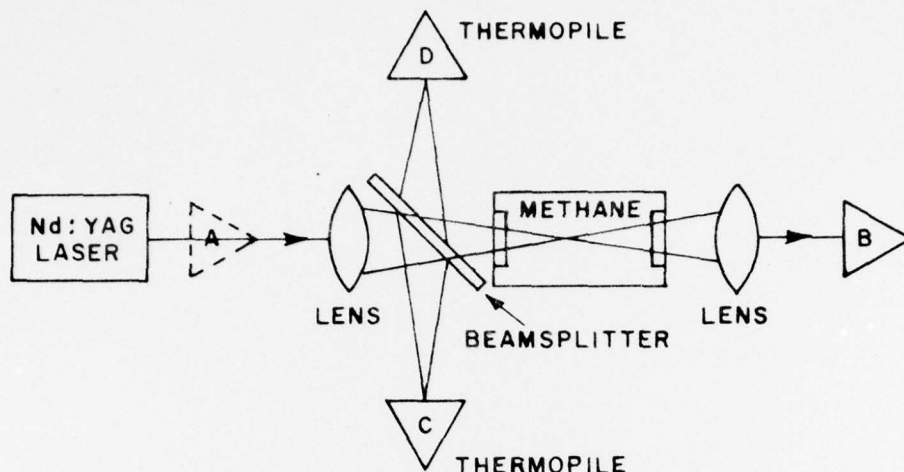
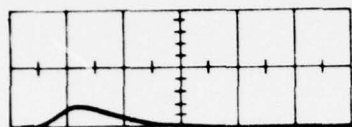
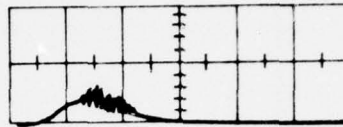

Figure 2. Optical arrangement of energy sensors to study energy in Raman cell.

The temporal behavior of the backscattered pump power suggested that a competing nonlinear effect might be occurring in the interaction volume. By examining the sequence of waveforms in Figure 3, the existence of a threshold and transient buildup time is suggested. We attributed this backscatter to stimulated Brillouin scattering (SBS) even though detailed experimental investigation to justify this conclusion was not performed. For our objectives, this effect was detrimental and therefore efforts were made to eliminate its occurrence. By delicate adjustments to the laser cavity, the enhanced backscatter disappeared, and with this accomplishment a substantial increase in Stokes generation was realized. In the next section this regime of operation is discussed, but for now we present additional information on the features of Stimulated Raman Scattering (SRS) in the presence of significant pump backscatter. From these measurements for fixed laser parameters it was found that powers and energies attributed to both SRS and SBS were pressure dependent. Pressure threshold for stimulated Raman scattering was measured to be about 400 psi of methane for 3.6 MW pulses at $1.06\mu\text{m}$ with 20 nsec pulse width (see Figure 4). Pressure threshold for stimulated Brillouin scattering was also found to be about 400 psi of methane for identical laser parameters. Figure 5 shows the peak backscattered pump power as a function of pressure. Near threshold the initiation of backscattered pump occurs later in time than the onset of Stokes generation.



PRESSURE: 0 → 300psi



400 psi

(NOTE BACKSCATTER IS ENHANCED IN ONLY SOME OF THE PULSES)



600 psi



1000 psi

Figure 3. Temporal behavior of the backscattered power in 1.06 μ m beam at different pressures. Detector located at position 2 in Figure 1. Each oscillogram shows about 20 pulses superimposed.

Horizontal Scale: 10 $\frac{\text{nanoseconds}}{\text{div.}}$

Vertical Scale: 1.2 $\frac{\text{MW}}{\text{div.}}$

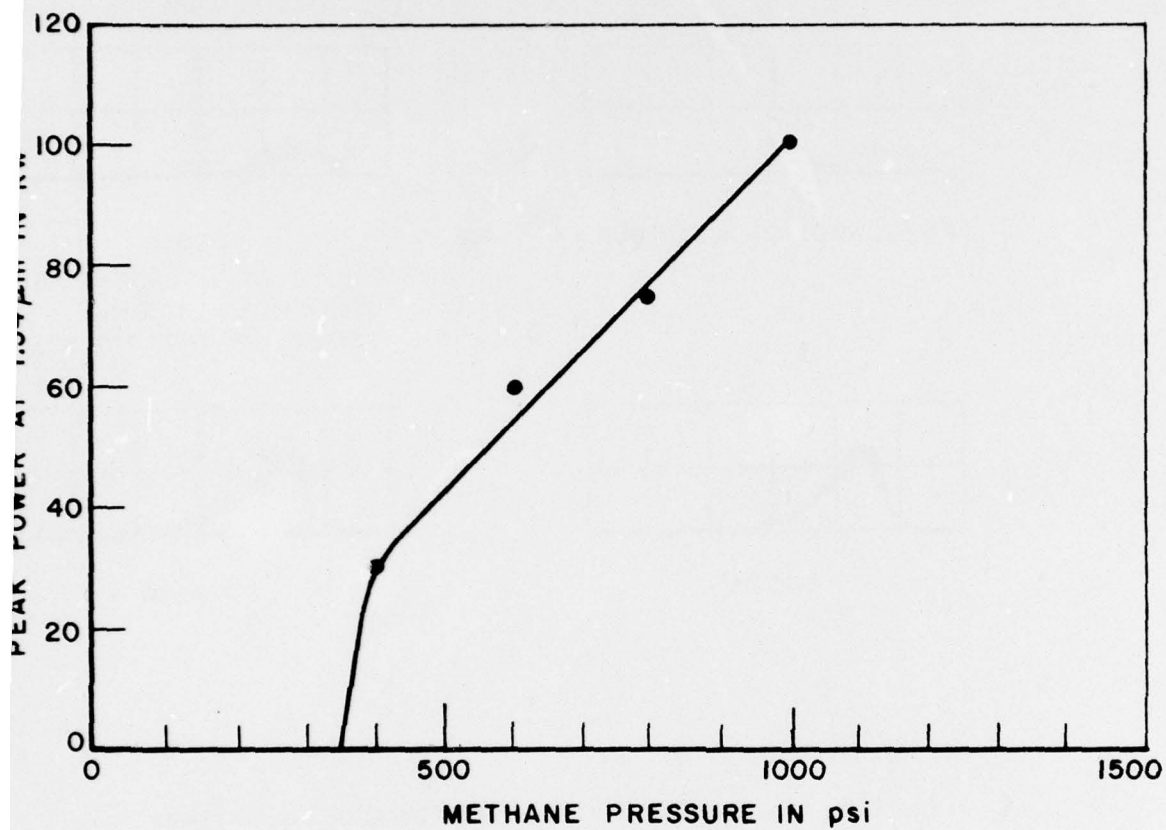

Figure 4. Raman power at 1.54 μ m vs. methane pressure for the layout shown in Figure 1.

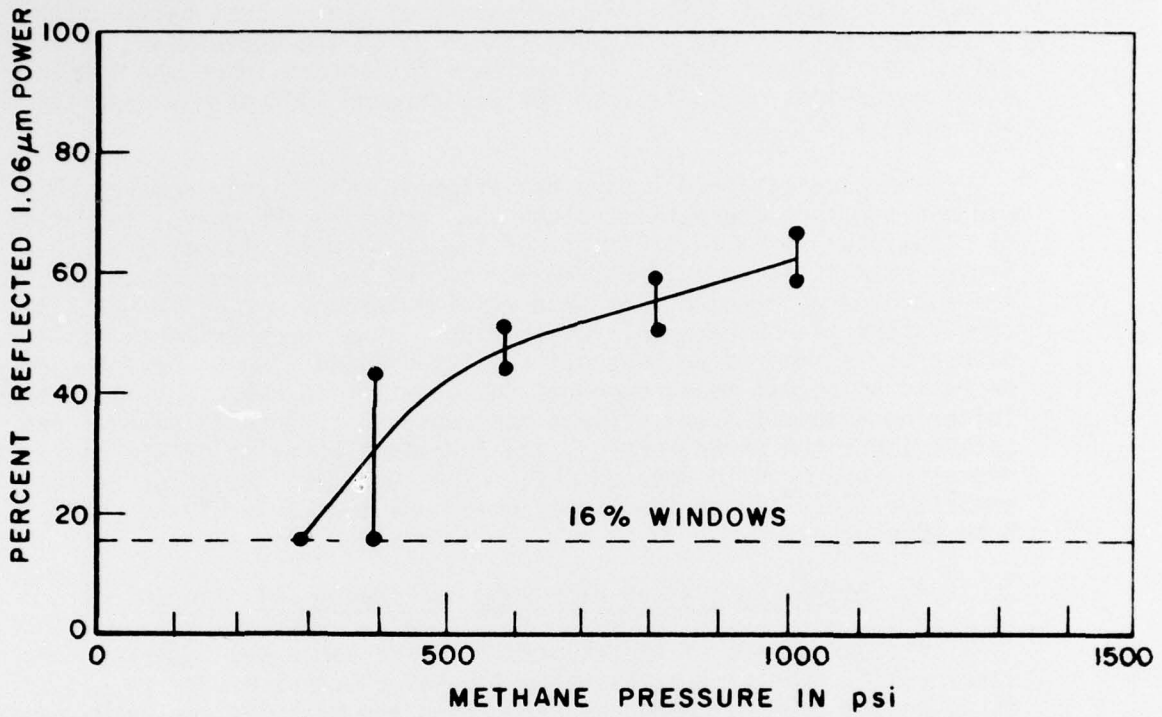

Figure 5. Backscattered pump power vs. methane pressure for conditions depicted in Figure 1.

For methane pressures of 1000 psi the photon conversion efficiency from 1.06 μ m to 1.54 μ m was measured to be approximately 14% of the transmitted pump photons in the presence of significant backscatter; or referenced to empty cell pump transmission the conversion efficiency is about 4.5%. Conversion efficiencies increased linearly with methane gas pressure from 400 psi through 1000 psi as depicted in Figure 6.

The backscattered 1.06 μ m radiation is effectively removed pump energy from the interaction volume thus reducing the energy conversion by stimulated Raman scattering. If the conversion of energy to the Stokes beam is to be inferred by monitoring the pump depletion or the pump energy removed upon transmission through the Raman gas, the conclusions can be extremely misleading. Thus in experiments of this nature it is imperative that all results dealing with power and energy be based on actual measurement of the quantity in question rather than inferring a result from indirect observation. Even with significant backscatter, the power, energy, and transient behavior of the scattering processes were quite reproducible. The long term deviation in the amplitude stability of the Stokes pulse was typically of the order 5 to 10 percent.

B. Stokes Generation With Pump Backscatter Eliminated

A second phase of experiments with the Raman cell outside the laser cavity consisted of aligning the laser output mirror to minimize the backscattered pump radiation and maximize the laser power conversion by SRS to the first Stokes line at 1.54 μ m. Slight alignment of the laser mirrors did not noticeably change the peak power of the laser pulse or its pulse width; however, this adjustment procedure does dramatically affect the Stokes generation in the methane. With very slight adjustments on the laser cavity alignment, the Stokes output power at 1.54 μ m from methane at 1400 psi was varied from zero up to 400 KW with no observable change in the laser peak power as monitored by a biplanar vacuum photo diode (S-1 surface). The 400 KW peak power Stokes pulses were found to be stable in both pulsewidth and amplitude. Measurement of the 1.06 μ m radiation through the Raman cell clearly indicated a large pump depletion. While operating with maximum Stokes peak power, energy measurements confirmed the absence of backscattered pump radiation from the interaction volume. The measured energy conversion efficiencies for methane at 1500 psi was again about 16% of the transmitted 1.06 μ m energy in the absence of SRS (empty cell transmission). Figure 7 shows the depleted pump pulse and the Stokes pulse generated when 57 cm and 30 cm focal length lenses were used to focus the pump into methane at a pressure of 1400 psi. Energy conversion efficiencies may be determined graphically from these waveforms. Figure 8 shows the Stokes peak power as a function of methane gas pressure for these two different focusing lenses. The 1.54 μ m energy measured by a thermopile at 1400 psi methane for the two different lens systems confirms the photon conversion

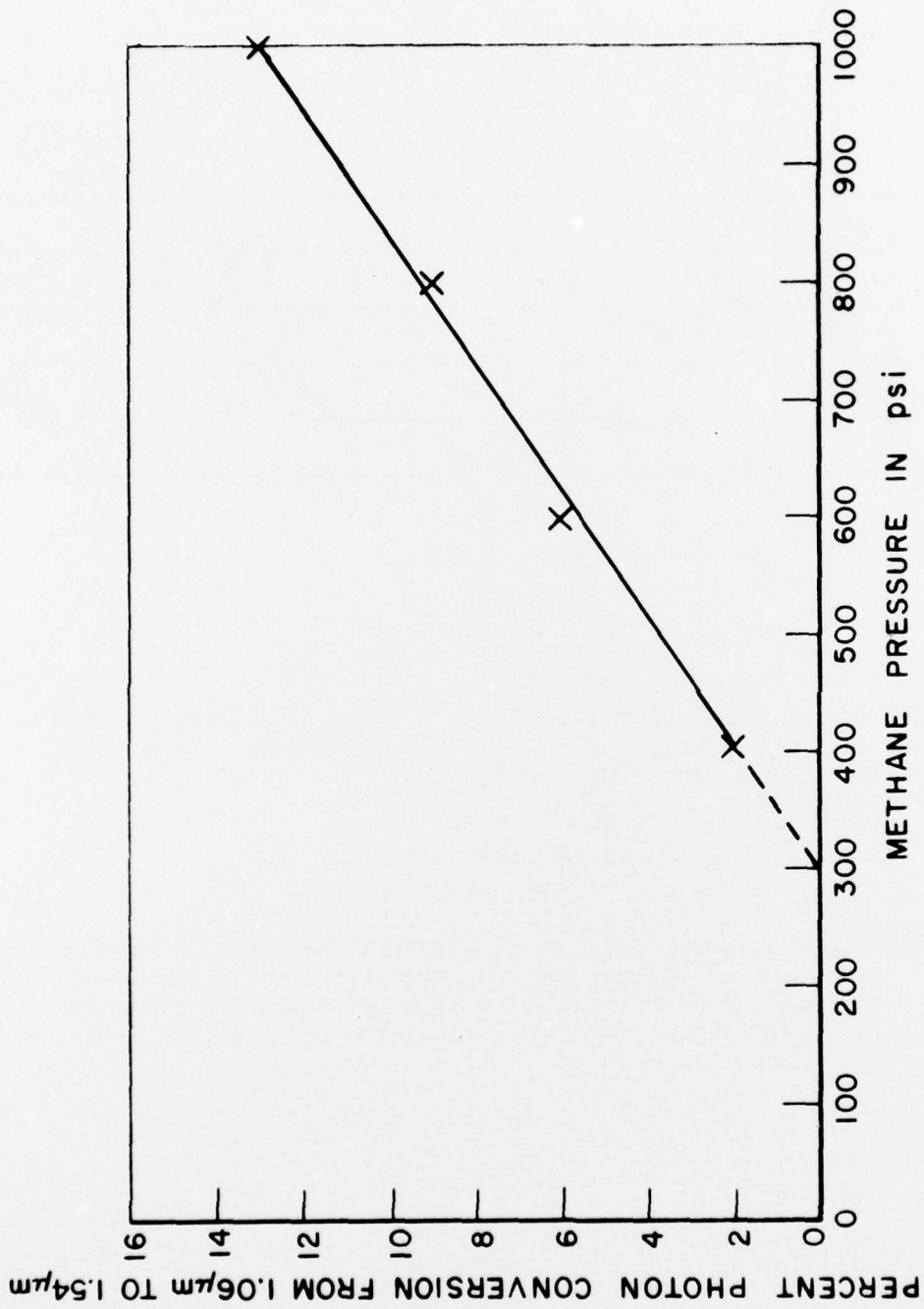
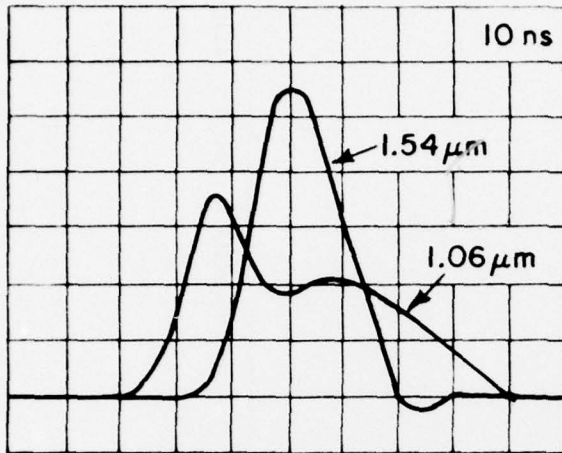
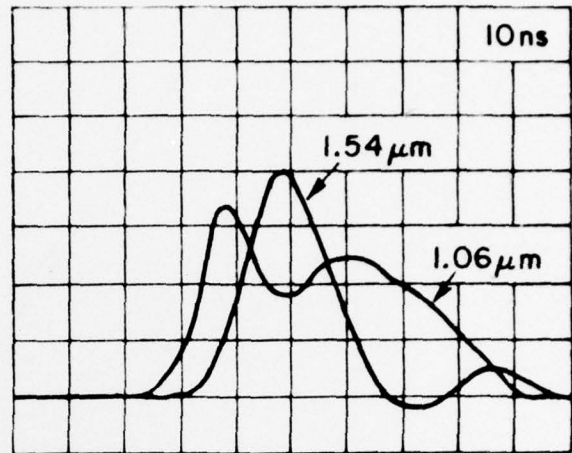

Figure 6. Photon conversion efficiency with respect to the transmitted pump energy in the presence of backscattered pump energy for the layout of Figure 1 as a function of pressure.



(a)

lens focal length = 57cm
 (30cm lens in Figure 1
 replaced by 57cm lens with
 needed adjustment in
 distances)



(b)

lens focal length = 30cm
 (as shown in Figure 1)

Figure 7. Pulse waveforms showing temporal behavior of the depleted laser pulse and the generated focusing lenses. Time increases from left to right and number in the upper right hand corner gives the time per division along the abscissa.

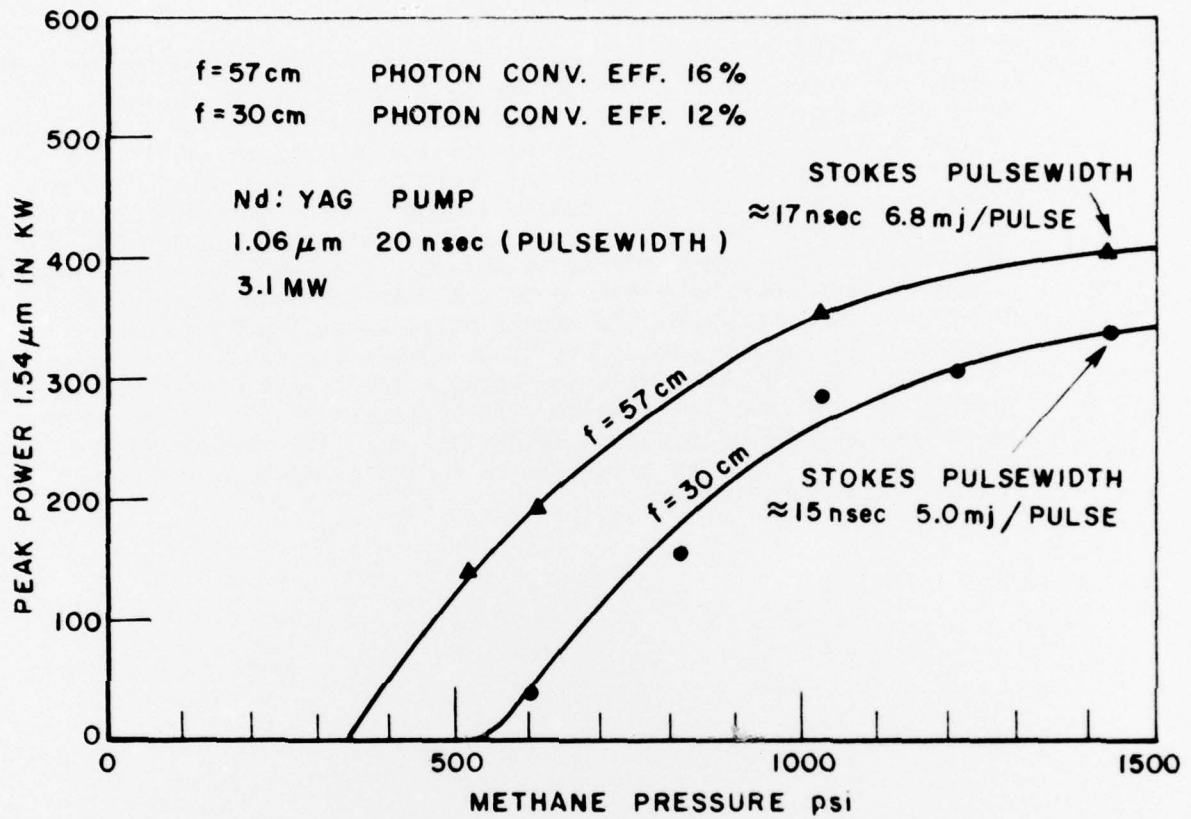

Figure 8. Peak Stokes power as a function of pressure for two different focusing lenses.

efficiencies calculated from the oscillograms. The largest Stokes energies measured from the methane Raman cell were 6.8 millijoules per pulse for 64 millijoules pump input energy.

The critical mirror alignment for peaking the conversion of pump energy to first Stokes radiation can be accomplished by using a Ge detector and oscilloscope. By continuously monitoring the first Stokes output while adjusting the laser mirror the peak power of the $1.54\mu\text{m}$ radiation is caused to increase and decrease in amplitude. If the scope is triggered off the Q-switch trigger, the time delay between the leading edges of the pump pulse and the Stokes pulse can be observed. As the output mirror is adjusted the laser and Raman pulses change in time position relative to the Q-switch trigger; also the relative time position of the Stokes pulse under the pump pulse changes. The maximum Stokes amplitude always corresponded to the adjustment for minimum time delay between the Q-switch trigger and the leading edge of the Stokes pulse. This adjustment also affected the laser pump pulse but to a much lesser degree. The maximum Stokes output occurred when the rise time on the laser pulse was shortest for our laser system.

III. SRS IN CAPILLARY GEOMETRY

Efficient energy conversion by Raman scattering in the one micron wavelength region is hampered by the wavelength dependence of Raman cross sections and the limitation on interaction length due to the diffraction of the Stokes beam from the pump focal region. One technique for alleviating this problem is through the use of an optical waveguide inside the high pressure Raman cell to extend the pump interaction length [5]. Hollow dielectric waveguides with bores whose diameters are many wavelengths will support field distributions within the waveguide which are independent of wavelength and exhibit low propagation losses [6]. This situation, in principle, leads to an indefinite interaction length. Furthermore, if SRS generates single mode radiation at the Stokes wavelength, the Stokes output would be diffraction limited. Analytical results indicate that a TEM₀₀ Gaussian spherical beam can be coupled to the low loss EH₁₁ mode of the hollow dielectric waveguide with a small insertion loss [7,8].

For the practical application of this technique to the problem of generating 1.54 μ m radiation by SRS in methane with a Nd:YAG source in a compact geometry, two points require mention. In short hollow dielectric waveguides, it is not clear that a stable mode structure for the fields can be established in the absence of feedback particularly if the pump beam is multimode as was the case with our laser pump. If indeed the pump can be inserted into the waveguide in a single low-loss mode, the energy conversion by SRS occurs over a distributed interaction length and this feature will influence the mode structure of the Stokes beam. In resolving this point, consideration should also be given to mode losses and mode coupling due to intensity dependent propagation effects in the interaction volume of the hollow dielectric waveguide.

The experimental results for pyrex capillaries of approximately one millimeter bore were essentially the same as those obtained in Part II using focusing and recollimating lenses. With a measured laser beam divergence of about 1.5 milliradians half-angle, this level of Stokes power is anticipated for calculated interaction lengths, i.e., distance around focal point where pump power density exceeds that for SRS threshold.

Peak laser powers of 3.6 MW were available as input to the Raman set-up; however, with the optics, beamsplitters, windows, and the methane cell (at atmospheric pressure) in the beam, only 3.1 MW peak powers were available in the transmitted beam. With a 57 cm positive lens and a 15 cm pyrex capillary in the methane cell, 84% of the 3.1 MW was coupled through the hollow dielectric waveguide corresponding to a transmitted peak power of 2.6 MW. All conversion efficiencies are based on the peak power and energy in this transmitted beam. Figures 9 and 10 show pulse waveforms and present the Stokes peak power as a function of pressure, respectively.

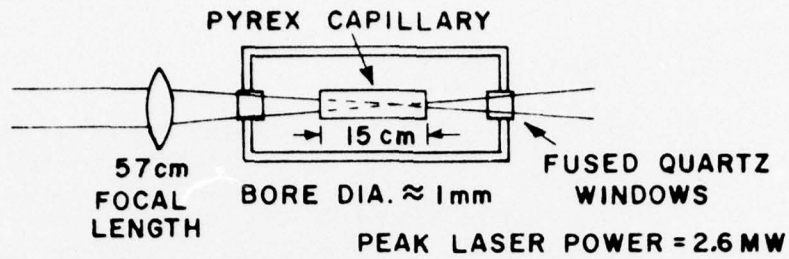

EACH PHOTO SHOWS:

(a) TRANSMITTED LASER POWER WITHOUT SRS

(b) TRANSMITTED LASER WITH SRS

(c) STOKES PULSE AT $1.54\mu\text{m}$

Ge PHOTO DIODE DETECTOR

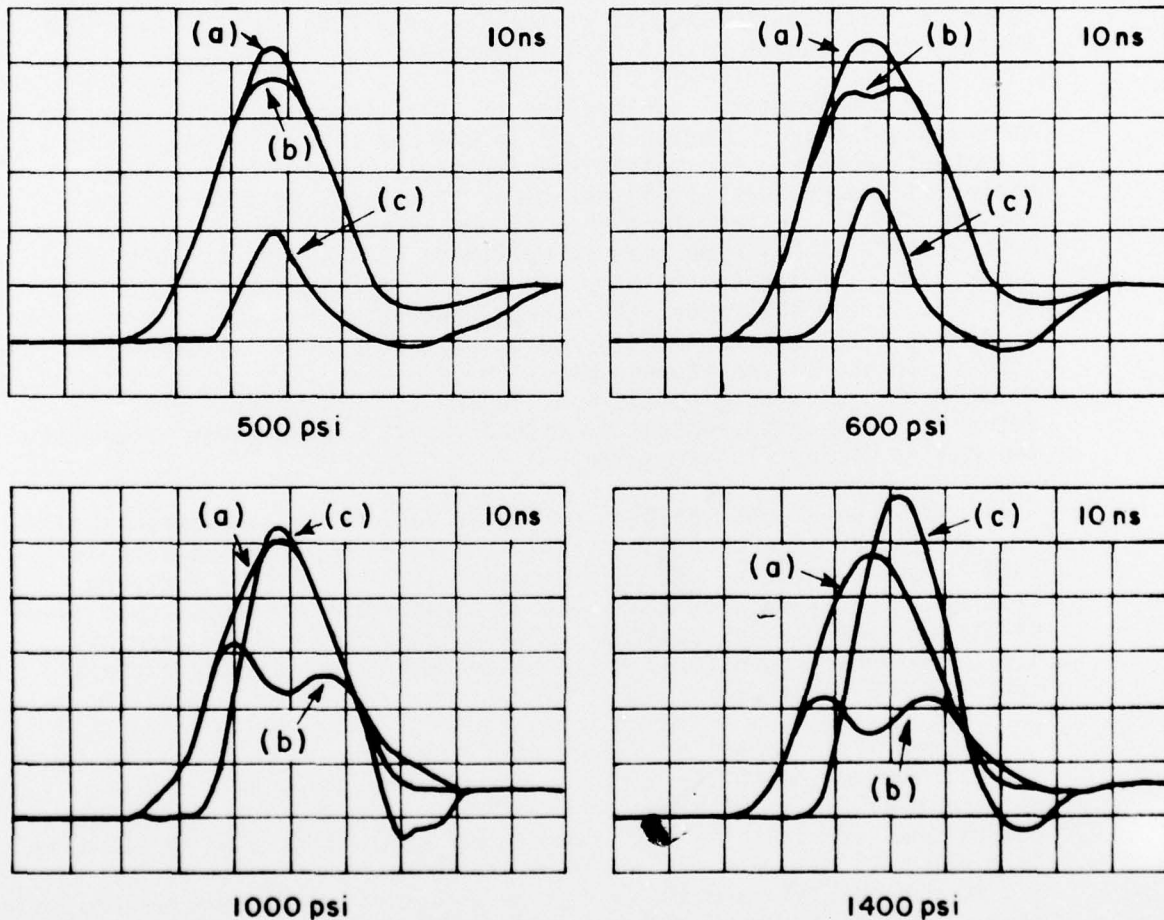

Figure 9. Waveforms for laser pump pulse, depleted laser pulse, and Stokes output for a 15 cm pyrex capillary of 1mm bore as pressure is varied. Time increases left to right and each division along the abscissa represents 10ns.

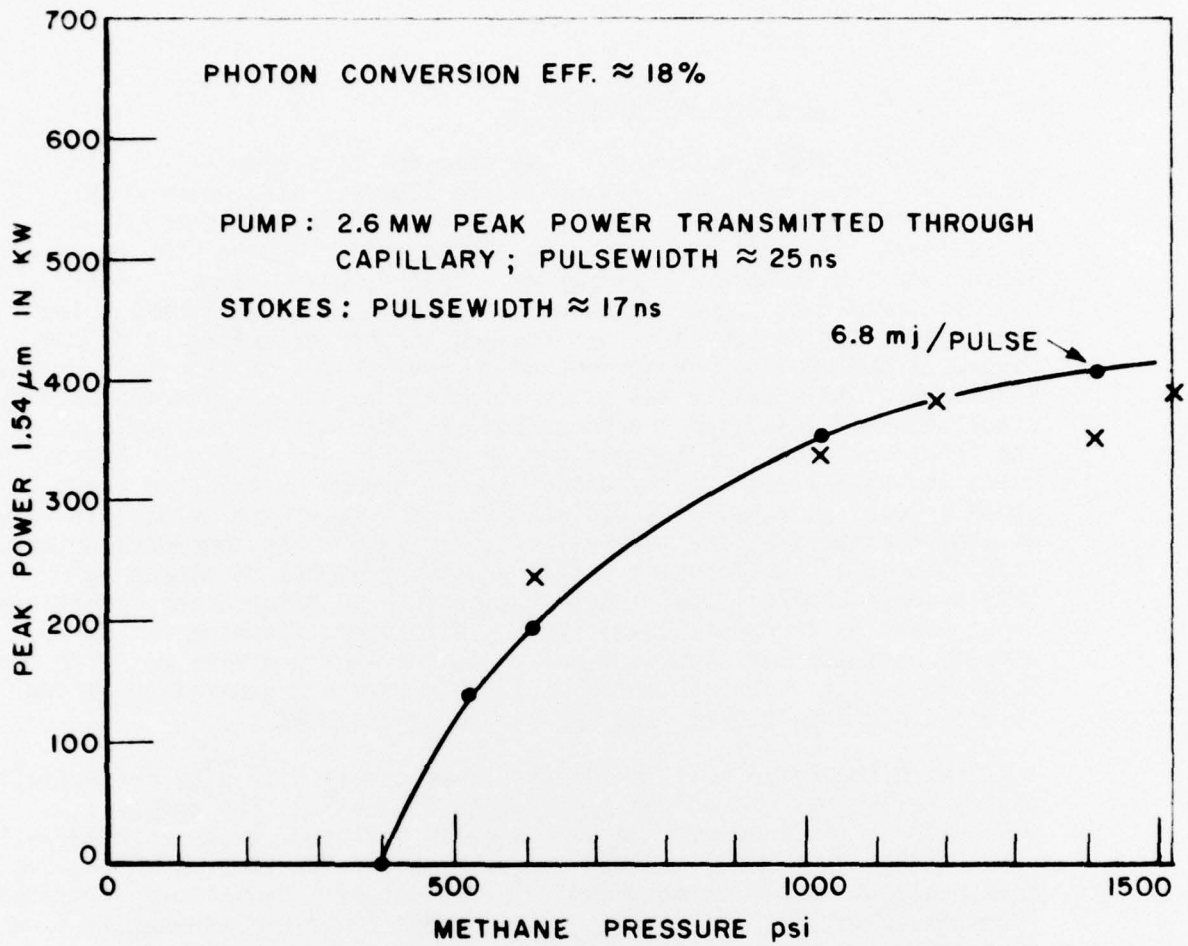

Figure 10. Peak Stokes power vs. pressure from 15cm (denoted by bold dots) and 20cm (denoted by x) pyrex capillaries of 1mm bore diameter. A 57cm focal length lens was used to couple the pump energy into the capillary.

IV. SRS WITH METHANE CELL INTERNAL TO LASER CAVITY

A. Ohio State University Work

A small high pressure cell was used for this experiment. The 10 cm long Raman cell was pressurized to 1000 psi with methane and placed inside the laser cavity. A pair of 6 cm focal length plano-convex lenses were placed around the Raman cell. Neither the focusing lenses nor the Raman cell windows were coated, which gives a single pass power loss at $1.06\mu\text{m}$ of about 30% (8 uncoated interfaces). The front reflector of the laser was changed to 98% reflecting at $1.06\mu\text{m}$. Figure 11 depicts the arrangement of components inside the laser cavity. Alignment of this cavity was extremely critical and was accomplished by simultaneously adjusting the focusing lens spacing and the angle of the front reflector. Alignment can be accomplished with a Ge photodiode and oscilloscope or by observing the second anti-Stokes beam which appears as a red ring radiated from the front reflector. It should be noted that the generation of anti-Stokes is dependent on the focal length of the focusing optics and the presence of Stokes generation. Shorter focal length optics tend to enhance the observable Raman power in the anti-Stokes lines. With short focusing optics we usually generate anti-Stokes lines up to the fourth order; but with long focusing optics, such as the 57 cm lens in Part II, generation of the second order anti-Stokes line was a rare occurrence.

With the Raman cell inside the laser cavity with high reflectivity $1.06\mu\text{m}$ reflectors around the cavity (see Figure 11), the energy conversion efficiency must be discussed in different terms than Parts II and III; however, the flashlamp energy remained the same as in the two previously discussed experiments. The amount of $1.06\mu\text{m}$ energy radiated from this cavity is insignificant. The peak power measurement at $1.54\mu\text{m}$ from the laser output mirror was measured to be 300 KW with an 8 nsec total pulsewidth between half power points. An equal amount of $1.54\mu\text{m}$ power was also measured radiating from the rear laser cavity reflector. The total energy radiated from the laser cavity was 4.8 mj per pulse. The amplitude stability of the Stokes beam was very good for this optical configuration. The exact pulse shape, peak power, and pulsewidth for the $1.54\mu\text{m}$ radiation are dependent on the coupling between the laser cavity and the SRS energy conversion configuration which serves as the output coupling.

B. Ft. Monmouth Work on Raman Designator

During the course of this study, a research program investigating SRS by methane internal to the cavity of a Nd^{+3} :YAG laser was conducted independently by Mr. William C. Beattie at Ft. Monmouth. In his work a resonant cavity at $1.54\mu\text{m}$ with mirrors of 100% and 85% reflectivities at the Stokes wavelength was placed inside the laser cavity.

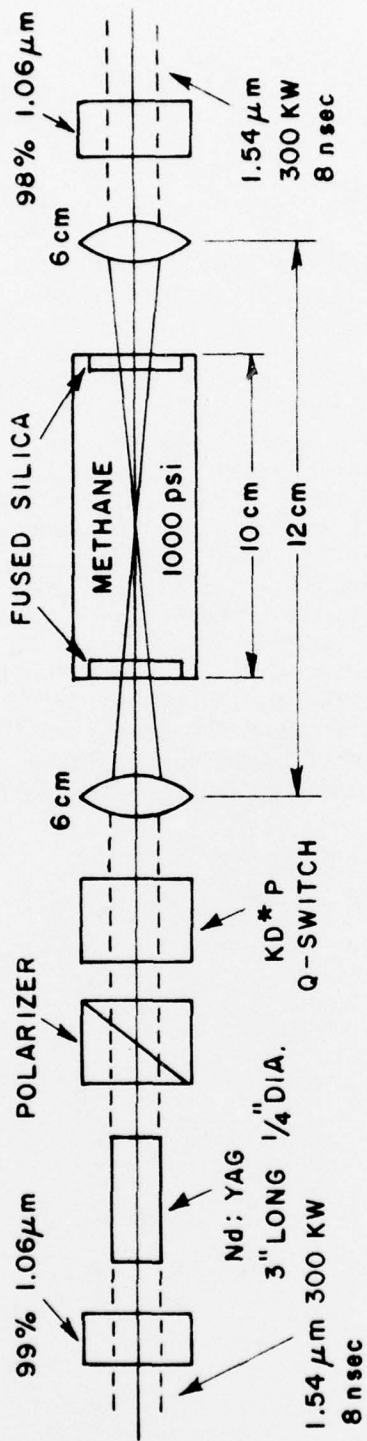

Figure 11. Optical layout for SRS with Raman cell inside laser cavity.

When carefully aligned with a methane pressure of 1500 psi, Stokes output was measured to be nominally 1 MW peak power with a pulsewidth of approximately 4 nanoseconds. Energy measurements showed the energy at $1.54\mu\text{m}$ to be 5 millijoules [9].

At Mr. Beattie's invitation, we visited his laboratory with our detectors; applying the same techniques used to make our measurements, we were able to confirm his results and cross-reference experimental conclusions. The amplitude stability of the Stokes power pulse from this Raman designator was truly remarkable.

The $1.54\mu\text{m}$ pulse occurred on the leading edge of the laser pulse and actually reached its peak value and cut-off before the laser power pulse would temporarily achieve its maximum value in the absence of SRS. This result suggests that the Raman cavity is overcoupled to the laser cavity and very rapidly converts the available $1.06\mu\text{m}$ energy to Stokes energy which could reduce the pump power density below threshold thus causing the Stokes beam to cut-off at a time that appears premature. Another possible explanation or contributing factor to this temporal behavior of the Stokes pulse stems from transient mode structure in the laser cavity fields due to the substantial energy conversion; during this transient, mode effects may cause backscatter much as observed in external Raman cells (see Section I) which substantially increases the losses inside the laser cavity. Experimental results that would substantiate or discredit either of these conjectures or alternatives were not obtained.

V. SUMMARY AND CONCLUSIONS

Two distinct regimes of energy conversion have been reproducibly observed in our study of stimulated Raman scattering. In one case significant backscatter of the laser pump from the interaction volume occurs; a study of the temporal characteristics of this phenomena suggests that the backscatter is due to Brillouin scattering. By very slight adjustment of the laser output mirror, the backscattered pump energy could be eliminated and the Stokes peak power increased substantially. The pump pulse envelope was not altered in a noticeable manner during this adjustment, but changes in the internal mode structure of the output beam had to occur to bring about such a dramatic change in the Stokes power level. We were not able to quantitatively describe changes in the laser beam quality with the diagnostic equipment available for this work. It should be noted that this behavior was observed in both the focused beam and capillary geometries external to the laser cavity. When backscatter was observed the stability of the Stokes peak power showed substantial fluctuations; however, with adjustment to the maximum peak power at the Stokes wavelength, the amplitude stability of the Raman shifted beam closely approximated that of the laser pump. The photon conversion efficiency from $1.06\mu\text{m}$ to $1.54\mu\text{m}$ for both regimes was about 15% when referred to the transmitted pump power.

With the Raman cell inside the laser cavity, the amplitude of the Stokes beam (300 KW peak power at $1.54\mu\text{m}$ from each end of the laser cavity) was very stable with an estimated variance of about 5%. The Stokes energy per pulse was 4.8 millijoules in an 8 nanosecond pulse from methane at 1000 psi.

These results, in conjunction with the work by Mr. Beattie at Ft. Monmouth, clearly establish the feasibility of building a $1.54\mu\text{m}$ rangefinder or designator with a small, compact methane Raman cell internal to the cavity of a Nd^{3+} :YAG laser. Two aspects of this problem need further study:

- (a) The Raman cell inside the laser cavity may be modeled as a power dependent saturable loss with a power density threshold. This loss is used as the means for coupling power out of the laser cavity via the $1.54\mu\text{m}$ Stokes field generated by stimulated Raman scattering in methane. The problem of maximizing the Stokes energy for this optical configuration needs to be studied analytically and confirmed experimentally. Eventual success in this approach can be inferred from the current work.

- (b) If a clever technique can be found for shortening the laser pulse while maintaining the pump energy per pulse, a substantial increase in Stokes generation would be realized in both internal and external Raman cells. Examination of the pulse shapes in Figure 9 shows that most of the pump energy is contained in the base of the pulse corresponding to power levels below threshold for SRS. Once Raman threshold is achieved the energy conversion from pump to Stokes is very efficient.

REFERENCES

- [1] J. G. Meadors, M. A. Poirier, D. F. Cornwell and W. T. Kavage, "Difference Frequency Mixing of Nd:YAG With Its Raman Shifted Beam to Generate Intense Infrared Radiation," Report 2757-3, October 1971, The Ohio State University ElectroScience Laboratory, Department of Electrical Engineering; prepared under Contract F33615-69-C-1074 for Air Force Avionics Laboratory. (AD 888633L)
- [2] J. G. Meadors and M. A. Poirier, "Generation of Infrared Radiation by Raman Scattering and Difference Frequency Mixing with a Nd:YAG Pump," IEEE J. of Quantum Electronics, QE-8, 1972, p. 427.
- [3] J. G. Meadors, "Parametric Devices," Final Report 2757-4, January 1973, The Ohio State University ElectroScience Laboratory, Department of Electrical Engineering; prepared under Contract F33615-69-C-1074 for Air Force Avionics Laboratory. (AFAL-TR-73-6)
- [4] B. G. Huth, G. I. Farmer, H. Lo and V. W. T. Townsend, "1.54 Micron Laser Transmitter," Final Report on Contract No. DAAB07-71-C-0095 for U. S. Army Electronics Command, Fort Monmouth, New Jersey 07703.
- [5] P. Rabinowitz, A. Kalder, R. Brickman, and W. Schmidt, "Waveguide Raman Laser," Applied Optics 15, 1976, p. 2005.
- [6] E. A. J. Marcatili and R. H. Schmelzter, "Hollow Metallic and Dielectric Wave-guides for Long Distance Optical Transmission and Lasers," Bell Syst. Tech. J. 43, 1964, p. 1783.
- [7] P. W. Smith, "A Waveguide Gas Laser," Appl. Phys. Lett. 19, 1971, p. 132.
- [8] R. L. Abrams, "Coupling Losses in Hollow Waveguide Laser Resonators," IEEE J. Quant. Electron. QE-8, 1972, p. 838.
- [9] W. C. Beattie, "Progress Report on Raman Designator," 1 December 1975 (Unpublished).