

AD-A042 514

VERVE RESEARCH CORP ROCKVILLE MD
STUDY REQUIREMENTS FOR AN INTEGRATED AIR/GROUND COMMUNICATIONS --ETC(U)
MAY 77 J HANSEN, A WEBSTER, B REYNOLDS

F/G 17/2.1

DOT-FA75 WAI-570

UNCLASSIFIED

VS-29

FAA-RD-76-154

NL

OF 4
AD
A042514



SIFIED

1 OF 4

AD

A042514



AD A 042514

12

Report No. FAA-RD-76-154

STUDY REQUIREMENTS FOR AN INTEGRATED
AIR/GROUND COMMUNICATIONS FACILITY



DDC
AUG 4 1977
C

May 1977

Final Report

Document is available to the U.S. public through
the National Technical Information Service,
Springfield, Virginia 22161.

AD No. _____
DDC FILE COPY

Prepared for

U.S. DEPARTMENT OF TRANSPORTATION
FEDERAL AVIATION ADMINISTRATION
Systems Research & Development Service
Washington, D.C. 20590

NOTICE

This document is disseminated under the sponsorship of the Department of Transportation in the interest of information exchange. The United States Government assumes no liability for its contents or use thereof.

<p>1. Report No. 18 FAA-RD-76-154 ✓</p>	<p>2. Government Accession No.</p>	<p>3. Recipient's Catalog No.</p>	
<p>4. Title and Subtitle 6 Study Requirements for an Integrated Air/ Ground Communications Facility.</p>		<p>5. Report Date 11 16 May 1977</p>	<p>6. Performing Organization Code</p>
<p>7. Author(s) 12 John J. Hansen, A. Webster, B. Reynolds</p>		<p>8. Performing Organization Report No. 14 VS-29 ✓</p>	<p>10. Work Unit No. (TRAIS)</p>
<p>9. Performing Organization Name and Address Verve Research Corporation UniBank Building 17th Floor 51 Monroe Street Rockville, Maryland 20850 12334 P.</p>		<p>11. Contract or Grant No. 15 DOT-FA75 WAI-570</p>	<p>13. Type of Report and Period Covered 9 Research and Development June 1975-August 1976, rept.</p>
<p>12. Sponsoring Agency Name and Address Federal Aviation Administration Systems Research & Development Service 2100 Second Street, S.W. Washington, D.C. 20591</p>		<p>14. Sponsoring Agency Code</p>	
<p>15. Supplementary Notes</p>			
<p>16. Abstract The structure, performance, maintenance, and versatility of FAA Air/Ground Communication facilities are evaluated, using a system approach to analyze requirements and costs.</p> <p>Guidelines have been developed by this study for effectively defining Air/Ground facilities to support present and future operations of the National Airspace System. As a primary example, an integrated OAKLAND ARTCC model is designed which consolidates its associated communication facilities, and is responsive to its operational and maintenance requirements.</p>			
<p>17. Key Words Communications Air/Ground Radio Facilities VHF Radio System Design</p>		<p>18. Distribution Statement Document is available to the U.S. public through the National Technical Information Service, Springfield, Virginia 22161.</p>	
<p>19. Security Classif. (of this report) UNCLASSIFIED</p>	<p>20. Security Classif. (of this page) UNCLASSIFIED</p>	<p>21. No. of Pages 333</p>	<p>22. Price</p>

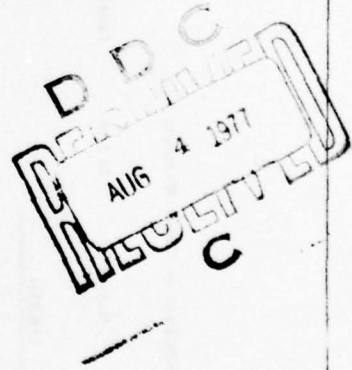

510409711

409711

mt

METRIC CONVERSION FACTORS

Approximate Conversions to Metric Measures

Approximate Conversions from Metric Measures

Symbol	When You Know	Multiply by	To Find	Symbol	When You Know	Multiply by	To Find	Symbol
LENGTH								
in	inches	*2.5	centimeters	cm	millimeters	0.04	inches	in
ft	feet	30	centimeters	cm	centimeters	0.4	inches	in
yd	yards	0.9	meters	m	meters	3.3	feet	ft
mi	miles	1.6	kilometers	km	kilometers	0.6	miles	mi
AREA								
in ²	square inches	6.5	square centimeters	cm ²	square centimeters	0.16	square inches	in ²
ft ²	square feet	0.09	square meters	m ²	square meters	1.2	square yards	yd ²
yd ²	square yards	0.8	square meters	m ²	square kilometers	0.4	square miles	mi ²
mi ²	square miles	2.6	square kilometers	km ²	hectares (10,000 m ²)	2.5	acres	ac
MASS (weight)								
oz	ounces	28	grams	g	grams	0.035	ounces	oz
lb	pounds	0.45	kilograms	kg	kilograms	2.2	pounds	lb
	short tons (2000 lb)	0.9	tonnes	t	tonnes (1000 kg)	1.1	short tons	st
VOLUME								
tsp	teaspoons	5	milliliters	ml	milliliters	0.03	fluid ounces	fl oz
Tbsp	tablespoons	15	milliliters	ml	liters	2.1	pints	pt
fl oz	fluid ounces	30	milliliters	ml	liters	1.06	quarts	qt
c	cups	0.24	liters	l	liters	0.26	gallons	gal
pt	pints	0.47	liters	l	cubic meters	35	cubic feet	ft ³
qt	quarts	0.95	liters	l	cubic meters	1.3	cubic yards	yd ³
gal	gallons	3.8	liters	l				
ft ³	cubic feet	0.03	cubic meters	m ³				
yd ³	cubic yards	0.76	cubic meters	m ³				
TEMPERATURE (exact)								
°F	Fahrenheit temperature	5/9 (after subtracting 32)	Celsius temperature	°C	°C		Fahrenheit temperature	°F

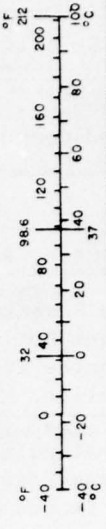
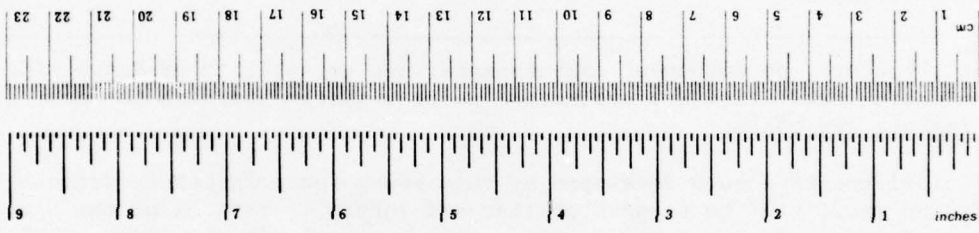

*1 in. = 2.54 cm exactly. For other exact conversions and more detailed tables, see NBS Misc. Publ. 286, Units of Weights and Measures, Price \$2.25, SD Catalog No. C13.10.286.

EXECUTIVE SUMMARY

ACCESSION for	White Section	<input type="checkbox"/>
AFIS	B.H. Section	<input type="checkbox"/>
DDC		
JANUARY 1960		
J.S. SECTION		
BY		
DISTRIBUTION/AVAILABILITY NOTES		
DATE		
		A

The results of the review of current air/ground radio system status, the impact of Upgraded Third Generation (UTG) programs and the various tradeoff analyses indicate that, relative to VHF/UHF radio communications, the FAA is at a cross-roads. The system, as it is presently configured, is not cost effective; is not structured for optimum operational responsiveness to current requirements; and does not meet the requirements posed by several of the UTG Programs. The choice appears to be one of continuing the present course and mode of operation with the addition of near-term engineering improvement, or of initiating an orderly program of modernization that will not only achieve compatibility with the general National Airspace System (NAS) automation approach, but also introduce a configuration designed to meet both short-term and long-term objectives.

The first choice is in keeping with traditional improvement programs for communications within FAA, wherein specific subsystems are scheduled for near-term improvement without consideration for total system optimization. The second choice applies an approach that considers the entire spectrum of air/ground radio service and implements a program based upon priority of requirements, costs, and the long-term outlook.

This study, although it is a research and development program, concludes that none of the improvements considered and recommended in this report require exploratory development. The necessary technology is proven and only requires system engineering and specification.

All of the suggested improvements to air/ground service are internal to FAA and do not require user (aviation community) participation--with two exceptions:

- (1) If the data transmission option is selected, it is evident that the air carriers, military, and, potentially, general aviation will have to install data link encoder/decoder units to utilize the system.
- (2) The impact of the Flight Service System Program is such that a large number of additional leased line remoting circuits will be required. A cost-effective approach would be to introduce a facility and line sharing concept that requires the introduction of Selective Calling (SELCAL) units in user aircraft. This approach must be carefully evaluated in terms of the impact on the general aviation community.

Parts One and Two of this report provide background information; Parts Three and Four set forth the approach, analysis, and evaluation of the study; and Part Five presents a concept of air/ground radio service that incorporates the results of the analyses. The following paragraphs briefly summarize the principal analyses done in this study.

IMPACT OF RELATED PROGRAMS

The majority of UTG programs are concerned with automation in order to achieve the goals of safety and efficiency of operations. Those programs that have an impact upon air/ground communications require real time, automated digital communications with aircraft. The current manual voice radio system operated by the air traffic controller cannot cope with the response time requirements. However, introducing a digitally controlled air/ground network for radio control will come very close to achieving a full air/ground data transmission capability. By extending the basic digitally controlled ground network to include an air/ground digital data transmission capability, a system results that is DABS compatible. A DABS compatible system will handle DABS-generated air/ground message traffic, and will also interface directly with automated IPC, **conflict alert**, and metering and spacing air/ground communications traffic. The alternative to VHF/UHF air/ground radio, as currently employed, is voice radio for flight services and a manual backup (voice) to the automated National Airspace System.

RADIO COVERAGE

The radio coverage analysis, which was applied only to Oakland (ZOA), shows that a number of radio facilities may be eliminated. There are three reasons for the substantial reduction:

- (1) En route flight service communications may be provided within the current radio coverage of the ZOA en route facilities (RCAG); thus the air/ground FSS facilities may no longer be required. This applies to the primary FSSs and does not eliminate any NAVAID facilities.
- (2) There is no evident advantage to the employment of BUEC facilities as a backup for air/ground radio coverage, unless the site provides good overlap coverage. In most cases, the RCAGs provide adequate primary and secondary coverage.
- (3) Certain of the RCAGs do not appear necessary in order to provide adequate ZOA radio coverage.

AVAILABILITY/RELIABILITY/MAINTAINABILITY

Examination of the five subsystems that comprise an air/ground radio channel (control site, Telco lines, radio facility, radio propagation channel, and aircraft radio) shows that the radio channel is the weak link, with an estimated 90% reliability and inadequate signal margin. Proper design of the remaining four subsystems can achieve a subsystem availability of 0.99998.

The present redundancy of Telco lines and radio equipments is excessive for the required availability. Ratios of 2 or 3 spares for up to 10 telephone lines and up to 20 radio equipments are adequate for 100% availability of service. The spare radios should be tunable transceivers.

The introduction of logical switches for maintenance and radio control must be carefully designed so as not to degrade reliability performance.

AIR/GROUND RADIO NETWORK SWITCHING AND CONTROL

It was found that the most cost-effective approach is to implement a digitally controlled switched network for air/ground radio service that uses strategically

placed line concentrators at outlying (from the ARTCC) locations adjacent to selected Maintenance Sector Offices. The use of line concentrators allows a substantial reduction in leased circuit mileage; results in the most cost-effective operations for FSS-Hub personnel; and is consistent with real time radio access and control. The use of a digitally controlled network eliminates all analog tones, line filters, and mechanical stepping switches and relays. Additionally, the configuration provides real time radio access and control.

For ZOA, four concentrators appear warranted by the area configuration.

The switched network also will handle data transmission for air/ground radio service, if desired.

AUTOMATED FACILITY MAINTENANCE

Facility and Telco maintenance were analyzed, and an approach was selected that stresses simplicity of design and focuses on the detection of unscheduled failures and real time service restoral.

One objective of the FAA, with respect to facility maintenance, is to achieve automated site certification. However, certain procedures, such as receiver calibration (e. g. , setting AVC levels), receiver selectivity check, and frequency measurement require a substantial number of operations and instrumented measurements that are more efficiently accomplished by a technician. A compromise approach is to automate failure detection, service restoral, and record keeping, thereby reducing the number of visits to a facility by a factor of approximately 12 to 1.

Facility maintenance is divided among radio systems; power; switching, monitoring, and control; and physical plant. Radio receiver performance is checked with a measure-of-noise-figure. Radio transmitter performance is checked with measures of forward power, reverse power, and percentage modulation. The remaining measurements are standard relay closures when monitor levels exceed set tolerances that are pre-programmed. A microprocessor configuration will easily handle the required processing load.

The Telco lines are checked with the Coder-Decoder/Modulator-Demodulator (CODEC/MODEM) that bridges each telephone circuit at the control site and the radio facility.

In all cases, the air traffic controller has a number of options to assure continuous service.

AUTOMATED ATC OPERATIONS

By extending data-link communications beyond the radio facility, i.e., on the radio propagation path, a full data transmission capability is obtained for air/ground radio service. As a by-product of the implementation, a means for checking channel performance by measuring the frequency of word errors is realized. Automated air/ground radio service that interfaces with NAS/ARTS, IPC, DABS, and Conflict Alert also becomes available. This approach results in a 10 to 1 reduction in controller communication time, which leads to a significant increase in controller productivity. The system will support real time air/ground data transfer consistent with separation assurance requirements.

RADIO FREQUENCY ENVIRONMENT

Current site geometry and interference are analyzed to determine the effect of clustered antennas in a confined space, particularly with regard to intermodulation interference. The number of antennas is reduced by eliminating the swastika antenna and employing transmit/receive (TR) switches and multicoupler/combiners.

Criteria are developed for selecting site configurations for both en route (RCAG and FSS) and terminal (RTR) facilities.

CONCEPT FOR AIR/GROUND RADIO SERVICE

A concept is described that integrates the principal findings of the study. It is based upon linking all control sites (i.e., en route ATC, terminal ATC, and Flight Services) to a collection of remote radio air/ground facilities through a digital, switched network. The controller/specialist gains access to radio facilities, with the required service volume coverage, through an interactive radio position panel. Remote radio facility and connecting leased line utilization is maximized by co-location of facilities, wherever feasible; by line concentration; and by the introduction of more efficient redundancy of radio equipments and leased circuits. By applying digital control, the response time of the system approaches real time

for both radio channel access and service restoral. The net result is that utility is improved, performance is improved and substantial cost-savings are realized.

AIR/GROUND FACILITIES FOR NAS RADIO SERVICE

General guidelines are developed for radio facility configurations, and an example is provided that applies the guidelines to the Mt. Tamalpais en route and flight service facility.

The intermodulation products that may be generated are calculated to assess the level of expected interference.

NAS RADIO SERVICE PROGRAM PLAN

The early initiation of a coordinated FAA Program for the implementation of an integrated NAS Radio Service offers the advantage of responding to near term deficiencies, as well as fielding a system that will meet all current and future communications requirements.

Since no exploratory development is contemplated, a low risk program can proceed with an immediate preparation of the appropriate specifications.

It is recommended that a model Center Area be selected (e. g. , ZOA) for initial reconfiguration and implementation. This recommendation presents three major task areas:

- (1) Control site radio access and control
- (2) Maintenance facility and line concentrator
- (3) Radio facility reconfiguration and integration

These task areas must be addressed concurrently, since the three areas are strongly interdependent.

The total program should involve coordination with various elements of the aviation community.

FOREWORD

This study and analysis is broader in scope than initially intended because of the requirement to identify and understand the various configurations with which an air/ground radio facility must interface. As will be seen, it was necessary to consider in detail all the subsystems that comprise an air/ground radio channel. This system view has proved valuable in establishing an orderly configuration that: first, defines a complete air/ground radio operation and its maintenance and, second, focuses attention on those subsystems that require substantial improvement. It has also proved more reasonable to discuss cost-effectiveness in terms of a total system view that realistically identifies the tradeoffs involved. It is recommended that the overview established in this study be retained as a program planning guide in support of future efforts.

The study was made possible by the coordinated efforts of the Contractor (Verve Research Corporation) and numerous Federal Aviation Administration (FAA) Regional and Headquarters personnel. Five Regions were visited during the course of the study and many informative discussions took place that provided insight into air/ground operations and maintenance.

I would like to make specific acknowledgement for the support and assistance, during the study effort, of:

Mr. Newel Anderson, Chief, ARD-220, for overall direction and guidance
Mr. Sherman Tynes, ARD-223, FAA Project Manager
Mr. Leonard Bosin, ARD-220
Mr. Paul Milani, T.I.D. assigned to Oakland (ZOA)
Mr. James Coyle, NAFEC-ANA--330
Mr. John Walls, NAFEC-ANA--330

Additionally, the members of the FAA's Radio Communications System Steering Committee have supported this effort with their helpful comments and technical review of the study's progress.

John Hansen
Program Director

CONTENTS

EXECUTIVE SUMMARY	iii
FOREWORD	ix
LIST OF EXHIBITS	xv

Part One BACKGROUND

1	PURPOSE OF STUDY	1-1
2	CURRENT AIR/GROUND RADIO COMMUNICATIONS OPERATIONS	
	2.1 General	2-1
	2.2 Radio Operations	2-5
	2.3 Summary of Air/Ground Radio Functions as Performed by Operating Positions	2-11
3	AIR/GROUND RADIO FACILITY CONFIGURATIONS	
	3.1 General	3-1
	3.2 En Route Radio Facilities	3-3
	3.3 Terminal Radio Facilities	3-5
	3.4 Flight Service Radio Facilities	3-6
4	AIR/GROUND RADIO PERFORMANCE	
	4.1 General Overview	4-1
	4.2 Air/Ground Communications Service Availability	4-10

Part Two NAS RADIO SYSTEM PERFORMANCE OBJECTIVES

5	AIR/GROUND SYSTEM IMPROVEMENT	
	5.1 General	5-1
	5.2 ATC System Response	5-3

	5.3 Availability/Reliability/Maintainability.	5-4
	5.4 Standardization.	5-4
	5.5 Radio Coverage.	5-5
	5.6 Radio Service Utilization.	5-10
	5.7 Radio Frequency Environment.	5-10
	5.8 Automated Maintenance.	5-11
	5.9 Automated Operations.	5-12
	5.10 Cost Considerations.	5-14
6	IMPACT OF RELATED PROGRAMS	
	6.1 General.	6-1
	6.2 Flight Service Station Program.	6-3
	6.3 Aircraft Separation Assurance Program (ASAP).	6-4
	6.4 Discrete Address Beacon System (DABS).	6-8
	6.5 Intermittent Positive Control (IPC).	6-9
7	SUMMARY OF AIR/GROUND RADIO SERVICE OBJECTIVES	
	7.1 General.	7-1
	7.2 Air/Ground Radio Service Objectives.	7-1
	Part Three STUDY AND ANALYSIS APPROACH	
8	SUMMARY OF STUDY AND ANALYSIS APPROACH	
	8.1 General Guidelines.	8-1
9	SYSTEM DESIGN RATIONALE	
	9.1 Introduction.	9-1
	9.2 Facility Placement	9-1
	9.3 Air/Ground Network Structure.	9-2
	9.4 Reliability	9-2
	9.5 Standardization	9-3
	9.6 Automation.	9-4
	9.7 Facility Utilization.	9-4

Part Four ANALYSIS AND EVALUATION

10 RADIO COVERAGE

10.1 Introduction 10-1

10.2 Methodology 10-2

10.3 Results 10-3

11 AVAILABILITY/RELIABILITY/MAINTAINABILITY

11.1 Introduction 11-1

11.2 Air/Ground Service Reliability 11-3

11.3 Air/Ground Service Reliability with Switching 11-5

11.4 Air/Ground Radio System Availability and Reliability
Apportionment 11-7

11.5 Service Availability Relationships 11-10

11.6 Standby Redundancy and Reliability 11-16

11.7 Service Availability (Control Site - Telco - Radio Facility) 11-23

11.8 Service Availability (Aircraft Radios) 11-25

11.9 Service Availability (Radio Channel) 11-25

11.10 Summary 11-32

12 AIR/GROUND RADIO NETWORK SWITCHING AND CONTROL

12.1 Introduction 12-1

12.2 Network Structure 12-4

12.3 Radio Access and Control 12-9

12.4 ATC Radio Position Logic 12-15

12.5 FSS-Hub Radio Position Logic 12-20

12.6 Estimated Service Times 12-21

12.7 Call Processing 12-27

12.8 Summary 12-28

13 AUTOMATED FACILITY MAINTENANCE

13.1 Introduction 13-1

13.2 Maintenance Network Structure 13-2

13.3 Air/Ground System Maintenance Operations 13-6

13.4 Site Maintenance Configuration 13-10

	13.5 Maintenance Subcenter	13-19
	13.6 Summary	13-20
14	SEMI-AUTOMATED ATC OPERATIONS	
	14.1 Introduction	14-1
	14.2 Air Traffic Control Communications Language	14-2
	14.3 Efficiency of Automated Air/Ground Communications	14-7
	14.4 Controller Interface Functions	14-10
	14.5 Voice/Data Interface	14-13
	14.6 Data Communications Reliability	14-16
	14.7 Summary	14-20
15	RADIO FREQUENCY ENVIRONMENT	
	15.1 Introduction	15-1
	15.2 General Siting Considerations	15-2
	15.3 Co-location RFI Due to Intermodulation	15-18
	15.4 Receiver Desensitization Problems	15-33
	15.5 Recommended Equipment Configurations for Specific Site/Geometry	15-36
	15.6 Loaded Antennas	15-39
	15.7 Summary	15-39
Part Five NAS RADIO SERVICE		
16	AIR/GROUND RADIO SERVICE CONCEPT	
	16.1 General Overview	16-1
	16.2 Control Site	16-5
	16.3 Maintenance Subcenter	16-7
	16.4 Radio Facilities	16-9
	16.5 Design Methodology	16-10
	16.6 Summary	16-12
17	AIR/GROUND FACILITIES FOR NAS RADIO SERVICE	
	17.1 General	17-1
	17.2 Radio Site Configuration	17-3
APPENDIX		
	Glossary of Acronyms	A-1

LIST OF EXHIBITS

Part One BACKGROUND

	<u>Page</u>
2-1	Flight Operations & NAS Functions 2-6
3-1	FSS and Associated Sites. 3-7
3-2	FSS Radio Frequencies and Usage 3-8
4-1	Current List of Reportable Facilities and Services 4-3
4-2	Example Page From the ZOA STARS Report 4-6
4-3	Example Page From ZLC STARS Report 4-7
4-4	Example 1 of Unsatisfactory Condition Report 4-8
4-5	Example 2 of Unsatisfactory Condition Report 4-9
4-6	Summary of Performance Data for ECOM, TCOM and RCAGS: All Regions 4-11
4-7	Example of Facility and Service Outage Report Form 4-12
4-8	Illustrative LASS Lines Performance Data, By ARTCC 4-13
4-9	Illustrative Non-LASS Lines Performance Data, By ARTCC 4-14
4-10	Illustrative Telco Circuit Performance Data 4-16
4-11	Illustrative Six-Month MTBO Performance Data for ZOA 4-17
4-12	FAA-Prepared Comparison of Western Region RCAG Reliability to National Average Reliability 4-18

Part Two NAS RADIO SYSTEM PERFORMANCE OBJECTIVES

5-1	John F. Kennedy RT Rack Layout - Transmitter Equipment 5-6
5-2	John F. Kennedy RR Rack Layout - Receiver Equipment 5-8
5-3	Alphanumerics Distribution 5-13
6-1	Principle Features of UTG ATC System 6-2
7-1	NAS Radio Service Objectives 7-2

Part Three STUDY AND ANALYSIS APPROACH

(No Exhibits)

Part Four ANALYSIS AND EVALUATION

		<u>Page</u>
10-1	Sector Service Volume Dimensions	10-9
10-2	ZOA RCAG: Sector Frequency Assignments	10-10
10-3	ZOA ATCTs: Sector Frequency Assignments	10-11
10-4	ZOA FSSs: Frequency Assignments	10-15
10-5	Coverage Contour Mt. Tamapais RCAG - 20,000 ft.	10-19
10-6	Coverage Contour Ferndale RCAG - 20,000 ft.	10-20
10-7	Coverage Contour Red Bluff BUEC - 20,000 ft.	10-21
10-8	Coverage Contour Red Bluff RCAG - 20,000 ft.	10-22
10-9	Coverage Contour Fallon RCAG - 20,000 ft.	10-23
10-10	Coverage Contour Angels Camp RCAG - 20,000 ft.	10-24
10-11	Coverage Contour Mt. View RCAG - 20,000 ft.	10-25
10-12	Coverage Contour Ferndale RCAG - 6000 ft. Sacramento RCAG - 7000 ft.	10-26
10-13	Coverage Contour Red Bluff BUEC - 8000 ft.	10-27
10-14	Coverage Contour Reno RCAG - 12,000 ft. Fallon RCAG - 10,000 ft. Mina RCAG - 10,000 ft.	10-28
10-15	Coverage Contour Angels Camp RCAG - 4000 ft; 14,000 ft.	10-29
10-16	Coverage Contour Fresno RCAG - 2000 ft.	10-30

	<u>Page</u>
10-17	Coverage Contour. 10-31 Paso Robles RCAG - 3000 ft. 5000 ft; 8000 ft.
10-18	Coverage Contour. 10-32 Mt. View RCAG - 5000 ft.
10-19	Coverage Contour. 10-33 Mt. Tamalpais RCAG - 3000 ft.
10-20	Coverage Contour. 10-34 Priest RCAG - 5000 ft; 8000 ft.
10-21	Coverage Contour. 10-35 Red Bluff RCAG 8000 ft; 12000 ft.
10-22	ZOA-HAT Sector Assignments. 10-36
10-23	ZOA-LAT Sector Assignments. 10-37
10-24	Oakland (ZOA) Flight Service Sectors. 10-39
10-25	Typical Distribution of Loading for Radio Contacts at a Hub Complex. 10-40
10-26	ZOA-FSS Sector Assignments. 10-41
10-27	ZOA En Route ATC/FSS Sector Assignments. 10-42
10-28	Angels Camp Remote Communications Air/Ground Sites Cost Data. 10-45
10-29	Remote Communications Air/Ground Site Cost Data Summary. 10-48
10-30	Fresno Flight Service Station Cost Data. 10-49
11-1	Primary Fault-Tree for A/G Radio (No Redundancy). 11-2
11-2	Reliability for Redundant Systems. 11-4
11-3	Reliability with Monitoring and Switching. 11-6
11-4	Current and Required Availabilities. 11-9
11-5	Availability-Maintainability-Reliability Relationships. 11-11
11-6	Mean Time to Restore Service. 11-14
11-7	Facility Travel Exercise. 11-15
11-8	System Reliability. 11-18
11-9	Telco Circuit Redundancy. 11-20
11-10	Individual Circuit Performance. 11-21
11-11	All Region Radio Equipment Cost Trade-off. 11-22

	<u>Page</u>
11-12	Solid State Receiver Noise Figure. 11-27
11-13	System Noise at Receiver Input. 11-28
11-14	Air/Ground Power Budget 11-29
11-15	Optimum Antenna Heights. 11-31
12-1	A/G Radio Ground Leased Circuit Costs. 12-2
12-2	ZOA RCAG Leased Circuit Costs. 12-2
12-3	FSS Projected Costs to FSS Center. 12-3
12-4	ZOA Projected Annual Leased Circuit Costs 12-3
12-5	Network Concept for Air/Ground. 12-6
12-6	Oakland (ZOA) Switched Network. 12-7
12-7	Airway Facilities Sector Offices 12-8
12-8	Oakland Line Concentrator 12-10
12-9	Fresno Line Concentrator 12-11
12-10	Reno Line Concentrator. 12-12
12-11	Red Line Bluff Concentrator. 12-13
12-12	Radio Access and Control. 12-14
12-13	Controller Position Configuration 12-18
12-14	Controller Dual Position Configuration. 12-19
12-15	The Notation Used in This Section. 12-22
12-16	Formulas for Single-Server Queues. 12-23
12-17	Queueing Results. 12-26
13-1	Western Region Airway Facilities Sectors and Boundaries. 13-3
13-2	Maintenance Network Concept 13-4
13-3	Radio Facility Performance Monitoring. 13-11
13-4	Receiving System Noise Figure Measurement. 13-13
13-5	A Two-Transistor Majority Voter. 13-14
13-6	Switching Circuit Failure Probabilities and Reliabilities. 13-15
13-7	Site Maintenance Configuration. 13-17
13-8	Line/Radio Channel Failure Detection and Isolation. 13-18
13-9	Maintenance Facility 13-21
14-1	ATC Language Categories. 14-3

	<u>Page</u>
14-2	Channel Utilization - Pilot and Controller 14-8
14-3	Distribution of Message Type for Single-Message Transmissions . . . 14-9
14-4	Air/Ground Voice/Data Configuration 14-15
14-5	DPSK Signalling in Gaussian Noise 14-17
14-6	Code Construction 14-19
15-1	Typical Antenna Tower 15-4
15-2	Circularly Polarized VHF Antenna 15-5
15-3	UHF Horizontal Plane Antenna Radiation Pattern 15-7
15-4	VHF Horizontal Plane Antenna Radiation Pattern 15-8
15-5	VHF Transceiver Configuration 15-10
15-6	VHF Receiver Configuration 15-11
15-7	Two and Four Port Transmitter Combiners 15-12
15-8	Transmitter Combiner Configurations 15-14
15-9	Existing RCAG Antenna Tower Configuration 15-16
15-10	Modified RCAG Site Configuration 15-17
15-11	Possible IM Generating Geometry 11-20
15-12	Mixer Conversion Losses 15-23
15-13	Total Mixer Conversion Loss as a Function of Product Order 15-24
15-14	IM Product Level as a Function of Site Geometry 15-24
15-15	Second and Third Order IM Products at VHF 15-26
15-16	Second and Third Order IM Products at UHF 15-27
15-17	Separate vs. Combined Radio Sites 15-29
15-18	Comparison of IM Products at VHF 15-30
15-19	Estimated Front End Filter Response 15-34
15-20	Integrated Transmitter & Receiver Site Configurations 15-37
15-21	Antenna Configurations for Separate RT and RR Sites 15-38

Part Five NAS RADIO SERVICE

	<u>Page</u>
16-1	Overview of the Air/Ground Radio Service Concept 16-3
16-2	Control Site Configuration - Radio Access and Control 16-6
16-3	Maintenance Facility with Line Concentrator 16-8
17-1	Mt. Tamalpais Site Layout 17-7
17-2	Mt. Tamalpais Antenna Layout 17-8
17-3	Mt. Tamalpais Current Frequency Assignment 17-9
17-4	Mt. Tamalpais RCAG Building 17-10
17-5	Mt. Tamalpais Remote Communications Air/Ground Site Cost Data 17-11
17-6	Modified Mt. Tamalpais Frequency Assignments 17-13
17-7	Mt. Tamalpais Rack Layout 17-14
17-8	Mt. Tamalpais Frequency - Antenna Configuration 17-15
17-9	Mt. Tamalpais Antenna Switching Configuration 17-16
17-10	Typical Selectivity Characteristics 17-17
17-11	UHF Multiplexer Equipment Specification 17-18
17-12	Mt. Tamalpais IM Products 17-19
17-13	IM Generation Program (3rd Order Products) 17-20

Part One
BACKGROUND

1. Purpose of Study
2. Current Air/Ground Radio Communications Operations
3. Current Air/Ground Radio Communications Configurations
4. Current Air/Ground Radio Communications Performance

1

PURPOSE OF STUDY

The purpose of this study is to define a radio facility configuration that will support air/ground communications services for Air Traffic Control and Flight Service operations within the National Airspace System.

The purpose as stated introduces the concept of universal application of radio facilities. In terms of system cost-effectiveness, it should be feasible to design a modular radio facility configuration that may be applied in response to any requirements for air/ground communications. Such an approach carries a substantial potential for cost savings due to maximum utilization of facilities, minimization of leased telephone circuits used for remoting, and standardization of facilities, equipments, procedures, and training.

In performing the study, it has been necessary to consider a radio facility in the context of its operation--which has led to consideration of the air/ground radio communication system. Although the focus of the study is directed to the radio facility, the discussion, analysis, and many of the results are expressed in terms of the air/ground system.

Thus, in achieving the purpose of the study, a number of analyses were performed that support a cost-effective configuration for the entire air/ground system. This approach has proven valuable, since the assessment of alternative designs can be carried out with consideration of system cost-effectiveness.

Another element, inherent in the statement of purpose, is a definition of time period of intended radio facility implementation and initial operation. The

time frame of application, post-1980, was selected to allow sufficient time for facility development, test and evaluation, and procurement. However, this study concludes that no exploratory development is required for the system improvements recommended. The practical interpretation of such a result is that near-term improvements may be scheduled and programmed by specifying state-of-the-art hardware. The near-term and long-term objectives are integrated, so that the air/ground system implementation program can be truly an evolutionary one.

Finally, this report will show that current operation of air/ground radio communications must be re-examined, and a decision made concerning future operations. Air/ground radio communications appear to be placeable either in the category of a flight services support function, or in the category of a voice/data compatible system completely responsive to all requirements for communications with aircraft. The decision between alternatives will have a considerable impact on the radio facility configuration discussed in this report.

2

CURRENT AIR/GROUND RADIO COMMUNICATIONS OPERATIONS

2.1 GENERAL

Radio communications provide a vital service in support of air traffic control and general flight service operations. In fact, the two functions fundamental to the air traffic control process are surveillance and communications. Together, these provide FAA controllers with capabilities for following aircraft flight and for air/ground communications.

Within the volume of controlled airspace, the FAA is responsible for supporting flight operations with air/ground communications, navigation aids, and air traffic services.

The organization of National Airspace Operations divides the conterminous United States into 20 ARTCC areas, each of which handles en route and terminal air activity within its jurisdiction. A number of non-ATC functions grouped under the heading of Flight Services augments the basic ATC en route and terminal operations. Following this organizational structure, air/ground radio communications support en route ATC operations; terminal ATC operations; and Flight Service operations.

En route ATC operations in the conterminous United States are performed by air traffic controllers located at the 20 ARTCCs, who communicate with operating aircraft via line-of-sight radio facilities termed RCAGs. These are located so as to provide adequate communication coverage over the volume of controlled airspace--primarily the VOR Federal Airways and the Jet Route System.

Terminal ATC operations are performed by air traffic controllers located at Terminal Radar Approach Control Facilities (TRACONS) and Air Traffic Control Towers (ATCTs), who communicate with operating aircraft via line-of-sight radio facilities termed Remote Transmitter-Receiver Facilities (RTRs). Located on or near the airport terminal, RTRs provide adequate coverage on the airport surface as well as in Transition Areas and Control Zones.

Flight Services are provided by specialists located at Flight Service Stations (FSSs), who communicate with operating aircraft via line-of-sight radio facilities located at the FSSs and other remoted outlets utilized to provide adequate coverage over the VOR Airway System (designated from 1200 feet above the surface to 18,000 feet MSL.)

For en route and terminal ATC operations, the airspace is partitioned into service volumes assigned to individual air traffic controller positions. The service volumes are shaped to allow a single radar controller to handle the peak expected load of an activity occurring within the designated volume of airspace. The corresponding radio communications coverage must coincide with the controller's designated airspace.

Currently, there are 694 en route air traffic control sectors (service volumes). Each of these requires an air/ground radio channel. The controller communicates with aircraft within his volume or area of responsibility via a single radio channel operating in the VHF frequency band. Since military aircraft are equipped to operate in the UHF frequency band, each VHF radio channel is augmented with a corresponding UHF radio channel. A controller operates the two channels to cover his sector, communicating with both civil and military aircraft.

The Air Traffic Control sector is a basic unit in air/ground communications operations, since each sector requires a radio channel assignment. The sectors are configured to correspond to a maximum controller volume of activity of 180 aircraft per watch for a radar sector and 120 aircraft per watch for a manual sector. The capability of 180 operations is based on a controller team concept

comprising a radar controller who handles air/ground communications, supported by an assistant controller and a radar hand-off controller. The sectors or service volumes are shaped to efficiently contain airway segments and operating areas within the constraint of prescribed air activity. The size of a sector is a direct function of the density of air traffic, so that large sectors are associated with low air activity and may require multiple radio locations in order to provide line-of-sight radio coverage over the entire area.

Flight Services are provided primarily for en route general aviation aircraft operating under VFR conditions. The current distribution of Flight Service Stations (approximately 320) results in service areas of 100 to 200 miles radius from a given FSS. In order to provide additional radio coverage, the FSSs also utilize remoted communications outlets located at 54 RCOs, 533 LRCOs, and 9 SFOs. These facilities, numbering a total of 916, share common radio frequencies at most locations and are therefore unprotected relative to potential co-channel interference.

The air-ground communications described above are utilized by air traffic controllers and inflight specialists to provide three major elements:

- (1) Air Traffic Control. The ATC function encompasses the real time issuance of instructions to aircraft in order to maintain required separation between aircraft operating in controlled airspace. The communications provide guidance to the aircraft relative to its position (x, y, z) and its speed. Because the controller receives track information on aircraft operating in an assigned sector, traffic flow can be regulated to achieve safe and efficient operations. But all communications transactions must be accomplished in near real time to correlate with the updated surveillance data received with each scan of the radar (6-10 seconds). Since such communications are critical to separation assurance, the quality and reliability must be extremely high.
- (2) Traffic Advisory Information. While ATC communications instruct each aircraft in controlled airspace, traffic advisory information advises the aircraft regarding the position of proximate aircraft representing a

potential conflict within the airspace. Pilots obtain information concerning air activity in their vicinity by monitoring the communications channel that is operated in a sector broadcast mode, and by direct traffic advisories pointing out the position of nearby aircraft. The limitations on the accuracy of surveillance information, coupled with the lack of altitude information about VFR aircraft operating without a radar or beacon or without mode C, make it essential that controllers alert aircraft to proximate traffic. As in the case of ATC communications, the required performance is for continuous real time service over the designated airspace.

(3) Flight Service Information. Flight service information includes all non-ATC and non-traffic advisory information that assists and supports flight operations. Categories of flight service information are:

- En route communication service
- Weather information--EFAS (En Route Flight Advisory Service); TWEB
- NOTAMS--NAS status information
- Flight planning
- Emergency assistance
- Lake, island, swamp, and mountain reporting service
- Airport advisory information

While flight services are available to all aviation classes, they are primarily directed to the general aviation community. Since the general aviation population tends to occupy the lower altitudes, adequate radio coverage for flight services poses a difficult problem. The supporting air/ground communications do not fall in the same class of criticality as ATC air/ground communications because of the non-control content of the message traffic. However, the requirement for relay of ATC instructions and the requirement to provide inflight emergency assistance cause the expected level of performance to approach that of ATC communications.

2.2 RADIO OPERATIONS

2.2.1 Introduction

Air/Ground Radio Communications support all phases of aircraft flight operations from pre-taxi to final gate run-up. Exhibit 2-1 shows the various phases of flight operations and the corresponding NAS functions. The NAS functions have become synonymous with operator positions, so that, for example, the clearance delivery function is handled in most instances by a clearance delivery position. The flight services function is primarily handled by an in-flight specialist position; however, the broad category of flight services includes a number of services that are also provided by ATC controllers, as required. In general, IFR operations utilize the ATC services, while VFR operations utilize flight services.

Air/ground radio operations are divided primarily into Terminal Flight Activity, En Route Flight Activity, and Flight Services Activity. Each NAS function, within the primary divisions of air/ground radio operations, is described below.

2.2.2 Terminal Flight Activity

Clearance Delivery. The Clearance Delivery (C.D.) position is employed to issue flight clearance instructions to pilots prior to handover to the ground controller position. The normal procedure is for the pilot to initiate radio contact on the designated C.D. channel and request clearance. The C.D. controller communicates flight plan data, as printed on the appropriate flight strip, to the pilot. The pilot reads back the clearance instructions. The C.D. controller verifies the readback. The pilot contacts the C.D. controller when ready to taxi. The C.D. controller instructs the pilot to monitor the ground control channel.

Additionally, the C.D. controller may issue gate hold instructions, relay requests for flight plan changes to the ARTCC and verify receipt of ATIS.

Exhibit 2-1

FLIGHT OPERATIONS & NAS FUNCTIONS

FLIGHT OPERATION	FUNCTION
Flight Plan Clearance	Clearance Delivery
Pushback/Taxiway Entry	Ground Control
Taxi	Ground Control
Take-off	Local Control
Departure	Departure Control
En Route	En Route Control
Approach	Approach Control
Landing	Local Control
Taxi/Gate Position	Ground Control
All Flight Operations	Flight Services

The C. D. position normally employs a common radio channel for all aircraft seeking clearance. The radio coverage must extend over the airport surface to include gate areas, aprons, and ramps.

Ground Control. Ground Control covers both outbound and inbound flight activity between local control and gate or other terminals, such as general aviation, cargo, hangar, or military. Basically, the control area covers the terminal taxiway system, with the ground controller issuing such instructions and guidance as are necessary to expeditiously move aircraft between runways and gates.

The pilot contacts Ground Control on the designated common radio channel, and provides flight identification, destination, and position. The ground controller issues taxi routing instructions. The pilot reads back the instructions. If the flight is inbound, the ground controller clears the aircraft for a gate or other position. If the flight is outbound, the ground controller instructs the pilot to monitor the local control channel.

Additionally, the ground controller may issue traffic advisory information, institute holding procedures, and clear aircraft to cross runways. (Active runways are always under control of the local controller.)

Radio coverage for Ground Control must extend over the airport's taxiway system and include all parking areas.

Local Control. Local Control is responsible for runway operations for both inbound and outbound aircraft. For inbound traffic, the zone of control normally extends from 3 to 5 miles from the end of the runway to the runway exit point, and for outbound aircraft, from the runway run-up area to an initial turn execution.

For inbound traffic, the pilot contacts Local Control on passing the outer marker or approximately 5 miles from the airport. The local controller instructs the pilot on landing runway designation. The pilot reads back the instruction. The controller issues clearance to land, and may provide runway exit instructions. Normally, for inbound flights communications are kept to a minimum during the

landing sequence. Additional instructions from the local controller may include weather, runway conditions, or missed approach procedures.

For departure traffic, Local Control contacts the pilot and issues departure instructions that bring the aircraft to a take-off position. Local Control issues take-off clearance, which may include an initial turn vector. The pilot acknowledges clearance for take-off and reports start of roll. Local Control instructs the pilot to contact Departure Control when the aircraft has completed its take-off and initial turn.

Additional local control communications may occur due to weather advisories, traffic advisories, holding instructions, or aborted take-offs.

Departure Control. The TRACON handles both Departure and Arrival Control functions. The Departure Control position is responsible for accepting aircraft from Local Control and providing departure/en route transition instructions as the aircraft climb out of the terminal area.

Departure and Arrival Control activities are considered crucial ATC functions, because: aircraft activity is most dense in terminal areas, and aircraft are changing altitude, adding another dimension to potential conflict situations. The pilot contacts Departure Control on the designated radio channel. Departure Control issues instructions vectoring the aircraft from post take-off position to entry into the airway as specified in the flight plan. The pilot reads back the instructions. Depending upon the structure and complexity of the terminal airspace, the departure controller also issues any appropriate traffic advisories, weather advisories, and NAS status information. The departure controller instructs the pilot to contact En Route Control.

Approach Control. The approach control function organizes the flow of air traffic into the terminal area and sets up efficient sequencing of aircraft to match the active runway configurations. Each aircraft is accepted from the en route controller and controlled in terms of both speed and position, in order to maintain

separation but still accomplish a maximum rate of landing operations.

The pilot contacts Approach Control on the designated channel and reports identity and altitude. The approach controller issues instructions to the pilot for approach to the outer marker. Instructions to inbound aircraft are the most complex of the entire flight since accommodation must be made for sequencing multiple arrivals in a safe and efficient pattern. Altitude, direction, and speed changes are common to most arrival instructions. (Although flow control procedures may have been utilized en route, the approach controller may still have to institute delays of aircraft arrivals by means of speed changes, holding patterns or path stretching.) The pilot reads back all approach instructions. The approach controller may issue several sets of instructions during the approach phase. In large terminal areas, the function may be subdivided into initial and final approach control, handled by two positions. It is also common practice to shape a number of both approach and departure sectors to match the approach and departure air activity patterns--i.e., East-West or North-South.

The approach controller will also issue traffic advisories, weather advisories, wake turbulence advisories, and NAS status information, as required.

Radio coverage for approach and departure operations is required to extend approximately 60 miles from the air terminal, with altitude coverage from 700 feet to 14,000 feet.

2.2.3 En Route Control

The En Route Control function occurs at the ARTCCs, where midflight operations are regulated--that is, the portion of flight between departure and arrival. Some En Route Control sector assignments cover high altitudes; others cover low altitudes. In areas of low activity an En Route Control sector assignment may cover both high and low altitudes. The En Route Control function also includes transitions between en route and approach/departure operations.

Depending upon the sector location, the en route controller may be engaged in flow control procedures, climb and descent instructions, speed changes, flight plan modifications and any other required activity designed to regulate traffic flow.

The pilot contacts the en route controller and identifies the flight and altitude. The en route controller issues instructions that direct the flight over the designated airway according to the filed flight plan. If an aircraft is entering or leaving the en route phase of flight operations, additional instructions are required to effect the transition. The pilot reads back the instructions. The en route controller then instructs the pilot to contact adjacent en route service or the approach controller. Additionally, the en route controller provides traffic advisories, weather advisories, NAS status, and flight plan modifications.

The radio coverage required for en route ATC extends over all designated airways, covering a volume of airspace from 1200 feet above the surface to FL 600.

2.2.4 Flight Services

The Flight Services function is directed primarily to that portion of the general aviation community operating under VFR conditions. Inflight specialists, located at the FSSs, provide en route (non-ATC) flight operations support. The Flight Services provided include flight plan service; weather advisories; navigational service; NAS status information; collection and dissemination of pilot reports (PIREPS); DF homing and fixing; emergency assistance; and relay of ATC instructions as required.

Pilots normally contact the inflight specialist on the designated FSS radio frequency. In order to extend radio coverage, the FSS may remote several locations on the same frequency--i. e., an FSS may operate through an LRCO, an RCO or an SFO. Such multiple facility operations on the same frequency, without adequate separation, frequently generate radio interference.

FSS radio coverage is required to extend over the controlled airspace. Because the service is directed to general aviation users, low altitude coverage to 1200 feet above the surface is particularly important.

Since the information provided by Flight Services is a valuable support to flight operations, controllers will extend most of the services to IFR flights as required.

A number of Flight Services functions are provided by radio broadcast whenever the information is of general interest to pilots. Weather information is broadcast via Transcribed Weather Broadcasts (TWEB), Scheduled Weather Broadcasting, and Unscheduled Weather Broadcasts. Automatic Terminal Information Service (ATIS) is a continuous broadcast of airport status information provided as a service for high activity terminal areas.

2.3 SUMMARY OF AIR/GROUND RADIO FUNCTIONS AS PERFORMED BY OPERATING POSITIONS

2.3.1 Terminal Flight Activity

I. Clearance Delivery Position

- A. Location: ATCT
- B. Radio Outlet: RT; RR; RTR
- C. Functions
 - 1. Issues flight plan clearance
 - 2. Relays flight plan amendments between Center and aircraft
 - 3. Provides gate hold procedures
 - 4. Ensures aircraft receipt of ATIS
 - 5. Advises pilot on radio frequency change

II. Ground Controller Position

- A. Location: ATCT
- B. Radio Outlet: RT; RR; RTR
- C. Functions
 - 1. Establishes and maintains aircraft identity
 - 2. Provides taxi clearance

3. Provides taxi route instructions
4. Provides ground traffic advisories
5. Issues take-off delay instructions
6. Provides NAS status information
7. Provides ground control when required by poor visibility
8. Resolves taxiway intersection conflicts
9. Controls ground vehicle traffic
10. Advises pilot on radio frequency change

III. Local Controller Position

A. Location: ATCT

B. Radio Outlet: RT; RR; RTR

C. Functions

1. Establishes and maintains aircraft identity
2. Provides navigational assistance
3. Provides take-off and landing clearances
4. Provides take-off and landing ATC
5. Issues turnout and turnoff instructions
6. Provides traffic advisories
7. Provides weather advisories
8. Provides NAS status
9. Issues delay and holding instructions
10. Provides ground control when required by poor visibility
11. Provides ATC for missed approaches
12. Provides ATC for take-off aborts
13. Advises pilot on radio frequency change

IV. Departure Control Position

A. Location: TRACON

B. Radio Outlet: RT; RR; RTR

C. Functions

1. Establishes and maintains aircraft identity
2. Provides navigational assistance
3. Provides departure control in direction, altitude, and speed

4. Provides traffic advisories
5. Provides weather advisories
6. Provides NAS status
7. Provides emergency assistance to aircraft when required
8. Advises pilot on radio frequency change

V. Approach Control Position

A. Location: TRACON

B. Radio Outlet: RT; RR; RTR

C. Functions

1. Establishes and maintains aircraft identity
2. Provides navigational assistance
3. Provides approach control instructions
4. Organizes in bound flow of traffic
5. Provides traffic advisories
6. Provides weather advisories
7. Provides NAS status
8. Provides emergency assistance to aircraft when required
9. Advises pilot on radio frequency change

2. 3.2 En Route Control Position

I. Location: ARTCC

II. Radio Outlet: RCAG

III. Functions

- A. Establishes and maintains aircraft identity
- B. Provides navigational assistance
- C. Provides en route control in direction, altitude and speed
- D. Organizes and regulates flow of traffic
- E. Coordinates and issues clearance for flight plan modifications
- F. Provides traffic advisories
- G. Provides weather advisories
- H. Provides NAS status

- I. Provides emergency assistance to aircraft as required
- J. Advises pilot on radio frequency change

2.3.3 Flight Service Specialist Position

- I. Location: FSS
- II. Radio Outlet: FSS; RCO; LRCO; SFO
- III. Functions
 - A. Provides VFR flight plan service
 - B. Provides airport advisory service
 - C. Provides navigation orientation
 - D. Provides DF homing and fixing service
 - E. Provides weather advisories
 - F. Provides NAS status
 - G. Collects Pilot Reports (PIREPS)
 - H. Provides emergency assistance to aircraft
 - I. Provides emergency instrument approach guidance
 - J. Provides Search and Rescue Service
 - K. Relays ATC instructions as required

3

AIR/GROUND RADIO FACILITY CONFIGURATIONS

3.1 GENERAL

The utilization of air/ground radio service involves five distinct system elements:

- (1) Control site position
- (2) Remoting circuits (line or link)
- (3) Radio facility
- (4) Radio propagation path
- (5) Aircraft radio

Since the five elements listed are connected in series from the controller/specialist to the aircraft, it is essential to consider all five in an air/ground system analysis. The reliability of air/ground service is a function of each element in the series connection. A significant constraint to reliable operations is the FAA's lack of full control over the performance of all parts of the system. Specifically, in most cases the remoting circuits are leased from the telephone company, and aircraft radio performance is normally beyond the control of FAA. Within these limitations, the FAA, in its current operations, requires continuous radio service availability for ATC operations.

Three distinct control site positions are employed for en route ATC services, for Terminal ATC services, and for Flight Services. The corresponding positions for each service are located at the ARTCC, the ATCT/TRACON and the FSS.

VHF/UHF propagation is line-of-sight, so that remoted air/ground radio facilities are required to extend coverage over the airspace. Remoting circuits for communication and radio control are required to link the radio facilities with the

appropriate control site. To cover appreciable distances, remoting circuits are leased from the telephone company.

Radio Facilities are located in accordance with the service function and radio coverage required. Three major categories of radio facilities exist in the present system, associated with en route ATC service, Terminal ATC service, and Flight Services. The en route radio facilities (RCAGs) are located to provide radio coverage over the ARTCC area of responsibility for both low and high-altitude operations. Terminal radio facilities are located on or near the air terminal in order to provide approach departure ATC as well as the on-surface functions of Local and Ground Control. An air terminal may support a TRACON, and/or an ATCT, or may be a non-towered airport. The air/ground radio services provided are consistent with the amount of air activity. For non-towered airports, air/ground radio may be provided by FSS facilities or UNICOM service (these are non-ATC services and advisory only). For ATCT airports, radio for local operations is provided by the Tower, which may also provide approach control service. The radio facilities may co-exist within the Tower, with antenna configurations on the Tower roof, or a remote transmitter (RT) facility may be placed remote to the Tower and controlled by local (hard wire) circuits. For increased air activity requiring the assignment of additional radio channels, a remote receiver (RR) facility is added, remote from the Tower and also controlled via local circuits. For radar approach air terminals with an on-site TRACON (ARTS), there exists a combination of radio facilities employing ATCT and TRACON, plus RTs and RRs. The ATCT may house some number of receivers as well as spare transmitters, with a Tower roof antenna configuration, as well as one or more RTs and RRs. The TRACON may also house a number of primary and spare radio equipments with an antenna configuration on the TRACON/ATCT roof, as well as one or more RTs and RRs. If the TRACON is providing approach control service for other air terminals in the area, it will employ additional RTs and RRs at the adjacent air terminals. Such remotized RTs and RRs will be controlled via leased circuits.

Although most air terminals separate transmitter and receiver facilities (i. e., RTs and RRs), remote transmitter-receiver (RTR) facilities that combine the transmitting and receiving functions in one or more remote facilities are also

employed (e.g., at Chicago-O'Hare).

Flight Service facilities are located at air terminals in order to handle pre-flight operations for general aviation pilots. Since en route flight services are a primary function of the FSS, it is usually required to extend radio coverage over a wide area beyond line-of-sight of the FSS. To do this, the FSS will utilize a radio facility with an antenna configuration on the roof and will also employ remoted air/ground facilities: RCOs (Remote Control Outlets), SFOs (Single Frequency Outlets), and LRCOs (Limited Remote Control Outlets). In order to accommodate general aviation activity which is flying VFR and using the VOR NAVAIDs, the FSS maintains a transmit capability on the VOR radio frequency, augmented by a receive only (RO) facility placed at the VOR site. The remote circuits employed for VOR air/ground communications service are also employed to monitor and control the VORs. Selected FSSs also operate Direction Finding receivers as aids to lost or disoriented flights.

In summary, the current air/ground system employs a wide variety of radio facilities, in order to accommodate the three services described. The basic air/ground radio operation is common to all three, and each service requires reliable operation of the five elements listed at the beginning of this chapter.

3.2 EN ROUTE RADIO FACILITIES

Nationally, there are 495 RCAGs.¹ The 495 RCAGs operate a total of 2173 radio frequencies,² or an average of 4.4 radio frequencies per facility.

The RCAG is a standard shelter configuration available in three discrete sizes (1, 2, and 3) accommodating 10, 16, or 20 racks of radio equipment. Four antenna towers, each with mounts for four antennas, provide a capability for locating 16 separate antennas. The standard separation between towers is 80 feet; antennas are separated by a minimum of eight feet. A radio channel is composed of one VHF frequency and one UHF frequency (the latter supports military operations). Without

1. "Air Navigation and Air Traffic Control Facility Performance and Availability," FAA Document, RIS-SM-6040-20, FY-75.

2. Ibid.

combining antenna functions, the maximum radio channel configuration is four channels; that is, four VHF and four UHF transmitters plus four VHF and four UHF receivers. Use of transmit-receive (TR) switches, transmitter multicoupling, or receiver combining will allow additional channels within the 16 antenna configuration limitation.

Each remoted radio channel (one VHF and one UHF) is connected between the ARTCC and RCAG by either one or two telephone circuits (normally, leased circuits, type S-1142). Split-channel operation requires 2 circuits for independent VHF and UHF operations. Selective operations or paired-channel operations require one circuit for air/ground operations.

Additionally, backup leased line capability is provided by the SS-1 (Selective Signalling) System, which makes one spare circuit available per RCAG, or by LASS (line automatic, sensing and switching) System, which backs up each primary circuit with an alternate.

As an added element for supporting reliable air/ground communications, a number of Back Up Emergency Communications (BUEC) facilities are employed as alternates to the primary RCAGs. The BUEC Facility is usually co-located with the long range radar (LRR) facility. Tunable transceivers selected and controlled from the ARTCC positions via remoting circuits (normally via the LRR remote microwave link (RML)) provide backup communications for the RCAGs.

Since each RCAG radio equipment is backed up with a spare, the controller has three options available for service: 1) the main radio at the RCAG, 2) the standby radio at the RCAG, and 3) the BUEC transceiver at the LRR. The redundancy thus provided to increase availability of service is arranged as follows:

- Control site position (ARTCC)--multiple positions
- RCAG leased circuit--primary plus one SS-1 (common to the entire RCAG) or LASS (discrete alternate for each primary)
- Radio equipment at RCAG--1 main and 1 standby for each frequency
- RCAG Power--Commercial power and back-up engine generator
- Voice Frequency Signalling For PTT (push to talk) and Main-Standby Switching--one system associated with each primary-spare radio equipment

- Air/Ground Channel--BUEC provides a completely separate air/ground channel with displaced radio coverage

3.3 TERMINAL RADIO FACILITIES

There are 425 Terminal Communications facilities employing 3,835 radio frequencies. The number of Terminal Communications facilities reflects the number of ATCTs and TRACONS and does not break out the number of remote air/ground facilities, i.e., RRs, RTs, RTRs, etc. Remote radio facilities at terminals occupy a wide range of configurations that have been implemented in stages as air activity has increased. The accumulation of facilities starts with a Tower Cab facility (radio equipments in the Tower and antennas on the roof) and moves into various combinations of RR, RT, and RTR sites. Since the Tower roof usually commands an unobstructed view of the runway configuration, it is normal practice to install ground and local control capabilities on the Tower roof. The class of RRs, RTs, and RTRs assumes many different configurations, ranging from RCAG-like shelters and antenna towers to trailer shelters with antennas mounted on an ASR pedestal (e.g., at Boston-Logan). The requirements for discrete radio frequencies in support of a major air terminal can grow quickly, with maximums approaching 20 to 30 distinct frequencies. Such requirements lead to nests of antennas in close proximity, mounted on reflecting platforms. This, together with the man-made obstructions usually located on or near airports, results in a difficult radio communication environment. The configuration of antenna platforms on the airport surface assumes a variety of spacing and forms. Antenna separation may be as little as three feet, or may approach eight to ten feet, with other combinations also occurring.

There are a variety of options available for remoting communications from the operating positions to the radio equipments. Short distances are normally spanned by FAA-owned DC keying or signalling circuits accompanied by voice pairs for communication. Longer distances employ leased services from the telephone company. The placement and use of spare radio equipments differ considerably from that used for en route communications services. Standby equipment may be located within the ATCT or the TRACON, or at any of the RRs, RTs, or RTRs. Tertiary standby transceivers are

also employed for critical local and ground control frequencies. Large TRACONS (e.g., the common IFR rooms at New York and Oakland) employ a mixed combination of all described radio facilities, with FAA-owned remoting communications and telephone leased lines. Channel patching and switching may be extensive at these larger facilities (e.g., the New York Common IFR can assign radio facilities at La Guardia for use as approach control channels for Kennedy).

Site location on air terminals is made difficult by restrictions on Tower antenna platforms, e.g., Chicago O'Hare; by constraints exercised by airport management with regard to desirable field locations; and by various obstructions on or around the airport.

3.4 FLIGHT SERVICE RADIO FACILITIES

Flight Service air/ground radio service is handled by the Inflight Specialists for providing non-ATC functions primarily to VFR operations. The number of radio facilities and other FSS-associated sites is shown in Exhibit 3-1.³ The number of radio sites is 898, including FSSs, RCOs, LRCOs, and SFOs. Exhibit 3-2 lists the presently available FSS radio frequencies.⁴ The number of frequencies is limited, causing a majority of FSS-associated radio facilities to employ the same frequencies for in-flight air/ground service. The emergency frequencies 121.5 and 243.0 (UHF) are common to all FSS facilities. The frequency 122.1 is normally the RO-LRCO frequency located at the VOR NAVAID; 122.0 is assigned as the single EFAS weather advisory frequency for VFR en route operations; and 123.6 is reserved for Airport Advisory Service (AAS). Subtracting these frequencies plus those assigned for UNICOM leaves a small number for general flight services.

A typical FSS will operate 6 or 7 radio frequencies (e.g., Paso Robles, California: 121.5, 122.1R, 122.2, 122.4, 123.6, 243, and 255.4). Additionally, several LRCOs at outlying VORs will be supplied with 122.1R and have transmit capability on the VOR frequency (e.g., Paso Robles controls Avenal--117.1T and 122.1R; Priest--

3. "A Brief Survey of FSS Communications Facilities," MITRE W.P. 11092, July, 1975.

4. FAA Order 6050.26, Appendix I, April 1972

Exhibit 3-1

FSS AND ASSOCIATED SITES

(January 1974)

SITE DESIGNATOR	NUMBER OF SITES
NAVAIDS (FSS)	662
VORTAC	187
VOR	3
TACAN	
Total	852
Tower VOR	64
Radio Sites	
LRCO	538
RCO (4 Freq.)	22
SFO	9
FSS (4.5 Freq.)	319
Total	898
EFAS Sites	
Remote	98
Center	44
Total	142
DF Sites	
FSS	153
TW	61
Total	214

Exhibit 3-2

FSS AND UNICOM RADIO FREQUENCIES AND USAGE

Frequency	Present Usage	Planned Usage
121.5	Emergency	Emergency
122.0	Wx-advisory	En Route Wx Advisory Service
122.05		simplex
122.1	Rx only w/VOR	simplex or Rx only w/VOR
122.15		simplex
122.2	simplex	simplex
122.25		simplex
122.3	simplex	simplex
122.35	simplex	simplex
122.4	Rx only-twr	simplex
122.45	simplex	simplex
122.5	Rx only-twr	simplex or Rec-only twr
122.55	simplex	simplex
122.6	simplex	simplex
122.65	simplex	simplex
122.7	Rx only-twr	simplex
122.75	simplex	simplex
122.8	UNICOM	UNICOM
122.85	UNICOM High Alt.	UNICOM High Alt.
122.9	Multicom A-A A-G	Multicom A-A A-G
122.95	UNICOM High Alt.	UNICOM High Alt.
123.0	UNICOM twr and FSS airports	UNICOM twr and FSS airports
123.05	UNICOM Heliports	UNICOM Heleports
123.1	S&R, Temp twr	S&R, Temp twr
123.6	Airport advisory	Airport advisory
123.65	simplex	simplex

110.0T and 122.1R; and San Luis Obispo--112.4T and 122.1R). Aircraft at altitudes to FL150 may be received at all LRCOs, and at the FSS on 122.1. The specialist will locate the aircraft position and respond through the appropriate VOR channel.

FSS shelters are a mix of configurations, with antennas mounted on the roof of the facility or at a nearby RT or RR facility on the airport. Frequently, terminal communications facilities will house FSS radio channels. The RCO (often a formerly manned FSS) is a remotely located shelter similar in configuration to the FSS. The LRCO is most usually co-located with a VOR and is comprised of RO equipment with a pole-mounted receive antenna located adjacent to the VOR Facility. The SFO is either a single-frequency capability co-located with another FAA facility or a self-contained shelter with pole-mounted antenna. Remoted air/ground outlets are controlled via FAA owned circuits or leased telephone lines. Since the FSS is responsible for monitoring NAVAIDS, the control-communications circuits are shared with the VOR monitoring and control function. The restricted number of frequencies in close proximity, the roof mounted antenna configurations (again in close proximity), and the requirement for multiple reception of the same frequency with multiple keying of transmitters on the same frequency, are factors which in combination generate a difficult radio frequency environment. Since ATC is not the primary function of FSS communications, the requirements for service availability allow a lesser degree of radio equipment and remoting circuit redundancy.

4

AIR/GROUND RADIO PERFORMANCE

4.1 GENERAL OVERVIEW

Basically, the system employed by the FAA to measure performance collects data on service and facility outages. There are two items reported: 1) the number of outages and 2) the duration of each outage. This generally involves four numbers:

- (1) Availability. The ratio of total operating time (facility hours) to maximum available facility hours, expressed as a percentage.
- (2) Reliability. The probability that a facility will experience no outages during a 24 hour period.
- (3) MTBO. The mean time between outages.
- (4) MTR. The mean time to restore service.

The significant performance parameter that is reported is service, which refers to the end product provided to the user (e.g., an Air Traffic Controller). A communications service outage, e.g., loss of an air/ground radio frequency, refers to the loss of that service to the controller for a period of one minute or more. Performance documentation is contained in the 6040 Facility and Outage Report.

An analysis of communications performance is made difficult by this methodology of reporting, since outages of discrete communications system elements are not reportable and therefore do not appear in the statistics. For example, if a controller loses the use of an air/ground channel (due, for example, to a radio receiver malfunction) and switches successfully to the standby equipment, there is no loss of service and therefore no outage report is generated.

A further difficulty which affects communications performance analysis is the limitations on reportable facilities and services. The current list is shown in Exhibit 4-1. Flight Service Communications is not listed and is not a reportable service. Nor are any FSS Communications facilities reportable. Further, the Terminal Communications facilities (i. e. , RTR, RR, RT) are not reportable.

The current status is that communications reporting is constrained to the following:

- ECOM Reporting. ECOM reports provide the en route air/ground communication service picture as seen by the ARTCC. The ECOM location identifier is that of the ARTCC. For each service outage, the number of frequencies utilized by the ARTCC and the number of frequencies affected by the outage are recorded on FAA Form 6040-3.
- RCAG Reporting. Only outages which pertain to the RCAG facility are reported. For example, an RCAG facility outage is not shown if the Telco line fails. Frequencies out of service due to lines or links are reflected in the ECOM reports.
- TCOM Reporting. TCOM reports provide the terminal air/ground communication service picture as seen by the terminal control complex (ATCT and/or TRACON, RAPCON, etc.) The TCOM location identifier is that of the terminal. For each service outage the total number of frequencies utilized by the terminal and the number of frequencies affected by the outage are entered. If the terminal facility has no associated RTR (transmitters and receivers located at the terminal), TCOM outage reports reflect the "Service Fault Location" as being at the control site (Column 7, Section C, of FAA Form 6040-3). Combined Station/Tower (CST) facilities report communication service performance as TCOM.

CURRENT LIST OF REPORTABLE FACILITIES AND SERVICES

<u>FACILITY</u>	<u>DESCRIPTION</u>
ALS	Standard Approach Light System
ARSR	Air Route Surveillance Radar
ARTS	Automated Radar Terminal System
ASR	Airport Surveillance Radar
CD	Common Digitizer (includes Weather Fixed Map Unit, WFMU)
DMEG	Distance Measuring Equipment Co-located with GS
DMER	Distance Measuring Equipment --TACR, with DME only, commissioned
DMEV	Distance Measuring Equipment, Co-located with VOR
GS	Guide Slope
IM	Inner Marker
LOC	Localizer
MM	Middle Marker
OM	Outer Marker
RBDE	Radar Bright Display Equipment
RCAG	Remote Center Air/Ground Facility
RMLR	Radar Microwave Link Repeater
RMLT	Radar Microwave Link Terminal
RVR	Runway Visual Range
SALS	Short Approach Light System
SECRA	Secondary Radar Beacon
TACR	Tactical Air Navigation, co-located with VOR
VASI	Visual Approach Slope Indicator
VOR	VHF Omni-Directional Radio Range
<u>SERVICE</u>	
CDAT	Composite Data
CFAD	Composite Flight Data Processing
CRAD	Composite Radar (Digitized)
ECOM	En Route Communications
ERAD	En Route Radar (Broad Band)
ESEC	En Route Secondary Radar Beacon (Broad Band)
FDAT	Flight Data
IDAT	Interfacility Data
RDAT	Radar Data (Digitized)
TCOM	Terminal Communications
TRAD	Terminal Radar
TSEC	Terminal Secondary Radar Beacon

- Mobile ATCT Facilities. The net TCOM service resulting from frequencies of a permanent ATCT and frequencies of a mobile ATCT used as back-up are reflected on FAA Form 6040-3 as being the frequency performance of the permanent ATCT. In such cases the number of frequencies "in place" is reported as being the number of frequencies utilized by the permanent ATCT.

TCOM, ECOM, and RCAG outages are reported whenever one or more frequencies are "out of service." A frequency is out of service when the transmit or receive function or both are inoperable, or when performance is degraded to the point of operational unacceptability. The entry for number of frequencies "in place" must agree with the Facilities Master File.

Remoting communications via Telco lines is now reported in more detail, and line outage reports are required on all line failures involving primary, secondary, LASS, non-LASS, SS-1, etc., lasting a minute or more, regardless of the impact on the frequency involved with the particular line or lines.

Another obstacle to evaluating air/ground communications performance is the lack of data describing radio propagation performance and aircraft radio system performance. Currently, there are no means for collecting performance data describing these two elements of the air/ground system.

Within the limitations described, the FAA collects data oriented toward three primary service fault locations:

- (1) Control Site. The control site, such as an ARTCC, is the controlling end of the service chain. The control site encompasses all control, decoding, display, and other equipment associated with the control end of the particular service, exclusive of link terminals such as RMLT, CMLT, LCOT. An ARTCC is considered the control site for en route radar (ERAD), en route secondary radar beacon (ESEC), en route communication (ECOM), flight data (FDAT), etc., service reporting. A terminal facility such as an ATCT and/or TRACON, RAPCON, etc., is considered the control site for terminal radar (TRAD), terminal secondary radar

beacon (TSEC), and terminal communication (TCOM) service reporting.

- (2) Line or Link. Line or link is that portion of a service chain which provides the point-to-point transmission media between the control and remote site. Included in this portion are transmission lines; link terminals, such as RMLT, CMLT, LCOT; and link repeaters, such as RMLR, CMLR, LNKR.
- (3) Remote Site. The remote site, such as an ASR, ARSR, or RCAG, is the remote end of a service chain. The remote site encompasses all transmitting, receiving, control, and ancillary equipment associated with the remote end of the particular service chain, exclusive of link terminals such as RMLT, CMLT, LCOT. In the case of FDAT service, the terminal facility (ATCT and/or TRACON, etc.) is considered the remote site for the ARTCC.

Detailed maintenance logs maintained by each Region provide in-depth descriptions of equipment failures and repairs. However, the accumulation of statistics from such logs represents a formidable task. Summary logs are developed by the Regions for their own use and provide cryptic descriptions of system/equipment failures. Exhibit 4-2 shows an example page from the ZOA STARS Report. Exhibit 4-3 shows a similar example from ZLC.

Chronic communications problems normally are called out and coordinated between AT and AF personnel. One such means of reporting is the Unsatisfactory Condition Report (UCR) originated by AT. Two examples of UCRs are shown in Exhibits 4-4 and 4-5.

In summary, an awareness of communications performance exists at the local (and regional) level, and coordination of deficiencies is a continuous effort. Specific performance statistics and characteristics are generally unavailable without an appreciable expenditure of time in a collection process.

Exhibit 4-2

EXAMPLE PAGE FROM THE ZOA STARS REPORT

OAKLAND ARTCC RCAG HISTORY FOR NOV. AND DEC. 1975										AGE 07
ENROUTE COMMUNICATIONS SYSTEMS										
INCIDENT/OTS TIME	LCC ID	FAC TYPE	LCC MOD	UNIT ID	UNIT TYPE	ENTRY DATE	RTS CC	STAT	REMARKS	TECH
1:07	011175	FAT	C19B	OS	ZCA/FAT	353.8/123.80				
1:07	011175	FAT	C19B	OS		1207 011175 80			48410 CHNL OTS NO KICKBACK	LGT
1:07	011175	FAT	C19B	OS		1517 011175 80			NFO CALLOUT REQUESTED FROM FA	T
1:07	011175	FAT	C19B	OS		1745 011175 80			NFO FSS. TONE CHANNING FS RCVR	LGT
									CA 162174 FAILED	JTO
11:30	051275	FAT	C19B	OS	ZOA/FAT	353.8/123.80			48410 NFO REPLACED ANT AT SITE	RDJ
0:15	111275	FAT	C19B	OS		0727 111275 87			NCO TMTS REPORTED BREAKING U	P
00:36	191275	FAT	C19B	OS		0038 191275 80			N00 DIALD 55-1 LINE IN FOR 2 HOURS THEN DIALED OFF. NO FURTHER TROUBLE REPORTED.	LGT
21:19	041275	FAT	C19U	OS	ZCA/FAT	353.8			48410 A00 PCCR UHF COVERAGE-SITE TECH (JMC) REPORTS CHNL CERTIFIED	JSF
21:05	201275	FAT	C19U	OS		2030 201275 80			N00 TMTS NO GOOD NH OF CF BAKERSFIELD A 20K FT. BUEC ALSO BAD MON. NO TRB ATTH. COVERAGE	LOH
21:00	041275	FAT	C19V	OS	ZOA/FAT	123.80			48410 N00 REQUESTED CERTIFICATION D DUE POOR COVERAGE SOUTH OF FAT TOWARD BFL 30 TO 50 MILES BELOW FL230	UEP
22:00	041275	FAT	C19V	OS		2304 041275 89			N00 VHF TX ANT IS CRACKED. REORIENTED FOR TEMP FIX. ANT TO BE CHANGED.	CHP
22:00	041275	FAT	C19V	OS		1945 051275 80			N00 RFLCD ANT 1847Z A.T. CK CK	CHP
12:50	121175	FATA	C21B	OS	ZOM/FATA	319.1/132.00			48410 N00 SC BREAK INTMT BCTH VHF/ UHF RXS	JSF
10:27	221175	FATA	C21B	OS		1835 221175 89			N00 AUDIO VARYING CK OK	FEF
11:00	251175	FATA	C21U	OS	ZOM/FATA	319.1			48410 N00 TMTS REPORTED POOR COVERAGE GOOD KICKBACK + RETURNED AUDIO WILL MONITOR	MJH
00:01	271175	FATA	C21U	OS		0001 271175 69			N00 POOR COVERAGE ABOVE 42K F	AT

EXAMPLE PAGE FROM ZLC STARS REPORT

SALT LAKE CITY ARTCC		RADIO		EQUIPMENT OUTAGE AND MALFUNCTION DATA			FEBRUARY 1974		PAGE 6 OF 8	
DATE	EQUIPMENT	MAJORITY	NAJORITY	TIME NOTED	INITIAL	TIME CORRECTED	INITIAL	CAUSE OF OUTAGE OR MALFUNCTION		
15	PAM CH 34, 33		Failed	0845	MP	0910	MP	Changed voice channel on link.		
16	TPS CH 16		Receivers OTS	0910	TC	1214	TC	Main receiver bad - changed to standby.		
18	FPK CH 41		Garbled - unreadable	1255	KG	1525	KG	Have to send technician to site to set audio levels and measure receiver noise output.		
18	Delle FPK CH 4, 41		Garbled - unreadable	0900	DJ	0915	DJ	Improper selecting of more than one channel by controller.		
20	RKS CH 37		Receiver weak & broken	2030	MS	2125	MS	Suspect aircraft was bad - VIP only.		
20	EMT CH 31		Maintenance requested outage	1355	RY	1411	LE	Routine maintenance		
20	EMT CH 25		Failed	1930	MP	1940	MP	Main transmitter failed - changed to standby.		
20	EMT CH 22		Out of service	0800	LE	1045	LE	Replaced tubes - tune channel equipment.		
20	FPK Delle CH 41, 4		VIP receivers have background noise	1615	WH	----	--	Monitored - apparent use beyond range limitations.		
21	CDC CH 45		Noisy - birds chirping	1030	AR	1115	AR	Received a bird chirp on frequency from unknown location.		

Exhibit 4-4

EXAMPLE 1 OF UNSATISFACTORY CONDITION REPORT

UNSATISFACTORY CONDITION REPORT		Reports Identification Symbol OA 1800 1	
1. NAME OF ORIGINATOR (last, first, middle initial) Wallace T. Bertram		DOCUMENT NUMBER UCR— 285059	
2. OFFICE ADDRESS OF ORIGINATOR 2150 W 700 N SLC, UT 84116		ROUTING SYMBOL ATCS	3. DATE CONDITION OBSERVED May 19, 1975
4. CONDITION REPORTED <input type="checkbox"/> PROCEDURE <input checked="" type="checkbox"/> EQUIPMENT <input type="checkbox"/> WORKING ENVIRONMENT <input type="checkbox"/> SERVICES <input type="checkbox"/> PUBLICATIONS <input type="checkbox"/> OTHER (Specify in item 7)			
5. (Check if applicable) <input type="checkbox"/> PROPOSED SOLUTION ATTACHED (see item 4 on reverse)		6. ORIGINAL FORWARDED TO WASHINGTON OFFICE OR SERVICE	ROUTING SYMBOL DATE AAT-1 5/22/75
7. DESCRIPTION OF UNSATISFACTORY CONDITION (Refer to item 2 of instructions for conditions to be reported.) System exhibits chronic unsatisfactory operational characteristics. Frequency coverage for Sector 31 at SLC ARTCC, primary frequency 123.8, located at Francis Peak Radar Site is the primary location for this frequency. If loss occurs due to equipment malfunction, weather, or for any other reason the secondary site is used which is located 80 miles southeast of Francis Peak which isn't even located in Sector 31 boundaries. This site at Myton, UT, will not give adequate coverage at any altitude north as far away as Malad, ID, 200 miles. The BUEC backup primary site is also at Francis Peak so if loss occurs as stated above, you also lose your BUEC primary site. BUEC secondary site is located on top of the Center building itself which is next to useless due to mountainous terrain on all aides of the valley. This sector handles approximately 1/3 of arrival and departing traffic in and out of SLC, Ogden and HAFB, UT. Needless to say what happens when you lose your primary and secondary means of communication with this amount of traffic.			
8. SIGNATURE OF ORIGINATOR 		9. DATE SUBMITTED BY ORIGINATOR 5-22-75	
10. EVALUATIONS AND REVIEW: <i>See attached on checked sheets as needed. Attach No., office, name, and date</i>			
10a. IMMEDIATE SUPERVISOR			
SIGNATURE (Print or type and sign)		ROUTING SYMBOL	DATE
10b. AREA OFFICE			
SIGNATURE (Print or type and sign)		ROUTING SYMBOL	DATE
10c. REGION OR CENTER			
SIGNATURE (Print or type and sign)		ROUTING SYMBOL	DATE
11. OFFICE TAKING FINAL ACTION <input type="checkbox"/> RESULTS OF EVALUATION (check appropriate block and describe) <input type="checkbox"/> CONDITION CORRECTED <input type="checkbox"/> ACTION NOT POSSIBLE <input type="checkbox"/> OTHER (Specify)			
11b. REMARKS			

EXHIBIT TWO OF UNSATISFACTORY CONDITION REPORT

1. NAME OF ORIGINATOR (last, first, middle initial) Garn, Harold K.		DOCUMENT NUMBER UCR— 285067	
2. OFFICE ADDRESS OF ORIGINATOR ARTCC, 2150 West 700 North, SLC, Utah		ROUTING SYMBOL	3. DATE CONDITION OBSERVED
4. CONDITION REPORTED <input type="checkbox"/> PROCEDURE <input checked="" type="checkbox"/> EQUIPMENT <input type="checkbox"/> WORKING ENVIRONMENT <input type="checkbox"/> SERVICES <input type="checkbox"/> PUBLICATIONS <input type="checkbox"/> OTHER (Specify in item 7)			
5. (Check if applicable) <input type="checkbox"/> PROPOSED SOLUTION ATTACHED (see item 4 on reverse)		6. ORIGINAL FORWARDED TO → WASHINGTON OFFICE OR SERVICE	ROUTING SYMBOL DATE
7. DESCRIPTION OF UNSATISFACTORY CONDITION (Refer to item 2 of instructions for conditions to be reported.) <p>The transmitters and receivers for the Rock Springs, Wyoming Sector (Sector 39/40) are inadequate for radio coverage in the north quadrant of this Sector. These are Channels 37/38 at Rock Springs, Wyoming, and Channels 20/21 at Medicine Bow, Wyoming.</p> <p>We are unable to communicate, on reliable basis, to aircraft in this area. In most cases we are unable to deliver clearances or receive acknowledgements when needed, to aircraft operating on the refueling track AR-11.</p> <p>When Channel 20/21, now located at Medicine Bow, Wyoming were located at Rawlings, Wyoming, we had good radio coverage in the north quadrant of this Sector.</p> <p style="text-align: right;">4 April 1973</p> <p style="text-align: right;">4 April 1973</p>			
8. SIGNATURE OF ORIGINATOR <i>Harold K. Garn</i>		9. DATE SUBMITTED BY ORIGINATOR	
10. EVALUATIONS AND REVIEWS (continue on attached sheets as needed—show UCR No., office, name, and date)			
10a. IMMEDIATE SUPERVISOR			
SIGNATURE (Print or type and sign)		ROUTING SYMBOL	DATE
10b. AREA OFFICE			
SIGNATURE (Print or type and sign)		ROUTING SYMBOL	DATE
10c. REGION OR CENTER			
SIGNATURE (Print or type and sign)		ROUTING SYMBOL	DATE
11. OFFICE TAKING FINAL ACTION			
11a. RESULTS OF EVALUATION (check appropriate block and describe)		<input checked="" type="checkbox"/> CONDITION CORRECTED	<input type="checkbox"/> ACTION NOT POSSIBLE <input type="checkbox"/> OTHER (Specify)
11b. REMARKS A Regional project has been established to install two high gain UHF antennas in the northwest quadrant of the Radar/RCAG facility plot. Engineering is in progress and installation will be in the near future, weather permitting. This should alleviate the coverage problem. We consider this UCR closed.			
SIGNATURE (Print or type and sign) <i>R. J. Van Vuren</i> R. J. VAN VUREN, Chief, Air Traffic Division		ROUTING SYMBOL ARM-500	DATE 1-9-74

4.2 AIR/GROUND COMMUNICATIONS SERVICE AVAILABILITY

Referring again to the five elements in series that comprise an air/ground communications system:

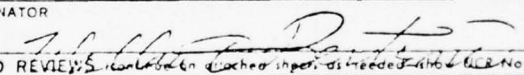
- (1) Control site,
- (2) Remoting communications (line or link),
- (3) Radio facility,
- (4) Propagation channel,
- (5) Aircraft radio,

it is evident that only items (1), (2), and (3) are reportable within the current reporting system, and that the reporting does not include discrete elements (e.g., radio equipments) or certain services and facilities, i.e., FSS Communications Services and RTRs, RTs, and RRs.

Exhibit 4-6 shows the summary data for all Regions for ECOM, TCOM, and RCAG performance. The numbers shown apply to radio frequency outages that result in loss of air/ground radio service as previously defined. The MTBO and MTR statistics refer to the service. The distinction here is that no data are available for mean time between failures (MTBF) of specific radio equipment or for mean time to repair (MTTR) of radio equipment.

In noting the Service Fault Location data, it is possible to assess the distribution of service faults among the control site, line or link, and remote site.

For example, ECOM assigns 44.26% of fault locations to line or link problems, while TCOM assigns 16.32% to the same classification. This difference reflects the utilization of shorter remoting circuits for TCOM operations, as contrasted with remoted RCAGs for ECOM operations. The form used for reporting is reproduced in Exhibit 4-7. Telco line performance for remoting communications between ARTCC and RCAGs is fully reported by both FAA and the local telephone companies. Exhibits 4-8 and 4-9 illustrate data for LASS and non-LASS lines by ARTCC for the periods indicated.

Exhibit 4-6
SUMMARY OF PERFORMANCE DATA FOR ECOM, TCOM AND
RCAGS : ALL REGIONS

	<u>ECOM</u>		<u>TCOM</u>		<u>RCAGS</u>	
	ALL REGIONS		ALL REGIONS		ALL REGIONS	
NO OF COMMISSIONED FACL		27		425		495
NO OF FREQ IN PLACE		2,213		3,833		2,173
MAX AVAIL FREQ HOURS		19,381,890		33,592,248		19,032,210
OUTAGE CAUSE CODES						
	NO	HOURS	NO	HOURS	NO	HOURS
SCHEDULED CAUSES						
00 MAINTENANCE	4352	5400	1490	1307	3355	3486
01 LINE OUTAGE	2108	3248	184	206	62	111
02 IMPROVEMENTS	839	7888	543	5798	510	3520
03 FLIGHT INSPECTION	4	8	-	-	-	-
04 ADMINISTRATIVE	217	7621	30	33	178	300
09 OTHER SCHEDULED	355	1947	146	4294	115	359
TOTAL SCHEDULED	7875	26172	2399	11637	4220	7883
UNSCHEDULED CAUSES						
80 EQUIPMENT FAILURE	2563	6113	805	2448	1162	3763
81 LINE OUTAGE	4047	8734	498	3430	119	487
82 COMM POWER FAILURE	59	207	350	488	96	87
83 STANDBY ENG GEN	552	371	963	757	291	391
84 PROP CONDITIONS	158	352	115	1123	41	66
85 WEATHER EFFECTS	345	544	33	239	58	151
86 SOFTWARE	-	-	-	-	-	-
87 SELF CORR CAUSE UNKN	1613	2014	150	317	255	508
89 OTHER UNSCHEDULED	790	2466	192	1794	248	1645
TOTAL UNSCHEDULED	9927	20799	3118	10596	2270	7299
TOTAL ALL CAUSES	17802	46971	5517	22233	6490	15182
TOTAL OPER FREQ HOURS	19,334,925		33,570,016		19,017,035	
AVG NO OUTAGES PER FREQ						
SCHEDULED CAUSES	3.56		.63		1.94	
EQUIPMENT FAILURE	1.15		.21		.53	
UNSCHEDULED CAUSES	4.49		.81		1.04	
ALL CAUSES	8.04		1.44		2.99	
AVG OUTAGE TIME PER FREQ						
SCHEDULED CAUSES	11.83		3.03		3.63	
EQUIPMENT FAILURE	2.76		.64		1.73	
UNSCHEDULED CAUSES	9.40		2.76		3.36	
ALL CAUSES	21.23		5.80		6.99	
AVAILABILITY PERCENTAGES						
OPERATIONAL	99.75		99.93		99.92	
ADJUSTED	99.80		99.95		99.94	
24-HR RELIABILITY PCT						
EQUIPMENT FAILURE OUTAGES	99.68		99.94		99.85	
TOTAL UNSCHEDULED OUTAGES	98.77		99.77		99.71	
MEAN TIME BETWEEN OUTAGES						
SCHEDULED CAUSES	2,455		13,993		4,506	
EQUIPMENT FAILURE	7,343		41,701		16,365	
UNSCHEDULED CAUSES	1,947		10,766		8,377	
ALL CAUSES	1,086		6,084		2,930	
MEAN TIME TO RESTORE						
SCHEDULED CAUSES	3.32		4.83		1.87	
EQUIPMENT FAILURE	2.38		3.04		3.24	
UNSCHEDULED CAUSES	2.10		3.40		3.22	
ALL CAUSES	2.64		4.03		2.34	
SERVICE FAULT LOCATION						
MULTIPLE LOCATION	.37		1.37			
CONTROL SITE	13.39		35.37			
LINE OR LINK	44.25		16.32			
REMOTE SITE	37.33		40.41			
UNSPECIFIED	4.63		6.51			

NOTES:
 - DENOTES ZERO OR INFINITY OR NOT APPLICABLE.
 * DENOTES HOURS TOTALING 0.01-0.4 WHERE DECIMALS ARE NOT SHOWN IN PRINTOUT.
 X DENOTES A COMPUTED VALUE GREATER THAN ZERO BUT LESS THAN 0.004.
 SERVICE FAULT LOCATION GIVES PERCENTAGE DISTRIBUTION OF THE NUMBER OF UNSCHEDULED OUTAGES BY FAULT LOCATION.

Exhibit 4-8

ILLUSTRATIVE LASS LINES PERFORMANCE DATA, BY ARTCC

JANUARY THRU DECEMBER 1975		ARTCC/RGAG TELCO LINE PERFORMANCE PERFORMANCE OF LASS LINES BY ARTCC TELCO UNSCHEDULED OUTAGES										RIS AF 6040-68	
ARTCC LOCATION	MTBO (DAYS)	MTR (HRS)	***** PRIMARY LINES OPER(1) AVAIL	NC. IN	***** NC. OUT	HOURS OUT	***** NC. OUT	AL.T. LINES HOURS OUT	***** NC. OUT	***** EFF.	OPER(3) AVAIL	SERVICE MTRBO(4) (DAYS)	
ANCHORAGE	29.1	26.9	96.2	2	8	215.1	9	575.7	9	.0	98.0	29.6	
ATLANTA	34.5	2.5	99.6	6	45	113.1	55	166.0	55	88.0	100.0	312.3	
CHICAGO	69.1	2.8	99.8	23	108	302.7	77	140.0	77	62.0	99.9	185.8	
FORT WORTH	101.9	2.6	99.6	43	112	291.6	57	102.2	57	45.0	100.0	197.7	
HGUSTON	51.7	1.1	99.7	29	204	228.2	174	213.2	174	70.0	99.9	173.3	
INDIANAPOLIS	48.4	1.5	99.7	7	52	101.2	29	63.7	29	73.0	99.9	180.2	
JACKSONVILLE	29.0	1.9	96.1	35	235	443.8	281	399.4	281	82.0	99.9	161.7	
KANSAS CITY	50.4	1.5	99.8	16	95	140.8	67	162.7	67	85.0	100.0	342.7	
MIAMI	50.0	1.4	99.7	36	262	358.9	204	455.3	204	85.0	99.9	354.9	
MINNEAPOLIS	55.0	1.8	99.9	30	183	328.9	94	87.8	94	79.0	100.0	292.5	
SEATTLE	77.2	1.2	99.8	7	33	40.5	33	25.6	33	63.0	100.0	212.8	
NATIONAL	53.7	1.9	99.4	234	1337	2564.8	1080	2391.6	1080	75.0	99.9	220.8	

(1) OPERATIONAL AVAILABILITY COMPUTED FOR TOTAL SCHED & UNSCHED HOURS OUT.

(2) PERCENT EFFECTIVE IS NUMBER OF INCIDENTS WHERE ALTERNATE LINE IS USED FOR DURATION OF PRIMARY LINE OUTAGE, DIVIDED BY NUMBER OF PRIMARY LINE OUTAGES.

(3) TOTAL ALTERNATE LINE USE TYPE IS SUBTRACTED FROM TOTAL SCHED & UNSCHED PRIMARY LINE OUTAGE TIME IN SERVICE OPERATIONAL AVAILABILITY COMPUTATIONS.

(4) SERVICE MTBO IS AVERAGE DURATION BETWEEN INCIDENTS WHERE THERE IS LOSS OF LINE SERVICE DUE TO OUTAGE OF BOTH PRIMARY AND ALTERNATE LINE.

ILLUSTRATIVE NON-LASS LINES PERFORMANCE DATA, BY ARTCC

OCTOBER THRU DECEMBER 1975		ARTCC/RCAG TELCO LINE PERFORMANCE						RIS AF 604J-68			
		PERFORMANCE OF NON-LASS LINES BY ARTCC									
		TELCO UNSCHEDULED OUTAGES									
ARTCC LOCATION	***** MTBO (DAYS)	***** MTR (HRS)	***** OPER(1) AVAIL	***** LINES IN	***** NO. OUT	***** HOURS OUT	***** NO. IN	***** SPARE NO. OUT	***** LINES HOURS OUT	***** % (2) USE	***** SERVICE OPER(3) AVAIL
ALBUQUERQUE	54.0	2.0	99.8	74	119	233.4	19	20	17.5	73.7	100.0
ANCHORAGE	37.1	12.1	98.5	34	83	1004.0	0	0	0.0	.0	98.5
ATLANTA	59.4	1.2	99.9	64	99	117.3	23	17	36.5	67.8	100.0
BOSTON-NASHUA	57.8	1.5	99.8	75	117	172.6	24	21	50.0	80.4	100.0
CHICAGO	86.3	2.2	99.9	69	72	159.5	25	13	50.2	82.1	100.0
CLEVELAND	59.6	2.1	99.6	84	128	270.9	19	22	82.5	60.8	99.8
DENVER	55.9	11.5	99.4	57	54	623.4	19	20	146.1	11.3	99.5
FORT WORTH	153.9	2.0	99.8	59	35	70.5	15	3	5.3	59.3	100.0
GREAT FALLS	41.9	1.5	99.8	21	46	70.2	6	7	18.6	6.6	99.8
HOUSTON	36.0	1.3	99.7	45	106	137.6	17	23	41.0	58.5	99.9
INDIANAPOLIS	60.1	3.4	99.7	41	59	202.3	14	10	85.3	47.2	99.8
JACKSONVILLE	33.5	1.5	99.6	59	161	249.3	25	62	150.8	55.0	99.9
KANSAS CITY	130.7	2.5	99.9	55	35	85.8	26	15	27.4	80.0	100.0
LDS ANGELES	62.4	.9	99.9	53	78	71.9	15	12	14.5	87.1	100.0
MEMPHIS	57.0	1.8	99.8	67	102	188.4	20	20	45.0	52.4	99.9
MIAMI	147.6	24.9	99.3	33	20	497.6	24	1	0.3	6.9	99.3
MINNEAPOLIS	80.0	2.9	99.8	53	57	162.6	24	21	45.0	71.6	100.0
NEW YORK	50.4	1.7	99.9	123	125	208.9	13	12	25.7	38.9	99.9
OAKLAND	77.7	2.2	99.8	43	50	110.5	11	5	7.4	85.3	100.0
SALT LAKE CY	94.3	2.4	99.8	38	37	85.6	12	7	26.2	61.5	99.9
SEATTLE	76.0	2.6	99.7	28	33	85.1	10	11	58.5	20.3	99.8
WASH., D.C.	81.0	2.1	99.9	90	102	213.4	19	13	52.0	35.5	99.9
NATIONAL	66.0	2.5	99.7	1265	1718	5023.8	360	335	985.8	36.2	99.9

(1) OPERATIONAL AVAILABILITY COMPUTED FOR TOTAL SCHED & UNSCHED HOURS OUT.
 (2) PERCENT USE IS RATIO OF SPARE LINE USE TIME TO PRIMARY LINE OUTAGE TIME.
 (3) TOTAL SPARE LINE USE TIME IS SUBTRACTED FROM TOTAL SCHED & UNSCHED PRIMARY LINE OUTAGE TIME IN SERVICE OPERATIONAL AVAILABILITY COMPUTATIONS.

Current month and rolling averages (six months) for individual circuits, as compiled by Pacific Telephone, are shown in Exhibit 4-10. The data shown are for remoting circuits to the RCAGs indicated. The MTBO numbers are specified in days.

The six month MTBO performance for ZOA is shown in Exhibit 4-11. The figure 999 indicates no outages, or 100% availability. The indicated 18-day MTBO for Priest and Fresno is equivalent to a reliability percentage of 94.5%, i. e.:

$$R_{24} = 100 \exp \left(\frac{-24}{\text{MTBO}} \right) \text{ for each 24 hour period.}$$

Exhibit 4-12 shows a relative facility performance for Western Region RCAGS, compared to the National Average Reliability.

The various data shown are indicative of the performance data available describing ECOM, TCOM, and RCAG services and facilities. The data are useful as indicators of relative service performance, but are not sufficiently detailed or complete to provide data for communications performance analysis and evaluation in support of an engineering system design. Chapter II of this report indicates that the design of air/ground system availability, reliability, and maintainability requires performance measures of MTBF and MTTR for all system elements and must be consistent with the level of engineering specification of the components of the system. For example, the GRT-21 Receiver carries a specified MTBF = 5000 hours and a MTTR = 30 minutes. Measured verification of these specifications would provide valuable inputs to an air/ground system design.

Exhibit 4-10

ILLUSTRATIVE TELCO CIRCUIT PERFORMANCE DATA

CKT NO.	CURRENT MONTH			ROLLING AVERAGE					
	NO. OUT	DUR	MTBO	NO. OUT	DUR	MTR	AVL	REL	MTBO
1GR1081	0	0.0	INF	3	1.8	.6	99.96	98.3	60.0
1GR6401	0	0.0	INF	1	4.5	4.5	99.90	99.4	179.8
6GR114	0	0.0	INF	2	.4	.2	99.99	98.9	90.0
6GR115	0	0.0	INF	0	0.0	0.0	100.0	100.0	INF
6GR116	0	0.0	INF	0	0.0	0.0	100.0	100.0	INF
6GR118	0	0.0	INF	2	1.0	.5	99.98	98.9	90.0
6GR119	0	0.0	INF	1	.8	.8	99.98	99.4	180.0
6GR120	0	0.0	INF	0	0.0	0.0	100.0	100.0	INF
6GR231	0	0.0	INF	0	0.0	0.0	100.0	100.0	INF
ANGELS CAMP									
SUMMARY	0	0.0	INF	9	8.6	1.0	99.98	99.4	180.0
	AVERAGE FOR MONTH			0	0.0	0.0	100.00	100.00	INF
1GR1124	0	0.0	INF	2	.9	.5	99.98	98.9	90.0
1GR6025	0	0.0	INF	0	0.0	0.0	100.0	100.0	INF
1GR6026	0	0.0	INF	1	.0	.0	100.00	99.4	180.0
1GR6027	0	0.0	INF	1	1.7	1.7	99.96	99.4	179.9
1GR6028	0	0.0	INF	0	0.0	0.0	100.0	100.0	INF
6GR110	0	0.0	INF	1	.9	.9	99.98	99.4	180.0
6GR111	0	0.0	INF	0	0.0	0.0	100.0	100.0	INF
6GR112	0	0.0	INF	1	.4	.4	99.99	99.4	180.0
6GR113	0	0.0	INF	1	1.7	1.7	99.96	99.4	179.9
FALLON									
SUMMARY	0	0.0	INF	7	5.6	.8	99.98	99.5	231.4
	AVERAGE FOR MONTH			0	0.0	0.0	100.00	100.00	INF
1GR1125	0	0.0	INF	3	6.3	2.1	99.85	98.3	59.9
6GR122	0	0.0	INF	0	0.0	0.0	100.0	100.0	INF
6GR123	0	0.0	INF	0	0.0	0.0	100.0	100.0	INF
6GR124	0	0.0	INF	0	0.0	0.0	100.0	100.0	INF
FERNDALE									
SUMMARY	0	0.0	INF	3	6.3	2.1	99.96	99.5	239.9
	AVERAGE FOR MONTH			0	0.0	0.0	100.00	100.00	INF
1GR1091	0	0.0	INF	2	.4	.2	99.99	98.9	90.0
1GR6453	1	.05	30.0	4	1.3	.3	99.97	97.8	45.0
6GR103	0	0.0	INF	0	0.0	0.0	100.0	100.0	INF
6GR105	0	0.0	INF	0	0.0	0.0	100.0	100.0	INF
6GR106	1	2.00	29.9	1	2.0	2.0	99.95	99.4	179.9
6GR107	0	0.0	INF	0	0.0	0.0	100.0	100.0	INF
6GR108	0	0.0	INF	10	3.2	.3	99.93	94.6	18.0
6GR109	0	0.0	INF	0	0.0	0.0	100.0	100.0	INF
FRESNO									
SUMMARY	2	2.05	120.0	17	7.0	.4	99.98	98.8	84.7
	AVERAGE FOR MONTH			2	2.1	1.0	99.96	99.2	120.0
1GR1042	0	0.0	INF	0	0.0	0.0	100.0	100.0	INF

(Source: Pacific Telephone)

Exhibit 4-II

ILLUSTRATIVE SIX-MONTH MTBO PERFORMANCE
DATA FOR ZOA

INDIVIDUAL CIRCUIT PERFORMANCE

Six Month MTBO

- Oakland Area -

1GR1042	LOS ALTOS	999	1GR1053	MT TAMALPAIS	90
1GR1043	LOS ALTOS	999	1GR1091	FRESNO	90
1GR1051	MT TAMALPAIS	999	1GR1124	FALLON	90
1GR1090	MT TAMALPAIS	999	1GR6031	RENO	90
1GR6018	SACRAMENTO	999	1GR6032	RENO	90
1GR6025	FALLON	999	1GR779	TONOPAH	90
1GR6028	FALLON	999	1GR780	RED BLUFF	90
1GR6029	RENO	999	6GR114	ANGELS CAMP	90
1GR6030	RENO	999	6GR118	ANGELS CAMP	90
1GR6036	PRIEST MT	999	6GR93	LOS ALTOS	90
6GR103	FRESNO	999	1GR1081	ANGELS CAMP	60
6GR105	FRESNO	999	1GR1092	PRIEST MT	60
6GR107	FRESNO	999	1GR1125	FERNDALE	60
6GR109	FRESNO	999	1GR953	RED BLUFF	60
6GR111	FALLON	999	6GR101	TONOPAH	60
6GR115	ANGELS CAMP	999	6GR751	RENO	60
6GR116	ANGELS CAMP	999	6GR97	RED BLUFF	60
6GR120	ANGELS CAMP	999	1GR6463	FRESNO	45
6GR122	FERNDALE	999	1GR1021	PRIEST MT	36
6GR123	FERNDALE	999	6GR90	LOS ALTOS	36
6GR124	FERNDALE	999	6GR251	RED BLUFF	26
6GR231	ANGELS CAMP	999	1GR1019	PRIEST MT	18
6GR98	RED BLUFF	999	6GR108	FRESNO	18
1GR1020	PRIEST MT	180	1GR1047	TONOPAH	83
1GR1052	MT TAMALPAIS	180			
1GR1126	RENO	180			
1GR6026	FALLON	180			
1GR6027	FALLON	180			
1GR6401	ANGELS CAMP	180			
1GR6451	UKIAH	180			
1GR6452	UKIAH	180			
1GR6453	UKIAH	180			
1GR6454	UKIAH	180			
6GR106	FRESNO	180			
6GR110	FALLON	180			
6GR112	FALLON	180			
6GR113	FALLON	180			
6GR119	ANGELS CAMP	180			
6GR754	RENO	180			

Exhibit 4-12
 FAA - PREPARED COMPARISON OF WESTERN REGION RCAG RELIABILITY TO
 NATIONAL AVERAGE RELIABILITY

IMPAC
 IMPROVED MANAGEMENT PERFORMANCE APPRAISAL CONCEPT

APRIL 1974 THRU APRIL 1975

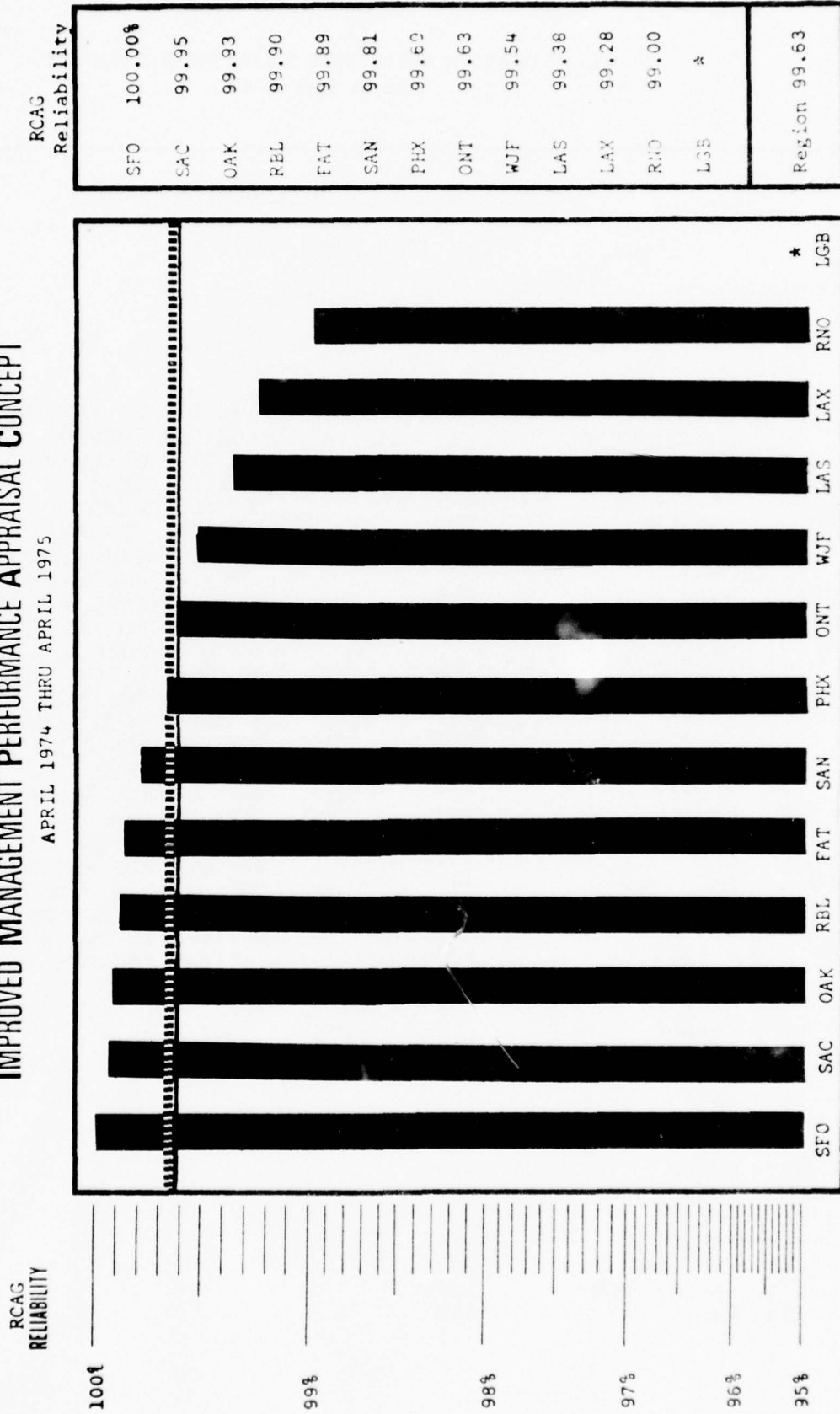

CY 1974 National Reliability 99.67

* NO FACILITY TYPE

Part Two

NAS RADIO SYSTEM PERFORMANCE
OBJECTIVES

5. Air/Ground System Improvement
6. Impact of Related Programs
7. Air/Ground Radio System Performance
Objectives

5

AIR/GROUND SYSTEM IMPROVEMENT

5.1 GENERAL

The FAA's Air/Ground Radio System provides an essential communications link related directly to air travel safety. Under the concept of ground-controlled regulation of aircraft activity, the control channel between air traffic controller and pilot functions as the sole method of controlling air traffic. Lapses or inability to communicate may create control problems affecting all aircraft in the area.

The current reporting system does not identify and isolate the reliability of the various component elements of air/ground communications, making it difficult to quantitatively assess specific performance. This lack of performance data creates uncertainty in air/ground operations and leads to excessive reliance on multiple backup arrangements of facilities.

Furthermore, the FAA's radio communications system has evolved over many years, to the point where it is now comprised of a basic structure, approaching obsolescence, that has been augmented by numerous subsystem and equipment changes which have never been optimized from the total system point of view for cost or performance. While major innovations in computer processing and automation have been introduced to the en route and terminal control site operations (e.g., NAS and ARTS), the air/ground communications have remained essentially static, with equipment and addition of facilities being done in terms of an unchanged system technology. The fact that operations are still carried out successfully may be attributed to the following:

- The airspace has been extensive enough to absorb breakdown and errors in communications.
- Critical ATC communications are made highly redundant by offering two or more options for air/ground communications.
- Pilots, controllers, and maintenance personnel have been able to adapt to difficult communications occurrences.

Such attributes are not attractive for the long term. The airspace is becoming more crowded due to greater numbers of aircraft and higher aircraft speeds. Redundancy is expensive and, if overdone, can actually reduce system availability. Skilled labor categories such as pilots, controllers, and maintenance staff are also expensive and subject to eventual workload saturation.

The goals of a program designed to increase the responsiveness of air/ground communications and yet to contain the costs of operations and maintenance are the following:

- (1) Optimize System Reliability--That is, design the redundancy of subsystems such that the overall system availability requirements are met with the least number of component elements.
- (2) Introduce Automation--Implement computer processing for those operations and maintenance tasks that are susceptible to logical operations and switching.
- (3) Optimize System Utilization--That is, minimize, in absolute terms, the number of radio sites, remoting communication circuits, radio equipments, antennas and control site positions, consistent with the required communications performance.
 - (a) Radio coverage. UHF/VHF operations are line-of-sight; this places limitations on reduction of facility locations.
 - (b) Radio Equipment. The close packing of radio equipments in combined facilities is limited by the radio frequency environment in terms of interference and related signal distortion.

- (c) Automation. The degree of automation employed is self-limiting in that the complexity of hardware and software can outweigh the cost savings in manpower and actually require more manpower with different skills.

The following sections identify areas of potential improvement that lie within the guidelines discussed.

5.2 ATC SYSTEM RESPONSE

Air Traffic Control is based upon an information and control loop between aircraft and controller. The loop traverses the following elements in series:

- (1) Surveillance sensor (ATCRBS; ASR; ARSR)
- (2) Surveillance communications (RML)
- (3) Surveillance processing and display (NAS; ARTS)
- (4) Air traffic controller
- (5) Control position (Communications Terminal)
- (6) Remote communications (line or link)
- (7) Radio facility
- (8) Air/Ground Radio Propagation Channel
- (9) Pilot/aircraft radio subsystem

The response time around the loop, T_r , represents a measure of elapsed time between the sensor event occurring at time, t_o , and the response of the pilot to a communications transaction. In order to operate effectively, the loop must be traversed in real time so that correlation is maintained between surveillance and air/ground communications (i. e., each control instruction is based upon the currently reported position of the aircraft).

Instead, current air/ground communications are manual operations that incur elapsed times inconsistent with the loop response times required for reliable separation assurance. It is evident that errors in communications transactions or missed communications result in either incorrect pilot/aircraft response or no response. In either instance, the information and control loop must be traversed a second time.

Improvement in response time for air/ground communication operations can be attained by introducing automated processing and digital data communications; such an improvement will make communications consistent with surveillance operations in terms of response time.

The DABS/IPC Program is designed to introduce data communications capability between controller and aircraft. A similar compatible capability should be introduced to the VHF/UHF NAS Radio System.

5.3 AVAILABILITY/RELIABILITY/MAINTAINABILITY

The continuity of air/ground communications system operations is dependent upon the relationships established among the parameters of availability/reliability/maintainability, expressed in terms of percentage availability, mean time between failure (MTBF), and mean time to repair (MTTR). These parameter requirements for continuous air/ground system availability are interdependent functions of the various elements that are connected in series to make up the air/ground system. Therefore, optimizing single elements in isolation from the others is non-productive; the entire system must be analyzed and evaluated in order to develop the appropriate relationships.

Improvement in the establishment of system and subsystem availability/reliability/maintainability parameters will have an effect upon both system performance and system cost. The present organization of redundancy is unbalanced and in some cases excessive. For example, there is a one-to-one backup on radio equipment and each backup pair shares a single voice frequency signaling system. A more balanced approach is needed.

5.4 STANDARDIZATION

From the overall air/ground communications system point of view, En Route, Terminal and Flight Service Communications perform essentially identical operations. These three services have evolved relatively independently of each other, with the result that, although similar equipments and techniques are utilized, there exists no uniform standardization program applicable to all three. A further examination

of the radio equipments in use shows that a modernization program that implements the use of solid state equipment is underway for en route facilities (RCAGs). However, the extension of that program to Terminal and FSS communications is less certain. An example of an assignment of radios for Terminal Communications is shown in Exhibits 5-1 and 5-2. Exhibit 5-1 shows the equipment at a New York Kennedy Airport RT (RT # 1). Dates of purchase are shown for each equipment. Exhibit 5-2 shows the corresponding receiver equipment. It is evident that the ages and variety of radio equipment installed and operating cover an extensive range. The diverse sizes and electrical characteristics of all of these equipments necessarily affects radio system performance, maintenance, and logistics.

Utilization of standardized system configurations as well as standardized sub-systems and equipments will obviously benefit FAA operations--maintenance, performance, and cost. In fact, such standardization is a prerequisite to the introduction of automated maintenance of radio facilities, since the diversity of equipments in current use would defeat any attempt to monitor performance automatically.

5.5 RADIO COVERAGE

Effective air traffic control depends upon the availability of communications coverage over the controlled airspace. Ideally, it would be desirable to support radio communications throughout the entire airspace, from the surface up to all flight levels. Realistically, there is a compromise; line-of-sight radio coverage is provided to cover the airways and terminal areas.

Moreover, radio coverage is a function of the power levels utilized and the propagation conditions encountered. Over most of the U.S., terrain variations introduce obstructions which produce incomplete coverage at low altitudes. Additionally, gaps in coverage exist in many areas due to interference cancellation caused by multipath propagation of radio signals from the surface, as well as from various reflecting objects in proximity to the antenna.

Improvement in radio coverage can be attained by more effective utilization of current sites, by the addition of new sites, and by minimization of propagation pattern distortion. Gapless radio coverage for each radio facility over controlled

Exhibit 5-1

JOHN F. KENNEDY RT RACK LAYOUT - TRANSMITTER EQUIPMENT

CONTROL LINE	CO-AX RELAY/ RF BODY PANEL	TV-28 XMTR 123.9 MC #1 (1961)	CO-AX RELAY/ RF BODY PANEL	TV-28 XMTR 120.8 MC #1 (1961)	CO-AX RELAY/ RF BODY PANEL	TV-28 XMTR 123.7 MC #1 (1961)	CO-AX RELAY/ RF BODY PANEL	TV-6 XMTR 127.05 MC #1 (1956)
	JACK PANEL	TV-18 XMTR 121.9 MC	TV-28 XMTR 120.8 MC #2 (1956)	TV-3 XMTR 123.7 MC #2 (1954)	TV-6 XMTR 120.8 MC #2 (1956)	TV-6 XMTR 127.05 MC #2 (1956)		
REPEAT COIL	TV-E XMTR 121.9 #2 (1950)							
RACK	TV-15 XMTR 123.9 MC #2 (1958)							

Exhibit 5-1

JOHN F. KENNEDY RT RACK LAYOUT - TRANSMITTER EQUIPMENT (CONT.)

CO-AX RELAY/ RF BODY PANEL
TV-28 XMTR 119.1 MC #1 (1961)
TV-15 XMTR 119.1 MC #2 (1958)

CO-AX RELAY/ RF BODY PANEL	CO-AX RELAY/ RF BODY PANEL	CO-AX RELAY/ RF BODY PANEL	CO-AX RELAY/ RF BODY PANEL
T-282 E/GR XMTR 269.4 MC #1 (1954)	T-282 E/GR XMTR 256.9 MC #1 (1954)	T-282 E/GR XMTR 388.0 MC #1 (1954)	T-282 E/GR XMTR 348.6 MC #1 (1954)
T-282/GR XMTR 269.4 MC #2 (1954)	T-282/GR XMTR 256.9 MC #2 (1954)	T-282/GR XMTR 388.0 MC #2 (1954)	T-282/GR XMTR 348.6 MC #2 (1954)
DIST. PANEL	DIST. PANEL	DIST. PANEL	DIST. PANEL
MD-141C/GR MOD. PWR. SUPPLY 269.4 MC #1	MD-141C/GR MOD. PWR. SUPPLY 256.9 MC #1	MD-141C/GR MOD. PWR. SUPPLY 388.0 MC #1	MD-141C/GR MOD. PWR. SUPPLY 348.6 MC #1
MD-141/GR MOD. PWR. SUPPLY 269.4 MC #2	MD-141/GR MOD. PWR. SUPPLY 256.9 MC #2	MD-141/GR MOD. PWR. SUPPLY 388.0 MC #2	MD-141/GR MOD. PWR. SUPPLY 348.6 MC #2

airspace can be attained by the optimal use of radio siting characteristics (including the location and number of sites) and the siting criteria at each site.

5.6 RADIO SERVICE UTILIZATION

Currently, the average utilization of radio facilities and services is low, something less than 10%. Or, from another point of view, these radio facilities and services are idle 90% of the time. The utilization of redundant elements (e. g., radio equipment and leased circuit backup) is correspondingly lower--less than 1%.

A further contributor to deteriorated radio facility utilization is the practice of locating several sites, each performing different en route, terminal, or flight service functions, in proximity to one another. While the several facilities exhibit similar radio coverage characteristics, they each possess separate locations, shelters, equipments, leased circuits, logistics, and maintenance services.

It appears that substantial improvement in radio service and facility utilization can be attained by combining site locations and services, and by sharing equipments and leased lines. Such close packing of facilities and equipments is optimal in terms of cost. Since coverage requirements dictate the number and location of radio facilities, the close packing design must satisfy the coverage constraint. However, despite this limitation, potential exists for the reduction in number of facilities, equipments, and leased lines employed (both primary and backup). Furthermore, the cost savings carry over into the maintenance and logistics areas, because fewer facilities and equipments are in the inventory.

5.7 RADIO FREQUENCY ENVIRONMENT

The air/ground radio system employs a fixed number of radio frequencies assigned for use on the basis of frequency separation criteria that ensure interference-free operations. Nonetheless, the 50 kHz and planned 25 kHz channel spacing results in interfering signals appearing on the desired channel assigned frequency due to co-channel interference, adjacent channel interference, and various forms of intermodulation products and spurious emissions.

Furthermore, the received radio signal is subject to distortion and attenuation due to propagation conditions along the radio path and in proximity to the antenna configuration. For example, severe nulls in coverage can occur due to in-phase reflections of radio signals from structures in proximity to the antenna. This condition is particularly evident at co-located radio/radar sites (e.g., BUEC) where communications antennas are mounted on the radar platform in proximity to the radar antenna.

An improved radio frequency environment will provide more effective radio coverage and will minimize interference and distortion of signals.

A trade-off exists between reducing the overall number of facilities and increasing the number of radio channels that may be accommodated at a single site. However, within the limits imposed by frequency management considerations, it appears feasible to close pack radio channels beyond the current level. A key factor in increasing the density of radio channels within a facility is the reduction in the number of antennas, made possible by employing various hybrid configurations such as TR switches, filter combiners, and multicouplers.

5.8 AUTOMATED MAINTENANCE

Air/ground radio maintenance costs far outweigh all other recurrent costs associated with the air/ground radio system. A substantial portion of maintenance time is expended in routine repetitive tasks which appear assignable to computer processing. Also, since considerable site travel is necessary to visit the RCAGs, labor costs are further aggravated by the expense of travel time (which can be either scheduled or unscheduled).

The considerable record-keeping tasks associated with air/ground radio are a concomitant of maintenance operations. Currently, it is difficult to assess air/ground communications performance because of the lack of readily available statistical data describing the inventory of equipment and its performance.

The introduction of automatic performance monitoring, automatic system control, and automatic record generation and reporting would result in the potential for

achieving a highly effective and responsive maintenance operation.

The effectiveness of the maintenance operation based upon achievable mean time to restore service and mean time to repair, has a direct impact on radio service availability. For an automated performance-monitoring and radio-control system, the mean time to restore service should approach zero (assuming parallel, redundant subsystem elements). The achievable mean time to repair, or maintainability, should approach a time essentially close to site travel time plus administrative time. Such a MTTR is feasible because of the automatic performance monitoring, which results in fast reporting of faults. The actual repair time of subsystems is minimal because replacement procedures are substituted for diagnostic analysis and component repair (which are accomplished at a main depot).

5.9 AUTOMATED OPERATIONS

Radio operations for air/ground communications consist of a number of manual control operations followed by sequential speech transmissions. A large percentage of a controller's operations and communications transactions are either logical closures (e.g., push to talk), or alphanumeric transfers (e.g., AA-123). Such operations are completely consistent with digital operations and communications. For example, in a digital system, the voice command "climb to Flight Level 200" could be expressed alphanumerically as "200↑."

Exhibit 5-3 shows a sample distribution of alphanumerics as applied in ATC operations. The sample was compiled from recorded air/ground communications. A vocabulary of 779 words in a total word usage of 9,408 was recorded. Of the 9,408 words employed, 2,131 were alphanumerics. It is evident that these transactions, as well as closures associated with PTT operation and Main-Standby equipment selection, could be more effectively handled via digital communications. The occurrence of message error can be eliminated by error-detection coding, and the signal may be regenerated for noise cleaning at intermediate points in the communications path (e.g., at the remote radio facilities).

The introduction of a degree of automated communications and radio control operations will result in increased controller productivity (i.e., in terms of more aircraft handled).

Exhibit 5-3

ALPHANUMERICS DISTRIBUTION

Communication	Frequency of Use
Aircraft Direction	211
Aircraft Identification	954
Aircraft Speed	39
Airway	90
Altitude	346
Barometric Pressure	15
Beacon Code	76
Distance	44
Gate Identification	13
Hangar Identification	8
Radio Frequency	116
Runway Identification	140
Time	46
Wind Direction	17
Wind Speed	16
TOTAL	2131

Source - Unpublished A/G Language Analysis - INTRADYN

5.10 COST CONSIDERATIONS

Examination of the described areas of improvement demonstrates that most of the improvements involve increased utilization of facilities and personnel which must result in a cost reduction. The exception is the suggestion to introduce automation for both operations and maintenance.

Here it is anticipated that the increased cost of processing will be more than offset by redistributed levels of manpower or increased productivity.

6

IMPACT OF RELATED PROGRAMS

6.1 GENERAL

Air/ground communications is a service responsive to the requirements of National Airspace System operations. The Air/Ground System also supports the following goals of the Upgraded Third Generation (UTG) System:

- To increase and improve performance
- To maintain or improve safety
- To constrain or reduce costs

Exhibit 6-1 lists the principal features of the UTG ATC System. With the exception of MLS, all the programs listed depend upon the support of air/ground radio services. This illustrates the importance of air/ground communications. In particular, the automated portions of the various programs require fast response air/ground service by digital communications which can interface with the processing operations.

In terms of impact on the design of future air/ground service, the following programs must be considered and related to the air/ground system design:

- Flight Service Station Program (FSS)
- Aircraft Separation Assurance Program (ASAP)
- Discrete Address Beacon System (DABS)
- Intermittent Positive Control (IPC)

Exhibit 6-1

PRINCIPAL FEATURES OF UTG ATC SYSTEM

- Intermittent Positive Control (IPC)
- Discrete Address Beacon System (DABS)
- Flight Service Stations (FSS)
- Upgraded ATC Automation
- Airport Surface Traffic Control (ASTC)
- Wake Vortex Avoidance System (WVAS)
- Area Navigation (RNAV)
- Microwave Landing System (MLS)
- Aeronautical Satellites (AEROSAT)

6.2 FLIGHT SERVICE STATION PROGRAM

A three-phase program for a new Flight Service Station system is underway which is intended to modernize, automate, and improve flight service operations. The concept is built around a relatively small number of FSS Hubs (co-located with the ARTCCs) which will provide services through an automated network of remoted input and output terminals. The three phases of this program are Near-Term (1976-1980); Intermediate-Term (1980-1985); and Long-Term (beyond 1985).

Current FSSs perform a number of in-flight support services through the remote air/ground radio outlets located at the FSSs and peripheral communications sites.

The major impact of the FSS program upon air/ground communications services results from the extensive remoting required by placing FSS-Hubs at the ARTCCs. Currently, each FSS operates an air/ground radio service through its own facility, augmented by satellite radio outlets--RCOs, LRCOs, SFOs. The impact is emphasized by the fact that current FSSs perform monitoring and control services for FAA NAVAIDS. A total of 622 VORTAC Facilities, 187 VORs and 3 TACANS are owned and operated by the FAA. Of 187 VORs, 64 are monitored by ATCTs and 123 by FSSs. All 622 VORTACs and the 3 TACANS are monitored by FSSs. Of the 849 VORs and VORTACs, 822 currently possess voice communication capabilities (not all of these are presently used as LRCOs).

In addition to FSS en route communications service via air/ground radio, there are 114 Transcribed Weather Broadcast (TWEB) sites that provide broadcast recordings of aviation weather over the L/MF or VOR facilities. Thirty-eight VOR sites provide TWEB broadcast outlets in the current network. The air/ground radio service is related directly to the NAVAID monitoring and control service since the remoting communications links are shared for both services.

All of these currently existing capabilities for: 1) en route air/ground radio communications, 2) TWEB broadcast, and 3) NAVAID monitoring and control will have to be retained or improved within the planned configuration of FSS-Hub facilities. Moreover, since low-altitude radio coverage is not complete in many

areas, additional improved coverage is desirable as an integral part of any new configuration.

The repeated utilization of the few assigned FSS radio frequencies also presents problems of signal interference. It appears that a logical network of controlled access radio frequency utilization is required to minimize the occurrence of RFI.

Finally, the operation, control, and maintenance of the planned configuration of residual FSSs, VORs, VORTACs, RCOs, LRCOs, and SFOs present a formidable problem in FSS-Hub communications management.

Under the concept of an optimized NAS radio service, it is evident that a substantial portion of the required radio coverage for FSS operations may be provided by the current en route, low-altitude facilities (i. e., RCAGs). Since the FSS may reduce the need for face-to-face briefings for airmen, its location can be dictated solely by radio coverage requirements. There are substantial advantages to close packing FSS air/ground services within the en route air/ground facility, in terms of cost savings in real estate, shelters, radio equipments, leased lines, maintenance, and logistics.

It is also evident that the number of positions required at the FSS-Hub for interface with the current FSS complex of facilities (FSSs, RCOs, LRCOs, SFOs) will be expensive in terms of leased lines, terminal (i. e., control site) equipment and manpower. Instead, a logically switched network of remoted facilities that provides the required service at minimal cost is indicated.

These considerations that shape a response to the new Flight Service Station System requirements are more fully explained in Part Four of this report.

6.3 AIRCRAFT SEPARATION ASSURANCE PROGRAM (ASAP)

The ASAP has been established within the FAA to ensure the orderly planning and development of procedural, regulatory, and equipment alternatives which will significantly increase protection against midair collision.

Analysis of past midair incidents shows the following major causative factors:

- Presence, location, or altitude of one or both aircraft not known to the controller (i. e., surveillance and communications deficiencies).
- Split ATC responsibility (i. e., altitude of aircraft involved unknown to the controller in the adjoining sector).
- Inability to communicate with aircraft involved in the conflict (i. e., aircraft not under control of ATC).

Air/ground communications provide the crucial link for separation assurance and air traffic control. Any program for separation assurance necessarily has an impact upon the future planning and system design of the air/ground radio service.

The goal of the ASAP is to provide an increased level of protection to the maximum number of flights by eliminating the known deficiencies of the present ATC system. The program is phased to allow an orderly implementation of increased capability.

(1) Near-Term (1976-1978)

- (a) Expand conflict alert to provide increased backup to controllers.
- (b) Require all public transportation aircraft to operate in accordance with IFR procedures whenever possible, in order to ensure the utilization of available separation services.

(2) Mid-Term (1978-1984)

- (a) Extend surveillance to ensure coverage in airspace used by large capacity public transportation aircraft (wide-body jets).
- (b) Expand requirements for ATCRBS transponders and altitude encoders to enhance the capability of the surveillance system, and to form the foundation for the Beacon Collision Avoidance System (BCAS).
- (c) Expedite the development of BCAS and make it available to aircraft owners and operators for implementation at their option.

- (3) Long-Term (Post-1980)
 - (a) Proceed with development of DABS/IPC as the optimum long-term solution for providing aircraft separation assurance.

The ASAP provides a phased approach to implementation of three basic separation assurance systems:

- (1) The ground-based ATC system utilizing Conflict Alert Information generated by the NAS-ARTS configurations.
- (2) An airborne beacon-based system (BCAS) that can be utilized by aircraft to reduce the risk of collision.
- (3) The DABS/IPC system for long-term augmentation by the primary ATC system in order to provide protection in mixed airspace (IFR-VFR).

Collision avoidance systems are based upon consideration of the τ parameter representing the time-to-collision for two aircraft on conflicting courses. Modified τ criteria algorithms have been developed to express the escape time available to an aircraft.

$$(1) \quad R + \tau_1 \dot{R} \leq R_{0_1}$$

$$(2) \quad R + \tau_2 \dot{R} \leq R_{0_2}$$

In (1), the τ_1 alarm is conditional upon the designated constants:

$$\tau_1 = 25 \text{ seconds}$$

$$R_{0_1} = 1/4 \text{ nm}$$

In (2), the τ_2 warning is conditional upon the designated constants:

$$\tau_2 = 40 \text{ seconds}$$

$$R_{0_2} = 1.8 \text{ nm}$$

where R = separation range

\dot{R} = separation range rate

The 25-40 seconds represented by τ_1 and τ_2 expresses the loop response time discussed in Part One, Section 2.3, of this report and includes:

- (1) Surveillance data acquisition time
- (2) Surveillance communications time

- (3) Processing time
- (4) Air/Ground communications time
- (5) Controller response time
- (6) Pilot/aircraft response time
- (7) Maneuver time for aircraft

The data acquisition interval is fixed by the ASR or ARSR antenna rotation rate (10-6 rpm), and is 6 seconds in the terminal area. Pilot/aircraft response time is estimated at 13-16 seconds. These intervals total 30 seconds, which exceeds the τ_1 alarm criterion and does not include an interval for controller response time and air/ground communications time.

An analysis performed for the FAA 1982 LAX (Los Angeles Basin) air activity model demonstrates an alarm rate of 5 per minute using the τ_2 criterion.¹ The " $\tau_2 = 40$ seconds" criterion will considerably increase the alarm rate beyond an acceptable level.

In terms of air/ground communications service, this means that essentially zero time is available for controller response and air/ground communications in the performance of CAS operations. The conclusion is that the current voice radio system is inadequate to respond to this requirement. The conflict alert function in the terminal area, where traffic is most dense, requires an air/ground communications service that is automated in its operations and consistent with the automated surveillance and processing subsystems.

If the air/ground radio system is to support aircraft separation assurance systems of the future in a complementary or augmented capacity for DABS, then the radio service must be made compatible with digital processing and communications. This concept is discussed more fully in Part Four of this report.

1. "Review and Analysis of some collision avoidance algorithms with particular reference to ANTC-117." FAA-RD-72.

6.4 DISCRETE ADDRESS BEACON SYSTEM (DABS)

The DABS program provides an improved surveillance capability that will replace the current ATCRBS. The provision of unique interrogation of aircraft minimizes the current problems associated with the over interrogation and ring-around that affects current ATCRBS performance. The DABS will also incorporate a high capacity (4 Mbps) burst data transmission capability that operates as an integral part of the interrogation-response cycle of the beacon system. Ground/air/ground messages may be exchanged during the antenna beam dwell time on an aircraft target. The program will implement DABS surveillance and data link configurations at multiple sites coincident with the current radar locations. DABS facilities will be connected with one another, as well as with Control Sites (ARTCC and TRACON), by a 2,400 bps data transmission system. Since the air/ground channel data rate is 4 Mbps, the digital data transmissions originating at control sites will have to be buffered and stored for transmission at the appropriate time and at the higher rate.

A primary use for DABS data transmission is in response to the requirements for air/ground digital communications to support a number of programs that depend upon real time (zero delay) transactions with aircraft (e.g., CAS, IPC, metering and spacing, etc.).

The impact of the DABS implementation on air/ground radio services centers on the degree of compatibility and interface desired between the two systems. It appears that the air/ground radio system, comprised of over 2000 locations providing communications coverage over the entire airspace, can supply a valuable complementary service to the DABS capability. With feasible and technically demonstrated modifications, the air/ground system can accommodate a 2,400 bps digital signalling mode and thereby interface directly with digital air/ground message sources. This concept is developed more fully in Part Four of this report.

6.5 INTERMITTENT POSITIVE CONTROL (IPC)

IPC is a ground-based collision avoidance system which is to be implemented in the following environment:

- Full x, y, and z surveillance available on all aircraft in the airspace.
- Direct digital data link to displays in the cockpits of aircraft receiving IPC service.
- An automated decision process.

DABS is scheduled to provide the fully automatic surveillance and data link communications capabilities which are a prerequisite to the realization of IPC.

The IPC system will monitor the location, altitude, and velocity of all aircraft in the National Airspace. A ground-based computer will process track (surveillance) data and calculate impending path conflicts between proximate aircraft. When required, the processor will generate proximity warning information and conflict avoidance commands to aircraft. The "intermittent" service is provided only when potential conflict situations are detected by the track processing operator.

The principle use of IPC is to augment normal ATC service. The system will handle three types of encounters between aircraft:

- (1) VFR/VFR
- (2) VFR/IFR
- (3) IFR/IFR (Backup to ATC)

Current IPC planning uses an alarm τ criterion of 30 seconds for type (1) and type (2) encounters. For VFR/IFR encounters, a controller warning is generated at a τ value equal to approximately two minutes, followed by succeeding warnings at 75 seconds, 60 seconds, 45 seconds, and finally the alarm τ at 30 seconds. From the discussion in section 6.3 of this report, it is evident that densely populated environments (i. e., the terminal areas) will generate a large number of warnings and alarms with the above criteria.

IPC will depend upon DABS sensor information for en route and terminal surveillance. Since the en route radar acquisition interval is 10 to 20 seconds,

it is planned to operate en route DABS sensors with back-to-back antennas in order to achieve an acceptable (5-6 seconds) data acquisition interval. The primary radar will continue to operate at acquisition intervals of 10-12 seconds so that radar reinforcement of targets will occur every other scan. The longer ranges involved with en route surveillance and near horizon detection will degrade the positional accuracy of the system, which affects the error distribution and in turn the τ warning tolerance.

The effect of IPC on air/ground communications is consistent with previous discussions of ASAP and DABS. An air/ground service suitably modified to accommodate data communications will interface with the IPC function. The use of voice communications with IPC operations is unacceptable because of the delays incurred by controller response time and communications time.

7

SUMMARY OF AIR/GROUND RADIO SERVICE OBJECTIVES

7.1 GENERAL

The Air/Ground Radio Service supports the safety, performance, and cost objectives of the UTG ATC System. Regarding communications, the goal is to provide a cost-effective operation which fully supports all requirements for Air Traffic Control and Flight Service Operations.

7.2 AIR/GROUND RADIO SERVICE OBJECTIVES

Exhibit 7-1 lists in summary form the objectives that will provide a responsive system configuration for post-1980 operation. The objectives presented may be considered as guidelines for near-term program activity, as well as long-term goals. The parameters for data communications capability are listed as potential options for improved performance that will update the current air/ground system in order to provide service compatible with the requirements of the upcoming UTG Programs. In terms of utility and value related to communications support, it is evident that a voice/data, air/ground system will demonstrate superior cost-effectiveness over the long term.

Exhibit 7-1

NAS RADIO SERVICE OBJECTIVES

■ SAFETY

- Provide A/G Services responsive to all National Airspace requirements for communications support

■ PERFORMANCE

- Radio Coverage over all airspace
- A/G System Availability of 0.9999
- System Response Time
 - 0-2 seconds for system access (voice)
 - *0-4 seconds for data communication (data)
- Signal Quality
 - 95% intelligibility (voice)
 - * 10^{-9} undetected word in error rate (data)

■ COST

- Provide maximum system utilization consistent with required service performance
- Implement automation of functions wherever cost-effective
- Standardize techniques, equipments, facilities, and subsystems
- Maximize efficiency of operations and maintenance

* data transmission options.

Part Three

STUDY AND ANALYSIS APPROACH

8. Summary of Study and Analysis Approach
9. System Design Rationale

8

SUMMARY OF STUDY AND ANALYSIS APPROACH

8.1 GENERAL GUIDELINES

Three principle guidelines were employed in the study approach:

The use of the systems approach

The use of applied design

The use of selective analysis

- (1) Systems Approach. Throughout the study, the basic element for analysis is the air/ground radio system. Although the air/ground system extends over the entire U.S., its primary characteristics of operation are defined by consideration of a Center Area configuration. Within a Center Area, the air/ground subsystem is made up of five elements connected in series:

- (a) Control site
- (b) Line or link
- (c) Radio facility
- (d) Radio propagation channel
- (e) Aircraft radio subsystem

In order to develop a radio facility design concept, it was necessary to examine the facility in the context of its system environment. A central issue involves the number, characteristics, and peripheral equipments associated with the radio equipments at a facility. Such information raises questions regarding co-location of facilities for improved utility; related radio coverage provided by a reduced number of facilities; an

approach to redundant equipments for current configuration in ZOA; apportionment of element reliabilities; and configuration of signalling, control and monitoring subsystems.

Both air/ground systems operations and systems maintenance concepts must be re-examined in the light of the modifications required by the FSS Program in particular and by the other related UTG Programs in general.

Utilizing a systems approach has necessarily required an expenditure of time and effort in interfacing areas within the limited resources available for the study. However, the dilution of effort is more than offset by the advantages gained from establishing the basic framework within which a radio facility must operate.

- (2) Applied Design. Twenty Center Areas exist in the U.S. and operate over 2,000 radio facilities. It was evident from field visits that local areas exhibit different sets of communications problems. It was also evident that a large degree of commonality exists. Rather than engage in an abstract, general design process, it was considered more useful to apply the design to a selected Center Area in order to analyze a realistic situation. Although orientation visits were made to five Regions, the analysis is focused on one Center Area (Oakland-ZOA). Oakland was selected because its irregular terrain probably represents a cross section of all other Center Areas, and because descriptive data are available as supplied by an Oakland TID¹ on assignment to the study for a three-month period.

Those portions of the study that require a practical and realistic assessment of actual conditions utilize the Oakland Center Area as a model for analysis. It is felt that the result may be applied to other Center Areas with appropriate modification.

1. Mr. E. Milani.

AD-A042 514

VERVE RESEARCH CORP ROCKVILLE MD
STUDY REQUIREMENTS FOR AN INTEGRATED AIR/GROUND COMMUNICATIONS --ETC(U)
MAY 77 J HANSEN, A WEBSTER, B REYNOLDS
VS-29

F/G 17/2.1

DOT-FA75 WAI-570

NL

UNCLASSIFIED

FAA-RD-76-154

2 OF 4
AD
A042514



SIFIED

2 OF 4

AD

A042514

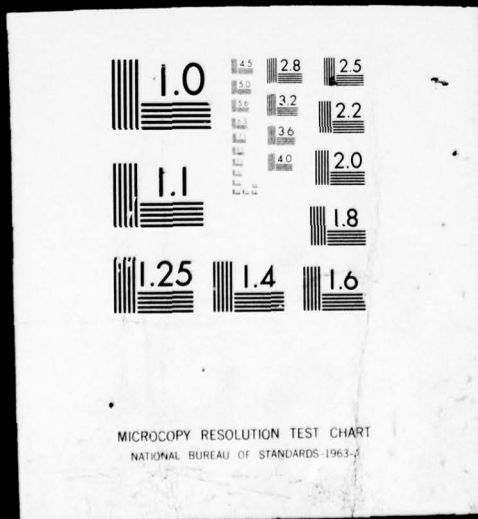

(3) Selective Analysis. During the initial phases of the study effort a priority structure was developed in order to assign relative payoff values as a function of areas analyzed. Large payoff values were associated with primary category problems that influenced the basic operation and maintenance of the air/ground system. For example, several initial investigations of power assessment (e. g. , solar cells), new facility structures, and next generation radio design were abbreviated. These areas, while of general interest, cannot provide substantial radio system performance improvement. Commercial power backed up by the present engine generators appears satisfactory. The present structures and radio equipments (new solid state procurement) also appear adequate for the foreseeable future. Emphasis was placed on the air/ground network structure, automated operations and maintenance, the radio frequency environment, and service availability. The following six areas are analyzed in Part Four of this report:

- (a) Radio Coverage (Chapter 10)
- (b) Availability/Reliability/Maintainability (Chapter 11)
- (c) Air/Ground Radio Network Switching and Control (Chapter 12)
- (d) Automated Facility Maintenance (Chapter 13)
- (e) Semi-Automated ATC operations (Chapter 14)
- (f) Radio Frequency Environment (Chapter 15)

9

SYSTEM DESIGN RATIONALE

9.1 INTRODUCTION

As in any system design, alternatives exist that must be traded-off and selected on the basis of performance and cost. It is desirable to achieve a balance in which the required level of performance is maintained at the least cost. Thus, there are performance penalties associated with an inadequate design and cost penalties associated with over design.

The system design rationale operates to achieve a minimization of system cost with no compromise of required performance. The following specific rationale were employed as guidance for carrying out the various trade-off analyses.

9.2 FACILITY PLACEMENT

The radio system operates with line-of-sight path restrictions. Each radio facility is located according to its required service (i.e., en route, terminal, and flight service) and its required coverage (i.e., high ATC, low ATC, or FSS sector assignment). With the planned FSS modernization program, the location of the FSSs is primarily a function of required radio coverage. Under these conditions, facility placement can be structured to follow a strategy of a minimum number of distinct facilities whose location is based upon the required communications coverage. There are constraints that limit this strategy: 1) It is desirable to employ sites already in existence, if possible, and 2) radio facilities exhibit upper bounds relative to the number

of equipments accommodated and the number of radio frequencies operated in close proximity. However, under these conditions it would be feasible to implement a radio site minimization program that selects "best" coverage locations and incorporates en route, terminal, and flight service functions within these sites, as required.

9.3 AIR/GROUND NETWORK STRUCTURE

Since remotely located radio facilities require a substantial recurring investment in remote circuits for signaling and radio control, it is important to examine methods for minimizing the annual cost of leased circuits. As general guidance, it is evident that the least total of circuit mileage will be cost-effective. There are a number of methods to attain reduced circuit mileage:

- Locate radio facilities as closely as possible to the host control site-- within the constraint of required coverage.
- Design efficient redundancy of circuits to provide required availability of service.
- Distribute line switching locations so as to minimize total circuit mileage.
- Implement line sharing to the maximum extent consistent with required performance.
- Close pack radio facilities to the maximum extent, so that more effective redundancy ratios of backup circuits may be employed.

9.4 RELIABILITY

The air/ground communications subsystem consists of the following five elements in series:

- (1) Control site
- (2) Line or link
- (3) Radio facility
- (4) Radio propagation channel
- (5) Aircraft radio

These elements exhibit a subsystem reliability that is the product of the five element reliabilities. As a general rule, it is optimum to apportion element reliabilities such that each demonstrates an equivalent reliability. Therefore, it is important to design element reliability so that overall subsystem availability of service is attained without assigning excess and expensive reliability to one or more elements. Of the five elements in series, the control site, the line or link, and the radio facility may incorporate redundant parallel elements, resulting in improved availability of service assuming maintainability, i.e., a mean time to repair. The radio propagation channel may be designed for a channel reliability with no capacity for parallel redundant channels, i.e., no provision for space or frequency diversity. The aircraft radio system normally consists of two sets of equipments which exhibit a fixed reliability with no provision for maintainability (while in flight). It is evident that the radio channel and the aircraft radio subsystem are limiting factors in the attainment of total air/ground radio subsystem service availability.

9.5 STANDARDIZATION

The maximum degree of cost-effective operations follows a program of system standardization. This is a result of the gains realized in purchase, operation, maintenance, and logistics of the minimum number of diverse equipments. The degree of standardization should be chosen to meet all performance requirements and also provide growth potential.

9.6 AUTOMATION

Air/ground radio service is currently labor intensive, with substantial costs associated with operations and maintenance personnel. The introduction of automation to increase labor productivity is desirable. Additionally, the incidence of system error will also decrease with machine operations. Finally, the system response time in terms of both communications operations (e.g., by data link), and maintenance operations (automatic fault isolation and service restoral) will decrease.

9.7 FACILITY UTILIZATION

Duty cycles or load factors associated with the air/ground radio system are relatively low and correspondingly cost-ineffective. Methods for increasing utilization without compromising performance are desirable. The current use of one-to-one backup for radio equipments, dual circuits for UHF/VHF ATC, and one-to-one backup for leased lines (i.e., LASS) appears excessive in terms of low utilization. Additionally, the use of multiple radio facilities within one local area (e.g., a few miles) is unwarranted in terms of maximum facility utilization. As a general rule, it is cost-effective to employ a minimum number of sites and a minimum number of equipments and circuits to achieve increased system utilization.

Part Four

ANALYSIS AND EVALUATION

10. Radio Coverage
11. Availability/Reliability/Maintainability
12. Air/Ground Radio Network Switching and Control
13. Automated Facility Maintenance
14. Semi-Automated ATC Operations
15. Radio Frequency Environment

10

RADIO COVERAGE

10.1 INTRODUCTION

Air/ground radio coverage is the single most important system design parameter in the determination of system characteristics. The placement of remote radio facilities must provide reliable communications with aircraft operating anywhere in the airspace. With the various collision avoidance systems planned for future operations as part of the Aircraft Separation Assurance Program (ASAP), it is particularly important to insure coverage over mixed (i.e., VFR/IFR) airspace. The determination of radio coverage is an approximation process that can only be verified by experimentation. The principal problem in providing coverage occurs at low altitudes over nonsmooth terrain where propagation paths are affected by multiple reflections and obstacles (natural and man-made).

This study focused its attention on a radio coverage analysis for one Center Area (Oakland-ZOA), in order to examine the potential possibilities of co-location and the minimization of facilities. Oakland provides a challenging coverage problem because of the range of elevation from sea level to 15,000 feet.

A Center Area is composed of an ARTCC (control site for en route ATC); a number of ATCTs/TRACONS (control sites for terminal ATC); and a number of FSS-controlled facilities (FSS, RCO, LRCO, SFO) for provision of flight services. For this analysis, it is assumed that the FSS-Hub area of respon-

sibility coincides with the Center Area boundary, although the determination of FSS-Hub areas has not been finalized.

Radio coverage must satisfy the requirements for ATC communications with assigned sectors of airspace, both en route and terminal, and for flight service communications, primarily with VFR aircraft operating below 18,000 feet. The en route ATC sectors for ZOA are stratified into two altitudes: low (to 24,000 feet) and high (above 24,000 feet). Terminal airspace sectorization is a function of the service provided, i.e., approach control, local control, etc. However, a service range of 60 nautical miles and an altitude to 25,000 feet includes all functions. Exhibit 10-1 shows the service volume dimensions.

10.2 METHODOLOGY

Four inputs were employed as integral parts of the study:

- (1) Sector Service Volumes. The ZOA HAT (high altitude) and LAT (low altitude) Sectors partition the en route airspace. Terminal airspace was based on the appropriate parameters set forth in Exhibit 10-1. A Flight Service airspace was constructed into four sectors that employed boundaries drawn to minimize the cutting off of Vector airways within the Center Area. This FSS sectorization is arbitrary, because the FSS Program has not defined sectors for ZOA.
- (2) Facility Locations. Current locations for RCAGs, BUECs, RTRs, FSSs, LRCOs, and SFOs were employed.
- (3) LOS Radio Coverage. Line-of-site contours, as calculated by ECAC for various altitudes from the surface to 20,000 feet, were used. The ECAC contours are developed on the basis of facility location (latitude and longitude), antenna height, and surrounding terrain. The resulting coverage does not include perturbations caused by man-made obstructions, i.e., buildings, towers, etc.

- (4) Radio Frequency Assignments. The radio frequency assignments for ZOA facilities as listed in WE 6050.1A Change 10: 7/2/75, were used.

For each sector considered, the coverage contours were applied in order to determine the degree of coverage attainable.

Employing the strategy of minimizing the number of locations and employing locations as close as feasible to Oakland ARTCC, sector frequencies were assigned to the radio facilities. Since Terminal Areas require a radio facility on or near the airport to provide surface coverage, it was assumed that the current locations are adequate. However, the integration of RTR complexes within a Terminal Area is a distinct possibility.

Since LRCOs are normally associated with NAVAID facilities, fixed locations of LRCO/VORs were assumed.

10.3 RESULTS

Exhibits 10-2 through 10-4 list the current facilities and sector frequency assignments. The ATCTs are also distinguished between Approach Control (AC) and Non-Approach Control (NA) activities. The Exhibit 10-4 (ZOA FSSs) includes distance to Oakland, function, presence of ATCT, ILS/CDA, and DF (direction finder).

Exhibits 10-5 through 10-21 illustrate the correlation between coverage contours and HAT/LAT Sectors within ZOA. The discussion below applies to the following four situations:

- (1) En Route High Altitude ATC
- (2) En Route Low Altitude ATC
- (3) Terminal ATC
- (4) Flight Services

The discussion is necessarily approximate and does not reflect a total awareness of ZOA radio coverage problems.

10.3.1 En Route High Altitude ATC

High Altitude Coverage for all ZOA HAT sectors appears to be attainable by the utilization of one radio facility located at Mt. Tamalpais (Exhibit 10-5). The contour shown for Mt. Tamalpais represents 20,000 feet and provides coverage over the entire group of high altitude sectors. (The HAT sector floor is at 24,000 feet.) For alternate site coverage in the event of catastrophic failure, i.e., site destruction or cable interruption, a multiplicity of radio facilities is required. Exhibit 10-22 illustrates the assignments of sectors to facilities, while Exhibits 10-5 through 10-11 show the approximate coverage obtained at 20,000 feet. It should be noted that there does not appear to be a requirement for BUEC facilities, except for Red Bluff (Exhibit 10-7), which provides better coverage than the corresponding Red Bluff RCAG.

The mode of operation that is suggested involves the employment of Mt. Tamalpais as a primary HAT facility with the approximate complement of frequencies using fixed frequency equipments. The alternate facilities listed in Exhibit 10-27 would contain tunable transceivers for operation when required.

10.3.2 En Route Low Altitude ATC

Low altitude coverage is highly variable due to the Oakland area terrain. Coverage may range from a few thousand feet in the valleys to 14,000 feet over mountainous areas. A multi-site configuration is necessary to extend coverage into all required sector areas. Exhibits 10-12 through 10-21 illustrate the approximate coverage over the assigned LAT sectors.

Exhibit 10-23 shows the corresponding facility-sector-frequency assignments that appear to provide the required service. A single pair of frequencies (one VHF and one UHF) is used for each sector. In a number of cases, multiple sites are required to provide sector coverage. In these instances, logical switching is provided to utilize the appropriate site (i.e., within coverage of the aircraft).

For secondary coverage in case of catastrophic failure of a primary LAT en route radio facility, it appears to be feasible to place tunable transceivers at

Terminal (RTR) or FSS Complexes (SFO-LRCC)--locations which will be made accessible to the ATC positions at the ARTCC.

A tentative assignment is shown in Exhibit 10-23 for secondary coverage. It is noted that maximum use of current facilities is employed by placing tunable transceivers within the facilities.

10.3.3 Terminal ATC

The terminal ATC coverage was not specifically analyzed since it is evident that on-airport radio facilities are required to provide surface coverage. Additionally, coverage problems at terminals are principally due to man-made obstructions (towers, etc.) that are not treated by the ECAC contours. (However, ECAC contours can be augmented to include the effects of local obstructions, if ECAC is provided with inputs on the characteristics of the obstructions (i.e., location and dimensions). The goal of fewer terminal facilities may be attained by combining RR, RT, and Tower configurations into one or several facilities (see Chapter 15).

10.3.4 Flight Services

Exhibit 10-24 shows the airspace structure of four sectors (A, B, C, and D) utilized for analysis. Also shown are the RCAGs, RCOs, and VOR/LRCC/SFO locations. Whenever possible, the sector boundaries were selected to avoid interruption of airways between terminals.

The four areas shown in Exhibit 10-24 represent what appears to be a feasible approach, since "handoffs" are not required and the traffic activity may be handled by several inflight specialist positions assigned to each sector. Coverage for each FSS Sector was assigned as follows:

- Sector A: Ferndale, Red Bluff (BUEC), Mt. Tamalpais
- Sector B: Red Bluff (BUEC), Fallon, Mina
- Sector C: Angels Camp, Mina, Fresno
- Sector D: Mt. View, Paso Robles (BUEC)

The expected air activity for flight services is unevenly distributed over the four sectors. The number of radio contacts from FSSs for CY-1975 was as follows:

FSS Radio Contacts: CY-1975

Arcadia	60,128	Red Bluff	56,276
Crescent City	17,474	Reno	26,941
Fresno	42,218	Sacramento	43,729
Lovelock	20,122	Salinas	30,592
Marysville	19,446	Stockton	31,417
Montague	11,715	Tonopah	24,002
Oakland	96,720	Ukiah	34,905
Paso Robles	21,093		

The following is an approximated apportionment of radio contacts among the four sectors:

Sector A: 160,000

Sector B: 45,000

Sector C: 70,000

Sector D: 240,000

An approximate loading factor, assuming a uniform distribution, may be estimated by dividing out the annual number of contacts, i.e.,

$$\text{Radio contacts per day} = \frac{100,000}{360} = 278$$

Thus, an average contact of 30 seconds results in:

$$\begin{aligned} \text{Communications time per day} &= 278 \times 30 \text{ (sec.)} = 139 \text{ minutes} \\ &= 2.3 \text{ hours} \end{aligned}$$

A typical distribution of radio contacts is shown in Exhibit 10-25, which indicates that 90% of the contacts occur over a 12 hour period. Thus, an approximate duty cycle for one channel becomes

$$\text{Average duty cycle} = \frac{2.3}{12} = 19\% \text{ for } 100,000 \text{ contacts/year.}$$

The first apportionment assignment of general flight service radio frequencies would be one frequency per 100,000 radio contacts. Additionally, each sector has an emergency frequency and EFAS frequency and the various VOR/IRCO assignments. Exhibit 10-26 illustrates the sector allocation.

10.3.5 Summary of Facility Frequency Assignments

The final results of providing sector coverage for en route (high and low) ATC and Flight Services is shown in Exhibit 10-27 in terms of required frequency assignments.

The following current facilities are not included in Exhibit 10-27.

Priest (RCAG)	Lovelock (FSS)
Tonopah (RCAG)	Marysville (FSS)
Red Bluff (RCAG)	Montague (FSS)
Fallon (BUEC)	Oakland (FSS)
Half Moon Bay (BUEC)	Paso Robles (FSS)
Oakland (BUEC)	Red Bluff (FSS)
Reno (BUEC)	Reno (FSS)
Sacramento (BUEC)	Sacramento (FSS)
Tonopah (BUEC)	Salinas (FSS)
Ukiah (BUEC)	Stockton (FSS)
Arcata (FSS)	Tonopah (FSS)
Crescent City (FSS)	Ukiah (FSS)
Fresno (FSS)	

These exclusions represent a reduction of 25 radio facilities on the basis of the coverage analysis described in this chapter. Gaps in radio coverage that are not apparent from examination of the ECAC contours may exist over the ZOA area. These results are an exercise in methodology that may be applied for future sector-frequency-facility assignments. Any final assignments must be initiated by the specific Region of responsibility, whose experience with the area will modify the results developed.

10.3.6 Cost Considerations

To evaluate the costs involved, sample cost exercises were performed for representative facilities. Exhibit 10-28 shows RCAG costs for Angels Camp, which comprises two separate sites. Exhibit 10-29 shows a cost data summary, with a five site average. Exhibit 10-30 shows a similar cost development for the Fresno Flight Service Station.

It is evident from examination of facility costs that the major portion of recurring costs is assigned to manpower and leased circuits. The capital cost of radio equipment is significant, so that any reduction in the required number of equipments is desirable both from capital cost and recurring cost (maintenance) considerations. The cost figures shown cannot be easily related to cost savings achieved by a 25-facility reduction. The radio frequencies and corresponding equipments assigned to the excluded sites are shifted to other sites where the maintenance load will correspondingly increase. However, some substantial fraction of the capital and annual facility cost will be eliminated with such a reduction in facilities.

Exhibit 10-1

SECTOR SERVICE VOLUME DIMENSIONS

SERVICE	Service Altitude (feet)	Service Range (Nautical Miles)
Precision Approach Radar	*5,000	25
Helicopter Control	*5,000	30
Local Control and VFR Radar Advisory	*10,000	30
Approach Control (Radar or Manual) & ATIS	**25,000	60
Departure Control (Radar or Manual)	**20,000	60
Low Altitude Enroute	**18,000 [#]	60
High Altitude Enroute (VHF)	***45,000	150
(UHF)	75,000	200

*Above terrain

**Above MSL

***Altimeter standard pressure setting (29.92)

#. Service is provided to 24,000 feet at regional discretion case-by-case basis.

Exhibit 10-2

ZOA RCAGs: SECTOR FREQUENCY ASSIGNMENTS

NAME	LOCATION	V/U	SECTOR	d
Angels Camp (2)	38-01-14/120-35-02	120.2 /290.4 133.3 /319.9 132.95/269.1 /296.7	13 L 14 L 32 H 32 TSU	
	38-01-24/120-35/20	120.6 /307.8 124.2 /284.6 128.15/281.5	15 L 25 L 47 H	
Fallon	39-30-13/118-40-12	128.8 /285.5 134.45/269.3 /296.7 132.05/291.7	16 L 33 H 33/34 TSU 35 H	
Ferndale	40-29-51/124-17-37	123.9 /284.7 133.75/319.2 134.35/290.2	18 L 31 H 31 H	
Fresno (2)	36-37-51/119-56-04	123.8 /353.8 128.15/281.5 133.7 /285.4 /296.7	12 L 42 H 45 H 42 TSU	
	36-37-59/119-56-13	126.9 /343.8 128.55/357.6 132.8 /319.1	11 L 42 H 43 H	
Mina	38-33-55/118-01-55	127.45/327.8 132.45/307.3	16 L 34 H	
Mountain View	37-19-08/122-08-45	128.35/343.6 135.0 /317.5 132.65/263.1 126.8 /335.6 126.8 /335.6	22 L 23 L 24 L 50 H 50 L	
Mt. Tamalpias	37-55-37/122-37-40	132.2 /281.4 127.8 /353.5 121.2 /323.0	18 L 26 L 27 L	
Priest	36-08-14/120-39-58	128.7 /307.0 134.7 /387.0 132.8 /319.1 133.5 /290.5	10 L 11 L 43 H 44 H	
Red Bluff	40-06-20/122-14-06	120.4 /306.9 132.2 /281.4 134.35/290.5 132.95/269.1	17 L 18 L 31 H 32 H	
Reno	39-35-11/119-55-49	128.8 /285.5 134.45/269.3	16 L 33 H	
Sacramento * Shared with SAC RTR	38-41-59/121-35-33	127.95/316.1	15 L	
Tonopah	38-06-24/117-11-06	127.3 /319.8 132.05/291.7	16 L 35 H	

Exhibit 10-3

ZOA ATCTs: SECTOR FREQUENCY ASSIGNMENTS

NAME	LOCATION	FUNCTION	V/U	AC	NA	
Chico	39-47-55/121-51-17	GC	121.8		X	
		LC	118.6 /392.0			
		LC	120.15			
Concord	ATCT 37-58-10/122-03-15	EM	121.5		X	
		GC	121.9			
		LC	119.7 /257.8			
	RTR 37-58-23/122-03-07	LC	126.4			
		AT	124.7			
		EM	121.5			
		LC	119.7 /257.8			
		LC	126.4			
Fresno (Fresno Air Terminal)	ATCT 36-46-25/119-43-17	EM	121.5 /243.0	X		
		GC	121.9 /348.6			
		LC	118.5 /251.1			
	RT 36-46-56/119-42-59	AT	119.3			
		EM	121.5 /243.0			
		GC	121.9 /348.6			
		LC	118.5 /251.1			
		LC	135.35			
		AC/DC	119.6 /297.2			
		AC/DC	125.3 /315.6			
VIS RTR 36-19-37/119-23-55	AC/DC	132.35				
Fresno (Chandler)	ATCT 36-46-25/119-42-10 RT 36-44-08/119-49-17	GC	121.7		X	
		EM	121.5			
		LC	121.1 /335.5			
Hayward	ATCT 37-39-31/122-07-38	EM	121.5 /243.0	X		
		GC	121.7 /348.6			
		LC	118.9 /257.8			
		LC	125.8			
	RT 37-39-03/122-07-48	AT	126.7			
		EM	121.5 /243.0			
		GC	/348.6			
	ATCT (Receive only)	LC	118.9			
		LC	125.8			
		RO	122.5			
Lake Tahoe	38-53-43/119-59-50	EM	121.5 /243.0	X		
		GC	121.9			
		LC	118.4 /257.8			
Livermore	37-41-45/121-49-00	EM	121.5	X		
		GC	121.8			
		LC	118.1 /368.7			
Marysville	39-05-47/121-33-55	GC	121.8	X		
		LC	119.3			
Merced	37-17-14/120-30-44	GC	121.8	X		
		LC	121.0 /252.9			
		EM	121.5			
Modesto	37-37-15/120-57-12	EM	121.5 /243.0	X		
		GC	121.7			
		LC	120.0 /257.8			
		(Receive only)	RO			122.5

Exhibit 10-3 (Cont.)

ZOA ATCTs: SECTOR FREQUENCY ASSIGNMENTS

NAME	LOCATION	FUNCTION	V/U	AC	NA
Monterey	ATCT 36-35-16/121-51-06	EM	121.5 /243	X	
		GC	121.9 /348.6		
		LC	118.4 /257.8		
	RT 36-35-05/121-50-24	AC/DC	/309.2		
		LC	118.4 /257.8		
		EM	121.5 /243.0		
		AC/DC	120.8 /263.6		
		AC/DC	127.15/302.0		
Napa	38-12-33/122-16-33	EM	121.5		X
		GC	121.7 /257.8		
		LC	118.7		
Oakland	RT 37-42-46/122-13-29w	AT	128.5	X	
		CD	121.1		
		GC	121.75		
		GC	121.9		
		LC	118.3 /256.9		
		LC	124.9 /395.9		
		LC	126.0		
	RT 37-44-28/122-13-02	AC/DC	120.9 /268.7		
		AC/DC	123.85/307.2		
		AC/DC	124.4 /313.2		
		AC/DC	132.55/317.6		
		AC/DC	133.95/323.2		
		AC/DC	134.5 /338.2		
		AC/DC	135.1 /351.8		
	(Moffett) RTR 37-24-31/122-03-02	AC/DC	135.4 /354.1		
		AC/DC	135.65/257.2		
		AC/DC	/266.8		
		AC/DC	/300.4		
		AC/DC	/310.8		
		AC/DC	/325.2		
(Saratoga) RTR 37-13-25/122-05-30	AC/DC	/328.4			
	AC/DC	/363.6			
	AC/DC	120.1 /322.0			
(San Jose) RT 37-21-18/121-55-35	AC/DC	121.3 /346.0			
	AC/DC	125.35/350.8			
	AC/DC	134.6			
	AC/DC	135.2			
Palo Alto	37-27-27/122-06-50	EM	121.5	X	
		GC	121.9		
		LC	118.6 /257.8		
		RO	122.5		
Redding	40-30-28/122-17-56	GC	121.7	X	
		LC	119.8 /226.3		
Reno	ATCT 39-29-15/119-46-30	AC/DC	119.2 /325.8		
		AC/DC	120.8 /353.9		
		AC/DC	126.3		
	ATCT 39-35-11/119-55-49	EM	121.5 /243.0		
		GC	121.9 /348.6		
		LC	118.7 /257.8		
		AC/DC	119.2 /353.9		
		LC	126.3		
	(Receive Only)	RO	122.5		

Exhibit 10-3 (Cont.)

ZOA ATCTs: SECTOR FREQUENCY ASSIGNMENTS

NAME	LOCATION	FUNCTION	V/U	AC	NA
Reno (continued)	RTR 39-31-53/119-39-18	AT AC/DC EM GC LC	125.8 120.8 /325.8 121.5 /243.0 /348.6 118.7 /257.8		
Sacramento (Executive)	ATCT 38-31-05/121-30-15	AT GC LC	125.5 121.9 119.5 /257.8	X	
(Marysville)	RT 38-30-58/121-29-13 RTR 39-06-11/121-33-52	LC AC/DC AC/DC AC/DC	119.5 /257.8 125.4 /269.6 /327.5 /383.1 /385.6		
(McClellan)	#1 RTR 38-40-10/121-24-57	EM AC/DC AC/DC AC/DC AC/DC AC/DC	/243.0 118.8 /259.1 124.5 /284.0 127.4 /353.7 128.25/363.8 134.1 /372.8 /388.9		
	#2 RTR 38-40-20/121-24-37	EM AC/DC AC/DC AC/DC AC/DC AC/DC	121.5 128.6 /253.5 133.1 /271.3 133.6 /285.6 135.8 /320.1 /340.9 /381.2		
Sacramento (Metropolitan)	RTR 38-41-59/121-35-33	CD GC LC	121.1 121.7 125.7 /256.7	X	
Salinas	36-39-35/121-36-10	EM GC LC	121.5 121.7 119.4 /239.3		X
(AC/DC Monterey)					
San Carlos	37-30-38/122-14-27	AT GC LC	125.9 121.6 119.0 /326.2		X
(AC/DC Oakland)					
San Francisco	ATCT 37-37-10/122-23-00	EM GC GC LC	121.5 121.65 121.8 120.5 /353.9		X
	RTR 37-37-14/122-21-52	CD EM GC GC LC LC	121.4 121.5 121.65 121.8 120.5 /353.9 128.65		
	RTR 37-37-37/122-23-33	GC LC	121.8 120.5		
(AC/DC Oakland)					

Exhibit 10-3 (Cont.)

ZOA ATCTs: SECTOR FREQUENCY ASSIGNMENTS

NAME	LOCATION	FUNCTION	V/U	AC	NA
San Jose (Muni) (AC/DC Oakland)	RT 37-21-18/121-55-35	CD	118.0		X
		EM	121.5		
		GC	121.7		
		LC	120.7 /257.6		
		LC	124.0		
San Jose (Reid-Hillview) (AC/DC Oakland)	37-19-58/121-49-08	AT	125.2		X
		GC	121.8		
		LC	119.8 /257.8		
		LC	126.1		
Santa Rosa (AC/DC Oakland)	ATCT 38-30-36/122-48-26 (Receive Only)	GC	121.9		X
	RT 38-30-52/122-48-24	RO	122.5		
		LC	118.5 /363.0		
Stockton	ATCT 37-53-40/121-14-14	GC	121.9	X	
	RT 37-53-27/121-14-10	AC	125.1 /363.2		
		EM	121.5 /243.0		
		LC	120.3 /239.0		

Exhibit 10-4

ZOA FSSs: FREQUENCY ASSIGNMENTS

NAME	D (miles)	LOCATION	FUNCTION	V/U	ATCT	ILS LDA	DF
Arcata	260.77	FSS 40-58-50/124-06-30 (Receive only)	E	121.5 /243.0		X	X
			AS	123.6			
			RO	122.1			
			FS	122.2			
			FS	122.6			
	260.73 250.09 244.92	BVOR (Transmit only) LRCO (Eureka) LRCO (Fortuna)	TO	110.2			
			TO	122.2			
			TO	114.0			
			RO	122.1			
Crescent City	313.62	FSS 41-46-42/124-14-15	E	121.5 /243.0		X	
			AS	123.6			
			FS	122.2			
			FS	255.4			
			TO	109.0			
	313.78	LRCO	RO	122.1			
Fresno	133.09	FSS 36-46-18/119-43-18	E	121.5 /243.0	X	X	X
			RO	122.1			
			FS	122.2			
			FS	122.7			
			FS	123.65			
	126.12	BVOR	TO	112.9			
			RO	122.1			
			TO	115.6			
	132.38	BVOR (Friant)	RO	122.1			
			TO	112.6			
	86.95	LRCO (Los Banos)	RO	122.1			
			TO	109.4			
	157.18	TVOR (Visalia)	TO	109.4			
RO			122.1				
Lovelock	263.21	FSS 40-12-08/118-27-06	E	121.5 /243.0			X
			AS	123.6			
			RO	122.1			
			FS	122.2			
			FS	122.4			
	252.70 339.61	BVOR LRCO (Sod House)	FS	255.4			
			TO	116.5			
			TO	114.3			
	321.51	LRCO (Winnemucca)	RO	122.1			
			E	121.5			
		FS	122.3				
Marysville	109.22	39-05-49/121-33/57	E	121.5 /243.0	X		
			RO	122.1			
			AS	119.3			
			FS	122.2			
			FS	122.6			
	109.28 104.82 122.21	BVOR BVOR (Williams) LRCO (Maxwell)	FS	255.4			
			TO	110.8			
			TO	114.4			
			TO	110.0			
			RO	122.1			

Exhibit 10-4 (Cont.)

ZOA FSSs: FREQUENCY ASSIGNMENTS

NAME	D (miles)	LOCATION	FUNCTION	V/U	ATCT	ILS LDA	DF
Montague	291.81	FSS 41-47-03/122-28-08	E	121.5 /243.0			
			FS	122.2			
			AS	123.6			
	271.17	LRCO (Fort Jones)	FS	255.4			
			TO	109.6			
			RO	122.1			
Oakland	16.82	FSS 37-43-52/122-13-00	E	121.5 /243.0	X	X	
			FS	122.2			
			FS	122.7			
			FS	255.4			
	16.76	LRCO (Fresno)	EFAS	122.0			
			EFAS	122.0			
			EFAS	122.0			
		LRCO (Red Bluff)	EFAS	122.0			
			EFAS	122.0			
			EFAS	122.0			
		LRCO (Sacramento)	EFAS	122.0			
			TO	116.8			
			BVOR	116.8			
	58.46	BVOR (Pt. Reyes)	TO	113.7			
			TO	113.7			
34.48	BVOR (Sausalito)	TO	110.4				
		TO	110.4				
34.49	LRCO (Concord)	TO	110.6				
		RO	122.1				
47.63	LRCO (Napa)	TO	112.1				
		RO	122.1				
17.49	LRCO (Woodside)	TO	111.4				
		RO	122.1				
Paso Robles	210.24	FSS 35-40-10/120-38-06	E	121.5 /243.0			X
			AS	123.6			
			RO	122.1			
			FS	122.2			
			FS	122.4			
			FS	255.4			
	148.02	BVOR (Avenal)	TO	114.3			
			TO	117.1			
	169.31	LRCO (Priest)	RO	122.1			
			TO	110.0			
	120.07	LRCO (San Luis Obispo)	RO	122.1			
			TO	112.4			
170.68	LRCO (San Luis Obispo)	TO	112.4				
		RO	122.1				
Red Bluff	179.78	FSS 40-09-30/122-15-00	E	121.5 /243.0			X
			AS	123.6			
			RO	122.1			
			FS	122.2			
			FS	122.7			
			FS	255.4			
	178.28	(FSS) RT 40-08-00/122-18-00	E	121.5 /243.0			
			AS	123.6			
			FS	122.2			
			FS	122.7			
			FS	255.4			
			TO	109.8			
	154.35	LRCO (Chico)	RO	122.1			
			RO	123.65			
	175.68	LRCO (Redding)	TO	115.7			
			TO	108.4			
	203.62	LRCO (Redding)	RO	122.1			
			RO	123.65			
240.62	SFO (Fall River Mills)	FS	122.2				
		FS	122.7				
191.95	SFO (Quincy)	FS	122.7				
		FS	122.7				

Exhibit 10-4 (Cont.)

ZOA FSSs: FREQUENCY ASSIGNMENTS

NAME	D (miles)	LOCATION	FUNCTION	V/U	ATCT	I.L.S. LDA	DI
Reno	180.00	FSS 39-30-27/119-46-26	E	121.5 /243.0	X	X	
			RO	122.1			
			FS	122.2			
			FS	122.7			
	185.46 210.15	BVOR LRCO (Hazen)	FS	255.4			
			TO	117.9			
			TO	114.1			
			RO	122.1			
Sacramento (Executive)	72.2	FSS 38-31-05/121-30-15	E	121.5 /243.0	X	X	X
			FS	122.05			
			FS	122.2			
			FS	123.65			
	145.82	LRCO (Lake Tahoe)	FS	255.4			
			TO	113.2			
	66.56	LRCO	RO	122.1			
			TO	115.2			
Salinas	64.97	FSS 36-39-02/121-36-09	E	121.5 /243.0	X	X	
			AAS	119.4			
			FS	122.2			
			FS	122.6			
	95.42	LRCO (Big Sur)	FS	255.4			
			TO	114.0			
	64.12	LRCO	RO	122.1			
			TO	117.3			
Stockton	47.41	FSS 37-53-48/121-15-01	E	121.5 /243.0	X	X	
			RO	122.1			
			FS	122.2			
			FS	122.4			
	65.09 49.21 56.65	BVOR (Linden)	FS	123.65			
			FS	255.4			
		LRCO (Modesto)	TO	114.8			
			TO	116.0			
Tonopah	264.63	FSS 38-04-30/117-05-40	E	121.5 /243.0			X
			AS	123.6			
			FS	122.2			
			FS	122.6			
	267.51	LRCO	FS	255.4			
			TO	117.2			
	194.72	LRCO (Bishop)	RO	122.1			
			FS	122.6			
285.2	LRCO (Beatty)	TO	114.7				
		RO	122.1				
228.34	LRCO (Coaldale)	TO	117.7				
		RO	122.1				
223.45	LRCO (Mina)	TO	115.1				
		RO	122.1				

Exhibit 10-4 (Cont.)

ZOA FSSs: FREQUENCY ASSIGNMENTS

NAME	D (miles)	LOCATION	FUNCTION	V/U	ATCT	ILS LDA	DF
Ukiah	125.84	FSS 39-07-45/123-12-08	E	121.5 /243.0			
			AS	123.6			
			FS	122.2			
	123.38	LRCO	FS	122.6			
			FS	255.4			
			TO	112.3			
	78.59	LRCO (Santa Rosa)	RO	122.1			
			TO	109.4			
			RO	122.1			

BEST AVAILABLE COPY

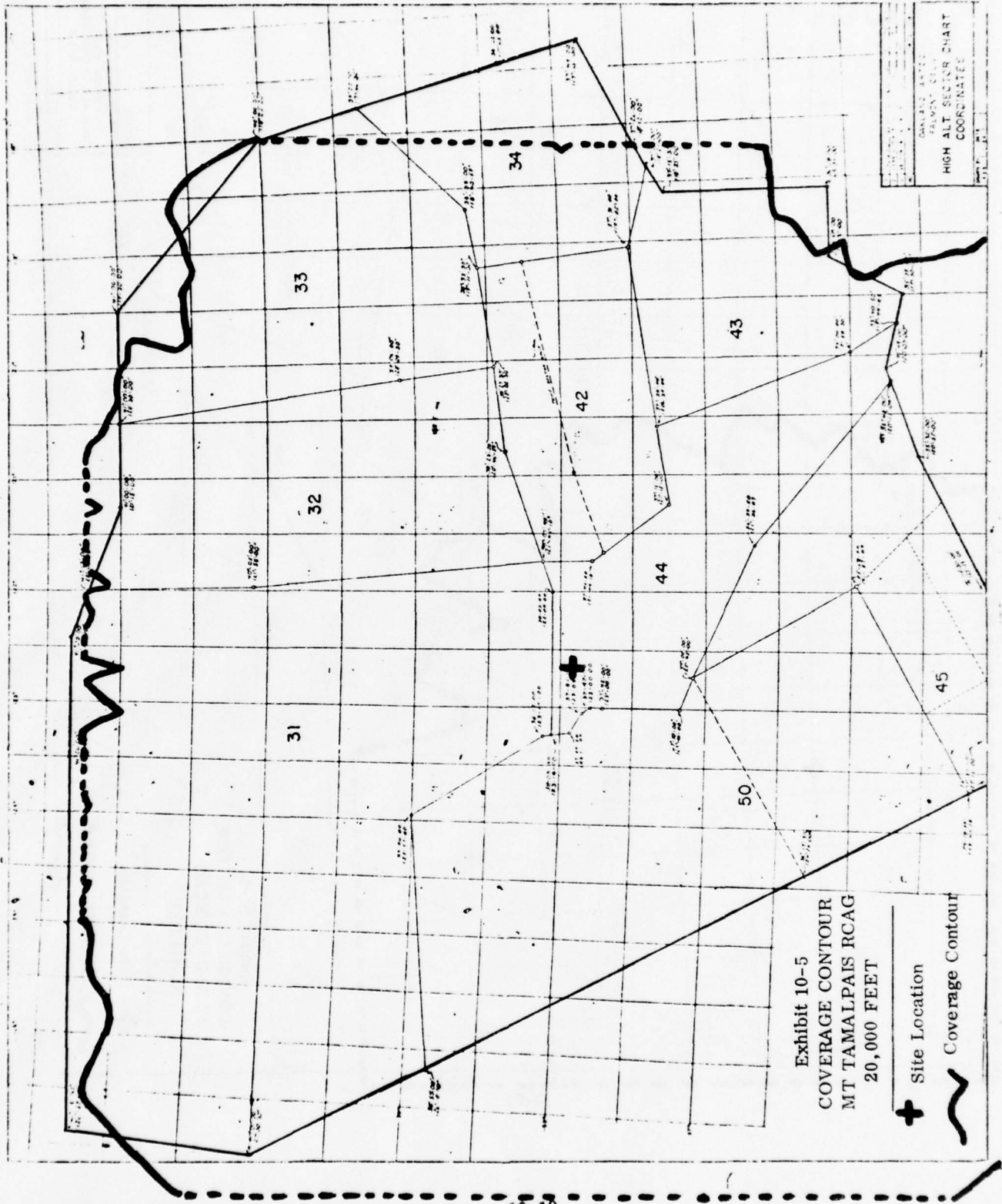

BEST AVAILABLE COPY

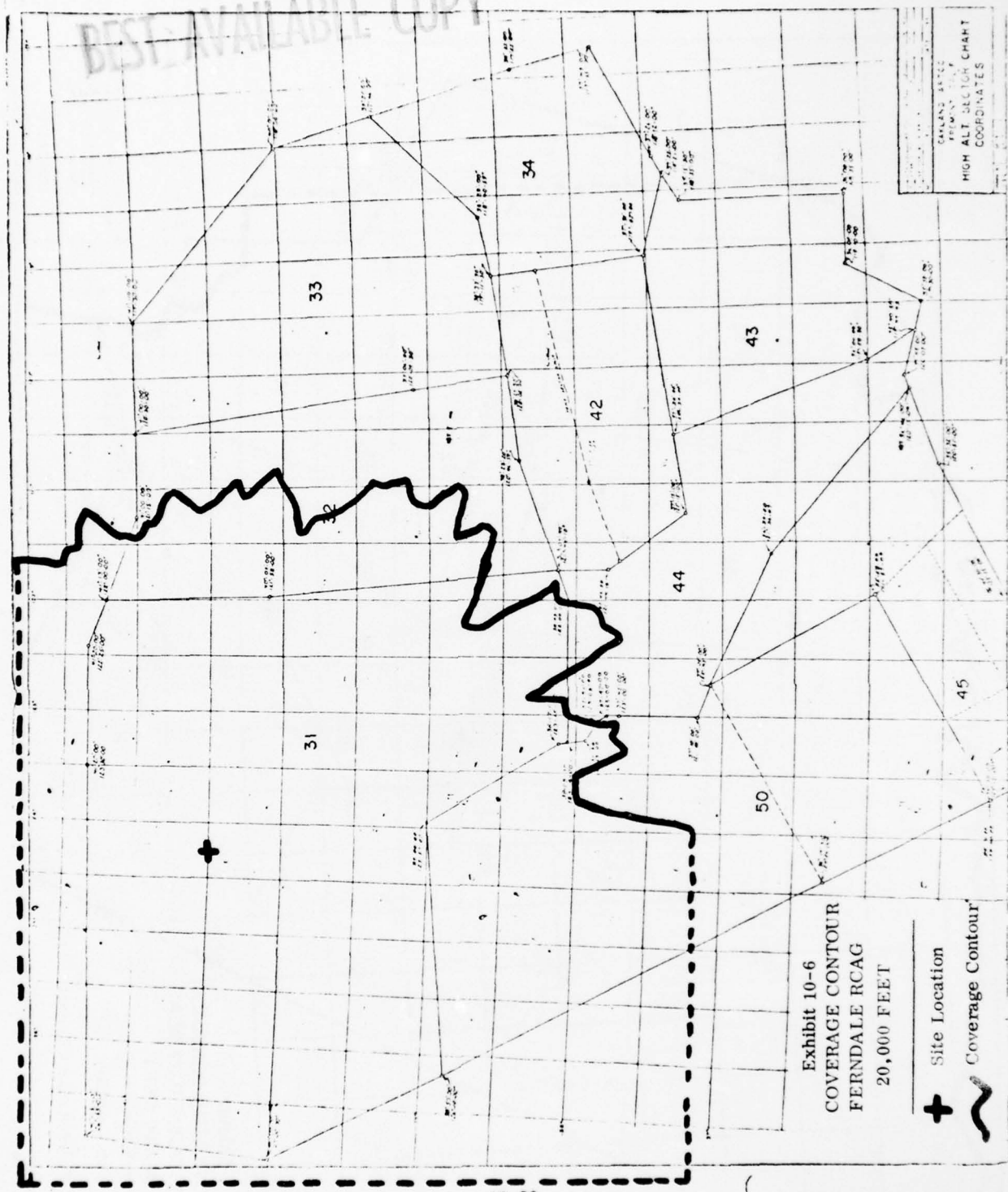
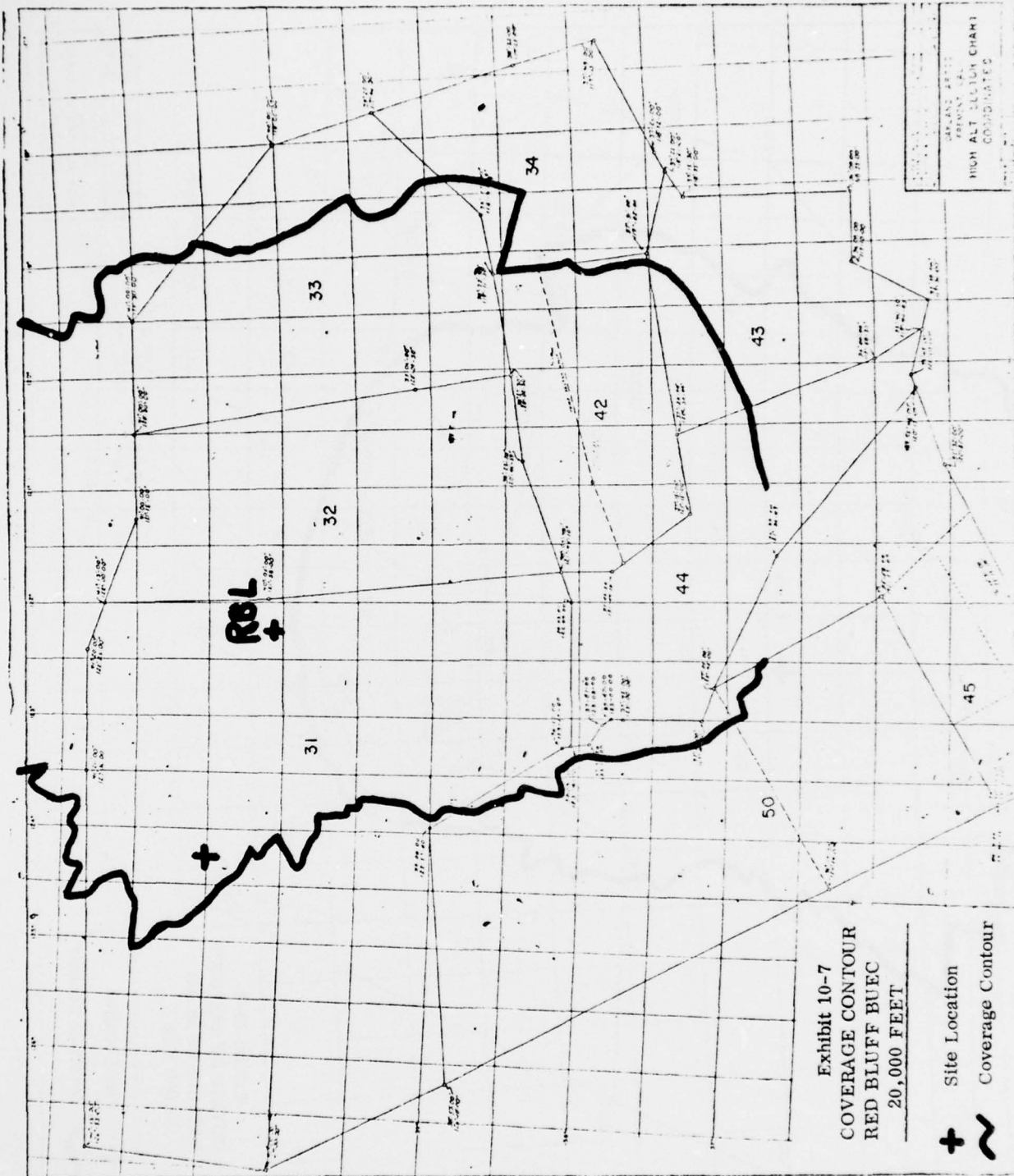

Exhibit 10-6
COVERAGE CONTOUR
FERNDALE RCAG
20,000 FEET

+ Site Location
~ Coverage Contour

CALCULATED
HIGH ALT SECTION CHART
COORDINATES



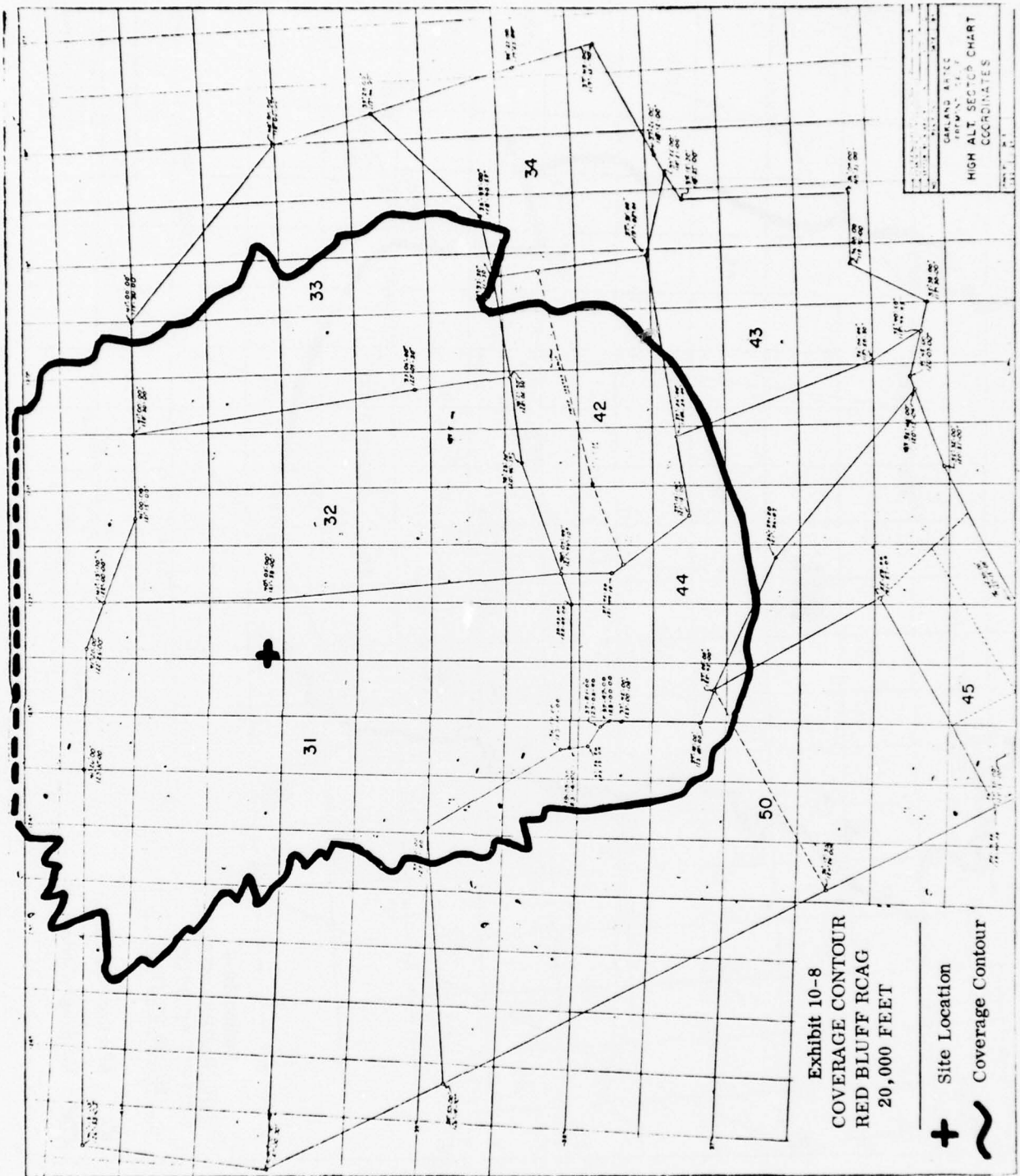
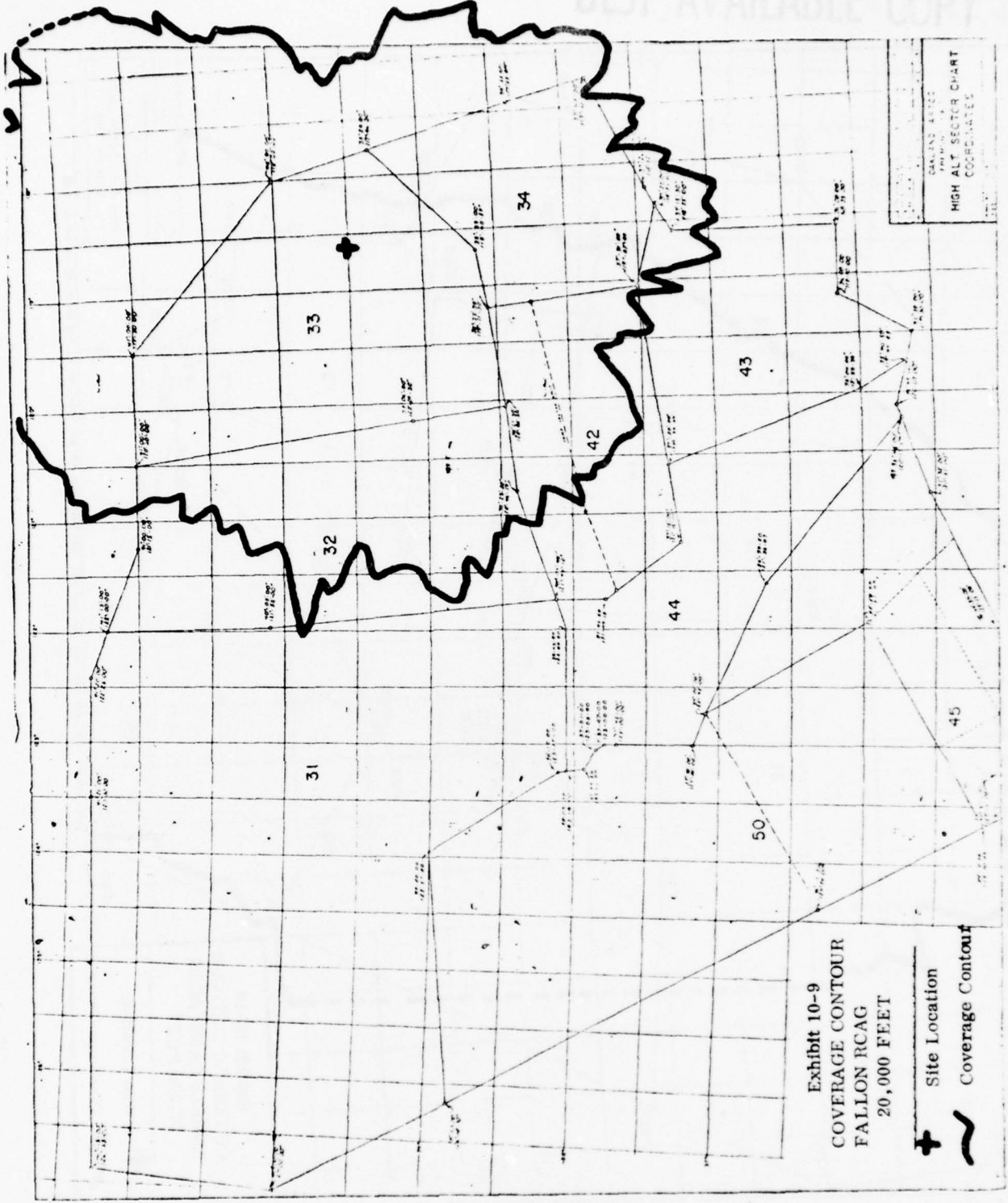

Exhibit 10-8
COVERED CONTOUR
RED BLUFF RCAG
20,000 FEET

+ Site Location
~ Coverage Contour

GRAND ARCS
HIGH ALT. SECTOR CHART
COORDINATES



BEST AVAILABLE COPY

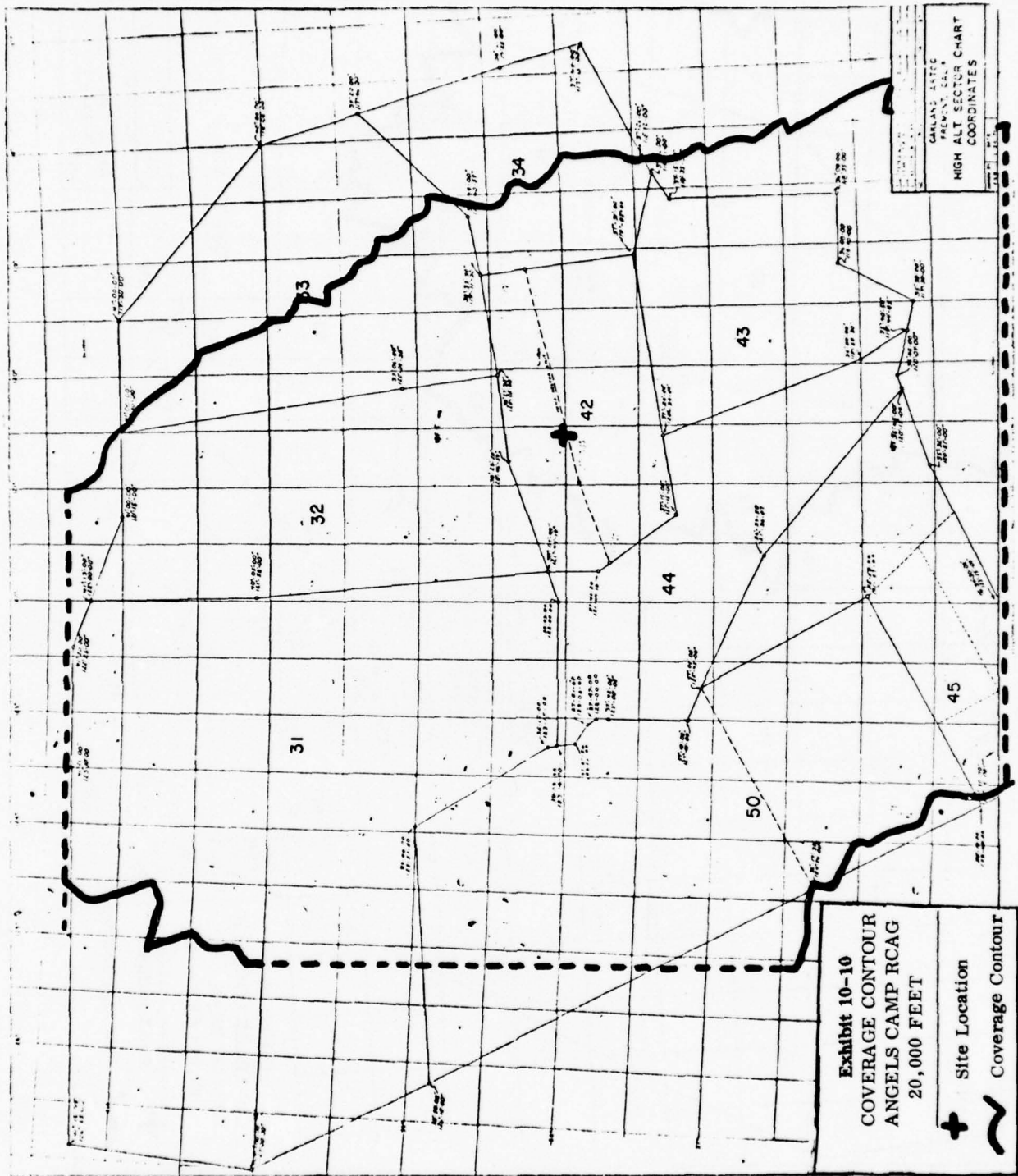

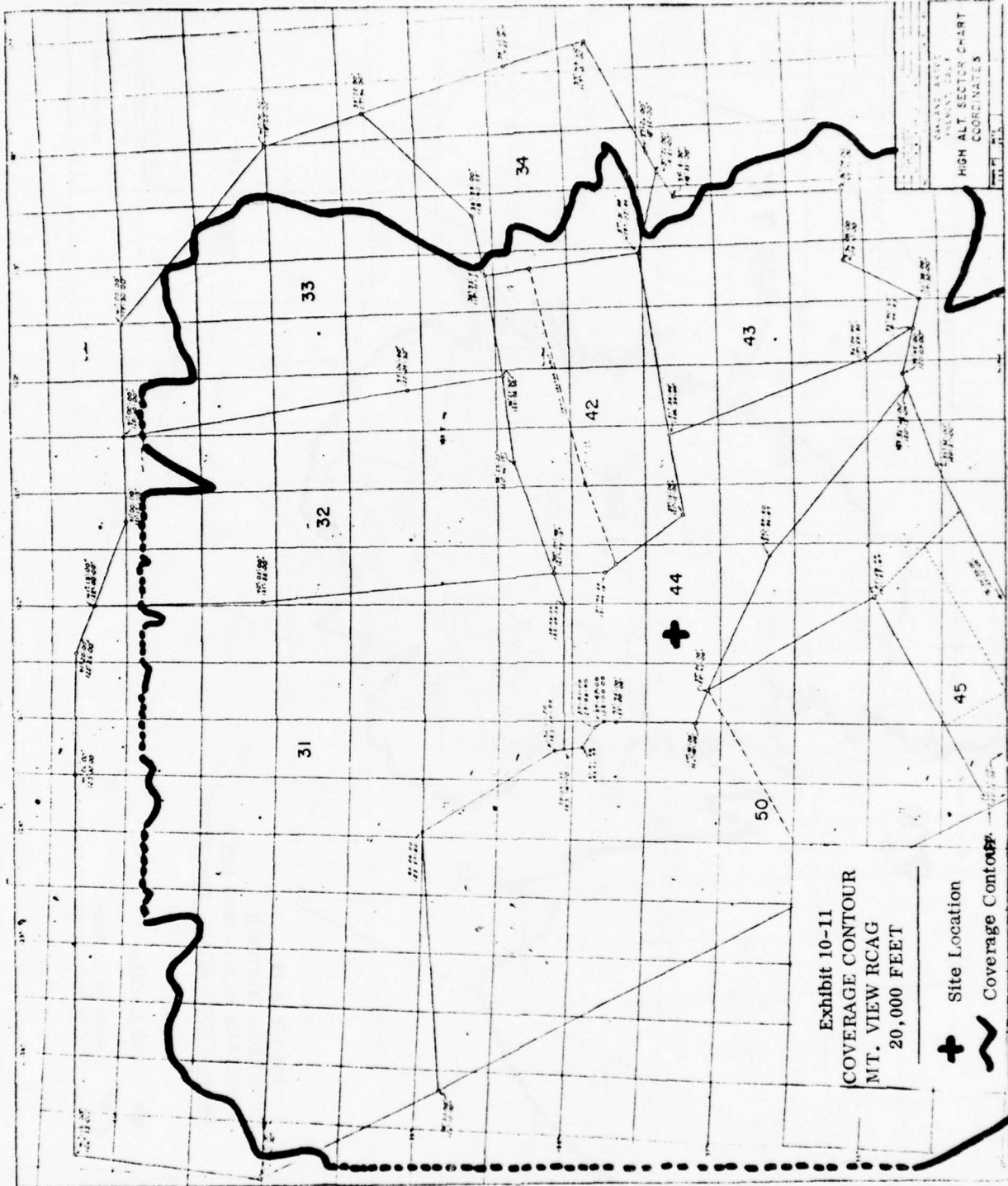

BEST AVAILABLE COPY

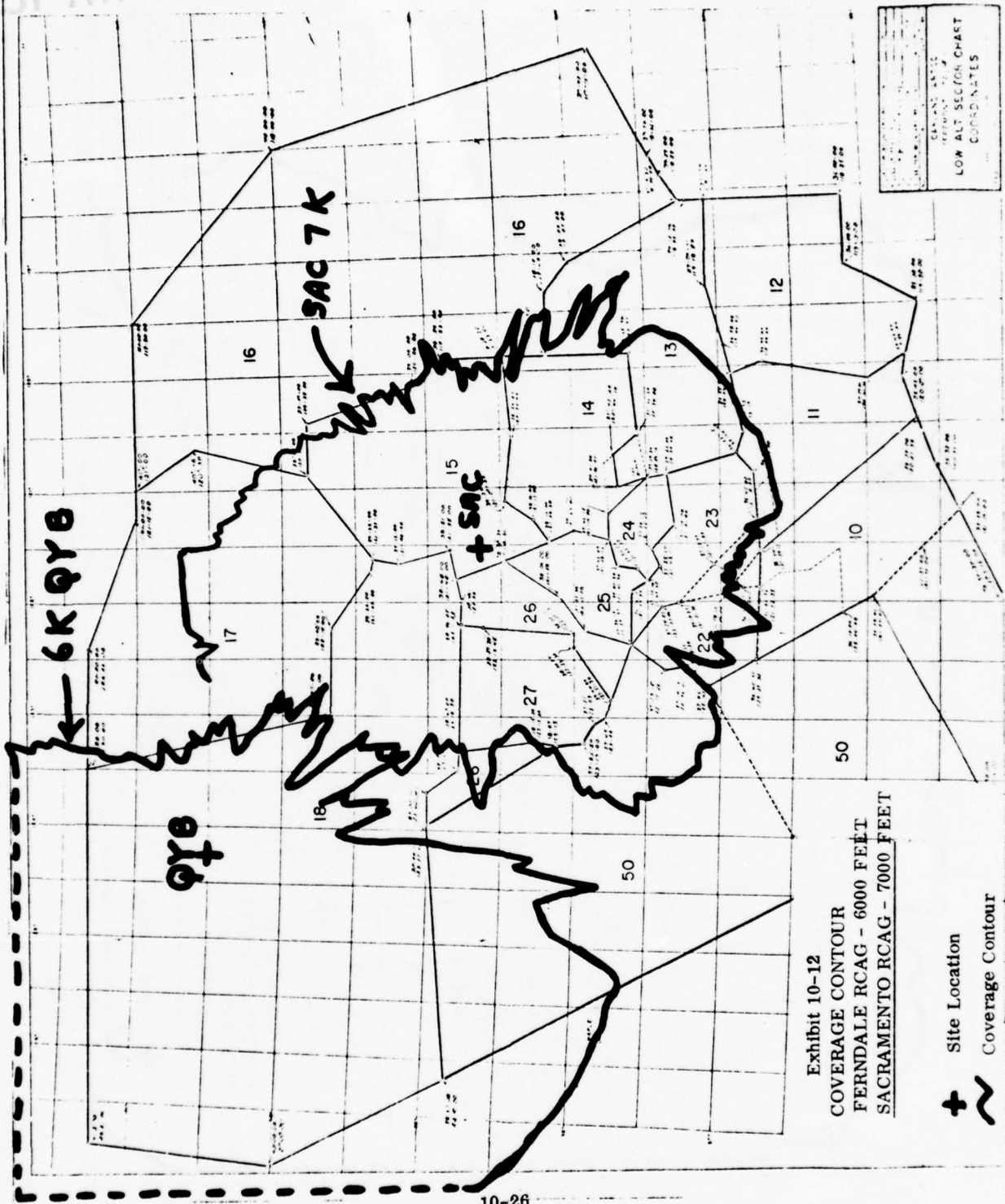

BEST AVAILABLE COPY

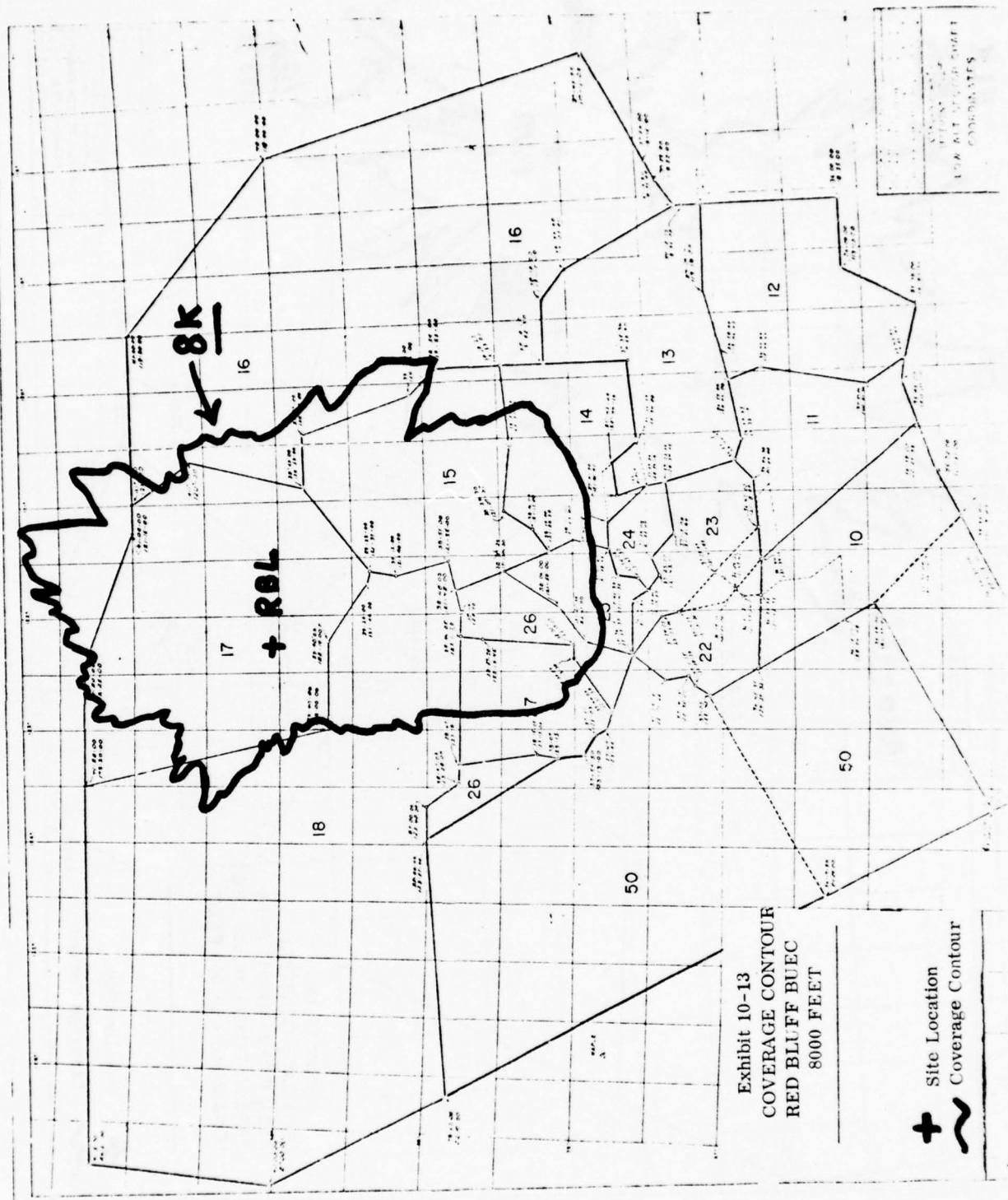

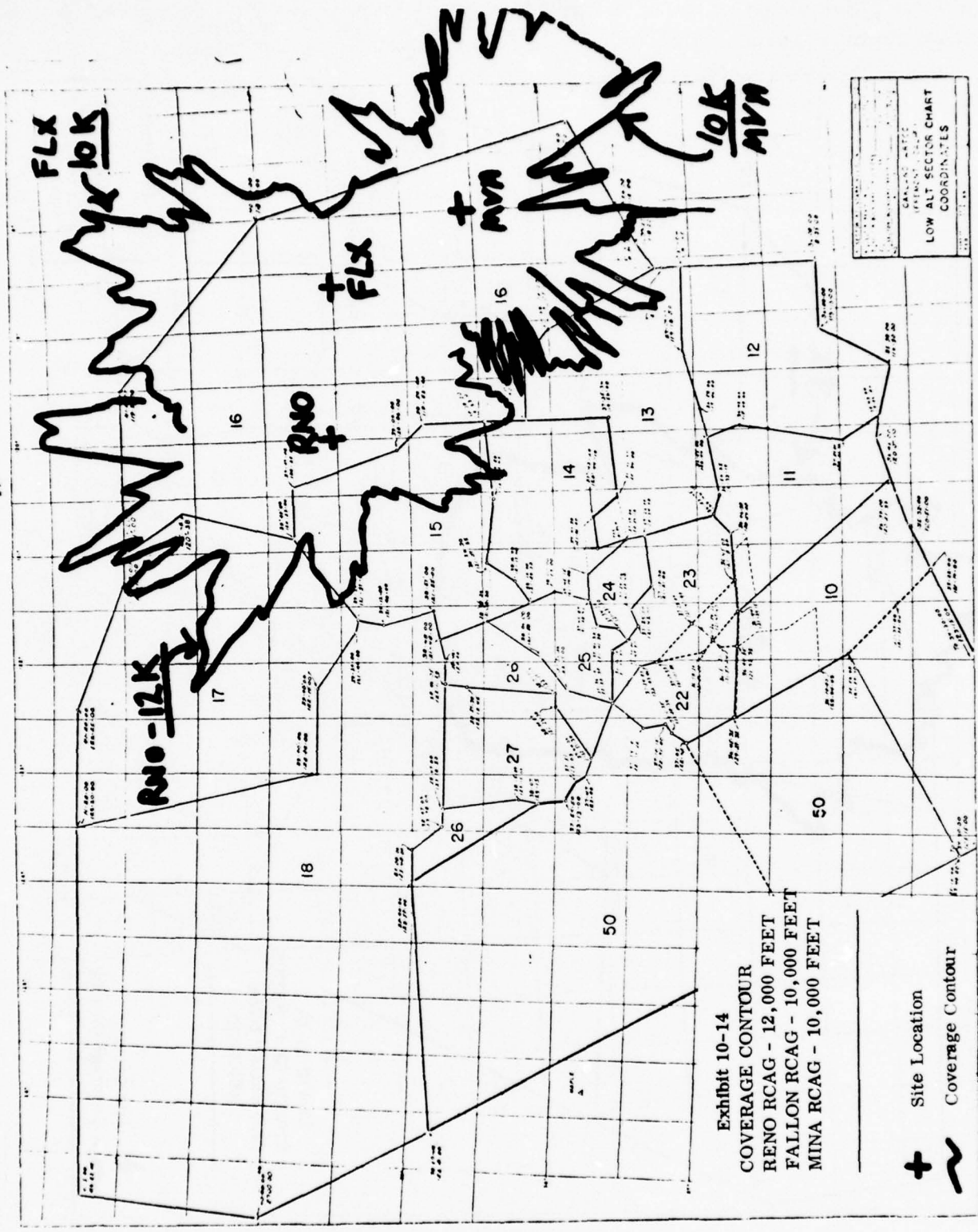

10-28

BEST AVAILABLE COPY

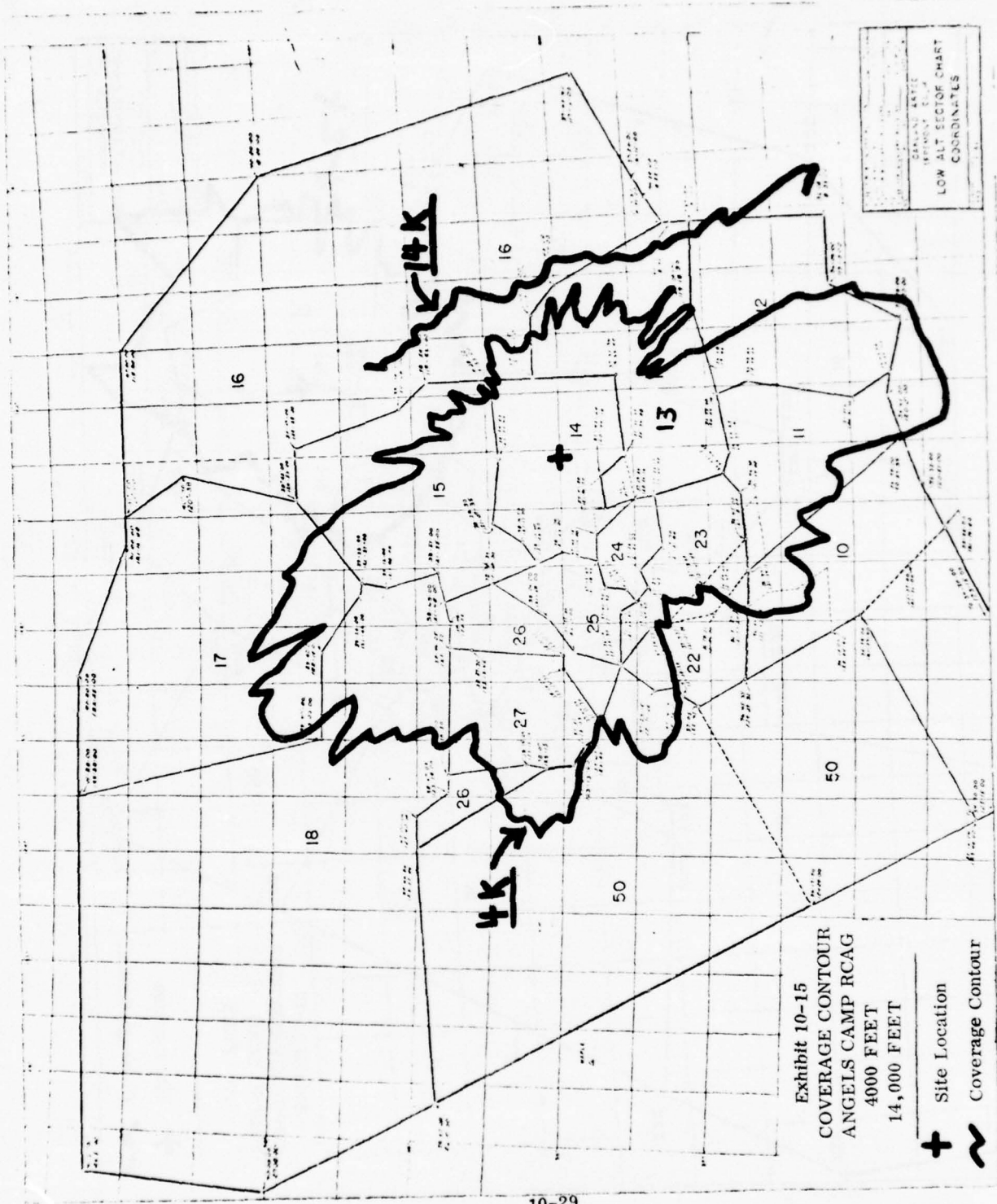
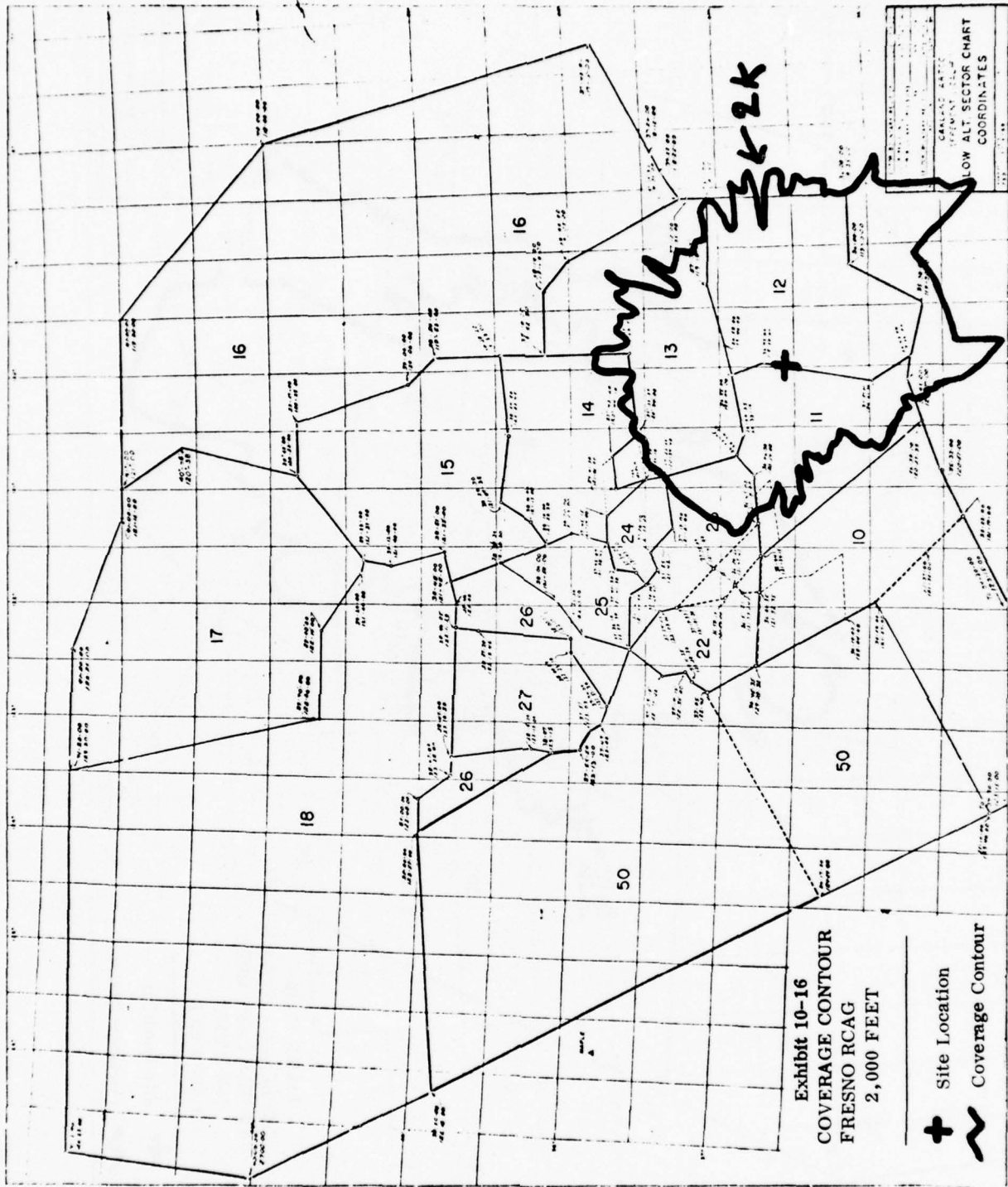

Exhibit 10-15
 COVERAGE CONTOUR
 ANGELS CAMP RCAG
 4000 FEET
 14,000 FEET
 + Site Location
 Coverage Contour

LOW ALT SECTOR CHART
 COORDINATES

10-29

BEST AVAILABLE COPY



BEST AVAILABLE COPY

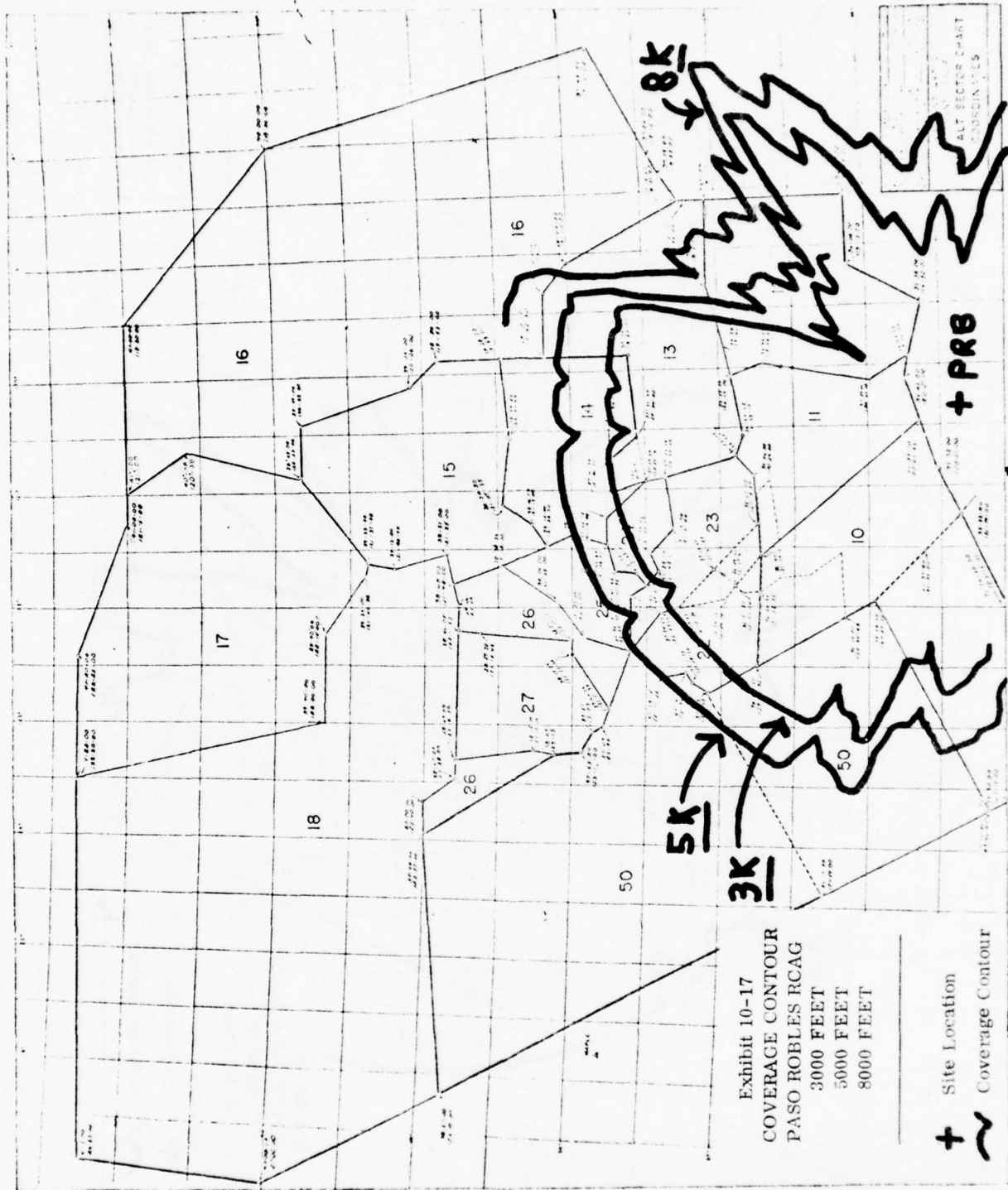
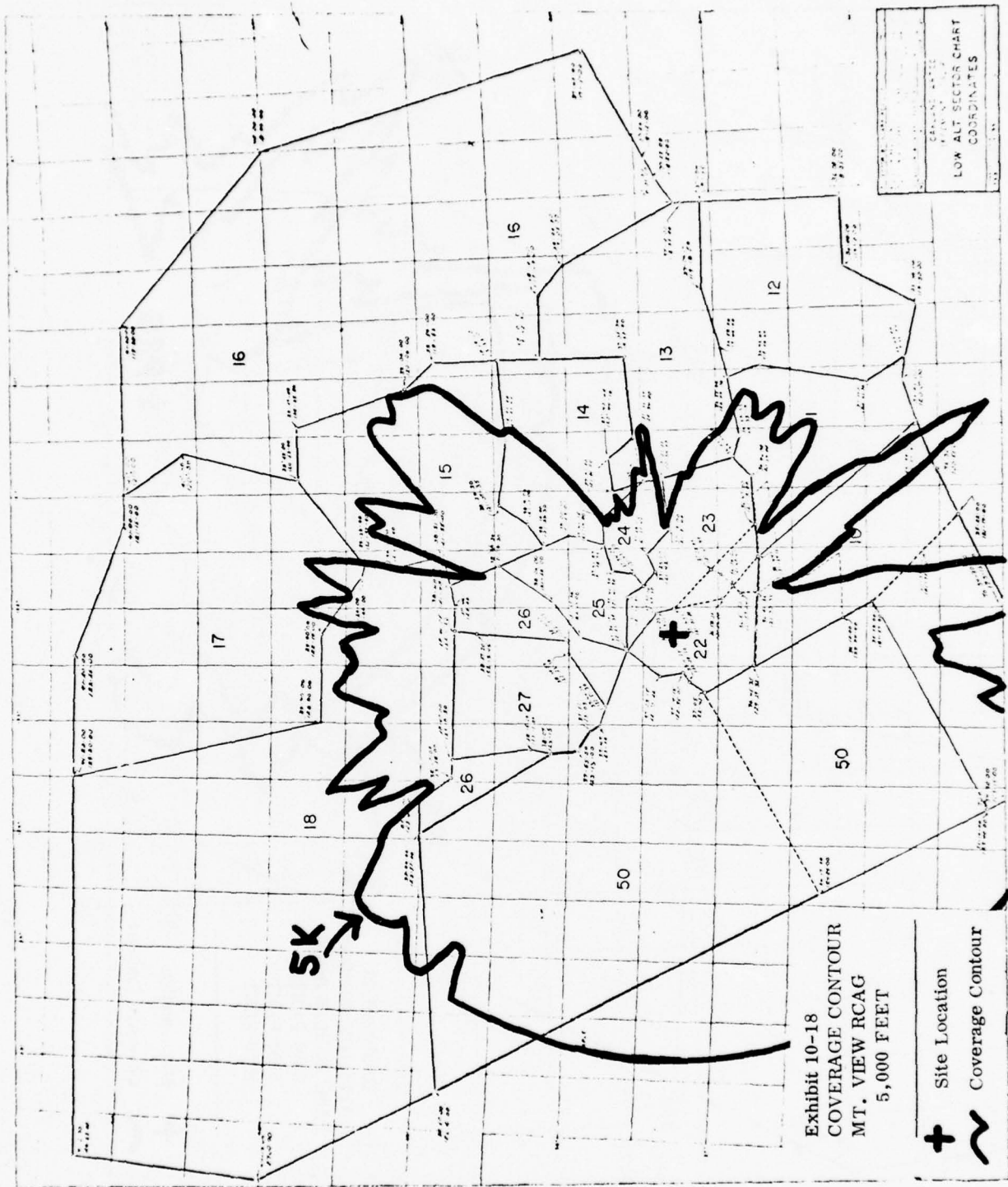

Exhibit 10-17
 COVERAGE CONTOUR
 PASO ROBLES RCAG
 3000 FEET
 5000 FEET
 8000 FEET

+ Site Location
 ~ Coverage Contour

UNAVAILABLE COPY



10-32

BEST AVAILABLE COPY

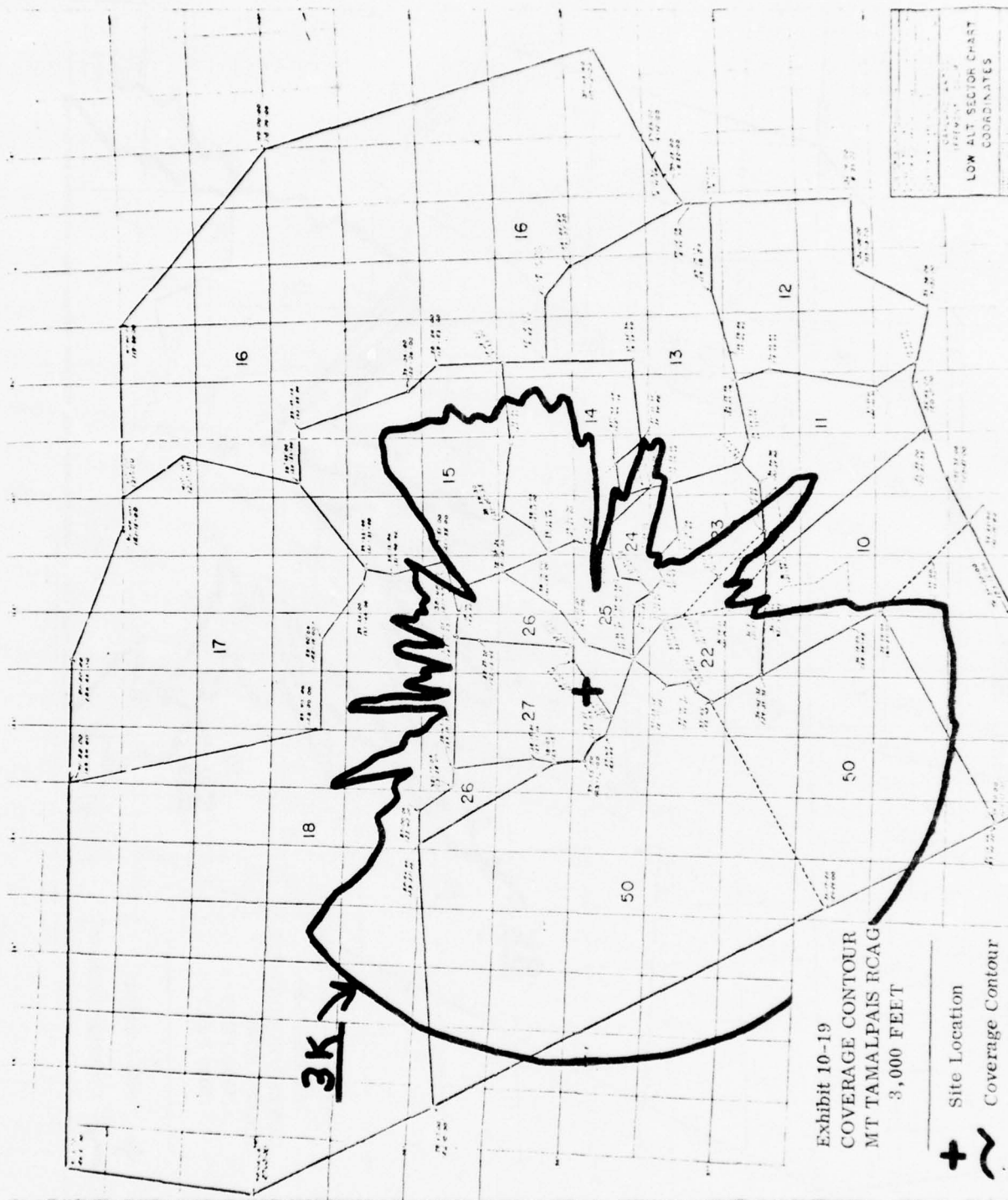

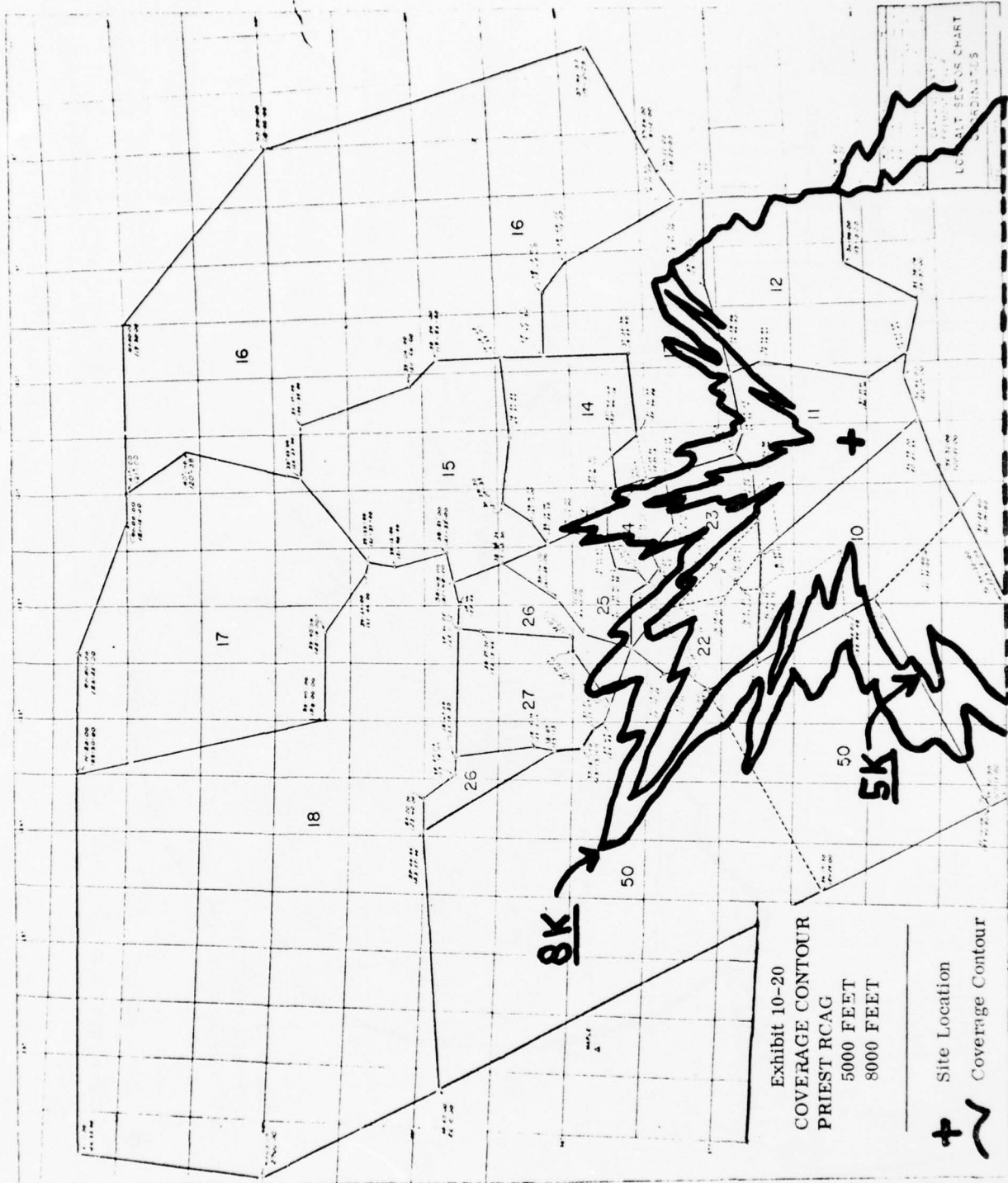

10-34

BEST AVAILABLE COPY

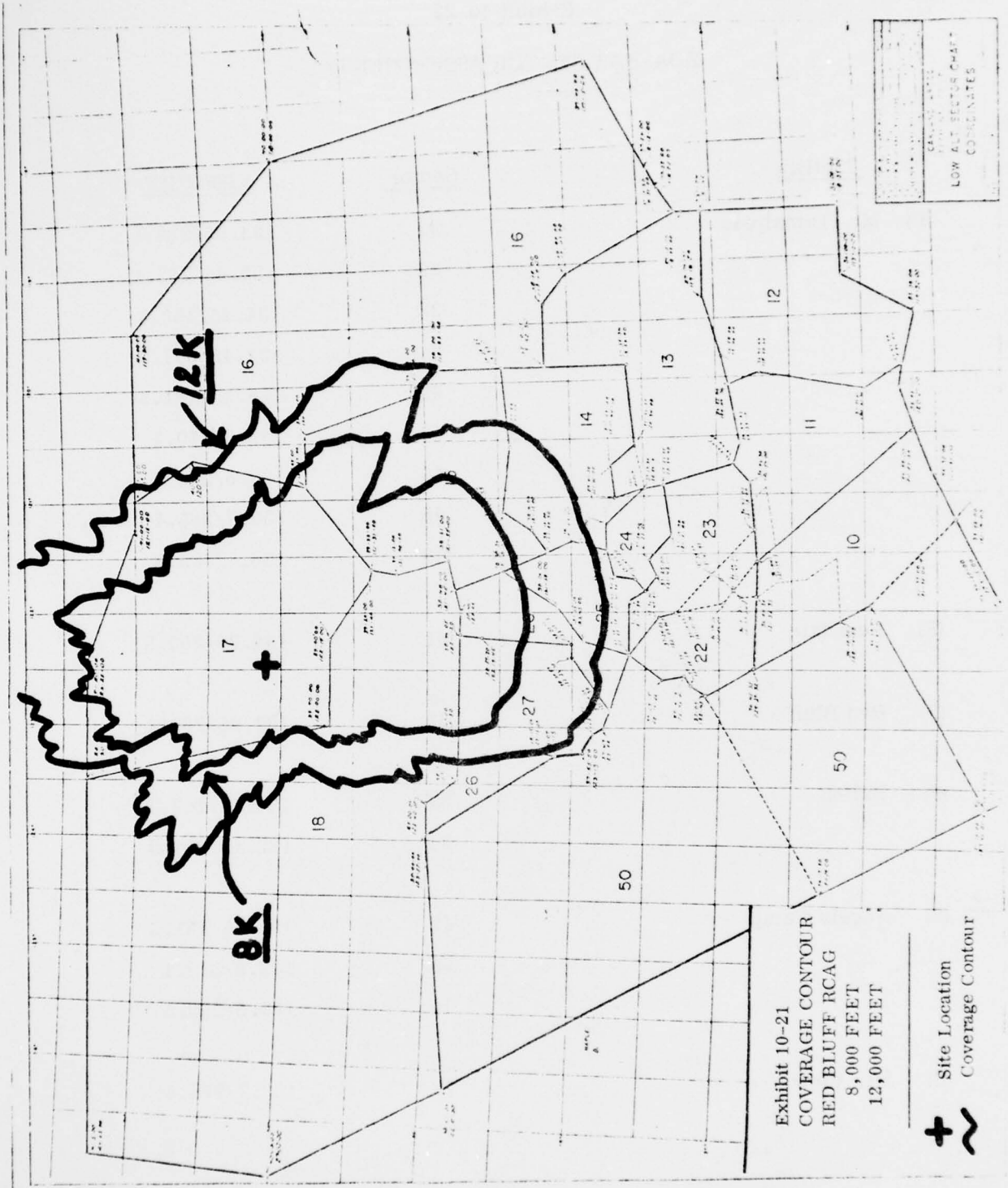

BEST AVAILABLE COPY

Exhibit 10-22

ZOA-HAT SECTOR ASSIGNMENTS

<u>Facility</u>	<u>Sector</u>	<u>VHF/UHF</u>
(P) Mt. Tamalpais	31	134.55/290.5
	32	132.95/269.1
	33	134.45/269.3
	34	132.45/307.3
	42	128.15/281.5
	43	132.8/319.1
	44	133.5/290.5
	45	133.7/285.4
(S) Ferndale	31	134.35/290.5
	32	132.95/269.1
(S) Red Bluff	33	134.45/269.3
	34	132.45/307.3
(S) Angels Camp	42	128.15/281.5
	43	132.8/319.1
	44	133.5/290.5
(S) Mt. View	45	133.7/285.4

Note: (P) = Primary; (S) = Secondary

Exhibit 10-23

ZOA - LAT SECTOR ASSIGNMENT

<u>Facility</u>	<u>Sector</u>	<u>VHF/UHF</u>
(P) Ferndale	18	123.9/284.7
(P) Sacramento	18	123.9/284.7
(P) Red Bluff (BUEC)	17	120.4/306.9
(P) Reno	16	128.8/285.5
(P) Fallon	16	128.8/285.5
(P) Mina	16	128.8/285.5
(P) Sacramento	15	120.6/307.8
(P) Angels Camp	14	133.3/319.9
(P) Angels Camp	13	120.2/290.4
(P) Fresno	12	123.8/353.8
(P) Paso Robles (BUEC)	11	126.9/343.8
(P) Paso Robles (BUEC)	10	128.7/307.0
(P) Mt. View	22	128.35/343.6
(P) Mt. View	23	135.0/317.5
(P) Mt. View	24	132.65/263.1
(P) Angels Camp	25	124.2/284.6
(P) Angels Camp	26	127.8/353.5
(P) Angels Camp	27	121.2/323.0
(P) Mt. Tamalpais	50	126.8/335.6

Exhibit 10-23 (Cont.)

ZOA - LAT SECTOR ASSIGNMENT

	<u>Facility</u>	<u>Sector</u>	<u>VHF/UHF</u>
(S)	Arcata (VOR)	18	123.9/284.7
(S)	Sacramento (RCO)*	18	123.9/284.7
(S)	Red Bluff (RTR)	18	123.9/284.7
(S)	Red Bluff (RTR)	17	120.4/306.9
(S)	Red Bluff (RTR)	16	128.8/285.5
(S)	Lovelock (VOR)	16	128.8/285.5
(S)	Tonopah (LRCO)	16	128.8/285.5
(S)	Sacramento (RCO)*	15	120.6/307.8
(S)	Stockton (VOR)	14	133.3/319.9
(S)	Stockton (VOR)	13	120.2/290.4
(S)	Fresno (VOX)	12	123.8/353.8
(S)	Paso Robles (VOR)	11	126.9/343.8
(S)	Paso Robles (VOR)	10	128.7/307.0
(S)	Mt. Tamalpais (RCAG)	22	128.35/343.6
(S)	Mt. Tamalpais (RCAG)	23	135.0/317.5
(S)	Mt. Tamalpais (RCAG)	24	132.65/263.1
(S)	Linden (VOR)	25	124.2/284.6
(S)	Linden (VOR)	26	127.8/353.5
(S)	Linden (VOR)	27	121.2/323.0
(S)	Mt. View (RCAG)	50	126.8/335.6

* Unmanned FSS.

Note: (P) - Primary; (S) - Secondary

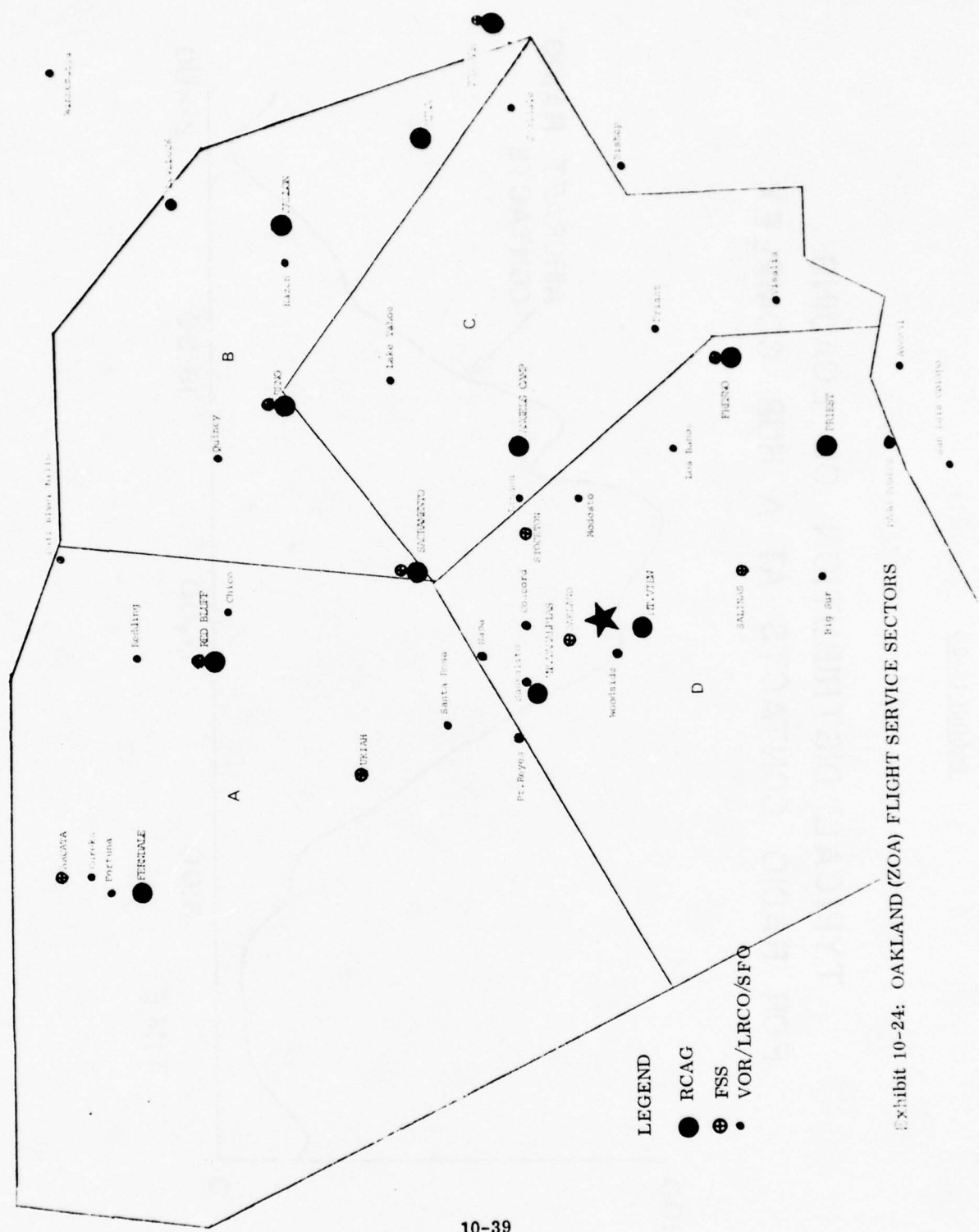

LEGEND
 ● RCAG
 ⊕ FSS
 • VOR/LRCS/SFO

Exhibit 10-24: OAKLAND (ZOA) FLIGHT SERVICE SECTORS

Exhibit 10-25

TYPICAL DISTRIBUTION OF LOADING
FOR RADIO CONTACTS AT A HUB COMPLEX



Exhibit 10-26

ZOA - FSS SECTOR ASSIGNMENT

SECTOR	FUNCTION	FREQUENCY
A	EFAS	122.0
	Emergency	121.5/243.0
	FSS	122.55/255.4
	FSS	122.75
B	EFAS	122.0
	Emergency	121.5/243
	FSS	122.4
C	EFAS	
	Emergency	121.5/243
	FSS	122.65/255.4
D	EFAS	122.0
	Emergency	121.5/243
	FSS	122.2/255.4
	FSS	122.3
	FSS	122.6

As indicated in Exhibit 10-23, the FSS frequencies have been divided among the four sectors rather than utilizing common sets as is current practice.

Exhibit 10-27

ZOA - ENROUTE ATC/FSS SECTOR ASSIGNMENTS

FACILITY	FUNCTION	SECTOR	VHF/UHF
Ferndale	LAT/ATC	18	123.9/284.7
	EFAS	A	122.0
	Emergency	A	121.5/243.0
	FSS	A	122.5/255.4
	FSS	A	122.75
Sacramento	LAT/ATC	18	123.9/284.7
	LAT/ATC	15	120.6/307.8
Red Bluff (BUEC)	LAT/ATC	17	120.4/306.9
	EFAS	A	122.0
	Emergency	A	121.5/243.0
	FSS	A	122.5/255.4
	FSS	A	122.75
	FSS	B	122.4
Reno	LAT/ATC	16	128.8/285.5
Fallon	LAT/ATC	16	128.8/285.5
	EFAS	B	122.0
	Emergency	B	121.5/243.0
	FSS	B	122.4
Mina	LAT/ATC	16	128.8/285.5
	EFAS	B	122.0
	Emergency	B	121.5/243.0
	FSS	B	122.4
	FSS	C	122.65/255.4

Exhibit 10-27 (continued)

ZOA - ENROUTE ATC/FSS SECTOR ASSIGNMENTS

FACILITY	FUNCTION	SECTOR	VHF/UHF
Angels Camp	LAT/ATC	14	133.3/319.9
	LAT/ATC	13	120.21/290.4
	LAT/ATC	25	124.2/284.6
	LAT/ATC	26	127.8/353.5
	LAT/ATC	27	121.2/323.0
	EFAS	C	122.0
	Emergency	C	121.5/243.0
	FSS	C	122.65/255.4
Fresno	LAT/ATC	12	123.8/353.8
	EFAS	C	122.0
	Emergency	C	121.5/243.0
	FSS	C	122.65/255.4
Paso Robles (BUEC)	LAT/ATC	11	126.9/343.8
	LAT/ATC	10	128.7/307.0
	EFAS	D	122.0
	Emergency	D	121.5/243.0
	FSS	D	122.2/255.4
	FSS	D	122.3
	FSS	D	122.6
	FSS	D	122.6
Mt. View	LAT/ATC	22	128.35/343.6
	LAT/ATC	23	135.0/317.5
	LAT/ATC	24	132.65/263.1
	EFAS	D	122.0
	Emergency	D	121.5/243.0
	FSS	D	122.2/255.4
	FSS	D	122.3
	FSS	D	122.6

Exhibit 10-27 (continued)

ZOA - ENROUTE ATC/FSS SECTOR ASSIGNMENTS

FACILITY	FUNCTION	SECTOR	VHF/UHF
Mt. Tamalpais	HAT/ATC	31	134.35/290.5
		32	132.95/269.1
		34	134.45/269.3
		34	132.45/307.3
		42	128.15/281.5
		43	132.8/319.1
		44	133.5/290.5
		45	133.7/285.4
		50	126.8/335.6
		50	126.8/335.6
	LAT/ATC	50	126.8/335.6
	EFAS	A	122.0
	Emergency	A	121.5/243.0
	FSS	A	122.5/255.4
FSS	A	122.3	

Exhibit 10-28

ANGELS CAMP REMOTE COMMUNICATIONS AIR
GROUND SITES COST DATA

Latitude	38° - 01' - 14"N	Site 1
Longitude	120° - 35' - 02"W	
Elevation	2898' MSL	(Sites 1 and 2)
Latitude	38° - 01' - 24"N	Site 2
Longitude	120° - 35' - 20"W	
* Access Rd MTCE - annually		260.00
* Eng/Gen Fuel - annually		400.00
* Real Estate = \$1000/1.4A - 1977 (renewal - 5 x = 5000)		5000.00
* Manpower GS-11/5 x 1.88/yr (PLT &ELEC)		34782.00
* Power		4915.00
* Leased Lines (9)		23356.00
	TOTAL	<u>68713.00</u>

* Sites 1 and 2

ANGELS CAMP 1

DESCRIPTION	QTY.	COST	
		Unit	Total
MT - 686 Rack	8	200.00	1600.00
Coax. Relay Panel	12	62.00	744.00
T - 282 UHF XMTR	8	935.00	7480.00
MD - 141 Modulator-Pwr.Sup.	8	462.00	3696.00
RV - 4 VHF RCVR	8	286.00	2288.00
R - 361 UHF RCVR	8	576.00	4608.00
TV - 6 VHF XMTR	8	1250.00	10000.00

Exhibit 10-28 (Cont.)

ANGELS CAMP REMOTE COMMUNICATIONS AIR

GROUND SITES COST DATA

ANGELS CAMP 1 (Cont.)

DESCRIPTION	QTY.	COST		
		Unit	Total	
CA - 1620/3	Relay Panel	5	521.00	2605.00
CA - 1621	Tone Cabinet RCV Term	4	1478.00	5912.00
CA - 1782	R.O. Amplifier	5	200.00	1000.00
CA - 1622	Pwr. Supply	5	114.00	570.00
	Std. Rack	8	282.00	2256.00
FA - 7845	UHF Discone	5	56.00	280.00
FA - 5675	VHF CP Ant.	2	61.00	122.00
FA - 5441A	VFH Coaxial	3	56.00	168.00
AS-505-GR	UHF Ant.	2	700.00	1400.00
AS-768-GR	UHF Ant.	1	700.00	700.00

ANGELS CAMP 2

DESCRIPTION	QTY.	COST		
		Unit	Total	
	Coax. Relay Panel	12	62.00	744.00
T - 282	UHF XMTR	8	935.00	7480.00
MD - 141	Modulator-Pwr.Supply	8	462.00	3696.00
RV - 4	VHF RCVR	8	286.00	2288.00
R-361	UHF RCVR	8	576.00	4608.00
TV - 6	VHF XMTR	8	1250.00	10000.00
CA - 1620/3	Relay Panel	4	521.00	2084.00
CA - 1621	Tone RCV Terminal	4	1478.00	5912.00

Exhibit 10-28 (Cont.)

ANGELS CAMP REMOTE COMMUNICATIONS AIR
GROUND SITES COST DATA

ANGELS CAMP 2 (Cont.)

DESCRIPTION	QTY.	COST		
		Unit	Total	
CA - 1782	R.O. Amplifier	4	200.00	800.00
CA - 1622	Power Supply	4	114.00	456.00
MT - 686	Rack	8	200.00	1600.00
	Std. Rack	8	282.00	2256.00
FA - 7845	UHF Discone	8	56.00	448.00
FA - 5675	VHF CP ANT	5	61.00	305.00
FA - 5441A	VHF Coaxial	4	56.00	224.00

ANGELS CAMP 1 AND 2

DESCRIPTION	QTY.	COST	
		Unit	Total
Batteries	8	300.00	2400.00
Load Bank	2	900.00	1800.00
Swtch Bkr. Panel	2	1500.00	3000.00
Dist. Panel	4	800.00	3200.00
Work Bench	4	60.00	240.00
Cabinets	6	85.00	510.00
Chem. Toilet	2	150.00	300.00
Test Eqmt. (1&2)		17600.00	17600.00
Air. Cond.	12 tons	3600.00	3600.00
Heating	2 tons	200.00	200.00
Ant Support	4	1125.00	4500.00
		TOTAL	125480.00

Exhibit 10-29

REMOTE COMMUNICATIONS AIR GROUND SITE
COST DATA SUMMARY

RECURRING COSTS	MT. TAMALPAIS	FRESNO	ANGELS CAMP	5 SITE AVERAGE
Access Rd MTCE	455	65	260	208
Eng/Gen Fuel	200	200	400	240
Real Estate	2,400	2,500	5,000	2,980
Man Power	21,739	27,634	34,782	16,831
Power	2,074	3,810	4,915	2,240
Lease Lines	9,229	22,856	23,356	11,088
TOTAL	36,097	57,065	68,713	32,375
Equipment Costs	93,487	118,992	125,480	67,592
Cost per Channel *	31,162	19,832	20,913	14,381
Cost per Channel **	42,243	20,741	31,489	18,895

* Equipment only

** Equipment + recurring costs

Exhibit 10-30
 FRESNO FLIGHT SERVICE STATION
 COST DATA

Facility = Level II
 Latitude 36° - 46' - 18"
 Longitude 119° - 43' - 18"
 Elevation 332 MSL

Eng/Gen Fuel - annually 100.00
 Manpower: GS-9/5 x 1.2/yr (PLT & ELEC) 18,700.00
 GS-11/5 x .16 m/yr (MTCE Remote Site) 3,000.00
 Manpower=17 OPRN PSNL=GS-10 (14,825) 252,000.00

Power - annually 3,600.00
 Leased Lines - annually 12,000.00

TOTAL 289,000.00

DESCRIPTION	QTY.	COST	
		Unit	Total
CA - 1318 Rec Level Mon	1	50.00	50.00
RV - 7 VHF RCVR	11	250.00	2750.00
CA - 1308 Meter Pnl	1	50.00	50.00
RV - 11 VHF RCVR	1	250.00	250.00
RIS SABH Monitor Rec	1	216.00	216.00
CA - 1632 R.O. Amp	3	200.00	600.00
FA - 5238 R.O. Amp	1	200.00	200.00
CA - 1538 Spkr Amp	4	50.00	200.00
FL - 1 Reject 1020 Filter	1	25.00	25.00
RUP Mute Relay	1	125.00	125.00
RUP VHF Tunable Rec.	1	500.00	500.00
CA - 1317 Interphone Pnl	1	50.00	50.00
RCP HF Tunable RCVR	1	300.00	300.00
CA - 1718 UHF/VHF SW Pnl	2	98.00	196.00
CA - 1715 AUX 48 VDC PS	1	114.00	114.00

Exhibit 10-30 (continued)
 FRESNO FLIGHT SERVICE STATION
 COST DATA

	DESCRIPTION	QTY.	COST	
			Unit	Total
	Intercom	1	150.00	150.00
BC - 638A	Audio Dsc	1	300.00	300.00
CA - 1714	Xmtr Rly Pnl	2	62.00	124.00
CA - 1714	Pwr Sup	2	114.00	228.00
CA - 1666	Pwr Sup	3	114.00	342.00
	30KW Load	1	900.00	900.00
	Terminal Rack	1	286.00	286.00
FA - 6308	Tacan Mon Amp	2	1500.00	3000.00
CA - 1663	VF Signaling	1	1478.00	1478.00
	Line Mon Bridge Pnl	3	10.00	30.00
FA - 5250	V/F Signaling	2	1478.00	2956.00
CA - 1764	VOR Mon Amp	1	281.00	281.00
CA - 1311	Monophone Pnl	1	50.00	50.00
	VHF RX Mon B/U	1	50.00	50.00
R - 361/GR	UHF RCVR	2	576.00	1152.00
	Variable DC P.S.	1	150.00	150.00
CA - 2984	Trans Pnl	1	62.00	62.00
	RF Body Pnl	2	62.00	124.00
T-282/GR	UHF Xmtr	1	935.00	935.00
MD-141/GR	MOD Pwr Sup	1	462.00	462.00
TUQ	VHF XMTR	1	1000.00	1000.00
	Eng/Gen	1	6000.00	6000.00
	Racks	18	282.00	5076.00
	Test Eqmt/Tools	1	11629.00	11629.00
	Cabinets	3	85.00	255.00
	Work Bench	2	60.00	120.00
	SW Brkr Pnl	1	1500.00	1500.00
	Eng/Gen Battery	2	300.00	600.00
FA - 5217	Dial Mon Pnl	1	50.00	50.00
	WX Instrmt Pnl	1	1000.00	1000.00
CA - 1787	Nav aids XFR SW	1	100.00	100.00
FA - 5213	Squelch on/off Pnl	5	50.00	250.00

Exhibit 10-30 (continued)

FRESNO FLIGHT SERVICE STATION

COST DATA

DESCRIPTION	QTY.	COST		
		Unit	Total	
CA - 1502	Xmtr Cont Pnl	4	82.00	328.00
CA - 1521	Xmtr Cont Pnl	2	97.00	194.00
CA - 16666	Xmtr Cont Pnl	2	97.00	194.00
CA - 1790	Rec Cont Spkr Mute	7	150.00	1050.00
FA - 5211	Xmtr Ch Sel Pnl	1	97.00	97.00
FA - 5116/A	Vortac Mon Pnl	1	1000.00	1000.00
FA - 6420	Tacan Monitor	1	1500.00	1500.00
	4 Ch Adaptor Pnl	2	30.00	60.00
	Rup Sel Muting	1	125.00	125.00
	WX Guard Spkr Cont	1	50.00	50.00
FA - 5141	6 Ch Level Key Cont	2	52.50	105.00
FA - 5210	TWEB Equpt & Cont	1	16000.00	16000.00
FA - 5237	Jack - Box	2	43.00	86.00
FA - 5530	VHF/UHF DF	1	15000.00	15000.00
	Time Stamp	2	168.00	336.00
	Microphone EV-602D	2	25.00	50.00
	Mike W/608A	1	15.00	15.00
	Spkr AP10	2	25.00	50.00
	Telco Spkr/Amp	1	50.00	50.00
	Clock	1	400.00	400.00
FA - 5221	Console	3	500.00	1500.00
FA - 5222	Console	1	500.00	500.00
CA - 1450	Whip Ant LFR Mon	4	60.00	240.00
AT - 197	UHF XMT Ant	1	56.00	56.00
AT - 197	UHF Rec Ant	1	56.00	56.00
CA - 1350	TUQ VHF Stby Ant	1	60.00	60.00
CA - 1591	VHF RCV Ant	1	60.00	60.00
CA - 1594	VHF Coax Ant	1	60.00	60.00
	Whip-WX/B-Mon	1	50.00	50.00
	Spare Ants	8	56.00	448.00
CA - 1791	Rec Mix Pnl XFMR	7	50.00	350.00
CA - 1504	Foot Switch	3	130.00	390.00

Exhibit 10-30 (continued)

FRESNO FLIGHT SERVICE STATION

COST DATA

DESCRIPTION	QTY.	COST	
		Unit	Total
TTY (RO)	3	2000.00	6000.00
TTY (ASR)	1	4000.00	4000.00
TTY TD	1	200.00	200.00
TTY SW RACK	1	1500.00	1500.00
Hybrids	4	200.00	800.00
VHF Ant	4	60.00	240.00
		TOTAL	99466.00

Note: Above complement of equipment includes remote sites.

AVAILABILITY/RELIABILITY/MAINTAINABILITY

11.1 INTRODUCTION

The FAA Air/Ground Radio System serves a primary function in support of air traffic control operations and flight service operations. The loss of radio communications is equivalent to loss of the ground-based control operation, and therefore represents a serious degradation of safety.

The FAA requires continuous air/ground communications service, expressed as an availability of 0.9999; or approximately a one-hour outage per year for each air/ground channel.

The achievement of continuous availability depends upon a complex arrangement of equipments, switches, and telephone circuits that are maintained by FAA and telephone company personnel. The FAA employs a redundant, repairable system as a means of attaining the required service. Elements of the system are provided in a parallel-standby configuration, so that failure of an element can be overcome by switching in a backup and repairing the failed element.

The air/ground channel consists of five major elements that connect in series; as shown in Exhibit 11-1, failure of any major element results in a channel failure and loss of communications between ground-based control.

The FAA operation is complicated by a dependence upon leased circuit utilization for remoting communications and control, and by the necessity of interfacing with aircraft radio equipments. Both of these conditions tend to degrade FAA Air/Ground System performance, since the FAA does not have direct control of the circuits and aircraft radio equipments.

Exhibit 11-1: PRIMARY FAULT TREE FOR A/G RADIO (NO REDUNDANCY)

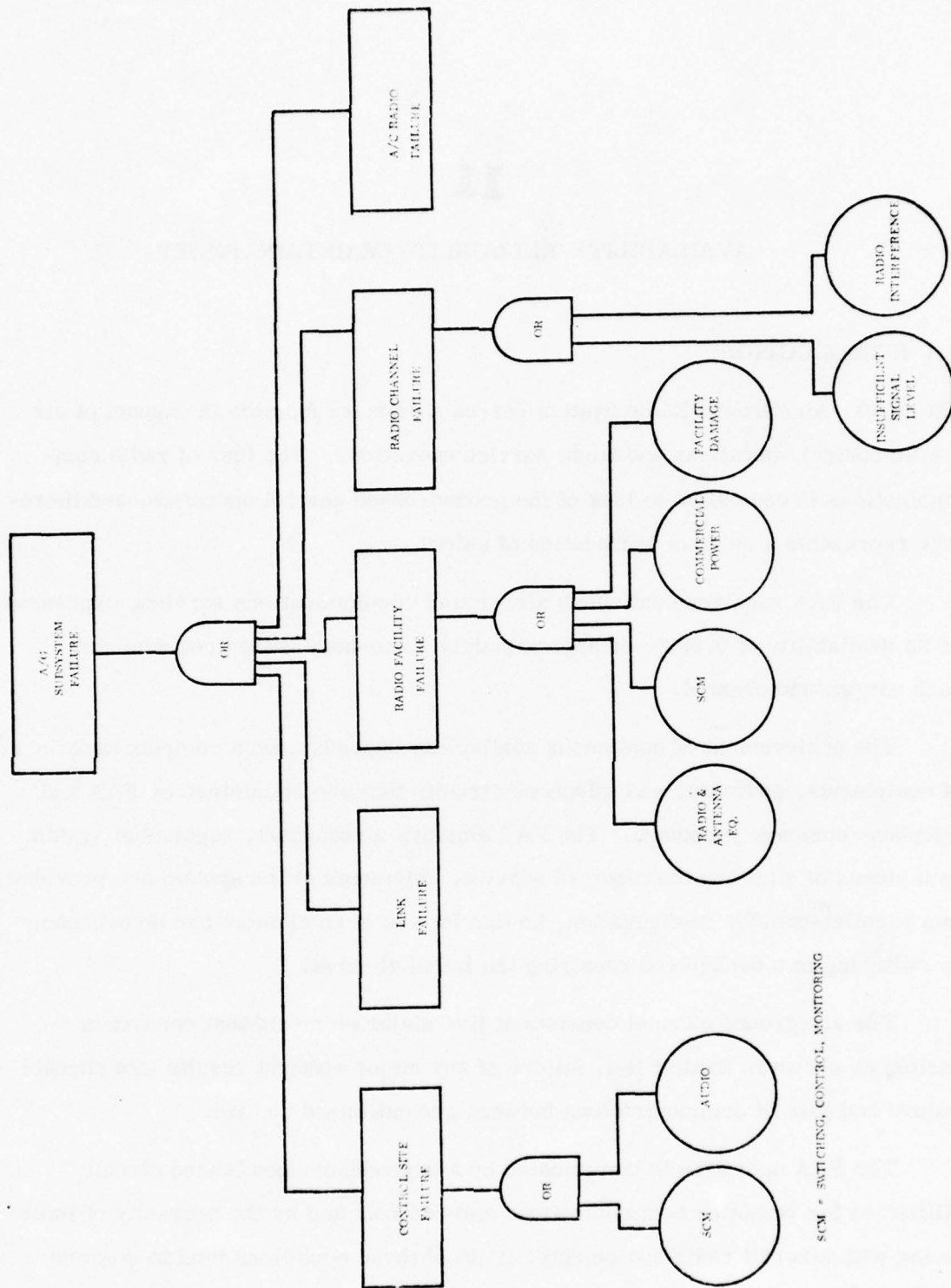

11-2

SCM = SWITCHING, CONTROL, MONITORING

The joint operational responsibilities make channel failures difficult to isolate among the five elements shown in Exhibit 11-1. The successful performance of air/ground radio depends upon the reliability of the various subsystems used and the maintenance policy employed for subsystem repair. The strategy of system design involves developing relationships among system availability, reliability, and maintainability. There are a number of alternatives for providing air/ground service operations and maintenance.

The primary air/ground radio requirement is line-of-sight radio coverage to all volumes of controlled air space. Within this basic constraint, there are various methods of configuring sites and equipments, and of remoting communications; analysis in this report defines the relationships involved and considers the alternative trade-offs.

11.2 AIR/GROUND RADIO SERVICE RELIABILITY

Exhibit 11-2 shows three radio system configurations representing different arrangements of the five series elements.

Configuration A is a simple series arrangement with no redundant elements. The system reliability (assuming each element has an equal reliability, r) is

$$R = r^5$$

Configuration B is an arrangement of two parallel systems similar to the RCAG-BUEC facilities as currently established. The system reliability is

$$R = 2r^5 - r^{10}$$

Configuration C is similar to a single RCAG arrangement with parallel redundant elements as shown. (Actually, only one radio channel is available in this configuration, for current RCAGs.) The system reliability is

$$R = (2r - r^2)^5$$

The table in Exhibit 11-2 shows the corresponding System Reliabilities of Configurations A, B, and C for two sample values of r .

Exhibit 11-2: RELIABILITY FOR REDUNDANT SYSTEMS

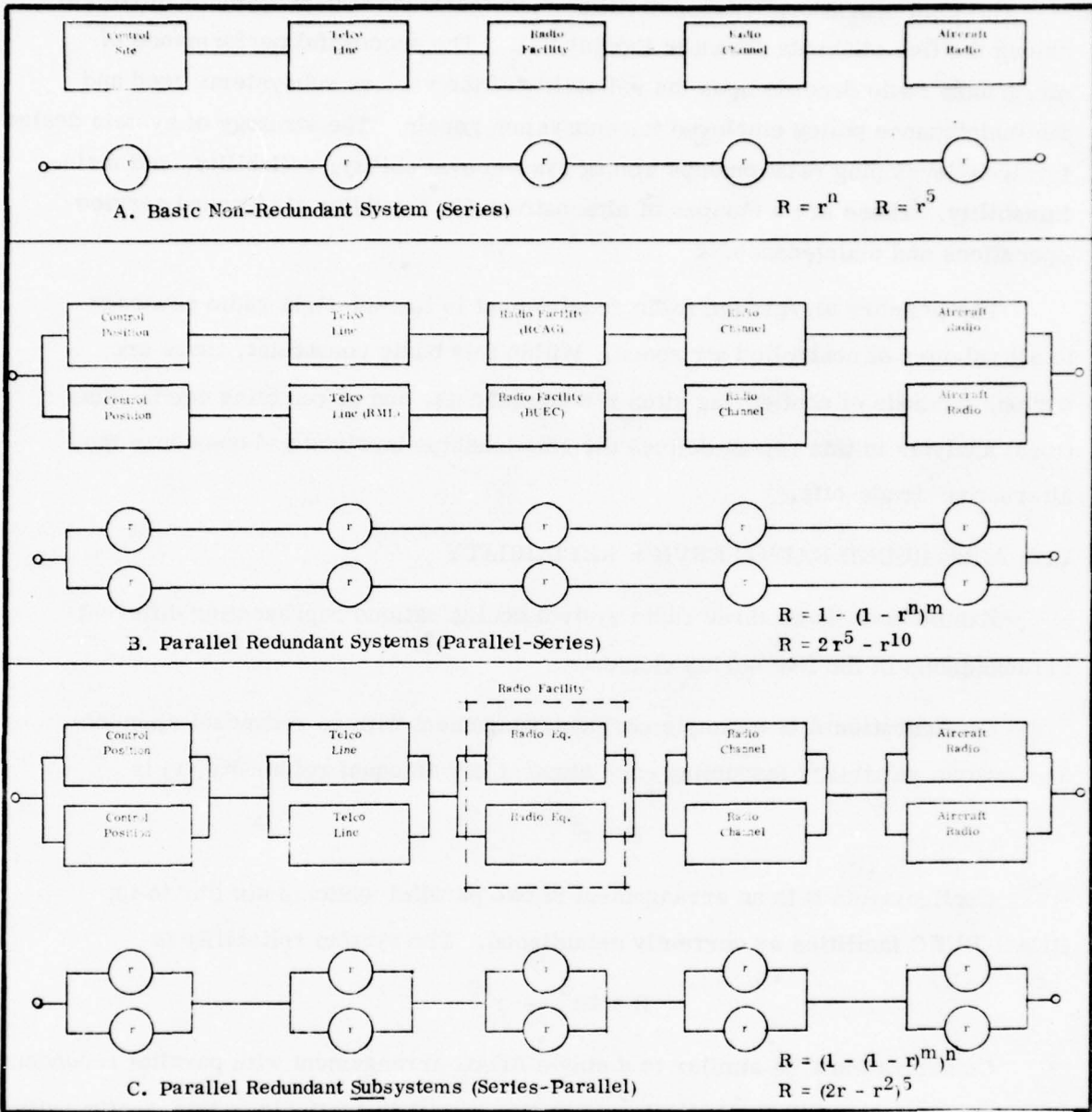

RELIABILITY FOR CONFIGURATIONS A; B; C		
Value of r	0.80	0.90
R(A)	0.33	0.59
R(B)	0.55	0.82
R(C)	0.81	0.94

Configuration C shows the highest reliability. This is because C contains more alternate paths around failed elements. In general, higher levels of redundancy (i. e., more system subdivisions with parallel elements) will result in increased reliability. The results indicate that it is most effective to utilize a single site with parallel redundant elements connected in series. If the required System Service Reliability can be achieved by a configuration similar to C, then it is not necessary or cost-effective to utilize a second facility (i. e., site). This must be qualified by consideration of catastrophic failures of either the facility (physical damage) or the telephone cable (cut or otherwise disrupted). For these infrequent occurrences (no available statistics), it is feasible, as discussed in Chapter 10 of this report, to utilize other facilities that possess the required overlap radio coverage. The concept of using the BUEC tunable transceiver as a backup communications equipment, but locating it within the primary single facility (e. g., the RCAG), appears to be an effective approach. This is also advantageous, since, as will be shown in section 11.6 of this report, a one-to-one backup of radio equipment is excessive. Therefore, k tunable transceivers (with $K < n$) backing up n primary radios represents a feasible system configuration. The tunable transceivers can also be made available to provide alternate site backup (in the event of catastrophic failure) to adjacent radio facilities. This approach follows the rationale of close packing radio equipments to provide maximum utility.

11.3 AIR/GROUND SERVICE RELIABILITY WITH SWITCHING

With perfect switching, it is advantageous to maximize the number of parallel redundant elements connected in series. For practical systems it is necessary to insert: 1) monitoring sensors for the detection of faults, and 2) system switches that will operate to maintain system continuity. Monitoring and switching devices operate with finite reliabilities that affect overall system reliability. Systems B and C of Exhibit 11-2 are reconfigured in Exhibit 11-3 to include monitoring devices with reliability $r(m)$ and switching devices with reliability $r(s)$. If the example of 11-2 is repeated for the simple case of $r(m) = r(s) = 0.9$, it is seen that the reliability of both configurations B and C deteriorates considerably. In

Exhibit 11-3

RELIABILITY WITH MONITORING AND SWITCHING

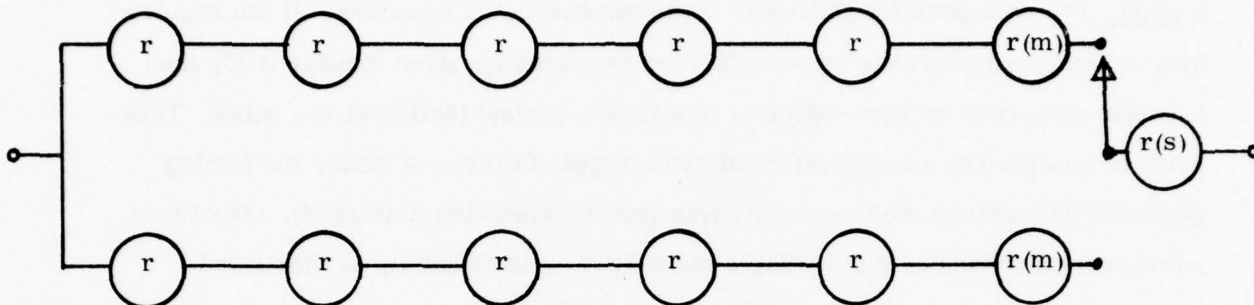

$$R = \{2r^5r(m) - r^{10}r(m)\}r(s)$$

B. Parallel Redundant Systems With Monitoring And Switching

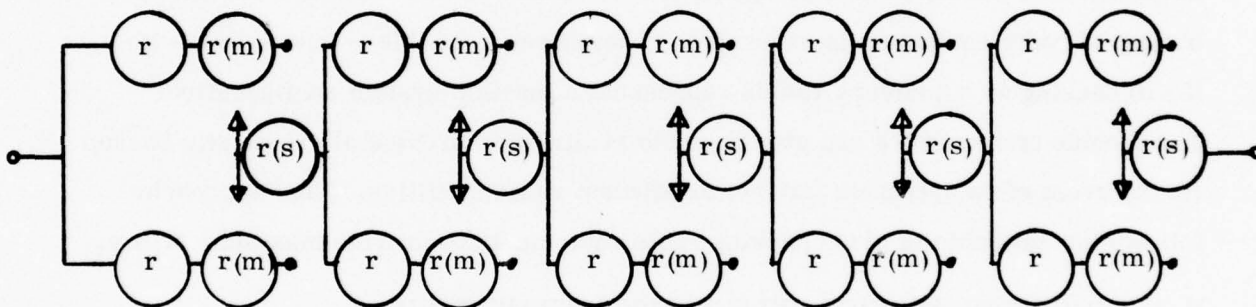

$$R = (2 \{rr(m)\}^5 - \{r(m)\}^{10})r(s)^5$$

C. Parallel Redundant Subsystems With Monitoring and Switching

Reliability With Monitoring And Switching*

Value For r	0.8	0.9
R(B)	0.45	0.67
R(C)	0.21	0.34

*Assume $r(m) = r(s) = 0.9$

fact, the reliability of configuration C drops below that of configuration A in Exhibit 11-2 (the basic non-redundant system). Thus, with multiple monitoring and switching points in a redundant system, it is possible to achieve a reliability below that of a simple non-redundant configuration.

For configuration C with monitoring and switching, it is necessary to increase the basic reliability of system elements to $r = 0.99$ and to utilize monitoring and switching elements with $r(m) = r(s) = 0.99$ in order to achieve the original system C configuration reliability $R = 0.94$.

This is a most important consideration, since the introduction of switching, monitoring, and control (SMC) for automated maintenance support will require increased reliability of the various elements in order to maintain the overall required system reliability. It is also evident, from examination of facility maintenance logs, that the voice signaling system (VSS) for radio control exhibits a relatively high rate of failure (no statistics available). The VSS is a non-redundant element in the current air/ground system. In other words, if the VSS fails, then the primary and backup radio equipments are lost to the system. This is an example of a single non-redundant series element depressing the reliability of the entire system.

For the control of FAA's air/ground radio, it is most effective to concentrate the switching, monitoring, and control at points (or locations) within FAA facilities, i.e., the ARTCC, the Radio Facility, or intermediate points controlled by FAA. Telephone line switching within the Telco physical plant is also an integral part of the service provided, and aircraft radio switching is accomplished by the pilot at his discretion. However, the current control of alternate line switching should be moved into the appropriate FAA Control Site (ARTCC or ATCT).

11.4 AIR/GROUND RADIO SYSTEM AVAILABILITY AND RELIABILITY APPORTIONMENT

Overall air/ground system service availability is a function of the reliability configuration of each of the five elements in the system, plus the maintainability provided for each element. In general, the availability of service may be dramatically

improved by providing parallel redundancy and reasonable repair time for failed elements in the system. However, not all of the five system elements are repairable. The radio channel exhibits a channel reliability dependent upon signal-noise conditions modified by various interference phenomena. Aircraft normally carry two radios which possess a reliability based upon the product of the two unit reliabilities. Air/ground radios in aircraft cannot be repaired while in flight. Availability of service for the control site, telephone line, and radio facility may be designed to any required level by providing redundant elements with specified reliabilities and repair times. The system availability characteristics appear as in Exhibit 11-4. The required system service availability is shown as

$$A_T(R) = 0.9999$$

Availability data as published in SM-6040-20 for ECOM and TCOM service indicate the service reliabilities shown in Exhibit 11-4.

Using the ECOM/TCOM service availabilities and rounding off the service fault location data, it is possible to calculate the element availabilities for ECOM/TCOM as shown in the table included in Exhibit 4.

Since A_T (required) is 0.9999, one can set

$$A_T = A_1 \times A_2 \times A_3 \times R_4 \times R_5 = 0.9999$$

and apportion the required element availabilities or reliabilities equally.

$$\text{Therefore: } A_1 = A_2 = A_3 = R_4 = R_5 = 0.99998$$

Assuming independent element failures, these figures mean that each element will be unavailable or out of service for approximately eleven minutes per year of operation. Since the single element reliabilities are not sufficiently high to achieve this, it is necessary to consider redundant arrangements of elements.

Exhibit 11-4

CURRENT AND REQUIRED AVAILABILITIES

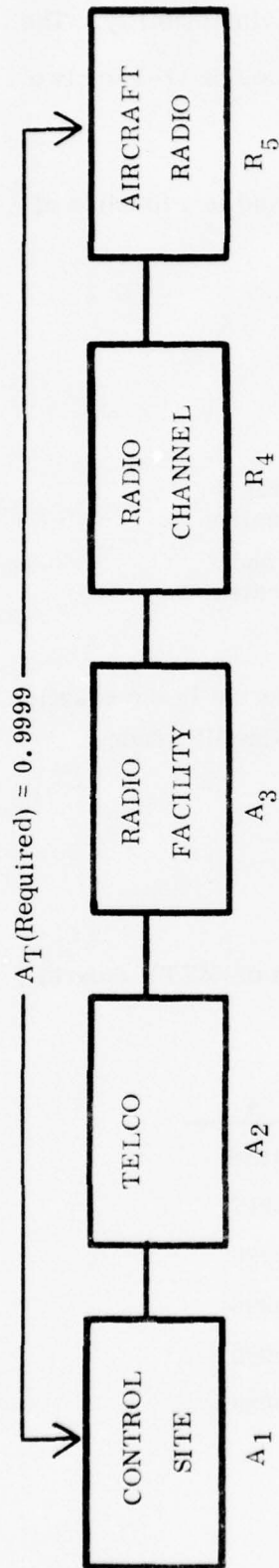

$$A_T = A_1 \times A_2 \times A_3 \times R_4 \times R_5 = 0.9999$$

$$A_T = .99998 \times .99998 \times .99998 \times .99998 \times .99998 = .99998$$

CURRENT A/G SERVICE AVAILABILITIES: A_T (ECOM) = 99.8

A_T (TCOM) = 99.95

A_T (FSS) =

SM 6040 - 20

SYSTEM ELEMENT	SYSTEM ELEMENT AVAILABILITIES	
	AVAILABILITY	TCOM
CONTROL SITE	.99969	.99971
TELCO LINES (CONTROL LINES)	.99907	.99988
RADIO FACILITIES	.99940	.99974
RADIO CHANNEL	-	-
AIRCRAFT RADIO	-	-

11.5 SERVICE AVAILABILITY RELATIONSHIPS

Service availability is a function of both reliability and maintainability. The relationships among the three parameters are expressed in Exhibit 11-5 for two elements in parallel redundancy.

The resulting equation shows that $A(t)$ is time dependent and is a function of λ (the failure rate) and μ (the repair rate), i. e.:

$$A(t) = \frac{\mu^2 + \lambda\mu}{(\lambda + \mu)^2} - \frac{\lambda^2 e^{-2(\lambda + \mu)t}}{(\lambda + \mu)^2} + \frac{2\lambda^2 e^{-(\lambda + \mu)t}}{(\lambda + \mu)^2}$$

$$\begin{array}{l} \text{where } \lambda = \text{Failure Rate} = \frac{1}{\text{MTTF}} \\ \text{where } \mu = \text{Repair Rate} = \frac{1}{\text{MTTR}} \end{array} \quad \left. \vphantom{\begin{array}{l} \text{where } \lambda = \text{Failure Rate} = \frac{1}{\text{MTTF}} \\ \text{where } \mu = \text{Repair Rate} = \frac{1}{\text{MTTR}} \end{array}} \right\} \begin{array}{l} \text{for systems} \\ \text{with constant} \\ \text{failure and} \\ \text{repair rates} \end{array}$$

Because of the exponential decrease of the second and third terms in the equation, the equation for A approaches a steady state that allows the simplification:

$$A_{ss} = \frac{\mu^2 + 2\lambda\mu}{(\lambda + \mu)^2} \quad (\text{steady state availability})$$

The following illustrates typical values for A as a function of MTTR (hours) and MTTF (hours).

MTTF	λ	MTTR	μ	A
100	.010	50	.020	0.8888
100	.010	20	.050	0.9917
500	.002	10	0.100	0.9996
1000	.001	20	.050	0.9996
2000	.0005	20	.050	0.9999
5000	.0002	20	.050	0.99998

AVAILABILITY/MAINTAINABILITY/RELIABILITY RELATIONS

(REPAIRABLE SYSTEM)

- For a time interval from t to $t+\Delta t$, calculate the probability that a facility has failed at the end of the interval Δt .
- Define Reliability $\equiv P(t) = e^{-\lambda t}$: $\lambda \equiv$ constant failure rate
Maintainability $\equiv M(t) = 1 - e^{-ut}$: $u =$ constant repair rate
- Let $P(t) =$ probability that at time t , Facility is operating
 $P_1(t) =$ probability that at time t , Facility is not operating
i.e. $P(t) = 1 - P_1(t)$
- Let $P_1(t+\Delta t) =$ probability that at end of interval Δt , facility is not operating (failed).
- Conditions of Failure (a) at time t facility is operating and fails during Δt
(b) at time t facility has failed and has not been repaired during Δt .

$$P_a(t+\Delta t) = P(t)(1 - e^{-\lambda\Delta t}) \approx P(t)\lambda\Delta t$$

$$P_b(t+\Delta t) = P_1(t)e^{-ut} \approx P_1(t)(1 - u\Delta t)$$

$$P_1(t+\Delta t) = P_a + P_b = P_1(t)(1 - u\Delta t) + P(t)\lambda\Delta t$$

$$\frac{P_1(t+\Delta t) - P_1(t)}{\Delta t} = -uP_1(t) + \lambda P(t)$$

$$P_1'(t) = -uP_1(t) + \lambda\{1 - P_1(t)\}$$

$$P_1'(t) + (u+\lambda)P_1(t) - \lambda = 0 \quad \text{with } P(0) = 1 + P_1(0) = 0$$

$$P_1(t) = \frac{\lambda}{\lambda+u} + \frac{\lambda}{\lambda+u} e^{-(\lambda+u)t}$$

Exhibit 11-5 (Cont.)

AVAILABILITY/MAINTAINABILITY/RELIABILITY RELATIONS
(REPAIRABLE SYSTEM)

• If $Q(t)$ is defined as probability that all facilities (i.e. 2 or more) fail, then $Q(t) = \prod P_i$ $i = 1, 2, \dots$

• For case of 2 facilities:

$$Q(t) = \{P_1(t)\}^2 = \frac{\lambda^2 - 2\lambda^2 e^{-(\lambda+u)t} + \lambda^2 e^{-2(\lambda+u)t}}{(\lambda+u)^2}$$

• System Availability is given by: $A(t) = 1 - Q(t)$

$$A(t) = \frac{u^2 + 2\lambda u}{(\lambda+u)^2} - \frac{\lambda^2 e^{-2(\lambda+u)t}}{(\lambda+u)^2} + \frac{2\lambda^2 e^{-(\lambda+u)t}}{(\lambda+u)^2}$$

For an element service availability of 0.99998, as required by the availability apportionment, the element should exhibit a MTTF equal to 5000 hours and a MTTR equal to 20 hours. It is allowable to increase the failure rate if the repair rate is correspondingly increased.

Regarding maintainability, i.e., mean time to repair (MTTR), Exhibit II-6 shows an analysis of data for ZOA¹. The data refer to restoral of service rather than MTTR. Control site service is restored within an average time of 0.6 hours.

Telephone line service is restored within an average time of 1.14 hours, with an average outage duration time of 2.3 hours. (This difference probably indicates administrative time lapse for FAA-Telco coordination). Facility (RCAG) service is restored with an average time of 3.15 hours. For an automated maintenance support subsystem, these service restoral times should approach zero, i.e., there will be an on-demand switching capability for alternate service. The primary interest lies in establishment of a realistic mean time to repair for each of the system's elements. For example:

- Control Site. Maintenance service is available at the control sites, so that an assigned MTTR of 20 hours appears to be more than adequate.
- Telco Lines. Service restoral time and mean time to repair are equivalent with regard to telephone service since the primary requirement is to obtain an operational circuit--that is, Telco can restore service by providing another circuit or by repairing a failed circuit according to their procedures.
- Radio Facility. The specified MTTR for the solid state radio equipment is 30 minutes. Thus, the principal contribution to total MTTR for radio facilities (remotely located at some distance from maintenance support) will be facility travel time.

Exhibit II-7 illustrates a Facility Travel Exercise for ZOA.² It is noted that the longest current travel time is six hours (Mina and Reno in Winter). A travel

1. Provided by E. Milani TID-ZOA.

2. Provided by E. Milani TID-ZOA

Exhibit 11-6

MEAN TIME TO RESTORE SERVICE

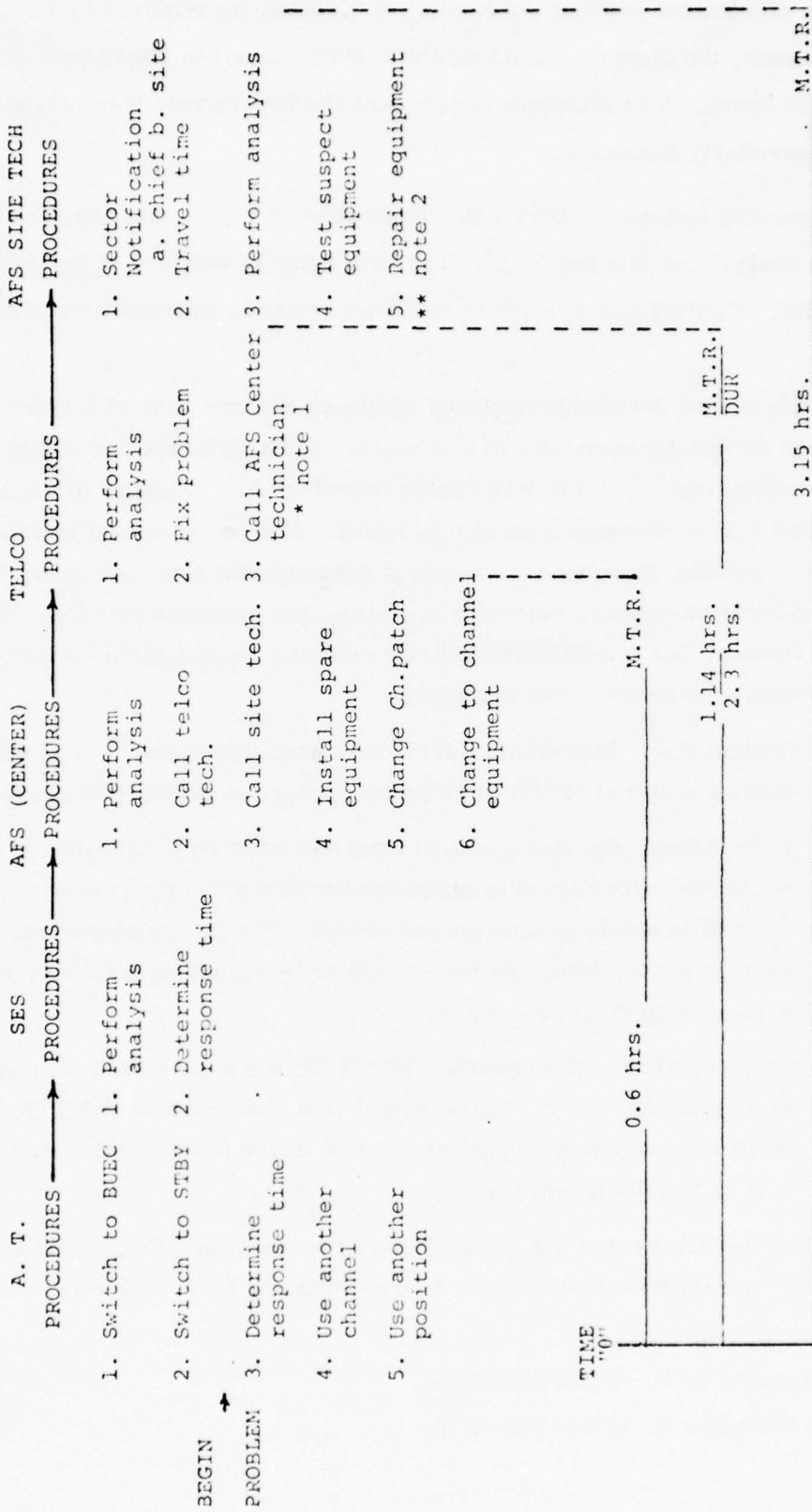

NOTES: *1. Telco Duration and M.T.R. are their figures. In checking against FAA STARS 6 month Report, from ZOA Center, it is found a DUR of 1.33 hrs. for 169 outages...

**2. Per RIS SM 60-40-20 FISCAL YEAR 1975, the KCAG M.T.R. for equip. failure is 2.27 and unscheduled causes at 3.06. In checking the STARS 6/mon Report from ZOA, the KCAG M.T.R. is 3.15 hours for equip. failure.

Exhibit 11-7

FACILITY TRAVEL EXERCISE

SITE	One Way Travel-Mi.	Summer Time	Winter Time	Snow Cat	4/Whl Drive	REMARKS
Angels Camp	15/60	30/1:15	30/1:15	No	Yes	Yes There every day
Fallon	10	1/2 hr.	1/2 hr.	No	No	No Subsector
Ferndale		1:45	1:45			Subsector
Fresno	23	45 min.	45 min.	No	No	No Fog-add 30 min. one way
Mina	35/40	45 min.	2/6 hrs.	Some time	Yes	Yes Everyday at vortac Sector HDQ 110 mi. from site-8/10 mi. dirt road
Mt. View	28	1:15 min.	1:15 min.	No	No	No 3 times a week
Mr. Tamalpais		1:15	1:15	No	No	No
Priest		1:45	1:45	No	No	No
Red Bluff		5 min.	5 min.	No	No	No
Reno	40	1 hr.	2 to 6 hr.	Some time	Yes	No
Sacramento		10 min.	10 min.	No	No	No
Tonopah	10	20 min.	20 min.	No	Yes	No RCAG Road-Dirt Radar Road-Paved
Reno RTR BUEC		30 min.	30 min.			
Ukiah RTR BUEC		30 min.	30 min.			

Radar BUEC's There is 24 hour coverage at these facilities;
therefore they have immediate response.

time of six hours plus an average repair time of 30 minutes is consistent with an assigned MTRR of 20 hours. It is assumed that automated performance monitoring and testing at the radio facilities will provide near real-time identification of failures to the maintenance sector office.

The use of an MTTR of 20 hours is an upper bound that appears reasonable in terms of administration time, travel time and actual repair time. The scope of the current study did not allow an examination of the entire maintenance, logistics, and supply structure which must support the maintainability parameters chosen. The provision of spare equipments, the degree of on-site repair, and the turn-around times for logistical support must be consistent with an overall maintenance system operation.

11.6 STANDBY REDUNDANCY AND RELIABILITY

For air-ground radio facilities it is of interest to determine the main-standby ratios of radio equipments. Current practice utilizes a one-to-one ratio of one standby equipment for each primary equipment. For example, a radio facility with eight UHF and eight VHF radio frequencies contains 32 radio equipments (16 main and 16 standby). A substantial savings in equipment and maintenance costs can be realized by utilizing a configuration which assigns some number k of spare radios as backup to n primary radios ($k < n$).

Assuming that n identical radio equipments are normally in operation at a particular facility, what is the probability that k backup equipments will provide the required radio facility availability? The specified MTBF is 10,000 hours for the ITT solid state transmitters and receivers. For a transmitter-receiver combination the MTBF is therefore 5,000 hours. If there are n radio equipments operating at a radio facility and there are k backup equipments, the system will fail if more than k equipments fail. The probability of system success where the system is comprised of n equipments and k backup equipments can be determined from the binomial distribution:

$$R_s = \sum_{j=0}^k \frac{n!}{j! (n-j)!} p^{n-j} q^j$$

Where n = number of equipments

k = number of backups

p = probability of an equipment operating for time T

q = probability of an equipment failing during time T

A radio facility maintainability will be assumed that provides an MTTR of 20 hours. That is, the elapsed time between detection of equipment failure and equipment repair will average 20 hours.

$$\text{Thus, } R_{eq} = e^{-\lambda T} \quad \text{with } \lambda = \frac{1}{5000}$$
$$T = 20$$

$$\text{or } R_{eq} = p = 0.99600$$
$$(1 - R_{eq}) = q = 0.00400$$

Exhibit 11-8 shows the results expressing system reliability R_s as a function of the number n of primary radio equipments at a facility and the number k of spare radio equipments at the same facility. The reliabilities listed approach 1 rapidly as the number of spare radio equipments is increased. For 20 radio equipments, it is necessary to provide only three spares in order to achieve a reliability of 1.0000.

Practically, this means it is cost-effective to place primary equipments in clusters as large as possible, in order to gain maximum utilization of spare radios, i.e., for 10 or 20 primary radio equipments, it is required to provide only three spares.

A feasible configuration for A/G facility radio equipments is to place n fixed tuned primary radio equipments at the facility backed up by k tunable spare radio equipments. The failure of a primary radio would be corrected by insertion of a spare transceiver tuned to the appropriate frequency. The failed radio would be repaired and placed back in service within an average of 20 hours.

The same redundancy analysis may be applied to the telephone lines in order to determine the appropriate ratio of spare lines to primary lines.

The mean time between failures (MTTF) for the Bell System telephone lines is 1800 hours, which is used as the Western Region objective for leased service performance.¹

1. "FAA A/G Service Western Region Monthly Performance Report," Pacific Telephone, May, 1976.

Exhibit 11-8

SYSTEM RELIABILITY - R_s

Number of Backups	For n = 4 radio equipments
k	
1	0.9999
2	1.0000
	For n = 6 radio equipments
k	
1	0.9997
2	1.0000
	For n = 8 radio equipments
k	
1	0.9995
2	1.0000
	For n = 10 radio equipments
k	
1	0.9992
2	0.9999
3	1.0000
	For n = 15 radio equipments
k	
1	0.9983
2	0.9999
3	1.0000
	For n = 20 radio equipments
k	
1	0.99709
2	0.9999
3	1.0000

Thus

$$\lambda = \frac{1}{1800} \quad \text{and} \quad T = 20 \text{ hours.}$$

$$R_{\text{Telco}} = e^{-\lambda T} = 0.9889$$

$$R_{\text{Telco}} = p = 0.9889$$

$$(1 - R_{\text{Telco}}) = q = .0111$$

Exhibit 11-9 shows the results for provision of spare telephone circuits. It is evident that three spare or redundant telephone lines are required to provide backup capability for radio facilities that utilize up to eight circuits. When $n = 10$ primary lines, the number of spare lines increases to four.

The analysis has been performed for a national average MTBF of 1800 hours. As can be noted in Exhibit 11-10, the mean time between outage varies considerably as a function of facility location. (MTBO = 75 days = 1800 hours is the national average). For actual application, it would be most cost-effective to calculate telephone line redundancy ratios for each specific facility in order to accommodate the considerable difference in performance of telephone service.

A lower bound of the cost-savings relative to radio equipment is shown in Exhibit 11-11. The exhibit is based on current use of one-to-one backups for radio equipments, so that, for example, the entry of 2,173 frequencies for ECOM requires 4,346 ($2 \times 2,173$) radio equipments (transmitter and receiver). The 2,173 frequencies assigned to 495 RCAGs results in an average of four radio equipments per facility, which, according to Exhibit 11-8, require two spares. Therefore, the current average of eight equipments per facility (four primary and four backup) may be reduced to six equipments per facility (four primary and two backup). The net change in equipment is a reduction of 1,426 radios. The TCOM redundancy ratio is more cost-effective, because there are more equipments per facility (i. e., 18). This is reduced to 12 (nine primary and three backup), resulting in a net reduction of 2,570 radios. The total reduction of radio equipments amounts to a capital savings of approximately 16 million dollars. The recurrent costs are decreased by cost-savings in maintenance of approximately 6 million dollars per year. The spare radio equipments will be of the BUEC Transceiver type, which cost approximately \$3,500.00 (relative to a \$4,000.00

Exhibit 11-9

TELCO CIRCUIT REDUNDANCY - R_{Telco}

Number of Spare Lines	For n = 4 primary lines
k	
1	0.9993
2	0.9999
3	1.0000
	For n = 6 primary lines
k	
1	0.9982
2	0.9999
3	1.0000
	For n = 8 primary lines
k	
1	0.9967
2	0.9999
3	1.0000
	For n = 10 primary lines
k	
1	0.9948
2	0.9993
3	0.9999
4	1.0000

Exhibit 11-10

INDIVIDUAL CIRCUIT PERFORMANCE -

SIX MONTH MTBO, OAKLAND AREA

1GR1042	LOS ALTOS	999	1GR1053	MT TAMALPAIS	90
1GR1043	LOS ALTOS	999	1GR1091	FRESNO	90
1GR1051	MT TAMALPAIS	999	1GR1124	FALLON	90
1GR1090	MT TAMALPAIS	999	1GR6031	RENO	90
1GR6018	SACRAMENTO	999	1GR6032	RENO	90
1GR6025	FALLON	999	1GR779	TONOPAH	90
1GR6028	FALLON	999	1GR780	RED BLUFF	90
1 GR6029	RENO	999	6GR114	ANGELS CAMP	90
1GR6030	RENO	999	6GR118	ANGELS CAMP	90
1GR6036	PRIEST MT	999	6GR93	LOS ALTOS	90
5GR103	FRESNO	999	1GR1081	ANGELS CAMP	60
6GR105	FRESNO	999	1GR1092	PRIEST MT	60
6GR107	FRESNO	999	1GR1125	FERNDALE	60
6GR109	FRESNO	999	1 GR953	RED BLUFF	60
6GR111	FALLON	999	6GR101	TONOPAH	60
6GR115	ANGELS CAMP	999	6GR751	RENO	60
6GR116	ANGELS CAMP	999	6GR97	RED BLUFF	60
6GR120	ANGELS CAMP	999	1GR6463	FRESNO	45
6GR122	FERNDALE	999	1GR1021	PRIEST MT	36
6GR123	FERNDALE	999	6GR90	LOS ALTOS	36
6GR124	FERNDALE	999	6GR251	RED BLUFF	26
6GR231	ANGELS CAMP	999	1GR1019	PRIEST MT	18
6GR98	RED BLUFF	999	6GR108	FRESNO	18
1GR1020	PRIEST MT	180	1GR1047	TONOPAH	83
1GR1052	MT TAMALPAIS	180			
1GR1126	RENO	180			
1GR6026	FALLON	180			
1GR6027	FALLON	180			
1GR6401	ANGELS CAMP	180			
1GR6451	UKIAH	180			
1GR6452	UKIAH	180			
1GR6453	UKIAH	180			
1GR6454	UKIAH	180			
6GR106	FRESNO	180			
6GR110	FALLON	180			
6GR112	FALLON	180			
6GR113	FALLON	180			
6GR119	ANGELS CAMP	180			
6GR754	RENO	180			

Note: 999 = No Outage, or 100% Availability

Exhibit 11-11

ALL REGION RADIO EQUIPMENT COST TRADE-OFF

	No. of Facilities	No. of Freqs.	No. of Equipments	Av. equipments per site (ratio 1/1)	Av. equipments per site (ratio 1/2)	No. equipments 6/site (4p + 2s)	Change
ECOM	495	2173	4346	8	6	2970	-1376
TCOM	425	3835	7670	18	(ratio 1/3)	12/site (9p + 3s)	-2570
<hr/>							
						TOTAL	-3946

COST INCREMENT

CAPITAL 3946 x \$4000. = 15.78 million dollars

RECURRING $\frac{3946 \times 150 \text{ pts}}{2000}$ x \$20000 = 5.9 million dollars per yr.

cost for a separate fixed tuned transmitter and receiver).

It is difficult to assess the change in leased circuit costs since, in some cases (where SS-1 is used), there will be an increase in leased circuits, while in other cases (where LASS is used) there will be a decrease in leased circuits. Additionally, the redundancy ratio for leased circuits will vary with each facility due to the range of Telco performance in different areas.

11.7 SERVICE AVAILABILITY (CONTROL SITE-TELCO-RADIO FACILITY)

The system element service availabilities necessary in order to achieve the overall availability of 0.9999 can be estimated. Exhibit 11-4 shows that each element should exhibit an availability:

$$R = 0.99998.$$

The following considerations apply to the control site, Telco, and radio facility elements.

11.7.1 Control Site

The control site is divided into two sub-elements, the audio system and the switching, monitoring, and control (SMC). Each sub-element should approach a service availability of 0.99999. The SMC will comprise a centralized processor serving all radio positions, so that its availability will likely be attained by using dual processors.

11.7.2 Telco

The Telco service requires an availability of 0.99998, consistent with the redundancy calculations for spare circuits described in section 11.6 of this report.

11.7.3 Radio Facility

The radio facility is comprised of the primary sub-elements shown. The loss of any single element will result in a radio channel failure. As shown in section 11.6 of this report, the redundant radio equipments will provide a radio equipment service availability approaching 1. It is arbitrarily assumed that the facility damage-probability is extremely low, meaning that its physical availability of service approaches 1.

The service availability for commercial-standby power may be estimated from data presented in SM 6040 for FY-74. For RCAGs in all regions, the following apply:

No. of commissioned facilities - 495

Power Source	No. of Outages	No. of Hours
(1) Commercial Power	96	87
(2) Engine Generator	291	391

$$\begin{array}{l}
 \text{Thus: } \lambda_1 = \frac{1}{\text{MTBF}} \approx 22 \times 10^{-6} \\
 \mu_1 = \frac{1}{\text{MTTR}} \approx 1 \\
 \lambda_2 = \frac{1}{\text{MTBF}} \approx 66 \times 10^{-6} \\
 \mu_2 = \frac{1}{\text{MTTR}} \approx 0.66
 \end{array}
 \left. \begin{array}{l} \\ \\ \\ \end{array} \right\} \begin{array}{l} \text{commercial} \\ \text{power} \\ \\ \text{engine generator} \end{array}$$

For parallel redundant elements with different λ, μ characteristics, the service availability is:

$$A = \frac{\mu_1 \mu_2 + \lambda_1 \mu_2 + \lambda_1 \mu_1}{(\lambda_1 + \mu_1) (\lambda_2 + \mu_2)}$$

For the set $(\lambda_1 \mu_1)$ and $(\lambda_2 \mu_2)$, given:

$$A \approx 1$$

Therefore, in order to attain a radio facility service availability of 0.99998, the SMC element should assume the same value (i.e., 0.99998), since the other three elements are approximately equal to 1.

$$A \text{ (SMC)} = 0.99998.$$

The SMC complex comprises a digital processing capability that functions to perform PTT, Primary-Alternate Radio Equipment Selection, Power Source Selection, Performance Monitoring, Radio Configuration Testing, and Line Switching and Testing. The SMC functions are performed by a micro or mini-processor, so that a dual processor is required to attain the specified availability of service.

11.8 SERVICE AVAILABILITY (AIRCRAFT RADIOS)

The service availability of aircraft radios is equivalent to the reliability of parallel, non-repairable elements. The MTBF for aircraft radios varies with manufacturer and type. Two sample values for Collins and King are:

<u>Radio</u>	<u>MTBF</u>
Collins AN/GRC-171	5,000 hours
King KTR 9100 A	4,000 hours

If a constant failure rate is assumed, and it is further assumed that aircraft flight duration $T = 2$ hours, then it is possible to calculate aircraft radio service availability. A value of $MTBF = 1,000$ hours is used as a bound to include all aircraft radio types. Thus:

$$\begin{aligned}
 MTBF &= 1,000 \text{ hours} & \lambda &= .001 & T &= 2 \text{ hours} \\
 R_{AC} &= e^{-\lambda T} = 0.9998
 \end{aligned}$$

For two radios in parallel, the equivalent service availability becomes:

$$A_{AC} = 2 R_{AC} - R_{AC}^2 \approx 1$$

These calculations depend upon the aircraft radios being operational (i. e., checked out) prior to flight operations.

11.9 SERVICE AVAILABILITY (RADIO CHANNEL)

It is evident that, of the 5 elements in series, the radio propagation channel exhibits the poorest relative reliability and is therefore the weakest link in the air/ground system. An in-depth analysis and evaluation of the radio propagation channel is beyond the scope of the current contract. However, an approximation of

service is possible by consideration of some of the parameters involved.

In general, radio link performance is a function of the signal/noise ratio attainable, modified by various interference phenomena that degrade the signal. Since a major portion of air/ground radio interference is self-generated, an increase in signal power does not provide a solution for interference on the signal channel.

The following factors influence radio channel performance:

- Signal-noise ratio
- Co-channel interference
- Adjacent channel interference
- Intermodulation products
- Desensitization

11.9.1 Signal-Noise Performance

The noise figure for solid-state receivers is derived from the specified sensitivity of the equipments. Exhibit 11-12 shows the calculation which results in an:

$$F_R = 13.2 \text{ dB}$$

Exhibit 11-13 shows a representative receiving system with the calculated system noise:

$$N_S = -113.6 \text{ dBm}$$

This is the total available noise power referred to the receiver input terminal.

Exhibit 11-14 shows the down-link power budget for en route and terminal service, assuming an aircraft transmitter power of 25 watts.

Exhibit 11-12

SOLID STATE RECEIVER NOISE FIGURE

RECEIVER SENSITIVITY - $3\mu\text{V}$ (50 ohms)

$$\frac{S + N}{N} \text{ (OUT)} = 10 \text{ dB} \quad \frac{S}{N} \text{ (OUT)} = 9.5 \text{ dB}$$

$$\text{SIGNAL POWER (IN)} = \frac{E^2}{4R} = -103.4 \text{ dBm}$$

$$\text{NOISE POWER (IN)} = kT_0B = -128.4 \text{ dBm} \quad (B = 36 \text{ kHz}, T_0 = 290^\circ\text{K})$$

$$\frac{S}{N} \text{ (IN)} = 128.4 - 103.4 = 25 \text{ dB}$$

FOR AM-DSB DETECTION:

$$\left(\frac{S}{N}\right)_i = \frac{1}{m^2} \left(\frac{S}{N}\right)_0 \quad m = 30\% \text{ modulation}$$

$$\left(\frac{S}{N}\right)_i + 10.5 \text{ dB} = \left(\frac{S}{N}\right)_0$$

$$\text{DETECTION LOSS} = D = 10.5 \text{ dB}$$

SIGNAL/NOISE GAIN (G) WITH POST DETECTION FILTERING

$$G = \frac{\text{IF. BANDWIDTH}}{\text{AF. BANDWIDTH}} = \frac{36}{5.4} = 8.2 \text{ dB}$$

$$\text{NOISE FIGURE } F_R = \frac{S}{N} \text{ (IN)} - D + G - \frac{S}{N} \text{ (OUT)}$$

$$= 25 - 10.5 + 8.2 - 9.5$$

$$F_R = 13.2 \text{ dB}$$

Exhibit 11-13

SYSTEM NOISE AT RECEIVER INPUT

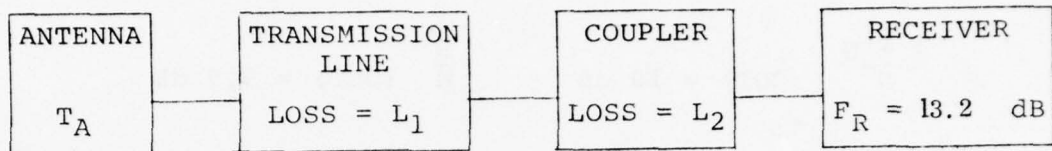

SYSTEM NOISE TEMPERATURE: T_S

$$T_S = \frac{T_A}{L_1 + L_2} + T_0 \left(1 - \frac{1}{L_1 + L_2}\right) + T_0 \left(1 - \frac{1}{L_2}\right) + T_0 (F_R - 1)$$

$$\text{ANTENNA TEMPERATURE} = \frac{15 \text{ dB}}{KT_0 B} = 31.62 \times 290 = 9170^\circ\text{K}$$

$$\text{TRANSMISSION LINE LOSS} - L_1 = 2 \text{ dB} (1.58)$$

$$\text{COUPLER LOSS} - L_2 = 2.5 \text{ dB} (1.78)$$

$$T_S = 2729 + 204 + 127 + 5711$$

$$T_S = 8831^\circ\text{K}$$

SYSTEM NOISE AT RECEIVER INPUT:

$$N_S = KT_S B = 1.38 \times 10^{-23} \times 8831 \times 36 \times 10^3$$

$$N_S = -113.6 \text{ dBm.}$$

Exhibit 11-14

AIR/GROUND POWER BUDGET

TRANSMITTER POWER (AIRCRAFT)		25 watts = +44 dBm
SYSTEM LOSS		= 12dB
LOW PASS FILTERS		
TRANSMISSION LINES		
ANTENNAS		
MAINTENANCE		
FREE SPACE LOSS (125 MHz)	(ENROUTE)	150 nm = 123 dB
	(TERMINAL)	60 nm = 115 dB
ANTENNA GAINS (GND + A/C)		= 0 dB
<hr/>		
AVAILABLE SIGNAL POWER		
		ENROUTE = -91 dBm
		TERMINAL = -83 dBm

AVAILABLE SIGNAL/NOISE:

$$\frac{S}{N} \text{ (ENROUTE)} = 113.6 - 91 = 22.6 \text{ dB}$$

$$\frac{S}{N} \text{ (TERMINAL)} = 113.6 - 83 = 30.6 \text{ dB}$$

SIGNAL POWER MARGINS: (AIRCRAFT Tx. POWER = 25 WATTS)

$$\text{ENROUTE: } 22.6 - 25 = -2.4 \text{ dB}$$

$$\text{TERMINAL: } 30.6 - 25 = +5.6 \text{ dB}$$

SIGNAL POWER MARGINS: (AIRCRAFT Tx. POWER = 10 WATTS)

$$\text{ENROUTE: } 18.6 - 25 = -6.4 \text{ dB}$$

$$\text{TERMINAL: } 26.6 - 25 = +1.6$$

As can be seen from Exhibit 11-14, the signal margins are not adequate for the extremely reliable performance requirement (i. e. , 0. 99998). Additionally, a large number of aircraft operate radio transmitters at ten watts, which degrades the signal margin another 4 dB. The reciprocal up-link also operates at the ten watt power output level, which indicates similar power margins available on the up-link. The numbers shown in Exhibit 11-14 are calculated for the boundary of the en route and terminal service volumes and may be considered as a worst case. However, no allowances have been assigned for expected variations in the signal.

The available signal powers shown in Exhibit 11-14 are subject to variations caused by antenna patterns and signal transmission characteristics of the radio path and radio system.

The attainment of solid (gapless) coverage over the service volume is a function of both signal power and antenna height. The lobe structure of the antenna pattern is based upon the antenna height, expressed in half-wave lengths. The number of lobes will therefore be proportional to antenna height and frequency. Exhibit 11-15 shows optimum antenna heights for solid coverage as a function of frequency.¹ Note that the optimum heights for VHF and UHF differ considerably. Antennas placed higher than the optimum will create additional lobes that form at high elevation angles and compress the lobing structure toward the lower elevation angles. The FAA's VHF and UHF antennas are normally mounted at equal heights. The heights of antennas deployed vary between 25 feet and 125 feet. In many instances there may be coverage gaps introduced by lobing that is not compensated by an adequate signal margin.

The radio system loss of 12 dB, as shown in Exhibit 11-14, is a mean value with an estimated standard deviation of 4. 7 dB.² For the en route service volume case of transmission over 150 nm at 125 MHz, the standard deviation for path loss variations (fading) is approximately 7 dB.³ Assuming normal distributions for

1. Reed and Russell, "UHF Propagation."

2. "Air Traffic Control Communications" Task A. Part 4 BTL. Dec. 1957.

3. Ibid.

Exhibit 11-15

OPTIMUM ANTENNA HEIGHTS FOR MAXIMUM SOLID COVERAGE RANGES

(First Interference Minimum at Pseudo-Brewster Angle)

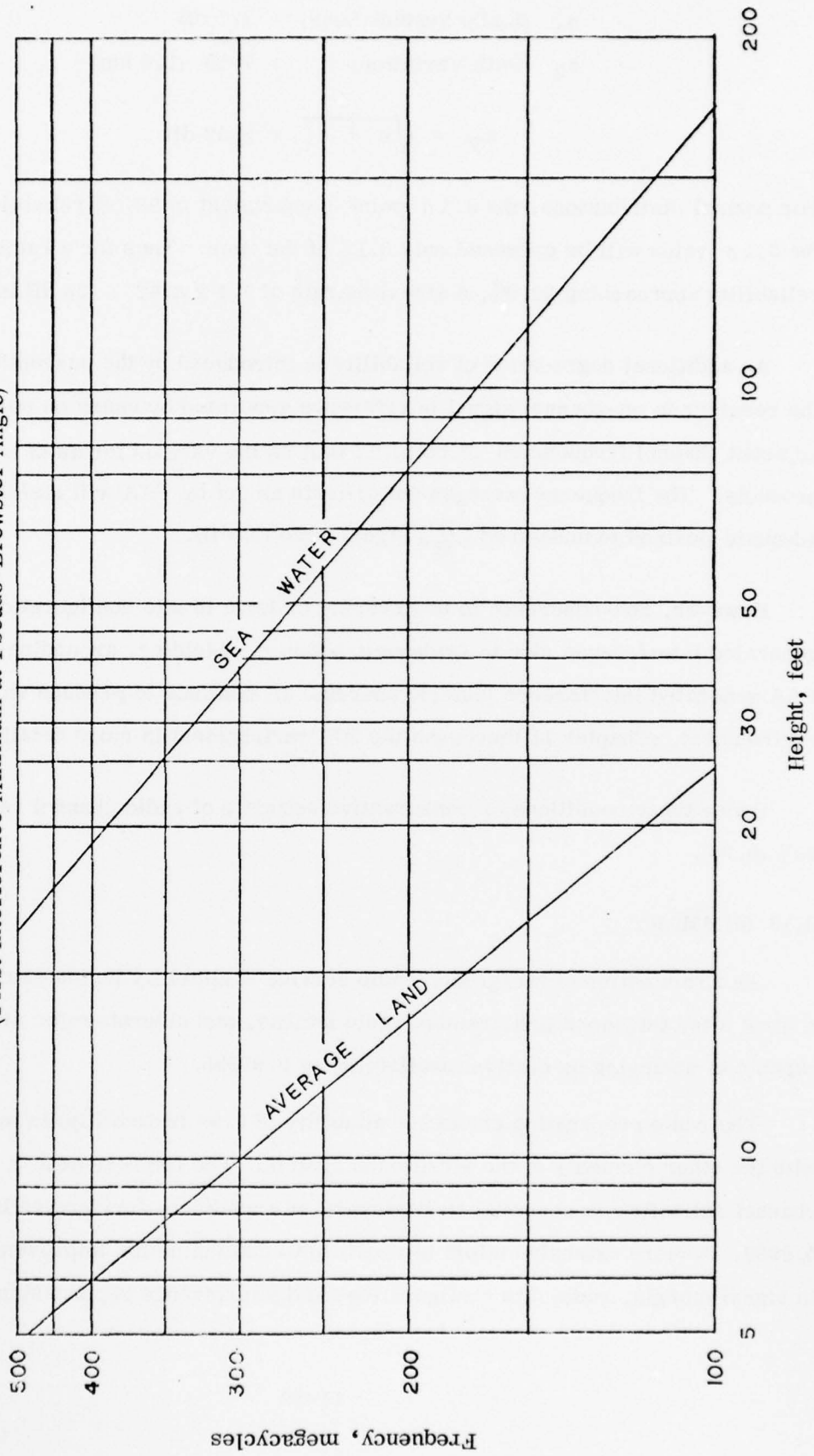

these variations, a RMS addition of the standard deviations should be allowed, i.e.,

$$\sigma_1 \text{ (Radio System Loss)} = 4.7 \text{ dB}$$

$$\sigma_2 \text{ (Path Variation)} = 7 \text{ dB (150 nm)}$$

$$\sigma_T = \sqrt{\sigma_1^2 + \sigma_2^2} = 8.42 \text{ dB}$$

For normal distributions, the 3.1σ point is equivalent to 99.9% reliability--i.e., the 3.1σ value will be exceeded only 0.1% of the time. Thus for a radio channel reliability approaching 99.9%, a signal margin of $3.1 \times 8.42 = 26 \text{ dB}$ is required.

An additional degradation of reliability is introduced by the susceptibility of the receiver to on-channel signal interference generated by users on co-channel or adjacent channel frequencies or both, as well as the various forms of intermodulation products. The frequency management criteria as set by FAA will maintain an adequate desired to undesired ($\frac{D}{M}$) signal ratio (15 dB).

However, non-adherence to engineering criteria in site configurations, internally generated interference (due to inadequate bonding, shielding, grounding), and non-FAA generated interference (outside sources) all continue to produce an RFI environment. (Chapter 15 discusses the RFI environment in more detail.)

Under these conditions, a conservative estimate of radio channel reliability is 90% (0.90).

11.10 SUMMARY

An Examination of air/ground radio service availability indicates that the control site, telephone link, remote radio facility, and aircraft radio system are capable of achieving an element availability of 0.99998.

The radio propagation channel availability of 0.90 (reliability) is inconsistent with the other elements of the air/ground system. The improvement of radio channel reliability is essential to attainment of a complete service availability of 0.9999. A more extensive effort is required to determine the improvement factors in signal margin, radio site configurations and interference suppression. It is

evident that air/ground service availability can never exceed the value of its least reliable element. Therefore, the air/ground channel service availability may be expected to assume a value of 0.90, unless a vigorous improvement program is initiated.

12

AIR/GROUND RADIO NETWORK SWITCHING AND CONTROL

12.1 INTRODUCTION

As shown in Exhibit 10-29 (Chapter 10), the costs of leased circuits accounts for approximately one-third of the recurring air/ground facility costs. Nationally, air/ground radio leased circuit expenditures occupy a significant portion of the FAA communications budget. Exhibit 12-1 shows a summary of annual circuit costs. As an approximation to projected annual costs, an analysis of the Oakland Area was performed. Exhibit 12-2 shows the current ZOA-RCAG leased circuit costs as applied to each facility. Exhibit 12-3 shows projected FSS costs assuming that each FSS listed is remoted to the Oakland Center FSS-Hub. An annual tariff of \$14.40 was used, which represents the average rate for a voice circuit. The number of radio frequencies is indicated for each facility.

Finally, the 47 VOR/LRCO/SFO facilities controlled by the current FSSs were costed as connected directly to the Oakland FSS-Hub. The total annual costs for such a projection are listed in Exhibit 12-4. If it is assumed that ZOA's annual leased circuit costs of \$622,264 represent an average value, then the national projected figure would amount to:

$$20 \times \$622,264 = \$12,445,280 \text{ per year.}$$

The projection indicates a near doubling of leased circuit costs due to the FSS reconfiguration.

Also of interest is the indication of the number of FSS-Hub terminations required by straightforward remoting of all FSS air/ground outlets: $94 + 83 = 177$.

Exhibit 12-1

A/G RADIO GROUND LEASED CIRCUIT COSTS¹

<u>Function</u>	<u>Costs</u>
Primary Ckts. to RCAGs	\$3,985,975
Control and Voice to VORs	1,552,867
SS-1	1,220,686
Ckts. to RCOs and RTRs	944,927
BUEC	<u>48,127</u>
TOTAL	\$7,752,582

1. Provided by D. Rhoades, ARD-200.

Exhibit 12-2

ZOA-RCAG LEASED CIRCUIT COSTS

<u>Name</u>	<u>No. Ckts.</u>	<u>Annual Cost (\$ per year)</u>
Angels Camp	9	23,356
Fallon (incl. BUEC)	9	44,917
Ferndale	4	13,829
Fresno	8	22,886
Mina	2	5,143
Mountain View	4	5,400
Mt. Tamalpais	4	9,229
Priest	5	19,092
Red Bluff	5	18,219
Reno	7	18,115
Sacramento	1	2,046
Tonopah	6	23,156
Ukiah (BUEC)	4	<u>7,648</u>
TOTAL		\$213,036

Exhibit 12-3

FSS PROJECTED COSTS TO FSS CENTER

<u>FSS</u>	<u>No. Freq.</u>		<u>Distance</u>		<u>Cost/ckt/yr/mi</u>	
Arcata	7 f	x	260.77m	x	14.40	= 26,285
C City	5 f	x	313.62	x	14.40	= 22,580
Fresno	7 f	x	133.09	x	14.40	= 13,415
Lovelock	7 f	x	263.21	x	14.40	= 26,531
Marysville	7 f	x	109.22	x	14.40	= 11,009
Montague	5 f	x	291.81	x	14.40	= 21,010
Oakland	5 f	x	16.82	x	14.40	= 1,211
Paso Robles	7 f	x	210.24	x	14.40	= 21,192
Red Bluff	7 f	x	179.78	x	14.40	= 18,121
Reno	6 f	x	180.0	x	14.40	= 15,552
Sacramento	6 f	x	72.2	x	14.40	= 6,238
Salinas	6 f	x	64.97	x	14.40	= 5,613
Stockton	7 f	x	47.41	x	14.40	= 4,778
Tonopah	6 f	x	264.63	x	14.40	= 22,864
Ukiah	6 f	x	125.84	x	14.40	= 10,872
ANNUAL COST						\$227,271

Exhibit 12-4

ZOA PROJECTED ANNUAL LEASED CIRCUIT COSTS

<u>Function</u>	<u>No. of Freq.</u>	<u>Ckt. Mileage</u>	<u>Annual Cost</u>
FSS	94	See Table 3-3	\$227,271
VOR/CRCO/SFO	83	12,638	181,957
RCAG	-	-	213,036
TOTAL			\$622,264

It appears that simply reconfiguring FSS facilities by remoting them directly to the Center FSS-Hub is extremely cost-ineffective and that a more realistic approach lies in implementation of an automated switched network responsive to all radio service requirements. Such an approach will allow a substantial reduction in circuit miles, increased flexibility of operations and a reduction in personnel.

The principal discussion involves the en route and flight service radio operations, since the major leased circuit mileage is accumulated by those functions. Terminal radio operations are localized, so that leased circuit costs are not normally a major factor.

12.2 NETWORK STRUCTURE

En route air traffic control operations require an almost 100 percent availability of service. Flight service operations for inflight radio communications are a non-ATC function, so that the service availability is something less than 100 percent (not specified). The duty cycle of ATC communications is approximately 35 percent during the peak hour. The duty cycle for FSS communications has been estimated at 19 percent for a load of 100,000 radio contacts per year (Subsection 10.3.4 of this report). The FSS communications duty cycle was calculated for an FSS complex; i.e., an FSS plus its remoted radio outlets (e.g., LRCO, RCO, etc.). Thus, for a single radio outlet, the duty cycle is lower. These estimates are based upon voice communications.

A reduction in circuit miles may be accomplished by implementation of a network structure which introduces time sharing to: 1) En route secondary circuits, i.e., the redundant backup circuits, and 2) FSS primary circuits.

Since radio calls initiated by pilots must be received, the circuit time-sharing concept requires the use of concentrators that connect with all air/ground radio outlets on a full-period basis. The concentrator may then be employed to optimize the utilization of circuits between concentrator and Center (ARTCC).

Exhibit 12-5 illustrates the concept. Exhibit 12-5A shows a common star network with all facilities connected to the center. Exhibit 12-5B shows an arrangement of four concentrators distributed within the Center Area. It is evident that circuit mileage is minimized: 1) by obtaining a high n/k ratio and 2) by placing the concentrators at a maximum distance from the Center.

An application of this network structure to the Oakland-ZOA is shown in Exhibit 12-6. Three concentrators are placed at Red Bluff, Reno, and Fresno. These locations coincide with AF Sector Offices, as shown in Exhibit 12-7. In addition, the physical location of the concentrators may be placed at the Flight Service Stations at Red Bluff, Reno, and Fresno, since they would no longer be required as radio outlets (see Chapter 10). A fourth concentrator is located at the Oakland Center to accommodate those radio facilities that are adjacent to Oakland--also an AF Sector Office.

A number of advantages are associated with this arrangement:

- Circuit miles may be minimized by time sharing of the trunk circuits between the concentrators and Oakland.
- Air Traffic Controllers and Flight Service Specialists may access any radio facility in the network.
- Maintenance is organized around the current Section Office locations.
- Redundant circuit ratios may be minimized on the trunk segment of the network.
- Radio access and control may be fully automated with the circuit switching structure provided by the network.
- A digitally controlled circuit switching network provides a potential for data transmission operations.
- Current facilities (i.e., FSSs) may be reconfigured to house the concentrators.
- Performance monitoring, test, and facility control may be placed at the concentrator locations.

AD-A042 514

VERVE RESEARCH CORP ROCKVILLE MD
STUDY REQUIREMENTS FOR AN INTEGRATED AIR/GROUND COMMUNICATIONS --ETC(U)
MAY 77 J HANSEN, A WEBSTER, B REYNOLDS

F/6 17/2.1

DOT-FA75 WAI-570

UNCLASSIFIED

VS-29

FAA-RD-76-154

NL

3 OF 4
AD
A042514



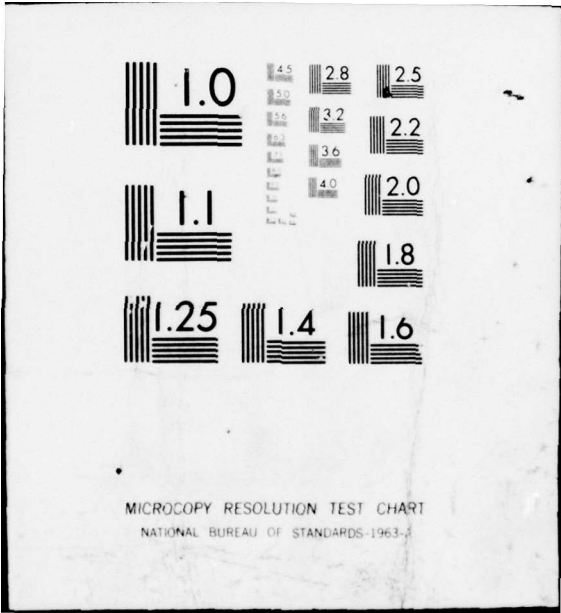
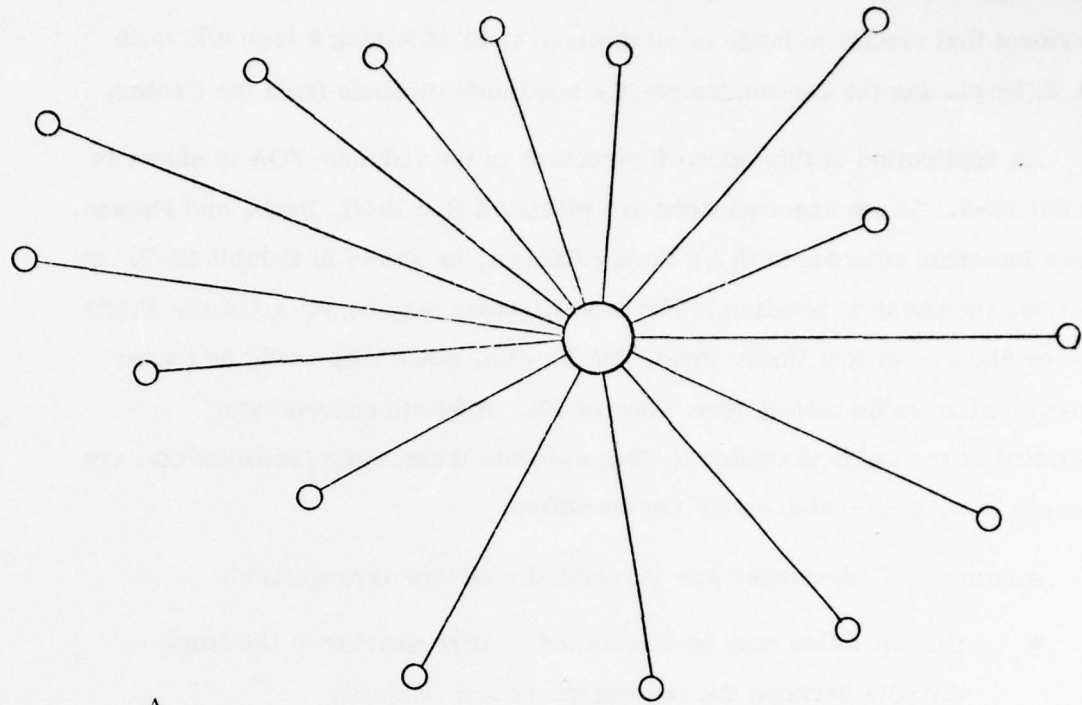
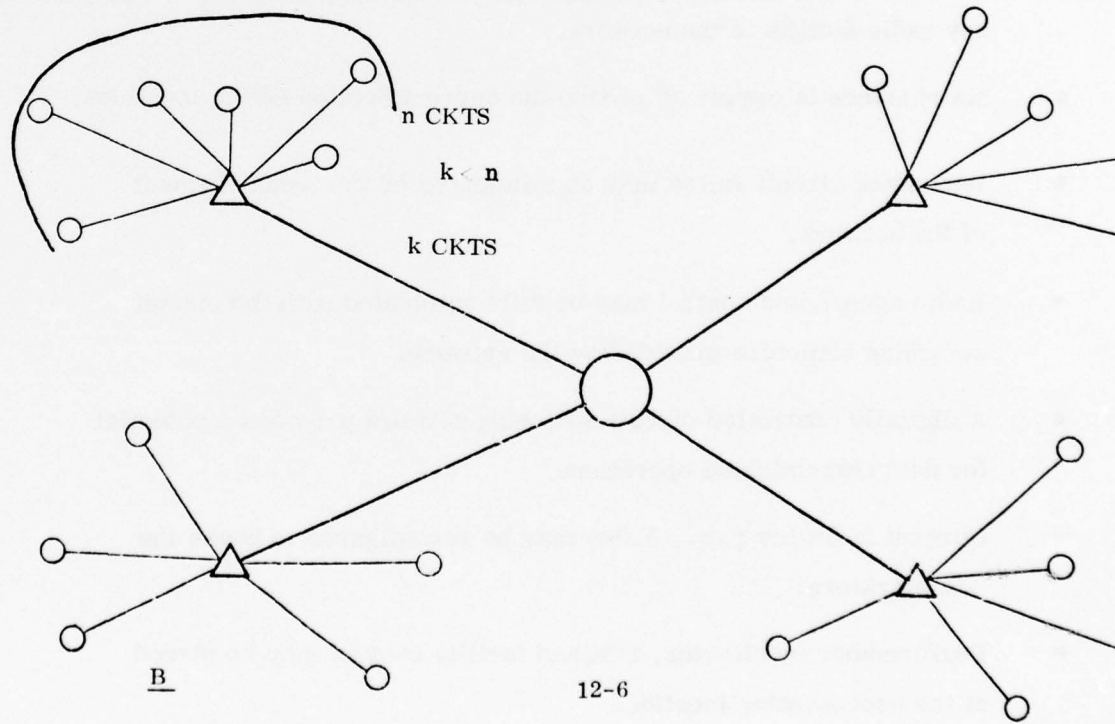

Exhibit 12-5: NETWORK CONCEPT FOR AIR/GROUND



A



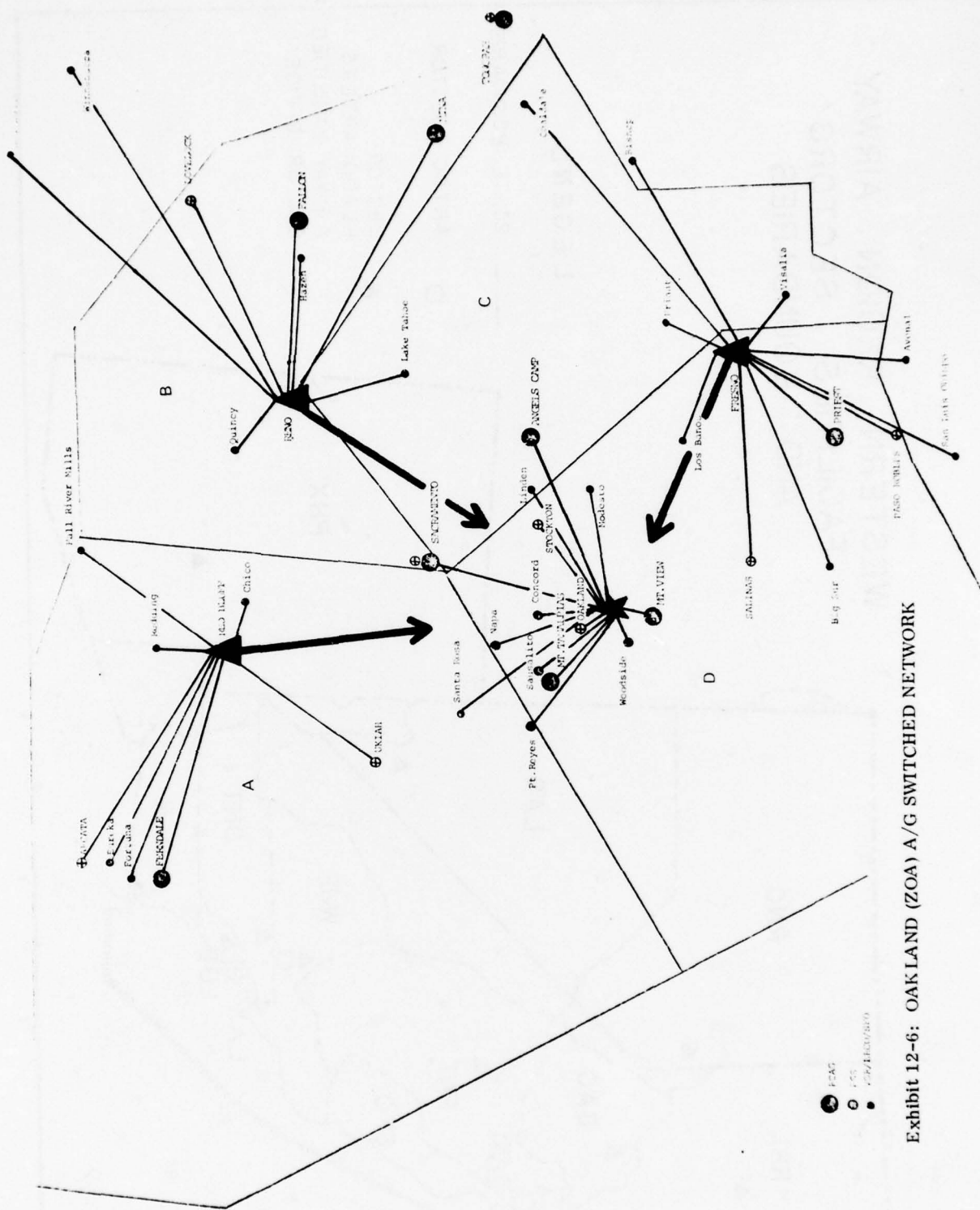
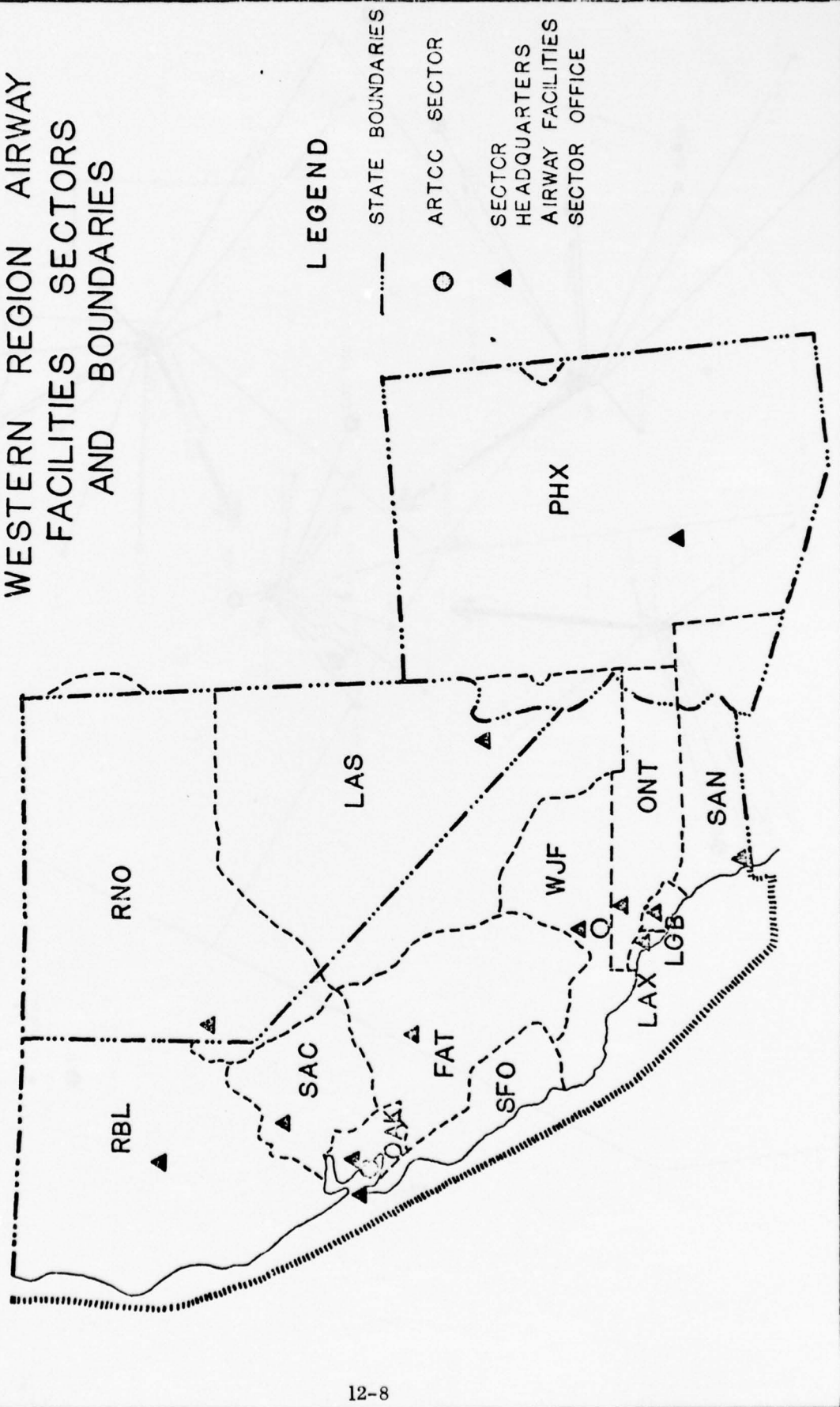

Exhibit 12-6: OAKLAND (ZOA) A/G SWITCHED NETWORK

Exhibit 12-7: AIRWAY FACILITIES SECTOR OFFICES

WESTERN REGION AIRWAY FACILITIES SECTORS AND BOUNDARIES



- Terminal Communications (TCOM) may access or be accessed via the Terminal-Center trunks.

12.3 RADIO ACCESS AND CONTROL

The radio access and control logic is based upon two guidelines:

- (1) The Air Traffic Controller at the control site (ECOM or TCOM) has full period (continuous) access to his assigned radio facility (sector frequency).
- (2) The Flight Service Specialist has a demand access capability to any of his assigned radio facilities.

For example, if a Flight Service Specialist exercises control over some number of radio facilities (e.g., 10 or 20), he may gain access by selection of any one facility with a minimal delay (e.g., less than 10 seconds).

A tentative sizing of the required radio access and control switch located at the ARTCC is obtained through the use of Exhibits 12-8 through 12-11. The concentration at each of the concentrators is estimated on the basis of the following:

- All primary ATC frequencies are normal through (i.e., one-to-one).
- The FSS circuits are concentrated in a 10:1 ratio to the largest integer.
- One emergency circuit is provided for each concentrator.
- Two backup (secondary) circuits for HAT and LAT are provided for each concentrator.
- Spare circuits for ATC operations are provided according to the redundancy ratios calculated in Chapter 11 of this report.

The radio access and control switch plus concentrators is shown in Exhibit 12-12. A rectangular, solid-state, common control, space-division switch with approximately (46 x 60) cross points is required. For required reliability, it is assumed that each position is redundant (i.e., dual positions) and that the switch and common control processor exhibit a reliability of 0.99998.

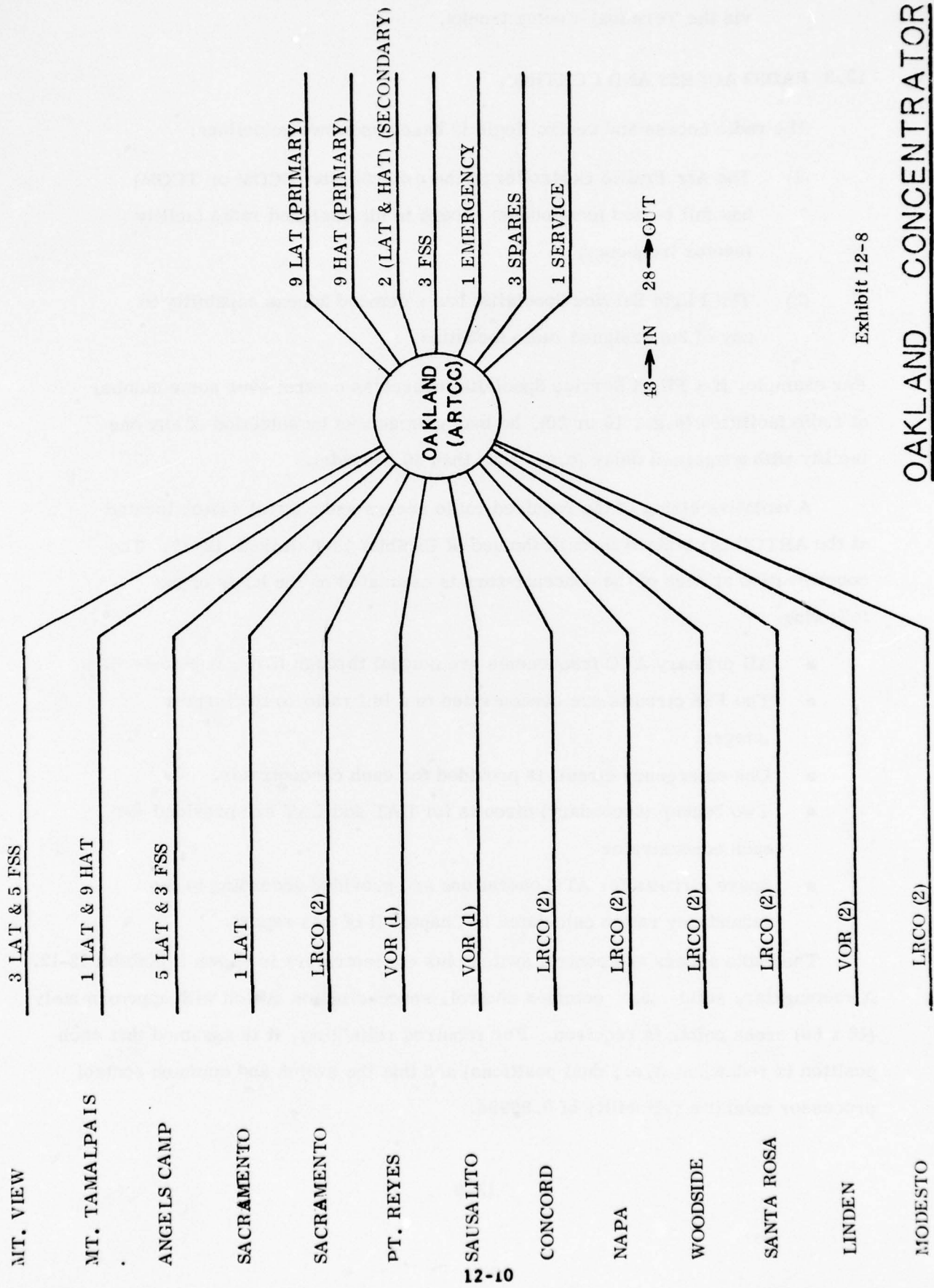

Exhibit 12-8

OAKLAND CONCENTRATOR

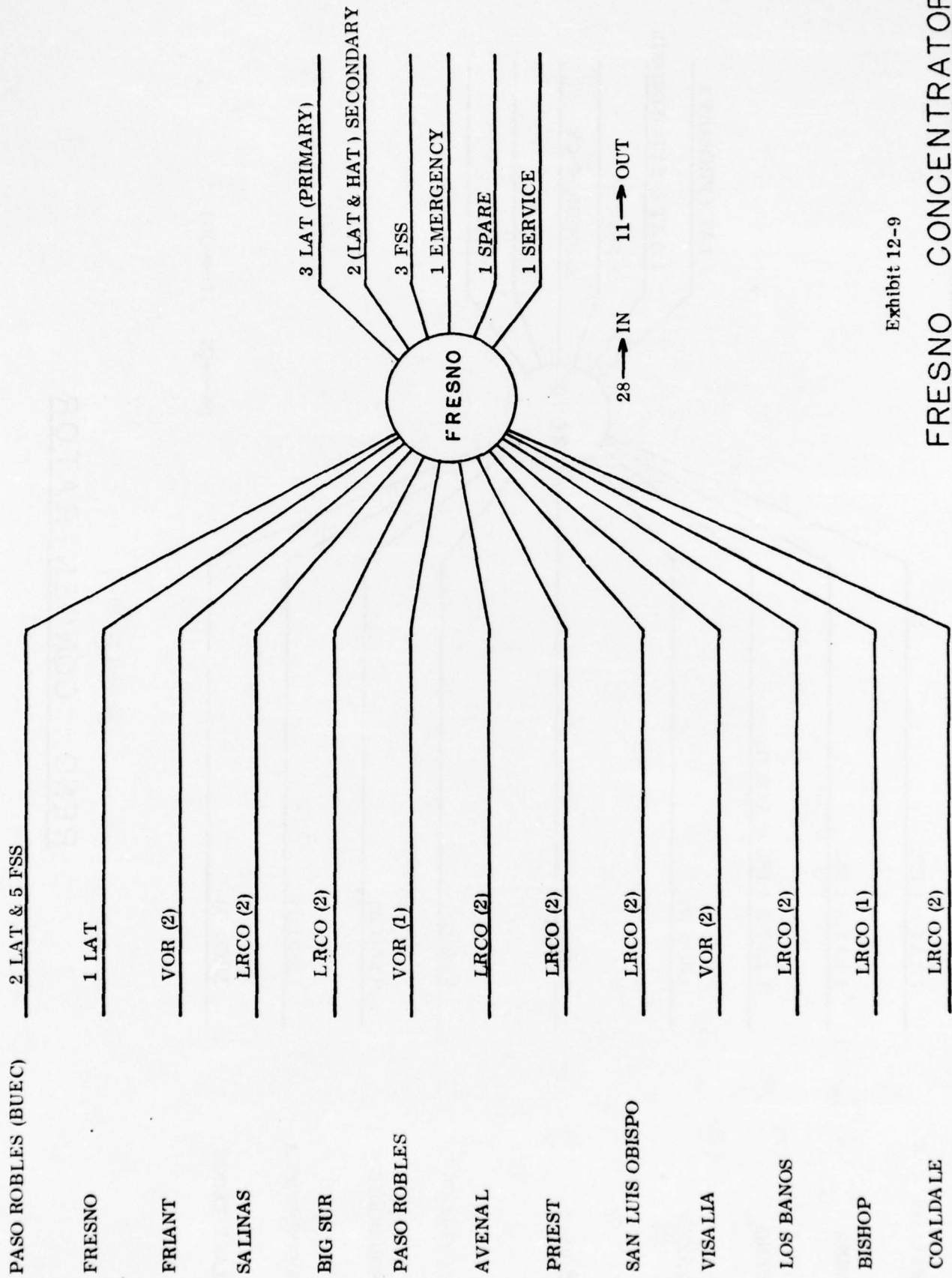
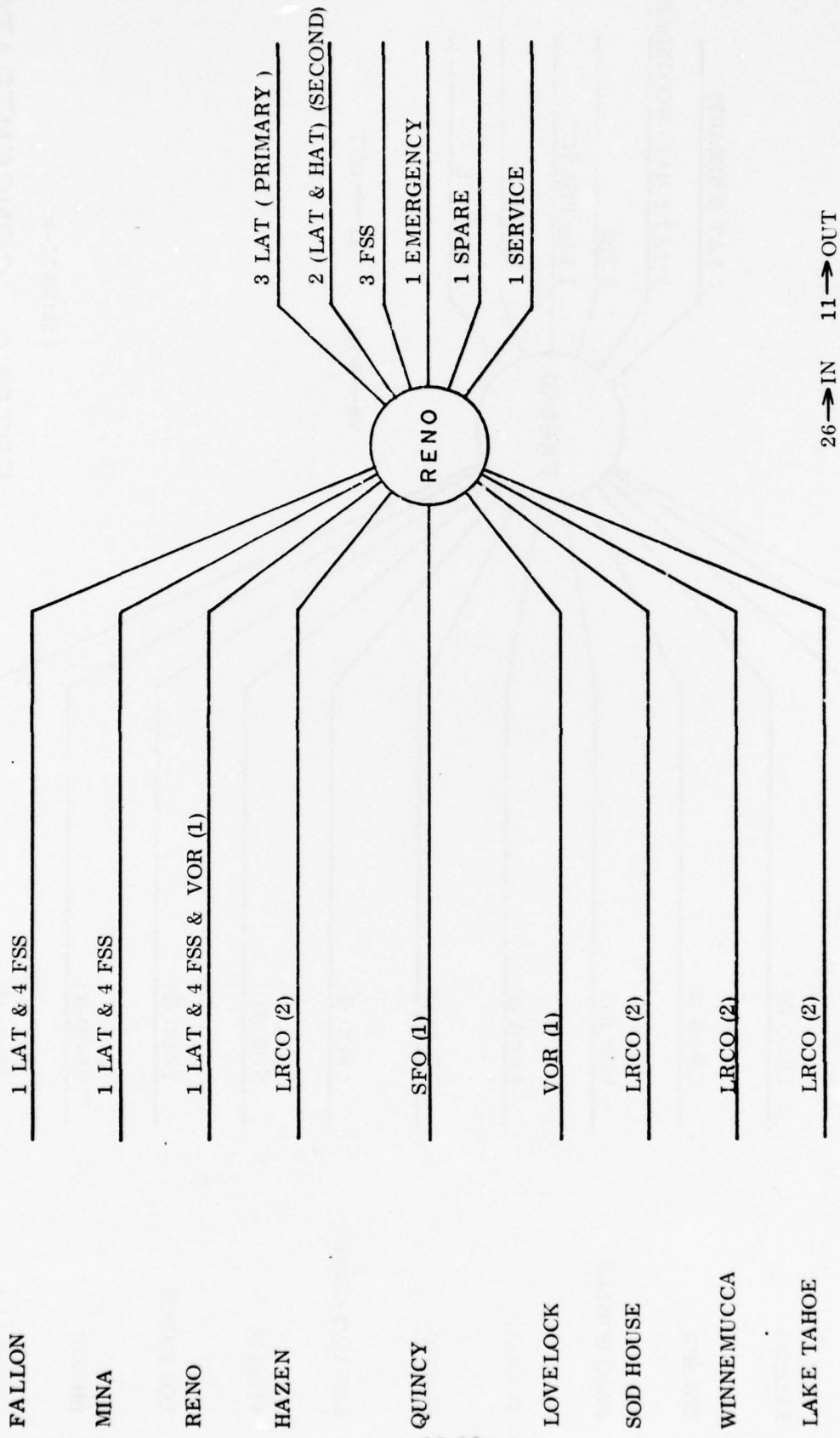
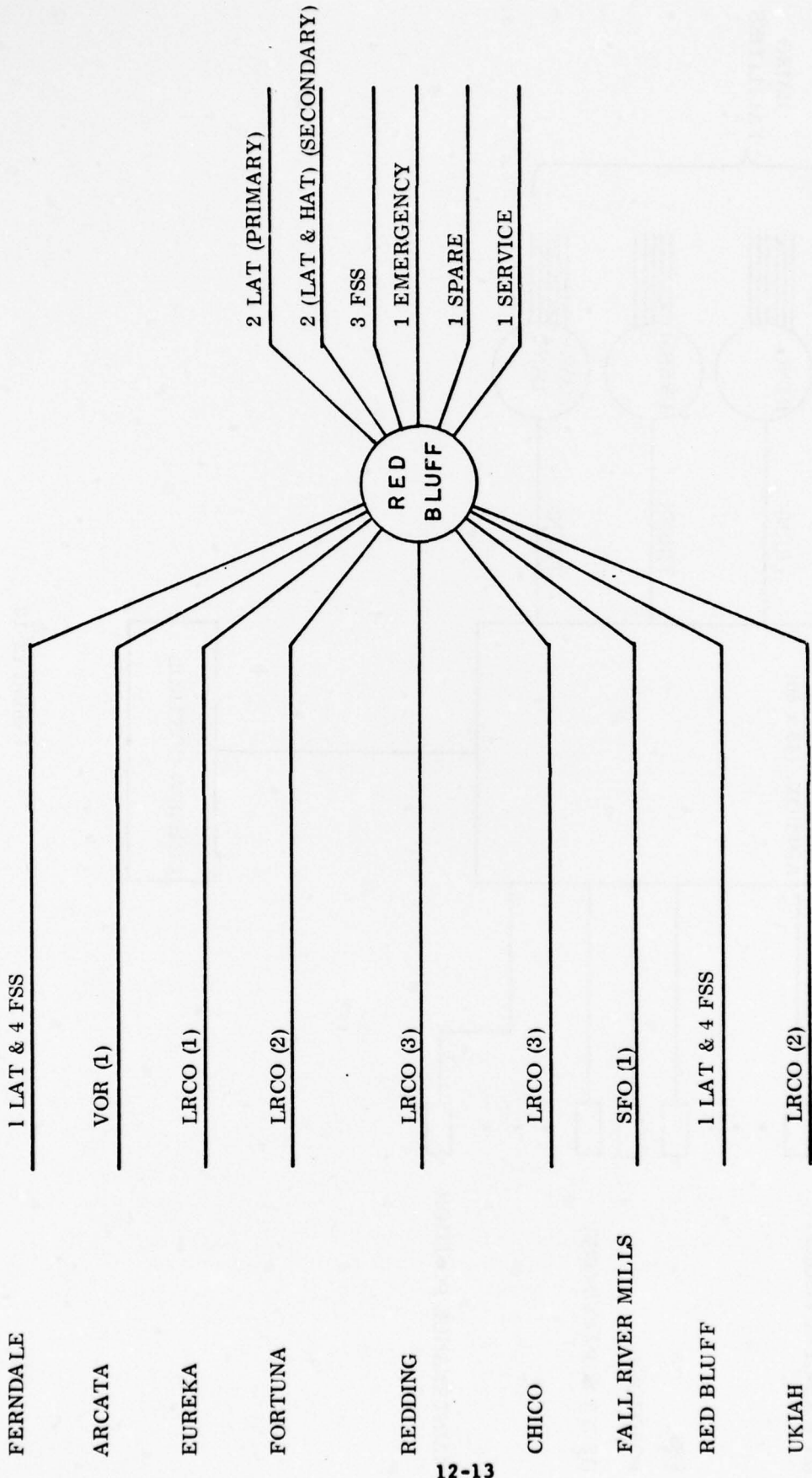

Exhibit 12-9

FRESNO CONCENTRATOR



RENO CONCENTRATOR



23 → IN 10 → OUT

Exhibit 12-11

RED BLUFF CONCENTRATOR

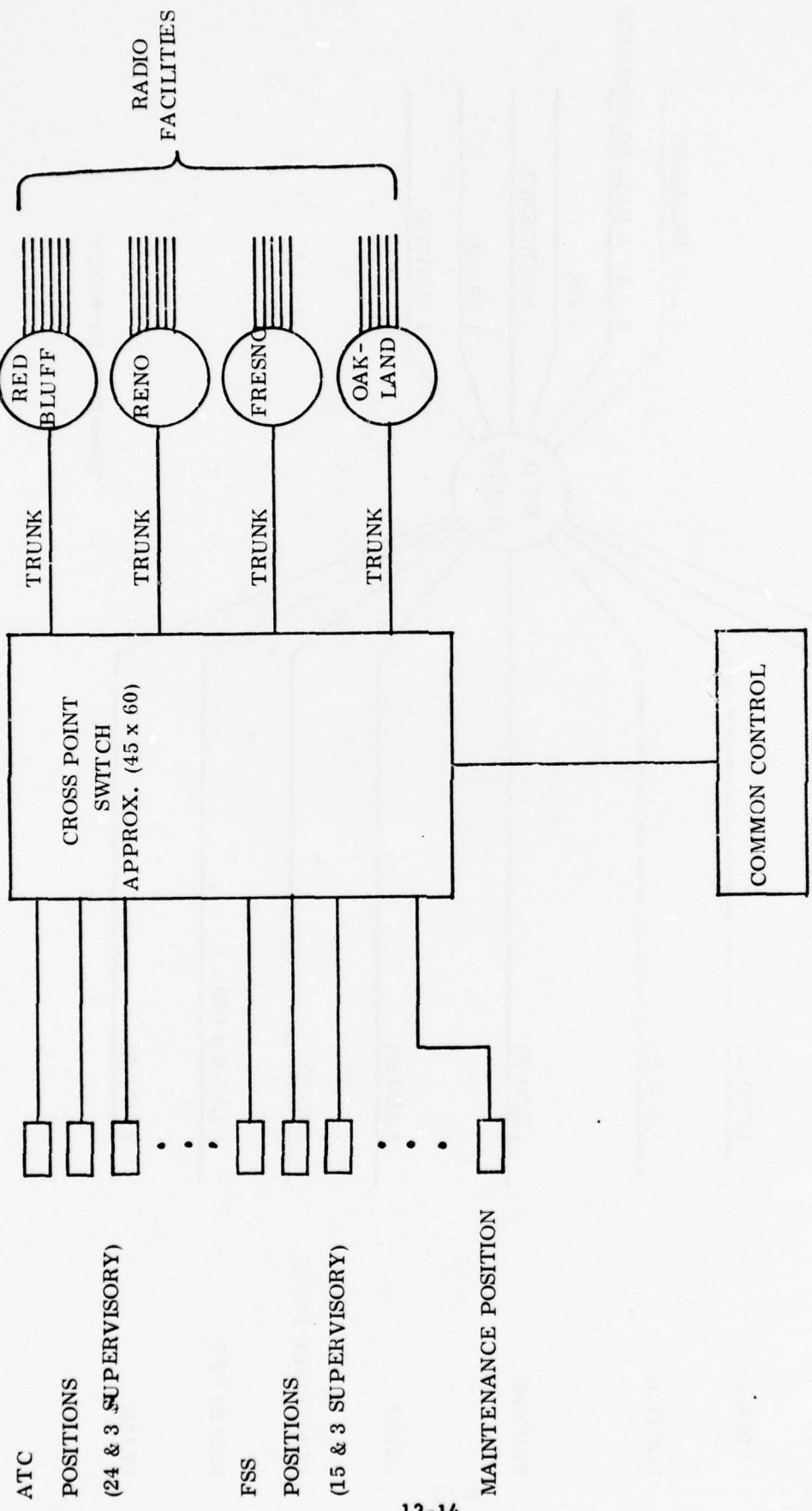

12-14

Exhibit 12-12

RADIO ACCESS AND CONTROL

12.4 ATC RADIO POSITION LOGIC

For discussion, it is necessary to distinguish among three potential modes of operation for air/ground radio access and control:

- (1) The current manual analog system.
- (2) A digitally controlled circuit switched network supporting voice radio operations.
- (3) A digitally controlled circuit switched network supporting both voice and digital communications for air/ground radio service.

Continuation of the current manual analog operation for air/ground voice radio is ineffective for several reasons. First, the direct remoting of all radio and NAVAID facilities to the Center, made necessary by the FSS Improvement Program, will be extremely costly in terms of leased circuits and FSS-Hub personnel. Second, the air/ground voice mode is not responsive to the requirements generated by several of the UTG Programs. Third, the concept of automated maintenance of air/ground telephone lines and radio facilities is not consistent with an analog mode of communications.

An intermediate approach is to digitally control the air/ground radio network in order to gain the cost-benefits of line sharing, real-time radio control and real-time automated maintenance. This approach applies digital techniques to access and control radio facilities and allows digital messages to be transmitted over the ground portion of the network.

The most advanced concept is to implement a digitally controlled network that provides capability for both voice and data transmission in support of air/ground communications. It will be evident that once the intermediate approach described above is selected as an option, then the addition of air/ground data transmission almost follows as a by-product.

The following description assumed an intermediate approach as defined in item (2) above and also discusses the options available with inclusion of air/ground data transmission. (Automated Air Traffic Control Operations are discussed more fully in Chapter 14).

The assumption of a digitally controlled network for ATC radio communications allows the incorporation of all radio access and control functions as digital messages utilizing the entire bandwidth of the remoting circuit, i. e., radio transmissions and the set of control functions are mutually exclusive, so there is no conflict.

The Air Traffic Controller may exercise the following access and control functions from the ATC position:

- Facility select
- Radio frequency select
- Alternate telephone line command
- Push to talk.

For normal operation, a position will always utilize the same facility and assigned radio frequency for sector coverage. For periods of sector combinations, a controller may select two facilities, thereby combining positions for low activity traffic.

If the primary facility normally used does not provide satisfactory service (a subjective judgment), the controller may select the appropriate alternate facility (see Chapter 10). The controller also retains the option of changing telephone lines, radio equipments, or both--all associated with the primary or secondary facility.

A CODEC/MODEM unit set in an on-line position is associated with each outgoing line from the position. The control signals listed above are digitally encoded and transmitted to the appropriate facility. A coded word of 15 bits (11 information bits and 4 check bits) will provide 2,048 words (see Chapter 14).

At a 2,400 bps data rate, each word will occupy 6.25 ms. The control transmissions of coded words will operate in an error detection and feedback mode, i. e., words detected in error at the facility will generate a request for a repeated transmission (RQ). All messages will be authenticated and acknowledged (e. g., the controller position will receive an indication that the transmitter is keyed).

Since "stuck on" transmitters are to be avoided, a fail-safe system protecting against cable cuts will unkey the transmitter if no modulation is present within a sampled period. The modulation sensor and processing employed at the facility for automated maintenance (see Chapter 13) will be employed for the fail-safe function.

For incoming radio transmissions, the signals are directly routed to the controller position. The MODEM/MODEM unit of the remote facility is only switched on line for acknowledgements (ACK) and requests for repeat (RQ). Exhibit 12-13 illustrates the configuration for one position.

There is no line sharing for ATC operations. Instead, each position is assigned a dedicated (full period) remoting communications service. The number of spared lines available will be adequate to assure 100 percent service availability.

The advantage of digital control is evident in the elimination of all of the tone equipment, filters, and line slots that are required for voice/tone multiplex. The solid-state logic and switching will eliminate the mechanical stepping switches and relays that are currently used.

The Radio Access and Control System will interface with all ATC positions and perform, under program control, the logical instructions for selection, switching, position display generation, and local maintenance interface.

A controller radio position is shown in Exhibit 12-14. The input/output is performed with an interactive keyboard and display, for maximum flexibility and ease of operation. The controller enters the site selection code which connects the position to a specific facility. The frequency select code selects a primary (fixed tuned) radio equipment at the facility. The alternate line command selects a spare circuit and flags maintenance attention to the rejected primary line. The alternate radio equipment command tunes a spare transceiver at the selected site (i. e., primary or alternate) to the assigned frequency. Each action is acknowledged and displayed on the window display. The PTT function is confirmed by a transmitter "on" indication on the display.

Exhibit 12-13

CONTROLLER POSITION CONFIGURATION

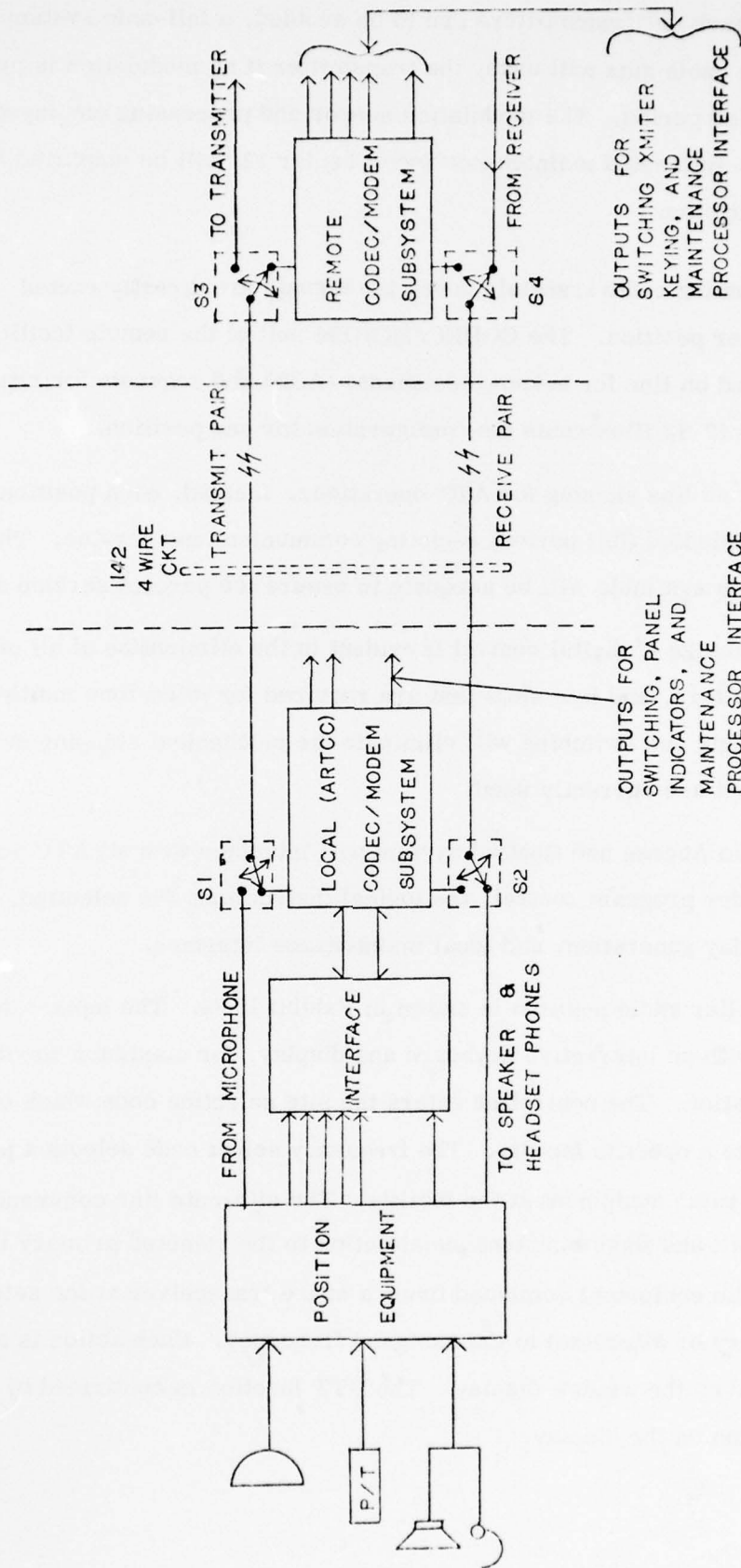

CONTROLLER DUAL POSITION CONFIGURATION

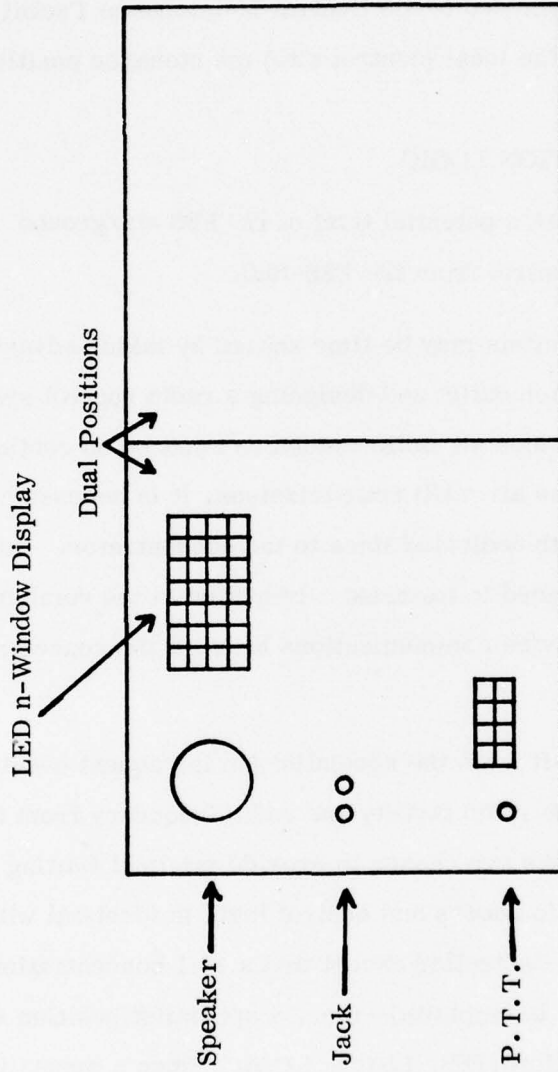

Interactive Keyboard

- Site Select
- Frequency Select
- Alt. Line Command
- Alt. Radio Eq. Command
- Interphone

Display

- Facility Designator
- Radio Frequency
- Tx. On
- Channel Busy
- RQ
- A/C Call in with ID and Facility

FSS Only

The controller position interfaces with the ARTCC maintenance console through the local radio access and control processor. Each change in configuration of lines, radio equipments or radio facilities initiated by the controller is intercepted at the maintenance position. The line or radio equipment rejected by the controller is automatically tested for performance by the remote facility processor and the results transmitted to the Central Maintenance Facility, the Maintenance Sector Office and the local (control site) maintenance position.

12.5 FSS-HUB RADIO POSITION LOGIC

As noted above, for ZOA a potential total of 177 FSS air/ground outlets exists that require control from the FSS-Hub.

This large number of outlets may be time shared by taking advantage of the expected duty cycle for each outlet and designing a radio control system that provides adequate service. Since all radio receivers must be on continuous standby for incoming (from the aircraft) transmissions, it is necessary to connect the FSS receivers with dedicated lines to the concentrator. However, the concentrator may be designed to exercise a reduction in the number of trunks assigned for flight service communications between the concentrator location and the FSS-Hub.

Outgoing calls to aircraft from the specialist (an infrequent event) are easily handled by selecting the radio facility and radio frequency from the specialist position. The number of trunks are chosen to provide minimal waiting time for call completion. The radio access and control logic is identical with that described for the Air Traffic Controller, except that a 10:1 concentration ratio of trunks to FSS radio outlets is employed--i.e., a specialist position will assume responsibility for up to 10 outlets (FSS, LRCO, RCO). Since a specialist can communicate with only one aircraft at a time, no outgoing blocking will occur.

Incoming radio calls require call detection in order to automatically set up the required signaling path from the radio receiver to the FSS-Hub. This can be accomplished with the provision of selective calling units which preface each desired transmission with a short code that requests air/ground service.

The pilot activates his unique call code, which identifies the aircraft. The radio facility receives the call code and normals it through to the concentrator, where it is placed on an available trunk to the FSS-Hub. The line concentrator adds the facility identification to the code before relaying to the FSS-Hub. At the specialist position, an interactive display reads out the request for service, identifying both the aircraft calling and the remote radio facility. The four-wire (transmit and receive) path has been automatically completed, so the specialist answers the call over the assigned trunk. The decoding and processing capability of the digitally controlled, switched network can handle the logical operations involved. Aircraft using the service must be equipped with a selective calling device which interfaces directly with the input of the airborne radio transmitter. In quantity production, these devices are estimated to cost approximately \$50.00

It is useful to estimate the probable queueing times for radio service with the assumed 10:1 concentration of incoming lines.

12.6 ESTIMATED SERVICE TIMES

First, the effect of concentration on the access time to the radio system will be examined. A single-server queueing situation will serve as a reasonable model of the remote lines /trunk configuration. The model consists of n remote dedicated lines from outlying flight service radio equipment (e.g., VORs, LRCOs) concentrated at a switching center into a one-line trunk back to an FSS-Hub position. The intention is to find the largest number n that will result in an acceptable "waiting line" and acceptable waiting time. The arrival pattern of aircraft¹ to a given site is assumed to be a Poisson arrival pattern. Based on the number of radio contacts per FSS complex per year, this arrival pattern seems to be reasonable. The terms and formulas to be used are shown in Exhibits 12-15 and 12-16.

1. By "arrival of aircraft," the assumption is that a radio contact is desired and will be attempted.

Exhibit 12-15

THE NOTATION USED IN THIS SECTION

n	Number of arrivals per hour
$E(n)$	Average number of arrivals per hour
t_s	Service time for an aircraft contact
$E(t_s)$	Mean service time for all aircraft contacts
ρ	Facility utilization of one serving facility
t_w	Time an aircraft spends waiting for service (not including aircraft being served)
$E(t_w)$	Mean of t_w for all aircraft
w	Number of aircraft waiting for service (not including aircraft being served)
$E(w)$	Mean of w for all aircraft
t_q	Time an aircraft spends in system, waiting and being served
$E(t_q)$	Mean of t_q for all aircraft
q	Number of aircraft in system, waiting and being served
$E(q)$	Mean of q for all aircraft
$E(t_d)$	The mean waiting time for aircraft which have to wait (not including aircraft with waiting time = 0)
$P(q = N)$	Probability that N aircraft are in the system
$P(q \geq N)$	Probability that q equals or is greater than integer N
$E(x)$	The mean value of x
$E(x^2)$	The second moment of x
$E(x^3)$	The third moment of x
σ_x	The standard deviation of x

Source: Martin, Systems Analysis for Data Transmission, Prentice-Hall, 1972.

Exhibit 12-16

FORMULAS FOR SINGLE-SERVER QUEUES

- Assumptions:
1. Poisson arrival pattern
 2. Dispatching discipline does not give preference to aircraft with shorter service times
 3. Formulas for second moment and standard deviation of queue sizes, or times, assume first-in, first-out dispatching
 4. No aircraft leave the queue

$$\rho = E(n)E(t_s)$$

$$t_q = t_w + t_s$$

$$E(t_q) = E(t_w) + E(t_s)$$

$$E(w) = E(n)E(t_w)$$

$$E(q) = E(n)E(t_q)$$

$$E(w) = \frac{\rho^2}{2(1-\rho)} \left[1 + \left(\frac{\sigma t_s}{E(t_s)} \right)^2 \right]$$

$$E(q) = \rho + \frac{\rho E(t_s)}{2(1-\rho)} \left[1 + \left(\frac{\sigma t_s}{E(t_s)} \right)^2 \right]$$

$$E(t_w) = \frac{\rho E(t_s)}{2(1-\rho)} \left[1 + \left(\frac{\sigma t_s}{E(t_s)} \right)^2 \right]$$

$$E(t_q) = E(t_s) + \frac{\rho E(t_s)}{2(1-\rho)} \left[1 + \left(\frac{\sigma t_s}{E(t_s)} \right)^2 \right]$$

FORMULAS FOR SINGLE-SERVER QUEUES

$$E(t_w^2) = \frac{E(n)E(t_s^2)}{3(1-\rho)} + \frac{E^2(n)E^2(t_s^2)}{2(1-\rho)^2}$$

$$\sigma_{t_w} = \sqrt{E(t_w^2) - E^2(t_w)}$$

$$= \sqrt{\frac{E(n)E(t_s^3)}{3(1-\rho)} - \frac{E^2(n)E^2(t_s^2)}{2(1-\rho)^2}}$$

$$E(t_q^2) = \frac{E(n)E(t_s^3) + 3E(t_s^2)}{3(1-\rho)} + \frac{E^2(n)E^2(t_s^2)}{2(1-\rho)^2}$$

$$\sigma_{t_q} = \sqrt{E(t_q^2) - E^2(t_q)}$$

$$= \sqrt{\frac{E(n)E(t_s^3)}{3(1-\rho)} - \frac{E^2(n)E^2(t_s^2)}{2(1-\rho)^2} + \sigma_{t_s}^2}$$

$$\sigma_q = \sqrt{\frac{E^3(n)E(t_s^3)}{3(1-\rho)} - \frac{E^4(n)E^2(t_s^2)}{4(1-\rho)^2} - \frac{E^2(n)(3-2\rho)E(t_s^2)}{2(1-\rho)} + \rho(1-\rho)}$$

Source: Martin, Systems Analysis for Data Transmission, Prentice-Hall, 1972.

The first parameter necessary for the calculation is an estimate of the mean number of radio contacts per FSS facility per hour. Assume an FSS complex having four remoted facilities and 100,000 annual radio contacts. If a uniform distribution of these radio contacts is assumed over a 12-hour period daily, seven days per week, then the estimate of the mean is about 6 (= 5.79) radio contacts per facility per hour.

The next parameters, the mean length of the radio contact, $E(t_s)$, and its standard deviation, σ_{ts} , are assumed to be 20 seconds¹ and 10 seconds ($0.5 E_{(ts)}$), respectively. With these three values, the main variable of the queueing model, the utilization factor, ρ , can be determined from

$$\rho = \frac{6 \times \text{\#VOR} \times 20}{3600}$$

where 3,600 is one hour in seconds. Utilizing this parameter and the appropriate formulas in Exhibit 12-15, we obtain the results tabulated in Exhibit 12-17. This table shows that a practical choice of the concentration ratio is about 10:1, with a negligible waiting line length and a mean waiting time of 6.21 seconds. To put these results in proper perspective, however, note that, based on the average arrival parameter ($E(n) = 6/3600$), the possibility exists that an aircraft may arrive and find no waiting line, and thus be served immediately. On the other hand, another aircraft may arrive slightly afterwards, and as a consequence have to wait about 20 seconds for service. This means that some aircraft (encountering a waiting line) will be delayed longer than the mean waiting time. For the single server case, the mean time of this delay, ($E_{(td)}$), is

$$E(t_d) = \frac{E(tw)}{\rho}$$

With a concentration ratio of 10:1 ($\rho = 0.33$), this number becomes $E(t_d) = 18.82$ seconds.

1. The switching and processing time is assumed to be much shorter than $E(t_s)$ and as such is neglected here.

Exhibit 12-17

QUEUEING RESULTS

$$\rho = \frac{6 \times \# \text{ of VOR} \times 20}{3600}$$

<u># of VOR</u>	<u>ρ</u>	<u>E(q)</u>	<u>E(w)</u>	<u>E(t_q) (sec)</u>	<u>E(t_w) (sec)</u>
8	0.27	0.33	0.06	24.66	4.66
10	0.33	0.43	0.1	26.21	6.21
12	0.4	0.57	0.17	28.4	8.40
14	0.47	0.73	0.26	31.17	11.17

The final result of the 10:1 line concentration is that an aircraft has a 67 percent chance of being served immediately (based on ρ) in any given hour (over the 12-hour period) and a 33 percent chance of encountering an average delay of about 19 seconds before being served.

Finally, based on the same queueing model, the probability that more than a given number, N , of aircraft will be waiting for service can be calculated. The equation for this event (with a worst-case standard deviation ($\sigma_{t_s} = E(t_s)$) is

$$P(q \geq N) = 1 - P(q \leq N)$$

where $P(q \leq N) = \sum_{i=0}^N (1-\rho) \rho^i$.

For the cases of 3 and 5 aircraft in the service line, the equation yields $P(q \geq 3) = 0.0133$ and $P(q \geq 5) = 1.29 \times 10^{-3}$.

The analysis is based upon consideration of routine flight service communications. Incoming emergency calls preempt all other communications and are handled in real time. The occurrence of emergency communications was considered as an infrequent event and therefore did not enter the queueing analysis.

12.7 CALL PROCESSING

The basis of the call processing concept is a "selective" call feature. Each aircraft will contain a signaling device which, when activated, will transmit an identifier code which, in turn, will seize an idle circuit and provide the Flight Service Specialist with the identity of the aircraft. The identifier code and signalling device may be based on the selective call schemes utilized by the air carrier industry. Codes can be implemented on a regional, national, or hybrid (national and regional) basis, depending on the aircraft population and on the code structure. A multitone frequency or simple digital techniques provides practical implementation schemes.

The circuit-seizing function will be accomplished on a "racetrack" (or equivalent) mode. This means that if an aircraft is within range of more than one FSS facility, the facility nearest (in terms of circuit mileage) to the concentrator will be the site utilized for communication. Radio receivers are expected to employ squelch levels so that any signal which breaks squelch will provide adequate intelligibility.

The switching logic is handled at the concentrator. Incoming circuits from a radio facility are terminated by a decode and switch module. This unit decodes the incoming message and places the code in a buffer. If a trunk is available, the controller places the code in the corresponding trunk buffer, switches the radio facility to the trunk and disables the decode and switch module. Then, the controller appends the facility ID onto the aircraft ID code and transmits all the information to the FSS-Hub position. The Flight Service Specialist thus knows who is calling and via which remote site. Since the link has already been set up, the specialist need only modulate the remote transmitter and answer the call. After the transaction is completed the specialist disables the connection between the facility and trunk. If no trunk is available, a busy message will be transmitted when attempts are made to contact the FSS. However, the aircraft ID code is put in a wait buffer for immediate trunk access as soon as a trunk becomes available.

12.8 SUMMARY

By introducing the concept of a digitally controlled switched network for air/ground radio service, it is possible to realize system performance improvement and to reduce the total circuit mileage used for remoting circuits. Since radio access, radio switching, and radio control are all under the control of a stored program, the configuration is extremely flexible in terms of modification. Thus each ARTCC and its associated concentrators may be adapted to the locally prevailing conditions of air activity and communications traffic. Particularly in the case of FSS communications, the number of serving trunks may be adjusted to realize any desired service response function. The analysis performed was illustrative in order to describe the concept, and does not fix any values for concentration ratios or for service waiting times.

13

AUTOMATED FACILITY MAINTENANCE

13.1 INTRODUCTION

In Exhibit 10-29 (Chapter 10) it was shown that, out of a five-site average recurring cost of \$32,375, expenditures for manpower totaled \$16,831. Manpower and lease-line costs together make up 7/8 of the total recurring costs.

The implementation of an automated maintenance service will result in a substantial reduction in the annual costs of maintaining air/ground radio facilities. Facility visits in order to provide routine maintenance, site certification, and service restoral average one or two per week. Minimizing facility visits by skilled technicians through automation appears to provide a feasible approach.

A reduction in frequency of visits from one per week to an average of one every three to six months would result in an increased maintenance productivity ratio of 12 to 24.

Air/ground radio facility maintenance can be divided into four primary categories:

- (1) Site certification
- (2) Failure isolation and service restoral
- (3) Equipment repair
- (4) Record keeping

Tradeoffs exist as to the degree of automation that is cost-effective. Site certification and equipment repair necessarily involve relatively more complex measurement and analysis procedures requiring the utilization of test instrumentation and diagnostic techniques.

The two areas where automated procedures may prove most effective are unscheduled maintenance (i. e. , failure isolation and service restoral) and record keeping. Unscheduled maintenance is relatively expensive due to its random occurrence. Record keeping is a highly repetitive and time-consuming task that is particularly adaptable to machine operations. Currently maintained reliability statistics lack completeness. This reinforces the advantage of implementing programmed, automated procedures.

Since the requirement is for continuous availability of service, the objective is to design a system that provides real time failure isolation and service restoral.

Assuming that automation is introduced, it is of interest to determine: 1) the location and configuration of the maintenance control facilities and 2) the characteristics of the on-site maintenance configuration. The following sections address these points.

13.2 MAINTENANCE NETWORK STRUCTURE

Maintenance for FAA operations is organized by Region, which may encompass one or more ARTCC Center areas of ATC operations. Exhibit 13-1 shows the Airway Facilities Sectors and Boundaries for the Western Region. The Oakland Center Area, within the Western Region, operates Maintenance Sector offices at Red Bluff (RBL), Reno (RNO), Sacramento (SAC), Oakland (OAK), San Francisco (SFO) and Fresno (FAT). The boundaries indicated in Exhibit 13-1 show the areas of maintenance responsibility for each Airways Facilities Sector Office.

Because of the travel involved to unattended facilities, the maintenance sector concept operates as a distributed network rather than a fully centralized operation. This concept is consistent with the discussion in Chapter 12 concerning network switching and control, which shows that the use of distributed network control is cost-effective in minimizing circuit mileage. In a similar sense, it is desirable to minimize travel time by also utilizing a distributed network for the control of maintenance activities.

Exhibit E-4: WESTERN REGION AIRWAY FACILITIES AND BOUNDARIES

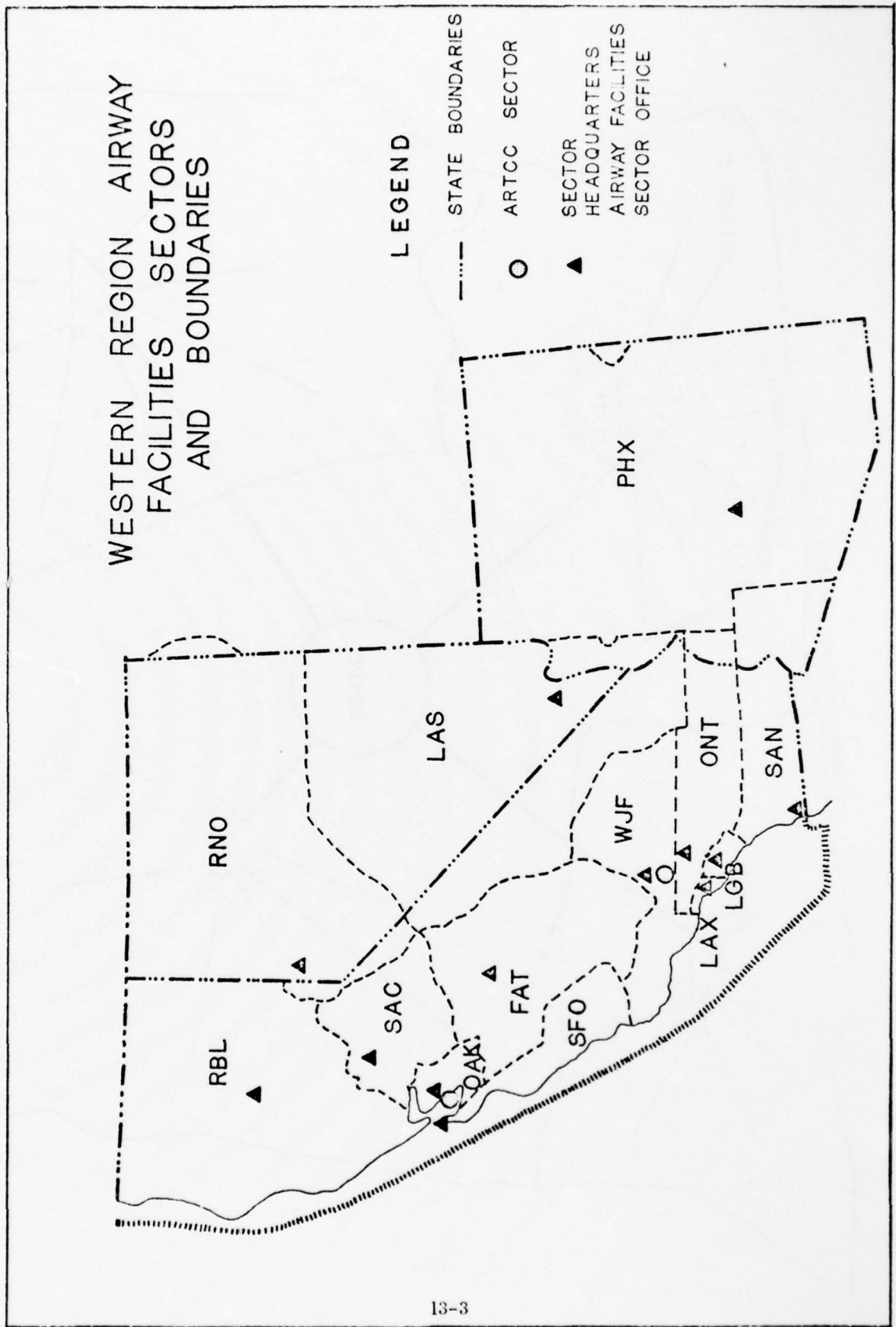
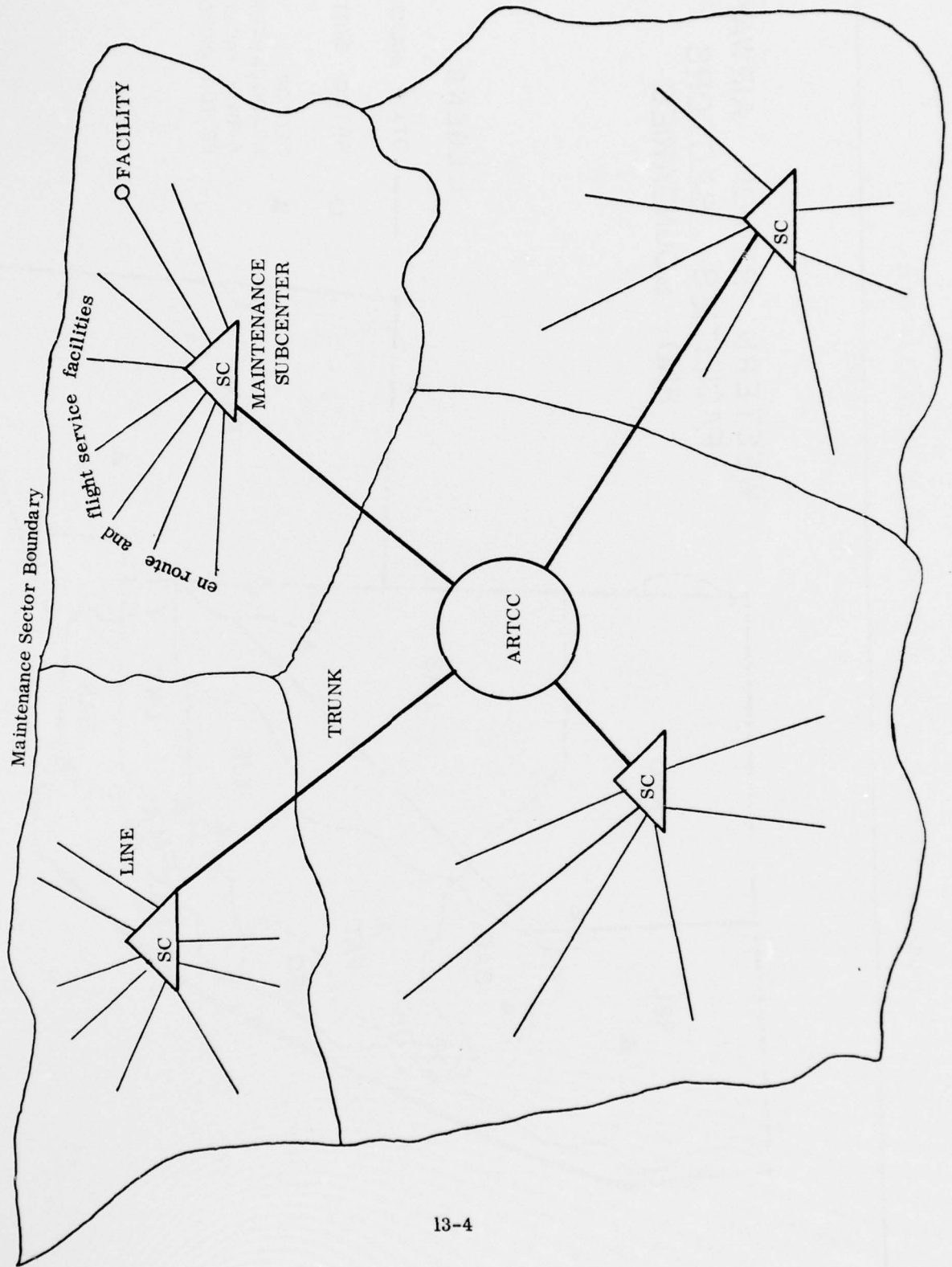

Exhibit 13-2: MAINTENANCE NETWORK CONCEPT



An additional factor of importance is the very substantial maintenance load that must be assumed for the formerly manned FSS network. It was shown in Chapter 10 that the complex of FSSs, RCOs, LRCOs and VORs must be controlled from the planned FSS-Hub at the ARTCC. The performance monitoring and control functions for these facilities must be reassigned.

Exhibit 13-2 illustrates a network concept in which all flight service and en route (radio and NAVAID) facilities are tied to distributed Maintenance Control Subcenters adjacent to Airways Facilities Sector Offices. The facilities within each maintenance sector area will be maintained by the appropriate Maintenance Control Subcenter. Each Subcenter is also tied to a centrally located maintenance console within the ARTCC. This arrangement satisfies the dual reporting requirements for operational personnel (AT) who require system status information and for maintenance personnel (AF) who require service failure information. It is assumed that facilities located in Terminal Areas will continue to be maintained by maintenance staff assigned to the ATCT/TRACON.

The concentrators described in Chapter 12 will serve to perform the required circuit-sharing and switching functions. Detailed performance monitoring data incoming from the facilities will be collected and processed at the concentrator locations. Thus, the concentrators described as part of the radio switching and control network for air/ground radio service will also function as an integral part of the maintenance service network. The supportive processing required at the concentrator locations will handle all logical switching as well as all maintenance data processing and display. Since the monitoring data normally share circuits utilized for air/ground operations, the data will be retrieved from the circuits at the Maintenance Subcenter location.

The resulting Maintenance Subcenter and Network Switching Facility will require staffing commensurate with the size and complexity of the operations.

As described above, the current FSS facilities located at Red Bluff, Reno, Fresno, and Oakland Center (ZOA) appear to provide feasible locations for the combined Maintenance Subcenter and Network Switching Facility. As was indicated in

Chapter 12, a service line was included between each concentrator and the ARTCC. The service lines are expected to handle intra-subcenter communications.

13.3 AIR/GROUND SYSTEM MAINTENANCE OPERATIONS

The primary function of air/ground radio facility maintenance is to assure continuously available service. The logical sequence of maintenance operations is as follows:

- (1) Fault detection and isolation
- (2) Service restoral
- (3) System element repair
- (4) Record keeping

The near 100 percent service availability requirements force the use of parallel redundant system elements as described in Chapter 11. With a parallel redundant system, it is feasible to perform operations (1) and (2) above in real time. Thus, the maintenance philosophy suggested by the availability requirement is one in which fault detection and isolation and service restoral are immediate objectives accomplished by an appropriate sensor system coupled with a service restoral switching system.

System element repair can be accomplished off-line within the average MTTR of 20 hours discussed in Chapter 11.

The incorporation of automated record keeping will provide historical data for system performance analysis and evaluation.

13.3.1 Fault Detection and Isolation

It is assumed that of the five system elements comprising an air/ground radio system, three are of major concern:

- Telco lines
- Radio facility
- Radio channel

Of the other two, the control site lies within the maintenance domain of the ARTCC or ATCT, and the aircraft radio is non-maintainable during flight operations.

For Telco Lines the performance criteria are related to voice intelligibility and to data transmission error. For the Radio Facility, faults which disrupt channel operations can occur in any of the following subsystems:

- Radio equipments and antenna system
- Power (commercial plus engine generator)
- Switching, control, and monitoring system
- Physical plant (Fire, Security, etc.)

For the Radio Channel, failure can be caused by an inadequate signal level or by excessive interference.

Considering the air/ground radio channel as a complete path between the control site and aircraft, it is evident that the most sensitive indication of performance is provided by the user. Because of the subjective quality of voice communications, an assessment of performance is best supplied by the controller/specialist. The addition of digital communications, particularly coded digital communications, provides a readily available method for evaluating air/ground channel performance. Since, as discussed in Chapter 14, it is suggested that an error detection and feedback system be utilized for data transmission, the quality of service may be related to the number of RQs (requests for retransmission).

Since the specifications for data communications are more stringent than for analog voice communications, it may be assumed that satisfactory data communications implies a satisfactory voice response. If a regenerative repeater is placed at the remote air/ground facility, then an effective isolation of failure between Telco line and radio facility is possible.

Therefore, in terms of fault detection and isolation for air/ground radio channel operations, it appears feasible to switch in alternate spare capability on the basis of 1) controller option for voice operations and 2) excessive word error rate for data communications.

The controller, as described in Chapter 12, has a number of options available:

- Primary (facility, line, radio equipment)
- Spare line to primary facility
- Spare radio equipment at primary facility
- Secondary facility

He may exercise any of the above options in order to restore service as a result of channel inoperability detected as a subjective evaluation.

Since radio service is provided by a digitally controlled network with circuit switching, and includes a capability for coded digital transmissions, a more accurate and objective assessment of service is possible. Assuming an implementation of data communications capability as an integral part of the air/ground system, then channel fault detection and isolation can occur on-line. Code words with bit errors are detected in transmission and a request for repeat initiated. Decoding words at the remote facility and re-encoding for transmission over the radio channel is equivalent to regeneration (noise cleaning) and also serves to isolate faults between the telephone line and the radio channel. An excessive number of RQs occurring in either segment of the air/ground channel path will cause a switch to the appropriate redundant element (i. e. , a spare line or spare radio equipment).

The detection of failure, the isolation of failure to the Telco circuit and the switching in of a spare circuit complete the maintenance operation for FAA. Circuit repair becomes the responsibility of the telephone company upon notification. The detection of failure and isolation to a point beyond the Telco line involves consideration of the radio equipment at the remote facility, the radio propagation channel, and the aircraft radio. Switching in a redundant radio equipment verifies radio failure. Switching to a secondary facility minimizes the probability that the failure is due to the radio propagation channel. This leaves the aircraft radio as the potential failed element. Successful communication with a second aircraft in the sector present a high probability that the first aircraft has radio equipment problems. For voice operations, this sequence is performed by the controller/specialist. For data link operations the sequence is automated through a series of logical decision and switching operations based upon detected word error rates (i. e. , RQs).

Within this overall framework of maintenance operations, the status and performance of the radio facility must be evaluated. Since radio equipments are thrown off line by either the controller or by automatic rejection by the data transmission system, it appears effective to limit radio equipment performance evaluation to off-line operations. That is, the radios placed in off-line status will be tested for adequate performance levels. The off-line testing of radios can be performed on a non-interfering basis, which avoids placing any test elements in series with other elements of an operational air/ground radio channel.

The power and physical plant monitors are static sensors that indicate out-of-tolerance conditions with simple closures that are transmitted to the maintenance consoles at the Maintenance Subcenter and the control site.

13.3.2 Service Restoral

As described in the preceding paragraphs service restoral is accomplished in real time by switching in redundant elements as required. Service restoral is controlled either by the controller/specialist or automatically by preprogrammed logic.

13.3.3 System Element Repair

Repair procedures for radio facilities have been estimated to average 20 hours (MTTR). The MTTR for solid-state radio equipments is 15 minutes (specification) and involves printed circuit card replacement. Unrepairable radios are removed and replaced with equipments from the supply depot. The turnaround time for depot replacement can be as short as 24 hours assuming a priority request from the Region. Holding a few transceivers as floating spares would enable a Region to replace unrepairable radios well within the 20 hour MTTR. The telephone line repair time (service restoral) and the commercial power MTTR are well within the 20 hour MTTR.

The switching, control, and monitoring (SCM) subsystem of the radio facility will comprise a dual microprocessor unit with required peripheral devices. The

subsystem will be comprised of modular printed circuit cards, so that an estimated MTTR of 15 minutes appears reasonable.

13.3.4 Record Keeping

Automated record keeping supported by algorithms for generating periodic summaries of performance will add a powerful and cost-effective means for evaluating system availability and system element reliability.

Failure data will be accumulated and sorted at the Maintenance Subcenter. Excessive failure rates for any given system element will be flagged for appropriate action by AF staff. The record keeping serves as a means for service availability verification of specified performance and also serves as a diagnostic aid to isolating chronic system element deficiencies. Accumulation of data describing radio coverage gaps may be accomplished by controller/specialist insertion of aircraft position (retrieved from NAS/ARTS storage) whenever radio propagation channel failures occur.

13.4 SITE MAINTENANCE CONFIGURATION

Exhibit 13-3 shows a configuration of equipment subgroups comprising the elements monitored at an air/ground radio facility. Following an approach that minimizes the monitoring complexity appeared to be most effective. The monitored parameters indicated in Exhibit 13-3 are addressed to the real time determination of failure presence and isolation.

Initially, the intent was to perform a complete test and evaluation cycle equivalent to site certification procedures. This approach was rejected for two reasons:

- (1) The degree of required instrumentation and processing complexity appeared excessive.

Exhibit 13-3

RADIO FACILITY PERFORMANCE MONITORING

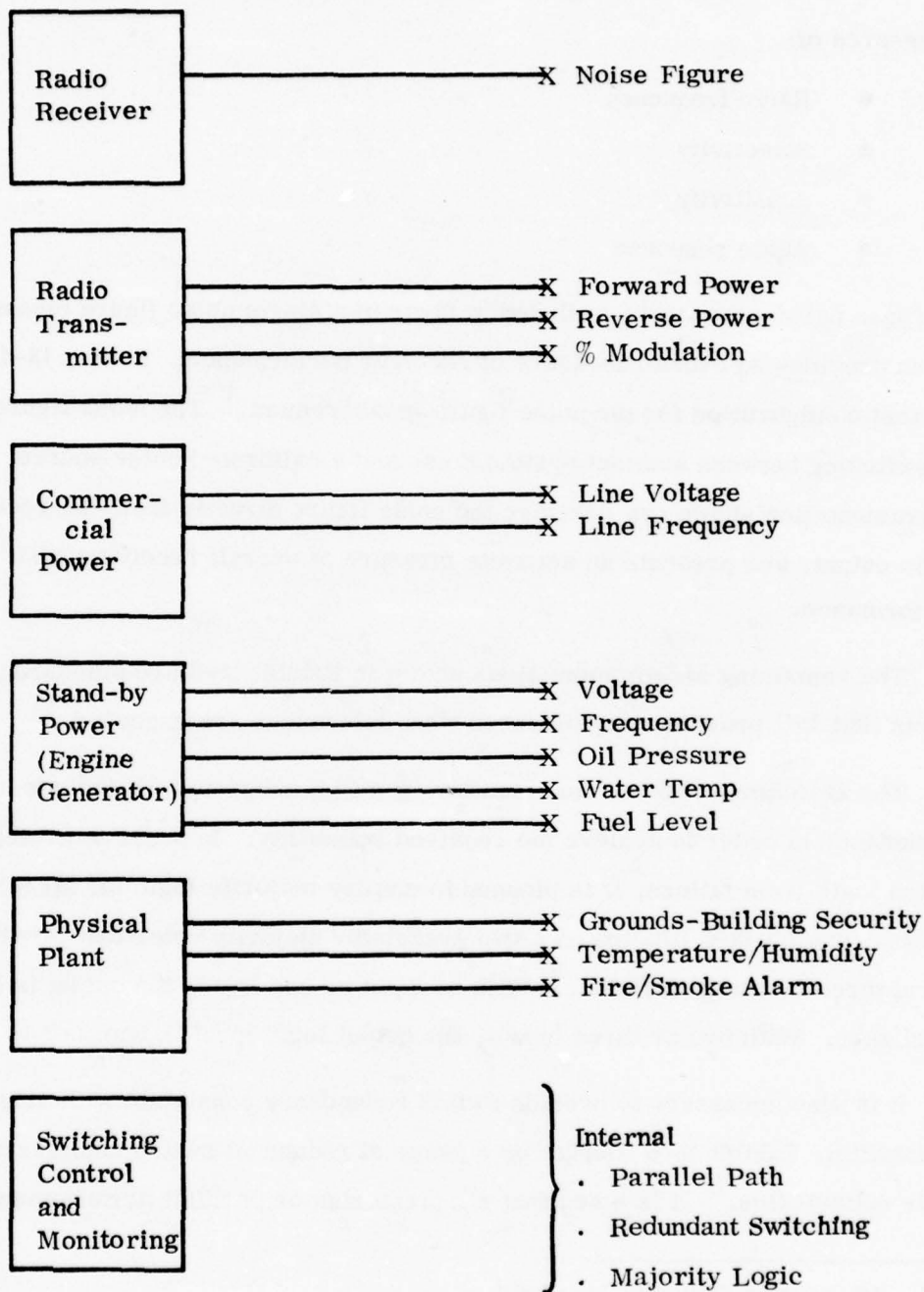

- (2) The expectation of infrequent site visits (e.g., one every three to six months) in order to perform routine maintenance functions requiring a variety of test instrumentation.

As an example, the original test for radio receiver performance included measures of:

- Radio frequency
- Selectivity
- Sensitivity
- Audio response

These parameters were excluded in favor of a single noise figure measurement which provides an overall measure of receiver performance. Exhibit 13-4 shows the test configuration for the noise figure measurement.¹ The noise figure is obtained by switching between ambient system noise and a calibrated noise source. The instrumentation shown can measure the noise figure directly from the receiver's audio output, and presents an accurate measure of overall receiving system performance.

The remaining sensor indications shown in Exhibit 13-3 are standard measurements that will provide relay closures when tolerances are exceeded.

The switching, control, and monitoring (SCM) subgroup will include internal redundancy in order to achieve the required reliability. In order to protect the decision logic from failure, it is planned to employ majority logic for all SCM decision points. Exhibit 13-5 illustrates a two-transistor majority voter that provides a two out of three majority decision.² With no input or one input, the output is logic level zero. With two or three inputs, the output logic level is one.

It is also necessary to provide switch redundancy consistent with single-switch reliability. Exhibit 13-6 illustrates a group of redundant switch configurations and their reliabilities.³ It is noted that simple series or parallel arrangements do not

1. Microwave Journal, May 1976.

2. "Probabilistic Reliability," Shooman, McGraw-Hill, 1968.

3. Ibid.

Exhibit 13-4: RECEIVING SYSTEM NOISE FIGURE MEASUREMENT

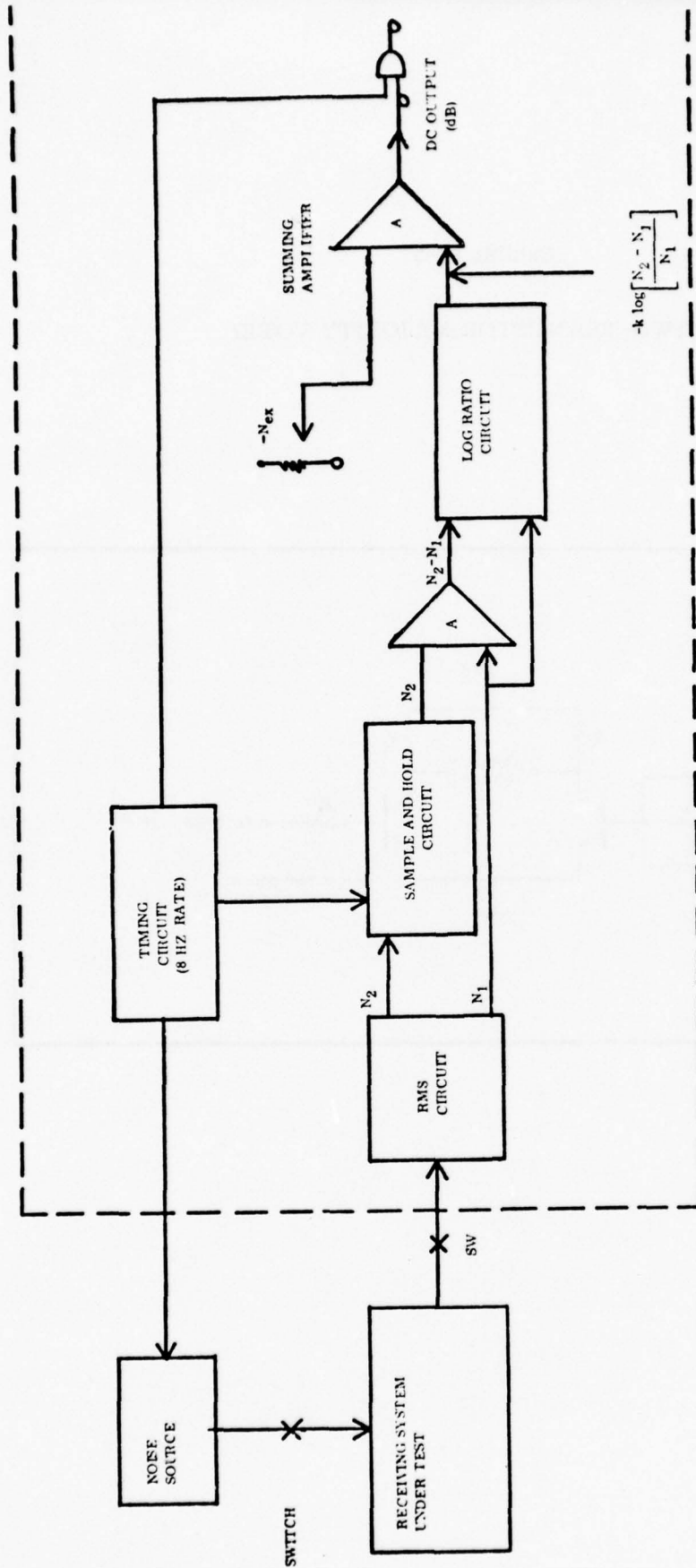

$$F \text{ (dB)} = N_{ex} - 10 \log \left[\frac{N_2}{N_1} - 1 \right]$$

N_{ex} = Noise Source Excess Noise Power in dB

N_1 = Noise Power Output of Receiver

N_2 = Noise Power Output of Receiver + Excess Noise

Exhibit 13-5

A TWO-TRANSISTOR MAJORITY VOTER

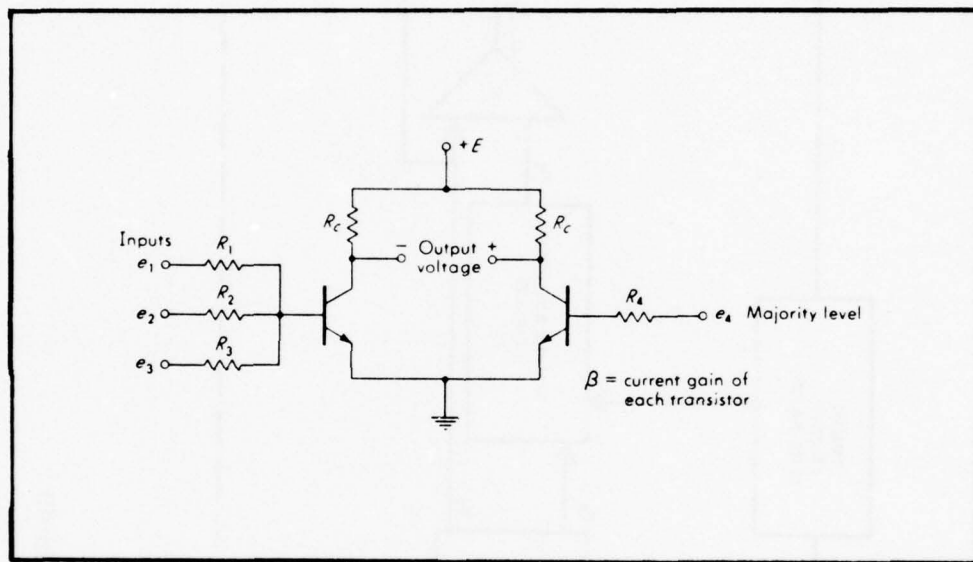

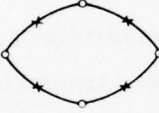
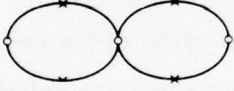
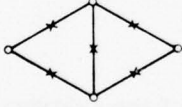

Exhibit 13-6

SWITCHING-CIRCUIT FAILURE
PROBABILITIES AND RELIABILITIES

(with $q_o = q_c = 0.1$)

<i>Circuit</i>	<i>Probability of stuck open</i>	<i>Probability of stuck closed</i>	<i>Reliability</i>
(a) 	0.1	0.1	0.8
(b) 	0.19	0.01	0.8
(c) 	0.01	0.19	0.8
(d) 	0.0396	0.0199	0.9405
(e) 	0.0199	0.0396	0.9405
(f) 	0.02152	0.02152	0.95606

q_o = probability of stuck open

q_c = probability of stuck closed

improve switching reliability. The series arrangement reduces short circuit probability but increases open circuit probability. The parallel arrangement acts conversely. Therefore, a more complex configuration is required to increase overall reliability as indicated.

The site maintenance configuration is shown in Exhibit 13-7. The power group and physical plant group are monitored continuously with the parameters indicated in Exhibit 13-3. The parameters are sensed, converted to D.C. levels and compared with a tolerance threshold. Exceeded threshold values are gated into the buffer store, where a continuous scan empties the stored value into a message register. The alarm message is encoded and transmitted to the Maintenance Subcenter and to the control site.

The radio group is not monitored continuously, but undergoes performance checks off-line as a result of entering spare status at maintenance personnel option. Each time a radio equipment is switched off-line by a controller action, the Radio Control Logic Interface signals the Sequencer to initiate a transmitter-receiver performance check. The Sequencer switches the noise figure and audio tone test set to the appropriate radio equipment and initiates a cycle of testing to determine parameters listed in Exhibit 13-3. Out-of-tolerance values are gated into the buffer store and transmitted to the Maintenance Subcenter.

Exhibit 13-8 shows a more detailed description of the CODEC/MODEM Group of Exhibit 13-7. Advantage is taken of the intermediate point at the radio facility to regenerate the signal and remove noise. The fact that the digital signals are coded for word error detection allows a performance check on both the Telco line and the radio channel. Excessive word error rates on either segment of the air/ground radio path will cause an increased frequency of requests for repeat. The RQs are monitored by the site processor and entered into the buffer store. Continuous RQs or high rates of RQs will cause a switch of telephone lines or radio equipments and a message to the Maintenance Subcenter.

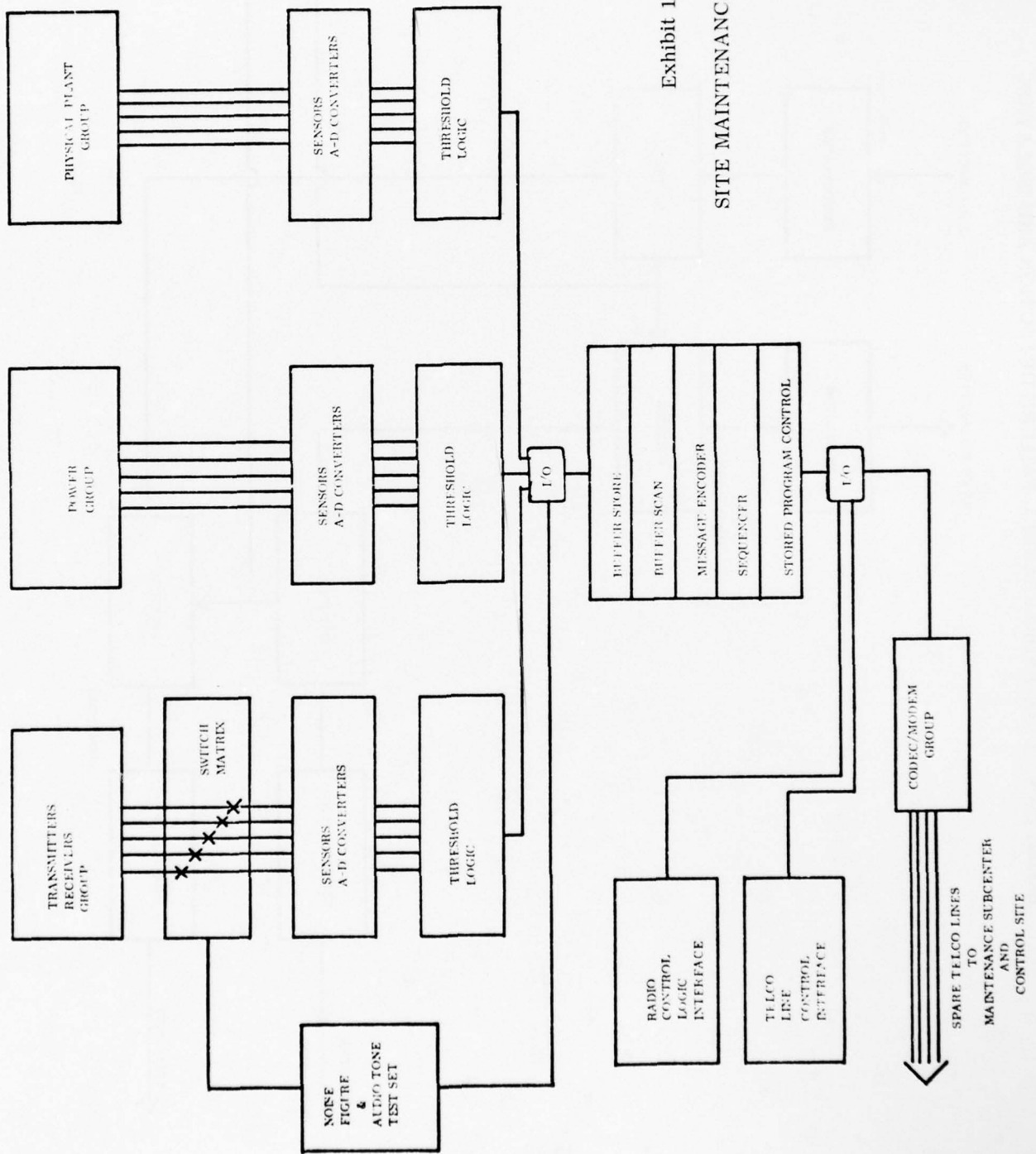
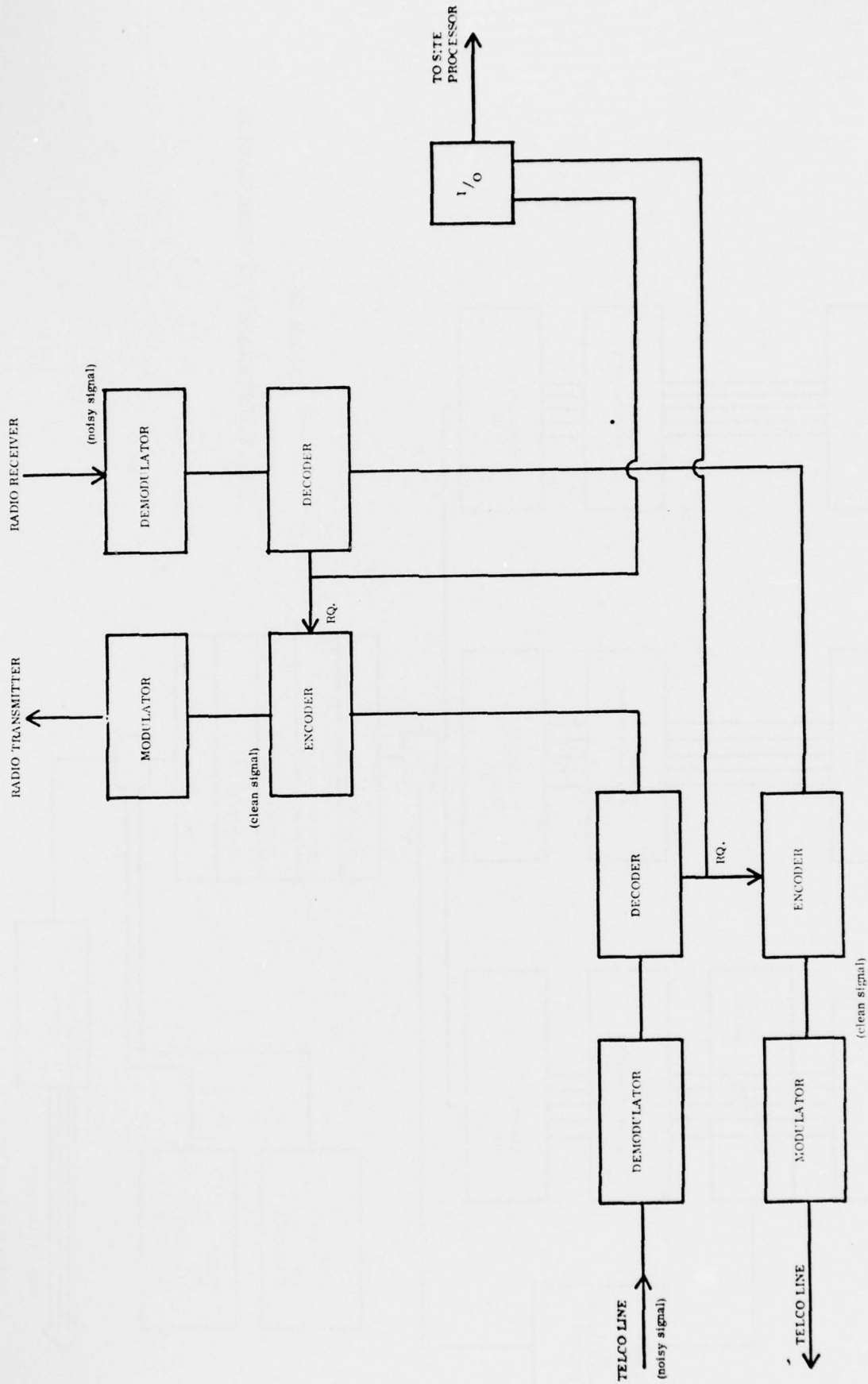

Exhibit 13-7

SITE MAINTENANCE CONFIGURATION

Exhibit 13-8: LINE/RADIO CHANNEL FAILURE DETECTION AND ISOLATION



The logical operations described may also be applied to voice operations by applying digital idle messages on all unoccupied voice lines and utilizing the CODEC/MODEM Group to detect and isolate failed telephone lines.

The site maintenance configuration described is also applicable to the en route/flight services radio facility.

Both the Terminal (TCOM) facilities and the NAVAID facilities may be included with suitable modifications to encompass differences in assigned equipments, and so forth.

13.5 MAINTENANCE SUBCENTER

The Maintenance Subcenter interfaces with the site maintenance configuration described above. The Subcenter also includes the air/ground radio service network concentrator described in Chapter 12.

The Subcenter functions as a central reporting location for all radio facilities within its sector. As a maintenance activity, the Subcenter will display active status of the radio facilities, their remote telephone lines, and radio channels. The Subcenter will also perform performance checks on spare telephone lines and off-line radio equipments as required. All site radio equipments may be checked by alternately switching equipments to spare status.

Detection of failures in any of the air/ground system elements will initiate appropriate maintenance procedures for the indicated facility through the Airways Facility Sector Office.

Both the Airways Facility Sector Office and the control site will be provided with remote terminals that give summary information on operational status and failed elements.

Exhibit 13-9 shows an initial outline configuration for the Maintenance Sub-center. Failure messages and test result messages are intercepted at the Sub-center and displayed at a maintenance position. The positions are also employed to generate site tests through the facility and line sequencer. Record keeping is accumulated within the record store, which may be accessed by the maintenance positions within the subcenter, at the AF Sector Office or at the control site maintenance position.

Voice signaling normals through the communications concentrator, bypassing the CODEC/MODEM Group which operates on digital signalling for radio network control, radio control and data transmission.

13.6 SUMMARY

The concept of automated maintenance offers the advantage of real time operations, automatic service restoral, record keeping and direct interactive coupling to the radio facilities. The approach achieves cost-effectiveness through a substantial anticipated increase in maintenance productivity which results from reducing the site visitation frequency by an estimated ratio between 12 to 1 and 24 to 1.

This cost advantage is offset by the fixed capital cost of the Subcenter configuration as well as the recurrent operating costs associated with assigned personnel. However, on balance, air/ground operations will realize an increased level of performance consistent with National Airspace Automation requirements.

Exhibit 13-9: MAINTENANCE SUBCENTER

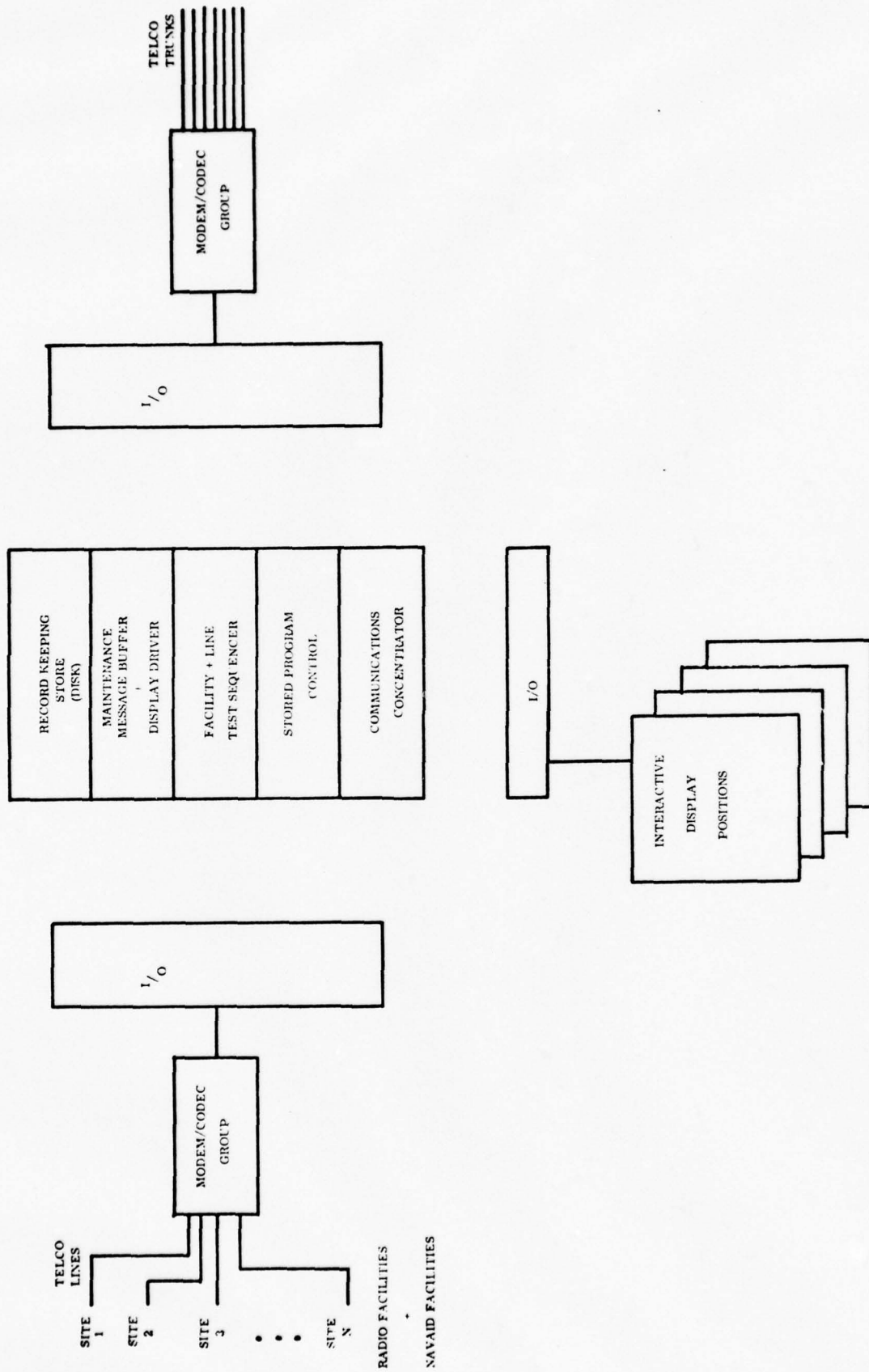

14

SEMI-AUTOMATED ATC OPERATIONS

14.1 INTRODUCTION

The current ATC system demonstrates an unbalanced operation. Significant automation has been introduced to the flight plan handling and surveillance display functions through the NAS-ARTS programs. At the same time, however, the communications function has remained a manual operation utilizing voice radio for its information transfer, even though, from a technological viewpoint, the automation of communications through the implementation of digital techniques is well within the state of the art.

Air/ground communications represents a most natural candidate for digital data transmission, since the language is limited in its alphabet and comprises a high percentage of alphanumeric transactions. There are no available statistics on current air/ground message errors, but limited samples indicate that errors through misunderstanding and garble are common. The most frequent mixup occurs during congested operations in the Terminal Area, when the air traffic controller sequences through a number of aircraft and does not have sufficient time to allow a readback of the instructions. Numerics transmitted that describe direction (vectors), speed, and altitude are particularly susceptible to errors in reception and interpretation.

The reconfiguration of the air/ground network resulting in a digitally controlled circuit switching operation provides the potential for upgrading the

communications to interface with the automated portions of the National Airspace System. A major percentage of the information base from which air/ground messages are formulated is already in store within the NAS/ARTS processors. The UTG Programs discussed in Chapter 6 will increase the potential interface opportunities for digital communications.

The integration of en route, terminal and flight service air/ground facilities presents a flexible and extensive set of remote outlets that can be configured to provide voice and data service to the aviation community.

14.2 AIR TRAFFIC CONTROL COMMUNICATIONS LANGUAGE

The language utilized for air traffic control and flight services is a limited subset of the English language. The limitation is evident in the vocabulary size of approximately 1,000 words. An average vocabulary size for telephone conversations is 50,000 words. These numbers can be compared to a recognition vocabulary of 100,000 words. The restricted vocabulary is an aid to air/ground communications because of the reduced choices available, together with established word association--e.g., turn-left--require relatively less signal power.

Exhibit 14-1 shows a complete set of air/ground message categories.

A sampling of current air/ground communications demonstrates the utilization of alphanumerics as the primary method of information exchange. In an airspace environment, relative position is the basis of air traffic flow regulation; this, together with the need for abbreviated conversations, has led to a language with a concentration of numerics.

The categories shown are applicable to all operating positions. That is, a message set specific to an operating position can be drawn from Exhibit 14-1. The categories shown are more fully explained below.

14.2.1 Address

The air/ground radio system is a channel-sharing operation among ground

Exhibit 14-1

ATC LANGUAGE CATEGORIES

- ADDRESS
 - Aircraft
 - Ground Position
- CALIBRATION SYSTEM
 - Radio System
 - Beacon Code
 - Barometric Pressure
 - Time
- AIR TRAFFIC CONTROL
 - Navigation Orientation
 - airway
 - fix
 - hangar/gate
 - runway/taxiway
 - Control
 - horizontal
 - vertical
 - speed
 - distance
 - Traffic Advisory
 - direction
 - distance
- PLANS
 - Clearance Delivery
 - Clearance Limits
 - Flight Plan Changes
- GENERAL STATUS
 - Environment
 - weather
 - turbulence
 - restrictions
 - Airport
 - NAS
 - Navaid
 - radar
 - comm.
 - facility
 - Airspace
 - air activity
 - flow patterns
- EMERGENCY SERVICE

positions and multiple aircraft. Each user must identify himself with an appropriate call sign. The aircraft are identified by FAA authorized call signs (e.g., United 223); or by aircraft type, make and model, or by designation "November" followed by the aircraft registration number (e.g., Cessna 60439).

Ground positions are normally identified by the facility name and the operating function, e.g., Washington Tower. Since each communication transaction must be prefaced with a unique address, the address represents a substantial part of the total communications volume. The address is frequently dropped or abbreviated during busy periods when multiple exchanges are involved. However, the probability of ambiguity among receivers increases the potential for confused signalling.

A coded, digital, unique address would perform the addressing functions more efficiently and more reliably than voice signalling.

14.2.2 Aircraft System Calibration

As aircraft move through the National Airspace, a number of specific calibrations are required in order for the aircraft to participate in system operations. The air/ground radio frequency, the ATCRBS code setting, and the local barometric pressure are set to values that vary as a function of geographic location. The effectiveness of data link communications is particularly evident in performing repetitive functions, such as calibration information, that comprise sequences of numbers.

14.2.3 Air Traffic Control

ATC communications include all transactions that transfer information or instructions directly affecting the flight path of the aircraft. Such communications are distinguished by their real-time response generated as a function of the controllers' observation of the air situation.

Air traffic control instructions are normally issued as changes in relative position, so that a navigation basis is usually provided as part of the message-- "cross runway 21-R"; vector 320 and intercept Kenyon Radial"; etc.

Radar Traffic Information Service or Traffic Advisories are normally provided to aircraft at the discretion of the controller, depending upon workload and information available. Traffic advisories are provided in terms of a target's position relative to the aircraft receiving the advisory.

Again, as in the categories of Address and System Calibration, ATC transactions are alphanumerically oriented. Numbers are transmitted representing direction, speed, and altitude relative to coded reference points such as airways, taxiways, runways and other fixes.

Voice communications are not suited to the transfer of numerics since the normally present English language redundancy and the supporting context of word associations do not apply. Coded data transmission would allow accurate, unambiguous transfer of numerics to any desired degree of reliability.

14.2.4 Flight Planning Operations

Flight operations are based on the initial filing of a flight plan that outlines the intended flight profile and time of system entry. The clearance delivery function starts the aircraft flight process by approving the submitted flight plan with any necessary modifications. During the course of a specific flight, an aircraft may be deviated from the intended flight path by the controller, or the aircraft may request a change in the planned flight path. Flight planning communications occupy a category of messages pertaining to future activity and are normally removed from real-time response requirements.

Real-time instructions for flight path modification belong to the ATC class of communications, while instructions or requests for modification of future flight path trajectories belong to the planning category. Flight plan communications can be compressed and coded--as in the case of the present STAR, SID instructions -- and therefore are amenable to data transmission techniques. In its simplest form, a flight plan comprises a series of vectors and altitudes related to fixes, airways, or airports.

14.2.5 General Status

General **status** encompasses all information elements that support successful flight operations. Flight operations are affected by:

- environmental conditions--weather, wind, turbulence, obstructions, etc.
- airspace conditions--air activity density, route operations, etc.
- terminal conditions--airport runways, taxiways, gate availability, etc.
- National Airspace System conditions--radar, communications, NAVAIDS, etc.

The status category of communications is non-ATC and covers a wide diversity of data of interest to airmen. Such data are provided primarily by the Flight Services function, although controller positions also supply data when workload conditions allow. Additionally, data of general use are broadcast over Terminal Areas (ATIS) and also over Flight Service Station areas (TWEB, etc.).

Of all the categories of information discussed, the Status category is most strongly narrative oriented. That is, the content of the messages normally requires an initial orientation followed by a specific statement of condition. Since data are being reported describing conditions of weather, facilities, air activity, etc., the communications can be easily coded into digital format. However, the average message length is sufficient to require some form of storage and readout capability on the flight deck. That is, an n-window display that may prove adequate for other communications categories is not suited for status display. Some form of hard copy or voice narrative appears warranted for this class of information transfer.

14.2.6 Emergency Operations

An aircraft that declares an emergency condition via the emergency communications channel alerts all ground stations within line-of-sight radio coverage to stand by for assistance. The most common emergency is lost or disoriented general aviation pilots. In this instance, Direction Finding service is available to augment the Radar-ATCRBS configurations. Following aircraft position location, it is expected that an extensive communications exchange will occur between the pilot and an appropriate ground position.

The handling of emergencies is best accomplished via voice communications due to the unstructured and unpredictable content of the exchange.

14.2.7 Summary of Language Considerations

An examination of air/ground communications operations demonstrates a utilization of a specialized language characterized by a relatively small vocabulary, a major employment of alphanumerics, and a substantial weighting of message flow in the ground-to-air direction.

14.3 EFFICIENCY OF AUTOMATED AIR/GROUND COMMUNICATIONS

An Air Traffic Controller utilizes a substantial percentage of time in handling air/ground communications. Air/ground radio channel utilization, which may be viewed as equivalent to controller communications workload, is variable as a function of an activity and type of sector. Exhibit 14-2 shows the results of an analysis of two hours of data collected over all 101 sectors of the New York ARTCC (1969).¹ It is seen that channel utilization is widely variable over the sectors, with 35 percent representing an overall average.

Exhibit 14-3 illustrates the distribution of message types, as taken from the same report (Volume 2). The message categories that account for a major portion of the communications are all alphanumerics. It should be noted that these figures are biased toward air carrier operations in the New York area and do not reflect the general aviation communications traffic, which is more narrative in form.

1. "Modeling Air Traffic Performance Measures," NAFEC Interim Report, July 1973.

Exhibit 14-2
CHANNEL UTILIZATION - PILOT AND CONTROLLER

ENROUTE SECTORS

Sector ID	Channel Pilot	Utilization Controller	All
451 R05 LT	0.165	0.221	0.386
453 R07 LT	0.153	0.328	0.481
454 R11 LT	0.184	0.329	0.513
455 R12 LT	0.101	0.261	0.362
456 R13 LT	0.160	0.427	0.587
457 R16 LT	0.094	0.164	0.259
458 R17 LT	0.158	0.219	0.377
459 R23 LT	0.109	0.237	0.346
460 R24 LT	0.204	0.361	0.565
461 R25 LT	0.146	0.134	0.280
462 R27 LT	0.145	0.181	0.326
463 R28 LT	0.133	0.167	0.299
LT Function	0.146	0.252	0.399
464 R02 LE	0.208	0.285	0.493
465 R03 LE	0.091	0.084	0.174
466 R04 LE	0.197	0.378	0.575
467 R05 LE	0.138	0.318	0.457
468 R09 LE	0.162	0.207	0.369
469 R18 LE	0.068	0.083	0.152
470 R20 LE	0.112	0.150	0.262
471 R21 LE	0.167	0.158	0.326
472 R26 LE	0.173	0.261	0.434
473 R29 LE	0.213	0.265	0.478
474 R30 LE	0.175	0.195	0.370
LE Function	0.155	0.217	0.372
475 R01 HI	0.194	0.357	0.551
476 R08 HI	0.148	0.266	0.414
477 R08 HI	0.158	0.149	0.306
478 R13 HI	0.127	0.373	0.500
479 R14 HI	0.155	0.199	0.354
480 R19 HI	0.165	0.223	0.388
481 R22 HI	0.174	0.283	0.457
482 R35 HI	0.095	0.170	0.264
483 R36 HI	0.134	0.183	0.317
HI Function	0.150	0.245	0.395

TOWER CAB SECTORS

Sector ID	Channel Pilot	Utilization Controller	All
484 BMR CD	0.245	0.275	0.520
485 JPK CD	0.244	0.090	0.334
486 LGA CD	0.203	0.130	0.333
487 PHL CD	0.146	0.121	0.267
CD Function	0.210	0.154	0.363
488 ACY GN	0.086	0.034	0.120
489 BMR GN	0.061	0.022	0.084
490 BMR GN	0.251	0.119	0.371
492 HFN GN	0.177	0.054	0.231
494 ISB GN	0.156	0.070	0.223
495 JPK GN	0.197	0.178	0.375
496 JPK GN	0.110	0.067	0.177
497 LGA GN	0.306	0.205	0.511
498 LRP GN	0.050	0.022	0.072
501 PHL GN	0.282	0.134	0.416
502 PNB GN	0.055	0.032	0.087
503 RDD GN	0.051	0.014	0.065
504 TEB GN	0.274	0.233	0.507
GN Function	0.159	0.091	0.250
506 ACY LC	0.114	0.056	0.170
507 BDR LC	0.210	0.144	0.354
508 BMR LC	0.234	0.162	0.395
509 HAR LC	0.175	0.093	0.269
510 HFN LC	0.282	0.268	0.550
511 ILG LC	0.207	0.137	0.344
512 ISB LC	0.260	0.236	0.496
513 JPK LC	0.094	0.086	0.180
514 JPK LC	0.222	0.144	0.366
515 LGA LC	0.240	0.332	0.573
516 LRP LC	0.157	0.070	0.227
517 MDT LC	0.050	0.014	0.063
519 PHL LC	0.272	0.251	0.522
520 PNB LC	0.137	0.052	0.189
521 RDD LC	0.143	0.097	0.240
522 TEB LC	0.338	0.253	0.590
LC Function	0.192	0.150	0.341
524 ABE IO	0.231	0.073	0.305
525 AVP IO	0.070	0.029	0.099
526 PDM IO	0.122	0.067	0.189
527 PDM IO	0.192	0.111	0.303
528 IPT IO	0.129	0.055	0.184
IO Function	0.149	0.067	0.216
529 ABE AP	0.083	0.081	0.164
530 BEM AP	0.041	0.020	0.061
531 HFN AP	0.091	0.054	0.145
532 RDB AP	0.027	0.008	0.036
AP Function	0.061	0.041	0.101

IFR ROOM SECTORS

Sector ID	Channel Pilot	Utilization Controller	All
533 ACY DP	0.086	0.168	0.254
534 BMR DP	0.199	0.235	0.434
535 JPK DP	0.159	0.255	0.414
536 LGA DP	0.118	0.239	0.357
537 PHL DP	0.097	0.094	0.190
538 PHL DP	0.063	0.108	0.170
DP Function	0.120	0.110	0.188
539 AVP AD	0.065	0.038	0.103
540 BMR AD	0.057	0.169	0.226
541 HAR AD	0.073	0.037	0.110
543 HAR AD	0.081	0.062	0.143
543 PHL AD	0.140	0.244	0.383
544 PHL AD	0.054	0.091	0.145
AD Function	0.078	0.110	0.188
545 ACT AR	0.127	0.096	0.222
546 BMR AR	0.088	0.145	0.234
547 BMR AR	0.150	0.222	0.373
548 BMR AR	0.088	0.152	0.240
549 JPK AR	0.126	0.335	0.461
550 JPK AR	0.115	0.338	0.453
551 JPK AR	0.097	0.363	0.479
552 LGA AR	0.098	0.191	0.289
553 LGA AR	0.176	0.370	0.546
554 LGA AR	0.157	0.405	0.562
555 PHL AR	0.164	0.312	0.475
556 PHL AR	0.082	0.234	0.317
AR Function	0.122	0.274	0.396
557 BMR RA	0.221	0.157	0.379
558 JPK RA	0.154	0.184	0.339
559 LGA RA	0.297	0.252	0.549
RA Function	0.224	0.198	0.422

Exhibit 14-3

DISTRIBUTION OF MESSAGE TYPE FOR SINGLE-MESSAGE TRANSMISSIONS
 (Sector Group XX) New York: All Single-Message Transmissions)

- 110 - A/C Vector Heading
- 130 - Altitude Control
- 150 - Clearance Control
- 210 - Call up (radio contact)
- 220 - Beacon Control
- 230 - Hand off/Frequency change
- 310 - Position Report
- 320 - Altitude Report
- 410 - Traffic Advisory
- 640 - Pause

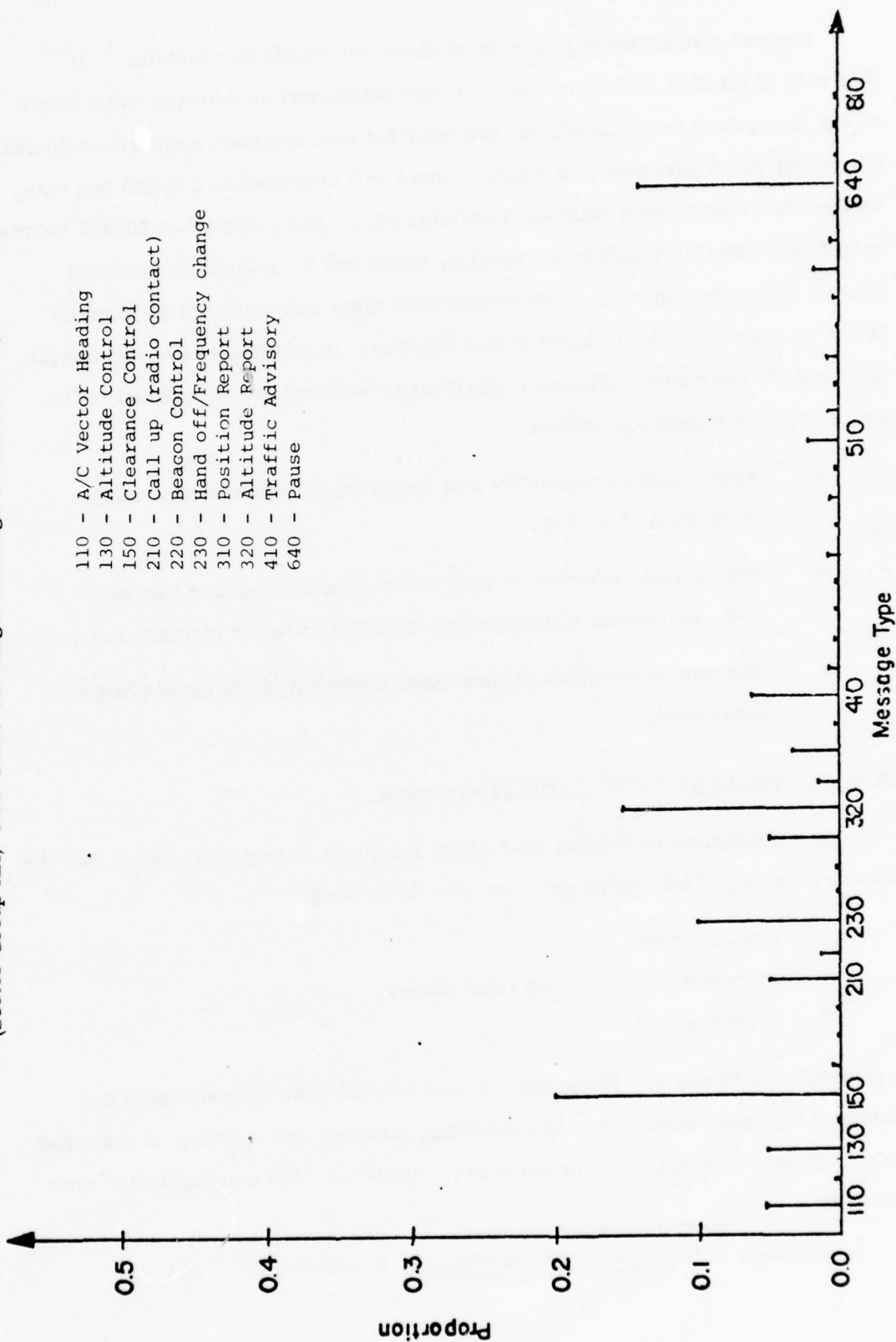

Normal conversation proceeds at about 165 words per minute.¹ If this rate is doubled (330 wpm) for ATC operations and an average word length of six characters is assumed, the effective bit rate becomes approximately 264 bps (eight bits/character). A voice channel will accommodate a 2,400 bps rate, so that the compression ratio is approximately 10 to 1. That is a 10-to-1 increase in channel/controller efficiency results, which can be applied to enhanced system cost-effectiveness. Communications time that occupied 35 minutes out of an hour would be reduced to 3.5 minutes. In addition to the substantial gain in ATC operations efficiency, there are additional gains realized in the radio communications operation:

- Fewer radio frequencies are required, because sectors may be increased in size.
- The 10-to-1 reduction in duty cycle affects telephone line and radio equipment utilization by resulting in fewer circuits and radios.
- The communications maintenance workload is correspondingly decreased.

14.4 CONTROLLER INTERFACE FUNCTIONS

An examination of Exhibit 14-1 (ATC Language Categories) shows that the list can be grouped into three primary sets describing:

- (1) System status
- (2) System action-reaction (real time)
- (3) System plans

In general, the Status and Plans sets of data are not real time oriented and therefore are quite susceptible to recording, storing, and updating as required. Once in store, such data may be accessed, retrieved, and communicated upon command.

1. Carroll, J. B., Language and Thought, Prentice-Hall, 1965

Data set (2) occurs in real time and forms the nucleus of the controller's decision-making function. As was discussed in Chapter 6, a number of these real time actions that are related to separation assurance require automated processing and communications in order to satisfy response time requirements.

The following paragraphs indicate the interface structure associated with each language category listed in Exhibit 14-1.

14.4.1 Address (Status)

Both aircraft call sign (ID) and ground station call sign are available information elements. The aircraft ID appears on all flight plans that enter the NAS processors.

14.4.2 Calibration System (Status)

These information elements are "housekeeping" functions that allow the aircraft to operate in the ATC system. The radio system calibration is of particular interest, since a number of housekeeping functions may be automated, relieving the controller of time-consuming, repetitive tasks.

The group of messages comprising the radio frequency, beacon code, and altimeter reading may be routinely transmitted from the controller position as the position receives the handoff acceptance from the adjacent position (sector).

As an IFR aircraft enters a sector, the handoff transaction will initiate the data communication to the aircraft. The appropriate radio frequency, beacon code, and barometric pressure are selected from storage and transmitted.

The implementation of a circuit-switched air/ground communication network will allow the air/ground channels to be activated automatically on demand. The operation of handoff, which identifies the IFR flight operation, can also be utilized to trigger the activation of the required air/ground radio channel, and equipment will be switched into readiness for communications.

Such an automated set of operations is effective in optimizing the utilization of telephone lines and radio equipments. A further advantage is the capability of discriminating between VHF and UHF operations. With this logic of operations applied, UHF radio frequencies (radio equipments) will be activated and keyed only when military aircraft enter a specific sector. Further, VHF and UHF transmitters will be connected to their respective antennas only when activated by aircraft entering a sector volume. This contributes to reduction in transmitter-generated intermodulation products.

14.4.3 Air Traffic Control (Action-Reaction)

Air traffic control in real time is the primary responsibility of the controller. If an automated metering and spacing system is operational, the air/ground data communications will handle the up-link instructions. Both Air Traffic Control and/or Traffic Advisory messages generated by the Conflict Alert System or IPC can also be handled by air/ground data communications.

A substantial advantage in real-time operations is gained through the use of VHF/UHF data communications, due to the provision of immediate random access, which avoids the delay, caused by antenna rotation, inherent in the DABS configuration.

14.4.4 Plans (Plans)

The Clearance Delivery Message is a repeat of the filed flight plan, with modifications and clearance limits. Such messages are easily handled by data communications. The most effective procedure is to clear the flight plan as filed with added exceptions or modifications.

In-flight flight plan changes normally will involve an exchange between pilot and controller in order to determine the flight path desired and the flight path available. Both of these parameters are dynamic variables dependent upon

air activity, weather, time, etc. It appears that in-flight flight plan changes are best handled in the voice mode.

14.4.5 General Status (Status)

Status-type data can be made available as local broadcast data, as specific aircraft-addressed bulletins, or in response to aircraft query for data. All status data, as identified in Exhibit 14-1 are recorded and therefore stored in the National Airspace System. They are thus available for retrieval and transmission either as a scheduled item or on request (a query item).

Data requests from aircraft for weather, airport, or other status can be directed to any point in the National Aviation System by utilizing a combination of digital air/ground communications interfaced with the point-to-point NADIN. A pilot may query directly to the WMSC in Kansas City for a readout of data describing localized weather, facility, or system status.

14.4.6 Emergency

Emergency communications occur in real time and are unstructured in format, so that the voice mode is preferred for air/ground communications. However, alerting messages to appropriate points (i.e., DF facilities, airport emergency facilities, etc.) may be automatically distributed upon receipt of the initial emergency communication.

14.5 VOICE/DATA INTERFACE

An evolutionary path exists that will encompass the implementation of a voice/data capability for the long-term radio communications services.

As was discussed in Chapter 10 on ZOA coverage and frequency assignments, it appears cost-effective to place primary radio frequency channels at the current en route facilities (i.e., RCAGs) to provide air/ground communications for both en route ATC and flight services. Additionally, secondary coverage is provided by utilizing an appropriate combination of en route and navigational

facilities. The navigational facilities (i.e., VORs) are employed to support FSS operations through the use of VOR (Tx.) and LRCO (Rec.) frequencies. The placement of tunable transceivers at the VORs provides further communications capability on a selective basis for either en route ATC or flight service operations.

The most natural progression is to introduce data link operations in the following sequence:

- (1) High-altitude en route operations
- (2) Low-altitude en route operations
- (3) Terminal operations
- (4) Flight service operations

For ZOA, this progression would initiate a data link capability for the Mt. Tamalpais Radio Facility that would provide HAT coverage over all en route sectors. The secondary HAT coverage provided at the designated secondary facilities would continue to operate in the voice mode.

The eventual long-term configuration will be comprised of data link at all primary en route and terminal radio facilities, with voice retained at all secondary radio facilities and the flight service radio facilities.

All IFR operations will be supported via data link with voice backup. All VFR operations will be supported with voice, with a data link option for those so equipped.

Since the network structure discussed in Chapter 12 provides a digitally controlled, circuit-switched configuration, the potential exists to handle either mode of communications.

The air/ground system configuration is shown in Exhibit 14-4, and integrates the following major operations:

Exhibit 14-4

AIR/GROUND VOICE/DATA CONFIGURATION

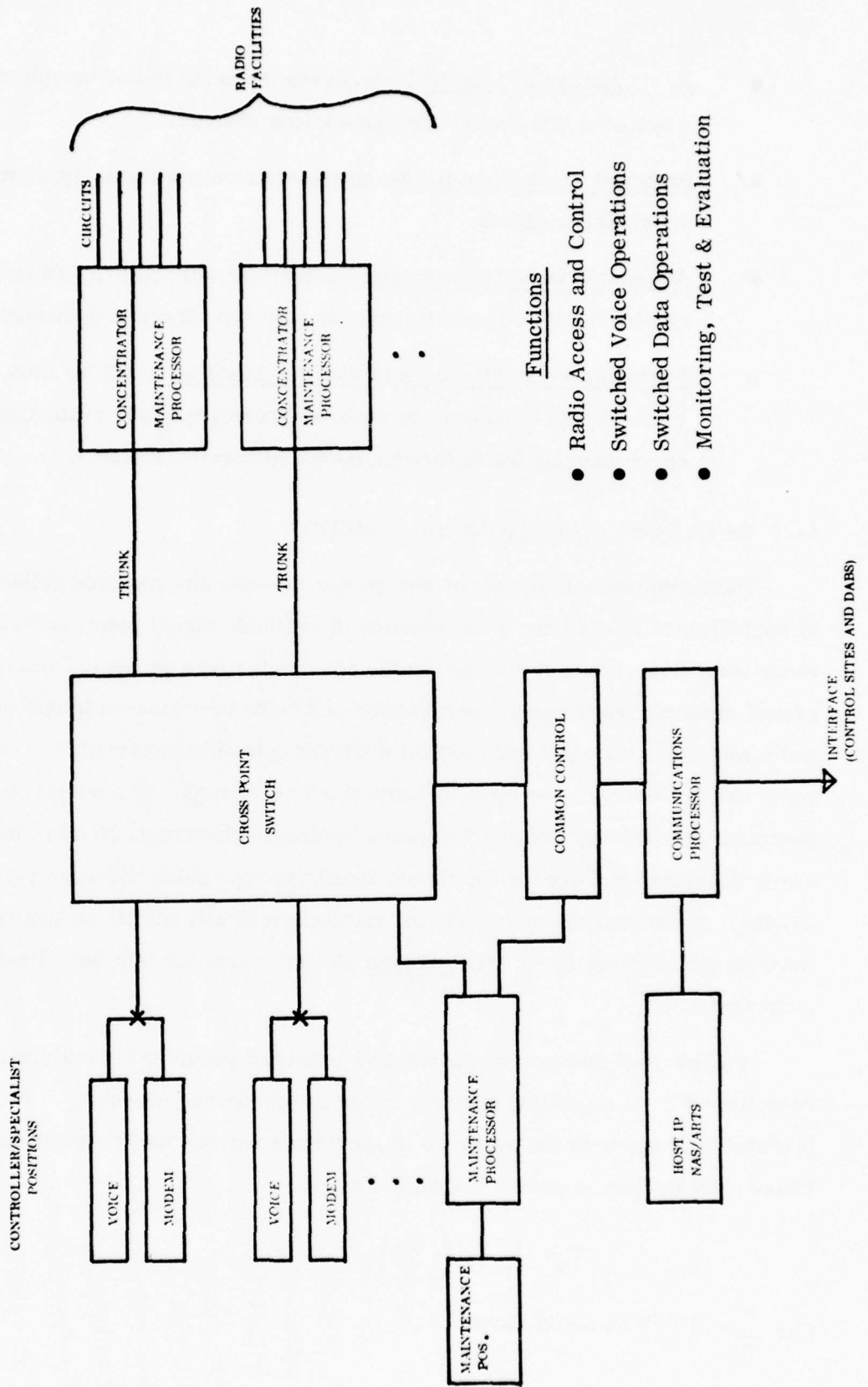

- Radio Access and Control--accesses the network and completes a selected air/ground communications channel.
- Switched Voice Operations--applies voice signaling at the controller/specialist positions.
- Automated Data Transmission--interfaces with NAS/ARTS and applies digital communications on selected air/ground channels.
- Performance Monitoring and Facility Testing--monitors line, radio and NAVAIID performance; and performs test, evaluation and recordkeeping for failure analysis and service restoral.

14.6 DATA COMMUNICATIONS RELIABILITY

Data communications can be designed to provide any required reliability of performance by applying a combination of available signal power and signal redundancy (i.e., coding) matched to the communications channel. An air/ground channel comprises a concatenation of 2 links in series--a telephone line and a radio channel--that each exhibit different noise characteristics. The radio channel noise can be approximated (for line-of-sight) by a normal or gaussian distribution, whereas telephone line noise characteristics are not easily described and are susceptible to impulsive type noise bursts of varying lengths. In the absence of coding, the radio channel will exhibit average error rates on the order of 10^{-5} . The average bit error rate for telephone lines is estimated at 10^{-3} .

Exhibit 14-5 shows a representative baseband receiver for optimum reception of PCM signalling utilizing integrate and dump processing. The probability of error in the presence of gaussian noise for DPSK (Differential Phase Shift Keying) is shown in Exhibit 14-5 as:

$$P_e \approx \frac{1}{2} \exp\left(-\frac{E_s}{\eta}\right)$$

For $\frac{E_s}{\eta} \sim 10$ dB as noted above.

Exhibit 14-5

DPSK SIGNALLING IN GAUSSIAN NOISE

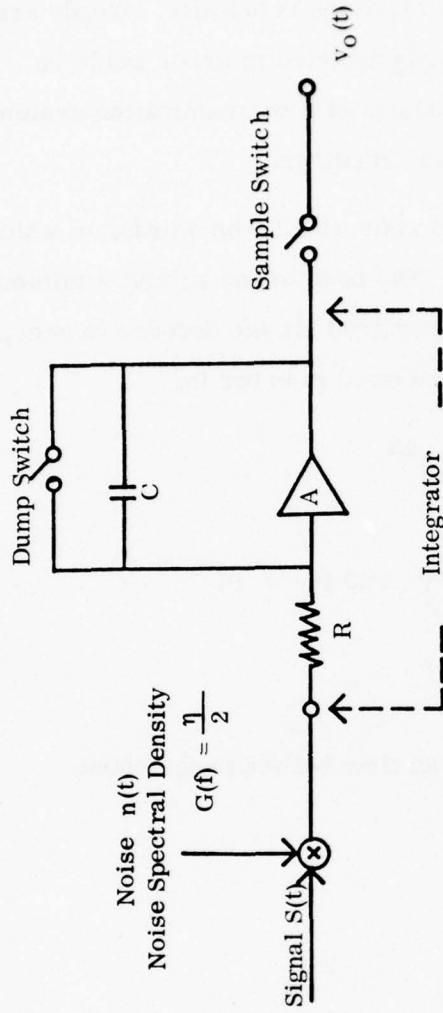
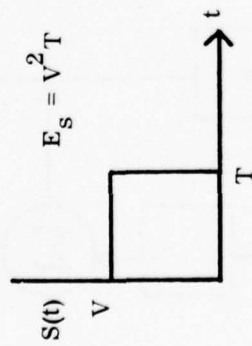

Optimum Detector

$$\text{DPSK : } p_e = \frac{1}{2} \exp\left(-\frac{E_s}{\eta}\right)$$

Probability of Error
for DPSK Signalling

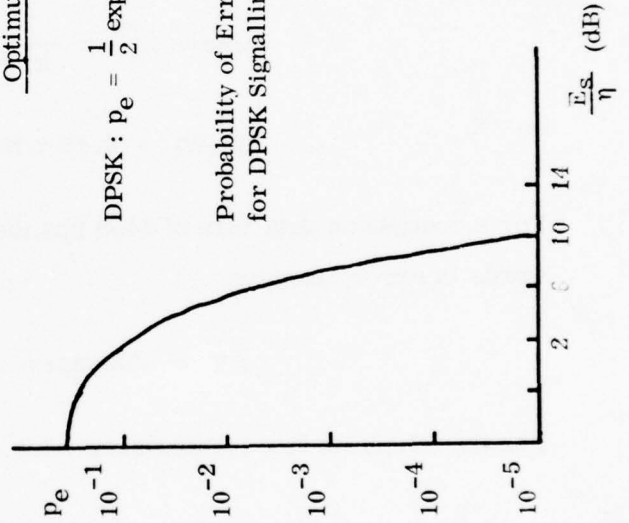

By applying a simple error detection code process to the data communications, it is possible to increase the communications reliability. Words are coded by adding check bits to each word. Words detected in error would be retransmitted. Such an approach allows the design of a communication system in which only correct words are accepted by the receiver.

Exhibit 14-6 shows the construction of a code with 15-bit words, of which 11 are information bits and 4 are check bits. The code words exhibit a minimum distance of three, i.e., three bit errors are required for the decoder to accept an incorrect word. The probability of an undetected word in error is:

$$P(W) = C_3^{15} P_e^3 (1-P_e)^{12}$$

$$\text{where } C_3^{15} = \frac{n!}{k!(n-k)!} \text{ and } P_e = 10^{-5}$$

$$P(W) = 0.45 \times 10^{-12}$$

For a continuous data rate of 2400 bps, the mean time between undetected words in error becomes

$$\Delta T = 435 \text{ years.}$$

For the telephone line transmission, i.e., $P_e = 10^{-3}$,

$$P(W) = 0.45 \times 10^{-6}$$

The above code is implemented with a feedback shift register encoder of (n-k) stages:

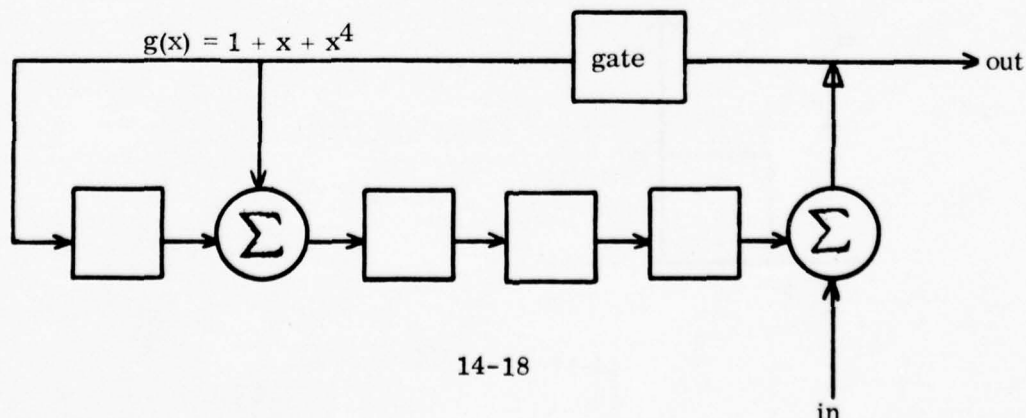

Exhibit 14-6

CODE CONSTRUCTION - $(n,k) = (15,11)$

- Consider the ring R of all polynomials with coefficients from $GF(2)$.
- Choose a polynomial $f(x) \in R$ with $f(x)$ of degree n such that:

$$f(x) = g(x) h(x) = 0$$

- For a cyclic group code with word length $n = 15$ and $k = 11$ then $g(x)$ is of degree $(n-k) = 4$ and is a generator of the code.
- Let $f(x) = x^{15}-1 = (1+x+x^4)(1+x+x^2+x^3+x^4)(1+x+x^2)(1+x)(1+x^3+x^4)$ and choose $g(x) = 1+x+x^4$ which defines an $(n,k) = (15,11)$ code.
- Thus $h(x) = (1+x+x^2+x^3+x^4)(1+x+x^2)(1+x)(1+x^3+x^4)$.

- The factors of $h(x)$ have the following roots:

$$e_1, e_2, \dots, e_k = 1, \beta, \beta^2, \beta^4, \beta^8, \beta^5, \beta^{10}, \beta^6, \beta^{12}, \beta^9, \beta^3 .$$

- The minimum distance between words is:

$$W_{\min} = n - (\text{maximum order of } e_k) = n-12 = 15-12 = 3.$$

- The resulting code has word length $= n = 15$ bits
with information bits $k = 11$
and check bits $(n-k) = 4$.
- Available alphabet $= 2^{11} = 2048$ words with minimum distance $= 3$.

The 11 data bits are fed into the shift register and also on line. The shift register calculates the check bits which follow the data bits.

14.7 SUMMARY

The implementation of VHF/UHF data link appears as a feasible and effective option for air/ground communications. It will provide an improved service consistent with the other automated portions of the NAS. The data link system offers a valuable long-term capability that can interface with the DABS, IPC, and conflict alert programs and also integrate with an improved voice radio service.

15

RADIO FREQUENCY ENVIRONMENT

15.1 INTRODUCTION

The analysis of Radio Frequency Interference (RFI) as applied to FAA's air/ground communications resists generalization, because of the extensive variety of facility configurations found in the field. Specialized restrictions exist that are peculiar to each specific Region and to facilities within a Region.

However, the variety of problems encountered produce common effects: either undesired on-frequency energy enters the receiving system, or less than the desired on-frequency energy is present. These effects are *in great part* due to gaps in radio coverage caused by destructive interference and by generation of intermodulation products due to RF signal interaction.

The problems encountered in the radio frequency environment can to some degree be alleviated through frequency management, designed to assure compatible frequency assignments that assure adequate separation. However, the practical utilization of radio facilities that must continually respond to modified or additional communication requirements results in the employment of practices and configurations not entirely consistent with frequency management principles. Additionally, an entire external (to FAA operations) environment exists that cannot be predicted in sufficient detail to minimize its effect.

In general, due to the diversity of problems encountered in the field, no documented data currently exist which catalog the occurrence and characteristics

of RFI phenomena, and particularly its causes. Site geometry is a prime suspect because of the proximity of antennas to one another and to a variety of elements capable of excitation at VHF and UHF frequencies. Potential for two-path or multipath conditions exists at most sites, which may well cause antenna pattern distortion.

The following analysis emphasizes aspects of site geometry relative to intermodulation interference and approaches a solution by minimizing the number of antennas and increasing the degree of isolation. It is felt that the amount of experimental data could well be amplified by a test and evaluation program directed toward identifying the sources and characteristics of the more common forms of interference. (This program has been initiated as Phase II of the current study.)

15.2 GENERAL SITING CONSIDERATIONS

Siting conditions for radio installations are almost never ideal. A variety of problems arises because of terrain interaction with radio wave propagation, and because of the interaction of radiating elements with one another and with man-made structures in the vicinity. For en route ATC service, radio facility sites are located at diverse remote locations; for terminal ATC service and flight services, sites are on or near airports. The two siting environments are dissimilar in that the en route sites are normally limited in available geographical space, while terminal sites may exercise some choice in separation of antennas.

At the same time, however, the Terminal Area is complicated by the range of ATC facilities that may be supported, i. e., non-towered airports, non-approach control (TRACON) facilities. The number of assigned radio frequencies increases with terminal air activity, so that major hubs may be assigned a large complement of radio channels. The siting variations may include FSS building roofs for non-towered air terminals, tower roofs, RTRs, RTs, RRs and TRACON roofs. Roof configurations of antenna installations are usually non-optimum because of antenna proximity to other antennas and to the roof surface. Because of available space, a typical air

terminal may divide its radio site into two or more facilities, in order to separate transmitting and receiving antennas, thus reducing radio frequency interference. However, it will be seen that the intermodulation products escalate rapidly with number of frequencies, so that a tradeoff becomes evident in which it may be more effective to utilize separated sites with mixed complements of transmitting and receiving antennas (similar to two RCAG's).

Some of the communications problems can be identified with the aid of a few figures. Exhibit 15-1 shows one of four typical towers at the NAFEC RCAG site. From this figure it is seen that there are two VHF antennas (one swastika, one coaxial dipole) and two UHF discone antennas mounted about eight feet above the service platform and spaced about its periphery. The antenna-to-antenna spacing is about eight feet. The swastika is used for transmitting and the coaxial dipole for receiving at VHF. The UHF antennas are separate discoses for the transmit and receive functions. It is evident that there are twice as many antennas as necessary because a single UHF antenna can be used at each single frequency for either transmission or reception, by employing a simple transmit-receive (TR) coaxial switch.

Note that the swastika antenna, which is shown in Exhibit 15-2, has been used for many years to radiate a random polarized (circular) field in the horizontal plane. The original development requirement for the swastika antenna apparently resulted from the fact that radios in light aircraft previously shared the horizontally polarized VOR antenna with both the communications channels and the VOR channels of a common receiver. Thus both horizontal and vertical components of field were required. Since these requirements no longer exist, it is desirable to match the vertically polarized communications antennas on all aircraft with the ground station antennas.

The published gain of the swastika antenna is typically -0.8 dB, with respect to a vertically polarized signal. Since the coaxial dipole has a gain of $+2.2$ dB, an immediate system gain of 3 dB can be realized by using the coaxial dipole for transmitting, instead of the swastika. It is also seen that if this coaxial dipole is used for both the transmit and receive function, then the total number of antennas on a typical RCAG tower can be reduced from four to two.

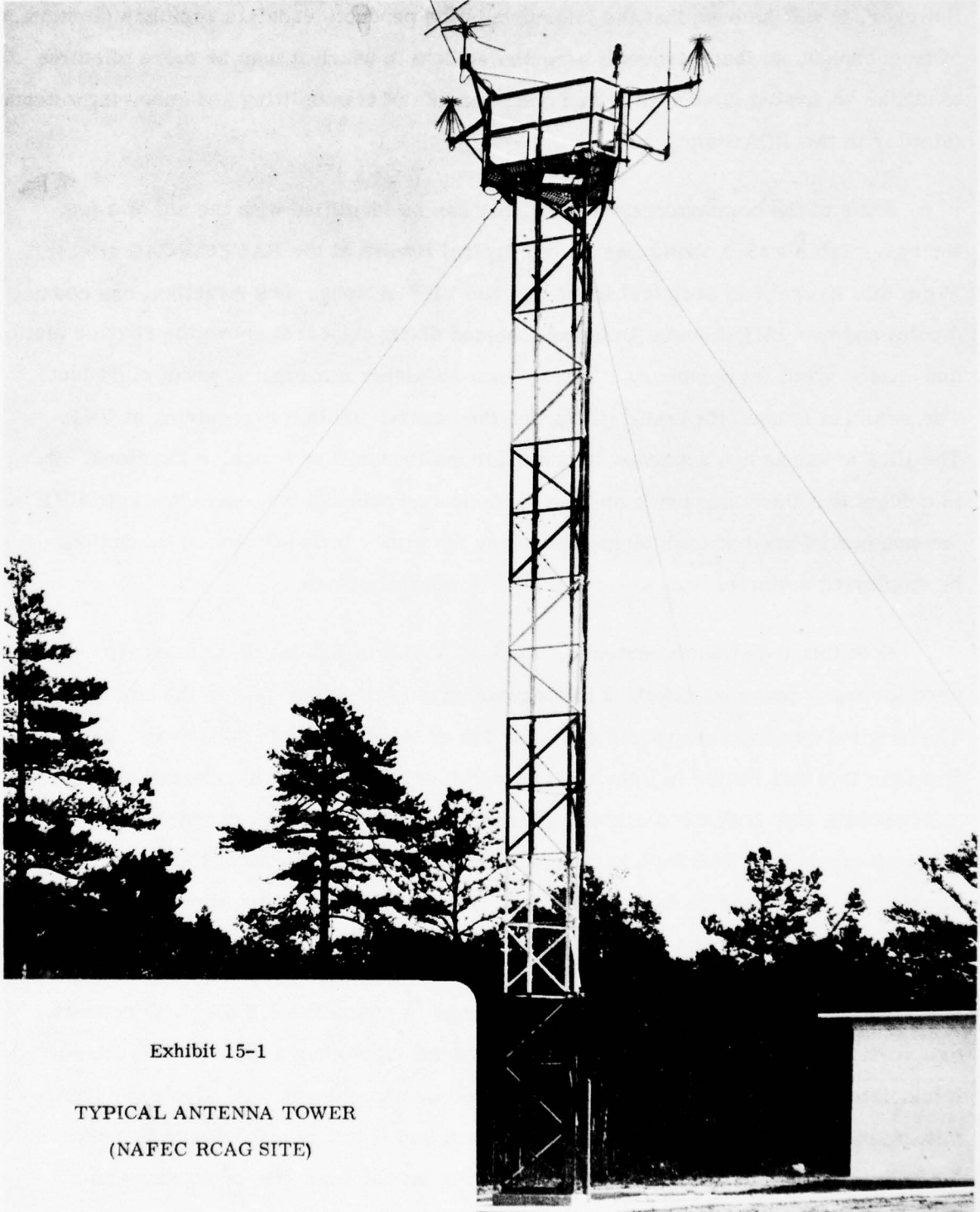
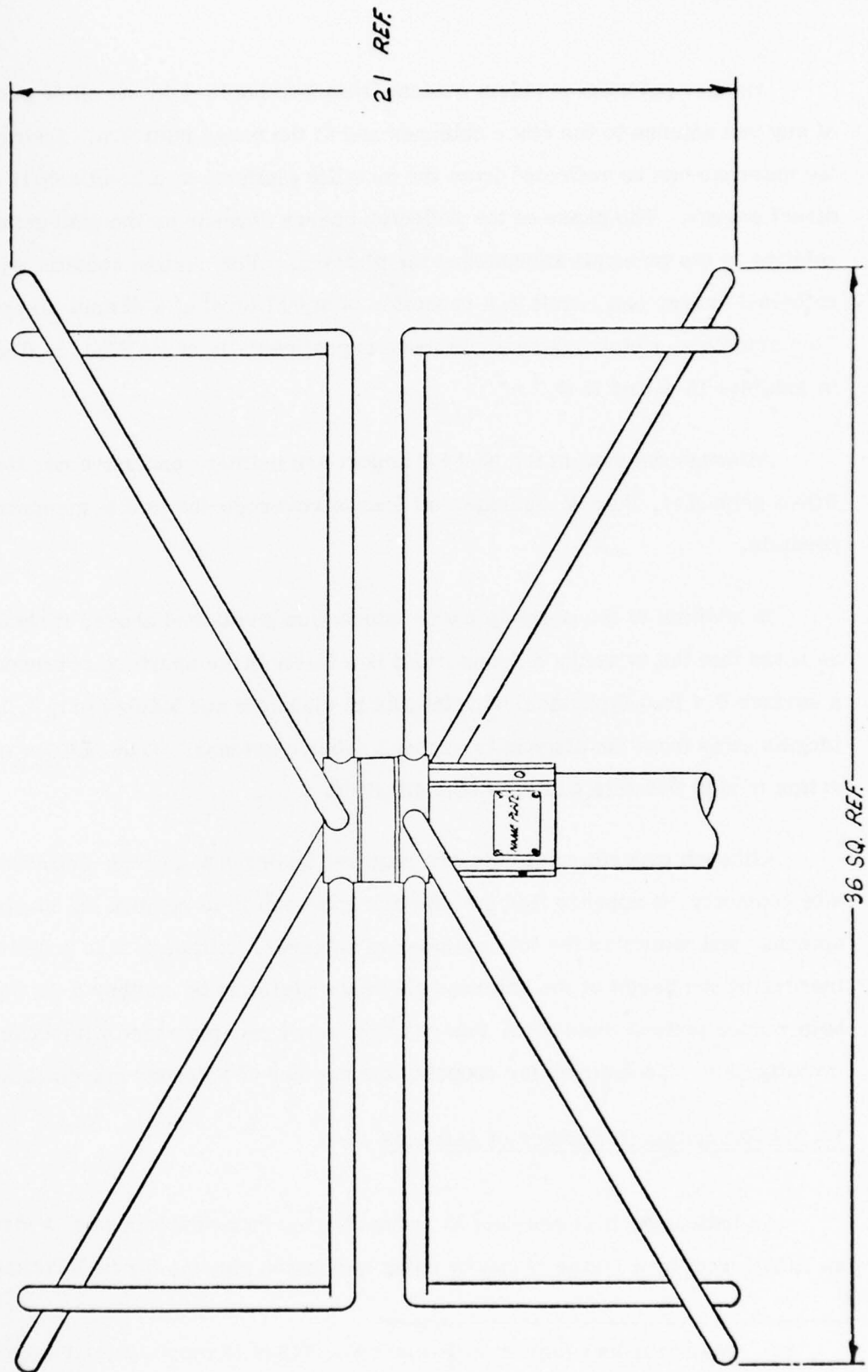

Exhibit 15-1

TYPICAL ANTENNA TOWER
(NAFEC RCAG SITE)

Exhibit 15-2

CIRCULARLY POLARIZED VHF ANTENNA



Another potential problem evident from Exhibit 15-1 is the close proximity of any one antenna to the other antennas and to the tower platform. Energy from the antennas can be reflected from the metallic platform at a level nearly equal to the direct energy. The phase of the reflected energy depends on the path geometry relative to the transmit antenna and the platform. For certain conditions, this reflected energy can result in a reduction of signal level at a distant aircraft. This symptom, which has been observed experimentally at NAFEC, is illustrated in Exhibits 15-3 and 15-4.¹

Although the data in the NAFEC report are neither conclusive nor tied to the RCAG geometry, they do indicate that loss of coverage due to site geometry is possible.

In addition to the possible tower interaction mentioned above, it should also be noted that the swastika antenna itself is a fairly large aperture corresponding to a surface 0.4 to 0.5 physical wavelengths in diameter and located only 1.5 wavelengths away from the diagonally opposed receive antenna. Thus pattern interaction is also possible with this configuration.

Although experimental data are required in order to provide definition to site geometry, it appears that an effective approach is to remove the swastika antenna and minimize the total number of antennas. Although it is possible that increasing the height of the antennas above the platform by another 8-12 feet may help reduce pattern distortion, this solution is not recommended without further investigation. Techniques for reducing the number of antennas are discussed below.

15.2.1 Reduction in Number of Antennas

As indicated, it is possible to reduce the number of antennas at a given site (e.g., an RCAG site) by a factor of two by using a common antenna for both transmit and

1. "Memorandum Report on Project No. 718-8 'Experimental Peripheral Communications Facility at NAFEC,'" January 14, 1963.

UHF HORIZONTAL PLANE ANTENNA RADIATION PATTERN

VALUES SHOWN ARE
FIELD INTENSITY
MEASUREMENTS IN
MICROVOLTS

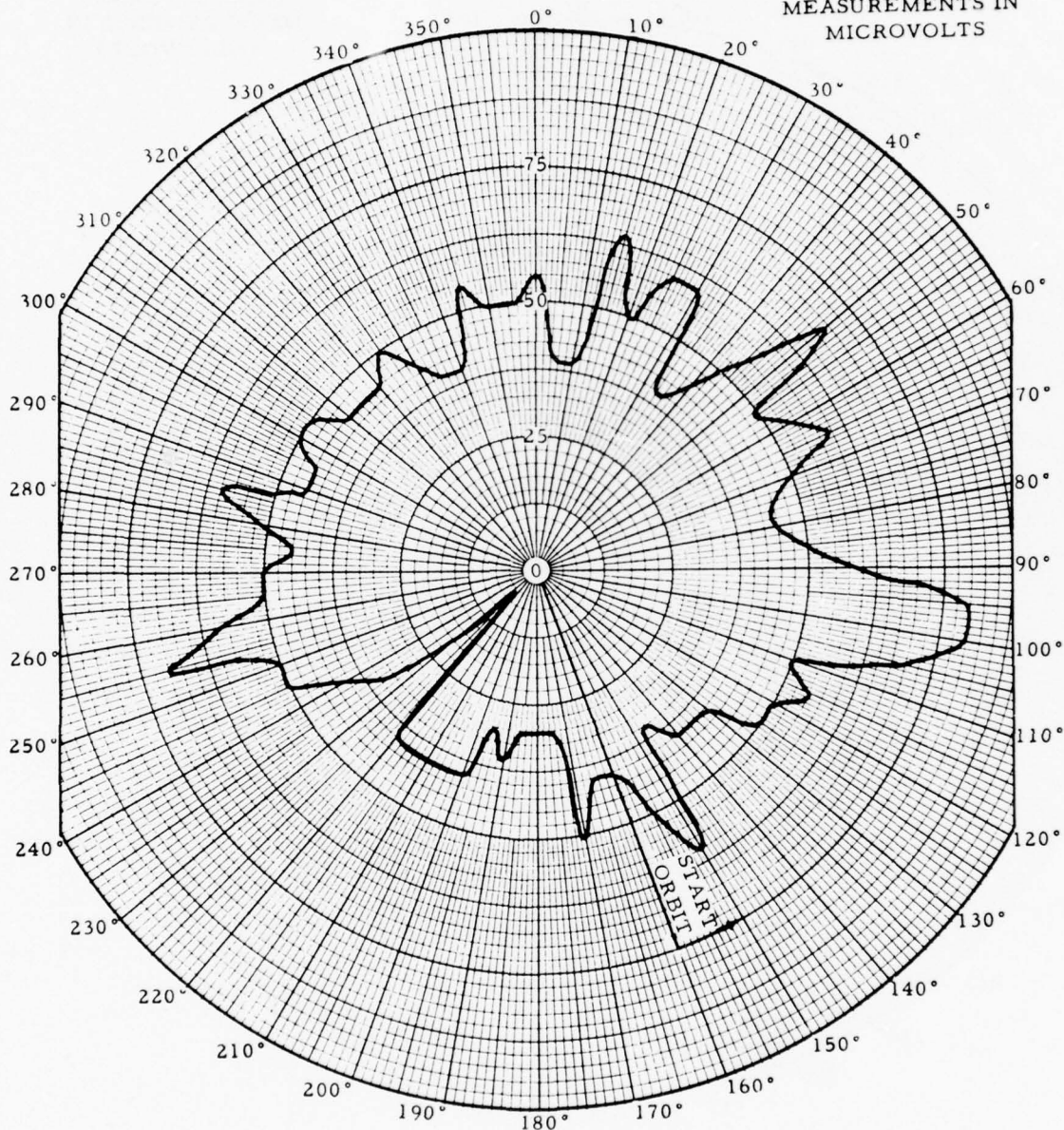

NOTE:

- 1 - GROUND ANTENNA: UHF ANTENNA AT-197/GR
- 2 - CARRIER FREQUENCY: 300.0 Mc
- 3 - TRANSMITTER POWER OUT: 100 WATTS
- 4 - ORBITAL FLIGHT: 40 NAUTICAL MILES
COUNTERCLOCKWISE
- 5 - ALTITUDE: 15,000 FT.
- 6 - DATA REDUCED FROM ONE ORBITAL
FLIGHT CHECK

VHF HORIZONTAL PLANE ANTENNA RADIATION PATTERN

VALUES SHOWN ARE
FIELD INTENSITY
MEASUREMENTS IN
MICROVOLTS

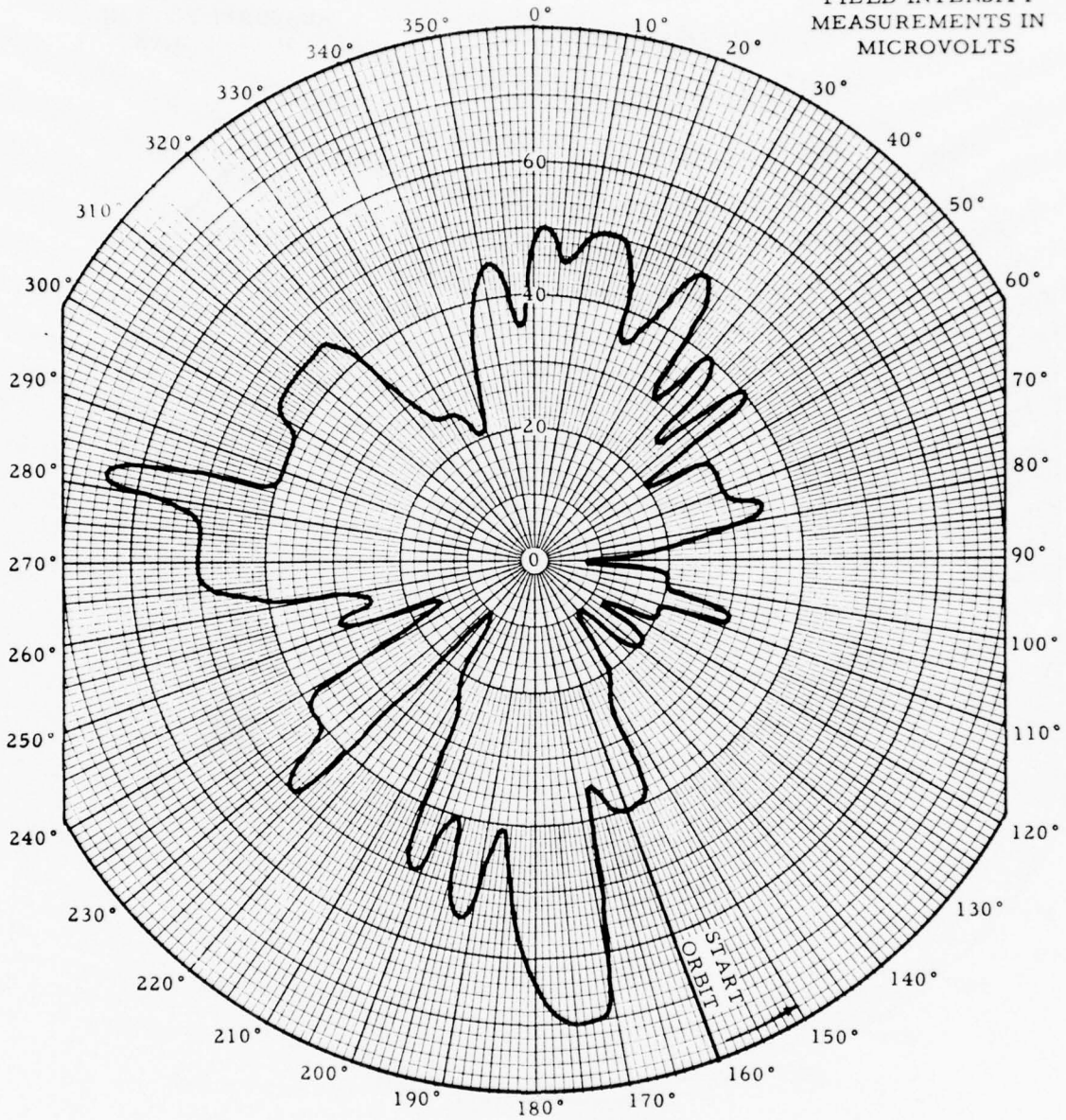

NOTE:

- 1 - GROUND ANTENNA: VHF ANTENNA CA-1781
- 2 - CARRIER FREQUENCY: 134.5 Mc
- 3 - TRANSMITTER POWER OUT: 50 WATTS
- 4 - ORBITAL FLIGHT: 40 NAUTICAL MILES
COUNTERCLOCKWISE
- 5 - ALTITUDE: 15,000 FT.
- 6 - DATA REDUCED FROM ONE ORBITAL
FLIGHT CHECK

receive at a given frequency. This antenna sharing configuration, shown in Exhibit 15-5, not only reduces the number of antennas but also the number of transmission lines. Although this arrangement requires a coaxial transmit-receive (TR) switch, present-day technology is such that coaxial switches are available with a life in excess of 20 million operations, an isolation of about 75 dB, and an insertion loss less than 0.5 dB. Switch reliability, therefore, is no longer a significant problem.

These switches would normally be mounted inside an equipment building (assuming collocation of transmitters and receivers) and controlled by the transmitter key line. Note that this arrangement also serves to disconnect unkeyed transmitters from their antennas, thereby disconnecting a possible source of IM generation from an antenna located in high RF fields. The receiver, which would be connected to the antenna except during transmission, has a front-end filter to help reject extraneous frequencies which might mix in the first active stages.

Other ways to reduce the number of antennas at typical sites involve active or passive multicouplers for connecting anywhere from two to sixteen receivers to a common receive antenna. In addition, multiplexers (either lossy or theoretically lossless) can be used for connecting two or more transmitters to a common transmit antenna. Diagrams for these arrangements are shown in Exhibits 15-6 and 15-7. It is noted that the active and passive multicouplers are existing equipment designs for both VHF and UHF.

The insertion loss of the passive multicouplers is usually about 0.5 to 1.0 dB above the power division loss. Due to the power division loss (9 dB for an eight-port divider), the system noise figure can be drastically degraded with passive multicouplers. Active multicouplers help overcome this power division loss with an amplifier. Typical active multicouplers have a net gain of 0 to +3 dB and a noise figure of about 7 dB. The disadvantage of using active multicouplers is that high-level ambient RF signals, such as those at common TR sites, can produce IM products in the amplifier.

Exhibit 15-5

VHF TRANSCEIVER CONFIGURATION

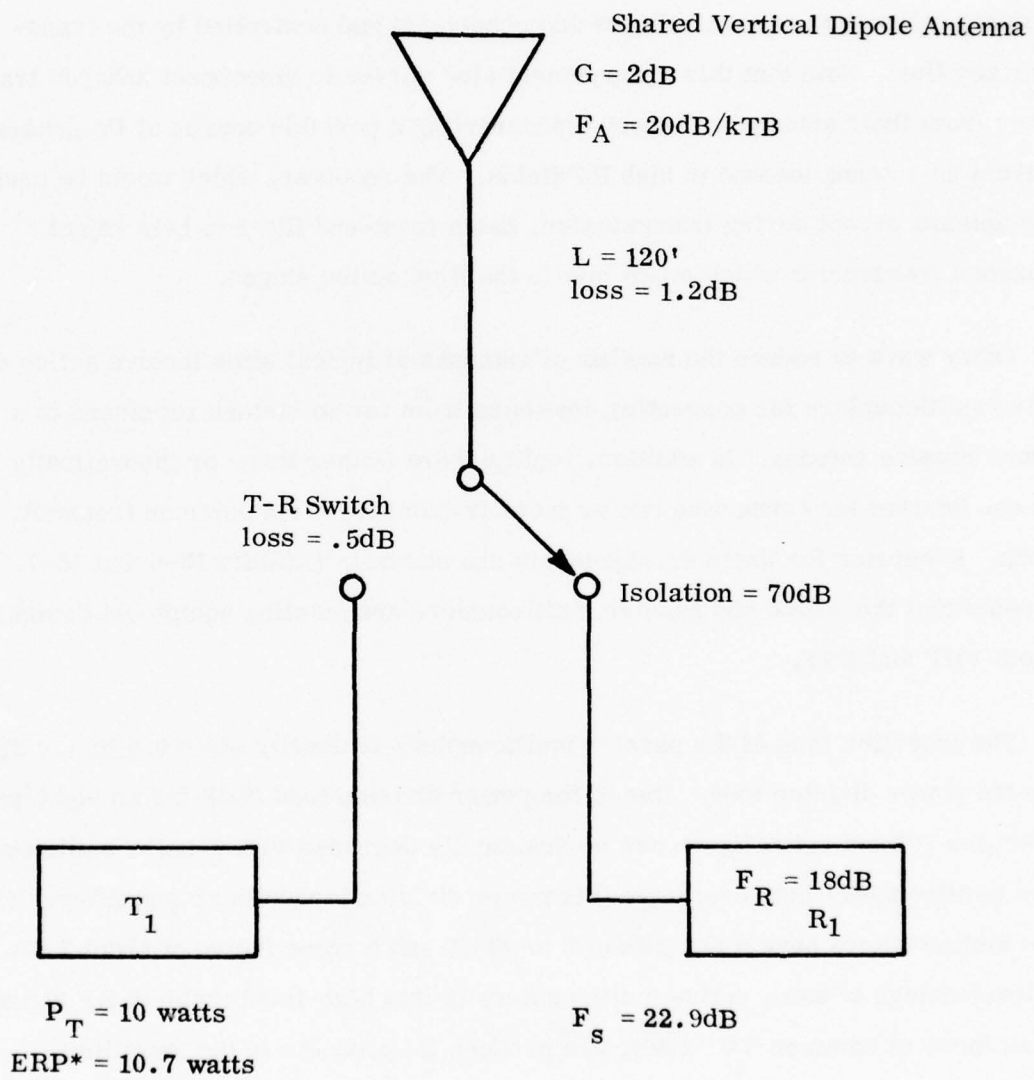

*ERP = $P_T G_T L_{TL}$

VHF RECEIVER CONFIGURATION

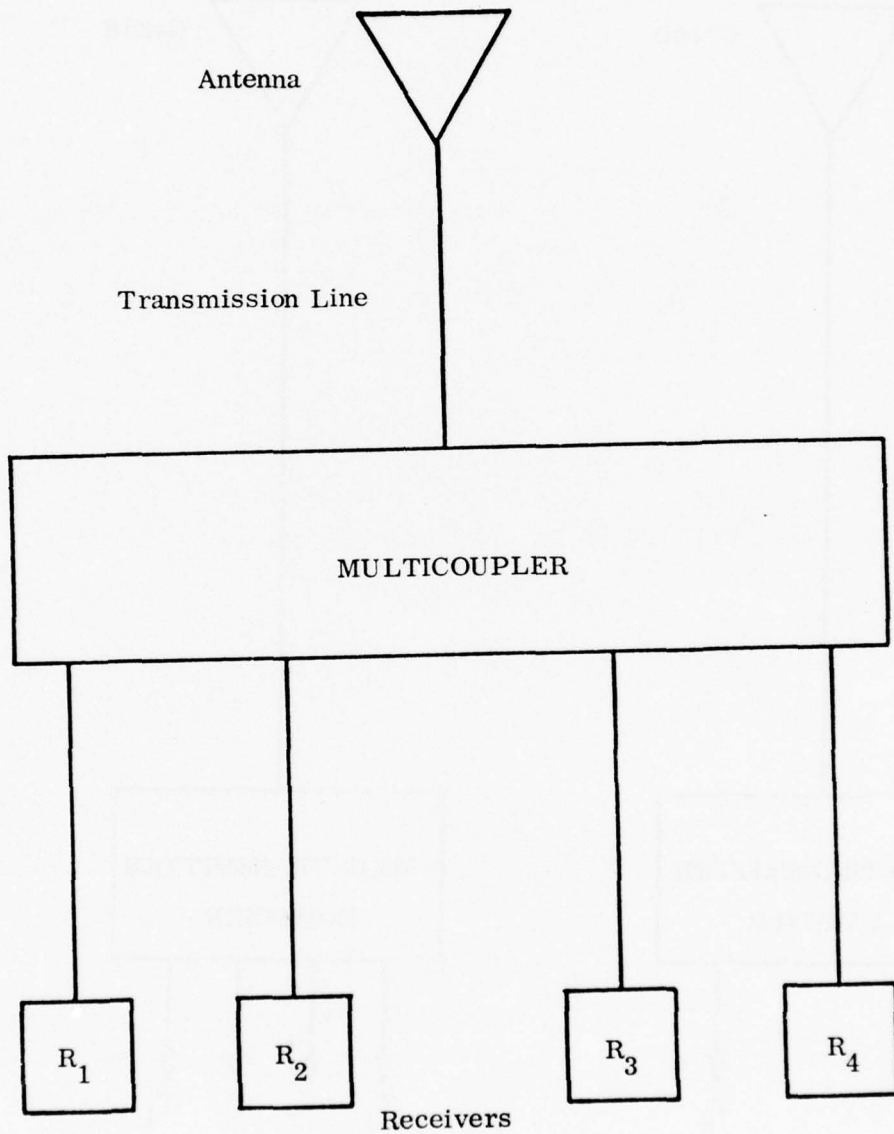
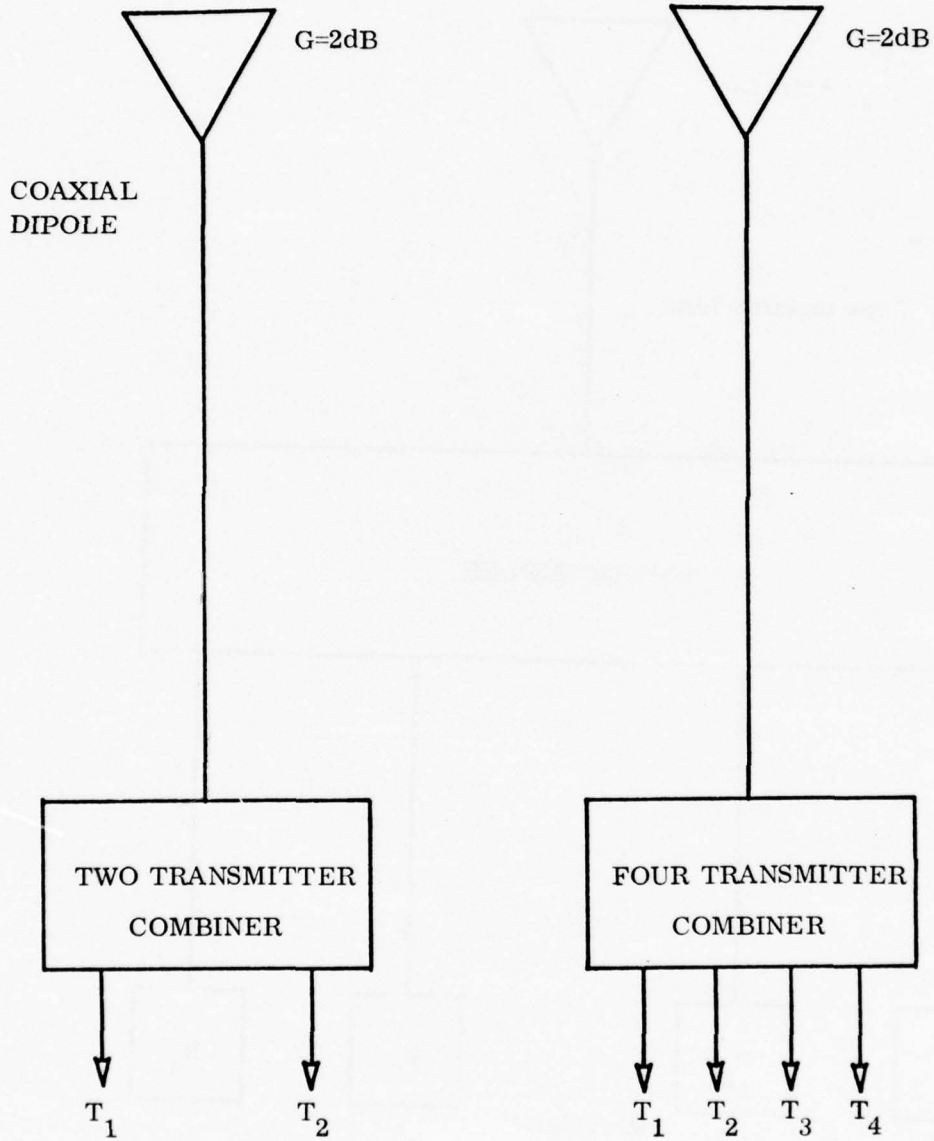

Exhibit 15-7

TWO AND FOUR PORT TRANSMITTER COMBINERS



One possible multicoupler for UHF transmitters is a two-channel tunable unit made by Collins Radio Company (CU-692/U). This unit can couple two transmitters to a common antenna with more than 60 dB isolation (assuming more than 4 MHz channel spacing). The manually tuned CU-691/U four-channel coupler could also be used if required.

At VHF, a lossless multiplexer of this type is not a standard design. The design of a theoretically lossless multicoupler at VHF, however, is well within the state of the art. An estimated size for a four channel unit is less than 4' x 3' x 3'. The electrical characteristics would be about the same as the UHF unit except for the minimal channel separation required to obtain 60 dB or more of isolation.

An alternate approach for combining UHF transmitters is to use combinations of 3 dB couplers, isolators, and dummy loads, in the arrangement shown in Exhibit 15-8. With this approach, about half of the available power from each transmitter is dissipated with each combiner (3 dB coupler and dummy load). Isolators must be used to minimize internal (IM) problems between the transmitters being combined. A combiner for four transmitters would typically have about 8.5 dB loss and it could supply about 70 dB of isolation at close frequency spacings. Since part of the power is dissipated, it may be necessary to use 50 watt transmitters instead of 10 watt transmitters to achieve the same effective radiated power (ERP) at low altitudes. For high altitude coverage, where 50 watt transmitters are already required, the loss could be minimized by combining as few transmitters as possible into one antenna. The lossy combiner approach is not recommended as a standard equipment configuration, mainly due to the loss which needs to be made up with power amplifiers.

Receiving multicouplers at VHF offer the same advantages and disadvantages as the corresponding receive configurations at UHF. Since it is desirable to minimize losses between the antennas and the receivers so as to minimize the system noise figure at both frequency bands, the use of 7/8" diameter FOAM-Flex cable for UHF and 1/2 " diameter FOAM-Flex cable for VHF is recommended.

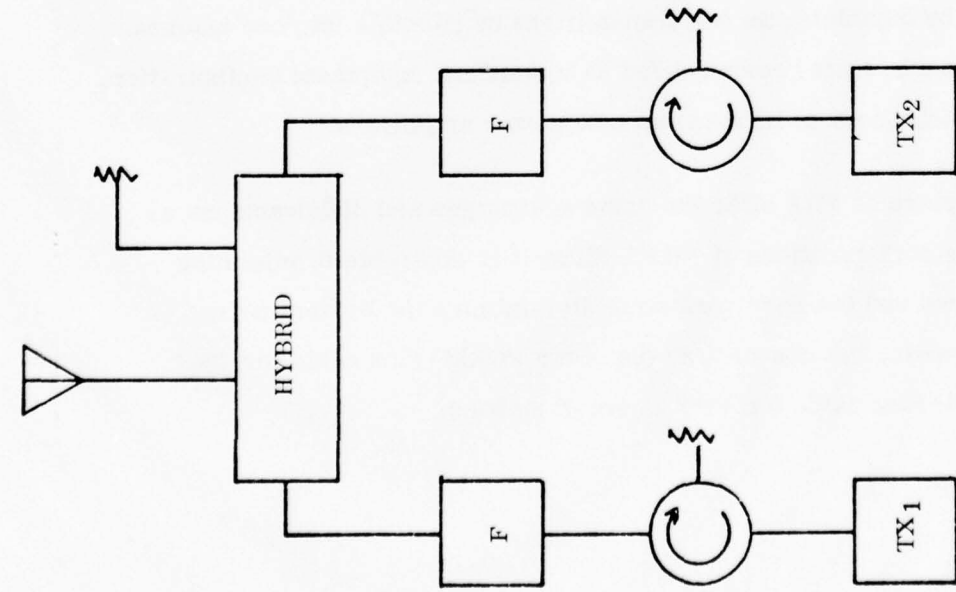

2 TRANSMITTER
INSERTION LOSS 4 dB
PER CHANNEL

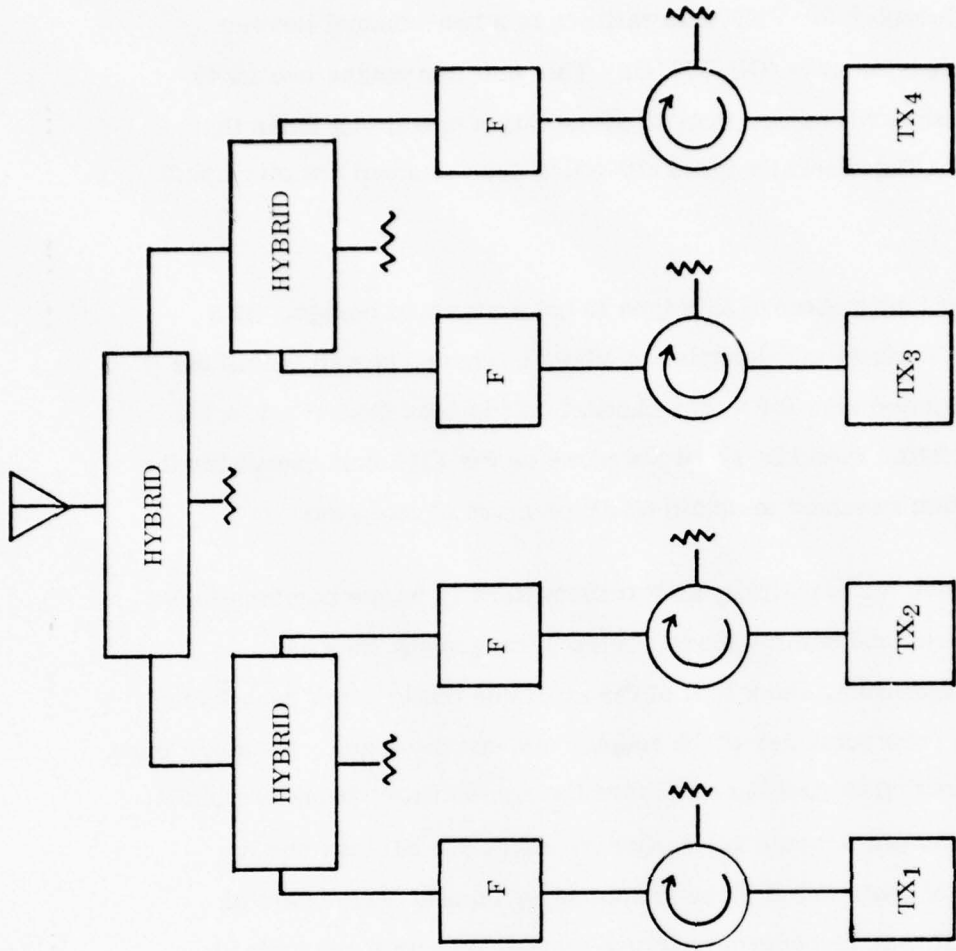

4 TRANSMITTER COMBINER
INSERTION LOSS 7.5 dB PER CHANNEL

KEY





	=	HARMONIC FILTER
	=	ISOLATOR
	=	50 OHM LOAD
	=	ANTENNA

Exhibit 15-8 TRANSMITTER COMBINER CONFIGURATIONS

For transmit, it is desirable to maximize the effective radiated power (ERP). This is also accomplished by minimizing the losses between the transmitters and the antennas by using a larger diameter coaxial cable than the 1/2" flexible (RG-8) cable presently being used at some installations. The ERP can be further increased at UHF (or system losses counteracted) by using a 6 dB gain colinear UHF antenna array (several suitable products are available) instead of the 2 dB gain antenna currently being used.

By employing the above combining techniques, the antenna siting at RCAG sites (see Exhibit 15-9) can be improved (see Exhibit 15-10).

In summary, the following recommendations will aid in improving site installations:

VHF

- ELIMINATE SWASTIKA ANTENNAS
- USE 1/2" FOAMFLEX TRANSMISSION LINE
- USE SINGLE ANTENNA AND T-R SWITCH FOR EACH FREQUENCY
- USE ACTIVE MULTICOUPLERS FOR REMOTE RECEIVE (R-R) SITES

UHF

- USE 6 dB GAIN OMNIDIRECTIONAL ANTENNAS
- USE T-R SWITCHES
- USE 7/8" FOAMFLEX TRANSMISSION LINE
- USE 2 OR 4 CHANNEL MANUALLY TUNABLE MULTICOUPLERS WHEN REQUIRED

Exhibit 15-9

EXISTING RCAG ANTENNA TOWER CONFIGURATION

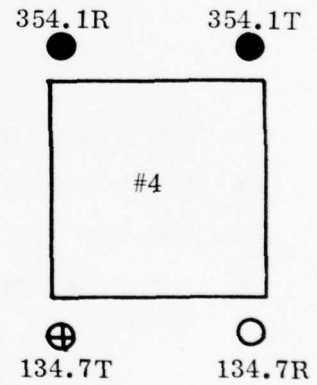
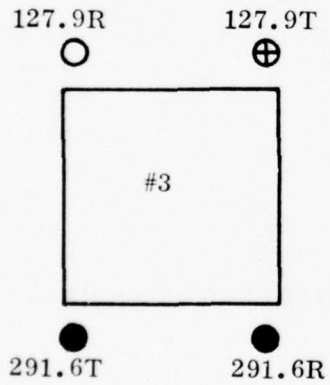
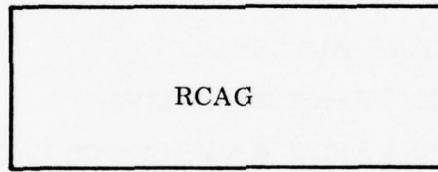
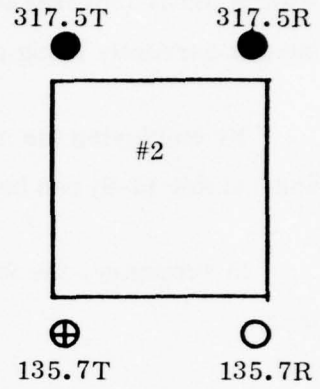
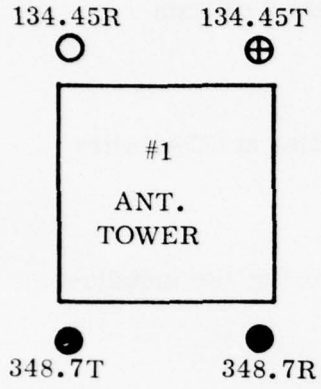

- ⊕ VHF SWASTIKA
- VHF COAXIAL
- UHF AT-197

Exhibit 15-10

MODIFIED RCAG SITE CONFIGURATION

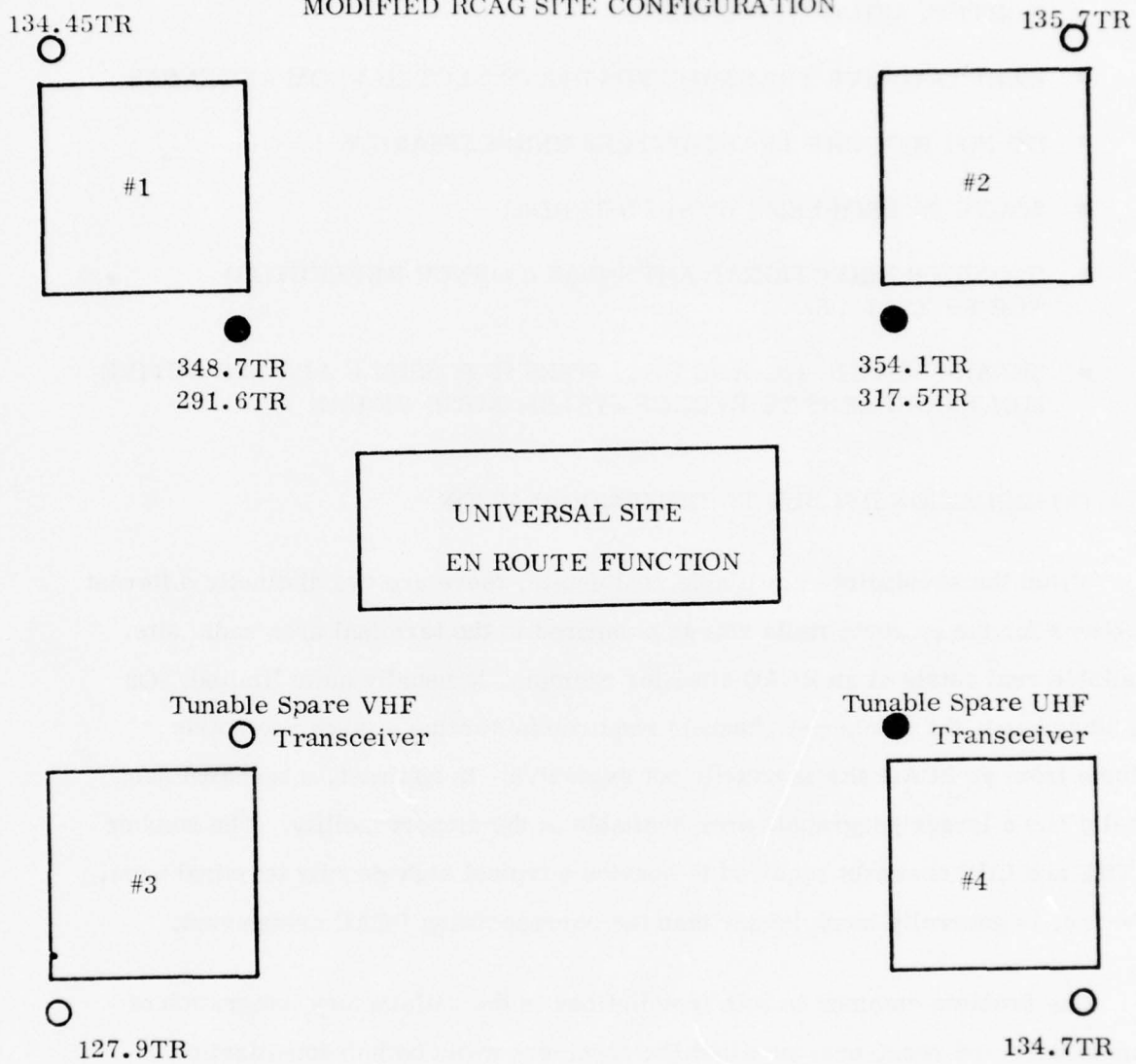

○ VHF COAXIAL
● UHF 6dB GAIN

CURRENT: 4 SWASTIKAS
4 COAXIAL
8 UHF

NEW: 0 SWASTIKAS
5 COAXIAL
2 UHF (6dB)
1 UHF (2dB)

TOTALS 16

8

GENERAL

- ENGINEER ANTENNA PLACEMENT TO MINIMIZE PATTERN DISTORTION AND INTERFERENCE
- KEEP INACTIVE TRANSMITTERS DISCONNECTED FROM ANTENNAS
- DO NOT KEY UHF TRANSMITTERS UNNECESSARILY
- SOLVE IM PROBLEMS WITH FILTERING
- CONSIDER DIRECTIONAL ANTENNAS (CORNER REFLECTOR) FOR SPECIAL USE
- SEPARATE VHF TX. AND REC. SITES IF POSSIBLE AND USE ACTIVE MULTICOUPLERS TO REDUCE SYSTEM NOISE FIGURE

15.3 CO-LOCATION RFI DUE TO INTERMODULATION

From the standpoint of available real estate, there are two distinctly different problems for the en route radio site as compared to the terminal area radio site. Available real estate at an RCAG site, for example, is usually quite limited. On the other hand, the number of channels required to service a given geometric volume from an RCAG site is usually not excessive. In contrast, a terminal area usually has a larger geographic area available at the airport facility. The number of VHF and UHF channels required to service a typical high-density terminal area, however, is generally much larger than the corresponding RCAG assignment.

One problem common to both installations is the satisfactory integration of transmitters and receivers, such that the receivers avoid both desensitization due to proximity of a medium-powered transmitter and direct co-channel interference resulting from intermodulation products which can occur by a mixing action of two or more transmitted signals in a non-linear device. The purpose of the following paragraphs is to discuss the nature of this radio frequency interference (RFI) in terms of the transmit power level, the mixer mechanism and spacing between the transmitters and receivers. The results will then be related to general site layout considerations.

15.3.1 IM Products Due to Co-located Transmitters

The collocation of communication transmitters with sensitive receivers at a common site frequently results in radio frequency interference caused by the generation of spurious intermodulation products in some non-linear device located near the transmitters and receivers. These spurious frequencies result from the mixing of two or more transmitter frequencies with each other to produce a frequency within the passband of some third receiver in the general area. Of concern in the design of a given transmitter/receiver site are the types of intermodulation products generated, their quantity, and the resulting interference level.

The intermodulation interference problem is formulated with the aid of Exhibit 15-11. This figure shows two transmitters, T_1 and T_2 , connected to separate antennas. Each of these antennas are separated by distances R_1 and R_3 from a third antenna, which is connected to a diode mixer. This third antenna might be an actual antenna or a tower segment. The diode mixer might be either a non-linear device in the final amplifier of one of the on-site VHF or UHF transmitters, or it might be a corroded portion of a tower or other metallic structure in the area which acts as a semiconductor.

When signals are transmitted from T_1 and T_2 through their respective antenna systems, A_1 and A_2 , toward the antenna system associated with the diode mixer, A_3 , they encounter a space loss corresponding to their separation from A_3 . Once mixing has occurred in the diode, the mixer products are re-radiated from A_3 to another antenna (A_4) which is, in turn, connected to a receiver tuned to some different frequency. This process involves an additional space loss factor associated with the physical separation, R_2 . Each of these distances, R_1 , R_2 , and R_3 , results in a space loss factor given by equation (1).

$$L_{FS} \text{ (dB)} = 22 \text{ (dB)} + 20 \log (R/\lambda) \quad (1)$$

TO
RECEIVER
SITE

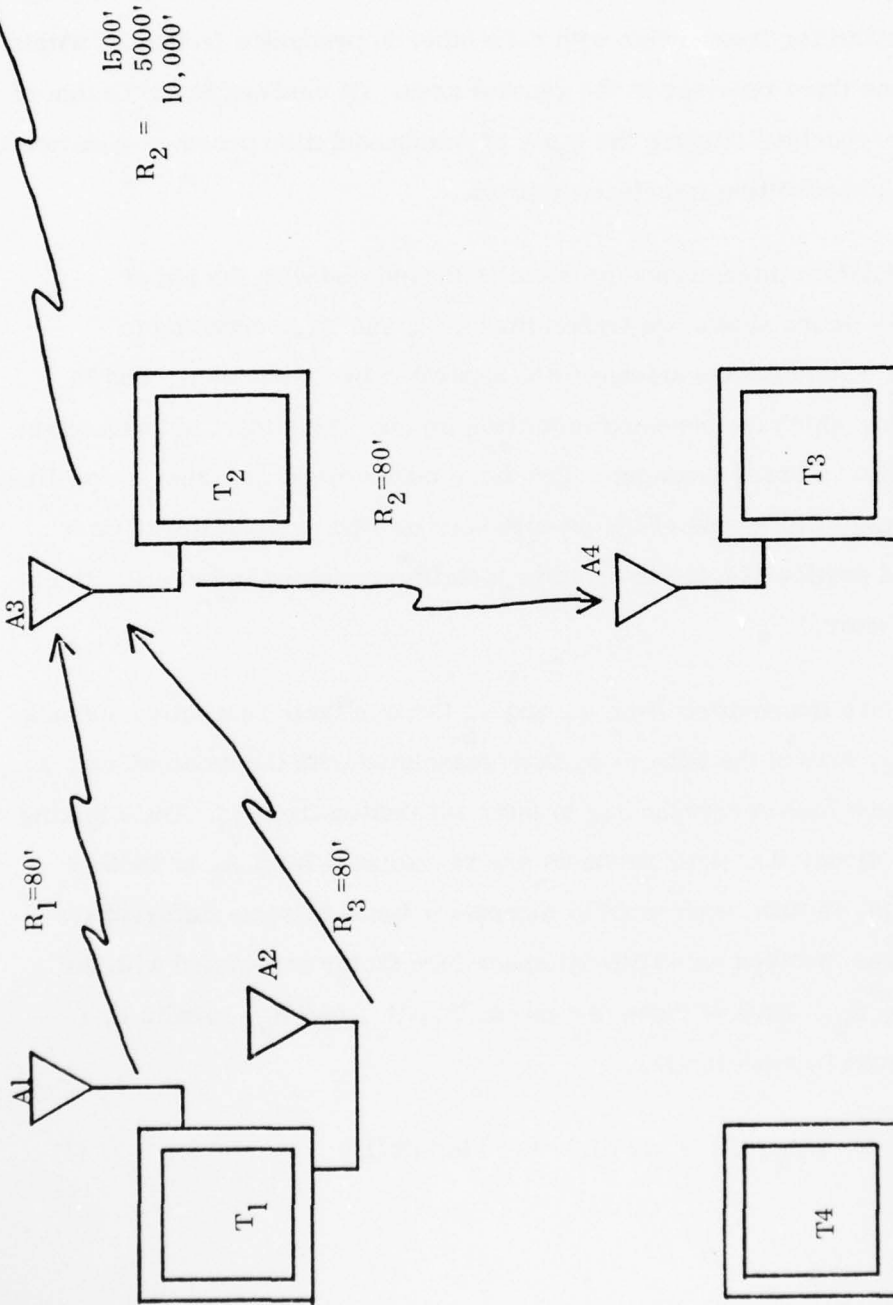

Exhibit 15-11

POSSIBLE IM GENERATING
GEOMETRY - 2ND OR 3RD
ORDER PRODUCTS

For the purposes of this analysis, it will be assumed that $R_1 = R_3 = 80$ feet, and that T_1 and T_2 are connected to antennas which share a common tower. In addition, R_2 will assume the values of 80 feet, 1500 feet, 5000 feet, and 10,000 feet. The intermodulation level at the desired receive site R_4 can be calculated from equation (2).

$$P_{IM} = P_T - L_p - L_c + G_1 G_2 G_4 - L_S \quad (2)$$

Where:

P_T = transmit power,

L_p = total propagation loss from the transmitter to the diode mixer,

L_c = the effective mixer conversion loss,

G_1, G_3, G_4 = antenna gains associated with their respective antennas,

L_S = the system transmission losses from the transmitters through the antennas and free space to the receivers.

When expressed in dB, this equation becomes equation (3).

$$P_{IM} = P_T(\text{dBm}) - 44 \text{ dB} - 20 \log(R_1/\lambda) - 20 \log(R_2/\lambda) - L_c(\text{dB}) + 10 \log(G_1 G_2 G_3) - L_S(\text{dB}) \quad (3)$$

One simplifying assumption is to assume that the antenna gain term approximately equals the system $\frac{2}{R}$ loss, so that the latter two terms can be deleted.

The conversion loss due to the mixing process in the diode can now be calculated using the equations developed by Steiner.¹ Steiner's general equation gives the intermodulation product level amplitude in terms of dB above or below a reference level equal to the total mixer input power. Steiner's equation contains three terms, one of which is a fixed conversion loss. The other two depend on the input power level of the various signal sources. If it is assumed that all transmitters radiate

1. James W. Steiner, "An Analysis of Radio Frequency Interference Due to Mixer Intermodulation Products," IEEE Transactions on Electromagnetic Compatibility, January 1964, pp. 62-68.

essentially equal power levels, so that the interference generating frequencies arrive at the mixer at approximately the same level, then the conversion loss, L_c , is given by the two terms of equation (4).

$$L_c = 10 (N) \times \log (n) \quad (4)$$

In this equation N refers to the product order and n refers to the number of frequencies. The fixed conversion loss, L_c , was tabulated in Steiner's article. The calculated results of equation (4) are indicated in Exhibit 15-12 (and summarized in Exhibit 15-13) for product orders 2, 3, and 5. It is seen that the conversion loss increases significantly with the product order.

The resulting internal levels can now be calculated from equation (3) for $P_T = +47$ dBm (50 watt transmitter) or +40 dBm (10 watt transmitter). The corresponding intermodulation levels at the receiver are tabulated in Exhibit 15-14. From this exhibit it is seen that the fifth order products at 1,500 feet are -105.5 dBm and -112.5 dBm, depending on the transmit power level. Since these levels are below the desired receiver sensitivity of -103 dBm, they can be neglected at this range and beyond. However, it is noted that the third order products are at a level of -82.5 dBm or -89.5 dBm, depending on the input power level. This means that third order products can be expected to interfere at the 1,500-foot range. At 5,000 feet, the third order product is -100 dBm for a 10 watt transmitter, whereas a 50 watt transmitter results in a -99 dBm third order product level at a range of 10,000 feet. It is noted that this table is calculated for the worst case problem which exists at VHF. Due to higher free space attenuation at UHF, the resulting IM level at the quoted separations would be lower.

The approximate levels expected from third and fifth order intermodulation products can be employed to derive the optimum arrangement of transmitters and receivers for a given amount of real estate. The solution is partially a function of the number of products generated.

Exhibit 15-12

MIXER CONVERSION LOSSES*

PRODUCT ORDER	IM TYPE	FIXED LEVEL LOSS (dB)	10 x N x log(n) (dB)	TOTAL L _c (dB)
2	A ± B	3.6	6	9.6
	2A			--
3	A ± B ± C	5.3	14.3	19.6
	2A ± B	11.3	9	20.3
	3A	20.9		
5	A ± B ± C ± D ± E	6.8	35	41.8
	2A ± B ± C ± D	12.8	30.1	42.8
	2A ± 2B ± C	18.8	24	42.8
	3A ± B ± C	22.4		
	3A ± 2B	28.4	15	43.4
	4A ± B	34.4		
	5A	48.4		

* See James W. Steiner, "An Analysis of Radio Frequency Interference Due to Mixer Intermodulation Products," IEEE Transactions on Electromagnetic Compatibility, January 1964, pp. 62-68.

Exhibit 15-13

TOTAL MIXER CONVERSION LOSS
AS A FUNCTION OF PRODUCT ORDER

<u>Product Order</u>	<u>L_c (dB)</u>
2	10
3	20
5	43

Exhibit 15-14

IM PRODUCT LEVEL AS A FUNCTION OF SITE GEOMETRY

<u>Transmit Level</u> <u>P_T (dBm)</u>	<u>Conv. Loss</u> <u>L_c (dB)</u>	<u>Received IM Level (dBm) for:</u>			
		<u>R₂ = 80'</u>	<u>R₂ = 1500'</u>	<u>R₂ = 5000'</u>	<u>R₂ = 10,000'</u>
+40	10	-54 dBm	-79.5 dBm	90 dBm	-96 dB,
+40	20	-64	-89.5	100	-106
+40	43	-87	-112.5	123	-129
+47	10	-44	-72.5	83	-89
+47	20	-57	-82.5	93	-99
+47	43	-80	-105.5	116	-122

The severity of the problem will first be illustrated with a simple case which shows the number of second and third order intermodulation products occurring in the VHF and UHF frequency bands. The equations for the second and third order VHF products are given in Exhibit 15-15. In this exhibit u_i or u_j refers to any given UHF frequency, whereas v_i and v_j refer to any VHF frequency. It is noted that products can be generated by the interaction of VHF frequencies with other VHF frequencies, between UHF frequencies, or between UHF and VHF frequencies. Corresponding products for the UHF band can also be generated in the same manner.

If 15 VHF frequencies are assumed operating in conjunction with 11 UHF frequencies, the number of combinations increases significantly to a total of 2455 products in the UHF band, as shown in Exhibit 15-16. It is noted that the addition of 1 UHF frequency and 1 VHF frequency at a site possibly provides as many as 3S more second and third order intermodulation products at VHF, where S is the total number of VHF transmitters existing before.

A less common form of intermodulation interference is caused by the interaction of a local VHF or UHF transmitter and a broadcast FM transmitter in close proximity to either an RCAG facility or an airport facility. The mechanism involved in the generation of products of this nature is the same as that involved in collocated VHF and UHF transmitters. Equations (5), (6), and (7) describe the manner in which possible intermodulation interference is formed. Equation (5) represents the interaction of a second harmonic of a local VHF frequency with a broadcast FM frequency to produce an interfering product at some other VHF frequency. Equation (6) shows the interaction between a UHF frequency and a broadcast FM frequency to produce a product at some other VHF frequency. Equation (7) shows the interaction of the UHF frequency with a broadcast FM frequency to produce a product at a second UHF frequency. In these equations, the term $\pm\Delta f$ refers to the broadcast frequency having a bandwidth 2 times Δf . Examples of these three cases are shown directly beneath the corresponding equations.

$$2V_1 - (\text{FM } \pm\Delta f) = V_2 \quad (5)$$

$$\text{Example: } 2(118) - (106 \pm \Delta f) = 130 \text{ MHz}$$

Exhibit 15-15: SECOND AND THIRD ORDER IM PRODUCTS AT VHF

<u>Order</u>	<u>Mode</u>	<u>Combinations</u>
2	$u_i - v_j$	$\sum_{j,i}^{UV} u_i - v_j = UV$
2	$v_i - v_j$	$\sum_{i,j}^V v_i - v_j = C_2^V$
3	$2v_i - v_j$	$\left. \begin{array}{l} \sum_{i,j}^V 2v_i - v_j \\ \sum_{i,j}^V 2v_j - v_i \end{array} \right\} = 2C_2^V$
	$2v_i - v_j$	
3	$v_i + v_j - v_k$	$\sum_{i,j,k}^V v_i + v_j - v_k = C_2^V (V-2)$

where $C_2^V = \frac{V!}{2!(V-2)!}$

TOTAL IMs for 6 U's and 6 V's

$T_6 = 36 + 15 + 30 + 60 = \boxed{141}$

for 5 U's and 5 V's

$T_5 = 25 + 10 + 20 + 30 = \boxed{85}$

Exhibit 15-16

SECOND AND THIRD ORDER IM PRODUCTS AT UHF

<u>Order</u>		<u>Possible Combinations*</u>
3	$v_i + v_j + v_k$	455
2	$2 \times v_i$	30
2	$v_i + v_j$	105
3	$2 \times u_i - u_j$	110
3	$2 \times u_i - v_j$	165
3	$2 \times v_i - v_j$	210
3	$v_i + v_j - v_k$	1365
3	$3 \times v_i$	<u>15</u>
	TOTAL:	2455

*
 For 15 VHF frequencies and 11 UHF frequencies
 (typical of Oakland Terminal Area).

$$U_1 - (FM \pm \Delta f) = V_1 \quad (6)$$

Example: 225 - 100 = 125 MHz

$$U_1 - (FM \pm \Delta f) = U_2 \quad (7)$$

Example: 350 - 100 = 250 MHz

where $FM \pm \Delta f = \Delta FM$ broadcast frequency of
bandwidth $2f$

The level of the products produced due to the interaction of the frequencies indicated can be estimated. Broadcast FM transmitters have an effective radiated power (the product of the actual transmitter power times the antenna gain) of levels on the order of 50 kilowatts. Most of this power is radiated as horizontally polarized. In recent years a substantial vertical component has been radiated due to a large number of FM receivers now available as automobile radios. A reasonable value for the vertically polarized component from a maximum power FM station is 10,000 watts ERP. If a station having this power capability is located within five miles of either an en route or a terminal facility, then the established field would be 100 dB below the 10,000 watt level. Thus, a received level of -30 dBm can be expected. As a result of other VHF and UHF transmitters in the vicinity of this non-linear device, other levels on the order of 0 dBm can be expected. It is seen that IM products can easily be formed with a resulting signal level well above that which can cause interference on a co-channel basis with receivers in the vicinity. Thus FM broadcast transmitters within close proximity to an air/ground radio facility should be considered in the frequency management plan for the site.

15.3.2 Separate Transmit/Receive Sites vs. Combined Sites

Now consider the case of operating 15 VHF transmitters and 11 UHF transmitters on one site with receivers located on a separate site some specified distance away, as shown in Exhibit 15-17. The number of second and third order products resulting from this configuration is shown in Exhibit 15-18.

Exhibit 15-17

SEPARATE vs. COMBINED RADIO SITES

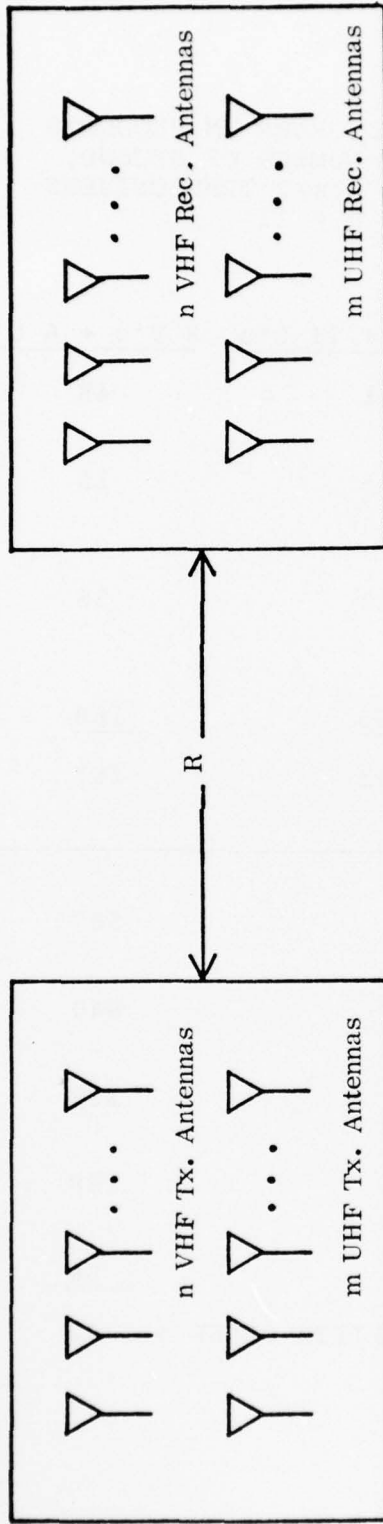

Separate Tx. and Rec. Sites (RT + RR)

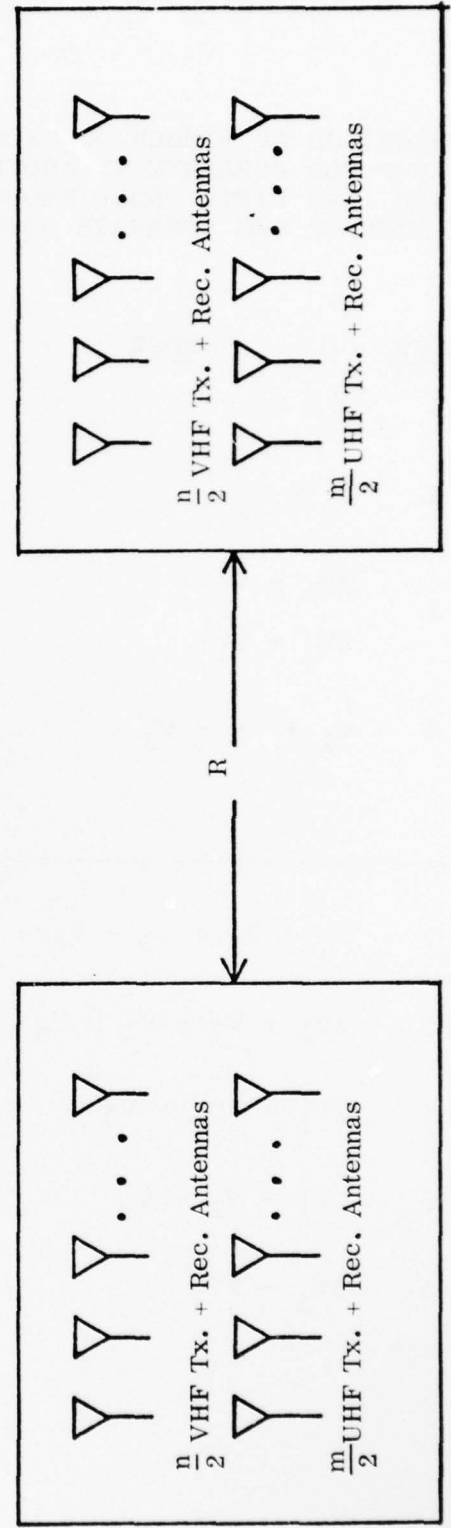

Mixed Tx. and Rec. Sites (RTR + RTR)

Exhibit 15-18

COMPARISON OF NUMBER OF SECOND AND THIRD ORDER IM PRODUCTS AT VHF FOR SEPARATE TX AND RX SITES VS. NUMBER OF SECOND, THIRD, AND FIFTH ORDER PRODUCTS FOR $n/2 + m/2$ TRANSCEIVERS AT EACH OF TWO SEPARATE SITES: $n = 15, m = 11$

<u>ORDER</u>	<u>MODE</u>	<u>15 V's + 11 U's</u>	<u>8 V's + 6 U's</u>
2	$U - V$	161	48
2	$U_1 - U_2$	55	15
3	$2V_1 - V_2$	210	56
	$2V_2 - V_1$		
3	$V_1 + V_2 - V_3$	<u>1365</u>	<u>168</u>
		1791	287
<hr/>			
5	$V_1 + V_2 + V_3 - V_4 - V_5$		560
5	$2V_1 + V_2 - V_3 - V_4$		840
5	$2V_1 - 2V_2 + V_3$		168
5	$3V_1 - V_2 - V_3$		168
5	$3V_1 - 2V_2$		<u>56</u>
		TOTAL FIFTH ORDER = 1792	

If the transmitter site is split into two separate transmitter sites (see Exhibit 15-17) separated by sufficient distance so that there is no interaction or generation of intermodulation products between the two sites, and assuming that one of the sites has 8 VHF transmitters and 6 UHF transmitters (more than half of the previous number), then the number of second and third order intermodulation products is reduced to 287 as compared to the previous 1,791 possible products.

If the fifth order products resulting from 8 VHF and 6 UHF transmitters are considered, then a similar technique can be used to estimate the possible number of fifth order products to be 1,792. If these transmitters are co-located with 8 VHF receivers and 6 UHF receivers, it is seen that a significant intermodulation product problem exists when the fifth order products are considered, but that this fifth order intermodulation problem is no worse than the previous case of 15 VHF transmitters and 11 UHF transmitters operating within the third order intermodulation product propagation range of the receivers.

15.3.3 Application to General Siting Considerations

The following generalizations can now be made.

- It is better to use two RTR sites than one RT and one RR site, unless 5,000-10,000 feet physical separation is available between the RT and the RR sites.
- The fifth order products at VHF are negligible beyond 1,500 feet separation between RT and RR sites.
- With separations less than 1,500 to 10,000 feet, care must be taken to avoid the generation of co-channel interference resulting from the third order intermodulation products.
- Within 1,500 feet separation, care must be taken to avoid interference resulting from the fifth order intermodulation products as well as the third order products.

- The number of both third and fifth order products generated is reduced if the transmit site is divided into two separate sites, with half the number of transmitters at one site and the other half at a second site.
- Split transmitter sites can probably be collocated with receive sites, because the total number of IM products, at close range (principally fifth order), is no worse than the number of third order products at 1,500 feet separation between separate transmit and receive sites.
- However, the probability of fifth order products being set up is much lower than third order products, because four or five transmitters are required to be operating simultaneously, versus two or three for third order products.

In summary, an effective approach to minimizing RFI due to intermodulation interference is to separate transmit and receive sites by 5,000 to 10,000 feet or, if this is not possible, to use separate RTR sites, with each having approximately half of the total number of required transmitters. These split sites should be located with at least 1,500 feet separation.

Since third order co-channel IM products can cause interference at a remote receive site even as much as 5,000 feet away from a transmitter site, these third order interference products should be avoided through proper frequency management. Neither adjacent channel third order products nor co-channel fifth order products are a problem at this range.

Third order adjacent channel products ($F_0 \pm 50$ kHz) are marginally a problem at sites having 80 feet tower spacing. Intermodulation products spaced at ($F_0 \pm 25$ kHz) are definitely a problem, as are co-channel second, third, and fifth order IM products. One solution is to keep third order IM products greater than 50 kHz away from F_0 and second order products greater than 100 kHz away.

AD-A042 514

VERVE RESEARCH CORP ROCKVILLE MD
STUDY REQUIREMENTS FOR AN INTEGRATED AIR/GROUND COMMUNICATIONS --ETC(U)
MAY 77 J HANSEN, A WEBSTER, B REYNOLDS

F/G 17/2.1

DOT-FA75 WAI-570

UNCLASSIFIED

VS-29

FAA-RD-76-154

NL

4 OF 4

AD
A042514

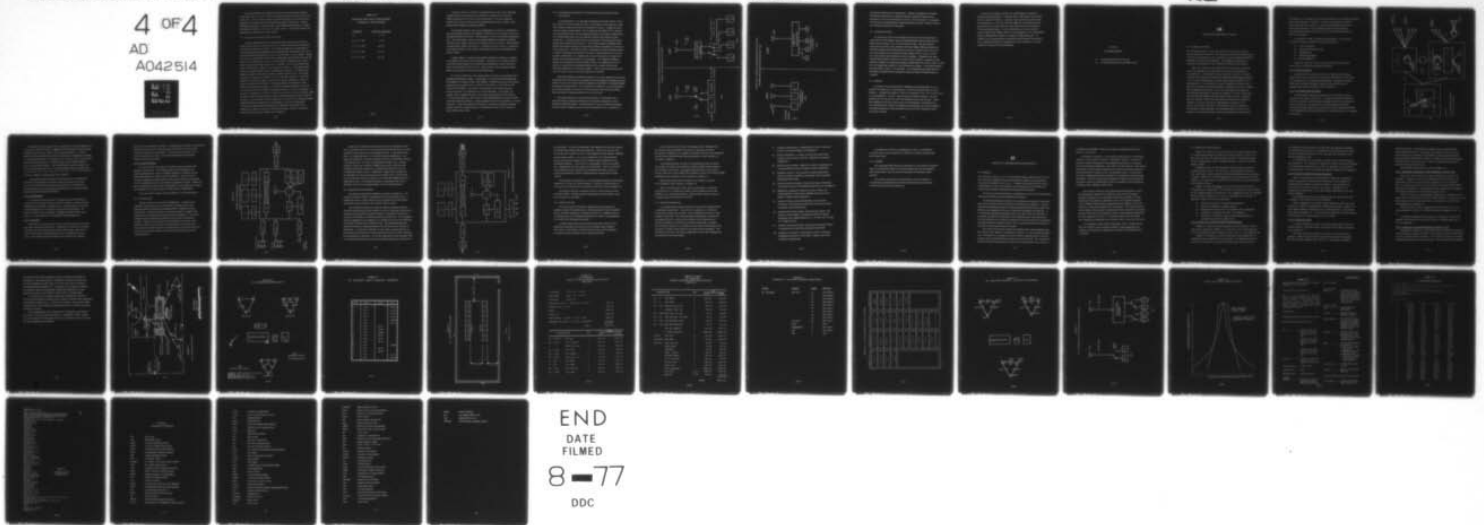

END
DATE
FILMED

8-77

DDC

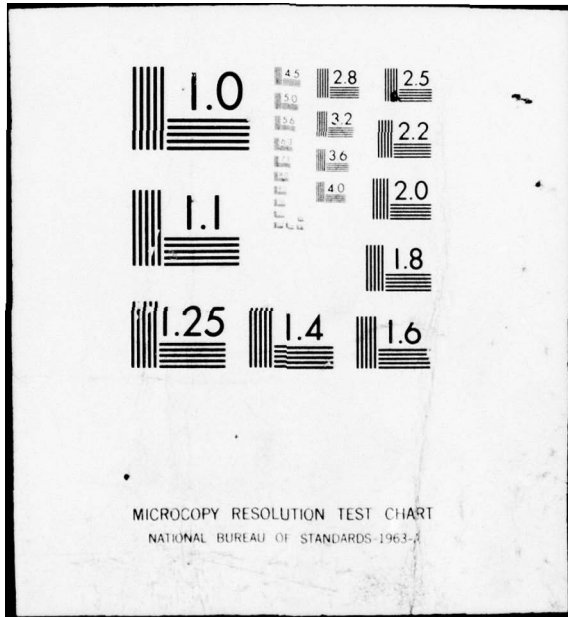

MICROCOPY RESOLUTION TEST CHART
NATIONAL BUREAU OF STANDARDS-1963-A

It is generally better to configure the site with one half the number of transmitters and receivers at one site and the remaining transmitters and receivers at the second site. This is because frequency management problems involving interfering frequencies are usually easier if the number of products is minimized. A further advantage to having two or more RT sites is that desensitization problems resulting from adjacent channel overload are more easily avoided. This adjacent channel overload problem is considered in a later section.

15.4 RECEIVER DESENSITIZATION PROBLEMS

Receiver desensitization due to adjacent channel overload rarely becomes a problem if the solid state receiver can meet its +7 dBm desensitization specification at a frequency separation of 200 kHz. The +7 dBm specification was apparently derived by considering the possibility that an interfering VHF transmitter located on an adjacent channel could typically be as close as 80 feet from a receive antenna. Specifically, the FAA specification requires that an interfering signal 200 kHz away from the desired receive signal and at a level of +7 dBm should not desensitize the receiver when it is receiving a desired signal level of -99 dBm. In order to accomplish this degree of interference rejection a front end filter is required. Good design practice dictates a four pole network having a 3 dB bandwidth of 200 kHz. The approximate frequency response of this front end filter is shown in Exhibit 15-19. This exhibit shows that at a frequency separation of 500 kHz, the filter response is -39 dB with respect to the midband response, whereas at a frequency separation of 1 MHz, the frequency response is 66 dB down. Considering only the characteristics of this filter as desensitization protection, it is seen that frequency separations of 500 kHz provide more than 20 dB of additional attenuation relative to a 200 kHz separation. If the nearby transmitter is 1 MHz or more away from the desired receive frequency, then the front end filter provides at least 50 dB of additional attenuation relative to the 200 kHz point. This means that if 80 feet separation is satisfactory for an adjacent channel located 200 kHz from the desired receive frequency, then an 8-foot separation (20 dB less isolation) would be acceptable for a separation between the receive antenna and an interfering transmit antenna if the transmit frequency is located at least 1 MHz away from the desired receive frequency.

Exhibit 15-19

ESTIMATED FRONT END FILTER RESPONSE
ASSUMING A 4-POLE NETWORK

<u>Frequency</u>	<u>Relative Response</u>
f_0	0 dB
$f_0 \pm 0.1 \text{ MHz}$	-3 dB
$f_0 \pm 0.3 \text{ MHz}$	-20 dB
$f_0 \pm 0.5 \text{ MHz}$	-39 dB
$f_0 \pm 1.0 \text{ MHz}$	-66 dB

The above analysis is important because the front end filter in the solid state equipment helps avoid desensitization problems in a multisignal environment. Judicious placement of the transmit antennas (and their associated frequencies) relative to the receive antennas (and their associated frequencies) is basic to both siting and the frequency management problem.

The methods outlined in the previous paragraphs are effective in solving potential intermodulation interference problems. There are other techniques, however, for dealing with these type problems. One technique is to use an interference cancellation unit. This unit samples a portion of the transmit signals and adjusts the amplitude and phase of this signal to cancel that received by the receive antenna. This technique is unnecessarily complex and sensitive. In addition, this type of device is directed at removing the symptoms of the problem rather than curing the intermodulation interference directly.

Another method of avoiding intermodulation interference problems is to utilize cavity filters at the output of each transmitter. The purpose of such filters would be to prevent external signals from reaching the final output power stage of the transmitter where possible mixing can occur. Note, however, that the purpose of these filters is not necessarily to purify the transmitted signal.

It is recommended that a more detailed study be conducted concerning the intermodulation interference problem. In particular, it is recommended that techniques be developed for locating sources of this problem. Although theories as to the sources range from the transmitter power amplifier to loose joints or rusty bolts in close proximity to the antenna, the nonlinear devices which most probably cause this problem in typical FAA installations are yet to be identified. It is possible, for example, that, as antenna elements in the system age and undergo shock vibration or corrosive atmospheres, a site formerly free of intermodulation interference might very well develop new problems. Another potential source of these problems is coaxial connectors. It has been found that connectors are sometimes improperly installed, with the result that a nonlinear device is obtained at the junction of the coaxial connector and the coaxial cable.

15.5 RECOMMENDED EQUIPMENT CONFIGURATIONS FOR SPECIFIC SITE/ GEOMETRIES

As mentioned above, it is desirable to eliminate the swastika antenna, which has a gain of -0.8 dB, and replace it with a vertical dipole having a gain of $+2.2$ dB. Since identical antennas can be used for transmit and receive, a single unit can be shared by using a coaxial transfer relay as illustrated in Exhibit 15-20. Portion A of this exhibit shows one of the recommended standard VHF modular configurations. The vertical dipole antenna is fed by half-inch-diameter foam dielectric transmission line. A fail-safe coaxial relay is recommended, with the normally closed position being connected to the receiver. Only a minor amount of additional transmission line should be required to connect the individual transmitters and receivers to the coaxial relay. The half-inch cable is important for minimizing system losses. A similar arrangement can be used at UHF with a 6 dB gain antenna and a 7/8-inch diameter coaxial cable. In a congested site it may be necessary for a single UHF antenna to be shared between two or more channels. An arrangement utilizing a diplexer for this purpose is shown in Exhibit 15-20B. The output ports of the diplexer are connected to the individual transmit receive coaxial relays and the individual transmitters and receivers as before. These coaxial relays should in all cases be located as close to the radio equipments as practical.

If the intermodulation interference problems are such that separate VHF and UHF transmitter and receiver sites are appropriate, then the standard arrangement shown in Exhibit 15-21A can be used for directly connecting a transmitter to an antenna through the appropriate coaxial cable. If it is desirable to combine two or more transmitters into a common antenna or to have two or more receivers share the same antenna, then the standard arrangement shown in 15-21B can be used.

When using diplexers for combining transmitters, it is desirable to have sufficient frequency separation between the two transmit frequencies in order to facilitate the filtering problem. The filtering may, in turn, provide more isolation than that readily available from the free space transmission loss, so that there is

Exhibit 15-20: INTEGRATED TRANSMITTER & RECEIVER SITE CONFIGURATIONS
 (Antennas, Transmission Lines, FR Switches)

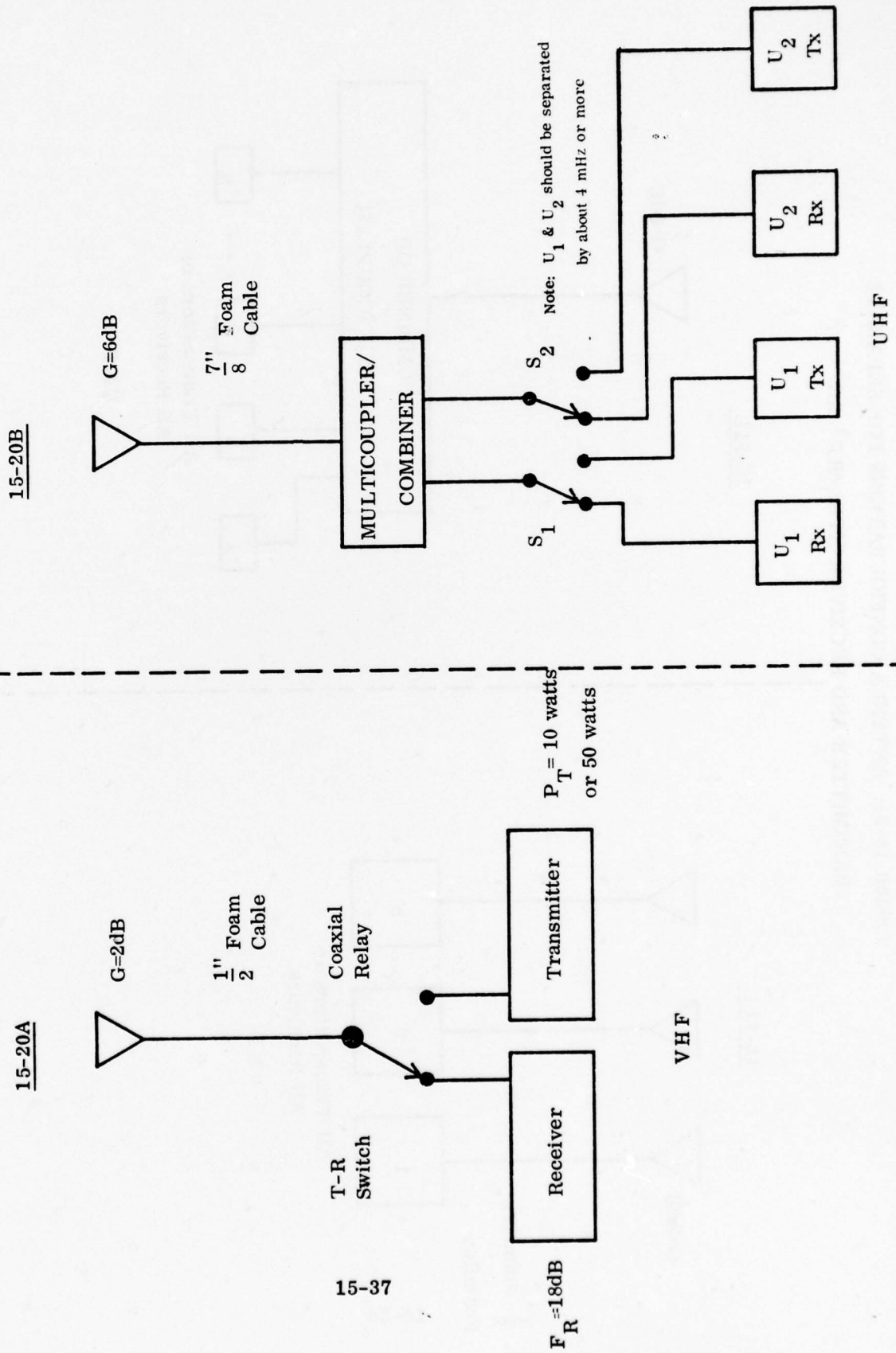
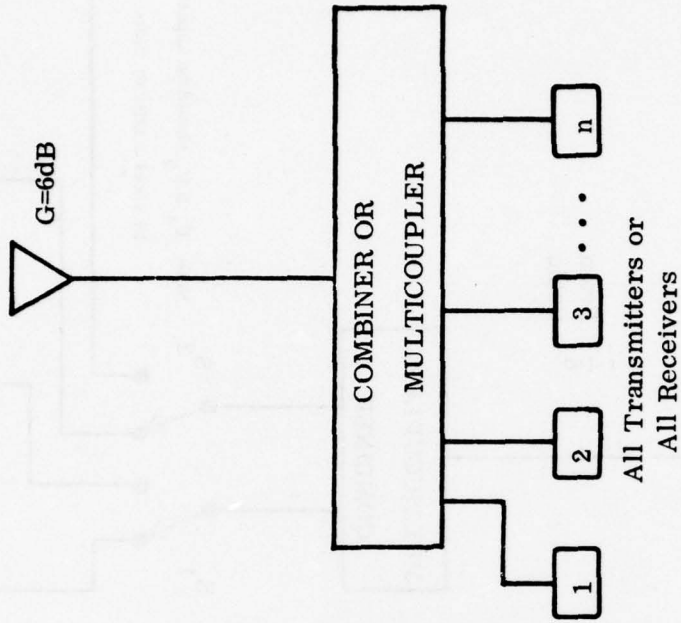

Exhibit 15-21: ANTENNA CONFIGURATIONS FOR SEPARATE
TRANSMITTER AND RECEIVER SITES (RT + RR)

15-21B



UHF

15-21A

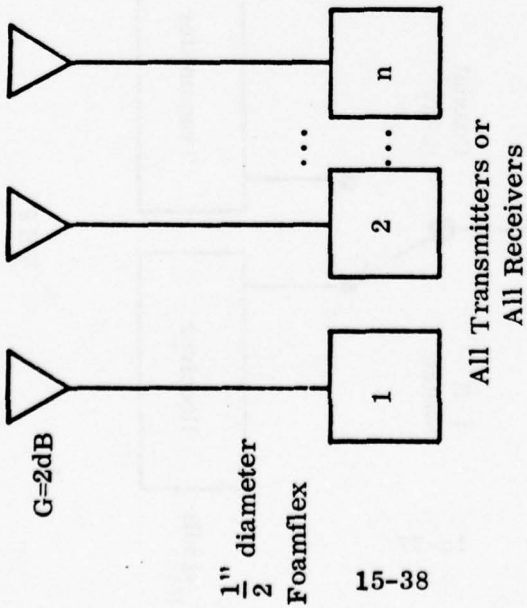

VHF

$\frac{1}{2}$ " diameter
Foamflex

15-38

no interaction between the two transmitters. Diplexer arrangements for sharing transceivers should also have sufficient frequency separation between the two frequencies, to avoid desensitization of receiver 1 when transmitter 2 is energized. This only involves determining the channel separation necessary to achieve some desired amount of isolation from the filters.

15.6 LOADED ANTENNAS

In recent years, the FAA has changed from the old style vertical dipoles to a new style of vertical dipoles which are physically shorter than the older ones but loaded in such a manner as to cover the entire VHF band. The older antennas covered the VHF band in three sub-bands with three slightly different antenna sizes. The basic problem with the loaded antenna is that it is a higher Q device and therefore, when subjected to the proximity of other antennas and/or a tower, it can be more easily detuned than the full-sized lower Q antennas. Although the full-sized vertical dipole antennas, which cover a portion of the VHF band, sometimes provide additional rejection at an undesired frequency located outside their design range, normally this is not significant compared to other filtering in the system. The possible detuning proximity effects, however, are important. It is recommended that these effects be thoroughly investigated before adopting the shortened (loaded) broadband antenna as a standard.

15.7 SUMMARY

In summary, the basic approach to configuring air-ground facilities is to use separate VHF antennas for each frequency, in order to avoid using large and costly diplexers. Existing UHF diplexers, which are reasonable in size, can be considered for current installations. However, since this item is relatively expensive, separate antennas are recommended for each UHF transmitter where space permits. Rather than installing an extra tower for only one or two frequencies, combining pairs of UHF transmitters into a single UHF antenna would most likely be more cost effective. Combining transmitters is also desirable in the case of RCAG installations where real estate is limited.

In the case of a separate receive site, consideration can be given to utilizing active multicouplers, so that one VHF or UHF antenna can be shared between a number of receivers. Generally, these multicouplers have binary power divisions (i.e., two-way, four-way, eight-way, and sixteen-way) and an active device is used to make up for losses due to the power division and I^2R losses within the device. Care must be taken not to use an excessive amount of gain in this amplifier itself. For this application, it is recommended that the multicouplers be limited to a maximum of eight output ports. In addition, it is recommended that the circulator device internal to the receiver be used whenever practical for coupling two or three receivers to a common antenna or to a port of a given multicoupler.

Part Five

NAS RADIO SERVICE

- 16. Air/Ground Radio Service Concept**
- 17. Air/Ground Facilities for NAS Radio Service**

16

AIR/GROUND RADIO SERVICE CONCEPT

16.1 GENERAL OVERVIEW

The concept presented is one which incorporates the results of the various analyses performed in Part Four. The air/ground radio service described here is one in which an integrated service is provided for all users utilizing standardized techniques, procedures, and equipments. The supporting maintenance for air/ground communications is also integrated to include all radio facilities.

Basic to this approach is the assumption that an integrated or universal service that responds to all requirements for air/ground communications is cost-effective. The alternative approach currently employed is to provide a number of communications services that support distinct operational functions (e.g., en route communications, terminal communications and flight service communications). It was evident as a result of examining current operations that such an approach can lead to unnecessary redundancy in facilities, telephone lines, equipments, and personnel. There are many instances of clusters of radio facilities operating in a localized area (within 4 or 5 miles of each other) that serve different functions but exhibit similar radio coverage. Placing an RCAG, an RTR and an FSS in the same general area results in an inefficient utilization of resources that operate independently and cannot be easily shared. It was shown in Chapter 11 that redundancy ratios are minimized by clustering as many equipments and supporting telephone circuits into one facility as is consistent with radio coverage requirements and physical space.

For example, if it is feasible to locate 20 radio equipments in one facility, then three spare radio equipments are required. If the 20 radio equipments are placed in four facilities, then a total of eight spare radio equipments are required. A similar trade-off exists for the supporting leased-line communications. More equipments and lines increase costs, since the additional elements also have to be maintained.

As presented in Chapter 9 (System Design Rationale), the air/ground radio service concept is designed to achieve optimization in:

- (1) Facility placement
- (2) Air/ground network structure
- (3) Standardization
- (4) Automation utilization
- (5) Facility utilization

Exhibit 16-1 shows an overview of the air/ground radio service that incorporates the optimization guidelines listed below.

16.1.1 Facility Placement

Radio facilities are selected on the basis of required radio coverage. Separate radio service functions that can be performed within one radio facility are incorporated (or co-located) within that facility. Facilities are selected (within radio coverage constraints) so that the minimum leased circuit mileage results between the facility and the control site.

16.1.2 Air/Ground Network Structure

The desirability of minimizing leased-circuit costs leads to the use of concentrators as shown in Exhibit 16-1. Locating the Maintenance Subcenters with the concentrators enables detailed maintenance data to be accumulated and processed within the responsible Airways Facilities Maintenance Sector. Performance monitor data from the remote radio facilities (including NAVAIDS) are intercepted at the Maintenance Subcenter, so that transmission is not required to the ARTCC.

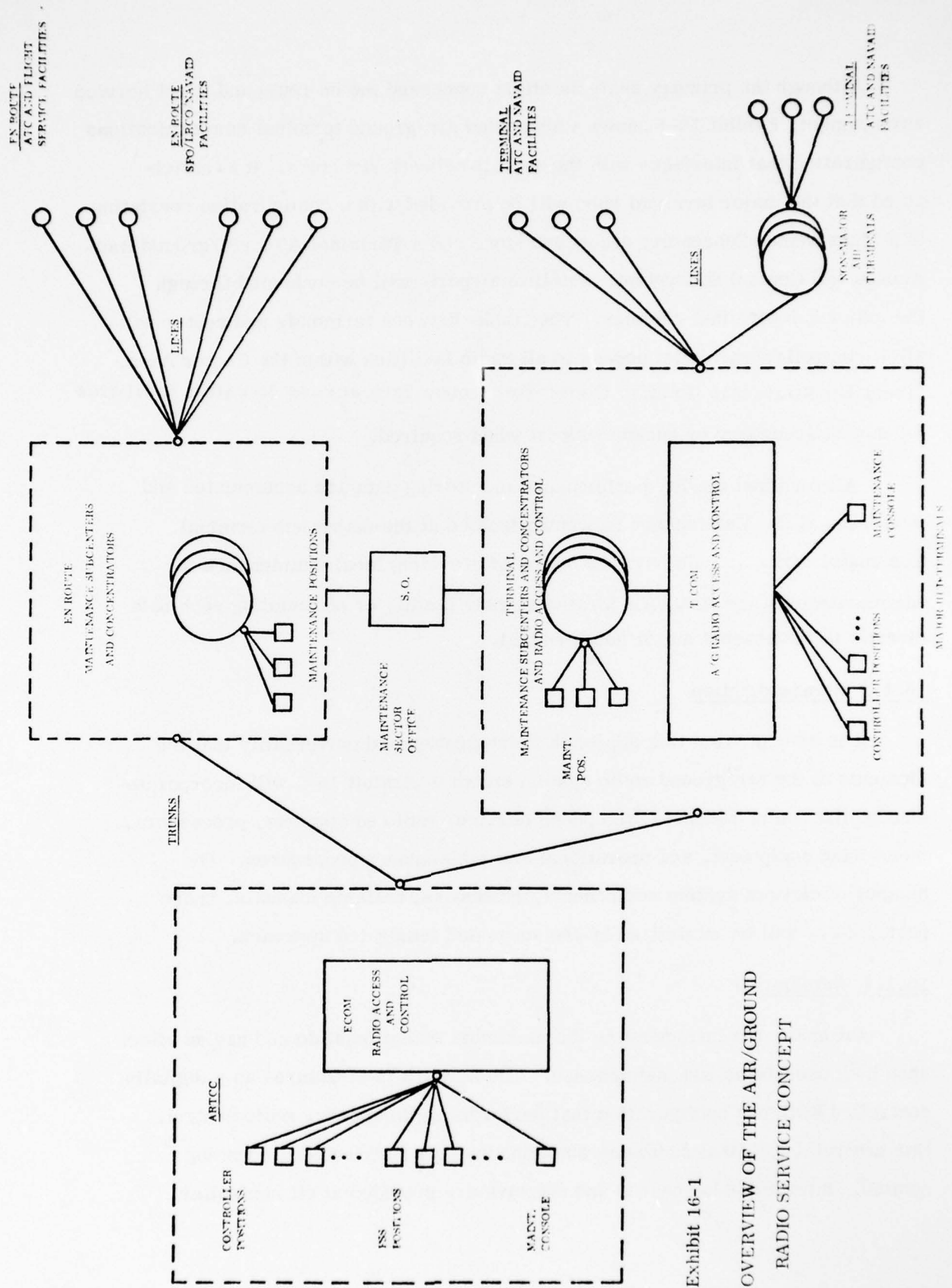

Exhibit 16-1

OVERVIEW OF THE AIR/GROUND RADIO SERVICE CONCEPT

Although the primary analysis effort concerned the en route and flight service environment, Exhibit 16-1 shows a suggested air/ground terminal communications configuration that interfaces with the overall network structure. It is anticipated that the major terminal hubs will be provided with a configuration consisting of a Maintenance Subcenter, a concentrator, and a Terminal ATC air/ground Radio Access and Control Subsystem. Satellite airports will be connected through the major hub terminal complex. The trunks between terminals and center will allow controller/specialist access to all radio facilities within the Center Area. Thus En Route Air Traffic Controllers may gain access to radio facilities for use as secondary or backup support when required.

All terminal facility performance monitoring data are accumulated and processed at the Maintenance Subcenter located at the major hub terminal. Non-major air terminals have the option of providing local maintenance for communications and NAVAIDS located at their facility or of remoting such data directly to the nearest major hub terminal.

16.1.3 Standardization

It is evident from this approach to integration and universality that the elements of the air/ground radio system shown in Exhibit 16-1 will incorporate standardization of facilities, telephone service, radio equipments, processors, monitoring equipment, and operational and maintenance procedures. The number of distinct system components, handbooks, training manuals, spare parts, etc., will be minimized by the suggested integrated approach.

16.1.4 Automation

Automation is introduced to the maximum extent feasible and has an effect upon both operations and maintenance. The network is structured as a digitally controlled switched configuration that performs radio access, radio control, line control and logical switching functions under a distributed processing system. Interactive keyboards and displays are provided at all controller,

flight service and maintenance positions. The digital data link option, if implemented, will provide an automated interface with NAS UTG functions, and also provide performance checking of radio channels. Facility remote performance monitoring, maintenance procedures, and record keeping have been automated utilizing micro/mini processors.

16.1.5 Facility Utilization

The radio facilities are utilized to the maximum extent consistent with required radio coverage. The resulting clusters of radio equipments and supporting telephone lines allow a substantial reduction in redundant elements without degradation of the required service availability. The use of solid-state radio equipments provides sufficient space at most current radio facilities to allow a significant increase in the number of equipments assigned. Additionally, the incorporation of less than one-to-one redundancy of radio equipments results in the availability of more space relative to current facility configurations.

The various major elements shown in Exhibit 16-1 are described below.

16.2 CONTROL SITE

Exhibit 16-2 shows the Control Site configuration. A space division, solid state, common control, cross point switch is employed as the major switching element connecting the operating positions to outgoing/incoming trunk circuits. Controller positions are connected directly to assigned radio facilities and radio equipments fixed tuned to sector frequencies. The various controller options previously described are keyed in from the appropriate positions. Flight service positions are also connected to the switch, which functions to select circuits to called or calling facilities on demand access. The maintenance position monitors overall performance of the air/ground radio system and also directly monitors and controls the local Radio Access and Control Subsystem.

Exhibit 16-2

CONTROL SITE CONFIGURATION
RADIO ACCESS AND CONTROL

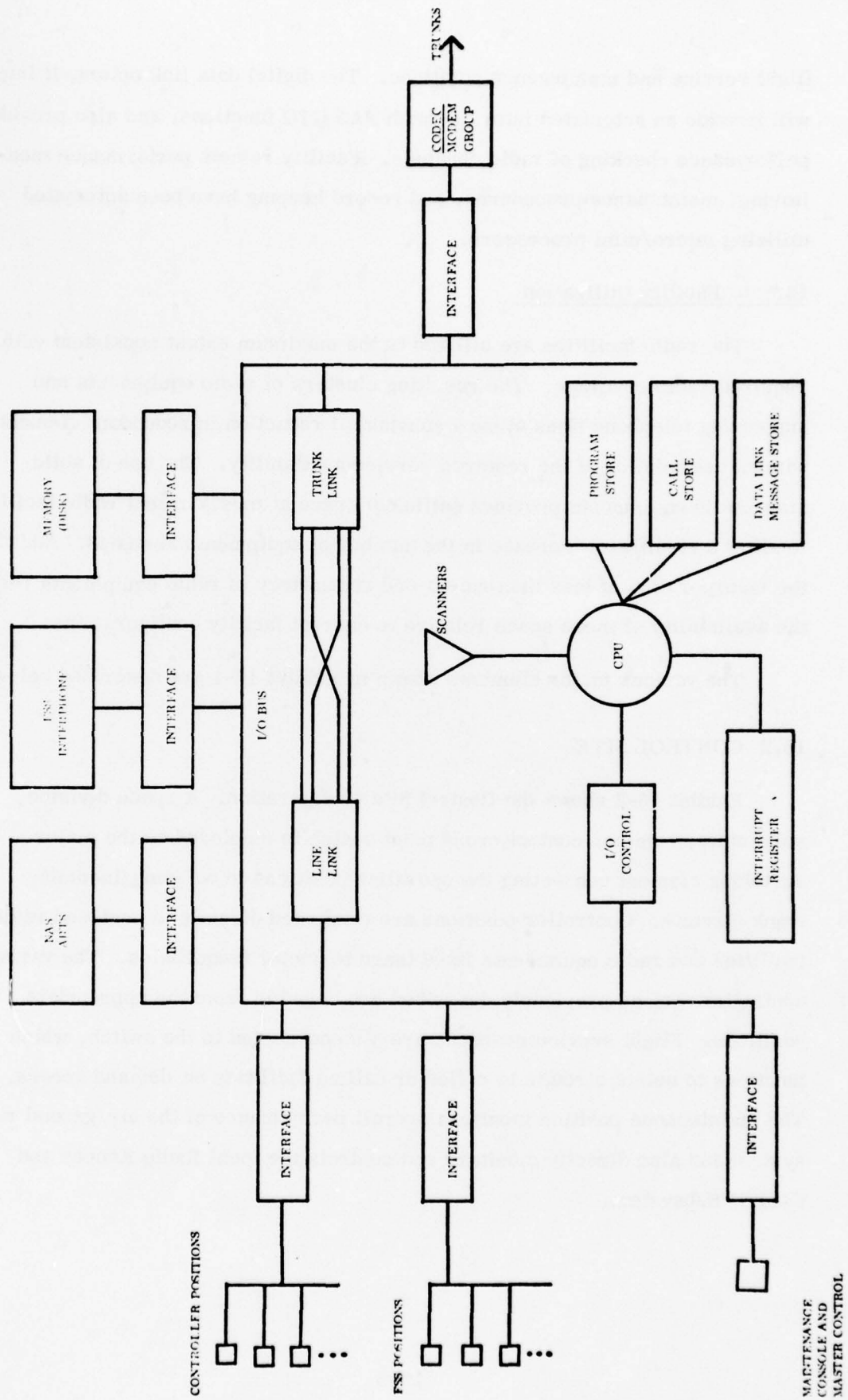

Interfaces are established with the Interphone System through its switch (EVS or equivalent) and also with NAS Automation functions that can flow directly through the radio switch to data-link-equipped aircraft. As described earlier, there are a significant number of air/ground messages (alphanumeric) that adapt more effectively to data link transmission and save considerable controller communication time. The class of housekeeping messages (e.g., assigned frequency, beacon code, altimeter reading) may be stored in the Data Link Message Store shown in Exhibit 16-2 and transmitted whenever an aircraft is "handed off" between sectors. Additionally, Conflict Alert messages may be transmitted in real time with concurrent controller alert. In the terminal area, the clearance delivery messages may be transmitted digitally directly to requesting aircraft. If metering and spacing is implemented, this class of messages may also be transmitted digitally via the air/ground channel.

16.3 MAINTENANCE SUBCENTER

The Maintenance Subcenter configuration is shown in Exhibit 16-3. The Subcenter functions to effect a concentration of lines to trunks and also as a maintenance center to collect and process all air/ground and NAVAID facility performance data incoming from the facilities within its sector.

The maintenance positions are interactive keyboard displays that allow selective testing of radio/NAVAID facilities as well as monitoring of performance parameters incoming from the various facilities. The number of positions is a function of the number of facilities reporting to the Subcenter. The maintenance procedure suggested as most effective is to continue to carry out site certification and preventive maintenance by scheduled visits. The Maintenance Subcenter operation will focus on unscheduled failures and real time service restoral and rapid repair. As previously described, for voice radio communications the on-line performance assessment is handled subjectively by the Air Traffic Controller and the Flight Service Specialist. All off-line equipments and spare telephone lines are automatically checked by the previously outlined performance monitoring and

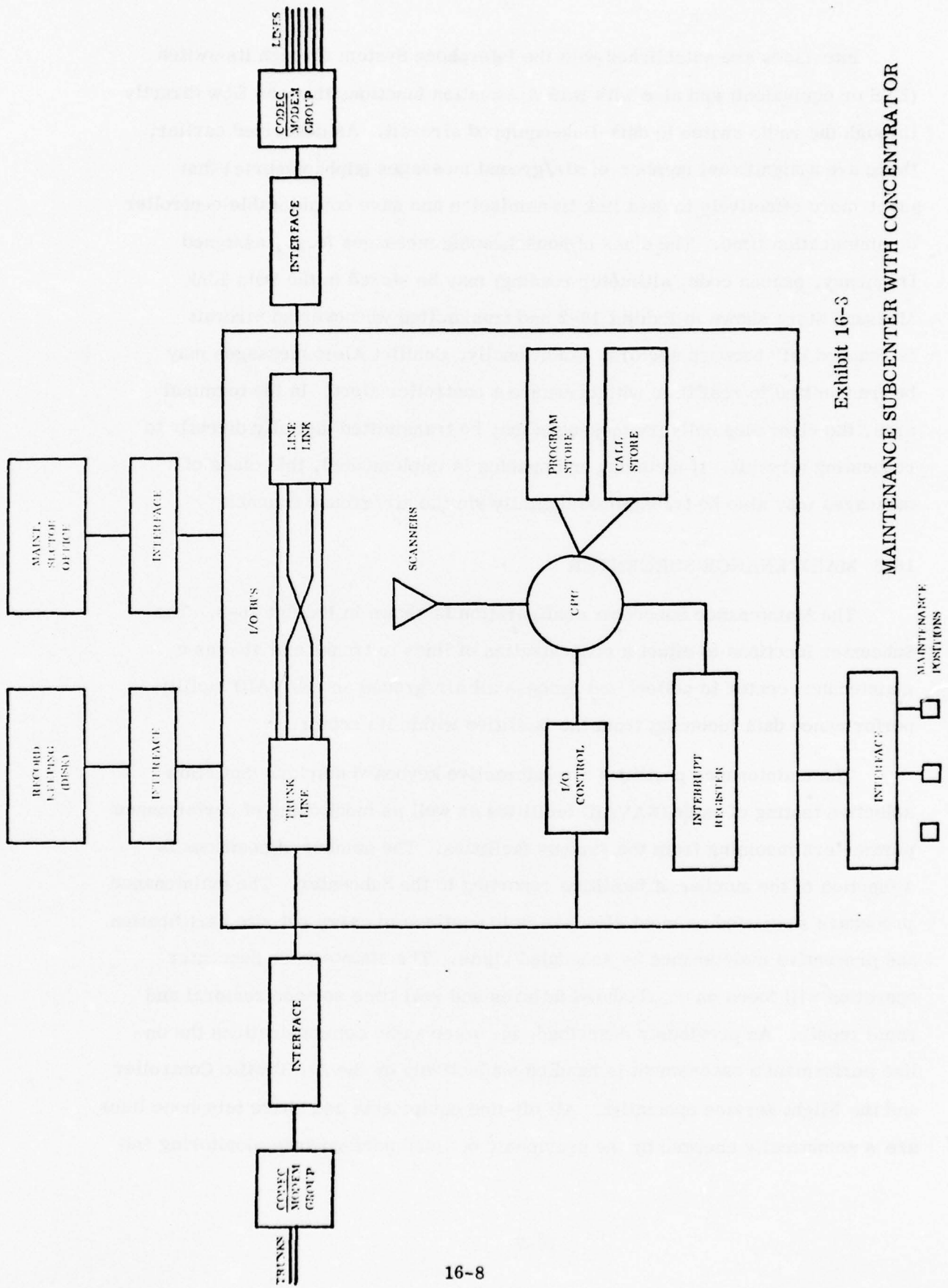

Exhibit 16-3

MAINTENANCE SUBCENTER WITH CONCENTRATOR

test procedures. For data communications, the telephone lines and radio channels are automatically checked with each transmission. Detection of excessive word errors will cause a switchover of line, radio equipment or radio facility, depending upon the failure isolation. As is seen in Exhibit 16-3, the CODEC/MODEM group on incoming and outgoing circuits results in signal regeneration at the Maintenance Subcenter. Thus, there is no accumulation of noise on the signal path. Regeneration also takes place at the radio facility. This is a by-product of the decoding operation required at the Maintenance Subcenter in order to retrieve the performance monitor messages and the incoming calls for flight services.

The Subcenter also functions as a record-keeping repository of performance statistics for all radio and NAVAID facilities. The history of performance for any element of any facility may be retrieved from the store shown in Exhibit 16-3.

The Subcenter provides an interface to drive a remote terminal located at the Sector Office. Summary data are transmitted to the Sector Office, which may also query for more detail.

16.4 RADIO FACILITIES

Each radio facility and NAVAID is equipped with a microprocessor, peripheral sensors and threshold logic, which automatically report unscheduled failures of facility subsystems and initiate switchover to a redundant element. The facilities may also be sequenced through tests of off-line radio equipments at the option of the Maintenance Subcenter.

A specific radio facility will be allocated fixed tuned solid state radio equipments (transmitter and receiver) for each assigned radio frequency. Spare radios, of the tunable solid state transceiver type, will be assigned in accordance with the redundancy ratios calculated previously.

For en route facilities (RCAGs), the antennas will be configured with one antenna for each transmitter-receiver pair, employing a TR switch. If more than 16 frequencies are assigned to a facility, then the excess frequencies at UHF will be combined through grouping equipments on single antennas as described in Chapter 15.

For terminal facilities, the radio site configuration design will depend upon number of assigned radio frequencies and the available distance between site locations on the airport. Assuming the requirement for more than one facility, either two or more RTRs will be employed, or else a mix of RTs and RRs, depending upon the separation criteria discussed in Chapter 15.

Spare telephone lines will be assigned to each facility on the basis of the redundancy ratios calculated in Chapter 15.

Radio transmitter power levels, receiver noise figure, and detailed site geometry (i.e., antenna tower heights, antenna extensions from tower platforms, etc.) will be determined as a result of further analysis, test and evaluation (Phase II of the present contract).

16.5 DESIGN METHODOLOGY

It is evident from the study and analysis carried out that standardization is appropriate within limits. Each Center Area exhibits a set of different characteristics related to air activity, sector configuration, location of radio facilities, and terrain. The concept described is generalized on the basis of examination of one area (ZOA), and the variations in area characteristics must be considered in a realistic and practical system design. It appears that an effective approach is to examine air/ground radio communications from the aspect of specific center operations and related sector maintenance. The methodology employed in this study is applicable to Center Area configurations, and includes the following sequence:

- (1) **Airspace Considerations**-- an identification of sector volumes for en route, terminal and flight service operations.
- (2) **Facility Identification**--a listing of current radio and NAVAID facilities, giving locations, functions, equipments, and general configuration.
- (3) **Radio Coverage Analysis**--using ECAC contours to determine the correlation between facility coverage and sector assignments.
- (4) **Reliability Analysis**--an assessment of expected performance relative to MTBF and MTTR for all elements of the air/ground path through each facility.
- (5) **Network Analysis and Design**-- based on the location of facilities and potential locations for Maintenance Subcenters and Concentrators.
- (6) **Quantitative Assignment of Numbers of Lines, Trunks, and Radio Equipments**--based on the reliability analysis as well as number of required radio frequencies.
- (7) **Sizing of Facility, Maintenance Subcenter and Control Site Processors**--based upon the results of (6) above and the number of required Control Site positions.
- (8) **Detailed Radio Facility Design**--based upon site location, site geometry, radio frequency environment, number of assigned frequencies, and assigned functions (i.e., en route ATC, terminal ATC, flight services).
- (9) **Interface Analysis and Design**--based upon the required interface arrangements with related NAS automation (NAS/ARTS).
- (10) **Maintenance Procedures**--based upon the location of facilities, Maintenance Subcenters, Sector Offices, logistics and routine maintenance requirements.

The application of the above methodology will result in a standardized air/ground radio service accounting for variations in conditions existing within the 20 center areas.

16.6 SUMMARY

The concept described achieves the objectives of a cost-effective air/ground radio service that will respond to all current requirements and all anticipated future requirements, and also introduces flexibility and substantial growth potential.

The concept is described in sufficient detail to allow the initiation of an engineering specification which will define detailed expected performance criteria for each of the major subsystems.

17

AIR/GROUND FACILITIES FOR NAS RADIO SERVICE

17.1 GENERAL

As discussed in Chapter 11, the Air/Ground Radio Facility, together with the control site, is the most reliable of the five subsystems that comprise an air/ground path. The required availability of service (i. e. , 0.99998) can be achieved with the recommended number of spare radio equipments and careful design of the switching and control logic required for performance monitoring and radio control.

The major thrust of radio facility reconfiguration is in the two areas of automated maintenance procedures and radio frequency environment.

Automated maintenance procedures for the detection and isolation of unscheduled failures plus real time service restoral has been discussed in Chapter 13. A modest approach was selected that allows a relatively simple design and involves neither modification to any equipments nor the use of expensive and complex test equipment. It is assumed that scheduled maintenance visits on the order of one visit each three or six months will allow the performance of site certification and routine maintenance. It may be feasible for the visiting site technician to carry the required test instrumentation (signal generator, frequency counter, etc.) to each site visited so that permanent placement of these items will not be necessary.

The second area of concern involves the reliability of the radio propagation path. Site geometry, with respect to arrangement of antennas, is a most important consideration. The objective is to configure each site so that the required number of radio frequencies may be operated without the occurrence of excessive RFI. This consideration becomes particularly important with respect to those sites selected for en route ATC

and Flight Services support, because the number of assigned frequencies will increase in most cases.

As discussed in Chapter 11, the availability signal margin is not sufficiently adequate to assure required reliability. Additionally, Chapter 11 discussed the occurrence of RFI due primarily to intermodulation interference as a potential source of performance degradation. Since little or no data exist as to radio channel performance over air/ground propagation paths, and since IM product generation may be generated by a number of yet-to-be-identified sources, it is speculative to present recommended frequency management, site geometry and power budget parameters. However, the procedures suggested in Chapter 15 are generally recommended as means for minimizing the number of antennas and thus reducing the probability of IM, regardless of the source.

The treatment of RFI due to IM product generation will become a trade-off based upon the evaluation of its frequency of occurrence and intensity. Frequency management is one technique limited by the available set of radio frequencies; if the problem is sufficiently severe, then alternate techniques, such as shifting to double sideband suppressed carrier (DSB-SC), may be considered as a means of eliminating carrier interference. This solution involves radio redesign, which has been avoided because of the current FAA procurement program of solid state radio equipments which are just beginning an operational life cycle ranging up to 15 years. (As previously noted, there are vintage radio equipments operating that were installed in 1950--a life cycle of 26 years.)

As an example of radio facility configuration, the Mt. Tamalpais RCAG (ZOA) was selected, since a substantial number of radio frequencies were assigned to that facility as an application of En Route ATC and Flight Service co-location.

17.2 RADIO SITE CONFIGURATION

Exhibit 17-1 shows the current site layout for Mt. Tamalpais RCAG (ZOA). It is noted that the building is suitable for 20 racks of equipment. The site employs three delta towers for antenna support structures. The distance between towers is approximately 80 feet. The engine generator is housed in a separate shelter as shown.

Exhibit 17-2 shows the current antenna layout with respect to the RCAG structure and tower mounts. The delta towers are approximately 17 feet per side, which allows a space of eight feet between antennas (assuming three antennas on a side). Exhibit 17-3 shows the current frequency assignments for the various antennas. It is noted that two towers have been reserved for separate transmitting and receiving structures.

Exhibit 17-4 shows the current Mt. Tamalpais RCAG floor plan with its 20 equipment rack configuration. For a reference, the principal cost data elements for Mt. Tamalpais appear in Exhibit 10-29. The reconfiguration of the Mt. Tamalpais RCAG in order to implement the en route ATC and Flight Service functions, as indicated in Chapter 10, involves the following:

- Physical accomodation of required radio equipments
- Physical accomodation of required antennas
- Minimization of RFI relative to the modified antenna configuration
- Modification of equipment and Telco line redundancy
- Introduction of switching, control and monitoring subsystem for automated maintenance and radio control

17.2.1 Physical Accomodation of Required Radio Equipments

Exhibit 17.6 shows the tentative assignment of radio frequencies as developed for Mt. Tamalpais in Chapter 10. As noted, there are 14 VHF frequencies and 11 UHF frequencies listed to support HAT ATC, LAT ATC, and Flight Services.

Exhibit 17-7 illustrates a possible arrangement of radio equipments and peripheral elements required for facility operation. The equipment shown occupies 16 racks, which leaves 4 racks for growth potential or other utilization.

The configuration shown assumes an all solid state radio equipment installation comprising fixed tuned primary radio equipments and tunable transceiver spares. The items identified by asterisks are new, and engineering specifications have not been developed for them.

It is evident that, for this example, the facility can accommodate the equipment assignment. Mt. Tamalpais was assigned the largest number of radio frequencies within ZOA (en route functions), so that it is reasonable to assume that the remaining facilities can also accommodate the suggested assignments of frequencies.

17.2.2 Physical Accomodation of Required Antennas

Figure 17-8 illustrates a possible modified arrangement of antennas and frequency assignments consistent with the frequencies listed in Exhibit 17-6. In keeping with the guidelines developed in Chapter 15, the transmitters and receivers share an antenna through a coaxial switch. Additionally, UHF assignments have been paired on four of the antennas requiring the use of multi-coupler/combiners.

The swastika antennas have been replaced with VHF coaxial antennas with 2.2 dB gain. UHF antennas with 6 dB are employed.

Antenna multiplexers are employed to share antennas among the UHF radio frequencies. Exhibit 17-9 illustrates the configurations employed. Exhibit 17-10 shows typical selectivity characteristics for a Collins Radio unit. The specification is shown in Exhibit 17-11. It is noted that the multiplexer provides a minimum of 60 dB isolation for channel spacing as low as 3.75 MHz.

17.2.3 Minimization of RFI

A computer program was written to assess the number of third order IM products of the Mt. Tamalpais facility, assuming the radio frequency assignment as per Exhibit 17-6.

The results are shown in Exhibit 17-12, which lists 44 third order IM products. Sixteen of the products are eliminated by removing two frequencies, the VHF emergency frequency (121.5) and 133.7. Deleting 122.0 eliminates

8 additional products, and deleting 122.5 eliminates the remaining products. These results are first order, in that many of the product levels may be below receiver threshold. Additionally, the probability of the generating frequencies being transmitted simultaneously is unknown. Finally, the utilization of emergency frequencies has a very low duty cycle, so that the contribution to interference from this source may be minimized.

The IM product program listing is shown in Exhibit 17-13.

17.2.4 Modification of Redundancy of Radio Equipments and Telco Lines

There are 13 radio channels (each channel comprising 1 VHF and 1 UHF frequency). Therefore, assuming one telephone line for paired operation, the total number of primary remote Telco lines required is 13. For 13 primary lines it is necessary to add four spare Telco lines in accordance with the reliability analysis of Chapter 11. The telephone line service availability will approach 100% with the utilization of 17 lines (13 primary plus 4 spare).

There are 25 primary radio equipments assigned to Mt. Tamalpais (13 VHF plus 12 UHF). Therefore three spare VHF tunable transceivers and three spare UHF tunable transceivers are required to achieve an availability of 0.99998 for the radio equipments (see Exhibit 11-8).

For this particular example, current practice would utilize $25 + 25 = 50$ radio equipments so that there is an effective reduction in equipments of $50 - 31 = 19$.

An additional advantage of this arrangement of collocation is that the FSS-assigned radio equipments receive the same degree of redundant protection as the ATC equipments.

17.2.5 Introduction of Automated Maintenance and Radio Control

As indicated in Exhibit 17-7, which illustrates the complement of equipments, several subsystem elements are added in order to achieve real time radio control as well as automated facility monitoring. The discussion in Chapter 12 described the function and operation of the units required. The microprocessor and MODEM

elements are state-of-the-art hardware and may be purchased subsequent to specification. The coding (CODEC), maintenance switching and control logic, and radio switching and control logic also involve state-of-the-art hardware components, but must be applied (i.e., configured) for the operations required. It is planned to develop the appropriate engineering specifications for those subsystem elements as part of Phase II of the current contractual effort.

It is evident from the facility reconfiguration considerations described that the current structures, antenna towers, antennas, solid-state radio equipments, and peripheral subsystems (i.e., power) may be retained. The principal modifications lie in the areas of antenna reconfiguration and in the addition of automated switching and control.

More substantial efforts are required in the reconfiguration and design of the control site and the Maintenance Subcenter. Additionally, further modification to site geometry and radio signal levels may be required in order to increase the radio propagation path reliability.

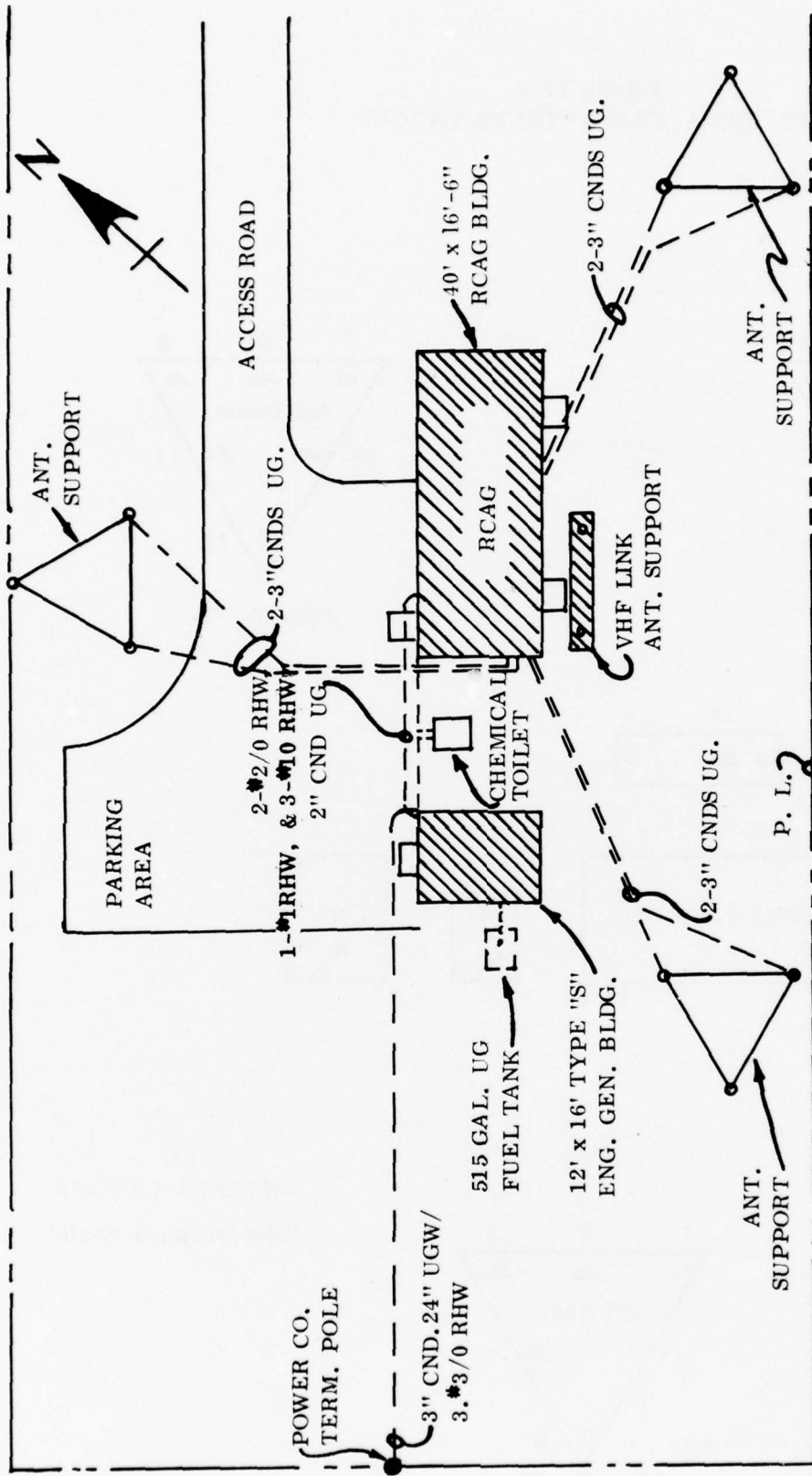

17-7

Exhibit 17-1

MT. TAMALPAIS SITE LAYOUT

KEY PLAN

Scale in Feet



Exhibit 17-2
 MT. TAMALPAIS ANTENNA LAYOUT

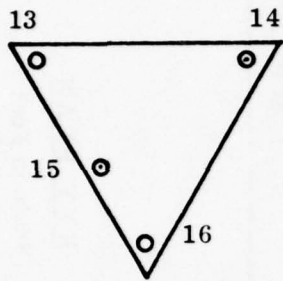

DELTA #3

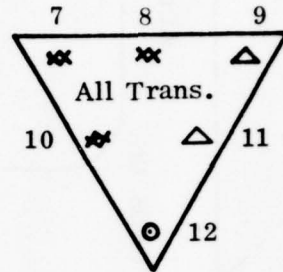

DELTA #2

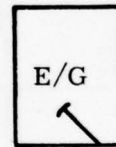
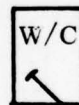
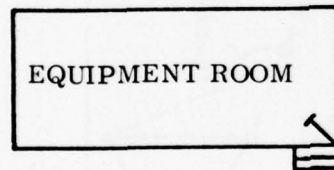
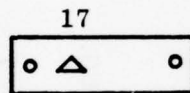

MPA
 ANTENNA LAYOUT

"Not Drawn to Scale"

MPA
 ANTENNA LAYOUT LEGEND

- COAXIAL, VHF RCV, TYPE FA-5441 OR CA-1719
- △ DISCONE, UHF, TYPE AT-197
- STACKED ARRAY, UHF, TYPE AS-768
- ✕ SWASTIKA, VHF XMT, TYPE CA-1781

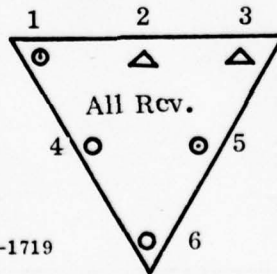

DELTA #1

Exhibit 17-3

MT. TAMALPAIS CURRENT FREQUENCY ASSIGNMENT

ANT.	FREQ	XMIT	RCV
1	281.4		CH 43
2	323.0		CH 44
3	353.5		CH 45
4	132.2		CH 43
5	UHF		SPARE
6	126.5		CH 44
7	126.5	CH 44	
8	132.2	CH 43	
9	UHF	SPARE	
10	127.8	CH 45	
11	323.0	CH 44	
12	353.5	CH 45	
13	VHF		SPARE
14	281.4	CH 43	
15	UHF	SPARE	
16	127.8		CH 45
17	UHF		SPARE

Exhibit 17-4
MT. TAMALPAIS RCAG BUILDING

40'

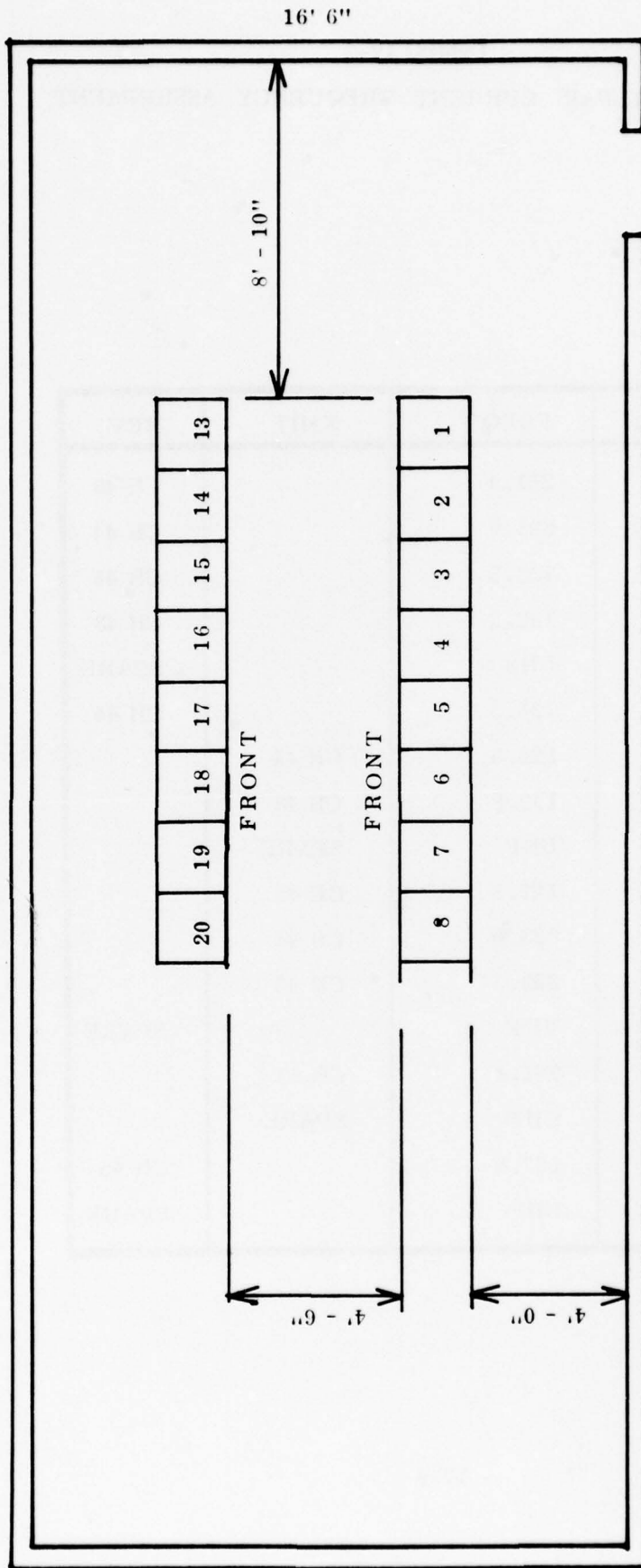

17-10

PLAN
SCALE 1/4" = 1' - 0"

Exhibit 17-5
 MT. TAMALPAIS
 REMOTE COMMUNICATIONS AIR/GROUND SITE
 COST DATA

Latitude	37° - 55' - 37"N	
Longitude	122° - 37' - 40"W	
Elevation	2524' MSL	
Access Rd. mtce. - annually (L & Mtl)		455.00
Eng/Gen Fuel (1 yr)		200.00
Power		2074.00
Lines (4)		9229.00
Real Estate = \$2400/ 1 1/3A - 1982		2400.00
Manpower (GS 11/5 x 1.18/yrs (PLT/ELEC)		<u>21739.00</u>
TOTAL		36097.00

DESCRIPTION	QTY.	COST	
		Unit	Total
CA - 1620/3 Rly Pnl	4	521.00	2084.00
CA - 1621 Tone Cabinet	4	1478.00	5912.00
RCVR Mute Pnl	4	125.00	500.00
CA - 1782 R.O. Amp	2	200.00	400.00
CA - 1622 Pwr Supply	4	114.00	456.00
FA - 8972 Coax Rly Pnl	5	25.00	125.00
R - 361 UHF RCVR	8	576.00	4608.00
T - 282 UHF XMTR	8	935.00	7480.00
MD - 141 Mod Pwr Sup	8	462.00	3696.00
CA - 1589 R.O. Amp	2	200.00	400.00

Exhibit 17-5 (cont'd.)
 MT. TAMALPAIS
 REMOTE COMMUNICATIONS AIR/GROUND SITE
 COST DATA

DESCRIPTION	QTY.	COST	
		Unit	Total
TV - 6 VHF XMTR	6	1250.00	7500.00
RV - 6 VHF RCVR	6	216.00	1296.00
AM - 447 Dual Monitor Pnl	1	200.00	200.00
Monitor Spkr Pnl	1	150.00	150.00
FA - 5444 VHF Coax Rcv Ant	4	56.20	224.80
AT - 197 UHF Discone (FA 8955)	5	56.00	280.00
AS - 768 UHF Stacked Array	5	700.00	3500.00
CA - 1781 VHF XMT Swastika	3	70.00	321.00
UHF Ant Support	3	1125.00	3375.00
25 KVAO Eng/Gen	1	12000.00	12000.00
MT 686 UHF Rack	8	200.00	1600.00
FA-5242A VHF Rack	8	282.00	2256.00
FA-8972 Coax Rly Pnl	6	62.00	372.00
Work Bench	2	60.00	120.00
Cabinets	3	85.00	225.00
Chem. Toilet	1	150.00	150.00
Eng/Gen Batts	4	300.00	1200.00
30 kw Load Bk	1	900.00	900.00
SW Brkr Pnl	1	1500.00	1500.00
Distr Pnl	2	800.00	1600.00
Test Equipment		13000.00	13000.00
Air Cond	8 ton	2400.00	2400.00
Heating	1 ton	100.00	100.00
TOTAL			79930.00

Exhibit 17-6
 MODIFIED MT. TAMALPAIS FREQUENCY ASSIGNMENTS

<u>Facility</u>	<u>Function</u>	<u>Sector</u>	<u>VHF/UHF</u>	
Mt. Tamalpais	HAT/ATC	31	134.35/290.5	
		32	132.95/269.1	
		34	134.45/269.3	
		34	132.45/307.3	
		42	128.15/281.5	
		43	132.8/319.1	
		44	133.5/290.5	
		45	133.7/285.4	
		50	126.8/335.6	
		LAT/ATC	50	126.8/335.6
		EFAS	A	122.0
		EMERGENCY	A	121.5/243.0
		FSS	A	122.5/255.4
		FSS	A	122.3

Exhibit 17-7: MT. TAMALPAIS RACK LAYOUT (16 RACKS)

QUANTITY (D) RACK	QUANTITY (D) RACK	QUANTITY (D) RACK	QUANTITY (D) RACK
MICROPROCESSOR* (DUAL)	ANT. COAX RELAY & RF BODY PANEL	VHF/DF RECEIVER (OPTIONAL)	
SWITCHING AND* THRESHOLD LOGIC	VHF EXCITER T-1108/GRT-21	VHF TRANSCEIVER #3311 (SPARE)	VHF/DF LOCAL INDICATOR (OPTIONAL)
DISTRIBUTION* PANEL	VHF POWER AMP. AM-6151/GRT-21	VHF TRANSCEIVER #3311 (SPARE)	CODEC/MODEM* (SPARE LINE)
LOCAL CONTROL* & DISPLAY UNIT	VHF RECEIVER AN/GRR-23	UHF TRANSCEIVER #3312 (SPARE)	CODEC/MODEM* (SPARE LINE)
	ANT COAX RELAY & RF BODY PANEL	UHF TRANSCEIVER #3312 (SPARE)	CODEC/MODEM* (SPARE LINE)
	UHF EXCITER T-1109/GRT-22	REMOTE CONTROL UNITS C-7824	
	UHF POWER AMP. AM-6155/GRT-22	REMOTE CONTROL UNITS C-7824	
	UHF RECEIVER AN/GRR-21	RADIO SWITCHING* & CONTROL UNIT	
	CODEC/MODEM* (LINE)		
	CODEC/MODEM* (RF-Channel)		

* unspecified

Exhibit 17-8
 MT. TAMALPAIS FREQUENCY - ANTENNA CONFIGURATION

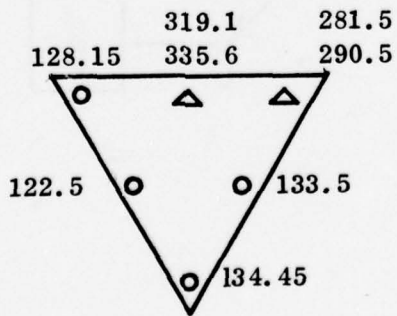
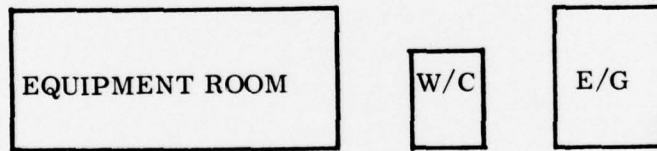
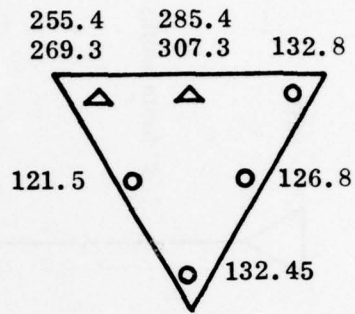
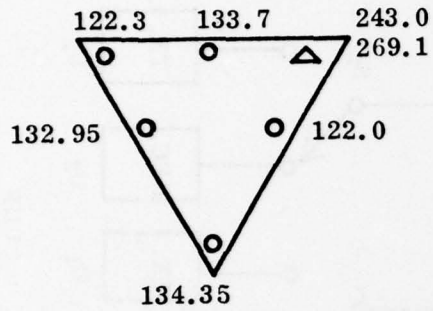

Exhibit 17-9

MT. TAMALPAIS ANTENNA SWITCHING CONFIGURATION

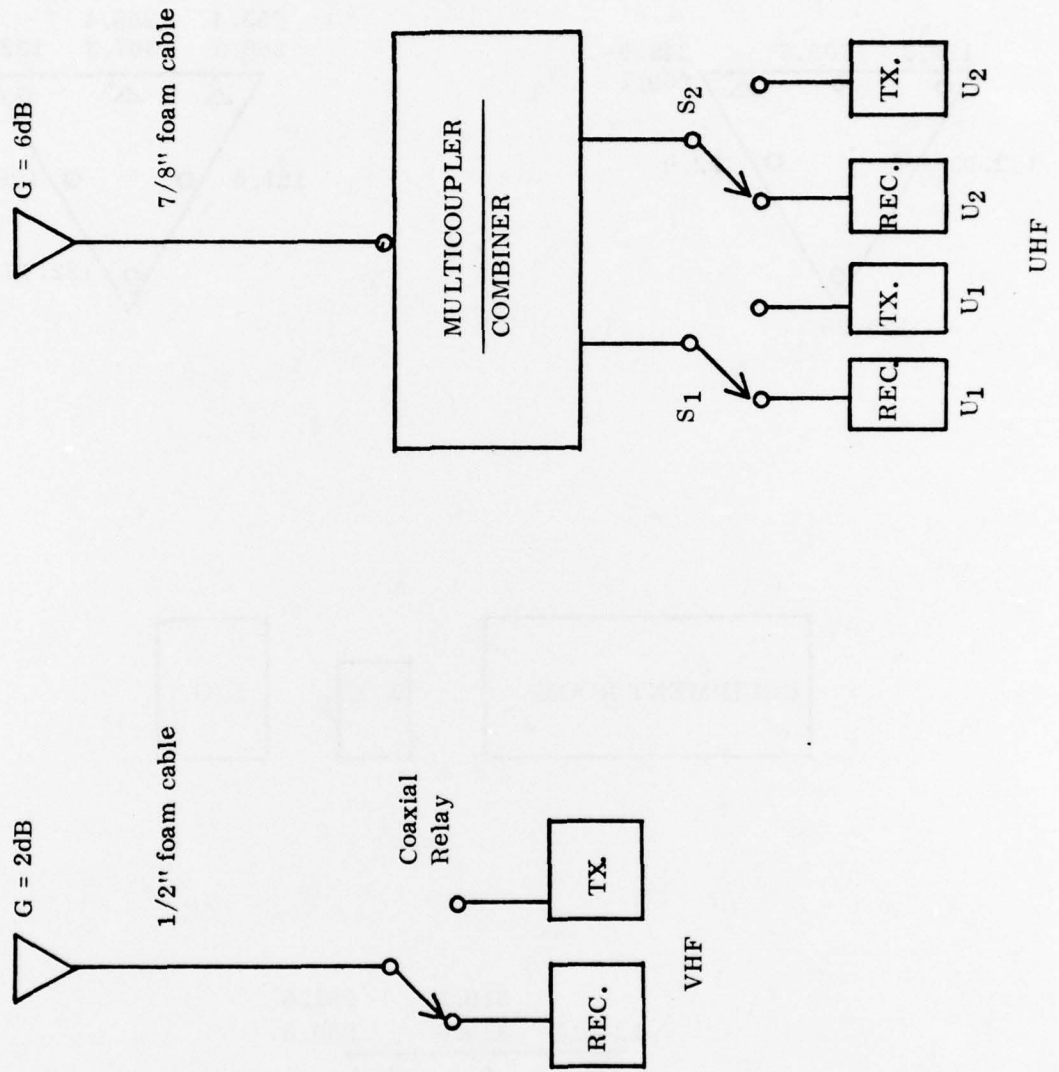

Exhibit 17-10
TYPICAL SELECTIVITY CHARACTERISTICS

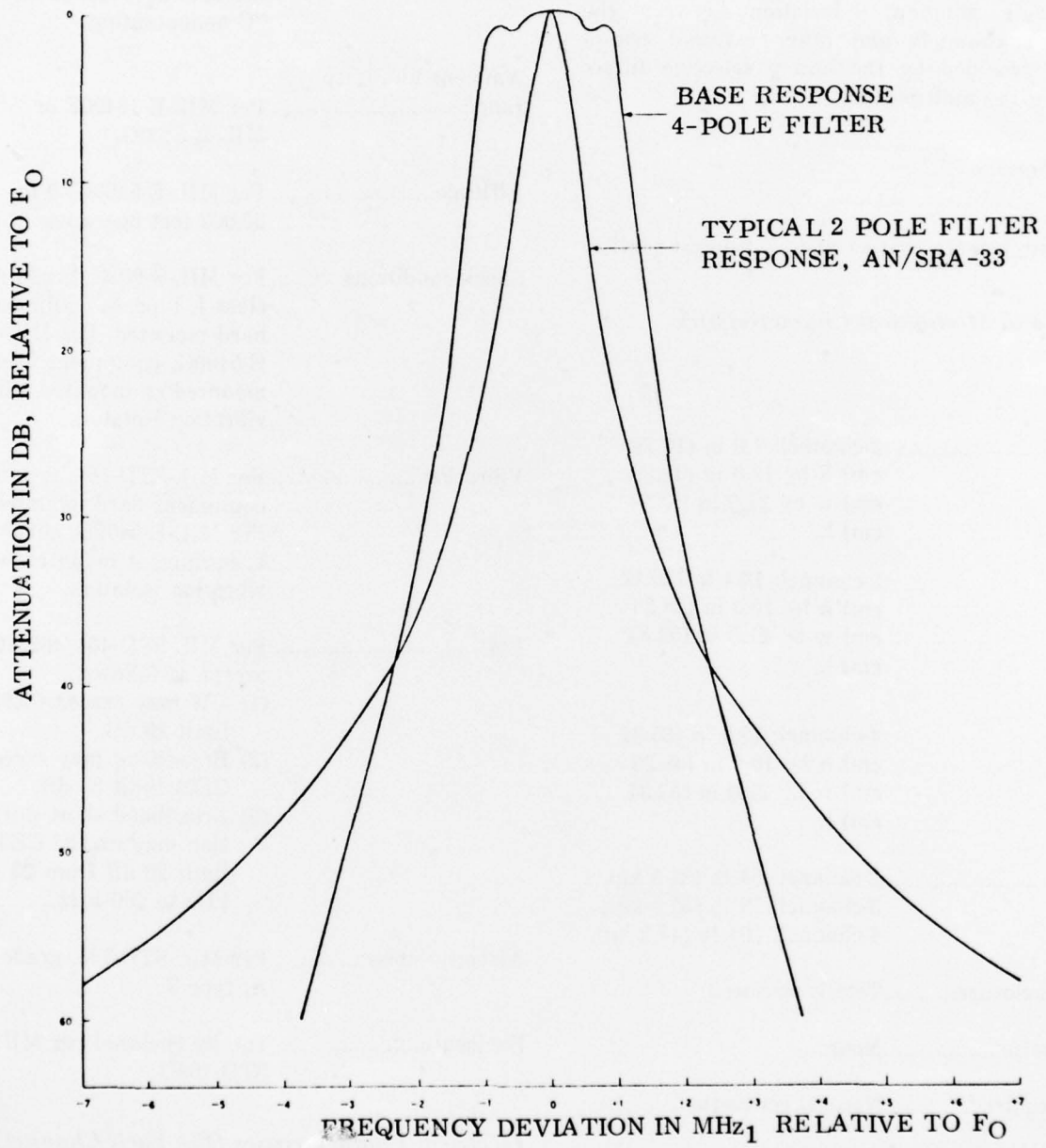

Exhibit 17-11

UHF MULTIPLEXER EQUIPMENT SPECIFICATION, (2-, 3-, or 4-channel)

Type and Function of Equipment

The 2-, 3-, and 4-channel uhf multiplexer allows simultaneous operation of transmitters, receivers, transceivers, or combinations thereof, on a single antenna. Isolation between the multiplexer channels and other external equipments is provided by the highly selective filters comprising the multiplexer.

Type of Service

Unattended, remote control and continuous service.

Physical and Mechanical Characteristics

Size.....2-channel: 7.0 in (17.78 cm) h by 19.0 in (48.26 cm) w by 21.0 in (53.34 cm) l.
3-channel: 10.4 in (26.42 cm) h by 19.0 in (48.26 cm) w by 21.0 in (53.34 cm) l.
4-channel: 13.9 in (35.31 cm) h by 19.0 in (48.26 cm) w by 21.0 in (53.34 cm) l.

Weight.....2-channel: 54 lb (24.5 kg).
3-channel: 79 lb (35.9 kg).
4-channel: 104 lb (47.2 kg).

Type of enclosure.....Totally enclosed.

Audible noise.....None.

Cooling required.....Natural convection.

Nominal conditions.....Normal factory ambient temperature, humidity, and barometric pressure.

Service Conditions

Ambient temperature range..... Per MIL-E-16400F, class I, -54 to +65 °C operating, -62 to +75 °C nonoperating; or MIL-E-5400G, class 1A, -54 to +55 °C operating, 30 minutes at +71, -62 to +85 °C nonoperating.

Ambient humidity range..... Per MIL-E-16400F or MIL-E-5400G.

Altitude..... Per MIL-E-5400G, 0 to 30,000 feet operating.

Shock conditions..... Per MIL-S-901C, grade A, class I, type A, equipment hard mounted. Per MIL-E-5400G, equipment hard mounted or mounted with vibration isolators.

Vibration..... Per MIL-STD-167, type I, equipment hard mounted. Per MIL-E-5400G, curve 1, equipment mounted with vibration isolators.

EMI..... Per MIL-STD-461/462/463 except as follows:
(1) CW may exceed CE01 limit 20 dB.
(2) Broadband may exceed CE01 limit 35 dB.
(3) Broadband short duration may exceed CE03 limit 20 dB from 20 kHz to 200 kHz.

Airborne noise..... Per MIL-STD-740, grade A, type 3.

Enclosure..... Totally enclosed per MIL-STD-108D.

Electrical Characteristics (For Each Channel)

Power source..... 115 volts $\pm 10\%$, 400 Hz $\pm 5\%$, 1 phase, or 28 Vdc

Exhibit 17-12

MT TAMALPAIS IM PRODUCTS

750 DATA 13,10,0.01,
 750 DATA 134.35, 132.95, 134.45, 128.15, 132.8, 133.5, 133.7, 126.8,
 755 DATA 132.45,
 770 DATA 122.0, 121.5, 122.5, 122.3,
 780 DATA 290.5, 269.1, 307.3, 281.5, 319.1, 285.4, 335.6,
 785 DATA 269.3,
 790 DATA 243.0, 255.4
 800 END

?BASIC IMP5 100

RUN

N	FREQ(I)	FREQ(J)	FREQ(K)	IM-PRODUCT
7	132.95	134.45	133.7	133.7
7	132.95	122	128.15	126.8
7	132.95	122	126.8	128.15
7	132.95	122	132.45	122.5
7	132.95	122	122.5	132.45
7	132.95	121.5	132.45	122
7	132.95	121.5	122	132.45
7	128.15	126.8	132.95	122
7	123.15	126.8	132.45	122.5
7	128.15	126.8	122	132.95
7	128.15	126.8	122.5	132.45
7	133.5	122.5	133.7	122.3
7	133.5	122.5	122.3	133.7
7	133.5	269.3	133.7	269.1
7	133.5	269.3	269.1	133.7
5	133.7	132.95	0	134.45
5	133.7	134.45	0	132.95
7	133.7	122.3	133.5	122.5
7	133.7	122.3	122.5	133.5
7	133.7	269.1	133.5	269.3
7	133.7	269.1	269.3	133.5
7	133.7	269.3	121.5	281.5
7	133.7	269.3	281.5	121.5
7	132.45	122	132.95	121.5
7	132.45	122	121.5	132.95
7	132.45	122.5	132.95	122
7	132.45	122.5	128.15	126.8
7	132.45	122.5	126.8	128.15
7	132.45	122.5	122	132.95
5	122	121.5	0	122.5
5	122	122.5	0	121.5
1	121.5	0	0	243
7	121.5	122.5	122	122
7	121.5	281.5	133.7	269.3
7	121.5	281.5	269.3	133.7
7	122.5	269.1	122.3	269.3
7	122.5	269.1	269.3	122.3
7	122.3	269.3	122.5	269.1
7	122.3	269.3	269.1	122.5
7	269.1	255.4	281.5	243
7	269.1	255.4	243	281.5
7	281.5	243	269.1	255.4
7	281.5	243	255.4	269.1
3	243	121.5	0	121.5

```

7PUNCH IMP5
TYPE G AND TURN ON PUNCH
G
50 REM IM PRODUCTS AT VHF & UHF
55 REM N1/N2= TOTAL NUMBER OF VHF/UHF FREQUENCIES RESPECTIVELY
60 REM D=CLOSEST DESIRED TO UNDESIRABLE FREQ SPACING ALLOWED
80 REM I,J,K CORRESPOND TO THE ORDER OF FREQUENCIES LISTED
90 REM M=EQUATION NUMBER IN LINES 180-240
100 DIM F(50)
105 PRINT "M","FREQ(I)","FREQ(J)","FREQ(K)","IM-PRODUCT"
110 READ N1,N2,D
120 LET N3=N1+N2
130 FOR I=1 TO N3
132 LET J=I
134 LET K=I
136 LET L=I
140 READ F(I)
141 LET F(J)=F(I)
142 LET F(K)=F(I)
143 LET F(L)=F(I)
145 NEXT I
150 FOR I=1 TO N3
151 LET P=2*F(I)
152 LET M=1
153 GO SUB 245
154 LET P=3*F(I)
155 LET M=2
156 GO SUB 245
160 FOR J=1 TO N3
180 LET P=F(I)+F(J)
183 LET M=3
185 GO SUB 245
187 IF J<=I THEN 210
189 LET P=F(I)+F(J)
192 LET M=4
195 GO SUB 245
210 LET P=2*F(I)+F(J)
212 LET M=5
215 GO SUB 245
227 FOR K=1 TO N3
228 IF J<=I THEN 242
229 IF K<=J THEN 237
230 LET P=F(I)+F(J)+F(K)
233 LET M=6
235 GO SUB 245
236 IF J<=I THEN 242
237 LET P=F(I)+F(J)+F(K)
240 LET M=7
241 GO SUB 245
242 NEXT K
243 NEXT J
244 NEXT I
245 LET C=1
246 IF P<0 THEN 270
247 FOR L=1 TO N3
250 LET T1=ABS(P-F(L))
255 IF T1>D THEN 265
260 IF T1<=D THEN 263
263 GO SUB 600
265 NEXT L
270 RETURN
600 IF M<3 THEN 604
601 IF J=I THEN 650
602 IF K=I THEN 650
603 IF K=J THEN 650
604 LET Y=F(K)
605 LET Z=F(J)
606 IF M=>3 THEN 608
607 LET Z=0
608 IF M=>6 THEN 610
609 LET Y=0
610 PRINT M,F(I),Z,Y,P
650 RETURN
750 DATA 13,10,0.01,
760 DATA 134.35,132.95,134.45,128.15,132.8,133.5,133.7,126.8,
765 DATA 132.45,
770 DATA 122.0,121.5,122.5,122.3,
780 DATA 290.5,269.1,307.3,281.5,319.1,285.4,335.6,
785 DATA 269.3,
790 DATA 243.0,255.4
800 END

7OFF
OFF AT 11:47:12 07/07/76
COMPUTE SEC. - 89.9
CONNECT MIN. - 31

```

Exhibit 17-13

IM GENERATION PROGRAM
(3rd Order Products)

APPENDIX
GLOSSARY OF ACRONYMS

A/G	air/ground
ACK	acknowledge signal
ARSR	Air Route Surveillance Radar
ARTCC	Air Route Traffic Control Center
ARTS	Automated Terminal Radar System
ASAP	Air Separation Assurance Program
ASR	Airport Surveillance Radar
ATC	Air Traffic Control
ATCRBS	Air Traffic Control Radar Beacon System
ATCT	Air Traffic Control Tower
ATIS	Automatic Terminal Information Service
BCAS	Beacon Collision Avoidance System
BUEC	Backup Emergency Communications
CAS	Collision Avoidance System
C.D.	clearance delivery
CMLR	Communication Microwave Link Repeater
CMLT	Communication Microwave Link Terminal
CST	Combined Services Tower
DABS	Discrete Address Beacon System
DF	direction finder
DSB-SC	double sideband suppressed carrier
ECAC	Electromagnetic Compatibility Analysis Center

ECOM	En Route Communications
EFAS	En Route Flight Advisory System
E/G	engine/generator
ERAD	En Route Radar
ESEC	En Route Secondary Radar Beacon
FAA	Federal Aviation Administration
FDAT	flight data
FSS	Flight Service Station
HAT	high altitude
IFR	Instrument Flight Rules
ILS	Instrument Landing System
IPC	Instrument Positive Control
LASS	Line Automatic Switching and Sensing System
LAT	low altitude
LCOT	Link Communication Terminal
LNKR	Link Repeater
LOS	line of sight
LRCO	Limited Remote Communication Outlet
LRR	Long Range Radar
MSL	mean sea level
MTBF	mean time before failure
MTBO	mean time between outages
MTR	mean time to restore service
MTTR	mean time to repair
NAFEC	National Aviation Facilities Experimental Center
NAS	National Aviation System
NAVAID	navigation aid
NOTAMS	notices to airmen
PIREPS	pilot reports
PTT	push to talk

RAPCON	Radar Approach Control
RCAG	Remote Center Air/Ground Facility
RCO	Remote Communications Outlet
RCVR	radio receiver
RFI	radio frequency interference
RML	Remote Microwave Link
RMLR	Remote Microwave Link Repeater
RMLT	Remote Microwave Link Terminal
RO	receive only
RQ	request for retransmission
RTR	Remote Terminal Transmitter/Receiver
SFO	Single Frequency Outlet
SMC	switch, monitor, and control
SS-1	Selective Signal-1
TACAN	Tactical Air Navigation
TCOM	Terminal Communications
TELCO	Telephone Company
TR	transmit/receive
TRAD	Terminal Radar
TSEC	Terminal Secondary Radar Beacon
TWEB	Transcribed weather broadcasts
UCR	Unsatisfactory Condition Report
UHF	ultra high frequency
UNICOM	Airport Advisory Stations
UTG	Upgraded Third Generation
VFR	Visual Flight Rules
VHF	very high frequency
VOR	VHF omni-directional radio range
VORTAC	co-located VOR and TACAN stations
VSS	Voice Switching System
W/C	water closet

XMTR	radio transmitter
ZLC	Los Angeles ARTCC area
ZOA	Oakland ARTCC area
TRACON	Terminal Radar Approach Control