

Unclassified

SECURITY CLASSIFICATION OF THIS PAGE (When Data Entered)

12

ADA 042716

REPORT DOCUMENTATION PAGE		READ INSTRUCTIONS BEFORE COMPLETING FORM
1. REPORT NUMBER TOP-1-2-510 ✓	2. GOVT ACCESSION NO.	3. RECIPIENT'S CATALOG NUMBER 9
4. TITLE (and Subtitle) U. S. ARMY TEST AND EVALUATION COMMAND DEVELOPMENT TEST II (EP) - COMMON TEST OPERATIONS PROCEDURES "LOGISTICS-OVER-THE-SHORE"	5. TYPE OF REPORT & PERIOD COVERED Final	
7. AUTHOR(s)	6. PERFORMING ORG. REPORT NUMBER	
9. PERFORMING ORGANIZATION NAME AND ADDRESS U. S. Army Aberdeen Proving Ground (STEAP-MT-M) Aberdeen Proving Ground, Maryland 21005	8. CONTRACT OR GRANT NUMBER(s)	
11. CONTROLLING OFFICE NAME AND ADDRESS U. S. Army Test and Evaluation Command (DRSTE-ME) Aberdeen Proving Ground, Maryland 21005	10. PROGRAM ELEMENT, PROJECT, TASK AREA & WORK UNIT NUMBERS AMCR 310-6	
14. MONITORING AGENCY NAME & ADDRESS (if different from Controlling Office)	12. REPORT DATE 11 2 March 1976	13. NUMBER OF PAGES 32
	15. SECURITY CLASS. (of this report) Unclassified	
16. DISTRIBUTION STATEMENT (of this Report) Approved for public release; distribution unlimited.		
17. DISTRIBUTION STATEMENT (of the abstract entered in Block 20, if different from Report)		
18. SUPPLEMENTARY NOTES		
19. KEY WORDS (Continue on reverse side if necessary and identify by block number) *Beach Operations Materials Handling Equipment Cargo Loading Adaptability Mobility Waterway Equipment Load Adaptability Transportability Logistics-Over-The-Shore (LOTS) Vehicle, Tracked Marine Equipment Vehicle, Wheeled *New		
20. ABSTRACT (Continue on reverse side if necessary and identify by block number) Provides a method for evaluating the LOTS capabilities of military equipment including cargo and vehicles. Describes subtests for watertightness, vehicle stability, marine transport, maneuverability, beaching capabilities, fording operations, soils trafficability, beach mobility, seashore exposure, performance under adverse conditions (high wind, heavy rain, high waves, beach obstacles), and safety evaluation. Discusses site and facilities selection, safety factors, and other test planning requirements; human factors and maintenance evaluations. (over)		

DDC
AUG 11 1977
C

DDC FILE COPY

041 754

Unclassified

SECURITY CLASSIFICATION OF THIS PAGE(When Data Entered)

Block 20 (Cont'd)

Applies to movement of cargo and vehicles, including towed, self-propelled, and by carrier, over the shore between ocean transportation and shoreside facilities without benefit of port facilities; loading/unloading onto and from landing craft, amphibians, other transporters, helicopters, storage areas, and transfer points.

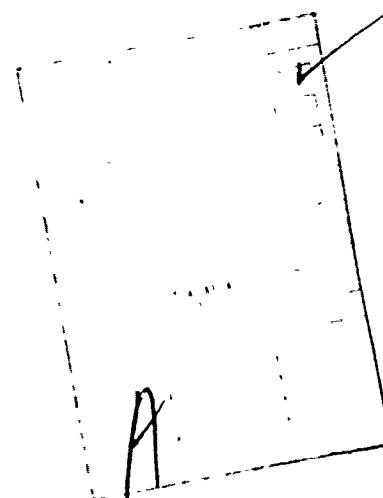

Unclassified

SECURITY CLASSIFICATION OF THIS PAGE(When Data Entered)

US ARMY TEST AND EVALUATION COMMAND
TEST OPERATIONS PROCEDURE

DRSTE-RP-702-100

*Test Operations Procedures 1-2-510

2 March 1976

AD No.

LOGISTICS-OVER-THE-SHORE

	<u>Paragraph</u>	<u>Page</u>
Section I. GENERAL		
Purpose and Scope	1	2
Background	2	2
Equipment and Facilities	3	3
II. TEST PROCEDURES		
Preliminary Activities	4	3
Suggested Tests for Various Types of Equipment	5	4
Watertightness	6	4
Vehicle Stability (Swimmers and Amphibians).	7	6
Marine Transport	8	7
Maneuverability (Swimmers and Amphibians).	9	10
Beaching Capabilities (Swimmers and Amphibians).	10	11
Fording Operations	11	13
Soils Trafficability (Self-Propelled Vehicles	12	16
Beach Mobility Test (Self-Propelled Vehicles).	13	17
Seashore Exposure.	14	22
Adverse Conditions	15	23
Airlift by Helicopters	16	23
III. SUPPLEMENTARY INSTRUCTIONS		
Test Planning.	17	24
Preparation for Test	18	25
Safety of Test Operations.	19	26
Safety Evaluation.	20	26
Human Factors.	21	26
Maintenance Evaluation	22	27
APPENDIX A. REFERENCES		A-1
B. MARINE ENVIRONMENTAL FACTORS AND VESSEL CHARACTERISTICS		B-1

*This TOP supersedes MTP 2-2-520, 30 July 1970.

SECTION I
GENERAL

1. Purpose and Scope. This TOP provides guidance for preparing detailed test plans to evaluate the logistics-over-the-shore (LOTS) capabilities of military equipment, both cargo and vehicles, whether towed, self-propelled, or moved by carrier.

a. Test objectives are to determine conformance of the test items to Required Operational Capabilities (ROC), Development Plans (DP), or other criteria. The scope of testing will be selected from section II of this TOP to satisfy the requirements for the particular test item and test type. For DT II tests, the scope will depend on the criteria stated in the governing ROC or DP. The subtests described may also be used for DT III and customer type tests, using criteria established by contractual documents, specifications, or test directives. This TOP is a basic guide for preparing detailed test plans, and procedures may require modification to suit specific items.

b. All tests specified herein are not applicable to all test items. The test planner should be selective to include only those tests needed to satisfy the requirements document for the specific item to be tested. Applicable data obtained from previous or similar tests and data that can be obtained by concurrent testing with other test phases should be considered to avoid duplication and reduce the scope of testing. LOTS testing has great potential for concurrent testing with other test phases, and joint schedules should be developed whenever possible with the following subtests: Transportability (TOP 1-2-500), Large Cargo Containers (TOP 10-2-214), Container Handling and Accessory Equipment (TOP 10-2-215), Fording (TOP 2-2-612), Waterway Equipment (TOP 9-2-251), and Containers and Pallets (TOP 10-2-080).

2. Background.

a. In accordance with AR 70-44 and AR 70-47, Engineering for Transportability, the Army has established a program to insure that newly developed or procured items meet the LOTS requirements.

b. A LOTS operation is the movement of cargo and personnel over the shore between ocean transportation and shoreside facilities without the benefit of port facilities. This includes:

- (1) Unloading cargo and personnel from ships into landing craft, amphibians, or other transporters, or by helicopter.
- (2) Moving cargo and personnel from ship to shore.
- (3) Unloading landing craft at beaches.

2 March 1976

TOP 1-2-510

(4) Towing equipment with a floating capability from off shore through the surf and over the shore.

(5) Forging materiel through the surf from landing craft to the shore. May involve special vehicles with both water and land propulsion systems (amphibians) or standard vehicles modified to float and withstand calm water operations (swimmers).

(6) Unloading amphibians or transporters at transfer points.

(7) Moving cargo from landing craft to temporary storage or segregation areas or to destination.

(8) Unloading at storage areas or transfer points.

Carriers may include landing craft, barges, lighters, amphibians, helicopters, air cushioned vehicles, or other transporters. LOTS testing normally is conducted as a part of, or in conjunction with, the transportability evaluation of the test item which includes surface (highway, rail, and marine) and air (fixed and rotary wing) transportability.

c. Although most military equipment used by ground forces is designed primarily for use on land, it is often exposed to fresh or sea water fording, wetting, or immersion, and beach crossings. It is therefore necessary to incorporate into the equipment certain features that enable it to withstand these environments.

The LOTS environment imposes on test items conditions of a severity and variety not likely to occur in other test environments, including a combination of salt air, sea water, sun, wind, surf, blowing sand, and rain; shipside buffeting, turbulent seas and surf, and various terrain obstacles. The environment is apt to be potentially the most damaging of the entire materiel distribution cycle. To counteract such an environment, materiel must possess special characteristics as to corrosion resistance, configuration, strength, watertightness, ruggedness, and mobility.

This TOP contains minimum procedures for evaluating the LOTS capabilities of equipment and transported cargo including tests for the fordability, flotation, beach mobility, and exposure resistance of towed and self-propelled tactical vehicles and equipment; and for the minimum immersion requirements for combat and support equipment normally installed on, or carried in, open vehicles, trailers, or transporters.

3. Equipment and Facilities. Equipment and facilities are indicated in the applicable paragraphs below.

SECTION II TEST PROCEDURES

4. Preliminary Activities.

a. Before an item is subjected to a LOTS subtest it normally will

2 March 1976

have already been subjected to many other subtests and inspections. The TOP/MTP dealing with the specific item under test should be referred to for preliminary activities. Other factors pertinent to the LOTS test are described in the following TOP's/MTP's:

<u>SUBJECT</u>	<u>PUBLICATION NO.</u>
(1) Initial physical inspection	1-2-504
(2) Technical inspection	2-2-500
(3) Training and familiarization	10-2-501
(4) Preliminary operations	2-2-505
(5) Installation of kits	2-2-707
(6) Lifting and tiedown attachments	1-2-500
(7) Fording	2-2-612

b. Safety of personnel is a major consideration in every operation dealing with loading and offloading (para 19).

c. When expedient and practical, the transported materiel is observed at the original shipping sites to obtain the maximum transportability shipment data concurrently with necessary transportation operations associated with the test. Such data are used to minimize further testing.

5. Suggested Tests for Various Types of Equipment. Full-scale LOTS operations for various types of equipment normally consist of the subtests shown in table 1.

6. Watertightness.

6.1 Objective. To determine whether the test item is capable of exposure to water without any appreciable seepage or leakage.

6.2 Standards. Complete exclusion of water or as permitted by governing criteria.

6.3 Method.

a. Before placing the test item in the water, the test item is physically inspected to insure that all seals, ports, hull compartments, gearboxes, wheel ends, fuel tanks, valves, and oil sumps are free of moisture, and accesses to them are tightened to insure that leakage or seepage does not occur. Once this has been accomplished, the test item is placed in calm water of sufficient depth to expose these critical working and contact points to water. Floating equipment is loaded to insure hull submersion to the design minimum freeboard. The test item is left exposed to the water for a specified period not less than 10 minutes.

Table 1 - Suggested Lots Tests

Type of Equipment	Subtest														
	Preliminary Activities	Watertightness	Vehicle Stability	Marine Transport	Maneuverability	Beaching Capability	Fording Operations	Soils Trafficability	Beach Mobility	Seashore Exposure	Adverse Conditions	Airlift (Helicopters)	Safety Evaluation	Human Factors	Maintenance Evaluation
Self-Propelled Vehicles (Swimmers) and Amphibians . . .	X	X	X	X	X	X		X	X	X	X	X	X	X	X
Self-Propelled Vehicles (Non-Swimmers)	X	X	X	X	X		X	X	X	X	X	X	X	X	X
Towed Vehicle or Equipment	X	X		X			X			X	X	X	X	X	X
Cargo or Equipment Carried as On-Board Cargo	X	see para 6.3b X		X						X	X	X	X	X	X

b. Deck-loaded equipment and cargo are subjected to a water hose test. All doors, ports, hatches, or other openings are closed tightly. A stream of water is applied over all the exterior surfaces. To simulate the effect of seaspray driven by gale force winds and to detect potential points of leakage, the following parameters are used: 1 kg/cm² (15 psi) pressure in conjunction with the use of a 12.7-mm (1/2-inch) inside-diameter nozzle held at a distance of 1.5 m (5 feet) from the part under test with a rate of movement over the exterior of approximately 100 mm (4 inches) per second. (This is a more severe test than the rain test in TOP/MTP 2-2-815).

c. Upon completion of testing, a visual inspection of internal areas of the test item opposite the applied water is conducted. Oil or fuel samples are also obtained from the critical areas protected by seals or closures, such as the fuel tanks, oil sumps, driving gearbox, differential, and wheel ends. These samples are visually examined, and any seepage or water contamination observed in the internal areas or in the samples is recorded, as required.

2 March 1976

d. At the conclusion of the watertightness test and visual inspection, an operational check of the equipment is conducted to insure that the exposure to water has not affected the functional or operational capabilities of the equipment.

6.4 Data Required. Data will include the length of the exposure period in minutes, depth of water immersion in inches, severity and location of leaks, and the amount of water or contamination encountered in the fuel tanks, oil sumps, driving gearbox, differentials, wheel ends, and hull compartments. The ability of the test item to respond to operational readiness upon completion of the watertightness test is evaluated, measured, and recorded.

6.5 Analytical Plan. Measured and observed data are compared against predetermined criteria for analysis of performance. Oil samples are examined for evidence and extent of seepage or leakage. All data are analyzed for evidence of deterioration or contamination and tabulated to show critical areas affected. Narrative analysis is used when failures or deficiencies occur.

7. Vehicle Stability (Swimmers and Amphibians).

7.1 Objective. To determine the stability characteristics of the test item.

7.2 Standards. Freeboard, inclination, and righting moments shall be as specified, and as a minimum shall insure sustained flotation of the vehicle.

7.3 Method. Stability characteristics are determined by locating the center of gravity, metacentric height, and transverse radius of gyration of a floating vehicle.

a. To determine the center of gravity for items capable of suspension with available lifting facilities, procedures of TOP/MTP 2-2-800 are used, employing either suspension or reaction methods, and the location recorded with respect to the baseline, centerline, bow, and stern. For large vehicles, an inclining experiment is used to determine the vertical center of gravity and metacentric height. The experiment with the vehicle or item afloat is accomplished by positioning a known weight at known distances on either side of the vehicle's centerline, producing various angles of heel. Detailed procedures for determining in water the center of gravity, the metacentric height, the transverse radius of gyration, and the natural period of roll are contained in TOP 9-2-251.

b. After the above static tests are completed, operational stability is determined by performance tests in water as described in TOP 9-2-251. For land, operational mode, specific tests for gradeability and stability on side slopes may be selected from TOP/MTP 2-2-610. Various loading and

2 March 1976

TOP 1-2-510

overloading patterns are used as required by test directives. Once safe stability has been determined, operation may be continued to determine other characteristics such as vehicle overload capacity, adequacy of cargo tiedowns, or effects of cargo on vehicle operating characteristics.

7.4 Data Required. Data will include the specific gravity of the flotation water, depth of water, measured center of gravity, amount of weight used, calculated value of metacentric height, and transverse radius of gyration. Operational data are observed and recorded.

7.5 Analytical Plan. Theoretical design data are analyzed and checked against the measured, observed, and computed test data for verification of characteristics. Computed results are, if possible, compared with the stated requirements to determine whether acceptable limits of stabilization have been achieved.

8. Marine Transport.

8.1 Objective. To determine how well the test item can be loaded and transported on a marine vessel and offloaded in LOTS operations.

NOTE: If marine transportability tests are being conducted in accordance with TOP 1-2-500, data from such tests will be used in lieu of conducting further tests.

8.2 Standards. The test item must be able to be satisfactorily transported in accordance with procedures in TB 55-100, TM 55-500, and TM 55-513 and the requirements of the ROC/DP.

8.3 Method.

a. Loading From Dock. The test item is properly prepared for marine transport as prescribed in the technical manuals. The test item, with rated highway payload unless specified otherwise, is loaded aboard an LST, LSD, or other transport vessel in calm weather by either driving (if self-propelled) over the vessel's main ramp in a forward direction or being lifted (for non-self-propelled) off the dock and placed in the ship's hold for storage and shipment. The vehicle should be driven on and off in both directions to identify any limitations or restrictions. Once the test item has been placed in the recommended storage area, it is secured for transport using ship's equipment and personnel. Diagrams of all tiedown methods and equipment used are recorded.

b. Transport and Offloading Onto Carrier. Once the test item has been secured, it is transported from the dock to the offshore test site. Upon arrival at the test site, the test item is driven off or lifted out of the hold area of the ship and placed in a waiting landing craft, lighter, or amphibian for movement to shore. The lifting operation includes the internal movement to the square of the hatch, the attachment of required slings and lifting devices, and crane lift out of the hold and into the cargo compartment of the carrier. Observations include description of

relative motions between the ship and carrier, extent and effects of pendulation, ease and effectiveness of tagline and crane control, use of or need for fendering systems, any damages incurred, and unduly difficult conditions encountered.

c. Offloading at Beach. Offloading at the beach will differ depending on the type of equipment (see table 1). Swimmers and amphibians are tested as described in paragraph 10 and self-propelled and towed equipment as described in paragraph 11. For nonmobile items (such as containers) the specific conditions for offloading are investigated, to include those of both wet and dry ramp debarkations, transfer by crane, or hauloff by forklift or transporter. The test includes at least five offloading operations of each type investigated. The item to be offloaded is rigged and attached, then lifted, slung, or transferred to a stable position on the beach accessible by required further transfer media. The operation is observed and described to include data on equipment used, safety of the operation, difficulties encountered, and limitations of landing craft and MHE involved. Observed procedures to enhance offloading operations are documented.

d. Adverse Weather. A followup test in adverse weather is usually required (para 15).

e. Compatibility Study. A paper study is made of the various transport vessels, commercial roll-on/roll-off, SEABEE, and LASH vessels; amphibious equipment; and landing craft by comparing the physical dimensions of the test item with the appropriate dimensions of the various vessels or equipment. This is done to determine the compatibility of the test item with the equipment and the vessel on which it will be loaded, tied down, and transported. The study encompasses the physical aspects of roll-on/roll-off maneuvering, loading, and tiedown arrangements in SEABEE or LASH barges or other marine vessels, and the most expedient method of transportation is recommended based on the information available (app. B, table 3).

8.4 Data Required. The data will include identification and physical dimensions of the transport vessel, landing craft, and test item; length of time and number of people required to secure the test item for movement, offload it onto the landing craft and then the beach; lift capabilities of marine vessels, location of stowage, adequacy of lifting and tiedown provisions, hatch clearances; identification of equipment used in loading and offloading, including lift heights and sling radii, as applicable; test item and ramp angles of approach, departure, break, and crest;* condition of ramp (wet or dry) and length of surf zone for offloading; difficulties encountered in any of the operations, an assessment of safety aspects, and additional data indicated in 8.3 a through e above. Data on water depth, height of waves, and wind velocity and direction relative to the axis of the ship are also recorded. (*For information on gradeability, angles of break and crest, and lateral stability, see fig. 1.)

2 March 1976

TOP 1-2-510

Angles of Approach and Departure

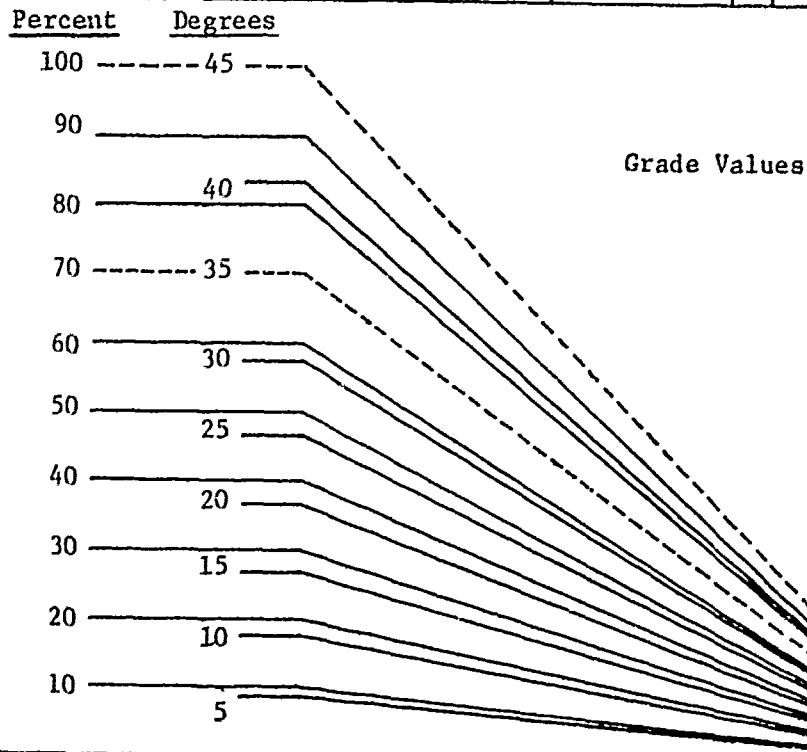
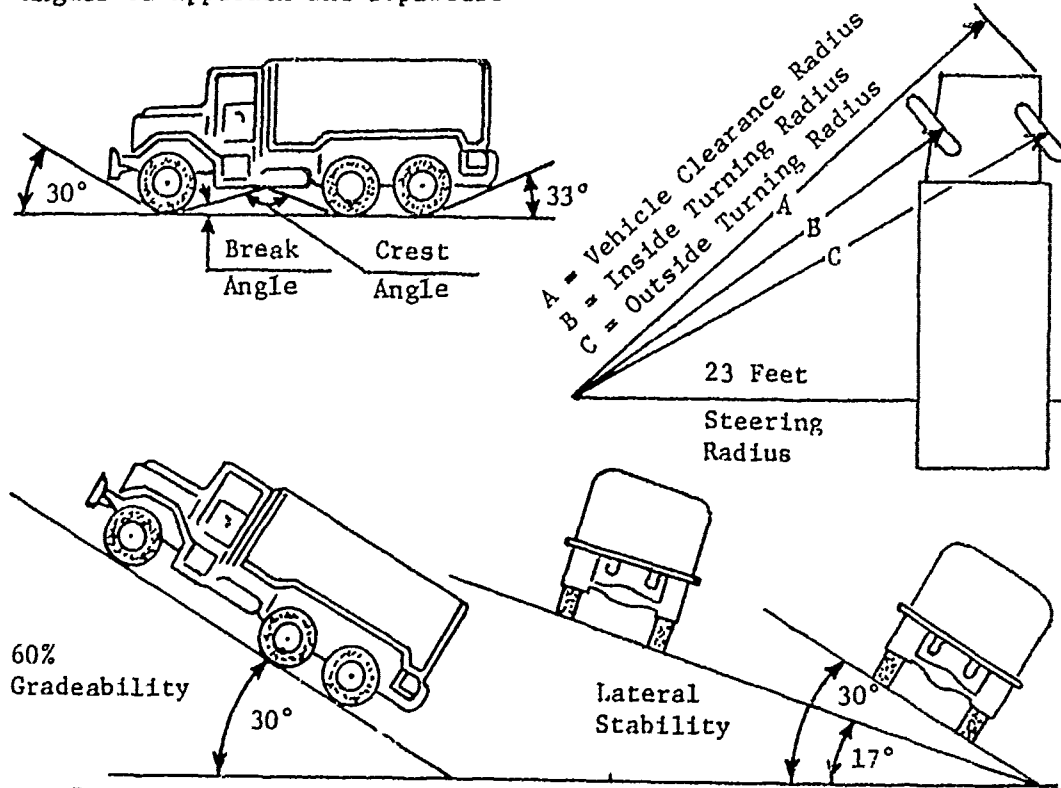

Figure 1. Vehicle Maneuverability Characteristics.

2 March 1976

8.5 Analytical Plan. The various data are summarized to show critical measurements, displacements, and interferences. Supporting photographs, sketches, and diagrams are included as appropriate. Narrative analysis is used for failures and other test incidents.

9. Maneuverability (Swimmers and Amphibians).

9.1 Objective. To determine the maneuverability characteristics of the test item at shipside.

9.2 Standards. The vehicle will be capable of movement and transport of cargo through the extent of sea specified by the requirements documents.

9.3 Method.

a. Tests required by TOP 2-2-501, Amphibious Vehicle Characteristics are conducted prior to initiation of any testing required by paragraphs 9 and 10 of this document.

b. Swimmer test items, without payload, are offloaded in calm weather from an LSD, LST or cargo vessel. The ability of the test item to be adequately controlled as it maneuvers away from the transporting vessel and to maintain a course as it swims toward shore is determined. The ability of the test item to maneuver alongside a cargo vessel and to hold position while lifting slings are attached is determined. The ability of the test item to maneuver into position and negotiate the ramp of the LST or swim into the LSD is determined. The above tests are also conducted using the maximum safe payload for water operations as determined by previous tests.

c. The amphibian test item after being unloaded from the transporting vessel (LSD, LST or cargo ship) is maneuvered alongside a cargo ship and held in position at the ship's side while cargo is loaded and unloaded. Conventional or specified fendering and line handling provisions are used to assist control of the item and guard against damage. On the test item's loading cycle, swing cargo is spotted, set down, and secured as required, and the test item maneuvered away from the ship. On the test item's unloading cycle the test item is brought alongside the ship and cargo is rigged and lifted free of the test item. The load/unload cycle is repeated a minimum of five times. A narrative description of the operations is prepared, to include assessment of adequacy of maneuverability, control, and safety of personnel, cargo, and test item.

d. When offloading of a test item is accomplished by use of a landing ship ramp or by flotation from a well deck, a minimum of five offloading and reloading maneuvers are completed with the test item under its own power. Its ability to approach and negotiate the ramp or well deck opening is observed and recorded.

e. A followup test in adverse weather may be a requirement (para 15).

2 March 1976

TOP 1-2-510

9.4 Data Required. The data will include general steering response, turning and maneuverability characteristics, time required to complete maneuvers, maximum payload used while conducting each test, wave height and direction, wind velocity and direction, current velocity and direction, observed capability of the item to maneuver and maintain position alongside the ship during loading and unloading operations, and loading and unloading times. Techniques employed by operators to approach and negotiate the ramp of the LST or to enter the well deck of the LSD will be noted.

9.5 Analytical Plan. The various data are summarized to show critical measurements, speeds or payloads, times, and difficulties encountered. Supporting diagrams are included as appropriate. Performance is assessed against that required by the criteria documents.

10. Beaching Capabilities (Swimmers and Amphibians).

10.1 Objective. To determine the capability of amphibians and swimming vehicles to negotiate the surf and beach area during typical LOTS landing operations.

10.2 Standards. The vehicle will sustain movement and transport under conditions specified by the requirements documents.

10.3 Method.

a. The beaching site is selected to include the gradient, general beach profile, predominant surface material, and surf conditions for which the vehicle is designed. The approach to the beach is surveyed to insure freedom from damaging underwater obstacles.

b. Operations are made with the test item in light condition and in minimum surf. Operations are performed to determine capability of the vehicle to negotiate the surf zone when both approaching the beach and departing from the beach. All operations are completed with the vehicle heading in a perpendicular direction to the surf line. Not less than five landings are made without a payload to determine the best speed to negotiate the surf zone in either direction. During these operations the slope of the beach is measured and recorded, and the ease of ingress and egress of the test item is rated (fig. 2). The test is repeated with the vehicle loaded to the maximum payload for safe water operation.

c. The above test is repeated under progressively greater surf conditions until the maximum surf the vehicle can safely negotiate is determined. The optimum speed for safe negotiation of each surf condition (in each direction) is observed. On landing, the cargo is discharged as appropriate either on the beach or inland. The vehicle may or may not be required to negotiate a beach mobility course, based on its prescribed mission.

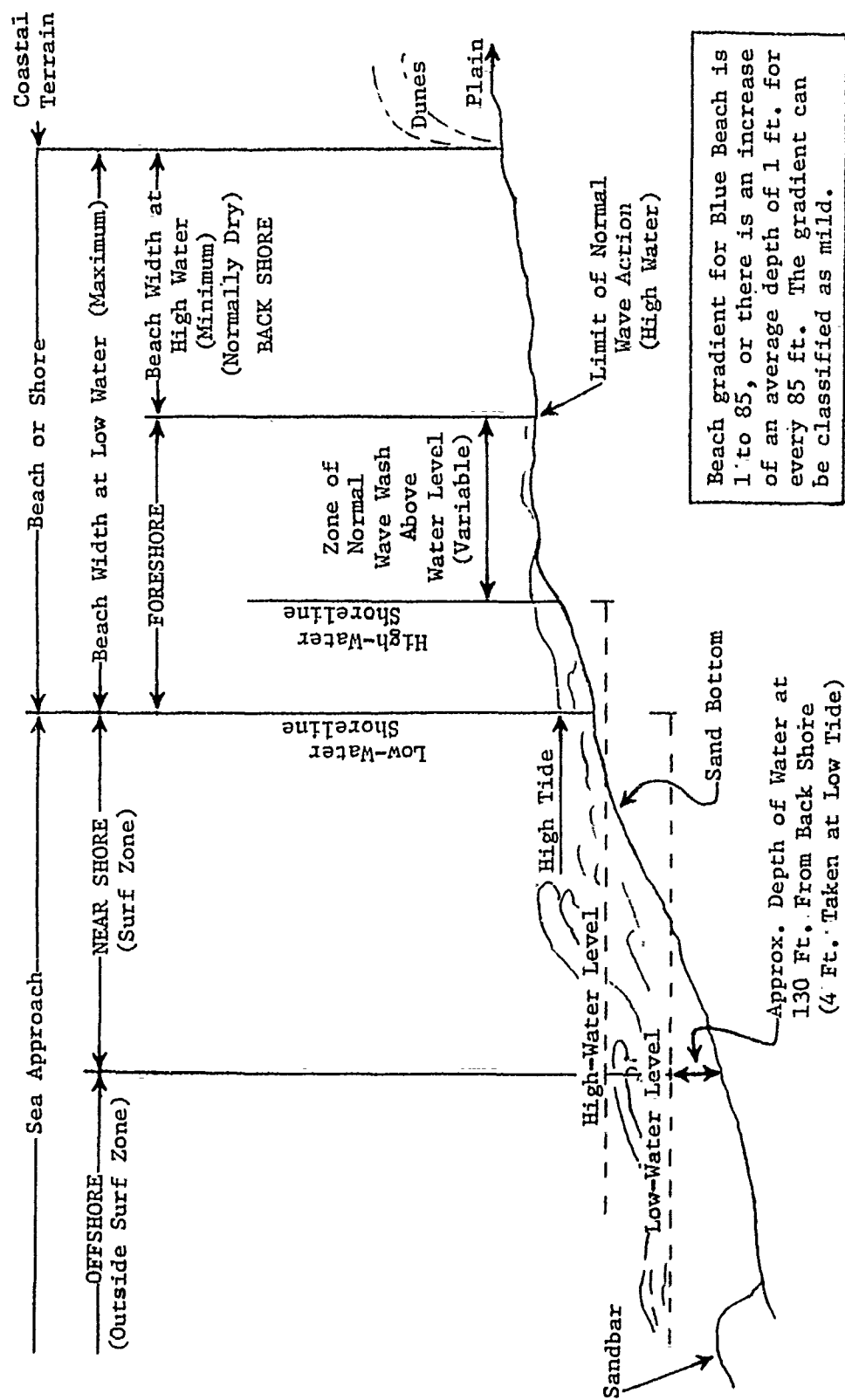

Beach gradient for Blue Beach is 1' to 85, or there is an increase of an average depth of 1 ft. for every 85 ft. The gradient can be classified as mild.

Approx. Depth of Water at 130 Ft. From Back Shore (4 Ft. Taken at Low Tide)

Schematic Profile Only - Not to Scale

Figure 2. General Beach Profile, Fort Story, Va.

2 March 1976

TOP 1-2-510

10.4 Data Required. Recorded data for each landing include wind direction and velocity, wave height, vessel heading and loading, surf and current conditions, and approach speed. Beach gradient and description are recorded. Observation is made of ability to maintain course and achieve intended landing site, tendency to broach, adequacy of power, and effects of propeller wash. Ramp angles and clearance for cargo egress are noted. Inspection is made for noticeable hull damage and adverse effects from vibration, impact, or overheating.

10.5 Analytical Plan. Performance is analyzed against requirements to determine whether the test criteria have been met.

11. Fording Operations.

11.1 Objective. To determine whether the test item is capable of fording operations encountered during LOTS operations.

NOTE: Before any ocean tests are conducted, controlled fording tests should be conducted in accordance with TOP 2-2-612. The results of such tests should be considered and accepted insofar as applicable to preclude further testing.

11.2 Standards. The test item must meet the requirements of the ROC/DP and be able to perform as indicated in TB 34-9-30, TB 34-9-31, and TM 55-500.

11.3 Method. The following guidance has been established as the minimum fordability requirements for tactical vehicles and towed and self-propelled guns. Further guidance and fording characteristics for combat or tactical vehicles are given in TOP 2-2-612. Safety considerations are covered in TOP 2-2-612 and in paragraph 19.

a. Shallow Water Fording. Shallow fording tests are usually possible without any advance preparation of the vehicle. When this is not reasonable, preparation should be within the capabilities of the crew using the handtools usually carried on the vehicle. Once the vehicle is ready for fording, it is driven onto an appropriate type landing craft (LCU, LCM-8, LCM-6, etc.), retrograded approximately 1/4 mile from the shore, and then beached where the landing craft will disembark the test item at locations selected by the test director. All locations must provide wet ramps. Water depths are as specified in table 2. At least five debarkations are conducted at five different locations. The total fording depth includes vehicle sinkage depth and wave height. During all embarkation and debarkation operations the landing craft ramp angles, vehicular angles of approach and departure, surf and sea conditions, and duration and variation of high and low tides are determined and recorded. Comments on the ability of the test item to be discharged as cargo for movement from ship to shore are recorded.

b. Preparation for Deep Water Fording. The test item is prepared for deep water fording as prescribed in the technical manuals or as recommended by the test agency with concurrence of the developing activity. If a combat or tactical vehicle, towed or self-propelled gun, or other

self-propelled equipment does not have water-crossing or a deep fording capability by built-in waterproofing, floating, or swimming, it is mandatory that deep water fording kits be provided. All kits must require only minimum field modification of the vehicle and be capable of being installed by the vehicle crew in minimum time. Kits must provide the capability of deep fording for at least 15 minutes in fresh or salt water to the depths specified in table 2. The vehicle should be operated in water to nominal depths to assure suitable functioning of the fording kit prior to operating in deep water.

Table 2 - Equipment Fordability Requirements

Type Vehicle	Fording Requirements	Remarks ¹
All Combat and Tactical Vehicles	Shallow water fording, 30 inches	This is the minimum fording requirement for these vehicles.
Tactical Vehicles Under 2-Ton Payload	Not less than 20 inches	
Light Tanks and Armored Vehicles	39 Inches	May be forded to maximum extent possible.
Tanks and Other Armored Vehicles	42 Inches	May be forded to maximum extent possible.
Fully Inclosed Armored Vehicles	To maximum depth practical consistent with adequate freeboard	Freeboard is measured from top of commander's hatch opening or turret.
All Other Vehicles	60 Inches	Except trailed loads.
All Trailers or Towed Guns	Complete submergence	Alternatively, these pieces of equipment should be capable of flotation. ²
Equipment Normally Installed or Carried in Open Type Vehicles	At least 60 inches fording depth required	Such equipment will, if necessary, be waterproofed separately for complete submergence in fresh or salt water without materially affecting its operation. ³

See footnotes on following page.

2 March 1976

TOP 1-2-510

¹For further information see TB's 34-9-30 and -31.

²If flotation equipment is fitted, the vehicle should be capable of operation on land without detracting from its normal performance.

³This requirement will not apply to equipment that receives adequate protection from the vehicle in which it is installed.

c. Deep Water Fording. After the test item has been prepared for deep water fording, it is loaded onto an appropriate type landing craft, retrograded approximately 1/4 mile from the shore, and then beached where the landing craft will disembark the test item at locations selected by the test director. At least five debarkations are conducted at five different beach locations. Depths include vehicle sinkage depth and wave height. During all embarkation and debarkation operations the landing craft ramp angles, vehicular angles of approach and departure, and surf and sea conditions are determined and recorded. Comments on the ability of the test item to be discharged as cargo from ship to shore are recorded. After all fording operations, oil samples are obtained from the differentials, crankcase, transmission, wheel ends, engine and hull compartments, and hydraulic system to measure the amounts of water contamination or seepage into these components. Inspection will include the removal of wheel cylinder assemblies, if necessary, to determine the presence of corrosion.

d. Materials Handling Equipment (MHE) Fording. When specified for rough terrain forklift or cranes, or similar MHE, the test item is forded parallel to the beach shoreline, in water depths to design limitations (see table 2, "all other vehicles"), for at least five fording operations of not less than 15 minutes duration each, or for such continuous period as specified for the particular item. As part of this operation, or as part of the beach mobility test (para 13.3a), forklifts designed to unload landing craft repeat the immersion and drying cycles (permitting 15-minute drying) to subject axles and transmissions to maximum thermal and pressure variations. The extent of the cycling is in accordance with the specified endurance requirements of the forklift.

e. Post-Operation Check. At the conclusion of the fording operations a functional check of the test item is conducted to insure that the fording operation has not affected the operational capability of the equipment. Vehicles and self-propelled weapons must be capable of driving 25 miles or 2 hours (whichever occurs first) after leaving the water before any of the additional preparatory means to fording which may have been necessary are removed. Deep water fording covers and stacks, however, which are likely to cause overheating of the engine or other assemblies, should be capable of being jettisoned within 5 minutes after the vehicle crosses the shore. Self-propelled and towed weapons and the main armament of vehicles must be capable of use immediately after fording. All other equipment not included in the above categories must be capable of accomplishing its assigned mission, as prescribed in the ROC/DP or other applicable documents, upon exiting the water. If each test item is capable of performing the assigned mission, the test is considered successful. Common fording depths for ordnance type materiel are shown in table 2.

11.4 Data Required. The test data will include the depth of fording, height and duration of waves, wind velocity and direction, ease of entry onto and exit from landing craft, amount of contamination encountered during fording operations, the ability of the test item to negotiate the landing craft ramp, time spent in fording operations, and the environmental conditions encountered.

11.5 Analytical Plan. Collected data are analyzed to determine whether the test item is capable of movement as on-board cargo for LOTS operations and transport by landing craft without weight or dimensional restrictions, damage, deformation, or deterioration; and the degree to which the test item completes its intended mission.

12. Soils Trafficability (Self-Propelled Vehicles).

12.1 Objective. To determine the capability of the test item to negotiate specific types of soils existing in the beach area during LOTS operations.

12.2 Standards. The vehicles must be able to traverse with full load the soils in a beach area. The test site should include soils with cone index ratings of 60 to 80 (average values) for 0- to 6-inch layers, and gradients of at least 15 percent.

12.3 Method. Vehicles are first tested for soft-soil mobility in accordance with TOP/MTP 2-2-619. This test may be conducted in conjunction with other tests. Primary activities are accomplished as follows:

a. Soil Characteristics. Soils are described in TM 5-330. Using a soil trafficability test set, the soil trafficability characteristics are measured in and around the beach area and the principal areas of operation. A wide variety of soil conditions is important, particularly the most severe such as sand dunes and marsh areas. The number of measurements to be taken are determined by range of soil strengths and the general uniformity of the area. The cone penetrometer is the principal instrument used in evaluating soils trafficability. When the cone is forced into the ground, the proving rings are deformed in proportion to the force applied. The amount of force required to move the cone slowly through given planes is indicated on the dial inside the ring. This force is considered to be an index of the shearing resistance of the soil and is called the cone index (CI) of the soil at that depth. Further test and soil sampling procedures can be found in TM 5-330, chapter 9.

2 March 1976

TOP 1-2-510

b. Beach Profile and Gradient. The slopes and dimensions of each different soil condition are recorded (diagram), to include shallow under water areas extending back to the farthest point at which the ocean has influenced the soil.

Upon completion of the beach profile, gradient, and soil characteristics measurements, the test item is required to traverse the various soils. Tests are accomplished to determine the types of soils the test item is capable of negotiating and the CI at various depths in these soils. Emphasis is placed on the ability of the test item to perform its mission in these soils while loaded to its rated load, and to lesser loads if not successful with a full load. Towing is provided and measured if necessary.

12.4 Data Required.

a. Preliminary data will include selected routings, high and low water levels, beach width at high and low water levels, beach gradient, height of waves, surf conditions, distance from shore at which breakers form, type of bottom, beach and soil classification, and the estimate of the maximum operational capabilities of the test item in the area of operations (i.e., number of passes over a specific area and the maximum slope the vehicle can successfully negotiate).

b. Test data will include number of measurements taken, tire inflation pressures, payload carried, range of soil types and strengths, dial readings at intervals, CI of soil, critical layer of soil, samples taken, moisture content; remolding index and rating cone index if applicable, and soil depth at reading; and the computed vehicle cone index (VCI).

12.5 Analytical Plan. Collected data are analyzed to determine the minimum soil strength in which the test item can operate in and around the level beach areas, the maximum slope the vehicle can negotiate, and the towing force in soft areas.

13. Beach Mobility Test (Self-Propelled Vehicles).

13.1 Objective. To determine whether the test item is capable of repeatedly performing its stated mission in the beach area.

13.2 Standards. The test item must be able to perform the mission defined in the ROC/DP over beach terrain as typified in figures 2 and 3.

13.3 Method.

a. The beach mobility test is arranged to provide mission tasking of the test item as to both mobility and endurance. The test course is

2 March 1976

selected to include interface with the landing craft at the beachhead, to traverse representative distance over different types of beach terrain (surf, dunes, sand trails, etc.), and to include appropriate maneuvering and spotting operations at transfer and storage points. Typical mobility test courses are shown in figures 3 and 4. The figures show representative distances for a container-handling forklift. Table 2 of TOP 1-2-500 shows typical mileages for off-road transportability testing for various equipment. These should be studied in conjunction with the characteristics of the item to be tested.

b. Prior to conducting actual beach mobility operations, the trafficability of the beach and surrounding area is measured and recorded as described in paragraph 12.

c. Upon completion of the soil trafficability tests, the test item negotiates the beach mobility course in both a loaded and unloaded condition for the prescribed duration or cycles. All MHE are required to negotiate at least 25 miles of sand trails, wet sand, sand dunes, marsh areas (if available), mud areas, and hard surface roads, all of which may be found in a forward beach or resupply area. All other combat or tactical vehicles or self-propelled weapons are required to negotiate a beach mobility course consisting of wet sand, mud, sand trails, sand dunes, and hard surface roads found in the beach area for 25 miles or for 2 hours (whichever is less) after leaving the water before any of the additional preparatory means to fording which may have been necessary are removed. Subsequently, cyclic operation is continued to the extent necessary to check vehicle endurance. If mission-type operations are required in conjunction with beach traverse, operations such as shown on figure 5 may be arranged.

13.4 Data Required. The test data collected will include the types of beach terrain encountered, the length of each type, beach characteristics, soils characteristics (CI, moisture, density, grain size), type of equipment tested, ability of the test item to negotiate in and around the beach area, mechanical failures, mobility problems encountered, tire inflation pressure, payload carried, and slope gradients negotiated. Problems experienced in completing the test item's intended mission will be reported.

13.5 Analytical Plan. Collected test data are analyzed to determine the capability of the test item to perform and negotiate the beach area without degradation of the operational capability, malfunction or damage.

2 March 1976

TOP -2-510

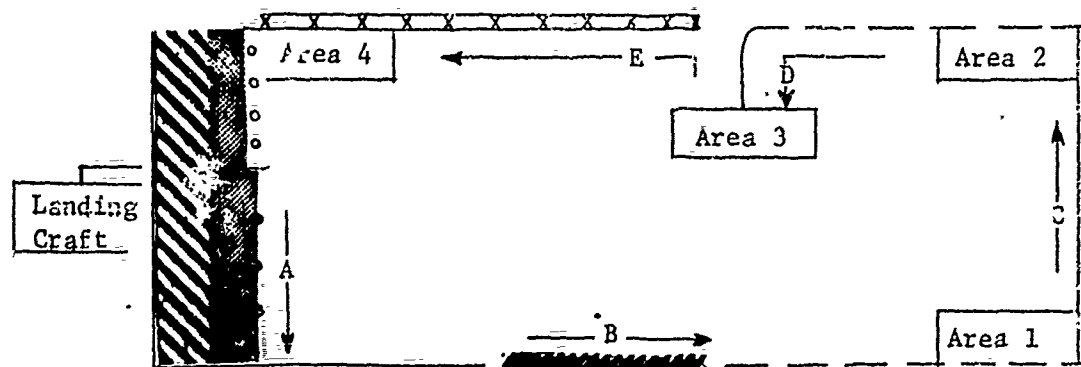

Legend	Description	Approximate Distance		Area No.	Remarks
		ft	m		
	Beach area			1	Empty containers will be stacked 3 high.
	Surf (max. 60 in. or less)			2	Loaded containers will be stacked 2 high.
	Wet sand - beach area	500	152	3	Loaded containers will be loaded on S&P trailers.
	Dry sand operations	250	76	4	Breakbulk palletized cargo will be stored.
	Sand dunes	100	30		
	Sand trails	100	30		
	Combination mud, sand trails, and sand dunes	300	91		
	Shallow fording 30 in. or less	100	30		
	Hard surface roads	600	183		

PROCEDURE: The test item is required to transport loaded/empty 20-foot MILVAN cargo containers and 40-foot commercial or military containers from the beach and landing area to various storage areas, negotiating the terrain and distances shown. An empty cargo container is taken to storage area 1 via avenues A and B. The test item deposits ("stores") the container and returns to the landing craft using avenues C, D, and E. The test item then lifts a loaded MILVAN container and transports it from the beach over avenues A, B, and C to storage area 2 and deposits it. The test item returns to the landing area using avenues D and E and picks up another loaded container. The test item carries this container to area 3 via avenues A, B, C, and D and places it on a waiting stake-and-platform trailer. After the load has been secured, the test item returns to the landing area via avenue E and picks up a 463L pallet. The pallet is transported over the mobility test course to storage area 4 where it is stacked. The test item again returns to the beach and landing area. Upon completion of this event, one test cycle is considered complete.

Figure 3. Beach Operation and Mobility Test Course Without Slopes.

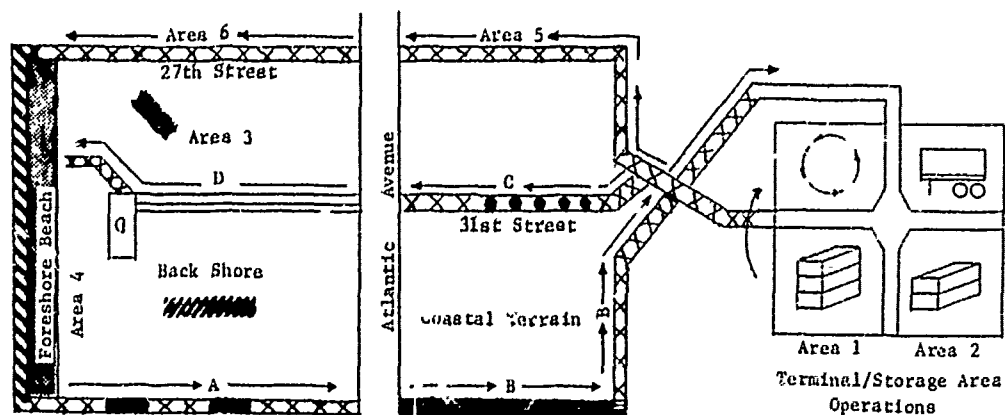

Schematic Plan of Test Course

Legend	Description	Approximate Distance		Area No.	Remarks
		ft	m		
XXX	Sand trails	2100	640	1	Empty containers stacked three high.
Diagonal lines	Surf	700	213	2	Loaded containers are loaded on S&P trailers.
Dotted pattern	Combination, mud, soft soil	400	122	3	5% slope creeping accomplished.
Solid black	Slope climb (hard-surfaced)	28	8.5	4	Beach-negotiation phase.
Wavy pattern	Combination gravel-sand	850	259	5	Sand trail entrance to 10% slope, approach speed 3 mph.
Horizontal lines	Hard-surfaced roads	425	129.5	6	27th street ramp, 10% slope negotiation.
Wavy pattern	Sand dunes	15	4.5		

PROCEDURE: The test item is required to transport loaded and empty 20-foot MILVAN cargo containers from beach area 4 to the storage area in the rear. The empty and loaded cargo containers are taken to the storage area via avenues A and B. (Avenue A is located on a meandering course among and over dunes which present maximum slope-climbing performance exposures for the test vehicle.) The test item stores the containers in the storage area and returns to the beach using avenues C and D. The test item then lifts another MILVAN container and transports it from the beach to the storage area as stated before. In areas 1 and 2 of the storage area the loaded and empty containers are stacked as in the schematic above. Loaded containers are also loaded onto container chassis and stake-and-platform trailers. Each round trip to the beach is considered as one test cycle. The test item is required to negotiate the terrain and distances shown above approximating a minimum of 1.5 miles (2.4 kilometers).

NOTE: This course is predicated on the Fort Story, Va. site. Some tests may require operation on beaches of both stable and marginal strengths and may require similar plans at other sites, such as Little Creek or Camp Pendleton, Va.

Figure 4. Beach Operation and Mobility Test Course With Slopes.

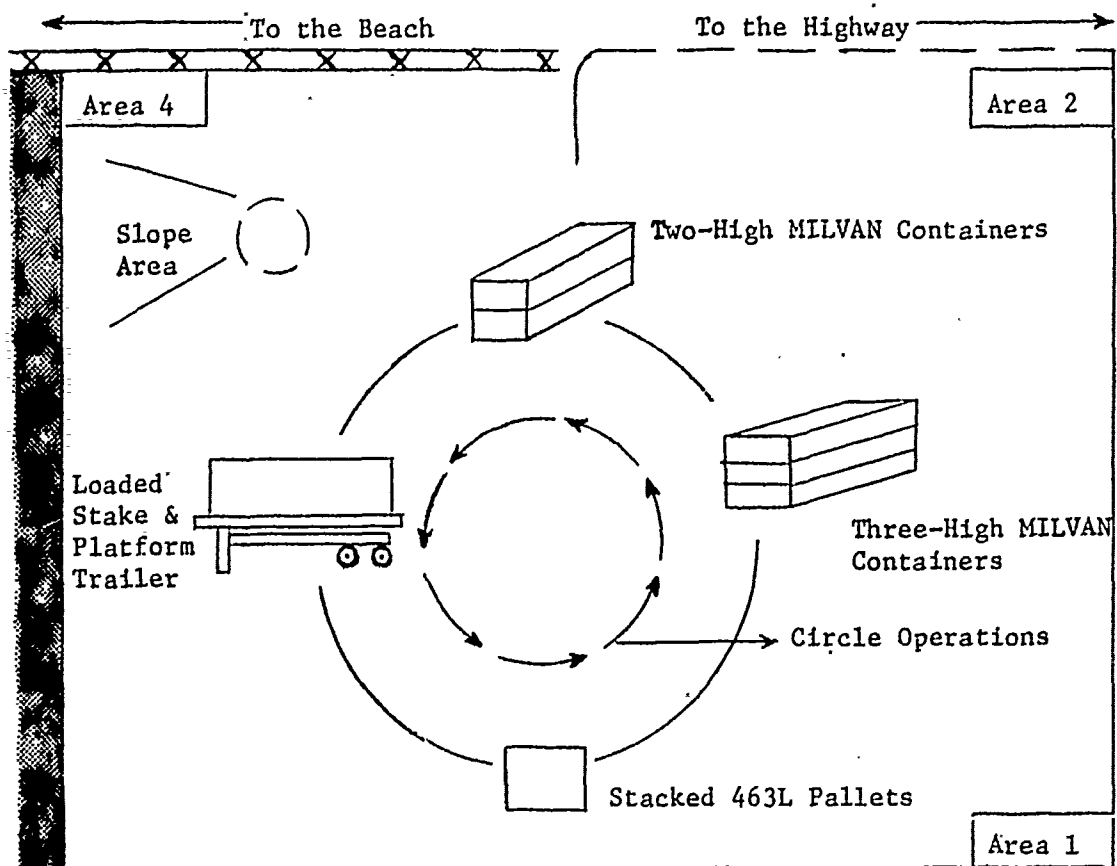

PROCEDURE: After completing the mobility test courses, the test item is required to perform loading/unloading, stacking, and storage operations as required in a forward storage area. The test item proceeds from the storage area to the previously mentioned areas of operation using the previously specified trails. Upon reaching each individual area, the test item lifts or picks up an item and returns it to the storage area where it is stacked in the position specified by the test director. During the terminals handling test the test item is required to stack empty containers three high and loaded containers two high, load trailers, traverse longitudinal slopes of 25% and side slopes of at least 15%, and perform left and right turning and full circle maneuvers. (Unequal load distribution and stability are not evaluated during these operations but will be evaluated as described in para 7.)

Figure 5. LOTS Terminals Operations.

14. Seashore Exposure.

14.1 Objective. To determine the degree to which the test item can resist the corrosive effects of an ocean-front environment, and the effect of corrosion on performance.

14.2 Standards. None.

14.3 Method.

a. Data available from any prior chamber testing are reviewed to determine the capabilities of the test item to resist the effects of salt fog, blowing sand, rain, solar radiation, or similar tests under controlled conditions. The test item is prepared for salt water exposure in accordance with the prescribed procedures in the technical manuals prior to initiation of testing.

b. Actual exposure testing at the ocean exposed site to determine the effects of combined environments includes one or both of the following procedures:

(1) During all phases of LOTS testing, the test item is left exposed to the salt-laden atmosphere in the vicinity of the beach at all times. During the entire period the test item is not washed or cleaned but is given a visual inspection at least every other day. Upon completion of all LOTS testing, the test item is subjected to a maintenance teardown inspection to the degree appropriate to assure that deterioration or degradation has not occurred.

(2). The test item is driven into the surf and thoroughly wetted with sea water up to permissible fording depth. Above-water portions of the vehicle normally subject to wetting by spray or turbulence are wetted by splashing. Without benefit of washing, the item is parked and left exposed to the natural salt-laden and blown-sand environment for 10 days. The item is then inspected and operated to determine the effects and extent of any deterioration.

14.4 Data Required. Data will include identification of any areas, internal or external, that are not corrosion resistant; the effectiveness of any corrosion protective coatings such as paint, grease, etc; the ability of any electrical or mechanical components to operate satisfactorily during or after natural or artificial exposure; the effectiveness of gaskets and seals after exposure; location and extent of corrosion; material degradation that will affect the service life of the equipment; the length of time the equipment was operated when under exposure; time of exposure; and any variation from satisfactory levels established by previous performance tests.

14.5 Analytical Plan. The performance of the test item is analyzed against operational requirements to determine whether operational conditions continue to be met.

2 March 1976

TOP 1-2-510

15. Adverse Conditions.

15.1 Objective. To determine the performance of the test item under adverse weather conditions and in beach areas where there are obstacles.

NOTE: Operations under climatic extremes, such as extreme temperatures and humidity, are covered by other TOP's such as 2-2-816.

15.2 Standards. The test item must be able to withstand the adverse conditions stated in the requirements document.

15.3 Method. Testing under adverse conditions is always preceded by testing under relatively placid ocean conditions. Testing is carefully controlled and conducted in accordance with governing safety regulations and procedures. Tests are arranged as practical up to the conditions established by the ROC, DP, or other requirements document. Selected tests may include one or more of the following:

a. Conduct of marine loading/unloading operations (para 9) during wind and sea conditions up to a wind velocity of 7 to 10 knots and wave heights of 3 to 5 feet, or as specified in applicable requirements documents.

b. Conduct of marine operations (paras 9 and 10) during periods of darkness.

c. Conduct of beaching (para 10) and beach mobility (para 13) operations under various conditions of foul weather, high surf, heavy rain, or high winds (rain or sand-laden).

d. Operations involving intentionally imposed obstacles (wet ramp, sinkholes, etc.) or overloaded or degraded equipment conditions.

15.4 Data Required. Recorded data will include description of sea state, terrain, and weather conditions, including current, tide, wave heights, and wind direction and velocity; types and number of runs/cycles, payload weight, and time intervals for vehicle traversals or cargo transported; description of difficulties encountered and indication of damage, deterioration, or degradation of performance or equipment. Failure of equipment at the surf line, and need for salvage, towing, or retrieval are described. Adequacy of, or need for, special safety provisions is determined.

15.5 Analytical Plan. Data are summarized, supported by photographs where appropriate, and evaluated against the limits imposed by requirements documents.

16. Airlift by Helicopters.

16.1 Objective. To determine the capability of the test item to be transported from ship to shore and back by helicopter.

16.2 Standards. The test item must be capable of being airlifted from ship to shore.

16.3 Method.

a. The ship is swing-moored at least 1 mile offshore. The shore dump site must be suitable for helicopter landing. Loads on the ship are preslung and prepared in accordance with TM 55-450 series publications or procedures provided through the developer.

b. Using an appropriate utility or cargo helicopter, a routine sling load operation is conducted observing normal safety procedures. The load is transferred to the dump site at the appropriate speed for stable flight (up to approximately 80 knots depending on load and helicopter used). After arrival at the dump site, the load is disconnected.

c. After the load is visually inspected for damage, it is re-connected to the helicopter and retrograded from the landing zone to the ship. The cycle from ship to shore and return is repeated a minimum of five times.

16.4 Data Required. Collected data will include identification of loads, helicopters, and suspension systems used; sea and wind conditions, ship's pitch and roll; time of helicopter travel, hover, hookup, and release of load; observation of any difficulties experienced in hookup, control, pendulation, rotation, or oscillation of load; effects of relative ship motions; and dependability of suspension equipment.

16.5 Analytical Plan. Collected and observed data are evaluated to determine the flight characteristics of the load being transferred, capability of the load to be airlifted in LOTS operations, relative statistics of air versus surface lifts, and adequacy of provisions and instructions for airlift.

SECTION III SUPPLEMENTARY INSTRUCTIONS

17. Test Planning. DT II test planning requires review of test guidance literature, familiarization with preceding development and test phases, study of test criteria, and selection of appropriate samples, methods, sequence, facilities, and test equipment. Standards for the test phases outlined in section II are given in the applicable ROC, DP, or test directive as indicated in paragraph 1. Risk/cost and safety provisions must be given prime consideration. Data from previous and similar tests must be considered in order to avoid duplication and reduce the scope of further testing.

2 March 1976

TOP 1-2-510

References 8 through 17 (app. A) are particularly pertinent for details needed in planning these tests. Appendixes to TOP 1-2-500 and 10-2-214 also contain information of value in planning.

18. Preparation for Test. Test preparations include the selection of appropriate test sites and facilities (app. B), arrangement for support, review of the safety statement from the developer, and the selection and training of the test team which may involve attendance at new-equipment training courses. Adequate leadtime should be planned in view of the extensive support and training required for some items. The following actions should be accomplished:

a. Select a test site. In selecting an appropriate test site consideration should be given to the following:

(1) Ensure suitable waterway access routes and adequacy of the anchorage area for accommodation of appropriate oceangoing vessels. Record anchorage, berth, classification, and other data as appropriate. (Refer to FM 55-15, ch. 5, sec. III.)

(2) Ensure suitability of the beach site. Record appropriate data and prepare a beach profile diagram as indicated in paragraph 12. For airlift operations, ensure the availability and adequacy of a helicopter landing zone and cargo transfer area.

(3) Ensure that coastal terrain and the shoreside area are suitable for accomplishing the operations. Prepare the beach mobility test courses as indicated in paragraph 13. Record appropriate data concerning roads, trails, or other means of access.

(4) Obtain maps or nautical charts, or prepare sketches as appropriate to depict the area. Indicate location of, and distance between, all key points; include the oceangoing vessel, the beach, and all transfer, unloading, loading, and storage areas.

b. Arrange for the availability of suitable marine craft. The following are usually required:

(1) Oceangoing cargo vessel (LKA, containership, or other suitable vessel having cargo handling capabilities). (Record appropriate data.)

(2) Harborcraft with cargo carrying capabilities. Typical craft include landing craft, amphibians, lighters and towing craft, and air cushioned vehicles.

NOTE: Amphibians or harborcraft as used during the LOTS evaluation should be limited to those expected to be available as TOE materiel.

(3) Observation boat. One or more observers or safety officers are required. The type of craft used for observation purposes is not critical and depends on availability and other local factors and policies.

c. Arrange for the availability of suitable rotary wing aircraft, including the following:

(1) One or more helicopters of appropriate external lift and carry capability.

(2) Slings, pendants, or other suitable or specified suspension systems.

(3) Ground crew familiar with the preparation and handling of external lift procedures, including ship load extraction and control.

d. Arrange for the availability of TOE-authorized shoreside motor transportation. Record appropriate data for the truck(s), tractor/trailer, or other vehicles selected for use.

e. Ensure the ready availability of TOE-authorized MHE at each loading, unloading, and transfer point. Record appropriate information for equipment and materiel at each location.

f. Ensure, as appropriate, the ready availability of other cargo normally shipped with the test item. (Other items of materiel are usually transported concurrently with items of general supplies and equipment, for example.) Record appropriate data concerning the other items.

19. Safety of Test Operations. Maximum safety precautions are exercised during all LOTS operations, with emphasis on those that apply to fording, swimming and flotation, and air delivery tests. Tests are always first conducted in calm weather before any tests are made in adverse weather. All safety procedures prescribed in AMCR 385-100 and referenced TM's are observed. Safety SOP's are prepared before any operations are undertaken.

20. Safety Evaluation. Any existing or potential safety hazard observed is noted, classified as to seriousness, and discussed in the test report. Deficiencies and shortcomings are identified and submitted for action when applicable. Procedures of TOP's/MTP's 2-2-508 and 10-2-508 are followed as necessary.

21. Human Factors. Throughout all testing, observations are made and documented with respect to the simplicity of design inherent in the test item and with respect to ease of handling, maneuverability, mobility, and maintenance by the user in LOTS situations. Procedures of TOP/MTP 10-2-505 are followed as applicable.

2 March 1976

TOP 1-2-510

22. Maintenance Evaluation. Scheduled maintenance is conducted in compliance with instructions provided in the maintenance test package for the test item. Unscheduled maintenance is performed and reported as required. Maintenance analysis as developed by identifying and recording all maintenance and downtime during testing is provided for inclusion with overall test findings. Requirements of TECOM Supplement 1 to AR 750-1 are followed as applicable.

Recommended changes to this publication should be forwarded to Commander, U. S. Army Test and Evaluation Command, ATTN: DRSTE-ME, Aberdeen Proving Ground, Md. 21005. Technical information may be obtained from the preparing activity: Commander, U. S. Army Aberdeen Proving Ground, ATTN: STEAP-MT-M, Aberdeen Proving Ground, Md. 21005. Additional copies are available from the Defense Documentation Center, Cameron Station, Alexandria, Va. 22314. This document is identified by the accession number (AD No.) printed on the first page.

APPENDIX A
REFERENCES

1. AR 55-176, "Logistics-Over-The-Shore Operations in Oversea Areas."
2. AR 70-38, "Research, Development, Test, and Evaluation of Materiel for Extreme Climatic Conditions."
3. AR 70-44, "DOD Engineering for Transportability."
4. AR 70-47, "Engineering for Transportability."
5. AR 310-25, "Dictionary of United States Army Terms."
6. AMCR 385-100, "Safety Manual."
7. TECOM Suppl 1 to AR 750-1, "Maintenance Evaluation During Testing."
8. FM 55-10, "Army Transportation Movement Management."
9. FM 55-15, "Transportation Reference Data."
10. FM 55-50-1, "Transportation Amphibian Operations."
11. FM 55-58, "Transportation Boat Operations."
12. FM 101-20, "United States Army Aviation Planning Manual."
13. TM 5-330, "Planning and Design of Roads, Airbases, and Helicopters in the Theater of Operations."
14. TM 55-450 series (Air Transport of Supplies and Equipment).
15. TM 55-500, "Marine Equipment Characteristics and Data."
16. TM 55-513, "Military Stevedoring."
17. TB 34-9-30, "Fordability and Flotation Agreement."
18. TB 34-9-31, "'Immersion' Proof Requirements for Ground Forces Equipment."
19. TB 55-100, "Transportability Criteria Shock and Vibration."
20. MIL-HDBK 134A, "Military Standardization Handbook: Trucks and Tractors, Tactical (Military) Design Characteristics of."

2 March 1976

TOP 1-2-510

APPENDIX B
MARINE ENVIRONMENTAL FACTORS AND VESSEL CHARACTERISTICS

Table 3 - Characteristics of Amphibious and Landing Craft

Craft	Length	Beam	Cargo (tons) L = long S = short M = metric	Cargo Space Dimensions		Ramp Opening	Remarks
				Length	Width		
LCU 1466 (STD-A)	115 ft 1 in. (35.08 m)	34 ft 0 in. (10.63 m)	150 L (152.40 m)	52 ft 0 in. (15.85 m)	29 ft 6 in. (8.99 m)	14 ft 4 in. (4.37 m)	Fresh water capacity 9,563 gal Additional space forward.
LCH (STD-A)	73 ft 8 in. (22.45 m)	21 ft 0 in. (6.40 m)	53.5 L (54.36 m)	42 ft 9 in. (13.03 m)	14 ft 6 in. (4.42 m)	14 ft 6 in.* (4.42 m)	*Combat equipped troops carried: 20
LARC V	35 ft 0 in. (10.67 m)	10 ft 0 in. (3.05 m)	5 S (4.54 m)	16 ft 0 in. (4.88 m)	9 ft 9 in. (2.97 m)	NA	
LARC XV	45 ft 0 in. (13.72 m)	14 ft 7 in. (4.43 m)	15 S (13.61 m)	24 ft 0 in. (7.32 m)	13 ft 6 in. (4.11 m)	9 ft 0 in. (2.74 m)	
LARC LX	62 ft 6 in. (19.05 m)	26 ft 7 in. (8.10 m)	50 S (54.42 m) 100 S* (90.70 m)	38 ft 8 in. (11.78 m)	13 ft 8 in. (4.16 m)	14 ft 6 in. (4.42 m)	*Can carry in an emergency
LST (Class 1171)	442 ft 0 in. (134.72 m)	62 ft 1 in. (18.92 m)	2,400 L FL* (2,438.40 m) 900 L NB (914.40 m) 500 L NB (508.00 m)	Tank Deck 320 ft 0 in. (97.54 m) Main Deck 208 ft 0 in. (63.40 m)		Inside width: 15 ft 5-7/8 in. (4.77 m) Width between bulkheads: 17 ft 0 in. (5.18 m) Overhead clearance: 17 ft 8 in. (5.38 m)	*FL = Full load NB = Maximum beaching NB = Normal beaching

NOTE: Only lines 7, 8, and 9 are applicable to swell as well as to waves.

1. WIND VELOCITY (KNOTS)	4	5	6	7	8	9	10	20	30	40	50	60	70	75
2. Beaufort Wind and Description	1 Light Air	2 Light Breeze	3 Gentle Breeze	4 Moderate Breeze	5 Fresh Breeze	6 Strong Breeze	7 Mod Fr G*	8 St G*	9 Wh G*	10 Hurricane	11 Storm	12 Hurricane		
3. Required Fetch (Miles) - No. of miles a given wind has been blowing over open water.	50													
4. Required Wind Duration (Hours) - Time a given wind has been blowing over open water.	20													
If fetch and duration are as great as indicated above, the following wave conditions will exist. Wave heights may be up to 10% greater if fetch and duration are greater.														
5. Wave Height Crest to Trough (Feet)	1	2	4	6	8	10	15	20	25	30	40	50	60	
			White Caps Form											
6. Sea State and Description	1 Smooth	2 Slight	3 Mod-erate	4 Rough	5 Very Rough	6 High	7 Very High	8 Precipitous						
7. Wave Period (Seconds)	1	2	3	4	6	8	10	12	14	16	18	20		
8. Wave Length (Feet)	20	40	60	80	100	150	200	300	400	500	600	800	1000	1800
9. Wave Velocity (Knots)	5	10	15	20	25	30	35	40	45	50	55	60		
10. Particle Velocity (Foot/Seconds)	1	2	3	4	5	6	8	10	12	14				
11. WIND VELOCITY (KNOTS)	4	5	6	7	8	9	10	20	30	40	50	60	70	75

*Mod G = Moderate Gale
Fr = Fresh Gale
St = Strong Gale
Wh = Whole Gale

NOTE: Corresponding values lie on a vertical line.

Credit: Dr. Alfred J. Carsola, ASN and Ocean Systems Organization, Lockheed-California Company.

Figure 6. Beaufort Wind Scale.