

AD-A042 717

TEST GROUP (6585TH) HOLLOMAN AFB N MEX
DEVELOPMENT OF ADVANCED SLED VELOCITY MEASURING TECHNIQUES COVE--ETC(U)
JAN 77 E W MELTON

F/G 14/2

UNCLASSIFIED

ADTC-TR-77-6

NL

| OF |

ADA042-717



END

DATE

FILMED

9 - 77

DDC

ADA 042717

12
B.S.

ADTC-TR-77-6

FINAL REPORT

DEVELOPMENT OF
ADVANCED SLED VELOCITY MEASURING TECHNIQUES
COVERING
TRACKSIDE MAGNETIC VMS AND ON-BOARD MAGNETIC VMS

PREPARED BY
E. WAYNE MELTON

DDC
RECEIVED
AUG 11 1977
SECRET
C

TEST TRACK DIVISION
6585TH TEST GROUP
HOLLOMAN AIR FORCE BASE, NEW MEXICO
20 JANUARY 1977

DISTRIBUTION STATEMENT A
Approved for public release;
Distribution Unlimited

ARMAMENT DEVELOPMENT AND TEST CENTER
AIR FORCE SYSTEMS COMMAND - UNITED STATES AIR FORCE

EGLIN AIR FORCE BASE, FLORIDA



AD No. _____
DDC FILE COPY

FOREWORD

In the time period from June 1971 to August 1976 two magnetic velocity measuring systems were developed for the Test Track facility at Holloman AFB, New Mexico. One of these developments replaces the previously used mechanical sensors (breaksticks) in the spot velocity system. The other one is for on-board use to meet high accuracy requirements despite severe environmental conditions encountered during rocket sled runs. This report summarizes these in-house development efforts.

The author expresses his appreciation to Track Instrumentation personnel for their outstanding cooperation in collecting data throughout this program, and to Captain George Pomfret of the Guidance Test Division for his analysis of much of the data.

DISTRIBUTION STATEMENT A
Approved for public release;
Distribution Unlimited

ACCESSION for	<input checked="" type="checkbox"/>
NTIS	W. R. Section <input type="checkbox"/>
DDIC	B. H. Section <input type="checkbox"/>
MANPOWER	
J. S. SECTION	
BY	DISTRIBUTION/ACTIVITY NOTES
Dr. J.	SP. CIAL
A	

(See form 1473)

ABSTRACT

The Test Track facility at Holloman AFB, New Mexico operates rocket sleds for developmental test purposes at speeds into the high supersonic regime. A fundamental requirement on all track missions is a knowledge of instantaneous sled velocity as a function of time and position. This report presents some historical background and discusses the evolution of two basic velocity measuring systems. The distinct purpose and function of each system as well as the need for upgrading the two systems is shown. The development of two magnetic systems fulfilling present day requirements is described and discussed in detail. A brief treatment of data analysis is given and a comparison of the magnetic on-board system with respect to the standard optical system is given.

TABLE OF CONTENTS

	<u>Page</u>
1.0 BACKGROUND	1
1.1 History of VMS Development	1
1.1.1 Other Approaches Sought	2
1.1.2 Laser Doppler	3
1.1.3 Infrared Optical Spot Velocity System	4
1.2 A Summary of the Problem	5
1.2.1 Phase I - Spot Velocity Measuring System	5
1.2.2 Phase II - On-Board Velocity Measuring System	6
2.0 APPROACH - PHASE I	7
2.1 <i>Sensor Considerations</i>	7
2.2 Sensor Selection and Testing	8
3.0 RESULTS - PHASE I	9
4.0 CHARACTERISTICS AND SPECIFICATIONS	10
5.0 SYSTEM OPERATION - PHASE I	13
6.0 APPROACH, PHASE II - ON-BOARD VMS	19
6.1 Test Procedure	19
6.2 Sensor Selection	20
6.3 Design Considerations	22
6.4 Double Pulse Phenomenon	22
6.5 Double Pulse Elimination	25

6.6	Circuit Theory	29
6.7	Metal Effect on Sensors	31
6.8	Sensor Output vs Velocity	33
6.9	System Comparison - Optical versus Magnetic	33
6.10	Rail-Web Magnets	39
7.0	SUMMARY	42
8.0	RECOMMENDATIONS	43
	List of References	45

LIST OF ILLUSTRATIONS

<u>Figure</u>		<u>Page</u>
1	Magnetic Sensor Physical Characteristics	14
2	Trackside MVMS Sensing Unit, Schematic Diagram	15
3	Trackside Sensor-Computer Interface Circuit Diagram	18
4	Sensor Head-Magnet Relationship	21
5	On-Board Electronics Initial Concept - Schematic Diagram	23
6	Signal Generation & Position Reference	24
7	Double Pulse Phenomenon	26
8	On-Board Electronics - Final Design	27
8A	Double Pulse Elimination	28
9	Metal Effect on Sensors	32
10	Sensor Output vs Velocity	34
11	Magnet Placement Device	40
12	Rail-Web Magnetic System	41

1.0 BACKGROUND:

1.1 History of VMS Development: The original length of the test track was 3,500 feet. The velocity measuring system developed for use on this track was known as SLERAN (a contraction for sled ranging). The principal components of the system were ground-fixed installations spaced at 10 foot intervals along the track which served as "position-pulse generating elements" and a "pulse-initiating element" carried on the sled. The method of operation of the first approach consisted of the sequential discharging of capacitors at the respective track stations through gaseous diodes (neon bulbs) which were triggered by a confined radio frequency field from the sled (pulse-initiating element). The resultant signal pulses were propagated via coaxial cable to the track blockhouse where the data were received for processing. There were several weaknesses in this system which affected its reliability. Sled vibration caused frequent malfunctions and failures in the on-board equipment. Also the environment generated by the moving rocket sled caused occasional breakage of the track-side neon bulbs. Humidity during the summer rainy season would affect triggering of the gaseous diodes, thus causing a loss of data.¹

During 1954-55 much effort was devoted to correcting the weaknesses of this first SLERAN system. The track-side SLERAN stations were redesigned. They were modified to use a radio frequency tuned circuit

to detect the energy emitted from the sled-borne unit, thus eliminating the troublesome neon bulbs. These stations were impervious to moisture, rocket motor blasts and the sled-induced vibration and shock environment. The on-board unit was redesigned to be much smaller, lighter, more vibration-resistant and, in general, more reliable.

One fairly radical innovation was introduced in the early part of 1956. It was called an "inverted" SLERAN system.¹ Pulses were generated when a sled-borne tuned RF probe passed a passive track station. These pulses were transmitted by telemetry from the sled to the ground station rather than over track-side coaxial cables.

In December 1955 work began to extend the track to 5,000 feet, and in March 1956 a contract was awarded for a further extension to 35,000 feet.¹ In view of these track extensions and in the course of planning for the forthcoming testing of inertial guidance systems, SLERAN development was discontinued in favor of a system which was operationally better suited to the longer track and which offered a much greater accuracy potential. This new approach was the photoelectric, or "optical," space/time velocity measuring system described below in paragraph 1.3.2. The concept for this system was first conceived in 1955 followed by a period of in-house development effort beginning in 1956 to verify the feasibility of such an approach.

1.1.1 Other Approaches Sought: Concurrently with the in-house development effort three contracts were awarded to study various velocity measuring techniques that would meet the stringent requirements for testing inertial guidance systems on the high speed track. These contracts were awarded to Armour Research Foundation, Chicago, Illinois, Contract

No. AF29(600)-1022; Southwest Research Institute, San Antonio, Texas, Contract No. AF29(600)-1023; and Midwest Research Institute, Kansas City, Missouri, Contract No. AF29(600)-1024. Such possibilities as high speed photography; accelerometer-time measurements; doppler-radar and transponder; space/time-photoelectric, magnetic, and RF coupling were studied in depth. Some form of a photoelectric (light beam) space/time approach was commonly recommended as the most practical and most accurate means of generating the sled position pulse. The study results were reported in final reports submitted by each contractor.^{2, 3, 4}

1.1.2 Laser Doppler: As time went on the search continued for a method of measuring velocity that would provide greater accuracy for testing improved guidance systems, and that would overcome the several disadvantages of the photo-electric system mentioned in paragraph 1.2.2. With this in mind, in 1963 the Track Division embarked on a five year contract program to study and develop a laser doppler technique for measuring velocity. The contract (No. AF29(600)-4136) was awarded to Aircraft Armanents, Incorporated (later AAI Corporation, Cockeysville, Maryland). The contract was extended and modified several times over the five year period. This approach turned out to be unsuccessful. It was finally abandoned when, after actual tests on the track, it was determined the system would be completely unreliable at distances greater than 5,000 feet and even questionable at lesser distances. The prime problem was the inhomogeneous atmosphere close to the ground, which caused a breaking up of the laser beam. Thus, large dark areas resulted in a low signal to noise ratio. Often a complete loss of signal was caused by discontinuities in retro illumination.

Numerous reports were submitted by the contractor outlining progress and results achieved. The final tests were accomplished in-house, resulting in the decision by Test Track personnel to discontinue the project.⁷

1.1.3 Infrared Optical Spot Velocity System: In 1969 an in-house effort was launched to develop an integrated quick look velocity measuring system with inherent computing capabilities. It was proposed to design a system with an accuracy capability of 1 ft/sec at 10,000 ft/sec. The system would provide a positive position identification and would also utilize the same inputs to provide signals to control various track side instruments. Too, the system was intended to possess a programable decision making capability. The technique of deriving control information for track side equipment from instantaneous sled position, velocity, and acceleration would eliminate the need for redundant active tracking devices. One additional design feature desired was a capability for decision making, by velocity profile matching or similar means, to enable or negate later stage firing commands, generate trigger signals for track side cameras and test events, or compensate for off-nominal sled performance.

A basic velocity measuring prototype system consisting of five track stations was designed, fabricated and installed along the track for feasibility tests. A solid state infrared beam was focused onto a 3/8" diameter stainless steel mirror, fixed into the upper portion of the rail web, and reflected back onto a detector. A sled slipper interrupting this beam would initiate a coded position signal. This signal was transmitted to the ground station over coaxial cable to be converted to velocity and related information. The data would also be available for processing into instrument control information as desired.

The prototype worked satisfactorily, but the system was quite complex and to instrument the complete track, even with 208 foot track station intervals, would have been exorbitantly expensive. Also, it would have been a major problem to maintain adequate mirror reflectivity from run to run. In 1971 this approach was abandoned and work began on the magnetic velocity measuring system.

1.2 A Summary of the Problem: This program was designed to improve sled velocity measuring techniques in two distinctly different areas or applications.

1.2.1 Phase I - Spot Velocity Measuring System: A simple rugged system to measure sled position versus time with sufficient accuracy for the majority of routine sled applications without need for related on-board equipment consists of a series of mechanical sensors positioned along the east side of the west rail at 208 foot intervals. The locations are selected to coincide with each 16th interrupter of the electro-optical VMS. Intermediate sensors can be placed at in-between locations if required.

Materials used in earlier testing as pulse-initiating breaking elements were pencil leads and aluminum wire. However, the material used for the past several years consists of thin balsa wood sticks which are coated with aluminum paint to provide a conducting surface. Each stick is broken by direct contact with a particular part of the moving sled, generating an electric pulse by interrupting the current through the stick. The signals thus generated are transmitted to the ground station by means of communications cables and recorded as a function of time with a timing accuracy of about ± 50 microseconds. The recorded data are then processed to yield velocity, acceleration, and other desired information. This system is primarily used for monorail sleds and has successfully performed up to speeds of 8,000 ft/sec.⁵

There were, however, two main drawbacks to this system. First, it was very costly to operate and maintain, requiring up to four man-hours to set the sticks for a particular mission. Secondly, the sticks cause considerable damage to the portion of the sled making contact at hypersonic velocity.

1.2.2 Phase II - On-Board Velocity Measuring System: The standard electro-optical high accuracy velocity measuring system (VMS) has been in operation on the test track since 1958. This system determines sled position as a function of time by means of ground-fixed light beam interrupters. These interrupters consist of bevel-edged stainless steel blade which are positioned at nominal 13-foot intervals along the east side of the east rail of the track. The individual interrupters are periodically surveyed and realigned by means of an invar tape such that the distance between adjacent interrupters is known with a standard error of 0.0005 ft.⁵

Real time measurements are obtained from a sled-borne sensing head which provides a light beam between a light source and a photo-transistor light detector. This beam is broken each time the sensing head passes an interrupter. The output is a series of pulses which is transmitted to the ground station by on-board telemetry, and is recorded and quantized with a standard error of 3 microseconds.⁵ The time versus position data obtained are processed by computer to derive velocity, acceleration and related information as a function of time and of position. This system is primarily used on dual rail sleds for high accuracy requirements. It is, however, employed on certain monorail sleds for special purposes if prearranged conditions can be met.

There are several disadvantages or weaknesses recognized in this system: (1) the light source is subject to failure at the high shock and vibration environment encountered on high performance sled missions; (2) extra pulse generation due to dynamic debris breaking the light beam; (3) extra pulses and considerable lost data when used with congealed water braking; (4) extra pulses when used in the rainfield, or immediately following a natural rain when there is water remaining on or around the rail; and (5) increase in error due to sediment buildup on edge of interrupter blade.

2.0 APPROACH - PHASE I: Since about 90 to 95 percent of all track missions use the track-side spot velocity measuring system, there was greater urgency in developing a replacement for the breakstick method. Because of slipper damage encountered at high sled velocities with the breakstick system, it was essential that any new development was centered around a no-contact type sensor to detect sled position.

2.1 Sensor Considerations: A survey was made of no-contact type sensors. The type which seemed to be the most practical for this application was the electromagnetic sensor - one that would not only respond to the field produced by some fixed magnet but would also respond to the passing of a mass containing magnetic properties, i.e., a sled slipper. Electrical pulses generated in the sensor vary in frequency and voltage magnitude relative to the speed at which the ferro-magnetic mass (slipper) is cutting the magnetic lines of force produced by the sensor magnet. This type of a magnetic pickup or sensor makes use of the "stray magnetic field effect," so that no

provision for a "return" magnetic circuit or path is necessary. Any dynamic discontinuity of magnetic material in the field of the pickup will produce an electrical voltage. The output voltage obtained from the pickup sensor will vary directly with the speed of the passing mass in a linear manner. Varying the clearance, or distance between the sensor and the passing mass, produces an output voltage which varies inversely with the clearance squared. With either factor held constant, the output will be entirely controlled by the other.⁶ In the case of a sled passing the sensors both factors will vary, but the speed variation is, of course, the predominant factor.

2.2 Sensor Selection and Testing: Several different types of proximity sensors were procured, for test and evaluation. These included Electro Corporation, Sarasota, Florida; types 85001, 85002, 3017, 3055-A, 58404, and 58388. Also, a relay plate coil that was on hand was used as a pickup sensor in the original design and tests. This coil and the type 84001 sensor were first used in a sled-borne configuration with magnets along side the track. With this technique, sensors could be given an operational evaluation with only one sensor circuit package.

In the meantime sensor circuits were being designed and tested in the lab. Five packages were fabricated so that several types of sensor pickups could be tested simultaneously in an actual track-side operating environment. Characteristics of concern and under study were: (1) sensor sensitivity to the sled slipper; (2) unit susceptibility to random noise; (3) spacing, slipper size, and speed relationship; (4) system operation with track transmission line complex; (5) system reliability

in rigorous desert environment and extreme operating conditions; and
(6) system reliability under continuous operation in the laboratory.

3.0 RESULTS - PHASE I: After testing the various sensors and associated circuitry over a period of about one year, the type 3017 was selected as the one most promising for meeting the overall requirements. In order to meet the track interference requirements the sensor unit must be mounted at least 3 1/4 inches below the top level of the rail. Thus the sensor - slipper clearance might vary over a range of about 1/4 inch to one inch depending on the size of the slipper for any particular sled. The 3017 unit was sensitive enough to detect a 6-inch slipper at a spacing of one inch down to a velocity of about 40 ft/sec, but not too sensitive to be triggered prematurely by random noise caused by slipper-rail shocks as the sled approaches a sensor.

3.1 When a five unit system was connected into the track-side transmission line complex it was learned that the lines were unsuitable for this purpose. Two pair of lines were required. So in order to operate the system a separate two-pair cable was placed alongside the track and connected into the cable complex leading into the Track Data Center (TDC) where the data was recorded.

3.2 A circuit diagram was provided to a contractor, La Pierre Electronics, Las Cruces, New Mexico, for packaging the unit and four each were procured. These units were potted with a silastic potting compound so that circuit modifications could still be made if necessary. These four units were received and installed in March 1973. They were installed in lieu of four breaksticks and tied in with the breakstick

system for more realistic evaluation. A few circuit modifications were made to improve performance.

3.3 These four prototype units were observed over a period of about three months and found to be working satisfactorily. The modified circuit was submitted to La Pierre Electronics and six additional prototype units procured. The packaging technique was changed in that the circuit board was cast in a hard potting compound (Hysol C9-4183), making it impervious to oil, water, dirt, or corrosive liquids, and protected from all weather elements.

3.4 The six units were received in July 1973 and installed in conjunction with the four units originally procured, to comprise a 10-unit section of magnetic sensors integrated into the breakstick spot velocity system. These ten sensors operated without failure thru June 1974 at which time they were removed in preparation for installation of the complete magnetic sensor system. In July 1974 magnetic sensors were installed in the breakstick brackets from track station 5,258 to track station 35,000.

4.0 CHARACTERISTICS AND SPECIFICATIONS:

4.1 The hot desert environment and rocket motor plume impingement were prime considerations in the design and development of the track-side magnetic sensors. The cable used was 4 conductor, 20 AWG, Belden type 8484. It is weather and heat resistant with a specified operating temperature up to 105°C (221°F). After being exposed to the weather elements over a period of two years there is no sign of deterioration.

4.2 Being cast in the hard potting compound (reference paragraphs 3.3 and 4.13) a hermetic seal is provided, rendering the unit waterproof. A unit was submerged in water for a period of 6 hours in the laboratory and continued to function perfectly. Thus, reliability of the unit in the rainfield or water braking areas was confirmed.

4.3 Two experimental units were operated continuously in the laboratory for a period of 26 months without a failure. One unit was set to trigger the SCR every 10 seconds for the last four months of that period. During this time there were over one million triggering functions. This confirms the high reliability of the sensor circuit.

4.4 Although the cable jacket will withstand heat to 105°C, it can be badly damaged or destroyed by a rocket motor blast. Special precautions need to be taken to protect it. A sleeving of asbestos or teflon has been found adequate for protecting sensor cable located in sled launch areas.

4.5 The magnetic pickup responds to the motion of a mass of ferrous material. The magnitude of the triggering voltage generated is related to the size and speed of the passing mass, its magnetic permeability, and its distance from the sensor. It was learned that the sensitivity of the type 3017 magnetic pickup units can vary quite radically. Each one needs to be checked carefully in the circuit before the unit is potted to see that it is not overly sensitive. A supersensitive unit might be triggered prematurely by noise generated as the sled approaches the sensor. In order to realize a better operating unit one must be careful in selecting the 3017 pickup. In

a normal operating system the sensor reponse should occur at approximately the same relative position of the sled with respect to the sensor. A look at the time differences in the data should verify this. Any unusual discrepancy in a time reading should be investigated. There could be a faulty sensor - one that is responding too early (excessive sensitivity), or possibly too late (inadequate sensitivity).

4.6 The sensor will respond to a small six-inch sled slipper, fabricated from 4130 steel, passing at a speed down to about forty feet per second at a spacing of one inch.

4.7 Once a unit is triggered it is disabled for at least one minute unless manually reset. This feature assures that the sensor will be triggered only by the front slipper, and that it cannot be multi-triggered by subsequent slippers.

4.8 Ten units may be operated in parallel with no interference or interaction between units. (More units may be placed in parallel, limited only by the line's current-carrying capacity and the minimum desired output impedance.)

4.9 Output impedance is 150 ohms, single unit. With ten units in parallel the impedance reduces to 15 ohms.

4.10 Connections:

Red - +10 to 20 VDC (optimum operating point is 15V)

White - signal output

Black - common

Green to white - instant reset

4.11 Each sensor draws about 6.5 ma at 15V.

4.12 Output Pulse:

Rise Time - less than one microsecond

Amplitude - about two volts less than applied voltage.

Duration - about four milliseconds, single unit. This decreases as more units are put in parallel.

4.13 The sensor circuit is cast in Hysol C9-4183, providing a hermetic seal and making it impervious to all potentially damaging elements. Figure 1 shows the physical dimensions of the sensor unit. The sensor may be mounted on a special bracket and then this assembly mounted onto the existing breakstick brackets which are presently located at 208 foot intervals along the east side of the west rail for the first 35,000 feet of track. Particularly for the portion of the track between stations 35,500 and 50,700 the sensor may be cemented to a 1/2 inch thick strip of silicone rubber and then cemented to the web of the rail, maintaining the 3 1/4 inch vertical clearance below the top of the rail.

5.0 SYSTEM OPERATION - PHASE I: With reference to Figure 2 a voltage waveform is generated in L1 as the sled slipper passes thru the magnetic field of the sensor pickup device. This signal is fed to the NS LM111H, voltage comparator. The comparator output pulse is limited by D1 and fed thru D2 to the gate of the SCR. Before the gate signal is applied the SCR is cut off, no current is flowing and consequently the voltage at point P is zero. Once the gate signal is applied the SCR is turned on and current begins to flow. But since the voltage across a capacitor cannot change instantaneously, the total battery voltage (less about a 2 volt drop in the circuit) will appear for an instant at point P (across

MAGNETIC SENSOR MODEL 352E/WM
PHYSICAL CHARACTERISTICS

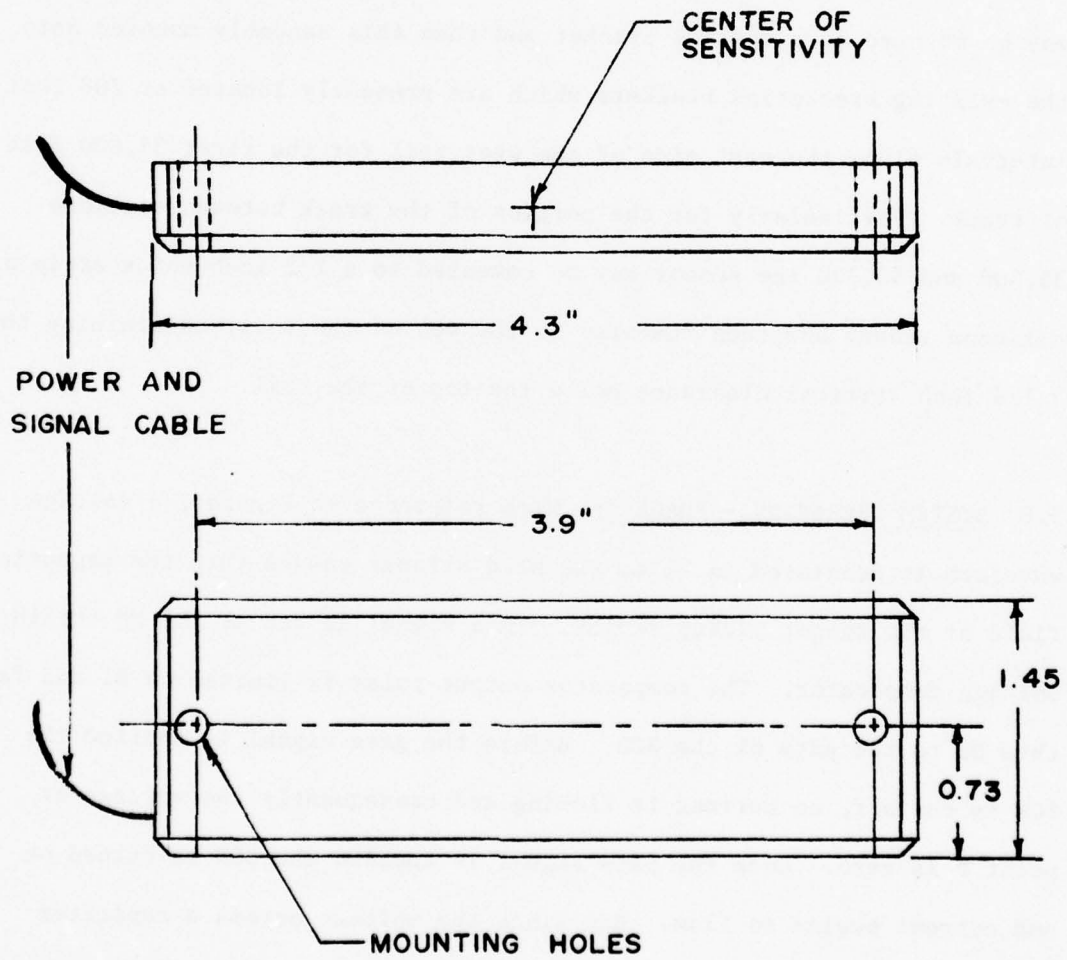

FIG 1

R11). This provides the leading edge of the output pulse which has an instantaneous rise time. Immediately the capacitor, C3, begins to charge and build up a voltage exponentially approaching the battery voltage. Thus the voltage at point P is decreasing in a like manner, completing the output signal pulse. Capacitor C1 prevents oscillation in the comparator circuit and R1 acts as a noise squelch by decreasing sensitivity of the input circuit. The divider, R2-R3, provides a fixed bias of about 0.8V at the negative input terminal of the LM111H. R4, R5, R6 comprises an offset balancing network which, when properly proportioned, assures a stable, positive-going output pulse. Although the comparator circuit would work satisfactorily at the 10-20 volt level, the voltage was reduced to about 6 volts with the dropping resistor R8. This was done in order to reduce the load current to such a level that would permit up to ten units operating in parallel without overloading a transmission line. Dropping the voltage to the comparator does not, of course, affect the amplitude of the output pulse.

Capacitor C2 across resistor R9 acts as a noise suppressor - preventing noise that may appear on the voltage supply line from triggering the SCR and thus producing erroneous output pulses.

Once the SCR has triggered, capacitor C3 is fully charged to the line voltage; this voltage being maintained to maximum level by capacitor C4. As long as C3 is charged above the SCR trigger level, the circuit is disabled. The 2.7 megohm resistor, R10, discharges C3 very slowly and maintains the disable state for approximately one minute. This feature permits only one pulse output as a sled passes over the sensor. Thus additional and unwanted pulses caused by subsequent sled slippers will be inhibited from the output signal line. After about one minute (60 to 75

seconds) from SCR triggering the circuit is automatically reset and ready to receive another trigger pulse. For testing purposes, an instantaneous manual reset capability is provided by switching between the reset (green) and the output (white) lines.

Diode D3 is provided for voltage reverse polarity protection. Diode D4 prevents the charging of capacitor C3 in all units connected in parallel with the one being triggered. Otherwise these units would be disabled and could not be triggered when the sleds reached their respective positions.

The characteristics of the circuit are such that the integrity of the output pulse waveform as described in paragraph 4.12 is maintained after transmission over several miles of land line into the track data center (TDC).

In Figure 3 the basic system is shown in sections of ten sensor units to a single transmission line. Figure 3 also shows how the lines are coupled into a common line feeding the computer. The method of resetting all the units through a reset switch is also shown. There is a voltage control in each line for setting the required voltage on the trackside sensor.

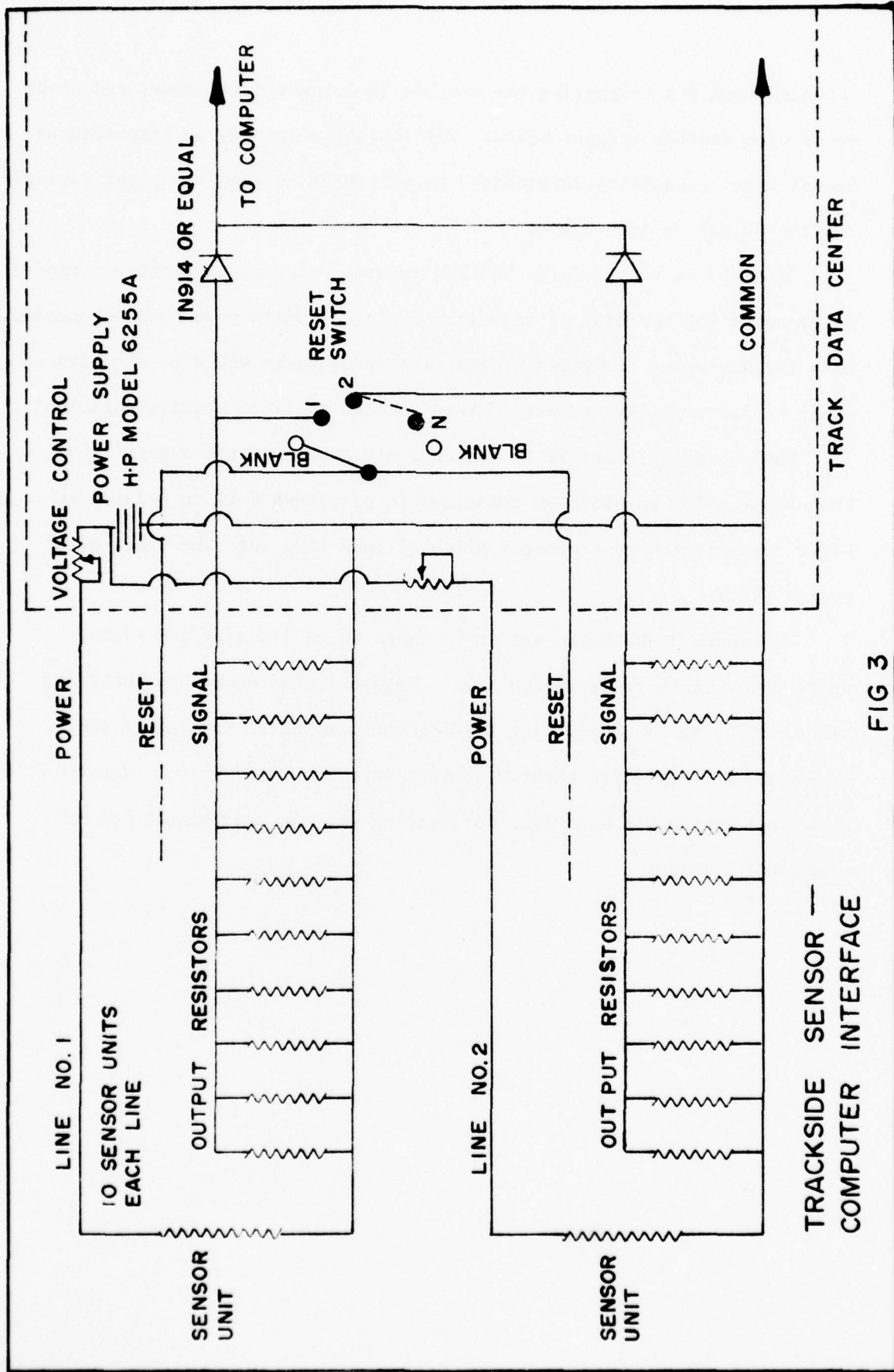

FIG 3

TRACKSIDE SENSOR
COMPUTER INTERFACE

6.0 APPROACH, PHASE II - ON-BOARD VMS: Although a relatively small percentage of track missions require high accuracy velocity and acceleration data, providing and improving upon a system meeting those requirements has been of major concern to the Test Track for many years. Without a VMS of such high accuracy capability (approximately 1 part in 25,000) the missile guidance systems development programs on the Holloman Test Track beginning in the late 1950's would never have become a reality.

6.1 Test Procedure: In June 1974 a series of track tests was planned to evaluate the on-board magnetic VMS and make comparisons with the standard optical (light beam) VMS. It was planned to test the system at velocities ranging from 1,000 to 3,000 ft/sec and possibly to 4,000 ft/sec. The overall purpose was to develop a system that would overcome the deficiencies of the optical system as outlined in paragraph 1.3.2 and one that would provide an accuracy at least equal to that of the optical VMS.

A sled-borne head unit was designed and fabricated to accommodate three magnetic sensors with provisions for adjusting the sensor-magnet spacing. This head in conjunction with a dual optical space-time head was mounted on the sled to collect the required test data. Information of interest for analysis and comparison were: (1) sensor output waveform (input to voltage comparator circuit), (2) output of the voltage comparator, and (3) output of each optical system.

The magnetic sensor head unit was mounted immediately behind the optical head. The No. 1 magnetic sensor was 12.5 inches from the No. 1 (primary) optical beam. The three magnetic sensors were separated by 1.5 inches, and the No. 2 light beam was 2 inches behind the primary

beam. Magnet strips, $13/32$ " wide by 2" long of a selected and consistent polarity, were cemented to the light interrupter blades at precisely controlled positions.

A monorail sled, designated IMS 6833/SMS 6705, was used for all tests conducted at velocities up to 3,000 ft/sec.

6.2 Sensor Selection: Many of the same sensors that were tested in Phase I for the track-side application were also tested for use in the on-board system. Types 85001, 85002, 58404 and 58388 were tested for both applications. The latter two were found to be much too sensitive and they were also much larger than desired for on-board use. Provisions were made to test up to three systems on each sled run. In this way several combinations of sensors, electronic packages, and sensor to magnet spacing could be tested on a single sled run. As a result of extensive testing, the Electro type 4944C sensor was selected. It is small in size with adequate sensitivity at a reasonable spacing. However, this sensor must be modified for most applications. In its original configuration the sensor is $1\ 1/4$ inches long and connects to a 10 foot length of RG 58 c/u coaxial cable. The $3/8$ inch diameter is satisfactory. The unit is modified by cutting it down to $1/2$ inch in length, removing the coax cable and replacing it with a small two-wire shielded cable, then adding from $1/16$ to $1/8$ inch potting to cover the soldered connections. Following final selection of the type 4944C sensor unit, the big 3-unit aluminum head was replaced with a smaller phenolic head. This head was designed to house two of the 4944C sensor units in vertical alignment, separated by $5/8$ " center to center. The sensor head-magnet relationship is shown in Figure 4. The optimum spacing was determined to be about 0.375 inches.

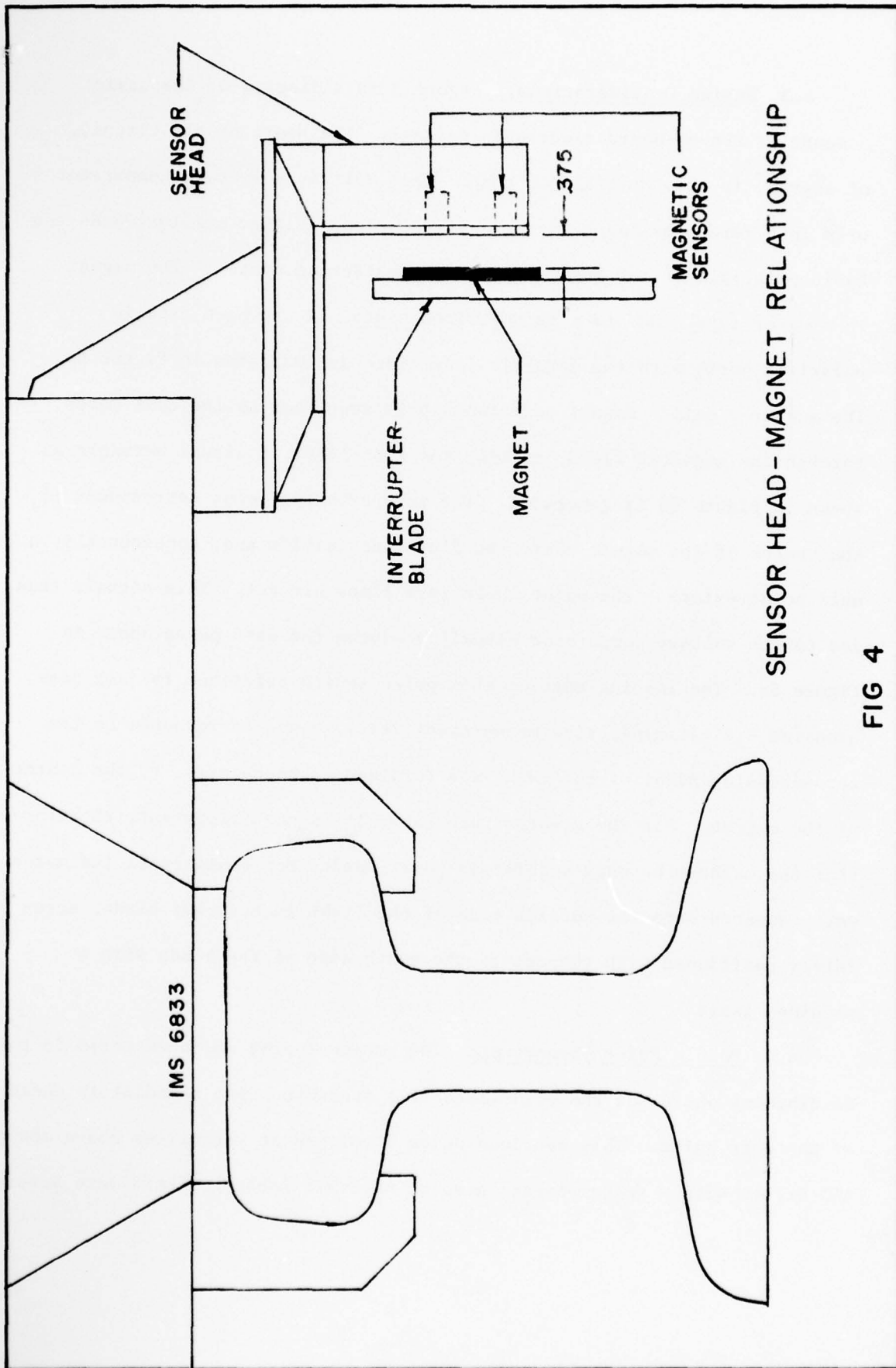
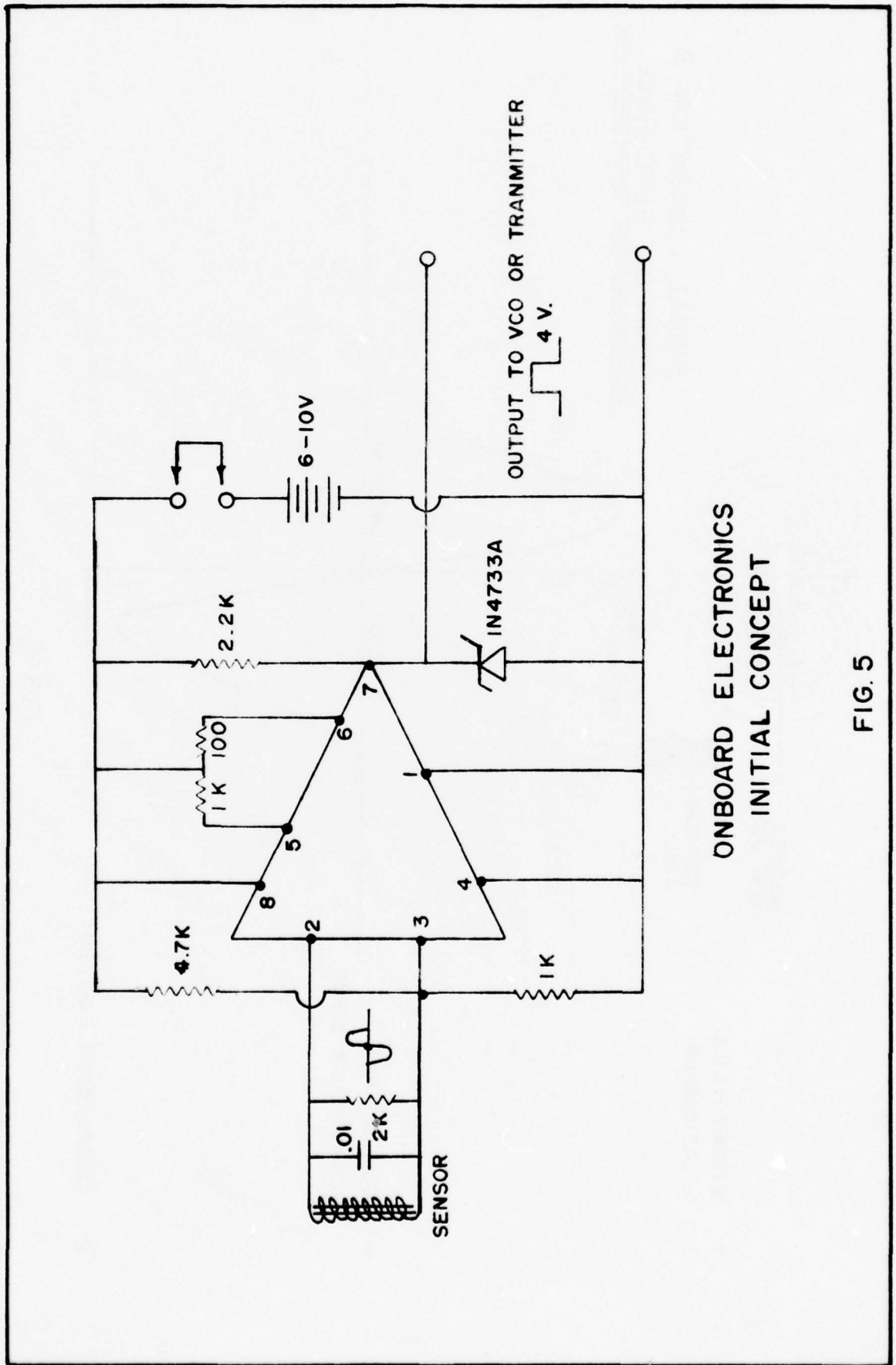

FIG 4

6.3 Design Considerations: Figure 5 is a diagram of the basic concept of the on-board electronic package. The heart of the circuit, of course, is the LM111/211 IC chip. This unit is a voltage comparator used in a zero-crossing detector configuration. Figure 6 illustrates the basic principle of the magnetic velocity measuring system. The magnet is a wafer type. One face is polarized south and the back face is polarized north with the magnetic flux lines as indicated in Figure 6a. The sensor coil - magnet relationship is such that as the coil moves through the magnetic field, cutting the flux lines, a signal waveform as shown in Figure 6b is generated. The zero-crossing point corresponds to the center of the magnet where the flux lines divide and, consequently, a null point exists - the point where zero lines are cut. This signal, then, fed to the voltage comparator circuit produces the data pulse shown in Figure 6c. The leading edge of this pulse is the reference for all data handling - digitizing, time measurement, etc., - and corresponds to the zero-crossing point of the input waveform and, consequently, to the center of the magnet. For the greatest accuracy, it is most important, therefore, that the magnets be very accurately positioned. For these tests the magnets were cemented onto the outside face of the light interrupter blade, accurately positioned with respect to the south edge of the blade with a machined gauge.

6.4 Double Pulse Phenomenon: The greatest problem encountered in this development phase was the occurrence of a spurious pulse immediately ahead of the data pulse. This spurious pulse developed at velocities above about 450 ft/sec with a sensor-magnet spacing of 0.375 inches. There were several



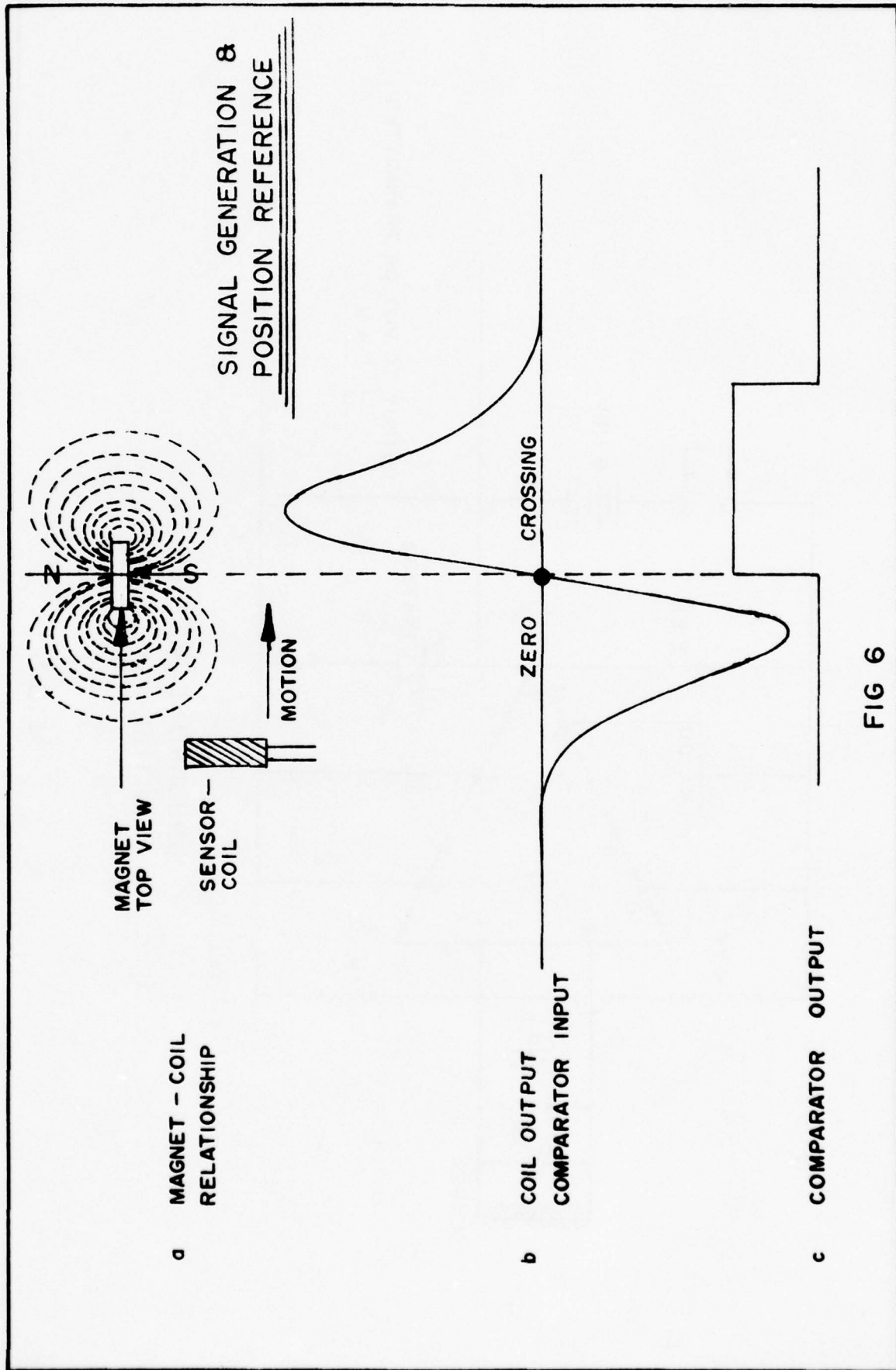

FIG 6

theories as to the cause of this double pulsing and numerous circuit modifications were made and tested in an attempt to correct the problem.

In the laboratory, test signals were generated by passing a magnet by a stationary sensor coil. This was accomplished with a 4-inch magnet strip attached to a motor shaft. With the AC motor available the maximum speed of the magnet by the sensor was about 40 ft/sec. At this speed a waveform similar to that shown in Figure 6b was generated. There was nothing peculiar about the waveforms thus generated that would indicate a characteristic capable of triggering a false pulse in the voltage comparator circuit. Later a small high speed DC motor was obtained and fixed with a magnet strip propeller. With this device higher magnet-sensor speeds could be attained and in conjunction with a spacing adjustment, a waveform such as shown in Figure 7 could be developed. At higher speeds the initial positive-going portion of the waveform reaches a magnitude of adequate level to trigger the comparator, thus producing the unwanted extra pulse.

6.5 Double Pulse Elimination: Once the cause of the spurious double pulse was definitely identified, a circuit modification could be designed to eliminate it from the data. Figure 8 shows the final electronic circuit which accomplishes this. The modification consists essentially of the addition of a logic one-shot multivibrator to the basic circuit shown in Figure 5. Figure 8A is a display of waveforms which illustrate the functions of this circuit and shows how the unwanted pulse (generated at point c and second of the pair in this case) is masked when it is developed in the comparator at higher velocities, and, therefore, gated out of the data channel.

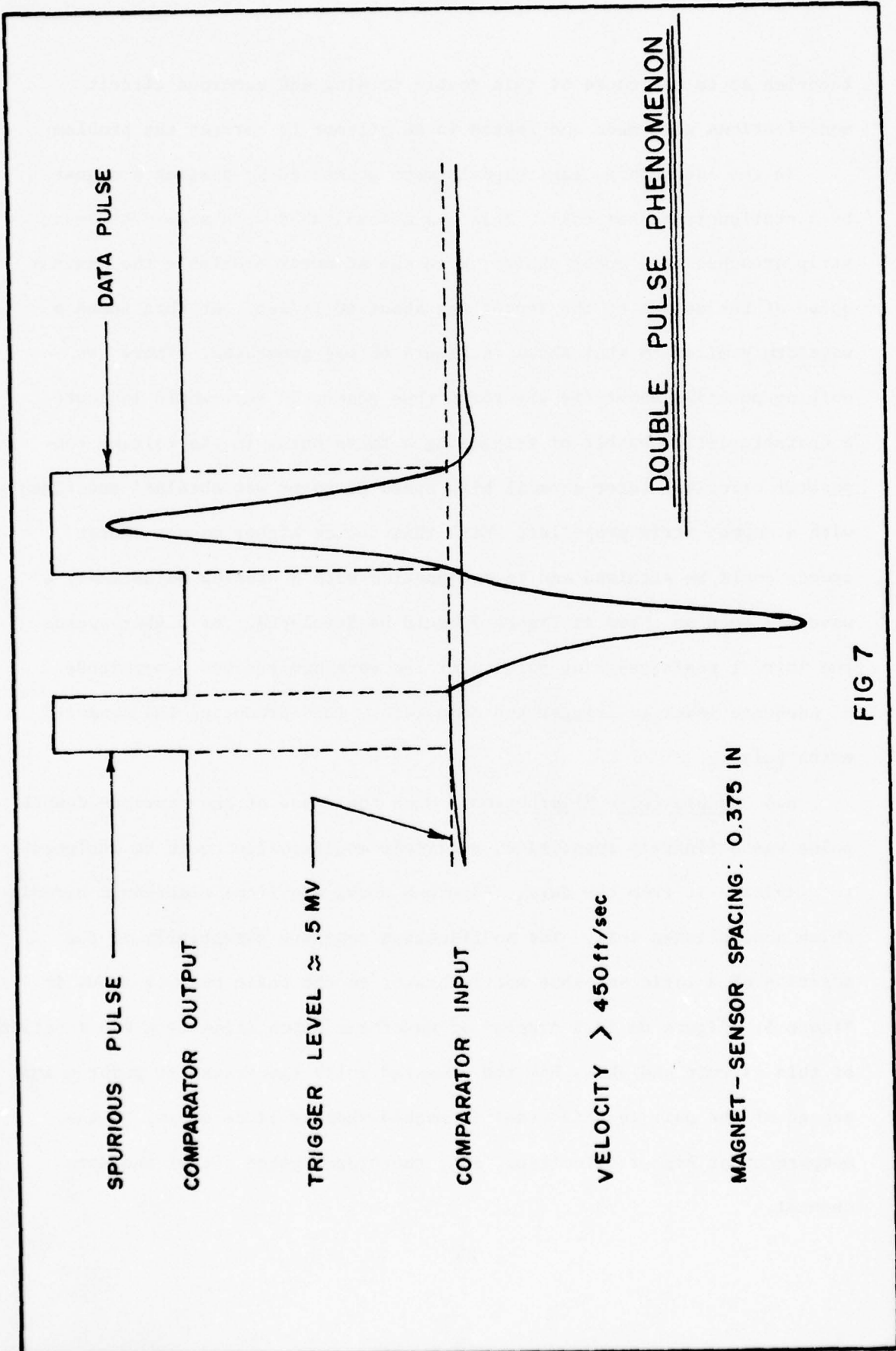
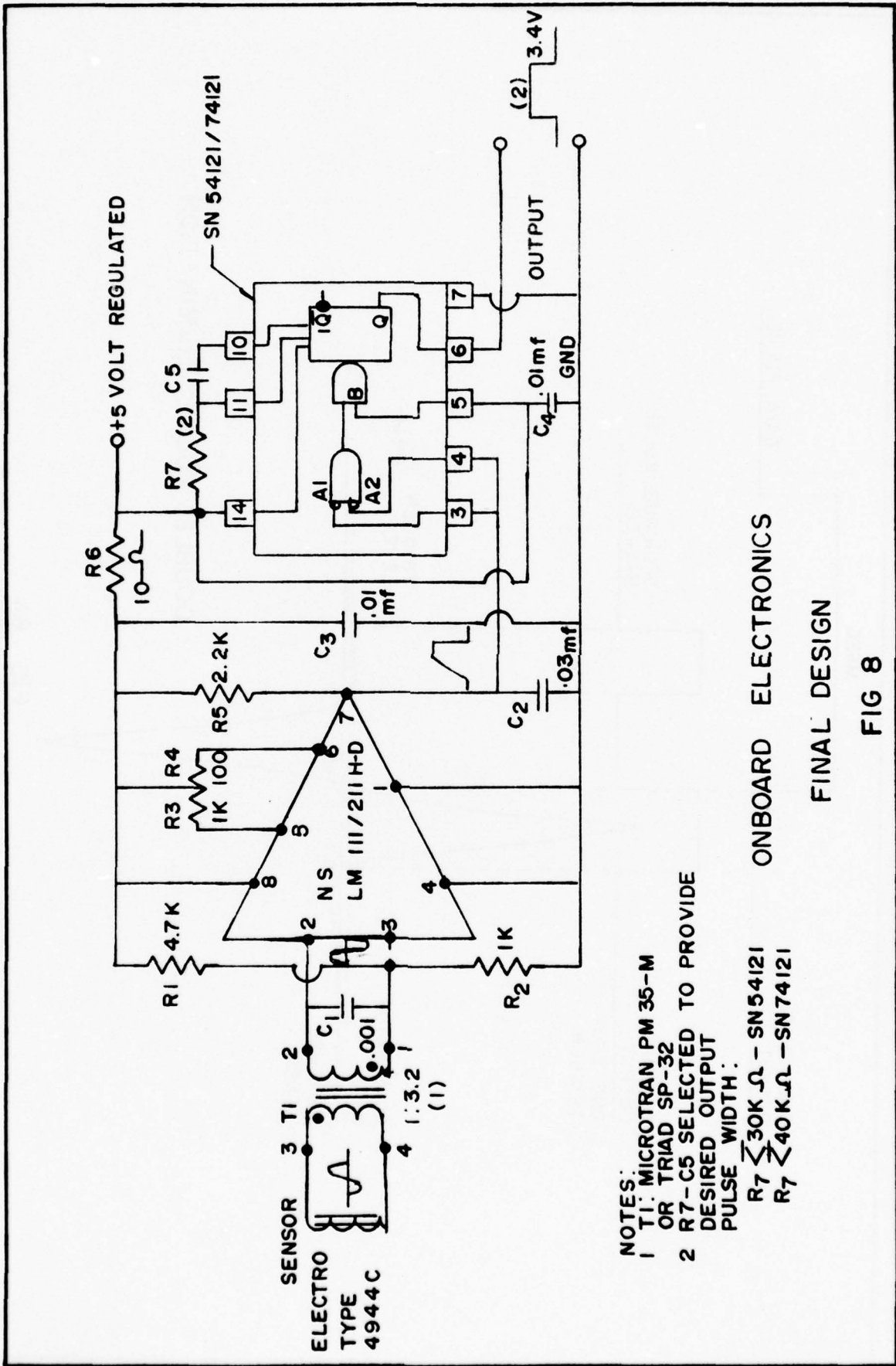

FIG 7



- NOTES:
- 1 TI: MICROTRAN PM 35-M OR TRIAD SP-32
 - 2 R7-C5 SELECTED TO PROVIDE DESIRED OUTPUT PULSE WIDTH:
 $R7 < 30K \Omega$ - SN54121
 $R7 < 40K \Omega$ - SN74121

ONBOARD ELECTRONICS
 FINAL DESIGN
 FIG 8

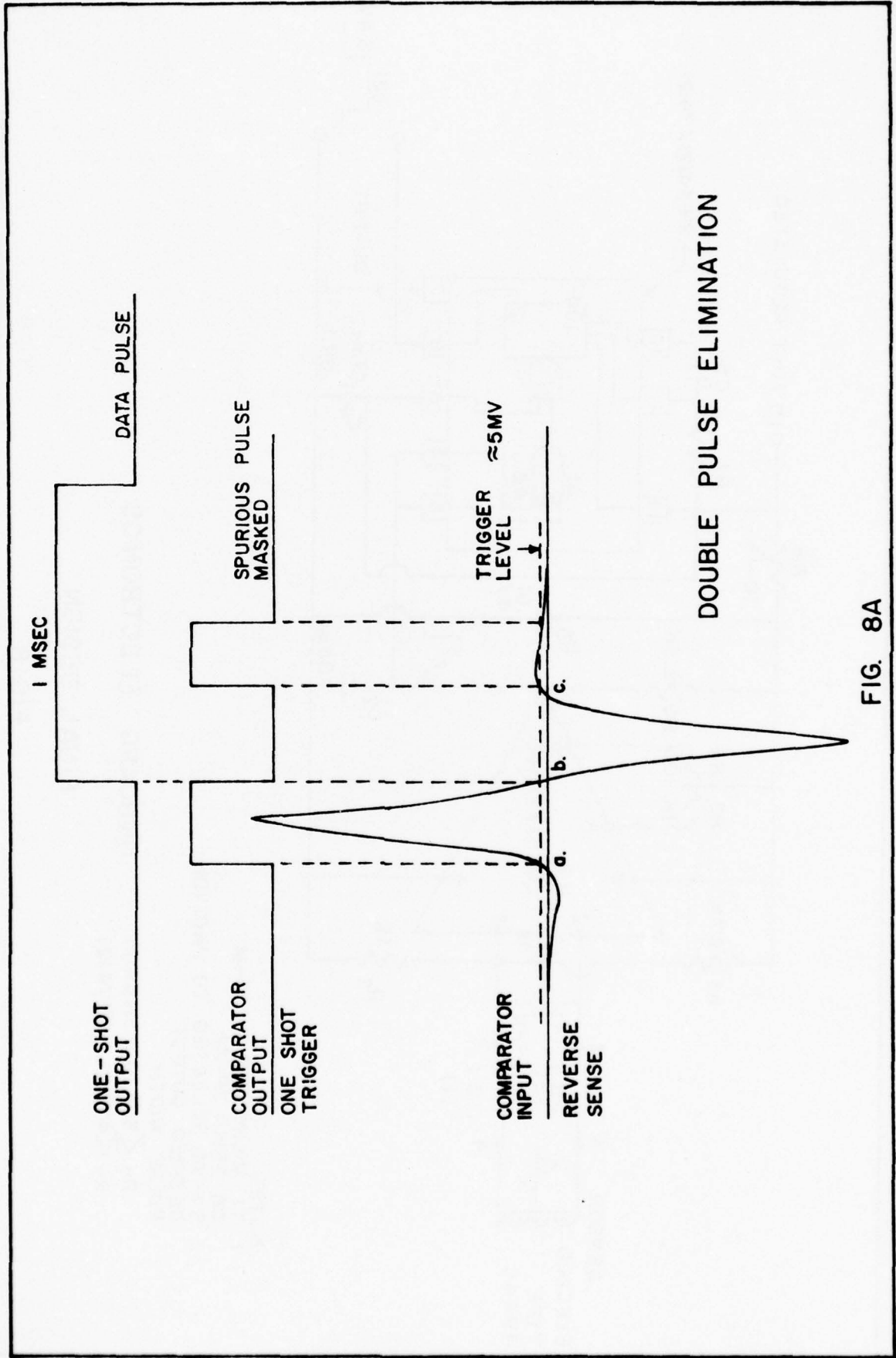

FIG. 8A

6.6 Circuit Theory: Referring again to Figures 8 and 8A the input waveform is reversed in phase through transformer T1. This sets the stage for eliminating the second (spurious) pulse. Now the initial portion of the waveform is negative-going and, of course, cannot trigger the comparator. But the comparator does trigger as the signal crosses zero at point a and proceeds in the positive direction. In this case the trailing edge of the comparator output pulse corresponds to point b on the waveform which, in turn, corresponds to the center of the trackside magnet. Since the trailing edge of the comparator output pulse triggers the one-shot, then the leading edge of the one-shot output pulse, which is the point of reference in data handling, also corresponds to the magnet centerline.

Transformer T1 is a Microtran type PM35-M or a Triad type SP-32. It is very small and rugged, molded in a solid epoxy case. Its size is 0.3 X 0.4 inch base by 0.47 inch high and weighs only 0.1 ounce. It has exceptional response up to 100,000 cps. T1, besides providing a phase reversal for the input waveform, can also provide a convenient signal gain of 3.2 through the step-up turns ratio. There will, however, be a few spurious pulses at velocities below 100 ft/sec. If improved accuracy were desired at the lower velocities, this could be accomplished by selecting T1 with a little higher gain factor (higher turns ratio). However, there would likely be additional spurious pulses that would have to be removed through data editing.

A gain of 10 was too great as it accounted for considerable double pulsing at lower sled velocities at the desired sensor-magnet spacing (no greater than 0.5 inches). In fact a 0.375 inch spacing is about nominal. There is an interlocking relationship between spacing, speed, and

gain, with each having an effect on accuracy and double pulsing. So there must be a certain amount of trade-off in order to realize the best balance possible. Since all the parameters mentioned above affect accuracy, it is imperative that great care and patience be exercised in placing the track-side magnets.

There was a certain amount of jitter in the leading edge of the comparator output pulse, resulting in random noise pulsing. Since this leading edge is not used for data referencing, it is integrated by C_2 in conjunction with R_5 to provide a pulse rise time of about 100μ sec. This eliminated the spurious triggering from that source. R_6C_3 is a decoupling network. The 5 volt regulated supply is obtained through a voltage regulator (National Semiconductor type LM309KC) normally mounted outside the VMS electronic package and the input connected to the sled 28 volt battery. The R_7C_5 combination is for setting the desired output pulse width which is defined by the following relationship:

$$t_p = R_7C_5 \ln 2$$

This circuit draws only 18.5 ma @ 5 volts, or 92.5 mw quiescent power dissipation. At 50% duty cycle, the dissipation is only about 120 mw. The circuit is assembled on a printed circuit board and housed in a box in a floating environment. The box used is 1 5/8" high X 2 9/16" wide X 4 1/4" long (5 1/4" long including a 1/2" mounting flange on each end). The circuit board is "floating" in that it is completely surrounded with a styrofoam, or similar, material and tightly pressed into the box. This packaging technique provides adequate ruggedness and protection to assure reliable operation through the most severe sled environments. In fact, two circuit boards have been packed into one box in the manner described, providing a

dual system in one package configuration. One circuit board could be packed into a box considerably smaller than the one described above if space became a factor in a particular program. The boxes used in this program were the Pomona Electronics Model 2901.

6.7 Metal Effect on Sensors: In paragraph 6.3 it was mentioned that the aluminum head was replaced with one fabricated from phenolic. It was found that the aluminum, although a nonferrous material, caused an attenuation of signals generated in the sensor coil when the sensor was inserted into the aluminum block. A simple device was fabricated to determine sensor output as a function of coil to metal spacing. Six holes were drilled in a block of aluminum varying in size from 3/8" diameter to 1" diameter. These holes provided a coil-metal uniform clearance of 1/16" to 3/8" in steps of 1/16". Figure 9 shows a plot of the information derived. The speed of the magnet (fan motor) and the magnet to coil spacing were held constant through each step of the test. The optimum output of the sensor, i.e., the output with no metal surrounding the sensor, was 180 millivolts as indicated by the horizontal line at the top of the chart. At the closest clearance (1/16") the signal loss was 56% and the loss decreases linearly as the clearance increases. The loss was 21% with 3/8" clearance. It is important, therefore, in order to realize optimum performance, that the sensor be housed in a nonmetallic material such as phenolic. When there are instances that the complete head structure cannot be fabricated from phenolic, the sensor should be inserted into a phenolic or teflon section of the head unit and be as far removed from the metal as structurally feasible.

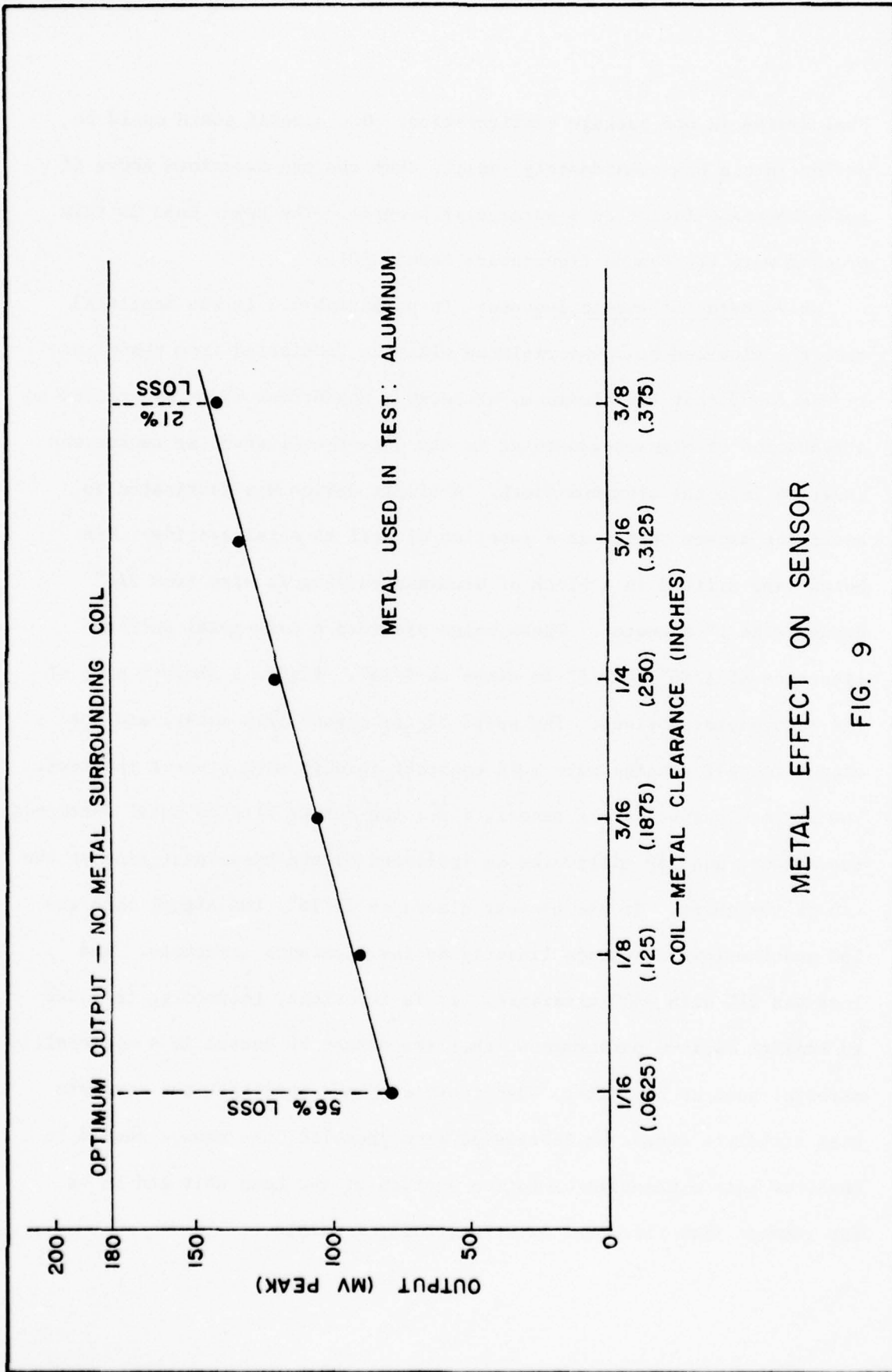

METAL EFFECT ON SENSOR

FIG. 9

6.8 Sensor Output vs Velocity: The relationship between sensor output and velocity is shown in Figure 10. For a fixed sensor to magnet spacing, the output will vary linearly with velocity. This linear relationship makes it convenient to predict sensor output during a sled run over the complete velocity range. This information assists in determining input circuit gain requirements to obtain data through the complete run and with the least possible displacement error as the sled velocity decreases. Laboratory tests show that with a peak input to the comparator of 60 mV there is no discernible displacement error in the one-shot output signal. Thus, with a gain factor of 3.2 available through the input transformer, a sensor output (transformer input) of about 19 mV is required. From Figure 10 it is determined that, at a spacing of 0.5 inch, a speed of 47.5 ft/sec will produce a sensor output of 19 mV, thus providing accurate velocity data down to 47.5 ft/sec. Below this speed the displacement error would come into play and increase with decreasing velocity. In this case there would be very few double pulses; whereas, if the gain were doubled, there would likely be a considerable number. This is a part of the trade-off situation discussed earlier.

6.9 System Comparison - Optical versus Magnetic: The Analysis Branch (GDAN) of the Guidance Test Division performed the data analysis. The procedure and summary of findings is the result of their efforts.

The VMS data was analyzed by digitizing both optical and magnetic pulses. Band pass and low pass filters were used to isolate the particular signal from the recorded complex and the General Input

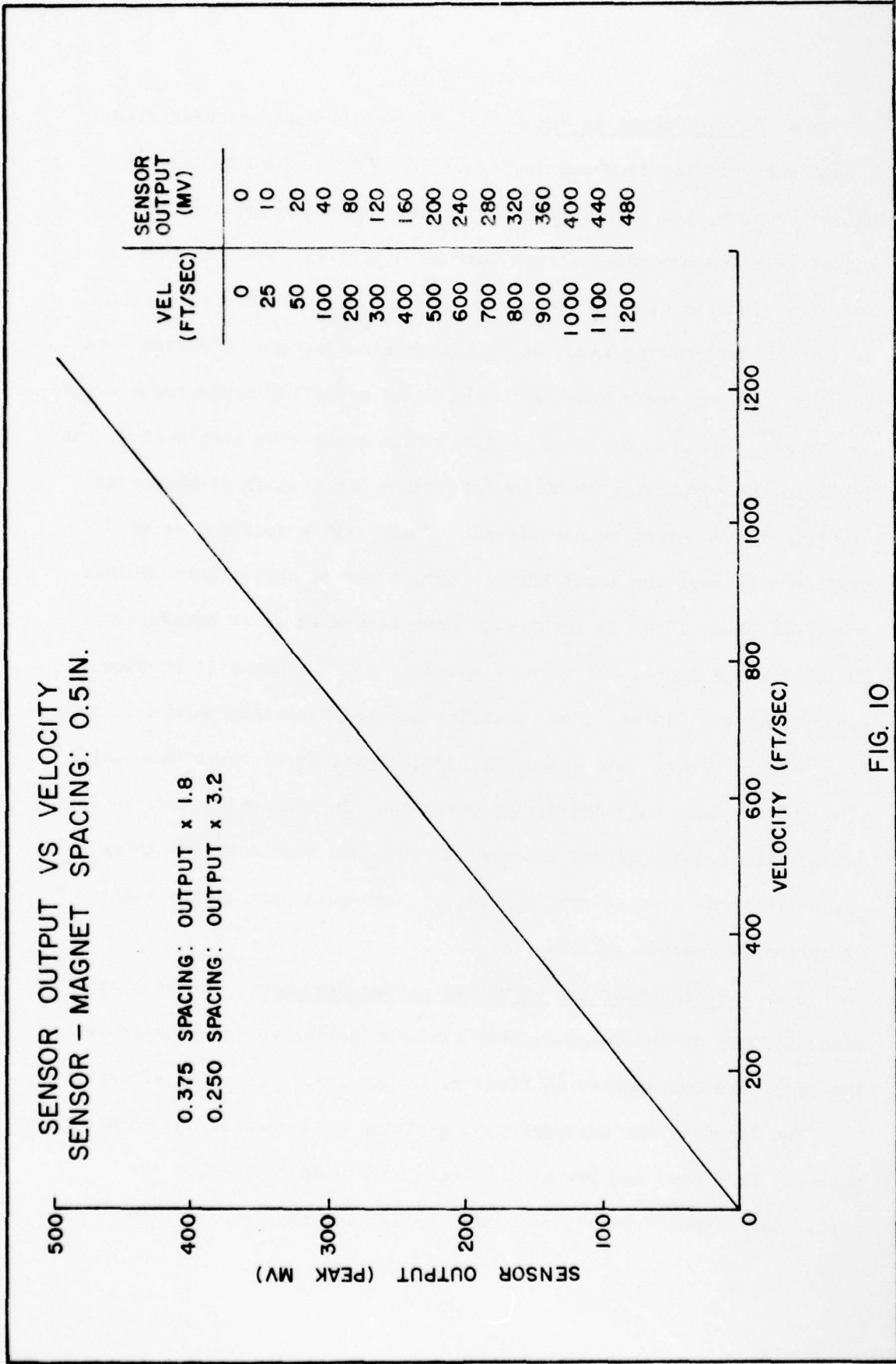

FIG. 10

Converter (GIC) was used to provide a series of times for the leading edges of the pulses. From a knowledge of the light interrupter and magnet locations along the track, time and distance series were constructed from the optical and magnetic sensors. Then, using the optical times as a reference, the magnetic data were interpolated to the optical times, giving a time and two distances associated with that time. The optical distance was subtracted from the magnetic distance to form a distance comparison, ΔS , optical versus magnetic, throughout the run. Using an average derivative program with a 0.25 second sliding time interval, the ΔS function was differentiated to form a comparison in the velocity domain, ΔV .

Usually, on a sled test there were two optical sensors and two magnetic sensors which produced usable data to analyze. The two distance series derived from the magnetic sensors were designated S_{m1} and S_{m2} . Similarly, the two distance series derived from the optical sensors were designated S_{o1} and S_{o2} . Comparisons were made between both optical series and both magnetic series in addition to comparisons of optical with optical and magnetic with magnetic.

For the results that follow, five distance comparison functions were chosen:

$$\Delta S_1 = S_{o2} - S_{o1}$$

$$\Delta S_2 = S_{m1} - S_{o1}$$

$$\Delta S_3 = S_{m1} - S_{o2}$$

$$\Delta S_4 = S_{m2} - S_{o1}$$

$$\Delta S_5 = S_{m2} - S_{m1}$$

There were noticeable trends in the above functions which correlated with velocity (V) and inverse velocity (1/V). A constant bias due to the physical separation of the sensors on the sled was also noticeable. The velocity trend is most likely due to time lags in either the separate instrumentation channels for each sensor or in the sensor circuitry itself. The inverse velocity trend is a phenomenon related to the magnetic sensor only and is the result of the fact that the magnetic sensor generates an output pulse based on a certain threshold voltage detected from the input induced magnetic waveform. At low velocity this threshold point tends to drift away from the input waveform zero crossing point and, consequently, from the magnet centerline due to a lower induced voltage.

The magnitudes of the trends and of the constant bias term were estimated by using a least squares linear estimation routine. The trends and constant bias term were then subtracted from the comparison functions yielding five zero-mean residual functions. Root mean square (RMS) values for each residual function were then calculated.

The RMS values were used to estimate the one sigma accuracy estimates associated with each of the four sensors. These four one sigma accuracy estimates are designated σ_{o1} , σ_{o2} , σ_{m1} , and σ_{m2} . In addition, a term was introduced to account for random variations between the magnetic trigger point and the optical trigger point. This term is designated σ_{m-o} and is involved only when comparing a magnetic distance to an optical distance.

The one sigma accuracy estimates were obtained from the simultaneous solution of the following five equations:

$$\begin{aligned}(\sigma_{o1})^2 + (\sigma_{o2})^2 &= \text{RMS}_1^2 \\(\sigma_{m1})^2 + (\sigma_{o1})^2 + (\sigma_{m-o})^2 &= \text{RMS}_2^2 \\(\sigma_{m1})^2 + (\sigma_{o2})^2 + (\sigma_{m-o})^2 &= \text{RMS}_3^2 \\(\sigma_{m2})^2 + (\sigma_{o1})^2 + (\sigma_{m-o})^2 &= \text{RMS}_4^2 \\(\sigma_{m1})^2 + (\sigma_{m2})^2 &= \text{RMS}_5^2\end{aligned}$$

where the five RMS values are the root mean square values calculated from the residual functions.

The sled run was divided into three velocity regimes and the one sigma accuracy estimates were calculated for each regime.

An identical process was used for the estimation of one sigma velocity accuracies. The following is a tabulation of the results from one sled run for both position and velocity.

Sigma Estimate	High Velocity (0-1050 - 640 fps)		Med Velocity (640 - 320 fps)		Low Velocity (320 - 75 fps)	
	Position (ft)	Velocity (fps)	Position (ft)	Velocity (fps)	Position (ft)	Velocity (fps)
σ_{o1}	.00235	.01557	.00145	.00812	.00038	.00205
σ_{o2}	.00410	.02011	.00188	.00883	.00084	.00441
σ_{m1}	.00125	.00778	.00094	.00539	.00075	.00379
σ_{m2}	.00164	.00914	.00090	.00500	.00068	.00272
σ_{m-o}	.00243	.01120	.00193	.00866	.00155	.00778

The above results must be interpreted carefully to prevent erroneous conclusions. The "one sigma" accuracy estimate of either magnetic sensor must include the σ_{m-o} estimate since this represents the random variation

between the magnetic trigger point and the optical trigger point. Methods exist to measure the location of the optical trigger point (via laser interferometer survey); however, no method exists presently to measure precisely the trigger point of the magnetic system.

By forming the root sum square of the σ_{m-o} with σ_{m1} and σ_{m2} as follows one can tabulate realistic accuracies associated with the magnetic system:

$$(\sigma_{m1}') = \sqrt{(\sigma_{m-o})^2 + (\sigma_{m1})^2}$$

$$(\sigma_{m2}') = \sqrt{(\sigma_{m-o})^2 + (\sigma_{m2})^2}$$

Sigma Estimate	High Velocity (0-1050 - 640 fps)		Med Velocity (640 - 320 fps)		Low Velocity (320 - 75 fps)	
	Position (ft)	Velocity (fps)	Position (ft)	Velocity (fps)	Position (ft)	Velocity (fps)
σ_{o1}	.00235	.01557	.00145	.00812	.00038	.00205
σ_{o2}	.00410	.02011	.00188	.00883	.00084	.00441
σ_{m1}'	.00273	.01364	.00215	.01020	.00172	.00865
σ_{m2}'	.00293	.01446	.00213	.01000	.00169	.00824

From the above table it is apparent that through the acceleration, peak velocity and down to 640 ft/sec (first 500 interrupters) the one sigma accuracy of the magnetic system looks highly promising. Through medium velocity (640 - 320 ft/sec) the two systems are comparable with the optical slightly more accurate. In the lower velocity regime (320 - 75 ft/sec) the one sigma accuracy spread increases

further in favor of the optical system. However, circuit modifications made since the above run data were obtained should considerably improve the lower velocity accuracy (reference paragraph 6.8, page 33).

Earlier in this report the importance of accurate placement of magnets was pointed out. Figure 11 is a sketch of a device designed for accurately placing the magnets on the rail web with respect to the interrupter blade. So, whatever distance measurements are applied to the interrupter blades for the optical VMS, the same can be applied to the magnets for magnetic VMS. In the case of any future system comparison, data correlation should be much simpler.

6.10 Rail-Web Magnets: In the track extension from station 35,500 to 50,700 the addition of the narrow gauge track makes it impossible to extend the existing interrupter system along the east (center) rail. Therefore, it was imperative to devise another method for magnetic detection. The idea was conceived of placing the magnets in the web of the rail in such a position that they would be safe from damage by passing sled slippers but still capable of properly energizing a sled-borne sensor coil. For this purpose it was necessary to design an appropriate sled-mounted sensor bracket that would clear all track tie-down hardware but still maintain the proper proximity relationship with respect to the magnets. Figure 12 shows a sketch of such bracket and the related sled-rail-magnet geometry.

Several sled runs were made to check the feasibility of the rail-web magnetic approach. It was necessary to learn the effect of the rail on the waveform produced by the magnet and its effect on the signal

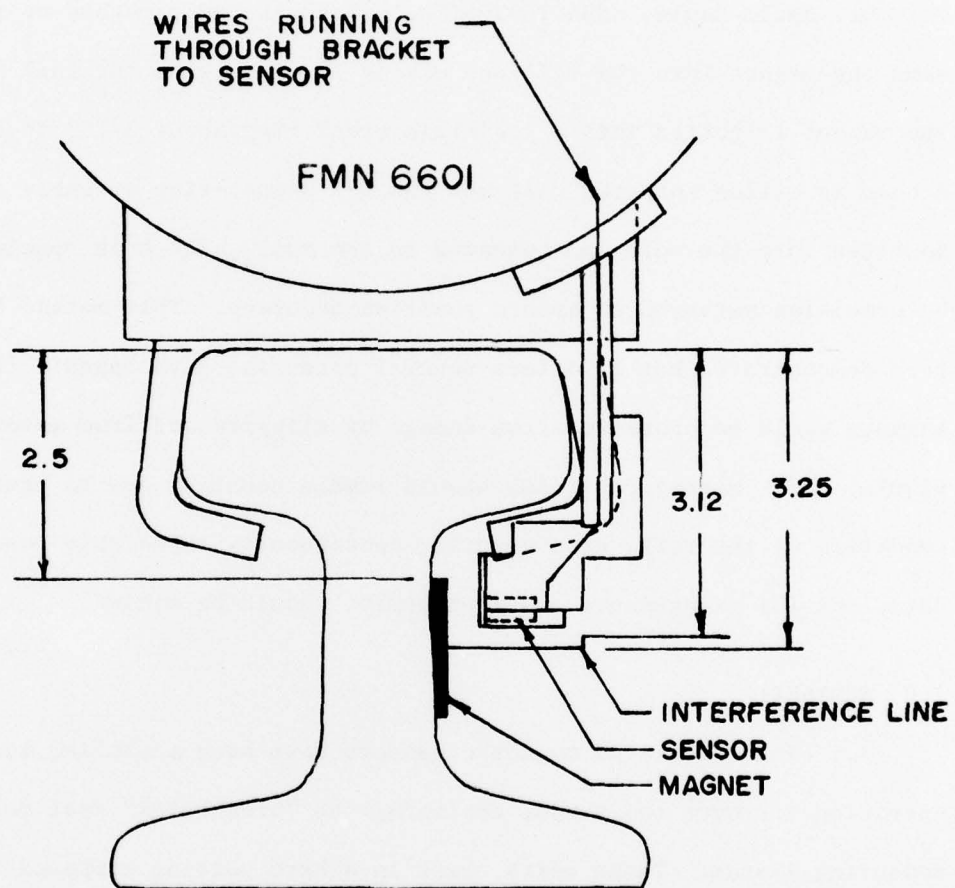

RAIL-WEB MAGNETIC SYSTEM

FIG 12

strength. The results were positive on both counts - the waveform was not noticeably affected and the signal strength actually increased by a factor of about three over that obtained from the interrupter-mounted magnets at equal spacing. Tests have been conducted at velocities up to about 4,000 ft/sec and accelerations up to about 31 g's.

Mr. Berle Engle, 6585 TESTG/TKO, has suggested a method of recessing the magnet into the rail web making it flush with the rail surface. The magnet is potted into a stainless steel ring about 3/16" in depth. A hole is milled into the rail web and the magnet-ring assembly is inserted into the hole and cemented to the rail. The hole spacing would be precision surveyed to assure position accuracy. This method has not been demonstrated but it offers several potential advantages: (1) the magnets would be protected from damage by slippers and from motor blasts; (2) magnet positions should remain constant due to prestressed condition of the rail, thus assuring continuously repeatable position data; and (3) maintenance and replacement should be minimal.

7.0 SUMMARY:

7.1 The track-side magnetic sensors have been installed and operating for over two years, replacing the "breakstick" spot velocity measuring system. These units, cast in a hard potting compound (Hysol C9-4183), are impervious to foreign matter and operate reliably through year-around weather conditions, congealed water braking, and the rainfield.

7.2 The magnetic sensor is a no-contact, proximity type sensor responding to the passing of a sled slipper. The unit is disabled for about one minute after being triggered by the first slipper, so it cannot be multi-triggered by subsequent slippers.

7.3 Numerous units may be operated in parallel without interference or interaction between units.

7.4 The on-board magnetic system has operated through a peak velocity of 3,684 ft/sec and a peak acceleration of 114 g's, producing near perfect data - only one spurious pulse. (Ref 46G-B2 Run, 6 Aug 1976.)

7.5 It has been shown that magnets attached to rail web are operationally feasible to 4,000 ft/sec and provide an average of 3:1 increase in sensor signal strength.

7.6 It is shown by the analysis of data obtained from a typical sled run that the accuracy of the magnetic system is comparable to the optical from 0-1050-320 fps. At the lower coast-out velocities (320 - 75 fps) the optical system is slightly more accurate.

8.0 RECOMMENDATIONS:

8.1 Track-side sensors to be used in locations where there are no breakstick brackets available for mounting should be cemented to a 1/2 inch thick strip of silicone rubber and then cemented to the web of the rail, being careful to maintain the 3 1/4 inch vertical clearance below the top of the rail. If sensors and spacers are temporarily installed for a particular mission, they may be taped to the rail.

8.2 In operating two or more on-board systems simultaneously, it was found that usually the data from one channel was distinctively better than from other channels. This was true with both the magnetic and optical systems. In view of this observation, it is recommended that, whenever possible, two separate channels or systems be operated on a mission, whether the system be magnetic or optical. This would double

the chances of obtaining good velocity data and could save having to rerun many expensive missions. Running a dual magnetic system would be extremely simple and would require very little additional space.

8.3 In regard to future development, it is recommended that consideration be given to digitizing and recording VMS data on-board the sled in real time. Computer (microprocessor) and memory (magnetic bubbles) technology have advanced to the point that this would seem feasible.

Magnetic bubble memories which have been in the process of development over the past several years will soon be entering the marketplace. A 100-kilobit bubble-memory chip, 345 by 365 mil in area, is now being sampled by Texas Instruments and should be in production by the middle of 1977. The chip will be packaged in a 14-pin, 1-inch wide, dual-inline configuration.

It is possible that, not only VMS data, but all instrumentation data could be handled this way. This could result in more accurate measurements since it would eliminate inherent errors in instrumentation and propagation.

List of References

1. Bushnell, Dr. David, Origin and Operation of the First Holloman Track; Vol I, History of Tracks and Track Testing at the Air Force Missile Development Center, Holloman AFB, N.M., 1949-1956.
2. Armour Research Foundation, Velocity Measuring Study, Final Report, Contract No. AF 29(600)-1022, AFR Project No. E 075, November 1956.
3. Southwest Research Institute, A Velocity Measurement Study, Final Report, Contract No. AF 29(600)-1023, 23 November 1956.
4. Midwest Research Institute, A Velocity Measurement Study, Final Report, Contract No. AF 29(600)-1024, M.R.I. Project No. 860-E-108, 23 November 1956.
5. Air Force Special Weapons Center, 6585th Test Group, Test Track Division, The Holloman Track Facilities and Capabilities, 1974, pg 38.
6. Electro Products Laboratories, Inc., (now Electro Corporation, Sarasota, FL), Magnetic Pickup Handbook, No. 52.065B, Rev. 3-1-65.
7. MAI Corporation, Study of Laser Application to Velocity Measuring System, Technical Summary Reports covering the following:
 - Phase I - Report No. ER-3156, July 1963
 - Phase II - Report No. ER-3570, July 1964
 - Phase V - Report No. ER-4131, September 1965
 - Phases VII and VIII - Report No. ER-4136, September 1965
 - Phase IX - Report No. ER-4889, April 1967Clark, Mr. H. G. and Pearson, Capt Donald J., Laser VMS, Memo for Record, 13 August 1969.

DISTRIBUTION LIST

<u>Organization</u>	<u>Number Copies</u>
DDC/TIAAS Cameron Station Alexandria, VA 22314	12
ADTC/DLOSL Eglin AFB, FL 32542	1
ADTC/TE Eglin AFB, FL 32542	1
3201ABG/HO Eglin AFB, FL 32542	1
6585 Test Group <u>Holloman AFB, NM 88330</u>	
TSL	1
CC	1
GD	1
TK	1
TK (Mr. Rasmussen)	1
TKI	1
TKE	10
TKS	1
TKO	5

UNCLASSIFIED

SECURITY CLASSIFICATION OF THIS PAGE (When Data Entered)

19 REPORT DOCUMENTATION PAGE		READ INSTRUCTIONS BEFORE COMPLETING FORM
1. REPORT NUMBER ADTC-TR-77-6	2. GOVT ACCESSION NO.	3. RECIPIENT'S CATALOG NUMBER
4. TITLE (and Subtitle) Development of Advanced Sled Velocity Measuring Techniques Covering Trackside Magnetic VMS and On-Board Magnetic VMS,		5. TYPE OF REPORT & PERIOD COVERED Final rept.
7. AUTHOR(s) E. Wayne/Melton		6. PERFORMING ORG. REPORT NUMBER
9. PERFORMING ORGANIZATION NAME AND ADDRESS Test Track Division (TK) 6585th Test Group (AFSC) Holloman AFB, New Mexico 88330		8. CONTRACT OR GRANT NUMBER(s)
11. CONTROLLING OFFICE NAME AND ADDRESS 6585th Test Group (AFSC) Holloman AFB, New Mexico 88330		10. PROGRAM ELEMENT, PROJECT, TASK AREA & WORK UNIT NUMBERS JON: 9950S005
14. MONITORING AGENCY NAME & ADDRESS (if different from Controlling Office) Same as 11.		12. REPORT DATE 20 January 1977
		13. NUMBER OF PAGES 45 (253p)
		15. SECURITY CLASS. (of this report) Unclassified
		15a. DECLASSIFICATION/DOWNGRADING SCHEDULE NA
16. DISTRIBUTION STATEMENT (of this Report) Approved for public release; distribution unlimited.		
17. DISTRIBUTION STATEMENT (of the abstract entered in Block 20, if different from Report) Same as 16		
18. SUPPLEMENTARY NOTES		
19. KEY WORDS (Continue on reverse side if necessary and identify by block number)		
20. ABSTRACT (Continue on reverse side if necessary and identify by block number) The Test Track facility at Holloman AFB, New Mexico, operates rocket sleds for developmental test purposes at speeds into the high supersonic regime. A fundamental requirement on practically all track missions is a knowledge of velocity as a function of time and position. This report presents some historical background and discusses the evolution of two basic velocity measuring systems. The distinct purpose and function of each system as well as the need for upgrading the two systems is shown. The development of two magnetic		

389490

Smca

UNCLASSIFIED

SECURITY CLASSIFICATION OF THIS PAGE(When Data Entered)

systems fulfilling present day requirements is described and discussed in detail. A thorough treatment of data analysis is given and a comparison of the magnetic on-board system with respect to the standard optical system is shown.