

AD-A042 744

COAST GUARD RESEARCH AND DEVELOPMENT CENTER GROTON CONN F/G 13/2
THE U.S. COAST GUARD OILY WATER SEPARATOR TESTING LABORATORY.(U)
MAR 77 R E WILLIAMS

UNCLASSIFIED

CGR/DC-10/77

USCG-D-33-77

NL

| OF |

ADA042 744



END
DATE
FILMED
9 - 77
DDC

REPORT NO. CG-D-33-77
TASK No. 774305.2

14
B.S.

ADA 042744

THE U. S. COAST GUARD OILY WATER
SEPARATOR TESTING LABORATORY

R. E. Williams
U. S. Coast Guard Research and Development Center
Avery Point, Groton, Connecticut 06340



March 1977

Final Report

DDC
APR 11 1977
C

Document is available to the U. S. public through the
National Technical Information Service,
Springfield, Virginia 22161

AD No. _____
DDC FILE COPY.

PREPARED FOR
U.S. DEPARTMENT OF TRANSPORTATION
UNITED STATES COAST GUARD
OFFICE OF RESEARCH AND DEVELOPMENT
WASHINGTON, D.C. 20590

NOTICE

This document is disseminated under the sponsorship of the Department of Transportation in the interest of information exchange. The United States Government assumes no liability for its contents or use thereof.

The United States Government does not endorse products or manufacturers. Trade or manufacturers' names appear herein solely because they are considered essential to the object of this report.

The contents of this report reflect the views of the Coast Guard Research and Development Center, which is responsible for the facts and accuracy of data presented. This report does not constitute a standard, specification or regulation.

D. L. Birkimer

DONALD L. BIRKIMER, Ph.D., P.E.
Technical Director
U.S. Coast Guard Research and Development Center
Avery Point, Groton, Connecticut 06340

Technical Report Documentation Page

1. Report No. (18) US CG-D-33-77 ✓	2. Government Accession No.	3. Recipient's Catalog No.	
4. Title and Subtitle (6) THE U.S. COAST GUARD OILY WATER SEPARATOR TESTING LABORATORY		5. Report Date (11) March 1977	6. Performing Organization Code
7. Author(s) (10) R. E. WILLIAMS	8. Performing Organization Report No. (14) CGR/DC-10/77		10. Work Unit No. (TRAIS) 774305.2
9. Performing Organization Name and Address U. S. Coast Guard Research and Development Center ✓ Avery Point Groton, CT 06340		11. Contract or Grant No.	
12. Sponsoring Agency Name and Address Department of Transportation U. S. Coast Guard Office of Research and Development Washington, D.C. 20590		13. Type of Report and Period Covered (9) Final Report	14. Sponsoring Agency Code
15. Supplementary Notes			
16. Abstract This report describes the U. S. Coast Guard's Oily Water Separator Testing Laboratory installed on board the former cargo vessel SS MAYO LYKES located at the U. S. Coast Guard Fire and Safety Test Facility test site, Little Sand Island, Mobile, Alabama. (12) 59p.			
17. Key Words Oil Pollution Control Oily water separator testing		18. Distribution Statement Document is available to the public through the National Technical Information Service, Springfield, Virginia 22161	
19. Security Classif. (of this report) Unclassified	20. Security Classif. (of this page) Unclassified	21. No. of Pages 60	22. Price

DDC
 REPRODUCED
 AUG 11 1977
 NIST/STL
 C

METRIC CONVERSION FACTORS

Approximate Conversions to Metric Measures			Approximate Conversions from Metric Measures					
Symbol	When You Know	Multiply by	To Find	Symbol	When You Know	Multiply by	To Find	Symbol
LENGTH								
in	inches	2.5	centimeters	cm	millimeters	0.04	inches	in
ft	feet	30	centimeters	cm	inches	0.4	inches	in
yd	yards	0.9	meters	m	feet	3.3	feet	ft
mi	miles	1.6	kilometers	km	meters	1.1	yards	yd
					kilometers	0.6	miles	mi
AREA								
in ²	square inches	6.5	square centimeters	cm ²	square centimeters	0.16	square inches	in ²
ft ²	square feet	0.09	square meters	m ²	square meters	1.2	square yards	yd ²
yd ²	square yards	0.8	square meters	m ²	square kilometers	0.4	square miles	mi ²
mi ²	square miles	2.6	square kilometers	km ²	hectares (10,000 m ²)	2.5	acres	ac
	acres	0.4	hectares	ha				
MASS (weight)								
oz	ounces	28	grams	g	grams	0.035	ounces	oz
lb	pounds	0.45	kilograms	kg	kilograms	2.2	pounds	lb
	short tons (2000 lb)	0.9	tonnes	t	tonnes (1000 kg)	1.1	short tons	st
VOLUME								
tsp	teaspoons	5	milliliters	ml	milliliters	0.03	fluid ounces	fl oz
Tbsp	tablespoons	15	milliliters	ml	liters	2.1	pints	pt
fl oz	fluid ounces	30	milliliters	ml	liters	1.06	quarts	qt
c	cups	0.24	liters	l	liters	0.26	gallons	gal
pt	pints	0.47	liters	l	cubic meters	35	cubic feet	ft ³
qt	quarts	0.95	liters	l	cubic meters	1.3	cubic yards	yd ³
gal	gallons	3.8	liters	l				
ft ³	cubic feet	0.03	cubic meters	m ³				
yd ³	cubic yards	0.76	cubic meters	m ³				
TEMPERATURE (exact)								
°F	Fahrenheit temperature	5/9 (after subtracting 32)	Celsius temperature	°C	°C	9/5 (then add 32)	Fahrenheit temperature	°F

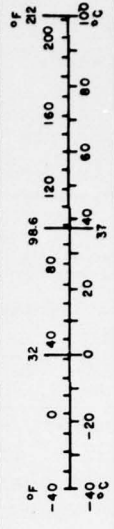
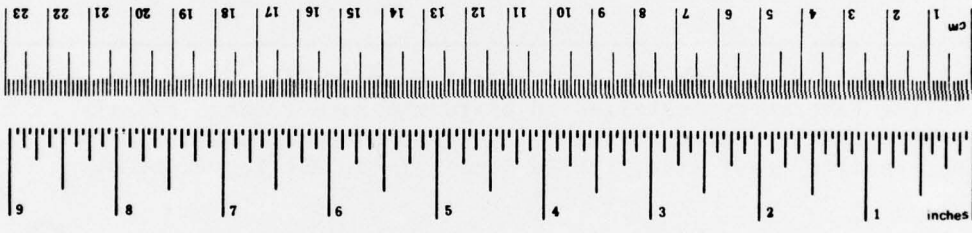

*1 in = 2.54 exactly. For other exact conversions and more detailed tables, see NBS Misc. Publ. 286, Units of Weights and Measures, Price \$2.25, SD Catalog No. C13.10.286.

TABLE OF CONTENTS

	<u>Page</u>
1.0 INTRODUCTION	1
2.0 SYSTEM DESCRIPTION	1
APPENDIX A - IMCO Specifications	A-1

LIST OF FIGURES

<u>Figure</u>		<u>Page</u>
1	Separator Test Loop	4
2	Diagrammatic Plan of Oil Blending System	6
3	Photos of Installation	
3-1	Separator on Inclining Platform	7
3-2	Test Oil Storage Tanks	8
3-3	Test Oil Injection Pump	9
3-4	Influent Pump and Modulating Control	10
3-5	Effluent Cleanup System	11
3-6	Instrumentation Panel	12
3-7	In-Line Monitor Display	13
3-8	Particulate Mixing Tank	14
3-9	Auxiliary Equipment	15
3-10	Grab Sample IR Analysis Equipment	16
3-11	Filter Type Separator on Test Platform	17
3-12	Combination Plate Separator and Coalescer System on Test Platform	18
3-13	Three-Stage Coalescer Type Separator on Test Platform	19
3-14	Heavy Mixing Oil Stock Resupply	20
3-15	Oil Blending Pump	21
3-16	No. 2 Test Oil and Test Water Resupply	22

ACCESSION for	
NTIS	<input checked="" type="checkbox"/>
DDC	<input type="checkbox"/> Buff
UNANNOUNCED	
JUSTIFICATION	
BY	
DISTRIBUTION/AVAILABILITY	
Dist.	Avail. and
A	

LIST OF TABLES

<u>Table</u>		<u>Page</u>
1	List of Equipment	5

1.0 INTRODUCTION

In 1975 the Coast Guard Research and Development Center was requested by Coast Guard Headquarters Office of Research and Development to install an oily/water separator testing laboratory and to conduct tests of oily/water separators to validate the then proposed IMCO (Inter-Governmental Maritime Consultative Organization) specification for such equipment. Appendix A is the current specification.

The R&D Center satisfied this request by installing an oily/water separator test loop in the No. 4 hold of its test ship, SS MAYO LYKES, a Victory Type Cargo Vessel, located at Little Sand Island, Mobile, Alabama. The test loop, Figure 1, was designed to utilize the ship's deep, double bottom and potable water tanks for influent test water, effluent discharge and oil slop storage.

Test oil storage was provided by four 1000-gallon capacity tanks.

Provision was made to inject known amounts of particulate matter or detergents into the influent to determine their effects on separator operation. A motion table was installed to simulate shipboard motions at sea and to evaluate their effects on separator operation.

The laboratory installation was completed and placed in service in the spring of 1976. Since then, tests have been conducted on several types of oily/water separators including those of the multi-stage coalescent filter types and combination plate separator and coalescent filter types.

2.0 SYSTEM DESCRIPTION

2.1 Influent

Figures 3-1 through 3-14 and Table 1 illustrate the individual components in the system. The major elements and subsystems are described as follows:

2.1.1 Test Water - By breaching and cross connecting SS MAYO LYKE's deep and double bottom tanks, a test water capacity of 225,000 gallons was provided. In addition, for tests requiring lesser volumes of test water, the 25,000 gallon ship's former potable water tank was connected into the loop. From storage, influent water is fed through a 150 gpm centrifugal pump to the test platform. The feed pump may be bypassed completely for those separators having their own installed pump or only partially bypassed to obtain flow rates less than 150 gpm depending upon the rated capacity of the test item.

2.1.2 Test Oils - IMCO specifies that testing shall be performed using both a heavy and a light test oil.

The heavy or No. 1. Test Oil is specified to have a specific gravity of 0.94 at 60°F and a viscosity of about 900 seconds Redwood No. 1 at 100°F. The light or No. 2 Test Oil is specified to have a specific gravity of 0.83.

Four 1000-gallon oil storage tanks were initially installed. Later, as it became apparent that the No. 1 Test Oil of the specific gravity and viscosity range could not be purchased directly, three more tanks, strainers, static mixer, air injection and a pump were installed to permit on-board blending to the No. 1 Test Oil specification, Figure 2. Two oil storage tanks are fitted with immersion heaters for temperature control.

Test oil is injected by taking suction on the oil storage tank with a positive displacement variable speed pump and discharging it through metering valves into the influent stream in the correct amount for the particular test.

2.1.3 Oil Water Mixing - Immediately downstream of the oil injection, a clear pipe section permits a visual indication of the degree of oil/water injection and mixing at that point. Further downstream is a static mixer for more complete mixing of the oil/water if so desired. The static mixer can be bypassed if desired. Another clear section is installed just downstream of the static mixer to provide a visual indication of the oil/water mix just before it reaches the separator under test.

2.2 Effluent

Effluent from the test platform is discharged to storage in deep and double bottom tanks having a total capacity of 225,000 gallons. A cleanup system consisting of a coalescer unit and a sand filter is installed for treatment of the effluent at such time as it is desired to discharge it off the ship or prior to reuse if it is of suitable quality for recirculation.

2.3 Oil Discharge

The separated oil from the test separator is discharged to a 112,000-gallon slop tank where it is held for final disposal.

2.4 Particulate Injection

In order to study the effects of particulate on separator performance, a small separate 15-gallon mixing tank, agitator and two 5-1750 cc/min finger pumps are provided. One of the pumps is used for circulation of the particulate/water slurry maintaining the particulate matter in suspension while the second pump is used to inject the particulate solution into the influent stream between the feed pump discharge and the oil injection stations.

2.5 Detergent Injection

Another separate tank of 250 gallons capacity with its agitator is provided in which detergent or other solutions can be prepared and injected into the suction side of the influent feed pump.

2.6 Motion Simulation

The proposed IMCO specifications call for oily/water separators to demonstrate that they can operate satisfactorily under shipboard

conditions. To investigate the effects of motion on separator operation, a motion table was obtained on a loan basis from the U. S. Navy. This table has the ability to provide motions as follows:

Roll - 15° @ 10, 20 and 30-second periods

Pitch - 5° @ 6.8-second periods

To test the ability of separators to operate at an inclination of 22 1/2° from the vertical in any direction, the separator under test is blocked 7 1/2° and the table is statically inclined to its full 15° while the tests are conducted.

2.7 Instrumentation

The test loop is instrumented to provide the following data:

- Influent water flow rate - GPM
- Test oil injection rate - GPM
- Effluent flow rate - GPM
- Total water used - gallons
- Influent temperature - °F
- Test oil temperature - °F
- Influent pressure - psi
- Test oil pressure - psi
- Effluent pressure - psi
- Effluent quality - ppm by monitor
- Influent and effluent grab samples

2.8 Water and Oil Analysis

In addition to the installed instrumentation, a small chemical laboratory has been installed at the Fire and Safety Test Facility, Mobile, Alabama. This laboratory is used to perform chemical analysis of the test water grab samples using the IMCO specified carbon tetrachloride extraction infrared spectroscopy method utilizing a Beckman IR-33 spectrophotometer.

In addition, there are viscosimeters and hydrometers for determining the specific gravity and viscosity of the test oils.

Other required test oil and water analyses are obtained from local commercial testing laboratories.

2.9 Compressed Air System

A 60 psig, 100 cfm compressed air system is provided to power control air for separators and to power compressed air diaphragm pumps for those separators so equipped.

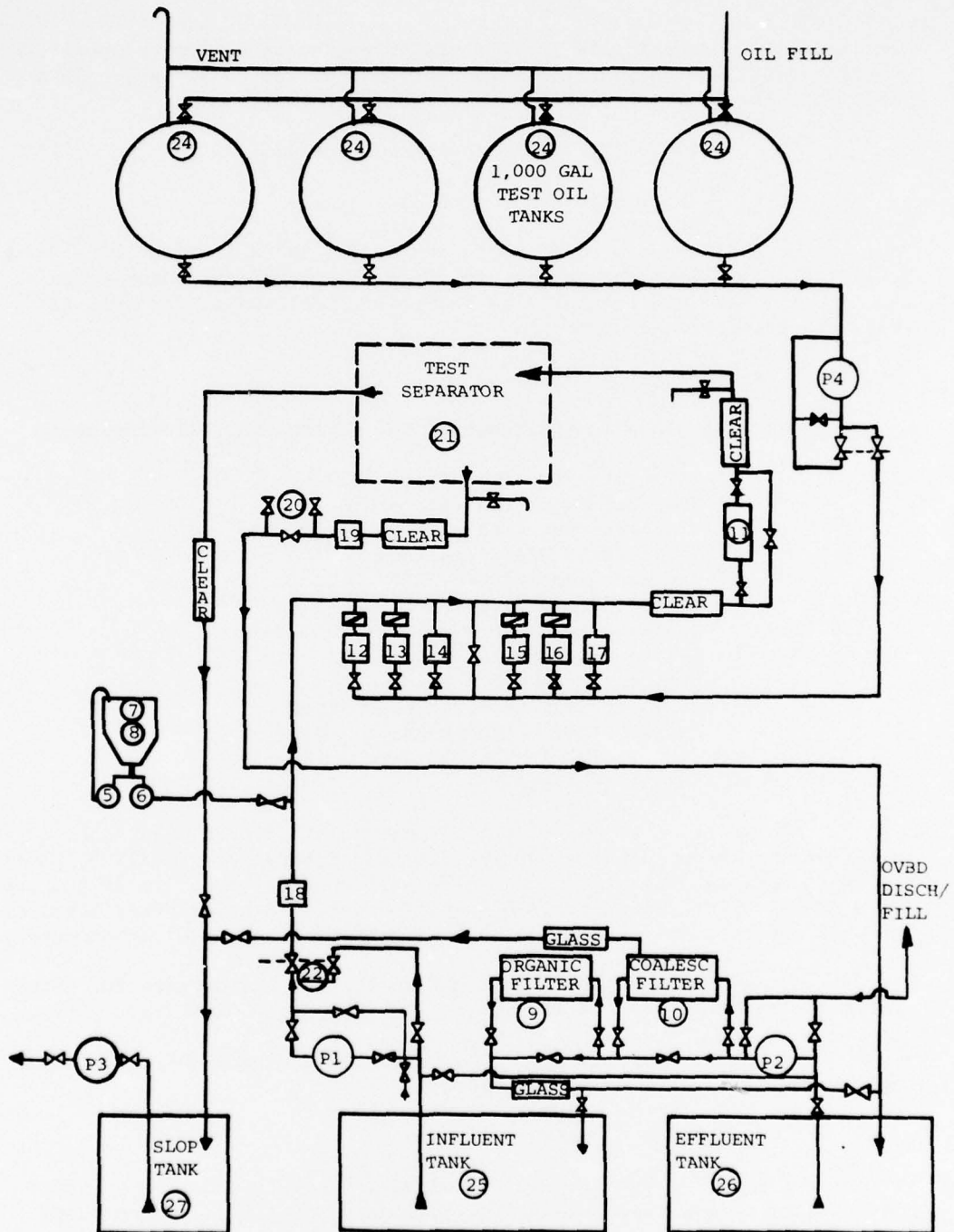

FIGURE 1
SEPARATOR TEST LOOP

<u>ITEM</u>	<u>RANGE</u>	<u>PURPOSE</u>
1. Pump-Centrifugal 7 1/2 HP 3,550 RPM	150 GPM 50 ft Head	Influent
2. Pump-Centrifugal 10 HP 3,550 RPM	100 GPM 100 ft Head	Effluent Transfer
3. Pump-Centrifugal 10 HP 3,550 RPM	100 GPM 100 ft Head	Slop Tank Discharge
4. Pump-Mono 3 HP RPM-VAR	0-10 GPM	Oil Supply
5. Pump-Finger	5-1750 cc/min	Particulate Injection
6. Pump-Finger	5-1750 cc/min	Particulate Injection
7. Portable Agitator		Agitate Particulate
8. Mixing Tank	250 gallon	Particulate Mix
9. Filter-Sand	50-65 GPM	Effluent Cleanup
10. Coalescer	50-65 GPM	Effluent Cleanup
11. Static Mixer	100 GPM	
12. Flowmeter	0-.5 GPM	#2 Oil
13. Flowmeter	.25-3.5 GPM	#2 Oil
14. Flowmeter	2.5-10 GPM	#2 Oil
15. Flowmeter	0.5 GPM	#6 Oil
16. Flowmeter	.25-3.5 GPM	#6 Oil
17. Flowmeter	2.5-10 GPM	#6 Oil
18. Flowmeter		Fresh Water
19. Flowmeter - Fresh Water w/0-100 PPM oil		
20. Connection		For Oil Monitors
21. Test Separator		
22. Water Modulating Valve		Water Flow Control
23. Oil Modulating Valve		Oil Flow Control
24. Test Oil Tanks 4 each	1,000 gal	Test Oil Storage
25. Influent Tank	225,000 gal	Storage
26. Effluent Tank	225,000 gal	Storage
27. Slop Tank	110,000 gal	Storage

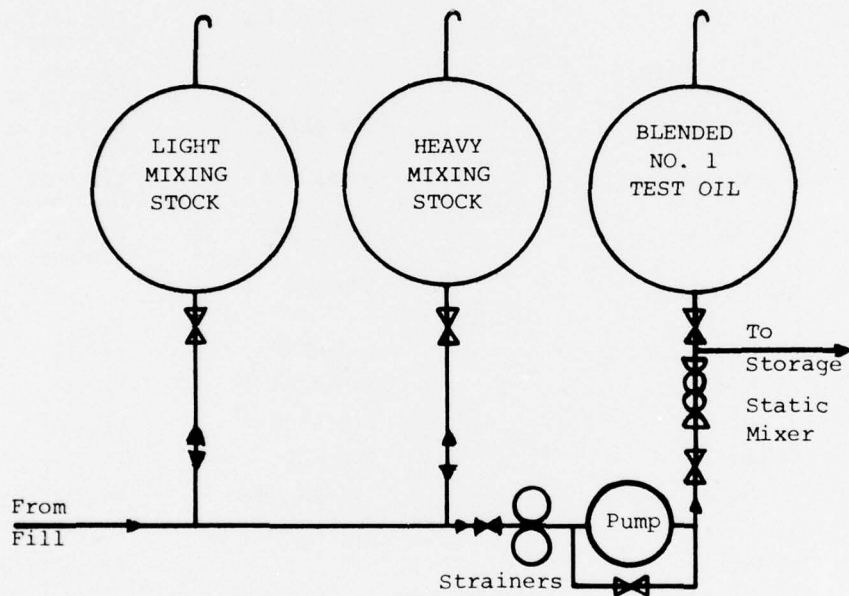

FIGURE 2. DIAGRAMMATIC PLAN OF TEST OIL BLENDING SYSTEM

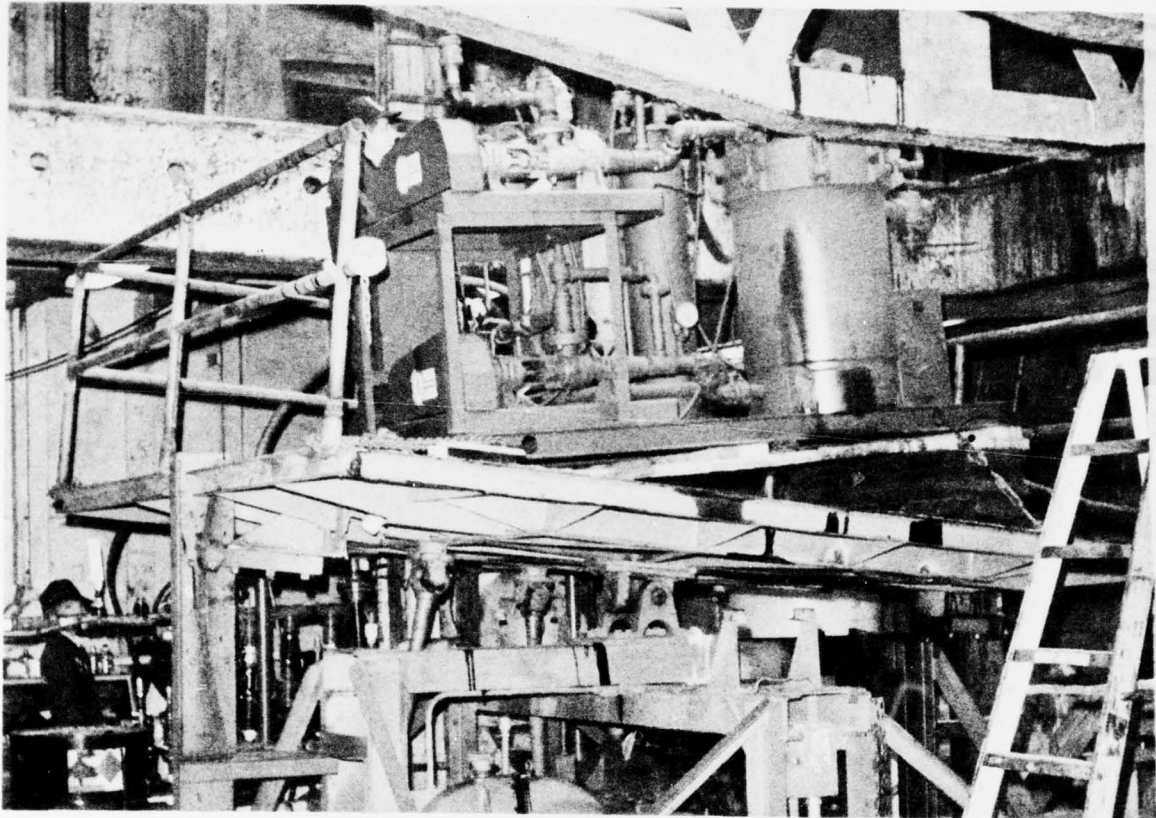

Figure 3-1 SEPARATOR ON INCLINING PLATFORM

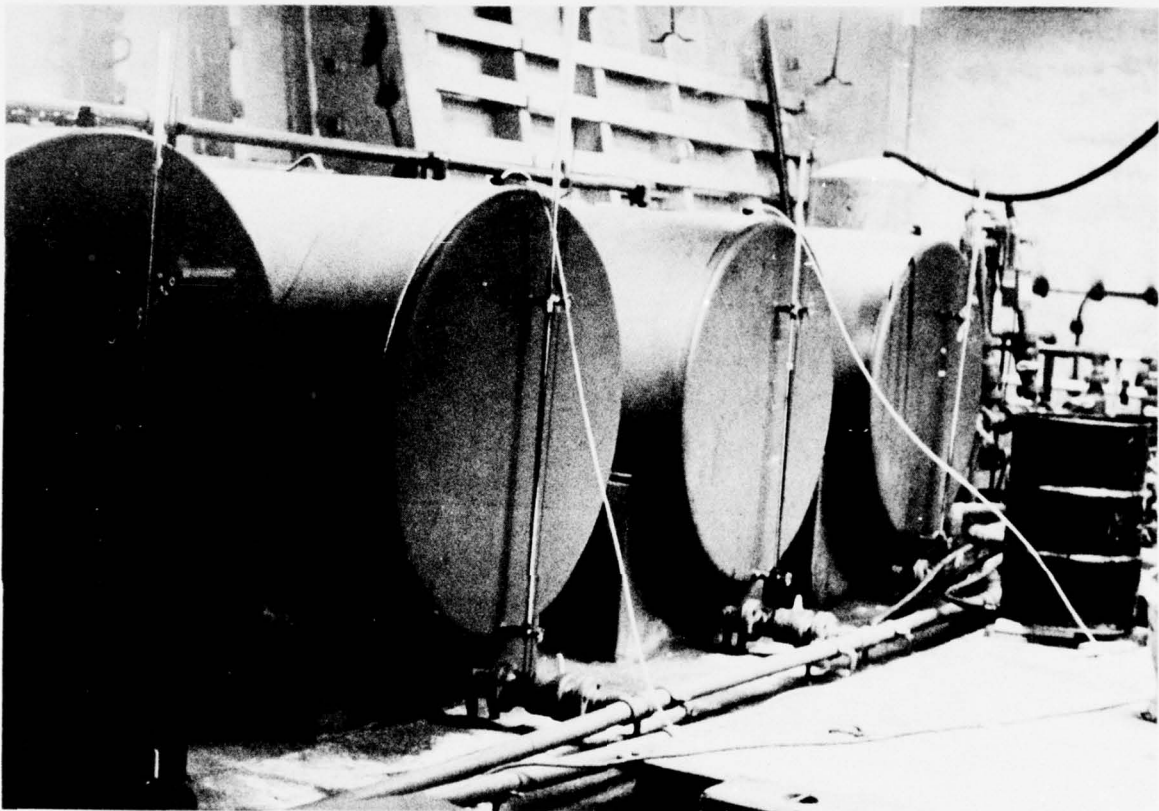

Figure 3-2 TEST OIL STORAGE TANKS

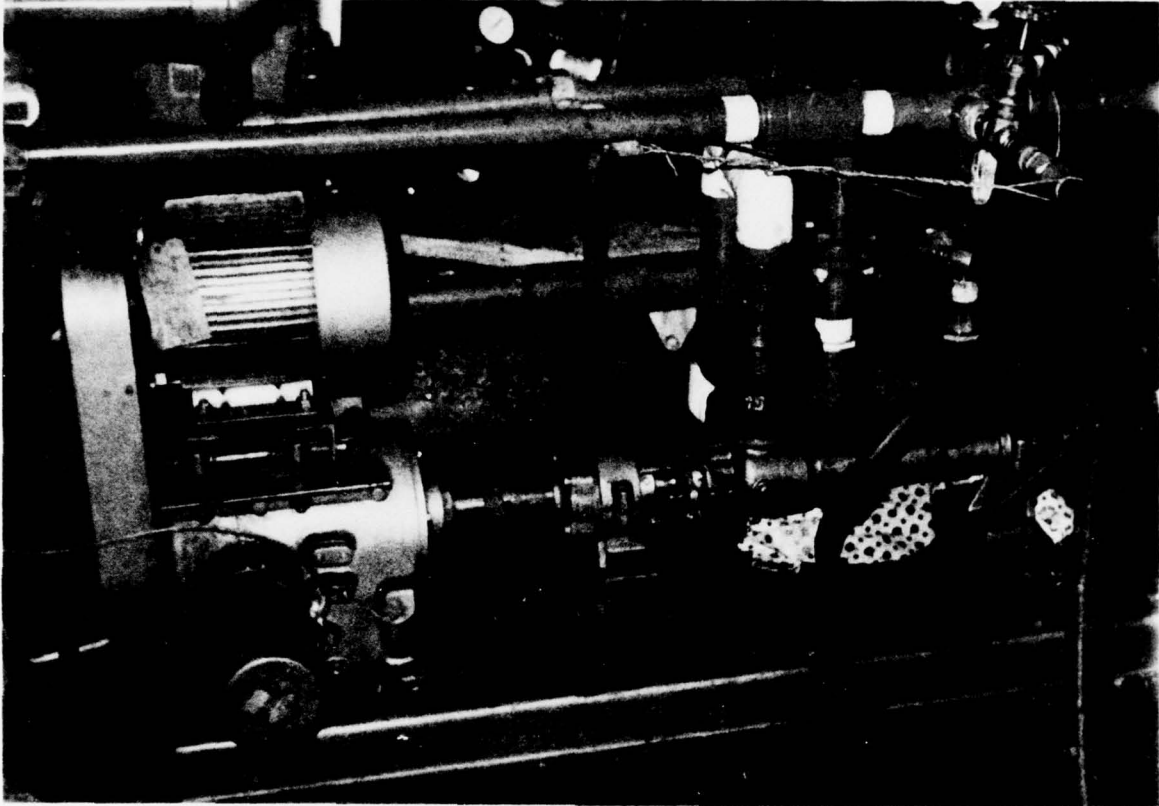

Figure 3-3 TEST OIL INJECTION PUMP

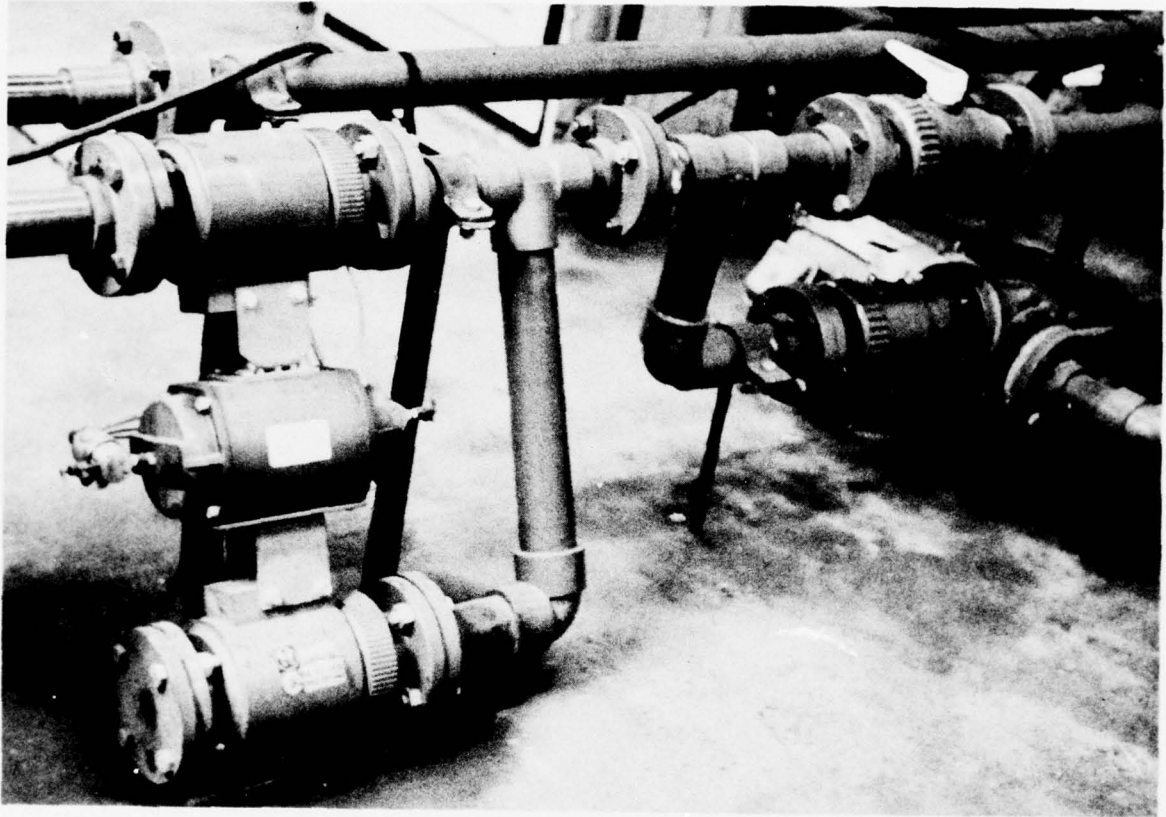

Figure 3-4 INFLUENT PUMP & MODULATING CONTROL

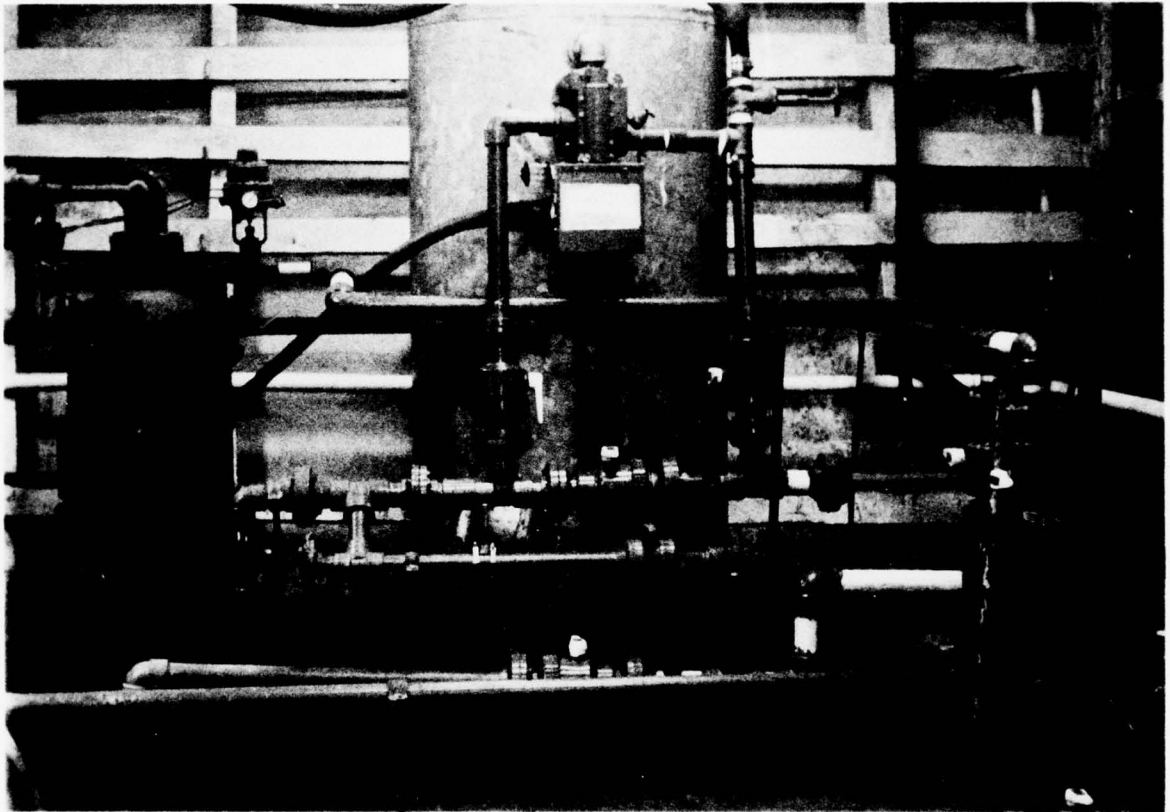

Figure 3-5 EFFLUENT CLEANUP SYSTEM

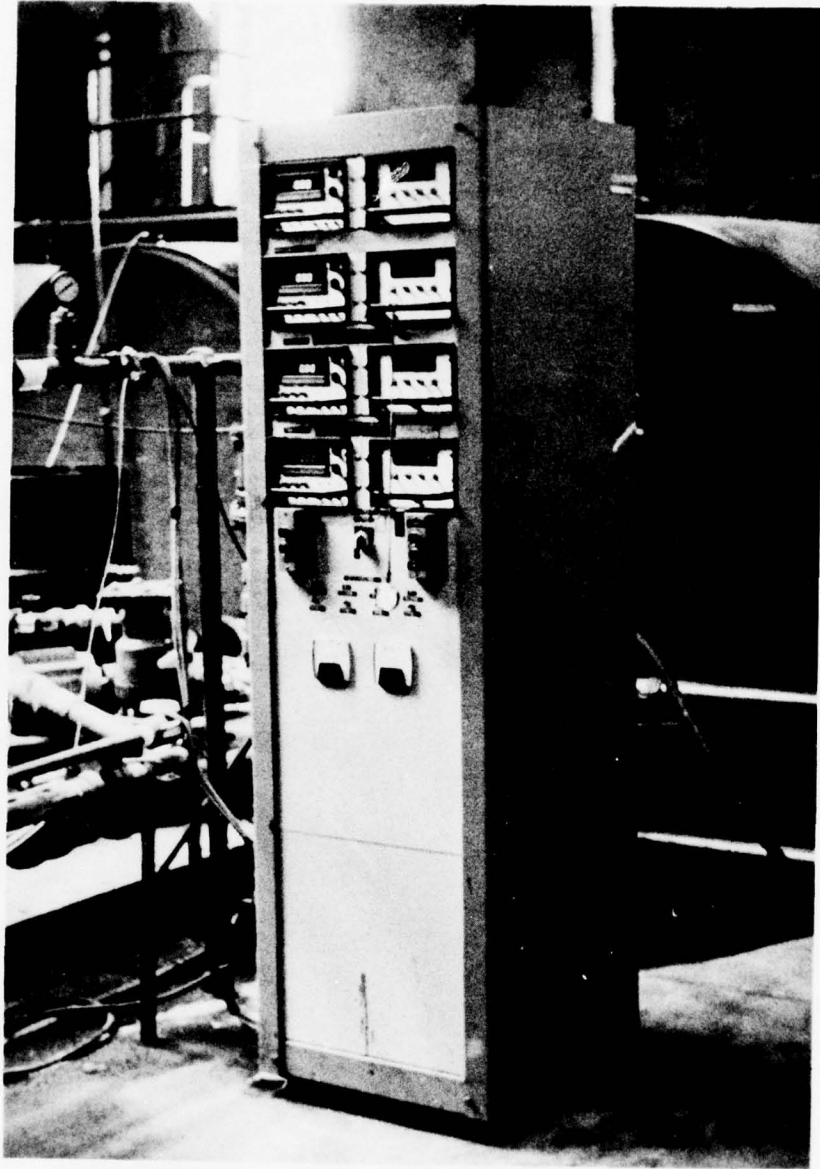

Figure 3-6 INSTRUMENTATION PANEL

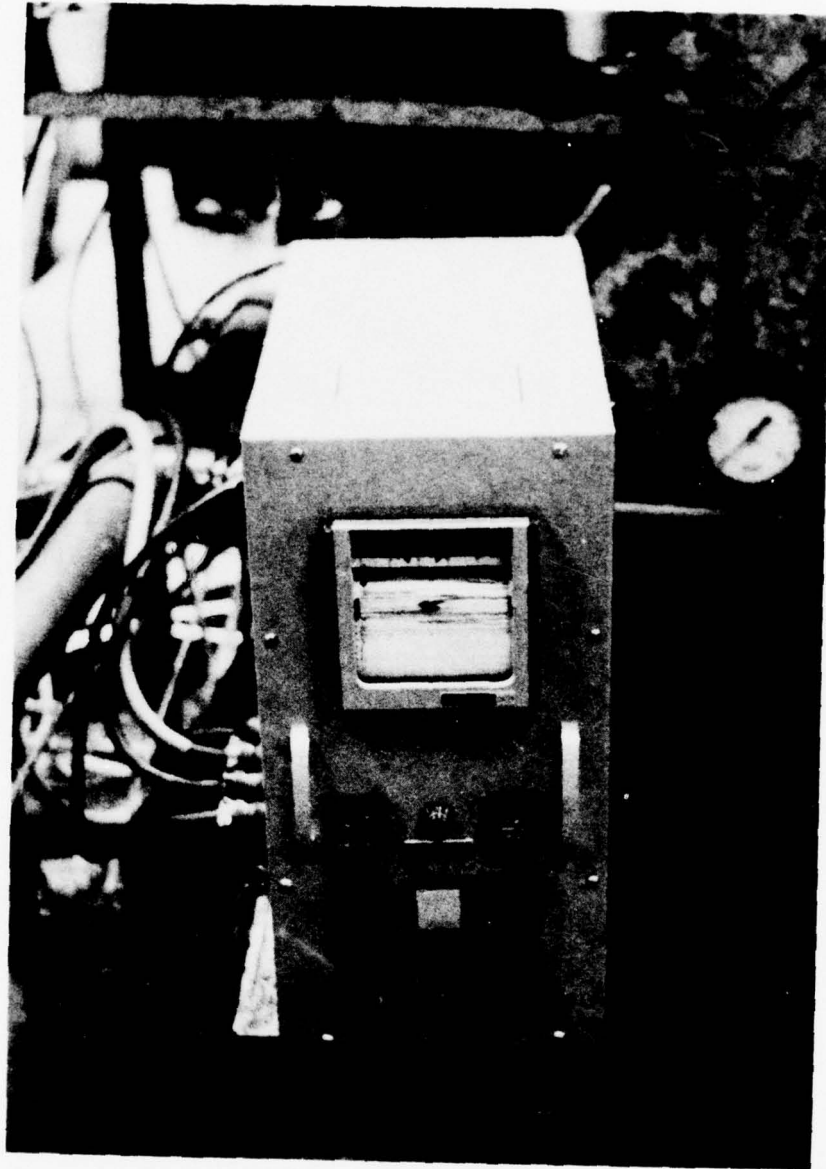

Figure 3-7 IN LINE MONITOR DISPLAY



Figure 3-8 PARTICULATE MIXING TANK

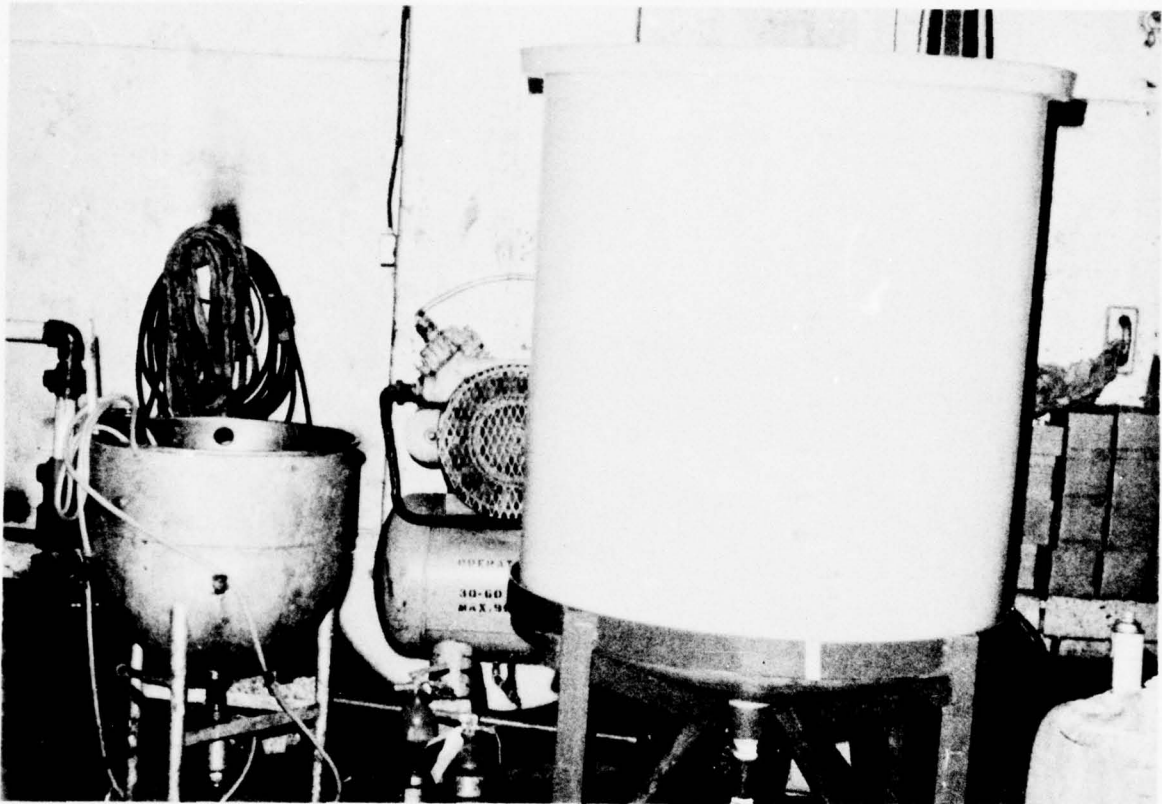

Figure 3-9 AUXILIARY EQUIPMENT:
Particulate Mixing Tank (L.)
Solution Mixing Tank (R.)
Air Compressor (background)

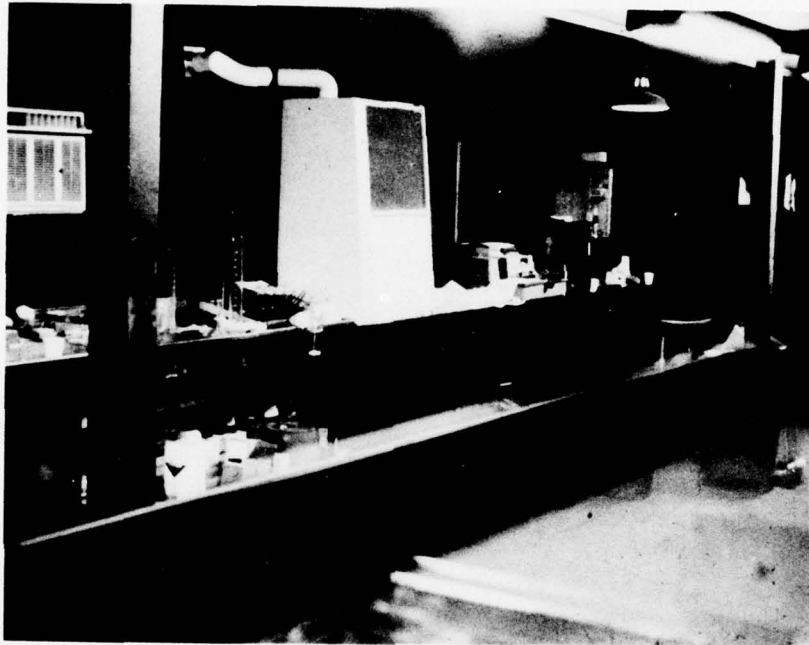

Figure 3-10 GRAB SAMPLE IR ANALYSIS EQUIPMENT

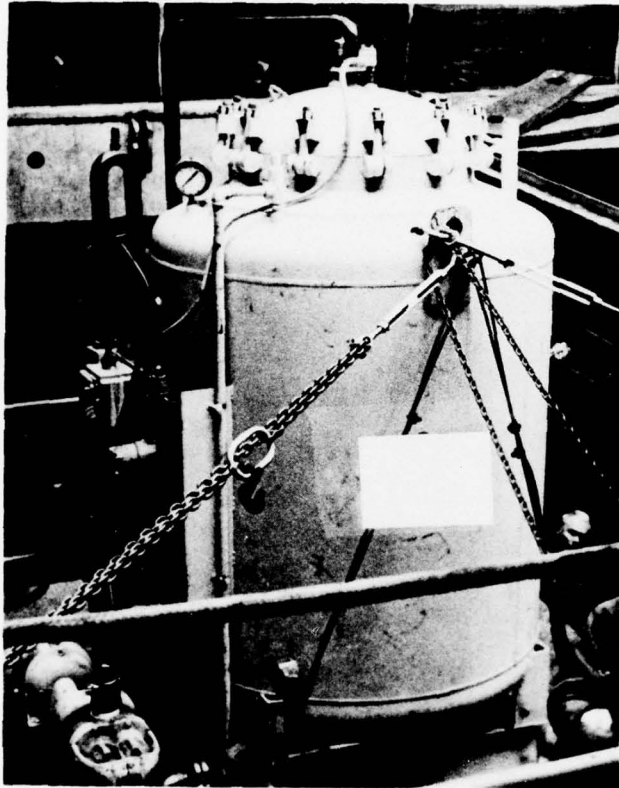

Figure 3-11 50 GPM FILTER TYPE SEPARATOR ON TEST PLATFORM

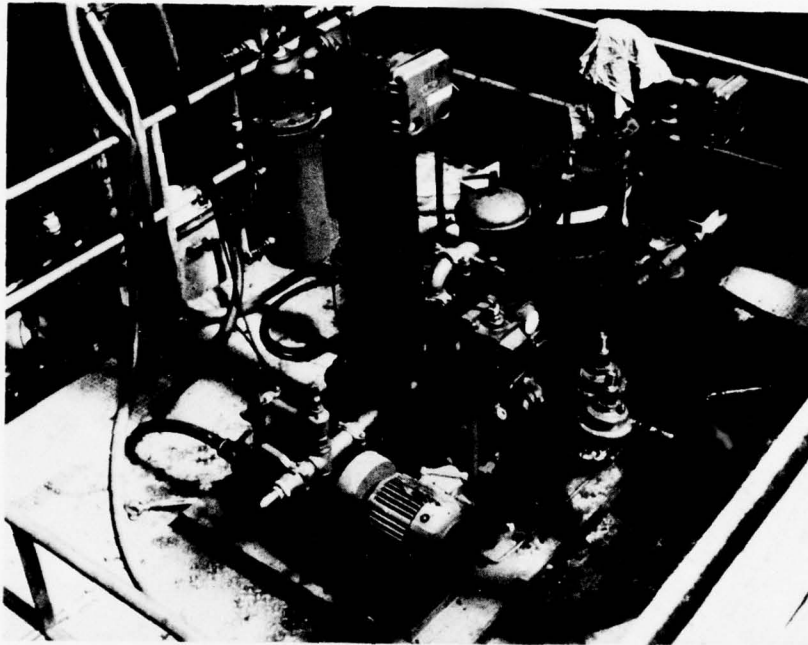

Figure 3-12 COMBINATION PLATE SEPARATOR COALESCER SYSTEM
ON TEST PLATFORM

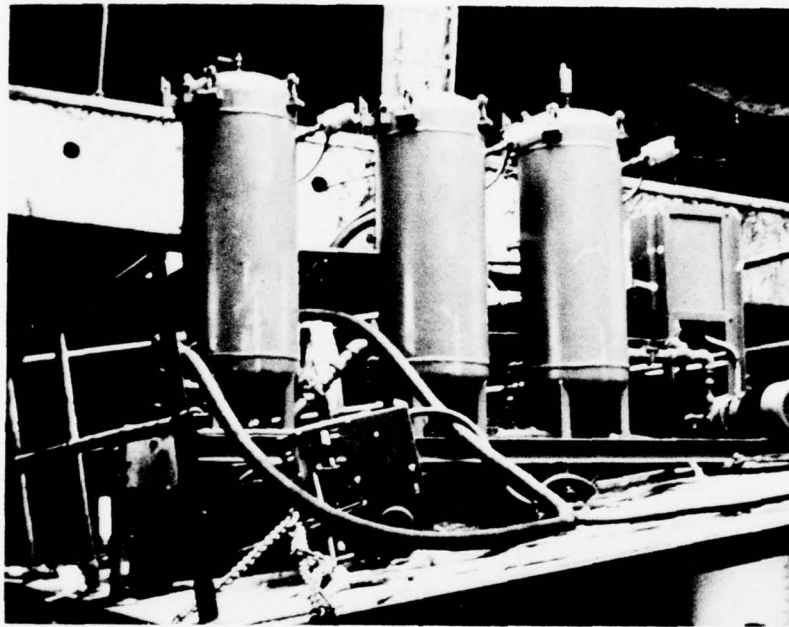

Figure 3-13 THREE-STAGE COALESCER TYPE SEPARATOR ON TEST PLATFORM

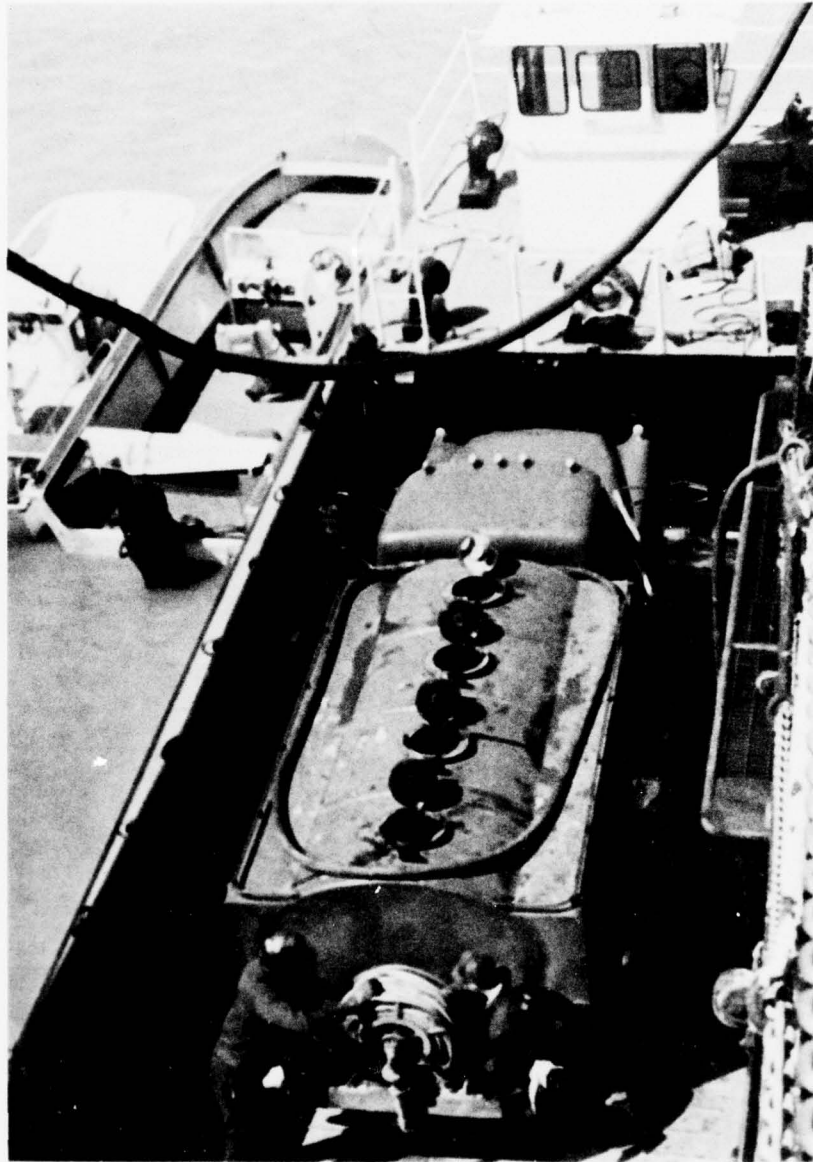

Figure 3-14 HEAVY MIXING OIL STOCK RESUPPLY

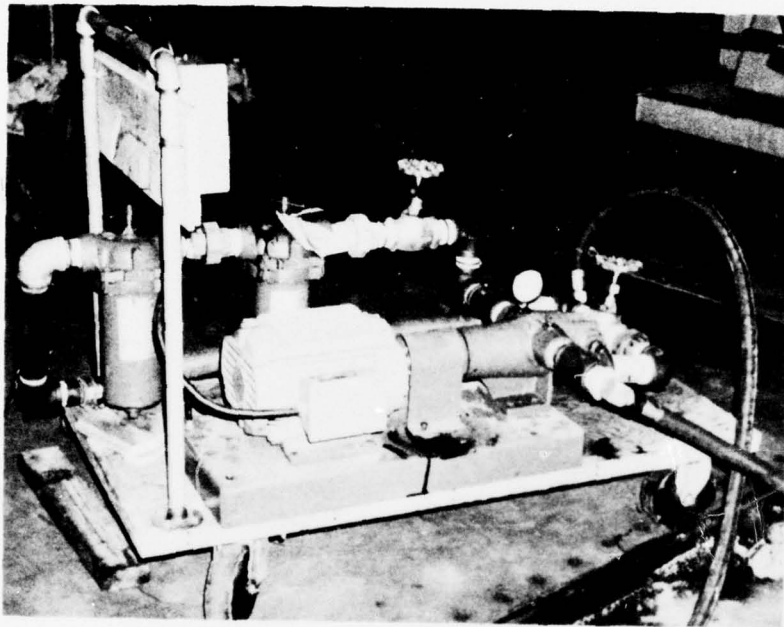

Figure 3-15 TEST OIL BLENDING PUMP

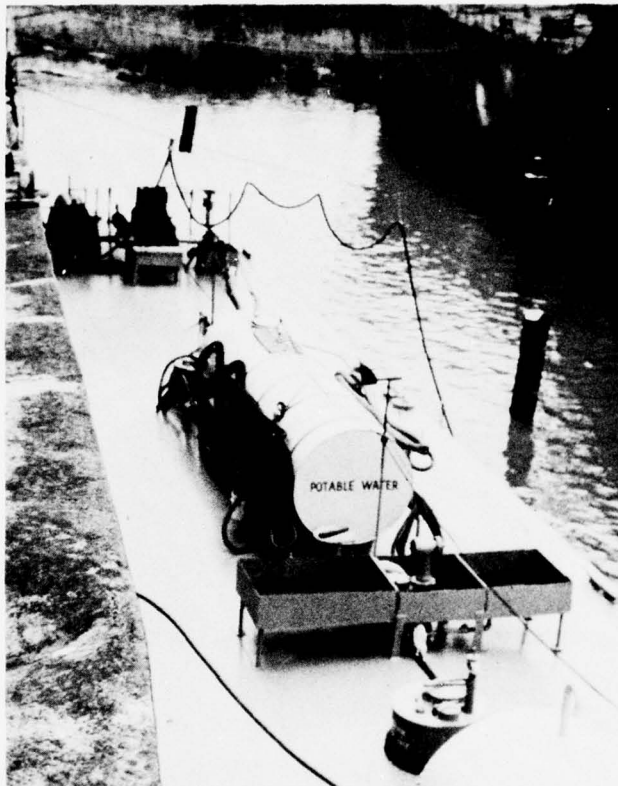

Figure 3-16 NO. 2 TEST OIL AND TEST WATER RESUPPLY

APPENDIX A
PROPOSED IMCO SPECIFICATIONS

MEPC VI/17

ANNEX II

DRAFT RESOLUTION

RECOMMENDATION ON INTERNATIONAL PERFORMANCE AND
TEST SPECIFICATIONS FOR OILY-WATER SEPARATING
EQUIPMENT AND OIL CONTENT METERS

THE ASSEMBLY,

NOTING Article 16(i) of the Convention on the Inter-Governmental Maritime Consultative Organization concerning the functions of the Assembly,

RECALLING Resolution A.233(VII) by which the Assembly adopted the Recommendation on International Performance Specifications for Oily-Water Separating Equipment and Oil Content Meters and invited governments to adopt them to the maximum possible extent which they found reasonable and practicable and to report to the Organization the results of such application,

RECALLING FURTHER that by Resolution A.233(VII) the Maritime Safety Committee was invited to review the Specifications at the appropriate time,

NOTING that in relation to Regulation 16(3) of Annex I of the International Convention for the Prevention of Pollution from Ships, 1973, reference is made to the above-mentioned Specifications,

HAVING CONSIDERED the recommendation submitted by the Marine Environment Protection Committee including the revised Specifications prepared by the Committee in the light of the requirements of Annex I of the 1973 Convention,

ADOPTS the Recommendation on International Performance and Test Specifications for Oily-Water Separating Equipment and Oil Content Meters, the text of which is set out in the Annex to this Resolution, as superseding those contained in Resolution A.233(VII),

INVITES Governments:

- (a) to adopt the revised Specifications and apply them so that all equipment installed on board one year or later after their adoption by the Assembly meets these revised Specifications in so far as is reasonable and practicable; and

MEPC VI/17
ANNEX II
Page 2

- (b) to provide the Organization with information on experiences gained from their application and, in particular, on successful testing of equipment against the Specifications,

REQUESTS the Secretariat on the basis of information received, to maintain and update a list of approved equipment and to circulate it periodically to Governments,

FURTHER INVITES Governments to issue an appropriate "Certificate of Type Test" as referred to in paragraph 1.2.1 in the Specifications and to recognize such Certificates issued under the authority of other Governments as having the same validity as Certificates issued by them.

ANNEX

RECOMMENDATION ON INTERNATIONAL PERFORMANCE AND
TEST SPECIFICATIONS FOR OILY-WATER SEPARATING
EQUIPMENT AND OIL CONTENT METERS

PREAMBLE

1. In response to Resolutions 8 and 12 of the International Conference on Prevention of Pollution of the Sea by Oil, 1962 and to Resolution 10 of the International Conference on Marine Pollution, 1973, which call for formulation of a suitable international performance specification for oily-water separators and the development of a device to detect, measure and record the oil content of discharges from ships, the following specifications have been formulated. Where the word "Convention" is used, this is to be understood as reference to the International Convention for the Prevention of Pollution from Ships, 1973. Where the word "Regulations" is used, this is to be understood as reference to the corresponding regulation of Annex I of that Convention.
2. The specification in respect of oily-water separating and filtering equipment is considered to be applicable especially for use in conjunction with oily bilge water and oily ballast water from fuel oil tanks, as these are of a low or medium capacity, and are conditioned by the need to avoid discharging oily mixture with an oil content of more than 100 parts or 15 parts in 1,000,000 parts of the mixture respectively. The term "Separating Equipment" as used in this specification refers to separators and filters, or any combination of these which are designed to produce effluent containing not more than 100 parts per million (ppm) of oil. The term "Filtering Equipment" as used in this specification refers to filters or any combination of separators and filters which are designed to produce effluent containing not more than 15 ppm of oil.
3. It is recommended that Administrations should implement at an early stage the specifications in so far as it is found reasonable and practicable, with a view to progressing towards its full application. In order to avoid hindrance in the development of improved designs, the specifications will be reviewed after a reasonable period of operation taking account of the experience gained from its use.

4. The 100 ppm criterion is considered to be a desirable goal for all separating equipment regardless of capacity. It is recognized, however, that the development and testing of high capacity separating equipment designed for dealing with effluent from cargo tanks on tankers poses special problems and such equipment does not require to be tested under this specification. Such development and test should not be hindered and Administrations should be prepared to accept deviations from this specification where they are considered necessary in this context.

5. It should be understood that a gravitational separator cannot be expected to be effective over the complete range of oils which might be carried on board ship, nor can it deal satisfactorily with oil of very high relative density or with a mixture presented to it as an emulsion. Detergents should not be used in the bilges for cleaning purposes, as the emulsifying effects of such compounds seriously affect the operation of the equipment. Particulate matter can also have a detrimental effect on equipment performance.

6. The specification for oil content meters represents a desirable, achievable goal and should be recommended by Administrations to designers and manufacturers of such meters. Such meters will be of greatest value in tankers, for avoiding contravention of the Convention, when discharging dirty ballast and tank washings from cargo oil tanks, although the way has been left open for further developments in the design of separating and filtering equipment for this purpose.

PART I. GENERAL

1.1 Contents

The specifications set out in this Recommendation are in three parts as follows:

- Part II - Specification for Oily-Water Separating and Filtering Equipment.
This specification is intended to include both basic constructional details and the test procedures for oily-water separators, filters and necessary ancillary equipment

for shipboard use, so that the vessel so fitted is not likely to infringe that part of the Convention which defines the oil content of any discharged water as the permissible limit. Having regard to the need to deal primarily with effluent from machinery space bilges and from tanks which have been used alternately as fuel tanks and water ballast tanks, the tests are designed with a view to complying with the requirement that the oil content of the discharge should be not more than 100 ppm. Filtering equipment should be designed in order to produce effluent containing not more than 15 ppm.

Part III - Specification for Oil Content Meters

During the discharge of effluent which might contain oil the need arises for an instrument to measure continuously the oil content of the effluent in the line, to ensure that the operation does not contravene the provisions of the Convention. The aim of this specification is to lay down the most important features of the design and the method of testing such oil content meters (hereinafter called "the meter").

Part IV - Method for the Determination of Oil Content

1.2 General Provisions

- 1.2.1 Apparatus which in every particular fulfils the requirements of the present specifications may be approved by the Administration of the manufacturer's country for fitting on board ships. The approval should take the form of a "Certificate of Type Test" specifying the main particulars of the apparatus and any limiting conditions on its usage necessary to ensure its proper performance. In the case of each size of equipment the certificate should specify the maximum throughput for which it has been approved. After the issue of such a certificate a copy of the appropriate certificate for the apparatus should be carried aboard any vessel so fitted at all times.

- 1.2.2 Approved apparatus may be accepted by other countries for use on their vessels on the basis of the first trials, or after fresh tests carried out under the supervision of their own representatives. Should separating or filtering equipment or an oil content meter pass a test in one country, and fail a test of a similar nature in another country, then the two countries concerned should consult one another with a view to coming to an agreement which could be mutually acceptable.
- 1.2.3 Where a range of separating or filtering equipments of the same design, but of different capacities, requires certification in accordance with this specification and where the largest capacity in the range does not exceed 50 cubic metres/hour, the Administration may accept tests in two capacities within the range, in lieu of tests on every size, provided that the two tests actually performed are from the lowest quarter and highest quarter of the range.

PART II. SPECIFICATION FOR OILY-WATER SEPARATING AND FILTERING EQUIPMENT

2.1 Technical Specification

- 2.1.1 This specification relates primarily to separators and filters of low to medium capacity. Separating equipment should be capable of giving an effluent containing not more than 100 ppm of oil irrespective of the oil content (from 0 to 100 per cent) of the feed supplied to it. Filtering equipment should be capable of reducing the oil content in the effluent to not more than 15 ppm.
- 2.1.2 The equipment should be strongly constructed and suitable for shipboard use, bearing in mind its intended location on the ship.
- 2.1.3 The satisfactory functioning of the equipment should not be affected by the movements and vibrations experienced on board ship. In particular, electrical and electronic alarm and control arrangements should be tested to show that they are at least capable of continued operation under vibration conditions as follows:

- (i) from 2 Hz - 13.2 Hz with an amplitude of ± 1 mm, and
- (ii) from 13.2 Hz - 80 Hz with an acceleration amplitude of ± 0.7 g.

Additionally the equipment should be capable of reliable operation at angles up to 22.5° in any plane from the normal operational position.

- 2.1.4 It should, if intended to be fitted in locations where flammable atmospheres may be present, comply with the relevant safety regulations for such spaces. Any electrical equipment which is part of the equipment should be placed in a non-hazardous area, or should be certified by the Administration as safe for use in a hazardous area. Any moving parts which are fitted in hazardous areas should be arranged so as to avoid the formation of static electricity.
- 2.1.5 The equipment should be so designed that it functions automatically. However, provision should be made for emergency manual control.
- 2.1.6 Changing the feed to the separating equipment from oily water to oil, or from oil and/or water to air should not result in the discharge overboard of any mixture containing more than 100 ppm of oil. In the case of filtering equipment the oil content in the discharge overboard should not be more than 15 ppm under the same circumstances.
- 2.1.7 The system should require the minimum of attention to bring it into operation. In the case of equipment used for engine room bilges, there should be no need for any adjustment to valves and other equipment to bring the system into operation and, when fitted in unattended machinery spaces, the system should be capable of operating for at least 24 hours of normal duty without attention.
- 2.1.8 All working parts of the equipment which are liable to wear or to damage should be easily accessible for maintenance.

2.2 Test Specification

2.2.1 These test standards refer to separating or filtering equipment of low or medium capacity.

2.2.2 The oil/water mixture, with which the system has in practice to deal, depends on:

- (i) the position of the oil/water interface, with respect to the suction point, in the space being pumped;
- (ii) the type of pump used;
- (iii) the type and degree of closure of any control valve in the circuit; and
- (iv) the general size and configuration of the system.

It is therefore desirable that the test rig be so constructed as to include not only the separating and filtering equipment, but also the pump and the most important of the valves, pipes, etc. ... (for an example see Figure 1). The pipework should be designed for a maximum liquid velocity of 3 m/s.

2.2.3 The tests should be carried out with a supply rate equal to the full throughput for which the equipment is designed.

2.2.4 Tests should be performed using two grades of oil. All the tests should be carried out using a fuel oil of a relative density of about 0.94 at 15°C and of a viscosity not less than 220 centistokes (about 900 seconds Redwood No.1) at 37.8°C (100°F). In addition, the tests described in 2.2.10 and 2.2.11 should be carried out using a light distillate fuel oil having a relative density of about 0.83 at 15°C.

2.2.5 If the equipment includes an integrated feed pump fitted before or after the separator, this equipment should be tested with that pump supplying the required quantity of oil and water to the equipment

at its rated capacity. If the equipment is to be fed by the ship's bilge pumps, then the unit will be tested by supplying the required quantity of oil and water mixture to the inlet of a centrifugal pump operating at not less than 1,000 rpm. This pump should have a delivery capacity of not less than 1.5 times the rated capacity of the equipment at the delivery pressure required for the test. The variation in oil/water ratio will be obtained by valves on the oil and water suction pipes adjacent to the pump suction, and the flow rate of oil and water or the oil content of the supply to the equipment should be monitored. If a centrifugal pump is used, the excess pump capacity should be dissipated by either a by-pass to the suction side, or by a throttle valve or standard orifice plate on the discharge side. In all cases, to ensure uniform conditions, the piping arrangements immediately prior to the equipment should be such that the influent to the equipment should have a Reynolds Number of not less than 10,000 as calculated in fresh water, a liquid velocity of not less than 1 m/s and the length of the supply pipe from the point of oil injection to the equipment should have a length not less than 20 times its diameter. A mixture inlet sampling point and a thermometer pocket should be provided near the equipment inlet and an outlet sampling point and observation window should be provided on the discharge pipe. Figure 1 gives diagrammatic representations of two possible test rigs though it should be noted that the water and oil from the equipment need not be led back to the supply tanks. Where the water and oil are re-circulated during the test, additional sampling points should be fitted in the water and oil lines to the mixture pump in order to check the quality of the water and oil being supplied to the pump.

In order to approach isokinetic sampling, i.e. the sample enters the sampling pipe at stream velocity, the sampling arrangement should be as shown in Figure 2 and, if a cock is

fitted, free flow should be effected for at least 1 minute before any sample is taken. The sampling points should be in pipes running vertically.

- 2.2.6 The tests should be carried out with clean water having a relative density at 15°C not more than 0.085 greater than the relative density of the heavier fuel oil detailed in 2.2.4.
- 2.2.7 In the case of equipment depending essentially on gravity the feed to the system should be maintained at a temperature not greater than 25°C, and heating and cooling coils should be provided where necessary. In other forms of separation where the dependence of separation efficiency on temperature is not established, tests should be carried out over a range of temperatures representing the normal shipboard operating range 10°C to 30°C or should be taken at a temperature in this range where the separation efficiency is known to be worst.
- 2.2.8 In those cases where, for the equipment, it is necessary to heat water up to a given temperature and to supply heat to maintain that temperature, the tests should be carried out at the given temperature.
- 2.2.9 To ensure that the equipment commences the test with the oil section full of oil and with the supply line impregnated with oil, the equipment should, after filling with water and while in the operating condition, be fed with pure oil for not less than five minutes.
- 2.2.10 The equipment should be fed with a mixture composed of between 5,000 and 10,000 ppm of oil in water until steady conditions have been established. Steady conditions are assumed to be the conditions established after pumping through the separating equipment a quantity of oil/water mixture not less than twice the volume of the equipment. The test should then proceed for 30 minutes during which time samples should be taken for analysis at the

points of mixture inlet and the water outlet at 10 minutes and 20 minutes from the start of this period. At the end of this test, an air cock should be opened on the suction side of the pump and, if necessary, the oil and water valves should be slowly closed together, and a sample taken at the water discharge as the flow ceases (this point can be checked from the observation window).

- 2.2.11 A test identical to that described in 2.2.10 above, including the opening of the air cock, should be carried out with a mixture composed of approximately 25 per cent oil and 75 per cent water.
- 2.2.12 The equipment should be fed with 100 per cent of oil for at least 5 minutes during which time the observation window should be checked for any oil discharge. Sufficient oil should be fed into the equipment to operate the automatic oil discharge valve. After the operation of the oil discharge valve, the test should be continued for 5 minutes using a 100 per cent oil supply in order to check the sufficiency of the oil discharge system.
- 2.2.13 The equipment should be fed with water for 15 minutes and two samples should be taken during operation at the water outlet, the first one to be immediately after the changeover.
- 2.2.14 A test lasting a minimum of three hours should be carried out to check that the equipment will operate continuously and automatically. This trial should use a cycle varying progressively from water to oily mixture with approximately 25 per cent oil content and back to water every 15 minutes, and should test adequately any automatic device which is fitted. The whole test sequence should be performed as a continuous programme. At the end of the test, while the equipment is being fed with 25 per cent oil, a water effluent sample should be taken for analysis.

- 2.2.15 Sampling should be carried out as shown in Figure 2 so that the sample taken will suitably represent the fluid issuing from the water outlet of the equipment.
- 2.2.16 Flasks containing samples should be sealed and labelled in the presence of a representative of the national authority and arrangements should be made for analysis as soon as possible and in any case within seven days, at laboratories selected by the Administration.
- 2.2.17 The oil content of the samples should be determined by the method in Part IV.
- 2.2.18 When accurate and reliable oil content meters are fitted at inlet and outlet of the separating or filtering equipment, one sample at inlet and outlet taken during each test will be considered sufficient if they verify, to within ± 10 per cent, the meter readings noted at the same instant.
- 2.2.19 In the presentation of the results, the following data should be reported in the International Metric System of Units:
- (i) Properties of the oil:
 - relative density at 15°C
 - viscosity (centistokes at 37.8°C)
 - flashpoint
 - ash
 - water content (total);
 - (ii) Properties of the water:
 - relative density at 15°C with details of any solid matter present;
 - (iii) Temperature at the inlet to the equipment;
 - (iv) The method used in analysis of all samples taken and the results thereof together with meter readings where appropriate;
 - (v) A diagram of the test rig; and
 - (vi) A diagram of the sampling arrangement.

2.3 Installation Requirements

- 2.3.1 For future inspection purposes aboard ship, a sampling point should be provided in a vertical section of the water effluent piping as close as is practicable to the equipment outlet.
- 2.3.2 Means should be taken to ensure that, in practice, the rated capacity of the equipment is not exceeded by:
- (i) connecting only pumps of a capacity equal to, or less than, that of the equipment, or
 - (ii) permanently restricting the discharge to the equipment where larger pumps may be connected.
- 2.3.3 In any case, equipment should not be supplied from a pump which has a capacity more than 1.5 times the rated capacity of the equipment.
- 2.3.4 The equipment should be fitted with a permanently attached plate giving any operational or installation limits considered necessary by the manufacturer or the Administration.

PART III. SPECIFICATION FOR OIL CONTENT METERS

3.1 Technical Specification

- 3.1.1 This specification relates to oil content meters for a wide range of oil content and oil content alarms for 15 ppm. A meter may, however, be tested for one or several specified applications, i.e. crude oils, "black" products, "white" products, bilge water or "15 ppm alarm"; and the approval should clearly indicate the accepted application(s).
- 3.1.2 The meter should be a robust and practical instrument suitable for shipboard installation and operation. It should withstand normal stresses due to the ship's motion (rolling and pitching) and its operation must not be affected by such motion. It should be designed and fitted so that the vibration normally occurring on board will not affect its operation. Unless it can be shown to be unnecessary the meter and any associated equipment, particularly electrical

and electronic alarm and control arrangements, should be tested to show that it is capable of continued operation under vibration conditions as follows:

- (i) from 2 Hz - 13.2 Hz with an amplitude of ± 1 mm, and
- (ii) from 13.2 Hz - 80 Hz with an acceleration amplitude of ± 0.7 g.

Additionally, the equipment should be capable of reliable operation at angles up to 22.5° in any plane from the normal operational position.

- 3.1.3 It should resist corrosion in conditions of the marine environment.
- 3.1.4 It should, if intended to be fitted in locations where flammable atmospheres may be present, comply with the relevant safety regulations for such spaces. Any electrical equipment which is part of the meter should be placed in a non-hazardous area, or should be certified by the Administration as safe for use in a hazardous atmosphere. Any moving parts which are fitted in hazardous areas should be arranged so as to avoid the formation of static electricity.
- 3.1.5 It should not contain or use any substance of a dangerous nature, unless adequate arrangements, acceptable to the Administration, are provided to eliminate any hazard introduced thereby.
- 3.1.6 The accuracy of meters designed to monitor a wide range of oil content should be such that the reading will represent within ± 10 ppm or ± 20 per cent of the actual oil content of the sample being tested, whichever is the greater. The accuracy should remain within the above limit despite the presence of contaminants other than oil, such as entrained rust, mud and sand. When a vessel is fitted with filtering equipment in accordance with Regulations 16(2)(b) and 16(7) of Annex I of the Convention, an alarm is to be provided which will indicate when the oil content of the effluent exceeds 15 ppm. The accuracy of the alarm should be ± 5 ppm. The alarm arrangement should be tested in accordance with paragraph 3.2.18 of this specification.

- 3.1.7 It should be designed so that it functions within the above limit when the power supply is varied by 10 per cent from the value for which the meter was designed, i.e. in respect of electricity, compressed air, etc.
- 3.1.8 It is desirable that the reading should not be affected by the type of oil. If it is, it should not be necessary to calibrate the meter on board ship, but pre-set alterations in the calibration in accordance with instructions drawn up at the time of manufacture, are permitted.
- In the latter case, means should be available to check that the correct calibration has been selected for the oil in question. The accuracy of the readings should at all times remain within the limit specified in 3.1.6.
- 3.1.9 The response time of the meter, that is, the time which elapses between an alteration in the sample being supplied to the meter and the meter showing the correct response, should not exceed 20 seconds.
- 3.1.10 The meter may have several scales as appropriate for its intended use.
- 3.1.11 The meter should be fitted with an alarm device which can be set to operate automatically at any pre-stated value either to alert the crew of the ship or to operate control valves. This alarm should also operate automatically if at any time the meter should fail to function.
- 3.1.12 It is recommended that a simple means be provided aboard ship to check on instrument drift, and to confirm the accuracy and repeatability of the instrument reading.
- 3.1.13 When a recording device is fitted to a meter which has more than one scale, the recording device should indicate the scale which is in use.

3.2 Test Specification

- 3.2.1 For a meter designed to measure a wide range of oil content the meter reading should remain within ± 10 ppm or ± 20 per cent whichever is the greater of the true oil content of the sample entering the meter during each test, and testing should be performed in accordance with the procedures detailed in 3.2.4 to 3.2.17. For a meter designed only to give an alarm at 15 ppm the accuracy should be within ± 5 ppm and testing should be performed in accordance with the procedures in 3.2.18.
- 3.2.2 The sampling arrangement should be such that a representative homogeneous sample is obtained under all conditions of operation and under all operational proportions of oil content.
- The sample should be obtained from the full flow through the meter but when this is impracticable the sampling arrangements shown in Figure 2 should be used. Special care should be given to this stage of the process and the validity of the resultant findings.
- 3.2.3 During the various tests the response time of the meter should be checked and it should also be noted whether alarms operate adequately when a pre-stated threshold is exceeded.
- 3.2.4 A diagrammatic arrangement of a test facility for evaluating the performance of oil content meters is given in Figure 3. The accuracy of the oil content meter will be determined by comparing its readings against a known flow of oil injected into a known flow of water. The grab samples taken will be analysed in a laboratory by the method in Part IV. The results of the laboratory analysis will be used for correlation and to indicate sampling and test equipment variability. The water flow rate will be adjusted so that the entire oil-water flow passes through the oil content meter, except the intermittent grab sample stream. Special care should be given to keep, continuously, a constant oil content in the water

that flows into the meter. The oil and contaminant metering pumps should be adjusted to deliver a nearly continuous quantity of oil. If oil injection becomes intermittent at low concentrations, the oil may be premixed with water to provide continuous flow if absolutely necessary. The oil injection point should be immediately up-stream of the oil content meter inlet to minimize time lags caused by the sample system. Wherever Arabian light crude oil is specified in particular tests, a similar crude oil may be substituted, provided that the oil selected is used throughout the tests.

3.2.5 The oil content meter will be calibrated and zeroed as per the manufacturer's instructions. It will then be tested with Arabian light crude oil at the following concentrations in ppm: 0, 15, 50, 100, etc., up to full scale of the meter's highest range. A complete calibration curve will be constructed. Each concentration test will last for 15 minutes. Following each concentration test, the meter will be run on oil-free water for 15 minutes and the reading noted. If it proves necessary to rezero or re-calibrate the meter during this test, this fact will be noted.

3.2.6 Using the calibration from the previous test, the oil content meter will be tested at 15 ppm, 100 ppm and 90 per cent of the maximum full scale with the following oils:

<u>Type of Oil</u>	<u>Categories Represented</u>
Sahara Blend	Density - Low Viscosity - Low Pour Point - Very Low Producing Country - Algeria General Description - Mixed Base
Arabian Light Crude	Density - Medium Viscosity - Medium Pour Point - Low Producing Country - Saudi Arabia General Description - Mixed Base

<u>Type of Oil</u>	<u>Categories Represented (Continued)</u>
Nigerian Medium Crude	Density - High Viscosity - Medium Pour Point - Low Producing Country - Nigeria General Description - Napthenic
Bachaquero 17 Crude	Density - Very High Viscosity - Very High Pour Point - Low Producing Country - Venezuela General Description - Asphaltic
Minas Crude	Density - Medium Viscosity - High Pour Point - Very High Producing Country - Indonesia General Description - Paraffinic
Residual Fuel	Dunker C or No.6 Fuel Oil

Note: Other oils covering the range of properties shown may be substituted if those shown are unobtainable.

Following each test, the meter will be run on oil-free water and the zero recorded. If it is necessary to rezero, calibrate or clean the meter between tests, this fact and the time required to calibrate or clean-up will be noted.

- 3.2.7 If the meter is considered suitable for products, it will also be tested against the following petroleum products in a manner similar to the tests in 3.2.6:

Leaded Regular Grade Automotive Gasoline
Unleaded Automotive Gasoline
Kerosene
Light Diesel or No.2 Fuel Oil.

3.2.8 The oil content meter will be run on oil-free water and zeroed. The oil injection pump, set to 100 ppm of Arabian light crude oil, will be turned on. The following response times will be recorded:

- (i) Time for first detectable reading.
- (ii) Time to read 63 ppm (response time).
- (iii) Time to read 90 ppm.
- (iv) Time to read 100 ppm or for reading to stabilize at maximum.

Record the maximum reading.

Following this upscale test, the oil injection pump will be turned off, and the following response times will be recorded:

- (i) Time for the maximum reading to drop detectably.
- (ii) Time to read 37 ppm (response time).
- (iii) Time to read 10 ppm.
- (iv) Time to read zero or to stabilize at minimum.

Record the minimum reading.

The "Response Time" of the meter will be considered the average of the 63 ppm upscale and the 37 ppm downscale response times.

3.2.9 Two tests will be performed for oil fouling and calibration shift, one with a 10 per cent oil concentration, and the other with pure oil. Both tests will use Arabian light crude oil.

For the 10 per cent oil concentration test, the meter will be running on oil-free water. The high rate oil sample pump, set to give 10 per cent oil in water, will be turned on for one minute and then turned off.

For the pure oil test, the meter will be running on oil-free water. The water will be turned off, and 100 per cent oil will be turned on for one minute. The oil will then be turned off and the oil-free water flow resumed.

Care must be taken in the design of the test equipment to be sure the fouling test results are not degraded by fouling of the sample piping external to the meter.

The following response times will be noted for both tests:

- (i) First detectable response.
- (ii) 100 ppm.
- (iii) Off scale on the highest range.
- (iv) Back on scale on the highest range.
- (v) Return to 100 ppm.
- (vi) Zero reading or lowest stable reading.

The meter should be capable of being cleared with clean water flushing in the shortest practicable time.

If it is necessary to disassemble or flush the meter after the fouling tests for it to return to a zero reading, this fact and the time required to clean and recalibrate shall be noted.

After successful completion of both fouling tests, a 100 ppm mixture of Arabian light crude oil shall be introduced and any calibration shift noted.

- 3.2.10 The meter will be run on a 500 ppm Arabian light crude oil sample, and the contaminants listed below will be added to the water tank in the concentrations given. Any shift in the meter reading will be noted.

Fresh Water (if sea-water is used for the test programme).

Very Salt Water - 6 per cent common salt with tap water.

Non-soluble suspended solids - about 100 ppm air cleaner test dust
to the following specifications:

<u>Particle size in micrometres</u>	<u>Percentage of total weight</u>
0 - 5	39 ± 2
5 - 10	18 ± 3
10 - 20	16 ± 3
20 - 40	18 ± 3
40 - 80	9 ± 3

3.2.11 The meter will be run on a 100 ppm Arabian light crude oil sample. The high shear pump will be run at various speeds and turned off to provide a range of oil particle size to the meter. Any effect of particle size on the meter reading will be noted.

3.2.12 If the meter is only intended for monitoring bilge water, the oils listed in 3.2.6 and 3.2.7 should be substituted by the oils identified in paragraph 2.2.4 under Part II of these Specifications. The tests indicated in paragraphs 3.2.5; 3.2.6; 3.2.8; 3.2.9; 3.2.10; 3.2.14; 3.2.15; 3.2.16 and 3.2.17 are to be carried out using the heavy fuel oil. Test 3.2.6 should be repeated using the light distillate fuel oil. The oil content used in paragraph 3.2.10 should be 80 ppm and the contaminants should be as listed except that the non-soluble suspended solids should be 20 ppm. The temperature range for the test should be that given in paragraph 2.2.7.

3.2.13 The meter will be run on a 100 ppm Arabian light crude oil sample. Water temperature will be run at 10°C and 65°C. If the vendor's specification lists a maximum temperature less than 65°C, the meter will be run at that maximum temperature and this fact noted.

Any effect of water temperature on meter reading will be noted.

3.2.14 The meter will be run on a 100 ppm Arabian light crude oil sample. Sample pressure or flow will be adjusted from one-half normal, normal and twice normal.

Any effect of these changes on meter reading will be noted.

This test may require modification for meters with flow or pressure regulators or meters designed to discharge into an ambient pressure sump.

The meter will be run on a 100 ppm Arabian light crude oil sample. The water and oil injection pumps will be shut off. No other changes will be made. The meter will be left turned on. After 8 hours, the water and oil will be turned on set at 100 ppm. The before and after readings and any meter damage will be noted. If the meter is fitted with a low flow shut off, this test determines its proper functioning.

3.2.15 The meter will be run on a 100 ppm Arabian light crude oil sample. Supply voltage will be raised to 110 per cent of design for one hour and lowered to 90 per cent of design for one hour. Any effect on meter performance will be noted.

If the meter requires any utilities besides electricity, it shall be tested with these utilities at 110 per cent and 90 per cent of the design figures.

- 3.2.16 The meter will be calibrated and zeroed. A 100 ppm Arabian light crude oil sample will run through the meter for eight hours and any calibration drift noted. Following this, the meter will be run on oil-free water and any zero drift noted.
- 3.2.17 The meter shall be shut down and de-energized for one week. It shall be turned on and started per the manufacturer's instructions. After the suggested warm-up and calibration procedures, the meter will be run one hour on a 100 ppm Arabian light crude oil sample and one hour on oil-free water alternately for eight hours. Any zero or span drift will be noted. The total elapsed time to perform the manufacturer's suggested warm-up and calibration procedures will be noted.
- 3.2.18 For a meter designed only to give an alarm at 15 ppm of oil, the tests detailed in 3.2.5, 3.2.14, 3.2.15, 3.2.16 and 3.2.17 should be performed except that an oil concentration of 15 ppm should be used whenever concentrations up to 100 ppm are specified, and the oil used should be light distillate fuel oil. A calibration curve is not required for such meters, and the response time is to be taken as the time for the meter to give an alarm at 15 ppm oil concentration after the supply to the meter is changed from clean water into oily water having more than 15 ppm of oil.
- 3.2.19 A specification of the instrument concerned and a diagrammatic presentation of the test arrangements should be provided and the following data should be reported in the International Metric System of Units:
- (i) Types and properties of oils used in the tests.
 - (ii) Concentration of oil samples tested.
 - (iii) Details of contaminants tested, and
 - (iv) Results of tests and analysis of samples.

3.3 Installation Requirements

- 3.3.1 The layout of the shipboard installation should be arranged so that the overall response time between an alteration in the mixture being pumped and the alteration in the meter reading should be as short as possible and in any case not more than 40 seconds, to allow for remedial action being taken before the oil content of the mixture being discharged exceeds the permissible limit.
- 3.3.2 The arrangement on board ship for the extraction of samples from the discharge lines to the meter should give a truly representative sample of the effluent. Sampling points should be arranged in all discharge pipes which have to be monitored for compliance with the Convention.
- 3.3.3 Where the Convention requires records, the oil content meters should be so designed and constructed that any operation carried out on them is automatically registered by the meters.

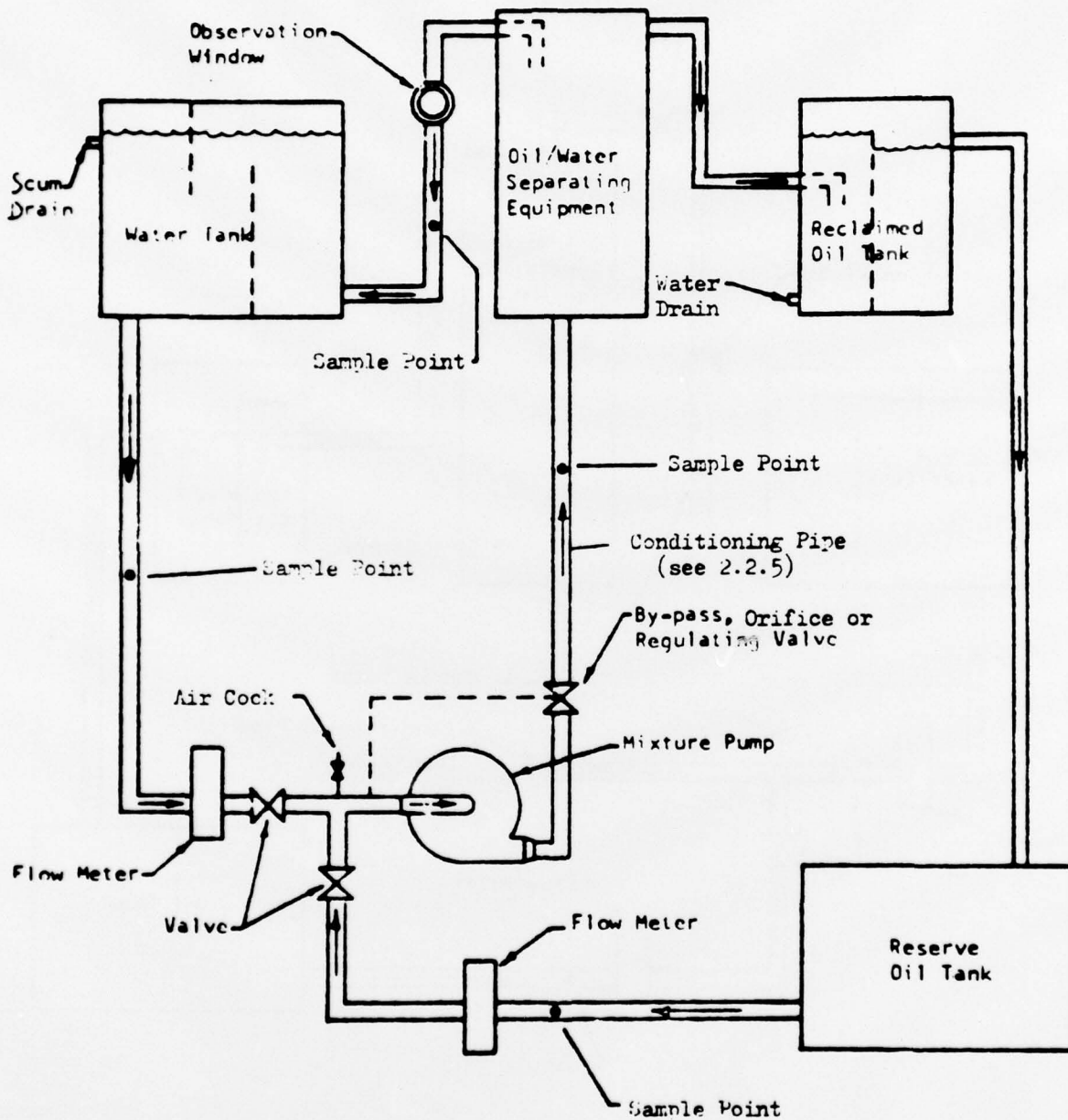

BEST AVAILABLE COPY

Figure 1(a)

BEST AVAILABLE COPY

MEPC VI/17
ANNEX II
Page 26

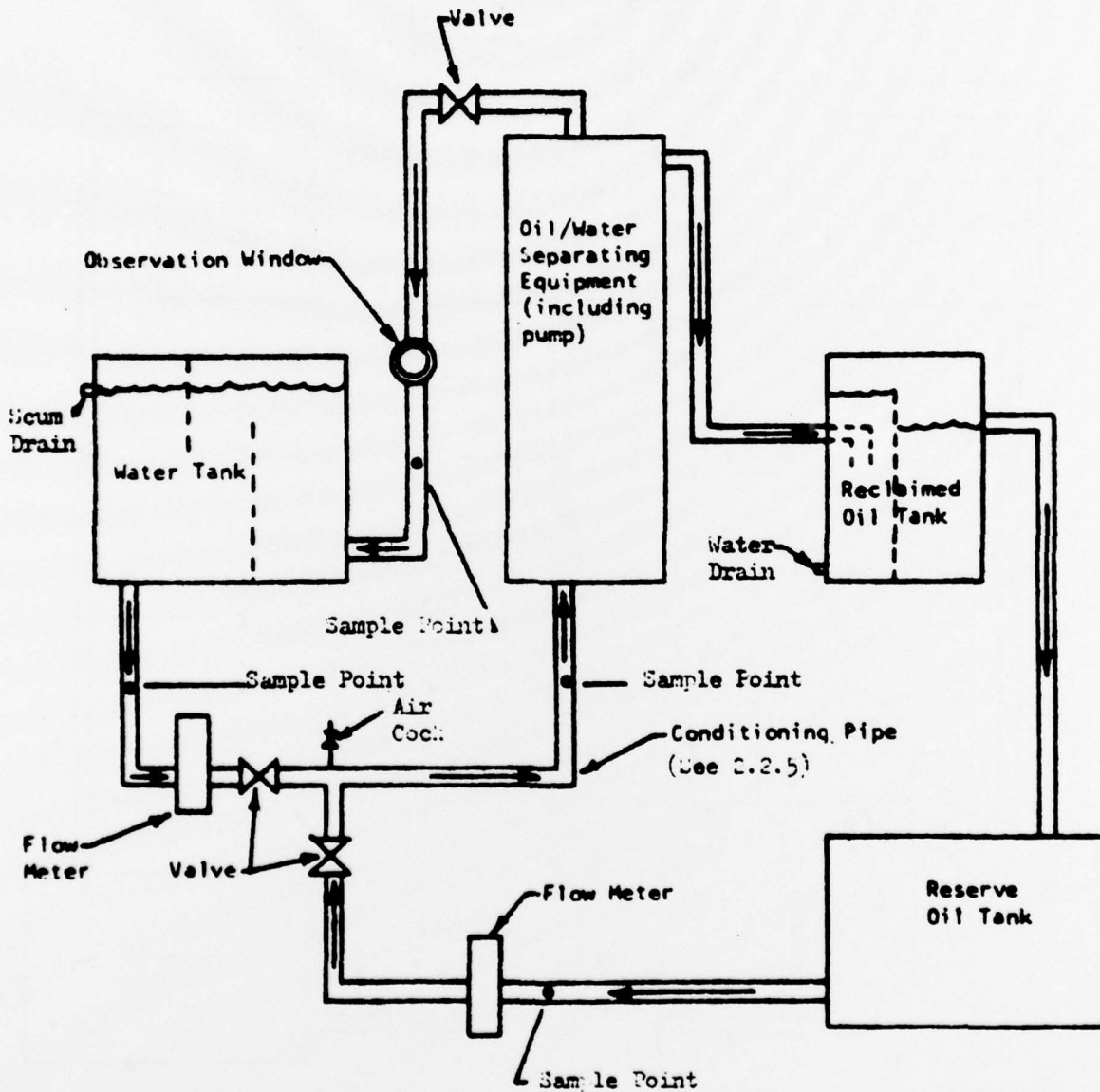
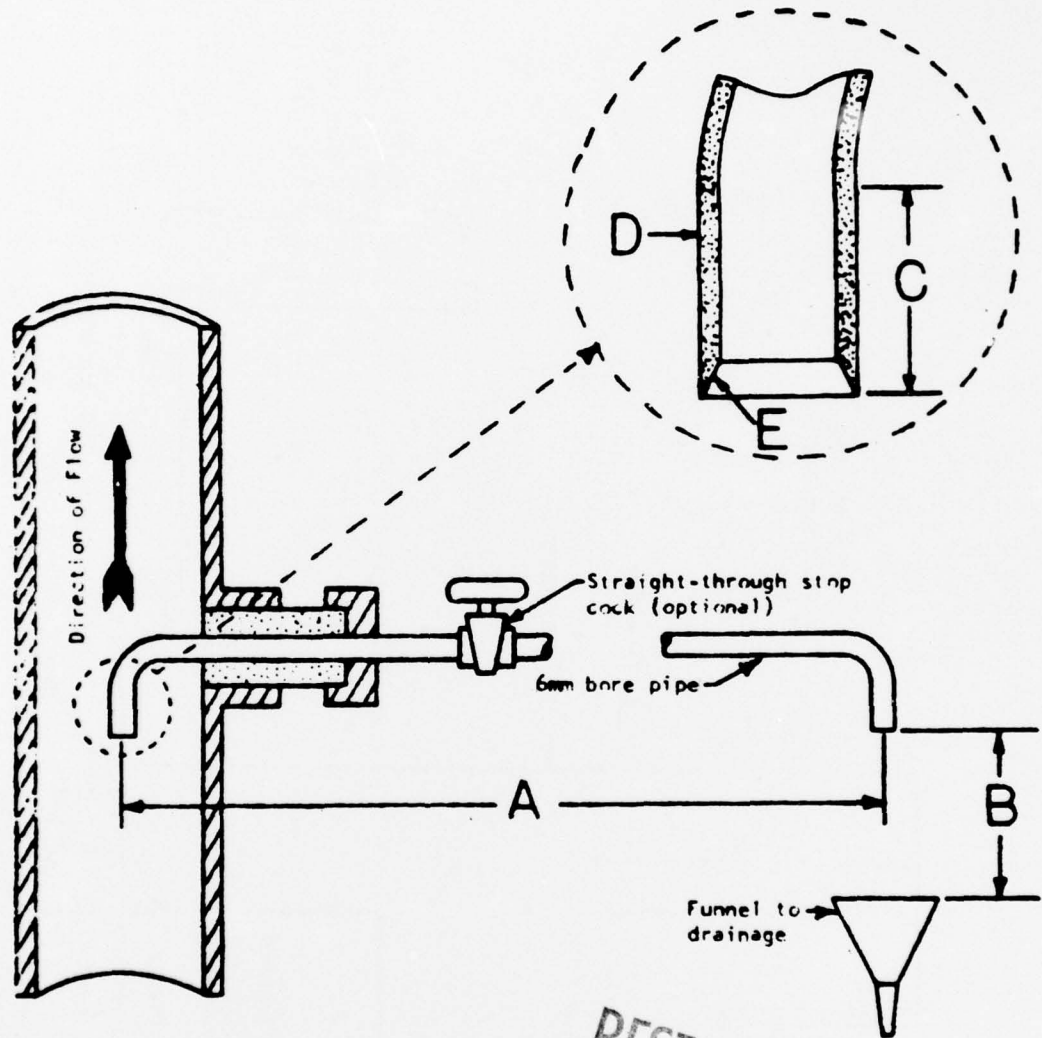

Figure 1(b)



- A** Distance A, not greater than 400mm.
- B** Distance B, sufficient to insert sampling bottle.
- C** Dimension C, straight length should not be less than 60mm.
- D** Dimension D, pipe thickness should not be greater than 2mm.
- E** Detail E, chisel-edged chamfer (30°).

Figure 2.

BEST AVAILABLE COPY

BEST AVAILABLE COPY

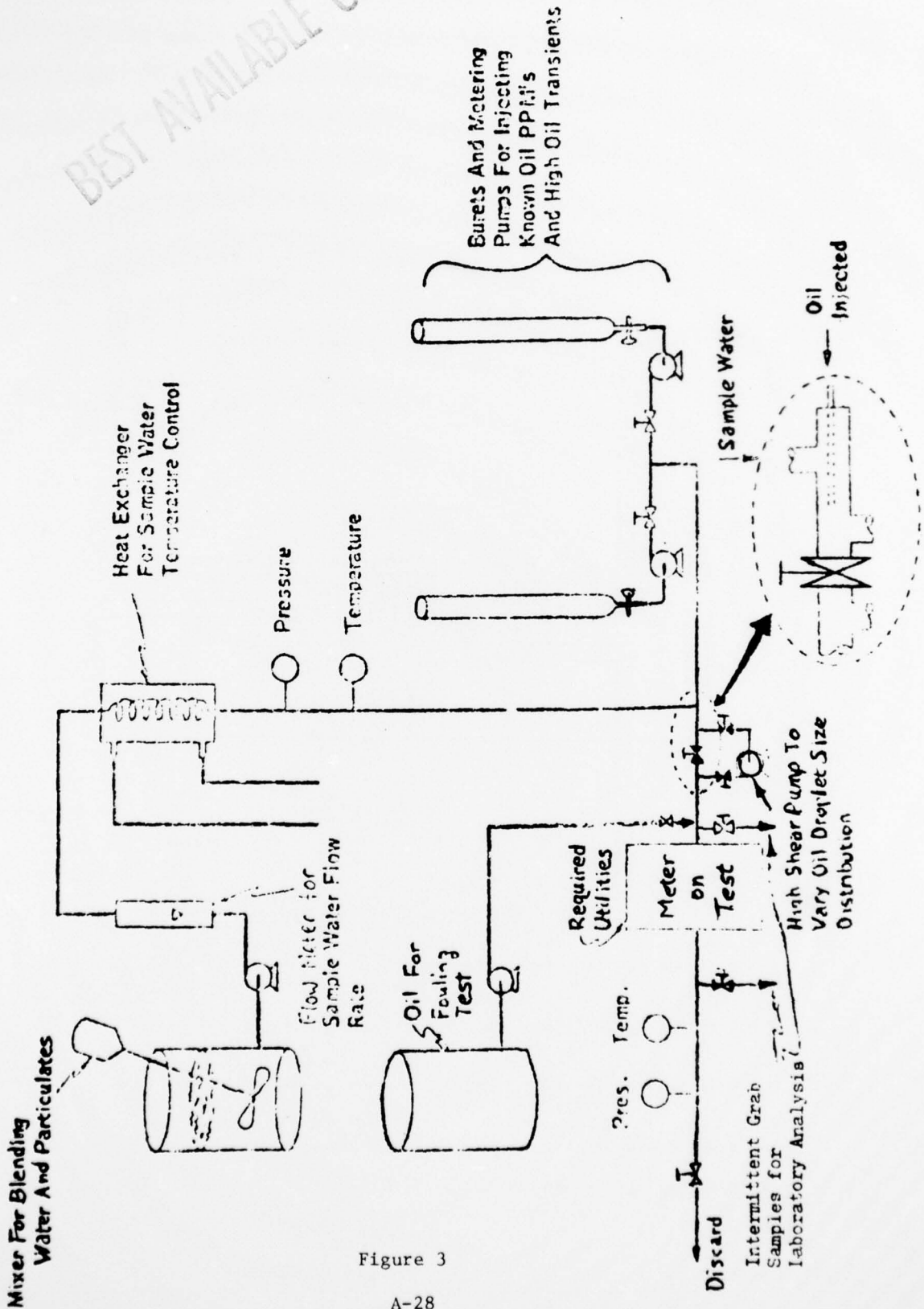

Figure 3

PART IV. METHOD FOR THE DETERMINATION OF OIL CONTENT

4.1 Scope and Application

- 4.1.1 The method includes the measurement of most light oil fractions, although some loss of volatile components will occur during the extractions.
- 4.1.2 The method has a nominal working range from 2 to 80 mg/l. The lower level of detection can be improved to 0.1 mg/l by using longer pathlength cells. The upper limit of the method can be extended at least to 1,000 mg/l by preparing dilutions of the sample extract.

4.2 Summary of Method

The sample is acidified to a low pH and extracted with two volumes of carbon tetrachloride. The oil content is determined by comparison of the infra-red absorbances of the sample extract against known concentrations of the appropriate reference oil. Other suitable non-infra-red active solvents may be used if preferred.

4.3 Sampling and Storage

- 4.3.1 A representative sample of 1 litre volume is collected in a narrow-neck glass bottle with a pressure-sealing cap. Unless the sample will be extracted on the day of collection, it is preserved with the addition of 5 ml hydrochloric acid (HCl) (4.5.1).
- 4.3.2 Because losses of oily matter will occur on sampling equipment, the collection of a composite sample is impractical. Individual portions collected at prescribed time intervals must be analyzed separately to obtain the average concentration over an extended period.

4.4 Apparatus

- 4.4.1 Separatory funnel, 1,000 ml volume, with Teflon stopcock.
- 4.4.2 Infra-red spectrophotometer.
- 4.4.3 Cells, 5 mm pathlength, sodium chloride or infra-red-grade quartz with a minimum of 80% transmittance at 2930 cm^{-1} . The 5 mm pathlength is recommended as being convenient for monitoring levels normally encountered. Longer pathlengths may be used.
- 4.4.4 Filter paper, medium grade, 12.5 cm.

4.5 Reagents

- 4.5.1 Hydrochloric acid, HCl 1:1. Mix equal amounts of conc. HCl and distilled water.
- 4.5.2 Sodium chloride, NaCl reagent grade.
- 4.5.3 Carbon tetrachloride, CCl₄ reagent grade.
- 4.5.4 Oil reference: Oil collected from the source at the same time the sample was collected.
- 4.5.5 Stock reference standard (3 mg/ml): Accurately weigh about 0.30 g of reference oil (4.5.4) into a tared 100 ml volumetric flask and dilute to volume with carbon tetrachloride.
- 4.5.6 Calibration standards: Prepare a series of dilutions by pipetting volumes of stock reference standard into 100 ml volumetric flasks and diluting to volume with carbon tetrachloride. A convenient series of volumes is 5, 10, 15, 20, and 25 ml of stock solution. Calculate the exact concentrations of the dilutions in ng/100 ml solution from the weighing above (4.5.5).

4.6 Extraction

- 4.6.1 If the sample was not acidified at time of collection, add 5 ml hydrochloric acid (4.5.1) to the sample bottle. After mixing the sample, check the pH by touching pH-sensitive paper to the cap to ensure that the pH is 2 or lower. Add more acid if necessary.
- 4.6.2 Pour the sample into a separatory funnel and add 5 g of sodium chloride.
- 4.6.3 Add 50 ml carbon tetrachloride to the sample bottle. Cap tightly and thoroughly shake the bottle to rinse the inside and cap. Transfer the solvent into the separatory funnel and extract by shaking vigorously for 2 minutes. Allow the layers to separate.
- 4.6.4 Drain the solvent layer through a funnel containing solvent-moistened filter paper into a 100 ml volumetric flask.
- 4.6.5 Repeat steps 4.6.3 and 4.6.4 with an additional 50 ml portion of fresh solvent; combine all solvent in the volumetric flask.

- 4.6.6 Rinse the tip of the separatory funnel, filter paper and funnel with small portions of carbon tetrachloride and collect the rinsings in the volumetric flask. Adjust the extract volume up to 100 ml and stopper the flask. Mix well.
- 4.6.7 Drain the water layer into a 1,000 ml graduated cylinder and estimate the sample volume to the nearest 5 ml.

4.7 Infra-red Spectroscopy

- 4.7.1 Prepare the infra-red spectrophotometer according to manufacturer's instructions.
- 4.7.2 Rinse a cell with two volumes of the solution to be measured, then completely fill the cell with solution. Place a matched cell containing carbon tetrachloride in the reference beam.
- 4.7.3 Scan samples and standards from $3,200\text{ cm}^{-1}$ to $2,700\text{ cm}^{-1}$.

NOTE 1: Single beam and non-scanning spectrophotometers can be used for this test. Follow manufacturer's instructions and measure the absorbance directly at or near 2930 cm^{-1} .

- 4.7.4 Construct a straight baseline under the hydrocarbon band as illustrated in Figure 4. If the scan is recorded on absorbance paper, read the absorbance of the peak maximum at 2930 cm^{-1} and subtract the absorbance of the baseline at that point. If the scan is recorded on transmittance paper, the net absorbance is:

$$\log_{10} \frac{\%T(\text{baseline})}{\%T(\text{peak maximum})}$$

- 4.7.5 Prepare a calibration plot of net absorbance vs. ng/100 ml oil using the response of the standards.

NOTE 2: The oil concentration may be plotted as per cent of stock standard. When this procedure is used, the concentration of the stock standard must be used in the calculations (4.8.2).

- 4.7.6 If the net absorbance of a sample exceeds 0.8 or the linear range of the instrument as determined by the calibration plot, prepare a dilution of the sample by pipetting an appropriate volume of the extract into a volumetric flask and diluting to volume. If the

absorbance is less than 0.1, more accurate results can be obtained by using a longer pathlength cell.

4.8. Calculations

4.8.1 Use the calibration plot to calculate the mg of oil in each 100 ml of sample extract or dilution.

4.8.2 Calculate the oil content in the sample using the formula:

$$\text{ng/l oil} = \frac{R \times D \times 1000}{V}$$

where:

R = mg of oil in 100 ml solution
(determined from calibration plot)

D = extract dilution factor, if used (4.7.6)

V = volume of sample, in millilitres (4.6.7)

4.8.3 Report results to two significant figures for levels below 100 ng/l.

NOTE 3: For quality control, a reagent blank should be carried through each step of the procedure.

4.8.4 For purposes of comparison to meter records, the results should also be presented in parts per million (volume/volume) with due allowance for the relative density of the oil.

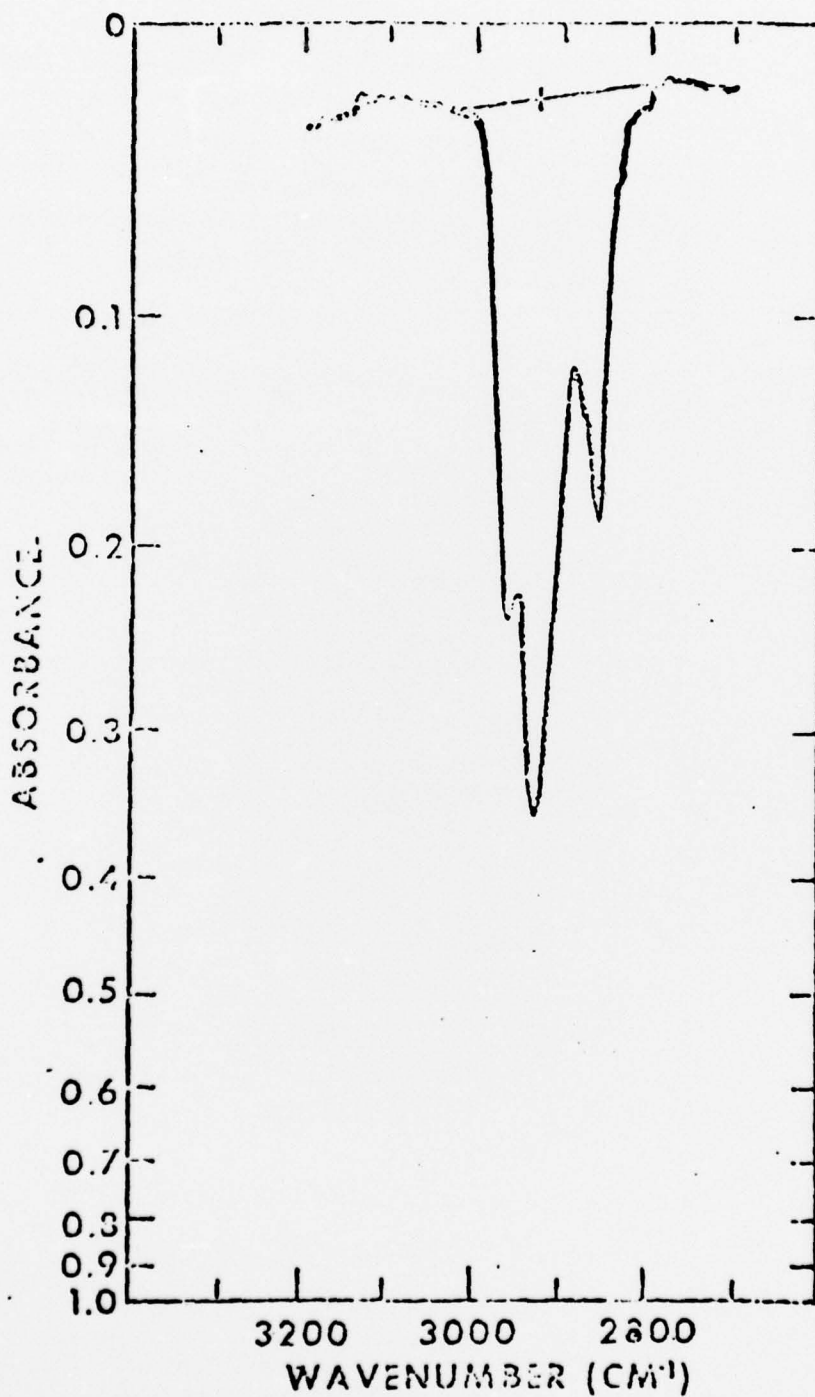

BEST AVAILABLE COPY

Figure 1. Spectrum Illustrating Baseline Construction