

AD-A042 757

UTAH STATE UNIV LOGAN ELECTRO-DYNAMICS LAB F/G 20/6
RADIOMETRIC INSTRUMENTATION AND TECHNIQUES FOR MEASURING INFRAR--ETC(U)
OCT 76 R J HUPPI F19628-74-C-0190
SCIENTIFIC-2 AFGL-TR-76-0253 NL

UNCLASSIFIED

| OF |

ADA042 757



END

DATE

FILMED

9-77

DDC

AD A 042757

AFGL-TR-76-0253

(13)

RADIOMETRIC INSTRUMENTATION AND TECHNIQUES FOR MEASURING
INFRARED EMISSIONS FROM THE ATMOSPHERE AND SPATIALLY
CONCENTRATED SOURCES

Ronald J. Huppi

Electro-Dynamics Laboratories (SRL)
Utah State University
Logan, Utah 84321 and Bedford, Massachusetts 01730

29 October 1976

Approved for public release; distribution unlimited

DDC
AUG 10 1977
HANS COM

This research was sponsored by the Defense Nuclear Agency under Subtask
S99QAXHI004, Work Unit 11, entitled: IR Phenomenology and Optical Code
Development.

AIR FORCE GEOPHYSICS LABORATORY
AIR FORCE SYSTEMS COMMAND
UNITED STATES AIR FORCE
HANSCOM AFB, MASSACHUSETTS 01731

AD NO. _____
DDC FILE COPY

123 870

UNCLASSIFIED

SECURITY CLASSIFICATION OF THIS PAGE (When Data Entered)

REPORT DOCUMENTATION PAGE		READ INSTRUCTIONS BEFORE COMPLETING FORM
1. REPORT NUMBER 18 AFGL-TR-76-0253 (19)	2. GOVT ACCESSION NO.	3. RECIPIENT'S CATALOG NUMBER 14 Scientific-2
4. TITLE (and Subtitle) 6 RADIOMETRIC INSTRUMENTATION AND TECHNIQUES FOR MEASURING INFRARED EMISSIONS FROM THE ATMOSPHERE AND SPATIALLY CONCENTRATED SOURCES		5. TYPE OF REPORT & PERIOD COVERED Scientific Report No. 2
		6. PERFORMING ORG. REPORT NUMBER
7. AUTHOR(s) 10 Ronald J./Huppi		8. CONTRACT OR GRANT NUMBER(s) 15 F19628-74-C-0190
9. PERFORMING ORGANIZATION NAME AND ADDRESS Electro-Dynamics Laboratories (SRL) Utah State University Logan, Utah 84321 and Bedford, MA. 01730		10. PROGRAM ELEMENT, PROJECT, TASK AREA & WORK UNIT NUMBERS P. E. 62704H Proj. S99QAXHI004, W. U. 11 CDNA-00-04
11. CONTROLLING OFFICE NAME AND ADDRESS Air Force Geophysics Laboratory Hanscom AFB, Massachusetts 01731 Monitor/Brian P. Sanford/OPR		12. REPORT DATE 11 29 Oct 1976
14. MONITORING AGENCY NAME & ADDRESS (if different from Controlling Office)		13. NUMBER OF PAGES 32 (1228P)
		15. SECURITY CLASS. (of this report) UNCLASSIFIED
		15a. DECLASSIFICATION/DOWNGRADING SCHEDULE
16. DISTRIBUTION STATEMENT (of this Report) Approved for public release, distribution unlimited.		
17. DISTRIBUTION STATEMENT (of the abstract entered in Block 20, if different from Report)		
18. SUPPLEMENTARY NOTES This research was sponsored by the Defense Nuclear Agency under Subtask S99QAHI004, Work Unit 11 Entitled: IR Phenomenology and Optical Code Development		
19. KEY WORDS (Continue on reverse side if necessary and identify by block number) Radiometer, Spectra, Hydroxyl, Emissions, Atmosphere, and Infrared.		
20. ABSTRACT (Continue on reverse side if necessary and identify by block number) The need to develop very sensitive electro-optical instrumentation for atmospheric studies and defense monitoring systems is of great importance to the understanding of our environment and to the defense of our country. The development of a very versatile, reliable, and sensitive radiometer has provided a tool for performing a variety of significant infrared measurements from ground-based and aircraft platforms in the .8 to 7 μ m spectral region. The development techniques of the radiometer, the capabilities of the developed instrument, and some typical emission measurements are		

D D C
RESOLVED
AUG 10 1977
C

MICROMETERS

123870 JB

UNCLASSIFIED

SECURITY CLASSIFICATION OF THIS PAGE(When Data Entered)

are presented in the paper. The instrument design incorporates various techniques to eliminate the need for cooling of the optics and structural parts, which avoids the inconveniences and difficulties associated with the operation of cryogenically cooled instruments, without significantly sacrificing sensitivity. The radiometer may be used in a selectable spectral wavelength and bandwidth mode, a limited spectral scanning mode, or a tuneable spectral wavelength mode. The various modes of operation are accomplished through the use of interference filters whose spectral characteristics are somewhat adjustable by properly controlling or setting their angular orientation. The simplicity of operation of the instrument has provided a means of measuring atmospheric airglow emissions and aurorally enhanced emissions in the .8 to 1.75 μm region on a routine basis. Also, through the use of a reticle chopper and background suppression technique, the same radiometer has been adapted for measurements of low energy, spatially concentrated emissions in the .8 to 7 μm region.

MICROMETERS

MICROMETERS

TABLE OF CONTENTS

	Page
INTRODUCTION	5
RADIOMETER DESIGN AND CHARACTERISTICS	7
Near Infrared Operation	11
Reticle Chopper Operation	13
Tuneable Spectral Response Operation	16
TYPICAL MEASURED DATA	21
ACKNOWLEDGEMENTS	26
REFERENCES	27
APPENDIX A:	
DISTRIBUTION LIST	28

ADDRESS FOR	
EIS	Write Section <input checked="" type="checkbox"/>
BPP	Dist. Section <input type="checkbox"/>
UNANNOUNCED	<input type="checkbox"/>
CLASSIFICATION	
BY	
DISTRIBUTION/AVAILABILITY CODES	
A	SPECIAL

LIST OF FIGURES

- Figure 1. Four channel radiometer.
- Figure 2. Optical layout of radiometer.
- Figure 3. Block diagram of four channel radiometer electronics.
- Figure 4. Some typical upper atmospheric night airglow emission intensities compared with emissions from a 300^oK blackbody.
- Figure 5. Typical reticle chopper and aperture plate.
- Figure 6. Optical layout of the tuneable filter radiometer.
- Figure 7. Spectral response of the tuneable filter radiometer overlaid on a region of the OH, $\Delta V = 2$ spectrum.
- Figure 8. Pronounced intensity variations of the first overtone hydroxyl (5,3) band apparent zenith emissions over an eight-day period at Poker Flat, Alaska.
- Figure 9. Pronounced intensity variations of the O₂(¹ Δ_g) (0,0) band apparent zenith emissions at 1.27 μ m over an eight-day period at Poker Flat, Alaska.
- Figure 10. Simultaneous zenith intensity variations of apparent emissions from the O₂(¹ Δ_g)0,0 and OH(5,3) bands measured from a KC-135 aircraft flying a north to south profile on March 4, 1976.

LIST OF TABLES

- Table 1. Typical radiometer noise equivalent spectral radiances for near infrared operation with a 10^o field-of-view, a .025 Hz electrical bandwidth, and .05 μ m optical bandwidths.
- Table 2. Summary of possible radiometer measurements using the reticle chopper technique.

INTRODUCTION

The techniques used for the development of infrared electro-optical instrumentation vary significantly from the development techniques used for instrumentation at other wavelengths. When developing a sensitive infrared electro-optical instrument, the effects of thermal emissions from the instrument structure and optics must be considered. Techniques must be developed and used to decrease, suppress, or balance out the thermal emissions to levels which are insignificant compared to the signal emission levels that are to be measured. Also, techniques of suppressing the background around the detector are required to obtain maximum sensitivities from "state-of-the-art" photon limited detectors.

The most obvious way to avoid the thermal emission problems is to cryogenically cool the optics and structures of the instrument with LN₂, LHe, or other coolants. However, in many applications this technique is undesirable, since it adds several complications to the operation of the instrument during measurement programs. For example, at low altitudes frosting problems occur at the optical interface between the instrument and the atmosphere. This problem can be avoided through the use of extensive anti-frost systems, but these systems often require a large dry gas supply in addition to the liquid coolant supplies already being used. These coolant and defrost problems make this type of instrument somewhat difficult to operate in measurement programs which require continual data monitoring over a large number of hours on a regular basis.

To avoid these problems a filtered radiometer which requires only detector cooling was designed and developed. The instrument operates at ambient temperatures and has successfully been used to solve a variety of measurement problems. For example, it has been used to measure upper atmospheric emissions in the .8 to 1.75 μm range.

The same instrument with a slight modification allows measurements of localized sources in extended backgrounds in the .8 to 7 μm spectral range.

The most notable characteristic of the radiometer is its capability to operate very reliably over extended periods of time with a minimum amount of operator attention. It has an optional accessory which allows limited spectral scanning, fixed wavelength tuning, and solar scatter background suppression.

The design layout of the radiometer will be presented and analyzed in this paper. Special emphasis will be placed on the thermal suppression techniques which were incorporated. The characteristics and capabilities of the instrument will be discussed in detail, and examples of typical measurements will be presented.

RADIOMETER DESIGN AND CHARACTERISTICS

A pictorial view of a radiometer which incorporates the design to be discussed is shown in Figure 1. The radiometer has four independent optical and detector channels integrated into one package. The instrument uses a common optical chopper and a common filter wheel which minimize the physical size of the unit. Other similar units incorporating one or two independent optical channels have also been designed. In all cases the optical layout is essentially the same. The optical layout for each channel is represented in Figure 2.

The basic lens system consists of a 2-inch diameter, $f/2.5$ objective lens followed by a 1-inch diameter $f/.7$ field lens. In addition, the detector is often immersed on a third lens of hemispherical shape to minimize the required detector size. In the layout the objective lens images points at infinity on the aperture plane which defines the field of view of the radiometer. Since the objective lens is relatively slow, its imaging properties can be made extremely good to guarantee a sharply defined field-of-view. However, the field lens does not require these same sharp imaging qualities, since its function is to collect the optical signal passing through the aperture and condense it onto a detector. As a result, the field lens can be made relatively fast which minimizes the required detector size and maintains a low equivalent f number for the optical system.

As shown in Figure 2, the radiometer design incorporates an optical chopper to modulate the signal. The chopper is located within .025 inches of the aperture plane. The standard chopper modulates the complete aperture on a fifty percent duty cycle basis; however, coded or reticle type choppers can be used to encode the focal field or define the aperture. These coded choppers can extend the capabilities of the instrument by spatially encoding the signal and by suppressing background and instrument emissions.

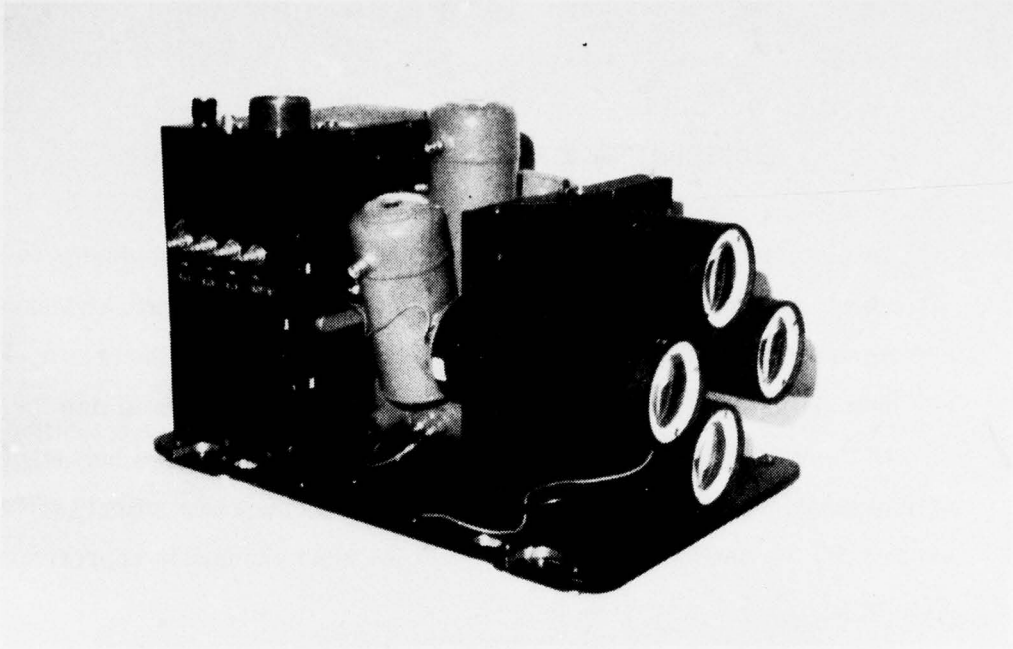

Figure 1. Four channel radiometer.

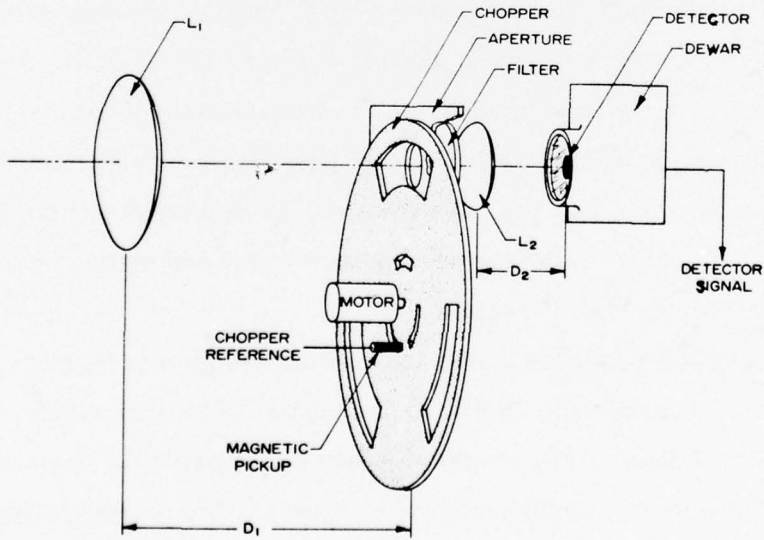

Figure 2. Optical layout of radiometer.

After the modulation is performed, the signal is spectral-band limited by an optical interference filter. This filter defines the spectral response of the instrument and limits the modulated thermal emissions that reach the detector from the instrument structures. Typically, a rotatable filter wheel is used to locate the filter, which allows some wavelength selection through filter changes.

Once the optical signal has been filtered, it is collected onto a detector and is ready for processing. The processing usually involves a standard synchronous demodulation technique using lock-in amplifiers. A typical layout of the processing method for a four channel unit is shown in Figure 3. The processing technique provides a real time output voltage whose amplitude is proportional to the modulated optical energy reaching the detector. It is important to note that unmodulated energy is not detected, since the synchronous demodulator circuits only recognize signals that are referenced to the chopper. Therefore, the only instrument thermal emissions that affect the signal levels are those which are spectrally limited to emissions within the optical bandpass of the filter, since the filter and aperture are located after the chopper. However, the effects of the thermal emissions from the warm instrument within the passband must still be considered. For many cases in the near infrared region, these emissions are insignificant. At longer wavelengths they become more significant, and background balance techniques are required to extend the usefulness of the instrument. In the following two sections, consideration of these band limited thermal effects will be discussed for some practical modes of operation of the radiometer. In addition, consideration will be given to how the total thermal background affects the detector's sensitivity, since even the unmodulated thermal background can increase the noise of a photon limited detector.

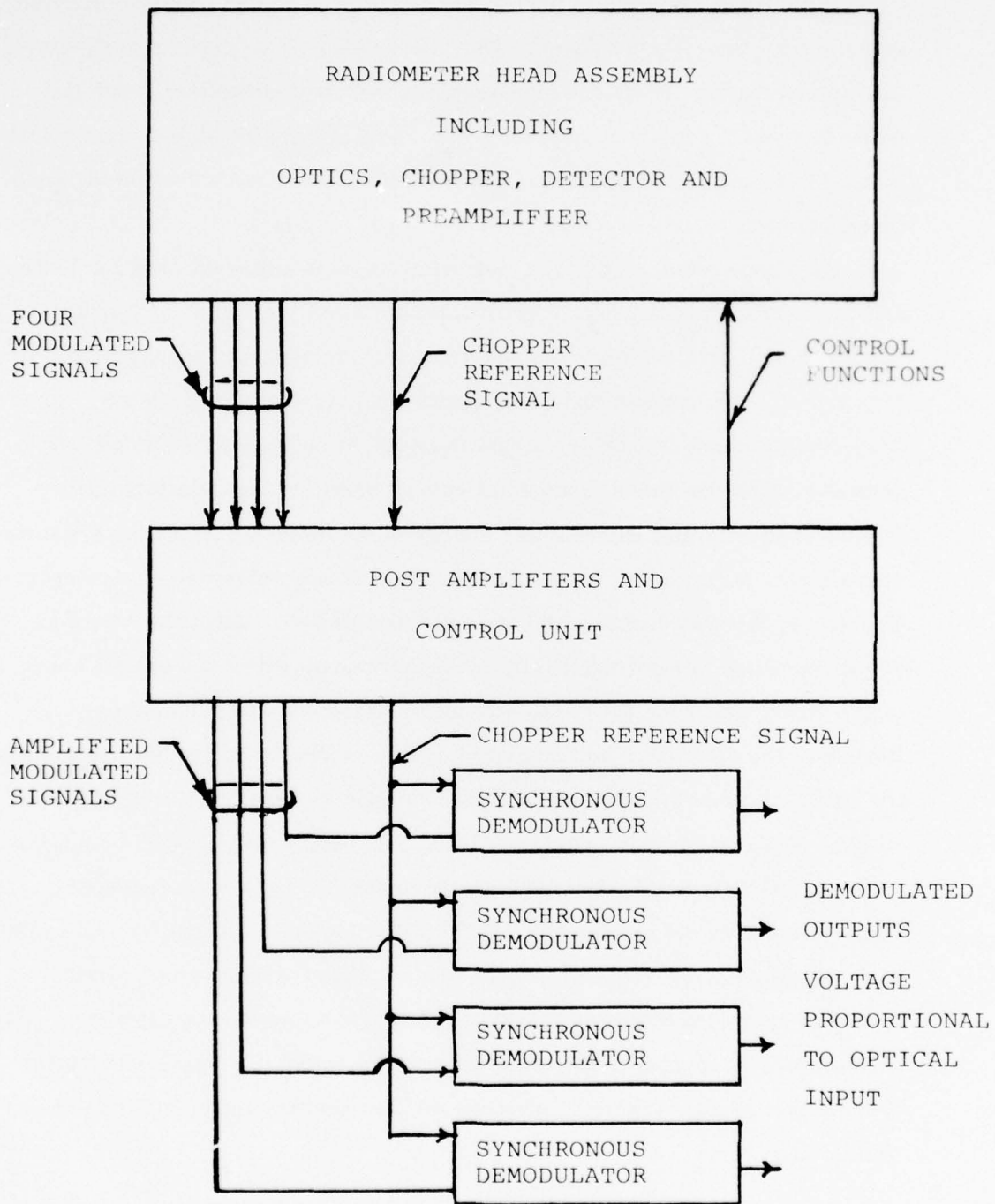

Figure 3. Block diagram of four channel radiometer electronics.

Near Infrared Operation

One important use of the radiometer is for the measurement of upper atmospheric emissions in the .8 μm to 1.75 μm region. In this spectral region the thermal emissions of the instrument are small compared to typical emission levels of night airglow. This is apparent from Figure 4, which shows the thermal emission intensities of a 300^oK blackbody and some typical intensities of the atmospheric night airglow emissions over the spectral wavelength region. The presented blackbody emissions, as calculated by Planck's law, should represent worst-case instrument emission intensities. The presented atmospheric emission levels are typical of the night sky emission intensities that have been measured by AFGL, USU, and others.^{1,2,3,4} As shown in Figure 4, the worst-case instrument emissions are several orders of magnitude below the expected night airglow emissions of the O₂(¹ Δ_g) band at 1.27 μm and part of the first overtone OH band. As a result, instrument emissions in this region should have an insignificant effect upon measurements of the night airglow. However, at longer wavelengths the thermal emissions from the instrument approach the expected atmospheric emission levels. At 1.75 μm the thermal emissions are still about an order of magnitude below the night sky, but beyond about 1.85 μm the instrument emissions begin to dominate and must be blocked or rejected.

The radiometer in Figure 2 can use the optical filter to reject detectable emissions from the instrument beyond 1.75 μm . Various bandpass filters can be used to limit the measurement region to narrow bands within the .8 to 1.75 μm region, but it is extremely important that the filter also adequately block the longer wavelength thermal emissions of the instrument structure. This blocking must be complete and extend to the long wavelength cut-off of the detector being used.

The blocking problem is readily solvable when an intrinsic germanium detector is used, since the typical detector cut-off occurs at about 1.7 μm . Other types of detectors present more of a problem however. Cooled PbS detectors with a

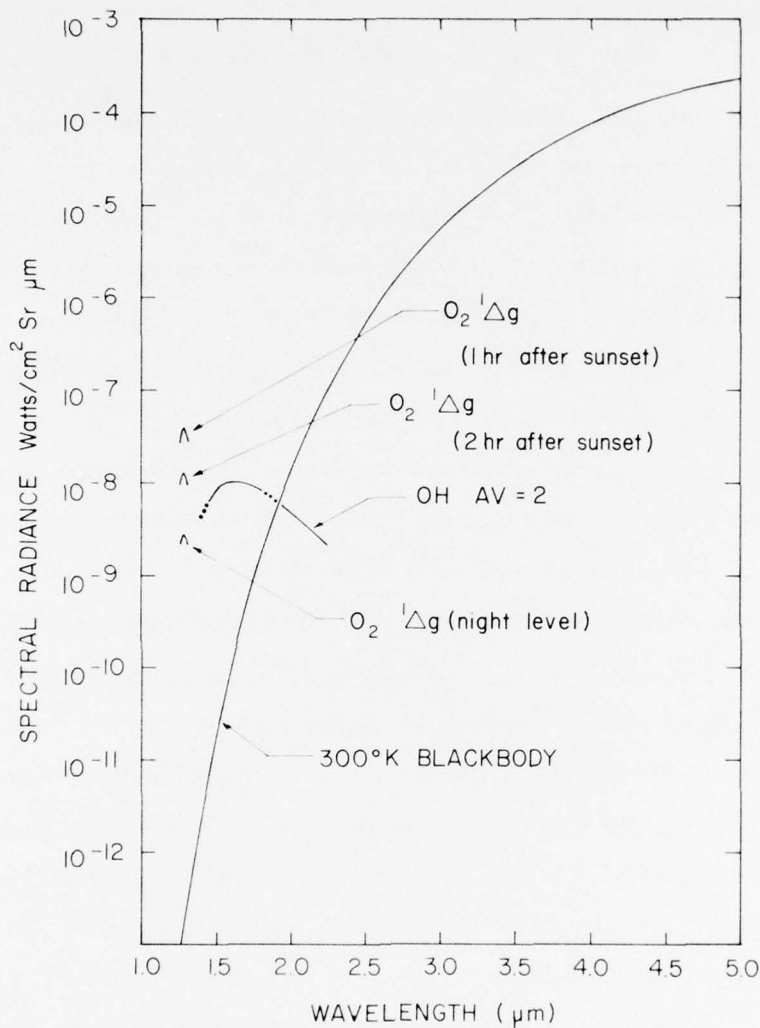

Figure 4. Some typical upper atmospheric night airglow emission intensities compared with emissions from a 300°K blackbody.

3 μm cut-off require about five orders of blocking to adequately block the instrument emissions. InSb detectors require even better blocking. They require about seven orders of rejection, since their response extends to longer wavelengths where the thermal emission intensities become much larger. For the near infrared measurements described, the radiometer is typically assembled with thermoelectrically cooled PbS or liquid nitrogen cooled germanium detectors.

As a result, filters with adequate blocking have been readily obtainable from some of the better filter manufacturers.

Typical noise equivalent spectral radiances (NESR's) of the radiometer for three types of detectors are shown in Table 1. To obtain the low NESR's given, special attention must be given to the detector selection and detector operation. The detector temperature must be optimum, and cold shielding and cold filtering must be used to minimize the photon noise from the warm background. This is especially important for the InSb detector, since it responds to longer wavelengths where the background energy gets large.

From the table it is apparent that the instrument is sufficiently sensitive to measure the typical airglow emissions shown in Figure 4. The instrument has been very successfully used for these types of measurements from the ground and from an aircraft, and some typical results are presented in the measurement section of this report.

Table 1. Typical radiometer noise equivalent spectral radiances for near infrared operation with a 10° field-of-view, a .025 Hz electrical bandwidth, and .05 μm optical bandwidths.					
Detector Type	Detector Cooling	Detector Temperature	Detector D^* $\text{cm Hz}^{\frac{1}{2}}/\text{w}$	Wavelength μm	NESR $\text{w}/\text{cm}^2 \text{sr } \mu\text{m}$
PbS	Thermo-electric	-60°C	3×10^{11}	1.7	9.3×10^{-12}
InSb (Cold Filtered)	LN_2	77°K	3×10^{12}	1.7	9.3×10^{-13}
Ge	LN_2	77°K	7×10^{13}	1.45	4.0×10^{-14}

Reticle Chopper Operation

The radiometer has also been extremely useful for measurements of localized emission sources in extended backgrounds at wavelengths as long as 7 μm . To accomplish this the aperture and chopper of the radiometer are

modified to a reticle system. The reticle system is designed to balance out the instrument thermal emissions and also bright uniform backgrounds. However, spatially small infrared sources are not balanced out, and they are detectable with the radiometer.

A typical reticle chopper and aperture is shown in Figure 5. These parts

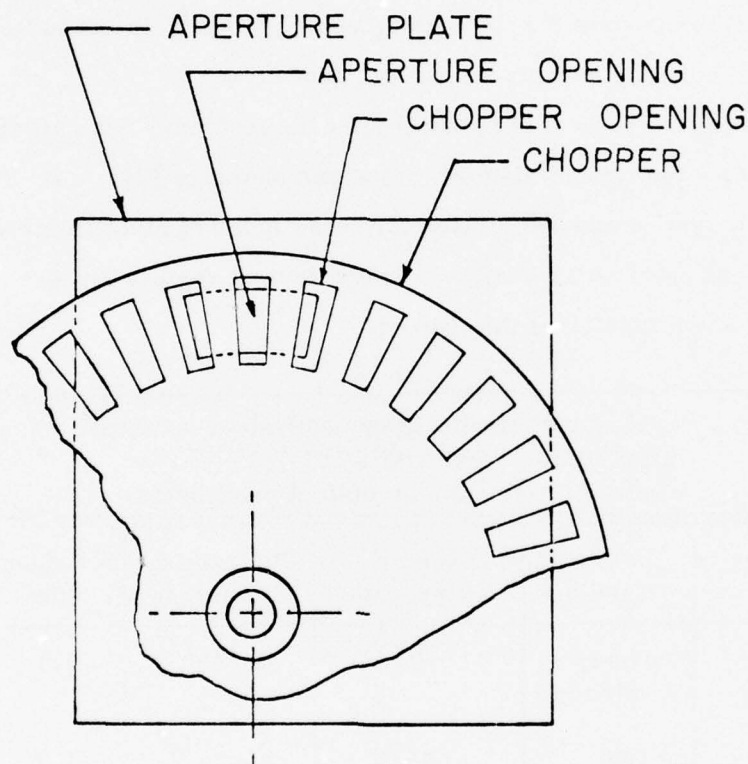

Figure 5. Typical reticle chopper and aperture plate.

replace the chopper and aperture shown in the optical layout presented in Figure 2. They are placed at the focal plane of the objective lens, and the spacing between the chopper and aperture is kept to a minimum. As discussed previously, the objective lens of the radiometer images distant sources on the aperture plane. The radiant flux which passes through the aperture opening is condensed and uniformly distributed over the detector. This is accomplished by the field lens since it images the objective lens onto the detector. As shown

in Figure 5, the chopper is constructed such that an equal and a constant amount of the aperture area is blocked and open at all times while the chopper is rotating. As a result, uniform radiation sources which fill the field aperture opening are unmodulated when they reach the detector. Emissions reaching the detector from the chopper blade and instrument are also unmodulated, since they are also uniform and fill a constant area of the aperture at all times. However, a source will be completely modulated upon reaching the detector if its image size in the focal plane of the objective lens is smaller than the size of the opening formed by one chopper blade opening and the aperture opening. These modulated signals are the only ones that are detectable with the radiometer, since the detector signals are synchronously demodulated with a vector phase-lock amplifier which extracts only modulated signals that are referenced to the chopper. These characteristics make the instrument very useful for the measurement of spatially small infrared sources in a bright background.

The radiometer operating in this mode has some practical limitations however. In addition to the usual limitations of the detector's sensitivity and the qualities of the optical components, there are practical limitations as to what extent the reticle scheme can suppress or balance out the thermal emissions of the instrument and the extended bright backgrounds. If a reticle, as shown in Figure 5, is carefully constructed and optically balanced, one can obtain as much as four orders of background suppression. With this suppression, the uncooled instrument is capable of measuring sources having spectral radiances as small as 10^{-8} watts/cm²-sr- μ m in the 4 to 5 μ m range. At shorter wavelengths even lower intensity sources can be measured, while at longer wavelengths the instrument is more limited because of the increased instrument thermal emissions. More sophisticated reticles can be designed to further extend the usefulness of the instrument. For example, a coded reticle chopper can be used to spatially encode the image of a source. One possible encoder might consist of several sets of Hadamard encoded slots or masks positioned on concentric circles to form the chopper blade. As the blade rotates across the image at the aperture, the intensity as a function of position is encoded. Then by properly decoding the signals from the detector, spatial resolution of the

source intensities is obtained. To fully understand this technique a thorough discussion would be necessary, and it will not be presented in this paper. However, it is worth noting that the basic radiometer being discussed can readily incorporate these types of techniques.

Tuneable Spectral Response Operation

For many measurement programs it is desirable to shift, or tune, the central wavelength of a spectral bandpass radiometer during operation. This is often accomplished through the use of a circular variable filter (CVF) which allows continuous wavelength scanning or wavelength tuning of a radiometer over a large spectral region. Practical instruments incorporating CVF's have been successfully designed for AFGL by USU.⁵ However, CVF's are often very expensive, and their minimum spectral bandwidth is presently limited to about 2 or 3% of the center wavelength. Also, many measurement applications only require wavelength tuning or scanning over a limited spectral region. For these applications another approach, which is commonly used in visible photometer designs, can be readily extended for use in the infrared radiometer being discussed.

The technique involves tilting an optical filter to produce wavelength shifts. Figure 6 shows a modified optical layout of the radiometer which incorporates a tuneable filter. In this configuration, the tuneable filter defines the spectral response of the radiometer. The optical filter behind the chopper is used only to limit the modulated thermal emissions of the instrument which reach the detector. This blocking filter usually consists of a wide bandpass or shortpass filter, and it must be selected to sufficiently block the instrument thermal emissions without affecting the spectral region being scanned by the tuneable filter.

It is important to locate the tuneable filter before the objective lens, since the angular variation of the radiation collected by the radiometer is minimal at this location. Spectral scanning or spectral wavelength tuning is accomplished simply by changing the filter's angular orientation with respect to the optical

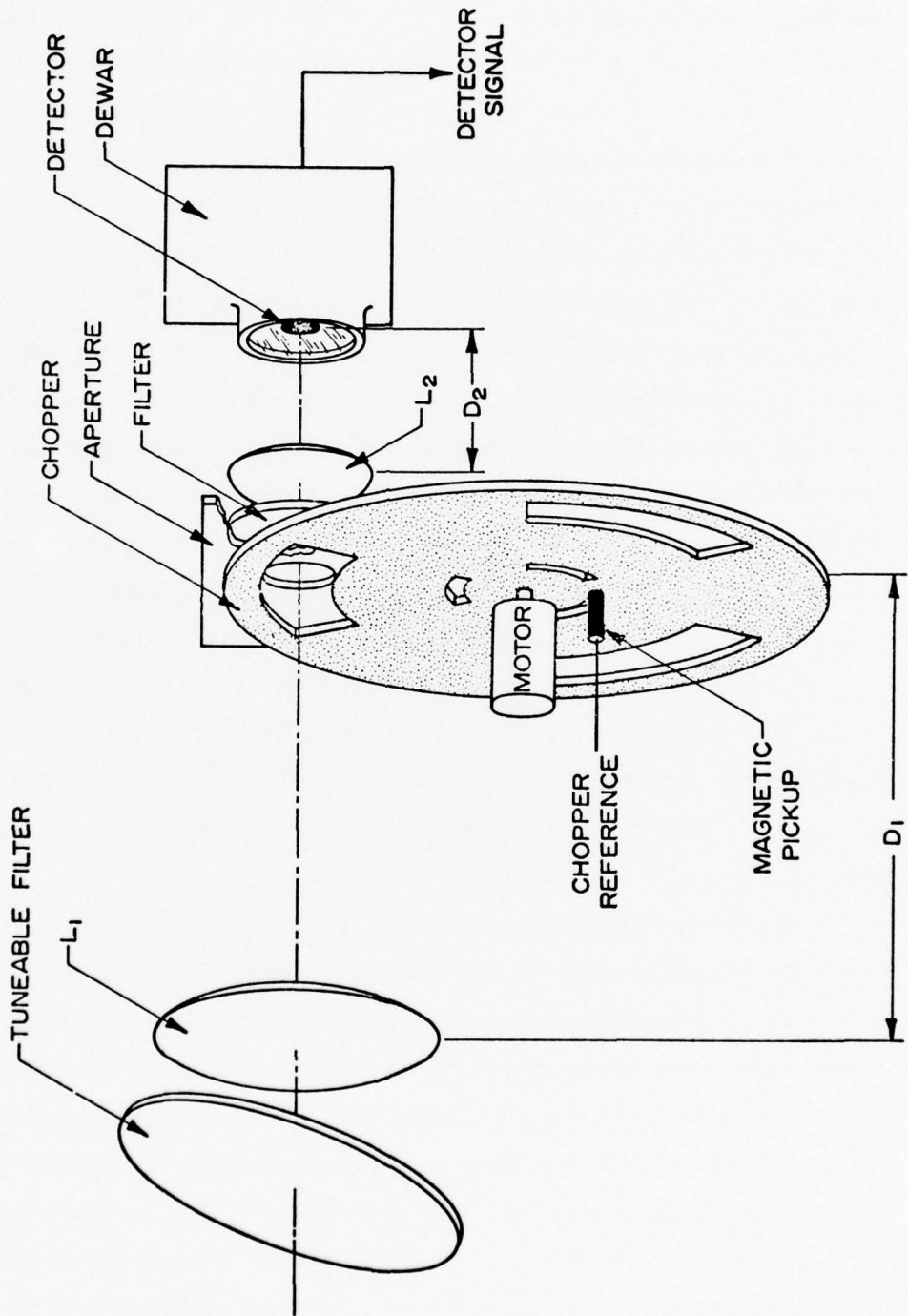

Figure 6. Optical layout of the tuneable filter radiometer.

axis. Many filters can be successfully tilted to a maximum of 35° without drastically affecting their transmission and bandwidth characteristics. The wavelength shift obtainable is dependent on the filter construction, but shifts as large as 10% of the center wavelength have been successfully obtained.

The use of this technique has been applied to measurements of the upper atmospheric hydroxyl emissions. Figure 7 shows the spectral response curves of the radiometer at various filter angles. The response curves are overlaid on a typical spectrum of the hydroxyl first overtone region as measured by a wide field of view interferometer designed by USU and AFGL.⁶ If the filter is continuously rocked from 0° to 18° , the radiometer will scan from a wavelength corresponding to 5900 cm^{-1} to a wavelength corresponding to 6000 cm^{-1} with a spectral resolution of about 50 cm^{-1} . The scanned region can be increased to include wavenumbers up to about 6200 cm^{-1} by increasing the angular scan of the filter to a maximum angle of 30° . Also, the radiometer can be tuned to selectable fixed wavelengths within the spectral scan region by selecting the proper filter angles with a programmable stepping device.

As shown in Figure 7, the spectral resolution of the tuneable radiometer is not good enough to resolve all the spectral lines of the OH emissions. However, the resolution is good enough to resolve regions of intense emissions, like those of 5995 cm^{-1} , from regions where the emissions are minimal, like those at 5950 cm^{-1} and 6030 cm^{-1} .

This limited resolution capability can be very useful in the measurement of the OH emissions from the ground during twilight conditions, since it provides a means of distinguishing between the solar scatter and the true OH emissions. The twilight measurement can be further improved by incorporating a polarization filter in addition to the already existing filters. The polarization filter is used to reject the large polarized portion of the solar scatter which exists during twilight conditions. Using both of these techniques, the OH emissions can be successfully measured from the ground at solar depression angles as small as 3° . This essentially gives a dayglow measurement of the OH emissions, since at 3° depression angle the sun is still shining on the 80 km altitude region where the generation of the OH emissions typically occurs.

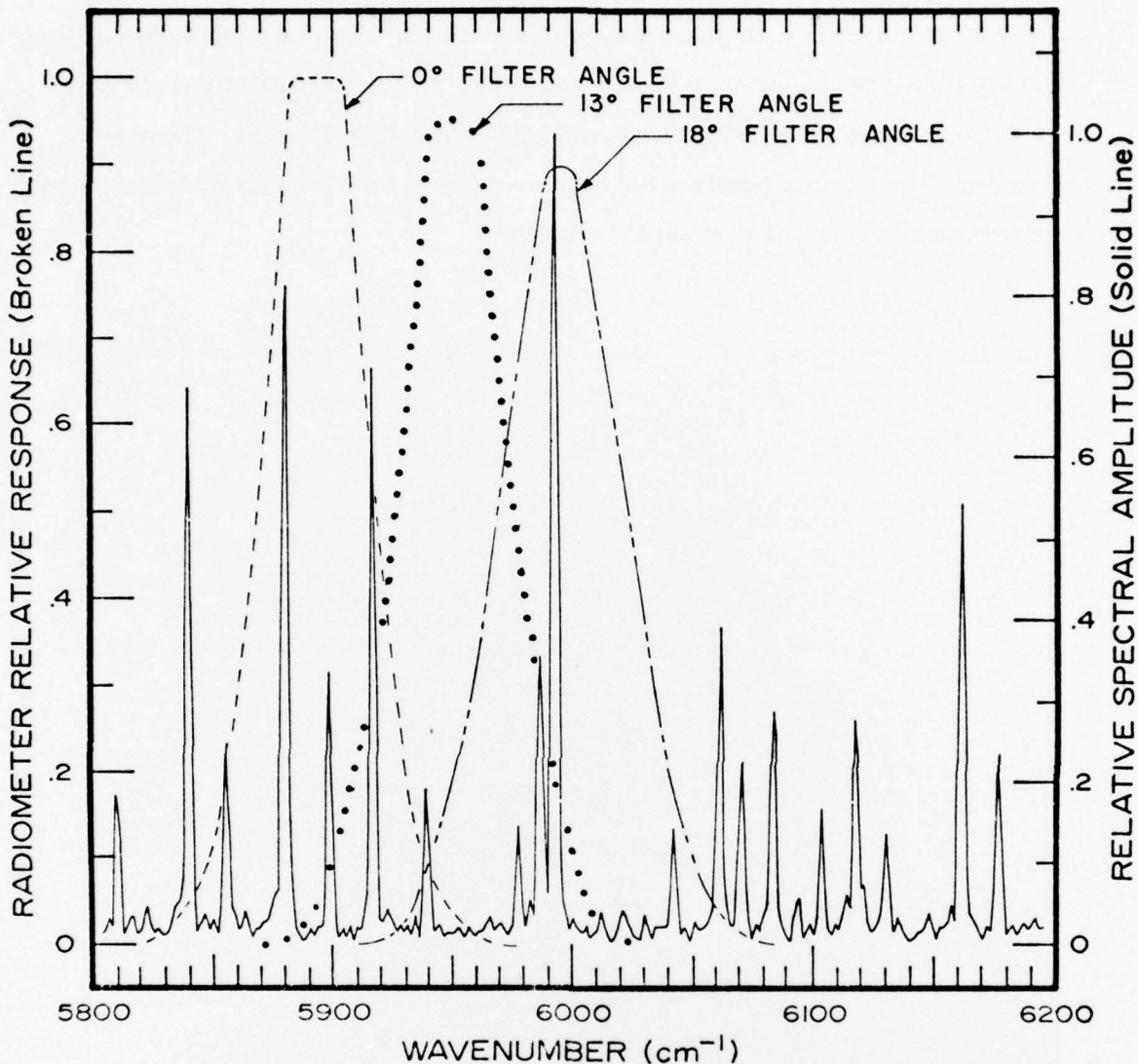

Figure 7. Spectral response of the tuneable filter radiometer overlaid on a region of the OH, $\Delta V = 2$ spectrum.

The tuneable filter radiometer can also be used to advantage in many other practical measurement applications, but its uses are somewhat limited by its spectral resolution. Therefore, the radiometer's capabilities could be greatly improved by incorporating a filter with a narrower bandwidth. This is possible with present-day technology, but it is often costly. The filter used to define the radiometer response shown in Figure 7 cost only \$500, providing a successful test of the technique without a large investment. Several companies have indicated

that similar filters with bandwidths of about 15 cm^{-1} can be manufactured using Fabry-Perot techniques. In fact, Perkin-Elmer has successfully made solid Fabry-Perot infrared filters with bandwidths less than 1 cm^{-1} . These very narrow filters are expensive, but they would be a very worthwhile improvement when greater spectral resolution is needed.

TYPICAL MEASURED DATA

The high reliability, excellent stability, and operational simplicity of the radiometer have made possible the cataloging of large amounts of data which have been collected over a period of eight years. The catalog includes measurements of various upper atmospheric emissions and measurements of various infrared sources with limited spatial size.

The most extensive measurements taken have been of emissions from excited hydroxyl molecules in the upper atmosphere. The most widely accepted photo-chemical reactions adopted to explain the origin of these hydroxyl airglow emissions are

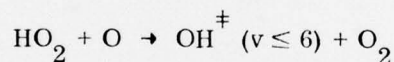
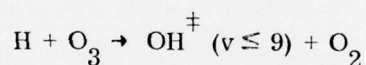

To date, however, there are still substantial uncertainties concerning the specific processes which govern the OH emissions. These uncertainties result from observed intensity variations which are not fully explainable. To provide inputs to these unknowns, the radiometer discussed in this paper has been used to measure hydroxyl intensity variations of all types over the past 8 years.¹ The measurements include diurnal variations, day-to-day variations, spatial variations, and variations associated with auroras. An example of one significant intensity variation is given in Figure 8, which shows intensity variations of the first overtone OH (5,3) emissions as large as a factor of 5 over an eight-day period. This particular variation is very pronounced, whereas many others are less apparent.

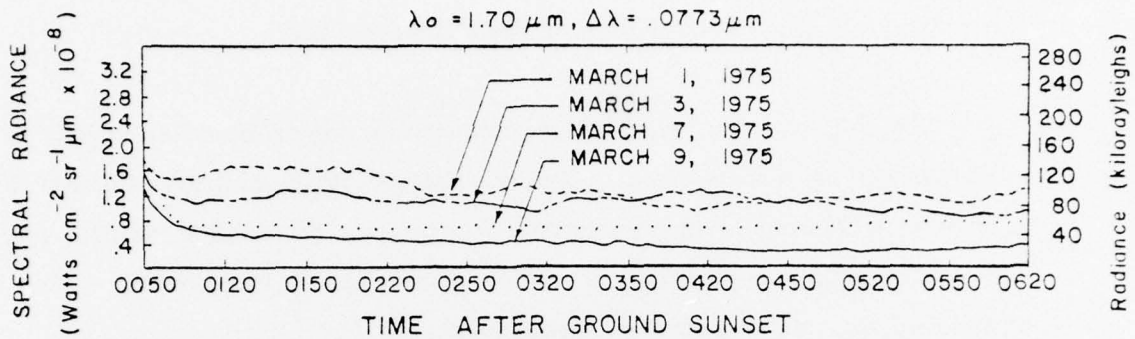

Figure 8. Pronounced intensity variations of the first overtone hydroxyl (5,3) band apparent zenith emissions over an eight-day period at Poker Flat, Alaska.

Measurements similar to those of the OH emissions have also been made of the $\text{O}_2(^1\Delta_g) 0,0$ band emissions at $1.27 \mu\text{m}$. An example of the $\text{O}_2(^1\Delta_g)$ measurements is given in Figure 9. As shown, the magnitude of the variations is very similar to that of the OH for the same 8 day period. In addition, it should be noted that the long decay rate from the daytime to nighttime levels of the O_2 emission is also measured.

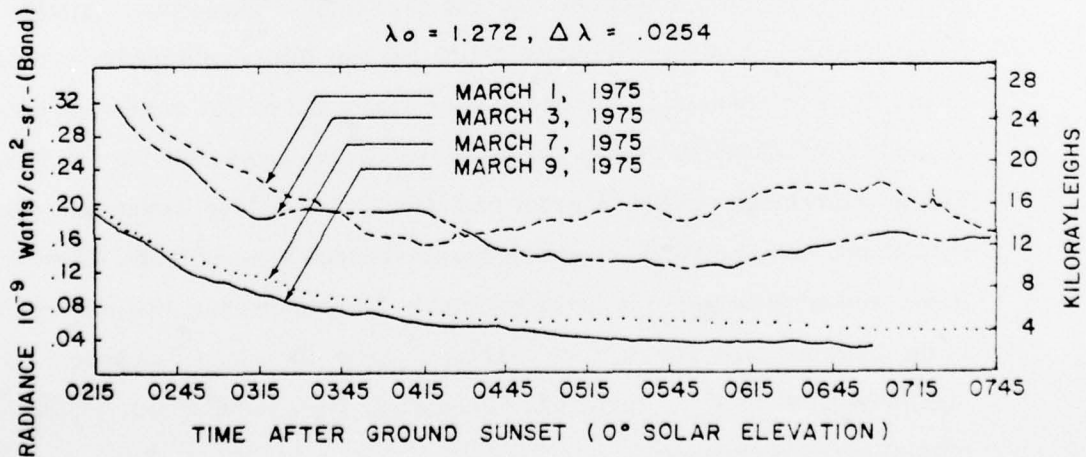

Figure 9. Pronounced intensity variations of the $\text{O}_2(^1\Delta_g) (0,0)$ band apparent zenith emissions at $1.27 \mu\text{m}$ over an eight-day period at Poker Flat, Alaska.

Typically, the OH and O₂ emissions are measured simultaneously. This is easily accomplished since the radiometer can be constructed to have up to four independent channels that can operate continuously. The simultaneous measurement allows correlation studies to be made between the two emissions. A visible photometer is also operated to increase the understanding of the correlated information. Figure 10 shows some interesting data collected for one of these studies. As shown, an apparent enhancement was observed in the O₂ emission but not in the OH emission. This enhancement appeared to be a spatially related phenomenon, since the measurement was made from an aircraft flying a north-to-south profile. In order to sufficiently analyze enhancements such as this, a large catalog of similar measurements may be needed. However, this presents no problem to the radiometer, since it can operate day after day over long time periods without interruption.

The specific measurements discussed thus far mainly incorporate the techniques explained in the Near Infrared Operation section. However, as discussed previously, the instrument can be used for a variety of measurements at longer wavelengths by incorporating a reticle chopper. Many of the measurements made in this manner are classified and therefore will not be specifically presented in this paper. Instead, a brief description of specific types of measurements that can be measured with the instrument is given in Table 2. This table should provide an understanding of the overall capabilities of the instrument operating in the reticle mode.

All of the data discussed in this paper are presented only to give the reader a better idea of the uses and capabilities of the radiometer. The presented data are not intended to be complete or sufficiently analyzed to be of scientific significance. If there is further interest in specific data, many of the articles referenced throughout the paper should be of interest.

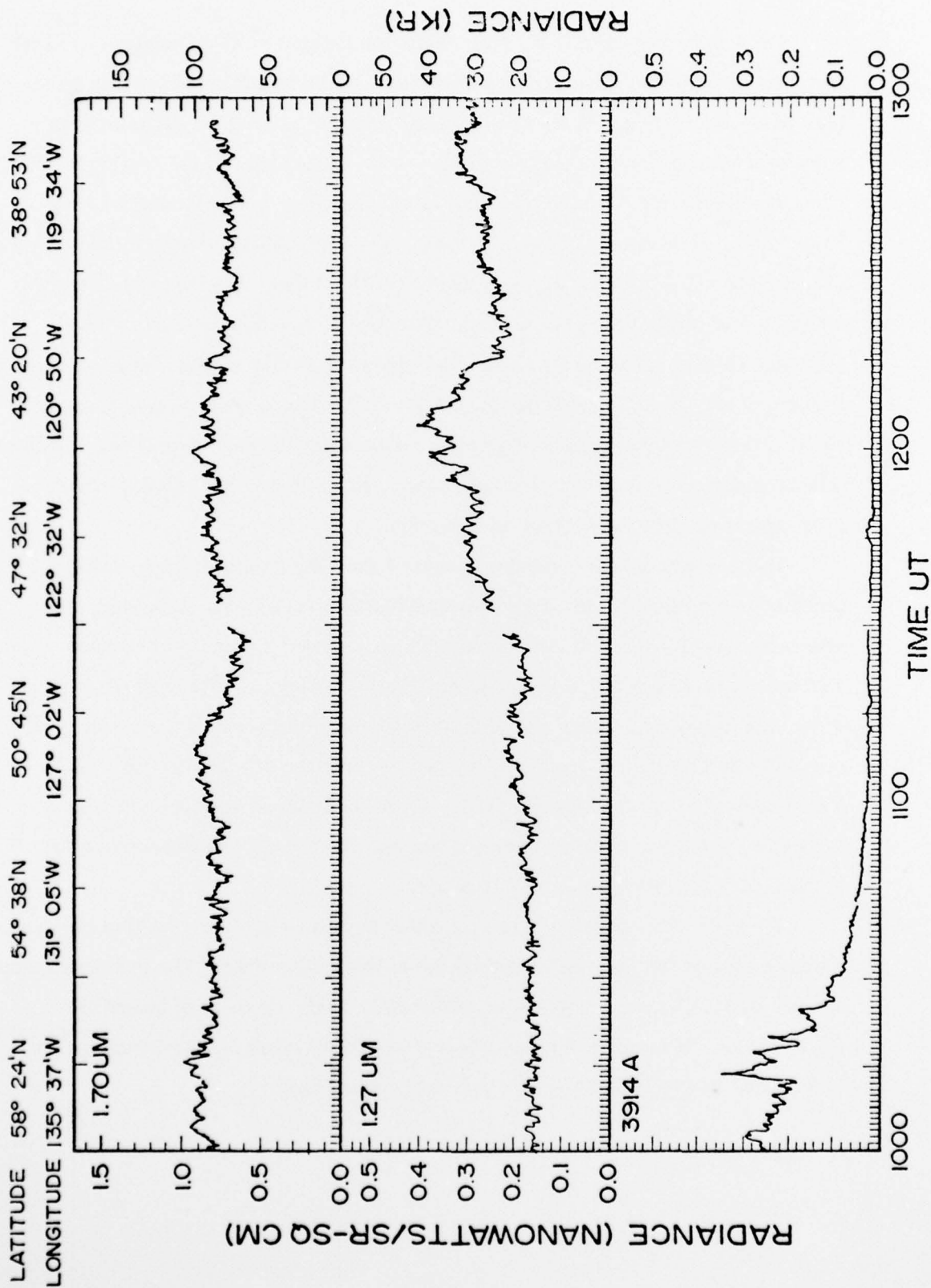

Figure 10. Simultaneous zenith intensity variations of apparent emissions from the $O_2(^1\Delta_g)0,0$ and $OH(5,3)$ bands measured from a KC-135 aircraft flying a north to south profile on March 4, 1976.

Table 2. Summary of possible radiometer measurements using the reticle chopper technique.

Source	Maximum Wavelength Measured	Type of Measurement
Clouds (Isolated patch in a sky or earth background)	7 μm	Absolute intensity of emitted or reflected IR signal.
Burning Flame (Propane torch)	7 μm	Time history of absolute emission intensities of the flame and hot gases during the burn.
Metal Object	7 μm	Absolute intensity of reflected sun glints, reflected thermal emissions, and radiated thermal emissions.

ACKNOWLEDGEMENTS

The development of the radiometer was sponsored by the Air Force Geophysics Laboratory (AFGL) and the Defense Nuclear Agency. The assistance of the staff members of these agencies and of Utah State University is acknowledged. Of particular mention are the contributions of Dr. A. T. Stair, Jr., (AFGL), Mr. E. R. Huppi (AFGL), Mr. Brian Sandford (AFGL), Major John Reed (AFGL), and Dr. Doran J. Baker (USU) who have provided inputs on practical measurement uses of the instrument.

REFERENCES

1. Huppi, R.J., and D.J. Baker, Intensity Variations of Atmospheric Hydroxyl Emissions, AFCRL-TR-76-0032, Hanscom AFB, 1 January 1976.
2. Stair, A.T., Jr., E.R. Huppi, B.P. Sandford, R.E. Murphy, R.E. O'Neil, A. M. Hart, R.J. Huppi and W.R. Pendleton, "Infrared Investigations of Aurora and Airglow," The Radiating Atmosphere, (Ed. by B.M. McCormack), Dordrecht, Holland, p. 185, 1970.
3. Baker, D.J., A.J. Steed, R.J. Huppi and W.R. Pendleton, Near-Infrared Auroral Spectra, AFCRL-TR-75-0010, Hanscom AFB, 1 January 1975.
4. Baker, D.J., A.J. Steed, R.J. Huppi and K.D. Baker, "Twilight Transition Spectra of Atmospheric O₂ IR Emissions," Geophysical Research Letters, Vol. 2, No. 6, p. 235, 1975.
5. Wyatt, C.L., "Infrared Spectrometer Liquid-Helium-Cooled Rocket-borne Circular-Variable-Filter," Applied Optics, Vol. 14, p. 3086, December 1975.
6. Steed, A.J., and R.H. Haycock, The Development of a Cryogenically-Cooled Field-Widened Interferometer, Contract No. F19628-72-C-0156, Hanscom AFB, December 1973.
7. Bates, D.R., and M. Nicolet, "Photochemistry of Atmospheric Water Vapor," J. Geophys. Res., Vol. 55, p. 301, 1950.
8. Krassovsky, V.I., "The Hydroxyl Emission Problem and Paths of Its Solution," Ann. Geophys., Vol. 27, pp. 211-221, 1971.

APPENDIX A

DISTRIBUTION LIST

Department of Defense

Director
Defense Advanced Rsch Proj Agency
Architect Building
1400 Wilson Blvd.
Arlington, VA 22209
01CY Attn: LTC W. A. Whitaker
01CY Attn: STO Capt. J. Justice
01CY Attn: Major Gregory Canavan

Defense Documentation Center
Cameron Station
Alexandria, VA 22314
12CY Attn: TC

Director
Defense Nuclear Agency
Washington, D. C. 20305
01CY Attn: RAAE Maj. John Clark
01CY Attn: RAAE Harold C. Fitz, Jr.
03CY Attn: RAAE Charles A. Blank
02CY Attn: STTL Tech Library
01CY Attn: SISI Archives

Director of Defense Rsch & Engineering
Department of Defense
Washington D. C. 20301
01CY Attn: AD/S&AS Daniel Brockway
01CY Attn: DDS&SS Richard S. Ruffine

Commander
Field Command
Defense Nuclear Agency
Kirtland AFB, NM 87115
01CY Attn: FCPR

Chief
Livermore Division Fld Command DNA
Lawrence Livermore Laboratory
P. O. Box 808
Livermore, CA 94550
01CY Attn: FCPRL

Weapons Systems Evaluations Group
400 Army Navy Drive
Arlington, VA 22202
01CY Attn: Document Control

Department of the Army

Commander
Harry Diamond Laboratories
2800 Powder Hill Road
Adelphi, MD 20783
O2CY Attn: AMXDO-NP

Director
U.S. Army Ballistic Research Labs
Aberdeen Proving Ground, MD 21005
O1CY Attn: AMXBR-CA Franklin E. Niles

Headquarters
U.S. Army Elct Warfare Lab (ECUM)
Missile Electronic Warfare Tech Area
White Sands Missile Range, NM 88002
O1CY Attn: E. Butterfield

Department of the Navy

Chief of Naval Research
Navy Department
Arlington, VA 22217
O1CY Attn: Code 427 CDR Ronald J. Oberle

Commander
Naval Electronics Laboratory Center
San Diego, CA 92152
O1CY Attn: Code 2200 Ilan Kothmuller
O1CY Attn: Code 2200 I Verne E. Hildebrand

Director
Naval Research Laboratory
Washington, DC 20375
O1CY Attn: Code 7750 Paul Juluene
O1CY Attn: Code 7750 Ellis Hyman
O1CY Attn: Code 7750 Darrell F. Strobel
O1CY Attn: Code 2027 Tech Lib
O1CY Attn: Douglas P. McNutt
O1CY Attn: Code 7750 Timothy P. Coffey
O1CY Attn: Code 7701 Jack D. Brown
O1CY Attn: Code 7127 Charles Y. Johnson
O1CY Attn: Code Douglas Strickland

Commander
Naval Surface Weapons Center
White Oak, Silver Spring, MD 20910
O1CY Attn: Code 213 William L. Derksen
O1CY Attn: Code WA501 Navy Nuc Progms Off

Department of the Air Force

Commander
Aeronautical Systems Division, AFSC
Wright-Patterson AFB, OH 45433
01CY Attn: ASD-YH-EX LTC Robert Levereite

AF Geophysics Labs.
Hanscom Air Force Base
Bedford, MA 01730
01CY Attn: LKB Kenneth S. W. Champion
05CY Attn: OPR James C. Ulwick
01CY Attn: OP John S. Garing
01CY Attn: OPR Alva T. Stair
03CY Attn: OPR Brian P. Sandford

AF Weapons Laboratory, AFSC
Kirtland AFB, NM 87117
01CY Attn: DYT Maj Don Mitchell
01CY Attn: DYT Capt David W. Goetz
01CY Attn: SUL

SAMSO/SZ
P. O. Box 92960
Worldway Postal Center
Los Angeles, CA 90009
01CY Attn: SZJ Maj Lawrence Doan

U.S. Energy Rsch and Dev Admin

Division of Military Application
U.S. Energy Rsch & Dev Admin
Washington, D. C. 20545
01CY Attn: DOC CON for Maj D. A. Haycock

Los Alamos Scientific Laboratory
P. O. Box 1663
Los Alamos, NM 87545
01CY Attn: DOC CON For Milton Peek
01CY Attn: DOC CON For John Zinn

Other Government

Department of Commerce
Office of Telecommunications
Institute for Telecom Science
Boulder, CO 80302
01CY Attn: William F. Utlaut
01CY Attn: Glenn Falcon

Department of Defense Contractors

Aerodyne Research, Inc.
Bedford Research Park
Crosby Drive
Bedford, MA 01703
01CY Attn: M. Camac
01CY Attn: F. Bien

Aerospace Corporation
P. O. Box 92957
Los Angeles, CA 90009
01CY Attn: R. D. Rawcliffe
01CY Attn: R. Grove
01CY Attn: Harris Mayer
01CY Attn: T. Taylor

General Electric Company
Tempo-Center for Advanced Studies
816 State Street (P. O. Drawer QQ)
Santa Barbara, CA 93102
01CY Attn: Warren S. Knapp
05CY Attn: (Dasiac) Art Feryok

General Research Corporation
P. O. Box 3587
Santa Barbara, CA 93105
01CY Attn: John Ise Jr.

Geophysical Institute
University of Alaska
Fairbanks, Alaska 99701
03CY Attn: Neil Brown
01CY Attn: T. N. Davis

Honeywell Incorporated
Radiation Center
2 Forbes Road
Lexington, MA 02173
01CY Attn: W. Williamson

Institute for Defense Analyses
400 Army-Navy Drive
Arlington, VA 22202
01CY Attn: Ernest Bauer
01CY Attn: Hans Wolfhard

Lockheed Missiles and Space Company
3251 Hanover Street
Palo Alto, CA 94304
01CY Attn: John Kumer
01CY Attn: Tom James
01CY Attn: J. B. Reagan
D/52-12
01CY Attn: Robert D. Sears
Dept 52-14
01CY Attn: Richard G. Johnson
Dept 52-12
01CY Attn: Martin Walt
Dept 52-10
01CY Attn: Billy M. McCormac
Dept 52-14

Mission Research Corporation
735 State Street
Santa Barbara, CA 93101
01CY Attn: P. Fischer
01CY Attn: D. Archer

Photometrics, Inc.
442 Marrett Road
Lexington, MA 02173

01CY Attn: Irving L. Kofsky

Physical Dynamics Inc.
P. O. Box 1069
Berkeley, CA 94701
01CY Attn: Joseph B. Workman

Physical Sciences, Inc.
Lakeside Office Park
607 North Avenue, Door 18
Wakefield, MA 01880
01CY Attn: Kurt Wray

R&D Associates
P. O. Box 9695
Marina Del Rey, CA 90291
O1CY Attn: Forest Gilmore
O1CY Attn: Robert E. Lelevier

R&D Associates
1815 N. Ft. Myer Drive
11th Floor
Arlington, VA 22209
O1CY Attn: Herbert J. Mitchell

Rand Corporation
1700 Main Street
Santa Monica, CA 90406
O1CY Attn: James Oakley

Science Applications, Inc.
P. O. Box 2351
La Jolla, CA 92038
O1CY Attn: Daniel A. Hamlin

Space Data Corporation
1331 South 26th Street
Phoenix, AZ 85034
O1CY Attn: Edward F. Allen

Stanford Research Institute
333 Ravenswood Avenue
Menlo Park, CA 94025
O1CY Attn: Ray L. Leadabrand
O1CY Attn: M. Baron
O1CY Attn: Walter G. Chestnut

Stewart Radiance Laboratory
1 DeAngelo Drive, Suite B
Bedford, MA 01730
O1CY Attn: Ronald J. Huppi
O1CY Attn: John Kemp
O1CY Attn: Roy W. Esplin

Technology International Corporation
75 Wiggins Avenue
Bedford, MA 01730
O1CY Attn: W. P. Boquist

Utah State University
Logan, UT 84322
O1CY Attn: Kay Baker
O1CY Attn: Doran Baker
O1CY Attn: C. Wyatt
O1CY Attn: D. Burt

Visidyne, Inc.
19 Third Avenue
North West Industrial Park
Burlington, MA 01803
O1CY Attn: T. C. Degges
O1CY Attn: J. W. Carpenter
O1CY Attn: William Reidy