

AD-A 042 787

TECHNICAL  
LIBRARY

# IMPROVED ULTRASONIC STANDARD REFERENCE BLOCKS

NATIONAL BUREAU OF STANDARDS  
WASHINGTON, D.C. 20234

APRIL 1977

TECHNICAL REPORT AFML-TR-77-40  
FINAL REPORT JANUARY 1974 - DECEMBER 1975

Approved for public release; distribution unlimited

DTIC QUALITY INSPECTED 3

AIR FORCE MATERIALS LABORATORY  
AIR FORCE WRIGHT AERONAUTICAL LABORATORIES  
AIR FORCE SYSTEMS COMMAND  
WRIGHT-PATTERSON AIR FORCE BASE, OHIO 45433

Notice

When Government drawings, specifications, or other data are used for any purpose other than in connection with a definitely related Government procurement operation, the United States Government thereby incurs no responsibility nor any obligation whatsoever; and the fact that the government may have formulated, furnished, or in any way supplied the said drawings, specifications, or other data, is not to be regarded by implication or otherwise as in any manner licensing the holder or any other person or corporation, or conveying any rights or permission to manufacture, use, or sell any patented invention that may in any way be related thereto.

This report has been reviewed by the Information Office (OI) and is releasable to the National Technical Information Service (NTIS). At NTIS it will be available to the general public, including foreign nations.

This technical report has been reviewed and is approved for publication.

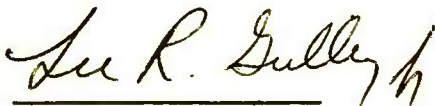

LEE R. GULLEY, JR.  
Project Engineer

FOR THE COMMANDER

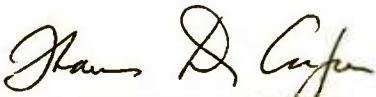

THOMAS D. COOPER, CHIEF  
Materials Integrity Branch  
Systems Support Division

Copies of this report should not be returned unless return is required by security considerations, contractual obligations, or notice on a specific document.

UNCLASSIFIED

SECURITY CLASSIFICATION OF THIS PAGE (When Data Entered)

| REPORT DOCUMENTATION PAGE  |   | READ INSTRUCTIONS<br>BEFORE COMPLETING FORM  |
|--|---|--|
| 1. REPORT NUMBER<br>AFML-TR- 77-40   | 2. GOVT ACCESSION NO.   | 3. RECIPIENT'S CATALOG NUMBER  |
| 4. TITLE (and Subtitle)<br>IMPROVED ULTRASONIC STANDARD<br>REFERENCE BLOCKS  | 5. TYPE OF REPORT & PERIOD COVERED<br>FINAL<br>1 Jan 1974- 31 Dec 1975                                |  |
|  | 6. PERFORMING ORG. REPORT NUMBER<br>NBSIR 76-984  |  |
| 7. AUTHOR(s)<br>G. F. Sushinsky, D. G. Eitzen, D. J. Chwirut,<br>C. J. Bechtoldt, A. W. Ruff   | B. CONTRACT OR GRANT NUMBER(s)<br>DOF33615-74-M6752   |  |
|  | 10. PROGRAM ELEMENT, PROJECT, TASK<br>AREA & WORK UNIT NUMBERS<br>Project No. 7381<br>Task No. 738107 |  |
| 9. PERFORMING ORGANIZATION NAME AND ADDRESS<br>National Bureau of Standards<br>Department of Commerce<br>Washington, D.C. 20234  |   | 11. CONTROLLING OFFICE NAME AND ADDRESS<br>Air Force Materials Laboratory (AFML/MXA)<br>Wright-Patterson AFB, Ohio 45433 |
| 14. MONITORING AGENCY NAME & ADDRESS (if different from Controlling Office)  |   | 12. REPORT DATE<br>April 1977  |
|  |   | 13. NUMBER OF PAGES<br>124   |
|  |   | 15. SECURITY CLASS. (of this report)<br>UNCLASSIFIED   |
|  |   | 15a. DECLASSIFICATION/DOWNGRADING<br>SCHEDULE  |
| 16. DISTRIBUTION STATEMENT (of this Report)<br><br>Approved for public release; distribution unlimited.  |   |  |
| 17. DISTRIBUTION STATEMENT (of the abstract entered in Block 20, if different from Report)   |   |  |
| 18. SUPPLEMENTARY NOTES  |   |  |
| 19. KEY WORDS (Continue on reverse side if necessary and identify by block number)<br>Aluminum ultrasonic standards; ASTM-type reference standards; calibration;<br>fabrication variables; immersion testing; interim reference standard; longitudinal waves; metallurgical variables; nondestructive evaluation; pulse echo; steel ultrasonic standards; titanium ultrasonic standards; ultrasonics.  |   |  |
| 20. ABSTRACT (Continue on reverse side if necessary and identify by block number)<br><br>A program to improve the quality, reproducibility and reliability of nondestructive testing through the development of an improved ASTM-type ultrasonic reference standards system is described. Reference blocks of aluminum, steel, and titanium alloys are considered. Equipment representing the state-of-the-art in laboratory and field ultrasonic equipment was obtained and evaluated. RF and spectral data on twenty-two sets of ultrasonic reference blocks were taken as part of a task to quantify the variability in response from nominally identical |   |  |

DD FORM 1 JAN 73 1473

EDITION OF 1 NOV 65 IS OBSOLETE  
S/N 0102-014-6601UNCLASSIFIED  
SECURITY CLASSIFICATION OF THIS PAGE (When Data Entered)

UNCLASSIFIED

SECURITY CLASSIFICATION OF THIS PAGE(When Data Entered)

20. continued

blocks. Techniques for residual stress, preferred orientation, and microstructural measurements were refined and applied to reference blocks rejected by manufacturers during fabrication in order to evaluate the effect of metallurgical condition on block response. The effects of certain dimensional variables on block response were studied and new fabrication techniques considered. A study of the effects of measurement system variables on block response was carried out. A calibration service for ASTM E127-type reference blocks has been established and the development of a loaner service for calibration blocks is under way.

UNCLASSIFIED

SECURITY CLASSIFICATION OF THIS PAGE(When Data Entered)

## FOREWORD

This report was prepared by the National Bureau of Standards, Washington, D.C. The authors are Dr. D. G. Eitzen, project leader, G. F. Sushinsky, and D. J. Chwirut of the Institute for Basic Standards, and C. J. Bechtoldt and Dr. A. W. Ruff of the Institute for Materials Research.

The following people have made valuable contributions to this program. Their assistance is gratefully acknowledged. G. D. Boswell, G. Elmer, M. Greenspan, C. Tschiegg, F. R. Breckenridge, E. C. Teague, F. Scire, R. Veale, Dr. J. A. Lechner, Hyong Jun Coi, and C. Stull, all of NBS.

Sponsorship and financial assistance were received from the Air Force Materials Laboratory, National Aeronautics and Space Administration (Lewis Research Center), and the Army Materials and Mechanics Research Center. These organizations were technically represented by Lee R. Gulley, Jr., (AFML/MXA), Robert L. Davies, and George Darcy, respectively. The work was administered through the Air Force Materials Laboratory with Lee R. Gulley, Jr. as project monitor. The work was authorized under USAF Delivery Order F-33615-74-M6752 in support of Project No. 7381, Task No. 738107, and was performed during the period 1 January, 1974 to 31 December 1975.

This report was submitted by the authors September 1976.

TABLE OF CONTENTS

| <u>Section</u>  | <u>Page</u> |
|---|-------------|
| I. INTRODUCTION . . . . .                                 | 1           |
| II. PROGRAM OUTLINE . . . . .                             | 5           |
| III. TASK SUMMARY . . . . .                               | 7           |
| 1. Literature Survey. . . . .                             | 7           |
| 2. Ultrasonic Measurement Facility. . . . .               | 9           |
| a. Immersion System . . . . .                             | 9           |
| b. Flaw Detection Equipment . . . . .                     | 9           |
| c. Spectrum Analyzer. . . . .                             | .11         |
| d. Transducers . . . . .                                  | .12         |
| e. Ultrasonic Reference Blocks. . . . .                   | .12         |
| 3. Comparison of Nominally Identical Blocks . . . . .     | .14         |
| a. Ultrasonic Reference Block Comparison . . . . .        | .17         |
| b. 7075-T651 Reference Blocks . . . . .                   | .39         |
| 4. Metallurgical Considerations . . . . .                 | .40         |
| a. Aluminum Block . . . . .                               | .42         |
| b. Steel Block . . . . .                                  | .58         |
| 5. Fabrication Considerations . . . . .                   | .64         |
| a. Dimensional Measurements . . . . .                     | .73         |
| b. Multi-piece Reference Blocks . . . . .                 | .82         |
| 6. Effects of the Ultrasonic Measurement Systems. . . . . | .83         |
| 7. Single Material Standard . . . . .                     | .99         |
| 8. ASTM Participation . . . . .                           | 102         |
| 9. Calibration Service . . . . .                          | 103         |
| a. The Measurement Process . . . . .                      | 103         |
| b. Calibration Service Limitations. . . . .               | 104         |
| IV. CONCLUSIONS . . . . .                                 | 105         |
| APPENDIX A . . . . .                                      | 109         |
| APPENDIX B . . . . .                                      | 112         |
| REFERENCES . . . . .                                      | 123         |

## LIST OF ILLUSTRATIONS

| <u>Figure</u> |  | <u>Page</u> |
|---------------|--|-------------|
| 1.            | ASTM E-127 Ultrasonic Standard Reference Block               | 3           |
| 2.            | Ultrasonic measurement facility                              | 10          |
| 3.            | Distance-amplitude data for No. 3 blocks at 2.25 MHz         | 19          |
| 4.            | Distance-amplitude data for No. 5 blocks at 2.25 MHz         | 20          |
| 5.            | Distance-amplitude data for No. 8 blocks at 2.25 MHz         | 21          |
| 6.            | Distance-amplitude data for No. 3 blocks at 5 MHz            | 22          |
| 7.            | Distance-amplitude data for No. 5 blocks at 5.0 MHz          | 23          |
| 8.            | Distance-amplitude data for No. 8 blocks at 5.0 MHz          | 24          |
| 9.            | Distance-amplitude data for No. 3 blocks at 10 MHz           | 25          |
| 10.           | Distance-amplitude data for No. 5 blocks at 10 MHz           | 26          |
| 11.           | Distance-amplitude data for No. 8 blocks at 10 MHz           | 27          |
| 12.           | Distance-amplitude data for No. 3 blocks at 5.0 MHz (quartz) | 28          |
| 13.           | Distance-amplitude data for No. 5 blocks at 5.0 MHz (quartz) | 29          |
| 14.           | Distance-amplitude data for No. 8 blocks at 5.0 MHz (quartz) | 30          |
| 15.           | Area-amplitude data at 2.25 MHz                              | 31          |
| 16.           | Area-amplitude data at 5.0 MHz                               | 32          |

| <u>Figure</u> |   | <u>Page</u> |
|---------------|---|-------------|
| 17.           | Area-amplitude data at 10 MHz   | 33          |
| 18.           | Area-amplitude data at 5.0 MHz (quartz)   | 34          |
| 19.           | Distance-amplitude data for steel blocks with<br>2.25 MHz ceramic transducer and broadband<br>pulser              | 35          |
| 20.           | Distance-amplitude data for steel blocks with<br>5 MHz ceramic transducer and broadband pulser                    | 36          |
| 21.           | Distance-amplitude data for steel blocks with<br>10 MHz ceramic transducer and broadband pulser                   | 37          |
| 22.           | Distance-amplitude data for steel blocks with<br>5 MHz quartz transducer and tuned pulser                         | 38          |
| 23.           | NBS-fabricated aluminum block surface, as<br>polished   | 43          |
| 24.           | Another surface on NBS-fabricated block   | 44          |
| 25.           | NBS fabricated block etched in NaOH solution  | 45          |
| 26.           | Another surface on NBS fabricated block,<br>etched in HF solution   | 45          |
| 27.           | NBS-fabricated block, as polished surface, X-ray<br>scan trace location is shown                                  | 46          |
| 28.           | X-ray spectra from two areas on surface shown in<br>Fig. 27   | 46          |
| 29.           | Copper X-ray line intensity recorded along scan<br>trace shown in Fig. 5  | 47          |
| 30.           | Etched surface on NBS block   | 47          |
| 31.           | Copper X-ray line intensity recorded along<br>scan track shown in Fig. 8  | 49          |
| 32.           | Etched surface of rejected aluminum block   | 49          |
| 33.           | Copper X-ray line intensity recorded along two<br>lines in different regions on etched rejected<br>aluminum block | 50          |

| <u>Figure</u> |   | <u>Page</u> |
|---------------|---|-------------|
| 34.           | Sectioned NBS aluminum block  | 51          |
| 35.           | NBS Al block surface S5/2 (100) pole  | 52          |
| 36.           | NBS block surface S1 (100) pole   | 53          |
| 37.           | NBS block surface S1 (111) pole   | 55          |
| 38.           | NBS block surface S5/2 (110) pole   | 56          |
| 39.           | NBS block surface S1 (110) pole   | 57          |
| 40.           | Steel block, surface containing hole plug,<br>after nital etch  | 59          |
| 41.           | Steel block, interior surface, after nital<br>etch  | 59          |
| 42.           | Sectioned rejected steel block  | 61          |
| 43.           | 4130 Steel sheet, (110) pole, as rolled   | 65          |
| 44.           | 4130 Steel sheet, (110) pole, electropolished<br>to remove .001 in., Side 2   | 66          |
| 45.           | 4130 Steel sheet (110) pole, electropolished<br>to remove .001 in., Side 1  | 67          |
| 46.           | 4130 Steel sheet (110) pole, electropolished<br>to remove .008 in., Side 2  | 68          |
| 47.           | 4130 Steel sheet, (110) pole, combined transmission<br>and reflection, specimen .002 in. thick, intensity<br>times random | 69          |
| 48.           | 4130 Steel sheet, (200) pole, electropolished to<br>remove .008 in.   | 70          |
| 49.           | 4130 Steel sheet, (211) pole, electropolished to<br>remove .008 in. texture goniometer set for 15 mm<br>oscillation       | 71          |
| 50.           | 4130 Steel sheet, (211) pole, electropolished to<br>remove .008 in.; texture goniometer set for 5 mm<br>oscillation       | 72          |
| 51.           | Surface roughness data (scan 1A) for specimen B-0121<br>(5-0012 reference block)  | 75          |

| <u>Figure</u>   | <u>Page</u> |
|---|-------------|
| 52. "With the grain" surface roughness data for specimen 123 (8-0006 reference block)   | 76          |
| 53. "Across the grain" surface roughness data for specimen 123 (8-0006 reference block) | 77          |
| 54. "With the grain" surface roughness data for specimen 123 (8-0012 reference block)   | 78          |
| 55. "Across the grain" surface roughness data for specimen 123 (8-0012 reference block) | 80          |
| 56. Relative power output versus excitation frequency for transducer LS-1               | 88          |
| 57. Relative power output versus excitation frequency for transducer LS-2               | 89          |
| 58. Relative power output versus excitation frequency for transducer LS-3               | 90          |
| 59. Relative power output versus excitation frequency for transducer LS-4               | 91          |
| 60. Relative power output versus excitation frequency for transducer LS-5               | 92          |
| 61. Data from 1 set of No. 5 reference standards using the NBS system                   | 98          |
| 62. Data from several sets of No. 5 reference blocks using the NBS system               | 100         |

## SECTION I INTRODUCTION

As the field of nondestructive testing and evaluation (NDT&E) continues to increase in scope and importance, the problem of inadequate or non-existent standards has shown itself to be a glaring weakness in the measurement process. In particular, ultrasonic methods, which are highly dependent on reference standards, are characterized by inappropriate and inconsistent reference artifacts, partly because of the demands for defect size characterization brought on by materials shortages and fracture mechanics technology. Standards originally developed for equipment standardization began to be used for sensitivity setting and defect sizing. Inconsistencies in standards used by different operational groups result in uncertainties regarding the actual material condition. These uncertainties lead to performance penalties due to increased design uncertainties and either unnecessary piece rejection or inadequate service performance.

A program to improve the widely used system of ASTM-type standard reference blocks for longitudinal ultrasonic testing was started at NBS in January 1974. At that time, the procedures for fabricating and checking these blocks were covered in two ASTM documents, E 127-64, "Standard Recommended Practice for Fabricating and Checking Aluminum Alloy Ultrasonic Standard Reference Blocks" [1]\*, and E 428-71, "Standard Recommended Practice for Fabrication and Control of Steel Reference Blocks Used in Ultrasonic Inspection" [2]. Both of these documents are widely referenced in government and industry purchasing specifications and in many other ASTM documents. One of the above documents is also sometimes used as a guide for the fabrication of titanium alloy ultrasonic reference blocks. The E 127 document [1] was revised in 1975 [3]. However, both the authors and the users of these documents admit that the documents contain serious shortcomings, but, partly because of other

---

\*Figures in brackets indicate literature references at the end of this paper.

corporate priorities and a lack of institutional mission, no one has produced acceptable improvements through the voluntary standards systems.

The ASTM-type reference blocks are cylindrical blocks with flat-bottomed holes drilled along the block axis, see Figure 1. A pulsed stress wave produced by a piezoelectric transducer enters normal to the undrilled end of the block and travels through the block. The flat end of the drilled hole acts as a reflector and returns some of the energy to the transducer, which converts this energy into an electrical signal. This signal, displayed on a cathode ray tube (CRT), becomes a reference signal for the evaluation of material of unknown condition. Sets of reference blocks with different hole diameters and different lengths are used to standardize ultrasonic measurement systems. Measurements made with these systems then provide a basis for estimating flaw severity and possible material rejection.

The problem with these reference blocks, simply stated, is this: using a single ultrasonic measurement system, the ultrasonic responses from nominally identical reference blocks vary unacceptably. Variations of 40 percent are not uncommon. The problem becomes more acute when different measuring systems are used. The extent of this variation has been reported to be as great as 300 percent in standards produced from titanium [4].

The objectives of the NBS program were to investigate systematically the ASTM-type standard reference block system, to isolate if possible the causes of the variability, and to develop a new system of standards that will allow different organizations to make consistent measurements compatible with each other. It was envisioned that the output from this program could take one of three forms:

- 1) New methods documents to revise or replace ASTM E 127 and E 428 that would allow the NDT community to fabricate standard reference blocks that introduce acceptably small variability into the measurement system,

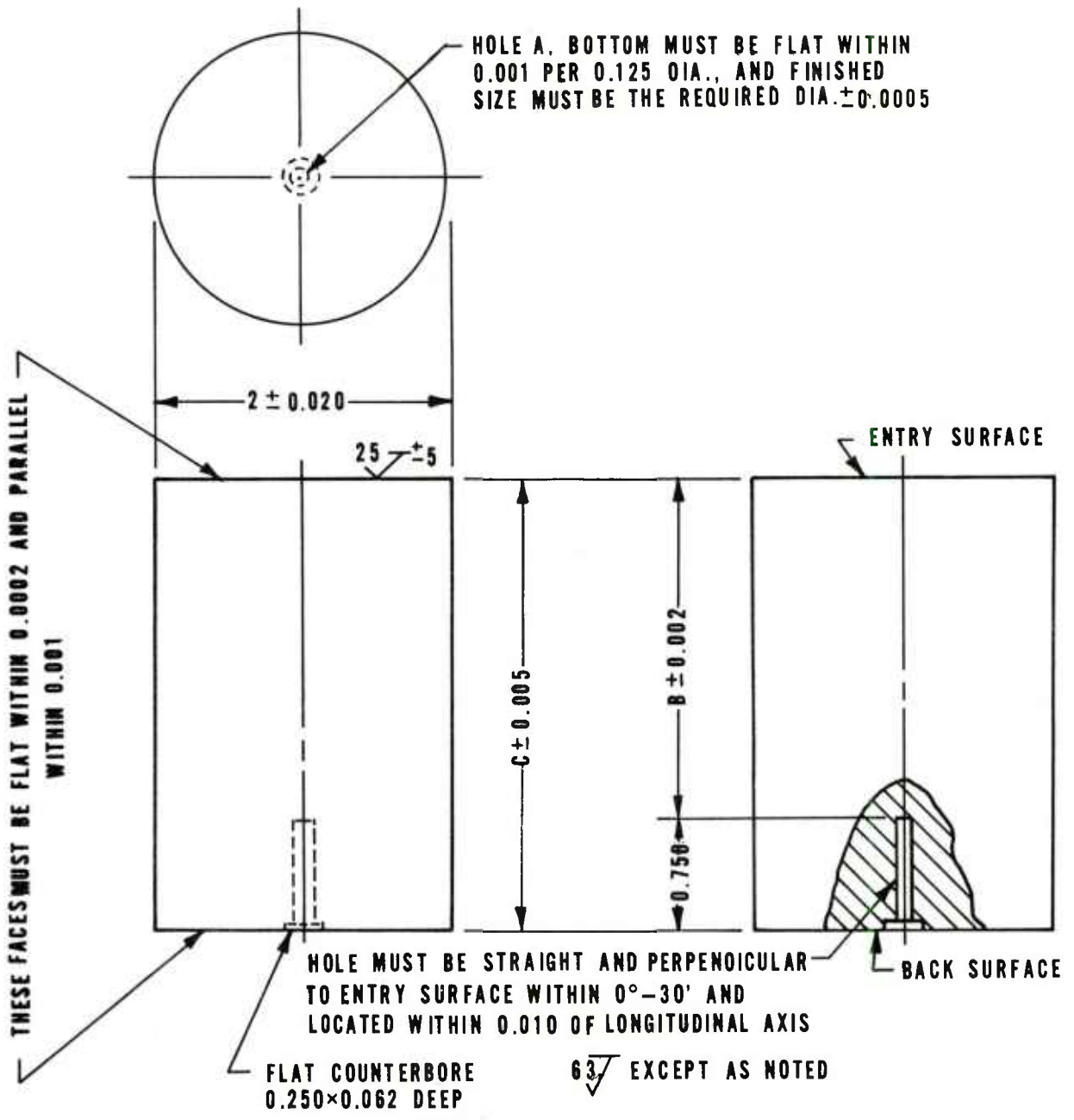

Figure 1— ASTM E-127 ULTRASONIC STANDARD REFERENCE BLOCK  
ALL DIMENSIONS IN INCHES (1 in=25.4 mm).

- 2) a system whereby certified standard reference blocks would be fabricated and sold by the National Bureau of Standards through, for example, the Standard Reference Materials Program,
- 3) a calibration service whereby one set of blocks is defined as THE STANDARD SET. Users' blocks could then be referenced to this set following prescribed procedures.

The NBS program has moved forward in all three areas:

- 1) NBS personnel have become active in the ASTM Sections working on the reference block problem. Technical consultation, editorial assistance, and experimental evaluation of proposed changes have been supplied. Work is continuing on further revisions of these documents.
- 2) A limited number of ASTM-type reference blocks are being fabricated by NBS. These blocks will be carefully characterized by comparison to appropriate references, and offered, on a loan basis, to interested laboratories. These will allow an inter-comparison of results between NBS and other laboratories. This is also the first step in the formulation of a Measurement Assurance Program (MAP) for this type of ultrasonic measurement system.
- 3) A calibration service, limited in scope and availability, has been established at NBS for ASTM E 127-type reference blocks. The details of this service are given in [5] and summarized in Section 3.8 of this report. The service will be generalized.

This activity was performed in the Mechanics and Metallurgy Divisions of the National Bureau of Standards with consultation and support from other Divisions where appropriate.

## SECTION II PROGRAM OUTLINE

As envisioned at the outset, the NBS program was intended to affect near-term improvements in the quality, reproducibility, and reliability of the ultrasonic nondestructive measurement process. These improvements would result from the development of imposed ASTM-type reference blocks and the methodology to accurately characterize these standards metallogically, metrologically, and ultrasonically. The NBS program, described herein, was a planned two-year effort including the following nine tasks:

### Task 1. Literature Search

A thorough search and review of all technical literature regarding ultrasonic test standards will be conducted prior to commencement of any major subsequent tasks. Results of the review will be used where applicable to accelerate or modify subsequent tasks.

### Task 2. Ultrasonic Measurement Facility

State-of-the-art ultrasonic equipment and associated electronics appropriate for pulse-echo contact and immersion evaluations will be obtained. This equipment will be evaluated using current standardization methodology. This evaluation will be performed with a view towards the establishment of standard methods which are more definitive than those currently available. This equipment is intended to form the core of an ultrasonic reference block calibration facility, if established.

### Task 3. Comparison of Nominally Identical Blocks

Nominally identical blocks from commercial sources and from the field will be evaluated for the distribution of ultrasonic response using the equipment of task 2. This task will serve to assess the extent of variability of ultrasonic responses from nominally identical blocks. The results of this evaluation will have an effect on the methods used to identify the causes of the deviations in blocks.

### Task 4. Metallurgical Considerations

The current state of knowledge of the effects of the metallurgical conditions of materials on their ultrasonic characteristics will be reviewed. A limited number of confirmation experiments will be performed.

Additional tests on materials of other metallurgical consistency will be undertaken to determine their ultrasonic response characteristics. This knowledge will be applied to the selection of materials for the fabrication of a master set of ASTM-type ultrasonic reference blocks.

#### Task 5. Fabrication Considerations

A number of nominally identical reference blocks with closely controlled metallurgical properties and fabrication techniques will be obtained. The blocks will be closely examined metrologically and the distribution of ultrasonic response will be determined using the measurements laboratory of Task 2. Several forming techniques will be used including the conventional drilling technique, the use of raw stock formed by powder metallurgy, and the use of two-piece blocks. Comparison of the distributions in response of these blocks with the results of the evaluation of nominally identical field blocks (Task 3) will indicate whether significant reductions in the deviation of ultrasonic response of blocks can be anticipated in the near-term.

#### Task 6. Effects of Ultrasonic Measuring Systems

The results of previous round-robins on ASTM-type reference blocks will be checked to determine whether different ultrasonic measuring systems obtain the same ranking and distribution of ultrasonic response from nominally identical blocks. An additional round-robin will be performed, if necessary. The cooperation of interested NDT users will be sought. The verification of the principle of standardization associated with this task is a necessary step toward the establishment of a rational calibration program.

#### Task 7. Master Reference Blocks

The results of the above tasks will be used to develop master ASTM-type reference standards for aluminum, steel, and titanium. The final alloy selections for the master standards will be based on metallurgical considerations, long-term availability, ultrasonic response, incidence

of structural use, and in consultation with the sponsors.

#### Task 8. A Single-Material Standard

An effort will be made to establish the feasibility of an improved standards program through the use of a single-material master standard. A candidate for the single-material standard is considered to be blocks made of crown glass. This material can be controlled to have an impedance matching that of aluminum, has no crystalline structure, has a minimal defect count (which can be evaluated by light-scattering techniques), and is amenable to the most sophisticated metrological evaluation. Preliminary analyses and tests will establish the feasibility of a one-material standard as the basis for determining the ultrasonic response of reference blocks of various materials. Based on appropriate feasibility indications the development of a basic standard will be considered. Future work may then be proposed in order to establish this standard.

#### Task 9. Calibration Service

An ASTM-type reference block calibration service will be initiated if appropriate. A system will be established to quantify the responses of blocks in terms of the NBS master standards, thus providing a common basis for comparison and an objective evaluation. Blocks will be evaluated in terms of the Master Reference Blocks of Task 7. It is expected that any continuing calibration service will be self-supporting through fees collected from the users.

### SECTION III TASK SUMMARY

#### 1. Literature Survey

An extensive search and review of the open literature regarding ultrasonic reference standards has resulted in a collection of several hundred documents. The search has included four areas: general background information, ultrasonic measurement techniques, previous work directly on standards, and the relationship of metallurgical

variables to ultrasonic response. Formal inputs to the search were received from:

Nondestructive Testing Information and Analysis Center,  
Defense Documentation Center,  
National Technical Information Service, and  
Smithsonian Science Information Exchange.

Of these the input from NTIAC was the most comprehensive. The number of pieces of open literature requiring review was surprisingly large, but few speak directly and conclusively to the problem.

In addition to the open literature, dozens of private documents or communications have been analyzed. The search for unpublished or private communications has been more time consuming but often more substantive. Important information regarding ultrasonic reference standards has been obtained through exchanges with representatives from the numerous government, industrial, and academic institutions from the United States, Canada, United Kingdom, and West Germany.

An important objective of the literature search was the determination of the major causes of the wide distribution of ultrasonic response from nominally identical reference blocks examined with a single system. No definitive conclusion could be drawn. There are significant, but sometimes contradictory or self-serving statements indicating the material, metallurgical, dimensional, or fabrication aspects as the chief cause. However, some positive conclusions were drawn from the review of previous and on-going work. From work in the United Kingdom over the last twenty years it is concluded that "calibrations" by a corrected comparison with a standard set of aluminum blocks can be made to within  $\pm 1$  dB, using state-of-the-art equipment. Sufficient reductions in block disparity to the point where corrections are not required will be difficult [6]. Reports of work at Grumman [7] on reference blocks for titanium concluded that two piece blocks may provide improved standards for this material. Communications concerning work at Westinghouse and Automation Industries indicate that there is a large disagreement about the size of the problem with steel reference blocks. An additional, important conclusion is

that the most active concentrated help can be expected from members of ASTM committee E-7.06. The aluminum producers were particularly cooperative.

## 2. Ultrasonic Measurement Facility

Commercially available, state-of-the-art ultrasonic equipment and accessories suitable for contact and immersion testing have been assembled. This equipment includes an immersion tank with a motorized scanning bridge and precision manipulator, flaw detection equipment with associated gating and amplifying circuitry, a spectrum analyzer, transducers, ultrasonic reference blocks, and other accessory equipment. The laboratory set-up is shown in Figure 2. Brief descriptions of this equipment are included below with more detailed specifications and characteristics given in Appendix A of Reference 8.

### a. Immersion System

The immersion system consists of a tank with transparent walls and dimensions of approximately 38x21x18 in (97x53x46 cm)\*. It is equipped with a motorized bridge and carriage, search tube, motorized manipulator, and mini-manipulator. It provides precision control of search unit positioning in the X, Y and Z directions, as well as angular positioning in two vertical planes normal to the tank bottom. A dry paper X-Y recorder is provided.

### b. Flaw Detection Equipment

Two field inspection type flaw detection units were borrowed from the Air Force Materials Laboratory and the Naval Research Laboratory. These units were used primarily during the initial experimental stages before the delivery of a third unit that was purchased with project funds. All three units feature a tuned, narrow band pulse from a pulser/receiver (P/R) module. With these three units, operating frequencies of 1.0, 2.25, 5.0 and 10.0 MHz are available. A video presentation on a CRT is used for the signal display. Gating and amplifying modules are also

\*Units for physical quantities in this paper are given in both the U.S. Customary Units and the International System Units (SI).

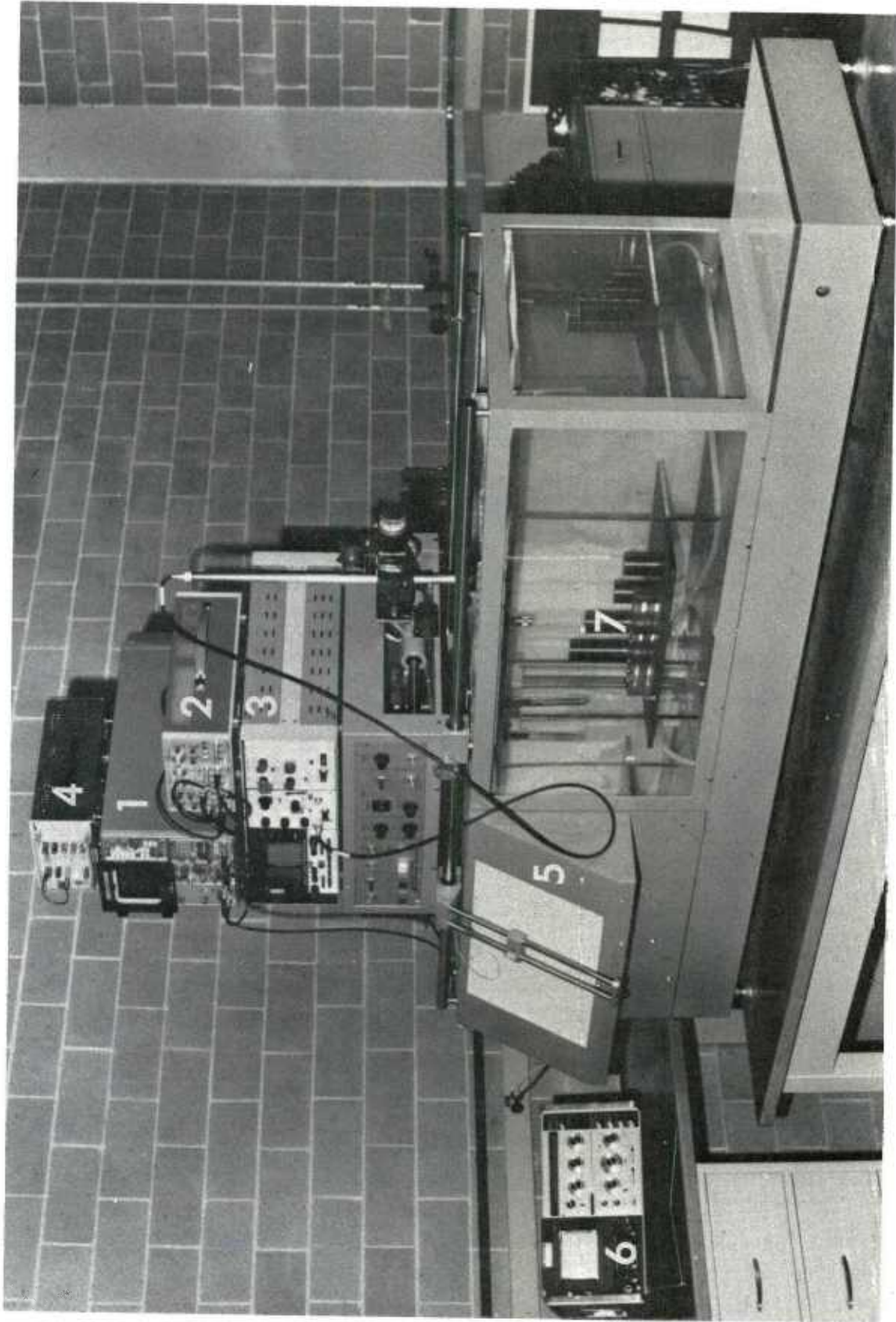

Figure 2 - Ultrasonic measurement facility showing 1) oscilloscope 2) laboratory pulser/receiver, gate, and peak-detector, 3) flaw detector, 4) operational power supply, 5) immersion system, 6) spectrum analyzer, and 7) ultrasonic standard reference blocks.

available. The third unit, while similar to the two borrowed units, represents an improvement to the NBS ultrasonic measurement facility. In addition to the above features, the third unit has a calibrated dB (decibel) sensitivity control, an improved CRT display, and improved gating and amplifying circuitry. All three units are suitable for checking ultrasonic reference blocks per the "Recommended Practice for Fabricating and Checking Aluminum Alloy Ultrasonic Standard Reference Blocks," ASTM Designation E127-75 [3].

A flaw detector suitable for collecting more detailed laboratory data was also purchased. This unit consists of a power supply-frame, a broadband pulser/receiver, a stepless gate, and a peak detection and quantizing module. Ultrasonic rf (radio frequency) signals are displayed on a 100-MHz bandwidth storage oscilloscope equipped with two wideband amplifiers. The stepless gate, peak detector, and quantizer provide flaw and transducer characterization. Signals are routed from the receiver through the stepless gate. In the gate, unwanted signals are eliminated from the repetitive pulse train and the desired wave packet is isolated. This isolated signal can then be used for spectrum analysis work or further processed through the peak detector and quantizer module. The peak detector converts the positive peak amplitude of the signal to a proportional DC voltage. This can then be quantized into discrete DC voltages based on incremental signal amplitude changes. An operational power supply amplifies the discrete DC voltages from the quantizer to provide the voltage levels needed for the electrostatic C-scan recordings. An n-level gray-scale C-scan recording, with the shade of gray proportional to the ultrasonic signal, can thus be obtained for studies such as transducer beam profiling and attenuation measurements.

#### c. Spectrum Analyzer

The spectrum analyzer consists of a storage CRT display, and separate if and rf plug-in modules. The frequency range extends from 0 to 100 MHz with either a logarithmic or linear presentation.

Spectrum analysis is performed on ultrasonic signals received by the transducer after initial processing through the gate circuitry. The signals usually analyzed are those reflected from special targets (e.g. steel

balls, flat quartz blocks, flat-bottom holes, etc.) or defects. This information is necessary for the evaluation of transducer characteristics and potentially helpful in determining defect size and orientation [9, 10].

#### d. Transducers

Transducers were purchased from three manufacturers for use in this program. Both contact and immersion transducers suitable for longitudinal beam, pulse-echo testing were obtained. The transducers were chosen on the basis of nominal crystal diameter and nominal center frequency to cover a representative range of transducers used in ultrasonic work. These transducers are listed in Table 1. Special emphasis was placed on obtaining transducers suitable for work on standard reference blocks in accordance with ASTM E127-64 [1] and ASTM E127-75 [3], as well as transducer size and frequency combinations suitable for establishing the data base in Task 3.

#### e. Ultrasonic Reference Blocks

Seven sets of ultrasonic reference standards were purchased from three different sources. These sets were comprised of three "Distance/Area Amplitude (basic) sets, purchased from the Defense Supply Agency (the source of most Air Force field blocks), and four "Distance Amplitude" sets. The basic sets were all the product of one manufacturer. The Distance Amplitude sets, purchased directly from the manufacturer, consisted of two sets of "number 3"\* blocks from a second manufacturer and one set each of "number 5 and 8" blocks from the third manufacturer. This sample will provide some measure of the inconsistency of products manufactured by different producers as well as the variability of the standards produced by the same manufacturer. These sets constitute part of the data base established at the NBS laboratory. In addition, these reference blocks provide convenient working standards for the other activities in the program.

---

\*These reference standards are commonly referred to as "number x" blocks where x represents the diameter of the "flat-bottomed hole in 64 THS of an inch (1 in = 2.54 cm)."

TABLE 1. ULTRASONIC TRANSDUCERS

| Size<br>in<br>cm | Frequency (MHz) |         |           |         |           |         |           |         |           |         |           |         |
|------------------|-----------------|---------|-----------|---------|-----------|---------|-----------|---------|-----------|---------|-----------|---------|
|                  | 2.25            |         | 5.0       |         | 10.0      |         | 15.0      |         | 10.0      |         | 15.0      |         |
|                  | Immersion       | Contact | Immersion | Contact | Immersion | Contact | Immersion | Contact | Immersion | Contact | Immersion | Contact |
| 0.25 0.63        |                 |         |           |         | 4         |         |           |         | 1         |         | 1         | 1       |
| 0.375 0.953      |                 |         | 6         |         |           | 1       |           |         | 5         |         |           |         |
| 0.5 1.27         | 2               | 1       | 3         | 2       | 2         | 1       |           |         | 1         |         |           |         |
| 0.75 1.9         |                 |         |           |         | 1(a)      |         |           |         |           |         |           |         |

(a) Focused

### 3. Comparison of Nominally Identical Blocks

Of major concern to the producers and users of ultrasonic reference blocks is the large variability of response from "nominally identical" standards. While this problem is widely acknowledged, the extent of the problem is not well documented. The literature search produced only two quantitative references to this problem. Reference [4] reported a 300% variability in the response from nominally identical titanium standards checked in a round-robin procedure. With regard to aluminum reference blocks, a report by the Aeronautical Quality Assurance Directorate (United Kingdom) [6] concludes that blocks could be fabricated and calibrated (by the assignation of correction factors with respect to a master set) with an uncertainty of  $\pm 1$  dB. But ASTM E127-75 [3] recognizes a practical problem of greater magnitude and allows for a  $\pm 2$  dB variability around a "nominal" value. The measurement of the extent of this variability was the primary intent of Task 3.

In order to establish a representative data base of the response from ultrasonic reference blocks, the assistance of the NDT community was sought. This was done through a personal appeal for the loan of reference blocks to the members of ASTM E07.06, the ultrasonics subcommittee of the committee for nondestructive testing, an appeal to the general NDT community through the NTIAC Newsletter, and through numerous private communications. Reference blocks were received from the organizations listed in Table 2.

Pulse-echo response data were taken on all the block sets at the test frequencies of 2.25, 5.0 and 10.0 MHz, using the immersion set-up, broadband pulser/receiver, stepless gate, oscilloscope, and spectrum analyzer described in Section III-2. Additional data were obtained from all but one block set using nominally identical 5.0 MHz, 0.375-in (0.952 cm) diameter quartz crystal transducers and the tuned, field-type, flaw detection equipment described previously. The block sets evaluated, the transducers used, and the number of data sets taken are summarized in Table 3.

TABLE 2. ORGANIZATIONS PROVIDING REFERENCE BLOCKS FOR TASK 3

Air Force Materials Lab  
Aluminum Company of America  
Battelle Memorial Institute - Columbus  
Curtiss-Wright Corporation  
Grumman Aerospace Corporation  
LTV Aerospace Corporation  
NASA Lewis Research Center  
Naval Research Lab (NRL)  
Ohio State University  
Reynolds Metals Company  
Westinghouse Electric Corporation  
Wyman-Gordon Company

TABLE 3. REFERENCE BLOCKS CHECKED BY NBS. NUMBERS INDICATE NUMBER OF INDEPENDENT DATA RUNS TAKEN WITH EACH TRANSDUCER.

| Type       | Lender         | Mat      | Hole Size<br>in | S.N.    | 3529 (a)<br>(b) | 3062<br>(c) | 3065 | 4263 | 4750 | 6249 | 4128 | None | LS-1<br>Quartz | LS-2<br>Quartz | LS-3<br>Quartz | LS-4<br>Quartz | LS-5<br>Quartz | 5462<br>Quartz | 015463<br>Quartz |
|------------|----------------|----------|-----------------|---------|-----------------|-------------|------|------|------|------|------|------|----------------|----------------|----------------|----------------|----------------|----------------|------------------|
| DAC        | Reynolds       | Al.      | 3/64            | 151-3   | 1               | 1           | 1    | 1    | 1    | 1    | 1    | 3    |                |                |                |                |                |                |                  |
|            | Reynolds       | Al.      | 5/64            | 150-3   | 1               | 1           | 1    | 1    | 1    | 1    | 1    | 3    |                |                |                |                |                |                |                  |
|            | Reynolds       | Al.      | 5/64            | None    | 1               | 1           | 1    | 1    | 1    | 1    | 1    | 1    |                |                |                |                |                |                |                  |
|            | Reynolds       | Al.      | 8/64            | 148-3   | 1               | 1           | 1    | 1    | 1    | 1    | 2    | 1    |                |                |                |                |                |                |                  |
|            | Ohio State     | Al.      | 3/64            | Various | 1               | 1           | 1    | 1    | 1    | 1    | 2    | 2    |                |                |                |                |                |                |                  |
|            | NBS            | Al.      | 3/64            | 152-4   | 1               | 1           | 1    | 1    | 1    | 1    | 8    | 10   |                |                |                |                |                |                |                  |
|            | NBS            | Al.      | 3/64            | 154-4   | 1               | 1           | 1    | 1    | 1    | 1    | 9    | 7    |                |                |                |                |                |                |                  |
|            | NBS            | Al.      | 5/64            | 122     | 1               | 1           | 1    | 1    | 1    | 1    | 4    | 4    |                |                |                |                |                |                |                  |
|            | NBS            | Al.      | 8/64            | 123     | 1               | 1           | 1    | 1    | 1    | 1    | 7    | 4    |                |                |                |                |                |                |                  |
|            | Alcoa          | Al.      | 3/64            | Various | 1               | 1           | 1    | 1    | 1    | 1    | 1    | 1    |                |                |                |                |                |                |                  |
|            | Alcoa          | Al.      | 5/64            | Various | 1               | 1           | 1    | 1    | 1    | 1    | 1    | 1    |                |                |                |                |                |                |                  |
|            | Alcoa          | Al.      | 8/64            | Various | 1               | 1           | 1    | 1    | 1    | 1    | 1    | 1    |                |                |                |                |                |                |                  |
|            | AFPL           | Al.      | 5/64            | AFE-4   | 1               | 1           | 1    | 1    | 1    | 1    | 1    | 1    |                |                |                |                |                |                |                  |
| AA         | Wyman-Gordon   | Al.      |                 | 144-4   | 2               | 2           | 1    | 1    | 1    | 1    | 1    | 1    |                |                |                |                |                |                |                  |
|            | Wyman-Gordon   | Al.      |                 | 146-4   | 2               | 2           | 2    | 2    | 2    | 3    | 3    | 4    |                |                |                |                |                |                |                  |
|            | LTV            | Al.      |                 | Various | 1               | 1           | 1    | 1    | 1    | 1    | 1    | 4    |                |                |                |                |                |                |                  |
|            | Ohio State     | Al.      |                 | Various | 1               | 1           | 1    | 1    | 1    | 1    | 1    | 1    |                |                |                |                |                |                |                  |
|            | Curtiss-Wright | Al.      |                 | A0729   | 2               | 2           | 2    | 2    | 2    | 2    | 2    | 2    |                |                |                |                |                |                |                  |
| Basic      | Ohio State     | 4130 STL |                 | 654     | 1               | 1           | 1    | 1    | 1    | 1    | 1    | 1    |                |                |                |                |                |                |                  |
|            | NASA           | 4340 STL |                 | 1271    | 1               | 1           | 1    | 1    | 1    | 1    | 1    | 1    |                |                |                |                |                |                |                  |
|            | NBS            | Al.      |                 | 0109    | 1               | 1           | 1    | 2    | 1    | 1    | 1    | 1    |                |                |                |                |                |                |                  |
|            | NBS            | Al.      |                 | 0121    | 1               | 1           | 1    | 1    | 1    | 1    | 1    | 1    |                |                |                |                |                |                |                  |
|            | NBS            | Al.      |                 | 0122    | 1               | 1           | 1    | 1    | 1    | 1    | 1    | 1    |                |                |                |                |                |                |                  |
| Res. Block | NASA           | STL      |                 | None    | 1               | 1           | 1    | 1    | 1    | 1    | 1    | 1    |                |                |                |                |                |                |                  |
| Misc.      | Westinghouse   | STL      |                 | 12#107  | 1               | 1           | 1    | 1    | 1    | 1    | 1    | 1    |                |                |                |                |                |                |                  |
| Misc.      | Grumman        | II       |                 | None    | 1               | 1           | 1    | 1    | 1    | 1    | 1    | 1    |                |                |                |                |                |                |                  |

(a) Transducer Serial Number

(b) Frequency (MHz)

(c) Size (in)

During the data-taking process, all pulser/receiver settings were set in repeatable positions. The system gain was generally set by standardizing the reflected signal from a steel ball. Some data sets were taken using the quartz transducers standardized on the signal from a selected reference block. The normal standardization points using steel balls are given in Table 4. These standardization points are only a basis for the comparison of nominally identical blocks. They were chosen to give the response closest to the response of a reference block with a 0.500-in (13 mm) metal travel distance from the first set of blocks checked at NBS.

Photorecordings were made of the radio frequency (rf) signal reflected from the flat-bottomed hole and the spectrum of the gated rf waveform when the broadband system was used. Only amplitude response data were recorded using the tuned flaw detection system. Details of the mechanics of data-taking, transducer characteristics, and typical waveform photographs are included in the first annual report [5].

#### a. Ultrasonic Reference Block Comparison

Nineteen sets of borrowed reference blocks were evaluated during the two-year program along with the seven sets of blocks purchased by NBS. The data taken from the distance amplitude (DAC), area amplitude (AA), and basic sets are shown in Figs. 3-22 for aluminum and steel reference block sets. The mean values of response are plotted for nominally identical blocks evaluated under nominally identical conditions. The bars represent the spread in response from nominally identical blocks, and the numbers indicate the number of blocks checked. The B-curve shown in figures 12-14 and later represents an increase in instrument gain for long metal distance blocks in order to improve measurement resolution. Variations in the response from nominally identical blocks was generally less than 40 percent (within the  $\pm 2$  dB limits of E127-75) at the test frequencies from 2.25 to 10 MHz, but variations in excess of 700 percent were also measured [8, Fig. 8]. The data from this highly variant (700 percent) block set was not included in the present data because it would only add to an already confused situation. There is some background information that indicates that this particular set of reference blocks was fabricated several years ago from drawn aluminum rod rather than rolled rod as specified in [1]. While this fact may point to metallurgical parameters as the major causes for the variation in response in this case, the problems represented by a "normal" variation of 40 percent cannot be dismissed as readily.

TABLE 4. STANDARDIZATION POINTS FOR REFERENCE BLOCKS IN THE NBS DATA BASE

| <u>Block Hole Size</u> |           | <u>Material</u> | <u>Test</u>                    | <u>Ball Diameter</u> |           | <u>Amplitude</u><br><u>v</u> |
|------------------------|-----------|-----------------|--------------------------------|----------------------|-----------|------------------------------|
| <u>in</u>              | <u>mm</u> |                 | <u>Frequency</u><br><u>MHz</u> | <u>in</u>            | <u>mm</u> |                              |
| 0.047(#3)              | 1.19      | A1              | 2.25                           | 0.0625               | 1.588     | 1.20                         |
| 0.047                  | 1.19      | A1              | 5.0                            | 0.1875               | 4.762     | 1.20                         |
| 0.047                  | 1.19      | A1              | 10.0                           | 0.2812               | 7.144     | 0.60                         |
| 0.078(#5)              | 1.98      | A1              | 2.25                           | 0.1250               | 3.175     | 1.28                         |
| 0.078                  | 1.98      | St1             | 2.25                           | 0.0625               | 1.588     | 1.20                         |
| 0.078                  | 1.98      | A1              | 5.0                            | 0.4375               | 11.112    | 1.20                         |
| 0.078                  | 1.98      | St1             | 5.0                            | 0.2188               | 5.556     | 1.50                         |
| 0.078                  | 1.98      | A1              | 10.0                           | 0.6250               | 15.875    | 0.60                         |
| 0.078                  | 1.98      | St1             | 10.0                           | 0.2188               | 5.556     | 0.60                         |
| 0.125(#8)              | 3.18      | A1              | 2.25                           | 0.3125               | 7.938     | 1.20                         |
| 0.125                  | 3.18      | A1              | 5.0                            | 1.0000               | 25.400    | 1.20                         |
| 0.125                  | 3.18      | A1              | 10.0                           | 1.0625               | 26.988    | 0.58                         |
| 0.047                  | 1.19      | A1              | 5.0*                           | 0.1250               | 3.175     | 80% F.S.                     |
| 0.078                  | 1.98      | A1              | 5.0*                           | 0.3125               | 7.938     | 80% F.S.                     |
| 0.078                  | 1.98      | St1             | 5.0*                           | 0.1250               | 3.175     | 80% F.S.                     |
| 0.125                  | 3.18      | A1              | 5.0*                           | 0.6875               | 17.462    | 80% F.S.                     |

---

\*(Quartz)

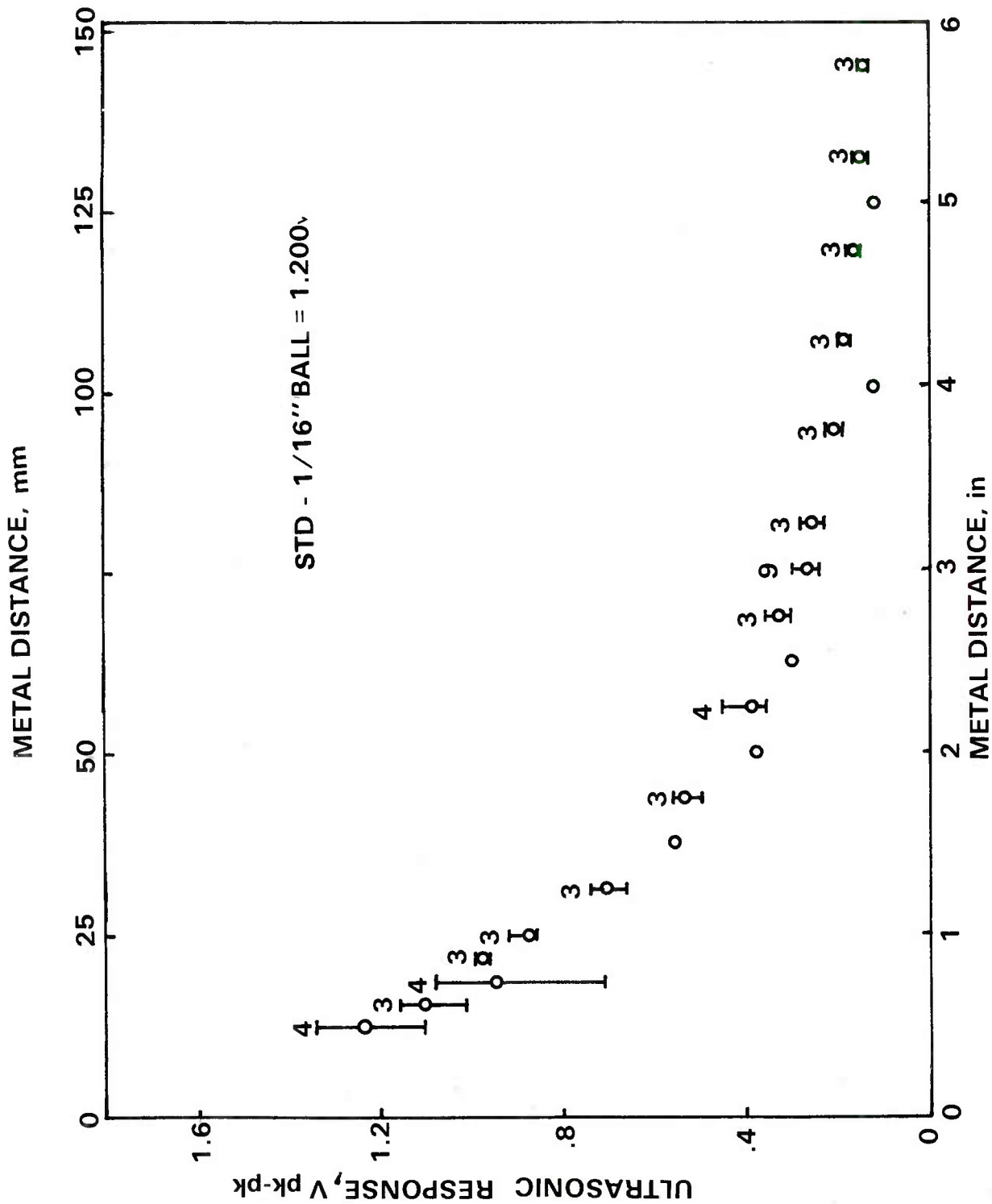

Fig. 3 - DISTANCE-AMPLITUDE DATA FOR NO. 3 BLOCKS AT 2.25 MHz

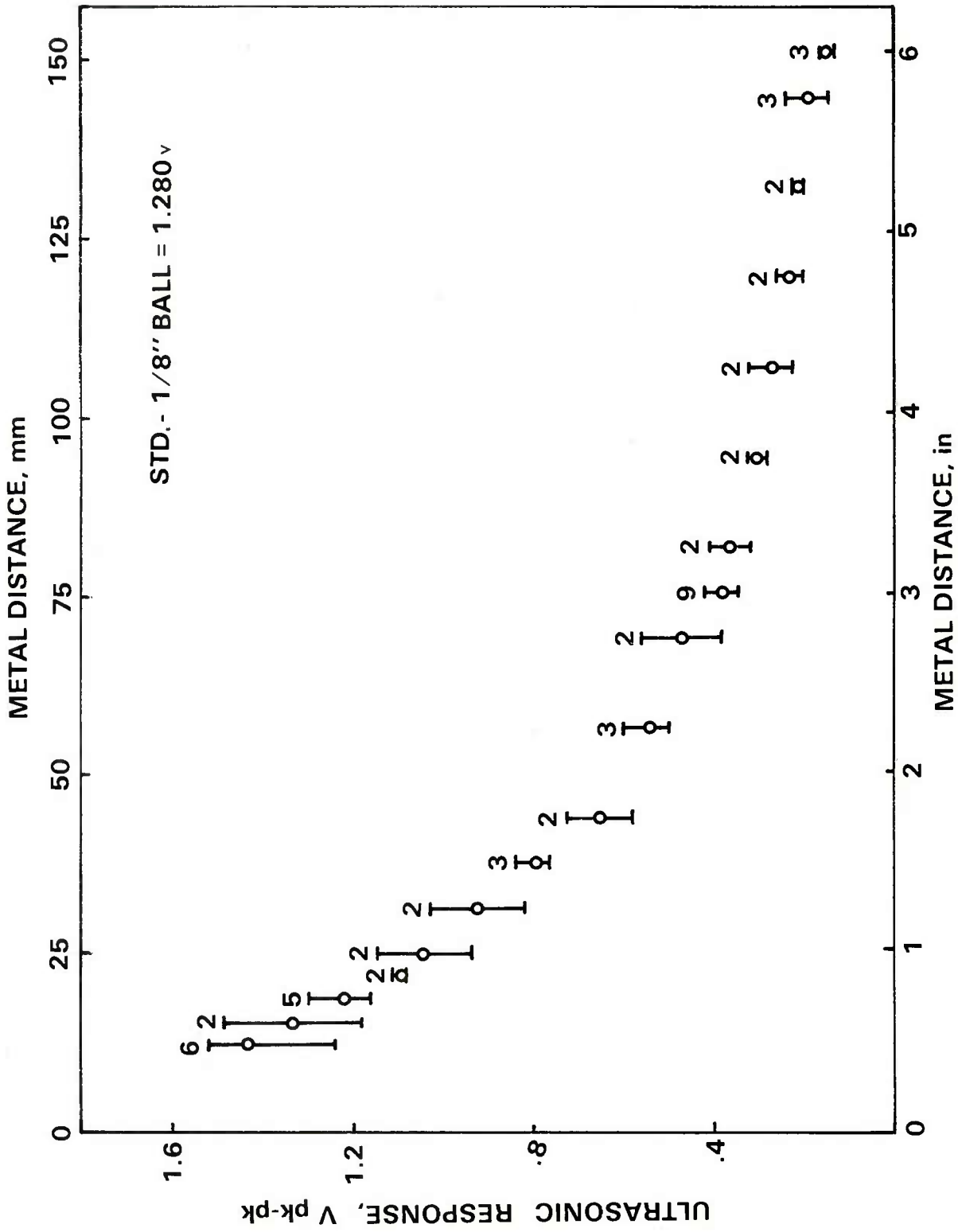

Fig. 4 - DISTANCE-AMPLITUDE DATA FOR NO. 5 BLOCKS AT 2.25 MHz

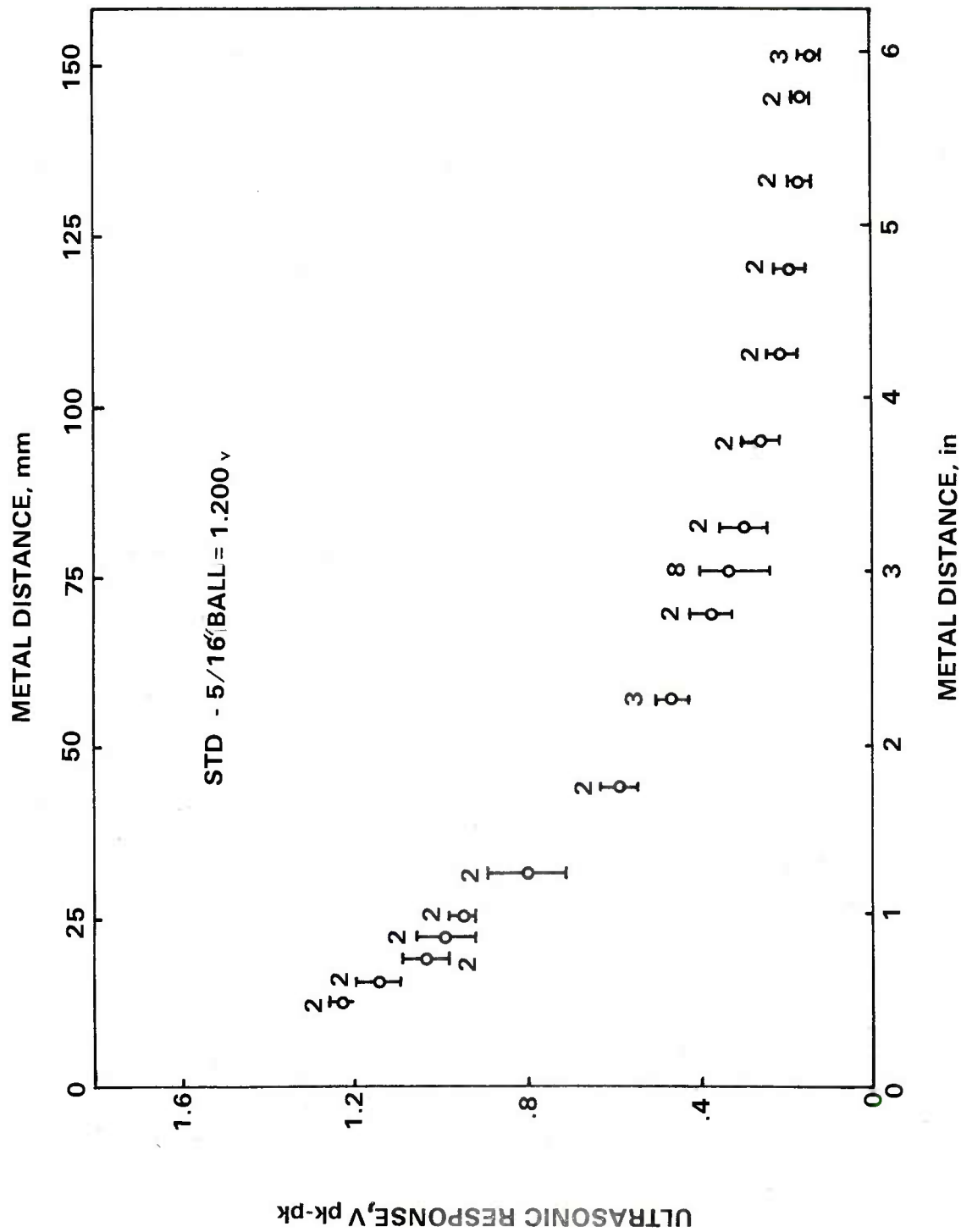

Fig. 5-DISTANCE-AMPLITUDE DATA FOR NO. 8 BLOCKS AT 2.25 MHz

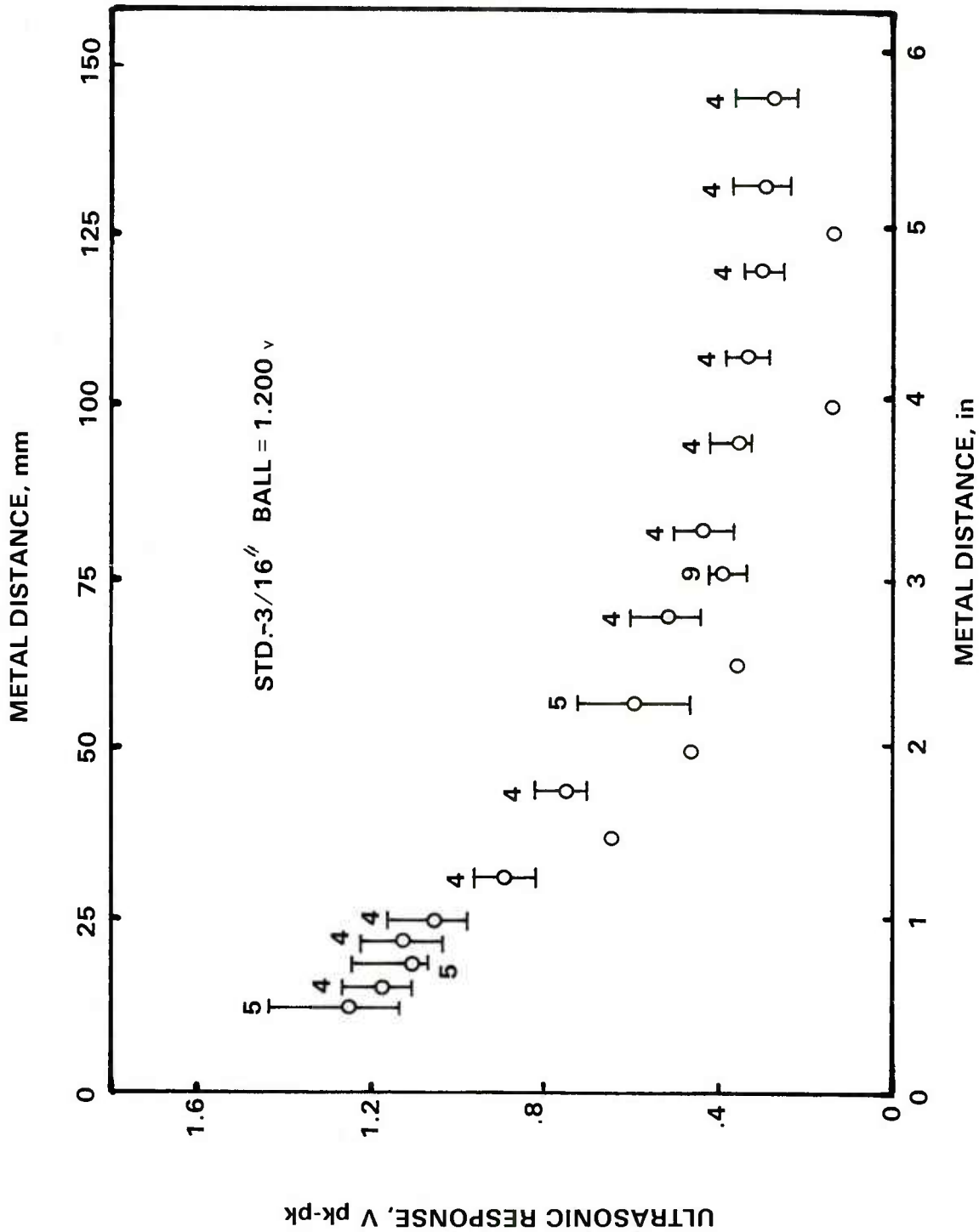

Fig. 6-DISTANCE-AMPLITUDE DATA FOR NO. 3 BLOCKS AT 5 MHz

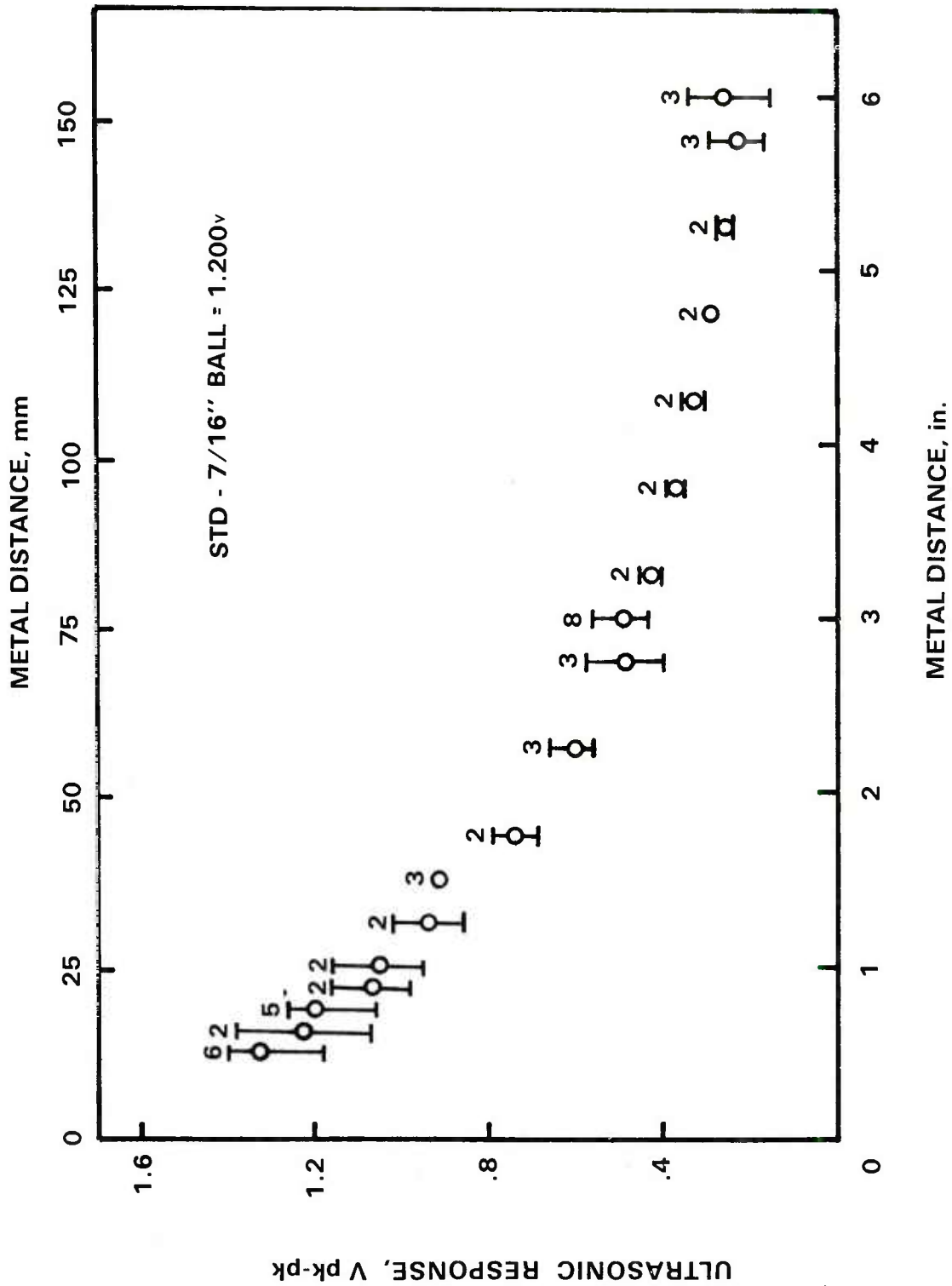

Fig. 7 - DISTANCE-AMPLITUDE DATA FOR NO. 5 BLOCKS AT 5.0 MHz

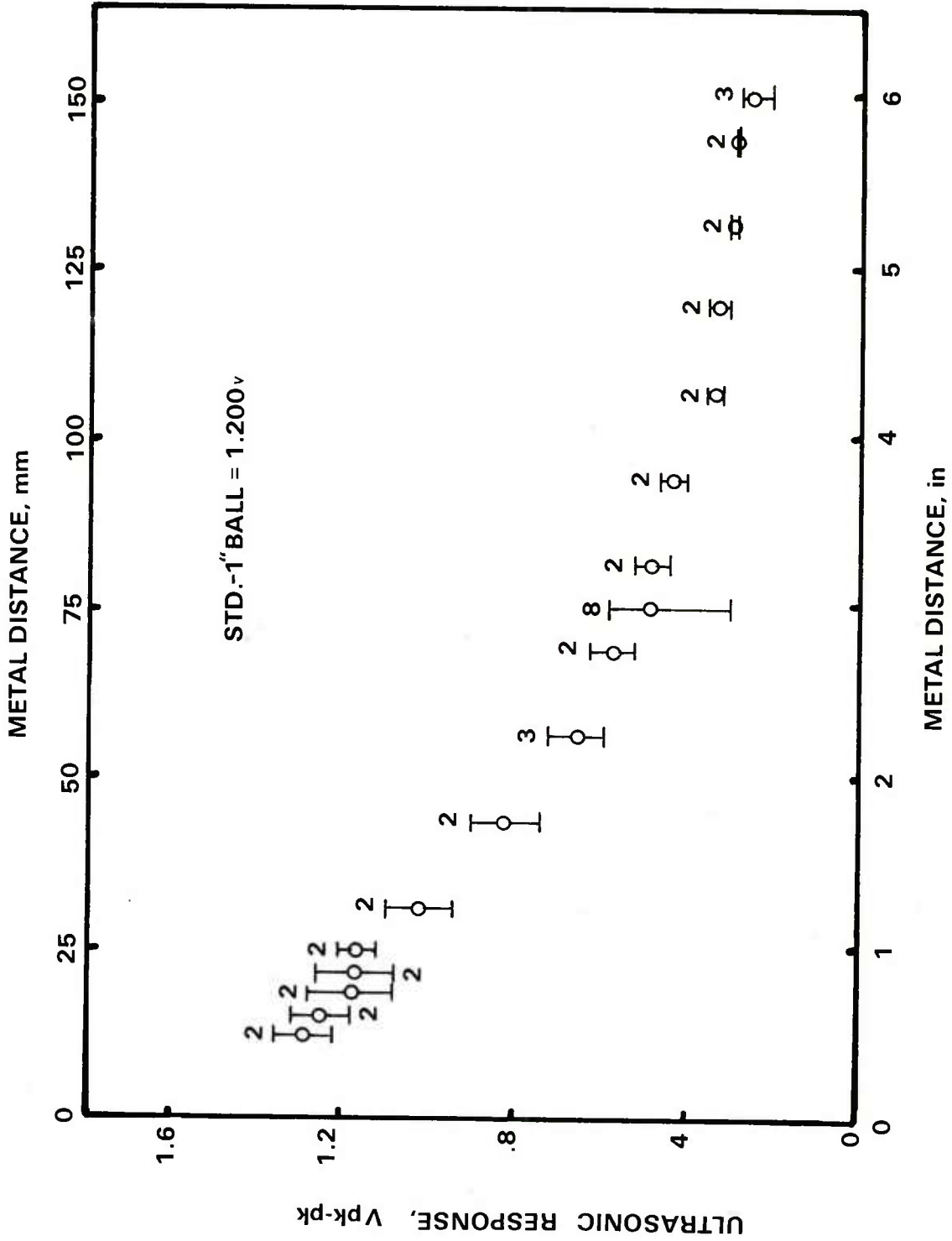

Fig. 8 - DISTANCE-AMPLITUDE DATA FOR NO. 8 BLOCKS AT 5.0 MH z

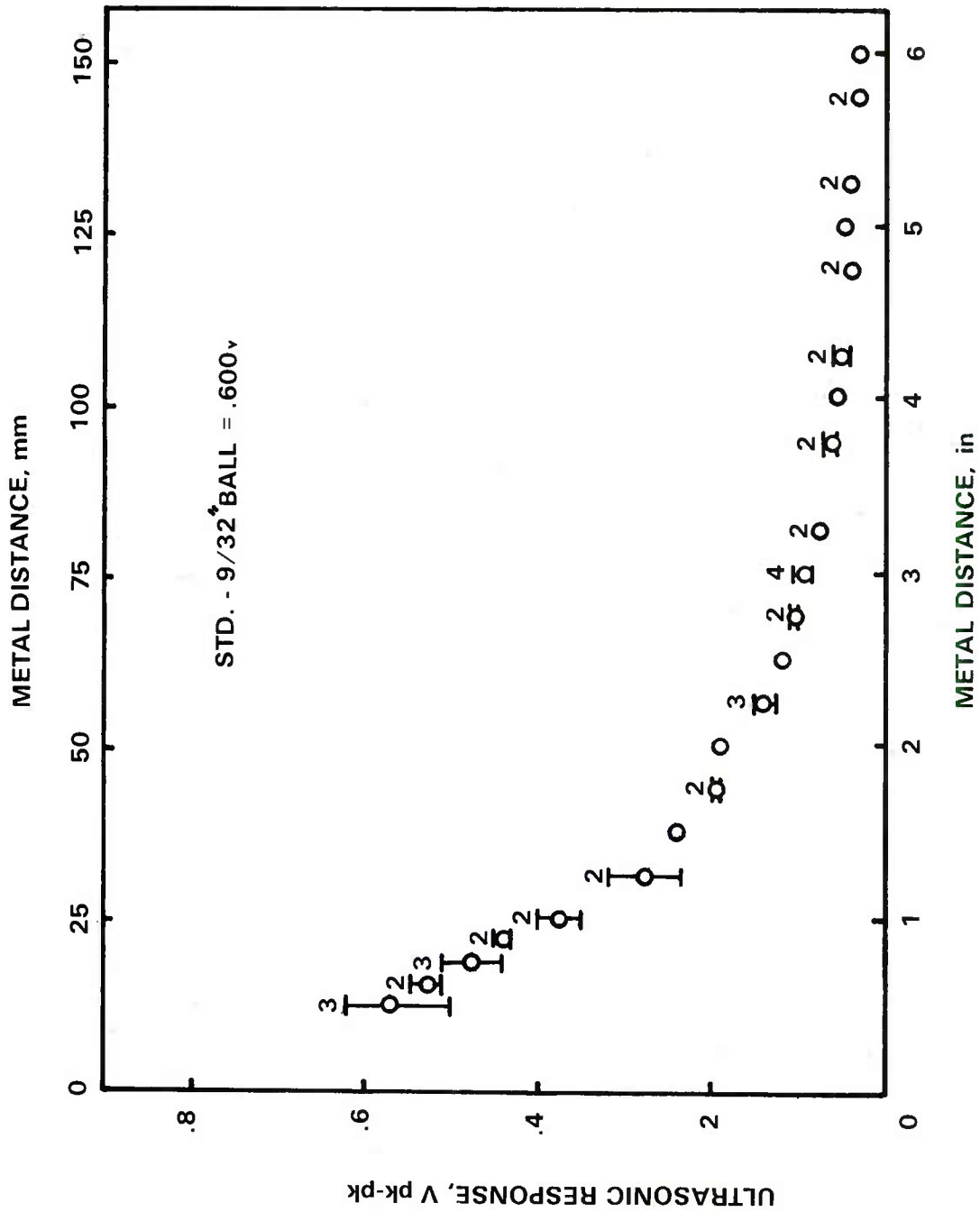

Fig. 9 - DISTANCE-AMPLITUDE DATA FOR NO. 3 BLOCKS AT 10 MHz

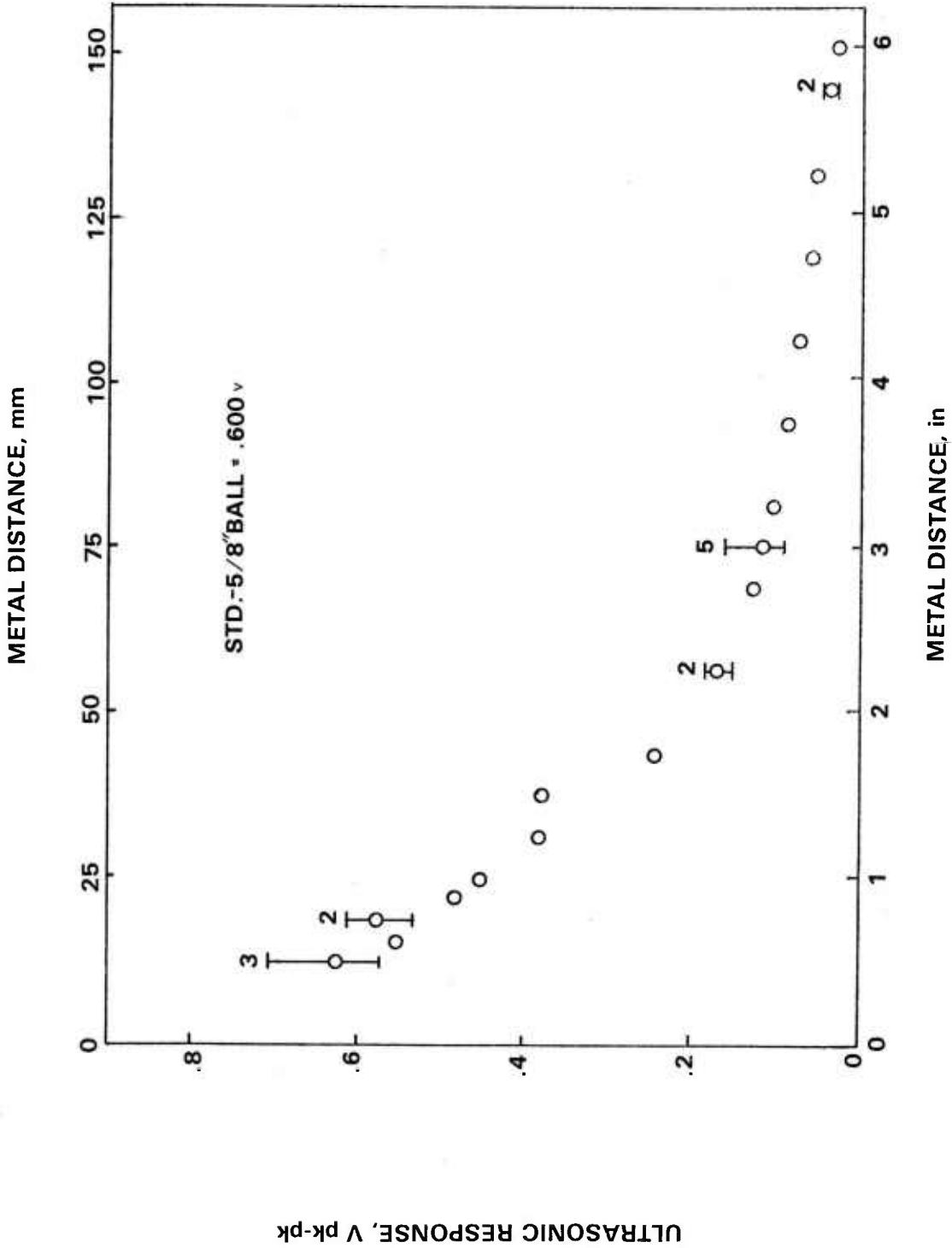

Fig. 10 - DISTANCE-AMPLITUDE DATA FOR NO. 5 BLOCKS AT 10 MHz

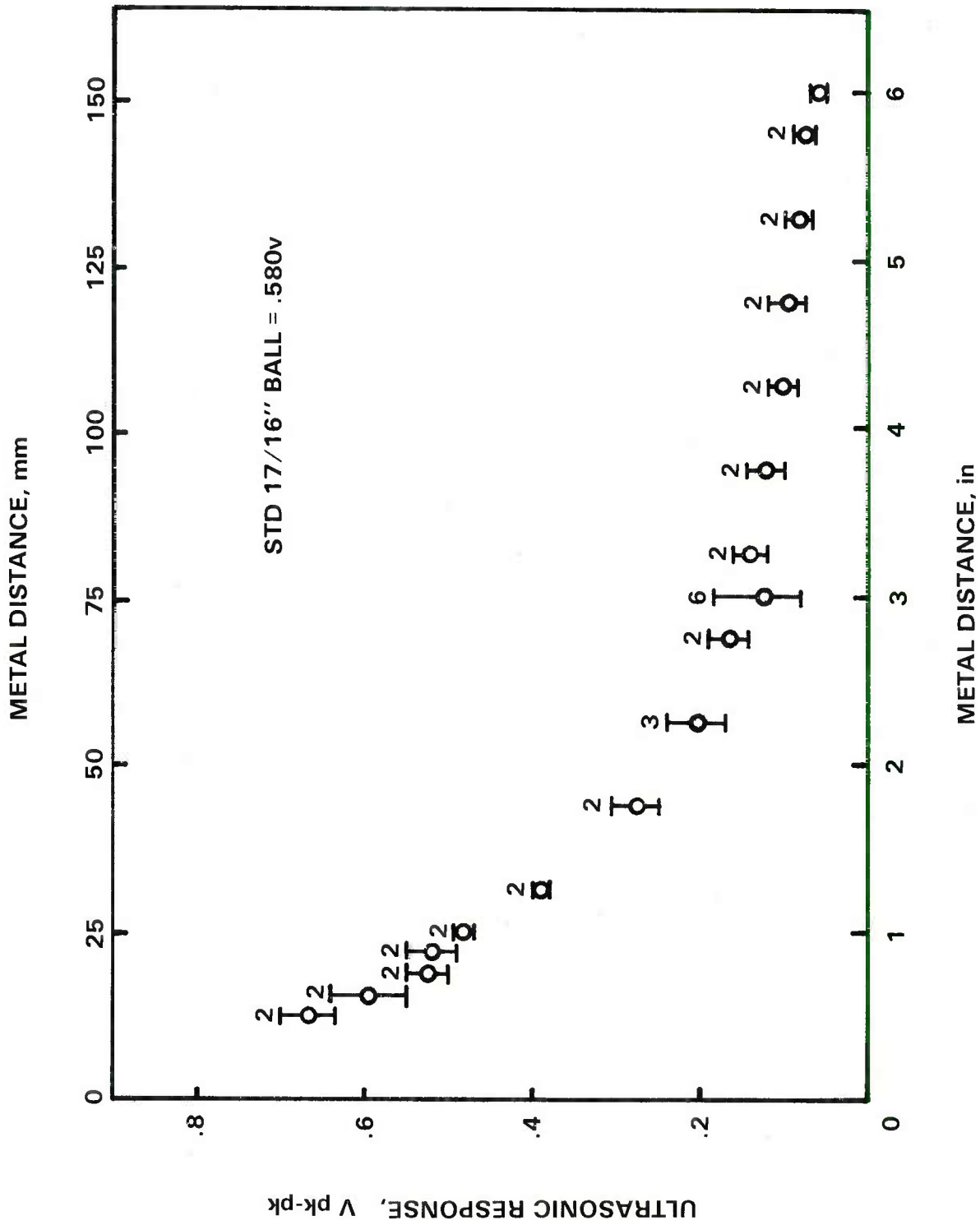

Fig. 11 - DISTANCE-AMPLITUDE DATA FOR NO. 8 BLOCKS AT 10 MHz

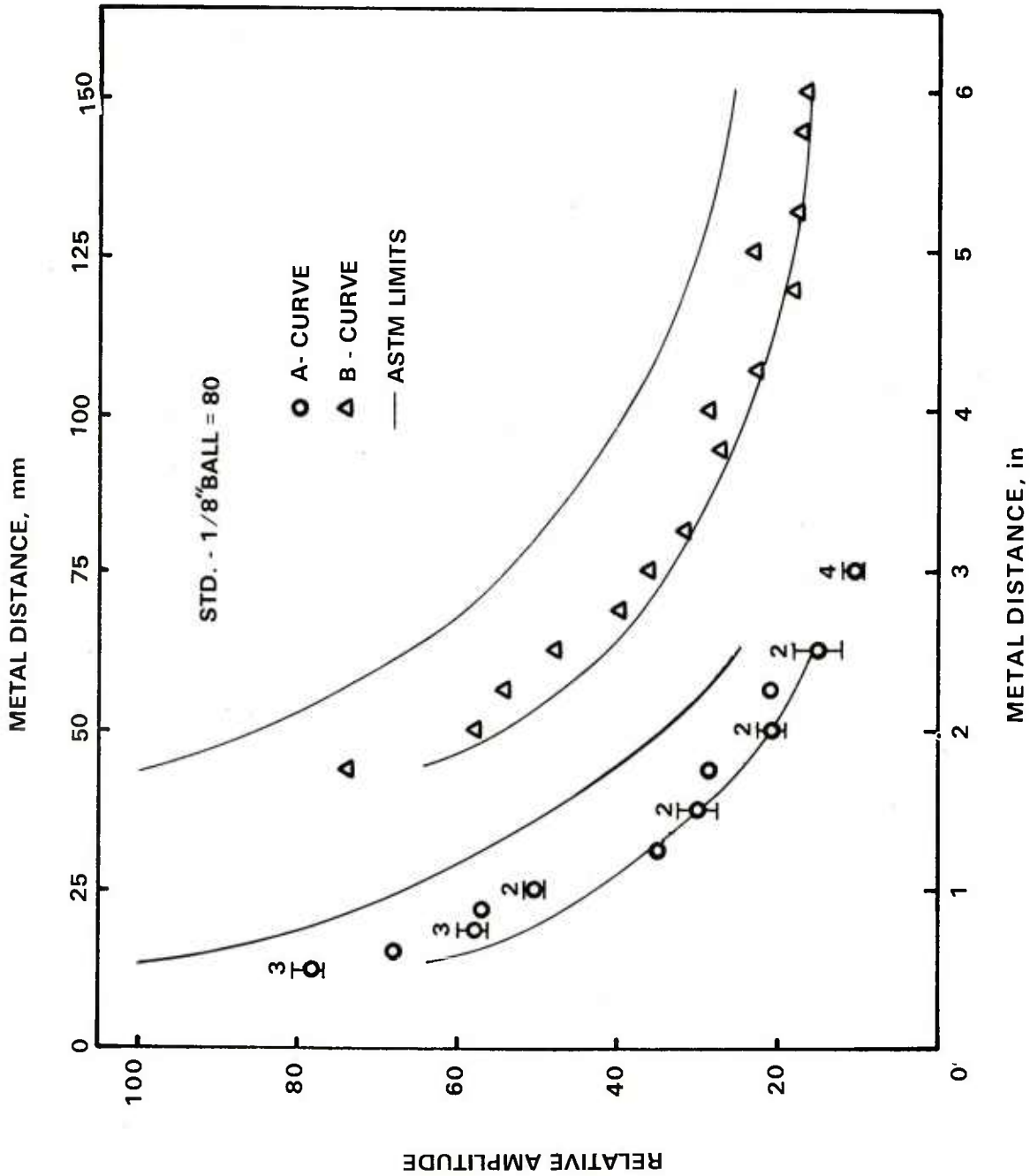

Fig. 12-DISTANCE-AMPLITUDE DATA FOR NO. 3 BLOCKS AT 5.0 MHz (QUARTZ)

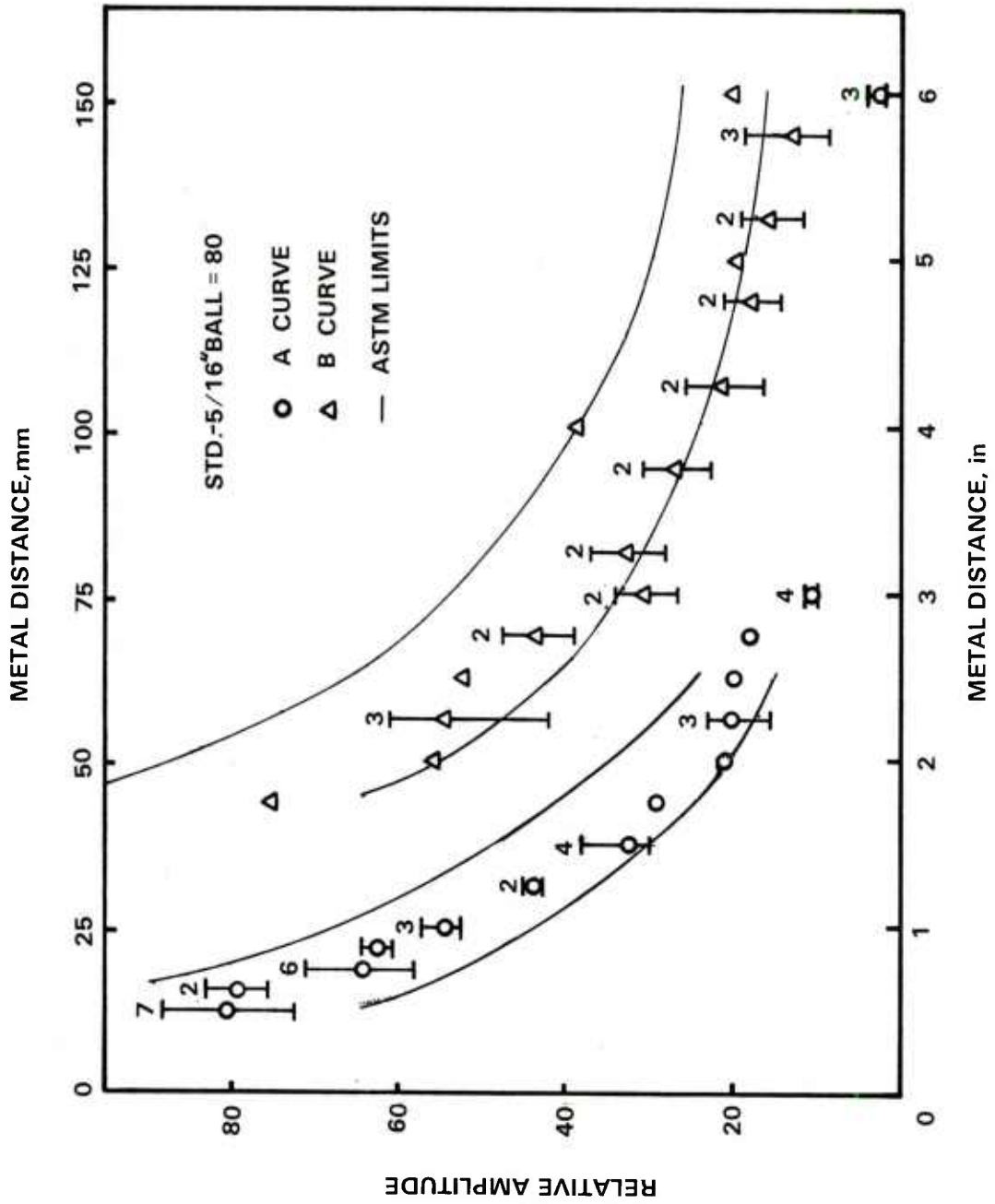

Fig. 13-DISTANCE - AMPLITUDE DATA FOR NO. 5 BLOCKS AT 5.0 MHz (QUARTZ)

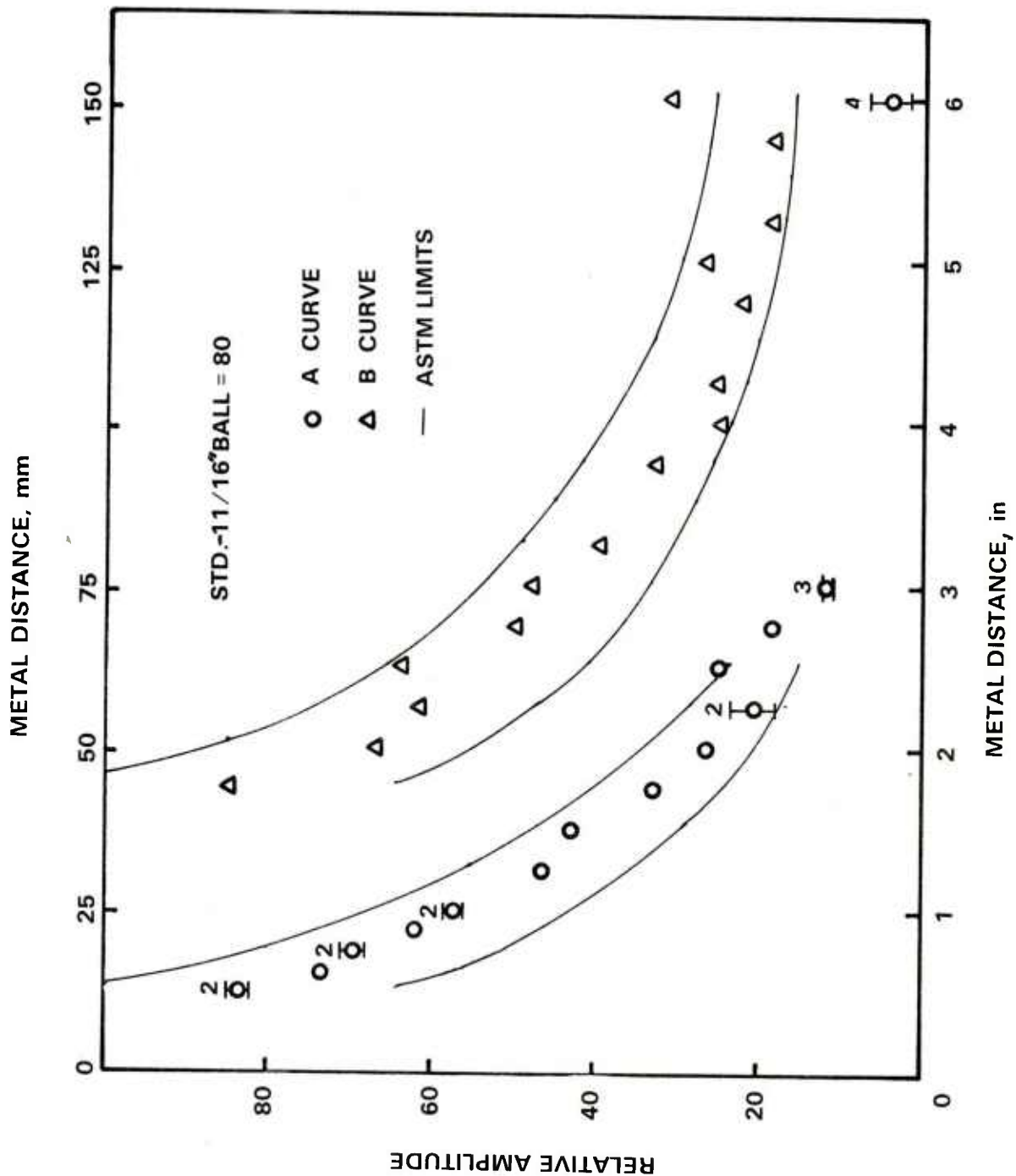

Fig. 14-DISTANCE-AMPLITUDE DATA FOR NO. 8 BLOCKS AT 5.0 MHz (QUARTZ)

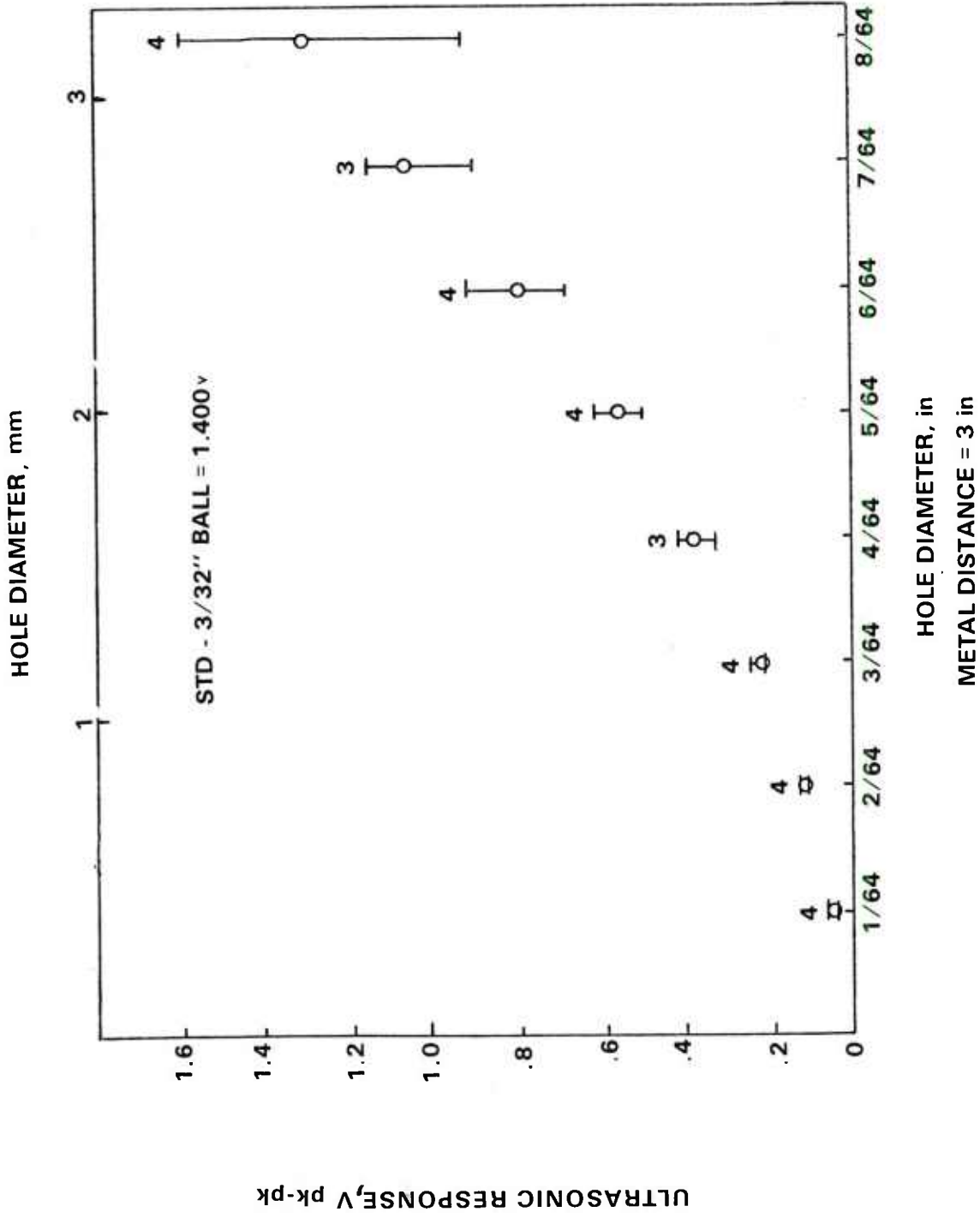

Fig. 15 - AREA-AMPLITUDE DATA AT 2.25 MH  $\tau$

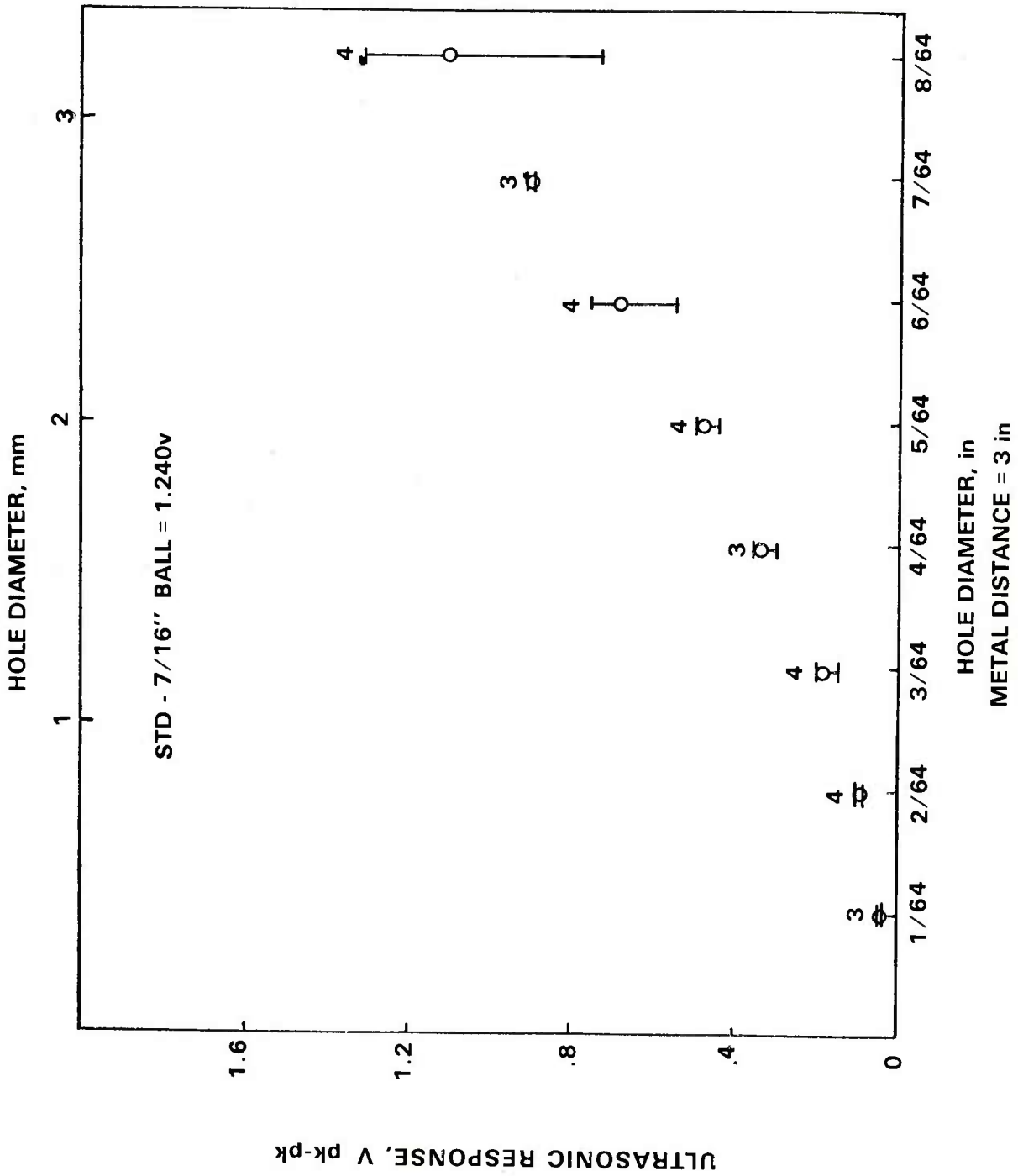

Fig. 16-AREA-AMPLITUDE DATA AT 5.0 MHz

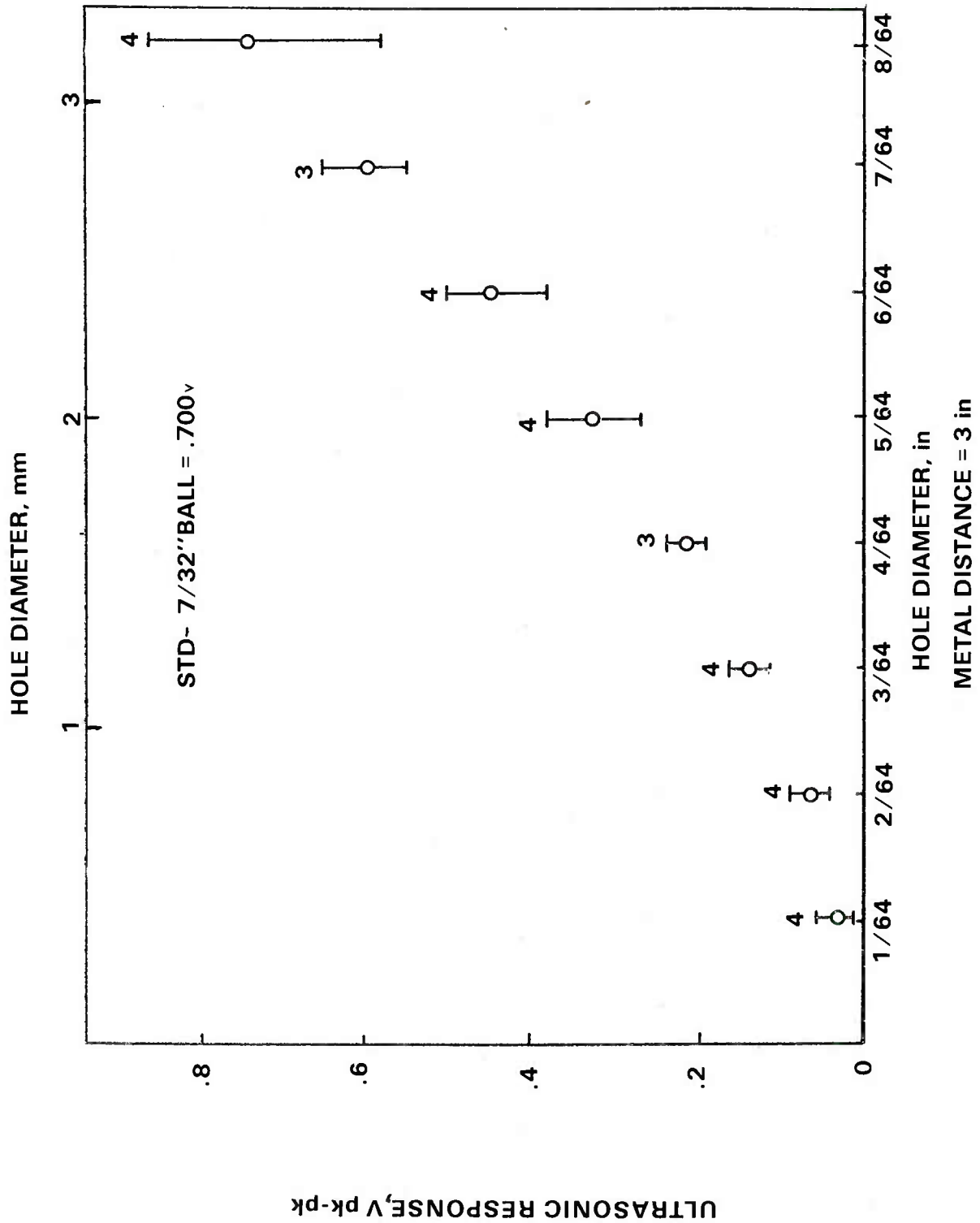

Fig. 17-AREA-AMPLITUDE DATA AT 10 MHz

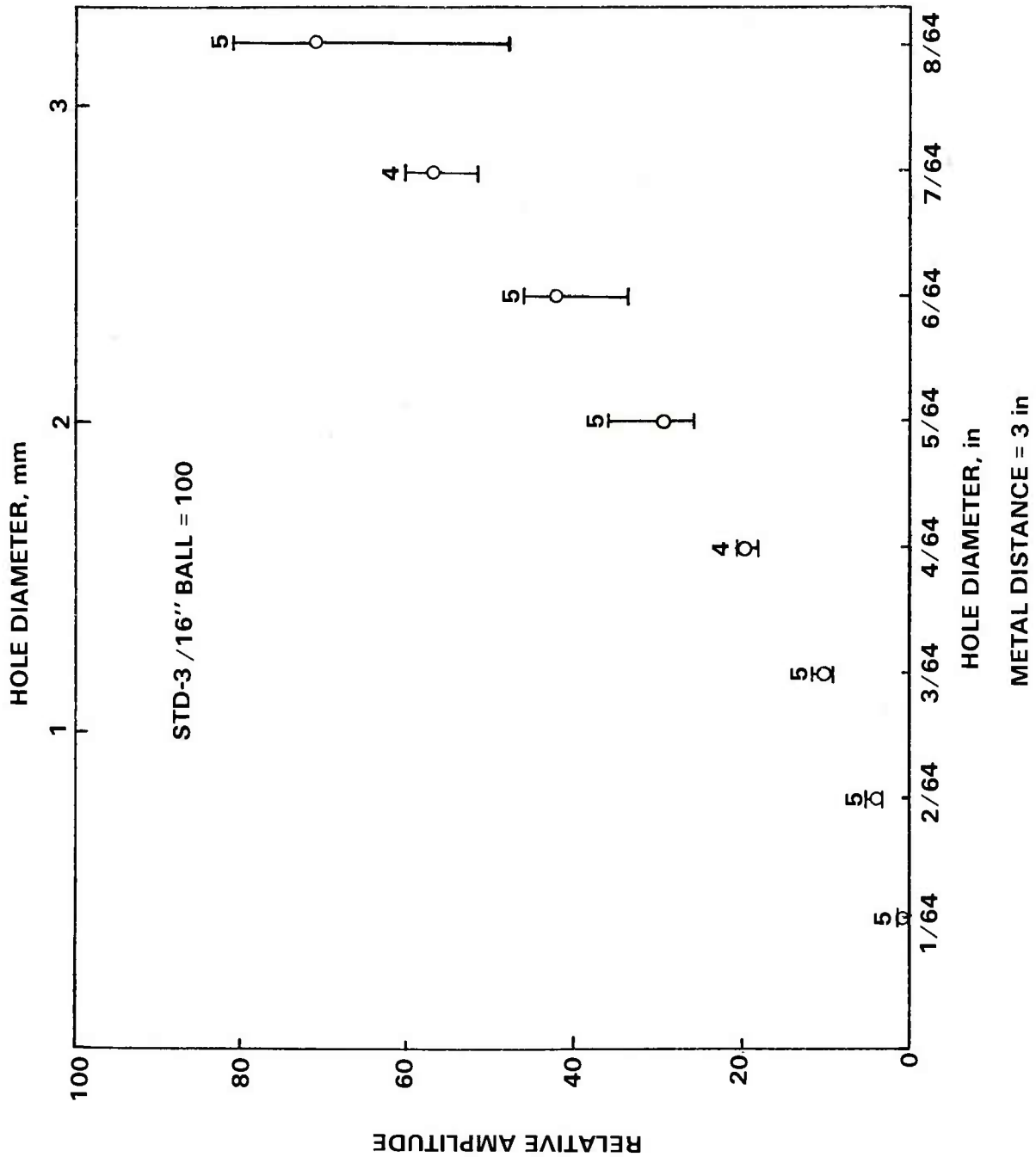

Fig. 18 - AREA-AMPLITUDE DATA AT 5.0 MHz (QUARTZ)

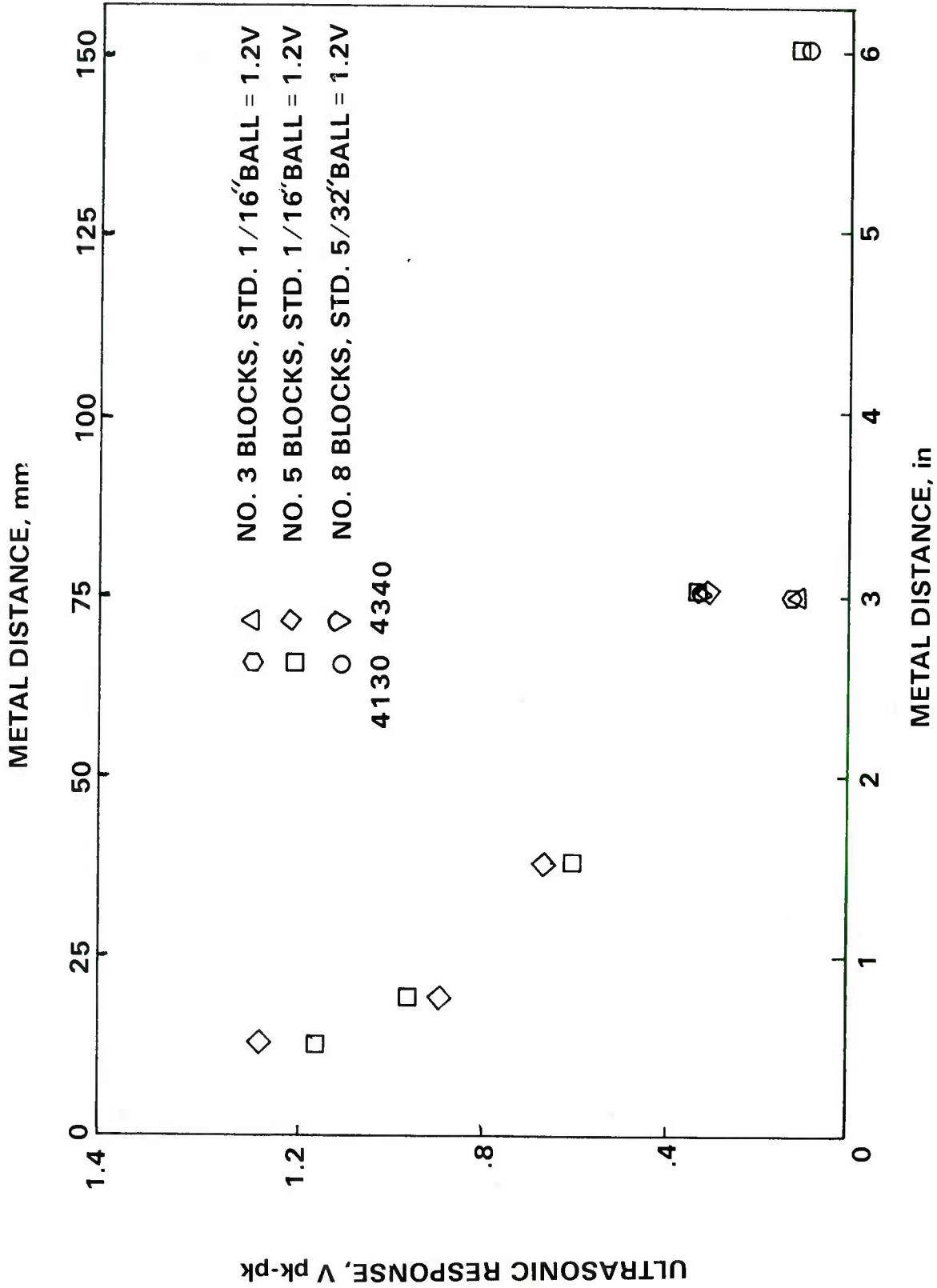

Fig. 19 - DISTANCE-AMPLITUDE DATA FOR STEEL BLOCKS WITH 2.25 MHz CERAMIC TRANSDUCER AND BROADBAND PULSER.

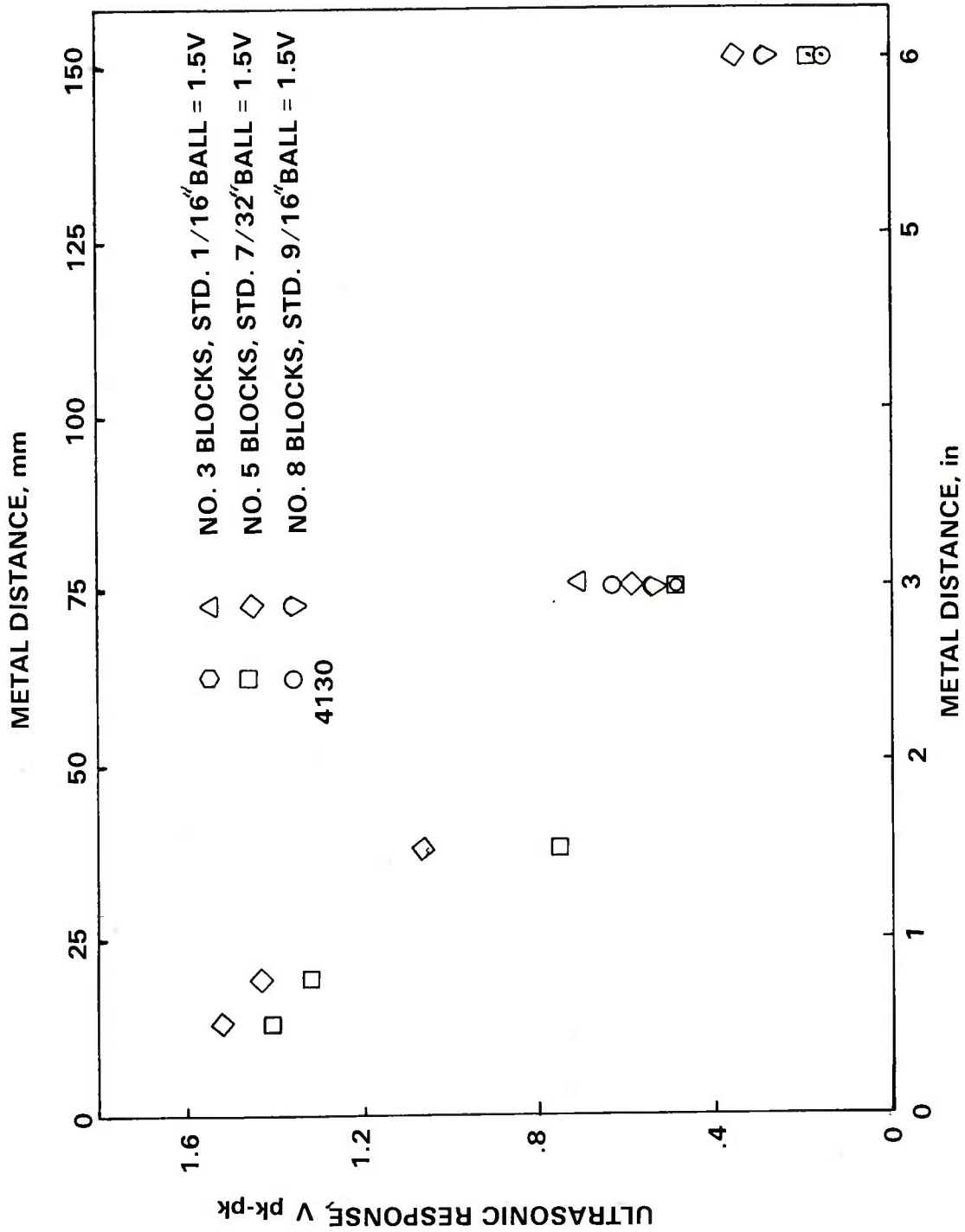

Fig. 20-DISTANCE-AMPLITUDE DATA FOR STEEL BLOCKS WITH 5 MHz CERAMIC TRANSDUCER AND BROADBAND PULSER.

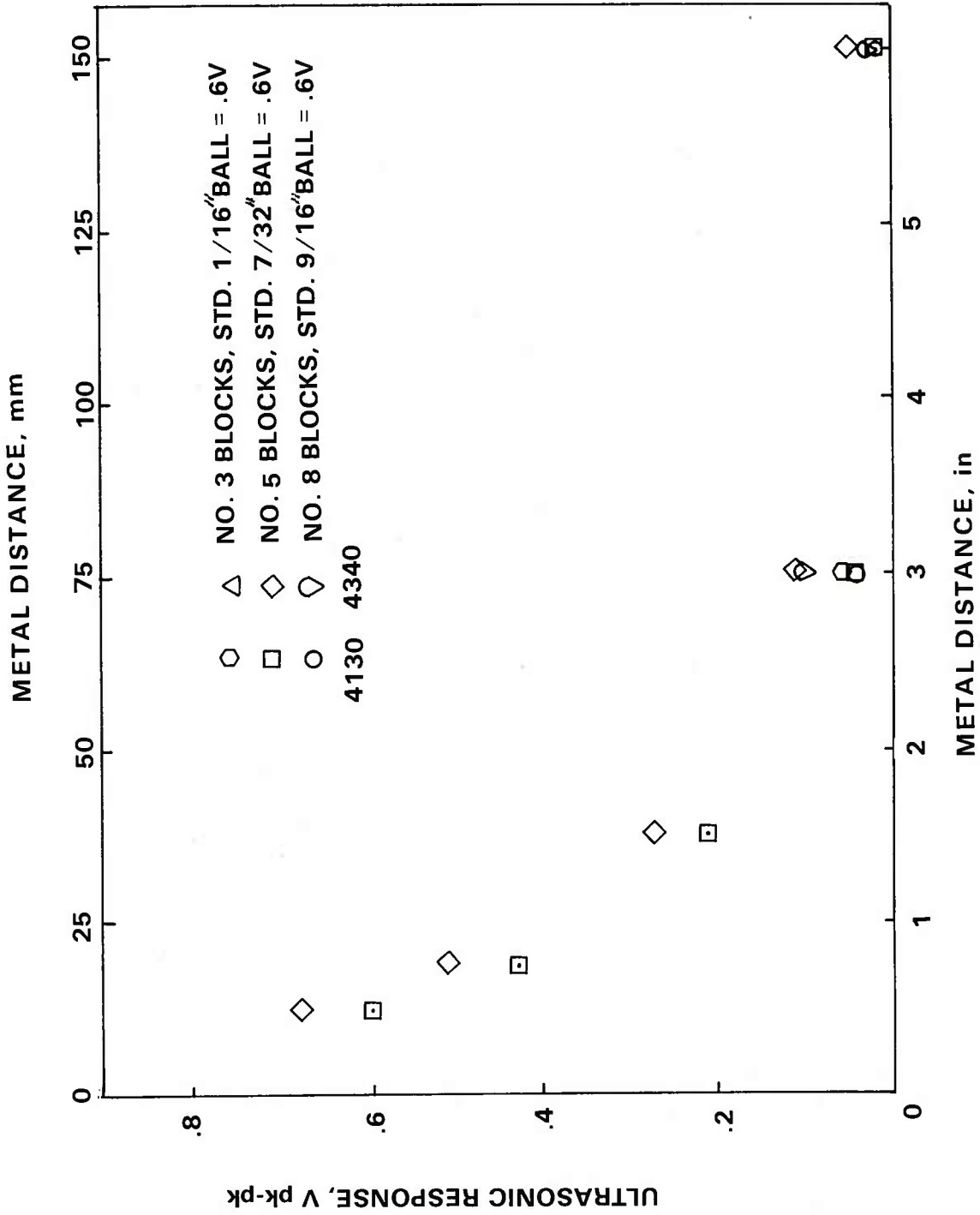

Fig. 21-DISTANCE-AMPLITUDE DATA FOR STEEL BLOCKS WITH 10 MHz CERAMIC TRANSDUCER AND BROADBAND PULSER.

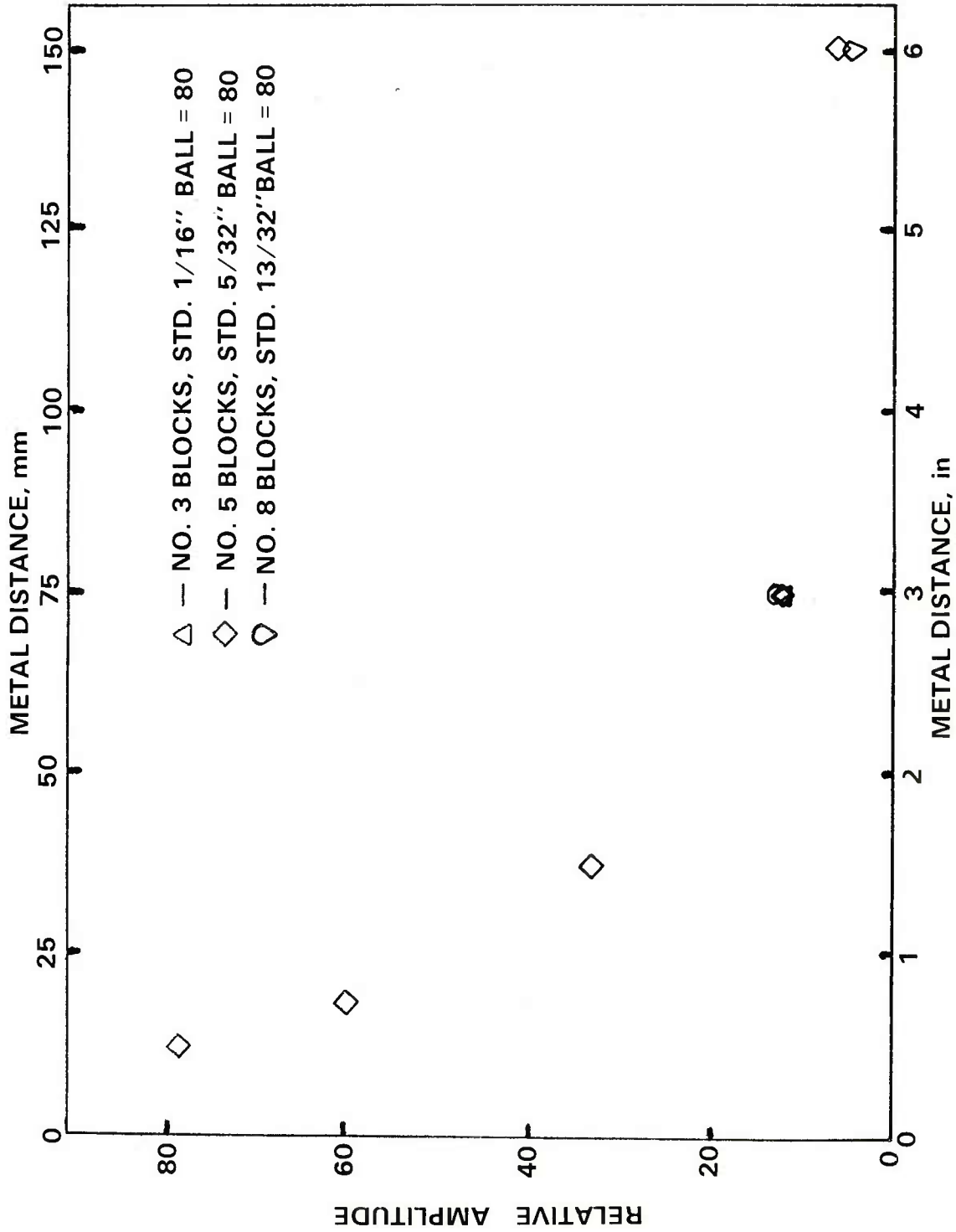

Fig. 22-DISTANCE-AMPLITUDE DATA FOR STEEL BLOCKS WITH 5 MHz QUARTZ TRANSDUCER AND TUNED PULSER.

The data presented in Figures 12, 13, and 14 were taken using the procedures and standardization points recommended in E 127-75 [3]. Note that there are several points that fall outside of the response limits of  $\pm 2$  dB around the desired value. This indicates that some of the problems associated with recommended practice E 127 were not resolved by the 1975 revision even within the large allowable tolerances. Clearly, a calibration procedure with a well defined unit or primary standard would resolve much of this problem.

A limited amount of data was also taken on titanium blocks. Two 2-piece, diffusion-bonded titanium reference blocks of the type described in [7] were examined. These blocks contained defects measuring 1, 2, 3 and 5-64 in (0.40, 0.79, 1.19, and 1.98 mm) in diameter. One of the blocks had metal travel distances of 0.25 and 2.75 in (6.4 and 69.9 mm) and the other block had metal travel distances of 1.50 and 1.50 in (38.1 and 38.1 mm). Data were taken with a 10 MHz, 0.25 in (6.4 mm) diameter transducer and the field-type flaw detection unit. Comparison of the amplitude response with dB attenuation differences were made. The results were inconsistent. Extraneous signals from the bond line severely affected the defect amplitude measurements on all but the 0.25 in (6.4 mm) metal travel block. Some of the noise was attributed to fabrication difficulties experienced in this early attempt at a diffusion bonding process. Others are still working on this technique, e.g. [11]. It is anticipated that reference blocks of this type will be more closely examined in future efforts at NBS. The technique seems to be particularly promising for steel and titanium reference blocks.

#### b. 7075-T651 Reference Blocks

Six production runs of ultrasonic reference blocks were made from a single lot of 7075-T651 extruded 2.25 in (57.15 mm) diameter rod material

supplied by NBS. This material was chosen over 7075-T6 rolled rod material because it was from a single lot and was readily available. Thus metallurgical variables were hopefully minimized. Three fabrication runs were made by machinists at NBS and one run each was made by machinists from the 3 leading block manufacturers. Each machinist was supplied with a drawing from the ASTM-E 127 document (Figure 1) and asked to produce blocks to the tolerances specified. Five of the 6 production runs consisted of No. 3, 5, and 8 blocks (2 each) with a 3.00 in (76.20 mm) metal travel. The sixth machinist was asked to produce No. 3, 5, and 8 blocks (4 each) with a metal travel of 2.25 in (57.15 mm), and No. 5 blocks (6 each) with metal travels of 0.50 in (12.7 mm), 3.00 in (76.20 mm), and 5.75 in (146.05 cm). The ultrasonic responses from these blocks were measured at nominal frequencies of 2.25, 5.0, 10.0 and 15.0 MHz. The average ultrasonic response from these blocks was approximately 17 percent lower than the average response from the field blocks that were inspected, presumably due to the slightly different metallurgy. The variation in response for the nominal frequencies of 2.25 and 5.0 MHz was about half that found in the field-type standards (see Table 5). These two factors point to the significance of the metallurgical aspects in improving the current reference standard, particularly the need for a uniform lot of homogeneous material from which to produce standards.

#### 4. Metallurgical Considerations

This task is concerned with the evaluation of the material from which ultrasonic reference blocks are fabricated. Of particular concern are the microstructural and metallurgical parameters that can affect the ultrasonic response of reference blocks. Correlations were sought between ultrasonic response anomalies and microstructural features. Techniques for residual

TABLE 5. VARIABILITY IN RESPONSE BETWEEN BLOCKS MADE FROM 7075-T651 EXTRUDED ROD

| Machinist      | HOLE SIZE |       |       |        |       |       |        |       |       |        |       |       |
|----------------|-----------|-------|-------|--------|-------|-------|--------|-------|-------|--------|-------|-------|
|                | 3-0300    |       |       | 5-0300 |       |       | 8-0300 |       |       | 8-0300 |       |       |
|                | Block     | Amp1  | Amp1  | Block  | Amp1  | Amp1  | Block  | Amp1  | Amp1  | Block  | Amp1  | Amp1  |
| A              | 1-3       | 80(a) | 80(a) | 1-5    | 80(a) | 80(a) | 1-8    | 80(a) | 80(a) | 1-8    | 80(a) | 80(a) |
| A              | 2-3       | 80    | 81.5  | 2-5    | 74    | 73    | 2-8    | 73    | 73    | 2-8    | 83.5  | 84.5  |
| B              | 1-3       | 73.5  | 74    | 1-5    | 80    | 80    | 1-8    | 80    | 80    | 1-8    | 82.5  | 82.5  |
| B              | 2-3       | 73    | 74    | 2-5    | 81.5  | 81    | 2-8    | 81    | 81    | 2-8    | 81    | 80.5  |
| R              | 1-3       | 80    | 80.5  | 1-5    | 73.5  | 73    | 1-8    | 73    | 73    | 1-8    | 78    | 78    |
| R              | 2-3       | 77.5  | 78.5  | 2-5    | 72    | 71.5  | 2-8    | 71.5  | 76    | 2-8    | 76    | 76    |
| S              | 1-3       | 83.5  | 84    | 1-5    | 77.5  | 77    | 1-8    | 77    | 84    | 1-8    | 83.5  | 84    |
| S              | 2-3       | 83    | 83    | 2-5    | 84    | 85    | 2-8    | 85    | 82    | 2-8    | 82    | 82    |
| T              | 1-3       | 80    | 80.5  | 1-5    | 75.5  | 75    | 1-8    | 75    | 82    | 1-8    | 82    | 82.5  |
| T              | 2-3       | 78.5  | 79    | 2-5    | 75.5  | 75    | 2-8    | 75    | 88    | 2-8    | 88    | 88    |
| TRANS (b)      | LS-4      | LS-3  | LS-3  | LS-4   | LS-3  | LS-3  | LS-4   | LS-3  | LS-4  | LS-3   | LS-4  | LS-3  |
| Avg.           | 78.9      | 79.5  | 79.5  | 77.35  | 77.05 | 77.05 | 81.65  | 81.65 | 81.65 | 81.8   | 81.65 | 81.8  |
| Spread         | 10.5      | 10    | 10    | 12     | 13.5  | 13.5  | 12     | 12    | 12    | 12     | 12    | 12    |
| Spread/Avg., % | 13.3      | 12.6  | 12.6  | 15.5   | 17.5  | 17.5  | 14.7   | 14.7  | 14.7  | 14.7   | 14.7  | 14.7  |

(b) Both LS-3 and LS-4 are 5 MHz, 0.375 in dia quartz transducers

(a) reading standardized at 80

stress measurements, preferred orientation measurements, and microstructural measurements were refined and applied in this task.

Aluminum, steel, and titanium alloys of the type used in reference block production were studied. Two reference blocks, one 7075-T6 aluminum alloy and one 4340 steel alloy, rejected by the manufacturer during fabrication, were closely examined. Additional work was done on an NBS fabricated block of 7075-T651 aluminum alloy and some titanium alloy (Ti 6-4) sheet material [8] and steel sheet material.

a. Aluminum Block

Studies were conducted of the microstructure of the extruded 7075-T651 aluminum block that was fabricated at NBS from commercial material. Several surfaces produced by sectioning the block were examined. Determinations of the void content and the inclusion content were made on metallographically polished surfaces prior to etching. Figure 23 shows one representative area on a polished surface with the voids and cavities appearing dark. From the shape of some of the voids they appear to have resulted either from original cavities forming at grain boundaries during solidification or possibly from later void growth at grain boundaries during fabrication. Another region on a different surface is shown in Fig. 24. The void density found in the NBS block was not significantly different from that found in the rejected aluminum block reported on previously [8]. Some foreign phases also were found on the sections examined. They are seen as lighter grey areas in Figs. 23 and 24. The frequency of their appearance in the NBS block also is comparable to that in the previously examined rejected aluminum block.

Two different etching treatments were applied to the various aluminum surfaces studied in order to reveal the microstructural detail. Figure



Fig. 23 NBS-fabricated aluminum block surface, as polished. M = 400X.



Fig. 24 Another surface on NBS-fabricated block. M = 400X.

25 is a region of one surface of the NBS block etched in a 10% NaOH solution for 3 minutes at 140° F (60°C). Figure 26 shows the results of a 5% HF etch for 10 sec. Either treatment brings out the grain boundary structures and further enhances the foreign phase regions. Grain size measurements were conducted using the intercept method. A value of 7.3 grain size (mean intercept 26  $\mu\text{m}$ ) was obtained on the NBS block which was not significantly different from the grain size value of 7.5 determined previously for the rejected block.

Electron beam microanalysis studies were conducted on surfaces from both aluminum blocks to determine whether compositional inhomogenieties could be detected. Figure 27 depicts a region on a polished surface of the NBS block. X-ray spectra were obtained from two different areas within this micrograph and are shown in Fig. 28. The copper peaks (arrow) in these two spectra are nearly equal indicating no significant difference in copper concentration in those two areas. Many other areas were visually examined with the same result. Line scan studies were also conducted in which the electron beam is scanned along a fixed line on the specimen surface and the X-ray signal is stored during repeated scans. The white line in Fig. 27 is such a scan line. The copper X-ray data corresponding to that line is shown in Fig 29. While a small gradient decreasing to the right is seen and is due to geometric factors, no significant local variation in copper concentration could be detected. Other areas scanned also failed to show any local concentration variations of significance in the NBS block.

The aluminum block surfaces were also examined in the etched condition for variations in X-ray emission. Figure 30 shows a region on the NBS block surface after etching for 10 sec. in 5% HF solution. The white line

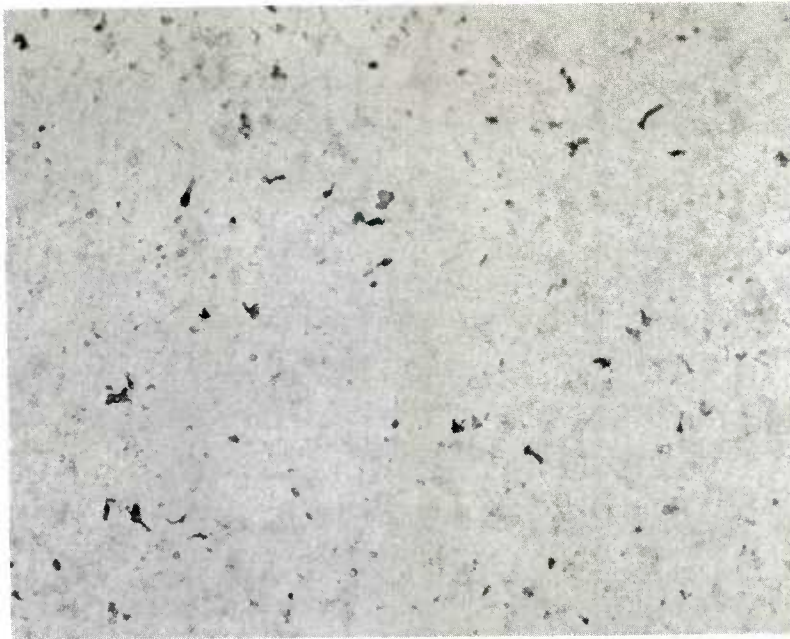

Fig. 25 NBS fabricated block etched in NaOH solution. M = 200X.

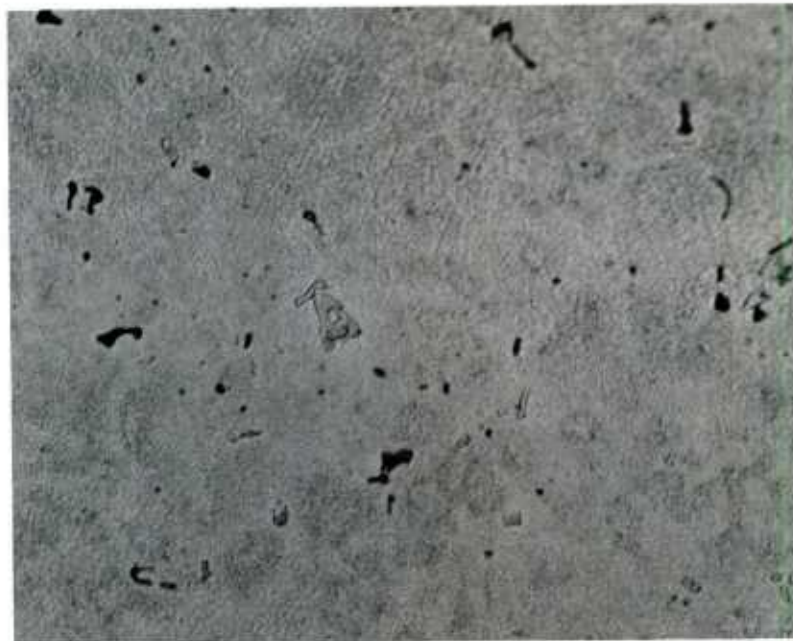

Fig. 26 Another surface on NBS fabricated block, etched in HF solution. M = 400X.



Fig. 27 NBS-fabricated block, as polished surface,  
X-ray scan trace location is shown. M = 140X.

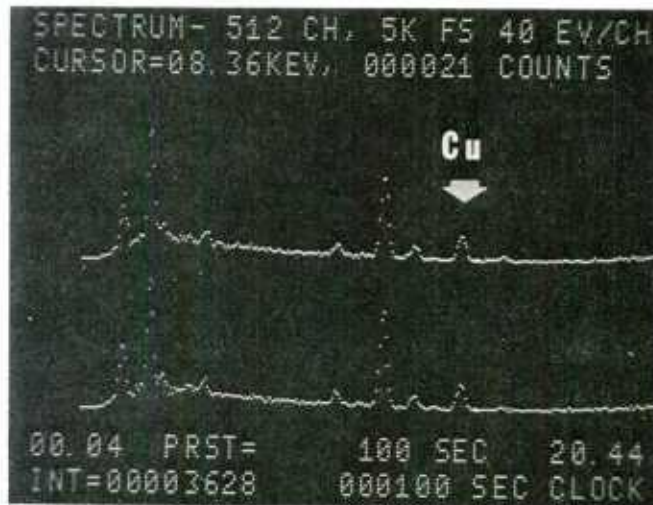

Fig. 28 X-ray spectra from two areas on surface shown  
in Fig. 27.

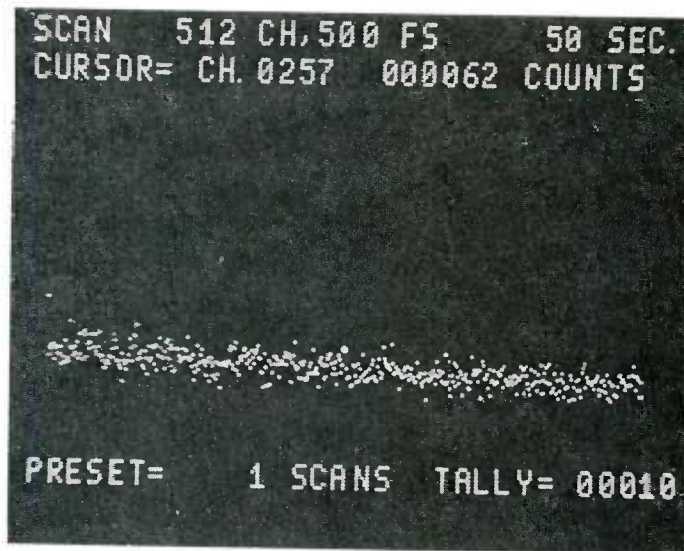

Fig. 29 Copper X-ray line intensity recorded along scan trace shown in Fig. 5. M = 110X.

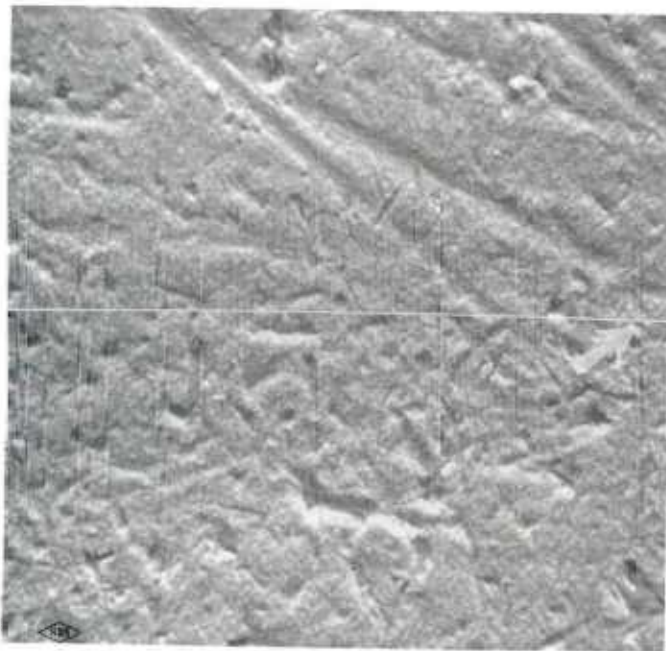

Fig. 30 Etched surface on NBS block. M = 1300X.

locates the line scan trace. The copper X-ray signal intensity obtained along this scan line is seen in Fig. 31. Some local variations in signal are seen and can be matched to scratches and etch topography on the surface rather than to actual copper concentration variations. The rejected aluminum block was also examined in the line scan mode after etching in the HF solution. The area is shown in Fig. 32. The nonuniform etching response is seen here; small patches of smooth surface are to be found (arrow). Some cavities can also be seen in this area. Figure 33 shows the X-ray signal from two different line scan regions on this surface -- one where the etched topography is uniform (upper) and the other where a smooth slightly etched region is included in the scan line (lower). A clear signal disruption is seen there, partially due to a variation in copper content. This block had previously been found to have etching characteristics interpreted to result from composition variations resulting from the solidification process.

Studies on the texture (crystalline preferred orientation) of the rejected aluminum block were reported previously in [8] will not be repeated here. Texture studies were made on one of the blocks made at NBS from extruded aluminum rod on surfaces S1 and S5/2, Fig. 34. Those measurements were made using filtered copper radiation and the 200, 111, and 220 peaks. The (100) pole figures for these two surfaces are included in Figs. 35 and 36. There is a variation in the decrease of intensities in these two pole figures indicating some lack of uniformity in the texture along the block. The texture of these pole figures showed the rotational symmetry usually found in a fiber structure. That is, the intensity levels occur in bands around the center. The intensities on these pole figures are

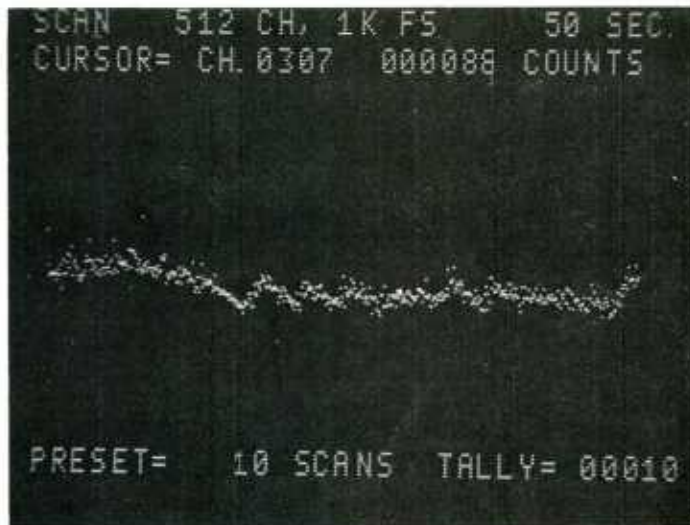

Fig. 31 Copper X-ray line intensity recorded along scan track shown in Fig. 8. M = 1050X.



Fig. 32 Etched surface of rejected aluminum block. Note smooth local regions (arrow). M = 1300X.

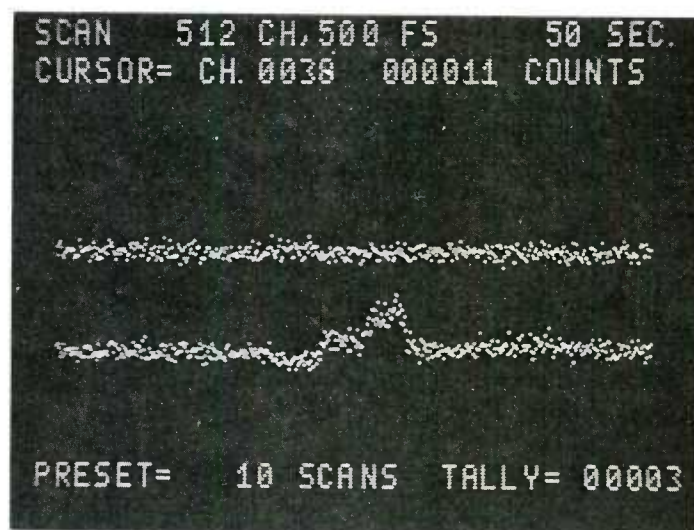

Fig. 33 Copper X-ray line intensity recorded along two lines in different regions on etched rejected aluminum block. Note large signal anomaly in lower trace. M = 1600X.

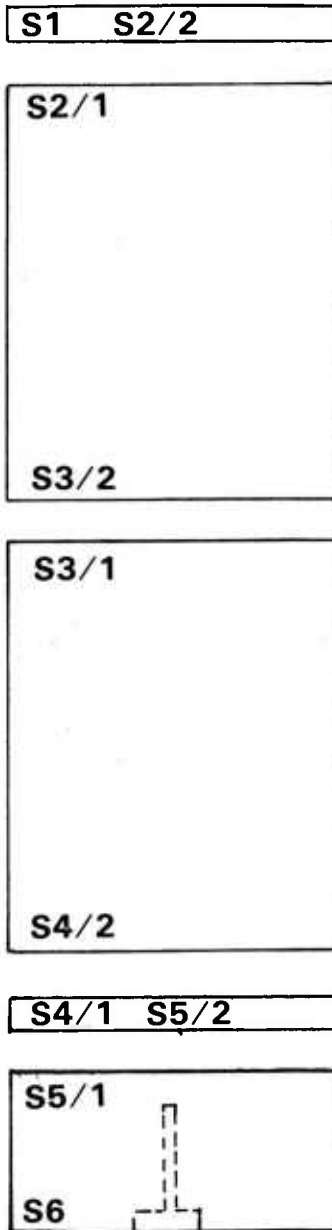

Fig. 34 SECTIONED NBS ALUMINUM BLOCK

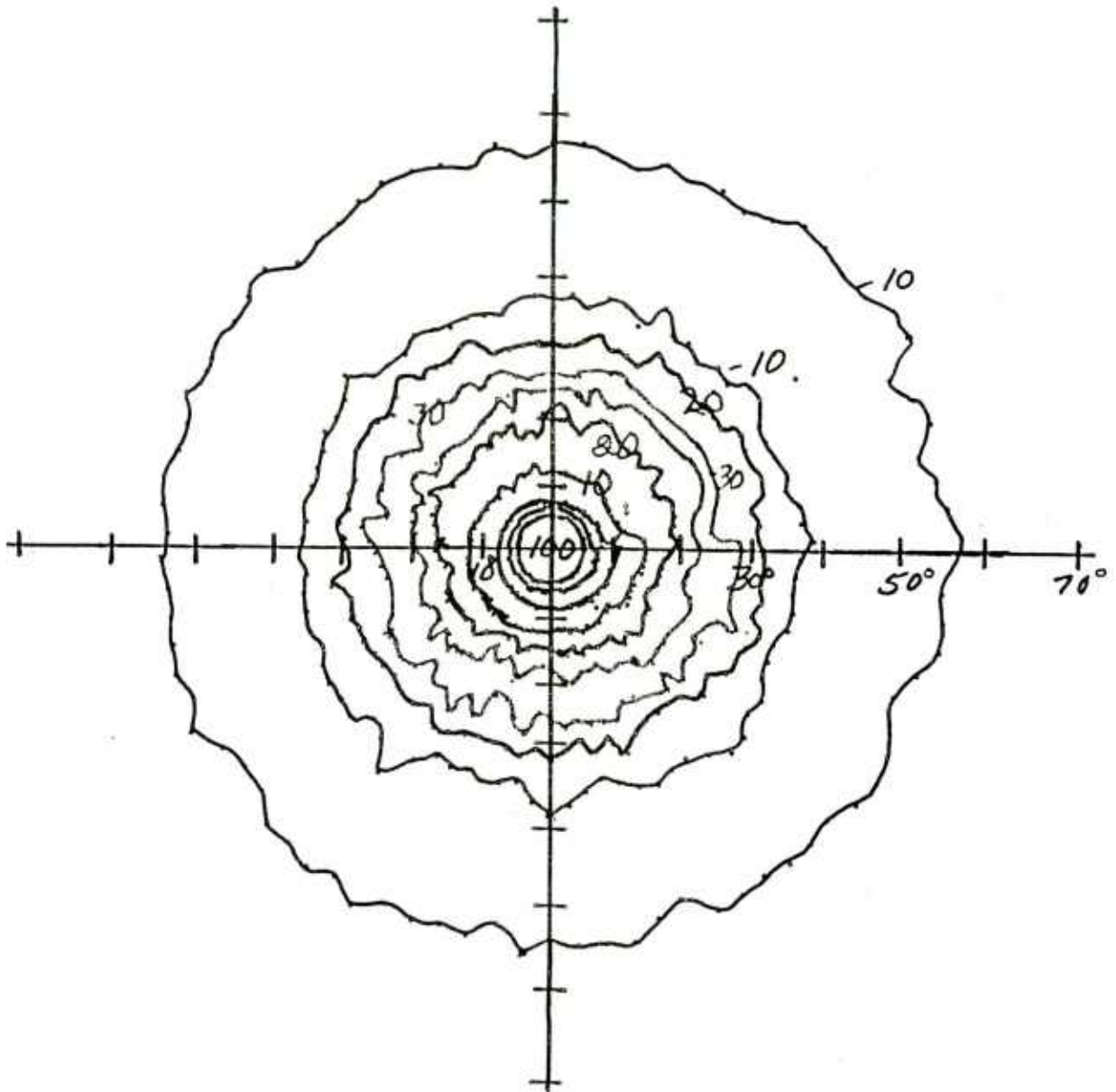

Fig. 35. NBS Al Block Surface S5/2 (100) pole.  
Intensity at center 100.

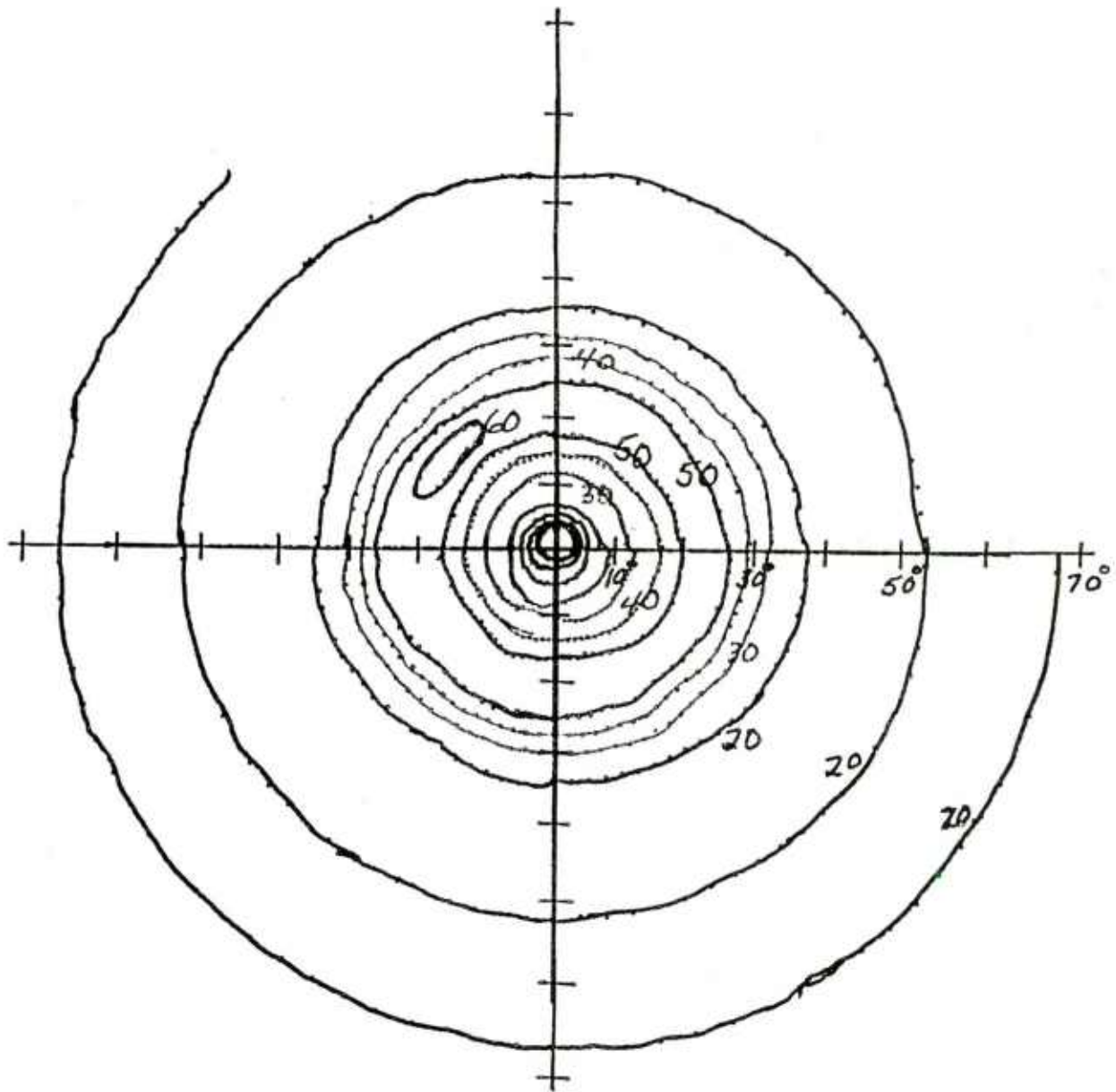

Fig. 36 NBS Block Surface S1 (100) pole. Maximum intensity at center - 100.

plotted on a relative scale of 0 to 100, the strongest intensity being assigned the value of 100.

The (100) pole figures have the maximum intensity in the center, with a rapid decrease within  $10^\circ$  from the center. A secondary maximum band is reached at approximately  $20^\circ$  from the center. The (100) pole figure of the S5/2 surface showed a more pronounced variation in intensity than did the (100) pole figure from the surface (S1). The (111) pole figure, Fig. 37, showed a minimum at the center with maxima occurring near  $35^\circ$  and  $55^\circ$ . The maximum at  $55^\circ$  is related to the strong (100) texture of that surface. The (110) pole figures, Fig. 38 and 39, showed a broad maximum band between  $20^\circ$  and  $55^\circ$  with a crest near  $30^\circ$ . The occurrence of that crest near  $30^\circ$  for the (110) pole and the secondary maxima near  $35^\circ$  for the (111) pole and near  $20^\circ$  for the (100) pole implies that the rod has an additional texture component near (113) to (114). The observed rotational symmetry is to be expected for an extruded rod. The detailed texture features depend on properties such as grain growth in the ingot, alloy composition, temperature of extrusion, and the applied thermal and mechanical treatments. Face centered cubic metals and alloys show varied strong texture types from (100) to (111) components.

The texture of the rejected block, made of rolled rod, that was previously studied, was characterized by an absence of rotational symmetry. The (111) pole figure of that block (Fig. 20, [8]) showed evidence of four-fold symmetry which was probably retained from the early fabrication of the rolled rod. The same uniformity in texture as found in extruded rod is not to be expected in swaged or rolled rod. From texture consideration, an extruded rod would probably give a more uniform response

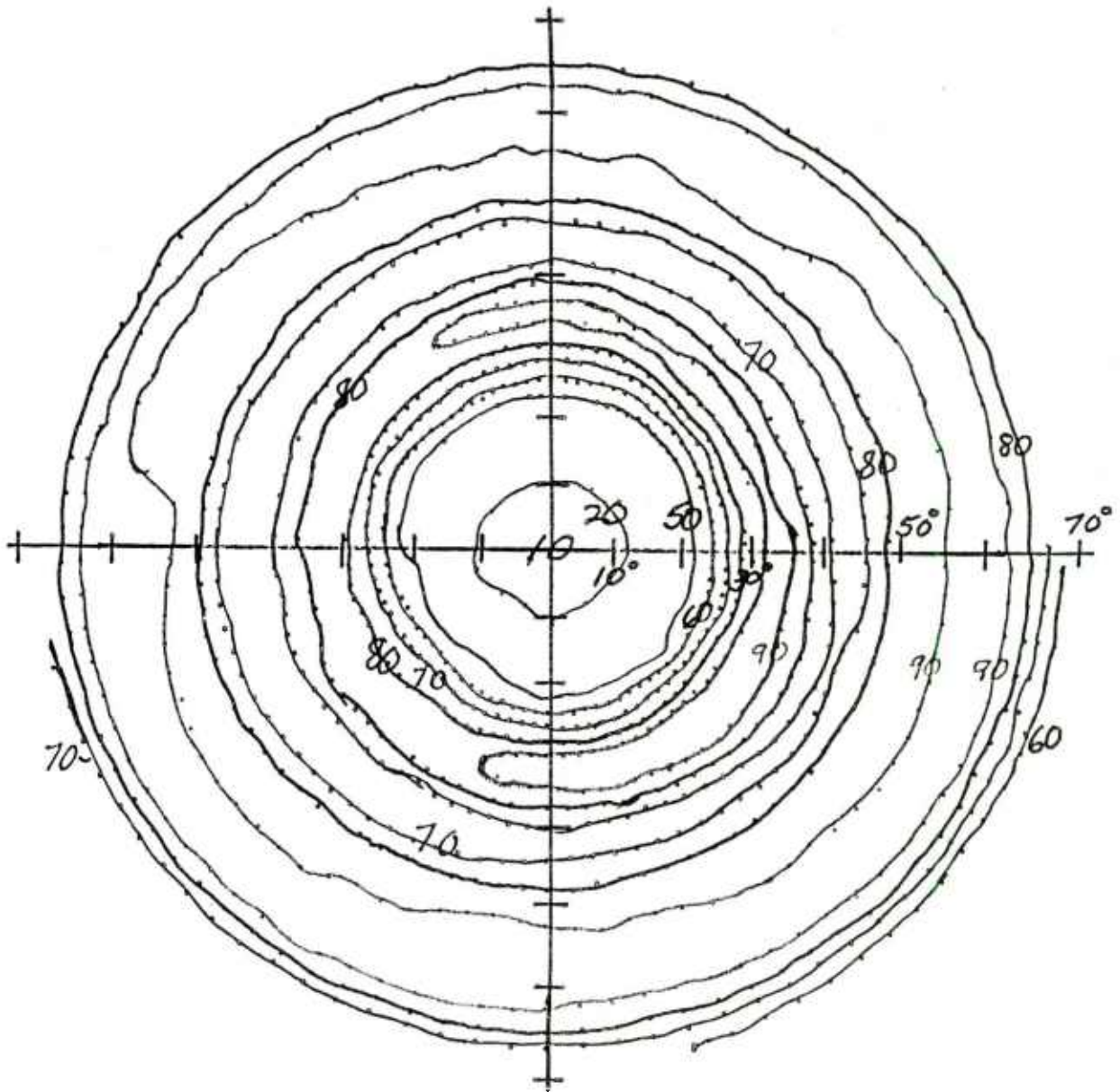

Fig. 37 NBS Block Surface S1 (111) pole.

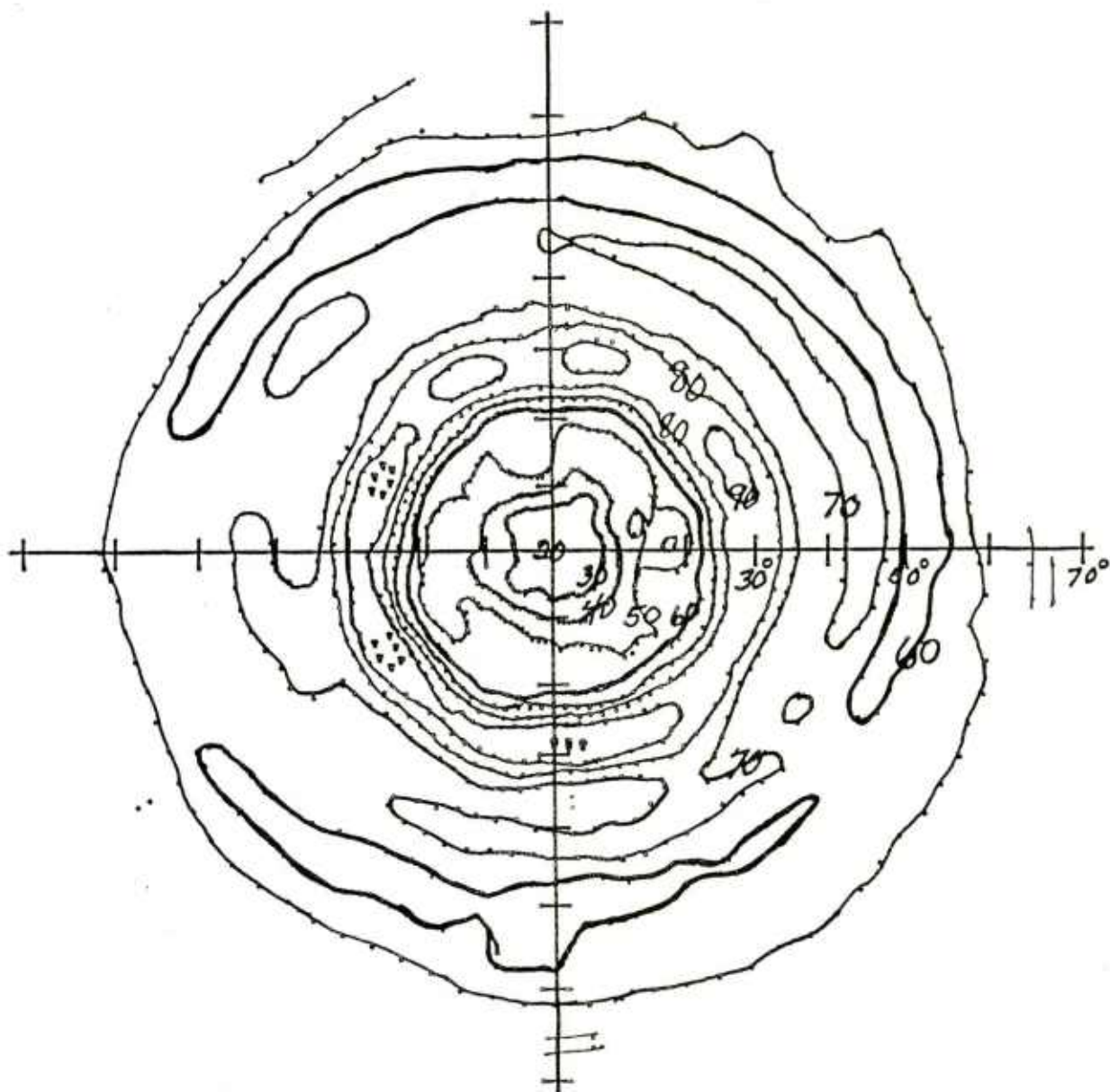

Fig. 38 NBS Block Surface S5/2 (110) pole. Intensity at center  $2\theta$ .

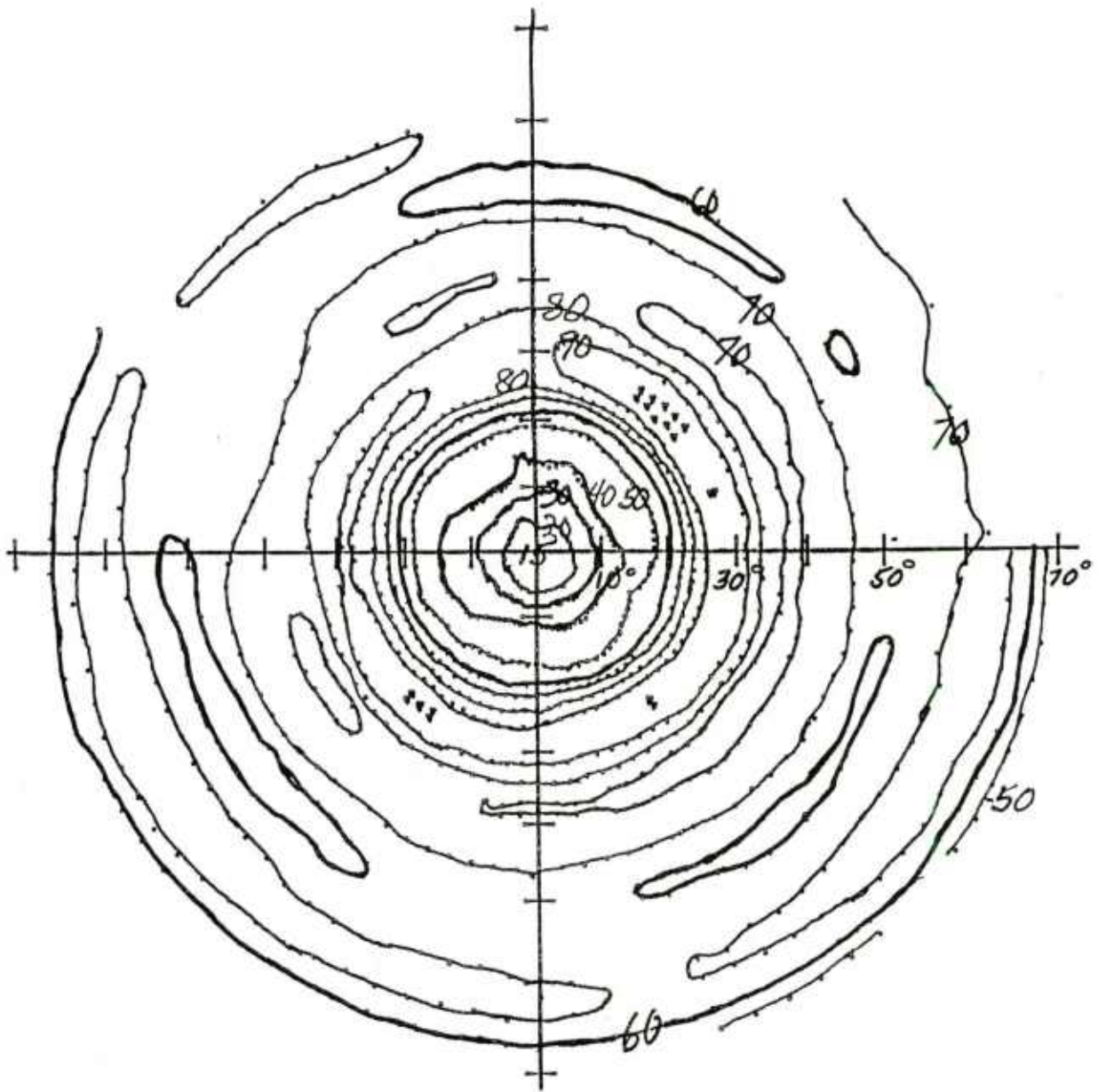

Fig. 39 NBS Block Surface S1 (110) pole. Intensity at center 15.

in ultrasonic attenuation than a rolled rod. As ultrasonic attenuation is effected by crystal orientation, this texture would introduce variations in the ultrasonic response through the block.

Residual stress measurements were made on surfaces S4/1 and S5/2 (Fig. 34) as metallographically polished and after etching for three minutes in hot( 140-149°F (60-65°C))10% NaOH solution. The compressive stress on the two surfaces after metallographical polishing was  $26.1 \times 10^3$  lbf/in<sup>2</sup> ( $1.8 \times 10^8$  Pa). After etching the values decreased to 6.2 and  $6.8 \times 10^3$  lbf/in<sup>2</sup> ( $0.43$  and  $0.47 \times 10^8$  Pa) (see Appendix 1). This indicates that the stress in the interior of the block is relatively low. The T-6 precipitation anneal would be expected to reduce the quenching stresses in the 7075 alloy and the reduction is dependent on the temperature and the time of the anneal.

#### b. Steel Block

The rejected steel block was also examined metallographically. A 5% nital etch was used for 15 seconds. The observed structure on the original surface containing the plugged hole is shown in Fig. 40. Several void and cavity features are seen in this area. A higher magnification view of an interior (cut) surface from the steel block is shown in Fig. 41. Two large grains can be identified, although the remaining grains in this field are considerably smaller. However, even the few large grains found contained an internal fine second phase structure that probably produced a much smaller "effective" grain size. The interparticle separation was about 1  $\mu$ m in the steel specimen even though grains larger than 20  $\mu$ m could be identified. It appears that the microstructure of the steel block material is sufficiently fine grained for it to behave ultrasonically in a fairly homogeneous manner. The ultrasonic examination of this block prior to sectioning did not reveal



Fig. 40 Steel block, surface containing hole plug, after nital etch. M = 160X.



Fig. 41 Steel block, interior surface, after nital etch. M = 800X.

any anomalies even though it was obtained after rejection for reference block purposes.

Texture measurements were made on surfaces S1 and S5/2, Fig. 42 of the rejected steel block. Intensities were taken using the 111, 200, 211, and 220 peaks with filtered molybdenum radiation and a standard texture goniometer. The intensities were relatively constant with orientation showing less than ten per cent variation. These results indicate that the rejected steel block had essentially a random orientation texture. Sample intensities for the S5/2 surface are shown in Table 6.

TABLE 6 TEXTURE MEASUREMENT INTENSITIES ON THE S5/2 SURFACE OF THE REJECTED STEEL BLOCK.

| Tilt<br>Angle<br>(deg) | Intensities for<br>Various Poles |        |       |
|------------------------|----------------------------------|--------|-------|
|                        | (110)                            | (200)  | (211) |
| 0                      | 100.0                            | 96.2   | 98.5  |
| 5                      | 92.5                             | 95.0   | 98.5  |
| 10                     | 95.0                             | 97.5   | 100.0 |
| 15                     | 91.3                             | 93.7   | 98.5  |
| 20                     | 93.7                             | 100.00 | 100.0 |
| 25                     | 87.5                             | 95.0   | 93.8  |
| 30                     | 93.7                             | 100.0  | 98.5  |
| 35                     | 81.2                             | 93.7   | 90.8  |
| 40                     | 93.7                             | 96.2   | 96.9  |
| 45                     | 75.0                             | 93.7   | 90.8  |
| 50                     | 85.0                             | 95.0   | 87.7  |

The [110] texture was essentially constant for both surfaces. A [110] texture is normally expected for bcc rod or wire materials.

#### Steel Block - Residual Stress

Residual stress measurements on the rejected steel block were made as outlined in SAE TR-182 (amended)[12]. The determination of the peak maximum is done differently. The alpha-1 peak is separated by using a modified method to that outlined by Gangulee [13]. The new points are fitted to a parabola and the parabola maximum is taken as the peak position. For this rejected steel block, the 211 diffraction peak was measured with monochromatic

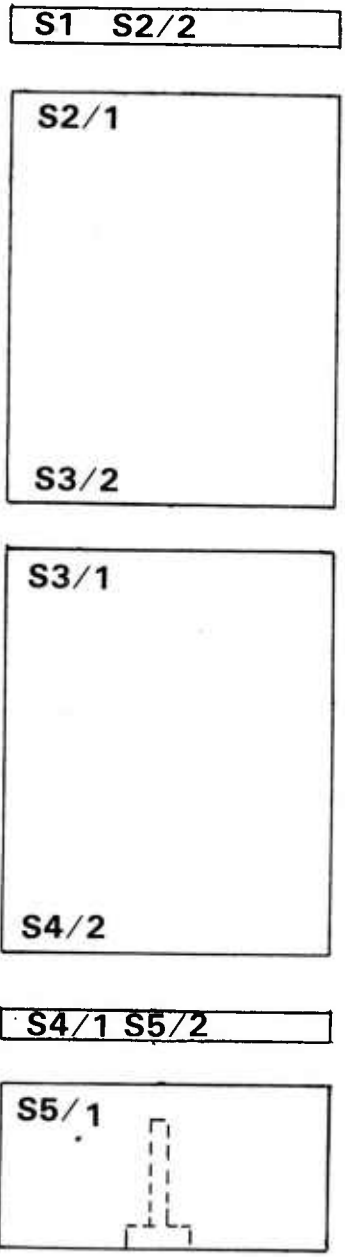

Figure 42. SECTIONED REJECTED STEEL BLOCK

chromium radiation using a graphite crystal. The diffractometer was scanned across the two-theta region of interest at the rate of one degree in two-theta over a period of 240 seconds. Counts were taken at 20 second intervals with a scalar containing a memory, permitting a new count to start while the previous count was recorded on tape. As the steel block was essentially random in texture, no difficulty was encountered in getting sufficient intensities at all angles. The residual stress results are shown in Table 6 and with more detail in Appendix 2 for the various surfaces and conditions. Deeply etched or electropolished surfaces showed that the residual stress approached zero, indicating that the steel block was in the annealed condition. The results (Table 7) show that the stresses on the surface are affected by block history. The results on the etched specimens may be effected by the relaxation of stress on the roughened surfaces. The electropolished specimen retained a smooth surface and therefore was not subject to this problem. For some specimens, on slight electropolishing, a tensile stress appeared for angle values approaching  $60^\circ$  inclination where X-ray penetration is less, while intermediate angle values showed a compressive stress (Appendix 2).

Surface S1 in the as received condition showed considerably lower stress than surfaces S4/1 and S2/1 in the machined condition. After etching surface S1 with a nital solution, it was repolished on silicon carbide paper (through the 600 grit). The surface S1 in this condition showed the highest compressive stress measured.

Hardness measurement also were made on the S2/1 surface and were found to be approximately HRA 61 (Rockwell Scale A). Results are given in Table 8.

TABLE 7. RESIDUAL STRESS VALUES FROM THE SECTIONED STEEL BLOCK

| Location | <u>Residual<br/>Stress, Pa</u> | <u>Stress<br/>Deviation</u> | <u>Remarks</u>            |
|----------|--------------------------------|-----------------------------|---------------------------|
| S1       | -2.2 x 10 <sup>8</sup>         | 2.6 x 10 <sup>7</sup>       | As received               |
|          | -4.1                           | 1.8                         | Met. papers               |
|          | -2.4                           | 0.6                         | Polished                  |
|          | -0.77                          | 1.4                         | Polished and etched .001" |
|          | -0.35                          | 1.3                         | Electropolished .002      |
| S2/2     | -3.1                           | 0.7                         | Polished                  |
|          | 0.08                           | 1.1                         | Etched .001"              |
|          | -0.03                          | 1.2                         | Electropolished .002"     |
| S2/1     | -3.5                           | 1.9                         | Machined                  |
| S3/2     | -2.6                           | 0.5                         | Polished                  |
|          | -2.6                           | 1.9                         | Etched, nital             |
| S4/1     | -3.8                           | 2.7                         | Machined                  |
|          | -2.9                           | 2.2                         | Polished                  |
|          | 0.3                            | 2.9                         | Electropolished .001"     |
|          | -0.1                           | 0.8                         | Electropolished .0018"    |
| S5/2     | -2.1                           | 1.3                         | Polished                  |
|          | -0.1                           | 1.7                         | Electropolished .001"     |
|          | -0.6                           | 1.3                         | Electropolished .0018"    |

TABLE 8 HARDNESS MEASUREMENTS FROM THE S2/1 SURFACE OF THE REJECTED STEEL BLOCK.

---

| Distance from<br>Edge | HRA            |
|-----------------------|----------------|
| 1/8"                  | 60 3/4, 61 1/4 |
| 1/4"                  | 60 3/4, 61     |
| 3/8"                  | 60 3/4         |
| 1/2"                  | 61             |
| 5/8"                  | 61             |
| 3/4"                  | 61             |
| 7/8"                  | 61             |
| Center                | 61             |

---

These results also indicate that the steel block was in a soft, annealed condition, uniformly through the cross section.

Measurements were also made on some specimens cut from a 4130 type rolled steel sheet in order to indicate the texture that could be expected in that form of material. The specimens were examined as rolled and after the removal of various thicknesses of material by electropolishing. The results showed a strong preferred orientation in the plane of the sheet, in contrast to the random texture found in the steel block (rod) just discussed. The pole figures after different treatments are shown in Figs. 43-50.

#### 5. Fabrication Considerations

Two areas related to the fabrication of reference blocks were studied. The first area was concerned with the problem of meeting the appropriate physical dimensions and machining tolerances. The specifications in ASTM E 127 served as a reference. Specific help was requested from the Dimensional Technology and the Optics and Micrometrology Sections of NBS in the measurement of hole diameter, corner radius of the hole bottom,

Fig. 43 4130 Steel sheet, (110) pole,  
as rolled.

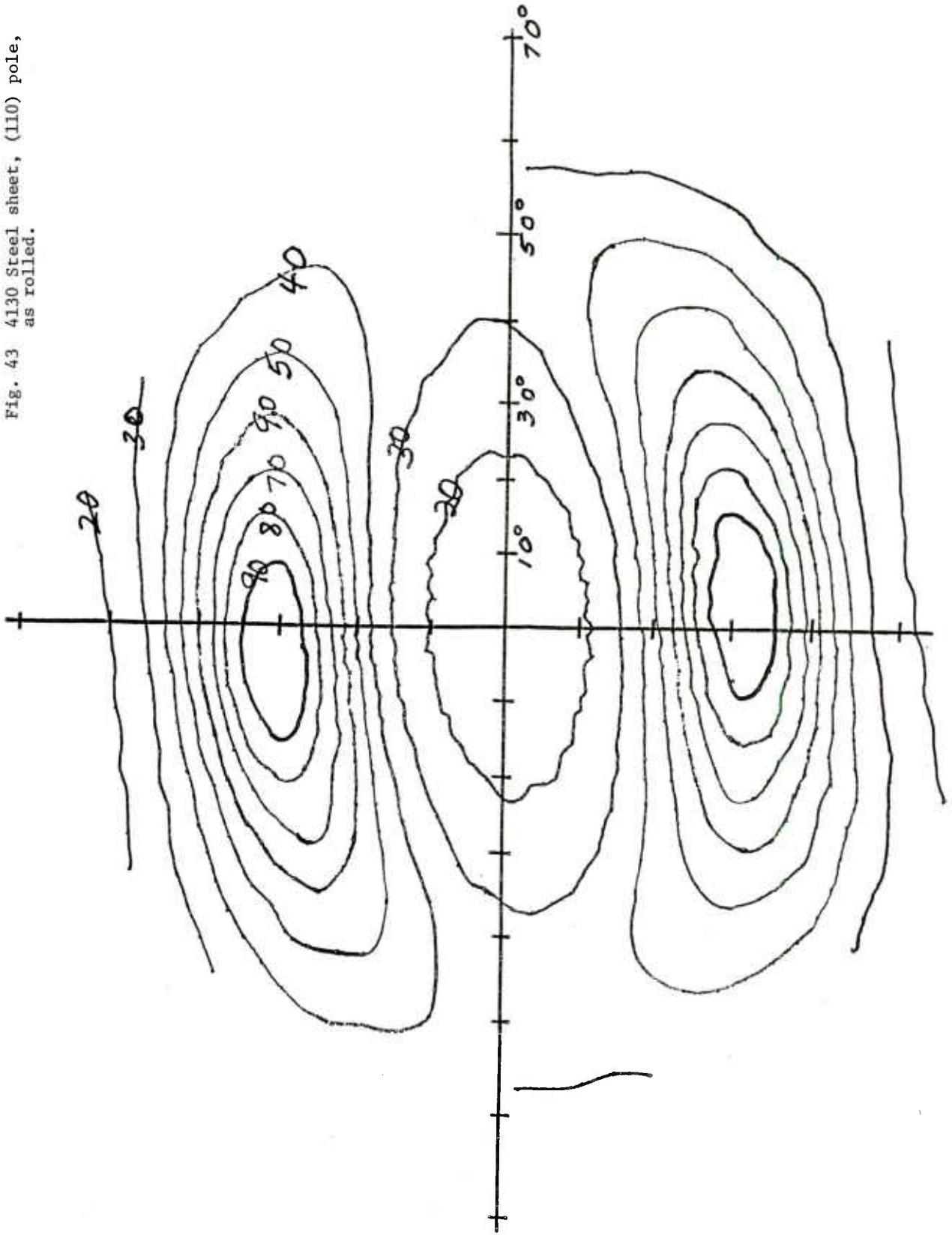
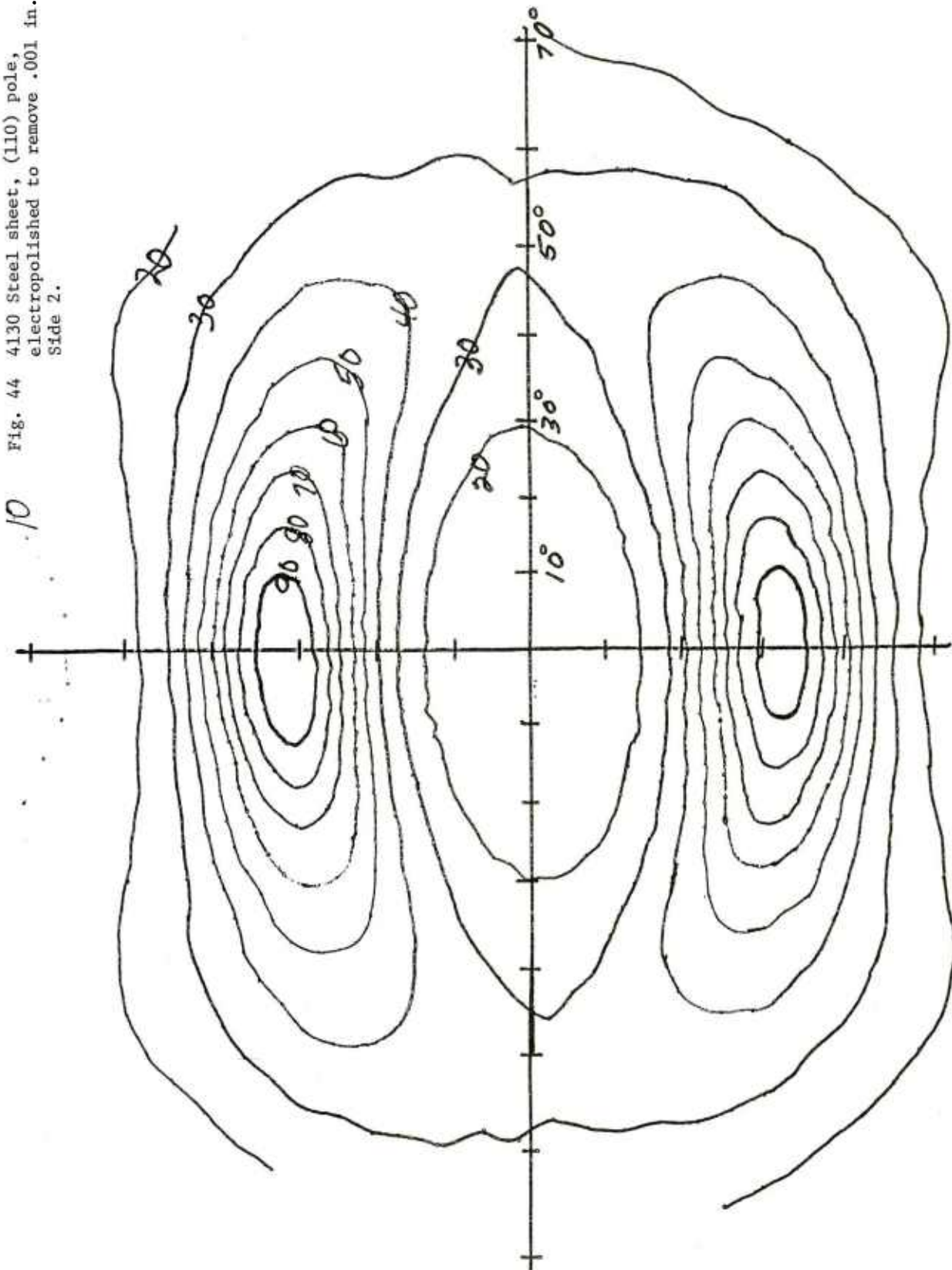
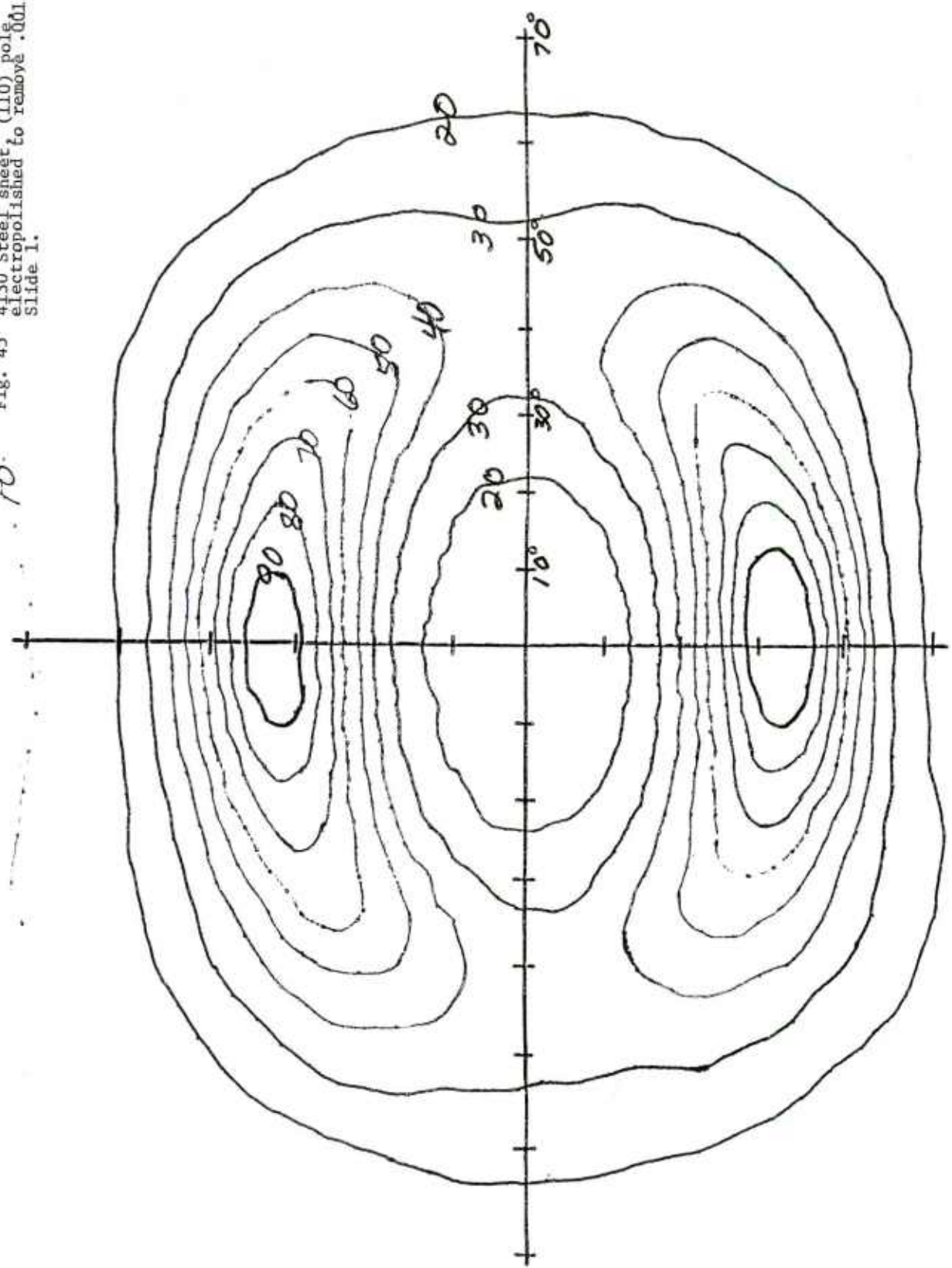

Fig. 44 4130 Steel sheet, (110) pole,  
electropolished to remove .001 in.,  
Side 2.



10. . . . . Fig. 45 4130 Steel sheet, (110) pole  
electropolished to remove .001 in.,  
Slide 1.



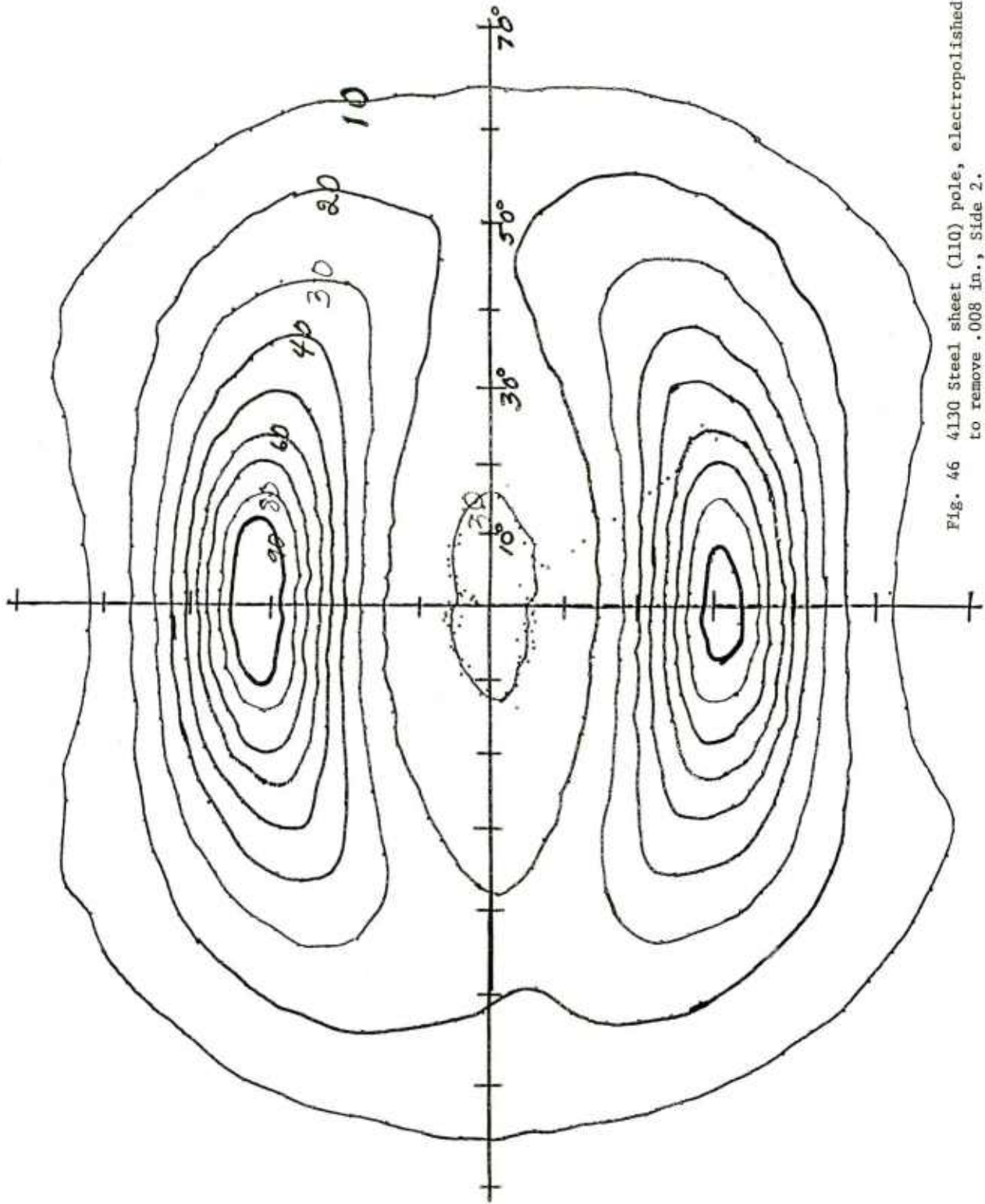

Fig. 46 4130 Steel sheet (110) pole, electropolished to remove .008 in., Side 2.

Fig. 47 4130 Steel sheet, (110) pole, combined transmission and reflection, specimen .002 in. thick, intensity times random.

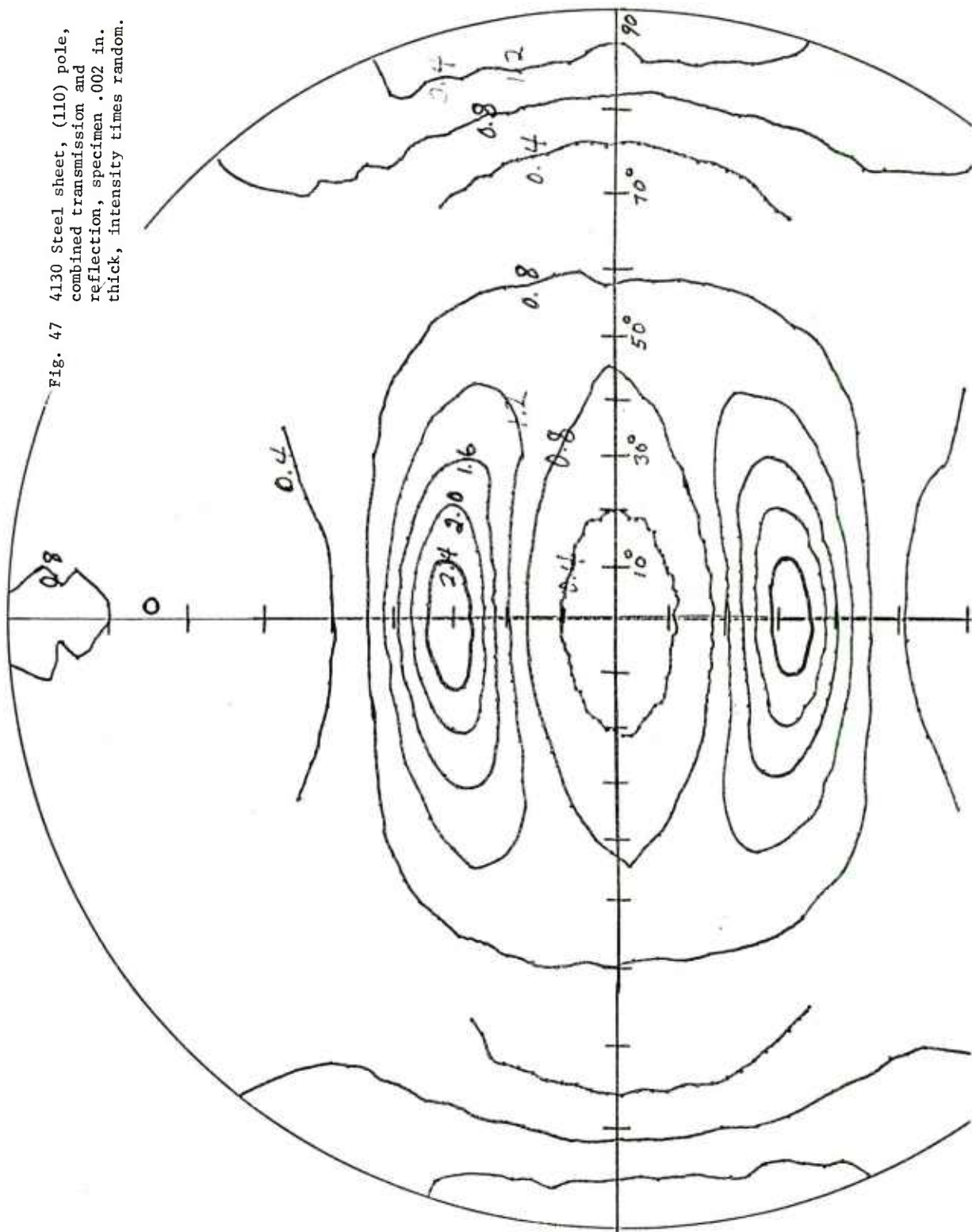

Fig. 48 4130 Steel sheet, (200) pole,  
electropolished to remove .008  
in.

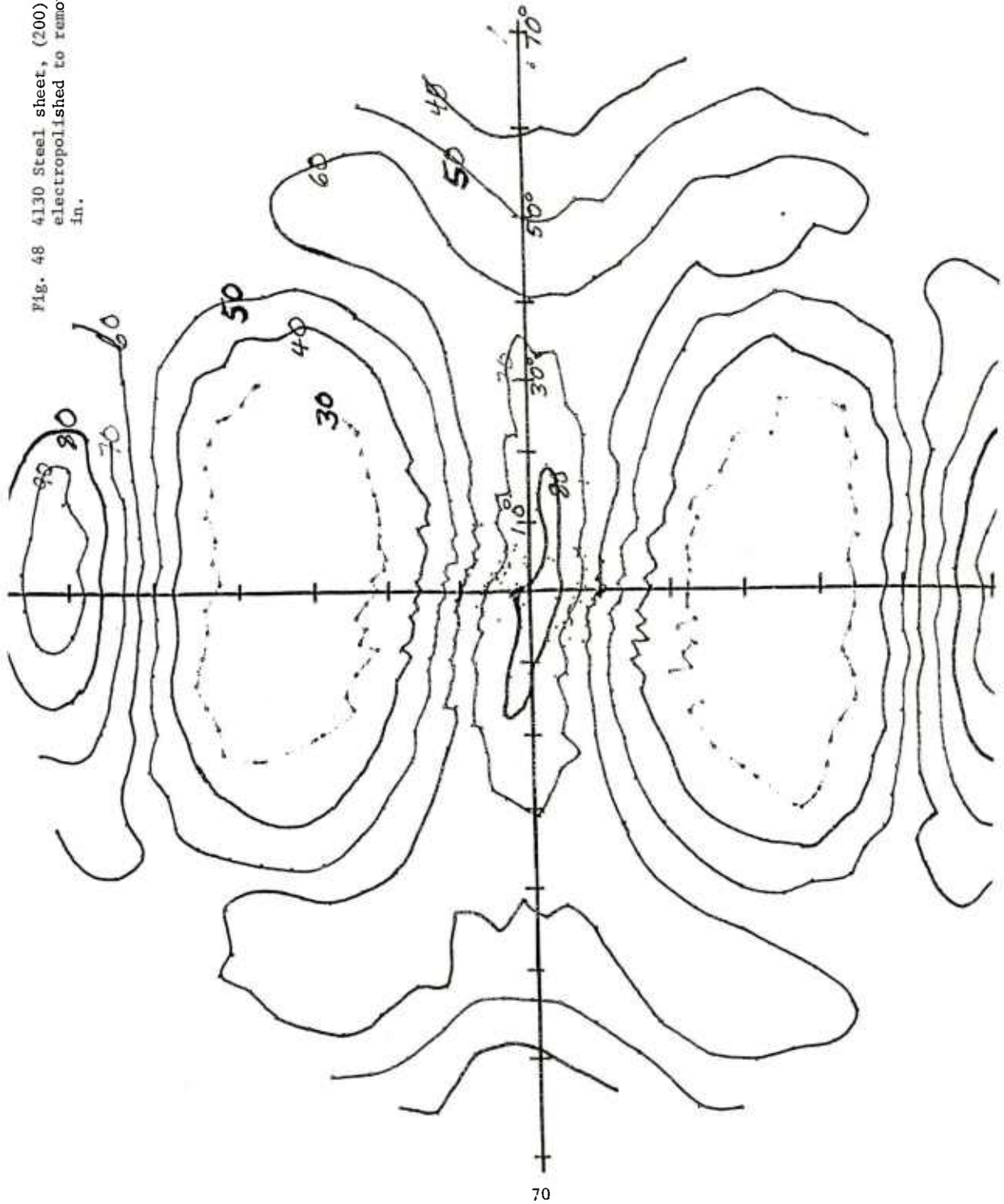

Fig. 49 4130 Steel sheet, (211) pole,  
electropolished to remove .008  
in. texture goniometer set for  
15 mm oscillation.

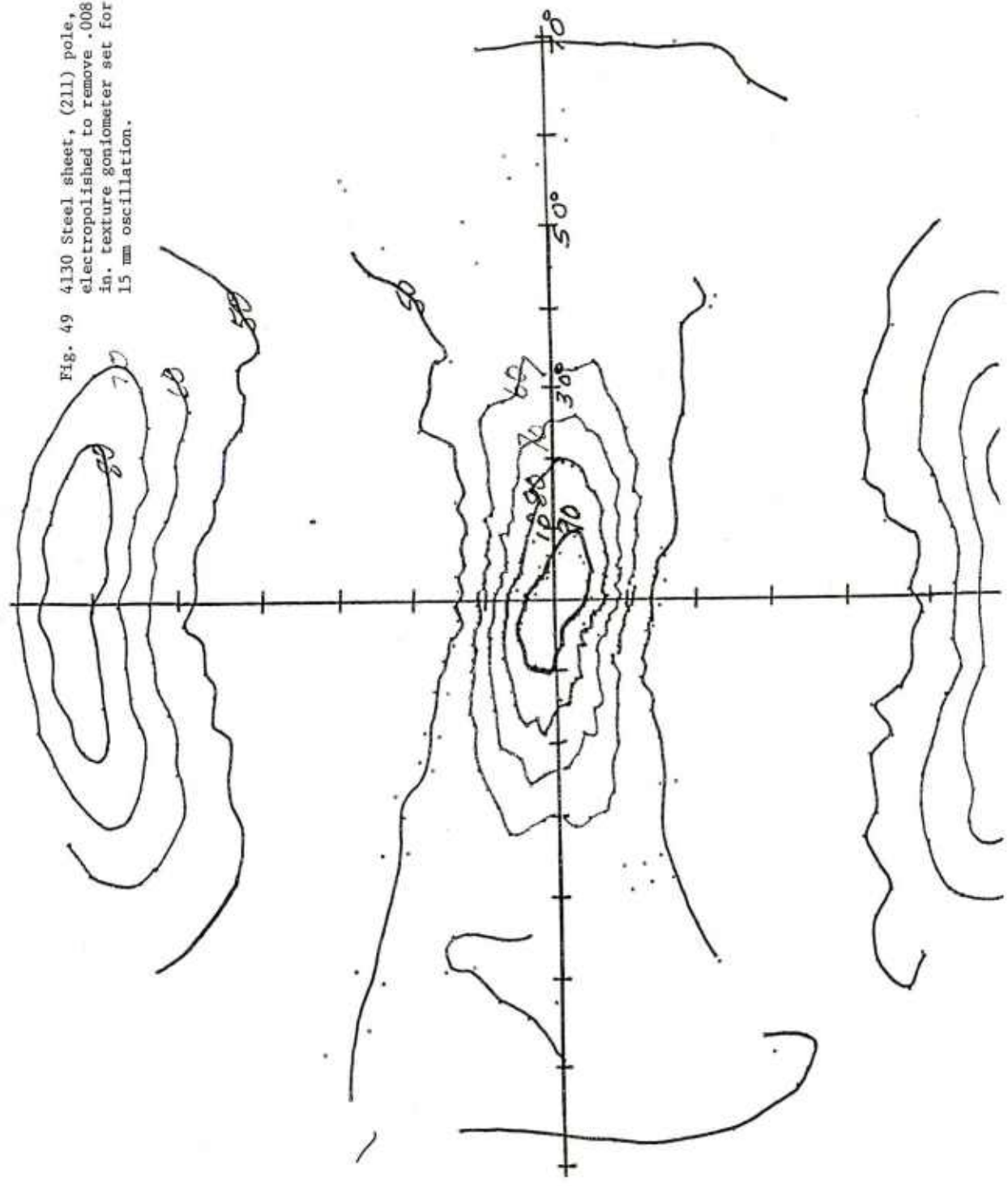
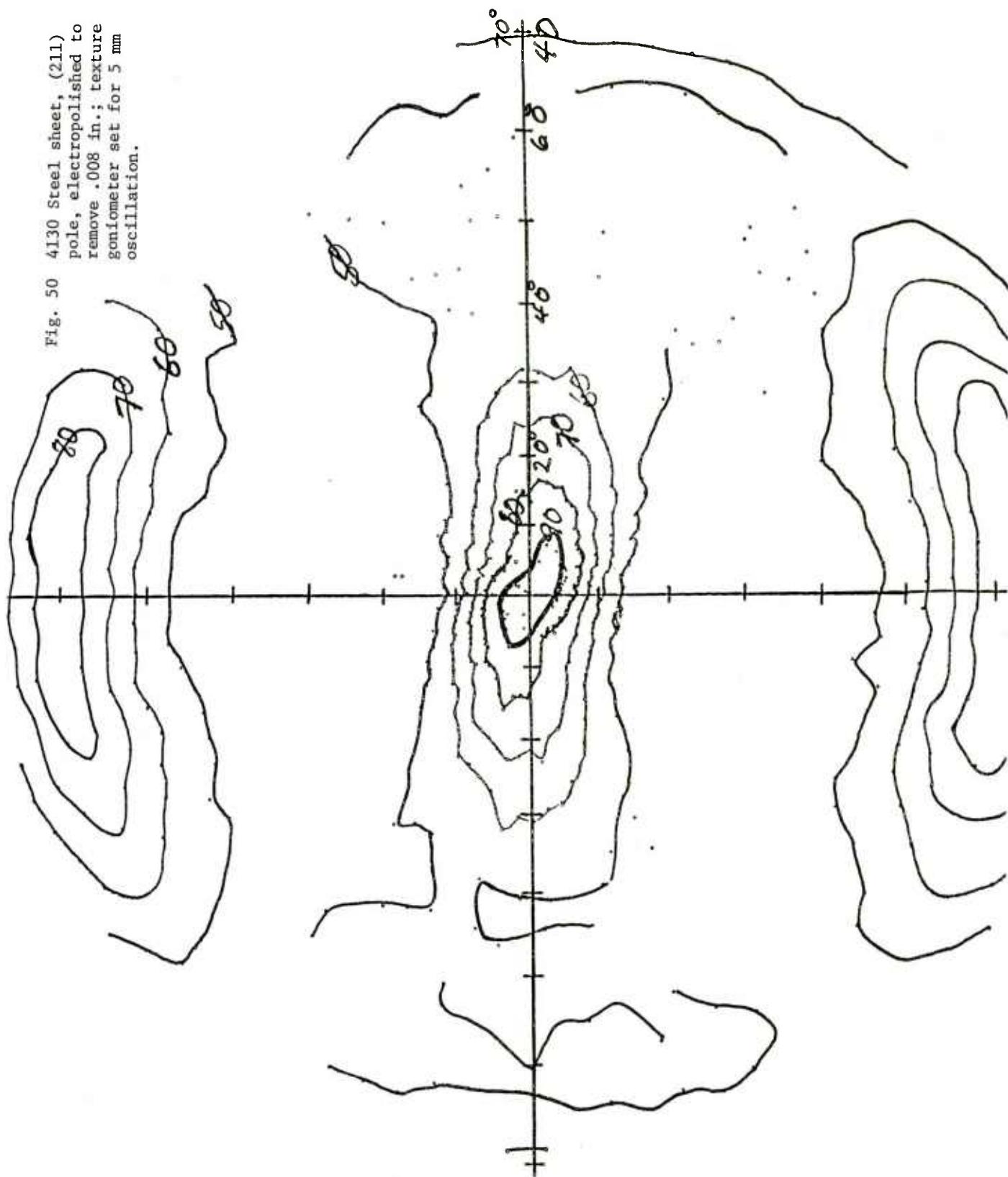

Fig. 50 4130 Steel sheet, (211)  
pole, electropolished to  
remove .008 in.; texture  
goniometer set for 5 mm  
oscillation.



parallelism of the hole bottom and the top surface of the block, and surface finish of both the hole bottom and the top surface of the block. The second area involved a feasibility study of the fabrication of reference blocks from more than one piece of material.

a. Dimensional Measurements

Fifty-four blocks fabricated from the supply of NBS 7075-T651 aluminum alloy, 3 blocks fabricated from fused quartz material, and 6 7075-T6 aluminum alloy blocks that were rejected by a block manufacturer were checked for adherence to the hole diameter specifications of ASTM E 127-75 (required diameter  $\pm 0.0005$  in (0.0013 mm)). A mechanical comparator that magnified the motion of a split-ball probe was used in this effort. A dial gage readout with 0.0001 in (0.0025 mm) increments provided diametral differences from an initial reading of a standard. Both hole diameter and diametral variations (out of roundness) were measured. Hole diameter differences from nominal values were as large as 0.0040 in (0.1016 mm) with "roundness" deviations up to 0.0015 in (0.0381 mm). The mean differences from the nominal values were more representative of the specified tolerance at approximately 0.0007 in (0.0178 mm) with average "roundness" deviations of 0.0004 in (0.0102 mm). An attempt was made to correlate hole diameter deviations and ultrasonic response deviations (Section 3.3) but no obvious relationship was evident.

Pat McEleney of AMMRC has presented unpublished data to an ASTM Committee that indicates that the ultrasonic response from a test piece varies not only with the rms surface finish of the top surface of the test piece but also with the different techniques used to produce the same rms surface finish. This is an interesting result in view of the fact that

3 distinct finishing patterns were noticed on commercially supplied blocks and the blocks produced from NBS-supplied material. Three of the purchased blocks (2 from one manufacturer) were sent to the Optics and Micrometrology Section at NBS for surface finish characterization by the arithmetic average (AA) value and autocorrelation techniques. The procedures and the equipment for this work are described in [14].

Two distinct machining patterns were visually evident on the 3 blocks whose entry surfaces were characterized. The entry surface of two of the blocks were milled in a linear pattern while the third was apparently turned on a lathe. A linear surface profile, 0.11 in (2.8 mm) in length was taken near the center of each specimen. Typical surface profiles, the amplitude density functions (histograms), and the autocorrelation functions are shown for the profiles of the 3 blocks (Figs. 51 to 55). Both across-the-grain and with-the-grain profiles are included for the two milled specimens. An arithmetic average value (similar to rms value) and an average characteristic wavelength were calculated for each profile measurement. These values are listed in Table 9. Ultrasonic reflection data (Table 9) were taken over the top surfaces of these 3 blocks at 5 and 10 MHz. The variation in the amplitude of the energy reflected from the top surfaces of the blocks was 7.7 percent in the worst case between the 2 machining processes - 4.4 percent between the similarly machined blocks. No point-to-point correlations were made between surface finish and ultrasonic reflection data.

Further work correlating the ultrasonic response at several frequencies to the surface properties of test pieces is anticipated. Difficulties have been encountered in the measurement of other dimensional parameters,

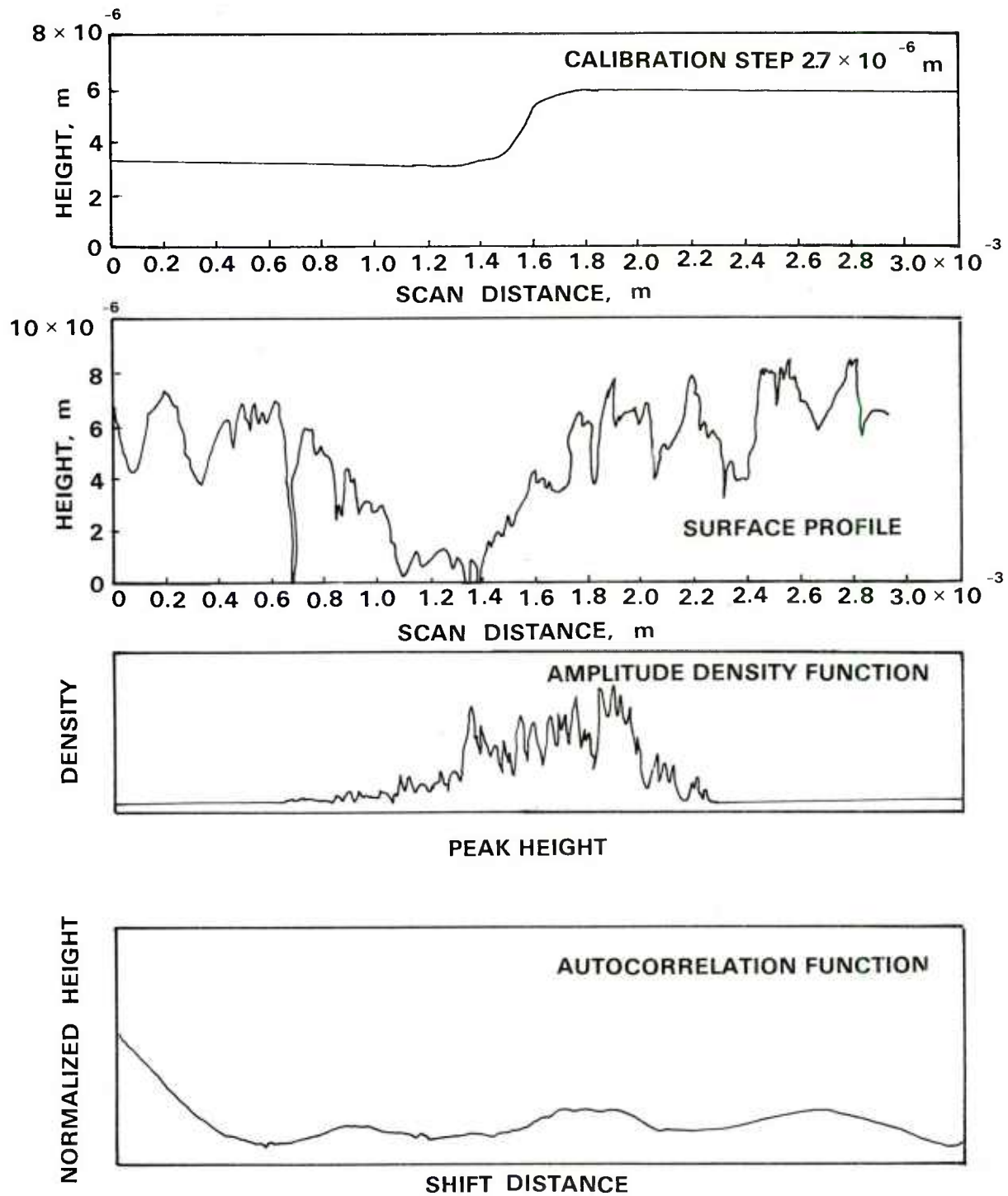

Fig. 51 - SURFACE ROUGHNESS DATA (SCAN 1A) FOR SPECIMEN B-0121 (5-0012 REFERENCE BLOCK). THIS DATA WAS TAKEN NEAR THE CENTER PEAK OF THE TURNED SURFACE.

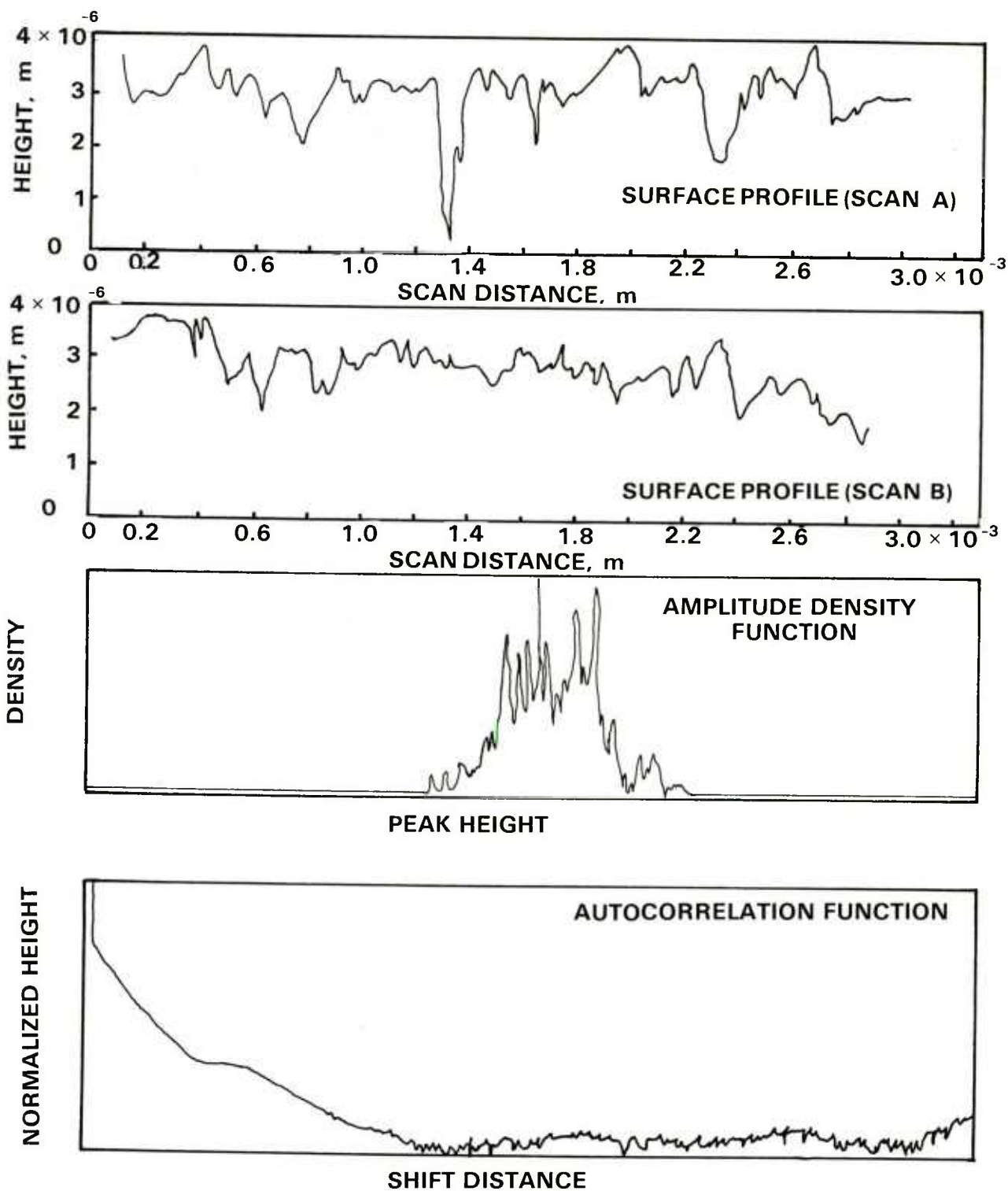

Fig. 52 - "WITH THE GRAIN" SURFACE ROUGHNESS DATA FOR SPECIMEN 123 (8-0006 REFERENCE BLOCK). NOTE THE TWO DEPRESSIONS IN SCAN A.

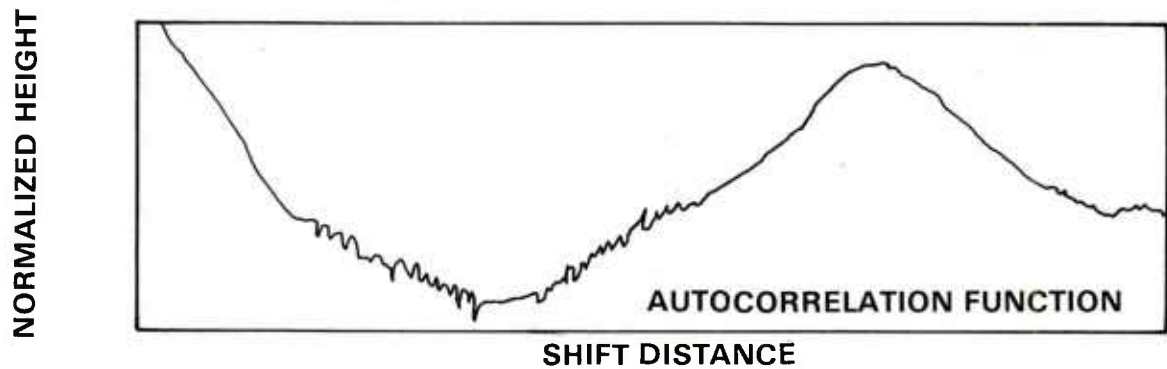
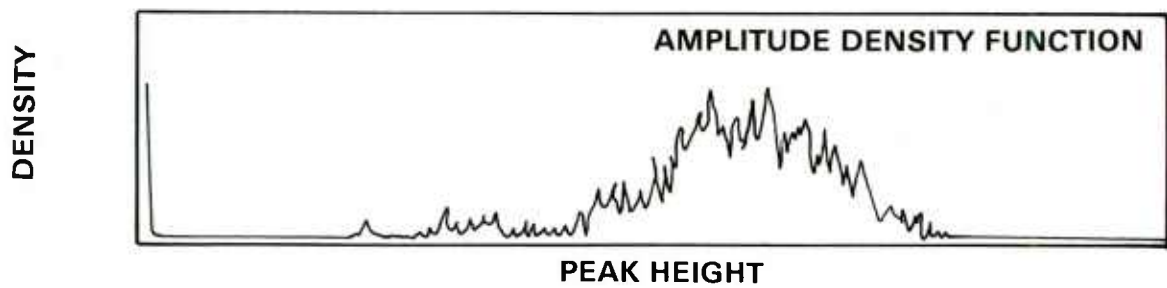
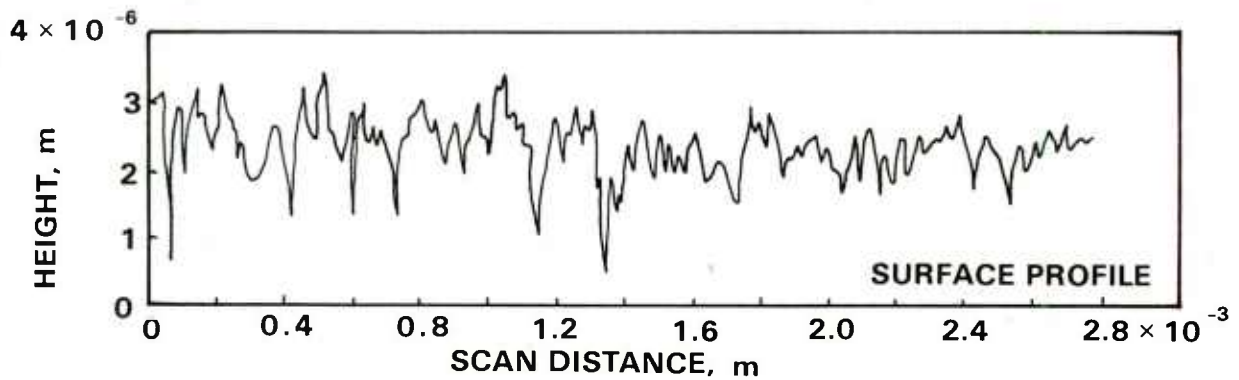
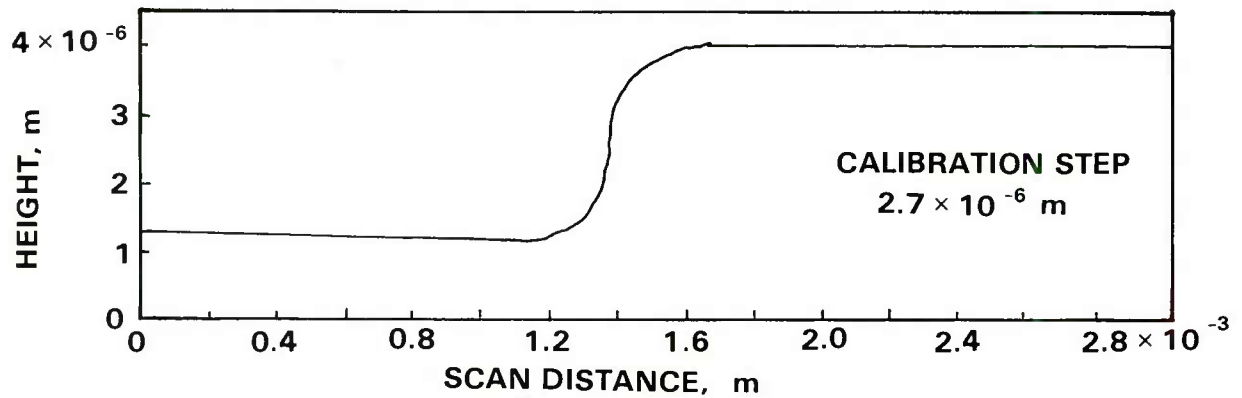

Fig. 53 - "ACROSS THE GRAIN" SURFACE ROUGHNESS DATA FOR SPECIMEN 123 (8-0006 REFERENCE BLOCK)

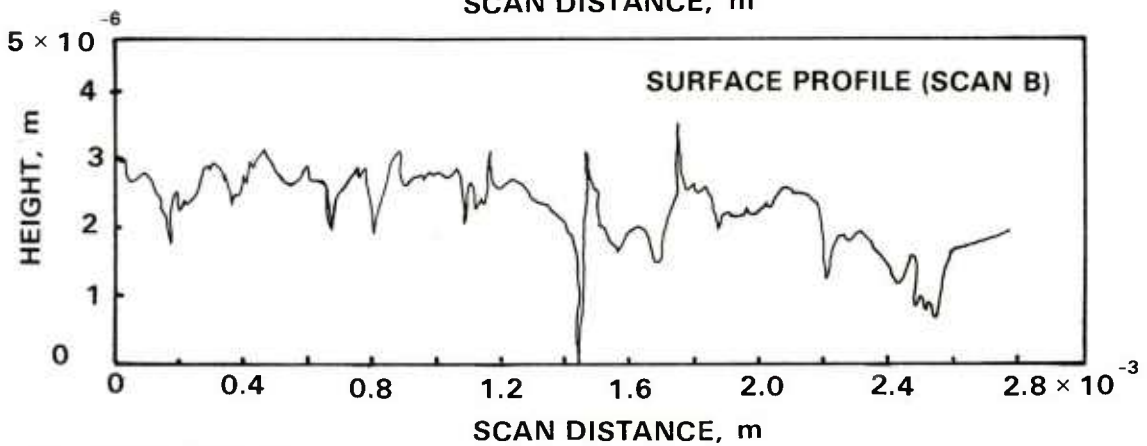
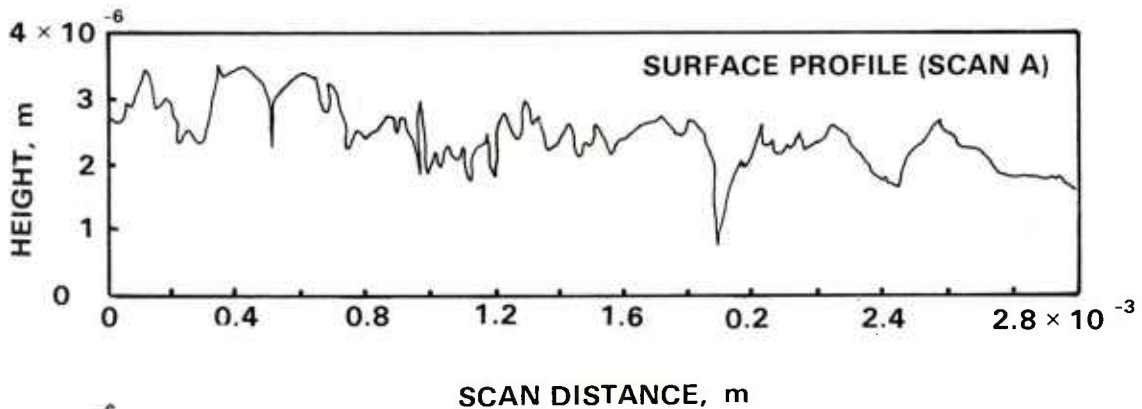
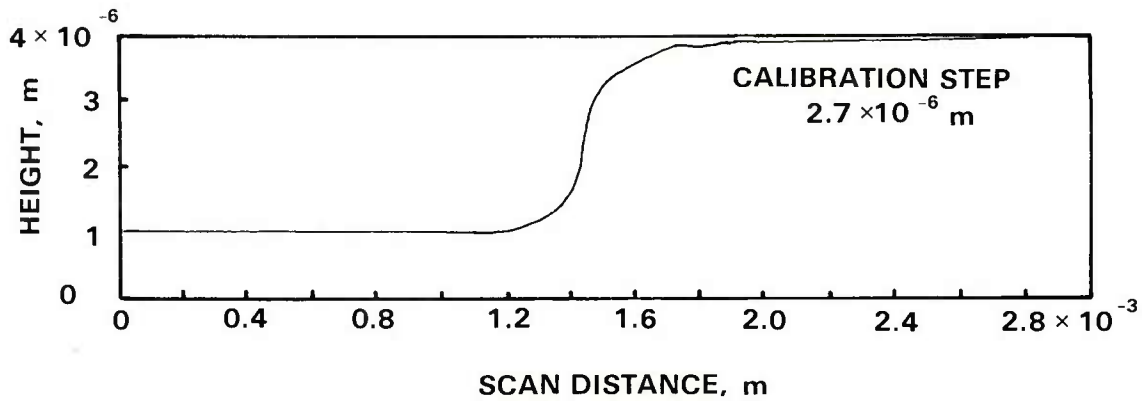

Fig. 54. - "WITH THE GRAIN" SURFACE ROUGHNESS DATA FOR SPECIMEN 123 (8-0012 REFERENCE BLOCK).

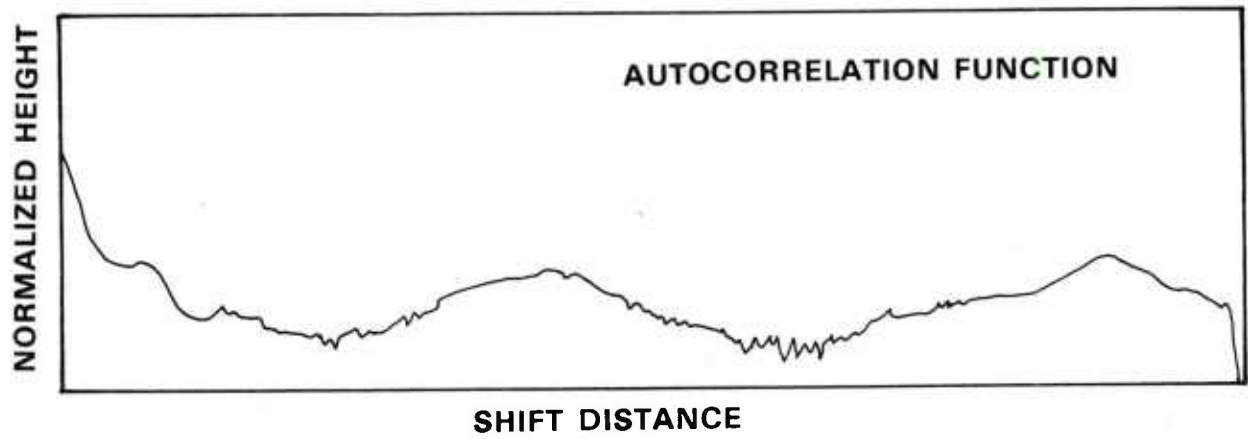
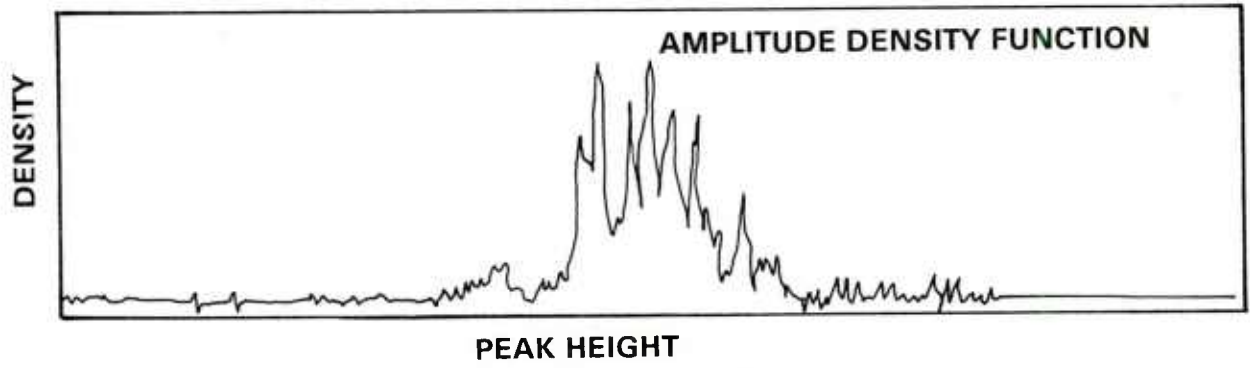

Fig. 54 - CONT'D.

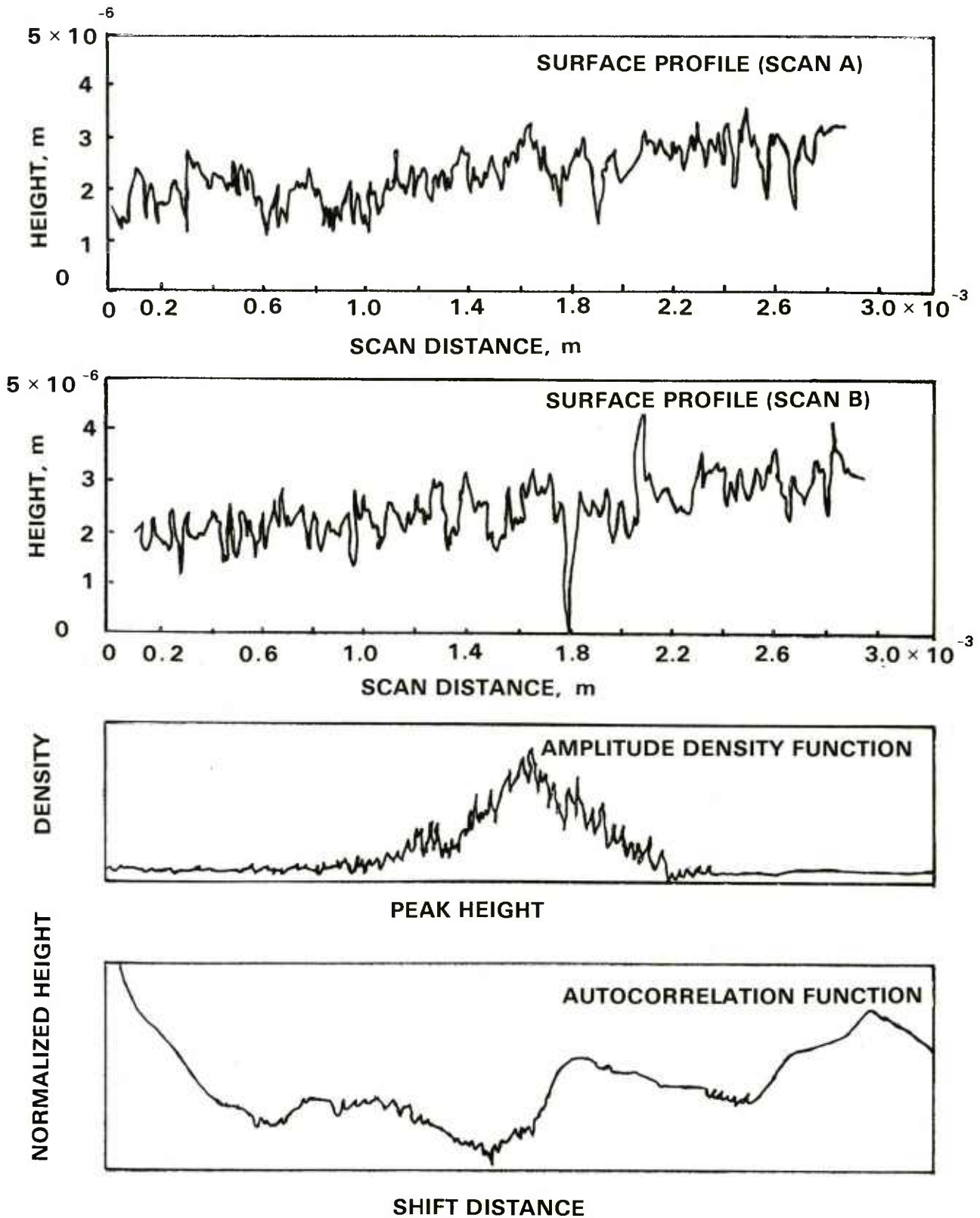

Fig. 55 - "ACROSS THE GRAIN" SURFACE ROUGHNESS DATA FOR SPECIMEN 123 (8 -0012 REFERENCE BLOCK).

TABLE 9. AVERAGE SURFACE PROFILE VALUES.

| Specimen<br>SN | Size   | Scan   | Arithmetic Average<br>Surface Roughness |                      | Characteristic<br>Wavelength |                     | Ultrasoundic<br>Response<br>Limits |       |
|----------------|--------|--------|---|----------------------|------------------------------|---------------------|------------------------------------|-------|
|                |        |        | With<br>Grain                           | Across<br>Grain      | With<br>Grain                | Across<br>Grain     | 5MHz                               | 10MHz |
|                |        |        | m                                       | m                    | m                            | m                   |                                    |       |
| B-0121         | 5-0012 | 1 A(a) | $724 \times 10^{-9}$                    |                      | $167 \times 10^{-6}$         |                     | 84-85                              | 86-90 |
|                |        | 1 B(a) | 716                                     |                      | 100                          |                     |                                    |       |
|                |        | 2 A    | 483                                     |                      |                              |                     |                                    |       |
|                |        | 2 B    | 485                                     |                      |                              |                     |                                    |       |
|                |        | 3 A    | 649                                     |                      | 182                          |                     |                                    |       |
|                |        | 3 B    | 657                                     |                      |                              |                     |                                    |       |
| 123            | 8-0006 | A (b)  | 346                                     | $292 \times 10^{-9}$ | 322                          | $94 \times 10^{-6}$ | 86-87                              | 88    |
|                |        | B      | 199                                     | 294                  |                              |                     |                                    |       |
| 123            | 8-0012 | A      | 212                                     | 248                  | 132                          | 82                  | 86-90.5                            | 87-88 |
|                |        | B      | 220                                     | 288                  |                              |                     |                                    |       |

(a) Measurements were taken near center peak of turned block (Fig. 51)

(b) Measurements were taken over a path containing two holes (Fig. 52)

such as the corner radius of the hole bottom, parallelism of the hole bottom and the top surface of the block (except by ultrasonic methods) and the surface finish of the hole bottom. A hole replication technique similar to that done at Curtiss-Wright by Michaelsohn<sup>†</sup> or as outlined in [2] has been tried at NBS. Such replicates seem to provide a satisfactory media for the measurement of some of the flat-bottom hole's characteristic dimensions of the larger diameter holes.

#### b. Multi-piece Reference Blocks

One new, promising concept in the fabrication of ultrasonic reference standards involves the assembly of several pieces of material to produce one reference standard. The main advantage to this procedure is the chance to obviate the problems associated with dimensions of the reflector (e.g. the corner radius, surface finish, etc. of the flat-bottom hole). Using this concept, an ASTM type reference block might consist of two cylinders, one solid and one with a through hole, "bonded" together to form an ultrasonic reference block.

Kettering at Grumman has fabricated multi-piece titanium standards by sandwiching a thin titanium foil containing well-characterized defect holes between two solid titanium blocks [7]. The 3 pieces are then diffusion bonded. Paton at Rockwell has similarly produced titanium and steel two-piece blocks with spherical and spheroidal cavities and forecasts that this process will soon be feasible for aluminum and stainless steels [11]. Metallographic and ultrasonic examination diffusion bonded reference blocks have confirmed the bond line quality and ultrasonic transparency in some cases.

---

<sup>†</sup>Private communication to ASTM committee E 7.06.02.

The NBS activity in this area has concentrated on wringing together two pieces of material to produce a bond line which is almost ultrasonically invisible. Initial experiments were performed on steel gage blocks, aluminum cylinders, and quartz cylinders. These pieces had very flat surfaces (0.5 fringe or better) and very fine surface finishes (2  $\mu$  in or better). The 2 steel gage blocks were "wrung" together using conventional gage block techniques. Ultrasonic data was taken on the "wrung" steel gage blocks at 5 MHz. The reflected energy received from the interface was less than 10 percent of the back surface reflection. Two quartz discs, one with a 0.125 in diameter through hole, were also "wrung" together. The ultrasonic response from the interface was less than 5 percent of the back surface reflection at 2.25, 5, 10, and 15 MHz. Usually this was within the "noise" of the measurement system; the bond was essentially "transparent". Attempts to wring the aluminum cylinders produced negative results and surface finish damage to the cylinder faces.

The wrung quartz block was placed in a furnace in an attempt to fuse the two pieces into one block. The procedure was not well controlled and the resultant fused block contained areas of disbond at the interface. The sections of this block that were fused produced no detectable ultrasonic interface signal over the range of frequencies from 2.25 to 15.0 MHz. Based on this data, it appears that "wrung" blocks may be feasible for steel or quartz, but probably not for aluminum.

## 6. Effects of the Ultrasonic Measurement Systems

It is evident that the metallurgical and fabrication aspects of ultrasonic reference block production can account for a significant percentage of the variation in the response between nominally identical

standards. This is only part of the problem; several parts of the overall measurement system can affect the response received from the same standard. Consider as a basic ultrasonic measurement system one composed of a mainframe, a pulser/receiver combination, a transducer, and an operator. Variations in response arise by changing the electronic components (pulser, receivers, mainframes, transducers, etc.), the operators, or some of the equipment control settings. Changes to this basic test system were made in order to document the effects of those changes on the measurement response of the ultrasonic system.

The ultrasonic transducer is the one component of the basic ultrasonic measurement system that is most likely to be broken, abused, or misplaced and, therefore, need to be replaced by another "nominally identical" unit. But what exactly do we mean by the term "nominally identical"? Certainly, for a transducer, some basic characteristics should be within appropriate limits. The ASTM E 127-75 document [3] contains a section listing the characteristics that a transducer must possess to be suitable for checking the response from aluminum reference standards. The important parameters in that list include the center frequency, the distance-amplitude curve shape, the location of the  $Y_0^+$  landmark, and the beam profiles at the  $Y_0^+$  and  $Y_1^-$  landmarks.

Five "nominally identical" 5.0 MHz center frequency, 0.375 in (9.52 mm), quartz crystal transducers were evaluated according to the guidelines in [3]. Three of these 5 transducers (designated as Lab Standards, LS-1, LS-2, and LS-5) were produced by one manufacturer, while the other 2 (LS-3 and LS-4) came from a competing firm. The transducer pairs LS-1 LS-2 and LS-3, LS-4 were presumably produced consecutively as they were delivered in pairs with sequential serial numbers. Some measured characteristics

of these 5 transducers are listed in Table 10. Based on the data in Table 10 the 5 transducers are reasonable facsimiles of each other in frequency, beam size, and axial profile shape, but LS 1 and LS 3 are not suitable for checking the response from aluminum reference standards according to ASTM E 127-75. The peak height differences at the  $Y_1^-$  point (LS-1) and the location of the  $Y_0^+$  point (LS-3) are not within the tolerances specified in [3].

The E 127-75 procedure uses the response from a steel ball and a "qualified" transducer to establish the measurement system gain for checking the response from aluminum reference blocks. The relating ball-to-block response was measured for one No. 3, 5, and 8 reference block with a 0.50 in (13 mm) metal travel blocks using all 5 transducers. The results (Table 11) of the ball-to-block comparison differed by 14 to 18 per cent for the 5 transducers. This practical result should also be considered in qualifying "nominally identical" transducers. Combining the information in Tables 10 and 11 only LS-3 and LS-4 are nominally the same.

Other discriminating characteristics need to be specified in order to accurately characterize a transducer. One good technique appears to be the measurement of the relative power output versus excitation frequency curve for a transducer. These curves for the 5 quartz transducers are shown in Figures 56 to 60.\* Again LS-3 and LS-4 are a good match. Because of the consistent similarities in all characteristics measured, LS-3 and LS-4 were considered the best among the five and were chosen for use in the limited calibration service described in Section III-9.

---

\*These measurements were taken in the Auditory Acoustics Section at NBS. Further information about the procedure can be obtained from F. R. Breckenridge or C. E. Tschiegg, Auditory Acoustics Program Team, National Bureau of Standards, Washington, D.C., 20234.

TABLE 10. QUARTZ TRANSDUCER CHARACTERISTICS

|                             | LS-1       | LS-2       | LS-3       | LS-4       | LS-5       |
|-----------------------------|------------|------------|------------|------------|------------|
| $Y_0^+$                     | 3.25(8.3)  | 3.38(8.6)  | 3.62(9.2)  | 3.5(8.9)   | 3.62(9.2)  |
| in (cm)                     |            |            |            |            |            |
| $Y_1^-$                     | 1.6 (4.1)  | 1.6 (4.1)  | 1.6 (4.1)  | 1.6(4.1)   | 1.65(4.2)  |
| in (cm)                     |            |            |            |            |            |
| $Y_1^-$ peak ratio          | 1.24       | 1.09       | 1.12       | 1.10       | 1.13       |
| -6dB beam width at $Y_0^+$  | 0.10(0.25) | 0.11(0.28) | 0.11(0.28) | 0.11(0.28) | 0.11(0.28) |
| in (cm)                     |            |            |            |            |            |
| Center frequency (a)        | 5.03       | 5.00       | 4.86       | 4.85       | 5.09       |
| MHz                         |            |            |            |            |            |
| Center frequency (b)        | 4.94       | 5.00       | 4.90       | 4.85       | 5.03       |
| MHz                         |            |            |            |            |            |
| -6dB bandwidth (a)          | 1.33       | 1.09       | 0.91       | 1.0        | 1.34       |
| MHz                         |            |            |            |            |            |
| No. of cycles > 10 per cent | 7          | 7          | 8          | 8          | 6          |

(a) From spectrum analyzer, broadband pulser, return signal from flat plate.

(b) Frequency at maximum power output.

Block - to - Block

TABLE 11. EFFECTS OF DIFFERENT TRANSDUCERS ON  
RELATIVE BALL-TO-BLOCK RESPONSE.

|              | TRANSDUCERS |      |      |      |      | <u>SPREAD</u><br>AVG., % |
|--------------|-------------|------|------|------|------|--------------------------|
|              | LS-1        | LS-2 | LS-3 | LS-4 | LS-5 |                          |
| 1/8" Ball    | 80          | 80   | 80   | 80   | 80   | 16.90%                   |
| 3-0050 Block | 94          | 82.5 | 98   | 95   | 89   |                          |
| 5/16" Ball   | 80          | 80   | 80   | 80   | 80   | 17.68%                   |
| 5-0050 Block | 79.5        | 75   | 89.5 | 86.5 | 79.5 |                          |
| 11/16" Ball  | 80          | 80   | 80   | 80   | 80   | 14.39%                   |
| 8-0050 Block | 81          | 78   | 90   | 87.5 | 80.5 |                          |

All 5.0/0.375 quartz immersion transducers  
water path = 3.5"

All numbers average of at least 3 readings

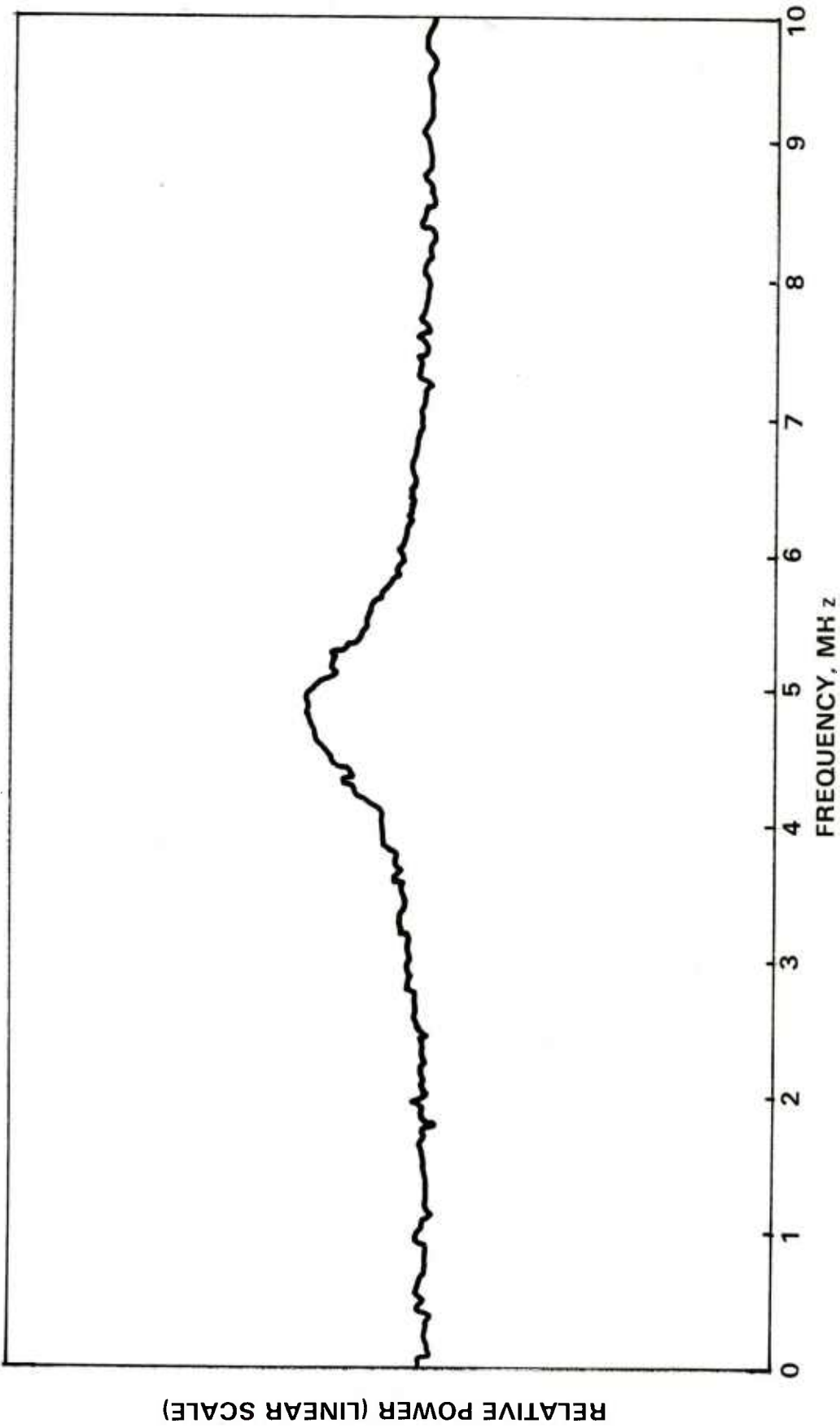

Fig. 56 - RELATIVE POWER OUTPUT VERSUS EXCITATION FREQUENCY FOR TRANSDUCER LS-1.

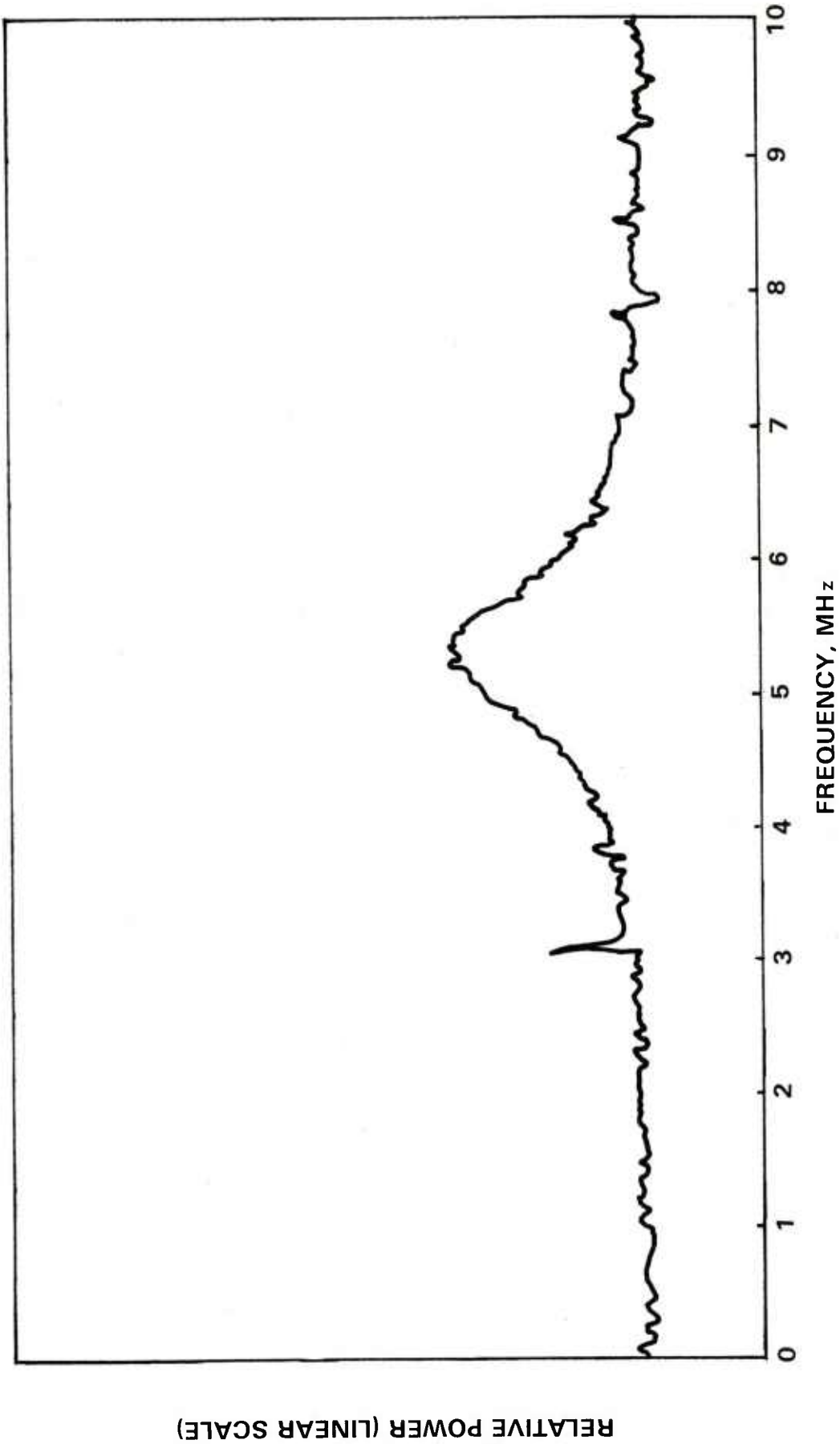
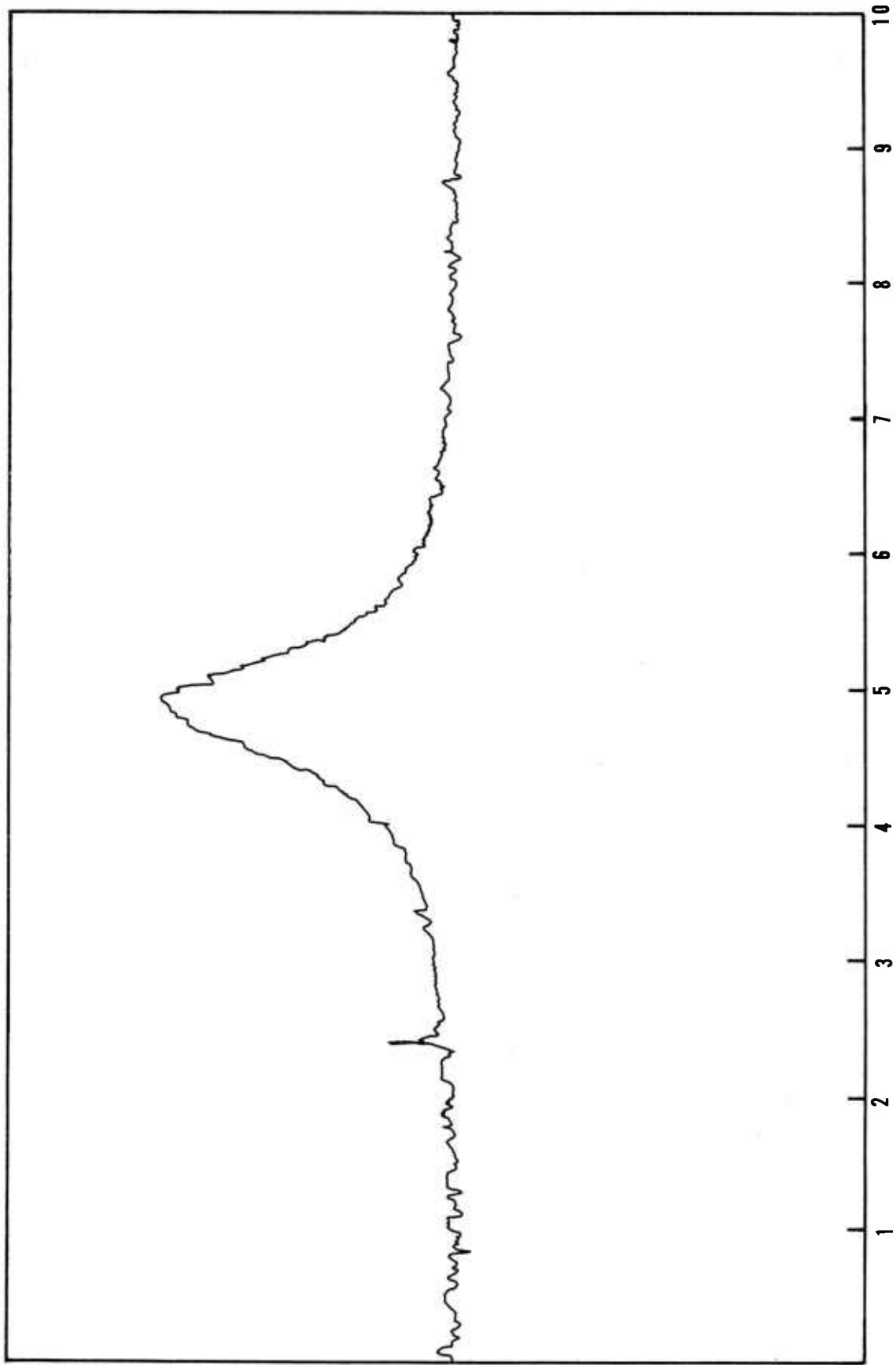

Fig. 57 - RELATIVE POWER OUTPUT VERSUS EXCITATION FREQUENCY FOR TRANSDUCER LS-2.



FREQUENCY, MHz

FIGURE 58 - RELATIVE POWER OUTPUT VERSUS EXCITATION FREQUENCY FOR TRANSDUCER LS-3

RELATIVE POWER (linear scale)

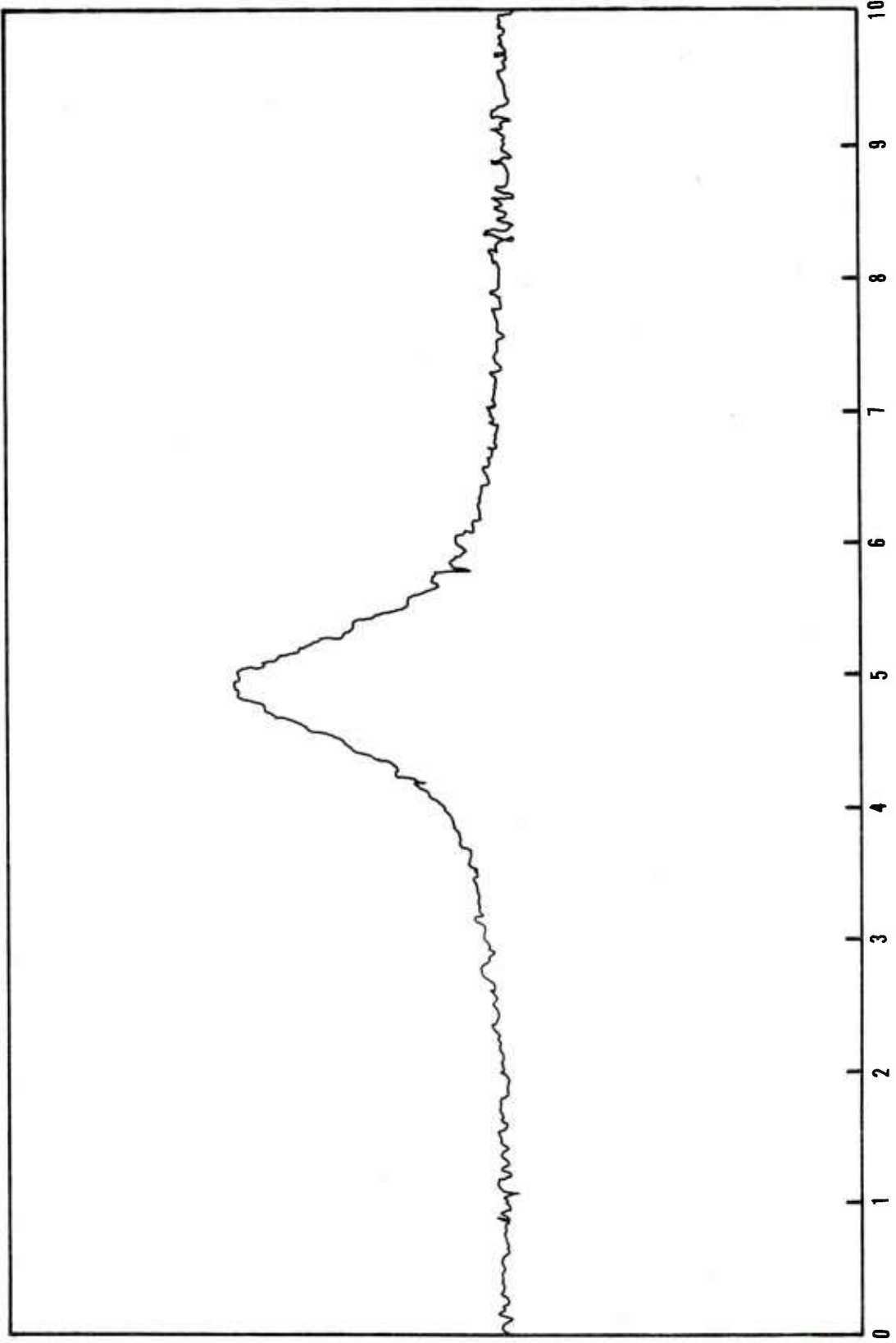

FIGURE 59 - RELATIVE POWER OUTPUT VERSUS EXCITATION FREQUENCY FOR TRANSDUCER LS-4

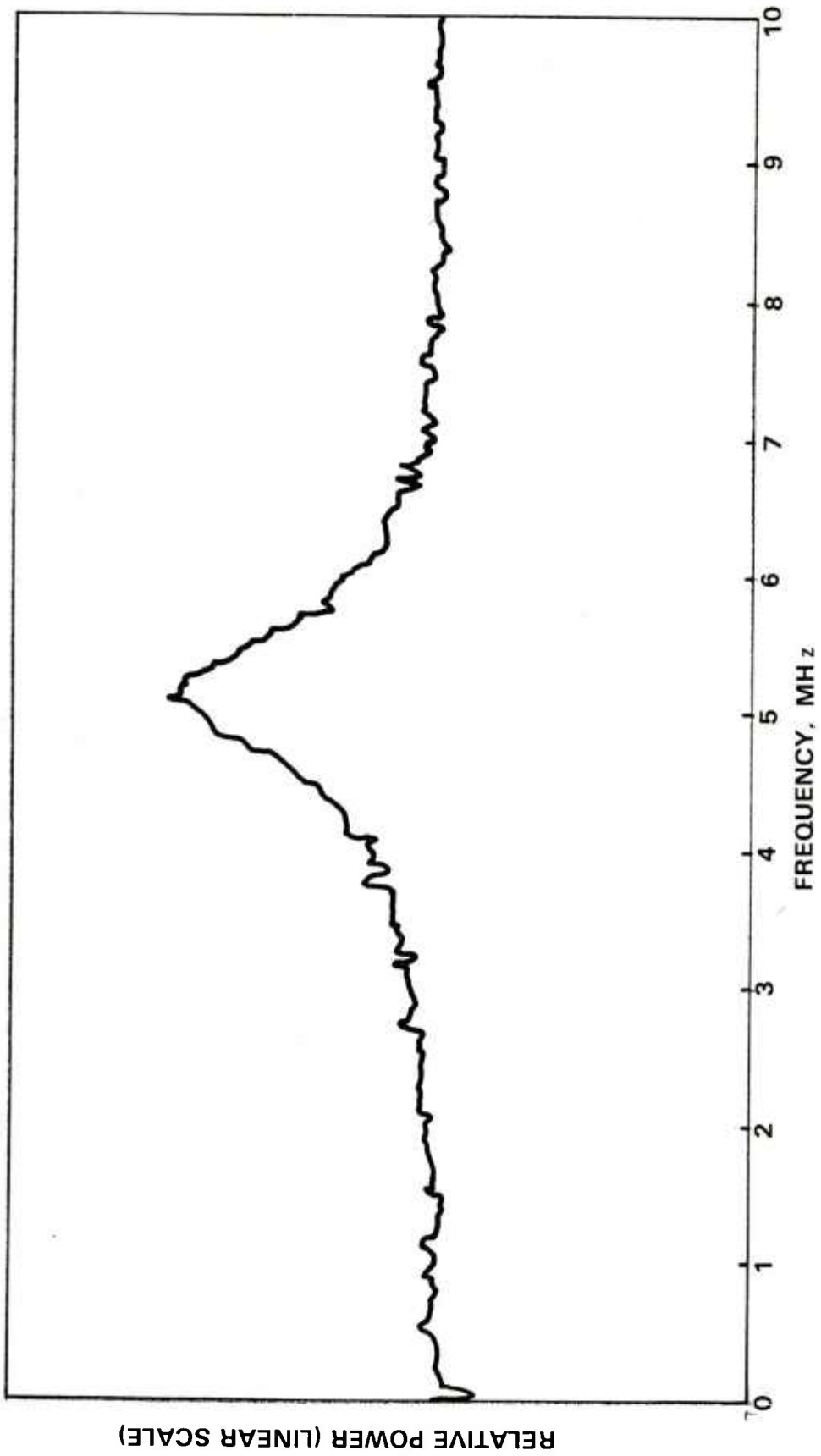

Fig. 60 -RELATIVE POWER OUTPUT VERSUS EXCITATION FREQUENCY FOR TRANSDUCER LS-5.

The practical limitations of using a ball-to-block transfer response are evident from the data in Table 11. Table 12 demonstrates the effect of changing transducers for a block-to-block transfer. The overall effect is a 13 percent variation which represents an improvement over the ball-to-block results. The important fact to note is the less than 3 percent variation in response between the LS-3, LS-4 pair.

The effects of changing some of the other system parameters were also investigated. For example the variability in response that can exist between different laboratories and different operators had been previously documented [8]. Data showing the variability in response that can occur by changing the pulser/receiver unit is presented in Table 13. These results were obtained using a ball-to-block transfer mechanism.

Other variations can arise from more subtle equipment changes. Cable length and type can affect the center frequency and signal amplitude of the signal received by the ultrasonic system. This data is presented in Table 14 for a 10 MHz, 0.25 in (6.4 mm) ceramic transducer. The effect of changes to the gain reference level ("cal" pot) of the receiver and the pulse length of the pulse were demonstrated for both a ball-to-block and block-to-block relative response. These data are presented in Tables 15 and 16 respectively. In each case the relative block-to-block comparison is affected less by these adjustments.

Figure 61 demonstrates graphically the effect of evaluating the response from one set of No. 5 reference blocks using the same electronic system. The 2 transducers (LS-3 and LS-4) selected for use in the calibration service were used by 3 different NBS operators on 9 relative block-to-block comparison runs. These 9 data sets showed very little variation (generally

TABLE 12. THE EFFECTS OF DIFFERENT TRANSDUCERS ON RELATIVE BLOCK-TO-BLOCK RESPONSE :

| TRANSDUCER | LS-1 | LS-2 | LS-3 | LS-4 | LS-5 | SPREAD<br>AVG. % |
|------------|------|------|------|------|------|------------------|
| 3-0050     | 80   | 80   | 80   | 80   | 80   |                  |
| 5-0125     | 91.5 | 94   | 92   | 97   | 95.5 | 5.85%            |
| 8-0325     | 70   | 75.5 | 75   | 79.5 | 77.5 | 12.58%           |

All numbers average of 4 readings

All 5/0.375 quartz immersion transducers  
water path - 3.5"

TABLE 13. THE EFFECTS OF DIFFERENT PULSER/ RECEIVER UNITS:  
ON RELATIVE BALL-TO- BLOCK RESPONSE.

| Block      | Amp1 | Amp1 | Amp1 | Amp1 |
|------------|------|------|------|------|
| 3/16" ball | 100  | 100  | 100  | 100  |
| 8-0300     | 90   | 75   | 84   | 70   |
| 7-0300     | 70   | 55   | 63   | 52   |
| 6-0300     | 53   | 41   | 50   | 38   |
| 5-0300     | 36   | 27   | 33.5 | 25   |
| 4-0300     | 25   | 18   | 23   | 17   |
| 3-0300     | 13   | 10   | 11   | 9    |
| 2-0300     | 5    | 3    | 4.5  | 3    |
| 1-0300     | 0.5  | 0    | 1    | 0    |
| P/R        | 5    | 10   | 5    | 10   |
| Transducer | LS-1 | LS-1 | LS-2 | LS-2 |

TABLE 14. EFFECTS OF DIFFERENT CABLE LENGTHS AND TYPES ON FREQUENCY SPECTRA

| TRANSDUCER                 | W.P. | CABLE TYPE | CABLE LENGTH | CENTER FREQUENCY | SIGNAL AMPL           |
|----------------------------|------|------------|--------------|------------------|-----------------------|
| SN<br>(10 MHz,<br>0.25 in) | in   |            | ft           | MHz              | MV                    |
| 6249                       | 2.5  | RG58c/u    | 2            | 10.6             | 6.0 x 10 <sup>2</sup> |
| 6249                       | 2.5  | RG58c/u    | 3            | 10.1             | 5.0                   |
| 6249                       | 2.5  | RG58c/u    | 4            | 9.6              | 4.3                   |
| 6249                       | 2.5  | RG58c/u    | 5            | 9.3              | 3.7                   |
| 6249                       | 2.5  | RG58c/u    | 6            | 9.0              | 3.3                   |
| 6249                       | 2.5  | RG58c/u    | 7            | 8.75             | 2.7                   |
| 6249                       | 2.5  | RG58c/u    | 8            | 8.5              | 2.4                   |
| 6249                       | 2.5  | RG58c/u    | 9            | 8.32             | 2.4                   |
| 6249                       | 2.5  | RG58c/u    | 10           | 8.1              | 2.4                   |
| 6249                       | 2.5  | RG58c/u    | 11           | 8.0              | 2.3                   |
| 6249                       | 2.5  | RG62/u     | 4            | 9.1              | 6.0                   |
| 6249                       | 2.5  | RG62/u     | 6            | 8.5              | 4.0                   |
| 6249                       | 2.5  | RG62/u     | 10           | 7.7              | 2.2                   |
| 6249                       | 2.5  | RG62/u     | 12           | 7.5              | 2.0                   |

TABLE 15. THE EFFECTS OF VARYING THE "CAL" POT ADJUSTMENT ON RELATIVE BALL-TO-BLOCK RESPONSE.

| STD Ball in | Ball - to - Block |            | Gain dB | Block - to - Block |              | Test Block | Block Response | Gain dB |
|-------------|-------------------|------------|---------|--------------------|--------------|------------|----------------|---------|
|             | STD Response      | Test Block |         | STD Block          | STD Response |            |                |         |
| 5/16        | 80                | 5-0050     | 15      | 5-0100             | 80           | 8-0275     | 60             | 23      |
| 5/16        | 80                | 5-0050     | 11      | 5-0100             | 80           | 8-0275     | 61             | 20      |
| 5/16        | 80                | 5-0050     | 6       | 5-0100             | 80           | 8-0275     | 60.5           | 10      |
| 5/16        | 80                | 5-0050     | 2       | 5-0100             | 80           | 8-0275     | 60.5           | 0       |

Table 16. The Effects of Varying the "Pulse Length" Adjustment on Relative Ball-to-Block and Block-to-Block Response.

| STD Ball in | Ball - to - Block |            | Block Response | Pulse Length | STD Block | Test Block | Block Response | Pulse Length |
|-------------|-------------------|------------|----------------|--------------|-----------|------------|----------------|--------------|
|             | STD Response      | Test Block |                |              |           |            |                |              |
| 5/16        | 60                | 5-0050     | 66             | Min          | 5-0050    | 5-0175     | 25             | min          |
| 5/16        | 60                | 5-0050     | 66.5           | ~1/2         | 5-0050    | 5-0175     | 25             | ~1/2         |
| 5/16        | 60                | 5-0050     | 61             | Max          | 5-0050    | 5-0175     | 25             | max          |
| Trans       |                   |            | LS-1           |              |           |            | LS-2           |              |
|             |                   |            |                |              |           |            | LS-3           |              |

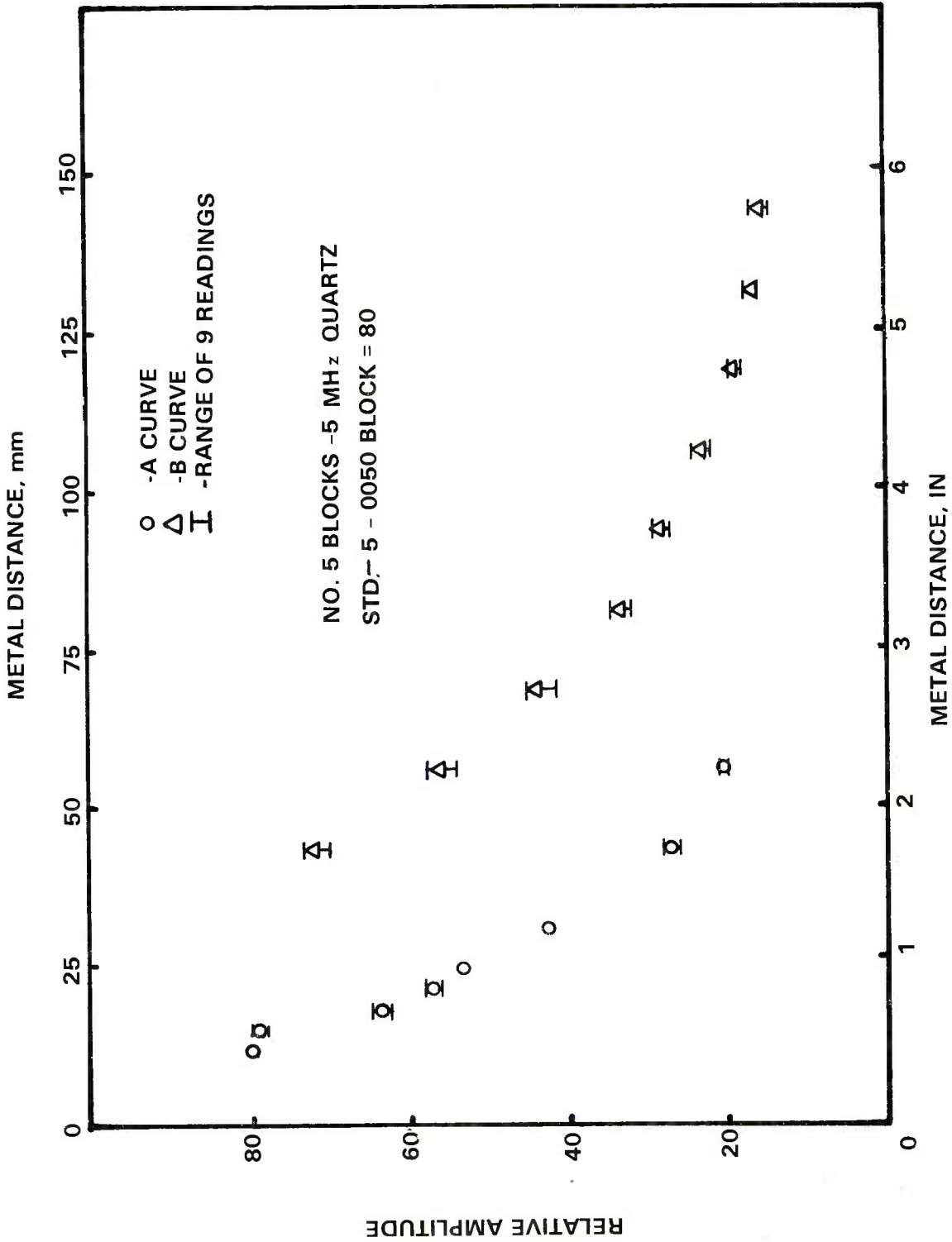

Fig. 61 DATA FROM 1 SET OF NO. 5 REFERENCE STANDARDS USING THE NBS SYSTEM.

less than 4 percent) in ultrasonic response for the block-to-block comparison. The response from this set on the NBS system with LS-3 or LS-4 is now "well characterized". At least 9 data runs were also made on the No. 3 and No. 8 reference block sets owned by NBS using the same measurement system. The results were similar to the data displayed in Figure 61. The response from these sets on the NBS system are also "well-characterized". Figure 62 presents similar data from several different No. 5 reference block sets including the data shown in Figure 61. The variation in response can still be as great as 40 percent, but now the response from these other sets can be referenced to the response from this well characterized data taken previously. A slight extension of this idea leads naturally to a "calibration" procedure.

All of the preceding results were considered and used in the establishment of the procedures for the limited calibrated service Section III-9. Not only was a relative block-to-block comparison used, but procedures were established that would limit the control adjustment that affected either a ball-to-block or block-to-block comparison.

#### 7. Single Material Standard

The concept of using a single-material for the production of ultrasonic standards was well received by the participants at the NBS - NDE Public Review and Workshop in December, 1974. An amorphous material with low attenuation would be a good candidate material. In addition, a material that can be suitably inspected for anomalous characteristics by other than ultrasonic methods (e.g. optical inspection) is desirable. Fused quartz or crown glass are two such materials.

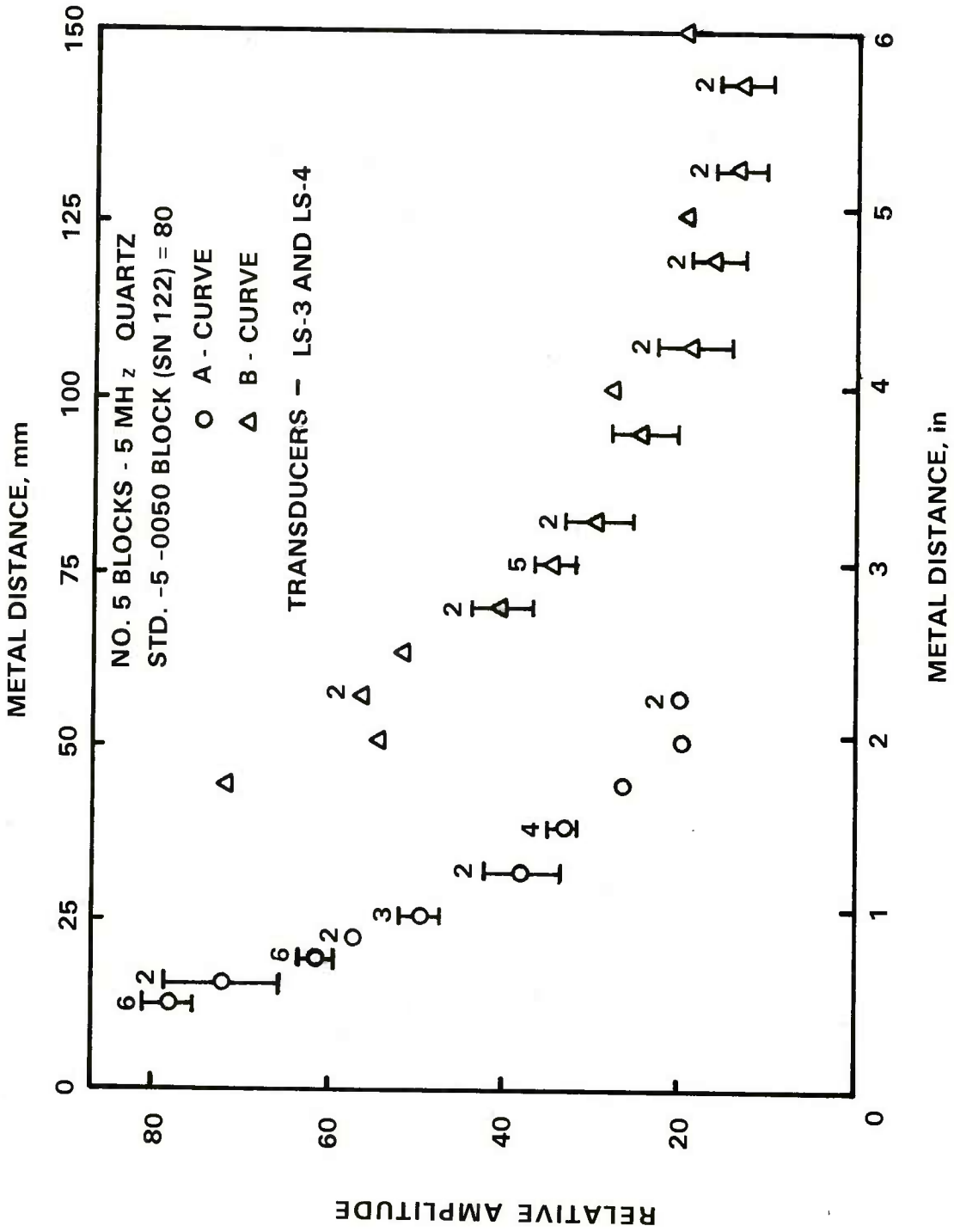

Fig, 62 - DATA FROM SEVERAL SETS OF NO. 5 REFERENCE BLOCKS USING THE NBS SYSTEM

Three reference blocks were machined from two 2 in (51 mm) diameter ingots of fused quartz. The block ends were ground flat and parallel and checked both optically and ultrasonically. Some preliminary photo-elastic data displayed a similar internal stress pattern in all 3 cylinders. Despite these undesirable stress patterns, the reflected amplitude from the back surface of the 3 cylinders varied by less than 5 percent for the frequencies from 2.25 to 15 MHz. Stress-free quartz ingots are also commercially available at a slight increase in material cost.

Flat-bottomed holes were machined into the 3 cylinders to produce No. 3, No. 5, and No. 8 reference blocks with a 3 inch (76 mm) "metal" travel. Hole diameter measurements were within ASTM E 127 tolerances on the No. 5 and No. 8 blocks but 0.0015 in (.0381 mm) oversized on the No. 3 block. "Out-of-roundness" was less than  $\pm 0.001$  in (0.0025 mm) for all three blocks.

The area-amplitude response relationship between the 3 quartz blocks was determined using the theoretical response differences, expressed in decibels as given by:

$$\text{dB difference} = 20 \log \frac{V_1}{V_2}$$

where  $V_1$  and  $V_2$  are the signal amplitudes (voltages) received from the reflectors. The theoretical difference between a No. 8 and a No. 5 hole is 8.16 dB, and the measured value was 8.5 dB. The theoretical difference between a No. 5 and a No. 3 hole is - 8.87 dB, but the measured value was only - 5.1 dB.

There are several disadvantages in producing single-piece quartz blocks. Material and machining costs are high. Each of the three

blocks costs in excess of 260 dollars to produce, reflecting mostly the difficulty of machining quartz without cracking or crazing the material. Despite the care taken in producing the blocks, corner radii and small cracks were evident at each hole tip.

Despite these difficulties, the concept of a quartz single material standard should not be completely discounted. The results on the wrung two-piece quartz blocks (see Section III - 5.) were particularly encouraging. While it is not presumed that such standards would replace the field-use reference blocks, two-piece quartz blocks may be of value as master or primary transfer standards used for equipment standardization and inter-laboratory measurement system comparisons.

#### 8. ASTM Participation

The NBS investigators have continued their active association with the ASTM Committee E 7 on Nondestructive Testing, Sub Committee E 7.06 on Ultrasonics, and particularly E 7.06.02, the working group on Aluminum Reference Blocks. Close contact has been maintained with several members of E 7.06.02 regarding the revision of the E 127 document that took place in 1975. Experiments were performed at NBS to verify the validity of comparing the response from different size (hole diameter) reference blocks on a single (universal) distance-amplitude curve. The data from three sets of blocks, one each set of No. 3, 5, and 8, when plotted on a universal distance-amplitude curve, are shown in Figure 30 of [8]. The scatter between these data appears to be no worse than the scatter between data from different sets of blocks of the same size (Figures 3 to 22). Data taken at NBS, as well as several other labs, were used to determine the appropriate equivalent ball sizes for sensitivity setting when checking

reference blocks. NBS is currently participating in ASTM sponsored studies of material attenuation and curved entry surface reference blocks, and is working on the problem of ultrasonic instrument linearity. Continued participation in activities of mutual interest to ASTM and NBS is planned.

## 9. Calibration Service

Several problem areas have been identified in measuring the response from ASTM-type ultrasonic reference standards. These problem areas arise in the standard itself and the ultrasonic measurement system. While work continues to eliminate these problems, NBS has undertaken the task of establishing a calibration service for ASTM E 127-type reference blocks.

### a. The Measurement Process

The primary goal is the establishment of a proper measurement process for measuring the response of ASTM E 127-type ultrasonic reference blocks. Using the measurement system established at NBS, the difference between the amplitude of response of users' blocks and a reference artifact maintained by NBS is quantified.

In order to formulate a "proper" measurement process, it is necessary to operationally define the measurement unit. Since the quantity of interest, the ultrasonic response of reference blocks, is not derived from any SI base units, there is, in principle, a great deal of arbitrariness in its definition. To emphasize this arbitrariness, the reference artifact maintained by NBS will be considered our interim reference standard, subject to change as the state-of-the art advances. It is anticipated that initially this service will be of most value as a means for comparing the values of different users' blocks. However, as the NBS defined unit becomes accepted (e.g., in contractual agreements), the process can be interpreted in terms

of an "absolute" measurement.

b. Calibration Service Limitations

The calibration service offered by NBS will, initially, be narrow in scope. The set of measurands to be included is restricted to 7075 aluminum alloy, E 127 type reference blocks with metal travel distances ranging from 0.50 in (13 mm) to 6.5 in (165 mm) and flat-bottomed hole diameters from 1 to 8 64ths. The procedures will closely parallel that prescribed in [3] with the major exception of eliminating the ball-to-block response transfer mechanism. A block-to-block calibration transfer will be used. The measurement system variables will be closely controlled and a master standard will be maintained by NBS against which all comparisons will be made. Check standards are also maintained to insure the performance of the NBS measurement system. As improvements to the measurement process are realized, they will be implemented.

The measurement approach is to quantify the difference in relative response between the blocks being calibrated and the master standard. At present these measurements are primarily comparative. This is a limitation imposed by the lack of a precise mathematical model that describes in a physically meaningful way the complex interaction that is taking place. The development of such a model would be the necessary step in the development of an "absolute" measurement process.

A detailed description of the development and implementation of the NBS calibration service can be found in [5].

There are several logical improvements to this outlined measurement system. The measurement process should eventually be extended to include steel and titanium blocks and possibly the interpretive model should be

improved so that the set of measurands can include blocks of any material and so that some of the process restrictions can be removed (e.g. use different frequencies). The system can be further improved by "replicating" the "master" reference and making these available for use with field measurement systems on field reference blocks.

Approximately ten sets of blocks are being produced with a minimum of variability. The remaining variability will be carefully quantified. A set of blocks will be transmitted to a requesting user. On return the set will be recalibrated. This loaner service is scheduled to begin in early 1977.

To keep the measurement system under control, this loaner service should be generalized to a Measurement Assurance Program (MAP), emphasizing feedback to NBS from the user community to insure that good measurements are being made in the field.

#### SECTION IV CONCLUSIONS

The NBS program described herein is devoted to achieving near-term improvements in the reliability of ultrasonic measurements by improving the ASTM-type reference standards system. This report describes work performed in the first two years of a continuing effort. Based on this work the following conclusions are drawn:

1) If the block sets evaluated by NBS to date are typical of the reference block sets available to the NDE community, than a normal variation in ultrasonic response of 20 percent can be expected between nominally identical blocks. However, variations in block response of about 40 percent are not uncommon, and variations as high as 700 percent have been recorded. These variations were measured on the same system but with different operators.

2) The variability between data taken by three operators using the same blocks and the same equipment was measured to be less than about 5 percent. The deviations between readings from two operators using the same blocks and the same search unit but different systems was less than 10 percent.

3) Efforts to manufacture reference blocks from 2 pieces of material have shown this process to be feasible. The particular NBS effort on wrung two-piece blocks has met with mixed success with wrung two-piece quartz, steel, and aluminum blocks. Of these a two-piece quartz standard appears to be the most promising.

4) One-piece quartz blocks were fabricated by NBS from fused quartz ingots. The machining of this material is difficult and the resultant problems associated with the machining processes are evident in the ultrasonic response from these block. A two-piece quartz standard appears to be a more promising candidate for a "single-material" master standard.

5) One-piece aluminum blocks have been fabricated at NBS from a uniform lot of 7075-T651 extruded rod. The spread among nominally identical blocks was less than 10 percent for three different sets.

Five sets of 6 blocks each were fabricated from the same lot of 7075-T651 extruded rod by 2 NBS machinists and the machinists from 3

leading block manufacturers. The variability in the ultrasonic responses of nominally identical blocks was about half of the variability among field blocks. This points to metallurgy as an important variable contributing to field block variability.

6) Metallurgically, an extruded rod will usually contain a uniform texture across the cross section. The final texture (for the case of face centered cubic material) tends from strong (100) texture with rotational symmetry.

The same uniformity of texture is usually not found in rolled or swaged rod. While texture at the rod center may approach that of extruded material, the outer layers will invariably contain orientations not found in the center. The rejected aluminum block studied here also showed a strong (100) texture but lacked the rotational symmetry found in the NBS block (extruded rod). It contained a duplex four-fold symmetry which gave the cross section a nonuniformed texture. To the extent that ultrasonic attenuation is affected by crystal orientation, this texture could contribute to variations in such measurements across the block.

The microstructure and residual stresses appeared to be comparable between the two blocks studied. The differences observed in ultrasonic measurements did not appear to arise from these causes. However, the residual stresses on the surfaces can vary between blocks of the same rod depending on machining practices and polishing techniques. If extruded rod is used for ultrasonic test blocks, care should be exercised in the selection of material as the metallurgical structure can vary along the length of the extrusion.

Only a single rejected steel block was examined metallurgically. Texture studies indicated it had a nearly random texture. No (110) preferred texture was observed. All tests including ultrasonic examination, indicated that this specimen was uniform across the cross section. In electropolished sections, the residual stresses were low, approaching the experimental uncertainty. The specimen was in the annealed condition. No reasons for the rejection of this block were found from metallurgical examination. Studies on rolled steel plate, in contrast, showed a strong orientation texture associated with the fabrication method.

7) A study of the effects of various equipment characteristics has shown that several standard adjustments, notably pulse length and attenuation "cal" adjustment, significantly affect relative ball-to-block response and slightly affect relative block-to-block response. For the NBS calibration service, a block has been selected as the primary reference rather than the ASTM practice of using steel balls.

8) NBS has established a calibration service for ASTM E 127 - type reference blocks. This system compares the responses of the blocks being calibrated to the response of an interim standard reference block using prescribed equipment and procedures.

9) Plans for a "loaner service" of well characterized blocks, to be available to the ultrasonic community, are underway. This will be formalized into a Measurement Assurance Program to assess the adequacy of the entire measurement system.

Appendix A

Residual Stress Measurement, NBS Aluminum Block

RESIDUAL STRESS MEASUREMENTS

NBS AL. BLOCK, SURFACE S4/1, METALLOGRAPHICALLY POLISHED

YOUNG'S MODULUS =  $7.2E+10$  N/M<sup>2</sup>;  $7.3E+03$  KG/MM<sup>2</sup>;  $1.04E+07$  PD/IN<sup>2</sup>

POISSON'S RATIO = .33

STRESS COMPONENT =  $-1.1E+08$  N/M<sup>2</sup>;  $-1.2E+01$  KG/MM<sup>2</sup>;  $-1.7E+04$  PD/IN<sup>2</sup>

THIS IS A COMPRESSIVE STRESS IN THE PLANE OF THE SURFACE.

DELTA 2\*THETA FITTED TO LSE STRAIGHT LINE:

$$\text{DEL 2TH} = ( 1.11935 ) * (\text{SIN PSI})^2 + ( -5.74014E-2 )$$

| ANGLE OF INCLINATION | 2-THETA | SIN <sup>2</sup> | DEL 2TH | LSE FIT |
|----------------------|---------|------------------|---------|---------|
| 0                    | 155.405 | .000             | .000    | -.057   |
| 15                   | 155.476 | .067             | .071    | .018    |
| 30                   | 155.563 | .250             | .158    | .222    |
| 45                   | 155.718 | .500             | .313    | .502    |
| 60                   | 156.330 | .750             | .925    | .782    |

PROBABLE ERROR OF LINEAR FIT = .101

STANDARD DEVIATION OF STRESS =  $2.5E+07$  N/M<sup>2</sup>

RELATIVE STAND. DEV. OF STRESS = 21.3 PER CENT

RESIDUAL STRESS MEASUREMENTS

NBS AL. BLOCK, SURFACE S4/1, ETCHED 3 MIN, 10% NACH, 60-65 DEGS C.

YOUNG'S MODULUS =  $7.2E+10$  N/M<sup>2</sup>;  $7.3E+03$  KG/MM<sup>2</sup>;  $1.04E+07$  PD/IN<sup>2</sup>

POISSON'S RATIO = .33

STRESS COMPONENT =  $-4.3E+07$  N/M<sup>2</sup>;  $-4.4E+00$  KG/MM<sup>2</sup>;  $-6.2E+03$  PD/IN<sup>2</sup>

THIS IS A COMPRESSIVE STRESS IN THE PLANE OF THE SURFACE.

DELTA 2\*THETA FITTED TO LSE STRAIGHT LINE:

$$\text{DEL 2TH} = ( .418597 ) * (\text{SIN PSI})^2 + ( .119019 )$$

| ANGLE OF INCLINATION | 2-THETA | SIN <sup>2</sup> | DEL 2TH | LSE FIT |
|----------------------|---------|------------------|---------|---------|
| 0                    | 155.357 | .000             | .000    | .119    |
| 15                   | 155.497 | .067             | .140    | .147    |
| 30                   | 155.743 | .250             | .386    | .224    |
| 45                   | 155.737 | .500             | .380    | .328    |
| 60                   | 155.755 | .750             | .398    | .433    |
| 60                   | 155.737 | .750             | .380    | .433    |

PROBABLE ERROR OF LINEAR FIT = .073

STANDARD DEVIATION OF STRESS =  $1.5E+07$  N/M<sup>2</sup>

RELATIVE STAND. DEV. OF STRESS = 35.1 PER CENT

RESIDUAL STRESS MEASUREMENTS

NBS AL. BLOCK, SURFACE S5/2, METALLOGRAPHICALLY POLISHED

YOUNG'S MODULUS =  $7.2E+10$  N/M<sup>2</sup>;  $7.3E+03$  KG/MM<sup>2</sup>;  $1.04E+07$  PD/IN<sup>2</sup>

POISSON'S RATIO = .33

STRESS COMPONENT =  $-1.2E+08$  N/M<sup>2</sup>;  $-1.2E+01$  KG/MM<sup>2</sup>;  $-1.7E+04$  PD/IN<sup>2</sup>

THIS IS A COMPRESSIVE STRESS IN THE PLANE OF THE SURFACE.

DELTA 2\*THETA FITTED TO LSE STRAIGHT LINE:

$$\text{DEL 2TH} = ( 1.14178 ) * (\text{SIN PSI})^2 + (-.038433 )$$

| ANGLE OF INCLINATION | 2-THETA | SIN <sup>2</sup> | DEL 2TH | LSE FIT |
|----------------------|---------|------------------|---------|---------|
| 0                    | 155.422 | .000             | .000    | -.038   |
| 15                   | 155.511 | .067             | .089    | .038    |
| 30                   | 155.630 | .250             | .208    | .247    |
| 45                   | 155.778 | .500             | .356    | .532    |
| 60                   | 156.366 | .750             | .944    | .818    |

PROBABLE ERROR OF LINEAR FIT = .089

STANDARD DEVIATION OF STRESS =  $2.2E+07$  N/M<sup>2</sup>

RELATIVE STAND. DEV. OF STRESS = 18.6 PER CENT

RESIDUAL STRESS MEASUREMENTS

NBS AL. BLOCK, SURFACE S5/2, ETCHED 3 MIN, 10% NACH, 60-65 DEGS C.

YOUNG'S MODULUS =  $7.2E+10$  N/M<sup>2</sup>;  $7.3E+03$  KG/MM<sup>2</sup>;  $1.04E+07$  PD/IN<sup>2</sup>

POISSON'S RATIO = .33

STRESS COMPONENT =  $-4.7E+07$  N/M<sup>2</sup>;  $-4.8E+00$  KG/MM<sup>2</sup>;  $-6.9E+03$  PD/IN<sup>2</sup>

THIS IS A COMPRESSIVE STRESS IN THE PLANE OF THE SURFACE.

DELTA 2\*THETA FITTED TO LSE STRAIGHT LINE:

$$\text{DEL 2TH} = ( .462704 ) * (\text{SIN PSI})^2 + (-2.21212E-2 )$$

| ANGLE OF INCLINATION | 2-THETA | SIN <sup>2</sup> | DEL 2TH | LSE FIT |
|----------------------|---------|------------------|---------|---------|
| 0                    | 155.400 | .000             | .000    | -.022   |
| 15                   | 155.507 | .067             | .107    | .009    |
| 30                   | 155.414 | .250             | .014    | .094    |
| 30                   | 155.410 | .250             | .010    | .094    |
| 45                   | 155.601 | .500             | .201    | .209    |
| 60                   | 155.776 | .750             | .376    | .325    |

PROBABLE ERROR OF LINEAR FIT = .055

STANDARD DEVIATION OF STRESS =  $1.3E+07$  N/M<sup>2</sup>

RELATIVE STAND. DEV. OF STRESS = 27.9 PER CENT

## Appendix B

### Residual Stress Measurement on Rejected Steel Block

RESIDUAL STRESS MEASUREMENTS

STEEL BLOCK SURFACE S1, AS RECEIVED

YOUNG'S MODULUS =  $2.1E+11$  N/M<sup>2</sup>;  $2.1E+04$  KG/MM<sup>2</sup>;  $3.00E+07$  PD/IN<sup>2</sup>

POISSON'S RATIO = .30

STRESS COMPONENT =  $-2.2E+08$  N/M<sup>2</sup>;  $-2.3E+01$  KG/MM<sup>2</sup>;  $-3.2E+04$  PD/IN<sup>2</sup>

THIS IS A COMPRESSIVE STRESS IN THE PLANE OF THE SURFACE.

DELTA 2\*THETA FITTED TO LSE STRAIGHT LINE:

$$\text{DEL 2TH} = ( .739685 ) * (\text{SIN PSI})^2 + ( 4.69848E-2 )$$

| ANGLE OF INCLINATION | 2-THETA | SIN <sup>2</sup> | DEL 2TH | LSE FIT |
|----------------------|---------|------------------|---------|---------|
| 0                    | 155.518 | .000             | .000    | .047    |
| 15                   | 155.625 | .067             | .107    | .097    |
| 30                   | 155.778 | .250             | .260    | .232    |
| 45                   | 155.991 | .500             | .473    | .417    |
| 60                   | 156.072 | .750             | .554    | .602    |

PROBABLE ERROR OF LINEAR FIT = .036

STANDARD DEVIATION OF STRESS =  $2.6E+07$  N/M<sup>2</sup>

RELATIVE STAND. DEV. OF STRESS = 11.6 PER CENT

RESIDUAL STRESS MEASUREMENTS

STEEL BLOCK SURFACE S1, POLISHED METALLOGRAPHICALLY THROUGH 600 GIRD SIC

YOUNG'S MODULUS =  $2.1E+11$  N/M<sup>2</sup>;  $2.1E+04$  KG/MM<sup>2</sup>;  $3.00E+07$  PD/IN<sup>2</sup>

POISSON'S RATIO = .30

STRESS COMPONENT =  $-4.1E+08$  N/M<sup>2</sup>;  $-4.1E+01$  KG/MM<sup>2</sup>;  $-5.9E+04$  PD/IN<sup>2</sup>

THIS IS A COMPRESSIVE STRESS IN THE PLANE OF THE SURFACE.

DELTA 2\*THETA FITTED TO LSE STRAIGHT LINE:

$$\text{DEL 2TH} = ( 1.33784 ) * (\text{SIN PSI})^2 + ( 3.40231E-2 )$$

| ANGLE OF INCLINATION | 2-THETA | SIN <sup>2</sup> | DEL 2TH | LSE FIT |
|----------------------|---------|------------------|---------|---------|
| 0                    | 155.322 | .000             | .000    | .034    |
| 0                    | 155.302 | .000             | -.020   | .034    |
| 15                   | 155.503 | .067             | .181    | .124    |
| 15                   | 155.486 | .067             | .164    | .124    |
| 30                   | 155.738 | .250             | .416    | .368    |
| 30                   | 155.704 | .250             | .382    | .368    |
| 45                   | 155.961 | .500             | .639    | .703    |
| 45                   | 155.964 | .500             | .642    | .703    |
| 60                   | 156.378 | .750             | 1.056   | 1.037   |
| 60                   | 156.395 | .750             | 1.073   | 1.037   |

PROBABLE ERROR OF LINEAR FIT = .034

STANDARD DEVIATION OF STRESS =  $1.8E+07$  N/M<sup>2</sup>

RELATIVE STAND. DEV. OF STRESS = 4.3 PER CENT

RESIDUAL STRESS MEASUREMENTS

STEEL BLOCK SURFACE S1, METALLOGRAPHICALLY POLISHED

YOUNG'S MODULUS =  $2.1E+11$  N/M<sup>2</sup>;  $2.1E+04$  KG/MM<sup>2</sup>;  $3.00E+07$  PD/IN<sup>2</sup>

POISSON'S RATIO = .30

STRESS COMPONENT =  $-2.4E+08$  N/M<sup>2</sup>;  $-2.4E+01$  KG/MM<sup>2</sup>;  $-3.4E+04$  PD/IN<sup>2</sup>

THIS IS A COMPRESSIVE STRESS IN THE PLANE OF THE SURFACE.

DELTA 2\*THETA FITTED TO LSE STRAIGHT LINE:

$$\text{DEL 2TH} = (.78451) * (\text{SIN PSI})^2 + (1.29358E-2)$$

| ANGLE OF INCLINATION | 2-THETA | SIN <sup>2</sup> | DEL 2TH | LSE FIT |
|----------------------|---------|------------------|---------|---------|
| 0                    | 155.575 | .000             | .000    | .013    |
| 15                   | 155.642 | .067             | .067    | .065    |
| 30                   | 155.800 | .250             | .225    | .209    |
| 45                   | 155.983 | .500             | .408    | .405    |
| 60                   | 156.169 | .750             | .594    | .601    |

PROBABLE ERROR OF LINEAR FIT = .009

STANDARD DEVIATION OF STRESS =  $6.1E+06$  N/M<sup>2</sup>

RELATIVE STAND. DEV. OF STRESS = 2.6 PER CENT

RESIDUAL STRESS MEASUREMENTS

STEEL BLOCK SURFACE S1, ETCHED 5% NITAL TO REMOVE .001 IN.

YOUNG'S MODULUS =  $2.1E+11$  N/M<sup>2</sup>;  $2.1E+04$  KG/MM<sup>2</sup>;  $3.00E+07$  PD/IN<sup>2</sup>

POISSON'S RATIO = .30

STRESS COMPONENT =  $-7.7E+07$  N/M<sup>2</sup>;  $-7.9E+00$  KG/MM<sup>2</sup>;  $-1.1E+04$  PD/IN<sup>2</sup>

THIS IS A COMPRESSIVE STRESS IN THE PLANE OF THE SURFACE.

DELTA 2\*THETA FITTED TO LSE STRAIGHT LINE:

$$\text{DEL 2TH} = (.258463) * (\text{SIN PSI})^2 + (3.11982E-2)$$

| ANGLE OF INCLINATION | 2-THETA | SIN <sup>2</sup> | DEL 2TH | LSE FIT |
|----------------------|---------|------------------|---------|---------|
| 0                    | 155.764 | .000             | .000    | .031    |
| 15                   | 155.823 | .067             | .059    | .049    |
| 30                   | 155.880 | .250             | .116    | .096    |
| 45                   | 155.949 | .500             | .185    | .160    |
| 60                   | 155.965 | .750             | .201    | .225    |

PROBABLE ERROR OF LINEAR FIT = .020

STANDARD DEVIATION OF STRESS =  $1.4E+07$  N/M<sup>2</sup>

RELATIVE STAND. DEV. OF STRESS = 18.5 PER CENT

RESIDUAL STRESS MEASUREMENTS

STEEL BLOCK SURFACE S1, ELECTROPOLISHED TO REMOVED .002 IN.

YOUNG'S MODULUS = 2.1E+11 N/M<sup>2</sup>; 2.1E+04 KG/MM<sup>2</sup>; 3.00E+07 PD/IN<sup>2</sup>

POISSON'S RATIO = .30

STRESS COMPONENT=-3.5E+07 N/M<sup>2</sup>; -3.5E+00 KG/MM<sup>2</sup>; -5.0E+03 PD/IN<sup>2</sup>

THIS IS A COMPRESSIVE STRESS IN THE PLANE OF THE SURFACE.

DELTA 2\*THETA FITTED TO LSE STRAIGHT LINE:

$$\text{DEL 2TH} = ( .116285 ) * (\text{SIN PSI})^2 + ( 3.74838E-2 )$$

| ANGLE OF INCLINATION | 2-THETA | SIN <sup>2</sup> | DEL 2TH | LSE FIT |
|----------------------|---------|------------------|---------|---------|
| 0                    | 155.767 | .000             | .000    | .037    |
| 0                    | 155.767 | .000             | .000    | .037    |
| 15                   | 155.819 | .067             | .052    | .045    |
| 30                   | 155.871 | .250             | .104    | .067    |
| 30                   | 155.866 | .250             | .099    | .067    |
| 45                   | 155.903 | .500             | .136    | .096    |
| 45                   | 155.889 | .500             | .122    | .096    |
| 60                   | 155.854 | .750             | .087    | .125    |
| 60                   | 155.861 | .750             | .094    | .125    |

PROBABLE ERROR OF LINEAR FIT = .026

STANDARD DEVIATION OF STRESS = 1.3E+07 N/M<sup>2</sup>

RELATIVE STAND. DEV. OF STRESS = 38.6 PER CENT

RESIDUAL STRESS MEASUREMENTS

STEEL BLOCK SURFACE S2/1, MACHINED

YOUNG'S MODULUS = 2.1E+11 N/M<sup>2</sup>; 2.1E+04 KG/MM<sup>2</sup>; 3.00E+07 PD/IN<sup>2</sup>

POISSON'S RATIO = .30

STRESS COMPONENT=-3.5E+08 N/M<sup>2</sup>; -3.6E+01 KG/MM<sup>2</sup>; -5.1E+04 PD/IN<sup>2</sup>

THIS IS A COMPRESSIVE STRESS IN THE PLANE OF THE SURFACE.

DELTA 2\*THETA FITTED TO LSE STRAIGHT LINE:

$$\text{DEL 2TH} = ( 1.17328 ) * (\text{SIN PSI})^2 + ( -3.10448E-3 )$$

| ANGLE OF INCLINATION | 2-THETA | SIN <sup>2</sup> | DEL 2TH | LSE FIT |
|----------------------|---------|------------------|---------|---------|
| 0                    | 155.489 | .000             | .000    | -.003   |
| 15                   | 155.564 | .067             | .075    | .075    |
| 30                   | 155.783 | .250             | .294    | .290    |
| 45                   | 156.057 | .500             | .568    | .584    |
| 60                   | 156.375 | .750             | .886    | .877    |

PROBABLE ERROR OF LINEAR FIT = .007

STANDARD DEVIATION OF STRESS = 5.2E+06 N/M<sup>2</sup>

RELATIVE STAND. DEV. OF STRESS = 1.5 PER CENT

RESIDUAL STRESS MEASUREMENTS

STEEL BLOCK SURFACE S2/2, MACHINED

YOUNG'S MODULUS = 2.1E+11 N/M<sup>2</sup>; 2.1E+04 KG/MM<sup>2</sup>; 3.00E+07 PD/IN<sup>2</sup>

POISSON'S RATIO = .30

STRESS COMPONENT=-1.6E+08 N/M<sup>2</sup>; -1.6E+01 KG/MM<sup>2</sup>; -2.3E+04 PD/IN<sup>2</sup>

THIS IS A COMPRESSIVE STRESS IN THE PLANE OF THE SURFACE.

DELTA 2\*THETA FITTED TO LSE STRAIGHT LINE:

$$\text{DEL 2TH} = ( .533885 ) * (\text{SIN PSI})^2 + ( -4.31723E-3 )$$

| ANGLE OF INCLINATION | 2-THETA | SIN <sup>2</sup> | DEL 2TH | LSE FIT |
|----------------------|---------|------------------|---------|---------|
| 0                    | 155.654 | .000             | .000    | -.004   |
| 15                   | 155.688 | .067             | .034    | .031    |
| 30                   | 155.767 | .250             | .113    | .129    |
| 45                   | 155.929 | .500             | .275    | .263    |
| 60                   | 156.047 | .750             | .393    | .396    |

PROBABLE ERROR OF LINEAR FIT = .008

STANDARD DEVIATION OF STRESS = 5.9E+06 N/M<sup>2</sup>

RELATIVE STAND. DEV. OF STRESS = 3.7 PER CENT

RESIDUAL STRESS MEASUREMENTS

STEEL BLOCK SURFACE S2/2, METALLOGRAPHICALLY POLISHED

YOUNG'S MODULUS = 2.1E+11 N/M<sup>2</sup>; 2.1E+04 KG/MM<sup>2</sup>; 3.00E+07 PD/IN<sup>2</sup>

POISSON'S RATIO = .30

STRESS COMPONENT=-3.1E+08 N/M<sup>2</sup>; -3.2E+01 KG/MM<sup>2</sup>; -4.5E+04 PD/IN<sup>2</sup>

THIS IS A COMPRESSIVE STRESS IN THE PLANE OF THE SURFACE.

DELTA 2\*THETA FITTED TO LSE STRAIGHT LINE:

$$\text{DEL 2TH} = ( 1.02396 ) * (\text{SIN PSI})^2 + ( 8.69558E-3 )$$

| ANGLE OF INCLINATION | 2-THETA | SIN <sup>2</sup> | DEL 2TH | LSE FIT |
|----------------------|---------|------------------|---------|---------|
| 0                    | 155.477 | .000             | .000    | .009    |
| 15                   | 155.573 | .067             | .096    | .077    |
| 30                   | 155.735 | .250             | .258    | .265    |
| 45                   | 155.986 | .500             | .509    | .521    |
| 60                   | 156.262 | .750             | .785    | .777    |

PROBABLE ERROR OF LINEAR FIT = .010

STANDARD DEVIATION OF STRESS = 7.3E+06 N/M<sup>2</sup>

RELATIVE STAND. DEV. OF STRESS = 2.4 PER CENT

RESIDUAL STRESS MEASUREMENTS

STEEL BLOCK SURFACE S2/2, ETCHED S% NITAL TO REMOVE .001 IN.

YOUNG'S MODULUS = 2.1E+11 N/M<sup>2</sup>; 2.1E+04 KG/MM<sup>2</sup>; 3.00E+07 PD/IN<sup>2</sup>

POISSON'S RATIO = .30

STRESS COMPONENT= 8.0E+06 N/M<sup>2</sup>; 8.1E-01 KG/MM<sup>2</sup>; 1.2E+03 PD/IN<sup>2</sup>

THIS IS A TENSILE STRESS IN THE PLANE OF THE SURFACE.

DELTA 2\*THETA FITTED TO LSE STRAIGHT LINE:

$$\text{DEL 2TH} = (-2.68746E-2) * (\text{SIN PSI})^2 + (2.76229E-2)$$

| ANGLE OF INCLINATION | 2-THETA | SIN <sup>2</sup> | DEL 2TH | LSE FIT |
|----------------------|---------|------------------|---------|---------|
| 0                    | 155.890 | .000             | .000    | .028    |
| 15                   | 155.937 | .067             | .047    | .026    |
| 30                   | 155.926 | .250             | .036    | .021    |
| 45                   | 155.899 | .500             | .009    | .014    |
| 60                   | 155.894 | .750             | .004    | .007    |

PROBABLE ERROR OF LINEAR FIT = .015

STANDARD DEVIATION OF STRESS = 1.1E+07 N/M<sup>2</sup>

RELATIVE STAND. DEV. OF STRESS =132.5 PER CENT

RESIDUAL STRESS MEASUREMENTS

STEEL BLOCK SURFACE S2/2, ELECTROPOLISHED TO REMOVED .002 IN.

YOUNG'S MODULUS = 2.1E+11 N/M<sup>2</sup>; 2.1E+04 KG/MM<sup>2</sup>; 3.00E+07 PD/IN<sup>2</sup>

POISSON'S RATIO = .30

STRESS COMPONENT=-3.1E+06 N/M<sup>2</sup>; -3.2E-01 KG/MM<sup>2</sup>; -4.5E+02 PD/IN<sup>2</sup>

THIS IS A COMPRESSIVE STRESS IN THE PLANE OF THE SURFACE.

DELTA 2\*THETA FITTED TO LSE STRAIGHT LINE:

$$\text{DEL 2TH} = (1.04798E-2) * (\text{SIN PSI})^2 + (4.04165E-2)$$

| ANGLE OF INCLINATION | 2-THETA | SIN <sup>2</sup> | DEL 2TH | LSE FIT |
|----------------------|---------|------------------|---------|---------|
| 0                    | 155.842 | .000             | .000    | .040    |
| 0                    | 155.843 | .000             | .001    | .040    |
| 15                   | 155.889 | .067             | .047    | .041    |
| 15                   | 155.886 | .067             | .044    | .041    |
| 30                   | 155.926 | .250             | .084    | .043    |
| 30                   | 155.919 | .250             | .077    | .043    |
| 45                   | 155.916 | .500             | .074    | .046    |
| 45                   | 155.925 | .500             | .083    | .046    |
| 60                   | 155.859 | .750             | .017    | .048    |
| 60                   | 155.852 | .750             | .010    | .048    |

PROBABLE ERROR OF LINEAR FIT = .025

STANDARD DEVIATION OF STRESS = 1.2E+07 N/M<sup>2</sup>

RELATIVE STAND. DEV. OF STRESS =396.0 PER CENT

RESIDUAL STRESS MEASUREMENTS

STEEL BLOCK SURFACE S3/2, METALLOGRAPHICALLY POLISHED

YOUNG'S MODULUS =  $2.1E+11$  N/M<sup>2</sup>;  $2.1E+04$  KG/MM<sup>2</sup>;  $3.00E+07$  PD/IN<sup>2</sup>

POISSON'S RATIO = .30

STRESS COMPONENT =  $-2.6E+08$  N/M<sup>2</sup>;  $-2.6E+01$  KG/MM<sup>2</sup>;  $-3.8E+04$  PD/IN<sup>2</sup>

THIS IS A COMPRESSIVE STRESS IN THE PLANE OF THE SURFACE.

DELTA 2\*THETA FITTED TO LSE STRAIGHT LINE:

$$\text{DEL 2TH} = (.859839) * (\text{SIN PSI})^2 + (1.16137E-2)$$

| ANGLE OF INCLINATION | 2-THETA | SIN <sup>2</sup> | DEL 2TH | LSE FIT |
|----------------------|---------|------------------|---------|---------|
| 0                    | 155.471 | .000             | .000    | .012    |
| 15                   | 155.554 | .067             | .083    | .069    |
| 30                   | 155.695 | .250             | .224    | .227    |
| 30                   | 155.700 | .250             | .229    | .227    |
| 45                   | 155.910 | .500             | .439    | .442    |
| 60                   | 156.128 | .750             | .657    | .656    |

PROBABLE ERROR OF LINEAR FIT = .006

STANDARD DEVIATION OF STRESS =  $4.5E+06$  N/M<sup>2</sup>

RELATIVE STAND. DEV. OF STRESS = 1.7 PER CENT

RESIDUAL STRESS MEASUREMENTS

STEEL BLOCK SURFACE S3/2, ETCHED 5% NITAL

YOUNG'S MODULUS =  $2.1E+11$  N/M<sup>2</sup>;  $2.1E+04$  KG/MM<sup>2</sup>;  $3.00E+07$  PD/IN<sup>2</sup>

POISSON'S RATIO = .30

STRESS COMPONENT =  $-2.6E+08$  N/M<sup>2</sup>;  $-2.7E+01$  KG/MM<sup>2</sup>;  $-3.8E+04$  PD/IN<sup>2</sup>

THIS IS A COMPRESSIVE STRESS IN THE PLANE OF THE SURFACE.

DELTA 2\*THETA FITTED TO LSE STRAIGHT LINE:

$$\text{DEL 2TH} = (.8752) * (\text{SIN PSI})^2 + (3.93152E-2)$$

| ANGLE OF INCLINATION | 2-THETA | SIN <sup>2</sup> | DEL 2TH | LSE FIT |
|----------------------|---------|------------------|---------|---------|
| 0                    | 155.467 | .000             | .000    | .039    |
| 15                   | 155.569 | .067             | .102    | .098    |
| 30                   | 155.778 | .250             | .311    | .258    |
| 45                   | 155.945 | .500             | .478    | .477    |
| 60                   | 156.144 | .750             | .677    | .696    |

PROBABLE ERROR OF LINEAR FIT = .027

STANDARD DEVIATION OF STRESS =  $1.9E+07$  N/M<sup>2</sup>

RELATIVE STAND. DEV. OF STRESS = 7.3 PER CENT

RESIDUAL STRESS MEASUREMENTS

STEEL BLOCK SURFACE 54/1, MACHINED

YOUNG'S MODULUS =  $2.1E+11$  N/M<sup>2</sup>;  $2.1E+04$  KG/MM<sup>2</sup>;  $3.00E+07$  PD/IN<sup>2</sup>

POISSON'S RATIO = .30

STRESS COMPONENT =  $-3.8E+08$  N/M<sup>2</sup>;  $-3.8E+01$  KG/MM<sup>2</sup>;  $-5.4E+04$  PD/IN<sup>2</sup>

THIS IS A COMPRESSIVE STRESS IN THE PLANE OF THE SURFACE.

DELTA 2\*THETA FITTED TO LSE STRAIGHT LINE:

$$\text{DEL 2TH} = ( 1.23884 ) * (\text{SIN P51})^2 + ( 6.37494E-2 )$$

| ANGLE OF INCLINATION | 2-THETA | SIN <sup>2</sup> | DEL 2TH | LSE FIT |
|----------------------|---------|------------------|---------|---------|
| 0                    | 155.398 | .000             | .000    | .064    |
| 15                   | 155.580 | .067             | .182    | .147    |
| 30                   | 155.798 | .250             | .400    | .373    |
| 45                   | 156.123 | .500             | .725    | .683    |
| 60                   | 156.351 | .750             | .953    | .993    |

PROBABLE ERROR OF LINEAR FIT = .038

STANDARD DEVIATION OF STRESS =  $2.7E+07$  N/M<sup>2</sup>

RELATIVE STAND. DEV. OF STRESS = 7.2 PER CENT

RESIDUAL STRESS MEASUREMENTS

STEEL BLOCK SURFACE 54/1, METALLOGRAPHICALLY POLISHED

YOUNG'S MODULUS =  $2.1E+11$  N/M<sup>2</sup>;  $2.1E+04$  KG/MM<sup>2</sup>;  $3.00E+07$  PD/IN<sup>2</sup>

POISSON'S RATIO = .30

STRESS COMPONENT =  $-2.9E+08$  N/M<sup>2</sup>;  $-2.9E+01$  KG/MM<sup>2</sup>;  $-4.2E+04$  PD/IN<sup>2</sup>

THIS IS A COMPRESSIVE STRESS IN THE PLANE OF THE SURFACE.

DELTA 2\*THETA FITTED TO LSE STRAIGHT LINE:

$$\text{DEL 2TH} = ( .954174 ) * (\text{SIN P51})^2 + ( 5.37637E-2 )$$

| ANGLE OF INCLINATION | 2-THETA | SIN <sup>2</sup> | DEL 2TH | LSE FIT |
|----------------------|---------|------------------|---------|---------|
| 0                    | 155.440 | .000             | .000    | .054    |
| 15                   | 155.592 | .067             | .152    | .118    |
| 30                   | 155.774 | .250             | .334    | .292    |
| 45                   | 155.955 | .500             | .515    | .531    |
| 60                   | 156.203 | .750             | .763    | .769    |

PROBABLE ERROR OF LINEAR FIT = .030

STANDARD DEVIATION OF STRESS =  $2.2E+07$  N/M<sup>2</sup>

RELATIVE STAND. DEV. OF STRESS = 7.6 PER CENT

RESIDUAL STRESS MEASUREMENTS

STEEL BLOCK SURFACE S4/1, ELECTROPOLISHED TC REMOVED .001 IN.

YOUNG'S MODULUS = 2.1E+11 N/M<sup>2</sup>; 2.1E+04 KG/MM<sup>2</sup>; 3.00E+07 PD/IN<sup>2</sup>

POISSON'S RATIO = .30

STRESS COMPONENT = 2.8E+07 N/M<sup>2</sup>; 2.9E+00 KG/MM<sup>2</sup>; 4.1E+03 PD/IN<sup>2</sup>

THIS IS A TENSILE STRESS IN THE PLANE OF THE SURFACE.

DELTA 2\*THETA FITTED TO LSE STRAIGHT LINE:

$$\text{DEL 2TH} = (-9.47678E-2) * (\text{SIN PSI})^2 + (4.97008E-2)$$

| ANGLE OF INCLINATION | 2-THETA | SIN <sup>2</sup> | DEL 2TH | LSE FIT |
|----------------------|---------|------------------|---------|---------|
| 0                    | 155.814 | .000             | .000    | .050    |
| 15                   | 155.863 | .067             | .049    | .043    |
| 30                   | 155.877 | .250             | .063    | .026    |
| 45                   | 155.876 | .500             | .062    | .002    |
| 60                   | 155.740 | .750             | -.074   | -.021   |

PROBABLE ERROR OF LINEAR FIT = .039

STANDARD DEVIATION OF STRESS = 2.8E+07 N/M<sup>2</sup>

RELATIVE STAND. DEV. OF STRESS = 98.7 PER CENT

RESIDUAL STRESS MEASUREMENTS

STEEL BLOCK SURFACE S4/1, ELECTROPOLISHED TC REMOVED .0018 IN.

YOUNG'S MODULUS = 2.1E+11 N/M<sup>2</sup>; 2.1E+04 KG/MM<sup>2</sup>; 3.00E+07 PD/IN<sup>2</sup>

POISSON'S RATIO = .30

STRESS COMPONENT = 1.4E+07 N/M<sup>2</sup>; 1.4E+00 KG/MM<sup>2</sup>; 2.0E+03 PD/IN<sup>2</sup>

THIS IS A TENSILE STRESS IN THE PLANE OF THE SURFACE.

DELTA 2\*THETA FITTED TO LSE STRAIGHT LINE:

$$\text{DEL 2TH} = (-4.75223E-2) * (\text{SIN PSI})^2 + (1.50938E-2)$$

| ANGLE OF INCLINATION | 2-THETA | SIN <sup>2</sup> | DEL 2TH | LSE FIT |
|----------------------|---------|------------------|---------|---------|
| 0                    | 155.945 | .000             | .000    | .015    |
| 0                    | 155.946 | .000             | .001    | .015    |
| 15                   | 155.961 | .067             | .016    | .012    |
| 15                   | 155.962 | .067             | .017    | .012    |
| 30                   | 155.960 | .250             | .015    | .003    |
| 30                   | 155.957 | .250             | .012    | .003    |
| 45                   | 155.947 | .500             | .002    | -.009   |
| 45                   | 155.947 | .500             | .002    | -.009   |
| 60                   | 155.950 | .750             | .005    | -.021   |
| 60                   | 155.877 | .750             | -.068   | -.021   |

PROBABLE ERROR OF LINEAR FIT = .015

STANDARD DEVIATION OF STRESS = 7.3E+06 N/M<sup>2</sup>

RELATIVE STAND. DEV. OF STRESS = 52.2 PER CENT

RESIDUAL STRESS MEASUREMENTS

STEEL BLOCK SURFACE S5/2, METALLOGRAPHICALLY POLISHED

YOUNG'S MODULUS = 2.1E+11 N/M<sup>2</sup>; 2.1E+04 KG/MM<sup>2</sup>; 3.00E+07 PD/IN<sup>2</sup>

POISSON'S RATIO = .30

STRESS COMPONENT=-2.1E+08 N/M<sup>2</sup>; -2.1E+01 KG/MM<sup>2</sup>; -3.0E+04 PD/IN<sup>2</sup>

THIS IS A COMPRESSIVE STRESS IN THE PLANE OF THE SURFACE.

DELTA 2\*THETA FITTED TO LSE STRAIGHT LINE:

$$\text{DEL 2TH} = ( .687597 ) * (\text{SIN PSI})^2 + ( 5.10967E-3 )$$

| ANGLE OF INCLINATION | 2-THETA | SIN <sup>2</sup> | DEL 2TH | LSE FIT |
|----------------------|---------|------------------|---------|---------|
| 0                    | 155.574 | .000             | .000    | .005    |
| 15                   | 155.641 | .067             | .067    | .051    |
| 30                   | 155.756 | .250             | .182    | .177    |
| 45                   | 155.885 | .500             | .311    | .349    |
| 60                   | 156.117 | .750             | .543    | .521    |

PROBABLE ERROR OF LINEAR FIT = .018

STANDARD DEVIATION OF STRESS = 1.3E+07 N/M<sup>2</sup>

RELATIVE STAND. DEV. OF STRESS = 6.4 PER CENT

RESIDUAL STRESS MEASUREMENTS

STEEL BLOCK SURFACE S5/2, ELECTROPOLISHED TC REMOVED .001 IN.

YOUNG'S MODULUS = 2.1E+11 N/M<sup>2</sup>; 2.1E+04 KG/MM<sup>2</sup>; 3.00E+07 PD/IN<sup>2</sup>

POISSON'S RATIO = .30

STRESS COMPONENT=-1.3E+07 N/M<sup>2</sup>; -1.3E+00 KG/MM<sup>2</sup>; -1.9E+03 PD/IN<sup>2</sup>

THIS IS A COMPRESSIVE STRESS IN THE PLANE OF THE SURFACE.

DELTA 2\*THETA FITTED TO LSE STRAIGHT LINE:

$$\text{DEL 2TH} = ( 4.29908E-2 ) * (\text{SIN PSI})^2 + ( .040327 )$$

| ANGLE OF INCLINATION | 2-THETA | SIN <sup>2</sup> | DEL 2TH | LSE FIT |
|----------------------|---------|------------------|---------|---------|
| 0                    | 155.820 | .000             | .000    | .040    |
| 15                   | 155.876 | .067             | .056    | .043    |
| 30                   | 155.908 | .250             | .088    | .051    |
| 45                   | 155.894 | .500             | .074    | .062    |
| 60                   | 155.871 | .750             | .051    | .073    |

PROBABLE ERROR OF LINEAR FIT = .024

STANDARD DEVIATION OF STRESS = 1.7E+07 N/M<sup>2</sup>

RELATIVE STAND. DEV. OF STRESS =132.3 PER CENT

RESIDUAL STRESS MEASUREMENTS

STEEL BLOCK SURFACE S5/2, ELECTROPOLISHED TO REMOVED .0018 IN.

YOUNG'S MODULUS =  $2.1E+11$  N/M<sup>2</sup>;  $2.1E+04$  KG/MM<sup>2</sup>;  $3.00E+07$  PD/IN<sup>2</sup>

POISSON'S RATIO = .30

STRESS COMPONENT =  $-5.7E+07$  N/M<sup>2</sup>;  $-5.8E+00$  KG/MM<sup>2</sup>;  $-8.3E+03$  PD/IN<sup>2</sup>

THIS IS A COMPRESSIVE STRESS IN THE PLANE OF THE SURFACE.

DELTA 2\*THETA FITTED TO LSE STRAIGHT LINE:

$$\text{DEL 2TH} = ( .192153 ) * (\text{SIN PSI})^2 + ( 5.26804E-2 )$$

| ANGLE OF<br>INCLINATION | 2-THETA | SIN <sup>2</sup> | DEL 2TH | LSE FIT |
|-------------------------|---------|------------------|---------|---------|
| 0                       | 155.793 | .000             | .000    | .053    |
| 0                       | 155.798 | .000             | .005    | .053    |
| 15                      | 155.859 | .067             | .066    | .066    |
| 15                      | 155.900 | .067             | .107    | .066    |
| 30                      | 155.931 | .250             | .138    | .101    |
| 30                      | 155.930 | .250             | .137    | .101    |
| 45                      | 155.971 | .500             | .178    | .149    |
| 45                      | 155.952 | .500             | .159    | .149    |
| 60                      | 155.960 | .750             | .167    | .197    |
| 60                      | 155.965 | .750             | .172    | .197    |

PROBABLE ERROR OF LINEAR FIT = .026

STANDARD DEVIATION OF STRESS =  $1.3E+07$  N/M<sup>2</sup>

RELATIVE STAND. DEV. OF STRESS = 22.8 PER CENT

## REFERENCES

- [1] Anon., Standard Recommended Practice for Fabricating and Checking Aluminum Alloy Ultrasonic Standard Reference Blocks, ASTM Designation E 127-64, 1974 Annual Book of ASTM Standards, Part 11 (Am Soc Test Mat, Philadelphia, 1974), p. 229.
- [2] Anon., Standard Recommended Practice for Fabrication and Control of Steel Reference blocks Used in Ultrasonic Inspection, ASTM Designation E 428-71, Ibid, p. 489.
- [3] Anon., Standard Recommended Practice for Fabricating and Checking Aluminum Alloy Ultrasonic Standard Reference Blocks, ASTM Designation E 127-75 (available from Am Soc Test Mat, 1916 Race St., Philadelphia, PA, 19103).
- [4] Gulley, Lee R., NDE Horror Stories, in Proceedings of the Interdisciplinary Workshop for Quantitative Flaw Definition, Report No. AFML-TR-74-238, for Air Force Materials Laboratory by Rockwell International Science Center, Thousand Oaks, CA, January 1975.
- [5] Chwirut, D. J., Sushinsky, G. F., and Eitzen, D. G., Procedures for the Calibration of ASTM E 127-Type Ultrasonic Reference Blocks, Report No. NBS TN 924, National Bureau of Standards, Washington, D.C., September 1976.
- [6] Millman, I., An Improved Facility for the Calibration of Aluminum Alloy Ultrasonic Reference Blocks, Report No. AQD/NDT 1369, AQD Labs, Harefield, Uxbridge, Middlesex, U.K.

- [7] Kettering, D. D., Ultrasonic Nondestructive Testing (NDT) Calibration Standards, Report No. ADR 14-04-75.2, Grumman Aerospace Corporation, Bethpage, NY, July 1975.
- [8] Eitzen, D. G., et al, Improved Ultrasonic Standard Reference Blocks, Report No. NBSIR 75-685, National Bureau of Standards, Washington, D.C., April 1975.
- [9] Chaskelis, H. H., Transducers - Fact and Fiction, Non-Destructive Testing, December 1971, p 375.
- [10] Reynolds, P. M. (editor), Proceedings of the Symposium on The Future of Ultrasonic Spectroscopy, sponsored by the British Non-Ferrous Metals Research Assoc., London, England, Oct 14, 1970.
- [11] Paton, N. E., Ultrasonic Samples Using Diffusion Bonding Techniques, in Proceedings of the ARPA/AFML Review of Quantitative NDE, Report No. AFML-TR-75-212, for Air Force Material Laboratory, by Rockwell International Science Center, Thousand Oaks, CA, January, 1976.
- [12] Christenson, A. L., Measurement of Stress by X-rays, Report No. SAE TR-182 (as corrected by enata sheet dated March 11, 1964), Society of Automotive Engineers, New York, NY, 1960.
- [13] Gangulee, A., Separation of  $\alpha_1$ - $\alpha_2$  Doublet in X-ray Profiles, J. Appl. Cryst. 3, 272 (1970).
- [14] Teague, E. Clayton, Evaluation, Revision and Application of the NBS Stylus/Computer System for the Measurement of Surface Roughness, Report No. NBS TN 902, National Bureau of Standards, Washington, D.C., April 1976.