

AD-A042 798

TRACOR SCIENCES AND SYSTEMS AUSTIN TEX
PRELIMINARY DESIGN OF AN AIRCRAFT NOISE MEASUREMENT SYSTEM FOR --ETC(U)

F/G 1/3

JAN 77 B K COOPER

DOT-FATGWA-3900

UNCLASSIFIED

TRACOR-T75-AU-9531U

FAA-RD-75-217

NL

1 OF 3

AD
A042798



REPORT NO. FAA-RD-75-217

12

AD A 042798

PRELIMINARY DESIGN OF AN AIRCRAFT NOISE MEASUREMENT SYSTEM FOR CERTIFICATION AND RESEARCH



DDC
AUG 9 1977

January 1977

FINAL TASK B REPORT

Document is available to the U.S. public through
the National Technical Information Service,
Springfield, Virginia 22161.

Prepared for

U.S. DEPARTMENT OF TRANSPORTATION
FEDERAL AVIATION ADMINISTRATION
Systems Research & Development Service
Washington, D.C. 20590

AD No. _____
DDC FILE COPY

NOTICE

This document is disseminated under the sponsorship of the Department of Transportation in the interest of information exchange. The United States Government assumes no liability for its contents or use thereof.

Technical Report Documentation Page

1. Report No. 18 FAA-RD-75-217		2. Government Accession No.		3. Recipient's Catalog No. 11	
4. Title and Subtitle 6 Preliminary Design of an Aircraft Noise Measurement System for Certification and Research				5. Report Date January 1977	
7. Author(s) 10 B. K. Cooper				8. Performing Organization Report No. 14 TRACOR-T75-AU-9531U	
9. Performing Organization Name and Address Tracor Sciences & Systems 6500 Tracor Lane Austin, Texas 78721				10. Work Unit No. (TRAIS)	
12. Sponsoring Agency Name and Address Federal Aviation Administration Systems Research and Development Service 800 Independence Avenue, S.W. Washington, D. C. 20591				11. Contract or Grant No. 15 DOT-FATOWA-3900 <i>new</i>	
15. Supplementary Notes 12 226p.				13. Type of Report and Period Covered 9 Final Report, Task B Sep. 1976-Dec. 1977 <i>OK</i>	
16. Abstract System requirements are presented for a noise measurement system capable of performing tests conforming to FAR Part 36 and for a research noise measurement system applicable to a broad range of objectives. The characteristics of subsystems for the functions of acoustical data collection, aircraft tracking, weather data collection, aircraft performance data collection, and data processing are discussed. Alternative subsystems representative of a range of performance capabilities and costs are considered in terms of specific measurement objectives and other factors. Example system configurations for both certification and research applications are described. The study emphasizes conceptual design rather than detailed equipment/system specifications.				14. Sponsoring Agency Code ARD-550 <i>Task B</i>	
17. Key Words Noise Noise measurement facility Aircraft tracking Acoustics			18. Distribution Statement Document is available to the public through the National Technical Information Service, Springfield, Virginia 22151		
19. Security Classif. (of this report) UNCLASSIFIED		20. Security Classif. (of this page) UNCLASSIFIED		21. No. of Pages 232	22. Price

DDC
APPROVED
AUG 9 1977
RESERVED
C

1 408740

JP

METRIC CONVERSION FACTORS

Approximate Conversions to Metric Measures

Symbol	When You Know	Multiply by	To Find	Symbol
LENGTH				
in	inches	2.5	centimeters	cm
ft	feet	30	meters	m
yd	yards	0.9	kilometers	km
mi	miles	1.6		
AREA				
in ²	square inches	6.5	square centimeters	cm ²
ft ²	square feet	0.09	square meters	m ²
yd ²	square yards	0.8	square kilometers	km ²
mi ²	square miles	2.6	hectares	ha
MASS (weight)				
oz	ounces	28	grams	g
lb	pounds	0.45	kilograms	kg
	short tons (2000 lb)	0.9	tonnes	t
VOLUME				
tsp	teaspoons	5	milliliters	ml
Tbsp	tablespoons	15	milliliters	ml
fl oz	fluid ounces	30	milliliters	ml
c	cups	0.24	liters	l
pt	pints	0.47	liters	l
qt	quarts	0.95	liters	l
gal	gallons	3.8	liters	l
ft ³	cubic feet	0.03	cubic meters	m ³
yd ³	cubic yards	0.76	cubic meters	m ³
TEMPERATURE (exact)				
°F	Fahrenheit temperature	5/9 (after subtracting 32)	Celsius temperature	°C

Symbol	When You Know	Multiply by	To Find	Symbol
LENGTH				
mm	millimeters	0.04	inches	in
cm	centimeters	0.4	inches	in
m	meters	3.3	feet	ft
mi	meters	1.1	yards	yd
km	kilometers	0.6	miles	mi
AREA				
cm ²	square centimeters	0.16	square inches	in ²
m ²	square meters	1.2	square yards	yd ²
km ²	square kilometers	0.4	square miles	mi ²
ha	hectares (10,000 m ²)	2.5	acres	
MASS (weight)				
g	grams	0.035	ounces	oz
kg	kilograms	2.2	pounds	lb
t	tonnes (1000 kg)	1.1	short tons	
VOLUME				
ml	milliliters	0.03	fluid ounces	fl oz
l	liters	2.1	pints	pt
l	liters	1.06	quarts	qt
l	liters	0.26	gallons	gal
m ³	cubic meters	35	cubic feet	ft ³
m ³	cubic meters	1.3	cubic yards	yd ³
TEMPERATURE (exact)				
°C	Celsius temperature	9/5 (then add 32)	Fahrenheit temperature	°F

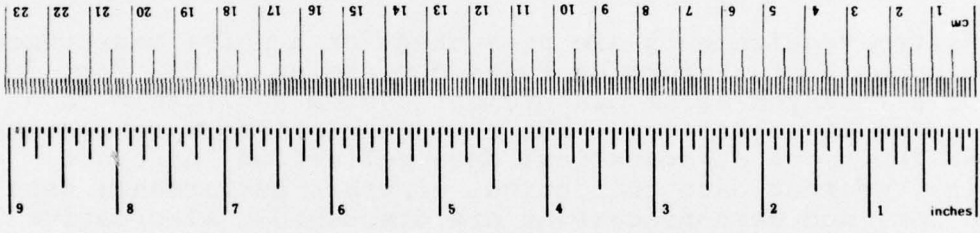

*1 in = 2.54 (exact). For other exact conversions and more detailed tables, see NBS Misc. Publ. 286, Units of Weights and Measures, Price \$2.25, SD Catalog No. C13.10.286.

TABLE OF CONTENTS

<u>Section</u>		<u>Page</u>
	METRIC CONVERSION FACTORS	iii
	LIST OF ILLUSTRATIONS	viii
	LIST OF TABLES	xi
	LIST OF ABBREVIATIONS	xii
1.0	INTRODUCTION	1-1
2.0	GENERAL DESIGN CONSIDERATIONS	2-1
2.1	Basic System Requirements	2-1
2.2	Certification Noise Measurement System Considerations	2-4
2.2.1	General Design Considerations	2-4
2.2.2	FAR Part 36 Requirements	2-4
2.3	Research System	2-9
2.3.1	Typical Research Applications	2-9
2.3.2	Operational System Design Considerations for a Research System	2-11
2.3.3	Applicable Standards	2-13
3.0	ACOUSTICAL DATA SUBSYSTEMS	3-1
3.1	Performance Requirements	3-1
3.1.1	Certification System	3-1
3.1.2	Research System	3-2
3.2	Equipment Configurations	3-4
3.2.1	Portable Tape Recorder Acoustical Data Subsystem	3-4
3.2.2	Multi-Track Tape Recorder Acoustical Data Subsystem	3-7
3.2.3	Real Time Remote Analyzer System	3-11
3.2.4	Real Time Compressed Data System	3-14
3.3	One-Third Octave Band Spectrum Analysis Equipment	3-20
3.3.1	Performance Requirements	3-23

ACCESSION for

NTIS Write Section

DDC Buff Section

UNANNOUNCED

JUSTIFICATION _____

BY _____

DISTRIBUTION/AVAILABILITY CODES

SPECIAL

A

TABLE OF CONTENTS - Continued

<u>Section</u>		<u>Page</u>
3.4	Acoustical Data Subsystem Comparisons	3-25
4.0	TRACKING DATA SUBSYSTEMS	4-1
4.1	Performance Requirements	4-2
4.1.1	Certification System	4-3
4.1.2	Research System	4-10
4.2	Equipment Configurations	4-11
4.2.1	Radar Target Skin Tracking	4-13
4.2.2	Radar Beacon Tracking	4-14
4.2.3	Laser Tracking	4-15
4.2.4	Theodolite Tracking	4-17
4.2.5	Photographic Camera Scaling	4-18
4.2.6	Closed Circuit TV Camera	4-20
4.2.7	RF Ranging and Triangulation	4-21
4.2.8	Special Tracking Systems	4-22
4.3	Tracking Accuracy	4-23
4.3.1	Range, Azimuth and Elevation Tracking	4-24
4.3.2	RF Ranging Systems	4-30
4.4	General Performance Considerations	4-37
5.0	WEATHER DATA SUBSYSTEM	5-1
5.1	Types of Measurements	5-1
5.2	Measuring Equipment	5-2
6.0	AIRCRAFT IDENTIFICATION AND OPERATIONAL PARAMETER RECORDING SUBSYSTEMS	6-1
6.1	Operational Parameters	6-1
6.2	Aircraft Identification	6-2
7.0	DATA PROCESSING SUBSYSTEM	7-1
7.1	Performance Requirements	7-3
7.1.1	Subsystem Input	7-4
7.1.2	Subsystem Control	7-6

TABLE OF CONTENTS - Continued

<u>Section</u>		<u>Page</u>
7.1.3	Analysis Control	7-7
7.1.4	Data Base Access and Maintenance	7-7
7.1.5	Data Synchronization and Integration	7-8
7.1.6	Flyover Data Analysis	7-9
7.1.7	Output Reports	7-9
7.2	Data Processing Configurations	7-9
7.2.1	Stand Alone Analyzer/ Minicomputer	7-10
7.2.2	Batch Processing Certification System	7-10
7.2.3	Dedicated Real Time Research System	7-13
8.0	A CERTIFICATION NOISE MEASUREMENT SYSTEM	8-1
8.1	Design Considerations	8-1
8.2	System Configuration	8-2
8.2.1	Acoustical Data Recording Subsystem	8-5
8.2.2	Weather Instrumentation	8-7
8.2.3	Tracking Subsystem	8-8
8.2.4	Data Analysis Subsystem	8-9
8.3	Data Processing Software	8-9
8.4	Summary Specifications and Costs	8-11
8.4.1	Performance Characteristics	8-12
8.4.2	Costs	8-14
9.0	A RESEARCH NOISE MEASUREMENT SYSTEM	9-1
9.1	Design Considerations	9-1
9.2	System Configuration	9-3
9.2.1	Acoustical Data Site Equipment	9-8
9.2.2	Data Transmission Equipment	9-10

TABLE OF CONTENTS - Continued

<u>Section</u>		<u>Page</u>
9.2.3	Data Storage and Analysis Equipment	9-11
9.2.4	Tracking Data Subsystem	9-13
9.2.5	Other Inputs	9-17
9.3	Data Processing for the Research System	9-19
9.3.1	Vendor Supplied Software	9-20
9.3.2	Contractor Supplied Software	9-25
9.3.3	Data Synchronization and Integration (DSI)	9-24
9.3.4	Subsystem Control (SC)	9-27
9.3.5	Flyover Data Analysis (FDA)	9-29
9.3.6	Analysis Control (AC)	9-38
9.3.7	Data Base Access and Management (DBAM)	9-38
9.3.8	Building Blocks	9-42
9.4	Summary Specifications and Costs	9-43
9.4.1	Performance Characteristics	9-43
9.4.2	Costs	9-46
10.0	SUMMARY OF RESULTS	10-1
10.1	Task A Results	10-1
10.2	Task B Results	10-3
	APPENDIX A	
	Current FAR Part 36 and Proposed Rules Changes	A-1
	APPENDIX B	
	Tracking Accuracy Calculations	B-1

LIST OF ILLUSTRATIONS

<u>Figure No.</u>		<u>Page</u>
2.1	GENERAL BLOCK DIAGRAM FOR AN AIRCRAFT NOISE CERTIFICATION AND RESEARCH SYSTEM	2-2
2.2	FAR PART 36 MEASUREMENT LOCATIONS	2-8
3.1	PORTABLE TAPE RECORDER ACOUSTICAL DATA SUBSYSTEM BLOCK DIAGRAM	3-5
3.2	MULTI-TRACK RECORDER ACOUSTICAL DATA SUBSYSTEM BLOCK DIAGRAM	3-9
	REAL TIME REMOTE ANALYZER ACOUSTICAL DATA SUBSYSTEM	3-13
3.4	COMPRESSED AUDIO ACOUSTICAL DATA SUBSYSTEM BLOCK DIAGRAM	3-15
3.5	DATA LINK DYNAMIC RANGE	3-19
4.1	FAR PART 36 FLIGHT PROFILES	4-4
4.2	APPROACH PROFILE CHARACTERISTICS INFLUENCING SOUND PROPAGATION	4-7
4.3	TAKEOFF PROFILE CHARACTERISTICS INFLUENCING SOUND PROPAGATION	4-8
4.4	MAXIMUM TRACKING ERROR FOR A TRACKING SYSTEM WITH RANGE ACCURACY + 30 FT. AND AN ANGULAR ACCURACY OF + 1.0 MIL. FOR A NOMINAL 3 DEGREE GLIDE SLOPE ANGLE	4-25
4.5	MAXIMUM TRACKING ERROR FOR A TRACKING SYSTEM WITH RANGE ACCURACY + 10 FT. AND AN ANGULAR ACCURACY OF + 1.0 MIL. FOR A NOMINAL 3 DEGREE GLIDE SLOPE ANGLE	4-26
4.6	MAXIMUM TRACKING ERROR FOR A TRACKING SYSTEM WITH RANGE ACCURACY + 15 FT. AND AN ANGULAR ACCURACY OF + 0.1 MIL. FOR A NOMINAL 3 DEGREE GLIDE SLOPE ANGLE	4-27

LIST OF ILLUSTRATIONS - Continued

<u>Figure No.</u>		<u>Page</u>
4.7	MAXIMUM TRACKING ERROR FOR TRACKING SYSTEM WITH RANGE ACCURACY + 30 FT. AND AN ANGULAR ACCURACY OF + 1.0 MIL. FOR A NOMINAL 3 DEGREE GLIDE SLOPE ANGLE AND 5K FT. SIDELINE DISPLACEMENT OF TRACKING SYSTEM	4-29
4.8	MAXIMUM TRACKING ERROR FOR A TRACKING SYSTEM AT LIFT OFF WITH RANGE ACCURACY + 30 FT. AND ANGULAR ACCURACY + 1.0 MIL. FOR A TAKEOFF WITH CONSTANT CLIMB TO 1000 FT. AT 8000 FT. FROM LIFT OFF THEN 4% CLIMB	4-31
4.9	MAXIMUM TRACKING ERROR FOR A TRACKING SYSTEM AT START OF ROLL WITH RANGE ACCURACY + 30 FT. AND ANGULAR ACCURACY + 1.0 MIL. FOR A TAKEOFF WITH CONSTANT CLIMB TO 1000 FT. AT 8000 FT. FROM LIFT OFF THEN 4% CLIMB	4-32
4.10	GEOMETRY FOR TWO DIMENSIONAL RF RANGING POSITION LOCATING SYSTEM	4-34
4.11	DIFFERENTIAL RANGE ERROR FOR A TWO DIMENSIONAL RF RANGING SYSTEM	4-35
7.1	GENERALIZED INFORMATION FLOW DIAGRAM FOR AIRCRAFT NOISE MEASUREMENT DATA PROCESSING	7-2
7.2	TYPICAL STAND ALONE NOISE MEASUREMENT SYSTEM	7-11
7.3	CERTIFICATION SYSTEM IMPLEMENTED ON A LARGE SCALE BATCH PROCESSOR	7-12
7.4	DEDICATED REAL TIME RESEARCH SYSTEM	7-14
8.1	CERTIFICATION NOISE MEASUREMENT SYSTEM BLOCK DIAGRAM	8-3
8.2	ACOUSTICAL DATA SUBSYSTEM BLOCK DIAGRAM	8-6

LIST OF ILLUSTRATIONS - Continued

<u>Figure No.</u>		<u>Page</u>
9.1	RESEARCH SYSTEM BLOCK DIAGRAM	9-5
9.2	VENDOR AND CONTRACTOR SUPPLIED COMPONENTS OF THE AIRCRAFT NOISE RESEARCH SYSTEM	9-21
9.3	DSI INPUT AND OUTPUT OF ACOUSTICAL AND WEATHER DATA	9-26
9.4	INFORMATION FLOW BETWEEN SPECIAL PERIPHERAL DEVICES, DSI, SC, AND THE NOISE ANALYSIS SYSTEM	9-30
9.5	SIMPLIFIED MEMORY PARTITIONING FOR TWO USER TASKS	9-31
9.6	TIME HISTORY OF A NOISE EVENT	9-33
9.7	MONITOR TASK INFORMATION FLOW	9-35
9.8	EVENT PROCESSOR TASK INFORMATION FLOW	9-37
9.9	DAILY REPORT TASK INFORMATION FLOW	9-39
9.10	ANALYSIS CONTROL INFORMATION FLOW	9-40
9.11	DATA BASE ACCESS AND MANAGEMENT INFORMATION FLOW	9-41
B.1	TWO DIMENSIONAL TRACKING GEOMETRY FOR POSITION ERROR CALCULATIONS	B-2
B.2	TRACKING GEOMETRY FOR SLANT RANGE ERROR CALCULATIONS	B-4

LIST OF TABLES

<u>Table No.</u>		<u>Page</u>
3.1	EQUIPMENT SPECIFICATIONS FOR PORTABLE ACOUSTICAL DATA SYSTEM	3-7
3.2	EQUIPMENT FOR ACOUSTICAL DATA SUBSYSTEM AND DATA LINK	3-21
3.3	ACOUSTICAL DATA SUBSYSTEMS	3-26
4.1	TRACKING TECHNIQUES AND SYSTEMS	4-12
8.1	EQUIPMENT FOR ACOUSTICAL DATA SUBSYSTEM	8-8
8.2	TRACKING SUBSYSTEM SPECIFICATIONS	8-10
8.3	CERTIFICATION SYSTEM COSTS FOR SYSTEM WITH 8 SETS OF ACOUSTICAL DATA COLLECTION EQUIPMENT	8-15
8.4	TYPICAL CERTIFICATION SYSTEM EQUIPMENT COSTS	8-16
9.1	RESEARCH SYSTEM DATA PROCESSING SPECIFICATIONS	9-14
9.2	PERIPHERAL HARDWARE FUNCTIONS UNDER SOFTWARE CONTROL	9-28
9.3	RESEARCH SYSTEM COSTS FOR SYSTEM WITH SIXTEEN MONITOR SITES	9-47
9.4	TYPICAL RESEARCH SYSTEM EQUIPMENT COSTS	9-48

LIST OF ABBREVIATIONS

ANSI	American National Standards Institute
ARP	Aerospace Recommended Practice
ARTS III	Automated Radar Terminal System III
ASCII	American Standard Code for Information Interchange
ATC	Air Traffic Control
BCD	binary coded decimal
BPI	bits per inch
BW	bandwidth
cps	characters per second
CRT	cathode ray tube
dB	decibel
dba	decibel; A denotes use of A-weighting (ANSI S1.4-1971)
dBm	decibel; referred to 1 milliwatt
EPNdB	Effective Perceived Noise Level in decibel
EPNL	Effective Perceived Noise Level
F	Fahrenheit
FAA	Federal Aviation Administration
FAR	Federal Aviation Regulation
FM	frequency modulation
FSK	frequency shift keying
GHz	1000 megahertz
Hg	mercury
HNL	Hourly Noise Level
Hz	hertz (frequency in cycles/second)

LIST OF ABBREVIATIONS - Continued

ICAO	International Civil Aviation Organization
IEC	International Electrotechnical Commission
IF	intermediate frequency
ips	inches per second
IRIG-B	Interrange Instrumentation Group
ISO	International Organization for Standardization
K	1000 times (dollars)
Ku	frequency band from 12.4 to 18 gigahertz
L _{dn}	Day-Night Equivalent Level
LPM	lines per minute
mA	milliamperes
MHz	million Hertz
mil	angular measure - $\frac{1}{6400}$ of 360 degrees
mm	millimeter
mph	miles per hour
mrad	milliradian - $\frac{1}{1000}$ of 1 radian
ms	millisecond - $\frac{1}{1000}$ of 1 second
NEF	Noise Exposure Forecast
NL	Noise Level (dB)
nm	nautical mile
PNL	Perceived Noise Level
PNLT	Tone Corrected Perceived Noise Level
PNLTM	Maximum Tone Corrected Perceived Noise Level
RC	resistor capacitor

LIST OF ABBREVIATIONS - Continued

RF	radio frequency
RMS	remote monitor station
rms	root-mean-square
RTA	Real Time Analyzer
SEL	Single Event Level
SENEL	Single Event Noise Exposure Level
SENT	Single Event Noise Threshold
TV	television
T _{xx}	time above threshold xx
UHF	ultra high frequency
V	volt
VHF	very high frequency
VSWR	voltage standing wave ratio
μ V	microvolt

1.0 INTRODUCTION

Tracor, Inc., performed a study of aircraft noise measuring systems for the Federal Aviation Administration (FAA) under contract DOT-FA74WA-3539. The study was divided into two phases:

- A. an evaluation of the ten most complete and comprehensive aircraft noise measurement systems in use today in the Free World
- B. a preliminary design study, the results of which will allow the design of an advanced aircraft noise measurement and certification system.

The results of this study are presented in two documents corresponding to Tasks A and B, respectively. This is the report of the results of Task B.

This Task B report was revised, under contract DOT-FATQWA-3900, from the original draft to provide separate illustrative design examples for a research noise measurement system and for an aircraft noise certification system. The original system design was constrained by the requirements to serve both as a research and certification system, to function for both purposes in all weather conditions, and to be modularly expandable. Removal of these and other constraints allowed the design examples to be optimized separately for the certification and research functions.

For the purpose of this report an aircraft noise certification system is a system capable of precise measurement and evaluation of single aircraft flyovers for the purpose of

determining compliance with Federal Aviation Regulations (FAR) Part 36 or International Civil Aviation Organization (ICAO) Annex 16 noise certification requirements. Such certification procedures require an accurate knowledge of aircraft position and detailed analysis of acoustical flyover signatures. A detailed spectral and temporal history of each flyover must be produced, normally in tape-recorded form.

The aircraft noise research system is considered to be a system for measuring aircraft noise at several locations simultaneously in real time in the vicinity of a normally operating airport. In some ways, the research system is similar to the airport noise monitoring systems described in the Task A report. However, it has expanded capabilities and versatility to support varied research objectives. The objectives may range from measuring the differences in single event noise due to changes in flight profile of a certain aircraft type to studying the long term effect of weather on cumulative noise measures.

This report illustrates the range of performance that may be achieved in research and certification systems. Some sections are approached from a basic point of view and may be superfluous for the reader familiar with the measurement of aircraft noise. The detailed design of a certification or research system is not presented, since specific measurement objectives and operational features must be established before such a design is developed. Two design examples are included, however, to illustrate how operational features such as portability, etc., affect subsystem choices in a complete system design.

The range of instrumentation hardware and software available for either system is considered in detail. The basic subsystems required for the certification system and the research system are similar. The required accuracy, data volume, and

operating manpower, however, as well as other operational factors, will be different for the subsystems of the certification and the research system. The basic subsystems are:

1. acoustical data collection subsystem
2. positional tracking subsystem
3. weather data collection subsystem
4. aircraft performance data subsystem
5. data processing subsystem (including software)

It would be possible to configure a research system without all the basic subsystems, however, a certification system requires all the subsystems. The separate chapters for the respective subsystems show several different ways to accomplish the particular tasks. The relative merits of the various techniques are described with respect to salient engineering features such as accuracy, portability, manpower, cost, etc.

Finally, specific design objectives for a research system and for a certification system are hypothesized separately and illustrative designs for each are presented, using the subsystem components previously discussed.

2.0 GENERAL DESIGN CONSIDERATIONS

This section presents some general design considerations that influence the ultimate choice of system configuration. Such factors as research objectives, standards, FAR Part 36 requirements, operational features, data reduction, operating environment, and cost are discussed. Any one of these variables can have a great affect on the choice of a system configuration and can even dictate specific hardware. As usual, cost-performance tradeoffs must eventually be considered.

It is emphasized that this design study was to determine those design concepts with which a selectable level of performance could be achieved. Thus, this study is not an engineering design effort, but rather provides a foundation for such an effort.

2.1 Basic System Requirements

The basic subsystems required for noise certification and research systems are the same and are shown in the block diagram of Figure 2.1. The exact implementation of the elements of the block diagram will be influenced by both technical and operational requirements. A brief description of the system shown in Figure 2.1 will aid in defining system requirements and design constraints. Included are the various data collection subsystems, the data transmission medium, and the data processing subsystem. Each of the data collection subsystems is time synchronized in some fashion. Some preliminary data processing can be done by the data collection subsystems before transmission to a central site for final processing and analysis. Transmission can be in real time via wire or radio link, or delayed in time via magnetic and/or paper tape storage. The data processing subsystem can control real time operation of the system or it can be used for post-flight

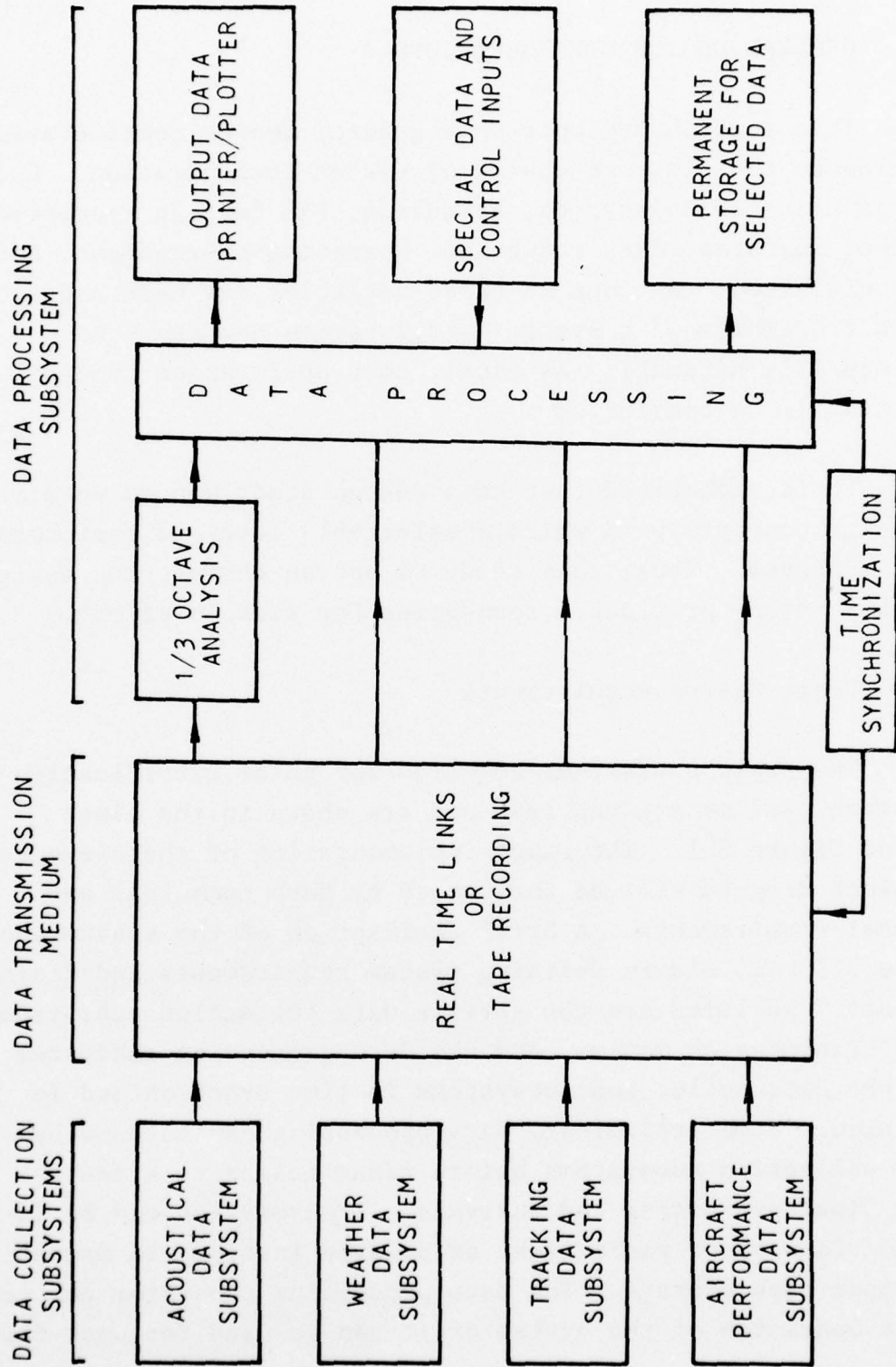

FIGURE 2.1 GENERAL BLOCK DIAGRAM FOR AN AIRCRAFT NOISE CERTIFICATION AND RESEARCH SYSTEM

analysis of recorded data. In both types of operation, the data processing system must apply corrections and combine the data for final processing. Data processing and analysis requirements in all systems considered here are of such complexity that a digital computer is almost indispensable as an integral part of the data processing subsystem.

The acoustical, weather, and tracking subsystems may all be located at separate geographical locations, although all will be within a few miles of the airport. The aircraft performance subsystem will be on the test aircraft. This diversity in locations presents data transmission and logistical problems that are important system design considerations.

Two considerations that affect the system design in several ways are the test site (airport) and data volume.

- (a) Test site - The system requirement for portability of all or part of the equipment may be imposed or a permanent installation at a particular airport may be indicated. Once the airport is selected, access to the acoustical monitoring sites may be limited by roads and other man-made and natural obstacles. Each airport presents unique requirements of access for both acoustical and tracking systems which will impact the system design. The choice of the airport may be made so that existing tracking and data telemetry or other facilities can be utilized for economy.

- (b) Data volume - The quantity of data to be collected will impact the system design. This is in turn dependent on the research objective or, in the case of certification measurements, the number of

certifications to be made. The tradeoff between manpower and cost of automatic equipment depends mainly on the data volume.

2.2 Certification Noise Measurement System Considerations

The specific measurement objectives which must be met for noise certification tests are given in FAR Part 36 (Appendix A) and the specific items that have major impact on measurement system design are summarized in this section.

2.2.1 General Design Considerations

Certification tests are conducted by the aircraft manufacturers and are observed and monitored by the FAA. The equipment is provided by the aircraft manufacturer either from his own inventory or through consulting or lease agreements. Tests are required only once for a particular aircraft configuration and typically require a few days for data acquisition. Therefore official aircraft certifications during any one year in the United States are few; however, aircraft manufacturers conduct similar tests repeatedly for engineering evaluation purposes. The data volume requirement for any system thus depends greatly on the number of design tests to be conducted.

2.2.2 FAR Part 36 Requirements

The requirements for aircraft noise certification dictate two major refinements in the capabilities of aircraft noise monitoring systems of the type studied under Task A. First, detailed spectral analysis of flyover signatures is necessary, and second, accurate knowledge of aircraft position is required. FAR Part 36 contains specific requirements for the collection and analysis of acoustical, weather, tracking, and aircraft

performance data. Aircraft noise certification requires the aircraft to be operated specifically for the associated tests. Thus, the aircraft is an active element in the tests and may be specially instrumented for this reason.

Specific data collection subsystems are given in Figure 2.1, and a summary of their respective FAR Part 36 requirements¹ are presented below:

1. Acoustical data collection

- a. sufficient data for one-third octave band analysis in the standard 24 bands (50 Hz to 10 kHz inclusive), sampled each half second.

Note: Revision of Part 36 requires data collection at least between 10 dB down points. Also, a pressure sensitive condenser microphone is specified and more stringent directivity specifications essentially require a microphone no larger than 1/2 inch in diameter.

- b. three measurement locations: two for departures and one for arrivals. Data from only one departure sideline measuring site are used; however, at least four simultaneous sideline measuring sites are required to determine the point of maximum sideline noise.

¹For subsonic transport category and turbojet powered aircraft. Appendix F of FAR Part 36 specified reduced requirements for tests of propeller driven aircraft. A revision of FAR Part 36 is currently being considered, as published in the Federal Register Thursday, October 28, 1976 and attached as part of Appendix A of this report. The changes that have major impact on the system design are noted in the text.

2. Weather data collection

- a. at a central location, reported each hour: temperature, relative humidity, atmospheric pressure, and maximum, minimum and average wind speed and associated directions.
- b. near each microphone, reported each hour: wind velocity and temperature.
- c. temperature and humidity measurements from ground to aircraft test flight path to determine if temperature inversion or anomalous wind conditions exist.

Note: The proposed revision to FAR Part 36 requires measurement of the temperature and relative humidity from 10 meters above the acoustical measuring site to the altitude of the aircraft. Time interval between measurements must not exceed 45 minutes. The sound propagation data may be corrected using a layered model of the atmosphere with increments no greater than 100 feet.

3. Tracking data collection

- a. projected ground track and altitude within up to 6 nautical miles from the runway threshold.

Note: The proposed revision to FAR Part 36 deletes the 6 nautical mile requirement and requires sufficient data to determine the corrections for the approach angle, speed, and flight profile.

- b. sufficient data to allow calculation of the slant range to the aircraft from each acoustical

measurement location for the time of occurrence of maximum noise at the measurement location.

Note: The proposed revision to FAR Part 36 requires that the position of the aircraft be recorded for the entire interval during which the measured aircraft noise is within 10 dB of the PNLTM for each measurement location.

- c. sufficient data to allow calculation of the point of closest approach of the aircraft to each acoustical measurement location.

4. Aircraft performance data collection

- a. weight
- b. airspeed
- c. engine performance

Note: The proposed revision to FAR Part 36 requires that these data be automatically recorded at an approved rate.

Noise certification measurement positions required by FAR Part 36 impact the system design and are illustrated in Figure 2.2. These locations are summarized below:

- a. For arrivals, 1 nm out runway centerline measured from the threshold point.
- b. For departures, 3.5 nm out runway centerline measured from the brake release point.
- c. For departures, sideline measurements to determine the point of maximum noise along a line parallel to the runway displaced 0.35 nm (0.25 nm for aircraft with less than four engines).

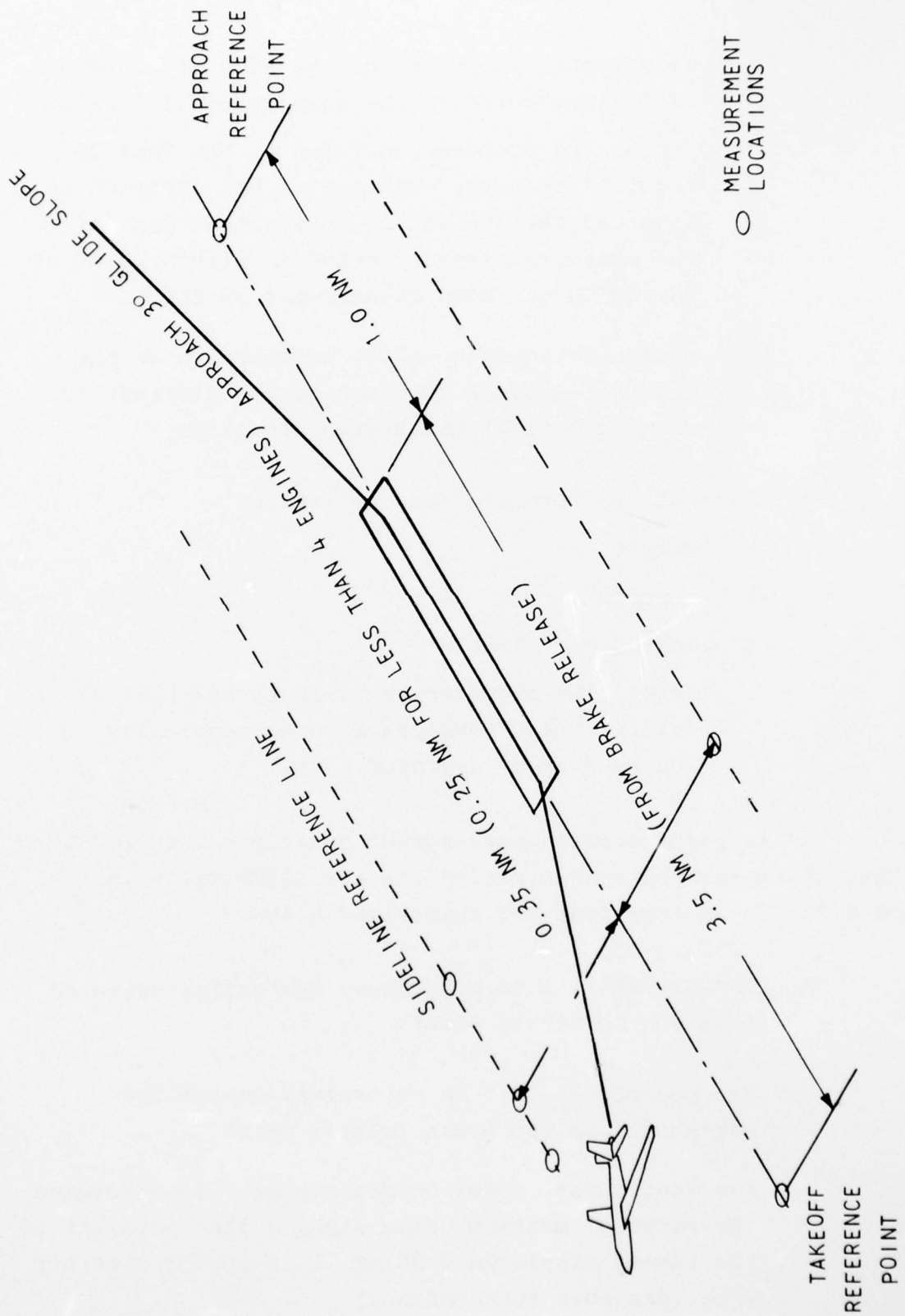

FIGURE 2.2 FAR PART 36 MEASUREMENT LOCATIONS

For FAR certification tests, specific flight paths, operating procedures, and weight limits are established in advance. During the tests acoustical, weather, tracking, and performance data are gathered. Data processing requires one-third octave band analysis of the acoustical data sampled every 0.5 seconds, correction of the acoustical data for variations in weather and aircraft position, and an analysis of the duration of the noise above a specified threshold. A single number rating (EPNL) of the aircraft noise at each location is then generated, normalized to standard conditions. This rating is then examined for compliance with FAR requirements and a judgement is made regarding certification.

2.3 Research System

The aircraft noise research system should have the versatility to handle a wide range of experiments. This should include the measurement of aircraft operating under normal flight procedures at a busy airport, as well as aircraft operated specifically for noise tests. However, research studies of aircraft noise at a busy airport typically result in handling of large volumes of data collected over extended periods of time. The research system can be used to improve measurement techniques, verify human response models, assist in noise abatement planning, verify the effect of abatement procedures, establish noise limits, etc. Specific research system functions are suggested below and the effect of these functions on the system design is considered.

2.3.1 Typical Research Applications

The following list of research applications represents some of the current questions that, when answered, would assist in understanding and controlling the noise from aircraft. Typical research applications might include:

- a. Atmospheric effects on sound attenuation
- b. Effects of ground surface variations near the measurement site
- c. Excess attenuation as a function of angle of incidence as this affects prediction of sideline noise
- d. Comparison of data taken according to FAR Part 36 with data taken using other standards and techniques
- e. Noise reduction due to flight path modifications such as two-segment approaches
- f. Differences in measurements made with different equipment meeting the requirements of FAR Part 36 (different averaging techniques, etc.)
- g. Correction techniques for high background noise areas, particularly at sideline points where atmospheric attenuation of high frequencies is great
- h. Validation of basic NEF/ L_{dn} noise model
- i. Determination of "intrusiveness"
- j. Correlation of daily variations in noise exposure with weather parameters
- k. Development of fleet noise contributions at specific location microphones
- l. Control and evaluation of preferential runway techniques.
- m. Monitoring of noise abatement procedures to insure compliance
- n. Statistical comparison of noise measures such as SENEL and EPNL

2.3.2 Operational System Design Considerations for a Research System

Each research objective listed above presents unique requirements for the research system hardware and software. Most of the objectives require the collection of data over an extended time period; therefore, automatic real time data collection is indicated. In order to collect long-term data, the equipment must function in all types of weather. Flexibility is another very important consideration in choosing subsystem components for a research system.

Generally, noise measurements are required continuously at several locations. Some research objectives can be accomplished with A-weighted sound level measurements and others require one-third octave band level data. Most currently used noise measures may be computed from one-third octave band data sampled every 0.5 seconds. To accommodate all the various computed measures such as L_{dn} , T_{xx} , EPNL, etc., a computer data collection and analysis system is required. A computer-based system also provides the needed flexibility to automatically control the various equipment systems. This allows anything from single noise event statistics to the compilation of total or cumulative measures.

Some of the research objectives require that specific noise events be correlated with the type of aircraft producing the noise. This is a large task when the system is monitoring several hundred flights per day, each of which causes a noise event at several measurement sites. The most direct way of accomplishing this task is very manpower intensive, as it requires visual observation of the flight and manual coordination of a computer entry identifying the aircraft type, etc., with the noise event. When there are limited numbers of flights, the events may be recorded with a time code and later correlated with a log of

operations or an audio recording of the tower radio. Full automation of the identification process is theoretically possible using data from the ARTS III system, which may be either hard wired or taped inputs to the noise system. However, access to these data may be limited because of air safety considerations.

The flight track followed by the aircraft must be known accurately for some experimental studies. The acceptable tracking techniques, depending on the specific equipment, can vary from an observer recording whether the flight went to his right or left to an independent skin-tracking radar. Numerous tracking systems are discussed in detail in Section 4.0; each type is best suited for particular experiments.

The requirement for weather information is also dependent on the specific experiment. When required, weather information may vary from a single site measurement of temperature and humidity to a detailed profile of temperature and humidity from ground level to the aircraft flight path.

The choice of experiments has been shown to greatly affect the system requirements. Before designing a specific system the primary experimental objective should be defined along with secondary goals. Then a detailed system can be planned that will be appropriate to the objective. Subsystems that are appropriate for such systems are discussed in detail in following sections and in Section 9.0 some typical goals are established and a research system design evaluated in terms of these goals. In system design, the following performance criteria are used to compare the various subsystems.

- a. Degree of automation
- b. All weather capability
- c. Real time data and time required for data output

- d. Portability and ease of setup
- e. Modular expansion capability
- f. Accuracy
- g. Costs
- h. Versatility – easily configured for different measurement and analysis tasks
- i. Manpower requirements and support requirements
- j. Permanent record of data
- k. Standards

2.3.3 Applicable Standards

Various national and international standardization organizations have issued standards and recommended practices which are related to aircraft noise measurement. Those which are incorporated in FAR Part 36 by reference are listed below:

- a. International Electrotechnical Commission, Publication 179, Precision Sound Level Meters, 1965.
- b. International Organization for Standardization (IEC) 225, Octave, Half-octave and Third-octave Bandpass Filters Intended for the Analysis of Sounds and Vibrations.
- c. Society of Automotive Engineers, Inc., Aerospace Recommended Practice (ARP) 866A, Standard Values of Atmospheric Absorption as a Function of Temperature and Humidity, Revised March 15, 1975.

For general research and certification purposes it is desirable to have a measurement subsystem which is capable of being adapted

to comply with other widely used standards. It is also desirable to incorporate the requirements of certain standards into the FAR Part 36 measurement technique when the standards are applicable and can clarify techniques not specifically addressed therein. Standards considered for these purposes are listed below:

- a. International Civil Aviation Organization (ICAO), Aircraft Noise, Annex 16 to the Convention on International Civil Aviation, 1971.
- b. International Organization for Standardization (ISO), R.507-1970, Procedure for Describing Noise Around an Airport.
- c. International Electrotechnical Commission, 29C: Electro-Acoustical Performance Requirements for Aircraft Noise Certification Measurements, July 1974.
- d. International Organization for Standardization, R 1716-1970, Monitoring Aircraft Noise Around an Airport.
- e. International Organization for Standardization, Redraft R1760, Procedure for Describing Aircraft Noise Around an Airport.
- f. Society of Automotive Engineers, Inc., Preliminary Draft of Aerospace Recommended Practice 796, Measurements of Aircraft Flyover Noise, Revised April 24, 1974.
- g. Society of Automotive Engineers, Inc., Proposed Aerospace Recommended Practice 1264, Airplane Flyover Noise Analysis Systems used for Effective Perceived Noise Level Computations, January 11, 1973.

- h. American National Standards Institute, Inc. (ANSI),
ANSI S1.4-1971, Specification for Sound Level
Meters.

- i. American National Standards Institute, Inc., ANSI
S1.11-1966, Octave, Half-octave and One-third Octave
Filter Sets.

3.0 ACOUSTICAL DATA SUBSYSTEMS

The acoustical data subsystem receives the noise at several remote locations, analyzes the data in one-third octave frequency bands, conveys the data to a central location, and records the results of the frequency analysis. The order of these steps may be changed and interim processing and recording steps may be inserted to meet specific operational requirements. The recording is synchronized in time to allow coordination with data from other subsystems.

3.1 Performance Requirements

For this report, only acoustical data subsystems that are capable of performing one-third octave band frequency analysis are considered. This capability is a requirement for certification measurements and appropriate for a versatile research system. Systems that use only a single weighted measure (such as dBA) for the acoustical data require much simpler hardware appropriate for noise monitoring systems. Monitoring systems are described in a companion report, Airport Noise Monitoring Systems, Task A Final Report, FAA-RD-75-216.

3.1.1 Certification System

The electrical and acoustical specifications required for a certification noise measurement system are described in Appendix A, Section A36.3 of FAR Part 36, and the referenced international standard IEC 179 (dated 1973) and IEC 225 (dated 1966). FAR Part 36 is attached as Appendix A. The detailed performance specifications of FAR 36 will not be repeated here; however, some of the general requirements that influence system design are listed below.

1. Simultaneous acoustical measurements must be made at four side line locations (2 on each side of the runway)

and a perpendicular distance of 0.35 nm from the centerline extension) and one centerline location 3.5 nm from brake release.

2. The sound produced by the aircraft must be recorded in such a way that the complete information, including the time history, is retained.
3. Data must be recorded with a time code or other time synchronization for coordination with the outputs from other subsystems.
4. Data analysis - One-third octave band levels in 24 contiguous bands starting at 50 Hz must be recorded every 1/2 second.
5. Microphone - The microphone specifications essentially require a 1/2 inch (or smaller) condenser type microphone.
6. Single-frequency acoustical calibration and broadband electrical calibration sources must be provided for field use. Pure-tone normal incidence pressure calibration of the microphone and preamplifier at each one-third octave band center frequency must be performed within 30 days prior to certification tests.
7. Microphone windscreens are required for wind speeds greater than 6 knots.

3.1.2 Research System

Many of the research objectives listed in Section 2.0 require the collection and analysis of the acoustical data in one-third octave bands, as required for the certification system. Therefore the collection of one-third octave noise data with equipment meeting the requirement of FAR Part 36 Section A36.3 is considered

minimum performance for the research system. The electrical and acoustical equipment tolerances described in A36.3 are also applicable to the research system.

The research system should maintain maximum flexibility so that the widest possible range of experiments can be conducted. By collecting the acoustical data in 0.5 second samples of the one-third octave band levels the majority of the detail is retained. The data processing system can be programmed to utilize the portion of the data necessary at any given time for the specific research problem.

Although the electrical and acoustical specifications for the research system noise measuring subsystem are almost the same as those for the certification system, there are other requirements that influence the research system design. Some of these design considerations are:

- a. There may be many measurement locations, widely separated, and possibly located in residential neighborhoods.
- b. Experiments may require collection of data for long periods of time (days, weeks, or even years). This dictates a high degree of automation and real time collection of data at a central site.
- c. A wide dynamic range of signal levels (90 dB minimum) is required. This is necessary to accommodate experiments involving both background noise and aircraft noise measurements.

3.2 Equipment Configurations

All possible equipment configurations and their general performance characteristics (such as portability, necessary operational manpower, ease of deployment, real time/delayed output, data transmission, volume of data storage, and cost) will not be considered. Attention will be given only to those systems that could be practically deployed to collect acoustical data at widely separated field locations and also provide operational or cost advantages.

3.2.1 Portable Tape Recorder Acoustical Data Subsystem

The portable tape recorder acoustical data subsystem shown in Figure 3.1 consists of portable instrumentation packages, powered by internal batteries, that are placed at each measurement site just before tests are to be conducted. The acoustical data are recorded on analog tape and hand carried to a central site for one-third octave band analysis. Data processing is inherently delayed and can be done through a single one-third octave band analyzer at any location, even in another city, depending on the time delay acceptable between recording and final data processing. The tape recorder is turned on and off by a radio link from the central site or may be manually operated. The tape recorder is turned on prior to the arrival of the aircraft over the measurement site and turned off a sufficient time after it has passed for the signal level to drop below the range of interest. The electrical calibration may be inserted before and after each fly-over or at the beginning and end of the tape or test sequence. Acoustical calibration levels are inserted at the beginning and end of the test sequence. A time code synchronization signal in a format such as IRIG-B is recorded on the tape and can be transmitted from the central site or generated by a local time code generator. The electrical calibration may also be remotely or manually controlled.

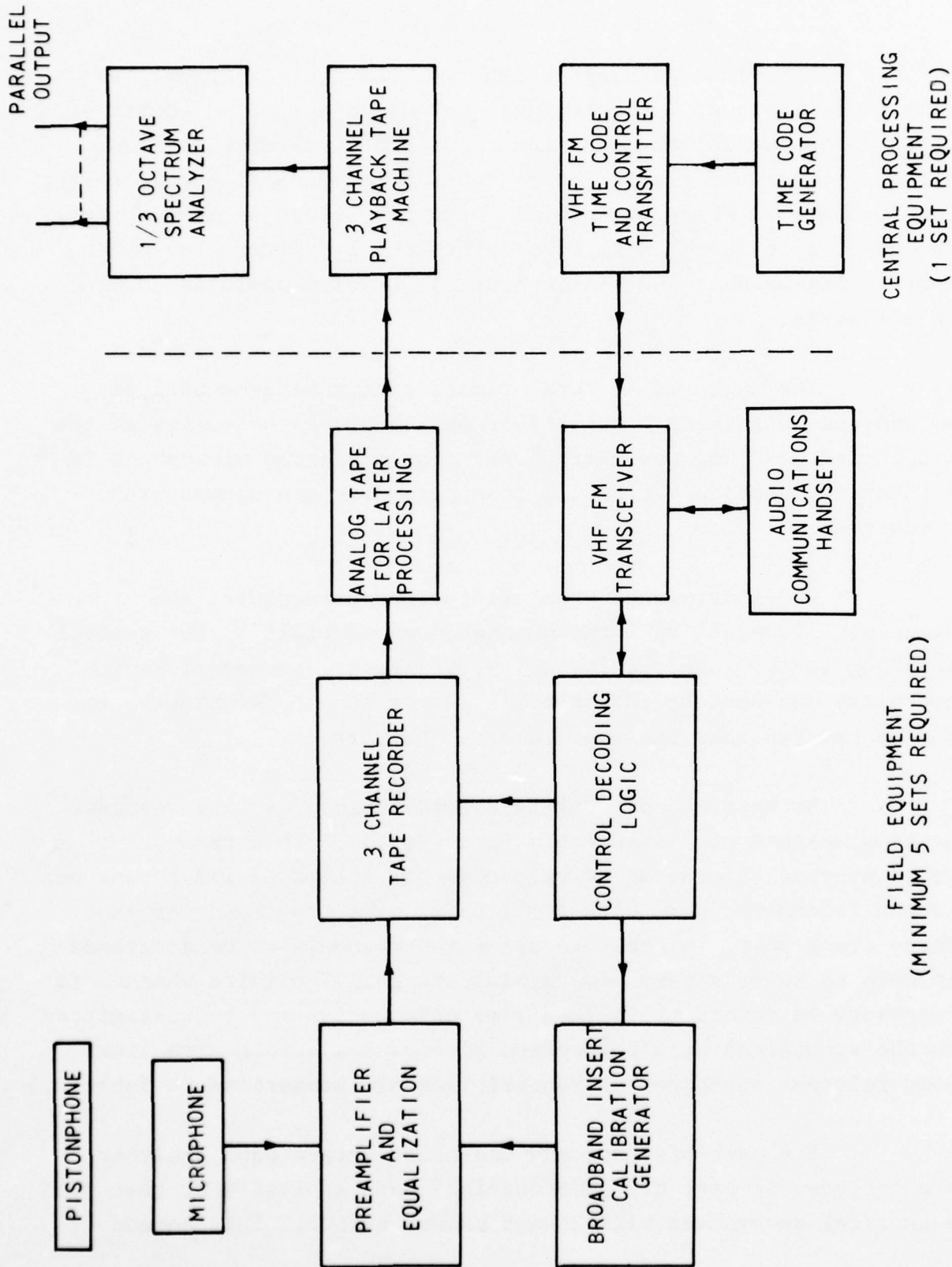

FIGURE 3.1 PORTABLE TAPE RECORDER ACOUSTICAL DATA SUBSYSTEM BLOCK DIAGRAM

The small size and weight of this system, as well as relatively low cost, make it ideal for doing a limited number of tests under controlled conditions. It can be carried from one airport to another easily, as no power or communication lines are required at the measurement site. For certification measurements, the exact site location must be determined by a survey or other appropriate means. The pistonphone calibration would be common to all sites.

The approximate total remote site equipment package volume and weight are 1 cubic foot and 25 pounds exclusive of the tripod for mounting the microphone. The preferred microphone is a standard laboratory type 1/2 inch condenser microphone with windscreen.

The microphone, preamplifier, tape recorder, and transceiver can all be items purchased commercially. The control decoding logic, insert calibration, generator, and equalization circuitry can best be custom-built, using common techniques, and can be powered from the tape recorder battery.

Because of portability considerations, a tape recorder using a maximum of 7-inch reels is suggested. This recorder would provide 48 minutes of recording per reel at 7-1/2 inches per second recording speed with 1 mil tape. The tape recorder is a three track unit, in order to allow two channels to be staggered in gain to cover a very wide dynamic range. The third channel is necessary to record the IRIG-B time code, which may be transmitted to the acoustical data collection site over a VHF FM data link. Some relevant equipment characteristics are summarized in Table 3.1.

The tape playback and one-third octave band analyzer are included as part of the acoustical data subsystem so that all acoustical subsystems will have a common output. This common

TABLE 3.1
EQUIPMENT SPECIFICATIONS FOR PORTABLE
ACOUSTICAL DATA SUBSYSTEM

Name	Relevant Specifications and Characteristics
Microphone	1/2 inch condenser per IEC 179 (tripod mount)
Preamplifier	Preemphasis of 6 dB/octave, starting at 2 kHz
Broadband Calibration Signal	Stability \pm 0.2 dB
Decoding Logic and Command	Calibration inject off/on, recorder off/on, standby for low power
FM transceiver	Receiver sensitivity, 0.35 μ V; transmitter power, 2 watts
Recorder	Record and playback response (direct) at 7½ ips, 25 Hz to 20 kHz Signal to noise ratio, 60 dB Power, 12V at 250 mA

output is one-third octave band level data sampled every 0.5 second. It is in digital format with a minimum resolution of 0.25 dB. With such a portable acoustical data subsystem, only one set of analysis equipment is required, which could operate in a laboratory environment. The playback recorder could be one of the data collection recorders. The one-third octave analyzer is common to all acoustical data subsystems and a special section (Section 3.3) is devoted to this piece of equipment.

3.2.2 Multi-Track Tape Recorder Acoustical Data Subsystem

The multi-track tape recorder acoustical data subsystem uses only one tape recorder to record the acoustical data from several microphone sites. This technique provides the advantages

of having the audio data from all the measurement sites available in real time at one central location. The central location would typically be an instrument van with a self-contained power system for the recorder and other instrumentation. Therefore monitoring and recording can be achieved reliably and with minimum manpower. A minimum of equipment (microphone and cable driver) is required at each measurement site. This technique is ideally suited to the collection of acoustical data from several closely spaced microphones and would be cost effective in this application. However when measuring sites are widely spaced, such as on opposite sides of an airport, or in communities, the practical problems of cable length and routing may preclude the use of this subsystem.

In the configuration shown in Figure 3.2 the recorded data on the analog tapes are hand carried to a data reduction laboratory for playback through the one-third octave band spectrum analyzer to provide data for the data reduction subsystem. This system can be greatly enhanced, however, by adding a spectrum analyzer and minicomputer to the recording van. This would then allow real time computation of EPNL values. The practical advantages would include the ability to examine the data quickly, so that any required re-runs or adjustments of the experimental conditions could be made immediately.

Reference calibration levels are provided by a pistonphone which is used at least at the beginning and end of each test session or of each reel of tape. Background noise and insert calibrations should be performed before and after each flyover. The insert voltage may be single frequency or broadband noise and would be activated by a separate control wire or manually if the microphones are closely spaced.

All the equipment shown in Figure 3.2 is commercially available. The microphone should be of the standard laboratory

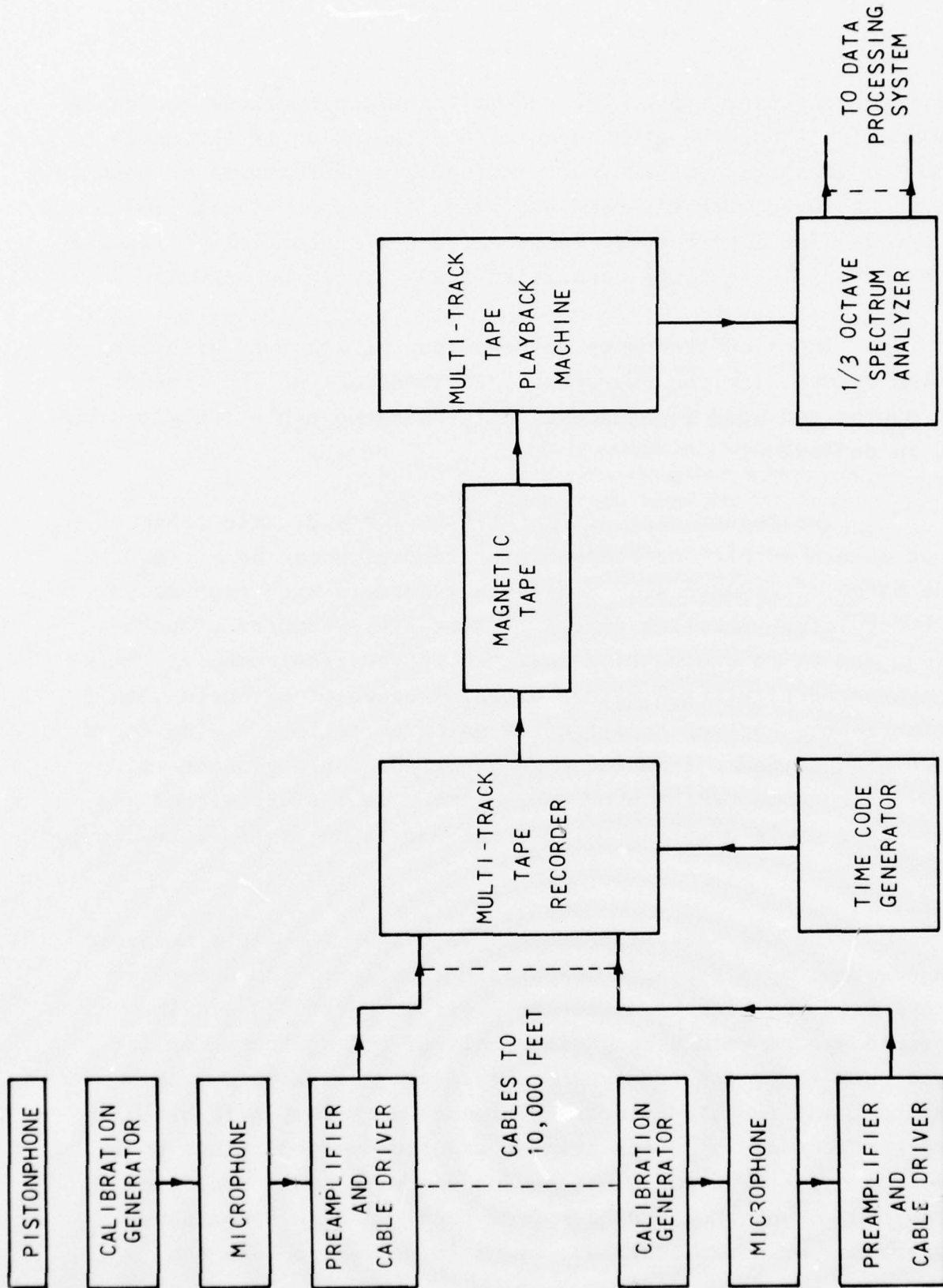

FIGURE 3.2 MULTI-TRACK RECORDER ACOUSTICAL DATA SUBSYSTEM BLOCK DIAGRAM

1/2 inch condenser type. The preamplifier/cable driver and cable combination should be given special consideration if the cable runs are greater than 500 feet. Acceptable performance to 5000 feet can be achieved with standard equipment if proper signal limits are observed. For longer runs, cable drivers with sufficient reserve power to drive the large capacitive loads should be used.

Improved frequency response can be achieved with long cables by matching the characteristic impedance of the line to the source and load impedances. Well-designed cable reels are an aid in deployment.

The requirement of FAR Part 36 for a dynamic range of 45 dB in a one-third octave band for recording can be met by a wide range of commercially available recorders with from seven to twenty-eight parallel tracks. There are recorders of both direct and FM recording type that meet these requirements. This subsystem configuration allows parallel usage of channels with a common input, but set to different gains to achieve a wide dynamic range when needed. The time code generator would produce an IRIG-B time code, which provides a time update every second and, by carrier cycle counting, allows interpolation if finer resolution is desired.

The playback recorder may be either the field recorder, for economy, or a separate compatible recorder. The one-third octave band analyzer is discussed later in Section 3.3. The expanded system with a real time analyzer and minicomputer for field data reduction requires for hardware an analyzer, minicomputer, and console printer. For such a system, a 16 bit, 32K word computer and a 30 cps printer are recommended. This could easily provide EPNL calculations for one site, with real time data input or data played back from tape. A high speed paper tape reader or other auxiliary means is needed to load the

computer program. The added computer equipment for real time data processing would at least double the cost of the acoustical data acquisition system.

3.2.3 Real Time Remote Analyzer System

The primary advantage of this system is that the acoustical data are transmitted from the microphone measuring sites to the central location over standard voice grade telephone circuits. Accuracy is insured by digital transmission of the data. This convenience is achieved at the cost of reduced information and increased complexity and cost of the remote site electronics. Telephone lines do not have adequate bandwidth, stability, or dynamic range to transmit the audio signals directly and do not have sufficient bandwidth to transmit the digitized audio waveform signals.

For this system, the information rate is reduced by analyzing the signal in one-third octave bands and transmitting all the band levels every 0.5 second to the central site. This requires that a one-third octave analyzer be placed at each remote site. Analyzers are relatively expensive and are generally designed for the laboratory rather than the harsh environments found in the field. It should be noted that a system of this type is most effectively deployed on a permanent or at least semipermanent basis.

The one-third octave band data recorded every 0.5 second meet most experimental objectives; however, no tape recorded analog data are then available for narrow band frequency analysis or averaging time experiments. The real time data availability from multiple sites allows for continuous computer controlled data collection for many experimental purposes, as described in other sections of this report.

The system operation is illustrated in the block diagram of Figure 3.3. A separate, complete set of equipment, as shown in Figure 3.3, is required for each microphone location. The microphone signal is measured simultaneously by a wide dynamic range A-weighted detector and a one-third octave band analyzer. Both the analyzer and A-weighted detector have digital outputs that sample every 0.5 second and are encoded into a single serial bit stream for transmission to the central location. The data rate can be less than 1200 baud, which can be transmitted reliably over a voice grade telephone line using conventional data transmission techniques and hardware. Therefore, a new one-third octave level for each band and a separate A-weighted level from each site are available to the data processing system every 0.5 second. The calibration inject source and the gain setting of the analyzer are under computer control from the central site over a reverse channel on the same telephone line. This allows the analyzer gain to be set manually or automatically using the A-weighted channel as a reference. Also, the data processing load of the data reduction system can be reduced by accepting only the A-weighted data until events of interest occur, as noted by increased A-weighted level.

This system can operate in an unattended mode and is best suited to long term experiments. The hardware must therefore be able to perform satisfactorily outdoors for extended periods of time. Weatherproof microphone systems, available commercially, are necessary. Special enclosures should be provided for the analyzer and other electronics to protect these from the elements. The A-weighted processor could be a separate monitor type remote unit or could be a filter channel added to the one-third octave analyzer. The one-third octave analyzer hardware could be a laboratory type analyzer properly protected or adapted for the heat and cold, or a special analyzer could be designed and constructed to meet the environmental requirements. The decoding and encoding logic are specially constructed to match the analyzer and other

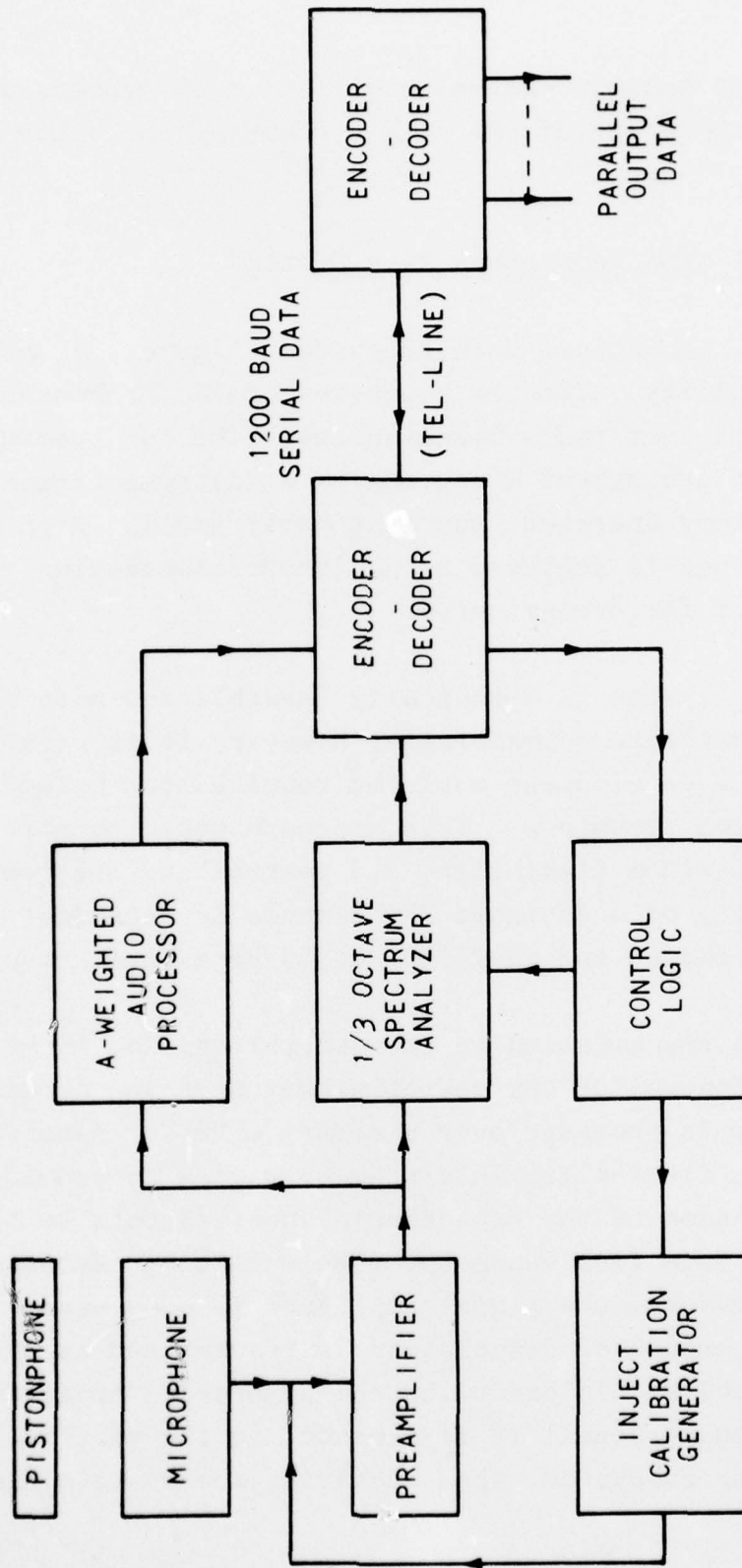

FIGURE 3.3 REAL TIME REMOTE ANALYZER ACOUSTICAL DATA SUBSYSTEM

equipment. The optimum design details of such systems will change rapidly with the state of the art in computer and other electronic hardware.

3.2.4 Real Time Compressed Data System

This acoustical data subsystem, Figure 3.4, provides maximum flexibility. The raw acoustical data (broadband signals) are transmitted over radio links in real time for recording and analysis. The acoustical measuring site instrumentation can be portable, battery operated, and reasonably small. A wide dynamic measurement range is achieved by amplitude compression of the acoustical data for transmission.

This system is technically feasible and most of the hardware is available commercially; however, it is relatively costly and some development would be required to implement the data compression technique. This approach would be most appropriate where maximum flexibility and portability are required. The availability of unassigned RF channels is dependent upon the specific site chosen and therefore could be a limitation.

Data transmission to the central station is by UHF radio link. Control of the operating modes of the acoustical data subsystem is provided over a separate VHF transceiver radio link. Maximum flexibility in system operation is provided by radio transmission of the broadband acoustical data to the central station. The data link cannot provide sufficient dynamic range directly, therefore, the signal amplitude is compressed in precision steps and the amount of compression is transmitted as a digital signal frequency-multiplexed with the compressed broadband audio signal. The audio signal is re-expanded in the central station data processing subsystem, thus achieving the 90 dB minimum dynamic range.

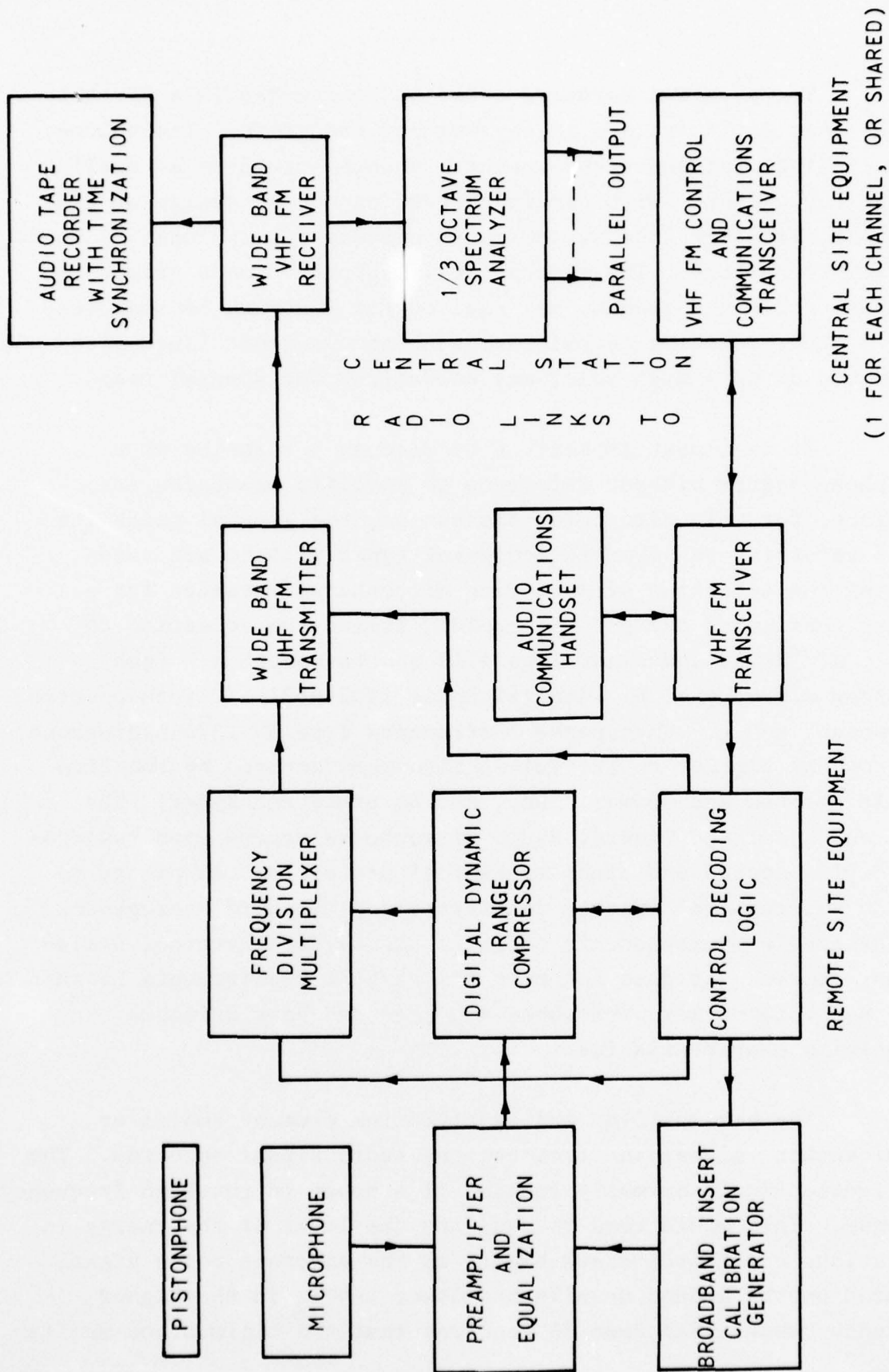

FIGURE 3.4 COMPRESSED AUDIO ACOUSTICAL DATA SUBSYSTEM BLOCK DIAGRAM

The physical hardware could be configured in a portable package that would operate in any weather condition. Its volume, not including microphone and weather sensors, could be as small as four cubic feet. With careful attention to the design of the interface circuitry, the system could operate for at least 24 hours on a single battery. The microphone is supported on a tripod four feet above the ground, as required for FAR Part 36 measurements. Other mounting techniques, such as placement flush with the ground or on a high pole, may be desired for special tests.

It is almost impossible to discuss the choice of a microphone system without reference to specific manufacturers; therefore, for this particular discussion, the general guideline of not referring to specific equipment types will be set aside. Limiting the selection of measuring microphones intended for all weather continuous outdoor use rapidly limits the selection to three: a. Brüel and Kjaer Type 4149 quartz-coated 1/2 inch condenser microphone, b. General Radio 1962-9601 1/2 inch electret microphone, and c. Chesapeake Instruments Type NM-137A hydrophone. A microphone similar to the (c) is also manufactured by the firm of Bolt Beranek and Newman, Inc., and by Brüel and Kjaer. The Brüel and Kjaer and General Radio microphones depend upon replaceable drying agents and other mechanical protection techniques to provide the required weather resistance for standard microphones. The Chesapeake microphone is of an inherently weatherproof sealed design; however, it does not meet FAR Part 36 requirements because it is not a condenser microphone and does not have suitable directivity characteristics.

The preamplifier and equalization element amplifies the microphone signal and flattens the audio signal spectrum. The equalization would normally consist of a boost in the high frequency response. This would tend to equalize the level of the energy in the various one-third octave bands, as the aircraft noise signal measured on the ground usually has lower levels in the higher frequency bands. FAR Part 36 requires that the minimum and maximum

one-third octave band levels between 800 Hz and 11,200 kHz be no more than 20 dB apart. In normal practice a single boost or preemphasis of 20 dB per decade (6 dB per octave) beginning at 2 kHz is used; however, this should be field changeable to accommodate long range conditions or other special requirements. A broadband (pink noise) electrical calibration signal is injected into the microphone line ahead of the preamplifier and equalization circuitry to allow complete system electrical calibration.

The equalized audio signal from the microphone goes to the digital dynamic range compressor, which is essentially an electrically controlled 1 dB step attenuator. The amplitude of its output signal is controlled to be within a limited range (<5 dB) for large (90 dB) changes in the input signal amplitude. The digital dynamic range compressor also provides a digital signal output representing the attenuator setting and a synchronizing signal that occurs simultaneously with its change in attenuator setting. The compressed audio signal contains all the frequency information of the original signal; a digital signal contains the range setting and synchronizing information. These data are transmitted in frequency multiplexed format using the same UHF data link transmitter. At the receiving end the original wide dynamic range signal can be reconstructed by an expander (inverse digital compressor) for analysis or recording. The internal control function of the dynamic range compressor can be selected to accommodate the desired rate of change of the input audio signal. This will determine how frequently the digital range compressor must change its setting. Change rates of 30 per second can easily be handled in hardware and should be sufficiently fast for normal acoustical signals.

The UHF data link performance must be specified before the required overall system performance can be determined. To meet the desired system performance, a wideband FM system was

chosen that could utilize the improvement in dynamic range available by using a large modulation index. A wideband system of this type would probably have to operate in the 2000 MHz range to ensure adequate electromagnetic spectrum availability. Hardware is available to meet these requirements. System performance calculations show that a 75 dB signal to noise ratio may be achieved. These calculations were based on a 6 nm line-of-sight transmission path, a data bandwidth of 15 kHz, a modulation index of 10, and an FM carrier-to-noise ratio of 40 dB. If a 30 dB fade margin is included in the calculation a signal-to-noise ratio of 45 dB will be available for the broadband data.

Figure 3.5 illustrates the dynamic range of the data link. The input signal is compressed to a level 10 dB below the maximum peak signal capability to allow instantaneous peaks which are 10 dB above the compressed level. In the worst case analysis with 30 dB fade margin, this leaves a 35 dB range below the compressed level to account for unequal one-third octave band levels. Since 20 dB is the maximum spectrum skew allowed by FAR Part 36, this 35 dB range is more than adequate. Also, in one-third octave bands the dynamic range will be greater than that indicated for the broadband 15 kHz case, since the narrower bandwidth, lower frequency bands will have a greatly improved dynamic range. The combination of digital dynamic range compressor and wideband data link thus provides for transmission of the broadband acoustical signal with a dynamic range of 90 dB and a maximum third octave spectrum skew of 35 dB.

The frequency division multiplexer has as inputs the broadband (10 Hz to 15 kHz) compressed audio, the dynamic compressor level and synchronization signal in serial digital format, and the weather data signal, also in serial digital format.

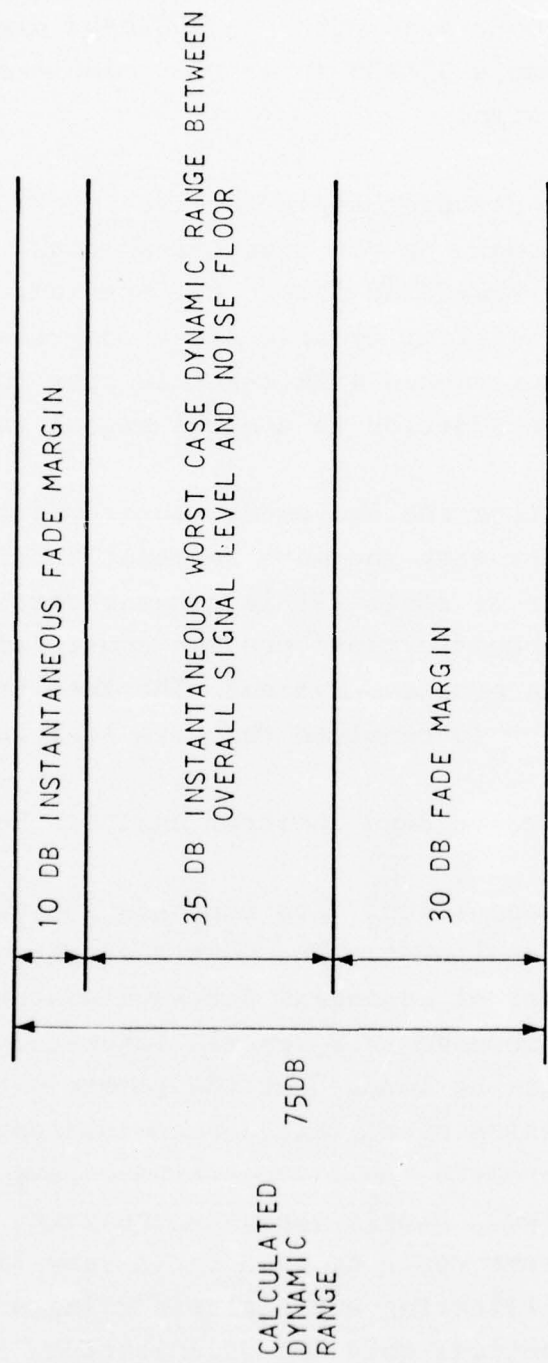

FIGURE 3.5 DATA LINK DYNAMIC RANGE

The composite output signal that modulates the wideband UHF FM transmitter is the compressed audio from 10 Hz to 15 kHz, a subcarrier at 25 kHz modulated with the 300 baud digital range compression signal, and a 35 kHz subcarrier modulated with the digital weather data signal.

The control decoding logic receives control commands from the computer through the VHF transceiver data link. Control command functions are broadband insert calibration, low power standby mode, or fix level of digital dynamic range compressor. The VHF FM transceiver is a narrowband walkie-talkie type unit and provides voice communication in addition to control signal reception.

Table 3.2 lists the equipment required for the acoustical data subsystem together with the most relevant specifications. The RF data link equipment is specified in greater detail than most of the items since its specifications are the controlling factor in the feasibility of the proposed system. The receiving end of the data link is also shown to complete the data link specification.

3.3 One-Third Octave Band Spectrum Analysis Equipment

All of the acoustical data subsystems include one-third octave band analysis equipment. The more comprehensive subsystems require one set of equipment for each measurement site. The equipment may be located in a central laboratory or, in some system designs, it must be located at the remote site to preprocess the data for transmission over limited bandwidth data channels. Only analyzers that process the 24 one-third octave bands in parallel are considered. Simple analysis equipment using tunable one-third octave filters could be used for a very limited amount of data, and digital filtering and analysis using a general purpose computer would be practical only for organizations that already have the capability and desire to process only a limited amount of aircraft noise data.

TABLE 3.2
EQUIPMENT FOR ACOUSTICAL DATA SUBSYSTEM
AND DATA LINK

Name	Relevant Specifications and Characteristics
Microphone	Frequency response per IEC 179, (0° incidence, free field), 20 Hz to 10 kHz (+1 dB, -2 dB) Dynamic range 40-140 dBA
Preamplifier	Variable high frequency boost equalization
Frequency Division Multiplexer	3 channel: 10 Hz-15 kHz analog, 25 kHz subcarrier (4 kHz BW) digital, 35 kHz subcarrier (4 kHz BW) digital
Digital Dynamic Range Compressor	Attenuator accuracy, + 0.1 dB Attenuator steps, 1 dB Maximum change rate, 30 times/second Data lost due to dead time, < 1 ms
Broadband Insert Calibration Generator	+ 0.2 dB stability
Control Decoding Logic	Detects minimum of 8 codes
VHF FM Transceiver	2 watt transmit power, receive sensitivity 0.35 V for 20 dB quieting
LHF FM Transmitter	Output frequency, 2200-2300 MHz Output power, 1 watt into 50Ω load, 1.5:1 VSWR Modulation type, true FM, positive sense Frequency response, 10 Hz to 500 kHz + 1.5 dB Carrier deviation, S band, + 600 kHz Power requirements, 28 ± 4 volts @ 500 milliamps Antenna, horn with 18 dB gain

TABLE 3.2 - Continued

Name	Relevant Specifications and Characteristics
UHF Receiver located with data processing subsystem	Frequency range, 2200-2300 MHz Noise figure, 12 dB maximum Image rejection, 60 dB Spurious response rejection, 60 dB Sensitivity, -82 dBm for A/N 20 dB, -102 dBm noise floor IF bandwidth, -3 dB 1 MHz, -60 dB 5 MHz Input power, 28 V @ 100 milliamps Temperature, -40°C to +70°C

3.3.1 Performance Requirements

The electrical performance requirements for the one-third octave analysis equipment are established in Appendix A of FAR Part 36, Paragraph A36.3(d). The detailed tolerance and specification will not be repeated here; however, the specification items that have a large influence on the system design are listed below:

- a. Frequency analysis is performed in 24 contiguous one-third octave band filters with center frequencies from 50 Hz to 10 kHz. The passband ripple must be less than 0.5 dB. The filter must meet specifications of IEC Publication 225. The frequency response requirement is normally met using a Chebyshev filter with 6 poles (3 resonators).
- b. The detector for each filter must operate over at least a 60 dB dynamic range and perform as a true root-mean-square (rms) device for sinusoidal tone bursts having a crest factor up to 3.
- c. The dynamic response (proposed rules) must be such that, when a 500 ms duration sinusoidal pulse is applied, the maximum output value is 4 dB (+0.5 or -1 dB) less than the value obtained for a steady state sinusoidal signal of the same frequency and amplitude.
- d. When a steady state signal is interrupted, an output value of 2.5 ± 1.0 dB below the initial steady-state response must be achieved within 500 milliseconds after the interruption.

- c. A single value of the level must be provided every 500 ± 5 milliseconds for each of the 24 one-third octave bands. The levels for all of the 24 one-third octave bands must be obtained within a 50 millisecond period. No more than 5 milliseconds of data from any 500 millisecond period may be excluded from the measurement.

There are several commercially available instruments that can perform the one-third octave band analysis. These instruments are designed for laboratory use and the cost range is about ten to twenty thousand dollars. Specific choices should consider ease of interface to other system equipment, convenience, special features such as displays, variable integration periods, etc. Most instruments use analog filters, but at least one uses special purpose hardware to implement digital filters that meet the specifications. The preferred analysis procedure per FAR Part 36 is squaring the one-third octave filter outputs, averaging or integrating, and converting linear formulation to logarithmic. The detector (squaring) and integration/averaging function is performed in analog circuitry in some instruments and digitally in others.

The FAR Part 36 specifications were written when only analog instruments were available. These analog instruments used RC averagers (leaky integrators) whose dynamic characteristics met the requirements of (c) above with the appropriate RC time constant with the average output sampled at the required 0.5 second rate. However, some new instruments use digital squaring and true integration of the squared values. If this integration is carried out for 0.5 second, at the required sampling rate the instrument will not pass the dynamic response test. This difficulty is circumvented in practice by collecting the 0.5 second samples and further processing them on the digital computer. Thus a new set of 1/2 second data points is generated by the post-averaging

process such that their values are the same (within required tolerances) as if the data had been taken with an analyzer meeting the dynamic response tests. One algorithm used for post-processing is an energy average of the current and two previous 0.5 second data samples.

The corrected samples can be made to fall closer to the center of the tolerance band by using different percentages of the energy accumulated in the last three 0.5 second samples, for example, 39 percent of the last sample, 31 percent of the next to last sample, and 30 percent of the second from last sample. These unequal percentages approximate the exponential response of the analog averager. It may be necessary to use the unequal percentages to meet the attack and decay specifications of the proposed revision to FAR Part 36, as published in Federal Register Thursday, October 28, 1976.

It should be noted that some digital analyzers also provide an exponential averaging mode.

3.4 Acoustical Data Subsystem Comparisons

The four acoustical data subsystems discussed above illustrate a wide range of performance. Each system could be enhanced and modified to meet specific design objectives. The best choice for a specific application can only be made after considering the resources on hand, the amount of data to be collected and processed, the location where the test will be conducted, etc. Salient features of the system are summarized in Table 3.3. Systems of the first three types have been constructed by various aircraft manufacturers and government organizations. The fourth system is included to represent the most comprehensive system that could be assembled to meet a wide range of objectives. In this time of rapidly developing

TABLE 3.3
ACOUSTICAL DATA SUBSYSTEMS

* Relative cost is per monitoring site with cost of portable tape used as baseline.

Type	Real Time	Data Recording	Data Transmission	Portability and Power Requirement	1/3 Octave Analyzers Locations and Number	Comments	Relative* Cost
Portable tape recorder	No	Analog	Hand carried tapes	Highly self-contained, Batteries	1 central	—	1.0, but directly proportional to number of channels
Multi-track tape	No	Analog multi-track	Hand carried tapes	Yes; must connect measurement sites to central recording site by cables; power at central site only	1 central	Quick look real time PNL one channel optional with mini-computer	1.0, per microphone when 4 microphones spaced to share 1 recorder are used
Real time remote analyzer	Yes	Digital	Digital telephone line or narrowband RF data link	Power and telephone line required at measurement sites	1 each site	Alternative RF transmission of data	2.4
Real time compressed data	Yes	Analog and/or digital	Combined digital and audio wide band RF data link	Yes	1 central minimum, plus 1 for each real time band data channel	Development engineering required	2.5

technology, the specific system configuration that meets a design goal most cost-effectively may change rapidly. Technological advances can be expected to have great impact on the cost and portability of one-third octave analyzers.

4.0 TRACKING DATA SUBSYSTEMS

The tracking data subsystem establishes the aircraft position in three dimensions as a function of time. The time/position data are synchronized with the acoustical measurements. For certification tests, the positional data are used to normalize the acoustical measurements to a set of standard conditions. For research purposes, the positional data are used to correlate the acoustical data with ground tracking, range, speed, etc., and/or to evaluate noise reduction procedures such as two segment approaches, etc. The positional data subsystem includes all the equipment required to track the aircraft and provide digital, time synchronized, positional data to the data reduction subsystem.

There is a wide range of position locating techniques that can meet the performance requirements for aircraft positional tracking. The hardware to implement some of these techniques is very costly and for others, relatively inexpensive. No single technique provides outstanding performance at a low price. Each of the several techniques discussed below has a definite optional price or performance characteristic. The optimum choice of tracking systems depends greatly on the relative importance of specific performance features and price. The wide choice available is illustrated by the many different tracking systems which have been used for this purpose in the past. A partial list is as follows:

- a. Aircraft-mounted camera with ground targets
- b. Ground-mounted fixed camera and scaling of the photograph to obtain range
- c. Laser tracker accurate to within inches

- d. Portable tripod-mounted theodolites with time synchronized motion picture cameras and triangulation for position location
- e. Radars operating at 10 GHz and 25 GHz with transponders on the aircraft
- f. Radar for range with a coaxially mounted television (TV) camera for manual azimuth and elevation
- g. Fixed theodolites with real time azimuth and elevation data and cameras for correcting the real time data by photographic analysis

Presented in this section are discussions of the basic tracking requirements for aircraft noise certification and research, various candidate tracking techniques, accuracy and resolution, and tracking subsystems comparisons.

4.1 Performance Requirements

The tracking subsystem performance requirements for a certification noise measurement system are determined by an "error" analysis of the acoustical data correction parameter when interpreted according to FAR Part 36. To perform these corrections during the time the noise event is occurring, position must be measured in three dimensions to a precision of approximately ± 6 meters as referenced to the microphone location. Operational considerations such as manpower requirements and data rate are discussed in Section 4.4. The requirements for a research system may be less stringent in accuracy; however, many research goals will require large volumes of data collected over extended periods of time.

4.1.1 Certification System

During noise certification tests, FAR Part 36 requires precision measurements of projected flight trajectories extending 4 nm from the runway threshold for landings and 6 nm from brake release on departures. The acquisition of tracking data must be synchronized in time with the recording of the acoustical data. The tracking data are then used to verify that the aircraft has followed the appropriate landing and takeoff profiles, and to correct the acoustical data to represent a set of standard trajectory and performance conditions.

To best understand the accuracy and operational characteristics required for the tracking system for FAR Part 36 measurements, it is helpful to consider how the tracking data are used to correct the acoustical data to standard conditions and standard flight profiles. Using the notation of FAR Part 36, the certification test profiles are illustrated in Figure 4.1.

For definition and discussion of the various terminology used here, the reader is referred to FAR Part 36, which is reproduced for convenience in the Appendix. Only those terms required for basic understanding and emphasis will be defined in this text. These requirements are based on the current requirements of FAR Part 36, with the currently proposed rulemaking changes noted where these make significant differences in system requirements.

Referring to Figure 4.1, required noise measurement locations are point N for landings and point K for departures, combined with additional symmetrically located sideline measurement locations for departures. For landings, the nominal 3° glide slope is required from point G to point I, where the aircraft trajectory flattens. The maximum deviation from the 3° slope for a valid certification test is $\pm 0.5^{\circ}$. Corrections may be applied to the acoustical data for deviations falling within this range. The

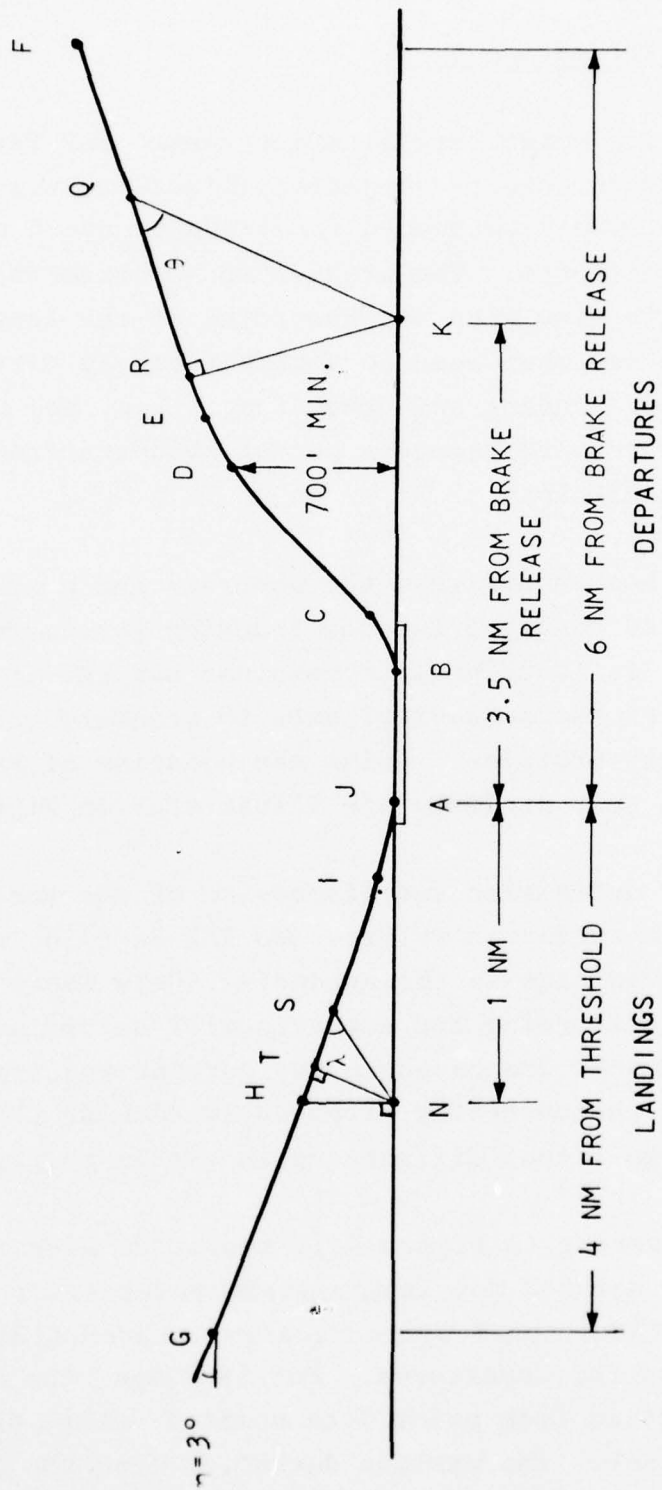

FIGURE 4.1 FAR PART 36 FLIGHT PROFILES

departure profile is different for each aircraft type, but similar flight procedures are required. Constant thrust and other control settings are required from point C to point D, and point D is required to be at least 1000 feet above the ground for 2- and 3-engine aircraft and at least 700 feet for 4-engine aircraft. At point D, the aircraft must reduce power to that required to maintain a constant climb angle of at least 4% between point E and point F, or to the power or thrust necessary to maintain level flight with one engine out, whichever power or thrust is greater.

Of the corrections which are applied to raw acoustical data taken in FAR Part 36 noise certification measurements, three require inputs from the tracking subsystem:

<u>Symbol</u>	<u>Unit</u>	<u>Meaning</u>
a. $\Delta 1$	EPNdB	PNLT Correction. The correction to be added to the EPNL calculated from measured data to account for noise level change due to differences in atmospheric absorption and noise path length between reference and test conditions.
b. $\Delta 2$	EPNdB	Noise Path Duration Correction. The correction to be added to the EPNL calculated from measured data to account for change in duration because of differences in flyover altitude between reference and test condition.

c. $\Delta 4$

EPNdB

Approach Angle Correction.
The correction to be added to the EPNL calculated from measured data to account for noise level change due to difference between 30° and the test approach angle.

During each pass of the aircraft, the maximum tone-corrected perceived noise level (PNLTM) is used in the calculation of the effective perceived noise level (EPNL) for the flyover. This value of EPNL is then corrected to represent standard conditions.

The PNLT correction ($\Delta 1$) defined above corrects the EPNL, calculated from measured data, for differences in atmospheric absorption and noise path length between reference and test conditions. The geometry describing landing profiles is illustrated in Figure 4.2. The maximum noise occurs after the test aircraft has passed over the measurement location (point N); the angle λ is typically in the range of 30 to 60 degrees. To apply the PNLT correction, the angle λ is assumed to be constant and the difference in path length between the measured path shown by the line SN and the corrected path length shown by $S_R N$ is used to correct the acoustical data. A similar procedure is used for takeoff, as shown in Figure 4.3. The corrected or reference flight paths are known in advance, therefore, the most important measurements made by the tracking system used for the PNLT correction factor ($\Delta 1$) concern the flight profile at and near the time of occurrence of maximum PNLT at the measurement locations.

The path duration correction ($\Delta 2$) uses the difference between the actual and corrected distances at the point of closest approach to the measurement site to calculate the correction to measured EPNL. For landings these distances are

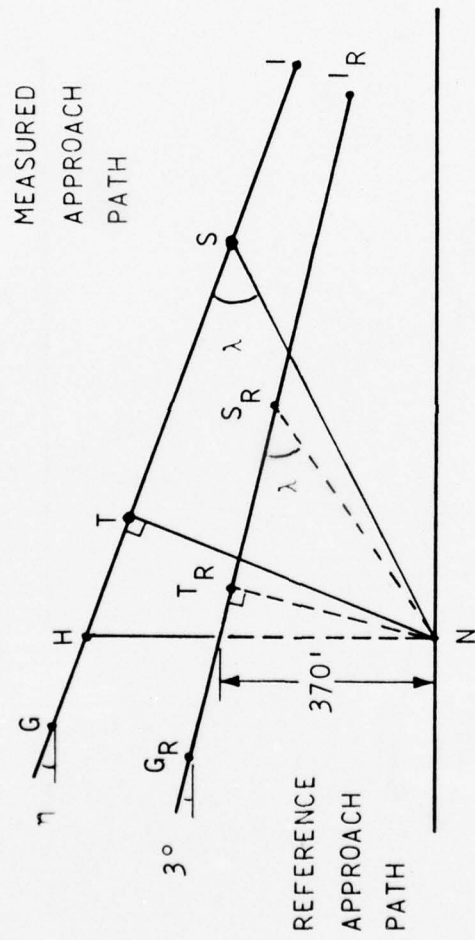

FIGURE 4.2 APPROACH PROFILE CHARACTERISTICS INFLUENCING SOUND PROPAGATION

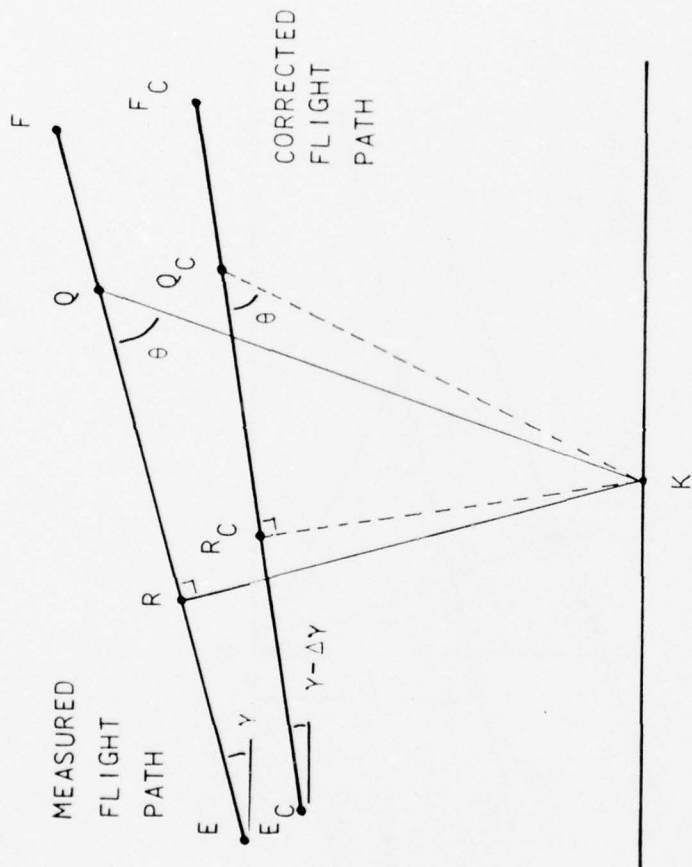

FIGURE 4.3 TAKEOFF PROFILE CHARACTERISTICS INFLUENCING SOUND PROPAGATION

shown in Figure 4.2 as TN and T_R^N . For takeoffs the distances are shown in Figure 4.3 as KR and KR_C . Note that these occur at a position almost directly over the measurement site.

The third correction to the acoustical data that requires an input from the tracking subsystem is the approach angle correction ($\Delta 4$), which is derived from the actual deviation from the specified 3° glide slope. Approved data relating the corrections and glide error must be supplied by the manufacturer of the aircraft.

The tracking requirements for FAR Part 36 noise certification measurements are summarized as follows:

1. For flight track verification: continuous height, lateral position, and position along the flight track (i.e., three dimensional position data) synchronized in time with acoustical data, from 4 nm out on landing to 6 nm from brake release on takeoff. Proposed changes in FAR Part 36 delete the specific requirement. However tracking data must be reported to establish the flight track.
2. Position information used for correcting measured acoustical data:
 - a. Distance from the measured flight track to the noise measurement points corresponding to the respective times of maximum noise at the measurement points
 - b. Distance from noise measurement points to the point of nearest approach (not required for sideline measurement points)

c. Approach angle measurement

Note: Proposed changes in FAR Part 36 specifically require precision tracking during the time interval for which the acoustic signal is 10 dB less than its maximum value.

FAR Part 36 requires that the tracking system be independent of cockpit instruments and that it be approved by the FAA. The correction of EPNL data due to flight track variation is limited to 2 EPNdB. To establish a basic range resolution requirement for the tracking subsystem, a limit of ± 0.5 EPNdB was chosen as the maximum noise level error which would accompany a certain range resolution error. To simplify calculations, the noise level tolerance and range resolution were assumed to be related only by spherical spreading. The resulting maximum tolerable range error is approximately 6% of the slant range from the measuring point to the aircraft.

The geometry and accuracy requirements of a tracking system for FAR Part 36 measurements are such that there is no single system greatly superior to others when manpower, cost, reliability, and other practical concerns are taken into consideration. During the course of this study, the basic problem of tracking within the guidelines of FAR Part 36 has been considered in detail. Many possible systems were analyzed to determine their acceptability.

4.1.2 Research System

Possible research system objectives, as defined in Section 2.0, include the study of aircraft operated in normal flight at an operational airport. The research system also permits study of noise generated by specific aircraft types operating under various flight or weather conditions, etc. Therefore no specific

requirement should be placed on the tracking subsystem until specific research goals are established. The types of research for which the various available tracking subsystems would be appropriate can be established by comparing their characteristics as described in the following discussions.

4.2 Equipment Configurations

Presented and discussed in this section are a number of tracking techniques and systems which could perform sufficiently well to be used in FAR Part 36 certification tests. Systems presented here are based upon existing hardware and require only minor equipment modification and system integration. A comprehensive list of such systems is presented in Table 4.1 with an analysis of their salient features.

In Table 4.1, two levels of performance are shown for some systems. In each such case, the better performance is accompanied by increased initial cost and decreased ease of portability.

Radar location techniques have an important advantage over any optical system in that they can provide an all-weather capability that is not limited by rain, fog, low ceiling, or other weather conditions restricting visibility. Modern radar systems are sophisticated, highly refined devices that are uniquely suited for automatic tracking of aircraft targets to a high level of precision and accuracy, particularly at long ranges. For example, high-resolution ground-based radars can provide a tracking precision of 5 meters in range and 0.1 mil (rms) in azimuth and elevation under favorable conditions.

TABLE 4.1

TRACKING TECHNIQUES AND SYSTEMS

TYPE SYSTEM	SYSTEM MEASURES	ALL WEATHER	ATTACHMENT TO AIRCRAFT	REAL TIME DATA	NUMBER OF GROUND STATIONS	PORTABILITY	AUTOMATIC/ OPERATOR CONTROLLED	DATA OUTPUT MEDIUM	BASIC MEASUREMENT ACCURACY	COMMENTS	COSTS
<u>Radio (X-Band)</u>											
A. Minimum	Range, azimuth, elevation	Yes	Yes (C)	Yes	1	Deliver type can	Automatic	Digital	10 M range 1 mil angle	Transponder required for adequate precision for FAR 36 airports. Can operate with track for experimental purposes.	\$300-\$700K
B. Advanced	Range, azimuth, elevation	Yes	Yes (C)	Yes	1	Track and	Automatic	Digital	5 M range 0.1 mil angle		\$1 - \$2M
<u>Laser</u>	Range, azimuth, elevation	No	Yes	Yes	1	Track	Automatic	Digital	± 1 M range ± 0.5 mil angle		\$425-\$750K
<u>RF Sampling and Telemetry</u>	Range to multiple stations	Yes	Yes	Yes (C)	Multiple	Battery powered	Automatic	Digital	Range accuracy ± 10 feet	For real time data a data link between aircraft with master interrogator and ground would be required.	\$40-\$60K
<u>Optical Theodolite</u>											
A. Minimum	Azimuth and elevation from minimum of two sites	No	No	No	2	Tripod battery powered	2 operators	Digital (C)	1 mil angle	Normally would be used with film backup for corrections for operator errors.	\$70-\$150K
B. Advanced	Azimuth and elevation from minimum of two sites	No	No	Yes	2	On trailer	2 operators	Digital (C)	0.0025° angle (C)		\$600-\$800K
<u>Ground Camera</u>	Range and angle	No	No	No	Multiple	Yes	Yes (C)	Film	15 range	Could be automated.	\$2-\$10K
<u>Aircraft Camera</u>	Range and angle	No	Yes	No	Multiple	Yes	No	Film	15 range	Requires ground bases at precisely known locations spaced so that one is always in view.	\$2-\$10K
<u>Combinations</u>											
<u>System 1</u>											
<u>Radio/TV Theodolite</u>	Range, azimuth, elevation	Yes (C)	Yes (C)	Yes (C)	1		1 operator	Digital		TV theodolite provides precision optical tracking of aircraft without transponder attached to aircraft. All weather in radar mode.	\$350-\$800K
A. Minimum	Range, azimuth, elevation	Yes (C)	Yes (C)	Yes (C)	1	Yes, van	1 operator	Digital			
B. Advanced	Range, azimuth, elevation	Yes (C)	Yes (C)	Yes (C)	1	Track and trailer	1 operator	Digital			\$1.2M-\$2.2M
<u>System 2</u>											
<u>Optical Theodolite</u>	Range (RF), azimuth, elevation	No	Yes	Yes	1	Battery powered	1 operator	Digital			\$85-\$150K
A. Minimum Theodolite	Range (RF), azimuth, elevation	No	Yes	Yes	1	Trailer	1 operator	Digital			\$300-\$750K
B. Advanced Theodolite	Range (RF), azimuth, elevation	No	Yes	Yes	1						

* Each ground station position must be accurately known.

** Digital signal can go directly to the computer or be recorded on magnetic tape.

(C) means see Comment column.

4.2.1 Radar Target Skin Tracking

Two modes of radar operation have been considered in the present study: skin tracking and beacon tracking. In the conventional skin tracking mode, the radar system operates solely on the radar echo reflected by the target aircraft (with the entire "skin" of the aircraft contributing to the reflected signal). In beacon tracking, the aircraft must be specially equipped with a microwave transponder or beacon which transmits a pulse signal in response to interrogation by the ground-based radar.

Skin tracking is attractive in that it can apply to all aircraft, and requires no modification or additional equipment aboard the target aircraft. Nevertheless, it is doubtful that simple radar skin tracking, regardless of the level of sophistication of the tracking radar system, will be satisfactory in meeting the accuracy requirements in the present application.

The tracking performance advantages of a high resolution, narrow beam radar are lost whenever the target subtends an angle comparable to the antenna beamwidth. It is difficult to define the accuracy obtainable by skin tracking of a large aircraft at a range of 6 miles or less. The azimuth and elevation tracking accuracy at such distances is not determined by the angular resolution of the radar system, but instead depends heavily upon the complex reflection characteristics of the target aircraft.

If one observes the typical behavior of a radar which is skin tracking a close-in aircraft, it will be noted that the radar tends to wander erratically over the aircraft structure. At some times the radar may appear to be tracking a specific segment of the aircraft (e.g., nose section, wing root, or

nacelle). Strong specular reflections may be occasionally obtained from extended sections of the aircraft (e.g., leading edge of one wing). At such times the angle tracking servos of the radar may be violently perturbed, in an erratic and unpredictable manner.

Although quantitative accuracy values cannot be established for the situation involving a large aircraft target at relatively short ranges, it appears reasonable to assume that angle tracking errors can approach approximately the physical limits of the aircraft structure. Thus, for a multi-engine jet aircraft on an approach glide path, angular errors corresponding to the physical size of the aircraft may represent height errors of 25 feet and lateral path errors in excess of 75 feet. Furthermore, there can be no assurance that substantially larger errors will not occur occasionally, thus reducing the validity of the tracking measurements.

4.2.2 Radar Beacon Tracking

The intrinsic tracking capabilities of a precision radar can be largely realized by utilizing a suitable beacon transponder on the aircraft. Modification to the aircraft includes the installation of a beacon antenna and receiver-transmitter unit. The antenna can be a simple dipole stub, extending only an inch or so from the fuselage; nevertheless, its mounting, as well as installation of the receiver-transmitter unit, may present a problem on some aircraft.

It should be noted that the standard ATC transponder, operating in the 1.1 GHz frequency region, cannot fully fulfill the accuracy/precision requirements in the present tracking application. Accordingly, it is necessary to install an additional beacon, preferably in the Ku or an even higher band to achieve higher resolution. The ground-based receiving antenna

should have a sufficiently narrow beam width that ground reflections are negligible when tracking an aircraft at an elevation of 3° or even lower; this implies the utilization of the shortest possible wavelength, together with a relatively large aperture ground antenna, so as to achieve a vertical beam-width of, say 1° , with low side lobes.

In summary, radar beacon tracking with currently available precision radar systems offers an all-weather performance capability with an accuracy of 0.1-1.0 mil in both elevation and azimuth, and a range accuracy of the order of 5-10 meters. However, a major limitation in the beacon method is the requirement for modification of each target aircraft to incorporate the proper beacon.

4.2.3 Laser Tracking

Recent advances in laser technology have resulted in laser systems capable of automatically tracking aircraft at a range of 20 miles and with a positional precision measured in inches. However, this performance requires the installation of a retroreflector array on the target aircraft (typically, a hemispherical array of reflective prisms, roughly 8 inches in diameter and configured so as to give essentially a uniform retroreflected signal to the ground tracking system for all possible aircraft heading angles).

Laser "skin tracking" of an aircraft (without a retroreflector) is not practical. First of all, the maximum detection range is a few thousand feet at most; limitations on laser power output (to ensure eye safety for the aircraft crew as well as any other personnel who might be exposed to the laser beam) and detector sensitivity restrict the maximum operating range. Secondly, as in

the case of radar skin tracking, the automatic tracking circuits are severely disturbed by signal energy reflected from various sources on an extended target. The use of a high gain retro-reflector, resulting in an exceedingly strong reflected signal from an essentially point source, overcomes both of the above problems.

Lasers can provide optical-quality angular tracking in elevation and azimuth (resolution to ± 0.05 mil is readily possible); range tracking to ± 1 meter is also possible. Thus, a single laser tracking system installed in an airport area so as to have unobstructed view of aircraft during takeoff or landing, can satisfy the tracking accuracy requirements.

However, the visibility of the laser beam is limited by the same factors that affect optical visibility. Furthermore, the extremely narrow beamwidth of the laser system poses a severe problem in target acquisition. Even a brief interruption of laser tracking, as might be caused by the aircraft passing through a cloud layer or the retroreflector being momentarily obscured during an aircraft maneuver, results in a re-acquisition problem. For these reasons, it is highly preferable that laser tracking be used in conjunction with a TV, radar, and/or manual optical sighting acquisition system. Radar can be used as an aid in target acquisition for the laser system; furthermore, the radar system will be useful in maintaining proper tracking and in target re-acquisition if the laser system loses lock for any reason. Radar skin tracking provides sufficient accuracy to establish acquisition; the laser tracking system provides the precision data on aircraft location.

The laser tracking method has the same basic limitation as the radar beacon approach: the method can be used only with those aircraft that are suitably modified with a special signal

enhancement device. The retroreflector required in the laser approach is perhaps simpler to install than a beacon transponder (recent state-of-the-art advances in microwave solid-state technology make this point debatable).

4.2.4 Theodolite Tracking

Optical theodolites have been widely used for precision tracking of missiles, aircraft, and other moving vehicles. There is a wide range of available instrumentation. For routine tracking of weather balloons, for example, an inexpensive theodolite, tripod mounted and with a simple optical telescope, is employed. At the other extreme are the highly complex phototheodolites used for tracking and recording the trajectories of supersonic missiles or maneuvering target drones out to extreme ranges; these incorporate multiple telescopes (some having very large focal length, wide aperture lenses), precision drive mechanisms, and provision for cine camera recording of the target during tracking.

In each case, however, the basic tracking function is performed by an operator who controls the azimuth and elevation angles of the theodolite pedestal (either manually or through motor drive) so that the cross hairs of the telescope remain centered on the image of the target. (If perfect tracking is not maintained by the operator it is possible to apply compensations based on detailed analysis of the camera recordings which show the relative position of target within the calibrated field of the recording telescope. This analysis, of course, is time consuming and, consequently, should be avoided unless essential in achieving specific accuracy requirements.)

With this and all other tracking methods, it is desirable to have supplemental photographic recording that will permit detailed analysis and test data verification at a later date. Accordingly, provision should be made for

the installation of a suitable camera (with telephoto lens) on the theodolite. A 16 mm cine camera, with single exposure remote control, is recommended if the system is heavily utilized on a routine basis. A Polaroid-type camera may be satisfactory where only an occasional aircraft is tracked.

One configuration is a theodolite located close to the touchdown point, and the other located a mile or so away and to either side of the runway line extension. The aircraft location determination would now be based on the simultaneous measurement of the azimuth and elevation angles of the aircraft target as seen by the separate theodolites. This standard triangulation method avoids the measurement of aircraft "size." However, the use of two theodolites requires that the tracking be coordinated and azimuth/elevation data from the two theodolites be transmitted to some central location where it is processed so as to give required three-dimensional target location information.

Theodolite methods, properly instrumented, provide more than adequate tracking accuracy. The two-theodolite method requires two observers and some means of data communication between separated locations; also, the computational process is not trivial.

4.2.5 Photographic Camera Scaling

The flight path of an aircraft can be determined by conventional photographic means using either an aircraft-mounted or a ground-based camera. The ground-based camera approach has an obvious advantage in that it requires no addition or modification to the aircraft.

One simple method utilizes one or several upward-looking cameras installed at known locations along the takeoff or landing

approach path. A photograph is taken of the target aircraft as it passes through the camera field-of-view. The image size of the aircraft on the photograph provides a quantitative measure of the aircraft slant range from the camera (and height above the camera since the elevation angle is also available on the photograph). The optical system can be readily calibrated for each aircraft type so that simple measurement of the image size and position within the camera field-of-view determines both the height and x-y coordinates of the aircraft at that instant. An aircraft height accuracy of 1% can be achieved by the camera image-scaling procedure.

Either single or multiple photographic exposure during flyover can be employed. Multiple exposure, for example, at precise 1 second intervals would permit ground-based determination of aircraft ground speed and flight path. (The use of multiple exposures on a single photographic frame would result in some reduction in contrast and definition of the aircraft images against the sky background, but this effect could be minimized by the use of appropriate filters.)

A fixed camera possesses a limited field-of-view that is determined by camera orientation, lens focal length, and film dimensions. To cover an extended flight trajectory it is thus necessary to use several cameras, suitably spaced along the anticipated path, so as to provide quantitative measurements at selected locations.

A wide variety of cameras could be employed in this application. For example, a Polaroid camera would be appropriate if "instantaneous" recording and data reduction were required. A conventional 35 mm camera, operated manually or by automatic control, would be satisfactory for short-term or occasional operation with a moderate number of aircraft;

however, for fully routine recording of many aircraft on a long-term basis, it would be preferable to use a cine camera, either 16 mm or 35 mm, with a large capacity film magazine and single frame-by-frame control.

The recording camera technique is well suited for routine recording of all landing and takeoff aircraft on a daily basis. The camera instrumentation can be installed within a weatherproof housing and actuated by remote control. Weight, space, and power requirements are minimal; the instrumentation package can be easily installed on the ground, roof top, or other structure without extensive installation costs. By the addition of an auxiliary photoelectric sensor which would detect the presence of an aircraft passing through a specified flyover zone, it would be possible to have a completely automatic system that would provide a permanent record on all aircraft using that runway. Alternatively, a camera activation could be initiated by an acoustical sensor so that a camera record is obtained for any aircraft exceeding some specified threshold level.

4.2.6 Closed Circuit TV Camera

The remote monitoring capabilities of a vidicon TV camera system can be used to advantage in combination with any of the tracking methods described here. Thus, a vidicon camera mounted on the pedestal of a tracking radar system would enable remote visual monitoring of radar performance; in addition, the vidicon camera can be highly useful in initial acquisition of the target aircraft and in maintaining accurate angle tracking in those instances where radar skin tracking becomes erratic.

Similarly, a vidicon camera installed on a tracking theodolite would permit remote operator tracking of the aircraft

in azimuth and elevation. Aircraft range can be estimated, as in direct viewing through an optical telescope, by size of the aircraft image on a display monitor. The TV method, furthermore, has the advantage that a single camera frame may be selected and "frozen" on an auxiliary storage oscilloscope or video recorder at any time, thereby permitting the operator to make detailed measurements on a stationary image.

A TV camera system may also be useful in conjunction with the image scaling method using a vertical-looking recording camera. The angular field-of-view of the recording camera is necessarily narrow in order that the aircraft image cover a significant fraction of the available film width; a wide-angle TV camera, mounted by the recording camera, will enable the operator to locate and acquire the target aircraft well in advance of the flyover point. Furthermore, by observing the aircraft on the TV monitor, the operator can activate the recording camera at the proper time, thus ensuring that each photograph includes a full aircraft image within the camera field-of-view.

4.2.7 RF Ranging and Triangulation

The position of an aircraft in space can be determined using trigonometry if the distance is measured accurately from the aircraft to each of three ground stations whose locations are precisely known. In an RF ranging position locating system the range from the aircraft to the ground station is measured by determining the total time required for an RF pulse to travel from an interrogator on the aircraft to a ground transponder and return. Portable equipment to measure these ranges with a resolution of ± 10 feet is commercially available. Equipment that measures more precisely by using multiple RF frequencies and measuring the phase of returned signals is also available; however, its response time is too long to track an aircraft adequately.

An RF ranging system offers direct measurement of an important parameter, the slant distance to the measurement microphone(s). The basic geometry required for accurate measurement of height along the complete landing flight path requires several transponder positions. Additional transponders would be required to determine the cross track position.

Real time data at a central ground station requires a data link from the aircraft. The requirement for multiple transponder locations may present site selection problems, in addition to increasing the number of sites to be surveyed.

Both the transponder and interrogator for this system can be operated from automobile-type storage batteries. Real time data can be provided at one site on the ground by placing the transponder on the aircraft and the interrogator on the ground. This capability can be used to measure range to a measurement site directly, or it can be used in combination with other subsystems.

4.2.8 Special Tracking Systems

The ARTS III system does not provide aircraft position information with adequate precision for certification noise measurements. The ARTS III system range accuracy is approximately ± 370 feet, and the altitude reading is provided in 100 foot increments. The 1000 MHz transponder used by the ARTS III system on most aircraft could possibly be used as part of a precision locating system which used multiple receiving stations and computer data processing. Such a system would use hyperbolic navigation techniques and would require considerable development effort, since no hardware is currently available. The ARTS III system is a primary component of the national air traffic control network and therefore safety is a primary consideration. Although

technically feasible, any alteration of this system to obtain data outputs or additional interrogations of the aircraft transponder may not be practical because of safety considerations. A detailed analysis of the capabilities of ARTS III is beyond the scope of this project.

For research purposes, the ARTS III system could provide useful inputs of both position and aircraft identification. One access point that would provide limited tracking data (within 1/8 mile) and aircraft identification with a minimum change of interface is the 1400 baud data line between NAS En Route Stage A and ARTS III. A listen-only "tap-off" of the exchanged data, with a minicomputer to sort out the desired information, would be a very powerful research tool. The data messages exchanged between these facilities are described in the specifications.¹

4.3 Tracking Accuracy

The relative location of the positional data measuring equipment and the aircraft and acoustical measuring site affects the accuracy of the computed slant range from the aircraft to the acoustical measuring site. It is desirable to make slant range determinations at several acoustical measuring sites with a set of tracking hardware. This section discusses the effect of measurement equipment location on slant range accuracy. Worst case errors in slant range have been determined for several geometries, using the basic range and angular accuracy specifications of the tracking equipment. The two basic techniques of 1) Range, Azimuth, and Elevation Tracking, and 2) Triangulation by Multiple Range Stations are considered. Most of the hardware configurations whose basic accuracies are summarized in Table 4.1 fall within one of these basic types.

¹ARTS III Computer Program Functional Specification, Interfacility Data Transfer, NAS-MD-610, December 1975.

A maximum error of 6% in slant range corresponds to a noise level error of approximately 0.5 EPNdB, based just on spreading loss. This is postulated as a minimum desired accuracy. As a uniform basis for comparing the various tracking systems, the case of an aircraft arrival has been selected. The nominal slant range chosen for comparison is that which results from point N, shown in Figure 4.1, with an elevation angle of 45° . This is the situation chosen to represent the point of maximum noise and therefore is most critical for slant range measurement.

4.3.1 Range, Azimuth, and Elevation Tracking

Several of the tracking subsystems shown in Table 4.1 measure range, azimuth, and elevation. Each of these systems has its errors specified as range and angle errors. Once the measurement geometry is fixed, these basic errors can be translated first into rectangular coordinate system errors, and further into slant range errors. The landing geometry places the most stringent requirements on the measuring system, since the aircraft is close to the ground. In this situation a small absolute altitude error will result in a relatively large percentage change in the measured altitude. For example, at the certification measurement site for landing, the aircraft altitude 370 feet; for a 6% minimum range error the altitude must be known to within ± 22.2 feet. The absolute requirements are slightly less stringent at the 45° slant range point, which has been chosen to approximate the point of maximum noise.

Figures 4.4-4.6 show the calculated tracking errors for three different tracking subsystems, using the same aircraft approach geometry. Appendix B shows the procedure used to generate these plots. All range, azimuth, and elevation tracking subsystems have the desirable characteristic of requiring only one tracking site. The tracking site for Figures 4.4-4.6

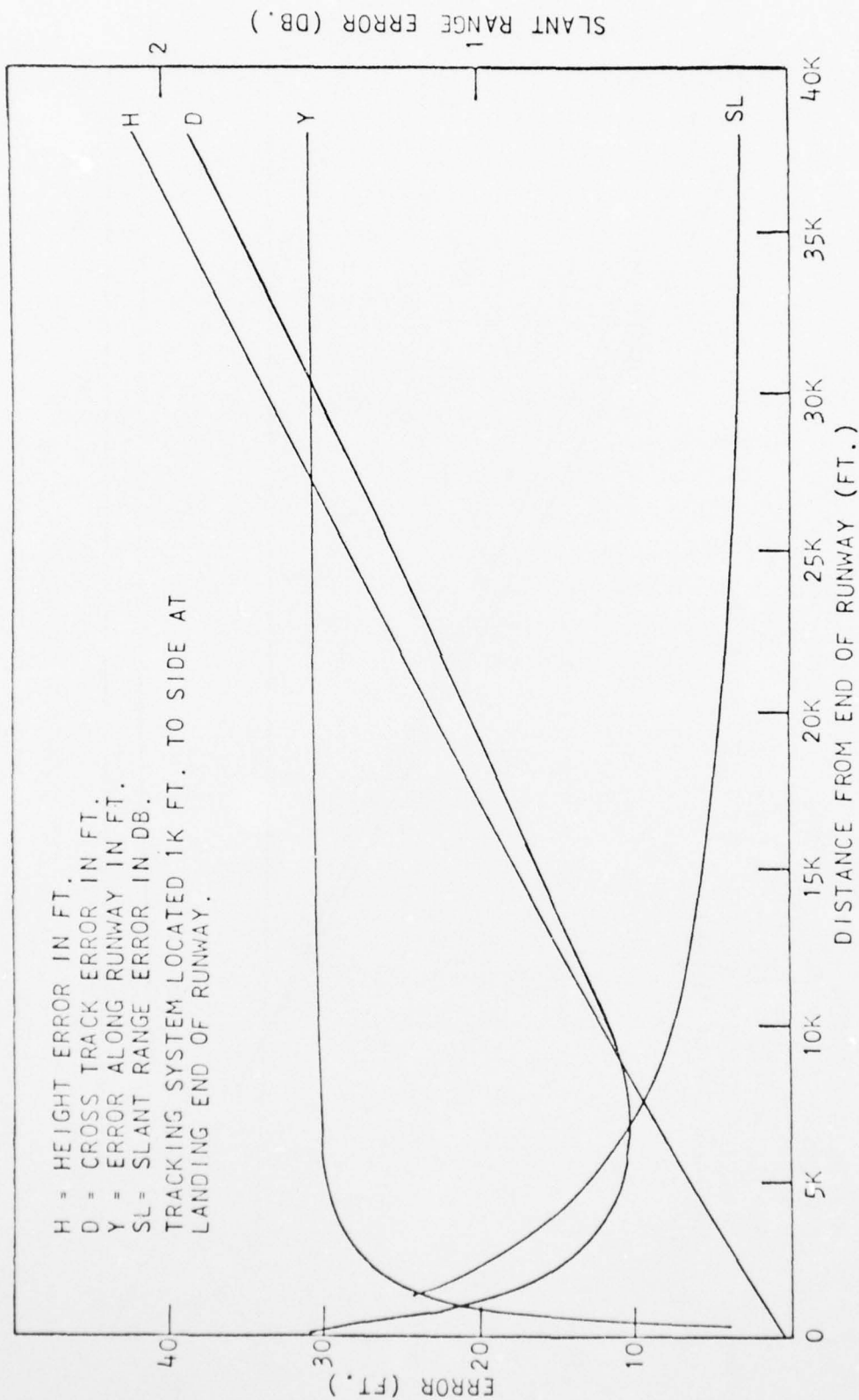

FIGURE 4.4 MAXIMUM TRACKING ERROR FOR A TRACKING SYSTEM WITH RANGE ACCURACY ± 30 FT. AND AN ANGULAR ACCURACY OF ± 1.0 MIL. FOR A NOMINAL 3 DEGREE GLIDE SLOPE ANGLE

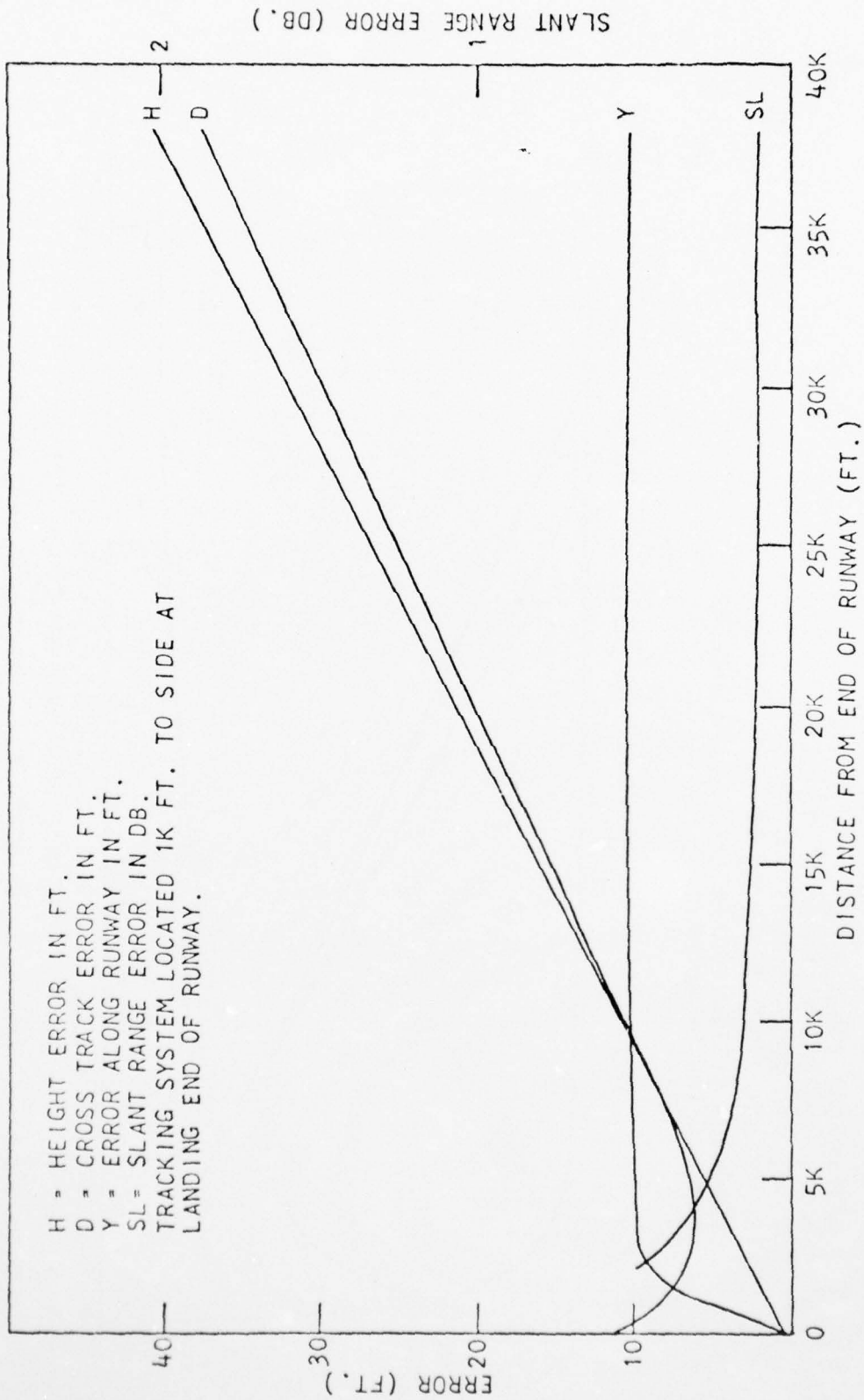

FIGURE 4.5 MAXIMUM TRACKING ERROR FOR A TRACKING SYSTEM WITH RANGE ACCURACY ± 10 FT. AND AN ANGULAR ACCURACY OF ± 1.0 MIL. FOR A NOMINAL 3 DEGREE GLIDE SLOPE ANGLE

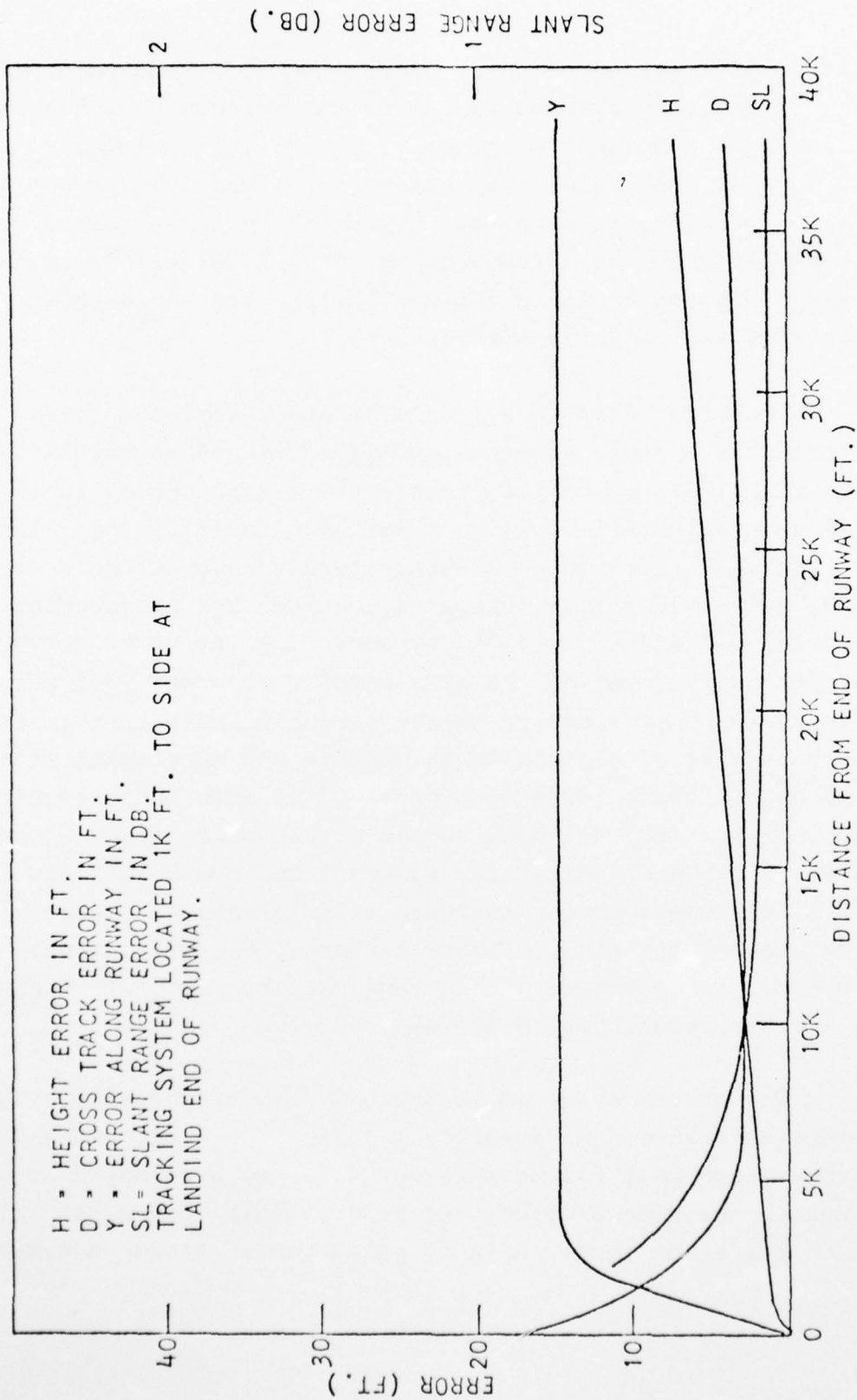

FIGURE 4.6 MAXIMUM TRACKING ERROR FOR A TRACKING SYSTEM WITH RANGE ACCURACY ± 15 FT. AND AN ANGULAR ACCURACY OF ± 0.1 MIL. FOR A NOMINAL 3 DEGREE GLIDE SLOPE ANGLE

is located 1000 feet to the side of the runway at the point of touchdown. The errors shown represent the maximum possible deviations from a nominal 3° glide slope for worst case combinations of tracking system errors in height (H), cross track (D), and distance along the runway (Y). These errors are shown together with the corresponding noise level error due to slant range (SL) uncertainty for a 45° elevation angle between the measuring site and the aircraft.

The error data in Figure 4.4 were calculated for a system that has a range accuracy of ± 30 feet and an angular accuracy of ± 1 mil (0.0562 degrees). This corresponds to the accuracy commonly available with a portable radar system. The system just meets the 0.5 dB accuracy requirement at the 1 nm measuring point. Figure 4.5 shows a considerable improvement in accuracy (0.24 EPNdB at 1 nm SL) by improving the range accuracy to ± 10 feet while keeping the same angular accuracy (± 1 mil). These data are representative of the portable radar with improved range accuracy or of a portable theodolite and RF ranging subsystem combination. A characteristic typical of azimuth and elevation systems when operated at small angles of elevation is that the distance error rapidly becomes a constant and the height and lateral displacement errors increase with increasing distance from the measurement site. Figure 4.6 shows the tracking system maximum error for a system with a range accuracy of ± 15 feet and an angular accuracy of ± 0.1 mil.

The errors shown in Figure 4.7 are for the same system conditions as Figure 4.4, accuracy ± 30 feet, ± 1 mil and a 3° approach, except that the measurement site has been moved to 5000 feet to the side of touchdown point. This change had little effect on the slant range, height, or distance errors; however,

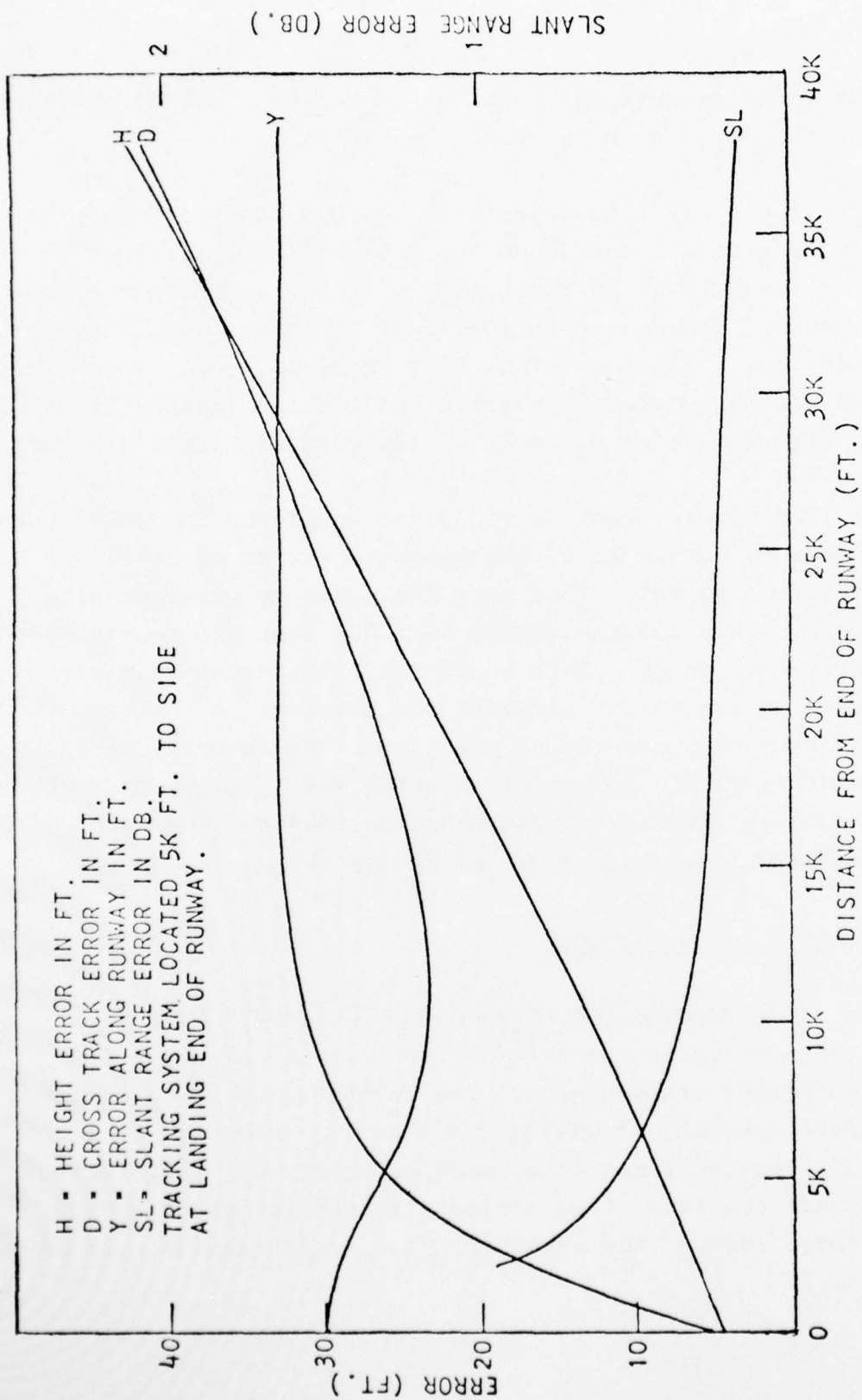

FIGURE 4.7 MAXIMUM TRACKING ERROR FOR TRACKING SYSTEM WITH RANGE ACCURACY ± 30 FT., AND AN ANGULAR ACCURACY OF ± 1.0 MIL, FOR A NOMINAL 3 DEGREE GLIDE SLOPE ANGLE AND 5K FT. SIDELINE DISPLACEMENT OF TRACKING SYSTEM

the cross track measurement accuracy is reduced. Similar effects occur for the more accurate measuring systems.

Figure 4.8 illustrates the calculated errors for the first portable radar considered for a takeoff that follows a simplified flight profile consisting of first a constant climb from the end of the runway to 1000 feet altitude at 8000 feet out, then a 4% climb. The resulting error in slant range is considerably less for this takeoff profile than for the landing profile used for Figure 4.7, as a result of increased aircraft altitude.

The errors shown in Figure 4.9 apply to the radar used for Figure 4.8, but moved to the opposite (start of roll) end of the 10,000 foot runway. This puts the radar measurement site 10,000 feet back along the runway and 5000 feet off to the side from the liftoff point. This condition illustrates what might be achieved by monitoring takeoffs and landings in the same direction from one measurement position. The accuracy in slant range is still within the required tolerance. In practice, the system would be limited by ground reflections to a certain minimum elevation angle determined by the antenna beamwidth.

4.3.2 RF Ranging Systems

An RF ranging system measures the range from a transceiver located on the aircraft to each of three ground-located reference transponders. The locations of the transponders are accurately known; therefore the aircraft position can be calculated from the three range measurements. The range measurement hardware consists of an aircraft interrogation unit with digital range readout and recorder. The interrogation unit can

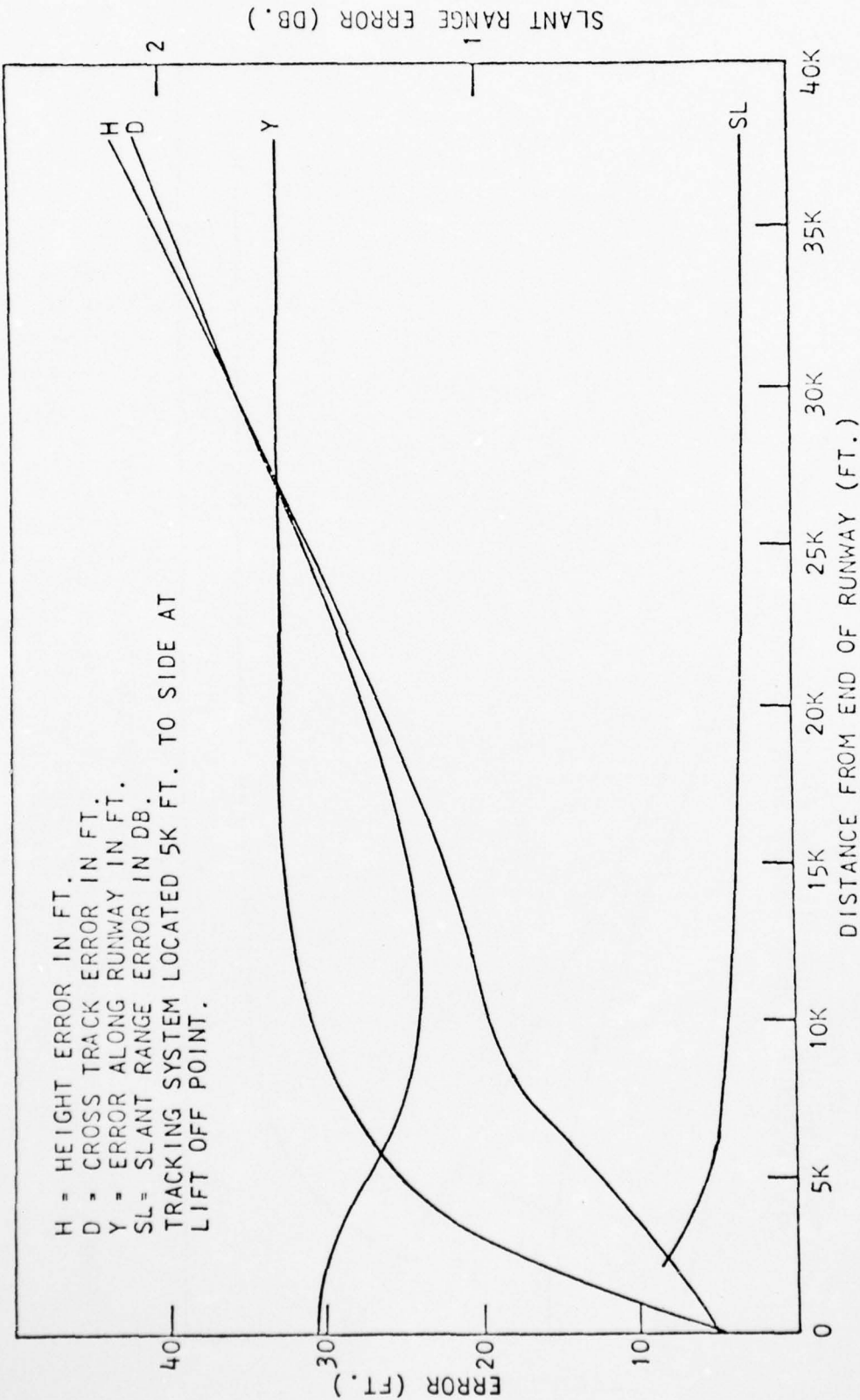

FIGURE 4.8 MAXIMUM TRACKING ERROR FOR A TRACKING SYSTEM AT LIFT OFF WITH RANGE ACCURACY ± 30 FT. AND ANGULAR ACCURACY $+1.0$ MIL. FOR A TAKE OFF WITH CONSTANT CLIMB TO 1000 FT. AT 8000 FT. FROM LIFT OFF THEN 4% CLIMB

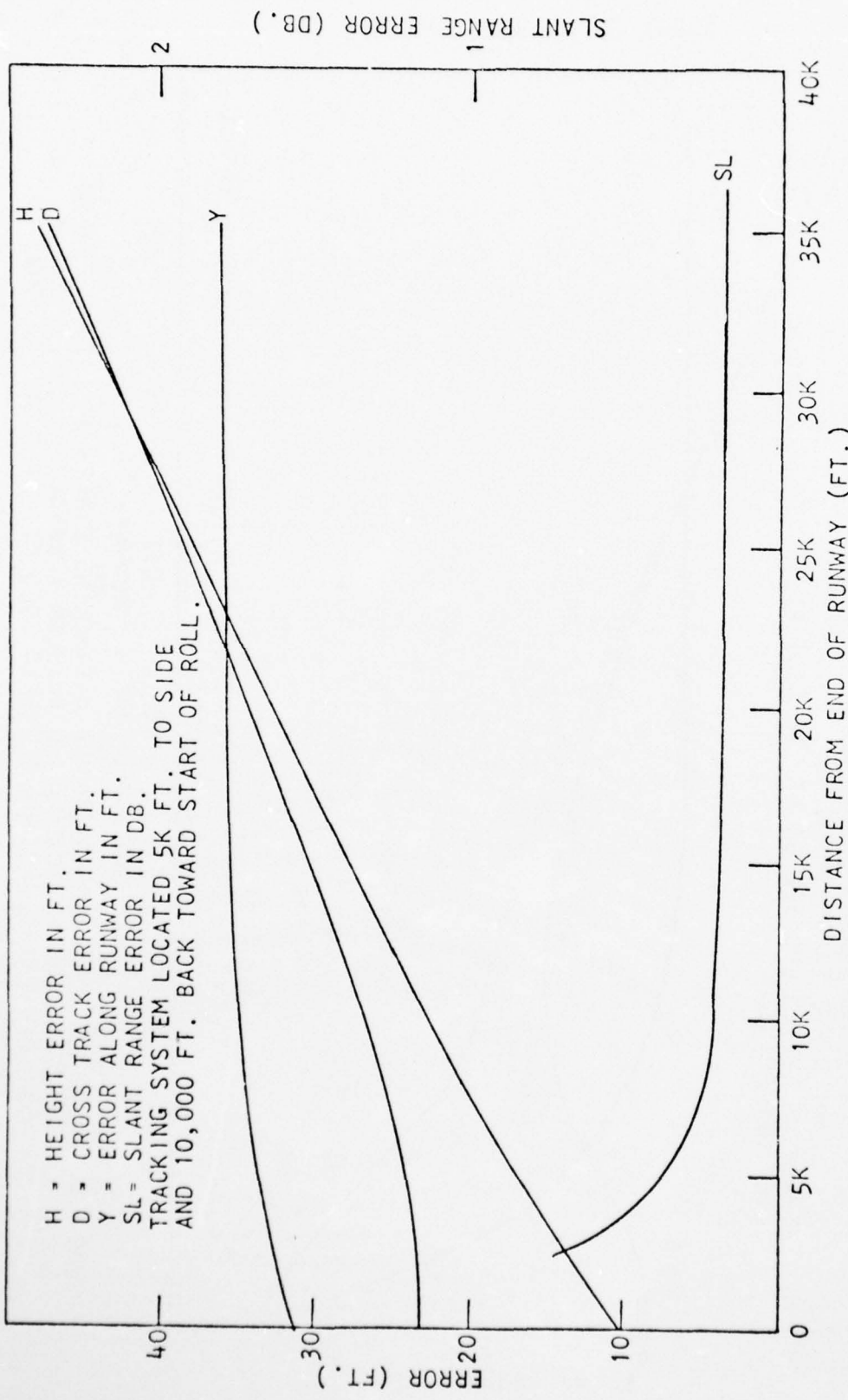

FIGURE 4.9 MAXIMUM TRACKING ERROR FOR A TRACKING SYSTEM AT START OF ROLL WITH RANGE ACCURACY ± 30 FT., AND ANGULAR ACCURACY ± 1.0 MIL. FOR A TAKEOFF WITH CONSTANT CLIMB TO 1000 FT. AT 8000 FT. FROM LIFT OFF THEN 4% CLIMB.

weigh less than 50 pounds and consume less than 50 watts of electrical power from a 24-30 volt source. The transponder weight is 5 pounds and its power consumption, 5 watts. This power requirement will allow several days of operation on two series-connected automobile storage batteries. The operating frequency can be either C- or X-band. Up to four separate address code transponders can be automatically scanned, or 16 can be manually scanned. The system is essentially a radar without angular measurement capability. Range is measured by measuring the round trip transit time of an RF pulse. Even when several pulses are averaged to improve accuracy, a single measurement of range takes only a few milliseconds.

The basic range measurement accuracy of the instrument is ± 10 feet. The actual accuracy achieved, as with all other systems, depends upon the geometry of the measurement situation. For the purpose of understanding this geometry in relation to accuracy, the two dimensional problem will be analyzed first. Figure 4.10 shows a typical two dimensional positioning system which uses one interrogator and two transponders. The distance from transponder A to transponder B is known, and the range measuring interrogator measures the range R_A and R_B . If the uncertainty in range measurement is small with respect to the actual range, a differential range error diagram can be constructed, as shown in expanded scale in Figure 4.11, by erecting perpendiculars FG, HD, FD, and GH about the nominal intersection point (interrogator location) each displaced a distance equal to the range resolution. The intersections of these perpendiculars form a zone of error.

The errors in a coordinate system having the line AB as an axis are E_1 and E_2 . The maximum error is E_3 . From this type of analysis it can be seen that the positioning error in

INTERROGATOR/RANGE READOUT



FIGURE 4.10 GEOMETRY FOR TWO DIMENSIONAL RF RANGING POSITION LOCATING SYSTEM

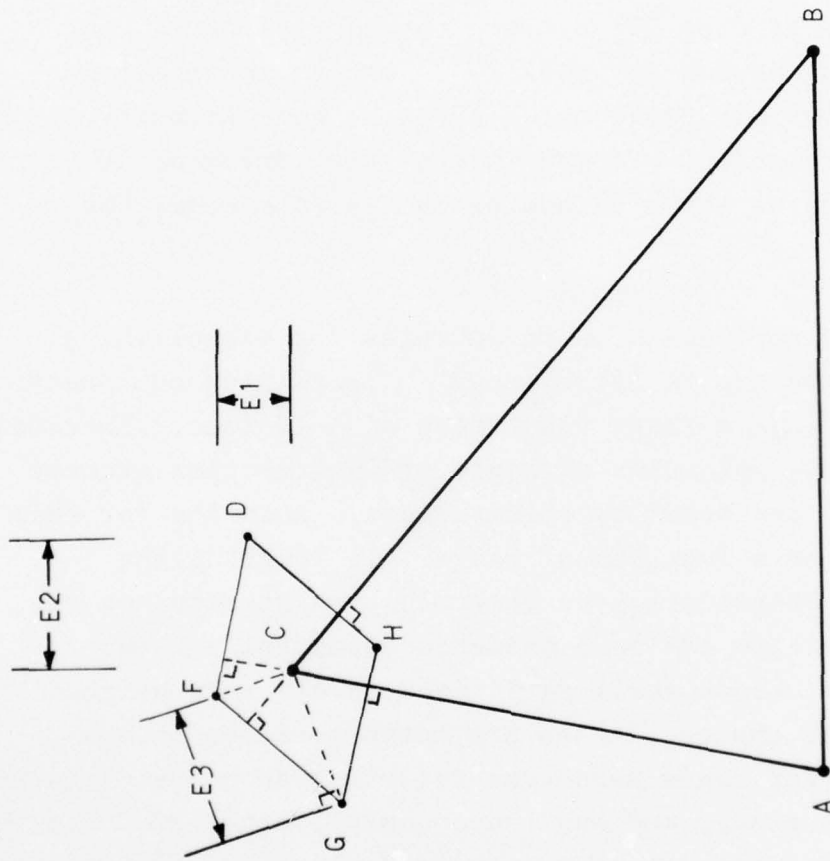

FIGURE 4.11 DIFFERENTIAL RANGE ERROR FOR A TWO DIMENSIONAL RF RANGING SYSTEM

any coordinate system is always greater than the basic range resolution. The shape of the error zone is controlled by the angle of intersection of the two range lines CA and CB. The error will be a minimum for an intersection angle of 90° and the maximum possible error will increase rapidly after the intersection angle deviates from 90° by more than 30° , that is, for intersection angles between 60° and 120° . For an intersection angle of 60° , the maximum positioning error is approximately twice the range resolution. For an intersection angle of 30° , the maximum positioning error is approximately four times the range resolution.

From this analysis some basic rules for establishing transponder locations can be established. The ranging equipment under consideration has a range resolution of ± 10 feet. Therefore a system which always maintains an angle of intersection greater than 60° would meet the accuracy requirements. Accuracy for this type of system is not a function of range. In locating the position for the transponders, the determination of distance out and cross track position can be considered essentially a two dimensional problem, since small variations in aircraft height result in negligible changes in the projected position in the horizontal plane. For these measurements, one transponder located near the end of the runway and one transponder located 20,000 feet to each side of the extension of runway centerline and 20,000 feet out would suffice to determine cross track and position along the extended centerline. This arrangement would provide adequate coverage to beyond 40,000 feet from the end of the runway.

The determination of the third dimension, height, presents an entirely different geometry problem. Consider the two-dimensional problem of locating the aircraft in a vertical plane passing through the extended runway centerline. For approach operations, the aircraft will be close to the ground.

AD-A042 798

TRACOR SCIENCES AND SYSTEMS AUSTIN TEX
PRELIMINARY DESIGN OF AN AIRCRAFT NOISE MEASUREMENT SYSTEM FOR --ETC(U)
JAN 77 B K COOPER

F/G 1/3

DOT-FATGWA-3900

UNCLASSIFIED

TRACOR-T75-AU-9531U

FAA-RD-75-217

NL

2 OF 3

AD
A042798



The approach condition presents the most difficult measurement problem, since the height accuracy must be great in order to maintain a small percentage error in height. Ten transponders, spaced along the extension of the runway centerline, are required to measure the aircraft height when the 60° minimum intersection angle is maintained.

The cost of multiple transponder units relative to other tracking systems is relatively low; however, the precision surveys and difficulty in obtaining multiple sites with no obstructions may present problems in many locations. In applications for which it is not necessary to measure the altitude accurately at all distances out to 40,000 feet from the end of the runway, but for which only accurate spot measurements are adequate, this system offers several advantages. When the primary distance of interest is the slant range from the aircraft to a measuring microphone location, the transponder can be located at the measuring microphone site for a direct measurement of slant range. This system can also be used to determine range in a combination system using other techniques to measure angles. When only one range measuring site is required, the interrogator can be ground located and the transponder mounted on the aircraft.

4.4 General Performance Considerations

"Real world" conditions must be considered in choosing a tracking subsystem, once the technical performance requirements are established. Official certification measurements are made only once for an aircraft configuration; therefore a system would be used rarely for this purpose. Although official measurements are made infrequently, aircraft manufacturers make frequent tests to determine the effects of engine modifications and other variables. The amount of testing and amount of data required will

influence cost versus performance tradeoffs. Most aircraft manufacturers currently have tracking systems or ranges capable of determining aircraft position adequately for certification tests. Each such range is geared to the respective level of testing activity. These ranges are usually used also for other performance tests. In addition, there are government-owned facilities that may be leased which have theodolite, radar, and laser tracking capabilities. Radar, laser, and RF range tracking equipment may be leased from commercial organizations. Therefore for a limited series of tests, the lease of an existing system would be very cost effective.

The tracking subsystem requirements for a research system depend on the envisioned research objectives. The selection of an appropriate system should be made according to the previous discussions after consideration of additional inputs such as the following:

- a. Feasibility of placing a transponder or retroreflector on the aircraft
- b. All weather operation or clear weather operation only
- c. Requirement for real time data
- d. Cost
- e. Portability
- f. Ease of setup and number of stations required
- g. Operating labor
- h. Documentation of data

i. Control of subject aircraft

j. Accuracy

Design examples of tracking subsystems for specific requirements are given in Sections 8.0 and 9.0. Appendix B illustrates the procedures used to calculate the tracking accuracy curves.

5.0 WEATHER DATA SUBSYSTEM

Sound propagation and attenuation between the aircraft and the ground measuring point are affected by temperature, humidity, wind direction, wind speed, and barometric pressure. For certification measurements in compliance with FAR Part 36, the temperature, wind speed, wind direction, and humidity must fall within specified ranges. Additionally, corrections are applied to the acoustical data to account for variations in humidity and temperature between the aircraft and the acoustical measurement point. Periodic recording of the temperature/humidity variations as a function of altitude must be made so that the appropriate corrections can be applied.

There are many experimental studies that can be conducted to contribute to the understanding of the effect of weather on the noise measured on the ground from aircraft in flight. These encompass the range from controlled experiments on atmospheric attenuation to the measurement of the average noise level from normally operating flight in broad weather categories. These data could be used in planning noise abatement procedures and in equitable policing of these procedures.

5.1 Types of Measurements

Equipment is readily available for measuring and recording any of the five weather parameters that affect sound propagation. Complexity arises in measuring the parameters along the sound propagation path from the aircraft to each of several acoustical measurement sites. For some research objectives, ground weather measurements at the acoustical data sites or at a central location will suffice. For other research objectives and for certification tests, it is necessary to measure as accurately as possible the temperature and humidity

variation with altitude and ground location. These data may be extrapolated from periodic samplings using instrumented light aircraft or balloon-borne instrumentation.

5.2 Measuring Equipment

Standard instrumentation for measuring temperature, wind speed, wind direction, humidity, and barometric pressure with sufficient accuracy for noise tests is available from numerous vendors. Instruments with electrical outputs are available for recording using charts or digital recording media. Also, these instruments may be directly interfaced to a computerized noise data collection system for real time inputs.

Weather measurements in real time at each acoustical measuring site may be made by combining the weather data with the acoustical data in a digital multiplexer for transmission to a central monitoring site. For tape recorded data, a digital weather code can be added to the end of record block containing the calibration and background data.

Meteorological instruments mounted in a light aircraft can collect data over a wide area in a short period of time. Sensors are available with response time short enough for continuous recording of temperature, dew point, and atmospheric turbulence versus altitude.² The system is typically flown in figure-eight patterns around the microphone station to provide representative measurements of the propagation path zone.

Weather measurements as a function of altitude may also be made using weather balloons with expendable data telemetry

² McCollough, J.B. and Larry K. Carpenter. Airborne Meteorological Instrumentation System and Data Reduction. FAA-ARD-75-69, April 1975.

transmitters. Standard radiosondes and data receivers are available that measure temperature to an accuracy better than 1°C and humidity, better than 2%. Improved accuracy is probably not required for this application but may be achieved using data correction procedures. For special low altitude measurements in the vicinity of a noise measuring site an instrumented balloon could be tethered. Free balloon measurements are time consuming and are at the mercy of wind conditions, presenting launch site selection problems. Several releases may be required to obtain the required data with good accuracy.

The balloon position must be known in both altitude and ground location to obtain a complete temperature, humidity profile for each measuring site. The wind speed and direction information can be derived from the balloon tracking data. The balloon position may be determined by several means:

- a. two manual theodolites
- b. automatic laser tracker (as used for aircraft)
- c. one manual theodolite with laser ranger
- d. automatic radar range and angle tracking using a special two frequency transponder equipped radiosonde

The cost of a single radiosonde is in the range of \$50 to \$150 in quantities of 100. The simple tracking system (two hand-held theodolites) and telemetry receiver ground station would cost \$8000 to \$15,000. Completely automatic data collection and correction equipment is available, including a minicomputer and costing in the neighborhood of \$100,000.

Special weather measurement systems could be built if a large data volume makes them cost effective. Some techniques that offer unique capabilities are:

- a. instrumented drone (model) aircraft
- b. dropsondes
- c. instrumented model rockets
- d. special small balloons and radiosondes for short ranges

These systems are not fully developed for this application; however, the continuing technological advances in miniaturization of electronic equipment may facilitate further development.

The choice of weather equipment depends upon the specific measurement objectives of a research noise measurement system, and, in both weather and certification system designs, the optimal choice will be influenced greatly by the frequency of sampling and number of locations required for atmospheric soundings.

6.0 AIRCRAFT IDENTIFICATION AND OPERATIONAL PARAMETER RECORDING SUBSYSTEMS

An aircraft identification for the purposes of noise tests may include type, model, serial number, air carrier or owner, weight, pilot, and flight number. When only one aircraft is involved, such as in certification tests, the collection of the identification information is a trivial task; however, for research measurements, perhaps involving hundreds of different flights in one day, accurate identification of aircraft becomes a major task. The on-board recording of aircraft operational parameters such as engine operating conditions, airspeed, altitude, ambient pressure, and temperature, time-correlated with ground acoustical measurements, may be desired for controlled research projects. Also aircraft weight, engine parameters, aircraft configuration, and airspeed are required for certification measurements.

6.1 Operational Parameters

The operational parameters will be recorded on the aircraft and must be time synchronized with the ground acoustical measurements. The time may be provided by an on-board VHF FM receiver that picks up the time code transmitted by the central site time code transmitter or may be provided by an on-board precision clock which is preset to the time code before flight and checked afterward.

The operational parameters may be recorded by a camera that simultaneously photographs the cockpit instrument panel and a time display. Alternately the operational data may be recorded on magnetic tape along with a time code. This instrumentation is usually present for other tests when an aircraft is being readied for service and may therefore be available for certification measurements.

6.2 Aircraft Identification

The correlation of certain noise events with specific aircraft operations is required to accomplish many research objectives. The required detail of data will vary from confirmation that an event was actually caused by an aircraft and not some extraneous noise source, to detailed information such as aircraft type, flight number, air carrier, pilot, etc. Either of these tasks may be difficult to implement at a busy air terminal where simultaneous arrivals and departures are occurring on parallel runways. Under these conditions simultaneous noise events due to different aircraft operations may occur at several noise measurement sites.

Automatic separation of aircraft noise from background noise may be required when long term experiments are conducted. A similar problem is encountered with noise monitoring systems as described in the Task A report. Development and validation of techniques for separating aircraft noise from background noise in the monitoring environment could be a major task for a research system. Some techniques that could be evaluated are:

- a. Time correlation of noise events at several microphones placed in line along the flight path
- b. Analysis of noise signatures for duration, rise time, etc.
- c. Special filters and logic
- d. Signal correlation from two microphones
- e. Directional microphones and arrays

- f. Narrow-beam radar beacons aimed into the airspace above the acoustical measuring sites

The actual identification of the aircraft is difficult, and more so as the flight frequency increases. During many experiments, measurements may be made of aircraft under normal flight conditions; therefore, the aircraft will not necessarily be cooperating with the tests and cannot be relied on for special identification information. Noise events that have been screened to be possible aircraft events can be correlated through a time code with specific aircraft either in real time or after the fact.

Several sources of input information about a flight are:

- a. Visual observation of the flight operation can provide type, air carrier, runway, and approximate flight path.
- b. Radio communication between the control tower and the aircraft can be used to identify flight, air carrier, and runway.
- c. Tower logs contain various kinds of identification information, depending on the airport.
- d. Flight schedules can be used when limited numbers of flights occur or can be used to augment other information.
- e. The ARTS III system contains flight information and arrival and departure times; however, access to this information may be restricted by air safety considerations. Completely automated flight

identification is technically feasible using the information available on the ARTS III data busses.

The preferred technique for flight identification will depend on the specific experiment being conducted. The tradeoff of cost, manpower, and desired data must be made in each instance.

7.0 DATA PROCESSING SUBSYSTEM

This section establishes general performance requirements of the data processing subsystem, and presents some illustrative examples of hardware/software configurations which may be apropos designs for particular requirements. A detailed design of a noise research system satisfying both the general requirements and other specific requirements is given in Section 9.0 of this report.

A data processing system is essentially a collection of procedures which accept some input data and produce desired output. In the instance of aircraft noise measurement the input will consist of basic sensor and aircraft identification data, while the desired output may be thought of as a printed report containing various information. Procedures for collecting and transforming the input data may be manual or automatic, but certain performance requirements on the procedures can be specified by examination of overall information accuracy and capacity criteria.

In order to discuss performance requirements of the data processing subsystem, it is necessary to first describe the processes to be performed. Figure 7.1 illustrates the generalized information flow (arrows) between processes (boxes) considered in this project. The major subsystems previously described are controlled (enabled, disabled, positioned, etc.) by a SUBSYSTEM CONTROL process. The output of the major subsystems relevant to a particular flyover event at a particular measurement site is synchronized in time, then integrated into a noise event data packet by the DATA SYNCHRONIZATION AND INTEGRATION (DSI) process. This event data packet may also contain information identifying the particular aircraft flight which caused the event, generated by the AIRCRAFT IDENTIFICATION process. Note that the event data packet may contain information

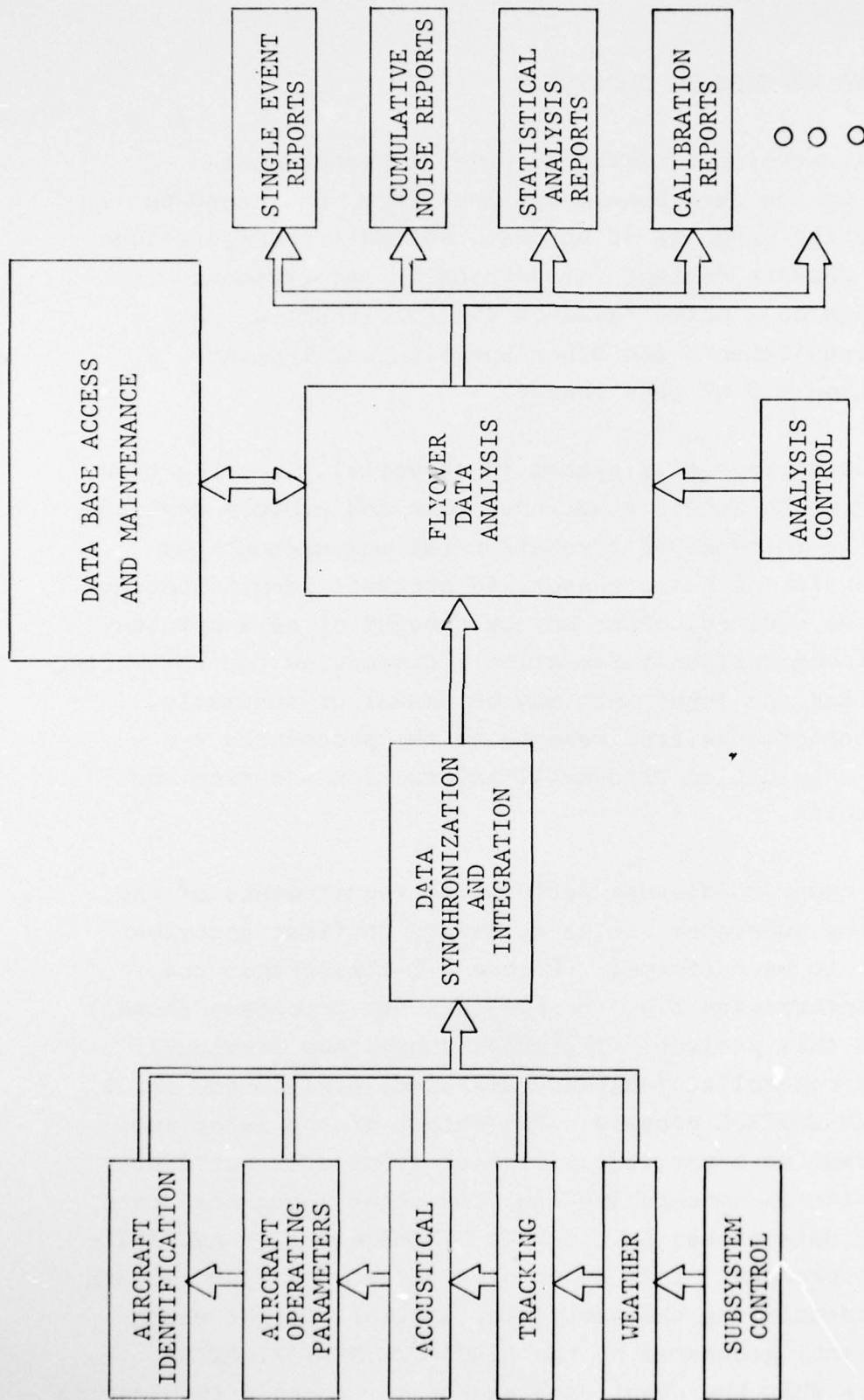

FIGURE 7.1 GENERALIZED INFORMATION FLOW DIAGRAM FOR AIRCRAFT NOISE MEASUREMENT DATA PROCESSING

peripheral to the actual aircraft flight data, such as weather stratification data or background noise level data, but coincident in time with the noise event.

The FLYOVER DATA ANALYSIS (FDA) process receives the event data packet and performs whatever computational analysis is desired. The analysis may be guided by an ANALYSIS CONTROL procedure, and will in general produce one or more types of report as the primary system output. Frequently it is desirable to reference previous data or collect new data at various stages of processing, so DATA BASE ACCESS AND MAINTENANCE (DBAM) is a common system function.

Each data process central to an aircraft noise measurement system may be implemented in a variety of ways. Figure 7.1 represents the logical design of any such system, which is independent of the degree of automation. In particular the processes described above may be implemented as operational procedures, computer programs, special purpose hardware devices, or some combination of each of these methods.

7.1 Performance Requirements

Not all of the functions described above necessarily involve complex hardware/software solutions. Writing an aircraft flight number on an analog (audio) recording tape box in the field and hand carrying the tape to a central processing site can provide the AIRCRAFT IDENTIFICATION subsystem as well as part of the DATA SYNCHRONIZATION AND INTEGRATION process for a certification system designed to handle a few hundred noise records per year. A large-scale research system installed at a major airport and handling several hundred noise records per day might require on-line aircraft identification from an operator, or from automatic interrogation of the ARTS III network, and might

integrate the identification data with other subsystem data using a real time computer system. The diversity of major subsystem designs which might be appropriate for particular implementation has been indicated in the previous sections of this report; this diversity yields a geometrically proportional diversity of possible data processing systems. Thus only the broadest of performance requirements can be stated without specific design constraints.

The following paragraphs describe the minimum performance required by the DATA PROCESSING subsystem for implementation of an aircraft noise measurement system. The primary assumptions are that any system considered is capable of performing aircraft noise measurement (i.e., EPNL calculations) with a degree of automation sufficient for the load requirements of the particular system design, and that aircraft noise measurement is the principal function of the system.

7.1.1 Subsystem Input

The major subsystems all have digital output which is in turn input to the DSI process. The requirement for digital signal paths results from the required EPNL capability, which realistically requires a digital computer to be utilized for the FDA process. For data processing design purposes, any hardware required to get the subsystem input into digital form will be considered part of that subsystem. Although particular designs may omit one or more subsystems (other than the acoustical subsystem), the following can be considered reasonable minimum performance requirements for the incoming data:

- 1) Error rates. Data errors can be introduced in any digital transmission scheme, and should not be ignored. The overall transmission performance criteria shall be that the probability of undetected

data transmission errors shall be less than 0.1% per aircraft noise event, and that the probability of detected errors shall be less than 1%. The former requirement guarantees that less than one aircraft noise measurement result out of 1000 will include erroneous data from transmission errors; the latter requirement insures that no more than one out of every 100 flyovers must be re-processed or discarded because of discovered transmission errors. As an example, a measurement system which contained only an acoustical subsystem might be required to have an undetected bit error rate in the raw data of less than one in 10^7 , given that a flyover event contains about 10^4 bits of one-third octave band data. This error rate is easily achievable for some transmission schemes (e.g., local coaxial cable or parallel digital signal lines), marginal for others (digital cassette), and unachievable without error detection and correcting codes for yet others (1200 baud voice-grade dial-up telephone lines). If more than one subsystem is utilized, all data transmission errors shall be considered in meeting the overall transmission performance criteria; however, it is expected that the acoustical data subsystem will be the area of major concern because of the large amount of data required per event.

- 2) Accuracy. The accuracy of the subsystem output shall not be affected by the data transmission scheme chosen.
- 3) Resolution. The resolution of the digital encoding scheme chosen shall be at least as great as the subsystem accuracy. If the acoustical system must be

linear within 0.1 dB in some intensity range, then the digital resolution of the acoustical data transmission system must be 0.1 dB or less in that intensity range; if temperature corrections must be made to the nearest degree Celsius, the weather subsystem transmission must resolve at least one degree.

- 4) Repeatability. The data transmission system shall function repeatably; that is, identical subsystem output must result in identical input to the data processing subsystem, within the error and accuracy constraints discussed above. This is a requirement for the data transmission system, but not necessarily for the individual subsystem input/output repeatability, where sampling processes may require more elaborate repeatability criteria.
- 5) Time Coding. Time information is extremely important in aircraft noise measurement for aircraft identification as well as data synchronization. Each input shall carry information sufficient to determine the exact time of each input datum within accuracies which must be specified for each subsystem. It is generally preferred that the subsystem input data be transmitted over independent, asynchronous data paths for maximum subsystem independence, so sufficient time information must be available for the DSI to synchronize the input data.

7.1.2 Subsystem Control

The SUBSYSTEM CONTROL function shown in Figure 7.1 controls and coordinates the major subsystems. Performance requirements for SUBSYSTEM CONTROL are so diverse that they must

be defined for the specific measurement system design. In any specific design, the SUBSYSTEM CONTROL function shall be specified in a manner which assures that the control function is achievable. In the case of a fully automated system, this control might be exercised by the DSI/FDA processes without manual intervention. Such a system might, upon detection of an aircraft, enable the real time analyzers, aim a radar antenna, automatically collect the data, and then disable the unneeded subsystems. In the case of a portable certification system, the SUBSYSTEM CONTROL might consist of verbal instructions to a technician detailing placement of data acquisition systems, and some type of telemetered control for turning the systems on and off.

7.1.3 Analysis Control

There shall be an ANALYSIS CONTROL function which controls any variable analysis path allowed by the system, or any interactive processing required. The input required by this function shall be minimal to prevent human error and to speed data processing time. When it is necessary to use previous results or tabular data to complete a process it is expected that these will be available from the DATA BASE subsystem and will not be re-entered through the ANALYSIS CONTROL system.

7.1.4 Data Base Access and Maintenance

There shall be provision for storing and retrieving computer-readable information which is to be used repeatedly in normal system processing. Examples of such data are atmospheric absorption coefficients, standard flight profiles, instrument correction factors, calibration data, and (whenever possible) report formats. It shall be easy to examine and alter any data contained in the data base.

7.1.5 Data Synchronization and Integration

The function of this system is to collect the incoming data from the major subsystems, extract data relevant to an aircraft noise event, and compose a data packet for processing by the analysis system. The data packet shall be carefully specified to insure that all desired system analyses can be performed from the data packet and information in the data base system.

The primary purpose for the DSI is to allow for flexibility in the data input system. It should be possible to incorporate changes in the configuration of any input subsystem by only changing the portion of the DSI directly concerned with that subsystem. For example, if it were desired to change from a radar tracking system to a laser tracker, the portion of the DSI handling the TRACKING interface might be changed, but the data packet output (and hence, the FDA and all other "downstream" processes) should remain unaltered. Any system design shall specify the methods used to insure subsystem independence and to perform input data reliability checks. The data packet shall be completely specified, and the types of analysis allowable with the specified data packet shall be listed. If the sensor data is needed for purposes other than noise event measurements, such as in the monitoring/research system described in Section 9.0, it may be necessary to move the data packet creation function to FDA to allow FDA easy access to raw sensor data.

One system capability which must be provided is bench marking, and the DSI is the preferred system for bench mark incorporation. Bench marking is comparable to calibration of an analog system. A bench mark is simply a program and all of its required input data which can be re-run after any system changes to demonstrate that the output is unaltered. As a minimum it should be possible to save selected data packets for later use as bench marks for the FDA system. A preferable procedure is to save all DSI input relevant to selected events so that both the DSI and the FDA may be bench marked.

7.1.6 Flyover Data Analysis

The heart of the data processing subsystem is the Flyover Data Analysis. As a minimum, the FDA is capable of performing EPNL analysis of "as measured" acoustical data. For a certification system, sufficient ancillary data and processing capability must be present to correct the "as measured" data to standard conditions. The minimum capability of EPNL analysis is sufficiently complex as to require some type of computer processing capability. A minimum measurement system might require no more than a laboratory mini- or microcomputer system, or might execute in batch mode on a large, general purpose computer system available for other uses. A complex research system could require the capabilities of a moderate to large dedicated computer system.

7.1.7 Output Reports

The system shall have the capability of generating reports suitable for permanent records. The reports to be generated constitute the most important output of the system, and shall be carefully designed to incorporate all relevant data in a concise, readable form. It is desirable that the FDA system be easily alterable to change the format of reports or to add new types of reports.

7.2 Data Processing Configurations

The following paragraphs describe hardware/software configurations which might be suitable for particular aircraft noise measurement tasks. The key factors in selection of a configuration are data reduction complexity and volume of data (number of flyovers) to be analyzed. All of the following configurations can be designed to meet the requirements of Section 7.1.

7.2.1 Stand-Alone Analyzer/Minicomputer

Figure 7.2 shows a typical minicomputer/real time analyzer configuration suitable for "as measured" analysis. This configuration and the software necessary for EPNL calculations are available as standard products from at least one U.S. manufacturer. This system is suitable for "as measured" analysis of perhaps 100 overflights per day, given the manpower to distribute and collect the analog tape recorders. This system could also be used for certification type measurements, but the enormous amount of data to be entered manually for correction to standard conditions would restrict the system to a throughput of a few site-flyovers per day. All of the functions shown in Figure 7.1 except the FDA are provided manually in this configuration; the FDA is a program executed on the system minicomputer.

7.2.2 Batch Processing Certification System

Figure 7.3 shows how a certification system might be implemented using intermediate tape and card storage and a batch-oriented central processing system. The acoustical and tracking systems, which produce large amounts of data rapidly, use digital magnetic tape for intermediate storage of the real time data. The weather and aircraft performance data are punched onto computer cards manually. The data processing is then performed by the central computer as a two-step process: first, the DSI system, a computer program, collects the data into event data packets; second, the FDA (another program) processes the packets and generates the required reports. The subsystem control is implemented by manual deployment of analog recorders and recording of aircraft parameters, etc.

A system of this design is capable of more certification measurements per day than it is possible to collect data for. The limitations of such a system are in long turn-around time and consequent lack of immediate indication of the proper function of

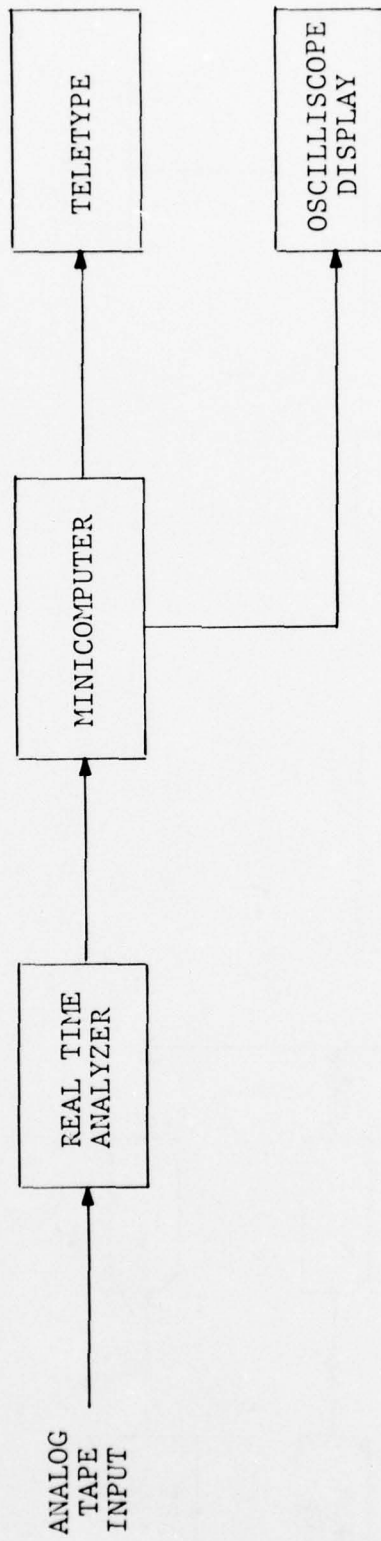

FIGURE 7.2 TYPICAL STAND-ALONE NOISE MEASUREMENT SYSTEM

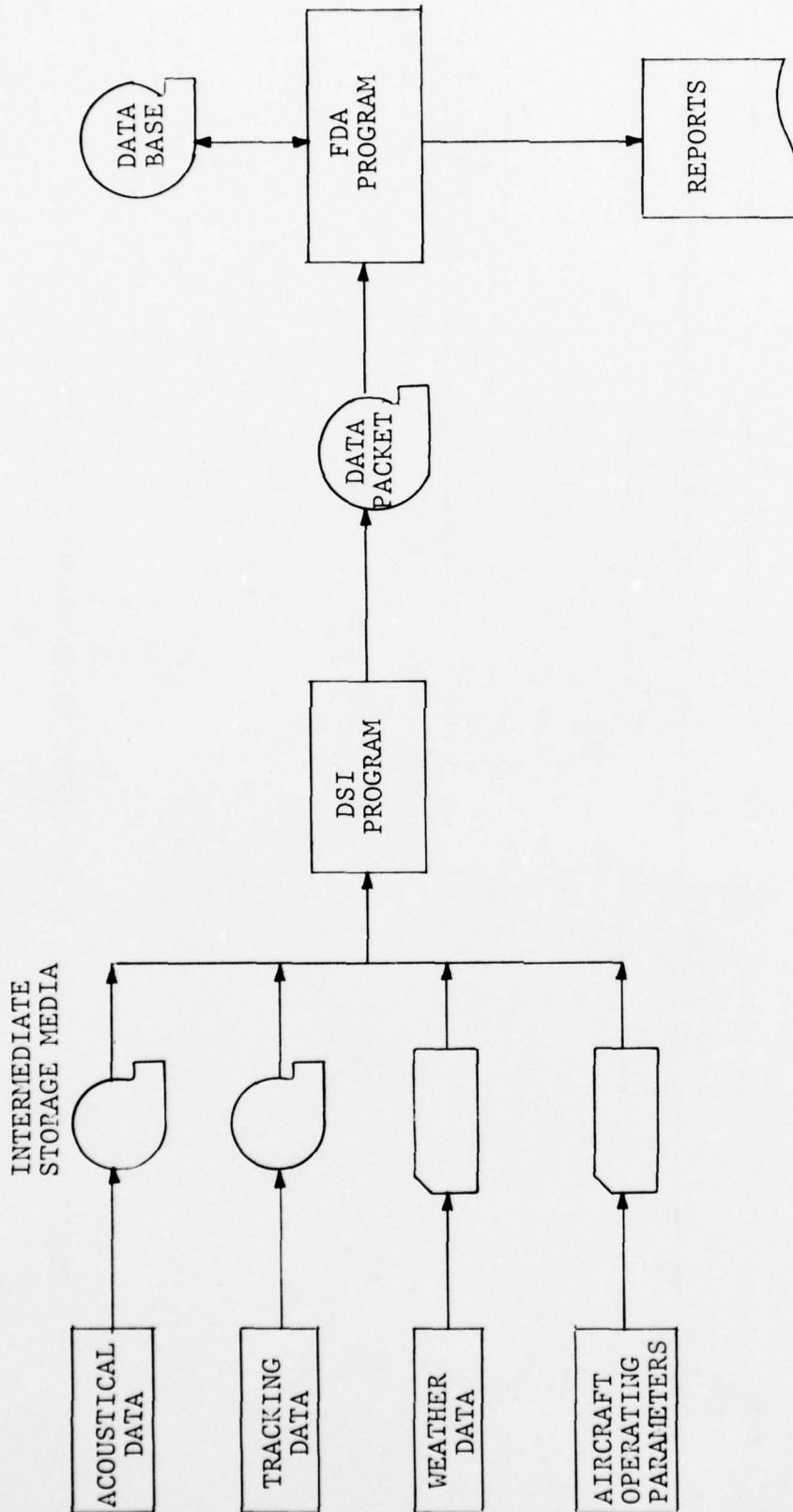

FIGURE 7.3 CERTIFICATION SYSTEM IMPLEMENTED ON A LARGE SCALE BATCH PROCESSOR

all subsystems. Research functions which require man-machine interaction are also difficult on this system, as is incorporation of a large number of measurement sites.

7.2.3 Dedicated Real Time Research System

Figure 7.4 shows a possible configuration suitable for doing automated data collection from a large number of measurement sites on a continuing basis for aviation noise research. The acoustical input comes from many measurement sites, while the aircraft identification is provided by manual input or by the ARTS III system. Other systems, such as surface weather, may be included as appropriate. The DSI and FDA functions are software processes performed on a dedicated (or possibly semi-dedicated) real time computer system of the large minicomputer size. The addition of an interactive terminal such as a cathode ray tube (CRT) terminal allows constant control of the analysis process when desired.

A system such as this would be excellent for collecting large amounts of aircraft noise data in an environment such as an airport. Modular expandability of the DSI would allow more accurate or additional subsystem input to be handled with relative ease. However, operation at an airport also implies that the aircraft measured are not likely to be either instrumented for operational parameter transmission or tracked by a high accuracy tracking system, so that certification-type measurements would not be a normal function for this system.

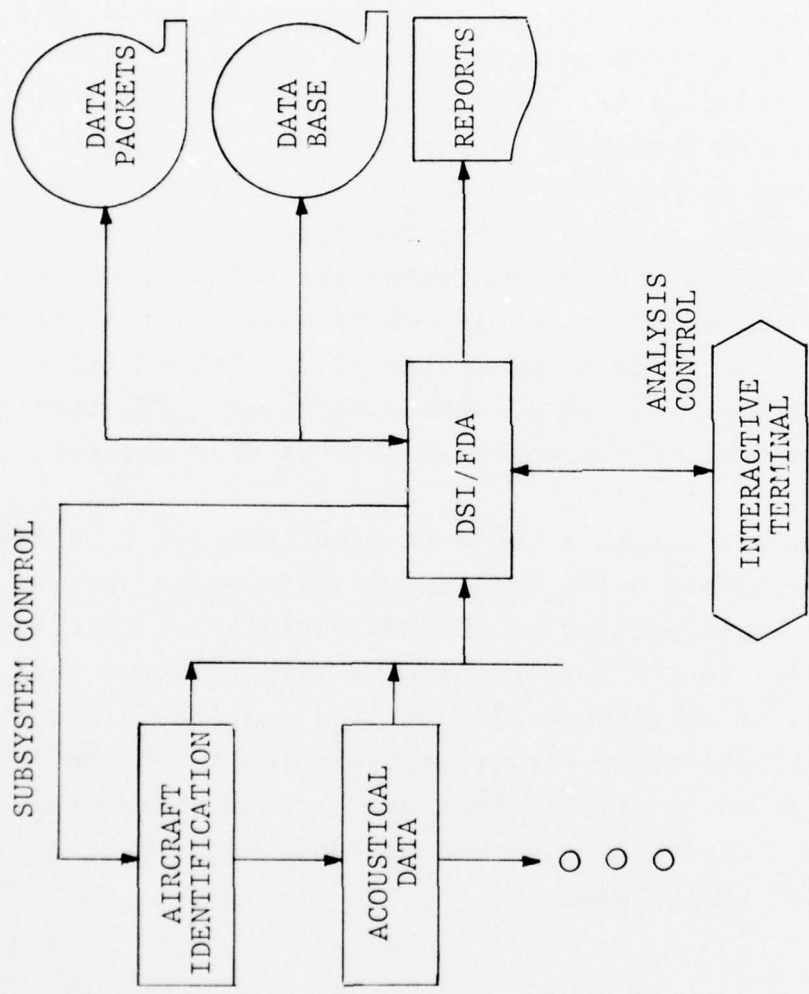

FIGURE 7.4 DEDICATED REAL TIME RESEARCH SYSTEM

8.0 A CERTIFICATION NOISE MEASUREMENT SYSTEM

A transportable certification noise measurement system is discussed in this section. Primary features are analog tape recording of the acoustical data at the measurement sites using battery powered equipment, precise laser tracking of aircraft position, and a stand-alone data processing system. This system could be taken to an airport and set up in approximately two days. The configuration was chosen to be an illustrative design example that includes all the required subsystems. It may be possible for a particular user to eliminate some subsystems by choosing a test site that already has tracking facilities installed for other purposes or by utilization of existing computer facilities for data reduction.

8.1 Design Considerations

The certification system requirements are greatly influenced by the fact that the aircraft is being operated specifically for the purpose of making the acoustical measurements. This allows installation of such aids as retroreflectors and instrumentation recording devices in the aircraft. A given test sequence would normally consist of approximately ten flyover measurements spanning a few days time span with considerable inactive time between tests. Therefore it is reasonable to use manpower intensive analog recording techniques in which the equipment is deployed daily, the system is manually calibrated, and the resulting tapes are hand carried to a central processing site for analysis. Also, manual recording of weather measurement data is satisfactory.

Certification measurements are conducted using the measurement locations and procedures of FAR Part 36. This system will perform measurements according to the current version of FAR

Part 36 and the proposed rule making changes as attached in Appendix A. Equipment performance requirements of FAR Part 36 are reviewed in the various subsystem chapters.

8.2 System Configuration

A block diagram of the proposed noise certification measurement system is shown in Figure 8.1. The acoustical data recording equipment consists of a portable battery-operated tape recorder, microphone, preamplifier, and a portable FM transceiver for tape recorder activation and time code reception. The time code is broadcast continuously from a central test control location. The off/on control of the tape recorders could be accomplished using this same transmitter.

Eight acoustical data recording packages are recommended even though a certification measurement can possibly be made with as few as five sets.

A laser tracking system is proposed as the ideal system for determining the aircraft position to the required accuracy. It is mounted in an instrumentation van, thereby making it transportable. It only requires a tracking site and one man to operate; however, it requires a retroreflector (approximately 6 inches on a side) attached to the aircraft. The laser tracker may also be used to level itself and survey its own location in reference to the runway and to locate the acoustical measurement sites accurately. Tracking is automatic after manual acquisition of the target. A TV camera is provided to aid in acquisition and allow video recording for documentation. The laser tracker provides positional data in x, y, z coordinates in real time and records these on a digital magnetic tape along with a time code.

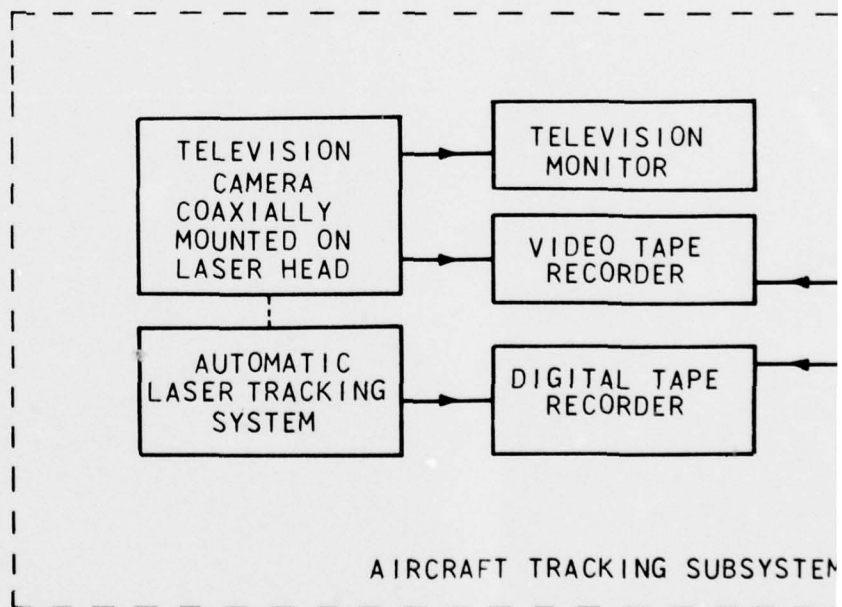
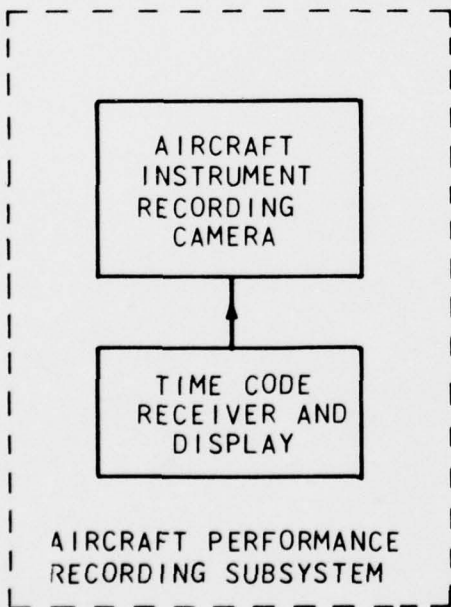
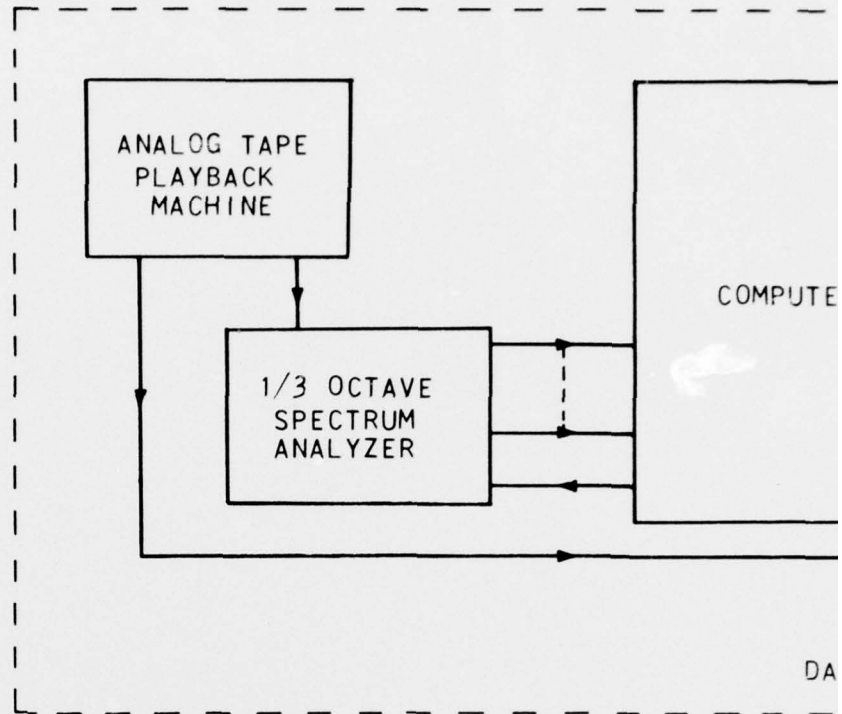
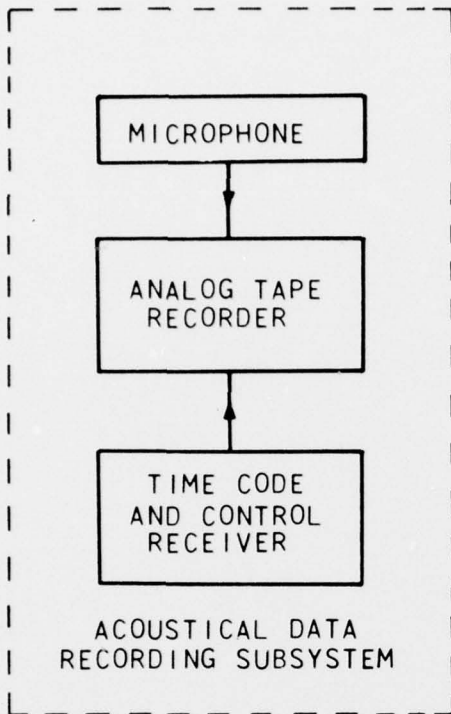
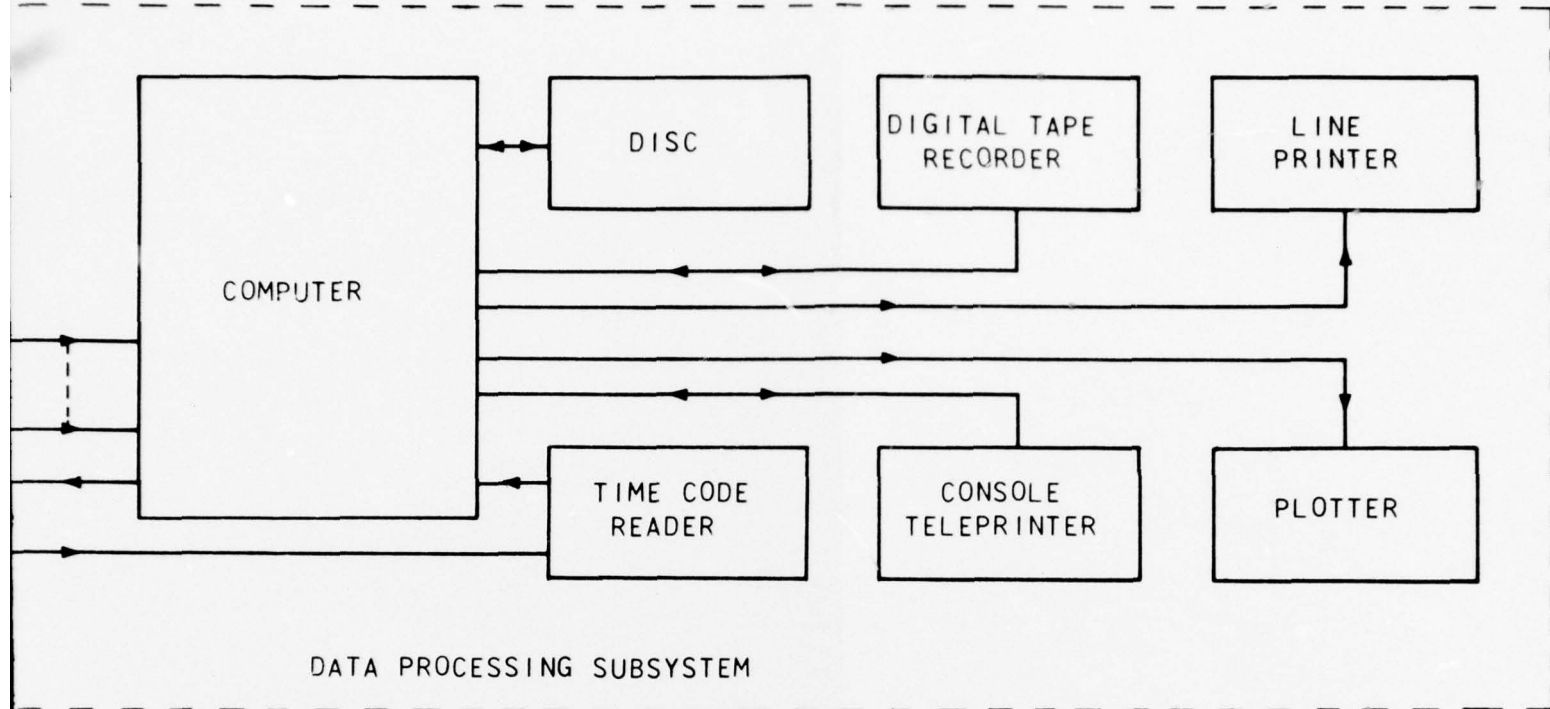
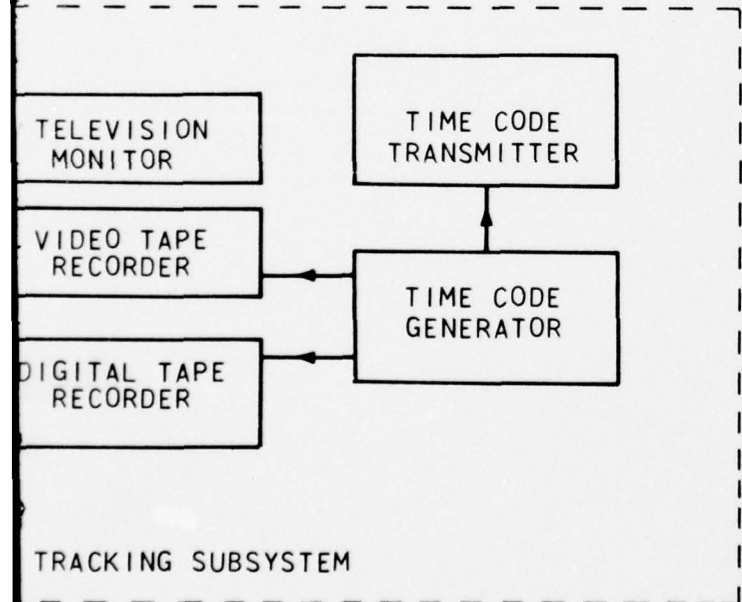

FIGURE 8.1 CERTIFICATION NOISE MEASUREMENT SYSTEMS



DATA PROCESSING SUBSYSTEM



TRACKING SUBSYSTEM

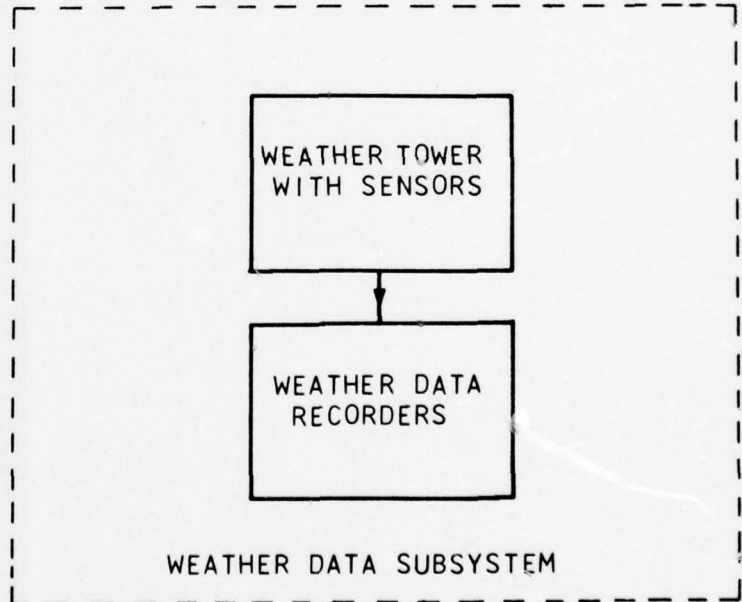

WEATHER DATA SUBSYSTEM

CATION NOISE MEASUREMENT SYSTEM BLOCK DIAGRAM

2

A portable telescoping ten-meter tower is provided for the weather instrumentation at one location. The wind speed, wind direction, barometric pressure, temperature, and relative humidity will be recorded on strip chart(s) from sensors mounted on the tower. Weather balloons are used to check for the existence of non-homogenous temperature/humidity conditions between the measurement sites and the aircraft position. A motion picture camera is mounted in the aircraft cockpit to photograph the instrument panel to document engine settings, etc. The aircraft clock will be set to the time code clock immediately prior to each test.

The analog acoustical data tapes and the digital tracking tapes are hand carried to the data reduction facility. The data reduction facility is a stand-alone minicomputer system which includes a one-third octave analyzer and time code reader. Data processing is accomplished in a sequential manner under software control. Data from the interim steps are stored in the disc memory. The processing is accomplished using straightforward system commands from the control console. The software is designed to merge the acoustical data with the tracking and weather data and perform the corrections according to the procedures of FAR Part 36. Printing and plotting of interim data and results are at the option of the operator. The final output is a corrected EPNL value for a flyover. The weather data are input by typing on the console the values with the appropriate times.

8.2.1 Acoustical Data Recording Subsystem

The block diagram of the acoustical data subsystem, given in Figure 8.2, shows an analog magnetic tape recorder as the basic data recording device. The tape recorder inherently limits the amount of data that can be collected without replacing the magnetic tape reel. For portability, a tape recorder using a maximum of 7 inch reels is suggested. This would provide 48 minutes

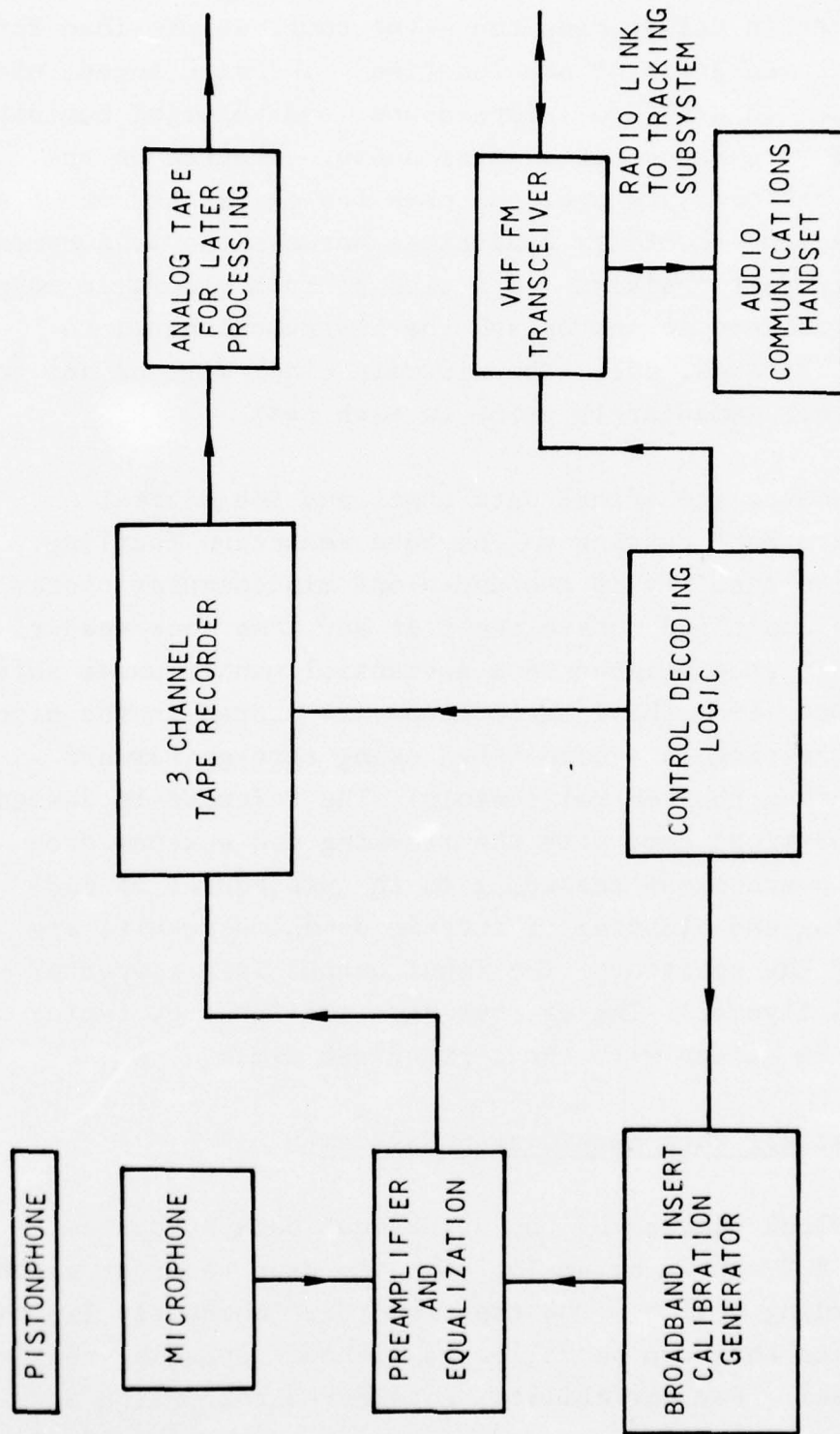

FIGURE 3.2 ACOUSTICAL DATA SUBSYSTEM BLOCK DIAGRAM

of recording time per reel at 7-1/2 inches per second tape speed. The tape recorder is a three track unit; two channels may be staggered in gain to cover a wide dynamic range and a third channel records the IRIG-B time code which is transmitted to the acoustical data collection site over a VHF FM data link. The FM data link can also provide a control signal to start and stop the recorder, or to insert the broadband electrical calibration signal. The FM transceiver is of the commercial portable walkie-talkie type. The combination of the portable tape recorder and small FM transceiver, both of which operate from internal batteries, coupled with minimum control and calibration circuits, makes a very compact measurement package. Required equipment for the acoustical data subsystem, together with the most relevant specifications, are given in Table 8.1. For this portable measurement package a standard laboratory 1/2 inch condenser microphone with a foam windscreen is the preferred microphone. The preamplifier equalization could be built into the tape recorder to minimize the size of the portable package.

8.2.2 Weather Instrumentation

A telescoping 10 meter tower that is about 3-1/2 meters long when contracted is used for mounting the weather instruments. These instruments accommodate the following ranges:

Relative humidity	0 - 100%
Barometric pressure	22 - 32 inches Hg
Wind direction	0 - 360 degrees
Wind speed	2 mph - 100 mph
Temperature	-40 - +120°F

The outputs are recorded on a chart for manual reading and entry into the data reduction system. Also, weather balloons are released and tracked, using the laser tracker to determine their position accurately, to obtain relative humidity and temperature data.

TABLE 8.1
EQUIPMENT FOR ACOUSTICAL DATA SUBSYSTEM

Name	Relevant Specifications and Characteristics
Microphone	1/2 inch condenser per IEC 179 (tripod mount)
Preamplifier	Preemphasis of 6 dB/octave starting at 2 kHz
Broadband Calibration Signal	Stability, ± 0.2 dB
Decoding Logic and Command	Calibration inject off/on Recorder off/on Standby for low power
FM Transceiver	Receiver sensitivity, $0.35 \mu\text{V}$ Transmitter power, 2 watts
Recorder	Record and playback response (direct) at $7\frac{1}{2}$ ips, 25 Hz to 20 kHz Signal to noise ratio, 60 dB Power, 12V at 240 mA

8.2.3 Tracking Subsystem

The laser tracking system is available from at least one vendor as a proven system. It is a convenient system to use because it operates from a single location and can be used to survey in its own position. It has a self-contained minicomputer

and therefore can do coordinate transformation and other convenient calculations. Real time printouts or plots may be provided to assist in determining if a run is a good one and to provide voice communication feedback to the pilot to guide him along the exact flight track desired. External electrical power is required for this system. It can be installed in a trailer 20 feet long that would also serve as the central control point for data collection. The system specifications are given in Table 8.2.

8.2.4 Data Analysis Subsystem

The hardware required for the stand-alone data analysis system is shown in Figure 8.1. This is a minicomputer system with the addition of a one-third octave band analyzer and time code reader. The requirement for the one-third octave analyzer were given in the acoustical data subsystem description in Section 3.3. The time code equipment is commercially available using several data formats. The Interrange Instrumentation Group, IRIG-B, format is ideal for this application. After processing of the analog tapes through the one-third octave band analysis equipment, the digital band level data are stored on the disc for merging with the other data. From this point on the data analysis equipment requirements are similar to those for the research system, even though the amount of data to be processed is less and no real time inputs are provided as they are in the research system. The pertinent specifications for this equipment are shown in Table 9.1.

8.3 Data Processing Software

The software provided with the system performs all the data handling, data manipulation, and printing necessary for EPNL calculations according to the procedures of FAR Part 36. System control is through the console printer by the use of short commands. The operator is not required to understand computer programming;

TABLE 8.2
TRACKING SUBSYSTEM SPECIFICATIONS

Parameter	Specifications
COVERAGE	
Azimuth:	+350°
Elevation:	-5° to +105° (dynamic specifications apply for -5° to +45° elevation)
Range:	25 nautical miles through touchdown and rollout (dependent on visibility conditions)
SYSTEM ACCURACY	
Azimuth:	+ 20 arc seconds at all ranges including touchdown and rollout
Elevation:	+ 20 arc seconds at all ranges including touchdown and rollout
Range:	+ 1 foot for target ranges out to 5 nautical miles + 2 feet for target ranges 5 to 10 nautical miles + 5 feet for target ranges at 25 nautical miles
MAXIMUM ANGULAR RATE IN AUTOMATIC MODE	
Azimuth:	500 mrad/sec
Elevation:	50 mrad/sec
MAXIMUM ANGULAR ACCELERATION IN AUTOMATIC MODE	
Azimuth:	80 mrad/sec ²
Elevation:	80 mrad/sec ²
DATA SAMPLE RATE	
	100, 50, 20, 10 samples per second (switch selectable)

TABLE 8.2 - Continued

Parameter	Specifications
DATA ENCODERS	
Azimuth:	18 bits
Elevation:	18 bits
Range:	18 bits
Az Error:	5 bits
El Error:	5 bits
LEVELING ACCURACY	
	± 0.025 mrad
ENVIRONMENTAL CONDITIONS (OPERATING)	
	Ambient temperature 0°F to 110°F
	Relative humidity 0 to 100%
	Wind 0 to 50 knots

however, the system is designed in such a way that a skilled operator can easily perform additional jobs not covered in the basic commands. This will require an operating system similar to the one discussed in Section 9.3, the requirements will not be repeated here. The research system discussed in Section 9.3 also has the capability of performing FAR Part 36 measurements; therefore all the subroutines required are included in that software discussion.

8.4 Summary Specifications and Costs

The performance features and costs of the recommended certification noise measurement system are given in this section.

This system was intended to be as generally useful as possible. In this respect it is totally self-sufficient as it does not depend on inputs from a separate tracking system or use of external computer facilities. In specific tests where existing recording, tracking, weather, and/or data processing equipment is available, the cost may be considerably reduced and the system configuration may be quite different and still meet the measurement objectives. Most of the practical subsystem approaches have been discussed in the preceding subsystem chapters.

8.4.1 Performance Characteristics

Acoustical data system:

- 2 track analog tape recorder
- 1/2 inch condenser microphone with windscreen
- Time code transceiver
- Data recorded on 1/4 inch magnetic tape

Tracking system:

- Laser tracking
- Only one site required
- Range 20 miles
- Accuracy: range, ± 1 meter
- angle, ± 0.5 mil
- Retroreflector mounted on aircraft
- TV system for acquisition and data recording
- Digital data output recorded on 9 track tape

Aircraft data system:

- Cockpit camera for monitoring instrument panel

Weather:

- 10 meter portable telescoping tower with relative humidity, barometric pressure, temperature, wind speed, wind direction instruments

Radiosonde balloons for recording temperature and relative humidity variables with height
Portable temperature, wind speed, wind direction, relative humidity instruments for site measurements

Software:

Flexible operating system capable of program development and editing

Application programs

- a. acoustical data analysis (one-third octave)
- b. merge acoustical, tracking, and weather data
- c. calculate PNL
- d. calculate EPNL
- e. apply position and weather corrections
- f. print and plot

(This program prints and/or plots the stored data, interim calculations, and final results. The operator has control, using simple keyboard commands, of results to be plotted.)

Data processing system:

Data inputs

Acoustical data from analog tape

Tracking data from digital tape

Other data and control through keyboard

One-third octave band spectrum analyzer

Time code reader

Disc

Minicomputer

Printer

Plotter

9 track digital tape deck

Control console

8.4.2 Costs

The cost of the recommended certification system would be between \$505K and \$1.25M. These costs include the purchase of the equipment and assembly of the separate equipment items into an operational system by a contractor. The lower price would be illustrative of a minimum system with limited operator conveniences. The higher price would include the purchase of more expensive hardware for all items thereby providing better system reliability and more convenient operation. Also the ultimate procurement specification and therefore the price will be influenced by the detailed task requirements, including how much the system will be used and where, as well as the importance placed on rapid data analysis and other system features.

The cost breakdown in Table 8.3 is for a complete system. The system cost is dominated by the cost of the laser tracker; however, this cost is justified in portability and accuracy achieved by this system in relation to any other alternatives. Other alternatives are given in detail in Section 4.0. Some lower cost tracking techniques can be used to meet limited objectives but for a complete FAR Part 36 system that would be used for actual certification tests the laser tracker is recommended. For a limited number of tests it would be possible to share the existing laser tracking system at NAFEC with other active programs or to lease a system from a commercial system owner.

The basic hardware costs for a typical certification system using good quality equipment is shown in Table 8.4. These costs represent the hardware shown in the block diagram of Figure 8.1.

TABLE 8.3

CERTIFICATION SYSTEM COSTS FOR SYSTEM
WITH 8 SETS OF ACOUSTICAL DATA COLLECTION EQUIPMENT

	Cost Range	
	Acoustical data set (total for 8 sets)	\$ 56K
Weather equipment*	15K	100K
Software	30K	150K
Data processing and recording central site	50K	120K
Tracking system	350K	750K
Aircraft performance data system	4K	10K
	\$505K	\$1.25M

*Radiosondes cost \$50 to \$150 each in quantities of 100 or greater.

TABLE 8.4
TYPICAL CERTIFICATION SYSTEM EQUIPMENT COSTS

System Component	Cost
<u>Acoustical Data Subsystem</u>	
Microphone	\$ 2 700
Tape recorder	5 300
Receiver and control (each site)	3 100
	\$ 11 100
<u>Data Processing</u>	
Analog tape recorder	\$ 5 300
One-third octave band analyzer	13 500
Computer	22 000
Time code generator/reader	3 500
Disc	16 900
Digital tape	6 500
Console printer	3 300
Line printer	3 500
Plotter	5 000
	\$ 79 500
<u>Aircraft Performance Subsystem</u>	
Cockpit camera	\$ 2 200
Time code receiver and display	5 500
	\$ 7 700
<u>Aircraft Tracking</u>	
TV camera and recorder	\$ 30 000
Laser tracker	425 000
Digital tape	5 000
Time code generator	3 500
Time code transmitter	1 800
	\$465 300

TABLE 8.4 - Continued

TYPICAL CERTIFICATION SYSTEM EQUIPMENT COSTS

System Component	Cost
<u>Weather System</u>	
Tower (portable)	\$ 1 500
Sensors	3 000
Recorders (strip)	3 000
Balloon receiver	5 200
Recorder digital and scanner	4 000
	<u>\$ 16 700</u>

9.0 A RESEARCH NOISE MEASUREMENT SYSTEM

A noise measurement system designed to meet a broad range of research objectives is described in this section. In keeping with the FAA responsibility in aircraft noise research, this system is directed primarily toward the measurement and study of aircraft generated noise in the vicinity of an airport and the effect on this noise of such variables as weather, aircraft flight procedures, etc.

This design presents overall performance capabilities and is not a detailed technical specification. Therefore specifications are given only where they contribute to the understanding of the system operation or are necessary to illustrate a capability. Specific research objectives were defined in Section 2.3.1. The system is capable of making measurements to FAR Part 36 requirements when augmented with special positional tracking aids such as a transponder, but is not especially oriented toward these kinds of tests.

9.1 Design Considerations

To meet the largest number of research objectives, it is obvious that data must be collected over long periods of time and thus that large volumes of data may be generated. These considerations dictate that a real time computer controlled data collection system must be used, capable of collecting data without operator intervention for 48 hours or longer. As in any research environment, flexibility and adaptability of the equipment is important. The needed flexibility is provided by the minicomputer through software control of the data collection and analysis process.

For versatility it should also be possible to manually enter time correlated data, such as aircraft type, into the system

and tie these data to specific noise and other events for later processing. The greatest flexibility in the acoustical data collection and analysis would be provided by having the raw 50 Hz to 10 kHz band acoustical data brought to the central data collection site. The transmission of these 100 dB dynamic range broadband acoustical signals from many measurement locations within a several mile radius of the airport presents technical and practical problems. However, at the cost of additional microphone site hardware (one-third octave analyzer and digital data transmission equipment) it is possible to reduce the data rate so that these data may be collected using standard voice grade telephone lines. Transmitting at a 1200 baud rate, the one-third octave band levels may each be updated every 0.5 second. This convenience is not achieved without some loss of capability. Specifically, there are experiments that require narrow band frequency analysis, greater than 0.5 second sample rates, fast averaging time, audio signal correlation, and audio tape recording of the broadband audio, none of which could be performed with this version of the system.

The remote microphone site hardware, including microphones, must be suitable for continuous operation in field environments. The duration of the experiments and permanency of the measuring site locations make it practical to provide telephone lines and electrical power to the sites.

Some of the research goals require that aircraft location be known as a function of time. As this system is intended to measure aircraft during normal operation at a busy airport, it is impossible to provide tracking aids on each aircraft. Therefore, a versatile tracking subsystem consisting of a 10 GHz radar, augmented by a coaxially mounted TV camera, was selected. In the auto acquisition, skin tracking mode, this system can provide real time data without an operator. Video

recording of the TV picture can be used for manual aircraft type identification. Several of the other tracking subsystems described in Section 4.0 provide unique capabilities that are ideally adaptable to specific research projects and should be used to augment this system as needed.

9.2 System Configuration

A complete block diagram of the proposed research system is shown in Figure 9.1. Each acoustical monitoring site is connected to the central data recording and analysis site by two voice grade telephone lines. One line is used for the digital data representing the measured acoustical and weather parameters. This data line also carries simultaneous digital control signals from the central site to the acoustical monitoring sites for control of such functions as calibration and analyzer gain setting. The second line carries the audio signal from the acoustical site to the central site for source identification and other purposes. The audio must be frequency band limited and amplitude compressed to be compatible with telephone line specifications.

The weather parameters of wind speed, wind direction, barometric pressure, temperature, and relative humidity are digitized and multiplexed into the same data stream as the digital data representing the acoustical levels. The data set transforms the serial digital data stream into a frequency modulated format for transmission over the telephone line.

The system is configured to accommodate up to 32 acoustical data sites simultaneously with some constraints in data processing as noted in a later section. The acoustical data site may be located anywhere that telephone lines and electrical power can be provided.

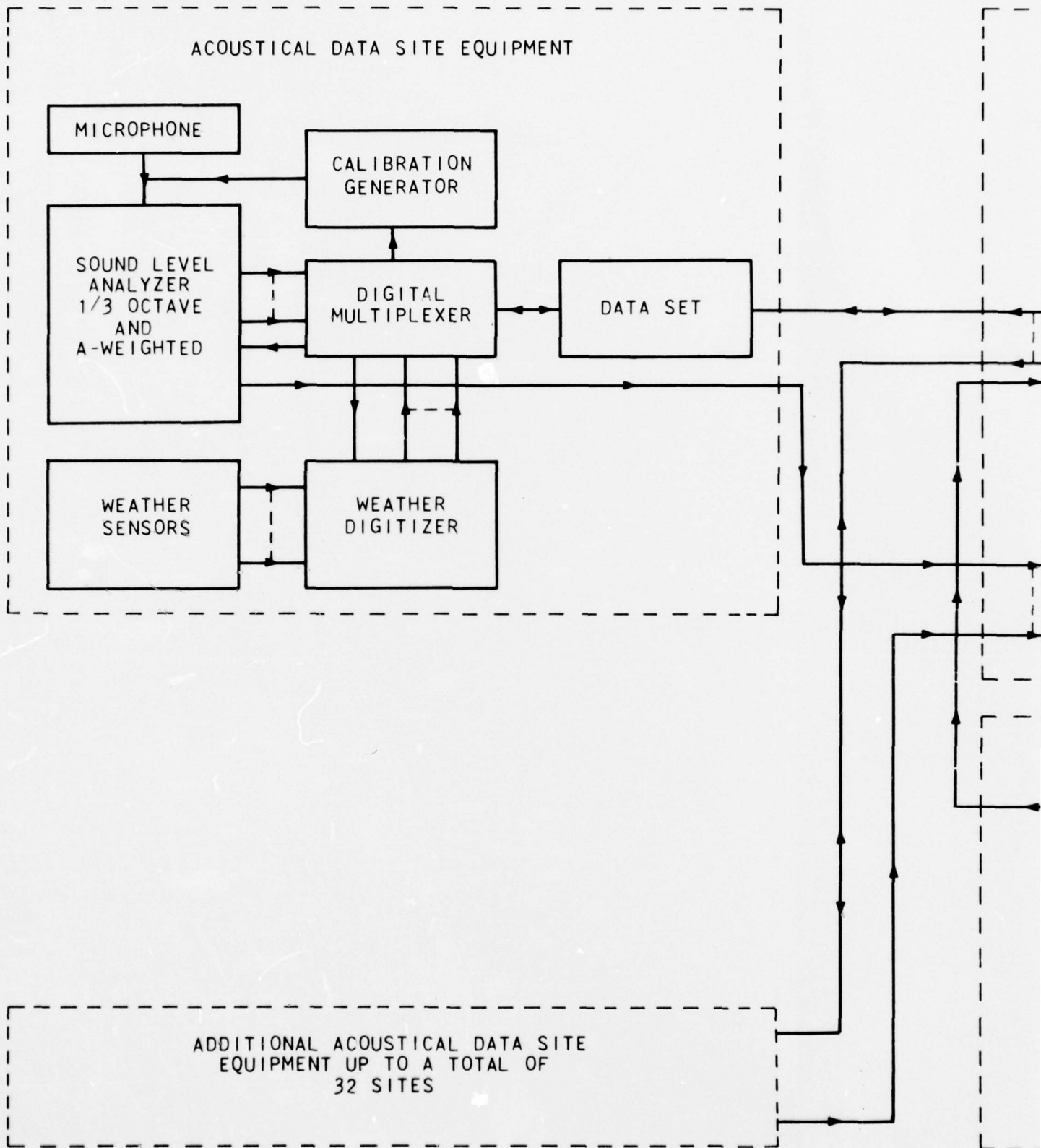
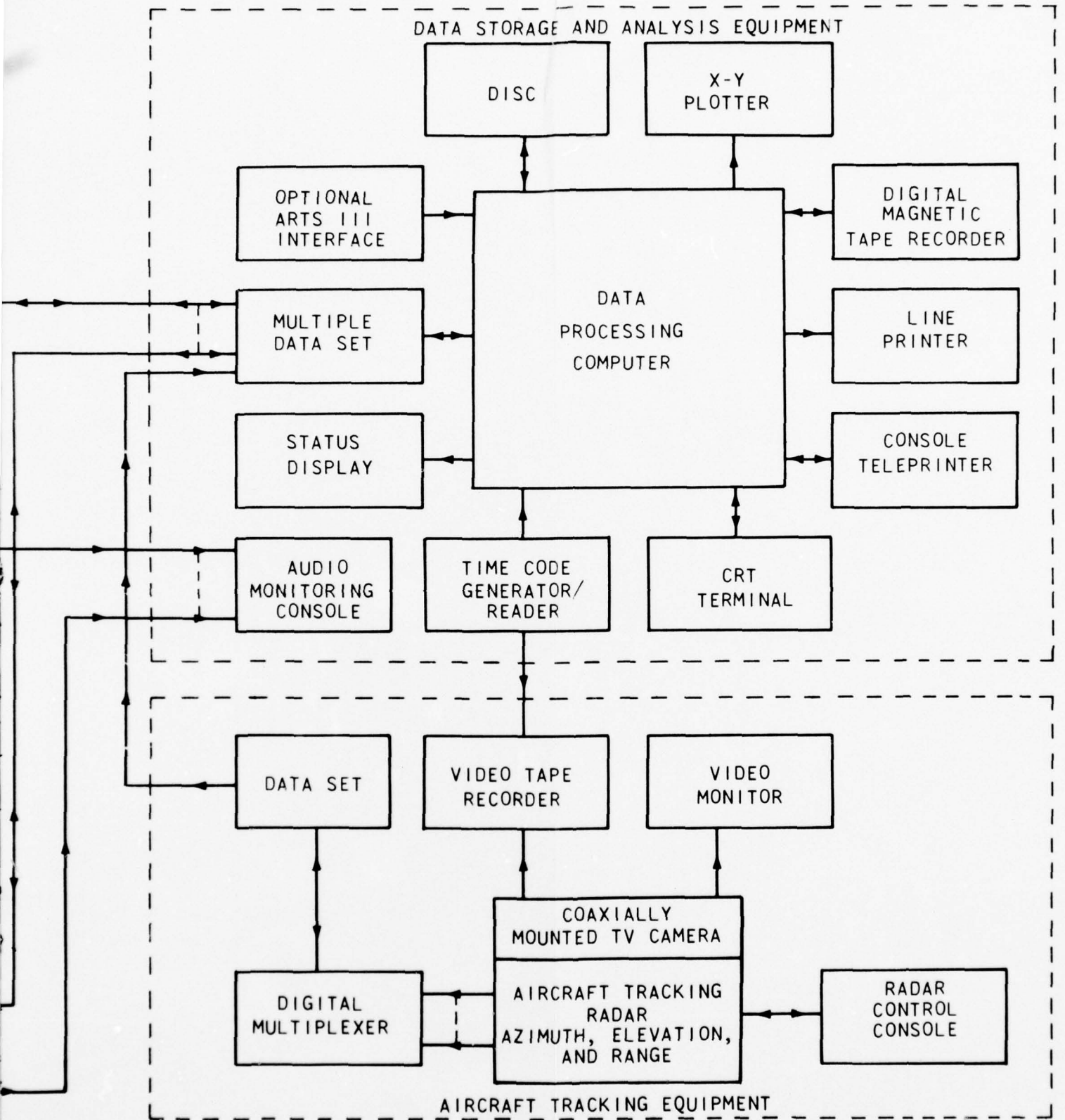

FIGURE 9-1 RESEARCH SYSTEM

PRECEDING PAGE BLANK NOT FILMED



RESEARCH SYSTEM BLOCK DIAGRAM

The tracking system is a 10 GHz radar with a coaxially mounted TV camera. This system is intended to provide three dimensional aircraft location correlated in time with the acoustical measurements. Operating without transponders, its accuracy is not sufficient for certification measurements; however, when properly located relative to the flight path under study (see Section 4.0 for limitations), it can economically provide sufficient accuracy for a broad range of experiments. It can obviously track only one aircraft at a time and is best used with an operator for target acquisition; however, it would be possible to preprogram the auto acquisition three dimensional window in space for special research projects. The TV tracking can be used for target acquisition, enhancement of angular resolution, recording of the aircraft type for later identification, and other purposes. A special digital multiplexer would transmit the three-dimensional coordinates to the central recording and processing site.

The versatile data recording and processing site has a minicomputer with several peripherals as shown in Figure 9.1 for data storage, output display printing and plotting, and system control. All the equipment interactions are controlled by the system software, which allows collection and analysis to be tailored to the specific experiment. Special software routines available on the disc could be combined in various ways for each specific experiment. The operator controls the system through the keyboard on the console teleprinter. Through this console the prepared programs and special programs are combined to meet the specific research objectives. The operator may also input special data such as aircraft identification through this device.

The digital acoustical and weather data are received continuously and simultaneously from the measurement locations. The tracking data are also received continuously. This is a tremendous amount of data and it is impractical to record each

0.5 second sample of data sent from each site continuously; therefore, the software selects data that represent an aircraft flyover and combines these into a data packet for the flyover (event data), which may be stored for later detailed analysis such as EPNL calculations, etc. Also, these data may be processed immediately and simultaneously with detailed data event storage to provide long term parameters (cumulative measures) such as histograms, T_{xx} , time above a threshold, HNL, etc., converting these data to hourly averages and thus greatly reducing the storage requirements.

When convenient, the stored event and cumulative data can be analyzed by statistical techniques, assembled in reports, or used for any other special application.

9.2.1 Acoustical Data Site Equipment

The acoustical data site equipment combines the weather and acoustical data subsystems; however, either subsystem may be used without the other if both types of data are not needed at a site. The site equipment can be assembled from commercially available equipment, except for the digital multiplexer and the weather digitizer, which are straightforward custom interfaces between the acoustical and weather instruments and the data set. The complete instrumentation package, exclusive of microphone and weather sensors, could be housed in a weatherproof box 30 x 24 x 20 inches, mounted on the telephone pole that supports the microphone and weather sensors. The recommended microphone would be a weather protected 1/2 inch diameter microphone with integral windscreen. The acoustical signal is processed by the one-third octave band analyzer. The analyzer provides a digital output for each of the 24 one-third octave band, 0.5 second samples. To provide for continuous data collection with little dead time, the octave band levels are dumped in a very short time to a first-in/first-out

memory in the digital data multiplexer, where they are stored for serial transmission during the sample interval. This allows sampling all the data channels at the same instant in time. The dynamic range of the analyzer is 60 dB and the gain may be adjusted in 10 dB steps under program control from the central site. In parallel with the analyzer, there is an A-weighted channel that detects and digitizes the signal over a 100 dB dynamic range. The digital output of the A-weighted channel is also sampled each 0.5 second and stored in the multiplexer for transmission. The resolution of the acoustical data channels is 0.25 dB minimum and 0.1 dB preferred. A reference calibration level is applied to all the acoustical data by periodic insertion of a pink noise signal into the microphone line. This signal calibrates all the one-third octave bands and the A-weighted channel. The calibration is under program control or can be introduced by the operator with a keyboard command. The calibrate control command is a special character transmitted by the central site computer which is recognized by hardwired logic in the calibrate control circuitry.

The weather sensors are commercial devices available from several manufacturers. These normally have analog outputs, which must be converted to digital form before transmission to the central site.

The parameters to be measured are:

Relative humidity	0 - 100%
Barometric pressure	22 - 32 inches Hg
Wind direction	0 - 360 degrees
Wind speed	2 mph - 100 mph
Temperature	-40 - +120°F

The analog outputs are digitized for transmission to the central site by combining the weather data with the acoustical

data in the digital multiplexer. The data handling requirements are discussed in the following section.

9.2.2 Data Transmission Equipment

The transmission of the acoustical and weather data, both at a rate of one sample each 0.5 second, can be accomplished using 1200 baud transmission equipment. The 1200 baud rate is the lowest standard rate that will transmit all the data. Using a standard baud rate allows the system to interface with the computer using readily available hardware. The data set frequency modulates the serial data stream for transmission. The data transmitted are asynchronous, using a 10 bit code which allows 7 bits of data and start, stop, and parity bits for each "character." (A character means one of these packets of 7 bit of data.) Normally these 7 bits represent the ASCII format of numbers, letters, and symbols.

The one-third octave band analyzer produces three BCD digits of data per channel for each of the 24 channels for each 0.5 second sample. The A-weighted channel also produces three BCD digits per 0.5 second sample. A frame synchronization character, one status character, and a longitudinal check character are added for data integrity. Weather information of three digits are also required. Two digits represent the value and one digit the parameter identifier, e.g., temperature. Therefore, for weather a readout of the value of each parameter will be provided every 5th frame or 2.5 seconds.

By packing the three digit, 12 bit BCD data into two 7 bit characters instead of using three ASCII characters, the data rate may be kept below 1200 baud. This format also retains the capability for a parity bit and frame status bit in each character, thus retaining two of the advantages of the ASCII

format. The data are formatted in 0.5 second frames by the digital multiplexer. Each 0.5 second frame will have 60 characters. The frame is illustrated below.

0.5 Second Frame

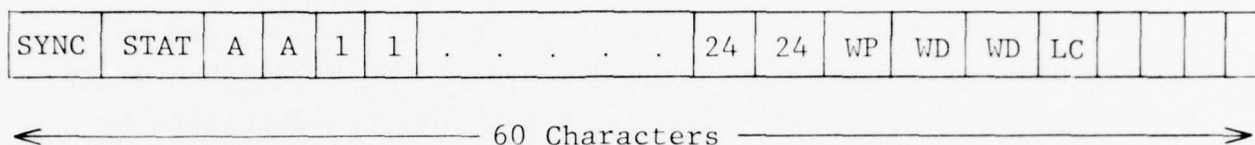

The frame synchronization character (SYNC) is a unique identifier for the beginning of the frame. The second character (STAT) is a status character that indicates the gain setting of the spectrum analyzer, the calibrate on/off for acoustical data, and other special conditions at the acoustical data site. The next two characters represent the A-weighted sound level packet in two 7 bit characters. The next 48 characters represent the band levels for the 24 one-third octave bands, with two characters required for each band level. The next character (WP) indicates which weather parameter is being transmitted and the next two characters (WD) contain the value of the weather parameter being transmitted. The LC character is a longitudinal parity check character. The four remaining character times are held in the marking condition to insure frame synchronization.

9.2.3 Data Storage and Analysis Equipment

The data storage and analysis is performed by a real time minicomputer system. Acceptable computers with compatible peripherals are available from several vendors. Real time inputs are received from the 32 acoustical data sites as well as the tracking radar. These real time inputs are multiplexed into the computer by a communication multiplexer internal to the computer

hardware. Under program control, the computer routes these data to the disc for storage, with or without interim processing. Only data from sites exposed to aircraft noise events are retained in detail. The computer can automatically define probable aircraft events based on level, duration, etc., and automatically store the data at such times. Detailed data at other times are used only for cumulative measures and then discarded. Detailed data would normally be stored on the disc in "event" blocks identified by time of occurrence. The detailed data could then be further processed and new parameters calculated that would reduce the data storage requirements, thereby releasing the raw data storage space.

The one-third octave band spectra and PNLT time histories can be stored in digital format on the disc or magnetic tape. A minimum of 200 time histories, each lasting 30 seconds and consisting of sixty 0.5 second samples of each of the 24 one-third octave band levels, can be stored on a single disc pack along with appropriate header, tracking, and calibration information. A single disc pack could easily store 2000 PNLT time histories. A permanent data bank of the time histories or spectra can be assembled by transferring the data from the disc to the digital magnetic tape periodically.

The several output peripherals - CRT, console teleprinter, line printer, X-Y plotter - provide the versatility of output that makes the research system adaptable to the various experimental goals.

The time code generator provides accurate time to the computer for recording with the input data.

The status display is a map indicating each monitoring location by a pilot lamp which is turned on under computer control

to show activity at that site. Also meters or a CRT display showing the A-weighted sound level at each site are provided for operator convenience.

The pertinent specifications for the data processing subsystem hardware are given in Table 9.1.

9.2.4 Tracking Data Subsystem

The research system tracking data subsystem, shown in Figure 9.1, is composed basically of an X-band radar and a television (TV) camera equipped with a telephoto lens having a remotely controlled zoom capability. Also, in order to measure aircraft position according to FAR Part 36 requirements, tracking of a particular "spot" on the aircraft is required. For this particular purpose, the aircraft must be equipped with a radar transponder which transmits a signal upon radar interrogation.

The tracking system can operate in several modes with corresponding different levels of accuracy. Possible modes of operation are these:

- a. Radar transponder mounted on aircraft.
- b. Radar skin tracking
- c. Radar skin tracking for range determination combined with manual TV tracking for azimuth and elevation information.

The radar transponder method provides the greatest tracking accuracy, since it provides a fixed point on the aircraft as a target. However, special installation of the transponder on the aircraft is required, limiting this application to certification tests and special research projects.

TABLE 9.1
RESEARCH SYSTEM DATA PROCESSING SPECIFICATIONS

NAME	FUNCTION	RELEVANT SPECIFICATIONS
Computer	Computation and control functions	64K words, 16 bit, hardware floating point multiply/divide
Status display	Displays A-weighted sound level in real time and provides digital input from all 16 data channels to computer	70 dB dynamic range
Audio monitor	Switches audio from any site for monitoring	
X-Y plotter	Plots sound level versus position in real time, or other selected outputs after analysis, or other variables	11 inch paper, 0.01 inch steps, 300/steps/second
Time code generator/reader	Provides coordinated time to all parts of system	IRIG B format
Disc	Data and program storage	Moving head disc, one fixed, one removable disc, 1.2 M words each disc
Tape	Permanent data and program storage	9 track, 800 BPI industry compatible
Printer	Data output	300 LPM

TABLE 9.1 - Continued

NAME	FUNCTION	RELEVANT SPECIFICATIONS
Master control	Operator input and control output messages system log	30 CPS keyboard, printer
CRT	Real time data display	_____

Radar skin tracking is available for studies in which transponder installation is not practical. The accuracy is reduced from that achievable with the transponder to the basic radar accuracy, degraded by the uncertainty of the point of reflection. Variations of approximately the size of the aircraft may be encountered. The television system may be used to aid in target acquisition and to enhance azimuth and elevation accuracy, especially when ground reflections interfere with the radar signals.

With proper location, the basic radar system will provide sufficient accuracy to meet FAR Part 36 noise certification requirements. The slant range to the aircraft at the point of maximum noise can be measured sufficiently well that the worst-case correction to the noise level due to position inaccuracy is less than 0.5 dB. This radar system is small enough so that it can be mounted on a central station van containing the required data processing equipment. Hardware is available from at least one vendor.

The recommended unit is an X-band radar, which uses a 4 foot diameter parabolic reflector. Range and angular resolution available are ± 10 meters and ± 1 mil (0.056 degrees), respectively. An alternative radar system to provide greater accuracy would be much larger and more complex, requiring a separate trailer and van. Nominal range and angular resolution available from this type of radar system are ± 5 meters and ± 0.1 mil, respectively. Either radar system normally requires an operator; however, either can be programmed to search and acquire targets automatically. Both radar sets provide digitally encoded elevation and azimuth data for input to the data processing system.

9.2.5 Other Inputs

The proposed hardware configuration shown in Figure 9.1 provides several possibilities for the input of data other than the weather, acoustical, and tracking data normally available in real time. Many experiments may need additional data such as aircraft type identification, air carrier, etc. These special types of data may be input to the system manually through the keyboard, by magnetic tape, or in real time through a spare 1200 baud channel or special computer interface. Several of the possible input arrangements will be described to illustrate how they are accommodated in the system.

Information such as aircraft type, air carrier, etc., may be manually entered into the system through the CRT or console printer keyboard. Sources for such data available to the operator may include:

- a. Visual observations
- b. Tower radio
- c. TV monitor
- d. Daily flight log

The burden of correlating these data with the noise events may be placed on the computer or on the operator. The difficulty of such correlation increases with the frequency of noise events. It is possible for noise events from different flights to occur simultaneously, presenting a difficult correlation problem which probably would require additional information to solve.

Special computer programs are required for either manual or computer correlation of the flight identification data and noise events for any reasonable number of flights. With manual correlation,

each noise event for a measurement location appears on the CRT and the operator labels it with the desired information in real time. This is similar in operation to the noise monitor system in Frankfurt, as described in the Task A report.³ If the computer performs the event correlation, the operator types in the desired data with the time of occurrence and the computer then makes the decision based on the time of the event.

The keyboard is used for several types of inputs such as:

- a. System commands
- b. Program development
- c. Weather observations from an independent weather system
- d. Special conditions of any type

The 9-track magnetic tape machine may be used for input of data records generated on this system or on another system with a compatible tape unit. It may also be used for archival storage of data and for transferring data from this system to another system. For large volumes of real time data, special computer interfaces might be required, or these data could be formatted to be compatible with one of the existing 1200 baud points.

Real time or tape input from the ARTS III system could provide automatic input of the aircraft type and other data as well as coarse tracking data. Access to these data will necessarily be controlled, as any interference with the ARTS III system could present a safety hazard. (See Section 4.2.8 for more detail.)

³Cooper, B. K., and Richard D. Edmiston. Airport Noise Monitoring Systems. Final Task A Report Number FAA-RD-75-216, November 1975.

9.3 Data Processing for the Research System

The data processing system described here is a complete research facility, capable of performing a wide variety of tasks. The nature of this mission requires maximum versatility as well as ease of use. This is the system design philosophy represented here. The design requires the system to be capable of airport noise monitoring (including non-aviation and ambient noises), FAR Part 36 type measurements and moderate data base management. Besides the minimum requirements of Section 7.1, the system is capable of supporting on-going program development and investigative research while concurrently acquiring data in a real time, multiprogramming environment. The data processing system is intentionally over-designed; unneeded features may be left unimplemented, but should not be omitted. The data processing functions shown in Figure 7.1 are implemented entirely in software, in the highest level language possible, to facilitate future system expansion and alterations.

The system described here is based on a dedicated large scale minicomputer, consisting of a central processor, disc and magnetic tape drives, line printer, x-y plotter, CRT terminal, peripheral interface logic, and sufficient memory to run concurrently at least the data acquisition and program development tasks. A typical current generation system might be a 16 bit minicomputer with less than 1.0 microsecond basic instruction time, 64K to 96K (K = 1024) words of main memory with memory allocation hardware, hardware floating point arithmetic instructions, and disc capacity of at least 5 million characters with less than 50 millisecond access time.

The system operates in real time with multiple inputs and outputs. Its software must be capable of supporting the many standard peripherals and special interfaces in an interrupt mode such that no real time data are lost. The software requirements

include a real time operating system application programs for processing for aircraft noise analysis, and utility programs for program development.

For continued hardware and software support, the software operating system should be built using the software operating system of a major minicomputer manufacturer. The data processing hardware should be from the same manufacturer, as should all peripherals within reason. One of the functions of the operating system is to allow the user to prepare special application programs easily, using high level computer languages such as Basic and Fortran. Figure 9.2 shows the division of the research system between vendor and contractor supplied components.

9.3.1 Vendor Supplied Software

Since developing a complete software system for a minicomputer requires many man-years of effort and minicomputer manufacturers have already expended a great deal of effort in developing general purpose software systems, it is reasonable and cost effective to spend a relatively small amount of time in selecting a general purpose software system and applying it to a specific situation. The primary program in a software system is the operating system. It is the responsibility of the operating system to handle all communication between one or more application programs and the outside world, which includes all hardware peripheral devices such as discs, CRT terminals, one-third octave analyzers, printers, and plotters. Other programs in a software system are aids in developing application programs. These aids include such programs as compilers, assemblers, and relocating loaders.

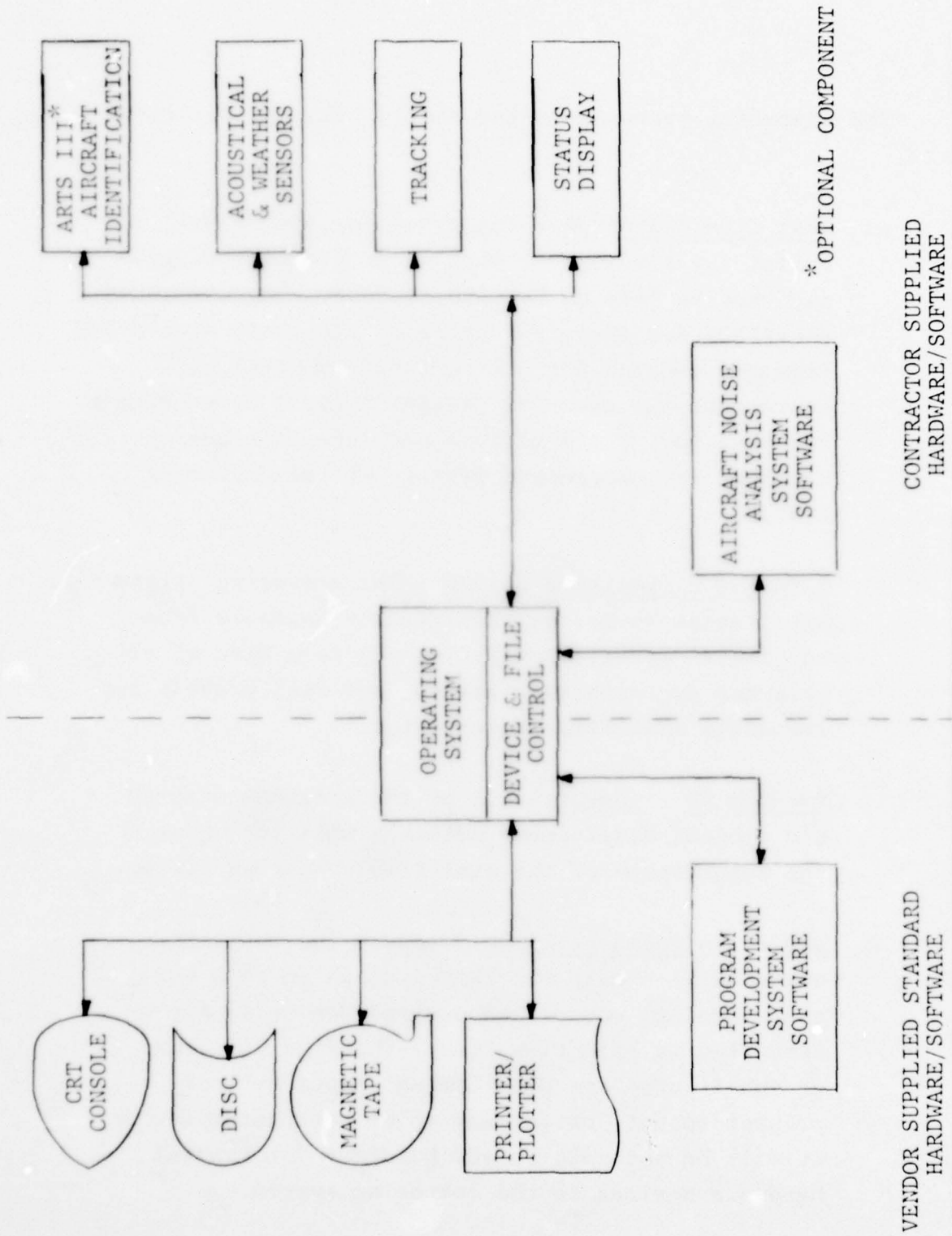

FIGURE 9.2 VENDOR AND CONTRACTOR SUPPLIED COMPONENTS OF THE AIRCRAFT NOISE RESEARCH SYSTEM

The operating system selected should have the following features:

- a. Real Time Operation - The operating system will buffer input/output so that an application program need not be held up by slow devices. There will be provision for executing tasks on the basis of elapsed time and time of day. A multitask monitor will coordinate the needs of several logical tasks within one program. There will be provision for adding handlers of nonstandard devices to the operating system.
- b. Disc Based Operating System - The operating system will reside on and be conveniently loadable from the disc. It will handle loading from disc of all programs and program overlays, and will provide for versatile disc file organization.
- c. Program Development - All of the programs used in the program development sequence will run under the supervision of the real time operating system.
- d. Device-Independent Input/Output - The operating system will handle all input/output in such a way that physical source and destination media may be specified at execution time. The disc files may be substituted for CRT terminal input or line printer output, or for any other peripheral device. It will be possible to add handlers for special hardware devices to the operating system.
- e. Overlays and Chaining - The operating system will load program segments from disc files under application program control. The operating system will

be capable of loading and executing programs under application program control, in addition to operator control.

- f. Multi-Programming - The operating system will support concurrent execution of at least two independent programs. One program, the foreground, may have priority over the second, the background. System hardware resources will be divided between the two programs. Higher levels of multi-programming are acceptable.

The following program development aids will be supplied by the computer manufacturer:

- a. Symbolic Text Editor - The editor will allow easy creation and revision of both symbolic program source code and symbolic data disc files.
- b. Compilers - ALGOL and Fortran compilers will process source code disc files and output assembler source code disc files or relocatable binary disc files.
- c. Assembler - The assembler will process assembler source code disc files and output relocatable disc files.
- d. Relocating Loader - The loader will load several relocatable binary disc files into executable core memory image disc files.

9.3.2 Contractor Supplied Software

The contractor shall be required to provide all specialized software for the measurement system, as well as to integrate that special software into the operating system to

provide a single, comprehensive research tool. In particular, the contractor shall provide working software to implement the following functions, which were described in Section 7.0:

- a. Extend the operating system to allow Data Synchronization, Integration (DSI), and Subsystem Control (SC) over the special hardware subsystems.
- b. A flexible Flyover Data Analysis (FDA) system to perform the actual monitoring and measuring functions.
- c. An Analysis Control (AC) capability to allow an operator to dynamically change the analysis procedure.
- d. A skeletal Data Base Access and Management (DBAM) system.
- e. The above functions shall be implemented in as modular a manner as possible, using Building Blocks which will be available for later system expansion.

With reference to Figure 9.2, the DSI and SC functions reside in the vendor-supplied extension to the operating system labeled DEVICE AND FILE CONTROL. The remaining contractor supplied functions collectively are the AIRCRAFT NOISE ANALYSIS SYSTEM. It is important to note that the RESEARCH SYSTEM must support concurrent NOISE ANALYSIS and PROGRAM DEVELOPMENT capabilities.

9.3.3 Data Synchronization and Integration (DSI)

This function will be an extension to the device control capabilities already existing within the operating system. The contractor-supplied peripheral sensor devices will generate program interrupts as data arrives, just as do the vendor devices. The

DSI will de-multiplex the incoming data as shown schematically in Figure 9.3 for the acoustical and weather sensor subsystem. Referring to the site data transmission format shown in Section 9.2.2, the DSI accepts ASCII bytes from many sites as they arrive in time, and builds a data packet of current conditions at each site for use by FDA. The creation of event data packets will be performed by FDA in this system because of the monitoring requirements.

The DSI also receives tracking information from the tracking radar, and may optionally receive data from ARTS III. In each case DSI accepts input data from the hardware device and stores it in an appropriate table in the CPU memory. The resulting data tables serve as input to the Flyover Data Analysis (FDA) process. The DSI function also will output data to the status display, showing current dBA levels and status conditions at each monitoring site on display meters and lights.

To efficiently perform its function, DSI may reference control information to determine which peripheral devices are currently enabled. Additionally, provision must be made for data stream benchmarking by DSI. It will be possible to copy all incoming data to a disc file, or to accept time synchronized data from a disc file (or other appropriate device, such as magnetic tape) rather than from the normal peripheral devices. The objective of benchmarking is to allow raw data to be saved for later processing in a manner that is as transparent as possible to the whole system. These data may be used to examine the effect of program changes on known data by processing the data first on the standard system, then again on a revised system. Benchmarking capability is generally required on any complex system which is expected to experience frequent change due to system improvements and extensions.

INPUT (FROM DEVICE)

TIME	SITE	BYTE NO.	FUNCTION	VALUE
1	10	0	STAT	5
2	3	1	A1	8
3	4	49	WP	1
.
.
41	3	2	A2	3
42	10	1	A1	7
43	4	50	WD1	1
.
.
86	4	51	WD2	2
87	3	3	BAND 1.1	5
88	10	2	A2	3

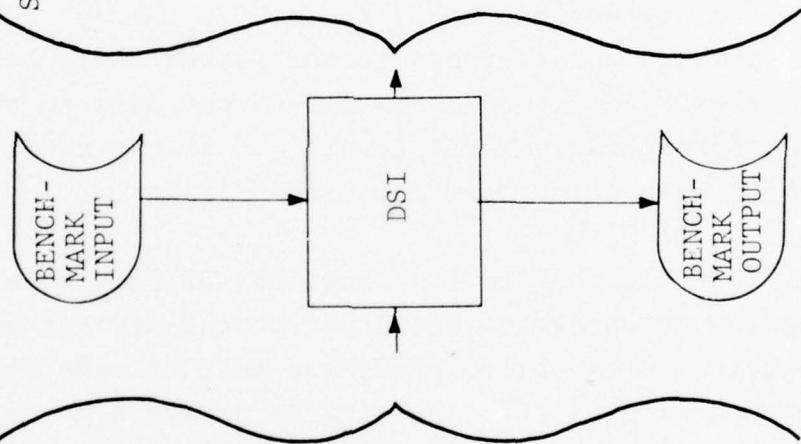

OUTPUT (TO CPU MEMORY)

SITE	GAIN	dB	BAND 1	BAND 2	...	WIND	...
1	—	—	—	—	—	—	—
2	—	—	—	—	—	—	—
3	—	83	5X	—	—	—	—
4	—	—	—	—	—	—	13
.
.
10	5	78	—	—	—	—	—
.
.

FIGURE 9.3 DSI INPUT AND OUTPUT OF ACOUSTICAL AND WEATHER DATA

9.3.4 Subsystem Control (SC)

This function is essentially the opposite of the DSI function: control information is taken from tables in the CPU memory and sent to the special hardware devices, thus allowing for complete automation of the subsystem control function. Table entries are made by either FDA or the Analysis Control (AC) process, and buffered to the hardware by the Subsystem Control function, using the operating system for actual data transfers. The Subsystem Control will also maintain various status indicators which communicate the state of each peripheral to the rest of the system. The precise form of the control function is device dependent, but all controllable functions of any subsystem are supervised by the Subsystem Control process.

Table 9.2 shows hardware functions which are under software control. Any of these functions may be controlled by either the FDA or AC processes. The contractor will have the option of implementing ENABLE/DISABLE functions in hardware (i.e., turning on or off the device), or in software (i.e., allowing continued input from the device, but ignoring the data). CALIBRATION functions must cause a known calibration signal (i.e., pink noise for acoustical sensors) to be injected into the peripheral device, and result in incoming data being flagged as "calibration data" by DSI. Calibration data will be deleted from normal input data.

The tracking system is assumed to be under program control, and unattended. The WINDOW n control defines a window over site n to be searched by the radar to acquire a target. When the ACQUIRE n command is issued, the subsystem control must scan window n until a target is acquired within the specified window, or until the tracking system is issued a RELEASE command.

TABLE 9.2
PERIPHERAL HARDWARE FUNCTIONS UNDER SOFTWARE CONTROL

Subsystem	Function	Result	Site Location
Acoustical	ENABLE RMSn	DSI accepts dBA data	n
	DISABLE RMSn	DSI rejects all data	n
	ENABLE RTAn	DSI accepts dBA and RTA data	n
	DISABLE RTAn	DSI rejects RTA data	n
	CALIBRATE RMSn	DSI accepts calibration data, calibration circuitry enabled	n
Weather	ENABLE RMSn	Also enables weather sensors	n
	DISABLE WXn	DSI rejects weather sensor data	n
Tracking	ENABLE TRAC	DSI accepts radar coordinates (radar activated)	Radar
	DISABLE TRAC	DSI rejects radar data; radar disengaged	Radar
	WINDOW n	Define r, ρ , θ window for site n	n
	ACQUIRE n	Acquire target in window n	n
	RELEASE	Release current target	—
Status Display	FULL	Full scale all meters for calibration	Display
	ZERO	Zero all meters for calibration	Display
	ALARM	Sound alarm for 5 seconds	

The Status Display requires minimal control to allow setting the meter deflection and checking for alarm functioning.

Figure 9.4 is an expanded view of parts of Figure 9.2, and shows the logical information flow between the peripheral devices, DSI and SC, and the ANALYSIS SYSTEM.

9.3.5 Flyover Data Analysis (FDA)

The most critical function in any aircraft noise measurement system is the analysis of aircraft noise events, which is performed by the FDA function. In the research system design, FDA carries the additional burden of noise monitoring for both aircraft and background noise, as well as the responsibility for automated control of the peripheral sensor devices. The design of the FDA for the research system must be modular and flexible, allowing for changes in any of the system functions with minimum impact on the whole system. The FDA performs the following tasks:

- a. Sensor monitoring and event detection
- b. Event processing
- c. Daily report generation

Each of the first two tasks above is complex, and the monitoring task is time critical. The descriptions that follow assume the computer used is a minicomputer with a maximum of 32,768 words of directly addressable user space, hardware memory allocation to allow several users (or tasks) to partition the total CPU memory of 64K to 96K (K = 1024) words between their needs (subject to the 32K maximum for each user), and that some facility exists for two tasks to access the same physical CPU

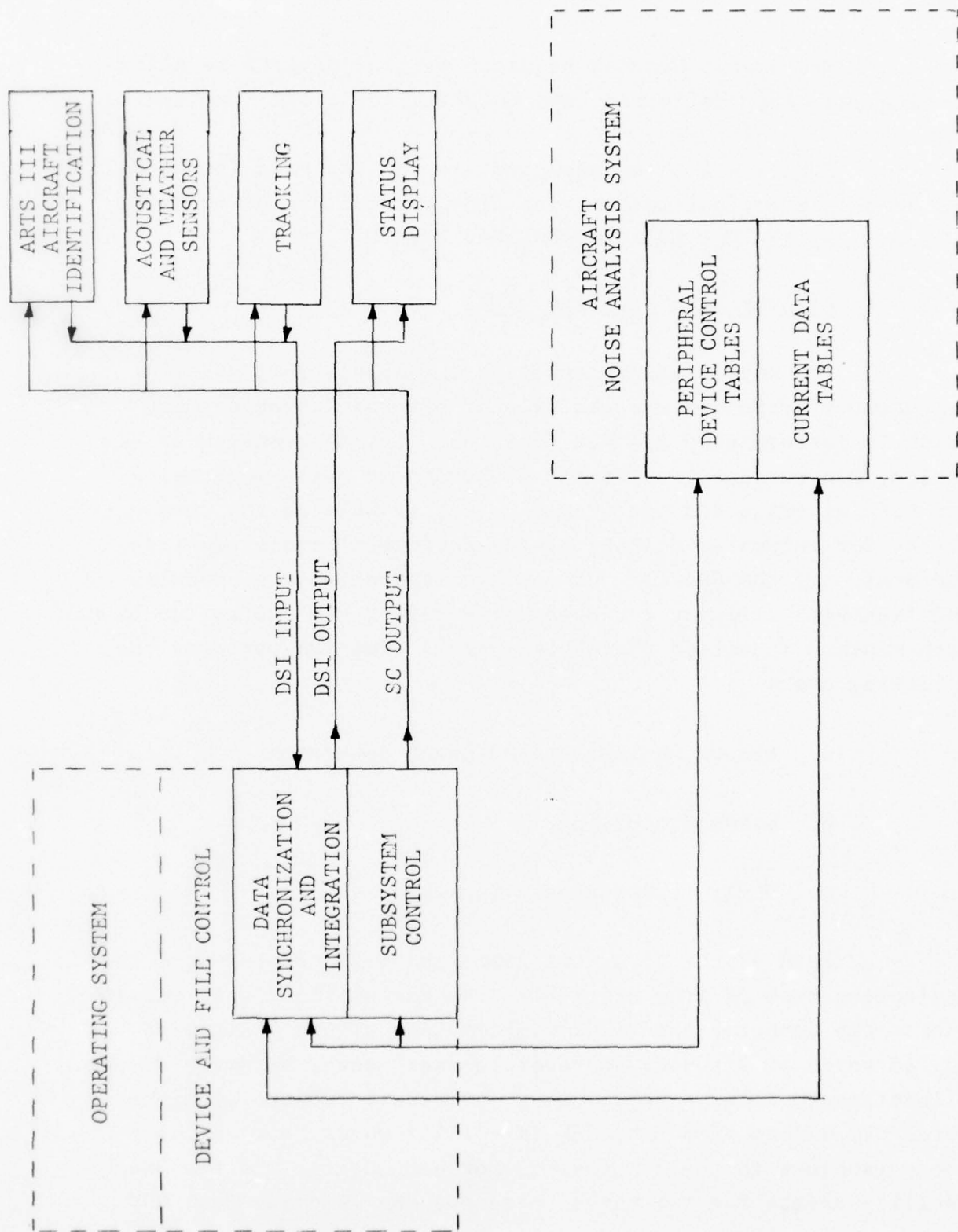

FIGURE 9.4 INFORMATION FLOW BETWEEN SPECIAL PERIPHERAL DEVICES, DSI SC AND THE NOISE ANALYSIS SYSTEM

memory (shared memory). These assumptions characterize current generation large scale minicomputer systems, although precise details of vendor implementations differ. In the following descriptions a "task" will be assumed to be an independently executing program which is allocated its needed memory as a "partition" of the whole physical memory. Figure 9.5 illustrates two tasks and their memory requirements in a simple two way division of 52K total memory into 22K and 32K word partitions.

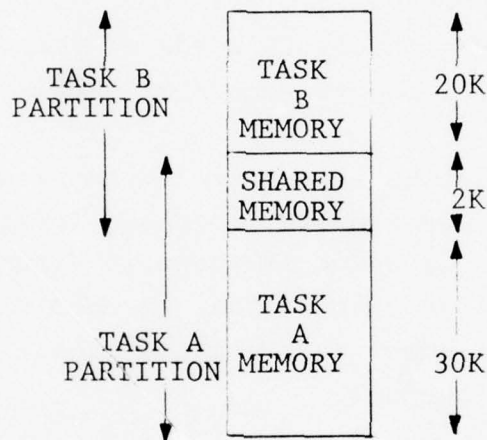

FIGURE 9.5 SIMPLIFIED MEMORY PARTITIONING FOR TWO USER TASKS

Sensor Monitoring and Event Detection Task - The monitoring task accepts current sensor input, computes cumulative noise exposure measures, and detects the beginning of noise events. The cumulative exposure data are stored in tables for later access by the report generating task, while event data are passed on to the event processing task as event data packets.

For each of up to 32 acoustical sensors, A-weighted sound pressure levels are:

1. Energy-integrated to compute HNL and L_{dn} for the day
2. Analyzed for the total time above a selected level, T_{xx} .

These cumulative dBA data for each RMS are stored in cumulative data tables, along with hourly samples of the weather data (averaged over all sites), and data counts indicating the total amount of valid data received from each RMS for the day. These tables will occupy approximately 2K words of shared memory, and will be used by the daily report generator task.

The monitor task will compare incoming dBA data for each RMS with a single event noise threshold level (SENT) for that RMS. A typical noise event is shown in Figure 9.6. When the noise level (NL) first exceeds that threshold event data begins to be collected into an event data packet. These event data include, for every 0.5 second:

1. Noise level in dBA
2. The one-third octave band spectrum if the RTA for the RMS is enabled.
3. The weather sensor data if the weather sensor is enabled.
4. Positional information for any target within the tracking window defined for the RMS, if tracking is enabled.

In addition, the time of the start of the event and the RMS number are entered into the event data packet. These data will be used by the event processing task; they include all available sensory information concerning the event. As soon as the event

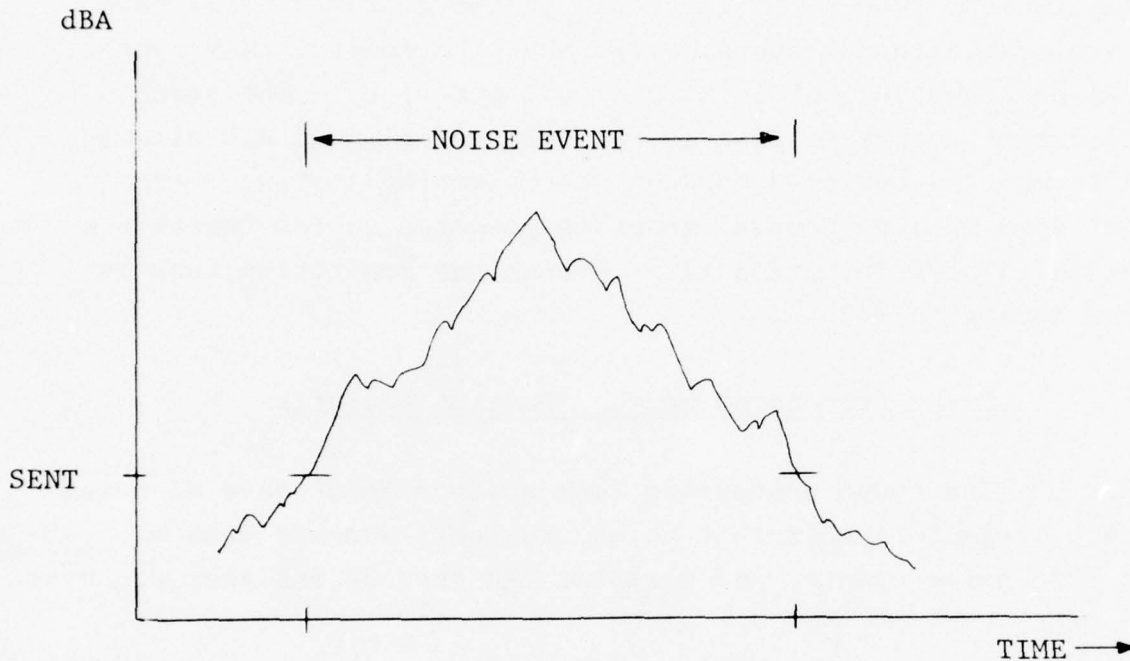

FIGURE 9.6 TIME HISTORY OF A NOISE EVENT

is completed (by the NL dropping to below the SENT), the event packet is written out to a temporary disc file, and the event processing task is notified that the disc data packet is pending disposition. The temporary event data packet table is large enough to store at least three simultaneous 30 second events with all sensors enabled, or about 5K words. The monitor task will turn on optional sensors currently enabled for the monitoring site when the event is detected, and turn off the sensors when the event terminates, using the peripheral device control tables shown in Figure 9.4.

The monitoring task must respond to input data in real time, and so is extremely time critical. If 32 RMS sites are active, the monitoring task has to process each site's data

frame in less than 15 milliseconds on the average. This rate is achievable in the above design, but the monitor task cannot do direct input or output with slow I/O devices. The event data packet output to disc is the only normal mode I/O allowed, and it must be buffered through the operating system. Error conditions may, of course, generate messages to the operator's console. The information flow through the monitoring task is shown in Figure 9.7.

Event Processing and FAR Part 36 Analysis

The event processing task accepts input data on noise events, rejects nonaircraft noise, collects summary data on aircraft noise events, and performs FAR Part 36 analyses whenever required.

Noise events which have both their single event level (SEL) and their effective duration within a range of values specified for the particular RMS will be considered to be aircraft noise events; all other noise events (barking dogs, wind, trucks, etc.) are rejected. The SEL and duration windows are specified in the RMS analysis parameter tables shown in Figure 9.7.

Aircraft noise summary data are the same cumulative measures computed by the monitoring task for the total noise environment at each RMS: HNL, L_{dn} , and T_{xx} . These measures are computed from the noise level time histories of aircraft events, assuming that there are no other noise sources. Calculation of "aircraft only" L_{dn} allows investigation of the incremental impact of aircraft noise. These cumulative data are stored in aircraft noise cumulative data tables for use by the daily report generator.

Each aircraft noise event will be analyzed as completely as possible. If RTA data are available, PNL and PNLT will be

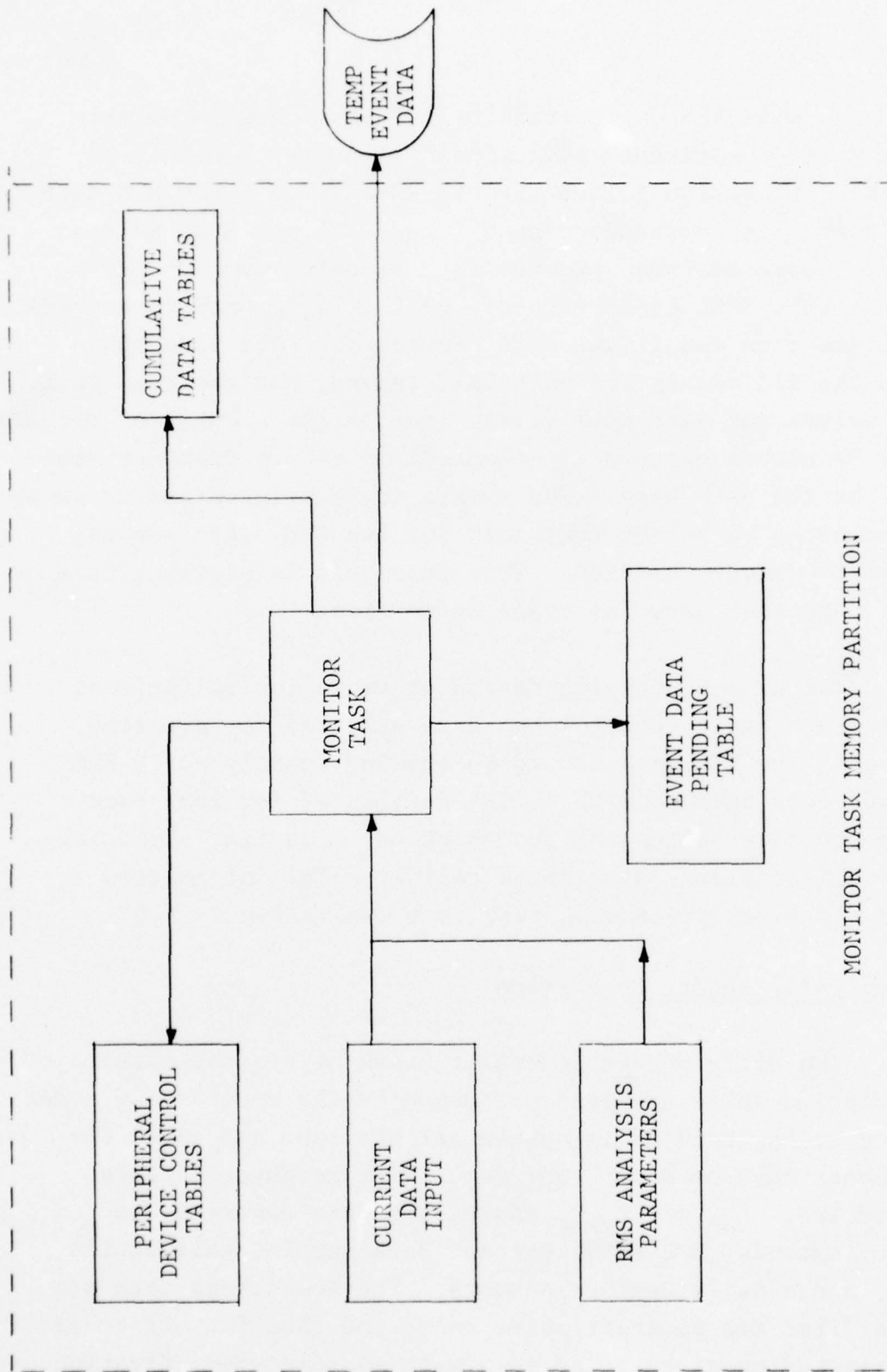

FIGURE 9.7 MONITOR TASK INFORMATION FLOW

computed, as will EPNL. If tracking information is available the EPNL will be corrected to nominal flight track data. If the weather correction switch for the RMS is "on," the RTA data will be corrected to standard conditions, and new EPNL values computed. These analyses produce the following summary data: Time, RMS, SEL, EPNL (uncorrected), EPNL (flight path corrected), and EPNL (weather and flight path corrected). The remaining data are the RTA values for each half second, and the PNL, PNLT, and dBA values for each time frame. Any of the summary or detailed data may be either printed (or plotted) in report form, or saved on disc for the data base. The events to be printed and/or saved may be selected by an SEL threshold for the RMS, with events of lower SEL values rejected. This threshold is distinct from the SENT parameter used for event definition.

The data processing design above relies on rational parameter settings to control the data selected for printing or storage. The RTA data should be enabled in only a few RMS sites, and only summary EPNL or SEL data saved for long term research projects, since collection of detailed time histories will use all available disc space rapidly. The information flow for the event processing task is shown in Figure 9.8.

Daily Report Generation

The daily report generation task prints the results of the cumulative daily analyses performed by the monitor and event processor tasks, does daily system calibration, and saves the daily report data on disc. The cumulative measures reported and saved are: L_{dn} and T_{xx} . Additional data reported, but not saved include: HNL data, percent data sample, calibration results, and a daily weather summary. The acoustical data are recorded first for aircraft noise only, and then for all other noises (excluding aircraft noise), with appropriate indication

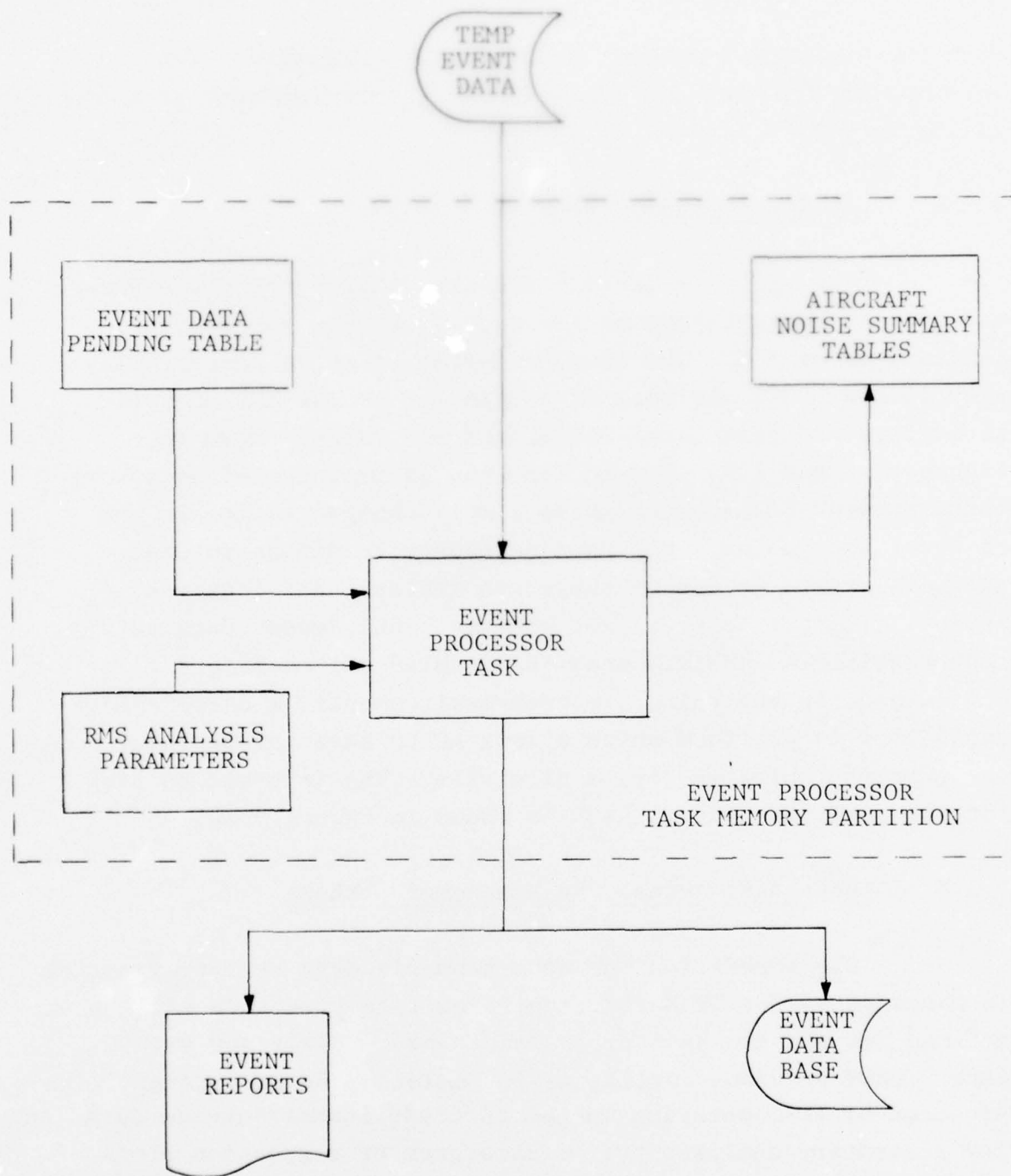

FIGURE 9.8 EVENT PROCESSOR TASK INFORMATION FLOW

when the separation cannot be accurately performed. The information flow for the daily report generation task is shown in Figure 9.9.

9.3.6 Analysis Control (AC)

The analysis control function determines the exact analyses to be performed by the system, within the design limitations of FDA. The implementation of AC is conceptually very simple: all analysis is controlled by the RMS analysis parameters and peripheral device control tables shown in Figures 9.7 and 9.8. The AC function is implemented as a keyboard command interpreter which simply changes values in one of these two tables. All data necessary to direct automatic analysis exists in one of these two tables: RMS location, nominal flight tracks, target windows, SENT, event data save/report switches, RMS/RTA enabled/disabled switches, etc. For convenience in switching research environments, a SAVE/REPLACE capability is provided which allows AC to save (or replace) the current tables in (by) a disc file. The information flow for the analysis control task is shown in Figure 9.10.

9.3.7 Data Base Access and Management (DBAM)

The foundation for an extendable data retrieval system is provided by the DBAM function. The file structure will be defined for the two data types maintained: daily and event data. DBAM provides facilities for deleting or correcting files produced by FDA, entering manual aircraft identification data, and for elementary analyses by: scattergram or regression plots of data, such as daily L_{dn} for aircraft by day or by month; creation of cumulative summary reports for any specified period of time; and file access for special data analysis. The contractor will insure that the skeletal DBAM provided is easily extendable for other specific research needs. The information flow for DBAM is shown in Figure 9.11.

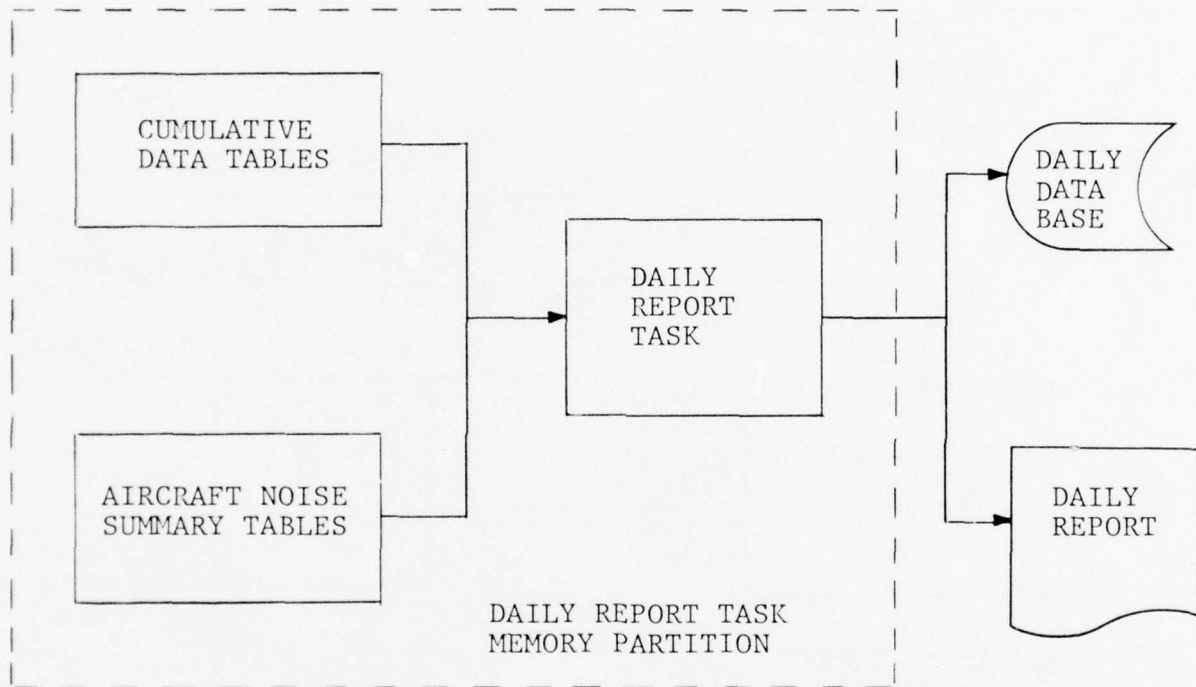

FIGURE 9.9 DAILY REPORT TASK INFORMATION FLOW

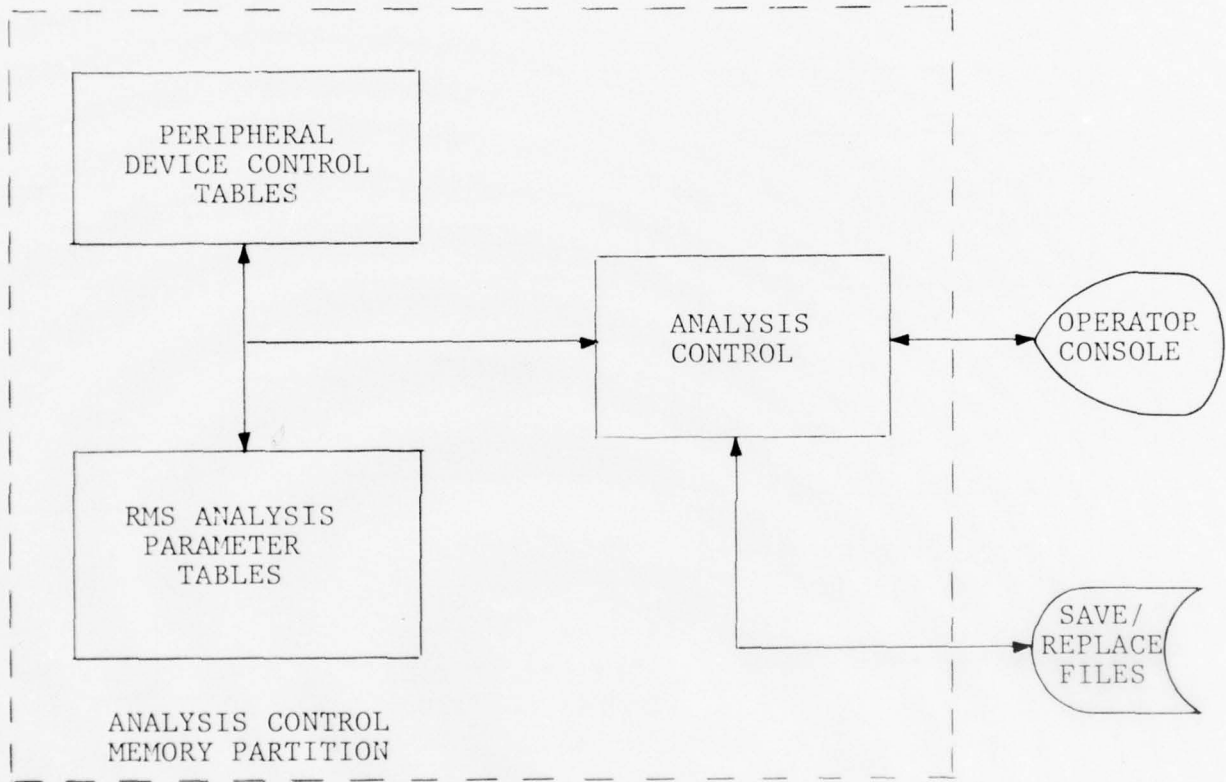

FIGURE 9.10 ANALYSIS CONTROL INFORMATION FLOW

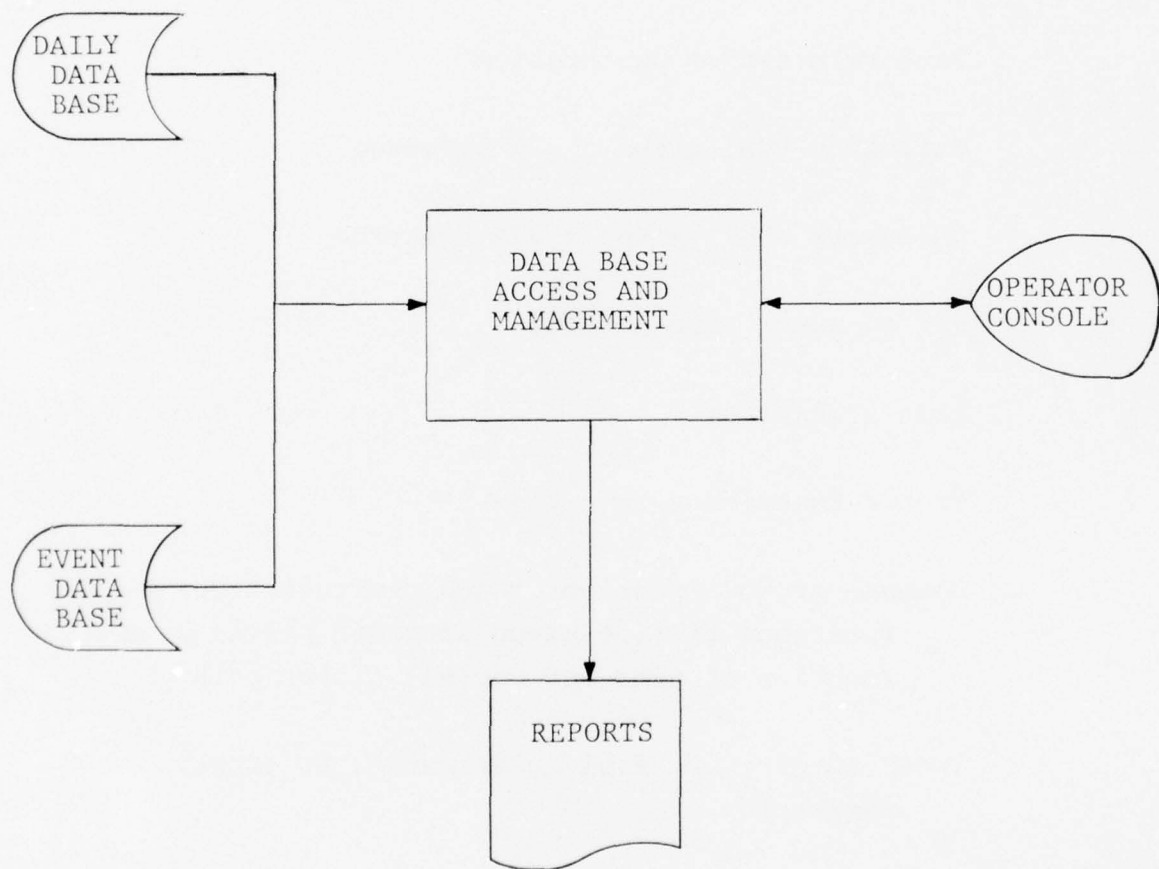

FIGURE 9.11 DATA BASE ACCESS AND MANAGEMENT INFORMATION FLOW

9.3.8 Building Blocks

Throughout all software implementation it is desirable to develop as many independent modules (i.e., subroutines) as possible to facilitate future development. Typical modules would:

Perform a system calibration

Calculate PNL, given a RTA spectrum

Calculate PNLT, given a RTA spectrum

Get an event time history

Plot a spectrum

Plot a function versus time

Compute ground track error and altitude error as functions of time given aircraft position as a function of time and nominal flight path

Track an aircraft from outer marker to runway threshold

This set of building blocks aids a programmer or operator in responding quickly to one-of-a-kind problems.

9.4 Summary Specifications and Costs

The most pertinent performance characteristics and specifications of the recommended research noise measurement system are summarized in this section. Also a range of anticipated costs for such a system is given, including subsystem cost breakdown. To the experienced system designer, most of the features, listed and unlisted, can be deduced from the system block diagram of Figure 9.1. The features listed are those that are considered important in fulfilling research objectives.

9.4.1 Performance Characteristics

Real time data inputs:

a. Acoustical (each site):

A-weighted acoustical data sampled every 0.5 second

A-weighted dynamic range, 100 dB

A-weighted resolution 0.25 dB minimum, 0.1 dB preferred

24 one-third octave bands beginning at 50 Hz center frequency and ending at 10 kHz center frequency - each band level sampled every 0.5 second, one-third octave band level dynamic range, 60 dB, with range changing to cover 100 dB total range

b. Weather:

Any or all parameters may be sampled at each acoustical measurement site or independent weather measurement sites. Each parameter is sampled every 2.5 seconds.

Relative humidity	0 - 100%
Barometric pressure	22 - 32 inches Hg
Wind direction	0 - 360 degrees
Wind speed	2 mph - 100 mph
Temperature	-40 - +120°F

c. Tracking:

Single target tracking by radar

Range \pm 30 feet

Azimuth \pm 1 mil

Elevation \pm 1 mil

Note: accuracy limited by size of aircraft in skin tracking mode.

System performance:

- a. Simultaneous monitoring of acoustical and weather parameters from 32 sites.
- b. One-third octave band level data from up to 6 sites stored simultaneously.
- c. Real time EPNL calculations for 3 sites simultaneously.
- d. Three dimensional position, time correlated with acoustic measurements, provided by a 10 GHz radar.
- e. Software provided for data storage and analysis.
- f. Optical real time ARTS III interface for aircraft identification (type, air carrier, etc.) and coarse tracking.

- g. Manual aircraft identification input through keyboard such as aircraft type, air carrier, pilot, and destination.
- h. Noise event and cumulative noise measure processing.
- i. Noise events correlated with aircraft position and aircraft identification.

Data transmission:

Digital frequency shift keying (FSK) data transmission of acoustical and weather data on the same line from the acoustical measuring sites to the central processing site.

Baud rate: 1200

Telephone line: voice grade full duplex (4 wire)
per Bell System Specification 3002

Data set: Bell System 202 or equivalent

Software:

Operating systems
Application programs

Data processing hardware:

Printing	Single event, cumulative data reports, and tracking data
Plotting	Acoustical and positional data
Recording	Noise, weather, tracking data for reference or further processing

9.4.2 Costs

The cost of a complete research system installed with sixteen acoustical monitoring and weather measurement sites is estimated to be between \$697K and \$1.456M. Although only sixteen units are installed initially the system should accept data from 32 sites. These costs will be influenced by variables such as maintenance requirements, warranty, training, installation details, and telephone line rentals. A breakdown of the system costs is shown in Table 9.3.

There are many variations of system complexity that will affect the costs and which should be considered when system procurement specifications are prepared. The complexity should be adjusted to reflect the relative importance of the experimental objectives at the time of procurement. All five weather parameters may not be needed at all measurement sites or weather measurements may be needed at sites where no acoustical measurements are needed. The A-weighted sound level may be sufficient at some sites, thereby eliminating the need for an expensive one-third octave band analyzer at every site. The cost of the tracking system is also a significant portion of this system. The most cost effective tracking system is highly dependent upon the specific research objective as discussed previously and should be selected to meet the specific goals as defined in the final procurement specifications for a research system.

The estimated hardware costs for a typical research system using quality current production equipment is shown in Table 9.4. Cost for the remote data collection site equipment is shown on a per site basis. The equipment breakdown corresponds to the research system block diagram, Figure 9.1.

TABLE 9.3

RESEARCH SYSTEM COSTS FOR SYSTEM WITH
SIXTEEN MONITOR SITES

System Component	Cost Range	
Acoustical site based on 16 sites	\$224K	\$448K
Weather site	48K	128K
Software	75K	250K
Tracking	275K	450K
Data storage and analysis	75K	180K
	\$697K	\$1.456M

TABLE 9.4

TYPICAL RESEARCH SYSTEM EQUIPMENT COSTS

System Component	Cost
<u>Tracking System</u>	
TV cameras and recorders	\$ 28 000
Tracking radar	320 000
Digital multiplexer and data set	7 000
	<u>\$355 000</u>
<u>Acoustical Data Collection Equipment</u>	
One-third octave band analyzer	\$ 9 500
Data set and multiplexer (each site)	6 000
	<u>\$ 15 500</u>
<u>Weather Data Collection Equipment</u>	
Sensors	\$ 2 500
Multiplexer	1 200
	<u>\$ 3 700</u>
<u>Data Analysis Equipment</u>	
Computer	\$ 51 100
Disc	11 900
Digital track tape	9 900
Console printer	3 300
Line printer	8 500
Plotter	5 000
CRT	4 450
Time code generator	3 500
Data set	6 400
Status display	5 000
Audio monitor	2 100
	<u>\$111 150</u>

10.0 SUMMARY OF RESULTS

The work performed on this project was divided into two distinct tasks, each of which resulted in a separate report. The present report documents the work done on Task B, which is the preliminary design of an aircraft noise measurement system for certification and research. As a minimum, such a system must provide a sufficient data collection capability to meet the requirements of Federal Aviation Regulation Part 36. This requires one-third octave band analysis of the acoustical data as well as positional tracking adequate to apply the slant range correction of FAR Part 36. This report discusses available systems hardware and techniques for performing these detailed measurements. The Task A report documents the currently used techniques and equipment for aircraft noise monitoring. In these reports aircraft noise monitoring means a continuous assessment of aircraft noise at several locations in the vicinity of the airport, performed on a long-term basis with a permanent system. This is usually done in terms of single number, weighted sound level, sampled once or twice per second, in contrast to the detailed spectral data required for certification and research measurements.

10.1 Task A Results

Ten monitoring systems in the United States and Europe were visited to collect first-hand information on system operation and hardware. Each of these systems is described in detail in the Task A report. The information provided will be of special interest to airport operators or others planning to acquire a noise monitoring system. These systems fall into two distinct categories: (1) event-oriented systems that collect and retain one or more measures of each noise event, (2) exposure-oriented

systems that measure cumulative noise exposure on a daily and/or hourly basis. All systems transmit acoustical level data at least once per second to a central monitoring location; therefore, the capability exists to produce both event data and cumulative exposure data, given suitable software. In practice, most systems produce some data of each type. An event-oriented system requires a large amount of manpower to identify all noise events as to flight number, carrier, etc., as this is a manual process. This can be done by real time entry into a log or computer terminal or, for a limited number of flights, it can be done after the fact using an operations log supplied by others.

In an exposure-oriented system, typified by most recent United States systems, many of which were designed to meet the requirements of the California law, the cumulative exposure level is the primary measure. However, a limited number of particularly noisy events can be logged on system printouts and provisions are usually made to correlate these events with flight numbers by listening to a playback of the tower radio channels. The radio communications recording has a time code which can be correlated with the time of the event.

Monitoring system hardware consists of remote and central station equipment. The former includes a microphone mounted on a pole in the community, with associated signal processing equipment installed in a weatherproof enclosure near the base of the pole. The signal processing equipment converts the audio signal from the microphone to a sound level and transmits this level, as a digital or frequency encoded signal, on a telephone line to the central monitoring site. The most recent system designs in Europe and the United States use digital data transmission. A minicomputer at the central site collects the data and performs the necessary calculations and other functions to generate reports of events or cumulative exposure level on a

teleprinter. United States systems tend to cover a wider dynamic range than the European systems. Also, United States systems typically use hydrophone type microphones, while European systems tend to use condenser microphones.

Each of the systems studied fully met the requirements for which it was purchased. Each system tended to be tailored in both hardware and software to meet specific noise abatement program needs at the particular airport. On the basis of the system usage observed at major airports, it is expected that future systems will be closely integrated with the respective airport noise abatement programs and will provide the following special outputs:

- a. Single event excess reports
- b. Airport noise reports
- c. Community noise reports
- d. Air carrier performance reports

10.2 Task B Results

Task B, as reported in this volume, is the preliminary design of an aircraft noise measurement system. This design is intentionally general in order to illustrate the range of performance that is achievable using existing technology. A complete aircraft noise measurement system consists of subsystems for:

- a. Acoustical data collection
- b. Aircraft positional tracking

- c. Weather data collection
- d. Aircraft identification and operating parameter recording
- e. Data processing and recording

Several approaches to the design of each of these subsystems are discussed in the separate subsystem chapters. Each technique has certain advantages and disadvantages which must be weighed in the final engineering design of a system, taking into account specific measurement objectives as well as test site and data volume requirements. Measurement objectives could vary from occasional performance of FAR Part 36 certification measurements to continuing research on the effectiveness of noise abatement procedures in all weather conditions for all aircraft using a major airport. The subsystem concepts discussed include equipment and techniques to cover this broad range of objectives.

Two prototypical complete measurement systems are described, each applicable to a certain range of measurement objectives. One example is a certification noise measurement system which is transportable and requires several operating personnel; this is particularly suited to making a limited number of measurements in good weather, as required for certification to FAR Part 36. This system employs analog tape recording of the acoustical data and precise laser tracking of aircraft position.

The second measurement system example is a completely automatic permanently installed system. While this system is capable of FAR Part 36 measurements, it is optimized for collection

of large volumes of data and is designed to serve many research objectives. Although automatic in operation, it would have many preprogrammed functions and would support a staff of research scientists and computer specialists in achieving its maximum utility.

APPENDIX A

CURRENT FAR PART 36
AND PROPOSED RULES CHANGES

(c) *Variable-pitch propellers.* Compliance with this paragraph must be shown for a propeller of the greatest diameter for which certification is requested. Each variable-pitch propeller (a propeller the pitch setting of which can be changed by the flight crew or by automatic means while the propeller is rotating) must be subjected to one of the following tests:

(1) A 100-hour test on an engine with the same power and rotational speed characteristics as the engine or engines with which the propeller is to be used. Each test must be made at the maximum continuous rotational speed and power rating of the propeller. If a takeoff rating greater than the maximum continuous rating is to be established, and additional 10-hour block test must be made at the maximum power and rotational speed for the takeoff rating.

(2) Operation of the propeller throughout the engine endurance tests prescribed in Part 33 of this subchapter.

[Doc. No. 2095, 29 FR 7458, June 10, 1964, as amended by Amdt. 35-2, 32 FR 3737, Mar. 4, 1967]

§ 35.41 **Functional test.**

(a) Each variable-pitch propeller must be subjected to the applicable functional tests of this section. The same propeller used in the endurance test must be used in the functional tests and must be driven by an engine on a test stand or on an aircraft.

(b) *Manually controllable propellers.* 500 complete cycles of control must be made throughout the pitch and rotational speed ranges.

(c) *Automatically controllable propellers.* 1,500 complete cycles of control must be made throughout the pitch and rotational speed ranges.

(d) *Feathering propellers.* 50 cycles of feathering operation must be made.

(e) *Reversible-pitch propellers.* 200 complete cycles of control must be made from the lowest normal pitch to the maximum reverse pitch.

§ 35.43 **Special tests.**

The Administrator may require any additional tests he finds necessary to substantiate the use of any unconventional features of design, material, or construction.

§ 35.45 **Teardown inspection.**

(a) After completing the tests prescribed in this subpart, the propeller

must be completely disassembled and a detailed inspection must be made of the propeller parts for fatigue, wear, and distortion.

(b) After the inspection the applicant must make any changes to the design or any additional tests that the Administrator finds necessary to establish the airworthiness of the propeller.

§ 35.47 **Propeller adjustments and parts replacements.**

The applicant may service and make minor repairs to the propeller during the tests. If major repairs or replacement of parts are found necessary during the tests or in the teardown inspection, the parts in question must be subjected to any additional tests the Administrator finds necessary.

PART 36—NOISE STANDARDS: AIRCRAFT TYPE AND AIRWORTHINESS CERTIFICATION

Subpart A—General

- Sec. 36.1 Applicability.
- 36.2 *Special retroactive requirements.*
- 36.3 Compatibility with airworthiness requirements.
- 36.5 Limitation of part.
- 36.7 Acoustical change.

Subpart B—Subsonic Transport Category Large Airplanes and Turbojet Powered Airplanes

- 36.101 Noise measurement.
- 36.103 Noise evaluation.

Subpart C—Noise Limits

- 36.201 Noise limits.

Subpart D [Reserved]

Subpart E [Reserved]

Subpart F—Propeller Driven Small Airplanes

- 36.501 Noise limits.

Subpart G—Operating Limitations and Information

- 36.1501 Procedures and other information.
- 36.1581 Manuals, markings, and placards.

Appendix A—Aircraft noise measurement under § 36.101

Appendix B—Aircraft noise evaluation under § 36.103

Appendix C—Noise levels for subsonic transport category and turbojet powered airplanes under § 36.201

Appendix D—E [Reserved]

Appendix F—Noise requirements for propeller-driven small airplanes

AUTHORITY: The provisions of this Part 36 issued under sec. 313(a), 601, 602, and 611.

AD-A042 798

TRACOR SCIENCES AND SYSTEMS AUSTIN TEX

F/G 1/3

PRELIMINARY DESIGN OF AN AIRCRAFT NOISE MEASUREMENT SYSTEM FOR --ETC(U)

JAN 77 B K COOPER

DOT-FATGWA-3900

UNCLASSIFIED

TRACOR-T75-AU-9531U

FAA-RD-75-217

NL

3 OF 3

AD
A042798



federal register

END

DATE
FILMED

9 -77

DDC



49 U.S.C. 1354, 1421, 1423, and 1431; sec. 6(c) (40 U.S.C. 1655(c)), unless otherwise noted.

SOURCE: The provisions of this Part 36 contained in Docket No. 9337, 34 F.R. 18364, Nov. 18, 1969, unless otherwise noted.

Subpart A—General

§ 36.1 Applicability.

(a) This Part prescribes noise standards for the issue of the following certificates:

(1) Type certificates, and changes to those certificates, and standard airworthiness certificates, for subsonic transport category large airplanes, and for subsonic turbojet powered airplanes regardless of category.

(2) Type certificates and changes to those certificates, and standard airworthiness certificates and restricted category airworthiness certificates, for propeller driven small airplanes, except airplanes that are designed for "agricultural aircraft operations" as defined in § 137.3 of this chapter, as effective on January 1, 1966, or for dispensing fire fighting materials.

(b) Each person who applies under Part 21 of this chapter for a type or airworthiness certificate specified in this Part must show compliance with the applicable requirements of this Part, in addition to the applicable airworthiness requirements of this chapter.

(c) Each person who applies under Part 21 of this chapter for approval of an acoustical change described in § 21.93(b) of this chapter must show that the airplane complies with § 36.7 of this Part in addition to the applicable airworthiness requirements of this chapter.

(d) Each person who applies for the original issue of a standard airworthiness certificate for a subsonic transport category large airplane or for a turbojet powered airplane under § 21.183, must, regardless of date of application, show compliance with the applicable provisions of this Part (including Appendix C), as effective on December 1, 1969, for airplanes that have not had any flight time before—

(1) December 1, 1973, for airplanes with maximum weights greater than 75,000 lbs., except for airplanes that are powered by Pratt and Whitney Turbo Wasp JT3D series engines;

(2) December 31, 1974, for airplanes with maximum weights greater than 75,000 lbs. and that are powered by Pratt

and Whitney Turbo Wasp JT3D series engines; and

(3) December 31, 1974, for airplanes with maximum weights of 75,000 lbs. and less.

(e) Each person who applies for the original issue of a standard airworthiness certificate under § 21.183, or for the original issue of a restricted category airworthiness certificate under § 21.185, for a propeller driven small airplane that has not had any flight time before January 1, 1980, must show compliance with the applicable provisions of this Part.

(Title I of the National Environmental Policy Act of 1969 (42 U.S.C. 4321 et seq.); and Executive Order 11514, March 5, 1970.) [Doc. No. 13243, Amdt. 36-4, 40 FR 1034, Jan. 6, 1975]

§ 36.2 Special retroactive requirements.

(a) Notwithstanding § 21.17 of this chapter, and irrespective of the date of application, each applicant covered by § 36.201(b) and (c)(1), and sec. C36.5 of Appendix C to this part who applies for a new type certificate, must show compliance with the applicable provisions of this part.

(b) Notwithstanding § 21.101(a) of this chapter, each person who applies for an acoustical change to a type design specified in § 21.93(b) of this chapter must show compliance with the applicable provisions of this part.

[Docket No. 9337, 34 F.R. 18364, Nov. 18, 1969; 34 F.R. 19026, Nov. 29, 1969]

§ 36.3 Compatibility with airworthiness requirements.

It must be shown that the airplane meets the airworthiness regulations constituting the type certification basis of the airplane under all conditions in which compliance with this part is shown, and that all procedures used in complying with this part, and all procedures and information for the flight crew developed under this part, are consistent with the airworthiness regulations constituting the type certification basis of the airplane.

§ 36.5 Limitation of part.

Pursuant to 49 U.S.C. 1431(b)(4), the noise levels in this part have been determined to be as low as is economically reasonable, technologically practicable, and appropriate to the type of aircraft to which they apply. No determination is

made, under this part, that these noise levels are or should be acceptable or unacceptable for operation at, into, or out of, any airport.

§ 36.7 Acoustical change.

(a) *Subsonic transport category large airplanes and turbojet powered airplanes.* For subsonic transport category large airplanes and turbojet powered airplanes for which an acoustical change approval is applied for under § 21.93(b) of this chapter, the following apply:

(1) If the airplane can achieve the noise limits prescribed in Appendix C of this Part, or lower noise levels, prior to the change in type design, it may not exceed the noise limits prescribed in Appendix C after the change in type design.

(2) If the airplane cannot achieve the noise limits prescribed in Appendix C of this Part prior to the change in type design, it may not, after the change in type design, exceed the noise levels created prior to the change in type design, measured and evaluated as prescribed in Appendices A and B of this Part. For airplanes covered by this subparagraph for which application for acoustical change approval is made after September 17, 1971, the following must be complied with, in addition to the applicable provisions of Appendices A and B of this Part, in determining the takeoff and sideline noise levels of the airplane:

(i) There may be no reduction in power or thrust below the highest airworthiness approved power or thrust, during the tests conducted before and after the change in type design.

(ii) For the noise levels measured and evaluated before and after the change in type design, the test day speeds and the acoustic day reference speed must be the minimum approved value V_2+10 knots, or the all-engine-operating speed at 35 feet (for turbine engine powered airplanes), or 50 feet (for reciprocating engine powered airplanes), whichever speed is greater as determined under the regulations constituting the type certification basis of the airplane. The tests must be conducted at the test day speeds ± 3 knots. Noise values measured at the test day speeds must be corrected to the acoustic day reference speed.

(iii) During the tests conducted before the change in type design, the quietest airworthiness approved configuration available for the highest approved take-off weight must be used.

(b) *Propeller driven small airplanes.* For propeller driven small airplanes in the normal, utility, acrobatic, transport, and restricted categories for which an acoustical change approval is applied for under § 21.93(b) of this chapter after January 1, 1975, the following apply:

(1) If the airplane was type certificated under Appendix F of this Part prior to the change in type design, it may not, after the change in type design, exceed the noise limit that was applied to that approval.

(2) If the airplane was not type certificated under Appendix F but can achieve the noise limits prescribed in § F36.301(b) of that Appendix prior to the change in type design, it may not exceed those limits, measured and corrected as prescribed in Appendix F, after the change in type design.

(3) If the airplane cannot achieve the noise limits prescribed in § F36.301(b) of Appendix F prior to the change in type design, it may not, after the change in type design, exceed the noise levels created prior to the change in type design, measured and corrected as prescribed in Appendix F.

(Title I of the National Environmental Policy Act of 1969 (42 U.S.C. 4321 et seq.); and Executive Order 11514, March 5, 1970.) [Doc. No. 13243, Amdt. 36-4, 40 FR 1034, Jan. 6, 1975; 40 FR 2797, Jan. 16, 1975; 40 FR 6347, Feb. 11, 1975]

Subpart B—Subsonic Transport Category Large Airplanes and Turbojet Powered Airplanes

§ 36.101 Noise measurement.

The noise generated by the airplane must be measured under Appendix A of this part or under an approved equivalent procedure.

§ 36.103 Noise evaluation.

Noise measurement information obtained under § 36.101 must be evaluated under Appendix B of this part or under an approved equivalent procedure.

Subpart C—Noise Limits

§ 36.201 Noise limits.

(a) Compliance with this section must be shown with noise levels measured and evaluated as prescribed in Subpart B of this part, and demonstrated at the measuring points prescribed in Appendix C of this part.

(b) For airplanes that have turbojet engines with bypass ratios of 2 or more and for which—

(1) Application was made before January 1, 1967, it must be shown that the noise levels of the airplane are no greater than those prescribed in Appendix C of this part, or are reduced to the lowest levels that are economically reasonable, technologically practicable, and appropriate to the particular type design; and

(2) Application was or is made on or after January 1, 1967, it must be shown that the noise levels of the airplane are no greater than those prescribed in Appendix C of this part.

(c) For airplanes that do not have turbojet engines with bypass ratios of 2 or more and for which—

(1) Application was made before December 1, 1969, it must be shown that the lowest noise levels, reasonably obtainable through the use of procedures and information developed for the flight crew under § 36.1501 are determined; and

(2) Application was or is made on or after December 1, 1969, it must be shown that the noise levels of the airplane are no greater than those prescribed in Appendix C of this part.

(d) For aircraft to which paragraph (b) (1) of this section applies and that do not meet Appendix C of this part, a time period will be placed on the type certificate. The type certificate will specify that, upon the expiration of this time period, the type certificate will be subject to suspension or modification under section 611 of the Federal Aviation Act of 1958 (49 U.S.C. 1431) unless the type design of aircraft produced under that type certificate on and after the expiration date is modified to show compliance with Appendix C. With respect to any possible suspensions or modifications under this paragraph, the certificate holder shall have the same notice and appeal rights as are contained in section 609 of the Federal Aviation Act of 1958 (49 U.S.C. 1429).

Subpart D [Reserved]

Subpart E [Reserved]

Subpart F—Propeller Driven Small Airplanes

§ 36.501 Noise limits.

(a) Compliance with this subpart must be shown for—

(1) Propeller driven small airplanes for which application for the issuance of a type certificate in the normal, utility, acrobatic, transport, or restricted category is made on or after October 10, 1973; and

(2) Propeller driven small airplanes for which application is made for the original issuance of a standard airworthiness certificate or restricted category airworthiness certificate, and that have not had any flight time before January 1, 1980 (regardless of date of application).

(b) Compliance with this subpart must be shown with noise levels measured and corrected as prescribed in Parts B and C of Appendix F, or under approved equivalent procedures.

(c) For airplanes covered by this section, it must be shown that the noise level of the airplane is no greater than the applicable limit prescribed in Part D of Appendix F.

(Title I of the National Environmental Policy Act of 1969 (42 U.S.C. 4321 et seq.); and EO 11514, Mar. 5, 1970.) [Docket No. 13243, 40 FR 1034, Jan. 6, 1975]

Subpart G—Operating Limitations and Information

§ 36.1501 Procedures and other information.

All procedures, and other information for the flight crew, that are employed for obtaining the noise reductions prescribed in this Part must be developed. This must include noise levels achieved during type certification.

(Title I of the National Environmental Policy Act of 1969 (42 U.S.C. 4321 et seq.); and EO 11514, Mar. 5, 1970.) [Docket No. 13243, 40 FR 1035, Jan. 6, 1975]

§ 36.1581 Manuals, markings, and placards.

(a) If an Airplane Flight Manual is approved, the approved portion of the Airplane Flight Manual must contain procedures and other information approved under § 36.1501. If an Airplane Flight Manual is not approved, the procedures and information must be furnished in any combination of approved manual material, markings, and placards.

(b) The following statement must be furnished near the listed noise levels:

No determination has been made by the Federal Aviation Administration that the noise levels of this airplane are or should be acceptable or unacceptable for operation at, into, or out of, any airport.

(c) For subsonic transport category large airplanes and turbojet powered airplanes, for which the weight used in meeting the takeoff or landing noise requirements of this Part is less than the maximum weight or design landing weight, respectively, established under the applicable airworthiness requirements, those lesser weights must be furnished, as operating limitations, in the operating limitations section of the Airplane Flight Manual.

(d) For propeller driven small airplanes for which the weight used in meeting the flyover noise requirements of this Part is less than the maximum weight by an amount exceeding the amount of fuel needed to conduct the test, that lesser weight must be furnished, as an operating limitation, in the operating limitations section of an approved Airplane Flight Manual, in approved manual material, or on an approved placard.

(e) Except as provided in paragraphs (c) and (d) of this section, no operating limitations are furnished under this Part.

(Title I of the National Environmental Policy Act of 1969 (42 U.S.C. 4321 et seq.); and EO 11514, Mar. 5, 1970.) [Docket No. 13243, 40 FR 1036, Jan. 6, 1975]

APPENDIX A—AIRCRAFT NOISE MEASUREMENT UNDER § 36.101

Section A36.1 Noise certification test and measurement conditions—(a) General. This section prescribes the conditions under which noise type certification tests must be conducted and the measurement procedures that must be used to measure the noise made by the aircraft for which the test is conducted.

(b) **General test conditions.** (1) Tests to show compliance with established noise type certification levels must consist of a series of takeoffs and landings during which measurements must be taken at the measuring points defined in Appendix C of this part. The sideline noise measurements must also be made at symmetrical locations on each side of the runway. On each test takeoff, simultaneous measurements must be made at the sideline measuring points on both sides of the runway and also at the takeoff flyover measuring point. If the height of the ground at each measuring point differs from that of the nearest point on the runway by more than 20 feet, corrections must be made as defined in § A36.3(d) of this appendix.

(2) **Locations for measuring noise from an aircraft in flight** must be surrounded by relatively flat terrain having no excessive sound absorption characteristics such as might be caused by thick, matted, or tall

grass, shrubs, or wooded areas. No obstructions which significantly influence the sound field from the aircraft may exist within a conical space above the measurement position, the cone being defined by an axis normal to the ground and by a half-angle 75° from this axis.

(3) The tests must be carried out under the following weather conditions:

(i) No rain or other precipitation.
(ii) Relative humidity not higher than 90 percent or lower than 30 percent.
(iii) Ambient temperature not above 86° F. and not below 41° F. at 10 meters above ground.

(iv) Airport reported wind not above 10 knots and crosswind component not above 5 knots at 10 meters above ground.

(v) No temperature inversion or anomalous wind conditions that would significantly affect the noise level of the aircraft when the noise is recorded at the measuring points defined in Appendix C of this part.

(c) **Aircraft testing procedures.** (1) The aircraft testing procedures and noise measurements must be conducted and processed in an approved manner to yield the noise evaluation measure designated as Effective Perceived Noise Level, EPNL, in units of EPNdB, as described in Appendix B of this part.

(2) The aircraft height and lateral position relative to the extended centerline of the runway must be determined by a method independent of normal flight instrumentation such as radar tracking, theodolite triangulation, or photographic scaling techniques to be approved by the FAA.

(3) The aircraft position along the flight path must be related to the noise recorded at the noise measurement locations by means of synchronizing signals. The position of the aircraft must be recorded relative to the runway from a point at least 4 nautical miles from threshold to touchdown during the approach and at least 6 nautical miles from the start of roll during the takeoff.

(4) The takeoff test may be conducted at a weight different from the maximum takeoff weight at which noise certification is requested if the necessary EPNL correction does not exceed 2 EPNdB. The approach test may be conducted at a weight different from the maximum landing weight at which noise certification is requested provided the necessary EPNL correction does not exceed 1 EPNdB. Approved data may be used to determine the variation of EPNL with weight for both takeoff and approach test conditions.

(5) The takeoff test must meet the conditions of § C36.7 of Appendix C of this part.

(6) The approach test must be conducted with the aircraft stabilized and following a 3° + 0.5° approach angle and must meet the conditions of § 36.9.

(d) **Measurements.** (1) Position and performance data required to make the corrections referred to in § A36.3(e) of this

appendix must be automatically recorded at an approved sampling rate. Measuring equipment must be approved by the FAA.

(2) Position and performance data must be corrected, by the methods outlined in § A36.3(d) of this appendix to standard pressure at sea level, an ambient temperature of 77° F., a relative humidity of 70 percent, and zero wind.

(3) Acoustic data must be corrected by the methods of § A36.3(d) of this appendix to standard pressure at sea level, an ambient temperature of 77° F., and a relative humidity of 70 percent. Acoustic data corrections must also be made for a minimum distance of 370 feet between the aircraft's approach path and the approach measuring point, a takeoff path vertically above the flyover measuring point and for differences of more than 20 feet in elevation of measuring locations relative to the elevation of the nearest point of the runway.

(4) The airport tower or another facility must be approved for use as the location at which measurements of atmospheric parameters are representative of those conditions existing over the geographical area in which aircraft noise measurements are made. However, the surface wind velocity and temperature must be measured near the microphone at the approach, sideline, and take-off measurement locations, and the tests are not acceptable unless the conditions conform to § A36.1(b)(3) of this appendix.

(5) Enough sideline measurement stations must be used during tests so that the maximum sideline noise is clearly defined with respect to location and level.

Section A36.2 *Measurement of aircraft noise received on the ground*—(a) *General*.

(1) These measurements provide the data for determining one-third octave band noise produced by aircraft during testing procedures, at specific observation stations, as a function of time.

(2) Methods for determination of the distance from the observation stations to the aircraft include theodolite triangulation techniques, scaling aircraft dimensions on photographs made as the aircraft flies directly over the measurement points, radar altimeters, and radar tracking systems. The method used must be approved.

(3) Sound pressure level data for noise type certification purposes must be obtained with approved acoustical equipment and measurement practices.

(b) *Measurement system*. (1) The acoustical measurement system must consist of approved equipment equivalent to the following:

(i) A microphone system with frequency response compatible with measurement and analysis system accuracy as stated in paragraph (c) of this section.

(ii) Tripods or similar microphone mountings that minimize interference with the sound being measured.

(iii) Recording and reproducing equipment characteristics, frequency response, and dynamic range compatible with the response and accuracy requirements of paragraph (c) of this section.

(iv) Acoustic calibrators using sine wave or broadband noise of known sound pressure level. If broadband noise is used, the signal must be described in terms of its average and maximum rms value for a nonoverload signal level.

(v) Analysis equipment with the response and accuracy requirements of paragraph (d) of this section.

(c) *Sensing, recording, and reproducing equipment*. (1) The sound produced by the aircraft shall be recorded in such a way that the complete information, time history included, is retained. A magnetic tape recorder is acceptable.

(2) The characteristics of the system must comply with the recommendations given in International Electrotechnical Commission (IEC) Publication No. 179 with regard to the sections concerning microphone and amplifier characteristics. The text and specifications of IEC Publication No. 179 entitled: "Precision Sound Level Meters" are incorporated by reference into this part and are made a part hereof as provided in 5 U.S.C. 552(a)(1) and 1 CFR Part 20. This publication was published in 1965 by the Bureau Central de la Commission Electrotechnique Internationale located at 1, rue de Varembé, Geneva, Switzerland, and copies may be purchased at that place. Copies of this publication are available for examination at the DOT Library, Federal Office Building 10A Branch and at the Office of Noise Abatement both located at Headquarters, Federal Aviation Administration, 800 Independence Avenue, Washington, D.C. Moreover, copies of this publication are available for examination at the Regional Offices of the FAA. Furthermore, a historic, official file will be maintained by the Office of Noise Abatement and will contain any changes made to this publication.

(3) The response of the complete system to a sensibly plane progressive sinusoidal wave of constant amplitude must lie within the tolerance limits specified in IEC Publication No. 179, over the frequency range 45 to 11,200 Hz.

(4) If limitations of the dynamic range of the equipment make it necessary, high frequency preemphasis must be added to the recording channel with the converse de-emphasis on playback. The preemphasis must be applied such that the instantaneous recorded sound pressure level of the noise signal between 800 and 11,200 Hz does not vary more than 20 dB between the maximum and minimum one-third octave bands.

(5) The equipment must be acoustically calibrated using facilities for acoustic free-field calibration and electronically calibrated as stated in paragraph (d) of this section.

(6) A windscreen must be employed with the microphone during all measurements of aircraft noise when the wind speed is in excess of 6 knots. Corrections for any insertion loss produced by the windscreen, as a function of frequency, must be applied to the measured data and the corrections applied must be reported.

(d) *Analysis equipment.* (1) A frequency analysis of the acoustical signal shall be performed using one-third octave filters complying with the recommendations given in International Electrotechnical Commission (IEC) Publication No. 225. The text and specifications of IEC publication No. 225 entitled "Octave, Half-Octave and Third-Octave Band Filters Intended for the Analysis of Sounds and Vibrations" are incorporated by reference into this part and are made a part hereof as provided in 5 U.S.C. 552(a) (1) and 1 CFR Part 20. This publication was published in 1966 by the Bureau Central de la Commission Electrotechnique Internationale located at 1, rue de Varembe, Geneva, Switzerland, and copies may be purchased at that place. Copies of this publication are available for examination at the Office of Noise Abatement and at the DOT Library, Federal Office Building 10A Branch both located at Headquarters, Federal Aviation Administration, 800 Independence Avenue, Washington, D.C. Moreover, copies of this publication are available for examination at the Regional Offices of the FAA. Furthermore a historic, official file will be maintained by the Office of Noise Abatement and will contain any changes made to this publication.

(2) A set of 24 consecutive one-third octave filters must be used. The first filter of the set must be centered at a geometric mean frequency of 50 Hz and the last of 10 kHz.

(3) The analyzer indicating device must be analog, digital, or a combination of both. The preferred sequence of signal processing is:

- (i) Squaring the one-third octave filter outputs;
- (ii) Averaging or integrating; and
- (iii) Linear to logarithmic conversion.

The indicating device must have a minimum crest factor capacity of 3 and shall measure, within a tolerance of ± 1.0 dB, the true root-mean-square (rms) level of the signal in each of the 24 one-third octave bands. If other than a true rms device is utilized, it must be calibrated for nonsinusoidal signals and time varying levels. The calibration must provide means for converting the output levels to true rms values.

(4) The dynamic response of the analyzer to input signals of both full-scale and 20 dB less than full-scale amplitude, shall conform to the following two requirements:

- (1) When a sinusoidal pulse of 0.5-second duration at the geometrical mean frequency of each one-third octave band is applied to

the input, the maximum output value shall read $4 \text{ dB} \pm 1 \text{ dB}$ less than the value obtained for a steady state sinusoidal signal of the same frequency and amplitude.

- (1) The maximum output value shall exceed the final steady state value by 0.5 ± 0.5 dB when a steady state sinusoidal signal at the geometrical mean frequency of each one-third octave band is suddenly applied to the analyzer input and held constant.

- (5) A single value of the rms level must be provided every 0.5 ± 0.01 second for each of the 24 one-third octave bands. The levels from all of the 24 one-third octave bands must be obtained within a 50-millisecond period. No more than 5 milliseconds of data from any 0.5-second period may be excluded from the measurement.

- (6) The amplitude resolution of the analyzer must be at least 0.25 dB.

- (7) Each output level from the analyzer must be accurate within ± 1.0 dB with respect to the input signal, after all systematic errors have been eliminated. The total systematic errors for each of the output levels must not exceed ± 3 dB. For contiguous filter systems, the systematic correction between adjacent one-third octave channels may not exceed 4 dB.

- (8) The dynamic range capability of the analyzer for display of a single aircraft noise event must be at least 55 dB in terms of the difference between full-scale output level and the maximum noise level of the analyzer equipment.

- (9) The complete electronic system must be subjected to a frequency and amplitude electrical calibration by the use of sinusoidal or broadband signals at frequencies covering the range of 45 to 11,200 Hz, and of known amplitudes covering the range of signal levels furnished by the microphone. If broadband signals are used, they must be described in terms of their average and maximum rms values for a nonoverload signal level.

(e) *Noise measurement procedures.* (1) The microphones must be oriented so that the maximum sound received arrives as nearly as reasonable in the direction for which the microphones are calibrated. The microphones must be placed so that their sensing elements are approximately 4 feet above ground.

- (2) Immediately prior to and after each test, a recorded acoustic calibration of the system must be made in the field with an acoustic calibrator for the two purposes of checking system sensitivity and providing an acoustic reference level for the analysis of the sound level data.

- (3) For the purpose of minimizing equipment or operator error, field calibrations must be supplemented with the use of an insert voltage device to place a known signal at the input of the microphone, just prior to and after recording aircraft noise data.

- (4) The ambient noise, including both acoustical background and electrical noise

of the measurement system, must be recorded and determined in the test area with the system gain set at levels which will be used for aircraft noise measurements.

Section A36.3 *Reporting and correcting measured data*—(a) *General*. Data representing physical measurements or corrections to measured data must be recorded in permanent form and appended to the record except that corrections to measurements for normal equipment response deviations need not be reported. All other corrections must be approved. Estimates must be made of the individual errors inherent in each of the operations employed in obtaining the final data.

(b) *Data reporting*. (1) Measured and corrected sound pressure levels must be presented in one-third octave band levels obtained with equipment conforming to the standards described in § A36.2 of this appendix.

(2) The type of equipment used for measurement and analysis of all acoustic aircraft performance and meteorological data must be reported.

(3) The following atmospheric environmental data, measured at hourly intervals or less during the test period at the observation points prescribed in § A36.1(d)(4) of this appendix, must be reported:

- (i) Air temperature in degrees Fahrenheit and relative humidity in percent.
- (ii) Maximum, minimum, and average wind in knots and their direction.
- (iii) Atmospheric pressure in inches of Mercury.

(4) Comments on local topography, ground cover, and events that might interfere with sound recordings must be reported.

(5) The following aircraft information must be reported:

(i) Type, model, and serial numbers (if any) of aircraft and engines.

(ii) Gross dimensions of aircraft and location of engines.

(iii) Aircraft gross weight for each test run.

(iv) Aircraft configuration such as flap and landing gear positions.

(v) Airspeed in knots.

(vi) Engine performance in pounds of net thrust, engine pressure ratios, jet exit temperatures, and fan or compressor shaft rev./min. as recorded by cockpit instruments and manufacturer's data.

(vii) Aircraft height in feet determined by a method independent of cockpit instrumentation such as radar tracking theodolite triangulation, or approved photographic techniques.

(6) Aircraft speed and position and engine performance parameters must be recorded at an approved sampling rate sufficient to correct to the noise type certification reference conditions prescribed in § A36.3(c) of this appendix. Lateral position relative to the

extended centerline of the runway, configuration, and gross weight must be reported.

(c) *Noise type certification reference conditions*—(1) *Meteorological conditions*. Aircraft position and performance data and the noise measurements must be corrected to the following noise type certification reference atmospheric conditions:

(a) Sea level pressure of 2116 psf (76 cm mercury).

(b) Ambient temperature of 77° F. (ISA + 10° C.).

(c) Relative humidity of 70 percent.

(d) Zero wind.

(2) *Aircraft conditions*. The reference condition for takeoff is the maximum weight except as provided in § 36.1581(b).

The reference conditions for approach are:

(a) Design landing weight, except as provided in § 36.1581(b).

(b) Approach angle of 3°.

(c) Aircraft height of 370 feet above noise measuring station.

(d) *Data corrections*. (1) The noise data must be corrected to the noise type certification reference conditions as stated in § A36.3(c) of this appendix. The measured atmospheric conditions must be those obtained in accordance with § A36.1(d)(4) of this appendix. Atmospheric attenuation of sound requirements are given in § A36.5 of this appendix.

(2) The measured flight path must be corrected by an amount equal to the difference between the applicant's predicted flight paths for the test conditions and for the noise type certification reference conditions. Necessary corrections relating to aircraft flight path or performance may be derived from approved data other than certification test data. The flight path correction procedure for approach noise must be made with reference to a fixed aircraft height of 370 feet and a glide angle of 3°. The effective perceived noise level correction must be less than 2 EPNdB to allow for:

(a) The aircraft not passing vertically above the measuring point.

(b) The difference between 370 feet and the actual minimum distance of the aircraft's H&S antenna from the approach measuring points.

(c) The difference between the actual approach angle and 3°.

Detailed correction requirements are given in § A36.6 of this appendix.

(3) If aircraft sound pressure levels do not exceed the background sound pressure levels by at least 10 dB in any one-third octave band, approved corrections for the contribution of background sound pressure levels to observed sound pressure levels must be applied.

(e) *Validity of results*. (1) The test results must produce three average EPNL val-

ues and their 90 percent confidence limits, each being the arithmetic average of the corrected acoustical measurements for all valid test runs at the takeoff, approach, and sideline measuring points, respectively. If more than one acoustic measurement system is used at any single measurement location (such as for the symmetrical sideline measuring points), the resulting data for each test run must be averaged as a single measurement.

(2) The minimum sample size acceptable for each of the three certification measuring points is six. The samples must be large enough to establish statistically for each of the three average noise type certification levels a 90 percent confidence limit not exceeding ± 1.5 EPNdB. No test result may be omitted from the average process unless otherwise specified by the FAA.

(3) The average EPNL values and their 90 percent confidence limits obtained by the foregoing process must be those by which the noise performance of the aircraft is assessed against the noise type certification criteria, and must be reported.

Section A36.4 Symbols and units—(a) General. The symbols used in Appendices A and B of this part have the following meanings.

Symbol	Unit	Meaning
ant		Antilogarithm to the Base 10.
C(k)	dB	Tone Correction. The factor to be added to PNL(k) to account for the presence of spectral irregularities such as tones at the k-th increment of time.
d	sec	Duration Time. The length of the significant noise time history being the time interval between the limits of t(1) and t(2) to the nearest second.
D	dB	Duration Correction. The factor to be added to PNL _M to account for the duration of the noise.
EPNL	EPNdB	Effective Perceived Noise Level. The value of PNL adjusted for both the presence of discrete frequencies and the time history. (The unit EPNdB is used instead of the unit dB.)
f(l) or \bar{f}	Hz	Frequency. The geometrical mean frequency for the l-th one-third octave band.
F(l, k)	dB	Delta-dB. The difference between the original and background sound pressure levels in the l-th one-third octave band at the k-th interval of time.
s	dB	dB-Down. The level to be subtracted from PNL _{TM} that defines the duration of the noise.
H	%	Relative Humidity. The ambient atmospheric relative humidity.
(l) or l		Frequency Band Index. The numerical indicator that denotes any one of the 24 one-third octave bands with geometrical mean frequencies from 80 to 10,000 Hz.

Symbol	Unit	Meaning
(k)		Time Increment Index. The numerical indicator that denotes the number of equal time increments that have elapsed from a reference zero.
log		Logarithm to the Base 10.
log n(a)		Noise Discontinuity Coordinate. The log n value of the intersection point of the straight lines representing the variation of SPL with log n.
M(b), M(c)		Noise Inverse Slope. The reciprocals of the slopes of the straight lines representing the variation of SPL with log n.
n	noy	Perceived Noisiness. The perceived noisiness at any instant of time that occurs in a specified frequency range.
n(l, k)	noy	Perceived Noisiness. The perceived noisiness at the k-th instant of time that occurs in the l-th one-third octave band.
n(k)	noy	Maximum Perceived Noisiness. The maximum value of all of the 24 values of n(l) that occurs at the k-th instant of time.
N(k)	noy	Total Perceived Noisiness. The total perceived noisiness at the k-th instant of time calculated from the 24 instantaneous values of n(l, k).
p(b), p(e)		Noise Slope. The slopes of the straight lines representing the variation of SPL with log n.
PNL	PNdB	Perceived Noise Level. The perceived noise level at any instant of time (the unit PNdB is used instead of the unit dB).
PNL(k)	PNdB	Perceived Noise Level. The perceived noise level calculated from the 24 values of SPL (l, k) at the k-th increment of time. (The unit PNdB is used instead of the unit dB.)
PNLM	PNdB	Maximum Perceived Noise Level. The maximum value of PNL(k) that occurs during the aircraft flyover. (The unit PNdB is used instead of the unit dB.)
PNLT	PNdB	Tone Corrected Perceived Noise Level. The value of PNL adjusted for the presence of spectral irregularities (discrete frequencies) at any instant of time. (The unit PNdB is used instead of the unit dB.)
PNLT(k)	PNdB	Tone Corrected Perceived Noise Level. The value of PNL(k) adjusted for the presence of discrete frequencies that occurs at the k-th increment of time. (The unit PNdB is used instead of the unit dB.)
PNLTM	PNdB	Maximum Tone Corrected Perceived Noise Level. The maximum value of PNLT(k) that occurs during the aircraft flyover. (The unit PNdB is used instead of the unit dB.)

Symbol	Unit	Meaning	Symbol	Unit	Meaning
$s(l, k)$	dB	<i>Slope of Sound Pressure Level.</i> The change in level between adjacent one-third octave band sound pressure levels at the l-th band for the k-th instant of time.	a_{10}	dB/foot	<i>Reference Atmospheric Absorption.</i> The atmospheric attenuation of sound that occurs in the l-th one-third octave band for the reference atmospheric temperature and relative humidity.
$\Delta s(l, k)$	dB	<i>Change in Slope of Sound Pressure Level.</i>	a_{10}'	dB/1000 feet	
$s'(l, k)$	dB	<i>Adjusted Slope of Sound Pressure Level.</i> The change in level between adjacent adjusted one-third octave band sound pressure levels at the l-th band for the k-th instant of time.	β	degrees	<i>First Constant Climb Angle.</i>
$\bar{s}(l, k)$	dB	<i>Average Slope of Sound Pressure Level.</i>	γ	degrees	<i>Second Constant Climb Angle.</i>
SPL	dB re 0.0002 microbar	<i>Sound Pressure Level.</i> The sound pressure level at any instant of time that occurs in a specified frequency range.	δ	degrees	<i>Thrust Cutback Angle.</i> The angles defining the points on the takeoff flight path at which thrust reduction is started and ended respectively.
SPL(a)	dB re 0.0002 microbar	<i>Noise Discontinuity Coordinate.</i> The SPL value of the intersection point of the straight lines representing the variation of SPL with log n.	ϵ	degrees	<i>Approach Angle.</i>
SPL(b)	dB re 0.0002 microbar	<i>Noise Intercept.</i> The intercepts on the SPL-axis of the straight lines representing the variation of SPL with log n.	θ	degrees	<i>Takeoff Noise Angle.</i> The angle between the flight path and noise path for takeoff operation. It is identical for both measured and corrected flight paths.
SPL(l, k)	dB re 0.0002 microbar	<i>Sound Pressure Level.</i> The sound pressure level at the k-th instant of time that occurs in the l-th one-third octave band.	λ	degrees	<i>Approach Noise Angle.</i> The angle between the flight path and the noise path for approach operation. It is identical for both measured and corrected flight paths.
SPL'(l, k)	dB re 0.0002 microbar	<i>Adjusted Sound Pressure Level.</i> The best approximation to background level in the l-th one-third octave band for the k-th instant of time.	$\Delta 1$	EPNdB	<i>PNLT Correction.</i> The correction to be added to the EPNL calculated from measured data to account for noise level changes due to differences in atmospheric absorption and noise path length between reference and test conditions.
SPL''(l, k)	dB re 0.0002 microbar	<i>Background Sound Pressure Level.</i> The final approximation to background level in the l-th one-third octave band for the k-th instant of time.	$\Delta 2$	EPNdB	<i>Noise Path Duration Correction.</i> The correction to be added to the EPNL calculated from measured data to account for noise level changes due to the noise duration because of differences in flyover altitude between reference and test condition.
SPL ₁	dB re 0.0002 microbar	<i>Maximum Sound Pressure Level.</i> The sound pressure level that occurs in the l-th one-third octave band of the spectrum for PNLT _M .	$\Delta 3$	EPNdB	<i>Weight Correction.</i> The correction to be added to the EPNL calculated from measured data to account for noise level changes due to differences between maximum and test aircraft weights.
SPL _{1c}	dB re 0.0002 microbar	<i>Corrected Maximum Sound Pressure Level.</i> The sound pressure level that occurs in the l-th one-third octave band of the spectrum for PNLT _M corrected for atmospheric sound absorption.	$\Delta 4$	EPNdB	<i>Approach Angle Correction.</i> The correction to be added to the EPNL calculated from measured data to account for noise level changes due to differences between 3° and the test approach angle.
t	sec	<i>Elapsed Time.</i> The length of time measured from a reference zero.	$\Delta A B$	feet	<i>Takeoff Profile Changes.</i> The changes in the basic parameters defining the takeoff profile due to differences between reference and test conditions.
t(1), t(2)	sec	<i>Time Limit.</i> The beginning and end of the significant noise time history defined by h.	$\Delta \beta$	degrees	
Δt	sec	<i>Time Increment.</i> The equal increments of time for which PNL(k) and PNLT(k) are calculated.	$\Delta \gamma$	degrees	
T	sec	<i>Normalizing Time Constant.</i> The length of time used as a reference in the integration method for computing duration corrections.	$\Delta \delta$	degrees	
T	°F	<i>Temperature.</i> The ambient atmospheric temperature.	$\Delta \epsilon$	degrees	
a_{10}	dB/foot	<i>Test Atmospheric Absorption.</i>			
a_{10}'	dB/1000 feet	<i>The atmospheric attenuation of sound that occurs in the l-th one-third octave band for the measured atmospheric temperature and relative humidity.</i>			

FLIGHT PROFILE IDENTIFICATION POSITIONS

Position	Description
A	Start of takeoff roll.
B	Liftoff.
C	Start of first constant climb.
D	Start of thrust reduction.
E	Start of second constant climb.
E _c	Start of second constant climb on corrected flight path.

**FLIGHT PROFILE IDENTIFICATION
POSITIONS—Continued**

Position	Description
F	End of noise certification takeoff flight path.
Fc	End of second constant climb on corrected flight path.
G	Start of noise certification approach flight path.
Gr	Start of noise certification approach on reference flight path.
H	Position on approach path directly above noise measuring station.
I	Start of level off.
Ir	Start of level off on reference approach flight path.
J	Touchdown.
K	Takeoff noise measuring station.
L	Sideline noise measuring station (not on flight track).
M	End of noise type certification takeoff flight track.
N	Approach noise measuring station.
O	Threshold of approach end of runway
P	Start of noise type certification approach flight track.
Q	Position on measured takeoff flight path corresponding to PNLTM at station K.
Qc	Position on corrected takeoff flight path corresponding to PNLTM at station K.
R	Position on measured takeoff flight path nearest to station K.
Rc	Position on corrected takeoff flight path nearest to station K.
S	Position on measured approach flight path corresponding to PNLTM at station N.
Sr	Position on reference approach flight path corresponding to PNLTM at station N.
T	Position on measured approach flight path nearest to station N.
Tr	Position on reference approach flight path nearest to station N.
X	Position on measured takeoff flight path corresponding to PNLTM at station L.

FLIGHT PROFILE DISTANCES

Distance	Unit	Meaning
AB	feet	Length of Takeoff Roll. The distance along the runway between the start of takeoff roll and lift off.
AK	feet	Takeoff Measurement Distance. The distance from the start of roll to the takeoff noise measurement station along the extended centerline of the runway.

Distance	Unit	Meaning
AM	feet	Takeoff Flight Track Distance. The distance from the start of roll to the takeoff flight track position along the extended centerline of the runway for which the position of the aircraft need no longer be recorded.
KQ	feet	Measured Takeoff Noise Path. The distance from station K to the measured aircraft position Q.
KQc	feet	Corrected Takeoff Noise Path. The distance from station K to the corrected aircraft position Qc.
KR	feet	Measured Takeoff Minimum Distance. The distance from station K to point R on the measured flight path.
KRc	feet	Corrected Takeoff Minimum Distance. The distance from station K to point Rc on the corrected flight path.
LX	feet	Measured Sideline Noise Path. The distance from station L to the measured aircraft position X.
NH	feet	Aircraft Approach Height. The vertical distance between the aircraft and the approach measuring station.
NS	feet	Measured Approach Noise Path. The distance from station N to the measured aircraft position S.
NSr	feet	Reference Approach Noise Path. The distance from station N to the reference aircraft position Sr.
NT	feet	Measured Approach Minimum Distance. The distance from station N to point T on the measured flight path.
NTr	feet	Reference Approach Minimum Distance. The distance from station N to point Tr on the corrected flight path; it equals 359 feet.
ON	feet	Approach Measurement Distance. The distance from the runway threshold to the approach measurement station along the extended centerline of the runway.
OP	feet	Approach Flight Track Distance. The distance from the runway threshold to the approach flight track position along the extended centerline of the runway for which the position of the aircraft need no longer be recorded.

Section A36.5 Atmospheric attenuation of sound—(a) General. The atmospheric attenuation of sound must be determined in accordance with the curves of Figure 15 presented in SAE ARP 866 or by the simplified procedure presented below. SAE ARP 866 is a publication entitled: "Standard Values of Atmospheric Absorption as a Function of Temperature and Humidity for Use in Evaluating Aircraft Flyover Noise" and the recommendations presented therein are incorporated by reference into this Part and

are made a part hereof as provided in 5 U.S.C. §22(a) (1) and 1 CFR Part 20. This publication was published on August 31, 1964, by the Society of Automotive Engineers, Inc., located at 2 Pennsylvania Plaza, New York, N.Y. 10001, and copies may be purchased at that place. Copies of this publication are available for examination at the DOT Library, Federal Office Building 10A Branch and at the Office of Noise Abatement both located at Headquarters, Federal Aviation Administration, 800 Independence Avenue, Washington, D.C. Moreover, copies of this publication are available for examination at the Regional Offices of the FAA. Furthermore, a historic, official file will be maintained by the Office of Noise Abatement and will contain any changes made to this publication.

(b) *Reference conditions.* For the reference atmospheric conditions of temperature and relative humidity equal to 77° F. and 70 percent, respectively, and for all other conditions of temperature and relative humidity where their product is equal to or greater than 4,000, the sound absorption must be expressed by the following equation:

$$\alpha_{10'} = f/500 \text{ (dB/1,000 ft.)}$$

$\alpha_{10'}$ is the atmospheric attenuation of sound that occurs in the 1-th one-third octave band for the reference atmospheric conditions and f is the geometrical mean frequency for the 1-th one-third octave band.

(c) *Nonreference conditions.* (1) For all atmospheric conditions of temperature and relative humidity where their product is equal to or less than 4,000, the relationship between sound absorption, frequency, temperature, and humidity must be expressed by the following equation:

$$500\alpha_{10'}/f = (2/3) [11/2] - (HT/1,000)$$

$\alpha_{10'}$ is the atmospheric attenuation of sound that occurs in the 1-th one-third octave band for a relative humidity of H percent and a temperature of T ° Fahrenheit.

(2) Figure A1 graphically illustrates the simplified relationship. The second equation represents the inclined line which is valid for all values of HT up to and including 4,000. For all values of 4,000 and greater, the horizontal line, represented by the first equation, is valid. The minimum, reference, and maximum values of humidity and temperature are indicated in Figure A1.

Section A36.6 *Detailed correction procedures*—(a) *General.* If the noise type certification test conditions are not equal to the noise certification reference conditions, appropriate positive corrections must be made to the EPNL calculated from the measured data. Differences between reference and test conditions which lead to positive corrections can result from the following:

(1) Atmospheric absorption of sound under test conditions greater than reference,

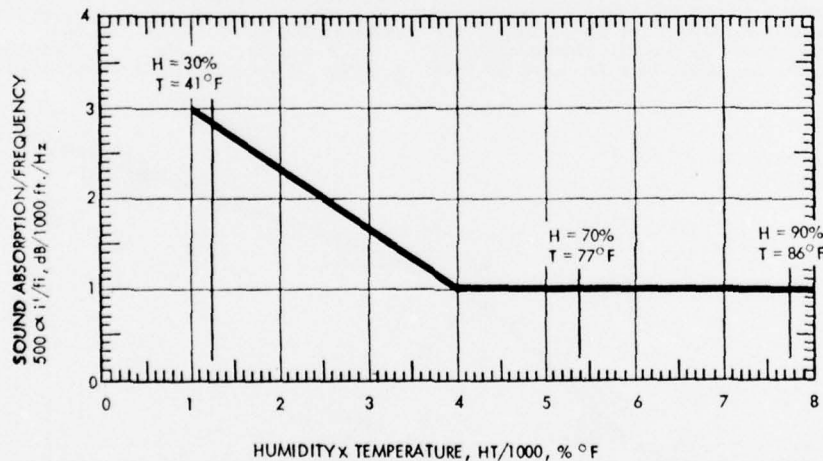

FIGURE A1. SIMPLIFIED RELATIONSHIP BETWEEN ATMOSPHERIC SOUND ATTENUATION, FREQUENCY, HUMIDITY, AND TEMPERATURE.

(2) Test flight path at higher altitude than reference, and

(3) Test weight less than maximum.

Negative corrections are permitted if the atmospheric absorption of sound under test conditions is less than reference and also if the test flight path is at a lower altitude than reference.

The takeoff test flight path can occur at a higher altitude than reference if the meteorological conditions permit superior aerodynamic performance ("cold day" effect). Conversely, the "hot day" effect can cause the takeoff test flight path to occur at a lower altitude than reference. The approach test flight path can occur at either higher or lower altitudes than reference irrespective of the meteorological conditions.

The correction procedures presented in the following discussion consist of one or more of five possible values added algebraically to the EPNL calculated as if the tests were conducted completely under the noise type certification reference conditions. The flight profiles must be determined for both takeoff and approach, and for both reference and test conditions. The test procedures require noise and flight path recordings with a synchronized time signal from which the test profile can be delineated, including the aircraft position for which PNLTM is observed at the noise measuring station. For takeoff, a flight profile corrected to reference conditions may be derived from manufacturer's data, and for approach, the reference profile is known.

The noise paths from the aircraft to the noise measuring station corresponding to PNLTM are determined for both the test

and reference profiles. The SPL values in the spectrum of PNLTM are then corrected for the effects of:

(1) Change in atmospheric sound absorption,

(2) Atmospheric sound absorption on the change in noise path length,

(3) Inverse square law on the change in noise path length.

The corrected values of SPL are then converted to PNLTM from which is subtracted PNLTM. The difference represents the correction to be added algebraically to the EPNL calculated from the measured data.

The minimum distances from both the test and reference profiles to the noise measuring station are calculated and used to determine a noise duration correction due to the change in the altitude of aircraft flyover. The duration correction is added algebraically to the EPNL calculated from the measured data.

From approved data in the form of curves or tables giving the variation of EPNL with takeoff weight and also for landing weight, corrections are determined to be added to the EPNL calculated from the measured data to account for noise level changes due to differences between maximum and test aircraft weights.

From approved data in the form of curves or tables giving the variation of EPNL with approach angle, corrections are determined to be added algebraically to the EPNL calculated from measured data to account for noise level changes due to differences between 3° and the test approach angle.

(b) Takeoff profiles. Figure A2 illustrates a typical takeoff profile. The aircraft begins

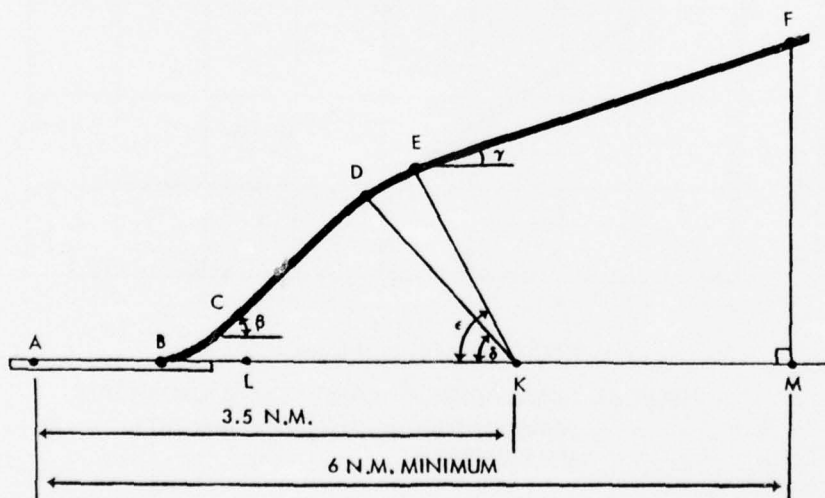

FIGURE A2. MEASURED TAKEOFF PROFILE.

the takeoff roll at point A, lifts off at point B, and initiates the first constant climb at point C at an angle β . The noise abatement thrust cutback is started at point D and completed at point E where the second constant climb is defined by the angle γ (usually expressed in terms of the gradient in percent).

The end of the noise type certification takeoff flight path is represented by aircraft position F whose vertical projection on the flight track (extended centerline of the runway) is point M. The position of the aircraft must be recorded for a distance AM of at least 6 nautical miles.

Position K is the takeoff noise measuring station whose distance AK is specified as 3.5 nautical miles. Position L is the sideline noise measuring station located on a line parallel to and a specified distance from the runway centerline where the noise level during takeoff is greatest.

The takeoff profile is defined by the following five parameters: AB, the length of takeoff roll; β , the first constant climb angle; γ , the second constant climb angle; and δ and ϵ , the thrust cutback angles. These five parameters are functions of the aircraft performance and weight and the atmospheric conditions of temperature, pressure, and wind velocity and direction. If the test conditions are not equal to the reference conditions, the corresponding test and reference profile parameters will be different as shown in Figure A3. The profile parameter changes, identified as ΔAB , $\Delta\beta$, $\Delta\alpha$, $\Delta\delta$, and $\Delta\epsilon$, can be derived from the manufacturer's data (approved by the FAA) and can be used to define the flight profile corrected to the reference conditions. The relationships be-

tween the measured and corrected takeoff flight profiles can then be used to determine the corrections, which if positive, must be applied to the EPNL calculated from the measured data.

NOTE: Under reference atmospheric conditions and with maximum takeoff weight, the gradient of the second constant climb angle, γ , is specified to be not less than 4 percent. However, the actual gradient will depend upon the test atmospheric conditions, assuming maximum takeoff weight and the parameters characterizing engine performance are constant (rpm, epr, or any other parameter used by the pilot).

Figure A4 illustrates portions of the measured and corrected takeoff flight paths including the significant geometrical relationships influencing sound propagation. EP represents the measured second constant flight path with climb angle γ , and EcF_c represents the corrected second constant flight path at reduced altitude and with reduced climb angle $\gamma - \Delta\gamma$.

Position Q represents the aircraft location on the measured takeoff flight path for which PNLTM is observed at the noise measuring station K, and Q_c is the corresponding position on the corrected flight path. The measured and corrected noise propagation paths are KQ and KQ_c, respectively, which form the same angle θ with their flight paths.

Position R represents the point on the measured takeoff flight path nearest the noise measuring station K, and R_c is the corresponding position on the corrected flight path. The minimum distance to the measured and corrected flight paths are indicated by the lines KR and KR_c, respectively, which are normal to their flight paths.

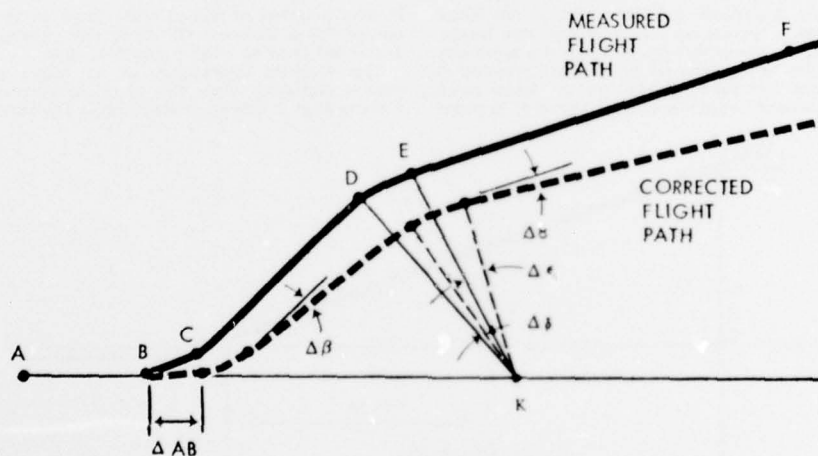

FIGURE A3. COMPARISON OF MEASURED AND CORRECTED TAKEOFF PROFILES.

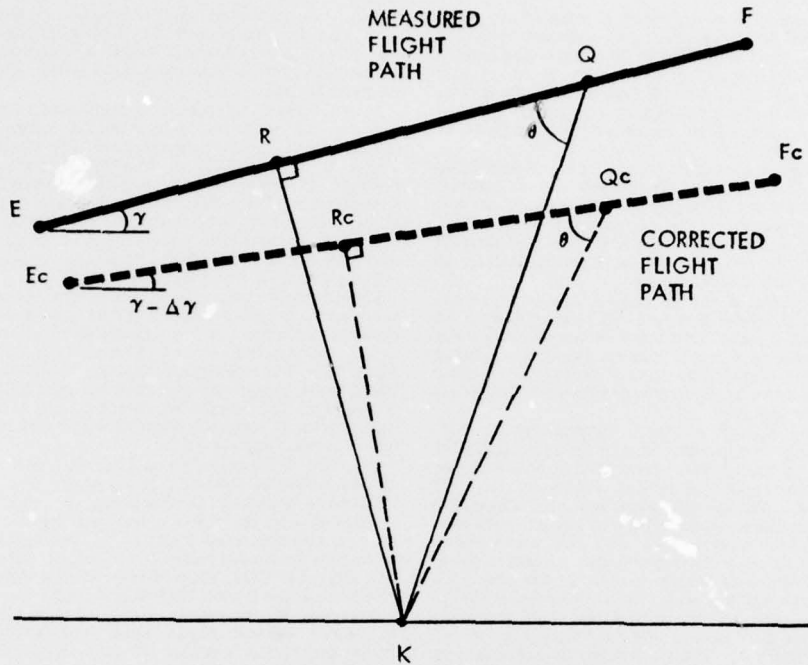

FIGURE A4. TAKEOFF PROFILE CHARACTERISTICS INFLUENCING SOUND PROPAGATION.

(c) Approach profiles. Figure A5 illustrates a typical approach profile. The beginning of the noise type certification approach profile is represented by aircraft position G whose vertical projection on the flight track (extended centerline of the runway) is point

P. The position of the aircraft must be recorded for a distance OP from the runway threshold O of at least 4 nautical miles.

The aircraft approaches at an angle γ , passes vertically over the noise measuring station N at a height of NH, begins the level

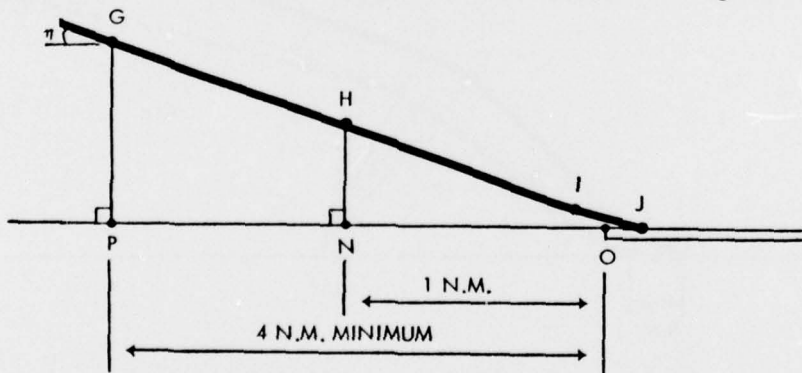

FIGURE A5. MEASURED APPROACH PROFILE.

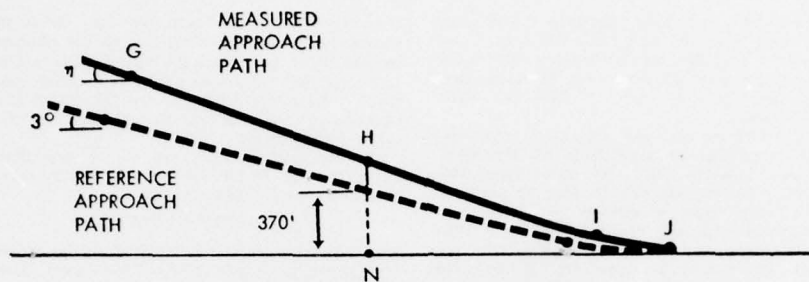

FIGURE A6. COMPARISON OF MEASURED AND CORRECTED APPROACH PROFILES.

off at position I, and touches down at position J. The distance ON is specified as 1.0 nautical mile.

The approach profile is defined by the approach angle η and the height NH which are functions of the aircraft operating conditions controlled by the pilot. If the measured approach profile parameters are different from the corresponding reference approach parameters (3° and 370 feet, respectively, as shown in Figure A6), corrections, if positive, must be applied to the EPNL calculated from the measured data.

Figure A7 illustrates portions of the measured and reference approach flight paths including the significant geometrical relationships influencing sound propagation. GI represents the measured approach path with approach angle η , and GrIr represents

the reference approach flight path at lower altitude and approach angle of 3° .

Position S represents the aircraft location on the measured approach flight path for which PNLTM is observed at the noise measuring station N, and Sr is the corresponding position on the reference approach flight path. The measured and corrected noise propagation paths are NS and NSr, respectively, which form the same angle λ with their flight paths.

Position T represents the point on the measured approach flight path nearest the noise measuring station N, and Tr is the corresponding point on the reference approach flight path. The minimum distances to the measured and reference flight paths are indicated by the lines NT and NTr, respectively, which are normal to their flight paths.

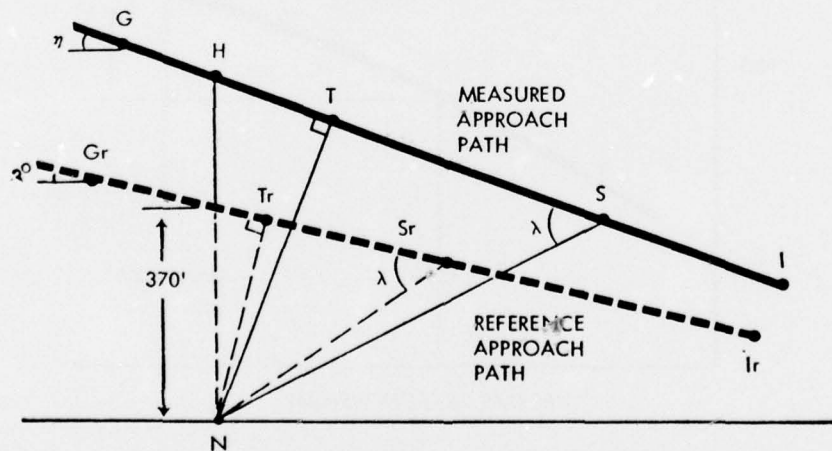

FIGURE A7. APPROACH PROFILE CHARACTERISTICS INFLUENCING SOUND PROPAGATION.

NOTE: The reference approach flight path is defined by $\gamma=3^\circ$ and $NH=370$ feet. Consequently, NTr can also be defined; $NTr=369$ feet to the nearest foot and is, therefore, considered to be one of the reference parameters.

(d) **PNLT corrections.** Whenever the ambient atmospheric conditions of temperature and relative humidity differ from the reference conditions (77° F. and 70 percent, respectively) and whenever the measured takeoff and approach flight paths differ from the corrected and reference flight paths respectively, it may be necessary or desirable to apply corrections to the EPNL values calculated from the measured data. If the corrections are required, they must be calculated as described below.

Referring to the takeoff flight path shown in Figure A4, the spectrum of PLNTM observed at station K, for the aircraft at position Q, is decomposed into its individual SPLI values. A set of corrected values are then computed as follows:

$$SPLic = SPLI + (a1 - a1o) KQ \\ + a1o (KQ - KQc) \\ + 20 \log (KQ/KQc)$$

where SPLI and SPLic are the measured and corrected sound pressure levels, respectively, in the i -th one-third octave band. The first correction term accounts for the effects of change in atmospheric sound absorption where $a1$ and $a1o$ are the sound absorption coefficients for the test and reference atmospheric conditions, respectively, for the i -th one-third octave band and KQ is the measured takeoff noise path. The second

correction term accounts for the effects of atmospheric sound absorption on the change in the noise path length where KQc is the corrected takeoff noise path. The third correction term accounts for the effects of the inverse square law on the change in the noise path length.

The corrected values of SPLic are then converted to PNLT and a correction term calculated as follows:

$$\Delta 1 = PNLT - PNLTM$$

which represents the correction to be added algebraically to the EPNL calculated from the measured data.

The same procedure is used for the approach flight path except that the values for SPLic relate to the approach noise paths shown in Figure A7 as follows:

$$SPLic = SPLI + (a1 - a1o) NS \\ + a1o (NS - NSr) \\ + 20 \log (NS/NSr)$$

where NS and NSr are the measured and reference approach noise paths, respectively. The remainder of the procedure is the same as for the takeoff flight path.

The same procedure is used for the sideline flight path except that the values for SPLic relate only to the measured sideline noise path as follows:

$$SPLic = SPLI + (a1 - a1o) LX$$

where LX is the measured sideline noise path from station L (Figure A2) to position X of the aircraft for which PNLTM is observed at station L. Only the correction term accounting for the effects of change in atmospheric

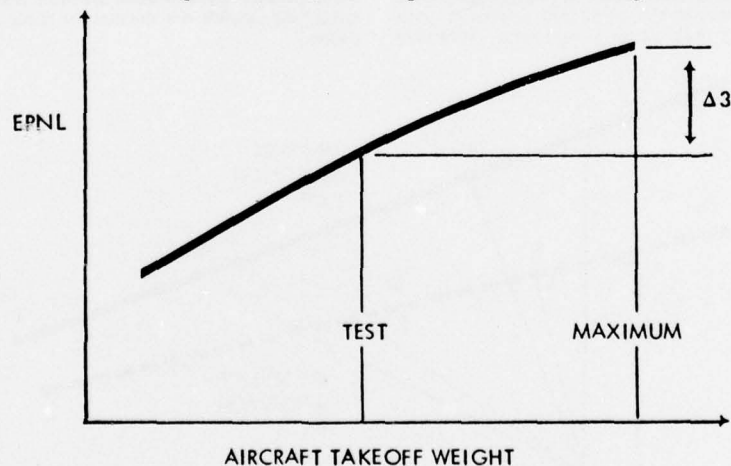

FIGURE A8. TAKEOFF WEIGHT CORRECTION FOR EPNL AT 3.5 NAUTICAL MILES FROM BRAKE RELEASE.

sound absorption is considered. The difference between the measured and corrected noise path lengths are assumed negligible for the sideline flight path. The remainder of the procedure is the same as for the takeoff flight path.

(e) *Duration corrections.* Whenever the measured takeoff and approach flight paths differ from the corrected and reference flight paths, respectively, it may be necessary or desirable to apply duration corrections to the EPNL values calculated from the measured data. If the corrections are required, they shall be calculated as described below.

Referring to the takeoff flight path shown in Figure A4, a correction term is calculated as follows:

$$\Delta 2 = -10 \log (KR/KRc)$$

which represents the correction to be added algebraically to the EPNL calculated from the measured data. The lengths KR and KRc are the measured and corrected takeoff minimum distances, respectively, from the noise measuring station K to the measured and corrected flight paths. The negative sign indicates that, for the particular case of a duration correction, the EPNL calculated from the measured data is reduced if the measured flight path is at a greater altitude than the corrected flight path.

The same procedure is used for the approach flight path except that the correction relates to the approach minimum distances shown in Figure A7 as follows:

$$\Delta 2 = -10 \log (NT/369)$$

where NT is the measured approach minimum distance from the noise measuring station N to the measured flight path and 369 feet is the minimum distance from station N to the reference flight path.

No duration correction is computed for the sideline flight path because the differences between the measured and corrected flight paths are assumed negligible.

(f) *Weight corrections.* Whenever the aircraft weight, during either the noise type certification takeoff, sideline, or approach test, is less than the corresponding maximum takeoff or landing weight, a correction must be applied to the EPNL value calculated from the measured data. The corrections are determined from approved data in the form of tables or curves such as schematically indicated in Figures A8 and A9. The data must be applicable to the noise type certification reference atmospheric conditions.

(g) *Approach angle corrections.* Whenever the aircraft approach angle during the noise type certification approach test is greater than 3°, a correction must be applied to the EPNL value calculated from the measured data. The corrections are determined from approved data in the form of tables or curves such as schematically indicated in Figure A10. The data must be applicable to the noise type certification reference atmospheric conditions and to the test landing weight.

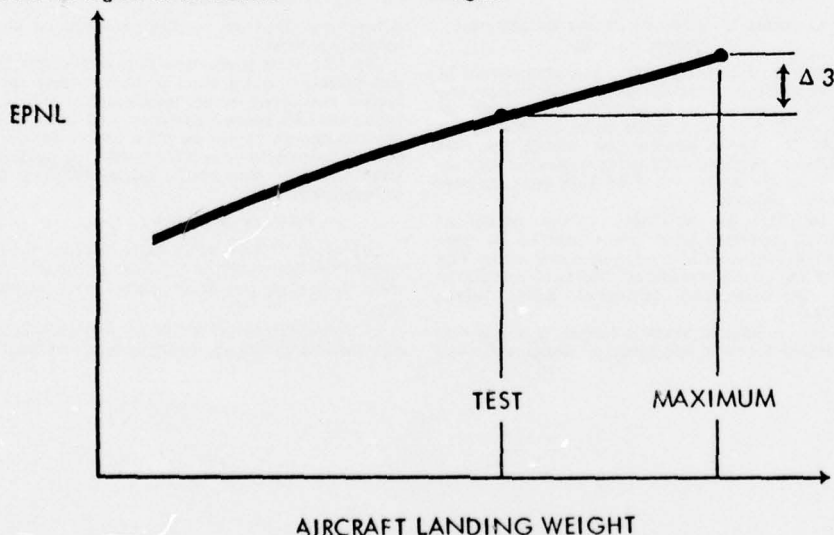

FIGURE A9. APPROACH WEIGHT CORRECTION FOR EPNL AT 1.0 NAUTICAL MILE FROM RUNWAY THRESHOLD.

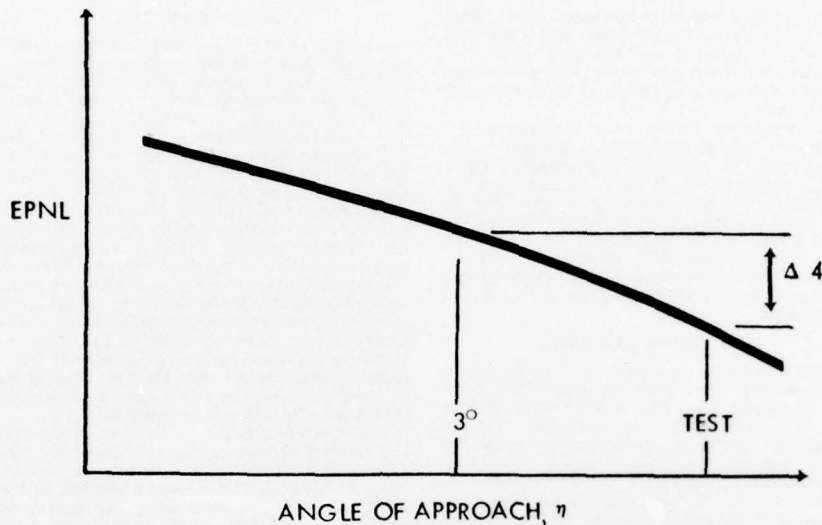

FIGURE A10. APPROACH ANGLE CORRECTION FOR EPNL AT 1.0 NAUTICAL MILE FROM RUNWAY THRESHOLD.

**APPENDIX B—AIRCRAFT NOISE EVALUATION
UNDER § 36.103**

Section B36.1 *General*. The procedures in this appendix must be used to determine the noise evaluation quantity designated as effective perceived noise level, EPNL, under § 36.103. These procedures, which use the physical properties of noise measured as prescribed by Appendix A of this part, consist of the following:

(a) The 24 one-third octave bands of sound pressure level are converted to perceived noisiness by means of a noy table. The noy values are combined and then converted to instantaneous perceived noise levels, PNL(k).

(b) A tone correction factor, C(k), is calculated for each spectrum to account for the

subjective response to the presence of the maximum tone.

(c) The tone correction factor is added to the perceived noise level to obtain tone corrected perceived noise levels, PNLT(k), at each one-half second increment of time. The instantaneous values of tone corrected perceived noise level are noted with respect to time and the maximum value, PNLT_M, is determined.

$$\text{PNLT}(k) = \text{PNL}(k) + C(k)$$

(d) A duration correction factor, D, is computed by integration under the curve of tone corrected perceived noise level versus time.

(e) Effective perceived noise level, EPNL, is determined by the algebraic sum of the maxi-

mum tone corrected perceived noise level and the duration correction factor.

$$EPNL = PNLTM + D$$

Section B36.2 *Perceived noise level.* Instantaneous perceived noise levels, PNL(k), must be calculated from instantaneous one-third octave band sound pressure levels, SPL(i,k), as follows:

Step 1. Convert each one-third octave band SPL(i,k), from 50 to 10,000 Hz, to perceived noisiness, n(i,k), by reference to Table B1, or to the mathematical formulation of the noy table given in § B36.7 of this appendix.

Step 2. Combine the perceived noisiness values, n(i,k), found in step 1 by the following formula:

$$N(k) = n(k) + 0.15 \left[\left[\sum_{i=1}^{24} n(i, k) \right] - n(k) \right] - 0.85n(k) + 0.15 \sum_{i=1}^{24} n(i, k)$$

where n(k) is the largest of the 24 values of n(i,k) and N(k) is the total perceived noisiness.

Step 3. Convert the total perceived noisiness, N(k), into perceived noise level, PNL(k), by the following formula:

$$PNL(k) = 40.0 + 33.3 \log N(k)$$

which is plotted in Figure B1. PNL(k) may also be obtained by choosing N(k) in the 1,000 Hz column of Table B1 and then reading the corresponding value of SPL(i,k) which, at 1,000 Hz, equals PNL(k).

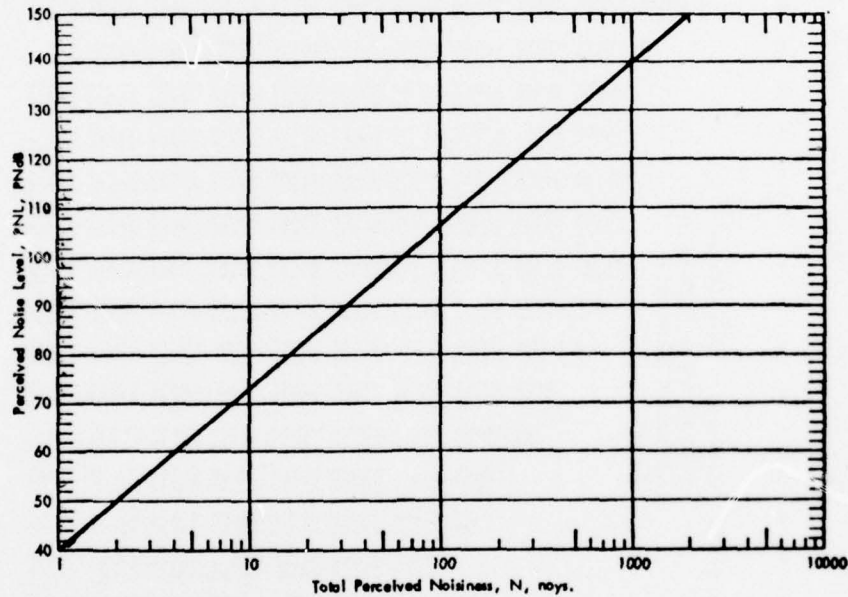

Figure B1. Perceived Noise Level as a Function of Noys.

Section B36.3 *Correction for spectral irregularities.* Noise having pronounced irregularities in the spectrum (for example, discrete frequency components or tones), must be adjusted by the correction factor $C(k)$ calculated as follows:

Step 1. Starting with the corrected sound pressure level in the 80 Hz one-third octave band (band number 3), calculate the changes in sound pressure level (or "slopes") in the remainder of the one-third octave bands as follows:

$$\begin{aligned} s(3,k) &= \text{no value} \\ s(4,k) &= \text{SPL}(4,k) - \text{SPL}(3,k) \\ &\vdots \\ s(1,k) &= \text{SPL}(1,k) - \text{SPL}[(1-1),k] \\ &\vdots \\ s(24,k) &= \text{SPL}(24,k) - \text{SPL}(23,k) \end{aligned}$$

Step 2. Encircle the value of the slope, $s(i,k)$, where the absolute value of the change in slope is greater than 5; that is, where

$$|\Delta s(i,k)| = |s(i,k) - s[(i-1),k]| > 5.$$

Step 3. (a) If the encircled value of the slope $s(i,k)$ is positive and algebraically greater than the slope $s[(i-1),k]$, encircle $\text{SPL}(i,k)$.

(b) If the encircled value of the slope $s(i,k)$ is zero or negative and the slope $s[(i-1),k]$ is positive, encircle $\text{SPL}[(i-1),k]$.

(c) For all other cases, no sound pressure level value is to be encircled.

Step 4. Omit all $\text{SPL}(i,k)$ encircled in Step 3 and compute new sound pressure levels $\text{SPL}'(i,k)$ as follows:

(a) For nonencircled sound pressure levels, let the new sound pressure levels equal the original sound pressure levels,

$$\text{SPL}'(i,k) = \text{SPL}(i,k)$$

(b) For encircled sound pressure levels in bands 1-23, let the new sound pressure level equal the arithmetic average of the preceding and following sound pressure levels,

$$\text{SPL}'(i,k) = (1/2)[\text{SPL}[(i-1),k] + \text{SPL}[(i+1),k]]$$

(c) If the sound pressure level in the highest frequency band ($i=24$) is encircled, let the new sound pressure level in that band equal

$$\text{SPL}'(24,k) = \text{SPL}(23,k) + s(23,k).$$

Step 5. Recompute new slopes $s'(i,k)$, including one for an imaginary 25-th band, as follows:

$$\begin{aligned} s'(3,k) &= s'(4,k) \\ s'(4,k) &= \text{SPL}'(4,k) - \text{SPL}'(3,k) \\ &\vdots \\ s'(i,k) &= \text{SPL}'(i,k) - \text{SPL}'[(i-1),k] \\ &\vdots \end{aligned}$$

$$\begin{aligned} s'(24,k) &= \text{SPL}'(24,k) - \text{SPL}'(23,k) \\ s'(25,k) &= s'(24,k) \end{aligned}$$

Step 6. For i from 3 to 23, compute the arithmetic average of the three adjacent slopes as follows:

$$\bar{s}(i,k) = (1/3)[s'(i,k) + s'[(i+1),k] + s'[(i+2),k]]$$

Step 7. Compute final adjusted one-third octave-band sound pressure levels, $\text{SPL}''(i,k)$, by beginning with band number 3 and proceeding to band number 24 as follows:

$$\begin{aligned} \text{SPL}''(3,k) &= \text{SPL}(3,k) \\ \text{SPL}''(4,k) &= \text{SPL}''(3,k) + \bar{s}(3,k) \end{aligned}$$

$$\text{SPL}''(i,k) = \text{SPL}''[(i-1),k] + \bar{s}[(i-1),k]$$

$$\text{SPL}''(24,k) = \text{SPL}''(23,k) + \bar{s}(23,k)$$

Step 8. Calculate the differences, $F(i,k)$, between the original and the adjusted sound pressure levels as follows:

$$F(i,k) = \text{SPL}(i,k) - \text{SPL}''(i,k)$$

and note only value greater than zero.

Step 9. For each of the 24 one-third octave bands, determine tone correction factors from the sound pressure level differences $F(i,k)$ and Table B2.

Step 10. Designate the largest of the tone correction factors, determined in Step 9, as $C(k)$. An example of the tone correction procedure is given in Table B3.

Tone corrected perceived noise levels $\text{PNLT}(k)$ are determined by adding the $C(k)$ values to corresponding $\text{PNL}(k)$ values, that is,

$$\text{PNLT}(k) = \text{PNL}(k) + C(k)$$

For any i -th one-third octave band, at any k -th increment of time, for which the tone correction factor is suspected to result from something other than (or in addition to) an actual tone (or any spectral irregularity other than aircraft noise), an additional analysis may be made using a filter with a bandwidth narrower than one-third of an octave. If the narrow band analysis corroborates that suspicion, then a revised value for the background sound pressure level, $\text{SPL}''(i,k)$, may be determined from the analysis and used to compute a revised tone correction factor, $F(i,k)$, for that particular one-third octave band.

Section B36.4 *Maximum tone corrected perceived noise level.* The maximum tone corrected perceived noise level, PNLTM , is the maximum calculated value of the tone corrected perceived noise level, $\text{PNLT}(k)$, calculated in accordance with the procedure of § B36.3 of this Appendix. Figure B2 is an example of a flyover noise time history where the maximum value is clearly indicated. Half-second time intervals, Δt , are small enough to obtain a satisfactory noise time history.

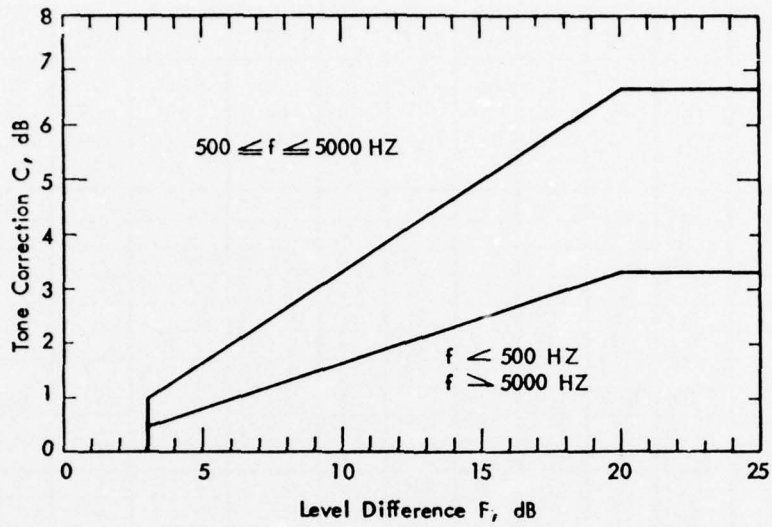

Frequency f, HZ	Level Difference F, dB	Tone Correction C, dB
50 ≤ f < 500	$F < 3$ $3 \leq F < 20$ $20 \leq F$	0 $F/6$ $3 \frac{1}{3}$
500 ≤ f ≤ 5000	$F < 3$ $3 \leq F < 20$ $20 \leq F$	0 $F/3$ $6 \frac{2}{3}$
5000 < f ≤ 10000	$F < 3$ $3 \leq F < 20$ $20 \leq F$	0 $F/6$ $3 \frac{1}{3}$

Table B2.. Tone Correction Factors

①	②	③	④	⑤	⑥	⑦	⑧	⑨	⑩	⑪
Band (i)	f Hz	SPL dB	S dB Step 1	ΔS dB Step 2	SPL' dB Step 4	S' dB Step 5	\bar{S} dB Step 6	SPL'' dB Step 7	F dB Step 8	C dB Step 9
1	50	-	-	-	-	-	-	-	-	-
2	63	-	-	-	-	-	-	-	-	-
3	80	70	-	-	70	-8	-2 1/3	70	-	-
4	100	62	-8	-	62	-8	+3 1/3	67 2/3	-	-
5	125	(70)	+③	16	71	+9	+6 2/3	71	-	-
6	160	80	+10	2	80	+9	+2 2/3	77 2/3	2 1/3	-
7	200	82	+②	8	82	+2	-1 1/3	80 1/3	1 2/3	-
8	250	(83)	+1	1	79	-3	-1 1/3	79	4	2/3
9	315	76	-⑦	8	76	-3	+ 1/3	77 2/3	-	-
10	400	(80)	+④	11	78	+2	+1	78	2	-
11	500	80	0	4	80	+2	0	79	1	-
12	630	79	-1	1	79	-1	0	79	-	-
13	800	78	-1	0	78	-1	- 1/3	79	-	-
14	1000	80	+2	3	80	+2	- 2/3	78 2/3	1 1/3	-
15	1250	78	-2	4	78	-2	- 1/3	78	-	-
16	1600	76	-2	0	76	-2	+ 1/3	77 2/3	-	-
17	2000	79	+3	5	79	+3	+1	78	1	-
18	2500	(85)	+6	3	79	0	- 1/3	79	6	[2]
19	3150	79	-⑥	12	79	0	-2 2/3	78 2/3	1/3	-
20	4000	78	-1	5	78	-1	-6 1/3	76	2	-
21	5000	71	-⑦	6	71	-7	-8	69 2/3	1 1/3	-
22	6300	60	-11	4	60	-11	-8 2/3	61 2/3	-	-
23	8000	54	-6	5	54	-6	-8	53	1	0
24	10000	45	-9	3	45	-9	-	45	-	-
						-9				

Step 1	③ (i) - ③ (i-1)
Step 2	④ (i) - ④ (i-1)
Step 3	see instructions
Step 4	see instructions
Step 5	⑥ (i) - ⑥ (i-1)

Step 6	[⑦ (i) + ⑦ (i+1) + ⑦ (i+2)] ÷ 3
Step 7	⑨ (i-1) + ⑧ (i-1)
Step 8	③ (i) - ⑨ (i)
Step 9	see Table B2

Table B3. Example of Tone Correction Calculation for a Turbofan Engine

If there are no pronounced irregularities in the spectrum, then the procedure of § B36.3 of this Appendix would be redundant since PNL(k) would be identically equal to

PNL(k). For this case, PNLTM would be the maximum value of PNL(k) and would equal PNLm.

Section B36.5 Duration correction. The

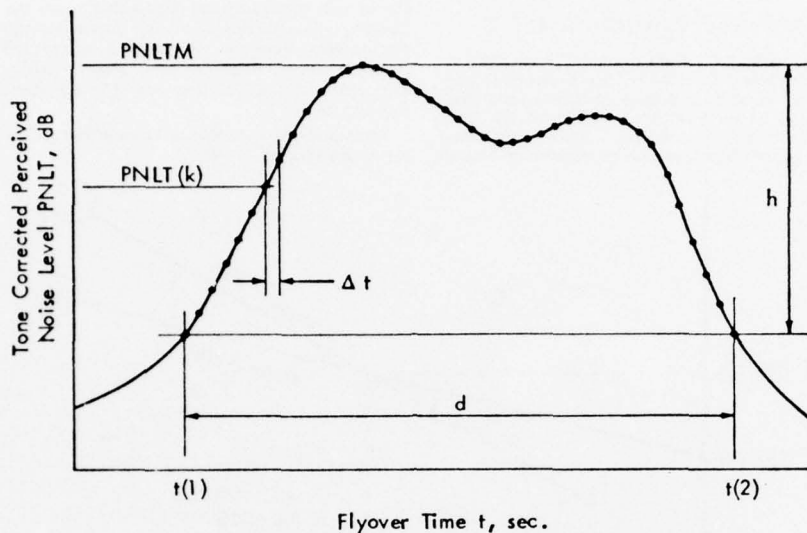

Figure B2. Example of Perceived Noise Level Corrected for Tones as a Function of Aircraft Flyover Time

duration correction factor D is determined by the integration technique defined by the expression:

$$D = 10 \log \left[\frac{1}{T} \int_{t(1)}^{t(2)} \text{ant} [\text{PNLT}/10] dt \right] - \text{PNLTM}$$

where T is a normalizing time constant, PNLTM is the maximum value of PNLT , and $t(1)$ and $t(2)$ are the limits of the significant noise time history.

Since PNLT is calculated from measured values of SPL , there will, in general, be no obvious equation for PNLT as a function of time. Consequently, the equation can be rewritten with a summation sign instead of an integral sign as follows:

$$D = 10 \log \left[\frac{1}{T} \sum_{k=1}^{d/\Delta t} \Delta t \text{ant} [\text{PNLT}(k)/10] \right] - \text{PNLTM}$$

where Δt is the length of the equal increments of time for which $\text{PNLT}(k)$ is calculated and d is the time interval to the nearest 1.0 second during which $\text{PNLT}(k)$ is within a specified value, h , of PNLTM .

Half-second time intervals for Δt are small enough to obtain a satisfactory history of the perceived noise level. A shorter time interval may be selected by the applicant provided approved limits and constants are used.

The following values for T , Δt , and h , must be used in calculating D :

$$\begin{aligned} T &= 10 \text{ sec,} \\ \Delta t &= 0.5 \text{ sec, and} \\ h &= 10 \text{ dB.} \end{aligned}$$

Using the above values, the equation for D becomes

$$D = 10 \log \left[\sum_{k=1}^d \text{ant} [\text{PNLT}(k)/10] \right] - \text{PNLTM} - 13$$

where the integer d is the duration time defined by the points that are 10 dB less than PNLTM .

If the 10 dB-down points fall between calculated $\text{PNLT}(k)$ values (the usual case), the applicable limits for the duration time must be chosen from the $\text{PNLT}(k)$ values closest to $\text{PNLTM} - 10$. For those cases with more than one peak value of $\text{PNLT}(k)$, the applicable limits must be chosen to yield the largest possible value for the duration time.

If the value of $\text{PNLT}(k)$ at the 10 dB-down points is 90 PNdB or less, the value of d may be taken as the time interval between the initial and the final times for which $\text{PNLT}(k)$ equals 90 PNdB.

Section B36.6 *Effective perceived noise level*. The total subjective effect of an aircraft flyover is designated "effective perceived noise level," EPNL , and is equal to the algebraic sum of the maximum value of the tone corrected perceived noise level, PNLTM , and the duration correction, D . That is,

$$\text{EPNL} = \text{PNLTM} + D$$

where PNLTM and D are calculated under §§ B36.4 and B36.5 of this appendix.

The above equation can be rewritten by substituting the equation for D from § B36.5 of this appendix, that is,

$$EPNL = 10 \log \left[\sum_{k=1}^M \text{ant} \{ PNL T(k)/10 \} \right] - 13$$

Section B36.7 *Mathematical formulation of noy tables.* The relationship between sound pressure level and perceived noisiness given in Table B1 is illustrated in Figure B3. The variation of SPL with log n for a given one-third octave band can be expressed by either

one or two straight lines depending upon the frequency range. Figure B3(a) illustrates the double line case for frequencies below 400 Hz, and above 6,300 Hz and Figure B3(b) illustrates the single line case for all other frequencies.

The important aspects of the mathematical formulation are:

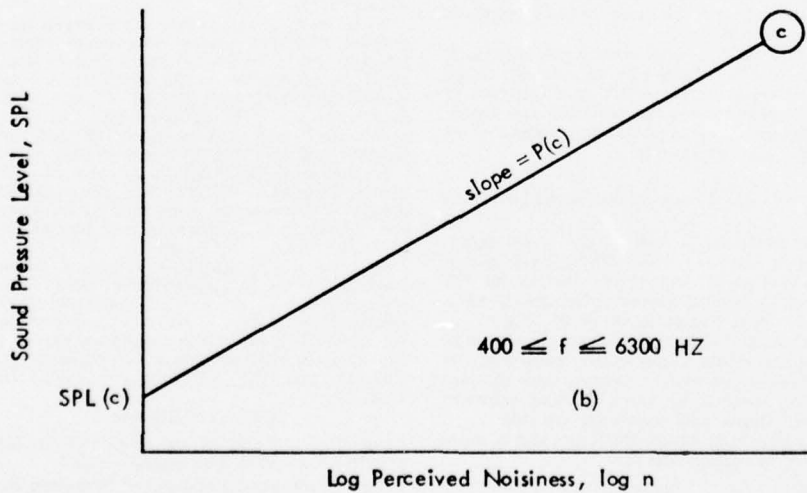
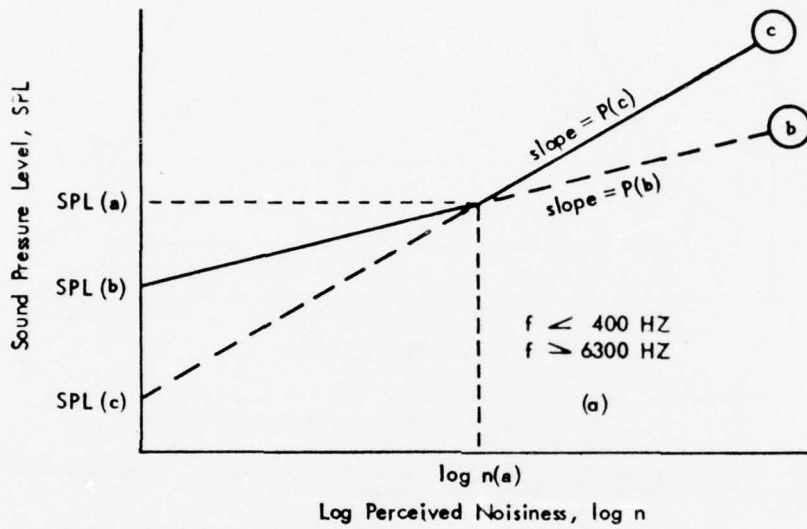

Figure B3. Sound Pressure Level as a Function of Noys.

1. the slopes of the straight lines, $p(b)$ and $p(c)$.
2. the intercepts of the lines on the SPL-axis, $SPL(b)$, and $SPL(c)$, and
3. the coordinates of the discontinuity, $SPL(a)$, and $\log n(a)$.

The equations are as follows:

- Case 1. Figure B3(a), $f < 400$ Hz.
 $f > 6300$ Hz.

$$SPL(a) = \frac{p(c)SPL(b) - p(b)SPL(c)}{p(c) - p(b)}$$

$$\log n(a) = \frac{SPL(c) - SPL(b)}{p(b) - p(c)}$$

- (a) $SPL(b) \leq SPL \leq SPL(a)$.

$$n = \text{ant} \frac{SPL - SPL(b)}{p(b)}$$

- (b) $SPL \geq SPL(a)$.

$$n = \text{ant} \frac{SPL - SPL(c)}{p(c)}$$

- (c) $0 \leq \log n \leq \log n(a)$.

$$SPL = p(b) \log n + SPL(b)$$

- (d) $\log n \geq \log n(a)$.

$$SPL = p(c) \log n + SPL(c)$$

- Case 2. Figure B3(b), $400 \leq f \leq 6300$ Hz.

- (a) $SPL \geq SPL(c)$.

$$n = \text{ant} \frac{SPL - SPL(c)}{p(c)}$$

- (b) $\log n \geq 0$.

$$SPL = p(c) \log n + SPL(c)$$

Let the reciprocals of the slopes be defined as,

$$M(b) = 1/p(b)$$

$$M(c) = 1/p(c)$$

Then the equations can be written,

- Case 1. Figure B3(a), $f < 400$ Hz.
 $f > 6300$ Hz.

$$SPL(a) = \frac{M(b)SPL(b) - M(c)SPL(c)}{M(b) - M(c)}$$

$$\log n(a) = \frac{M(b)M(c)[SPL(c) - SPL(b)]}{M(c) - M(b)}$$

- (a) $SPL(b) \leq SPL \leq SPL(a)$.

$$n = \text{ant} M(b)[SPL - SPL(b)]$$

- (b) $SPL \geq SPL(a)$.

$$n = \text{ant} M(c)[SPL - SPL(c)]$$

- (c) $0 \leq \log n \leq \log n(a)$.

$$SPL = \frac{\log n}{M(b)} + SPL(b)$$

- (d) $\log n \geq \log n(a)$.

$$SPL = \frac{\log n}{M(c)} + SPL(c)$$

- Case 2. Figure B3(b), $400 \leq f \leq 6300$ Hz.

- (a) $SPL \geq SPL(c)$.

$$n = \text{ant} M(c)[SPL - SPL(c)]$$

- (b) $\log n \geq 0$.

$$SPL = \frac{\log n}{M(c)} + SPL(c)$$

Table B4 lists the values of the important constants necessary to calculate sound

pressure level as a function of perceived noisiness.

APPENDIX C—NOISE LEVELS FOR SUBSONIC TRANSPORT CATEGORY AND TURBOJET POWERED AIRPLANES UNDER § 36.201

Section C36.1 *Noise measurement and evaluation.* Compliance with this appendix must be shown with noise levels measured and evaluated as prescribed, respectively, by Appendix A and Appendix B of this part, or under approved equivalent procedures.

Section C36.3 *Noise measuring points.* Compliance with the noise level standards of § 36.5 must be shown—

(a) For takeoff, at a point 3.5 nautical miles from the start of the takeoff roll on the extended centerline of the runway;

(b) For approach, at a point 1 nautical mile from the threshold on the extended centerline of the runway; and

(c) For the sideline, at the point, on a line parallel to and 0.25 nautical miles from the extended centerline of the runway, where the noise level after liftoff is greatest, except that, for airplanes powered by more than three turbojet engines, this distance must be 0.35 nautical miles.

Section C36.5 *Noise levels—(a) General.* Except as provided in paragraphs (b) and (c) of this section, it must be shown by flight test that the noise levels of the airplane, at the measuring points prescribed in § 36.3, do not exceed the following (with appropriate interpolation between weights):

(1) For approach and sideline, 108 EPNdB for maximum weights of 600,000 pounds or more, less 2 EPNdB per halving of the 600,000-pound maximum weight down to 102 EPNdB for maximum weights of 75,000 pounds and under.

(2) For takeoff, 108 EPNdB for maximum weights of 600,000 pounds or more, less 5 EPNdB per halving of the 600,000-pound maximum weight down to 93 EPNdB for maximum weights of 75,000 pounds and under.

(b) *Tradeoff.* The noise levels in paragraph (a) may be exceeded at one or two of the measuring points prescribed in § 36.3, if—

(1) The sum of the exceedances is not greater than 3 EPNdB;

(2) No exceedance is greater than 2 EPNdB; and

(3) The exceedances are completely offset by reductions at other required measuring points.

(c) *Prior applications.* For applications made before December 1, 1969, for airplanes powered by more than three turbojet engines with bypass ratios of two or more, the value prescribed in paragraph (b)(1) of this section may not exceed 5 EPNdB and the value prescribed in paragraph (b)(2) of this section may not exceed 3 EPNdB.

Section C36.7 *Takeoff test conditions.* (a) Except as provided in § 36.7(a)(2) of this Part, this section applies to all takeoffs conducted in showing compliance with this Part.

Band (i)	F HZ	M(b)	SPL (b) dB	SPL (a) dB	M(c)	SPL (c) dB
1	50	0.043478	64	91.0	0.030103	52
2	63	0.040570	60	85.9	"	51
3	80	0.036831	56	87.3	"	49
4	100	"	53	79.9	"	47
5	125	0.035336	51	79.8	"	46
6	160	0.033333	48	76.0	"	45
7	200	"	46	74.0	"	43
8	250	0.032051	44	74.9	"	42
9	315	0.030675	42	74.6	"	41
10	400	-	-	-	"	40
11	500	-	-	-	"	"
12	630	-	-	-	"	"
13	800	-	-	-	"	"
14	1000	-	-	-	"	"
15	1250	-	-	-	"	38
16	1600	-	-	-	0.029960	34
17	2000	-	-	-	"	32
18	2500	-	-	-	"	30
19	3150	-	-	-	"	29
20	4000	-	-	-	"	"
21	5000	-	-	-	"	30
22	6300	-	-	-	"	31
23	8000	0.042285	37	44.3	"	34
24	10000	"	41	50.7	"	37

Table B4. Constants for Mathematically Formulated NOY Values

(b) Takeoff power or thrust must be used from the start of the takeoff to the point at which an altitude of at least 1,000 feet above the runway is reached, except that, for airplanes powered by more than three turbojet engines, this altitude must not be less than 700 feet.

(c) Upon reaching the altitude specified in paragraph (b) of this section, the power or thrust may not be reduced below that power or thrust that will provide level flight with one engine inoperative, or below that power or thrust that will maintain a climb gradient of at least 4 percent, whichever power or thrust is greater.

(d) A speed of at least $V_2 + 10$ knots must be attained as soon as practicable after lift-off, and must be maintained throughout the takeoff noise test.

(e) A constant takeoff configuration, selected by the applicant, must be maintained throughout the takeoff noise test, except that the landing gear may be retracted.

Section C36.9 Approach test conditions.

(A) This section applies to all approaches conducted in showing compliance with this part.

(b) The airplane's configuration must be that used in showing compliance with the landing requirements in the airworthiness regulations constituting the type certification basis of the airplane. If more than one configuration is used in showing compliance with the landing requirements in the airworthiness regulations constituting the type certification basis of the airplane, the configuration that is most critical from a noise standpoint must be used.

(c) The approaches must be conducted with a steady glide angle of $3^\circ \pm 0.5^\circ$ and must be continued to a normal touchdown with no airframe configuration change.

(d) A steady approach speed of not less than $1.30 V_s + 10$ knots must be established and maintained over the approach measuring point.

(e) All engines must be operating at approximately the same power or thrust.

[Docket No. 9337, 34 FR 18364, Nov. 18, 1969, as amended by Amdt. 36-1, 34 FR 18816, Nov. 25, 1969; 34 FR 19025, Nov. 29, 1969; Amdt. No. 36-3, 39 FR 43842, Dec. 19, 1974; Amdt. No. 36-4, 40 FR 1035, Jan. 6, 1975]

APPENDIX D-E [RESERVED]

APPENDIX F—NOISE REQUIREMENTS FOR PROPELLER-DRIVEN SMALL AIRPLANES

PART A—GENERAL

Section F36.1 *Scope.* This appendix prescribes limiting noise levels, and procedures for measuring noise and correcting noise data, for the propeller driven small airplanes specified in § 36.1.

PART B—NOISE MEASUREMENT

Section F36.101 *General test conditions.*

(a) The test area must be relatively flat terrain having no excessive sound absorption characteristics such as those caused by thick, matted, or tall grass, by shrubs, or by wooded areas. No obstructions which significantly influence the sound field from the airplane may exist within a conical space above the measurement position, the cone being defined by an axis normal to the ground and by a half-angle 75 degrees from this axis.

(b) The tests must be carried out under the following conditions:

- (1) There may be no precipitation.
- (2) Relative humidity may not be higher than 90 percent or lower than 30 percent.
- (3) Ambient temperature may not be above 86 degrees F. or below 41 degrees F. at 33' above ground. If the measurement site is within 1 n.m. of an airport thermometer the airport reported temperature may be used.
- (4) Reported wind may not be above 10 knots at 33' above ground. If wind velocities of more than 4 knots are reported, the flight direction must be aligned to within ± 15 degrees of wind direction and flights with tail wind and head wind must be made in equal numbers. If the measurement site is within 1 n.m. of an airport anemometer, the airport reported wind may be used.
- (5) There may be no temperature inversion or anomalous wind condition that would significantly alter the noise level of the airplane when the noise is recorded at the required measuring point.
- (6) The flight test procedures, measuring equipment, and noise measurement procedures must be approved by the FAA.
- (7) Sound pressure level data for noise evaluation purposes must be obtained with acoustical equipment that complies with section F36.103 of this appendix.

Section F36.103 *Acoustical measurement system.* The acoustical measurement system must consist of approved equipment equivalent to the following:

- (a) A microphone system with frequency response compatible with measurement and analysis system accuracy as prescribed in section F36.105 of this appendix.
- (b) Tripods or similar microphone mountings that minimize interference with the sound being measured.

(c) Recording and reproducing equipment characteristics, frequency response, and dynamic range compatible with the response and accuracy requirements of section F36.105 of this appendix.

(d) Acoustic calibrators using sine wave or broadband noise of known sound pressure level. If broadband noise is used, the signal must be described in terms of its average and maximum root-mean-square (rms) value for nonoverload signal level.

Section F36.105 *Sensing, recording, and reproducing equipment.*

(a) The noise produced by the airplane must be recorded. A magnetic tape recorder is acceptable.

(b) The characteristics of the system must comply with the recommendations in International Electrotechnical Commission (IEC) Publication No. 179, dated 1973, concerning microphone and amplifier characteristics. The text and specifications of IEC Publication No. 179, dated 1973, and entitled "Precision Sound Level Meters" are incorporated by reference into this appendix and are made a part hereof as provided in 5 U.S.C. 552(a) and 1 CFR Part 51. This publication was published in 1965 and revised in 1973 by the Bureau Central de la Commission Electrotechnique Internationale in Geneva, Switzerland. It is available for purchase from the following sources: (1) Bureau Central de la Commission Electrotechnique Internationale, 1, rue de Varembe, Geneva, Switzerland; and (2) American National Standard Institute, 1430 Broadway, New York City, New York 10018. The matter is available for inspection at the following locations: (1) FAA Headquarters—DOT Branch Library, and Office of Environmental Quality, 800 Independence Avenue SW., Washington, D.C.; (2) FAA Regional Offices, in their respective cities; and (3) Office of the Federal Register, 1100 "L" Street NW., Washington, D.C.

(c) The response of the complete system to a sensibly plane progressive sinusoidal wave of constant amplitude must lie within the tolerance limits specified in IEC Publication No. 179, dated 1973, over the frequency range 45 to 11,200 Hz.

(d) If limitations of the dynamic range of the equipment make it necessary, high frequency pre-emphasis must be added to the recording channel with the converse de-emphasis on playback. The pre-emphasis must be applied such that the instantaneous recorded sound pressure level of the noise signal between 800 and 11,200 Hz does not vary more than 20 dB between the maximum and minimum one-third octave bands.

(e) If requested by the Administrator, the recorded noise signal must be read through an "A" filter with dynamic characteristics designated "slow," as defined in IEC Publication No. 179, dated 1973. The output signal from the filter must be fed to a rectify-

ing circuit with square law rectification, integrated with time constants for charge and discharge of about 1 second or 800 milliseconds.

(f) The equipment must be acoustically calibrated using facilities for acoustic free-field calibration and if analysis of the tape recording is requested by the Administrator, the analysis equipment shall be electronically calibrated by a method approved by the FAA.

(g) A windscreen must be employed with microphone during all measurements of aircraft noise when the wind speed is in excess of 6 knots.

Section F36.107 Noise measurement procedures.

(a) The microphones must be oriented in a known direction so that the maximum sound received arrives as nearly as possible in the direction for which the microphones are calibrated. The microphone sensing elements must be approximately 4' above ground.

(b) Immediately prior to and after each test, a recorded acoustic calibration of the system must be made in the field with an acoustic calibrator for the two purposes of checking system sensitivity and providing an acoustic reference level for the analysis of the sound level data.

(c) The ambient noise, including both acoustical background and electrical noise of the measurement systems, must be recorded and determined in the test area with the system gain set at levels that will be used for aircraft noise measurements. If aircraft sound pressure levels do not exceed the background sound pressure levels by at least 10 dB(A), approved corrections for the contribution of background sound pressure level to the observed sound pressure level must be applied.

Section F36.109 Data recording, reporting, and approval.

(a) Data representing physical measurements or corrections to measured data must be recorded in permanent form and appended to the record except that corrections to measurements for normal equipment response deviations need not be reported. All other corrections must be approved. Estimates must be made of the individual errors inherent in each of the operations employed in obtaining the final data.

(b) Measured and corrected sound pressure levels obtained with equipment conforming to the specifications described in section F36.105 of this appendix must be reported.

(c) The type of equipment used for measurement and analysis of all acoustic, air-

plane performance, and meteorological data must be reported.

(d) The following atmospheric data, measured immediately before, after, or during each test at the observation points prescribed in section F36.101 of this appendix must be reported:

- (1) Air temperature and relative humidity.
- (2) Maximum, minimum, and average wind velocities.

(e) Comments on local topography, ground cover, and events that might interfere with sound recordings must be reported.

(f) The following airplane information must be reported:

- (1) Type, model and serial numbers (if any) of airplanes, engines, and propellers.
- (2) Any modifications or nonstandard equipment likely to affect the noise characteristics of the airplane.
- (3) Maximum certificated takeoff weights.
- (4) Airspeed in knots for each overflight of the measuring point.
- (5) Engine performance in terms of revolutions per minute and other relevant parameters for each overflight.
- (6) Aircraft height in feet determined by a calibrated altimeter in the aircraft, approved photographic techniques, or approved tracking facilities.

(g) Aircraft speed and position and engine performance parameters must be recorded at an approved sampling rate sufficient to ensure compliance with the test procedures and conditions of this appendix.

Section F36.111 Flight procedures.

(a) Tests to demonstrate compliance with the noise level requirements of this appendix must include at least six level flights over the measuring station at a height of 1,000' \pm 30' and \pm 10 degrees from the zenith when passing overhead.

(b) Overflight must be performed at rated maximum continuous power, stabilized speed with propellers synchronized and with the airplane in the cruise configuration except that, if the speed at maximum continuous power would exceed the maximum speed authorized in level flight, accelerated flight is acceptable.

PART C—DATA CORRECTION

Section F36.201 Correction of data.

(a) Noise data obtained when the temperature is outside the range of 68 degrees F. \pm 9 degrees F., or the relative humidity is below 40 percent, must be corrected to 77 degrees F. and 70 percent relative humidity by a method approved by the FAA.

(b) The performance correction prescribed in paragraph (c) of this section must be used. It must be determined by the method described in this appendix, and must be added algebraically to the measured value. It is limited to 5 dB(A).

(c) The performance correction must be computed by using the following formula:

$$\Delta dB = 60 - 20 \log_{10} \left\{ (11,430 - D_{50}) \frac{R/C + 50}{V_v} \right\}$$

Where:

D_{50} —Takeoff distance to 50 feet at maximum certificated takeoff weight.

R/C —Certificated best rate of climb (fpm).

V_v —Speed for best rate of climb in the same units as rate of climb.

(d) When takeoff distance to 50' is not listed as approved performance information, the figures of 1375' for single-engine airplanes and 1600' for multi-engine airplanes must be used.

Section F36.203 *Validity of results.*

(a) The test results must produce an average dB(A) and its 90 percent confidence limits, the noise level being the arithmetic average of the corrected acoustical measurements for all valid test runs over the measuring point.

(b) The samples must be large enough to establish statistically a 90 percent confidence limit not to exceed ± 1.5 dB(A). No test result may be omitted from the averaging process, unless omission is approved by the FAA.

PART D—NOISE LIMITS

Section F36.301 *Aircraft noise limits.*

(a) Compliance with this section must be shown with noise data measured and corrected as prescribed in Parts B and C of this appendix.

(b) For airplanes for which application for a type certificate is made on or after October 10, 1973, the noise level must not exceed 68 dB(A) up to and including aircraft weights of 1,320 pounds (600 kg.). For weights greater than 1,320 pounds up to and including 3,630 pounds (1,650 kg.) the limit increases at the rate of 1 dB/165 pounds (1 dB/75 kg.) to 82 dB(A) at 3,630 pounds, after which it is constant at 82 dB(A) up to and including 12,500 pounds. However, airplanes produced under type certificates covered by this paragraph must also meet paragraph (d) of this section for the original issuance of standard airworthiness certificates or restricted category airworthiness certificates if those airplanes have not had flight time before the date specified in that paragraph.

(c) For airplanes for which application for a type certificate is made on or after January 1, 1975, the noise levels may not exceed the noise limit curve prescribed in paragraph (b) of this section, except that 80 dB(A) may not be exceeded at weights from and including 3,300 pounds to and including 12,500 pounds.

(d) For airplanes for which application is made for a standard airworthiness certificate or for a restricted category airworthiness certificate, and that have not had any flight time before January 1, 1980, the requirements of paragraph (c) of this section apply, regardless of date of application, to the original issuance of the certificate for that airplane.

(Title I of the National Environmental Policy Act of 1969 (42 U.S.C. 4321 et seq.); and EO 11514, Mar. 5, 1970.) [Docket No. 13243, 40 FR 1035, Jan. 6, 1975; 40 FR 6347, Feb. 11, 1975]

PART 37—TECHNICAL STANDARD ORDER AUTHORIZATIONS

Subpart A—General

- Sec.
- 37.1 Applicability.
 - 37.3 TSO authorization required.
 - 37.5 Application and issue.
 - 37.7 General rules governing holders of TSO authorizations.
 - 37.9 Approval for deviation.
 - 37.11 Design changes.
 - 37.13 Recordkeeping requirements.
 - 37.15 FAA inspection.
 - 37.17 Reporting of failures, malfunctions, and defects.
 - 37.19 Noncompliance.
 - 37.21 Transferability and duration.
 - 37.23 Incorporation by reference.

Subpart B—Technical Standard Orders

- 37.111 Cargo and baggage compartment smoke detection instruments—TSO-C1b.
- 37.112 Airspeed indicator (pitot static)—TSO-C2b.
- 37.113 Turn-and-slip indicator (TSO-C3b).
- 37.114 Bank and pitch instruments (indicating gyro-stabilized type) (gyroscopic horizon, attitude gyro)—TSO-C4c.
- 37.115 Direction instrument, non-magnetic, gyro-stabilized type (directional gyro)—TSO-C5c.
- 37.116 Direction instrument, magnetic (gyro-stabilized type)—TSO-C6c.
- 37.117 Direction instrument, magnetic, non-stabilized type (magnetic compass)—TSO-C7c.
- 37.118 Rate of climb indicator, pressure actuated (vertical speed indicator)—TSO-C8b.
- 37.119 Automatic pilots—TSO-C9c.
- 37.120 Aircraft, altimeter, pressure, actuated, sensitive type—TSO-C10b.
- 37.121 Fire detectors (thermal sensing and ionization sensing types)—TSO-C11d.

PROPOSED CHANGES

federal register

THURSDAY, OCTOBER 28, 1976



PART II:

DEPARTMENT OF TRANSPORTATION

**Federal Aviation
Administration**



AIRCRAFT NOISE MEASUREMENT AND EVALUATION SPECIFICATIONS

Proposed Rulemaking

**DEPARTMENT OF
TRANSPORTATION**

Federal Aviation Administration

[14 CFR Part 36]

[Docket No. 16221; Notice No. 76-21]

**AIRCRAFT NOISE MEASUREMENT AND
EVALUATION SPECIFICATIONS**

Proposed Rule Making

The Federal Aviation Administration is considering amending Part 36 of the Federal Aviation Regulations (14 CFR Part 36) to amend the procedures and standards for conducting noise type certification and acoustical change tests contained in Appendices A and B, to revise the form by which certain standards and procedures are incorporated by reference in Part 36, to redesignate certain provisions, and to provide a table of sections in each Part 36 appendix.

Interested persons are invited to participate in the making of the proposed rule by submitting such written data, views, or arguments as they may desire. Communications should identify the regulatory docket or notice number and be submitted in duplicate to: Federal Aviation Administration, Office of the Chief Counsel, Attention: Rules Docket, AGC-24, 800 Independence Avenue SW., Washington, D.C. 20591. All communications received on or before December 30, 1976, will be considered by the Administrator before taking action on the proposed rule. The proposals contained in this notice may be changed in the light of comments received. All comments submitted will be available, both before and after the closing date for comments, in the Rules Docket for examination by interested persons.

Any person may obtain a copy of this Notice of Proposed Rule Making (NPRM) by submitting a request to the Federal Aviation Administration, Office of Public Affairs, Attention: Public Information Center, APA-430, 800 Independence Avenue, SW., Washington, D.C. 20591, or by calling (202) 426-8058. Communications must identify the notice number of this NPRM. Persons interested in being placed on a mailing list for future NPRMs should also request a copy of Advisory Circular No. 11-2 which describes the application procedure.

BACKGROUND

Public Laws 90-411 and 92-574 were enacted to provide both present and future relief and protection to the public health and welfare from noise and sonic boom from civil aircraft. Under these Acts, the Administrator of the Federal Aviation Administration (FAA), after consultation with the Secretary of Transportation and the Administrator of the Environmental Protection Agency (EPA), is responsible for the adoption and amendment of rules which prescribe the necessary standards and regulations.

On November 3, 1969, the Federal Aviation Administration (FAA) adopted Part 36 of the Federal Aviation Regulations (FARs) entitled "Noise Standards: Aircraft Type Certification" (34 FR 18355;

November 18, 1969). FAR Part 36 contains several appendices in which the technical specifications for demonstrating compliance with Part 36 are prescribed. Appendices A and B of FAR Part 36 contain the specifications for conducting noise type certification tests and for evaluating the noise data in terms of Effective Perceived Noise Level (EPNL). These appendices have been modified slightly since their adoption in 1969. Appendix C of Part 36 prescribes noise level limits for new designs of subsonic transport category and turbojet powered aircraft for which an application for type certificate was made on or after January 1, 1967. As adopted, Part 36 also contained provisions for preventing the escalation of noise levels regarding growth or follow-on versions of those types of aircraft in production and for which application for a type certificate was made prior to January 1, 1967. Subsequent amendments added Appendix F prescribing noise standards for propeller-driven small airplanes and amended provisions regarding limited new production of old, nonconforming aircraft types. The FAA currently has under consideration several other proposals including standards for other types of aircraft (SSTs, helicopters, STOLs, etc.) and for various aircraft operations and airport noise standards. Some of these proposals were submitted to the FAA by the EPA under the Noise Control Act of 1972.

This notice of proposed rule making (NPRM) proposed to adopt specific substantive and clarifying amendments in the test and analysis instrumentation specification, calibration procedures, meteorological test conditions, and data correction procedures. Procedural changes in the calculation of EPNL are also proposed. The FAA proposes to make these amendments applicable to FAR Part 36 noise certification tests made after March 31, 1977, or 30 days after publication of the final amendment, whichever occurs later.

PROPOSED PROVISIONS

The proposed amendment to Appendix A involves a rather extensive revision which would be accomplished within the general framework of the current appendix. The FAA believes that some organizational revision is necessary to better accommodate the logical sequence of the expanded specifications. However, only relatively minor amendments are proposed for Appendix B. The FAA proposes editorial changes to redesignate certain provisions in Appendices A and B to conform with the format generally used throughout the FARs. To provide greater ease in identifying and citing the provisions in the appendices to Part 36, the FAA proposes to provide a "table of sections" at the beginning of the respective appendices and to designate the respective undesignated provisions of certain paragraphs and sections of Appendix B. Finally, the FAA proposes to amend Subpart A of Part 36 to add a new § 36.9 to prescribe the incorporations by reference contained in Part 36 under 5 U.S.C.

552(a) and 1 CFR Part 51 and to provide the required statements of identification and availability of incorporated published material. If this proposal is adopted, the present separate provisions in Appendices A, B, and F, which contain the required statements regarding incorporation by reference, would be revised.

The following discussion highlights portions of the proposed amendment to FAR Part 36:

A. PROPOSED REVISED APPENDIX A

1. *Noise certification test and measurement conditions (proposed § A36.1)*.— This section prescribes the conditions under which noise certification tests would be conducted and the measurement procedures that would be used to measure the noise made by the aircraft. These provisions would apply to tests conducted after March 31, 1977, or 30 days after publication of the final amendment, whichever occurs later.

The FAA proposes to prescribe in a single section all the requirements for an approved test site. While most of the provisions of this proposed section are already contained in Appendix A, it is felt that they should be grouped together. Additional requirements are proposed regarding an independent measurement of sideline noise if test site conditions make simultaneous takeoff and sideline measurements impractical.

A modification of the meteorological specification also is proposed. The temperature and relative humidity conditions under which testing is allowed would be amended to conform with proposed ICAO limits or to adopt a minor variation of the proposed ICAO limits. Basically, those ICAO limits would not allow testing when the sound attenuation rate in the one-third octave band centered at 8 kHz is greater than 10 dB/100 meters. However, the FAA is also considering adoption of a 12 dB/100 meters sound attenuation rate limit at the same frequency. This proposed alternative to the ICAO limit would be less restrictive than the ICAO proposal. Comments are specifically invited concerning the alternative proposals and the reasons why one sound attenuation rate would be preferable in the test meteorological specification. The ICAO proposed limits would also expand, under certain conditions, the permissible temperature range from the present 41-86 degrees F to 36-95 degrees F and the permissible relative humidity range from the present 30-90 percent to 20-95 percent. The FAA believes that amendments should be adopted that reflect current knowledge and state-of-the-art regarding calculation of atmospheric attenuation of sound energy. Based on its certification experience, the FAA believes that the current weather "window" is too restrictive of some combinations of temperatures and relative humidities while allowing some unsubstantiated corrections in other combinations. The FAA also proposes a new weather specification to require that the temperature and relative humidity to be within the "window" from the sur-

face measuring station to the altitude of the aircraft. More specific restrictions would be placed upon anomalous relative humidity and wind conditions. Each of these proposals grew out of FAA certification experiences and a need to provide regulatory guidance for use by the FAA regional authorities.

The FAA believes that to ensure the accuracy of noise level corrections under proposed § A36.11, the requirements for aircraft test weights should be amended to require the takeoff weight to be within five percent of the certification weight and the approach weight to exceed 90 percent of the maximum landing weight.

2. Measurement of aircraft noise received on the ground (proposed § A33.6).—The measurements prescribed in proposed § A36.3, like those in current § A36.2, provide the data for determining the one-third octave band noise produced by aircraft at specific observation stations, as a function of time. However, the instrumentation performance specifications have been significantly revised. These changes incorporate experience with actual certifications by both the FAA and ICAO over the past six years.

Three general guidelines were followed in the preparation of these proposals. First, the FAA intended to specify both systems and components that would give results with maximum accuracy and repeatability from test-to-test and site-to-site. Second, the proposals were prepared to avoid requiring instruments of any single brand name or manufacturer. Third, the specifications provide performance requirements that are generally measureable and verifiable in the field, rather than design parameters requiring sophisticated laboratory equipment or technical mathematical analyses. The FAA believes that these specifications would enhance compliance by taking greater advantage of readily obtainable FAA approved data and manufacturer's specifications.

In addition, this proposal provides more detailed specifications for microphones (and their accessories), tape recorders, analysis equipment, and calibrators. These revisions are primarily based upon experience with actual certifications and reports of some difficulty in understanding the current, more general language. While the proposals do not substantially change the application of procedures, the proposals would prescribe improved procedures and practices which should result in more uniform data. One of the new features of this proposal is the introduction of a new paragraph on calibration (proposed § A36.3(e)). This paragraph would require standardization of both calibration procedures and implementation schedules to provide more uniform and repeatable data by minimizing unaccounted for equipment variability and operator error.

3. Reporting and correcting measured data (proposed § A36.5).—Under the proposed rule, data representing physical measurements, or corrections to meas-

ured data (including corrections to measurements for equipment response deviations) must be recorded in permanent form and appended to the record. All corrections would be reported and subject to approval. The proposal permits certain estimates of the individual errors inherent in each of the operations employed in obtaining the final data.

The proposal clarifies the established procedure by expressly providing for a correction of any difference between the test engine rating and the reference engine rating. Additional standards are also provided for determining the validity of test results when more than one test site is used to demonstrate compliance.

4. Symbols and unit (proposed § A36.7).—Under the proposal, current section A36.4 would be redesignated but would remain substantively unchanged in content.

5. Atmospheric attenuation of sound (proposed § A36.9).—Under the current provisions of Appendix A (§ A36.5), the measured one-third octave band spectra are corrected to the reference-day conditions. Under the proposal (proposed § A36.9), this correction would be amended to better account for the differences in the atmospheric attenuation of sound between the test-day conditions and the reference-day conditions along the entire sound propagation path between the aircraft and the microphone.

FAA experience has shown that the measurement of, and correction for, non-reference meteorological conditions are exceedingly critical to obtaining consistent and repeatable test results. The FAA believes that more detailed meteorological data are needed and should be required. Specifically, current (test-time) meteorological observations of the temperature and relative humidity are needed over the whole sound propagation path from the aircraft to the surface. To avoid localized anomalous conditions that often occur near the ground, the surface meteorological measurements would continue to be made 10 meters above the surface.

Under the proposed § A36.9, if the atmospheric absorption coefficients vary over the sound propagation path by more than ± 0.3 dB/1,000 feet in the 3150 Hz one-third octave band from the attenuation rate defined by the surface meteorological measurements, applicants would be required to base atmospheric attenuation corrections upon the mean attenuation rate for each one-third octave over the entire length of the sound propagation path. However, the absence of inversions in both temperature and relative humidity during compliance testing would no longer be a limiting factor in the test sequence.

The FAA believes the proposed amendments would provide technologically adequate means for correcting noise data that are obtained under some atmospheric conditions under which testing is prohibited under the current Appendix A. Taken together, the revisions of §§ A36.1 and A36.9 would provide improved data repeatability and increase

the number of days during which tests may be conducted.

6. Detailed correction procedures (Proposed § 36.11).—If the noise certification test conditions do not conform to the noise certification reference conditions, appropriate positive correction must be made by the EPNL calculated from the measured data. Under the proposed § A36.11, the provisions of current § A36.6 would not be a significantly modified; however, the proposed rule would prescribe a procedure which allows corrections to be made for testing at a non-standard location.

For some aircraft which exhibit exceptionally low noise levels during take-off, the FAA believes that it may be necessary to bring the 3.5 nautical-mile measuring station to a point closer to the start of roll to assure recording the complete flyover noise history. The fly-over-noise/time history would include the 10 dB-down points from PNLTM both before and after the time of PNLTM, as required under current § B36.5 (proposed § B36.13). The EPNL value computed from these measurements must then be corrected to the value that would have occurred at the 3.5 nautical mile reference measuring point. Two procedures for making these corrections would be prescribed under the proposed amendment.

B. PROPOSED AMENDMENT OF APPENDIX B

1. Table B1 (in proposed § B36.3).—Perceived noisiness is expressed units of "noys" and is based upon the mathematical formulation given in § B36.13. Table B1 was included in current Appendix B to provide a ready reference for these applicants who elect not to calculate noy values from the formula. While the original table contains values down to 1.00 noy, lower values are sometimes required in the calculation of EPNL for low noise aircraft. Thus, the FAA believes Table B1 should be revised to provide those lower values. Such a revised table was prepared by the Society of Automotive Engineers and published in ARP 865. The International Standards Organization concurred with the revision (ISO/IC 43/SC1, revised March 3, 1975). ICAO currently has under consideration a similar revision. The FAA believes that Table B2 should also be amended to conform to the expanded Table B1.

2. Revision of pseudotone elimination procedures (Tables B2 and B3 in proposed §§ B36.3 and B36.5).—The FAA proposes to amend Table B2 to account for tone level differences less than 3.0 decibels in amplitude, since the current table provides no tone correction for these level difference values. Table B2 was originally constructed to avoid the possibility that false tones, "pseudotones," would be mistakenly identified during the data processing. These pseudotones result from interference patterns in the sound field near the earth's surface during an aircraft flyover. However, FAA noise certification experience with the pseudotone problem indicates that such precautions are no longer necessary. Since similar action has been

taken by ICAO, the FAA proposes to remove the 3.0 decibel lower limit on the level difference used to determine the tone correction. If the proposed amendment to Table B2 is adopted, the example contained in Table B3 would also require minor changes. Thus, this proposal also contemplates such amendments to Table B3.

A revised and expanded discussion on the methods for identifying and eliminating pseudotones is provided in proposed § B36.5 (m) and (n). The FAA believes these provisions are needed to clarify the prescribed methodology in the noise certification procedure.

3. Correction for spectral irregularities (Proposed § B36.5).—The FAA proposes to add two new paragraphs after the current last undesignated paragraph of current § B36.3 (proposed § B36.5). The first new paragraph would prescribe the exclusion of certain tones (resulting from ground-plane reflection) from calculations of corrections for spectral irregularities. The second paragraph would prescribe the evaluation of the five one-half second noise level samples around the initially calculated PNLTM. The FAA believes that occasionally the current ten-step procedure for calculating corrections for spectral irregularities yields incorrect values. The procedure, contained in current § B36.3, tends to undercompensate for tones occurring in frequencies near the crossover point between adjacent one-third octave filters. The FAA, ICAO, SAE and others have considered several proposed methods for overcoming this deficiency. After consideration of the side effects of the other methods, the FAA believes that the procedure proposed in this paragraph is the most appropriate and consistent.

C. EFFECTIVE DATE

The FAA proposes to make the proposals contained in this NPRM, applicable to each noise certification test conducted after March 31, 1977, or 30 days after publication of the final amendment, whichever occurs later.

In considering the date to propose for compliance with the amended specifications and procedures, the FAA believes it necessary to take into account that, if adopted, these new provisions could, in some cases, require additional instrumentation or revisions to existing data processing and analysis computer programs. Although the proposed revisions generally follow already established practices, the FAA is aware that some potential applicants may have had little or no recent noise certification experience. For these persons, the proposed changes may impose some burden. To ensure a reasonable period for these changes to be made, the FAA proposes that compliance with the revised Appendices A and B be required for tests conducted after March 31, 1977, or 30 days after publication of the final amendment, whichever occurs later.

D. INCORPORATIONS BY REFERENCE

While published materials which are incorporated by reference in Part 36 un-

der 5 U.S.C. 552(a) and 1 CFR Part 51 are currently prescribed in the substantive provisions of the respective appendices, the FAA proposes to add a new § 36.9 to Subpart A which would contain the required statements of identification and availability of these materials. By so doing, the FAA believes that the readability of the effected rules would be improved and the need for repetitive material would be kept to a minimum. The new § 36.9 would also serve as a technical bibliography and reference source for information regarding the incorporated materials. Under the proposal, the incorporating provision would contain only a reference identifying the material which is adopted as part of that rule. The FAA proposes to adopt the material incorporated by reference according to the date of the material specified in the reference and proposed § 36.9(c). Notice and public procedure will precede the adoption of any subsequent editions of incorporated materials.

E. EVALUATION OF IMPACTS OF THE PROPOSED RULE

The proposed rule primarily concerns test procedure amendments which would govern the specifics of conducting and reporting noise certification tests. It would neither raise nor lower the prescribed noise levels and would not require additional tests to be performed during the certification process. As a result, there would be little or no change in the noise levels of aircraft certificated to the proposed rule and there would be no anticipated change (either increasing or decreasing) in the amount of fuel used to conduct the tests or the amount of engine emissions produced during the tests. Since the proposed rule would require no additional limitations on their in-service operations or performance, no increase in fuel usage or emissions is anticipated to result from aircraft certificated to the proposed standard.

The proposed rule would be more stringent than the current rule in the requirement for noise certification test equipment, in the specification of the weather conditions, and in correction of test data to standard conditions. The increased stringency could, in some cases, increase the applicant's costs of noise type certification. However, the FAA believes that those costs could be offset by savings that would accrue from increased repeatability of the data. Current industry practice is to design and build aircraft using a tolerance below the actual noise level goals. The requirement for this tolerance arises from uncertainties in the repeatability of the data from tests under the current Part 36 procedures. Therefore, the FAA believes that by increasing the repeatability of the data, the proposed rule would contribute to reduced costs by eliminating unnecessary design features or performance limitations which would be introduced solely to meet the tolerance requirements.

The rule proposed in this notice has been reviewed in accordance with Executive Order 11821, entitled "Infla-

tionary Impact Statements" (39 FR 41501; November 29, 1974) and it has been determined that the preparation of an inflationary impact statement is not necessary.

F. AUTHORITY

This notice of proposed rule making is issued under authority of Secs. 313(a), 601, 603, and 611 of the Federal Aviation Act of 1958, as amended (49 U.S.C. 1354 (a), 1421, 1423, and 1431); sec. 6(e) of the Department of Transportation Act (49 U.S.C. 1655(e)); Title I of the National Environmental Policy Act of 1969 (42 U.S.C. 4321 et seq.), and Executive Order 11514, March 5, 1970.

In consideration of the foregoing, the Federal Aviation Administration proposes to amend Part 36 of the Federal Aviation Regulations (14 CFR Part 36) as follows:

Subpart A—General

1. Subpart A of Part 36 would be amended to add a new § 36.9 reading as follows:

§ 36.9 Incorporations by reference.

(a) *General.* This part prescribes certain standards and procedures which are not set forth in full text in the rule. Those standards and procedures are contained in published material which is reasonably available to the class of persons affected and has been approved for incorporation by reference by the Director of the Federal Register under 5 U.S.C. § 552 (a) and 1 CFR Part 51.

(b) *Incorporated matter.* (1) Each publication, or part of a publication, which is referenced but not set forth in full-text in this part and which is identified in paragraph (c) of this section is hereby incorporated by reference and made a part of Part 36 of this chapter with the approval of the Director of the Federal Register.

(2) Incorporated matter which is subject to subsequent change is incorporated by reference according to the specific reference and to the identification statement. Adoption of each subsequent change in incorporated matter will be made under Part 11 of this chapter and 1 CFR Part 51.

(c) *Identification statement.* The complete title or description which identifies each published matter incorporated by reference in this part is as follows:

(1) *International Electrotechnical Commission (IEC) Publications.* (i) Publication No. 179, entitled "Precision Sound Level Meters," dated 1973.

(ii) Publication No. 225, entitled "Octave, Half-Octave, Third Octave Band Filters Intended for the Analysis of Sounds and Vibrations," dated 1966.

(2) *Society of Automotive Engineers (SAE) Publications.* (i) (SAE) ARP 866A, entitled "Standard Values of Atmospheric Absorption as a Function of Temperature and Humidity for Use in Evaluating Aircraft Flyover Noise," dated March 15, 1975.

(ii) [Reserved]

(d) *Availability for purchase.* Published material incorporated by refer-

ence in this part may be purchased at the price established by the publisher or distributor at the following mailing addresses:

(1) *IEC publications.* (i) The Bureau Central de la Commission Electrotechnique Internationale, 1, rue de Varembe, Geneva, Switzerland.

(ii) American National Standard Institute, 1430 Broadway, New York City, New York 10018.

(2) *SAE publications.* Society of Automotive Engineers, Inc., 400 Commonwealth Drive, Warrentown, Pennsylvania 15096.

(c) *Availability for inspection.* A copy of each publication incorporated by reference in this part is available for public inspection at the following locations:

(1) FAA Office of Environmental Quality, Room 939B Headquarters, Federal Aviation Administration, 800 Independence Avenue, SW., Washington, D.C.

(2) Department of Transportation, Branch Library, Room 930, Headquarters, Federal Aviation Administration, 800 Independence Avenue, SW., Washington, D.C.

(3) The respective Regional Offices of the Federal Aviation Administration as follows:

(i) New England Regional Office, 12 New England Executive Park, Burlington, Massachusetts.

(ii) Eastern Regional Office, Federal Building, JFK International Airport, Jamaica, New York.

(iii) Southern Regional Office, 3400 Whipple Street, East Point, Georgia.

(iv) Great Lakes Regional Office, 2300 East Devon, Des Plaines, Illinois.

(v) Central Regional Office, 601 East Twelfth Street, Kansas City, Missouri.

(vi) Southwest Regional Office, 4400 Blue Mound Road, Fort Worth, Texas.

(vii) Rocky Mountain Regional Office, 10255 East 25th Avenue, Aurora, Colorado.

(viii) Northwest Regional Office, FAA Building, 9010 East Marginal Way South, King County International Airport (Boeing Field), Seattle, Washington.

(ix) Western Regional Office, 15000 Aviation Boulevard, Hawthorne, California.

(x) Alaskan Regional Office, 632 Sixth Avenue, Anchorage, Alaska.

(xi) Pacific-Asia Regional Office, 1833 Kolakoua Avenue, Honolulu, Hawaii.

(xii) European Regional Office, Tour Madou Building, 1, Place Madou, 1020 Brussels, Belgium.

(4) The Office of the Federal Register, Room 8401, 1100 "L" Street, NW., Washington, D.C.

APPENDIX A

2. The heading to Appendix A would be amended to add a table of sections and Appendix A would be revised to read as follows:

APPENDIX A—AIRCRAFT NOISE MEASUREMENT UNDER § 36.101

- Sec.
- A36.1 Noise certification test and measurement conditions.
 - A36.3 Measurement of aircraft noise received on the ground.
 - A36.5 Reporting and correcting measured data.
 - A36.7 Symbols and units.
 - A36.9 Atmospheric attenuation of sound.
 - A36.11 Detailed correction procedures.

§ A36.1 Noise certification test and measurement conditions.

(a) *General.* This section prescribes the conditions under which aircraft noise cer-

tification tests must be conducted and the measurement procedures that must be used to measure aircraft noise during each test conducted after March 31, 1977 (or the date 30 days after publication of the final amendment, whichever occurs later).

(b) *Test site requirements.* (1) Tests to show compliance with established aircraft noise certification levels must consist of a series of takeoffs and approaches during which measurements must be taken at noise measuring stations located at the measuring points prescribed in § C36.3 of Appendix C of this part.

(2) On each test takeoff, simultaneous measurements should be made at the sideline noise measuring stations on each side of the runway and also at the takeoff noise measuring station. However, if test site conditions make it impractical to simultaneously measure takeoff and sideline noise, and if each of the other sideline measurement requirements is met, independent measurements may be made of the sideline noise under simulated flight path techniques. If the reference flight path includes a power cutback before the maximum possible sideline noise level is developed, the reduced sideline noise level which is the maximum value developed by the simulated flight path technique must be the certificated sideline noise value.

(3) If the height of the ground at a noise measuring station differs from that of the nearest point on the runway by more than 20 feet, corrections must be made as prescribed in § A36.5(d) of this appendix.

(4) The location of each noise measuring station must be surrounded by relatively flat terrain having no excessive sound absorption characteristics, such as might be caused by thick, matted, or tall grass, shrubs, or wooded areas.

(5) An airport tower, or other facility, used to obtain required measurements of meteorological conditions at the test site must be approved in accordance with § A36.9(b) (1) of this appendix.

(6) During the period when the flyover noise/time record indicates the noise measurement is within 10 dB of PNLTM, no obstruction that significantly influences the sound field from the aircraft may exist:

(i) For a takeoff, approach, or sideline measurement station, within a conical space above the measuring position (the point on the ground vertically below the microphone), the cone being defined by an axis normal to the ground and by a half-angle 80 degrees from this axis; and

(ii) For a sideline noise measurement station, above the line of sight between the microphone and the aircraft.

(7) A minimum of four sideline noise measurement stations must be used to define the maximum sideline noise with respect to location and level as required by § C36.3 of Appendix C of this part. One of the microphones must be placed symmetrically with respect to one of the other microphones so that the maximum noise on either side of the aircraft can be determined analytically.

(c) *Weather restrictions.* The tests must be conducted under the following atmospheric conditions:

(1) No rain or other precipitation.

(2) Ambient air temperature between 36 degrees F and 95 degrees F (2.2 degrees C and 35 degrees C), inclusively, over that portion of the sound propagation path between the airplane and a point 10 meters above the ground at the noise measuring station.

(3) Relative humidity and ambient temperature over that portion of the sound propagation path between the airplane and a point 10 meters above the ground at the noise measuring station is such that the sound attenuation in the one-third octave band centered at 8 kHz is not greater than 10 dB/100 meters [alternative proposal: "12 dB/100 meters"] and the relative humidity is between 20 percent and 95 percent, inclusively.

(4) Airport reported wind velocity 10 meters above ground does not exceed 10 knots and the crosswind component does not exceed 5 knots.

(5) *No anomalous wind conditions* (including turbulence) which will significantly affect the noise level of the aircraft when the noise is recorded at each noise measuring station.

(d) *Aircraft testing procedures.*—(1) The aircraft testing procedures and noise measurements must be conducted and processed in an approved manner which yields the noise evaluation measure designated as Effective Perceived Noise Level (EPNL) in units of EPNdB, as prescribed in Appendix B of this part.

(2) The aircraft height and lateral position relative to the extended centerline of the runway must be determined by an FAA approved method which is independent of normal flight instrumentation, such as radar tracking, theodolite triangulation, laser trajectory, or photographic scaling techniques.

(3) The aircraft position along the flight path must be related to the noise recorded at the noise measuring stations by means of synchronizing signals at an approved sampling rate. The position of the aircraft must be automatically recorded relative to the runway during the entire time period in which the recorded signal is within 10 dB of PNLTM. Measuring and sampling equipment must be approved by the FAA.

(4) Each takeoff test must meet the conditions of § C36.7 of Appendix C of this part.

(5) If a takeoff test series is conducted at weights other than the maximum takeoff weight for which noise certification is requested, the following additional requirements apply:

(i) At least one takeoff test must be conducted at a weight at, or above, the maximum certification weight.

(ii) Each test weight must be within ± 5 percent of the maximum certification weight.

(iii) The weight correction required under § A36.11 of this appendix may not exceed 2.0 EPNdB. (Approved data must be used to determine the variation of EPNL with weight for takeoff test conditions.)

(6) Each approach test must be conducted with the aircraft stabilized and following a 3.0 degree ± 0.5 degree approach angle and must meet the requirements of § C36.9 of Appendix C of this part.

(7) If approach test series is conducted at weights other than the maximum landing weight for which certification is requested, the following additional requirements apply:

(i) At least one approach test must be conducted at a weight at, or above, the maximum landing weight.

(ii) Each test weight must exceed 90 percent of the maximum landing weight.

(iii) The weight correction required under § 36.11 of this appendix may not exceed 1.0 EPNdB. (Approved data must be used to determine the variation of EPNL with weight for approach test conditions.)

(8) Aircraft performance data sufficient to make the correction required under § A36.5 of this appendix must be automatically recorded at an approved sampling rate using FAA approved equipment.

§ A36.3 Measurement of aircraft noise received on the ground. (a) *General.*—(1) The measurements prescribed in this section provide the data for determining the one-third octave band noise produced by aircraft during testing procedures, at specific noise measuring stations, as a function of time.

(2) Sound pressure level data for aircraft noise certification purposes must be obtained with approved acoustical equipment and measurement practices.

(3) Paragraphs (b), (c), and (d) of this section prescribe the required equipment specifications. Paragraphs (e) and (f) pre-

APPENDIX B

TRACKING ACCURACY CALCULATIONS

The procedures used to calculate the maximum tracking errors shown in Figures 4.4 through 4.9 are given in this appendix. These figures illustrate the uncertainty in the determination of the aircraft position for one geometry (radar location with respect to runway and flight path) for radar tracking systems with several different angular and range accuracies. The positional uncertainty is translated into a slant range uncertainty and converted to dB. This slant range error represents the worst case error that can occur in the corrections applied to the acoustical data when correcting the acoustical measurements to compensate for the difference between 3° and the measured flight track. The slant range is the distance from the aircraft to an observation point on the ground. An angle of 45° was chosen between the ground and the slant range line to approximate the point of maximum noise.

The maximum error in height, cross track position, along track position, and slant range due to the angular and range resolution accuracy of the tracking hardware was computed using trigonometry. These calculations were carried out using a computer program in three dimensions. The procedure used will be illustrated using a two dimensional model shown in Figure B.1. In this simplified model the tracking system is located at the point of touchdown, T. The aircraft is following a nominal 3° glide slope. The tracking system has a range accuracy of ± 30 feet as illustrated by the line ce and an angular accuracy of ± 1 mil as illustrated by ϵ .

The first step in determining the maximum error at one distance out (TN') is to determine the nominal position for a true 3° glide slope at this distance. Then the tolerance in

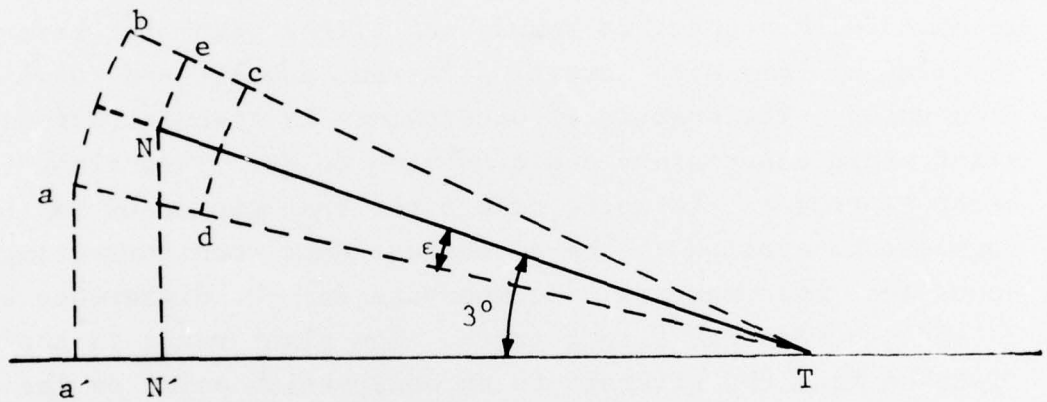

(Not to scale)

FIGURE B.1 TWO DIMENSIONAL TRACKING GEOMETRY FOR POSITION ERROR CALCULATIONS

angle (± 1 mil) and range (± 30 feet) are added to the nominal values. In this two dimensional example the points a, b, c, and d are generated representing the various possible combinations of tolerance and therefore the worst case limits of the combined tolerances. These limit points are projected onto the new coordinate system to determine the error in the new coordinate system. In the example the maximum error along the track would be represented by the line a'N' as a', the projection of a, is the furthest away from the projection of N. This procedure would be repeated for the other planes.

The slant range error converted to dB represent the uncertainty in sound level that is attributable to the spreading loss correction. This is again a positional uncertainty so the same position limits, a, b, c, and d, as shown in Figure B.1 are applicable. Figure B.2 shows the relationship of these limit points and the corresponding slant range lines. The slant range line $M_N N$ is the slant range distance calculated for the position N' out from the end of the runway. The slant range error in dB for location error position b is:

$$dB = 20 \log \frac{M_b b}{M_N N}$$

This error is computed for each location, a, b, c, and d, and the largest error is the maximum slant range error.

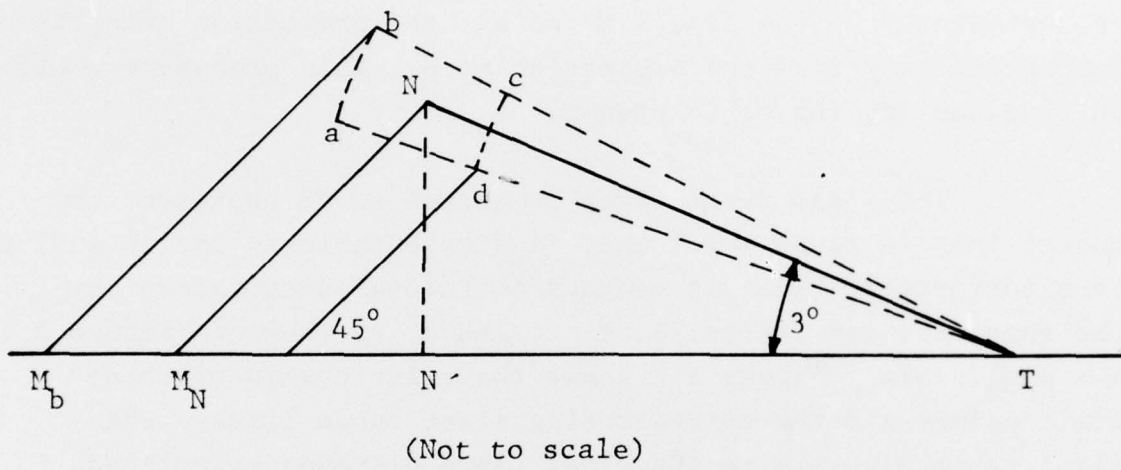

FIGURE B.2 TRACKING GEOMETRY FOR SLANT RANGE ERROR CALCULATIONS