

AD-A042 803

HUMAN FACTORS RESEARCH INC GOLETA CALIF
PERIPHERAL VISION TRAINING FOR MOTOR VEHICLE DRIVERS. (U)
JUN 77 R T HENNESSY, R E NEWTON
1767-F

F/G 5/9

UNCLASSIFIED

DOT-HS-5-01204

NL

1 of 3
ADA042803



ADA 042803

h

3

PERIPHERAL VISION TRAINING FOR MOTOR VEHICLE DRIVERS

ROBERT T. HENNESSY
ROBERT E. NEWTON

HUMAN FACTORS RESEARCH, INCORPORATED
6780 CORTONA DRIVE, GOLETA, CALIFORNIA 93017



JUNE 1977
FINAL REPORT

*Code 2.3
0.5*

DDC
RECEIVED
AUG 10 1977
APV A

AD No. _____
DDC FILE COPY

DOCUMENT IS AVAILABLE TO THE U.S. PUBLIC THROUGH THE
NATIONAL TECHNICAL INFORMATION SERVICE,
SPRINGFIELD, VIRGINIA 22161

PREPARED FOR
U.S. DEPARTMENT OF TRANSPORTATION
NATIONAL HIGHWAY TRAFFIC SAFETY ADMINISTRATION
WASHINGTON, D.C. 20590

NOTICES

THIS DOCUMENT IS DISSEMINATED UNDER THE SPONSORSHIP OF THE DEPARTMENT OF TRANSPORTATION IN THE INTEREST OF INFORMATION EXCHANGE. THE UNITED STATES GOVERNMENT ASSUMES NO LIABILITY FOR THE CONTENTS OR THE USE THEREOF.

THE UNITED STATES GOVERNMENT DOES NOT ENDORSE PRODUCTS OR MANUFACTURERS. TRADE OR MANUFACTURER'S NAMES APPEAR HEREIN SOLELY BECAUSE THEY ARE CONSIDERED ESSENTIAL TO THE OBJECT OF THIS REPORT.

Technical Report Documentation Page

1. Report No.		2. Government Accession No.		3. Recipient's Catalog No. 11	
4. Title and Subtitle PERIPHERAL VISION TRAINING FOR MOTOR VEHICLE DRIVERS				5. Report Date June 1977	
				6. Performing Organization Code	
7. Author(s) Robert T. Hennessy and Robert E. Newton				8. Performing Organization Report No. 14 1767-F	
9. Performing Organization Name and Address Human Factors Research, Inc. 6780 Cortona Drive Goleta, California 93017				10. Work Unit No. (TRAIS)	
				11. Contract or Grant No. 15 DOT-HS-5-01204	
12. Sponsoring Agency Name and Address U.S. Department of Transportation National Highway Traffic Safety Administration 400 Seventh Street, S.W. Washington, D.C. 20590				13. Type of Report and Period Covered 9 Final Report 6/17/75 through 2/28/77	
				14. Sponsoring Agency Code 17 June 75 - 26 Feb 77	
15. Supplementary Notes					
16. Abstract <p>The purpose of this study was to determine if the peripheral vision of motor vehicle drivers can be improved through training. The specific goals were: (1) to develop an indoor training technique which would produce substantial improvement in one or more peripheral vision functions, and (2) to determine if the improvements realized through indoor training would transfer to both similar and different peripheral vision functions in the driving context.</p> <p>Three experiments were performed. Since peripheral vision declines with age, the majority of the subjects participating in these experiments were 60 years of age or older. During Experiment I the training regimen was too strenuous for the subjects so that no useful results, other than methodological ones, were obtained. Experiment II consisted of 10 days of training on vehicular silhouette recognition in the peripheral field of view. The experimental subjects showed significant and substantial improvements in their ability to recognize vehicular silhouettes. A control group showed no improvement. Experiment III replicated Experiment II with the addition of testing while driving on the highway. A control group was administered the same tests as the experimental subjects. The experimental subjects again showed substantial improvements in peripheral vision performance in the training context. They also showed significant improvement on the silhouette recognition and motion detection tests conducted during driving. Remarkably, however, the control subjects exhibited nearly as much improvement on the same tests. The difference in improvement between the groups was not statistically significant; thus, there was no evidence that improvement of peripheral vision due to indoor training transfers to the driving context. However, the rapid improvement in peripheral vision performance during driving tests by both experimental and control subjects is testimony to the fact that this is a readily trainable function.</p>					
17. Key Words driver vision peripheral vision visual training			18. Distribution Statement This document is available to the U.S. public through the National Technical Information Service, Springfield, Virginia 22161		
19. Security Classif. (of this report) Unclassified		20. Security Classif. (of this page) Unclassified		21. No. of Pages 241	22. Price

402 185

JB

TABLE OF CONTENTS

<u>Chapter</u>		<u>Page</u>
I	INTRODUCTION	1
	PROBLEM BACKGROUND.	1
	LITERATURE REVIEW	2
	<i>PERIPHERAL VISION.</i>	2
	<i>Measurement and Specification of</i> <i>Peripheral Vision</i>	3
	<i>Factors Affecting Peripheral Vision</i> <i>Performance</i>	5
	<i>PERIPHERAL VISION IN DRIVING</i>	10
	<i>TRAINING OF PERIPHERAL VISION</i>	12
II	EXPERIMENTS.	21
	RESEARCH APPROACH	21
	<i>PERIPHERAL VISION FUNCTIONS.</i>	21
	<i>TRAINING PROCEDURE</i>	22
	<i>CRITERION TESTS.</i>	23
	<i>POPULATION OF SUBJECTS</i>	24
	EXPERIMENT I.	25
	<i>APPARATUS.</i>	25
	<i>Training Apparatus.</i>	25
	<i>Testing Apparatus</i>	28
	<i>PROCEDURE.</i>	32
	<i>TESTING.</i>	32
	<i>TRAINING</i>	34
	<i>SUBJECTS</i>	35
	<i>RESULTS.</i>	36
	<i>DISCUSSION</i>	39
	<i>CONCLUSIONS.</i>	42
	EXPERIMENT II	44
	<i>APPARATUS.</i>	45
	<i>Training.</i>	45
	<i>Testing</i>	46

DIST.	APPROV. AND OR SPECIAL	COPIES
A	23	

TABLE OF CONTENTS (CONTINUED)

<u>Chapter</u>		<u>Page</u>
II	PROCEDURE	49
	<i>Training</i>	49
	<i>Mark I Vision Testing</i>	53
	<i>Kinetic Perimetry Testing - Experimental Subjects</i>	54
	<i>Kinetic Perimetry and Recognition Testing - Control Subjects</i>	55
	<i>Retention Testing</i>	56
	SUBJECTS	57
	RESULTS	57
	<i>Training Task - Experimental Subjects</i>	57
	<i>Training Task Retention - Experimental Subjects</i>	60
	<i>Kinetic Perimetry Test - Experimental Subjects</i>	65
	<i>Test Results - Control Subjects</i>	68
	<i>Mark I Tests</i>	74
	DISCUSSION	80
	CONCLUSIONS	87
	EXPERIMENT III	88
	APPARATUS	89
	<i>Testing</i>	89
	<i>Training</i>	96
	PROCEDURE	96
	<i>Testing</i>	96
	<i>Motion Detection Tests</i>	97
	<i>Use of Staircase Method</i>	97
	<i>Silhouette Recognition Test</i>	100
	<i>Driving and Testing</i>	101
	<i>Low Contrast Detection Test</i>	102
	<i>Kinetic Perimetry Test and Training</i>	103
	SUBJECTS	103

TABLE OF CONTENTS (CONTINUED)

<u>Chapter</u>		<u>Page</u>
II	<i>RESULTS.</i>	103
	<i>Ortho-Rater Low Contrast Detection.</i>	103
	<i>Single- and Dual-Silhouette Recognition</i>	109
	<i>Kinetic Perimetry</i>	109
	<i>Silhouette Recognition During Driving</i>	114
	<i>Motion Detection During Driving</i>	118
	<i>Influence of Weather on Driving Test Results</i>	122
	<i>DISCUSSION</i>	125
	<i>Training Tasks.</i>	125
	<i>Low Contrast Disc Detection</i>	126
	<i>Silhouette Recognition During Driving</i>	126
	<i>Motion Detection During Driving</i>	128
	<i>Individual Motion Detection Data.</i>	129
	<i>Motion Detection Testing Methodology</i>	131
	<i>Transfer of Training.</i>	133
	<i>Wearing of Glasses.</i>	134
	<i>CONCLUSIONS.</i>	134
III	<i>SUMMARY AND GENERAL DISCUSSION</i>	137
IV	<i>FINAL CONCLUSIONS AND RECOMMENDATIONS.</i>	145
V	<i>REFERENCES</i>	147
APPENDIX A	<i>- DESCRIPTION OF MARK I INTEGRATED VISION TESTER TESTS.</i>	A-1
APPENDIX B	<i>- GRAPHS OF MOTION DETECTION TEST PERFORMANCE FOR INDIVIDUAL SUBJECTS IN EXPERIMENT III</i>	B-1

LIST OF FIGURES

<u>Figure</u>		<u>Page</u>
1	Training apparatus in side view (upper illustration) and plan view (lower illustration), shown in relation to the subject's position.	27
2	Testing apparatus in side view (upper illustration) and plan view (lower illustration), shown in relation to the subject's position.	29
3	Silhouette targets used for testing in Experiments I and II (top illustration) and training in Experiments II and III (bottom illustration)	31
4	Dual-projector training apparatus in side view (upper illustration) and plan view (lower illustration), shown in relation to the subject's position.	47
5	Luminance curve for training projectors	48
6	Mean training performance with large (5.0°) single and dual silhouettes for all experimental subjects	59
7	Mean training performance with large (5.0°) single and dual silhouettes for the seven experimental subjects tested for retention (N = 7)	61
8-10	Training performance with large (5.0°) single and dual silhouettes for individual experimental subjects 1, 2, and 3	62
11-13	Training performance with large (5.0°) single and dual silhouettes for individual experimental subjects 4, 5, and 6	63
14-16	Training performance with large (5.0°) single and dual silhouettes for individual experimental subjects 7, 8, and 9	64
17	Kinetic perimetry performance with small (2.4°) single silhouettes for all experimental subjects (N = 9)	66

LIST OF FIGURES (Continued)

<u>Figure</u>		<u>Page</u>
18	Kinetic perimetry performance with small (2.4°) single silhouettes for the seven experimental subjects tested for retention (N = 7)	67
19-21	Kinetic perimetry performance with small (2.4°) single silhouettes for individual experimental subjects 1, 2, and 3	69
22-24	Kinetic perimetry performance with small (2.4°) single silhouettes for individual experimental subjects 4, 5, and 6	70
25-27	Kinetic perimetry performance with small (2.4°) single silhouettes for individual experimental subjects 7, 8, and 9	71
28	Performance changes from initial to final testing with large (5.0°) single silhouettes for experimental and control subjects .	72
29	Performance changes from initial to final testing with large (5.0°) dual silhouettes for experimental and control subjects	73
30	Kinetic perimetry performance changes from initial to final testing with small (2.4°) single silhouettes for experimental and control subjects.	75
31	Testing apparatus, in side view (upper illustration) and plan view (lower illustration), shown in relation to the subject's position.	90
32	Schematic representation of the motion testing apparatus depicting the stimulus array (upper left and right) and plan and side views (lower left and right, respectively) of the perimeter.	94
33	Mean training performance with large (5.0°) single and dual silhouettes for the experimental subjects	106
34-36	Training performance with large (5.0°) single and dual silhouettes for individual experimental subjects 1, 2, and 3	107

LIST OF FIGURES (Continued)

<u>Figure</u>	<u>Page</u>
37-39	Training performance with large (5.0°) single and dual silhouettes for individual experimental subjects 4, 5, and 6 108
40 & 41	Training performance with large (5.0°) single and dual silhouettes for individual experimental subjects 7 and 8 109
42	Kinetic perimetry performance with small (2.4°) single silhouettes for the experimental subjects 110
43-45	Kinetic perimetry performance with small (2.4°) single silhouettes for individual experimental subjects 1, 2, and 3 111
48	Kinetic perimetry performance with small (2.4°) single silhouettes for individual experimental subjects 4, 5, and 6 112
49 & 50	Kinetic perimetry performance with small (2.4°) single silhouettes for individual experimental subjects 7 and 8 113
51	Silhouette recognition test performance for initial and final testing for experimental and control subjects 116
52	Motion detection performance (30° stimulus) of experimental and control subjects during driving. 120
53	Motion detection performance (45° stimulus) of experimental and control subjects during driving. 120

LIST OF TABLES

<u>Table</u>		<u>Page</u>
1	TRAINING DATA SUMMARY FOR TRAINING TECHNIQUE #1	40
2	SUMMARY OF EXPERIMENT II TESTING AND TRAINING SCHEDULE	50
3	CHARACTERISTICS OF INDIVIDUALS WHO PARTICIPATED IN EXPERIMENT II.	58
4	ACUITY SCORES FROM MARK I VISION TESTER FOR EXPERIMENTAL AND CONTROL SUBJECTS.	76
5	MARK I VISION TEST SCORES - EXPERIMENTAL SUBJECTS	77
6	MARK I VISION TEST SCORES - CONTROL SUBJECTS .	78
7	SUMMARY OF EXPERIMENT III TESTING AND TRAINING SCHEDULE	95
8	SUMMARY OF TESTING SCHEDULE IN VAN	96
9	SCREENING DATA, ORTHO-RATER AND LOW CONTRAST PERIMETRY SCORES	104
10	MEAN % CORRECT RECOGNITION PERFORMANCE ON VAN SILHOUETTE TESTS FOR INITIAL AND FINAL TESTING FOR EXPERIMENTAL AND CONTROL SUBJECTS.	115
11	MEAN % CORRECT RECOGNITION ON THE VAN SILHOUETTE TESTS FOR THE 4 DAYS OF TESTING . .	117
12	MEAN VAN MOTION TESTING PERFORMANCE FOR EXPERIMENTAL AND CONTROL SUBJECTS WITH VAN STATIONARY AND MOVING.	119
13	ABBREVIATED SUMMARY TABLE OF ANALYSIS OF VARIANCE FOR MOTION DETECTION TEST DATA. . . .	121
14	MEANS AND STANDARD DEVIATIONS ASSOCIATED WITH SIGNIFICANT F VALUES FOR MOTION TEST DATA. . .	123
15	WEATHER CONDITIONS DURING VAN TESTING OF MOTION DETECTION.	125

ACKNOWLEDGMENTS

The authors gratefully acknowledge the contributions of the following individuals whose assistance and cooperation materially aided this study.

Mr. John O. Merritt, Human Factors Research, Inc., who participated in all phases of this study and devised the motion test used in the van.

Dr. Harold Booher, Navy Personnel Research and Development Center, the Technical Monitor during the major portion of the study, who provided a great many useful suggestions for the conduct of the research and worked closely with the authors during the entire course of the work.

Mr. Gene Kelley, formerly with Human Factors Research, Inc., whose substantial efforts in the development and construction of the training and testing equipment greatly facilitated the conduct of the research.

Dr. Robert L. Henderson, National Highway Traffic Safety Administration, whose interest in and review of the work as it progressed was of great value to the authors.

Professor Herschel W. Leibowitz, Pennsylvania State University, who provided many useful comments and references at the beginning of the study.

Dr. John A. Cegalis, Syracuse University, whose advice and comments were valuable to the authors.

EXECUTIVE SUMMARY

The general purpose of the work reported here was to develop and evaluate training techniques for improving peripheral vision of motor vehicle drivers. Recent studies by NHTSA have established the importance of several new functional visual tests for the screening of motor vehicle drivers. These tests tend to emphasize dynamic perceptual factors rather than static sensory factors. Several of these new tests involve peripheral vision. Individuals who fail a peripheral vision test cannot be helped by corrective lenses and the only viable alternative for improving deficient peripheral vision is through training. Historically the literature has indicated that the prognosis for improvement of peripheral vision through training is good.

The work reported here consisted of three phases roughly corresponding to three experiments. During the first phase, an attempt was made to define criteria for deficient peripheral vision. In the absence of standardized methods for measuring peripheral vision and the consequent lack of adequate data, deficient peripheral vision could not be defined. However, since peripheral vision declines with age, it was decided to principally use older drivers as subjects. For the last two experiments, all subjects were 52 years of age or older. Experiment I was preliminary in nature and involved testing of vehicular silhouette recognition and motion detection while driving a research vehicle. A 5-day training course on the recognition of low contrast projected discs was also given to five experimental subjects. A number of procedural problems experienced during this experiment limited the usefulness of its findings, except from a methodological point of view.

Experiment II concentrated on development of an adequate peripheral vision training technique. The training method chosen was recognition of vehicular silhouettes presented

peripherally either singly or in pairs. Training was conducted for 1 hour a day for 10 days. Additionally, the nine experimental subjects participating in this experiment were administered a battery of tests using the Mark I Integrated Vision Tester prior to the training course and at the end of the training course. Before and after each training session a kinetic perimetry test was also administered to each subject. Retention tests were conducted 2 months after the end of the training course. All subjects showed significant and substantial improvement in their performance on the training task and on the kinetic perimetry test. The retention test indicated almost complete savings of the improvement in peripheral performance. There were no significant improvements on any of the Mark I Integrated Vision Tester tests. Control subjects administered the same tests as the experimental subjects before and after an interval equal to the length of the training course showed no improvement on any of the measures. No testing of peripheral vision while driving was conducted during this experiment.

Experiment III used the same training technique which proved to be successful in Experiment II. Eight experimental subjects who received training were tested on the recognition of vehicular silhouettes and motion detection while driving a research van on the highway before and after the training course. In addition, eight control subjects were administered the driving tests before and after an interval equal to the length of the training course. The experimental group showed substantial improvements in performance in the training context. They also showed significant improvement on the silhouette recognition and motion detection tests conducted while driving the van. Remarkably, however, control subjects who received no indoor training exhibited nearly as much improvement in peripheral vision while driving as the experimental subjects. No evidence was found to support the contention that improvement of peripheral vision due to indoor training successfully transfers to the driving context. The improvement in

performance on the driving tests by both the experimental and control subjects is attributed to practice effects on the tests themselves. The results are important, however, because they confirm that the use of peripheral vision by drivers can be improved through training.

I. INTRODUCTION

PROBLEM BACKGROUND

Recent studies sponsored by the National Highway Traffic Safety Administration (NHTSA) have demonstrated the relationships between several new visual screening tests and accident involvement (Henderson & Burg, 1973, 1974). These tests were derived from a human factors analysis of the visual functions involved in driving and tend to emphasize dynamic perceptual factors rather than static sensory factors. Eventually some or all of these new vision tests may be recommended to the states for inclusion in their testing programs for driver licensing.

Anticipating the implementation of these new visual tests, there is some concern about what correctional recourse will be available to individuals who fail to meet the minimum performance standards on one or more of the tests. The conventional visual screening test currently used by most states emphasizes static visual acuity performance. Individuals with low acuity can usually go to an ophthalmologist or an optometrist and be fitted with corrective lenses that will enable them to pass the acuity test.

Several of the new tests proposed for further driver vision screening programs involve peripheral vision. It is highly unlikely that corrective lenses would be of any help to an individual who has failed to pass a peripheral vision test. The only apparent possibility for improving the peripheral vision performance of these individuals is through training. Several reports in the vision literature suggest that the prognosis for the improvement of peripheral vision through training is good. It is not known, however, what type of peripheral vision training would be suitable for motor vehicle drivers or whether training conducted in an indoor setting would successfully transfer to the driving environment.

The purpose of this study was to determine if the peripheral vision of motor vehicle drivers can be improved through training. The specific goals were:

- (1) To develop an indoor training technique which would produce substantial improvement in one or more peripheral vision functions, and
- (2) To determine if the improvements realized through such training would transfer to both similar and different peripheral vision functions in a driving context.

LITERATURE REVIEW

PERIPHERAL VISION

The visual field is that area that can be seen with both eyes open and the head and eyes stationary. Peripheral vision encompasses the entire visual field except for the region that is within 1° of the line of sight. The region between 1° and 5° is the paracentral or near-peripheral field; beyond 5° from the center of vision is the far-peripheral field.

The monocular visual field, measured from the point of fixation, extends 60° toward the nose, 70° down, 90° toward the temple, and 50° up. The full binocular field covers 180° horizontally and the central 120° can be seen by both eyes.

Peripheral vision provides continuity to our visual world, alerts us to objects and activity remote from our direction of gaze, and provides information for fixational eye movements. For the driver it provides velocity and positioning information (Henderson & Burg, 1974) and alerts him to the approach of people, vehicles, and other objects adjacent to his path of travel.

Peripheral vision is superior to central vision only when all objects in the visual field have a luminance of approximately .016 cd/m² or less. This luminance level is referred to as the photopic threshold because the central visual receptors, the cones, do not operate below this level. When

luminance is greater than the photopic threshold, the general case even for driving at night, central vision is always superior to peripheral vision.

Under photopic conditions peripheral visual performance, however measured, always decreases from the center of vision to the limits of the visual field. Depending on the measure used, the decrease in performance can be relatively rapid or gradual. For example, peripheral acuity, the ability to resolve detail, decreases rapidly compared to the ability to detect motion.¹ Peripheral visual performance does not decrease at the same rate in all directions (meridional angles) from the center of vision. Performance is relatively better in the temporal and inferior (lower) visual field than in the nasal and superior (upper) visual field (Borish, 1970).

Measurement and Specification of Peripheral Vision

Data on peripheral visual performance is generally presented in two ways: (1) by specifying the performance value at one or more retinal loci, or (2) by specifying the isopter of constant performance for a given stimulus value. In the first case the retinal loci are chosen for testing and the stimulus value is changed and performance measured. In the second case the stimulus value is held constant and the retinal loci tested are changed until the performance criterion is reached. By testing around the entire visual field a map, the isopter, can be drawn which connects points of equal performance over the entire or some significant portion of the visual field.

If a significant amount of data is collected, the form of presentation can be translated from one method of presentation to the other. It is important to note, however, that peripheral

¹The reader can demonstrate this to himself by holding his hand with fingers outstretched about 20 in. from the side of his head while looking straight ahead. The separation of the fingers cannot be seen peripherally, but any slight wiggling of the fingers is easily detected.

visual performance data presented in isopters reflects the common conceptualization of the peripheral field as having a certain size. In fact, the "size" of the peripheral field is directly dependent upon what the stimulus values are, the conditions of testing, and the performance criteria.

In the beginning of this section values were given for the extent of the visual field. It is now apparent that the size specification is meaningless unless more is said about how the size of the visual field was determined. What is commonly meant by the size of the peripheral field is the isopter for the detection of very bright light entering the pupil of the eye. In other words, it is the absolute size of the visual field for the detection of light, limited only by the dioptics of the eye and the physiological extent of the retina, the layer of photosensitive receptors at the back of the eye. Since detection of light is the most primitive function of the visual system and all other measures of vision depend upon it, the ability to detect light defines the extreme limits of peripheral vision. Any other measure will necessarily be equal to or, as is more often the case, less than this size.

Conditions of peripheral vision testing have a great influence on the performance measurements obtained. Some of the most important stimulus factors include background luminance and its uniformity, target luminance, color, size, shape, duration of presentation, and in the case of moving targets, the rate of movement. Because of the variety of combinations of stimulus factors that have been used and, in some cases, the failure to report all relevant testing parameters, the comparison of the results of one study to another is extremely difficult. Generally, reviews of peripheral vision cite several representative studies rather than attempting to combine data obtained under different conditions. The lack of standardization of conditions for the testing of peripheral vision has led the National Academy of Sciences to publish a report recommending standardized conditions and procedures for visual field testing (National Academy of Sciences, 1975).

These recommendations are very primitive and the principal recommendation is that, at the very least, the conditions of testing be accurately reported.

It is not the intent of this review to present a detailed survey of the published data on thresholds and field sizes for various peripheral vision functions. Several excellent reviews are available which discuss and synthesize the available data on peripheral vision performance (Aulhorn & Harms, 1972; Borish, 1970; Graham, 1965; Haines, 1975; LeGrand, 1967; Low, 1950; National Academy of Sciences, 1975). However, the following review of the factors of age, oxygen deprivation, alcohol, stressors, task demands, and intrinsic variability in relation to measurable changes in peripheral vision is included to emphasize the lability of such visual functions. In addition, these factors were felt to have implications for the testing and training procedures used in the present research.

Factors Affecting Peripheral Vision Performance

Besides variation in the conditions of testing, peripheral vision performance is markedly affected by the age of the individual, his physiological state, mental health, physiological and psychological stress, multitask performance, and attention. Each of these factors is discussed below.

Age. It is well known that vision declines with age (Botwinick, 1970, 1973; Chown & Heron, 1965; McFarland, 1956). Generally, the decline in vision is attributed to a reduction in the amount of light reaching the retina due to yellowing and clouding of the ocular media and a reduction in the average size of the pupil. Neuronal degeneration is also a possible cause of the decline of vision with age. Using several measures of peripheral vision, Wolf (1962, 1971) demonstrated that after age 60 peripheral performance declines substantially.

Burg (1968) conducted the most extensive study of vision and driving ever performed, involving over 17,000 California drivers. He used a test apparatus consisting of a 30 cm radius arc located around the visual horizontal meridian with white

circular spots subtending 45.8 minutes located at 5° intervals around the perimeter. The perimeter was illuminated by a 50 watt bulb above the center radius of the arc 69 cm from the perimeter. Target illumination was reported to be 7.5 foot candles. Target luminance was not given. Burg showed that the horizontal extent of the visual field decreases from about 175° at age 20 to about 150° at age 70. These data represent the most substantial documentation of the relative change in field size with age thus far obtained.

Oxygen Deprivation and Alcohol. Oxygen deprivation has been shown to adversely affect peripheral vision and reaction time to peripheral stimuli (Kobrick, 1972, 1974; Kobrick & Appleton, 1971; Kobrick & Dusek, 1970; McFarland, Evans, & Halperin, 1941; Wolf, 1962). Generally the effects of oxygen deprivation or hypoxia are produced by reducing atmospheric pressure to simulate altitudes up to 17,000 ft. above sea level. It is interesting to note that in one study (Kobrick, 1972) the presence of a central reaction time task resulted in lower reaction times to peripheral stimuli than when the central task was absent. The author hypothesized that the presence of the central task helped to maintain arousal or alertness and offset the drowsiness which usually occurs during oxygen deprivation.

Moskowitz and Sharma (1974) have shown that alcohol can affect the detection of peripheral lights but only when a central task must be performed simultaneously with a peripheral task. The authors conclude that alcohol interferes with central information processing or attention rather than peripheral sensory mechanisms.

Stessors and Task Demands. Many forms of stressors, both physiological and psychological, and task demands can produce changes in the size of the visual field. The most extreme form of reduction of peripheral vision due to stress occurs in psychopathic hysteria. A number of studies (Baird, 1906; Eames, 1947; Hurst, Oxon, & Symns, 1919; Reeder, 1944; Yasuna, 1946) have documented reduction of the visual field in the absence

of any physiological abnormalities. In extreme cases, the peripheral field can shrink to less than 20° in diameter and be highly distorted in form. Most of the reported cases of hysterical "tunnel vision" have involved military personnel who were to be or had been exposed to combat conditions. The size of the field for these individuals was rarely stable. More frequently the field would show changes during the actual course of testing. The suggestion of relief from combat duty almost invariably resulted in a disappearance of symptoms. These cases highlight the fact that peripheral vision or deficiencies in peripheral vision cannot be considered to be strictly ocular phenomena. Functional peripheral vision involves the entire eye-brain system. Reduction and variability of the size of the visual fields under less extreme circumstances have been reported in a number of studies.

Weltman, Smith, and Egstrom (1971) had 15 male subjects perform a central acuity task and a peripheral light detection task during what they thought to be a simulated 60 ft. dive in a pressure chamber. There was no actual pressure change. A 15-man control group performed the same tasks outside of the pressure chamber. Peripheral detection was severely degraded in the chamber group and it was concluded that perceptual narrowing had been demonstrated as a result of the psychological stress associated with the exposure to the "dangerous" pressure chamber. Zahn and Haines (1971) showed that increasing the luminance of a central search task from 8.5 to 6,800 fL caused an increase in the detection time and the number of errors for peripherally presented test lights. Bursill (1956) reported a decrease in the accuracy of detection of peripheral signals under adverse thermal conditions when there was also a high perceptual load on a central tracking task. Several studies have shown that peripheral performance decreases or the size of the functional visual field decreases when a central task loading is increased (Bahrick, Fitts, & Rankin, 1952; Gasson & Peters, 1965; Leibowitz & Appelle, 1969; Webster & Haslerud, 1964). Hockey (1970a,

1970b) performed a study on the effects of dual task performance in the presence of noise. As in other studies, the peripheral signals were detected less often in the presence of noise. He concluded that the loud noise produced arousal which increased the selectivity of attention. In a follow-on study (Hockey, 1970b), he adjusted the number of peripheral signals presented so that the total number of central and peripheral signals were seen equally often. Under these circumstances there was no differential effect of noise for central and peripheral signals. He concluded that the selectivity effect is a function of task priorities and not of physical location. Other studies (Cornsweet, 1969; Reeves & Bergum, 1972) tend to support the view that arousal increases attentional selectivity but go on to show that when the relevance of peripheral cues is increased there are fewer errors and faster reaction times to peripheral signals.

Emphasizing the importance of peripheral signals, either through a reward structure or through the nature of the experimental design, can produce increased performance and a concomitant decrement of performance on a central task (Bodis-Wollner, 1973; Putz & Rothe, 1974). These studies tend to confirm that people have the capability to direct their attention within the visual field independently of the fixation of the eyes.

Engel (1971), in a study of peripheral conspicuity, also confirmed that a given probability of detection of a target against a confusing background occurs further out in the visual field when the subject is aware of the approximate location of the target and maintains a central fixation. The target and background were presented for a short duration of 75 msec. Engel makes a distinction between the field size within which an object can be noticed when its approximate location is known (the visibility area) and the field within which an object can be noticed when its location is unknown (the conspicuity area). The conspicuity area is always

smaller than the visibility area. Grindley and Townsend (1968) have found that directed attention increases peripheral performance only when other "competing" stimuli are present within the field of view.

All of these studies tend to support the principle that the peripheral visual function is dependent upon central as well as sensory processes and the ability to detect peripheral stimuli can be degraded or enhanced depending upon the arousal state of the observer, the relevance of the peripheral cues, and their probability of occurrence. Sanders (1963) in summarizing the results of a series of experiments on information processing refers to the functional or effective visual field which shrinks or expands depending on the perceptual load and nature of the task. Mackworth (1965) alludes to a similar process in stating that visual noise causes (functional) tunnel vision. Mackworth emphasizes the adverse effects of stress on peripheral detection performance. Some of the studies mentioned above have shown the functional visual field can be increased as well as decreased depending on the situation. All of this work, however, demonstrates that there is a great deal of variability in the utilization of peripherally presented information. While information presented to the central visual field has a very high probability of being effective, the corresponding effectiveness of peripherally presented stimuli depends upon both the nature of the task and the condition of the observer.

Intrinsic Variability. Changes in sensitivity due to task demands are not the only source of variability in peripheral vision. Rather, it appears that variability occurs even in the absence of any secondary task requirements. Low (1946) reported that variability seems to be an inherent characteristic of peripheral vision. The scotomata mentioned in the following quote from Low are blind spots in the visual field.

During the progress of the investigation here reported which represents well over 1,000

hours of perimetry, no permanent scotomata were observed. All appeared to be temporary, existing for very short periods of time. It is unlikely that these could be attributed to glare since they appeared under scotopic conditions as well as in the photopic testing. Fatigue seems to be a more reasonable explanation for the scotomata although the fatigue must be understood to be essentially regional, restricted to small retinal areas, since the scotomata have appeared in all conditions of freshness and fatigue of the subjects as well as being temporary. (p. 578)

Ronchi (1970) and Ronchi and Viliani (1973) studied the variability of the perception of lights blinking every 2 seconds over a period of 40 minutes. The test lights were presented at several locations in the visual field along the temporal meridian ranging from the fovea or center of vision to 60° peripherally. They plotted their data in terms of the probability of detection for 30-second epochs over the 40-minute test period. The data are characterized by a general decline in the probability of detection over the period but with many wide fluctuations in the probability of detection from epoch to epoch. The same tests were conducted with corrected peripheral astigmatism and under cycloplegic paralyzation of the accommodative and pupillary muscles. Essentially the same results were obtained. It was concluded that the fluctuations were due to central neuronal factors rather than physiological dioptrics.

PERIPHERAL VISION IN DRIVING

Hills (1975) in the introduction of a recent article on vision and accidents said:

It has proved surprisingly difficult to establish beyond doubt a link between poor visual performance and high accident rates. The more intractable problem of justifying the cut-off scores used as vision standards has hardly been tackled at all. Thus, at present there is virtually no scientific basis to any of the world's various driver vision standards. However, there is little doubt that vision, or visual perception, is an important factor in vehicle driving. (p. 1)

Peripheral vision is one of those visual functions which is generally regarded as important to driving but the nature of its importance and a uniform standard for field size has never been established.

Kite and King (1961) reviewed the various physiological and physical factors which limit the visual field of the motor vehicle driver. The physiological reductions in the size of the peripheral field are generally those due to diseases of the eye, optic nerve, or brain and cause concentric reduction of the field size, loss of one-half or one-quarter of the field, or are limited to scotomata of various sizes within the visual field. Physiological losses are usually absolute and rarely characterized by a partial reduction in sensitivity. Physical factors limiting the peripheral field of the driver include various parts of the vehicle and spectacle frames.

Various opinions on the size of the visual field required for driving have been expressed. Danielson (1957) interviewed a number of people who have been driving for several years with visual fields of approximately 40°. He concluded that driving under these conditions is neither unduly dangerous nor is any significant feeling of deficiency experienced by the driver, except for looking to the rear. Richards (1967) believes that a driver with a total horizontal field of 50° can drive safely provided he is aware of his limitation. However, Allen (1969) stated that when the limits of the visual field dropped below 140° driving should not be permitted. An American Optical Company report (1969) cited by Henderson and Burg (1974) indicates that state standards for minimum allowable binocular field size range from 90° to 150° with no common standard for measurement.

Peripheral vision is generally regarded as having a primary function of directing fixation to some point of interest in the visual field. It is obvious, however, that information is being extracted from the peripheral field that is not

directly related to fixation control. Allen (1969) has pointed out that the reaction time and dwell time of fixations consume .2 to .5 seconds, and it is clearly impossible to use central vision to scan the entire field of view during driving.

Henderson and Burg (1974) developed the concept of Useful Peripheral Vision. This refers to the ability to extract information from the driving environment necessary for vehicle control, navigation, and the avoidance of hazards without requiring direct fixation of some specific point in the visual field. They have emphasized the importance of functional visual tests that take into account the complex perceptual tasks involved in driving rather than confining visual testing to fundamental sensory abilities. To this end, they developed an integrated vision tester which included several functional tests related to driving as well as standard clinical tests of vision. They correlated the results of the tests performed on 669 drivers with their accident records and showed that some of these functional tests were indeed related to accident involvement.

Burg (1967, 1968) has shown that dynamic visual acuity, the ability to resolve detail in a moving target, is a good visual predictor of accident involvement. A test of dynamic visual acuity is not a standard clinical vision test but has an obvious functional relationship to driving. Further development of functional visual tests including those for peripheral vision, may result in even better visual predictors of accident involvement. The types of tests for peripheral vision that are felt to be most useful at this time are peripheral angular movement, peripheral movement in depth, and a test that requires the subject to detect a peripheral object, fixate it, and resolve detail within a short space of time (Henderson, Burg, & Brazelton, 1971; Henderson & Burg, 1974; Shinar, 1977).

TRAINING OF PERIPHERAL VISION

It has been known for at least 100 years that peripheral vision can be improved through training (Dobrowolsky & Gaine,

1875). In this early study, described by Low (1950), subjects were trained for 1 hour daily for 3-1/2 months. Improvement was noticeable during the first 6 weeks with little improvement thereafter. The results were expressed in terms of the size of the visual field within which a test object of a given size could be recognized. By the end of training, the field diameter had approximately doubled. Franz and Morgan (1933) studied the effects of three types of training on the recognition of forms presented 8° from the fixation point. The forms were presented tachistoscopically for 1 second. One group of subjects identified forms by reference to a set of sample cards; the second group was asked to reproduce the form they had seen; and the third group was given exposure to the forms without feedback. The first two groups showed significant improvement in their ability to recognize forms. The third group showed very little improvement. The authors also pre- and posttested other areas in the visual field and reported improvements in these untrained locations.

During the 1940s, Low performed several studies of peripheral vision, many of which involved the effects of practice or training on peripheral vision. In one of the early studies (1943), he tested the peripheral Landolt ring acuity of 100 subjects. He found no correlation between peripheral and central acuity. He also found that the results from test to test of the same subject were highly variable and that the second eye tested always did better than the first. This latter finding suggested that exposure to testing conditions (practice) caused improvements in the second eye tested.

Low (1946) investigated this phenomenon further. Forty-three subjects were trained using practice without feedback for an unspecified length of time. The average improvement in peripheral acuity for the group was 334%. Large individual differences were noted, however. The best subject improved 1,200% of his starting score and the worst subject improved 200%. These percentage changes in acuity were not reported in terms of absolute measures of pre- and posttraining acuity

levels. It was noted that the effects of training appeared to be general. For example, scotopic acuity also showed substantial improvements although no training occurred under these conditions. The subjects also reported improvement in peripheral vision in their everyday life. Low (1946) summarized these reports by saying:

The most arresting feature of the training results was the changes experienced by subjects in their awareness of peripheral stimuli outside of the laboratory. It was not supposed that the improved acuity would be sufficient to produce subjective awareness elsewhere, but student discussions of new experiences in peripheral perception in everyday life become so persistent toward the middle of the course that a questionnaire on these experiences was submitted to them. Data were gathered on typical, everyday experiences such as walking, driving, sports, reading, etc. Forty-one of 42 subjects had noticed differences. Thirty were certain that these differences were intrusive, reaching the consciousness without the subject's having been thinking about the training course when they occurred. One hundred and three situations involving change were reported and all but two of these were interpreted to be helpful rather than detrimental to the behavior of the subject. (p. 580)

Low (1947a) attempted to improve peripheral acuity for moving Landolt rings using 50 subjects. The Landolt rings were presented for 1 second and had a movement rate of 15° per second. Since the main purpose of the study was to obtain motion acuity data, the training consisted of practice (only), i.e., exposure to the test situation with no feedback. No improvement with practice was found. This contrasts with the results of his previous study using static targets. Low concluded that the brief exposure of 1 second was responsible for the failure to obtain improvement. A second study (Low, 1947b) was devoted to determining the effect of exposure duration on peripheral acuity. Exposure durations of 1, .2, .04, and .01 second were used. As would be expected, peripheral acuity declined with shorter exposure times. Again Low found no tendency for improvement with practice with short

exposure times. Low concluded "that the subject must have time to work out his impression of the stimulus position if improvement through practice is to be expected."

At about the same time that Low was doing his work, Renshaw (1945) reported that tachistoscopic training with strings of numbers also caused enlargements of the visual field for the recognition of numbers, letters, and geometric forms. Renshaw stated that the form fields for 30 subjects showed conspicuous enlargement due to the tachistoscopic training. No data were presented to support the statement other than isopter drawings for two sample cases.

Saugstad and Lie (1964) performed a study on the improvement of peripheral visual acuity through training. In their procedure only one retinal locus, 55° on the temporal horizontal meridian, was tested. Landolt rings were exposed for .2 second. After determining the acuity for eight subjects, they were divided into two groups of four and received 13 practice sessions spaced over 5 weeks. The practice sessions for the two groups differed in that the first group was trained with the Landolt ring on which they had answered correctly approximately 50% of the time in the test situation. The second group was trained with the Landolt ring on which they had answered correctly approximately 90% of the time during testing. The general results were that the first group which was trained with the smaller and more difficult Landolt ring showed significant improvement on the posttest. The second group, trained with the easier Landolt ring, showed very little improvement. The authors concluded that, contrary to Low's findings, considerable improvement in acuity can be obtained under conditions of short exposure of the test object if the test object is small enough to be just discriminable. The results were interpreted in terms of shifts in the maximum momentary level of attention from the central to the peripheral visual field.

The first study which employed feedback during peripheral training was evidently that performed by Abernethy and

Leibowitz (1971). In their experiment absolute luminance thresholds were obtained for the horizontal meridian under binocular viewing conditions. The loci tests ranged from 90° on the left to 90° on the right. Two groups of five subjects each were used. All subjects were required to perform a central task while the peripheral thresholds were being determined. The central task consisted of pressing a button each time a steady fixation light went off. The level of difficulty of the central task was different for the two groups. For the first group the fixation light was extinguished at a rate of 28 times per minute; for the second group it was extinguished 59 times per minute. Luminance thresholds were obtained during five sessions on different days. During the first session, no feedback was given to the subject about his detection of the peripheral lights. On the second through fifth sessions, both visual and auditory feedback were provided. The subject was told if he missed a light on the left or right, and then the luminance of the stimulus was increased until it became visible.

A significant improvement was found on each successive session except there was no significant difference in luminance threshold between the fourth and fifth session. The group having the more difficult central task showed the highest initial peripheral luminance threshold and the greatest improvement. The final threshold levels obtained during the fifth session were almost identical for the two groups. The authors concluded that when there is competition between a central and a peripheral task the central task is favored and that this effect is probably the result of competition for attention.

Johnson and Leibowitz (1974) studied the influence of practice, feedback, and refractive error on peripheral motion thresholds. Using four subjects, motion thresholds for the horizontal meridian ranging from 0° to 80° peripherally in 10° steps were determined. A constant stimulus duration of 1 second was used. Each subject was tested for four sessions

on consecutive days. Each session lasted 1 to 1-1/2 hours. No feedback was given during these sessions. The results indicated a general increase in motion sensitivity beyond 20° of excentricity. Major changes occurred between the first and second and second and third sessions. Beyond the third session little improvement occurred.

The refractive error at each excentricity tested for each of the subjects was then determined optometrically and corrected for that location with ophthalmic lenses. Four more sessions for determining movement thresholds, alternately with and without refractive correction, in a counterbalanced order, were conducted. The refractive correction resulted in a halving of the motion threshold at the excentricities beyond 30°. Another interesting finding was that the motion thresholds with correction were almost identical for the four subjects, although without correction there were marked individual differences.

A third phase of the study, using the same subjects, involved determination of motion thresholds during eight more sessions, alternately with and without refractive correction and with feedback provided to the subject during all sessions. The feedback improved movement detection in the periphery when refractive error was not corrected but had no effect when refractive error was corrected. Even after improvement from feedback, correction of refractive error still produced significantly lower peripheral movement thresholds than without correction.

The fact that feedback improved peripheral movement detection only when refractive error was not corrected suggests that feedback served to improve the interpretation of a degraded image. Also, the motion thresholds with feedback were much lower than with practice alone, although the design of the experiment did not allow separation of these two factors.

Retention tests conducted 1 month and 3 months after the end of the training sessions indicated considerable savings.

The retention tests yielded thresholds which were approximately halfway between the initial threshold on the first session and the best performance obtained after feedback training. This study was the first to show that sensitivity to peripheral motion can be improved through training. The authors discuss the possibility that learning under practice and feedback conditions are of two different types. They suggest that under practice the subject may learn to shift attention to the periphery momentarily. Improvement under feedback conditions may occur as a result of the subject learning to extract relevant cues from a blurred image.

A recent study by Sailor (1973) investigated the effect of practice on expansion of the peripheral field. Field size was defined as the location along the left and right horizontal meridians where a white test object of unspecified size could be detected as it was moved in from the extreme periphery toward the center of the field. Two groups of 12 subjects each were used. The experimental group was given a 10-minute practice period twice weekly for 6 weeks. The practice consisted of detecting the white stimulus object. The control group received no practice but conducted the training for the experimental subjects. Both groups of subjects were also enrolled in a speed reading course. No other details of the methodology were reported.

The field size was measured for both groups at the end of the 6-week practice period. There was a significant increase in the diameter of the visual field for both the experimental and control subjects. There were no significant differences between the two groups. Sailor suggests that the increase in the peripheral field size for the control subjects may be due to greater attention on the posttest or to the training received in the speed reading course.

The results of all these studies support the contention that peripheral vision can be improved through training. There are conflicting conclusions, however. Low (1946, 1947b, 1950) repeatedly emphasized that training with short-duration

stimulus presentations is ineffective. However, several of the studies reviewed here found large improvements with short-duration stimulus presentations.

In the earlier studies there was little speculation over the nature of the improvement in peripheral vision. The more recent studies usually suggest that control of attention is involved in the improvement. Several of the studies reported improvements in peripheral vision in untrained areas such as the other eye or untrained locations in the peripheral field. Low reported anecdotely that the improvement in peripheral vision was general and not specific to the type of task on which the subjects were trained. None of the studies, however, provides any substantive data on transfer of training between two peripheral tasks such as acuity and motion detection. It should be noted that except for the studies by Abernethy and Leibowitz (1971), and Johnson and Leibowitz (1974), training consisted of practice with no feedback.

Because of the great variation in the training methodologies used in the studies reviewed, it is difficult to draw any generalizations about what constitutes an efficient procedure for training peripheral vision. The duration of training sessions varied from 10 minutes to 1.5 hours and the length of the training course varied from a few sessions to 6 weeks. Improvement in peripheral vision may result from even minimal exposure to a training or testing situation. Low (1943) found that during peripheral vision testing the second eye tested was always better, i.e., exhibited greater acuity at a comparable retinal locus than the first eye tested. This suggests that less than 20 minutes of practice can cause significant improvement in peripheral vision.

II. EXPERIMENTS

RESEARCH APPROACH

The primary objective of this research was to determine if peripheral vision, useful for driving, could be improved through training. A secondary objective was to determine what type of training was necessary to produce improved peripheral vision during driving. The development of the research program to meet these objectives was based on four considerations: the peripheral vision functions to be trained, the nature of the training procedure, the type of criterion tests to be used to evaluate the transfer of training to the driving environment, and the population of subjects to be trained.

PERIPHERAL VISION FUNCTIONS

The selection of the peripheral vision functions to be trained was based on two assumptions. First, they should be reasonably related to driving and, second, the simplest peripheral vision function that is trainable should be used. The choice of peripheral visual functions that met the first assumption was almost arbitrary. Henderson and Burg (1974) had concluded that peripheral detection and recognition of objects, and sensitivity to motion, were significantly related to safe driving. These are fairly broad definitions of peripheral vision functions but more specific definitions were unavailable in the literature. The second assumption, that the peripheral vision function selected for training should be as simple as possible, arose because of the possibility that improvements of a specific peripheral vision function through training may generalize to other functions.

Several of the articles discussed in the literature review suggested that improvements in peripheral vision through training are due to changes in the allocation of attention to

peripheral objects and events rather than the improvement of a specific visual skill. If improvements in a simple peripheral vision function do in fact generalize, it has important practical implications; peripheral vision screening tests possibly could be simple with no requirement to determine a specific deficiency, and training equipment and procedures could also be relatively simple. Conversely, if improvements through training of peripheral vision do not generalize, then diagnostic techniques would have to be more complex and a variety of training techniques developed.

It was decided therefore that the initial peripheral function to be trained would be object detection. If simple detection training did not produce significant improvements in other peripheral vision functions, then successive training procedures would involve apparently more complex peripheral vision processes such as object recognition and motion detection.

TRAINING PROCEDURE

Since the first training course would be based on simple detection of a peripheral object, the training procedure could also be fairly simple. Prior studies on training of peripheral vision had shown that practice alone is sufficient to cause improvements, but the addition of performance feedback results in greater improvement and possibly more rapid learning. A highly structured training situation would be experimentally helpful because it would allow an exact specification of the training protocol. For this reason it was decided that the feedback given to the subject when he failed to detect the target object would be a short report that the target had been presented, where it was presented, and a brief additional presentation of the target. Saugstad and Lie (1964) found that peripheral acuity improved only if the subject received training with near threshold targets. It was therefore decided that for the initial detection training a low contrast circular spot would be used as the detection target and

presented at peripheral angles where detection performance was approximately 50%. As performance improved during the course of training, the angle of presentation would be increased to maintain the 50% detection rate.

Review of the previous literature on peripheral training led to the conclusion that the length and number of training sessions need not be extensive to produce improvement. It was decided that the initial training course would consist of five daily 1-hour sessions. This seemed to be sufficient time to determine if training would in fact produce improvements in peripheral detection. Modification of the training procedure for subsequent experiments would depend on the outcome of the first experiment.

CRITERION TESTS

During the literature review, no studies were discovered which specifically demonstrated that improvements in peripheral vision brought about by training successfully transfers to other peripheral vision functions or to other contexts. Since the major objective of this work was to determine if peripheral vision could be trained so as to be useful to driving, it was considered important to conduct criterion tests under simulated or actual driving conditions. An inherent drawback of driving simulators is that it is never certain that the relevant characteristics of driving are faithfully reproduced. There was no obvious reason why peripheral vision could not be tested during actual driving. An instrumented van with dual controls that had been used for several other on-the-road driving experiments was available for use. This vehicle was fitted with a small perimeter screen located around the driver's position and a projection system mounted over the driver's head for presentation of the test stimuli. (The test equipment is described in more detail later.)

Two types of tests were chosen for criterion testing: a vehicular silhouette recognition test and a motion sensitivity test. Initially, these tests were implemented on 8mm movie

film. Use of film was discarded subsequent to the first experiment due to several mechanical and procedural problems. The substitute procedures will be described in the section pertaining to Experiment III.

POPULATION OF SUBJECTS

Definition of the population from which training subjects would be drawn was a problem. The original intention was to use individuals with reduced peripheral sensitivity. It became apparent during the review of the literature that this would not be possible. No normative data, obtained under well-specified testing conditions, were available for establishing the criteria of deficient peripheral vision. Also, most losses of peripheral vision are absolute rather than relative. Injury or disease involving the eye or brain rarely, if ever, cause only a partial reduction in sensitivity.

Lack of data on which to base criteria for deficient peripheral vision and the inability to identify individuals with reduced sensitivity except by mass screening made it necessary to use a secondary criterion for subject selection. Since it is reasonably well established that general peripheral sensitivity decreases with age, it was eventually decided to use elderly individuals for training subjects. This decision was not reached, however, until Experiment I had already begun. For Experiment I the subjects ranged in age from 20 to 52 years. For Experiments II and III all subjects were 60 years of age or older with the exception of two subjects, one of whom was 52 and the other who was 57.

EXPERIMENT I

The purpose of this experiment was to determine if performance on a simple peripheral detection task could be improved through training and, if so, would the improvement transfer to performance on the criterion tests conducted during driving.

APPARATUS

The apparatus consisted of a large indoor projection perimeter for training and a small projection perimeter mounted at eye level around the driver's seat inside a 1971 Dodge van.

Training Apparatus

The training perimeter was located in a large windowless room 3.7 m x 4.6 m (12 ft. x 15 ft.). The perimeter screen was made of white cardboard and mounted on a curved frame forming a cylinder with a radius of 1.5 m (5 ft.). The screen was .76 m (2.5 ft.) high with the bottom edge located .82 m (2.7 ft.) from the floor. The walls surrounding the perimeter were draped with black curtains from floor to ceiling. The perimeter covered a total horizontal arc of 220°. A standard Dodge van seat and a steering wheel were located at the subject's position, the center of radius of the perimeter. Immediately above the subject's head was a platform which supported a ring of lights for background illumination of the perimeter screen and which also supported the projection apparatus, a Kodak Carousel 35mm slide projector. The projector was mounted so that the axis of projection could be rotated horizontally about a vertical axis extending through a point midway between the subject's eyes. The projector was inclined slightly so that the images on the screen were at the subject's eye level.

The central 20° of the perimeter was covered with gray cardboard and contained the apparatus for a secondary tracking

task. This task was designed to place attentional load on the subject comparable to steering a vehicle. It also provided a fixation target for the subject. A vertical white bar, 1.9 cm (7.5 in.) wide and 3.8 cm (1.5 in.) in height was located in the subject's median plane at eye level. Two red bars of the same dimension as the white bar were located above and below it. A waveform generator which produced three sine waves of different frequencies and amplitudes caused the bar to move in a random manner to either the right or the left. The subject, using the steering wheel in front of him, was required to cancel these displacements and maintain alignment of the white bar with the two red bars. The tracking apparatus had error limits which would cause a tone to sound if the bar drifted more than 1.5 line widths to either the left or the right.

The stimulus for the detection training task was a projected circular disc of light subtending 2° visual angle. The white projection area of the perimeter screen had an average background luminance of $.29 \text{ cd/m}^2$ (1 fL). There was a slight variation in the luminance of the perimeter screen in the vertical direction, ranging between $.26 \text{ cd/m}^2$ and $.32 \text{ cd/m}^2$, because the lights which illuminated the screen were located above the horizontal plane of the perimeter. The stimulus disc had a luminance of $.32 \text{ cd/m}^2$ and its contrast was therefore $.1.^2$

During training the disc was exposed for a period of 3 seconds. The onset of the stimulus was controlled by the experimenter. An automatic timing device extinguished the light at the end of 3 seconds. A schematic representation of the training apparatus is shown in Figure 1.

²All contrast values were computed using the conventional formula $C = (TL - BL)/BL$

where

C = contrast

TL = the target luminance

BL = the background luminance

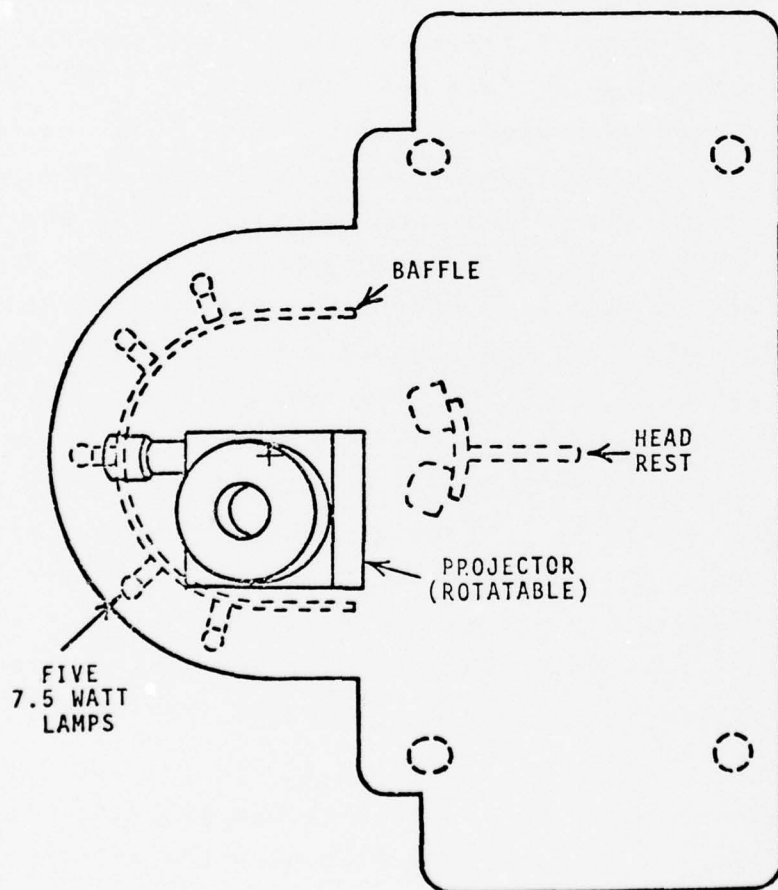
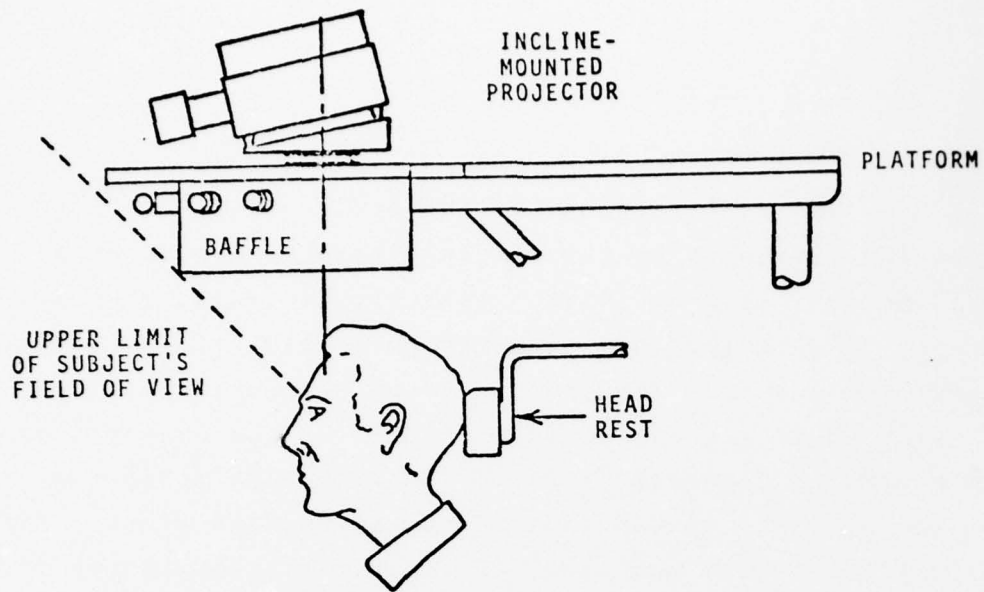

Figure 1. Training apparatus in side view (upper illustration) and plan view (lower illustration), shown in relation to the subject's position.

Testing Apparatus

Pre- and posttraining testing occurred in the Dodge van. The perimeter in the van consisted of a horizontal metal screen, 10.2 cm (4 in.) high with a radius of curvature of 50.8 cm (20 in.) centered on a point midway between the driver's eyes. The lower edge of the perimeter was slightly above the horizontal meridian of the driver's eyes. The perimeter extended from 100° on each side peripherally to within 20° of the subject's anterior median plane. The subject driver had unobstructed forward vision through the 40° open space between the two halves of the perimeter screen and unblocked vision to the left and right below the two screens. All surfaces visible to the subject were flat black except the projection surface which was white. The luminance of the two screens averaged .73 cd/m² which varied slightly with the lighting conditions (sun angle, cloud cover, and reflective properties of the road and surrounding terrain outside the van). The projection apparatus, an 8mm film projector, was located on a platform above the driver's head. The projector pivoted around a vertical axis which extended through the midpoint between the subject's eyes. The projection beam was diverted onto the screens by a periscope consisting of two first-surfaced mirrors. The entire projection system could be rotated to allow the experimenter to project an image on the screen at any location on the horizontal meridian in the driver's peripheral field. A hood prevented the driver from seeing where the periscope pointed. A schematic representation of the testing apparatus is shown in Figure 2.

To maintain adequate contrast of the projected targets within the van it was necessary to reduce the ambient light entering the van. All van windows, including the windshields, were covered with "Viewguard" transparent shade material, a three-layer mylar laminate. This material was used because

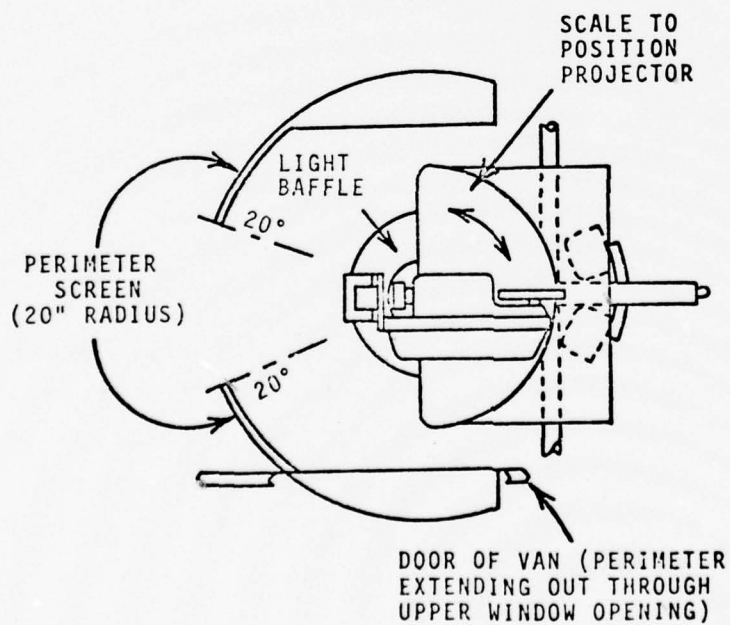
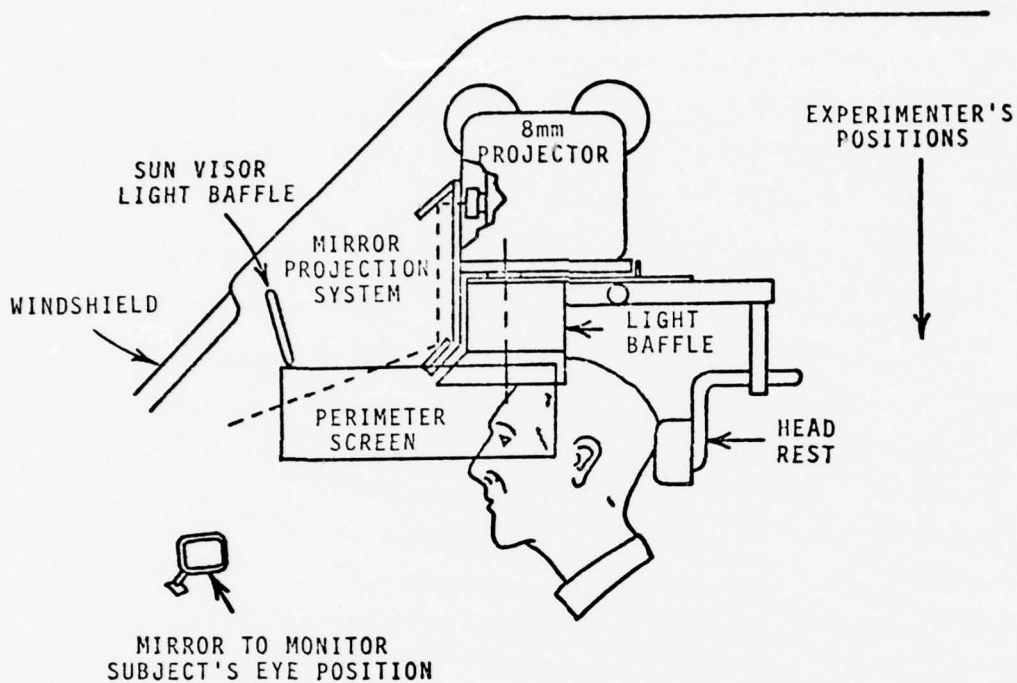

Figure 2. Testing apparatus in side view (upper illustration) and plan view (lower illustration), shown in relation to the subject's position.

it closely approximated the transmission characteristics of a neutral density filter and had a density of .778. Two layers of the material were placed over the passenger and driver door windows to further reduce glare sources. A black curtain positioned behind the subject's head blocked light from the rear of the van.

The subject's vertical, forward, and lateral head positioning was adjusted by use of a seat cushion and a headrest.

Three tests were conducted using the mobile perimeter; recognition of vehicular silhouettes, angular motion detection, and motion-in-depth detection. All three tests were on 8mm film. The four silhouettes used for the vehicle recognition test are shown in the upper part of Figure 3. When projected, each silhouette subtended approximately 5° horizontally at the driver's eye. During testing a silhouette was presented every 18 seconds for a duration of 167 msec.

Diamond forms subtending 2° on the diagonal were used for both the angular motion and depth tests. In the angular motion test the diamond appeared on the screen and moved horizontally either to the left or the right. For the motion-in-depth, the diamond would appear at its initial 2° size and either shrink or expand. For both types of motion tests the rate of motion with either 16, 24, 32, 40, or 48 minutes of arc per second. During testing, a stimulus diamond would appear every 18 seconds for a duration of 1 second.

The durations of presentation for both the silhouette recognition and motion stimuli were established by preliminary experimentation. The values were selected to produce approximately 50% correct detections during the initial test period. Thus there would be sufficient latitude in the tests to reflect changes in performance after training.

For both the silhouette and motion tests the background luminance of the perimeter screen was $.73 \text{ cd/m}^2$, and the

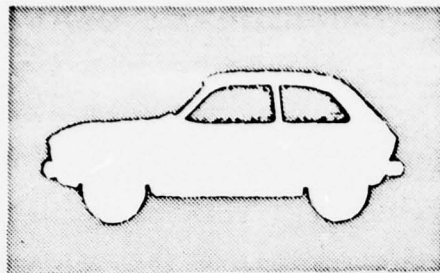

AUTOMOBILE

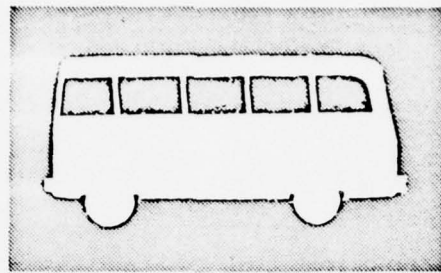

BUS

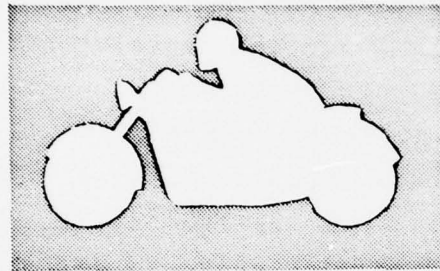

MOTORCYCLE

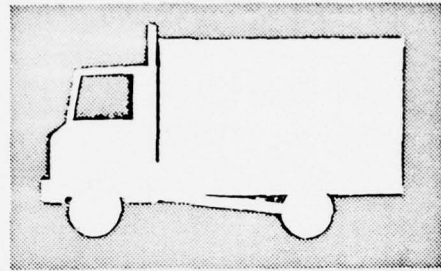

TRUCK

VAN TESTING STIMULI

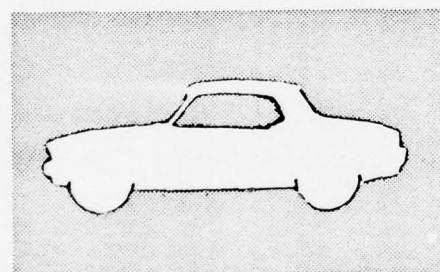

AUTOMOBILE

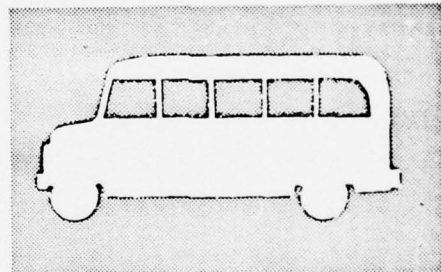

BUS

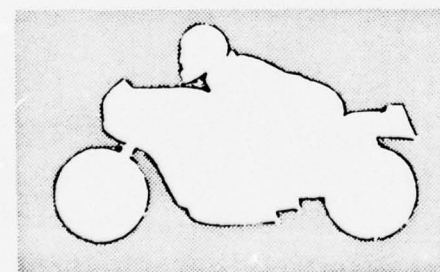

MOTORCYCLE

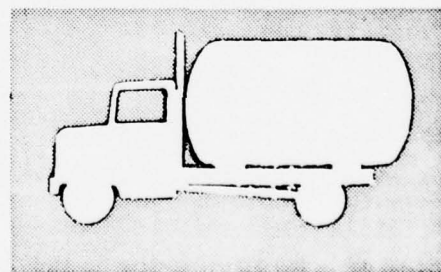

TRUCK

TRAINING PERIMETER STIMULI

Figure 3. Silhouette targets used for testing in Experiments I and III (top illustration) and training in Experiments II and III (bottom illustration).

luminance of the stimulus object was 10.1 cd/m^2 . The object contrast was therefore 12.8.

PROCEDURE

Testing and training of each subject occurred on 8 consecutive weekdays. On the first day the subject was shown the testing and training equipment and drove the van on a familiarization ride. On the second day each subject received the pretraining van test. The silhouette recognition test was performed first followed by the angular motion and motion-in-depth tests. The tasks of the subjects were to verbally report the side of presentation and the silhouette or type of stimulus movement presented on each trial. The next 5 days were devoted to training on the detection of the low contrast discs. On the eighth day posttests were given during driving. The tests and order of tests were the same as on the second day.

TESTING

During testing, the subject drove the van along a relatively straight and low traffic density section of a four-lane divided coastal highway between Goleta and Gaviota, California. This 23-mile one-way distance was covered at a speed of 45-50 mph allowing an uninterrupted test duration of about .5 hour. A rest break was allowed after each one-way excursion. Multiple round-trip excursions of this testing road were made during an entire testing period.

The stimulus series for the silhouette recognition test consisted of 12 groups of eight silhouettes. Each group consisted of one presentation of each silhouette on each side of the perimeter. Prior to the actual testing the subject was familiarized with the task and given a few practice trials with the silhouette forms. The angle of presentation of the silhouettes varied from 30° to 80° on each side.

The test was initially started with the first group of silhouettes projected at 30° . Depending on the subject's performance, the angle of presentation was either increased

or decreased for the next stimulus group. The order and side of presentation were determined by a random counterbalanced design. Regardless of the side of presentation of the silhouette, the depicted vehicle always faced forward. The experimenter, located in a seat above and behind the driver, rotated the projectors to the appropriate locations for the presentation. The film ran continuously during the test and the experimenter did not stop the film once it was started. When the subject detected a silhouette, he was required to identify it verbally and his response was recorded on a keyed score sheet by the experimenter.

In addition to the subject driver and experimenter, a third individual, the safety observer, rode in the van during testing. The safety observer had access to a dual set of steering and braking controls and had an unobstructed view forward, to the side and the rear of the van, either directly or through mirrors. He would continuously look around and monitor traffic approaching the van either through controlled access on-ramps or from the rear. The safety observer ensured that the driver fixated down the road during the presentation of the test stimuli by monitoring the subject's eyes via a mirror.

For each of the motion tests a stimulus series was comprised of six groups of 20 stimuli. Each stimulus in a group was a combination of one of the five rates of motion, one side of presentation, and one of two directions of motion. For the angular motion targets the direction of movement was either forward or backward relative to the driver. For the motion-in-depth stimuli, the direction of movement served to either enlarge or decrease the size of the image. The order of presentation of stimuli within a group was determined by a randomized counterbalance design.

The protocol for presentation of the stimuli to each subject was similar to that used for the silhouette test. The subject was given some familiarization with the target

and a few practice trials. During testing the initial group of stimuli was presented at 45°. The projector, which ran continuously, was oriented to the proper location and side between trials by the experimenter. When the subject detected a diamond, he verbally reported its side and direction of movement. The experimenter recorded the response on a keyed data sheet. Depending upon the subject's performance at 45°, the next group of stimuli was presented at either a greater or lesser peripheral angle. The angle of presentation was varied in an attempt to maintain a 50% to 60% correct detection level.

Essentially both the silhouette and motion tests were conducted in a manner designed to yield measures of field extent. By attempting to maintain performance at a 50% to 60% level, the maximum peripheral angle at which this could be maintained would be the index of performance.

Posttraining testing in the van was identical to pre-training testing.

TRAINING

Training was conducted for 1 hour a day on 5 consecutive weekdays for each subject. During each training session, the subject was seated with his head position adjusted by a headrest to correctly center his eyes with respect to the perimeter screen. The secondary tracking task was started and the subject was given a few moments to become accustomed to it and stabilize his performance.

Once the subject had the tracking test in hand, the actual training began. The low contrast disc was presented on a random basis on the left or right screen starting at 20°. The subject's task was to detect the disc and call out the side of presentation. The experimenter recorded on a score sheet, keyed only for side of presentation, the angle of presentation and whether or not the stimulus disc was detected. Performance on the left and right sides was scored independently. If a subject correctly detected the

stimulus, the angle of presentation and a mark indicating a correct response were entered. If the subject made two successive correct detections at a particular peripheral angle on a particular side, the next stimulus presentation on that side would be 5° farther into the periphery. Any time a subject failed to make a correct detection, the next stimulus on that side would be presented 5° more centrally.

When the subject failed to detect the stimulus within a 3 second duration, the experimenter would point out that he had missed the stimulus and turn it on and off for about 3 seconds at the same location. The intent was to allow the subject to attend to the stimulus while he knew its location. After this feedback the training continued according to the schedule.

As mentioned earlier, the tracking test had error boundaries. If the subject failed to maintain tracking within the error limit a tone was sounded. If the tone occurred during a stimulus presentation, the experimenter disregarded the subject's response and repeated the stimulus later in the series. The tracking task was designed so that failure to fixate the moving bar would be likely to result in a failure to maintain tracking performance. As an additional check on fixation, the experimenter would occasionally glance around the side of the projector platform and observe the subject's eyes. The subject was not aware of this monitoring by the experimenter, but from his position the experimenter could determine whether the subject was maintaining fixation or searching for the peripheral target. In general, the subjects were cooperative and rarely moved their eyes to either side. On the occasions when they did, they usually notified the experimenter.

SUBJECTS

Five individuals, three men and two women, ages 20, 32, 39, 50, and 52 served as subjects. All had current California driver's licenses. Three of the five subjects, who were

required to wear glasses for driving, wore them for all testing and training.

RESULTS

The data for detection training during Experiment I are shown in Table 1. The data are expressed as the peripheral angle for the right and left eyes at which the target could be detected 50% of the time. These data were obtained by calculating the percent correct detections for each angle used during a particular training day and interpolating to the angle which would represent 50% detection. The table shows only the results obtained on the first and last days of training. The differences between the scores obtained on the first and fifth days of training are shown in the third column of the table.

Notice that the results are mixed. Generally, improvement can be seen for three of the five subjects, but only Subject 3 showed substantial changes. Unfortunately, this difference is likely to be artificial. This particular subject wore heavy framed glasses. The frames of the glasses tended to occlude approximately 15° of his peripheral field on the left and right sides from 50° outward. During training on the first 2 days, it was impossible to jump this 15° gap. Because of this impasse, the subject was told to remove his glasses since it was evident that he would not progress any further by wearing them. After removal of his glasses, he showed steady progress for the remaining 3 days. It seems likely that the glasses were interfering with this subject's initial performance also, since during the first day he successfully detected the target at about 50° , which was near the edge of the frames of his glasses. Discounting the results obtained from this subject for the reason stated, improvement on the part of the other subjects either did not occur or was minimal.

Results from the van test were equally disappointing. No evidence of improvement was apparent. The data were extremely

TABLE 1
 TRAINING DATA SUMMARY
 FOR TRAINING TECHNIQUE #1

DETECTION PERFORMANCE
 (mean angular position of stimulus)

Subject	Eye	Day 1	Day 5	Diff.
1	Right	62.4°	67.2°	4.8°
	Left	62.5°	68.0°	5.5°
2	Right	71.8°	70.7°	- 1.1°
	Left*	57.2°	47.6°	- 9.6°
3	Right	50.9°	72.1°	21.2°
	Left	54.7°	65.7°	11.0°
4	Right	71.1°	77.3°	6.2°
	Left	70.4°	72.8°	2.4°
5	Right	62.9°	66.6°	3.7°
	Left	62.8°	61.6°	- 1.2°

*Detached retina in left eye, surgically reattached.

variable and, had improvement occurred, it is doubtful that they would have revealed any transfer effects.

No data are shown for the van test. The original intention, when the silhouette data were collected in the van, was to specify field size by finding the peripheral angle that corresponded to 50% correct recognition. A general decline of performance with peripheral eccentricity would normally be expected. Unfortunately, there was a great deal of variability and, in several instances, performance on the silhouette detection task actually increased with eccentricity. Generally the results appeared highly unsystematic. The reasons for this variability will be addressed in the Discussion section.

The data from the motion test were also highly variable. Recognition of the direction of motion for both the angular movement and movement-in-depth tests did not change appreciably with rate of movement. That is, detection performance for the lower image speed, 8 minutes of arc per second, was equal to, or in some cases exceeded, the detection performance for the highest speed, 48 minutes of arc per second. It became apparent during the pretraining testing that to obtain detection scores between 50% and 100% the motion stimuli should be presented at 75° peripherally. This was done on the pre- and posttest for four out of the five subjects. One subject could not detect the diamonds at all, let alone recognize the direction of motion at 75°. The motion data for the four subjects who were consistently tested at 75° were tested for significance using analysis of variance (ANOVA). No significant differences between pre- and posttesting were found.

Because of the high variability of the data, the results of Experiment I were considered inconclusive. Several methodological lessons were learned from this experience, however, and these are discussed on the following pages.

DISCUSSION

The principal conclusion that can be drawn from Experiment I is that there were serious deficiencies in the training and testing methodologies.

During training, all subjects remarked that it was difficult to perform the tracking and peripheral detection tasks simultaneously. They found the training sessions to be fatiguing. Neither task was considered difficult by itself, but all the subjects thought that the combination was too demanding.

A second comment expressed in one way or another by all the subjects was that the training sessions, lasting 1 hour, were extremely boring. There was little dialogue between the subject and the experimenter during training other than notification that a stimulus had been missed. Also, it was evident to most subjects that they were not doing any better on the detection task from day to day. Consequently, it is very likely that the motivation of the subjects was low due to these adverse and monotonous conditions of the training task.

The type of peripheral function trained, light detection, may also have contributed to the failure of training to produce improved performance. Detection of light is the most fundamental function of the visual system. As such, it may be almost entirely dependent upon basic physiological factors and not be improvable by training. All other peripheral training experiments reported in the literature involved the training of more complex visual functions, such as acuity or motion detection.

It is doubtful that attentional factors importantly affected the outcome of this experiment since, through experience, each subject was aware of the approximate loci, to the left and right, where a stimulus would appear and also the approximate time that a stimulus would appear.

Deficiencies in the van testing methodology were also identified. The primary problem with the van tests was the inability to control the time of onset of a stimulus. Since all stimuli were on film which ran continuously, a stimulus could occur at any time regardless of what the driver was doing.

Driving was the subject's primary task and required the usual functions of tracking the highway, watching for other vehicles, monitoring the speedometer, and checking the rear-view mirrors. Consequently, a subject was often devoting his attention to some driving task when a stimulus occurred. Originally it was thought that this was acceptable since the goal of the testing was to determine peripheral vision functions during normal driving activity, and the generally non-alerted state of the driver to peripheral stimuli would be characteristic of this condition. It was expected that the subjects would become somewhat accustomed to estimating the interval between stimuli and would have at least some expectation of when stimuli would occur. The relatively long inter-stimulus interval of 18 seconds made this difficult. Additionally, when the subject missed one stimulus the task of anticipating the approximate time of occurrence of the following stimulus was even more difficult. When the subject was simply fixating down the road with minimal demands on his attention from driving, a stimulus was rarely missed. Overall, however, the number of stimuli missed played havoc with the data.

A second problem with the van tests was that the amount of data collected was somewhat limited. For the silhouette test each subject saw 96 stimuli. This was distributed across the four types of silhouettes, the two sides, and the three locations of presentation. This means there were only four repetitions of each unique stimulus combination. Collapsing across the different types of silhouettes still yielded only 16 data points for a given side and peripheral

angle. With this small number of data points, missing two or three stimuli at a given location has a large impact on the final score obtained.

A similar problem occurred for the movement test. Each of the two types of movement test consisted of a presentation of 120 stimuli. During testing the three peripheral angles were tested on the right and left sides. The actual angle tested varied with the subject. For these tests there were only two repetitions for each unique stimulus condition. Again, missing stimuli had a marked effect on the performance scores.

It was known beforehand, of course, that the number of repetitions for each unique stimulus condition would be low. The decision to use only 96 stimuli for the silhouette test and 120 stimuli for each of the motion tests was influenced by two factors. The first factor was the total testing time required. At 18 seconds per stimulus the total testing time was approximately 1 hour and 40 minutes. Since not all stimuli could be placed on a single reel of film, it was necessary to use two reels for each of the three tests. The van was stopped to change reels, which also gave the subject a break. An entire testing period, then, lasted a little over 2 hours.

Even with the planned breaks to minimize subject fatigue, driving and performing the peripheral tests over a 2-hour period was a fairly demanding task for the subjects. It was initially believed that an interstimulus interval shorter than 18 seconds would probably be too distracting from the primary task of driving safely on a public highway. Also, the experimenter required most of this time to record a subject's response, check the scoring key for the next side and angle of presentation, and move the projector to the proper position. Increasing the number of stimuli would have lengthened the total testing time. As initially anticipated, 2 hours was the maximum time we could expect a subject to perform these tests. Possibly two testing sessions rather than one

could have been used. This would have added 2 extra days, 1 for pretesting and 1 for posttesting, to the total length of the time required of each subject. This initially appeared to be impractical if a large number of subjects was to be tested during the overall course of this study.

In spite of the small amount of data collected for each test, two assumptions led to the belief that this amount of data would be adequate to reflect pre- and posttraining differences in performance. First, it was assumed that the subject's detection performance would be relatively consistent. That is, it was assumed that the subject would have no difficulty detecting the onset of either a silhouette or one of the motion test diamonds, and the performance differences would be reflected in the ability to correctly recognize the silhouette or the direction of movement. The second assumption was that the relatively large changes in peripheral angle at which tests would occur, 20°, would result in dramatic changes in performance. It turned out, of course, that neither of these two assumptions was valid. Detection of the stimuli was a problem for the reasons stated earlier and performance did not change markedly with changes in peripheral angle. Also, for the motion tests there were no apparent differences in performance as a function of rate of motion. It is likely that the large variability in performance obscured the expected differences for the different angles of presentation and movement rates.

CONCLUSIONS

Several methodological conclusions were drawn from these results:

1. Performance of a central task during peripheral training was too demanding on the subjects. Future training courses should be limited to performance of the peripheral task only.
2. If the subject's interest and motivation were to be maintained during training, the task would have to be made more interesting and a greater

amount of interaction between the subject and the experimenter would be desirable.

3. Training on a simple sensory task may be non-productive. Subsequent peripheral vision training courses should use more complex tasks such as acuity and form recognition or motion perception for the training tasks themselves.
4. Progress during training should be assessed not only by performance on the training task, but also by one or more additional criterion tests of peripheral vision functions other than those trained.
5. The experimenter should have complete control of the van testing situation. That is, the experimenter should be able to select the stimulus target, its location of presentation, and its time of presentation.
6. The number of testing sessions should be extended to collect enough data to determine if statistically reliable improvements in peripheral vision occur due to training.
7. Use of subjects who are not required to wear glasses would be preferable to eliminate the physical impediments to the detection of peripheral targets during training and testing.

EXPERIMENT II

The failure of the first experiment to show that training could improve peripheral vision was attributed to methodological deficiencies. In Experiment II the methods of training were changed substantially. It was decided to train form recognition using flash presentations of vehicular silhouettes similar to those used for the van test in Experiment I.

The training methodology was less structured with an emphasis upon increased subject/instructor interaction. That is, the instructor engaged in a great deal of dialogue with the subject about his performance and the nature of the stimuli, and he attempted to motivate and encourage the subject. Performance feedback was again provided, but in a less impersonal manner. Further, the experimenter encouraged the subject to think about peripheral vision and consciously attempt to practice using peripheral vision during his normal everyday activities.

The length of the training was extended from 5 days to a total of 10 days. The training sessions were again 1 hour in length, but at least two breaks were taken during each session. No pretraining or posttraining van tests were used during this experiment. The primary objective was to attempt to demonstrate that peripheral vision could be significantly improved, and if the findings were positive, a subsequent experiment would be conducted to determine whether the training successfully transferred to the driving situation.

Despite the unstructured nature of the subject/instructor interactions, objective measures of performance on the silhouette recognition tasks were taken throughout the course of training. A kinetic perimetry test involving the recognition of smaller versions of the training silhouettes was administered at the beginning and end of each day of training. Also,

the Mark I Integrated Vision Tester (Henderson, et al., 1971) was used for pre- and posttesting of the subjects. These additional tests were used to determine if any improvements realized through training would generalize to other uses of peripheral vision. The Mark I Integrated Vision Tester contains several tests of peripheral vision. Since this device had been used in previous research relating vision to accidents (Henderson & Burg, 1974), it was considered worthwhile to determine if improvements following peripheral vision training would transfer to the type of tests incorporated in this device. The nature of these additional tests is described more fully in the Procedure section and in Appendix A.

APPARATUS

Training

The apparatus used for training was the same as that used for the first experiment except for changes in the projection equipment. Rather than one, two Kodak Carousel 35mm slide projectors were mounted on the platform above the subject's head in a fixed position. By the addition of the second projector the projection system could be used to project images on both the right and left halves of the perimeter screen, either simultaneously or independently. The projectors were directed at two first-surface mirrors which, in turn, reflected the projector beams onto the perimeter screen. The projectors were positioned so that the images formed on the screen were at the subject's eye level. The two mirrors could be rotated simultaneously about vertical axes and were situated so that the axis of rotation of each mirror was as close as possible to being equidistant from all points of projection on the appropriate half of the perimeter screen. This arrangement allowed lateral displacement of the projected image on the screen with no detectable change in angular size or focus. The projection of stimuli was controlled by a silent switch and timer that limited the duration of presentation. Either

or both projectors could be turned on for an indefinite period by means of a switch bypassing the timer circuit. The projection system is shown in Figure 4.

The training stimuli used in this experiment were four vehicular silhouettes: an automobile, a bus, a motorcycle, and a truck shown in the bottom half of Figure 3. Two sizes of the silhouettes were used for the indoor perimeter training and testing. The large sized silhouettes had a horizontal extent of 5° ; the smaller an extent of 2.4° . When projected, the luminance of each silhouette was 5.46 cd/m^2 , and the contrast with the $.29 \text{ cd/m}^2$ screen luminance was 17.7. The silhouettes were always seen by the subject with the front of the vehicle facing forward on the perimeter screen.

During training the silhouettes were projected for a duration of 250 ms. The timing unit controlled the flow of current to the projector bulbs. Since the projector bulbs were incandescent, there was an appreciable rise and fall time in luminance when the current was turned on and off. To accurately characterize the stimulus exposed to the subject, the curve of luminance by time was determined using a phototransistor and a storage oscilloscope. Figure 5 is a reproduction of the luminance curve which was identical for both projectors.

Testing

Prior to and after the training program, or an equivalent time interval, all the experimental and control subjects were to be tested on the Mark I Integrated Vision Tester built by Systems Development Corporation, Santa Monica, California, under the sponsorship of the National Highway Traffic Safety Administration. A description of the apparatus can be found in Henderson, et al. (1971) and Henderson and Burg (1974).

Eight of the tests incorporated in the Mark I Integrated Vision Tester were used in the present experiment: static acuity under normal illumination (SA); central angular movement

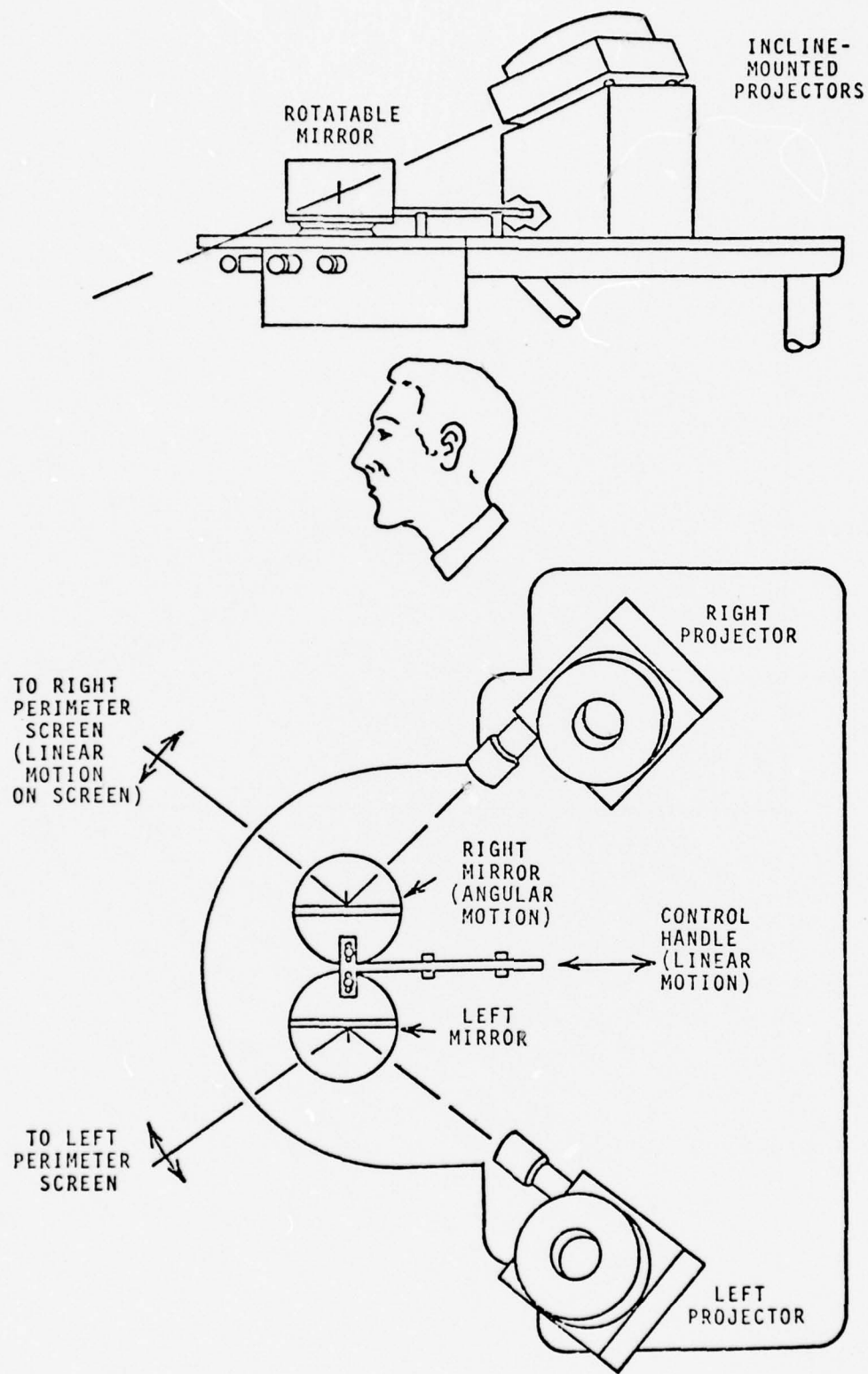

Figure 4. Dual-projector training apparatus in side view (upper illustration) and plan view (lower illustration), shown in relation to the subject's position.

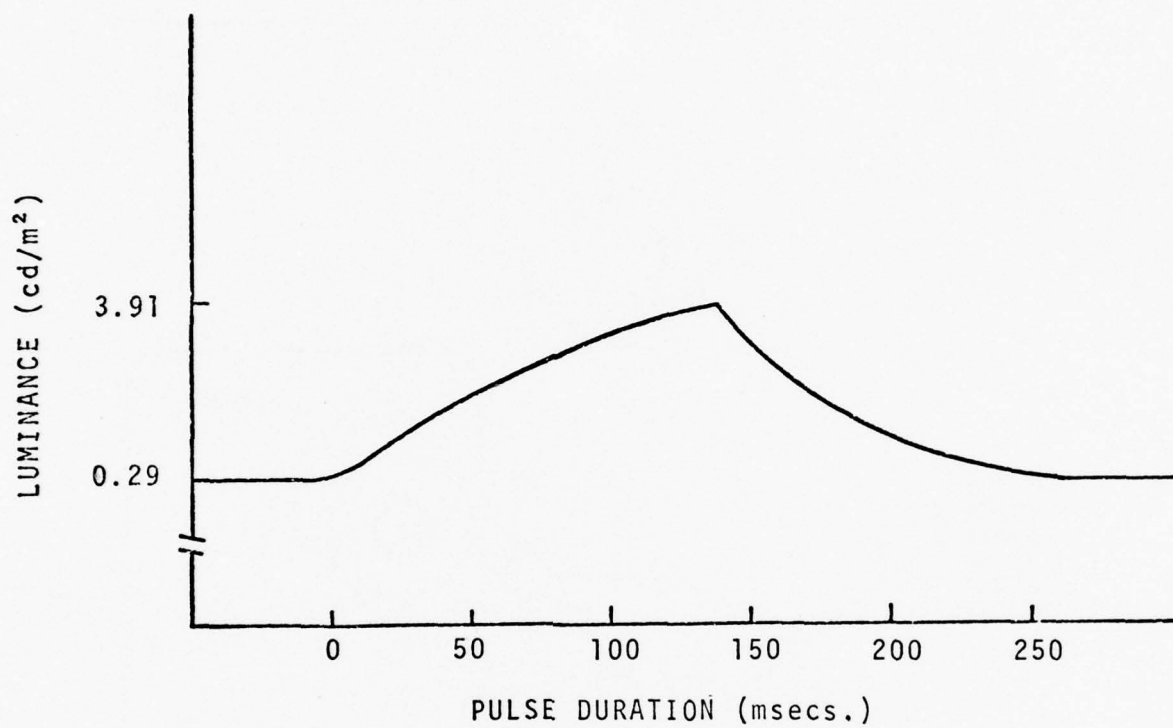

Figure 5. Luminance curve for training projectors.

(CAM); central movement in depth (CMD); peripheral angular movement (PAM); peripheral movement in depth (PMD); field of vision (FOV); detection, acquisition, and interpretation 90° (DAI-90); and detection, acquisition, and interpretation 35° (DAI-35). A complete description of these tests and the testing procedure extracted verbatim from Henderson and Burg (1974) is given in Appendix A.

The Mark I testing, however, was not run to completion. Due to circumstances described in the Procedure section, only four of the nine control subjects were tested on the Mark I. The other five control subjects were given the kinetic perimetry test and a peripheral form recognition test based on the training procedure. These tests used the training projection equipment and the 2.4° and 5° vehicular silhouettes.

PROCEDURE

A summary of the testing and training schedule for Experiment II is contained in Table 2. All experimental subjects were familiarized with the testing and training apparatus and tested on the Mark I on the first day, received 10 days of training and kinetic perimetry testing, and were retested with the Mark I on the 12th day. Each experimental subject was also asked to return in 60 days for retention testing.

The control subjects participated for only 2 days of testing separated by a 10-day interval.

Training

Each experimental subject received approximately 35 minutes of training during each of the 10 daily sessions. A 5-minute break was taken halfway through the training session. The subjects were encouraged to ask for a break at any time they felt fatigued.

Two types of training procedure were used on alternate days. On the first day, and every other day thereafter, the subject was trained to recognize vehicular silhouettes presented

TABLE 2
SUMMARY OF EXPERIMENT II TESTING AND TRAINING SCHEDULE

EXPERIMENTAL GROUP (N = 9)	CONTROL GROUP A (N = 4)	CONTROL GROUP B (N = 5)
PRETESTING	INITIAL TESTING	INITIAL TESTING
A. Mark I vision testing B. Familiarization with testing and training apparatus	Mark I vision testing	A. Kinetic perimetry test B. Single- and dual-silhouette recognition test C. Kinetic perimetry test
TRAINING		
Days 1, 3, 5, 7, 9 A. Kinetic perimetry test B. Single-silhouette recognition training* C. Kinetic perimetry test	10-day interval	10-day interval
Days 2, 4, 6, 8, 10 A. Kinetic perimetry test B. Dual-silhouette recognition training* C. Kinetic perimetry test		
POSTTESTING	FINAL TESTING	FINAL TESTING
Mark I vision testing	Mark I vision testing	A. Kinetic perimetry test B. Single- and dual-silhouette recognition test C. Kinetic perimetry test
60-day interval		
RETENTION TESTING		
Day 1 A. Kinetic perimetry test B. Single-silhouette recognition training C. Kinetic perimetry test		
Day 2 A. Kinetic perimetry test B. Dual-silhouette recognition training C. Kinetic perimetry test		

*The 5° silhouettes were used on all training days except 7 and 8 when the 2.4° silhouettes were used.

singly on either the right or the left side. On the second day, and every other day thereafter, the subject was trained to recognize two silhouettes presented simultaneously on the left and right sides of the perimeter screen. These two training procedures are referred to as "single-silhouette training" and "dual-silhouette training," respectively. For both procedures the duration of stimulus presentation was 250 ms. The large 5° silhouettes were used for both training procedures with the exception that on the fourth day of training of each procedure, the small, 2.4° silhouettes were used. The small silhouettes were used to provide some novelty in the training course and also to determine if 2 days of training using smaller or more difficult silhouettes for the training course would produce a noticeable improvement in performance on the succeeding days when the large silhouettes were used again.

On the first day of each type of training, the 5° silhouettes were initially presented at 20° to the left and/or the right. Prior to the presentation the experimenter would say, "Ready," to signal the subject to fixate the white bar in the center of the perimeter screen (this bar, now stationary, was part of the central tracking task in the first experiment). The experimenter would press a button which, after an interval of 1 to 1.5 seconds, would turn the projector(s) on. The subject would name the silhouette(s) seen, and the experimenter would record the response. The experimenter would then announce whether the subject's response was right or wrong. He would usually couch the feedback in some phrase or sentence of congratulations or commiseration, depending upon the correctness of the response. Regardless of whether the subject's response was correct or incorrect, the silhouette(s) was shown again continuously for a period of 2 to 4 seconds, and the subject was encouraged to "notice with his peripheral vision" the nature of the silhouette. The experimenter then ended the presentation and interchanged the slides in both projectors

several times, using an automatic control, and finally stopped with the slide or slides positioned for the next presentation. A keyed score sheet was used to determine the order of presentation of the silhouettes or the pairs of silhouettes and for recording the subject's responses.

During the single-silhouette training procedure the slides were interchanged in both projectors between presentations. If the experimenter had interchanged slides in only one projector, the subject would have heard it and anticipated the side of the next presentation. Also, since it was possible for the same silhouette or pair of silhouettes to be shown consecutively, the interchanging of slides in each projector prevented the subject from predicting a reoccurrence of the same silhouette(s).

For the single-silhouette training procedure, the side of presentation and the silhouettes were ordered randomly with the constraint that over a block of 16 presentations each silhouette occurred on each side equally often. The subject's performance on the left and right sides was scored independently. If the subject responded correctly on two consecutive presentations on a given side, the angle of presentation was increased by 5° . Any time the subject gave a single incorrect response, the angle of presentation was reduced by 5° .

For the dual-silhouette training procedure, any one of the four vehicular silhouettes could occur with any other, including itself. Combining all four silhouettes on the left with all four silhouettes on the right resulted in 16 unique silhouette pairs. The order of presentation of the pairs was randomized with the constraint that each unique pair should be presented at least once before any pair was repeated.

Each silhouette of the pair was presented at equal angles on the left and right sides. If the subjects correctly identified both silhouettes on three consecutive trials, their angle

of presentation was increased by 5°. If the subject failed to identify both silhouettes of the pair on three consecutive trials, the angle of presentation was decreased by 5°. Also, if the subject failed to identify one silhouette of the pair, regardless of side, on six consecutive trials, the angle of presentation was reduced by 5°.

During the course of the training sessions the experimenter would carry on an almost continuous dialogue with the subjects regarding peripheral vision and the characteristics of the vehicular silhouettes used as training stimuli. The subjects took to this very readily and would generally give introspective reports about what cues they thought they were using to discriminate among the silhouettes. The experimenter also gave a great deal of encouragement to the subjects to do their best and would congratulate them when the criterion was reached for displacing the stimuli 5° more peripherally. The subjects soon developed an attitude of treating the training sessions as a challenging game with a serious purpose. At the end of the training session the experimenter would review their performance with them and point out how it compared with previous days of training.

Mark I Vision Testing

All of the experimental subjects and four control subjects were administered the Mark I Integrated Vision Tester tests on two occasions. The experimental subjects were tested on the day before training began and on the day after training ended. The control subjects were tested on two separate occasions separated by an interval of 10 days, the length of the training course.

Initially it was planned to test all nine control subjects with the Mark I Integrated Vision Tester. However, by the time the control subjects were tested, the nine experimental subjects had completed the testing and training procedures. Analysis of their test data revealed that there were no

significant changes in the Mark I Vision test scores following completion of the peripheral vision training program. Because of this result there was no point in continuing to test control subjects with the Mark I Integrated Vision Tester since nothing of interest would be revealed. (By this time four control subjects had received the Mark I Integrated Vision Tester tests on the two separate occasions.) Rather than continue, the remaining five control subjects were tested twice at 10-day intervals with the same kinetic perimetry test as administered to the experimental subjects and were also tested twice for their ability to recognize single and dual silhouettes.

Kinetic Perimetry Testing - Experimental Subjects

Prior to and at the end of each training session each experimental subject was given a kinetic perimetry test. The small, 2.4° vehicular silhouettes were used for this test. The silhouettes were presented singly on one side of the perimeter. During the procedure the subject saw each of the four vehicular silhouettes twice on both the right and left sides. Each silhouette was exposed continuously during the test. The silhouette was projected starting at 90° on only one side and moved toward the front of the perimeter screen at approximately 5° /second. Movement of the silhouette was under the experimenter's control and was continued until the silhouette was recognized.

The series of 16 silhouettes, 8 to each side, was given in the following manner. A side for the initial presentation was chosen randomly. Either 3 or 5 silhouettes were shown sequentially to this side. If 3 silhouettes were shown, they were all unique. If 5 were shown, 1 selected at random was presented twice. Then 8 silhouettes, 2 of each vehicle, were presented on the opposite half of the perimeter screen. Once this was completed, the procedure resumed on the side on which testing began. If the subject had originally seen only 3 silhouettes on the initial side, 5 more were shown to complete

the series of 8 presentations. Similarly, if the subject had been shown 5 silhouettes on the initial side, only 3 more were shown to complete the series.

This procedure was chosen over one in which the silhouettes were randomly presented right and left because it minimized experimenter time, effort, and errors. A preliminary subject was tested using both a completely random procedure and the procedure just outlined with no differences in the results.

The experimenter recorded the angle of recognition for each silhouette presented on each side of the perimeter screen.

Kinetic Perimetry and Recognition Testing - Control Subjects

Five of the control subjects were also administered the kinetic perimetry test and tests of their ability to recognize single and dual presentations of the large 5° silhouettes used for training of the experimental subjects. These latter tests were administered under the same conditions and using the same procedures employed during training.

It had become apparent during the silhouette recognition training and kinetic perimetry testing of the experimental subjects that there was a large improvement in performance during the first session. During training, performance improved rapidly during the first 20 minutes or so. Also, there was a marked difference in the kinetic perimetry scores between the initial and final tests given on the first day of training. This rapid improvement may have resulted from the subject becoming familiar with the silhouette targets during training.

It was decided, therefore, that the control subjects should also be given familiarization trials with the large silhouettes to allow an unbiased determination of their performance on the kinetic perimetry test and on the silhouette recognition tests. The control subjects received an abbreviated version

of the training course during the initial and final days of testing. This provided a stronger basis for comparing the performance of the experimental and control subjects on both the kinetic perimetry test and large-silhouette recognition tests.

The five control subjects were first shown the stimuli they were expected to recognize, and then the initial kinetic perimetry test was administered. Over a period of the next hour, the control subjects were trained and their performance scores recorded for the single- and dual-silhouette presentations. The maximum angle at which they could recognize the silhouettes was determined by the same criterion used for the experimental subjects. At the end of this test/training period, the kinetic perimetry test was repeated.

Retention Testing

On the last day of the training course when each experimental subject was retested with the Mark I Integrated Vision Tester, he was also asked if he would be willing to return in approximately 2 months for a test to determine how much of the improvement in peripheral vision was retained. All subjects expressed willingness to do this. Two days were devoted to retention testing. On the first day the kinetic perimetry test and a test version of the dual-silhouette recognition task were administered. On the second day the subjects received testing on the single-silhouette recognition task. The kinetic perimetry test was administered at the beginning of the first retention test session. The procedure was identical to that used during the training course.

The procedure for determining at what angle the single- and dual-silhouette presentations could be recognized was similar to that used during training. For the retention testing, the presentations began at a peripheral angle 20° less than the subject's final performance level at the end of the training course. The mode of presentation was identical

to that used during training, and the subject was told whether he correctly or incorrectly identified a silhouette or a silhouette pair, but stimuli were not reshown after each trial.

The presentation continued as in the training course with the angle of presentation being advanced according to the same criterion. Each of the silhouette recognition tests required approximately 30 minutes.

SUBJECTS

Eighteen individuals, ages 52 to 76, participated as subjects. All held current California driving licenses.

The population from which the experimental and control subjects were drawn differed slightly. All experimental subjects were residents at a private retirement apartment complex. An insufficient number of volunteers from this population were available for the control groups. Therefore, the control subjects were solicited through advertisements in the local newspaper. The age, sex, and whether or not glasses were worn is shown for each subject in Table 3.

RESULTS

Training Task - Experimental Subjects

Figure 6 is a plot of the mean performance data obtained from the nine experimental subjects on the single- and dual-silhouette recognition training tasks. Since no significant differences between side of presentation were found, the data obtained for the left and right sides on the single-silhouette recognition task have been averaged. The data from the training course are in terms of the most extreme peripheral angle at which a vehicular silhouette or pair of silhouettes could be correctly recognized. Recall that during training the subject was required to recognize a single silhouette or pairs of silhouettes, either two or three times in a row, before the presentation was advanced 5° more

TABLE 3
 CHARACTERISTICS OF INDIVIDUALS WHO
 PARTICIPATED IN EXPERIMENT II

EXPERIMENTAL SUBJECTS

Subject Number	Age	Sex	Glasses
1	52	F	No
2	63	F	Yes
3	64	M	No
4	67	M	Yes
5	66	F	Yes
6	64	M	No
7	70	M	Yes
8	62	M	Yes
9	76	F	Yes
	Mean Age: 64.8		

CONTROL SUBJECTS

Subject Number	Age	Sex	Glasses
1	61	F	Yes
2	73	M	Yes
3	60	F	Yes
4	64	M	No
5	66	F	No
6	63	M	Yes
7	61	M	Yes
8	66	F	Yes
9	67	F	Yes
	Mean Age: 64.5		

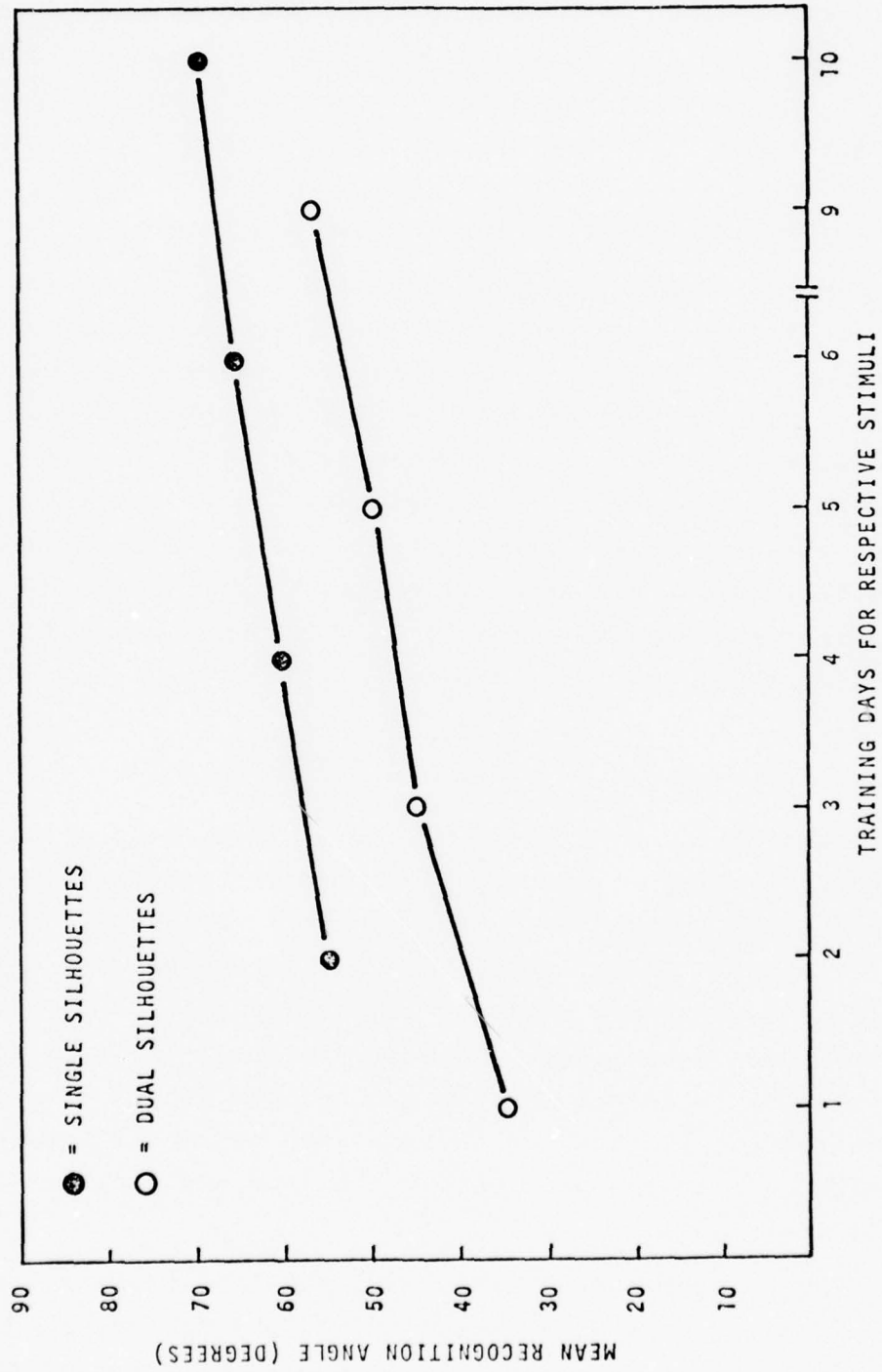

Figure 6. Mean training performance with large (5.0°) single and dual silhouettes for all experimental subjects (N = 9).

peripherally. For example, if a subject could correctly recognize a single silhouette twice at 55° , or a pair of silhouettes three times in a row at 55° , the next presentation would be at 60° . The data presented is the maximum angle which had been exceeded according to these criteria and not the angle at which the subject was currently being trained. Thus, if a subject was working at 60° at the end of a training session but had not successfully reached criterion, his angular score for the day would be 55° .

For the single- and dual-silhouette recognition tasks only the 4 days where the large 5° silhouettes were used are shown. The mean angular difference between the first and last days of performance was 14.1° for the single-silhouette task. A one-way ANOVA ($df = 3, 24$; $F = 27.9$; $P < .01$) confirmed that the improvement in peripheral recognition performance was significant. For the dual-silhouette recognition task, the mean difference between the first and last days' performance was 12.2° . An ANOVA confirmed that this difference was also significant ($df = 3, 24$; $F = 23.3$; $P < .05$).

Training Task Retention - Experimental Subjects

Seven of the nine experimental subjects were given a retention test approximately 60 days after completion of the training course. The other two subjects were not available for retesting. The mean training and retention data on the single-silhouette and dual-silhouette recognition tasks, plus the retention scores, are shown in Figure 7. No statistical analysis was performed, but it can be seen that 2 months after the completion of training the subjects could still recognize the silhouettes at approximately the same angle as at the end of training.

Figures 8 through 16 show individual silhouette recognition data for the nine experimental subjects and the retention scores for the seven individuals who were retested.

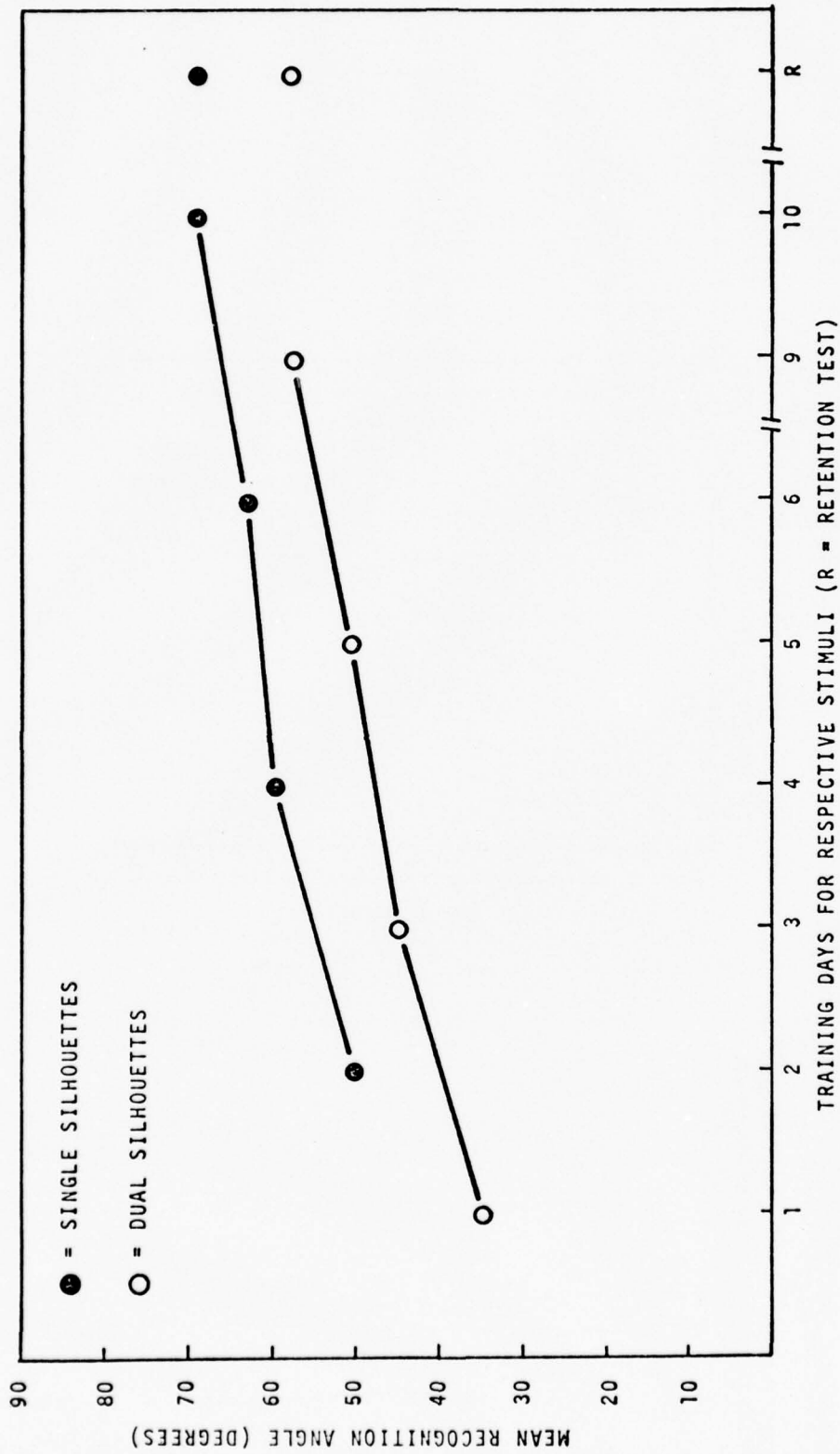

Figure 7. Mean training performance with large (5.0°) single and dual silhouettes for the experimental subjects tested for retention (N = 7).

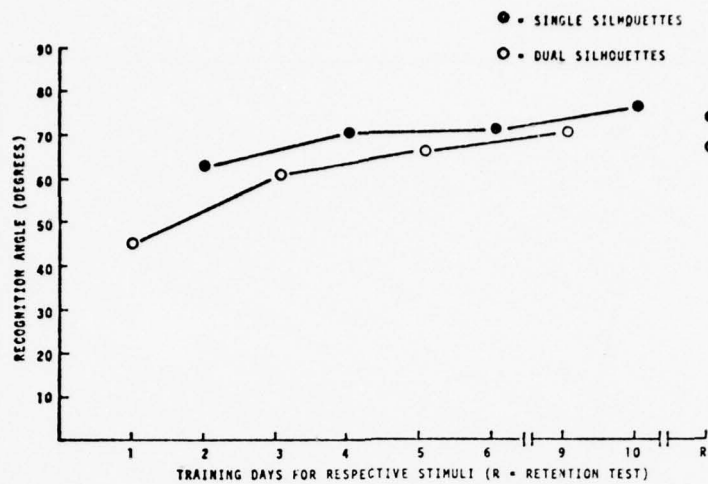

Figure 8. Subject 1.

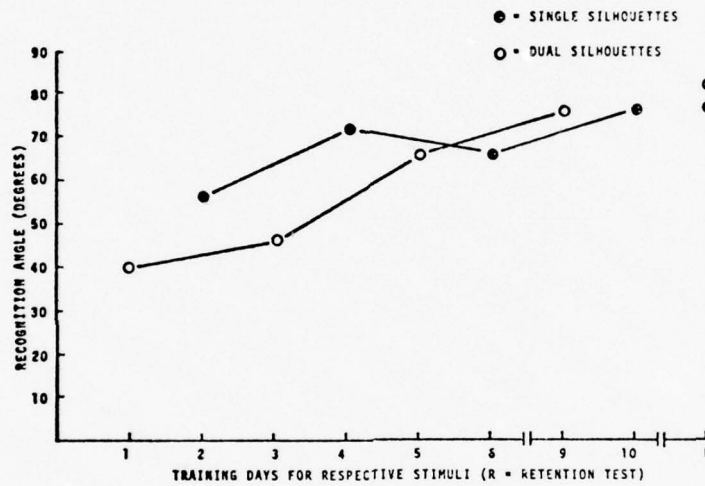

Figure 9. Subject 2.

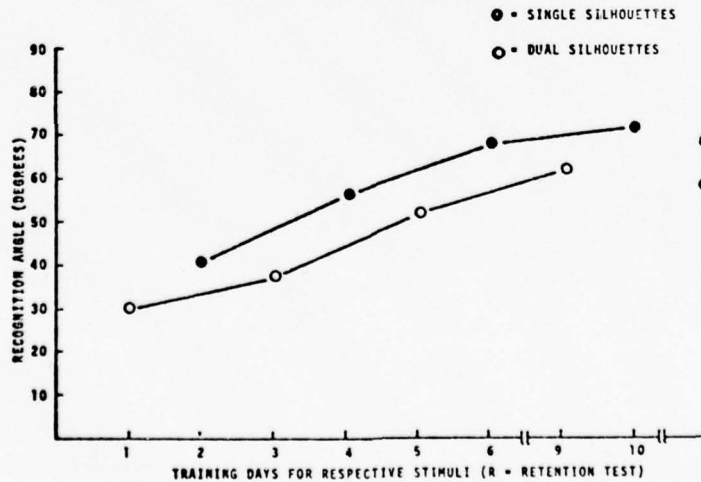

Figure 10. Subject 3.

Figures 8-10. Training performance with large (5.0°) single and dual silhouettes for individual experimental subjects 1, 2, and 3.

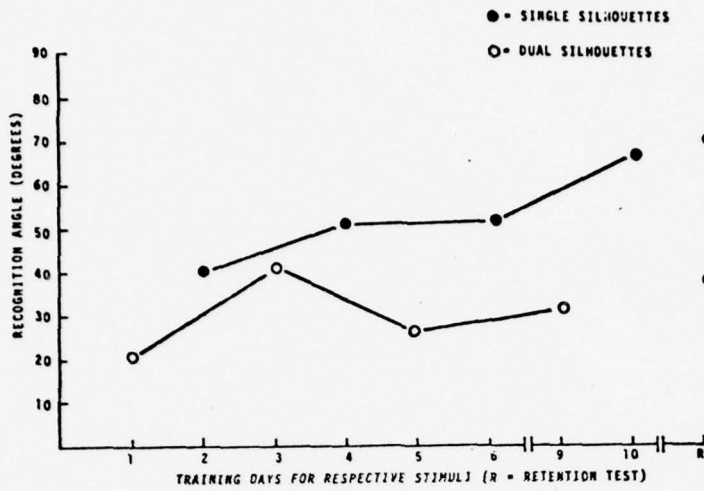

Figure 11. Subject 4.

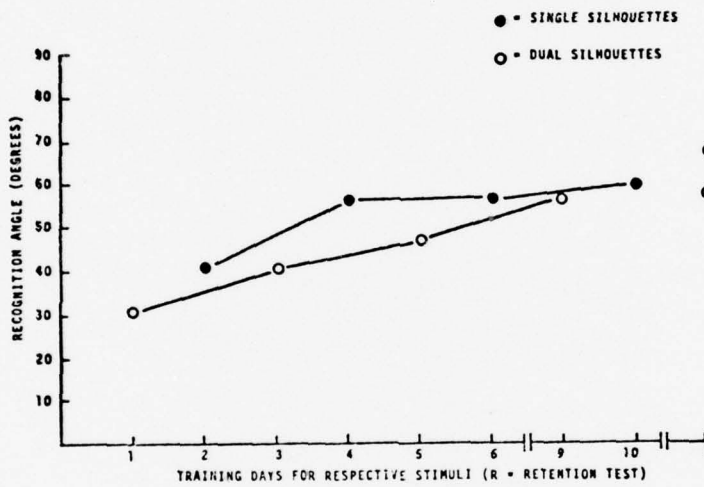

Figure 12. Subject 5.

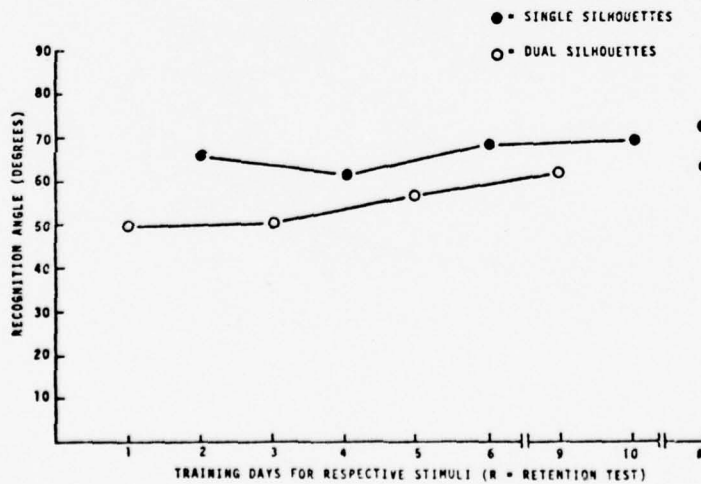

Figure 13. Subject 6

Figures 11-13. Training performance with large (5.0°) single and dual silhouettes for individual experimental subjects 4, 5, and 6.

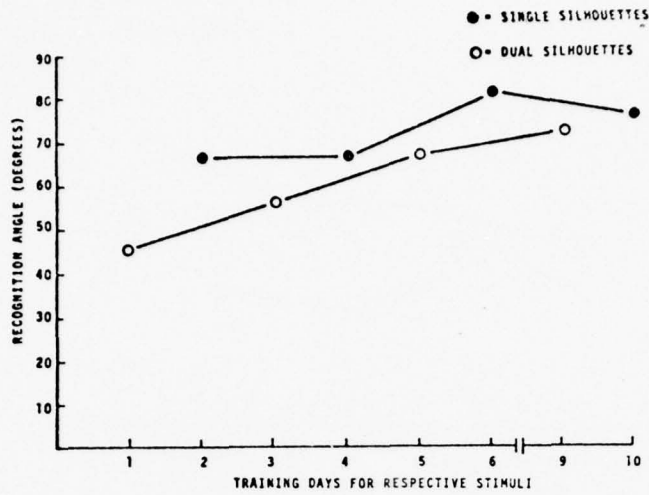

Figure 14. Subject 7.

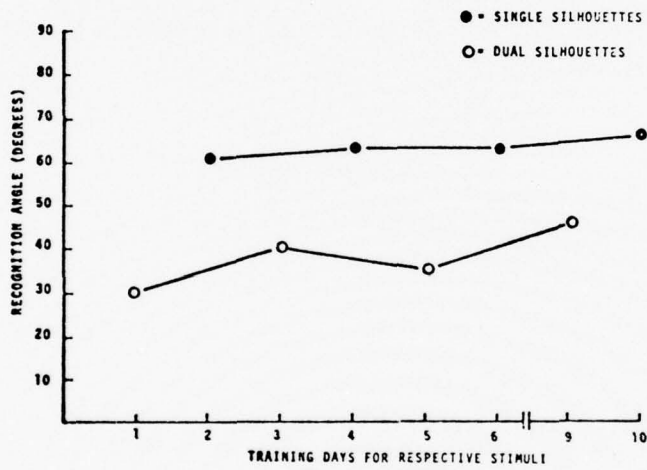

Figure 15. Subject 8.

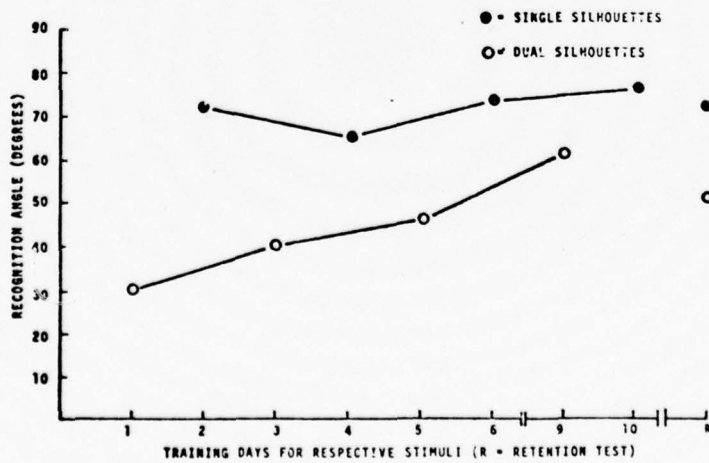

Figure 16. Subject 9.

Figures 14-16. Training performance with large (5.0°) single and dual silhouettes for individual experimental subjects 7, 8, and 9.

While the individual scores are more variable than the group data, the general increase in performance over days of training can readily be seen.

Kinetic Perimetry Test - Experimental Subjects

The mean kinetic perimetry scores for the nine experimental subjects for each day of training are shown in Figure 17. Since there were no significant differences between the scores for the two sides of presentation, the scores from the left and right sides and the two tests (pre- and post-session) for each day have been averaged. The mean angular difference between performance on the first and last days of training was 32.4° . The average performance difference between the pre-session and post-session kinetic perimetry tests for each training day was 4.1° . The kinetic perimetry score at the end of each training day was always better than the score at the beginning of that day. ANOVA confirmed the significance of the improvement in the kinetic perimetry scores from day to day ($df = 9, 72$; $F = 37.1$; $P < .01$). The difference between the kinetic perimetry scores at the beginning and end of each training session was also significant ($df = 1, 8$; $F = 28.61$; $P < .01$), as well as the interaction of training day and pre/posttraining testing ($df = 9, 72$; $F = 10.3$; $P < .05$).

Figure 18 shows the average daily and retention scores for the kinetic perimetry for the subjects who returned for testing. Consistent with the training performance data, the average retention score for kinetic perimetry approximately equaled the average test score achieved on the last day of training. It should be noted that during retention testing by kinetic perimetry only a single test at the beginning of the testing session was administered. Thus the retention score is free from any warm-up or practice effects that may have resulted from exposure to the silhouette recognition testing.

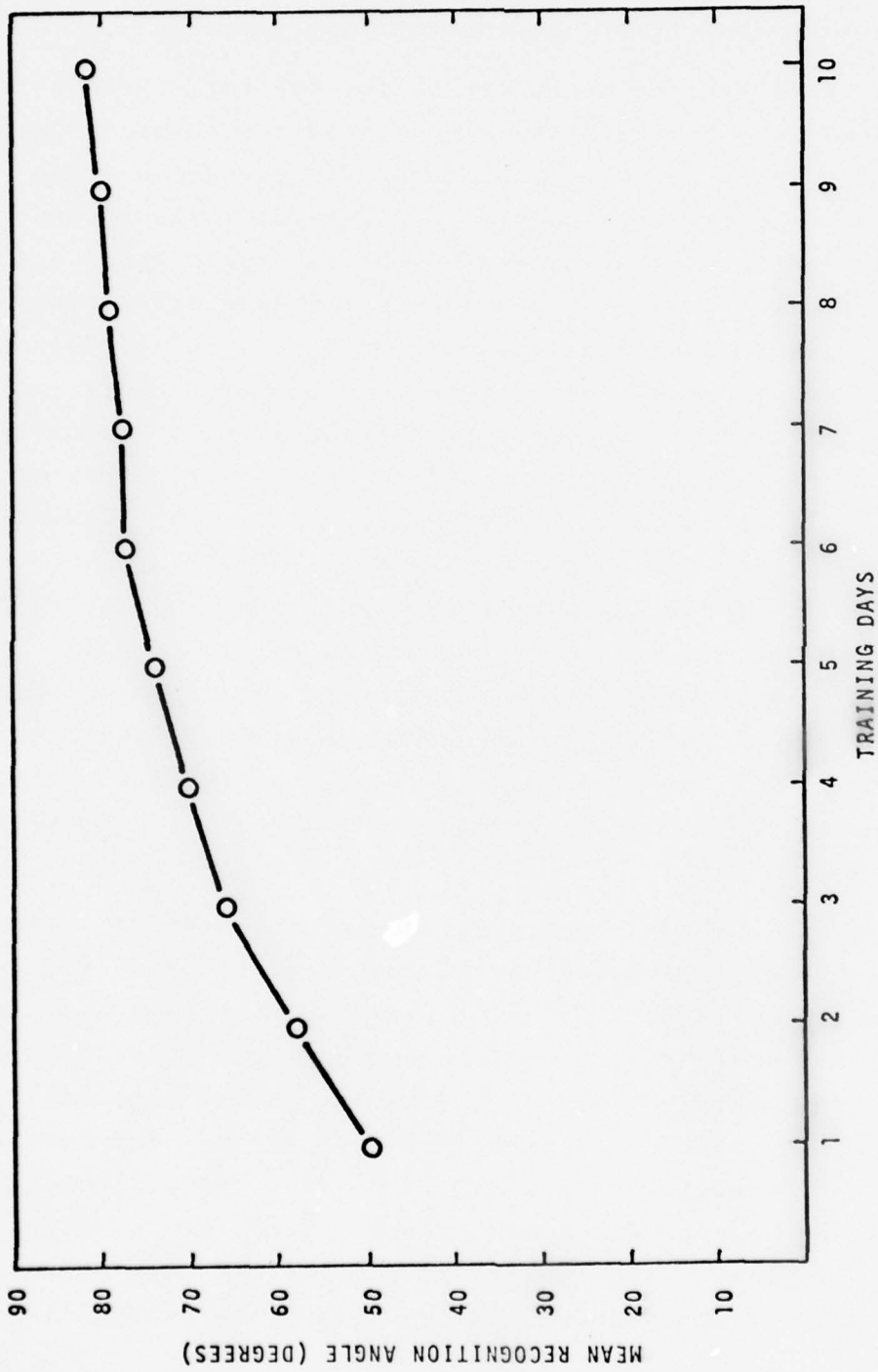

Figure 17. Kinetic perimetry performance with small (2.4°) single silhouettes for all experimental subjects ($N = 9$).

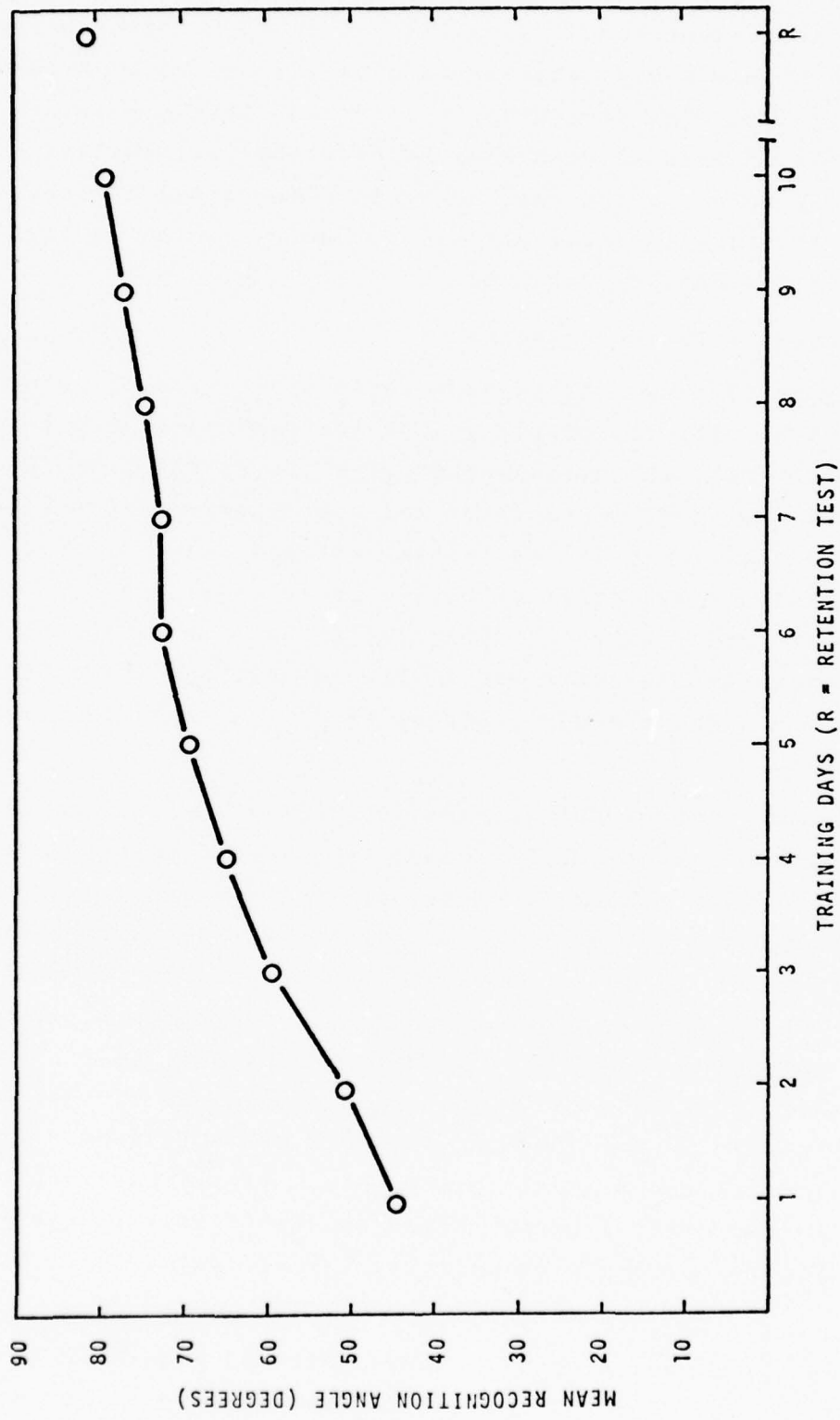

Figure 18. Kinetic perimetry performance with small (2.4°) single silhouettes for the experimental subjects tested for retention (N = 7).

The kinetic perimetry scores for each day of training for the nine experimental subjects and the retention scores for each of the seven subjects retested are shown in Figures 19 through 27. The increasing trends are clearly evident though the individual data show considerable variability. It is also worth noting that several subjects experienced a rapid increase in their kinetic perimetry scores during the first few days of training.

Test Results - Control Subjects

Figure 28 shows the average peripheral angle of recognition scores for the single-silhouette testing of the group of five control subjects together with the scores from the first and last days of training for the experimental subjects. The control subjects had an initial average score of 59.2° and a final average score of 56.2° , an average decrement of 3° in performance which was not statistically significant. The experimental subjects had an initial average score of 55.4° and a final average score of 69.5° , an improvement of 14.1° .

Figure 29 shows the average peripheral angle of recognition scores for the dual-silhouette recognition test for the five control subjects, along with the average scores from the first and last days of training for the experimental subjects. The control subjects had a score of 26° on both tests. On the first day of training the experimental group had an average score of 35.4° , and on the final day of training a score of 57.8° . This pattern of change is similar to that obtained for the single-silhouette presentations. In both cases the experimental group showed significant improvement, and the control group showed no significant change in their ability to recognize peripherally presented silhouettes.

The average kinetic perimetry scores for the five control subjects and the average scores for the first and last days of training for the nine experimental subjects are shown

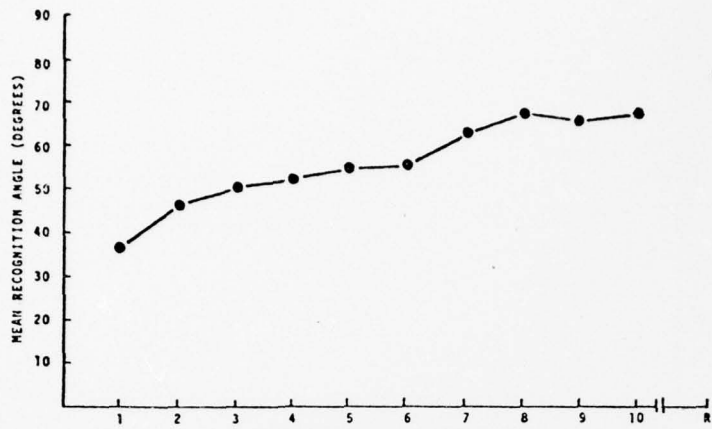

TRAINING DAYS (R = RETENTION TEST)
Figure 19. Subject 1.

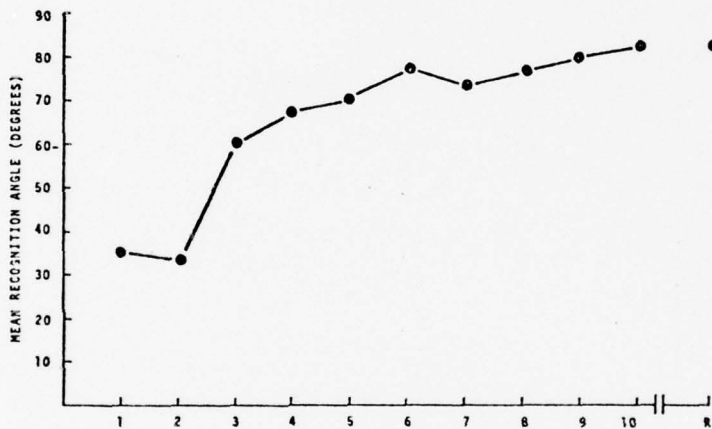

TRAINING DAYS (R = RETENTION TEST)
Figure 20. Subject 2.

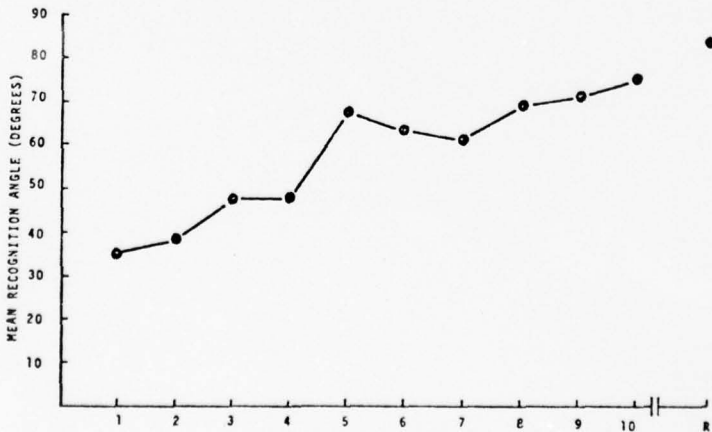

TRAINING DAYS (R = RETENTION TEST)
Figure 21. Subject 3.

Figures 19-21. Kinetic perimetry performance with small (2.4°) single silhouettes for individual experimental subjects 1, 2, and 3.

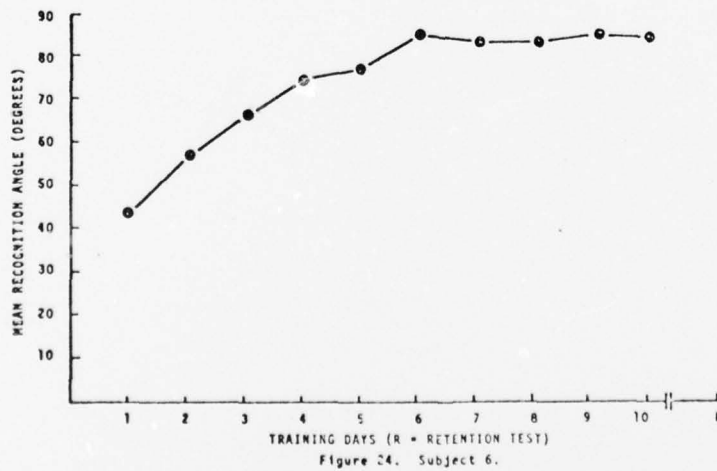
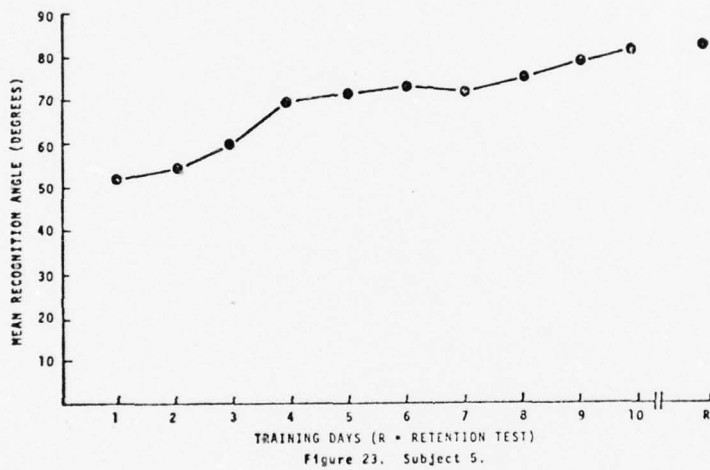
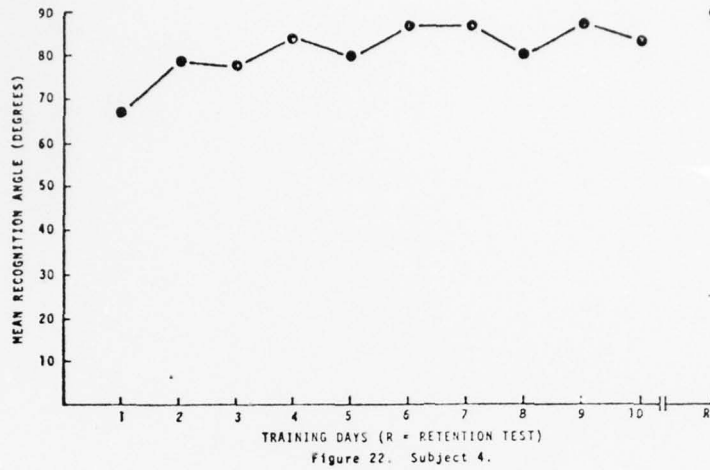

Figures 22-24. Kinetic perimetry performance with small (2.4°) single silhouettes for individual experimental subject 4, 5, and 6.

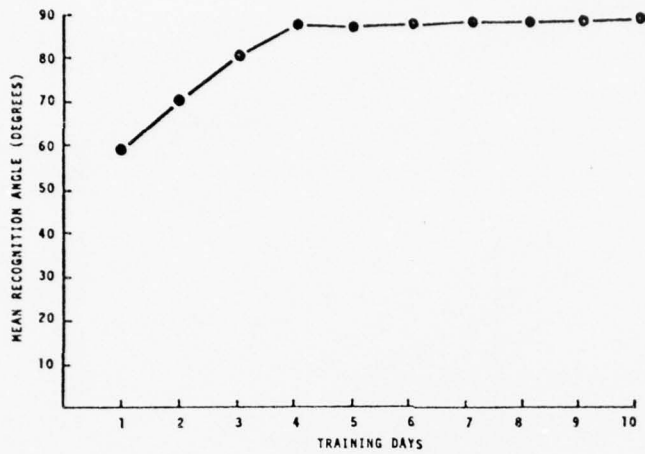

Figure 25. Subject 7.

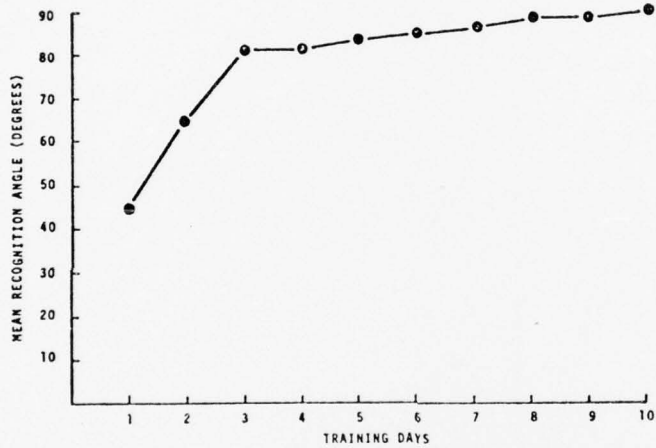

Figure 26. Subject 8.

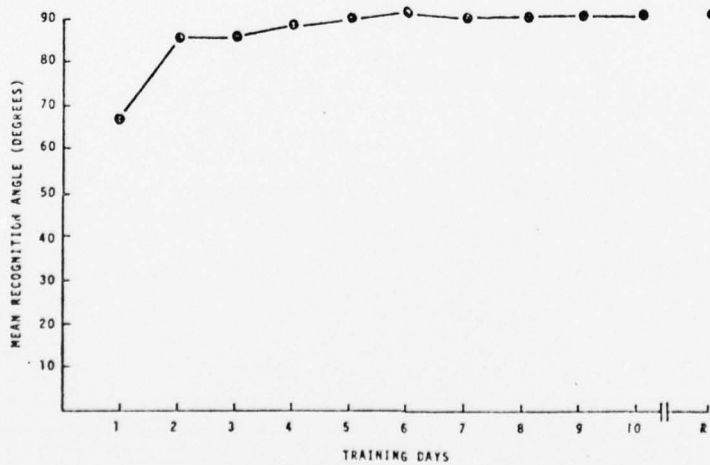

Figure 27. Subject 9.

Figures 25-27. Kinetic perimetry performance with small (2.4°) single silhouettes for individual experimental subjects 7, 8, and 9.

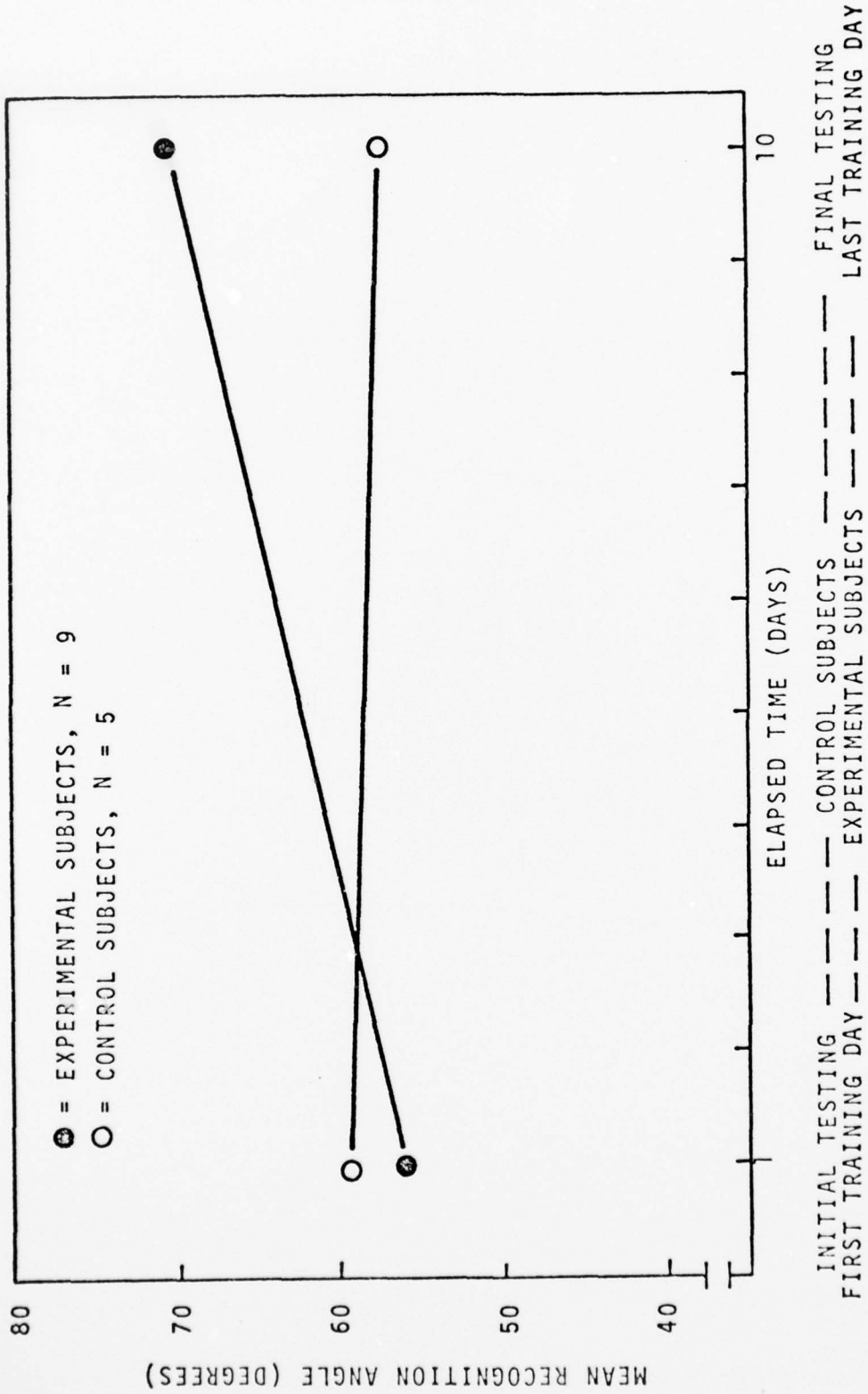

Figure 28. Performance changes from initial to final testing with large (5.0°) single silhouettes for experimental and control subjects.

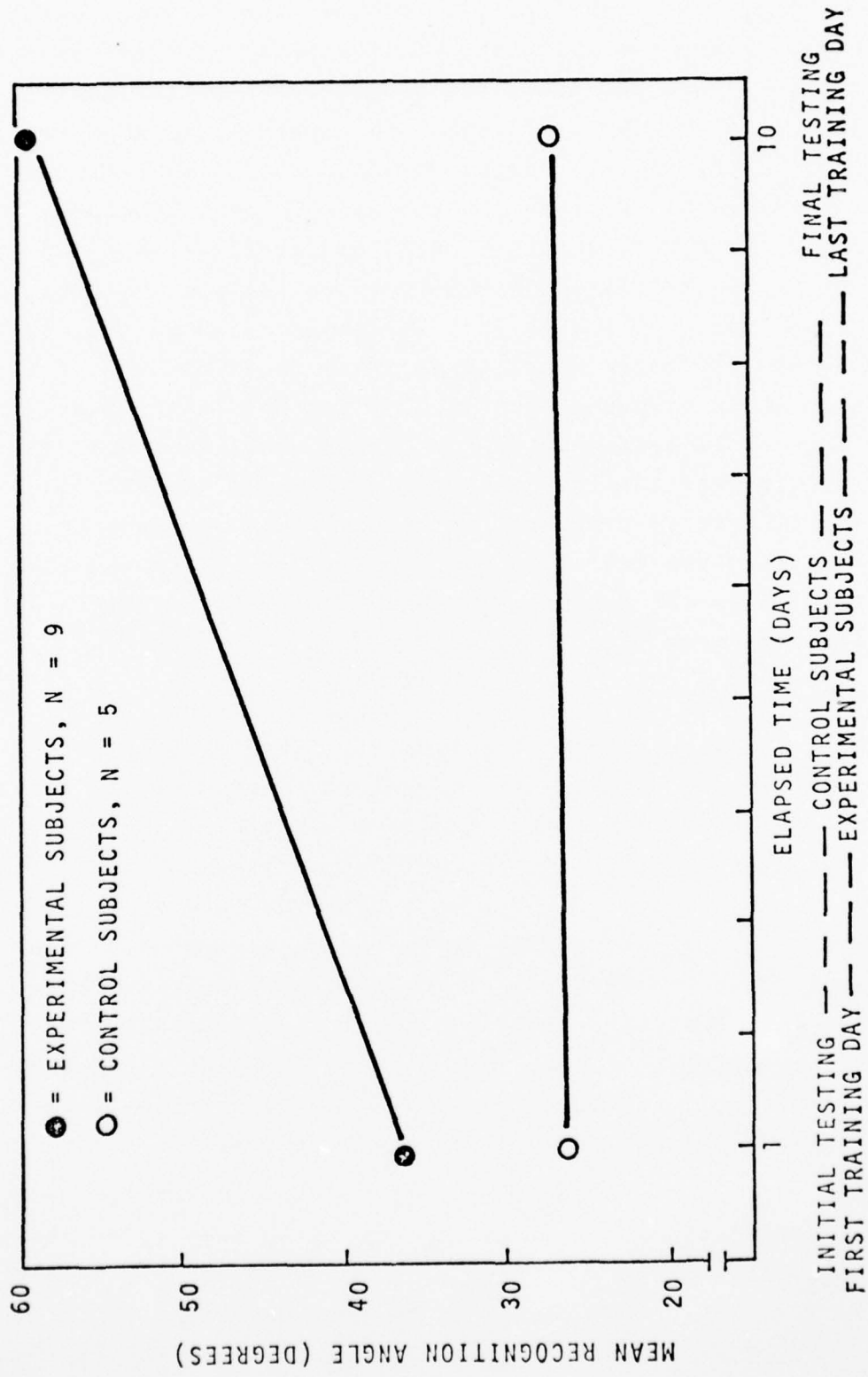

Figure 29. Performance changes from initial to final testing with large (5.0°) dual silhouettes for experimental and control subjects.

in Figure 30. The kinetic perimetry scores were computed by averaging the beginning-of-session and end-of-session scores. This procedure was applied to both the control and experimental subjects' data. The average angle of recognition of the kinetic targets by the control subjects was initially greater than for the experimental subjects. The control subjects averaged 63.7° on the first test and 68.9° on the second test. This difference was not statistically significant. The experimental subjects had an average kinetic perimetry score of 49.2° on the first day of training and an average score of 81.5° on the last day of training. It is evident that the experimental subjects' ability to recognize kinetic silhouettes improved substantially over the 10 days of training, and their final performance clearly surpassed the performance of control subjects. As indicated previously all performance changes for the experimental subjects were significant.

Mark I Tests

The nine experimental subjects were given eight selected tests incorporated in the Mark I Integrated Vision Tester (described in Appendix A) before and after the training course. Four control subjects were also administered the same test on two occasions with a 10-day interval between the tests. The static acuity scores for both the experimental and control subjects are shown in Table 4. The scores are in Snellen notation. The scoring criterion was the ability to resolve the gap orientation in four out of six Landolt rings of a given size. The static acuity of the experimental and control subjects was not significantly different.

For the movement tests (CAM, CMD, PAM, PMD), the total number of targets, out of 20, correctly identified and the threshold angular movement in minutes of arc per second were scored. The total number of targets correctly identified is shown in the columns labeled TOT in Tables 5 and 6. The threshold angular movement scores are shown in the columns

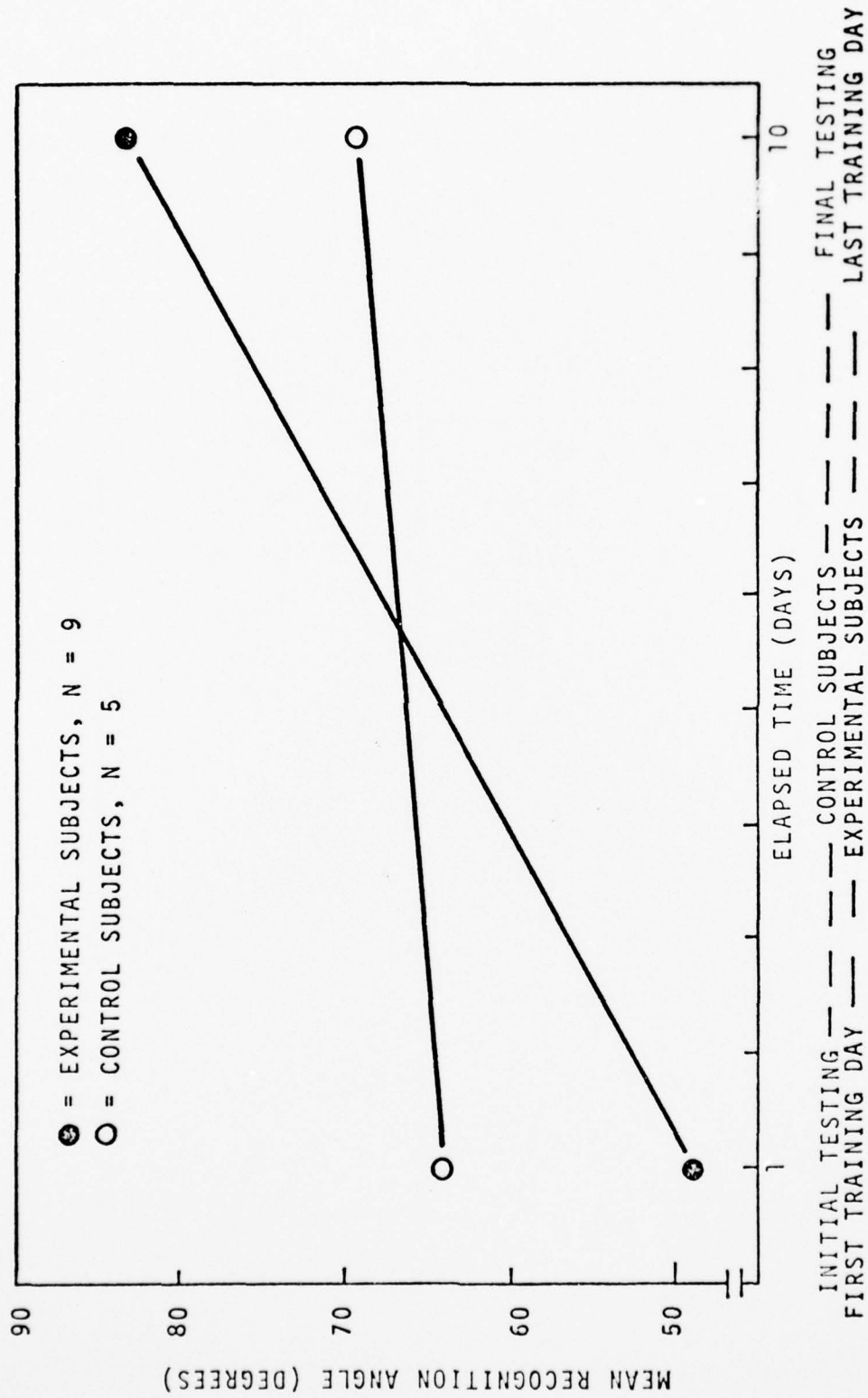

Figure 30. Kinetic perimetry performance changes from initial to final testing with small (2.4°) single silhouettes for experimental and control subjects.

TABLE 4
ACUITY SCORES FROM MARK I VISION TESTER
FOR EXPERIMENTAL AND CONTROL SUBJECTS

EXPERIMENTAL SUBJECTS		CONTROL SUBJECTS	
1	20/20	1	20/25*
2	20/20*	2	20/30*
3	20/35	3	20/20*
4	20/20*	4	20/30
5	20/25*		
6	20/25**		
7	20/20*		
8	20/35*		
9	20/35*		

*Glasses worn
**Arrested glaucoma

TABLE 5
 MARK I VISION TEST SCORES - EXPERIMENTAL SUBJECTS

		PRE-TRAINING SCORES																													
SUB#		CAM				CMD				PAM				PMD				FOV				DI90				DI35					
		TOT	THSH	TOT	SMAL	LARG	TOT	THSH	TOT	SMAL	LARG	TOT	LEFT	RIGHT	TOT	SMAL	LARG	TOT	LEFT	RIGHT	TOT	LEFT	RIGHT	TOT	LEFT	RIGHT	TOT	LEFT	RIGHT	TOT	LEFT
1		18.0	4.0	19.0	2.0	6.0	13.0	16.0	14.0	8.0	12.0	14.0	90.0	90.0	11.0	90.0	60.0	60.0	60.0	60.0	60.0	60.0	12.0	35.0	35.0	14.0	35.0	35.0			
2		9.0	32.0	12.0	16.0	16.0	3.0	256.0	9.0	12.0	128.0	12.0	90.0	80.0	10.0	80.0	80.0	80.0	80.0	80.0	80.0	80.0	10.0	35.0	35.0	14.0	35.0	35.0			
3		10.0	64.0	12.0	6.0	64.0	3.0	255.0	8.0	12.0	64.0	12.0	90.0	80.0	6.0	80.0	80.0	80.0	80.0	80.0	80.0	80.0	9.0	35.0	35.0	14.0	35.0	35.0			
4		18.0	4.0	16.0	2.0	16.0	8.0	64.0	19.0	44.0	64.0	14.0	90.0	90.0	4.0	80.0	90.0	90.0	90.0	90.0	90.0	90.0	4.0	35.0	35.0	14.0	35.0	35.0			
5		16.0	12.0	17.0	2.0	12.0	15.0	8.0	15.0	8.0	8.0	10.0	70.0	80.0	6.0	60.0	60.0	60.0	60.0	60.0	60.0	60.0	7.0	35.0	35.0	14.0	35.0	35.0			
6		15.0	12.0	16.0	12.0	2.0	12.0	32.0	13.0	12.0	8.0	13.0	90.0	80.0	13.0	90.0	80.0	80.0	80.0	80.0	80.0	80.0	13.0	35.0	35.0	14.0	35.0	35.0			
7		14.0	16.0	15.0	4.0	12.0	13.0	16.0	4.0	190.0	128.0	10.0	80.0	80.0	7.0	80.0	80.0	80.0	80.0	80.0	80.0	80.0	7.0	35.0	35.0	14.0	35.0	35.0			
8		14.9	15.0	15.6	3.8	15.8	10.9	76.4	11.6	34.7	48.0	11.7	84.4	82.2	7.3	76.7	71.1	12.2	35.0	33.3	33.3	7.3	12.2	35.0	14.0	35.0	35.0				
MEAN		16.0	12.0	16.0	4.0	12.0	13.0	32.0	13.0	12.0	12.0	12.0	90.0	80.0	7.0	80.0	70.0	13.0	35.0	35.0	35.0	7.0	13.0	35.0	14.0	35.0	35.0				
MDN																															
		POST-TRAINING SCORES																													
SUB#		CAM				CMD				PAM				PMD				FOV				DI90				DI35					
		TOT	THSH	TOT	SMAL	LARG	TOT	THSH	TOT	SMAL	LARG	TOT	LEFT	RIGHT	TOT	SMAL	LARG	TOT	LEFT	RIGHT	TOT	LEFT	RIGHT	TOT	LEFT	RIGHT	TOT	LEFT	RIGHT	TOT	LEFT
1		14.0	15.0	19.0	2.0	12.0	18.0	2.0	14.0	12.0	16.0	14.0	90.0	90.0	13.0	90.0	80.0	80.0	80.0	80.0	80.0	80.0	13.0	35.0	35.0	14.0	35.0	35.0			
2		18.0	4.0	20.0	2.0	2.0	11.0	64.0	12.0	128.0	2.0	12.0	80.0	80.0	12.0	80.0	80.0	80.0	80.0	80.0	80.0	80.0	12.0	35.0	35.0	14.0	35.0	35.0			
3		11.0	64.0	19.0	2.0	12.0	8.0	64.0	12.0	32.0	128.0	12.0	80.0	80.0	12.0	80.0	80.0	80.0	80.0	80.0	80.0	80.0	12.0	35.0	35.0	14.0	35.0	35.0			
4		15.0	16.0	19.0	2.0	4.0	16.0	8.0	16.0	16.0	16.0	13.0	90.0	80.0	12.0	80.0	80.0	80.0	80.0	80.0	80.0	80.0	12.0	35.0	35.0	14.0	35.0	35.0			
5		19.0	2.0	18.0	6.0	4.0	17.0	12.0	10.0	190.0	190.0	12.0	80.0	70.0	8.0	90.0	60.0	60.0	60.0	60.0	60.0	60.0	8.0	35.0	35.0	14.0	35.0	35.0			
6		15.0	32.0	16.0	2.0	32.0	12.0	16.0	16.0	16.0	8.0	11.0	80.0	80.0	10.0	80.0	70.0	70.0	70.0	70.0	70.0	70.0	10.0	35.0	35.0	14.0	35.0	35.0			
7		13.0	12.0	17.0	6.0	6.0	16.0	16.0	18.0	12.0	2.0	11.0	80.0	80.0	8.0	80.0	70.0	70.0	70.0	70.0	70.0	70.0	8.0	35.0	35.0	14.0	35.0	35.0			
8		17.0	8.0	20.0	2.0	2.0	15.0	16.0	13.0	2.0	128.0	14.0	90.0	90.0	8.0	80.0	70.0	70.0	70.0	70.0	70.0	70.0	8.0	35.0	35.0	14.0	35.0	35.0			
9		13.0	16.0	16.0	6.0	8.0	13.0	15.0	13.0	2.0	128.0	14.0	90.0	90.0	8.0	80.0	70.0	70.0	70.0	70.0	70.0	70.0	8.0	35.0	35.0	14.0	35.0	35.0			
MEAN		15.0	16.9	17.8	3.3	9.1	14.0	22.9	13.4	66.4	68.7	12.4	84.4	83.3	10.2	85.6	73.3	13.6	35.0	34.4	34.4	10.2	13.6	35.0	14.0	35.0	35.0				
MDN		15.0	16.0	18.0	2.0	6.0	15.0	12.0	13.0	16.0	16.0	12.0	80.0	80.0	10.0	80.0	80.0	80.0	80.0	80.0	80.0	80.0	10.0	35.0	35.0	14.0	35.0	35.0			
		DIFFERENCE SCORES (POST-PRE)																													
SUB#		CAM				CMD				PAM				PMD				FOV				DI90				DI35					
		TOT	THSH	TOT	SMAL	LARG	TOT	THSH	TOT	SMAL	LARG	TOT	LEFT	RIGHT	TOT	SMAL	LARG	TOT	LEFT	RIGHT	TOT	LEFT	RIGHT	TOT	LEFT	RIGHT	TOT	LEFT	RIGHT	TOT	LEFT
1		-4.0	12.0	0.0	0.0	6.0	5.0	-14.0	0.0	4.0	4.0	0.0	0.0	0.0	0.0	0.0	0.0	0.0	0.0	0.0	0.0	2.0	0.0	0.0	2.0	0.0	0.0	0.0	0.0	0.0	
2		9.0	-28.0	8.0	-14.0	-14.0	8.0	-192.0	3.0	116.0	-126.0	0.0	-10.0	0.0	0.0	-10.0	10.0	10.0	10.0	10.0	10.0	3.0	0.0	0.0	6.0	0.0	5.0	0.0	0.0	0.0	
3		1.0	0.0	3.0	0.0	-52.0	5.0	-192.0	4.0	20.0	64.0	0.0	-10.0	0.0	0.0	0.0	0.0	0.0	0.0	0.0	0.0	0.0	0.0	0.0	0.0	0.0	0.0	0.0	0.0	0.0	
4		-1.0	10.0	3.0	-4.0	-2.0	0.0	0.0	0.0	4.0	4.0	6.0	10.0	10.0	0.0	0.0	0.0	0.0	0.0	0.0	0.0	4.0	0.0	0.0	4.0	0.0	0.0	0.0	0.0	0.0	
5		1.0	-2.0	0.0	4.0	-12.0	9.0	-52.0	1.0	126.0	126.0	-2.0	-10.0	-20.0	0.0	0.0	0.0	0.0	0.0	0.0	0.0	3.0	0.0	0.0	3.0	0.0	0.0	0.0	0.0	0.0	
6		-3.0	0.0	1.0	-6.0	4.0	4.0	-20.0	5.0	0.0	-6.0	-2.0	-10.0	0.0	0.0	0.0	0.0	0.0	0.0	0.0	0.0	-3.0	0.0	0.0	-3.0	0.0	0.0	0.0	0.0	0.0	
7		3.0	-8.0	5.0	-2.0	-10.0	2.0	0.0	6.0	0.0	0.0	4.0	10.0	10.0	0.0	0.0	0.0	0.0	0.0	0.0	0.0	8.0	0.0	0.0	8.0	0.0	0.0	0.0	0.0	-5.0	
8		-3.0	4.0	-1.0	4.0	0.0	-2.0	-16.0	-3.0	-10.0	120.0	1.0	10.0	0.0	1.0	10.0	0.0	0.0	0.0	0.0	0.0	1.0	0.0	0.0	1.0	0.0	0.0	0.0	0.0	0.0	
9		1.2	1.9	2.2	-2.0	-6.7	3.1	-53.6	1.9	29.8	20.7	1.8	0.0	1.1	2.9	8.9	2.2	1.3	0.0	1.1	1.1	2.9	8.9	2.2	1.3	0.0	1.1	1.1	1.1	1.1	
MEAN																															
MDN		-1.0	0.0	2.0	0.0	-2.0	4.0	-16.0	1.0	4.0	4.0	0.0	0.0	0.0	0.0	0.0	0.0	0.0	0.0	0.0	0.0	3.0	10.0	0.0	3.0	10.0	0.0	1.0	0.0	0.0	
		D = Decrease, I = Increase, - = No change in performance																													

TABLE 6
MARK I VISION TEST SCORES - CONTROL SUBJECTS

SUB#	PRETRAINING SCORES																				
	CAM			CMD			PAM			PMD			FOV			D190			D135		
	TOT	THSH	TOT	TOT	SMAL	LARG	TOT	THSH	TOT	TOT	SMAL	LARG	TOT	LEFT	RIGHT	TOT	LEFT	RIGHT	TOT	LEFT	RIGHT
1	17.0	32.0	20.0	2.0	2.0	2.0	17.0	12.0	18.0	16.0	16.0	8.0	14.0	80.0	80.0	10.0	80.0	80.0	14.0	35.0	35.0
2	16.0	6.0	16.0	4.0	12.0	13.0	10.0	12.0	13.0	12.0	12.0	64.0	10.0	80.0	80.0	7.0	80.0	60.0	12.0	35.0	30.0
3	14.0	16.0	19.0	4.0	2.0	2.0	17.0	32.0	15.0	128.0	4.0	11.0	80.0	80.0	80.0	9.0	60.0	90.0	14.0	35.0	35.0
4	13.0	128.0	14.0	8.0	12.0	14.0	11.0	22.0	14.0	32.0	16.0	11.0	90.0	80.0	70.0	11.0	80.0	80.0	12.0	35.0	35.0
MEAN	14.5	45.5	17.2	4.5	7.0	7.0	13.7	20.5	15.0	47.0	23.0	11.5	85.0	80.0	80.0	9.2	75.0	77.5	13.0	35.0	33.7
MDN	14.5	24.0	17.5	4.0	7.0	7.0	14.0	19.0	14.5	24.0	12.0	11.0	85.0	80.0	80.0	9.5	80.0	80.0	13.0	35.0	35.0

SUB#	POST-TRAINING SCORES																				
	CAM			CMD			PAM			PMD			FOV			D190			D135		
	TOT	THSH	TOT	TOT	SMAL	LARG	TOT	THSH	TOT	TOT	SMAL	LARG	TOT	LEFT	RIGHT	TOT	LEFT	RIGHT	TOT	LEFT	RIGHT
1	17.0	6.0	19.0	2.0	6.0	6.0	15.0	16.0	20.0	2.0	2.0	14.0	90.0	90.0	90.0	14.0	90.0	90.0	14.0	35.0	35.0
2	17.0	6.0	18.0	2.0	6.0	6.0	16.0	16.0	13.0	32.0	190.0	10.0	80.0	80.0	80.0	10.0	80.0	70.0	13.0	35.0	35.0
3	13.0	16.0	19.0	6.0	2.0	2.0	12.0	128.0	12.0	64.0	16.0	9.0	80.0	80.0	80.0	10.0	80.0	60.0	13.0	35.0	35.0
4	16.0	12.0	18.0	4.0	4.0	4.0	10.0	64.0	17.0	32.0	2.0	13.0	90.0	80.0	80.0	9.0	80.0	60.0	13.0	35.0	35.0
MEAN	15.7	10.0	18.5	3.5	4.5	4.5	13.3	55.0	15.5	52.5	52.5	11.5	85.0	82.5	70.0	10.7	82.5	70.0	13.3	35.0	35.0
MDN	15.5	9.0	18.5	3.0	5.0	5.0	13.5	40.0	15.0	32.0	9.0	11.5	85.0	80.0	65.0	10.0	80.0	65.0	13.0	35.0	35.0

SUB#	DIFFERENCE SCORES (POST-PRE)																				
	CAM			CMD			PAM			PMD			FOV			D190			D135		
	TOT	THSH	TOT	TOT	SMAL	LARG	TOT	THSH	TOT	TOT	SMAL	LARG	TOT	LEFT	RIGHT	TOT	LEFT	RIGHT	TOT	LEFT	RIGHT
1	4.0	-26.0	-1.0	0.0	4.0	4.0	-2.0	4.0	2.0	-14.0	-6.0	0.0	0.0	0.0	0.0	4.0	10.0	10.0	0.0	0.0	0.0
2	1.0	0.0	2.0	-2.0	-2.0	-6.0	6.0	0.0	0.0	20.0	126.0	0.0	0.0	0.0	0.0	2.0	0.0	10.0	1.0	0.0	5.0
3	-3.0	0.0	0.0	2.0	0.0	0.0	-5.0	96.0	-3.0	-64.0	12.0	-2.0	0.0	0.0	0.0	1.0	20.0	-30.0	-1.0	0.0	0.0
4	3.0	-116.0	4.0	-4.0	-8.0	-8.0	-1.0	42.0	3.0	0.0	-14.0	2.0	0.0	0.0	10.0	-2.0	0.0	-20.0	1.0	0.0	0.0
MEAN	1.5	-35.5	1.5	-1.0	-1.0	-2.5	-1.5	35.5	1.5	-14.5	29.5	0.0	0.0	0.0	2.5	1.5	7.5	-7.5	1.3	0.0	1.3
	I	I	I	I	I	I	D	D	I	I	D	D	-	-	I	I	D	I	I	-	I

MDN	2.0	-13.0	1.0	-1.0	-3.0	-3.0	1.0	23.0	1.0	-7.0	3.0	0.0 <th>0.0<th>0.0<th>0.0 <th>2.0</th><th>5.0</th><th>-5.0</th> <th>.5</th><th>0.0</th><th>0.0</th> </th></th></th>	0.0 <th>0.0<th>0.0 <th>2.0</th><th>5.0</th><th>-5.0</th> <th>.5</th><th>0.0</th><th>0.0</th> </th></th>	0.0 <th>0.0 <th>2.0</th><th>5.0</th><th>-5.0</th> <th>.5</th><th>0.0</th><th>0.0</th> </th>	0.0 <th>2.0</th> <th>5.0</th> <th>-5.0</th> <th>.5</th> <th>0.0</th> <th>0.0</th>	2.0	5.0	-5.0	.5	0.0	0.0
	I	I	I	I	I	I	D	D	I	I	D	D	-	-	-	I	I	D	I	-	-

D = Decrease, I = Increase, - = No change in performance

labeled THSH for the CAM and the PAM scores, and SMAL and LARG for the CMD and the PMD tests. For these two tests the threshold for detecting targets decreasing in size and for targets increasing in size were scored separately. The criterion for the threshold angular movement test (CAM and PAM) was the smallest angular movement before two misses at the next slower speed, or if only one miss occurred at a particular rate of movement followed by another miss at a lower rate of movement, the score would be the movement rate for the target with the next greater movement rate than the second target missed. If there was only one miss on the entire test, the threshold score was the movement rate for the slowest target which was correctly recognized twice. If the only miss occurred at the slowest movement rate, that rate was taken as the score.

The criterion for the movement-in-depth test was the movement rate for the target which was greater than the first target missed. The targets which decreased in size and increased in size were scored separately according to the same criterion. For the field of view (FOV) and detection, acquisition, and interpretation 90° (DAI-90), the score was the largest peripheral angle at which two of the targets were correctly recognized. The left and right sides were scored separately. If the subject did not have two correct recognitions at any angle between 60° and 90°, he received a score of 60° if there was at least one correct detection at that angle. The score for the detection, acquisition, and interpretation 35° (DAI-35) was the most extreme peripheral angle at which a target was correctly recognized. The left and right eyes were scored separately. A total correct target score was generated for each of the tests. The maximum obtainable score for the movement tests was 20 and for the FOV and DAI tests it was 14.

Tables 5 and 6 show the results of the first Mark I test, the second Mark I test, and the differences between scores on

the two tests. Means and medians for these three sets of scores are also given. Beneath each mean and median difference score is an I or D which represents an Increase or Decrease in performance, respectively. Note that a minus difference score indicates improvement for some of the tests.

A T test was computed for each of the pre- and posttest results for both groups. No significant differences at the .05 level of confidence were found.

DISCUSSION

It is evident from the data on the single- and dual-silhouette recognition training tasks and the kinetic perimetry test that the experimental subjects, as a group, experienced substantial improvement in their peripheral function for these tasks. The experimental subjects showed an increase of their total horizontal visual field of 28.2° and 44.4° for the single- and dual-silhouette recognition tasks, respectively. On the kinetic perimetry test the experimental subjects increased their total horizontal visual field by 64.6°. The control subjects, on the other hand, showed no significant improvement on either the silhouette recognition tasks or the kinetic perimetry test. These results confirm the efficacy of the training procedure for improving peripheral recognition of silhouettes.

It is interesting that improvement on the dual-silhouette recognition task was greater than for the single-silhouette recognition task. However, it is probable that the difference in the amount of improvement on these two tasks simply reflects a ceiling effect. That is, as the physiological limits of peripheral vision (approximately 90° to the right and left) are approached, it becomes more difficult to cause improvements of a consistent angular amount. Since the single-silhouette angle of recognition was always closer to the physiological limit, the absolute improvement would be expected

to be less on this task than on the dual-silhouette recognition task.

The greatest amount of improvement in peripheral performance was on the kinetic perimetry test. Under the condition of unlimited exposure time, the smaller kinetic perimetry silhouettes were recognized at about 88° on the left and right at the end of the training course. This is equivalent to a 64° increase of the total horizontal field. Improvements on the kinetic perimetry test are probably not indicative of transfer from the single- and dual-silhouette recognition tasks because performance on the kinetic perimetry test generally shows a faster rate of improvement over the days of training than the training tasks themselves. Because of the length of time devoted to kinetic perimetry testing and the fact that the subjects received feedback on their performance, taking the kinetic perimetry test may be regarded as a form of training in itself. The control subjects showed a slight but nonsignificant improvement in their kinetic perimetry scores after the equivalent of 2 days of training. From these results it can be concluded that the improvements in the kinetic perimetry scores by the experimental group are not solely a function of familiarization.

In general, the experimental subjects' performance showed a gradual increase over the 10-day training period. The improvement on the single- and dual-silhouette recognition tasks showed a general linear trend. It is likely that continuation of the training course would have resulted in further improvements on these two tasks. The kinetic perimetry performance data show a more rapid increase, approaching the physiological limit after approximately 6 days, and a very slow rate of improvement thereafter.

The progress of the experimental subjects from day to day was fairly consistent, and there were almost no decreases in performance on successive days. This contrasts with the

results of the first experiment where very large fluctuations and substantial decreases in performance sometimes occurred as training continued.

It is probable that the efforts to motivate and encourage the subjects had a substantial effect on their performance. At the end of the training course all of the experimental subjects reported that they enjoyed participating in the experiment and never found it boring or fatiguing. Many of the subjects, when asked, reported anecdotally that they had noticed improvement in their peripheral vision outside of the training situation. One subject reported noticing movement of other vehicles in her rearview mirror while driving and was very surprised the first time she noticed it. Another subject reported that he noticed being distracted by events occurring in his peripheral field which, prior to the training course went unnoticed. These reports are interesting but should not be given a great deal of weight since the subjects were aware of the purpose of the experiment, and were specifically asked if they noticed any improvement in their peripheral vision.

The results of the retention tests on seven of the experimental subjects were somewhat surprising. After 60 days, performance on the single- and dual-silhouette recognition tasks and the kinetic perimetry test was almost equal to performance on the last day of training. Some savings in ability to perform these tasks was expected, but almost complete retention of the improvement was not.

The retention test protocol was deliberately structured to avoid, to the greatest extent possible, any retraining not inherent in the tasks themselves. The kinetic perimetry test was administered immediately at the beginning of the testing session. The subjects were not shown pictures of the silhouettes or given any other form of familiarization than the conduct of the test itself. The kinetic perimetry retention

scores, unlike the kinetic perimetry scores for the training days, were based on a single test score rather than on the average of a pre- and post-session kinetic perimetry score. The only other study of retention that we were able to find (Johnson & Leibowitz, 1974), which employed retention tests 1 month and 3 months after the conclusion of training, showed about a 30% loss in performance compared to the final training session. It seems reasonable to conclude from this previous study and the present work that there is a high probability of significant retention of the improvement of peripheral function gained through training.

It is doubtful that any of the improvements noted in these tasks were due to the failure of the subjects to maintain central fixation. The experimenter frequently cautioned the subjects to fixate straight ahead and occasionally, unknown to the subjects, glanced around the side of the apparatus to verify the general direction of fixation. The consistency of the data also tend to confirm that the subjects maintained fixation as instructed. The day-to-day results on the kinetic perimetry test showed no sharp changes which would be indicative of a failure to maintain fixation. Also, on the dual-silhouette task, there would be no advantage in looking to the left or the right since both silhouettes had to be correctly recognized in order for the angle of presentation to be advanced. But, most importantly, preliminary testing with a trained subject instructed to attempt to recognize the silhouettes foveally, by shifting fixation, indicated that the 250 msec. exposure duration actually produced decremental performance changes. It is therefore extremely doubtful that the improvements in peripheral vision were due to failure to maintain fixation.

The results of the tests performed using the Mark I Integrated Vision Tester do not offer any objective support for the hypothesis that improvement of vision through training transfers to a different testing situation. The scores

AD-A042 803

HUMAN FACTORS RESEARCH INC GOLETA CALIF
PERIPHERAL VISION TRAINING FOR MOTOR VEHICLE DRIVERS.(U)
JUN 77 R T HENNESSY, R E NEWTON
1767-F

F/G 5/9

DOT-HS-5-01204

UNCLASSIFIED

NL

2 of 3
ADA042803



obtained by the nine experimental subjects on the Mark I Integrated Vision Tester were comparable to those reported by Henderson and Burg (1974) for subjects 50 years of age and older. The failure of these tests, particularly the ones involving peripheral vision, to substantiate any transfer of peripheral training may be due to several causes. The most obvious explanation may be that training of a given peripheral function does not transfer to another peripheral function. Other than this, the apparent lack of reliability of the Mark I Integrated Vision Tester tests may also be responsible for the failure to find significant improvements. In testing with the Mark I, the number of data points gathered on each test is very low. Consequently, there is generally high variability of performance between subjects. This can be seen by looking at some of the individual scores in Table 5. Another indication of its variability is the inconsistency of improvements and decrements in performance from the pre-training to the posttraining tests. Therefore it appears that the Mark I Integrated Vision Tester may not be a very reliable instrument for revealing small or moderate changes in visual function. A previous study using this prototype device (Henderson & Burg, 1974) also found the reliability to be relatively low when the same individuals were tested on two separate occasions. When testing a large number of subjects, the group variability can be reduced to the point where differences in visual performance between subgroups of a population may be revealed. It is difficult, however, to obtain reliable individual visual performance scores when only a small number of trials is used for each test.

Because the experimental subjects showed no improvement in performance when tested with the Mark I Integrated Vision Tester, there was no compelling reason to test all control subjects with this device. Thus, only four control subjects were tested on two occasions with this device. Their average performance data, like those of the experimental subjects,

showed no significant changes from the first testing to the second.

An unexpected result of this experiment was the differences in performance between the experimental and control subjects on the first day of training and testing for the single-silhouette recognition task and kinetic perimetry test. The control subjects' average performance was superior to that of the experimental subjects on these two measures. The average age and distribution of ages of subjects in both groups were nearly identical. The only apparent difference between the two groups was that the experimental subjects came exclusively from a private retirement apartment complex while the control subjects came from the general population. The experimental subjects may have been slightly more weathered by age than the control subjects since the living conditions they have voluntarily chosen relieve them of certain responsibilities. For example, although each individual lives in his own apartment, the complex provides common dining facilities and a social director. The control subjects, on the other hand, live either in their own homes or in a standard apartment and generally take full responsibility for their own well-being. The retirement complex is in no sense a nursing or care-type facility, but generally the residents enjoy a small reduction in their responsibilities. While all but one of the experimental subjects owned their own automobile, they used them only occasionally. The control subjects, on the other hand, reported driving frequently and regularly. These differences in life experience may be reflected in their initial performance on the silhouette recognition task and the kinetic perimetry test.

All of the subjects enjoyed the peripheral training tasks of recognizing vehicular silhouettes. They could readily understand the apparent relationship between these tasks and improvement of drivers' peripheral vision. Varying the type of training tasks from day to day and use of the small, 2.4°

silhouettes on the seventh and eighth days of training appeared to sustain the interest and motivation of the subjects. The objective effect of using the small silhouettes on 2 of the training days is not known, but there does not appear to have been any general change in the rate of improvement on the large silhouette recognition tasks on subsequent training days. Several of the subjects commented, however, that the recognition of the larger silhouettes on the ninth and tenth days of training seemed much easier after exposure to 2 days of training using the small silhouettes.

Engaging in a running dialogue with each subject about what cues they were using to recognize the peripheral stimuli and offering encouragement to do well seemed to contribute a great deal to maintaining the subjects' interest and motivation. All of the subjects were quite willing to talk about what cues they thought they were using for recognition and would comment on their performance from trial to trial.

The training task became essentially a team effort with the subject and experimenter working toward a common goal. Often the subjects were reluctant to stop either for a break or at the end of the training session. Including a break and terminating the session on time, however, was strictly adhered to.

It may be that the running dialogue during training helped the subject by focusing his attention on the task at hand and prevented boredom or distraction of his thoughts. All of the subjects thought that the tasks were difficult. This was expected since they were always operating near their threshold of performance. The subjects' attitude, however, appeared to be one of enjoying a challenging game rather than being forced to perform an onerous task. It is difficult to objectively specify how freewheeling interaction between the subject and experimenter contributes to the improvement of peripheral vision function, but subjectively it appears to be a highly important and beneficial aspect of the procedure.

CONCLUSIONS

The major conclusions drawn from this experiment are:

1. Training improves performance in the peripheral recognition of vehicular silhouettes presented singly or in pairs for short durations.
2. Either training or practice also improves the ability to recognize moving vehicular silhouettes presented for unlimited exposure times.
3. Any generalized improvement in peripheral function as a result of training was not revealed by testing with the Mark I Integrated Vision Tester.
4. Maintaining the interest and motivation of the subjects by introducing some novelty and offering encouragement appeared to be an important part of peripheral vision training.

EXPERIMENT III

The previous experiment demonstrated that the recognition of peripherally presented vehicular silhouettes could be improved through training. The purpose of Experiment III was to determine if improvements in peripheral vision achieved through training would successfully transfer to the driving environment.

A group of experimental subjects was pretested during driving, given 10 days of peripheral training on vehicular silhouette recognition, and retested during driving with the silhouette recognition and motion detection tests. A group of control subjects was administered the tests during driving on two occasions separated by a time interval equivalent to that allotted to training. For this experiment the testing apparatus and methodology were changed substantially from those used in Experiment I. However, the training procedure was identical to that used in Experiment II.

The silhouette recognition test used vehicular silhouettes very similar to those used during training. This test was expected to reveal whether improvements realized through indoor training would transfer to a nearly identical task during driving. A test of motion detection was incorporated in the testing procedure to determine if improvements realized through training on one type of peripheral visual function, namely recognition of vehicular silhouettes, would transfer to an apparently very different peripheral function, detection of movement. If both the silhouette recognition test and motion detection test revealed substantial improvements during driving, it could reasonably be concluded that the effects of peripheral vision training are general and not specific to the function trained. If, on the other hand, improvements occurred only for the vehicular silhouette recognition test, this would suggest that the effects of training were somewhat specific.

APPARATUS

Testing

The van testing equipment and screen described previously were also used for the present experiment. However, the projector system for silhouette recognition testing was changed from that used during Experiment I and additional equipment was added for motion testing. During Experiment I, white cardboard had been used for the projection surface of the perimeter screen. It was discovered that shadows and bright reflections on the screen, originating outside the van, were noticeable to the driver. To reduce these effects, the white screen was replaced by black cardboard. With the filter material in place on the van windows, the background luminance of the black cardboard screen was $.06 \text{ cd/m}^2$. The platform for supporting the projection system, the mirror periscope, and the hood to block the subject's view of the periscope were the same ones used in the first experiment.

Eight positive transparencies of vehicular silhouettes, four for left-side projection and four for right-side projection, were mounted in a specially constructed projector which could be easily manipulated by the experimenter. The four vehicular silhouettes (automobile, bus, motorcycle, and truck), shown in the top portion of Figure 3, were used for testing. Projected on the perimeter screen, these silhouettes had a horizontal extent of 3.4° . The luminance of the silhouettes was $.79 \text{ cd/m}^2$ and, therefore, the contrast was 12.2. A timing apparatus, controlling the current to the projector bulb, limited the presentation time to 125 msec. As in the first experiment, the projector could be rotated about an imaginary vertical axis midway between the subject's eyes. A schematic representation of the projection apparatus is shown in Figure 31.

A test of peripheral motion sensitivity was included since this function appears to be of obvious importance to driving and to determine if improvements in peripheral vision

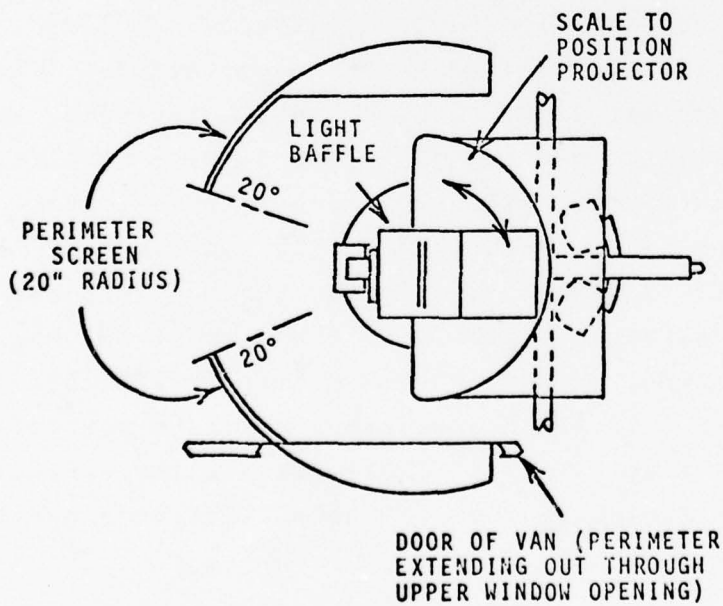
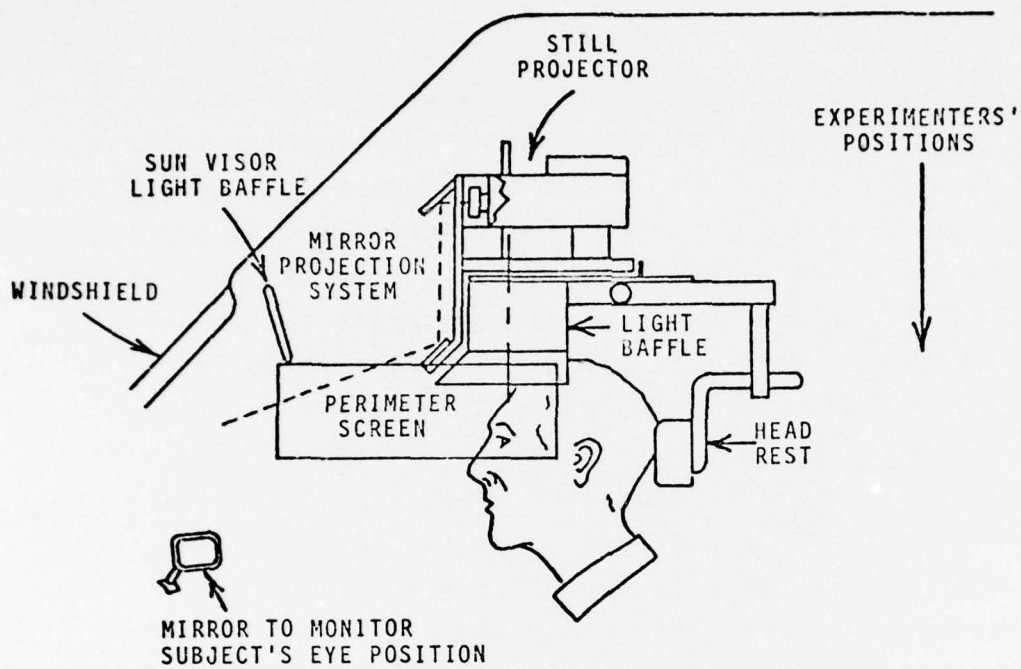

Figure 31. Testing apparatus, in side view (upper illustration) and plan view (lower illustration), shown in relation to the subject's position.

on a form recognition task would generalize to a completely different type of peripheral function.

The motion detection task was changed considerably from that used for Experiment I. Previously, diamond-shaped targets which moved in a horizontal direction or grew or diminished in size were used because this corresponded to the type of motion test used in the Mark I Integrated Vision Tester. These types of motion tests were abandoned for two reasons. First, since the Mark I Integrated Vision Tester, used during Experiment II, did not reveal any changes in performance on the peripheral tests for motion detection, its use was abandoned. Therefore, there was no reason to obtain similar type measures in the van for comparison.

Second, during Experiment I it was noticed that when the movement targets first appeared they were easily detected by the subject, and his task became one of discriminating the direction of movement. Discrimination of motion after the detection of a target seems relevant to central vision functions during driving but not to peripheral vision. For peripheral vision it is more likely that a driver detects the presence of a vehicle or another object because it moves rather than first detecting the object from other peripheral cues and then noticing its movement characteristics. An apparatus for motion testing which was more compatible with this interpretation was devised. Because of the previously discussed difficulty of controlling motion silhouettes presented by film, a mechanical technique was used which allowed the experimenter to control both the time of presentation and the rate of movement of the motion target.

To obtain a motion target which could not be seen except while moving, a camouflage technique was used. A pattern of random dots, 50% white and 50% black with each element being a square measuring 1.0mm on a side, was used for both the target and the background. This type of pattern was originally developed by Julesz (1971) to create stereograms of objects

which contain no monocular cues to the object's shape and which can be seen only by stereo separation in depth. The present application did not involve stereopsis, but simply took advantage of the fact that when a segment of the random-dot pattern is placed upon a background of the same material, it is invisible unless it moves. For mechanical reasons it was decided to use a rotating random-dot target shaped like a Maltese cross against a square background field of the same material.

Two of these targets and backgrounds were mounted, one on each half of the perimeter screen, for motion testing. These could be removed for silhouette recognition testing. The diameter of the target cross was 8.3 cm (3.25 in.) and the background material was a square measuring 10.2 cm (4.0 in.) on a side. The cross and background subtended 9.3° and 11.4° , respectively, at the subject's eye. The luminance varied with the ambient lighting conditions, but the luminance of the white area of the targets averaged $.89 \text{ cd/m}^2$. The luminance of the black portions of the targets averaged $.06 \text{ cd/m}^2$ and, therefore, the average contrast was 13.8.

For motion testing, these targets were located at either 30° or 45° to the left and right. Rotary motion was imparted to the target crosses by use of SLO-SYN motors and a chain-linked gear reduction system mounted on the rear of the perimeter screens. The direction of rotation, clockwise or counterclockwise, was under the control of the experimenter. The rate of rotation could also be controlled by the experimenter and was continuously variable from .12 to 2.4 revolutions per minute. The rates of motion are reported in terms of the angular movement of the extreme edge of the target in minutes of arc per second, measured from the subject's eye position. The duration of the motion presentations was always 500 msec.

The chain-driven gear system was virtually free of all backlash. The SLO-SYN motors had an angular step size of

1.8°. That was reduced by a 50:1 gear system. Therefore, each step of the motor caused a point on the circumference of the target to move only 10.5 seconds of arc measured at the subject's eye position. Thus, an individual step of the motor was essentially invisible and the motion, when it was apparent from continuous pulsing of the motor, appeared as smooth rotational movement. Figure 32 is a schematic representation of the motion testing apparatus.

A Bausch and Lomb Ortho-Rater was used to collect fundamental visual data on the experimental and control subjects to ensure that the two groups had comparable basic visual abilities.

Training

The training apparatus used for Experiment II was also used for Experiment III.

PROCEDURE

An outline of the testing and training schedule is shown in Table 7. For this experiment both the pre- and posttesting periods were extended to 2 hours a day for 2 days to obtain a sufficient amount of data to produce reliable measures of peripheral vision performance. Silhouette recognition training and kinetic perimetry testing took place on the 10 intervening weekdays. On the day prior to the first driving test, each experimental and control subject was familiarized with the testing apparatus and drove the van until they felt they were accustomed to it. This usually took about 15 or 20 minutes. The Ortho-Rater measures were taken on this day as well as those for a test of low contrast peripheral target detection. This test will be described later in this section.

Testing

The testing procedure in the van is summarized in Table 8. The first day of testing included a motion detection test at an angular location of 30° with the van stationary, a short rest

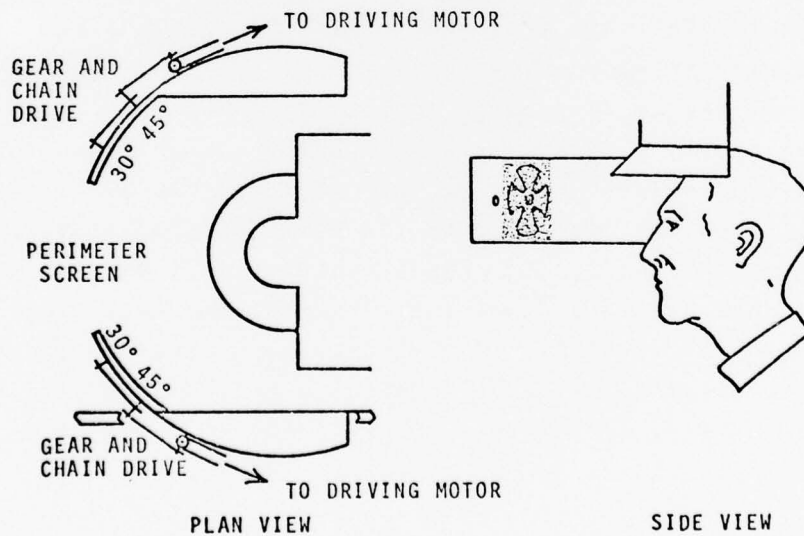
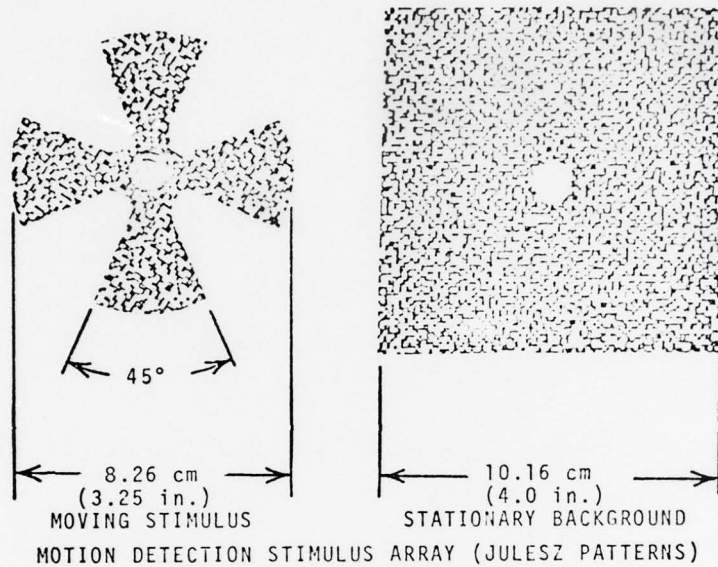

Figure 32. Schematic representation of the motion testing apparatus depicting the stimulus array (upper left and right) and plan and side views (lower left and right, respectively) of the perimeter.

TABLE 7
SUMMARY OF EXPERIMENT III TESTING AND TRAINING SCHEDULE

EXPERIMENTAL GROUP (N = 8)	CONTROL GROUP (N = 8)
PRELIMINARY TESTING AND FAMILIARIZATION	PRELIMINARY TESTING AND FAMILIARIZATION
A. Ortho-Rater testing B. Low contrast target detection tests C. Familiarization ride in van	A. Ortho-Rater testing B. Low contrast target detection tests C. Familiarization ride in van
PRETESTING	INITIAL TESTING
Days 1 and 2* A. Motion detection test with van stationary B. Motion detection test driving van on highway C. Silhouette familiarization with van stationary D. Silhouette recognition test driving van on highway (targets at 30°, 45°, and 60°)	Days 1 and 2* A. Motion detection test with van stationary B. Motion detection test driving van on highway C. Silhouette familiarization with van stationary D. Silhouette recognition test driving van on highway (targets at 30°, 45°, and 60°)
TRAINING	10-day interval
Days 1, 3, 5, 7, 9 A. Kinetic perimetry test B. Dual-silhouette recognition training** C. Kinetic perimetry test	
Days 2, 4, 6, 8, 10 A. Kinetic perimetry test B. Single-silhouette recognition training** C. Kinetic perimetry test	FINAL TESTING
POSTTESTING	Day 1 Low contrast target detection test
Day 1 Low contrast target detection test	Days 1 and 2* A. Motion detection test with van stationary B. Motion detection test driving van on highway C. Silhouette familiarization with van stationary D. Silhouette recognition test driving van on highway (targets at 30°, 45°, and 60°)
Days 1 and 2* A. Motion detection test with van stationary B. Motion detection test driving van on highway C. Silhouette familiarization with van stationary D. Silhouette recognition test driving van on highway (targets at 30°, 45°, and 60°)	

*The motion detection target was at 30° on day 1 and at 45° on day 2. In all other respects the test procedures were the same for the 2 days.

**The 5° silhouettes were used on all training days except 7 and 8 when the 2.4° silhouettes were used.

TABLE 8
SUMMARY OF TESTING SCHEDULE IN VAN

Day 1	<p>A. Motion threshold:</p> <ol style="list-style-type: none"> 1. 30°, van stationary facing mountains (north) in HFR parking lot 2. 30°, van moving northbound on U.S. 101, 50 mph (break at Gaviota) <p>B. Silhouette recognition:</p> <ol style="list-style-type: none"> 1. Park van facing mountains (north) in Gaviota parking lot 2. Silhouette familiarization, show subject the drawings of the silhouettes and then run 24 silhouette practice trials with van stationary <p>C. Silhouette test, van moving southbound on U.S. 101</p> <table style="margin-left: 40px;"> <tr> <td>32 trials at 30°</td> <td rowspan="3" style="font-size: 3em; vertical-align: middle;">}</td> <td rowspan="3" style="vertical-align: middle;">45 mph</td> </tr> <tr> <td>32 trials at 45°</td> </tr> <tr> <td>32 trials at 60°</td> </tr> </table> <p>D. HFR, break for the day</p>	32 trials at 30°	}	45 mph	32 trials at 45°	32 trials at 60°
32 trials at 30°	}	45 mph				
32 trials at 45°						
32 trials at 60°						
Day 2	<p>A. Motion threshold:</p> <ol style="list-style-type: none"> 1. 45°, van stationary facing mountains in HFR parking lot 2. 45°, van moving northbound on U.S. 101, 50 mph (break at Gaviota) <p>B. Silhouette practice trials (16) with van stationary in Gaviota parking lot</p> <p>C. Silhouette recognition, van moving southbound on U.S. 101</p> <table style="margin-left: 40px;"> <tr> <td>32 trials at 30°</td> <td rowspan="3" style="font-size: 3em; vertical-align: middle;">}</td> <td rowspan="3" style="vertical-align: middle;">45 mph</td> </tr> <tr> <td>32 trials at 45°</td> </tr> <tr> <td>32 trials at 60°</td> </tr> </table> <p>D. HFR, termination of experiment</p>	32 trials at 30°	}	45 mph	32 trials at 45°	32 trials at 60°
32 trials at 30°	}	45 mph				
32 trials at 45°						
32 trials at 60°						

period, followed by a repeat of the same test while the subject drove the van on a divided four-lane highway between Goleta and Gaviota, California. A 15-minute rest break was taken at Gaviota. The subject was then familiarized with the silhouette recognition test. He was given 24 presentations with feedback. The silhouette test was then conducted at 30°, 45° and 60° while the subject drove the van back to Goleta.

The second day of testing was very similar to the first. With the van stationary, the motion test with the stimuli at 45° was conducted. This test was repeated while the subject again drove to Gaviota. After the 15-minute break at Gaviota, the subject was given an abbreviated familiarization with the silhouette recognition test. In this case only 16 presentations were made with feedback. During the drive back to Goleta the silhouette test, the same as was given the previous day, was conducted.

After the 10 days of training, or in the case of the control subjects, after an equivalent time interval, the 2 days of testing in the van were repeated. The protocol for these last 2 days of testing was the same as for the first 2 days except the Ortho-Rater tests were not repeated.

Motion Detection Test

The motion testing procedure for both conditions (with the van stationary and while the subject was driving the van) and for both peripheral angles of testing (30° and 45°) was the same. A modified staircase method was used to determine motion detection thresholds for the left and right peripheral fields.

Use of Staircase Method

The staircase method is essentially a threshold tracking method. That is, some stimulus value is chosen for the initial presentation and, depending upon whether the subject

detects or fails to detect the target, the stimulus value is either decreased or increased for the next presentation. The size of the change in value of the parameter of interest is initially fairly large, and successive presentations should result in alternate detections and nondetections. As the procedure progresses, the experimenter reduces the size of the steps of change of the stimulus parameter, whatever it may be, and the bracketing procedure eventually narrows down to a band of values distributed about the subject's threshold. When the step size has been reduced to the minimum practical, or the minimum consistent with the variability in the subject's performance, the sequence of presentations is carried out a little longer, switching back and forth between lesser and greater parameter values over a fairly narrow range. When the data are plotted in terms of correct and incorrect detections, the resultant graph should, ideally, look like a damped oscillating function with large excursions in amplitude in the beginning, gradually narrowing to a straight line at the end. The threshold is the mean of the detected and nondetected values, i.e., the value at which 50% detection occurs. Details and extensions of this methodology are given in Cornsweet (1962).

This technique has several advantages. It adapts to the individual subject's threshold, and when wide variations in threshold between subjects are expected, it ensures that a large number of trials is not wasted in the sense that they are well above or well below a particular subject's detection threshold. The method, therefore, tends to minimize the number of trials required to establish a threshold. Also, it gives a complete time history of the subject's performance, so that variation in threshold with time can be easily seen. It has a small disadvantage in that it requires a certain amount of acumen on the part of the experimenter for determining the size of the stimulus change that should be made from trial to trial. Ideally, if the experimenter chooses the step sizes properly, half of the trials will result in detections and half in misses.

This methodology was applied to the determination of motion thresholds in the present experiment.

The experimenter used a keyed score sheet to determine whether the presentation would be on the left or the right, and whether the direction of rotation of the target would be clockwise or counterclockwise. The random order of the presentations was constrained by requiring that within a block of 16 trials each combination of side of presentation and direction of rotation should occur equally often. The speed of rotation of the target was the independent variable which the experimenter adjusted according to the requirements of the staircase.

Since the staircase functions for the left and right sides were scored independently, and the presentation alternated back and forth between them in a random manner, the subject had no way of knowing which target would revolve on any given trial, or whether the trial was likely to be detectable or nondetectable. In practice, each test involved a total of between 90 and 120 presentations. Generally, the presentation series was terminated after about 25 minutes of testing when the end of the test course was reached rather than because the threshold became completely stable. Problems associated with threshold stability will be addressed in the Discussion section.

The procedure for administration of the motion test was the same for both the stationary condition, when the van was parked, and for the moving condition, when the subject was driving. Prior to each trial, the experimenter would say, "Ready," to alert the subject to maintain fixation straight ahead for the next few seconds. Approximately 1-2 seconds later one of the two targets would rotate. If the subject detected the rotation, he would call out the side and direction of rotation. If he failed to detect the motion he indicated this. Sometimes the subjects responded and added the caveat that they had guessed. The subjects were instructed

that one of the two stimuli would actually move on each trial. But, due to the nature of threshold measurement procedures, they were also told that the motion would be small enough so as not to be detectable on approximately 50% of the trials. They were reminded of this fact if they voiced discomfort concerning the number of trials on which they saw no movement. The experimenter then recorded the response and adjusted the target speed for the next presentation. The inter-trial interval was usually about 10 seconds. The subject rapidly became accustomed to the testing routine and knew that the target motion would occur very shortly after the experimenter said, "Ready." He was therefore generally aware of missing a target. The subject was encouraged to look around after each trial during the stationary testing condition, and to check his rearview mirrors, vehicle instruments, and traffic during the on-the-road testing.

Silhouette Recognition Test

The silhouette recognition test was always performed while the van was moving. The same test was repeated on both days of testing. After a rest break at Gaviota, and before the driver pulled out onto the highway on the first day of testing, the experimenter showed large pictures of the vehicular silhouettes the subject would be expected to recognize. This was followed by a presentation of 24 silhouettes, three of each vehicle type on each side of the perimeter screen at 30°. During familiarization, the experimenter would tell the subject after each presentation whether he was correct or incorrect in his identification of a silhouette. Also, after each presentation, whether the silhouette was correctly recognized or not, the experimenter would turn on the silhouette for approximately 2 seconds as an additional form of feedback. All subjects were given this familiarization. On the second day of testing, the same familiarization procedure was repeated, but only 16 presentations were given.

Once the driver had pulled out on the highway for the return trip to Goleta, the silhouette recognition test would

begin. Thirty-two presentations, four of each vehicular silhouette on each side, were given at each of three peripheral angles (30° , 45° , and 60°) for a total of 96 presentations. The initial angle of presentation was always 30° and proceeded in turn to 45° and 60° . A keyed score sheet was used by the experimenter to determine the side and silhouette which would be presented and to record the subject's responses. The experimenter would call out, "Ready," just prior to each presentation to alert the driver to fixate down the road. The inter-trial interval was again approximately 10 seconds.

Driving and Testing

During driving, the subject was asked to maintain a constant 45-50 mph and stay in the right lane as much as possible. This turned out to be quite easy. Very few vehicles were encountered traveling less than 50 mph, and the number of vehicles the van had to pass was minimal. Because of the low density of traffic, the number of vehicles passing in the left lane were relatively few. When a large truck was about to pass the van, the safety observer would alert the experimenter and the driver. The trial would be postponed until the passing truck was well ahead of the van. This procedure was adopted because the noise, air turbulence, and abrupt changes in the ambient luminance levels in the van due to the passage of large trucks were very disturbing to the subjects. By alerting the subject to the occurrence of each trial, and also by notifying him when large trucks were passing, it was hoped to reduce the variability of the measures. If the driver was not alerted to the occurrence of the trial, much greater variability in his performance would probably have occurred and, consequently, a much larger number of trials would have been required. There were no auditory or other extraneous cues to alert the driver of the exact time or side of presentation of the motion targets or the silhouette targets.

For both the motion and silhouette tests, no feedback was given to the subject about his performance except during

the familiarization trials. Also, during all the tests the driver was required to notify the experimenter if he was distracted during a presentation. In practice this occurred very rarely. Besides monitoring traffic, the safety observer would watch the subject's eye position during testing to ensure that he was in fact fixating down the road during each presentation. All subjects were very cooperative and generally fixated properly. On the few occasions when they were not fixating, they usually notified the experimenter. One subject could not be dissuaded from constantly scanning the perimeter screen and, despite several warnings, could not fixate straight ahead. Consequently, the testing was terminated after the first day and the subject was replaced.

Low Contrast Detection Test

In addition to the tests of silhouette recognition and motion detection conducted in the van, a test of low contrast object detection, using the indoor training perimeter, was given to both the experimental and control subjects once each on the first and last days of testing. The test was essentially a kinetic perimetry test for circular discs of light. Two targets were used: a 2° diameter disc with a contrast of .07, and a 10-minute diameter disc with a contrast of 1.82. The purpose of this test was to determine if both the experimental and control groups had comparable abilities on the fundamental peripheral vision function of object detection.

A second use of this test was to determine if the silhouette recognition training given to the experimental subjects would cause any improvements in detection performance. The procedure for the test was similar to that used for the kinetic perimetry; the target was advanced from the extreme periphery at a rate of about 5° per second until the subject detected the target. Five trials were given on each side with each target. The first two trials for each target on each side were discarded as practice. The subject's detection score was computed by averaging the angle at which the

target was detected for the last three trials for each target on each side. The same procedure was used on both administrations of the test.

Kinetic Perimetry Test and Training

The procedure for kinetic perimetry testing and silhouette recognition training for the experimental subjects was exactly the same as used in Experiment II. No retention testing, however, was done on this last group of subjects.

SUBJECTS

Sixteen individuals, 57 years of age or greater, served as subjects. All were recruited through a newspaper advertisement soliciting participation in a vision and driving experiment. The subjects were assigned to the experimental or control group, depending on their willingness to participate for the length of time required for each group: 15 days for the experimental subjects and 5 days for the control subjects. Each subject possessed a valid California driver's license.

RESULTS

Ortho-Rater Low Contrast Detection

The age, sex, whether glasses were worn or not, Ortho-Rater scores, and the data from the low contrast detection tests are shown in Table 9 for the subjects of Experiment III. The overall average angle of detection for the low contrast 2° diameter disc was 33.7°. No significant differences were found between the experimental and control groups, the pre- and the posttests, or for any of the interactions. For the 10-minute diameter disc the average angle of detection for both the experimental and control groups was 28.1° on the left side and 30.7° on the right side. An ANOVA indicated that the difference in the angle of detection between the two sides was significantly different ($df = 1, 14; F = 7.7; P < .05$). There were, however, no significant differences in performance between the

TABLE 9
SCREENING DATA, ORTHO-RATER AND LOW CONTRAST PERIMETRY SCORES

		TRAINING (EXPERIMENTAL) SUBJECTS																	
		ACUITY (SNELLEN NOTATION)						PHORIA (PRISM DIOPTERS)											
AGE	SEX	RIGHT		BOTH		LEFT		VERTICAL		LATERAL		VERTICAL		LATERAL					
		FAR	NEAR	FAR	NEAR	FAR	NEAR	FAR	NEAR	FAR	NEAR	FAR	NEAR	FAR	NEAR				
1.	F	20/25	20/16	20/22	20/33	20/40	20/33	0.17	RH	+2.33	0.5	LH	-1.5	42.45	34.40	40.42	34.44		
2.	M	20/40	20/33	20/29	20/50	20/50	20/33	0.17	LH	+1.33	0.5	LH	-12.0	21.19	23.24	33.35	37.34		
3.	M	20/25	20/29	20/25	20/67	20/67	20/33	0.5	RH	+1.33	0.17	RH	-4.5	39.37	42.46	45.54	51.53		
4.	M	20/25	20/29	20/29	20/40	20/22	20/33	0.5	RH	+0.33	0.5	RH	-4.5	41.44	37.44	30.26	18.21		
5.	M	20/22	20/22	20/18	20/50	20/50	20/50	0.17	LH	+3.33	0.17	RH	-9.0	45.41	23.26	32.30	22.30		
6.	F	20/33	20/29	20/22	20/100	20/67	20/67	1.0	RH	+5.33	1.0	RH	+3.0	43.29	16.16	40.41	37.23		
7.	M	20/29	20/40	20/25	20/40	20/67	20/40	0.17	RH	+3.33	0.17	RH	-15.0	29.58	19.25	31.41	33.41		
8.	M	20/29	20/40	20/23	20/50	20/67	20/50	0.17	LH	+4.33	0.5	RH	-1.5	28.26	28.54	25.30	16.20		
$\bar{X} = 56.1$		20/29		20/25		20/50		20/40						28.32		35.35		32.34	

		CONTROL SUBJECTS																	
		ACUITY (SNELLEN NOTATION)						PHORIA (PRISM DIOPTERS)											
AGE	SEX	RIGHT		BOTH		LEFT		VERTICAL		LATERAL		VERTICAL		LATERAL					
		FAR	NEAR	FAR	NEAR	FAR	NEAR	FAR	NEAR	FAR	NEAR	FAR	NEAR	FAR	NEAR				
1.	F	20/17	20/33	20/17	20/100	20/67	20/67	0.17	RH	-1.66	0.17	LH	-3.0	44.46	33.33	40.51	36.34		
2.	F	20/25	20/16	20/20	20/33	20/29	20/25	0.17	LH	+0.33	0.17	RH	-10.5	38.35	38.42	31.33	49.52		
3.	M	20/29	20/29	20/25	20/50	20/40	20/33	0.17	LH	+6.0	0.17	LH	+6.0	51.39	19.20	32.21	16.21		
4.	M	20/22	20/20	20/22	20/22	20/50	20/22	0.17	RH	+2.33	0.17	LH	-6.0	32.34	32.39	30.31	34.30		
5.	F	20/40	20/25	20/25	20/100	20/67	20/67	0.17	RH	+4.33	0.17	RH	+6.0	32.30	24.31	17.15	23.25		
6.	F	20/33	20/33	20/29	20/50	20/100	20/67	0.17	LH	+6.33	0.17	LH	+4.5	49.31	20.24	41.56	24.28		
7.	F	20/29	20/29	20/25	20/100	20/100	20/67	0.5	RH	-0.66	0.5	LH	-3.0	39.23	24.21	26.15	20.16		
8.	M	20/18	20/22	20/16	20/50	20/33	20/33	0.17	RH	-1.66	0.17	RH	-9.0	20.20	16.15	16.15	17.16		
$\bar{X} = 53.2$		20/25		20/22		20/67		20/50						26.26		30.27		27.29	

*Rounded to the nearest whole Snellen value.

experimental and control groups, between pre- and posttesting, nor were any of the interactions significant.

Single- and Dual-Silhouette Recognition

The average performance data obtained from the experimental subjects on the single- and dual-silhouette recognition training tasks are shown in Figure 33. The individual performance data for the experimental subjects are shown in Figures 34 through 41. On the single-silhouette recognition task, the mean angle of recognition improved from 53.1° on the first day of training to 74.4° on the last day of training, an improvement of 21.2°. An ANOVA confirmed that the improvement in performance was significant ($df = 3, 21$; $F = 16.1$; $P < .001$). There was no significant difference for the side of presentation or the interaction of side of presentation and days of training. The mean angle of recognition on the dual-silhouette test was 50.0° on the first day of training and 62.5° on the last day of training, an improvement of 12.5°. An ANOVA confirmed that the improvement on this task was also significant ($df = 3, 21$; $F = 9.5$; $P < .001$).

Kinetic Perimetry

The average performance of the eight experimental subjects on the kinetic perimetry test is shown in Figure 42. The individual performance scores are shown in Figures 43 through 50. The mean angle of recognition of the small silhouettes used for kinetic perimetry was 55.8° on the first day of training and 86° on the last day of training, an improvement of 30.2°. An ANOVA revealed that significant improvement occurred over the 10 days of training ($df = 9, 63$; $F = 36.7$; $P < .001$). Significant differences also occurred between the kinetic perimetry scores made prior to each training day and at the end of each training day. The average difference was 3.6° averaged over the 10 training days ($df = 1, 7$; $F = 59.5$; $P < .001$). An interaction between the time of the kinetic perimetry test (prior to daily training vs. after daily training) and the

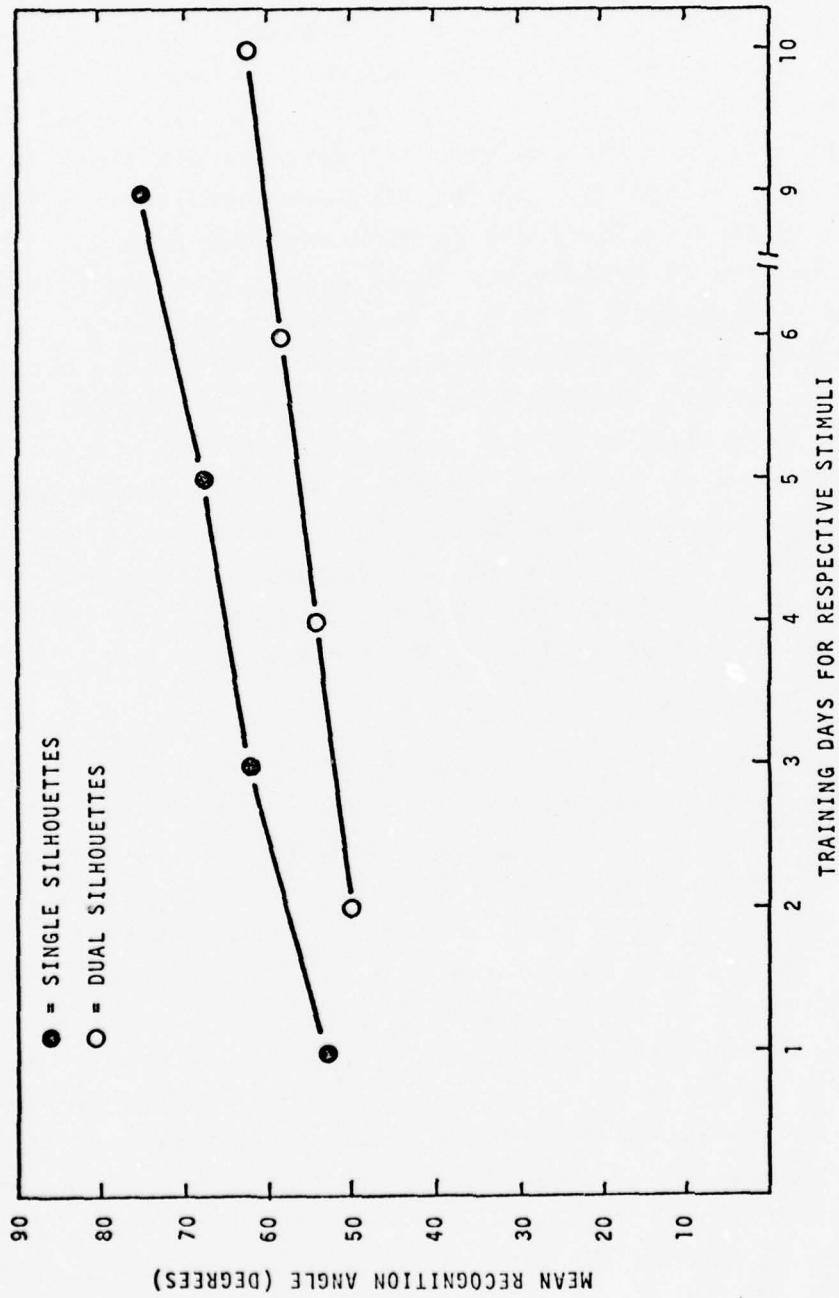
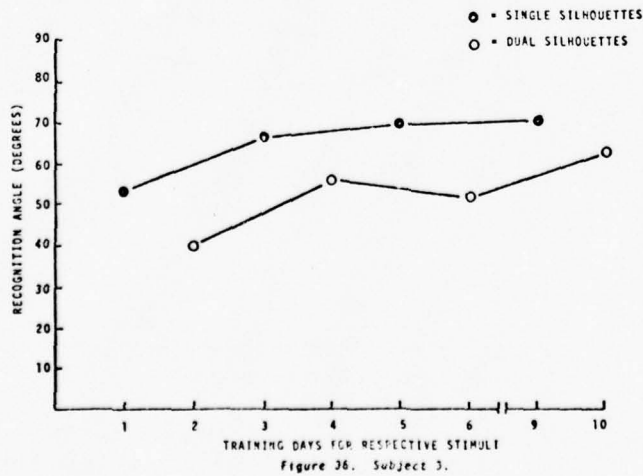
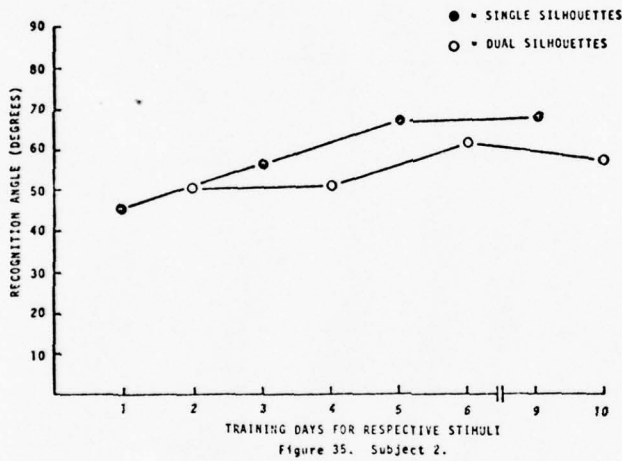
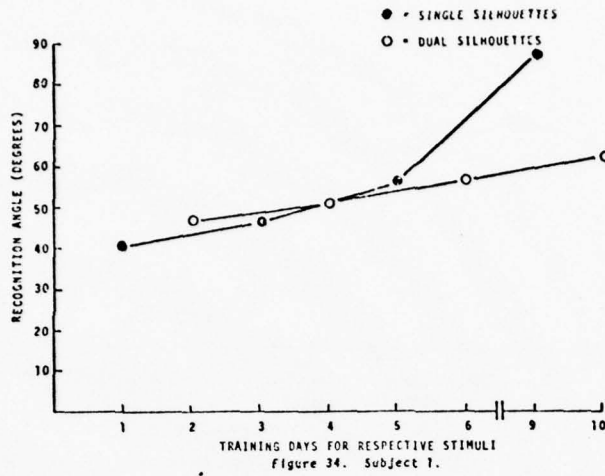

Figure 33. Mean training performance with large (5.0°) single and dual silhouettes for the experimental subjects.



Figures 34-36. Training performance with large (5.0°) single and dual silhouettes for individual experimental subjects 1, 2, and 3.

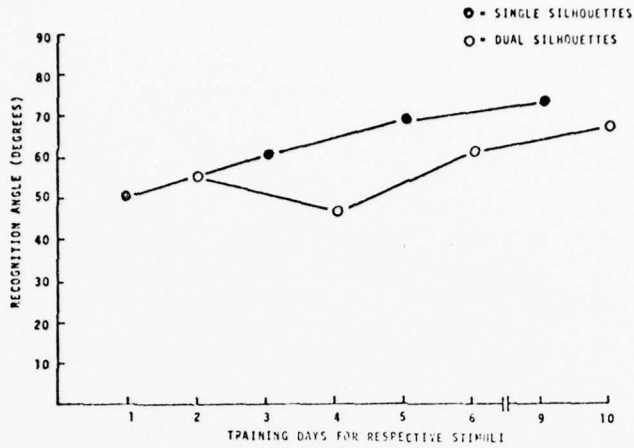

Figure 37. Subject 4.

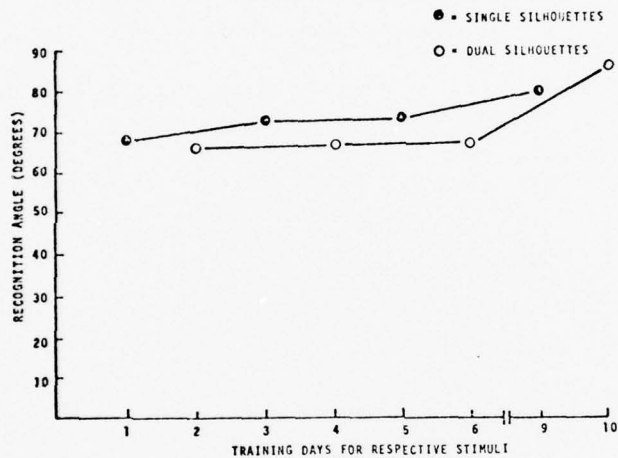

Figure 38. Subject 5.

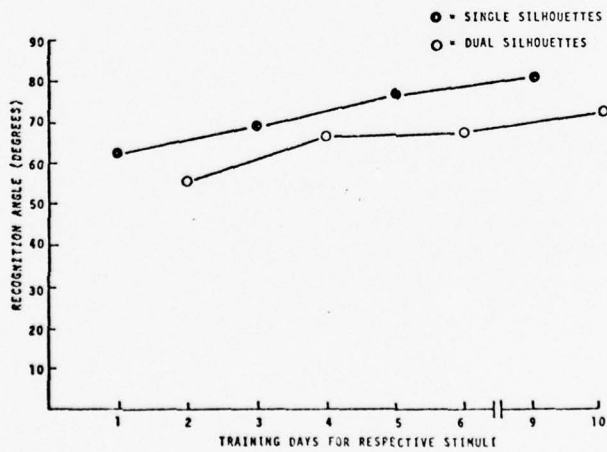
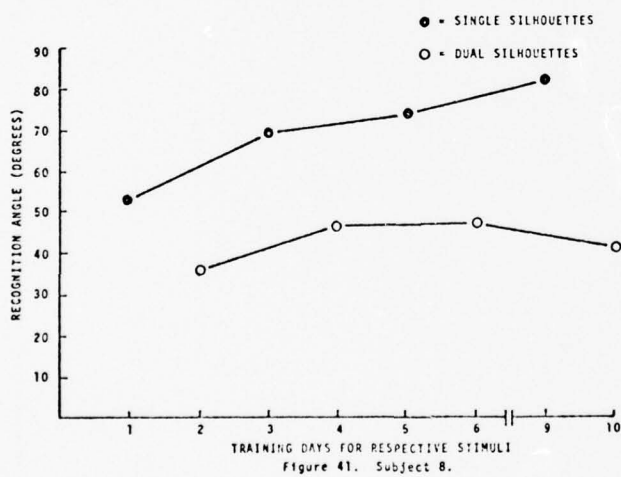
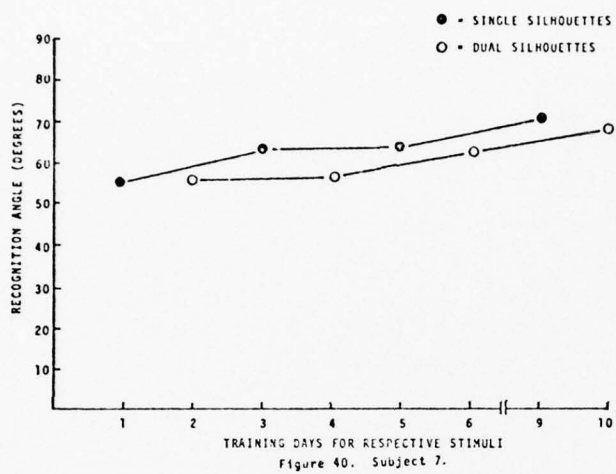

Figure 39. Subject 6.

Figures 37-39. Training performance with large (5.0°) single and dual silhouettes for individual experimental subjects 4, 5, and 6.



Figures 40 & 41. Training performance with large (5.0°) single and dual silhouettes for individual experimental subjects 7 and 8.

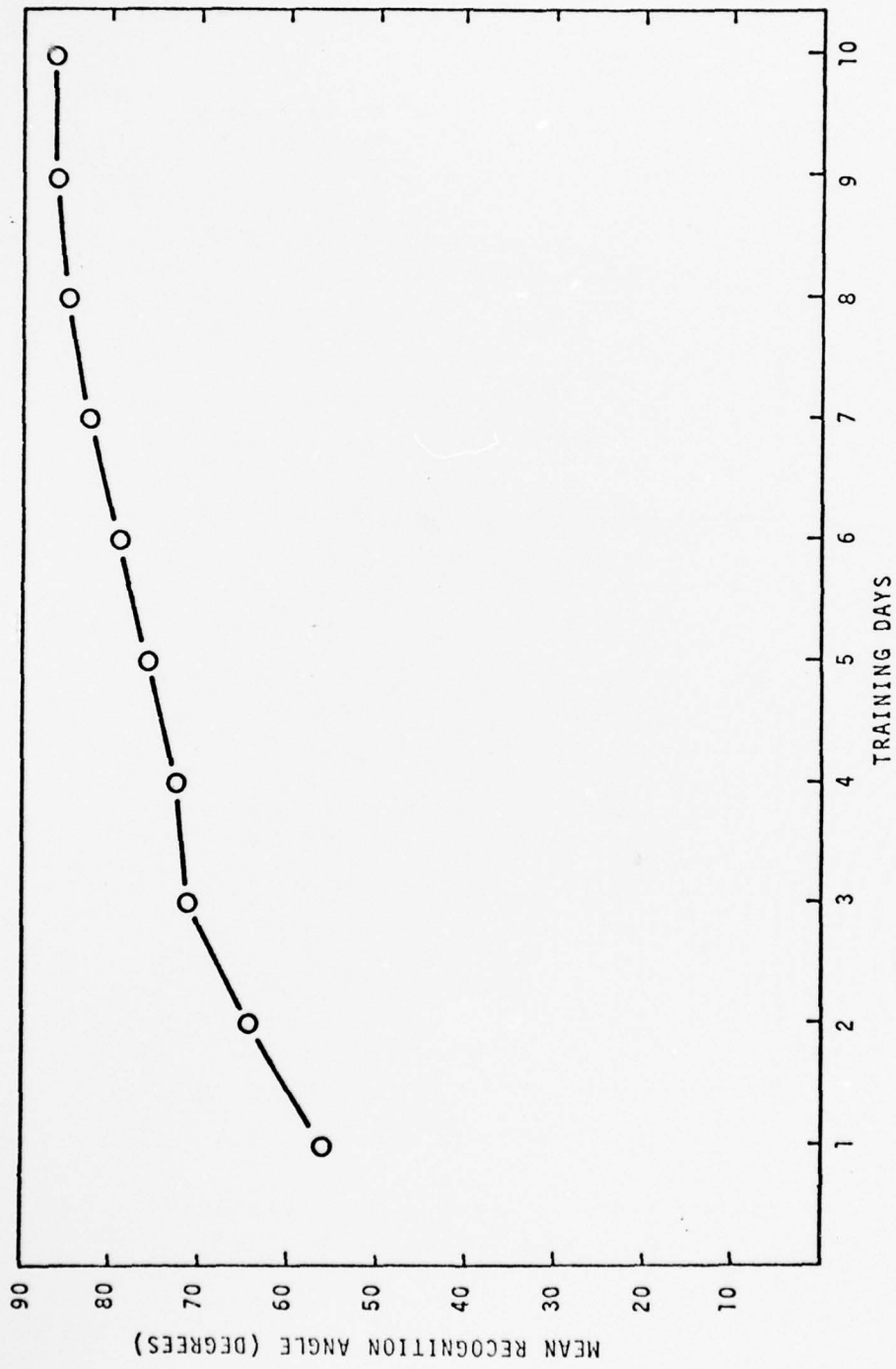

Figure 42. Kinetic perimetry performance with small (2.4°) single silhouettes for the experimental subjects.

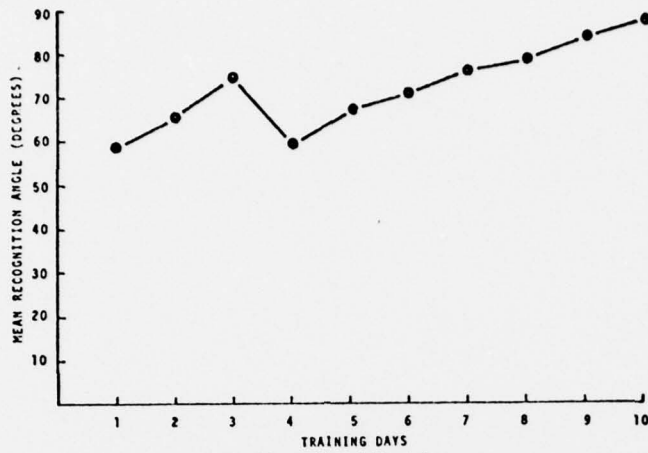

Figure 43. Subject 1.

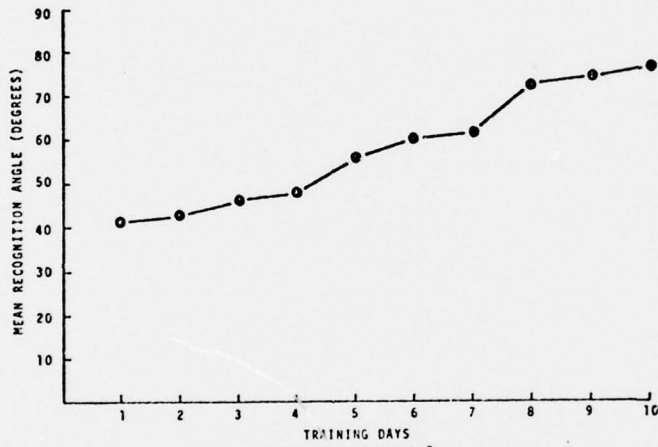

Figure 44. Subject 2.

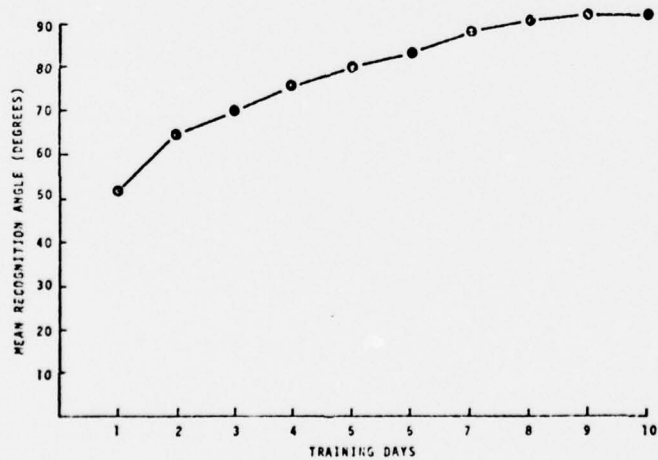

Figure 45. Subject 3.

Figures 43-45. Kinetic perimetry performance with small (2.4°) single silhouettes for individual experimental subjects 1, 2, and 3.

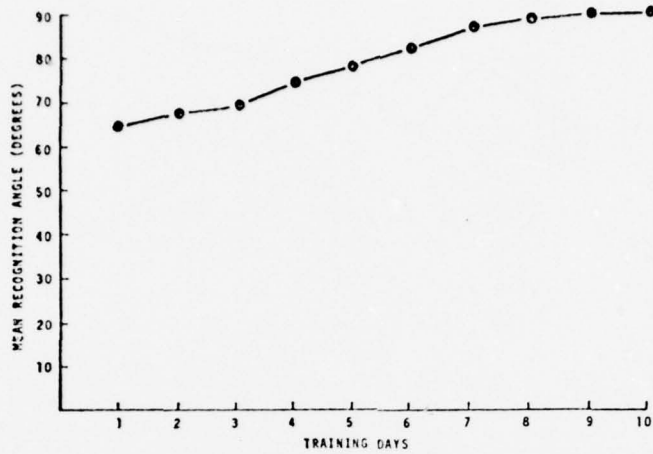

Figure 46. Subject 4.

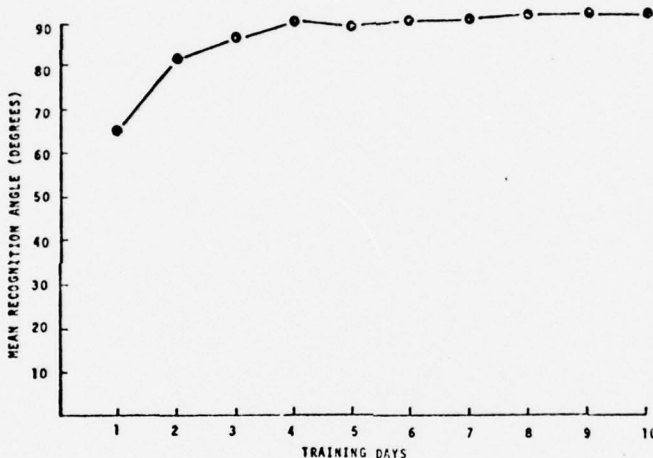

Figure 47. Subject 5.

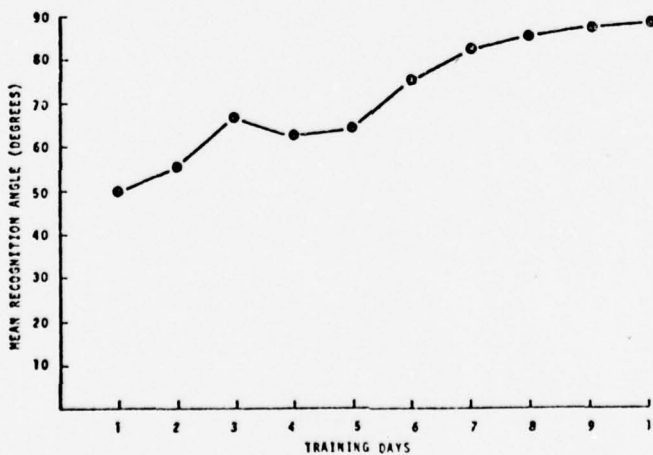

Figure 48. Subject 6.

Figures 46-48. Kinetic perimetry performance with small (2.4°) single silhouettes for individual experimental subjects 4, 5, and 6.

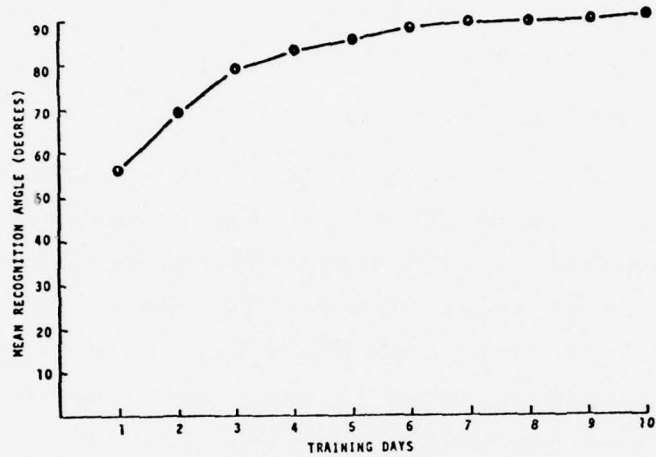

Figure 49. Subject 7.

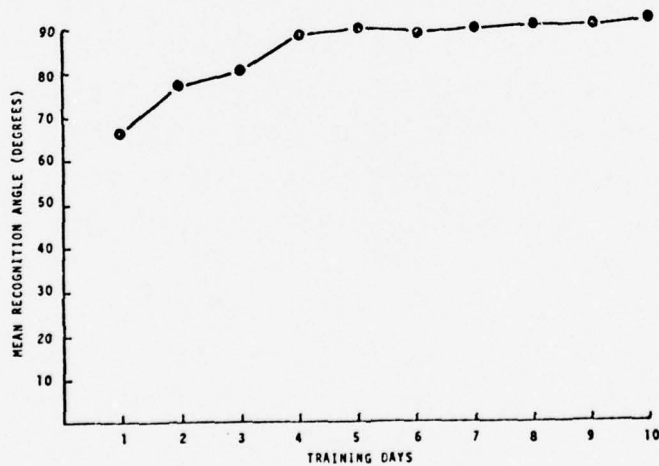

Figure 50. Subject 8.

Figures 49 & 50. Kinetic perimetry performance with small (2.4°) single silhouettes for individual experimental subjects 7 and 8.

days of training also occurred. The difference between the perimetry scores prior to daily training and after daily training tended to be larger on the early days of training and much smaller on the last few days. The same ANOVA indicated that the interaction of time of testing, beginning or end of training day, and day of testing was also significant ($df = 9, 63; F = 2.6; P < .05$).

Silhouette Recognition During Driving

The mean percent correct recognition scores for both the experimental and control groups for the silhouette recognition tests conducted while driving the van are shown in Table 10 and in Figure 51. The percent correct recognition scores have been averaged over the 2 days of pretesting and 2 days of posttesting. Table 11 shows the average change in percent correct recognition between each successive day of silhouette testing. The percent correct recognition scores in Tables 10 and 11 and Figure 51 are not corrected for chance. An ANOVA revealed that there were significant differences between the performance scores for the experimental and the control groups ($df = 1, 14; F = 4.8; P < .05$), the angles of presentation ($df = 2, 28; F = 119.2; P < .001$), and the pre- and post-testing periods ($df = 1, 14; F = 39.5; P < .001$). No significant differences in performance occurred between the first and second days of pretesting or between the first and second days of posttesting. Also, the interaction of groups (experimental and control subjects) and times of testing (initial and final) was not significant. This means that the experimental subjects did not show any more improvement in silhouette recognition than did the control subjects. Additionally, none of the remaining interactions were significant.

A second ANOVA was performed on the same data with the difference being that the pre- and posttesting periods and the days of testing within the pre- and posttesting periods were not considered as separate factors but, rather, the 4 days of testing were regarded as a single factor. This second

TABLE 10
 MEAN % CORRECT RECOGNITION PERFORMANCE ON VAN
 SILHOUETTE TESTS FOR INITIAL AND FINAL TESTING
 FOR EXPERIMENTAL AND CONTROL SUBJECTS

EXPERIMENTAL SUBJECTS

PRETESTING		
30°	45°	60°
60.8	51.6	28.3
POSTTESTING		
80.6	63.2	45.1

CONTROL SUBJECTS

INITIAL TESTING		
30°	45°	60°
74.3	61.1	40.4
FINAL TESTING		
86.2	70.7	49.1

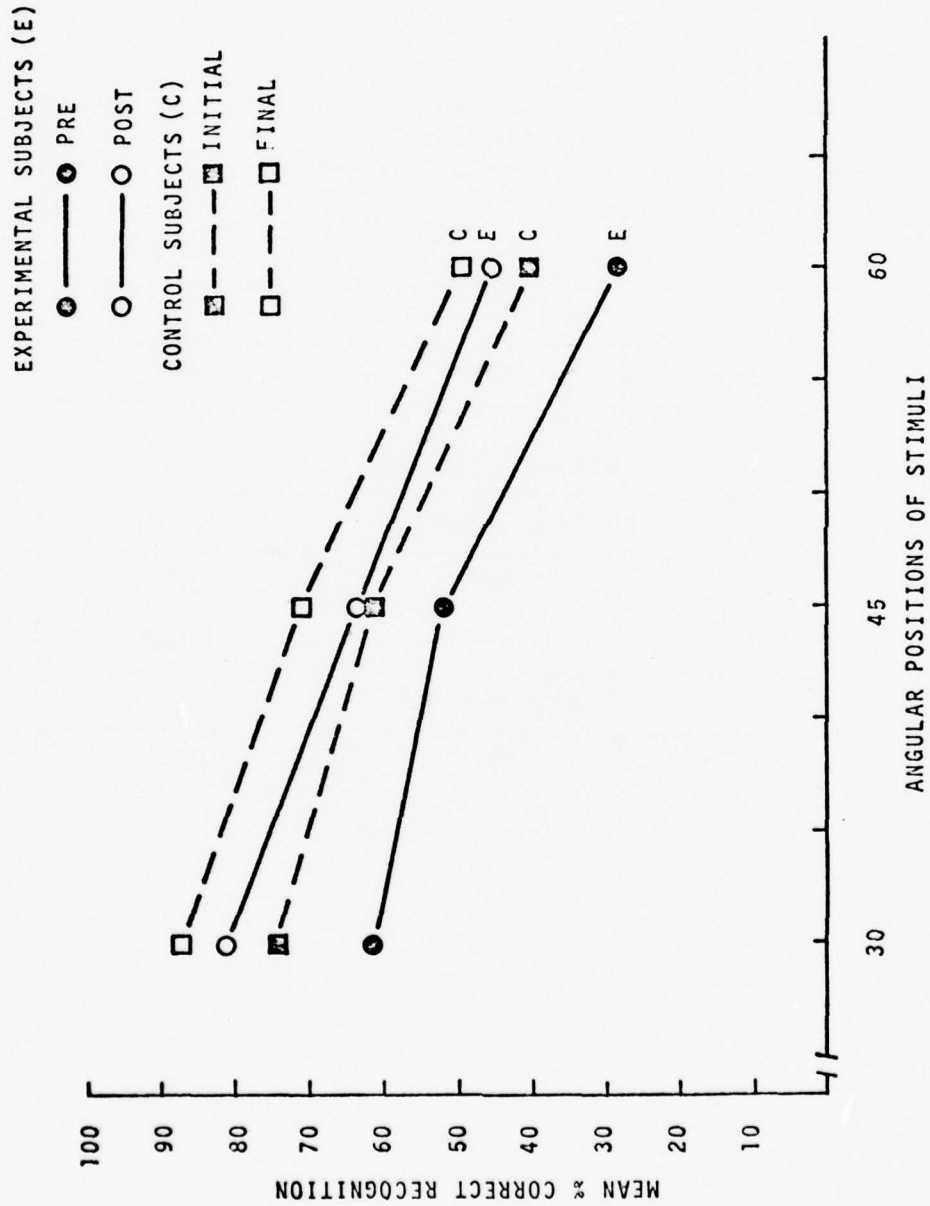

Figure 51. Silhouette recognition test performance for initial and final testing for experimental and control subjects.

TABLE 11
 MEAN % CORRECT RECOGNITION ON THE VAN SILHOUETTE
 TESTS FOR THE 4 DAYS OF TESTING

EXPERIMENTAL SUBJECTS

	<u>PRETRAINING</u>		<u>POSTTRAINING</u>	
	<u>DAY 1</u>	<u>DAY 2</u>	<u>DAY 1</u>	<u>DAY 2</u>
30°	59.4	62.2	81.6	79.5
45°	48.4	54.9	61.8	64.8
60°	26.9	29.8	40.0	50.1

CONTROL SUBJECTS

	<u>INITIAL</u>		<u>FINAL</u>	
	<u>DAY 1</u>	<u>DAY 2</u>	<u>DAY 1</u>	<u>DAY 2</u>
30°	73.4	75.2	84.9	87.6
45°	57.1	65.0	70.2	71.1
60°	38.4	42.5	51.8	46.5

ANOVA was performed to allow statistical comparisons among the performance scores for the 4 days of testing. As expected, the differences among days of testing was significant ($df = 3, 42$; $F = 19.5$; $P < .001$). Duncan's New Multiple Range Test (Edwards, 1968) was conducted to determine which day's performance differed significantly from the others. This test revealed that the significant change in performance occurred between the second and third days of testing, i.e., between the second day of pretesting and the first day of posttesting. The difference was significant at the .05 level of confidence.

Motion Detection During Driving

The motion detection threshold data obtained at 30° and 45° eccentricity for the experimental and control subjects are shown in Table 12 and presented graphically in Figures 52 and 53. The data for each individual are shown in Appendix B. An ANOVA was performed on the motion detection data and the results of this analysis are shown in Table 13.

It is important to understand how the measurements used in the ANOVA were extracted from the raw data. In accord with the staircase method, during testing the experimenter varied the rate of stimulus motion from trial to trial to obtain a minimum range of values around the subject's apparent threshold. Ideally, the range should become very narrow and approximately half of the presentations should be detected and half missed by the subject. Normally, only the last 10% or 20% of the presentations would be used to compute a threshold. It became apparent, however, after all the data were collected and graphed that, in most cases, there were large cyclic variations in the subjects' detection performance. Consequently, the choice of a cut-off point establishing individual thresholds was not obvious. To minimize variability in the data, thought to be due mainly to the subjects' process of adapting to vision testing while driving, it was decided, somewhat arbitrarily, to consider only the data obtained after the initial 32 presentations (16 on either side of the

TABLE 12
 MEAN VAN MOTION TESTING PERFORMANCE FOR
 EXPERIMENTAL AND CONTROL SUBJECTS WITH
 VAN STATIONARY AND MOVING

EXPERIMENTAL SUBJECTS

<u>VAN STATIONARY</u>			
<u>30°</u>		<u>45°</u>	
<u>PRE</u>	<u>POST</u>	<u>PRE</u>	<u>POST</u>
87.7	70.8	101.5	94.2
<u>VAN MOVING</u>			
<u>30°</u>		<u>45°</u>	
<u>PRE</u>	<u>POST</u>	<u>PRE</u>	<u>POST</u>
131.6	117.5	137.4	135.1

CONTROL SUBJECTS

<u>VAN STATIONARY</u>			
<u>30°</u>		<u>45°</u>	
<u>PRE</u>	<u>POST</u>	<u>PRE</u>	<u>POST</u>
70.4	69.9	85.1	82.1
<u>VAN MOVING</u>			
<u>30°</u>		<u>45°</u>	
<u>PRE</u>	<u>POST</u>	<u>PRE</u>	<u>POST</u>
118.9	104.6	126.8	117.2

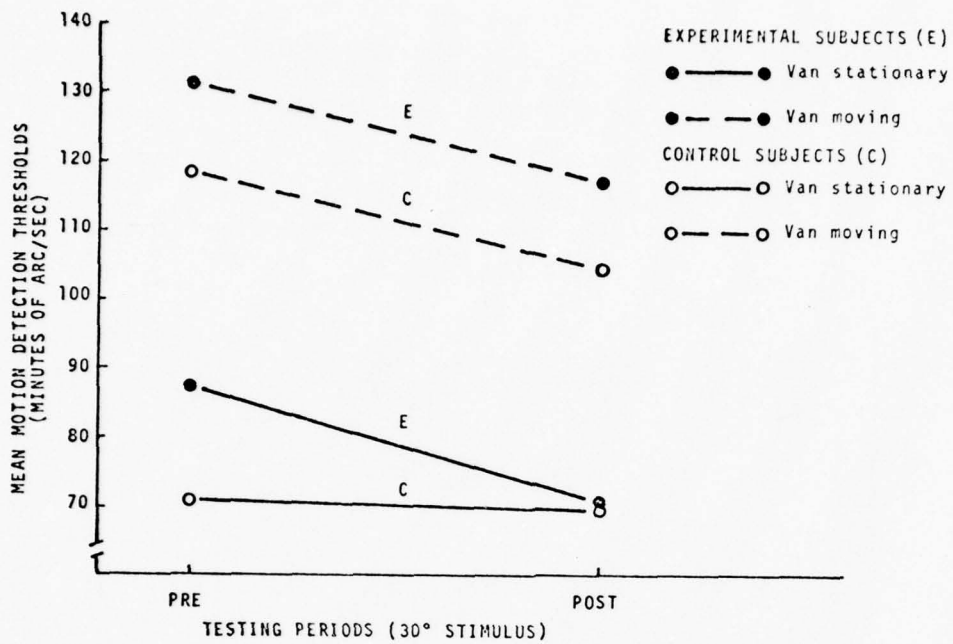

Figure 52. Motion detection performance (30° stimulus) of experimental and control subjects during driving.

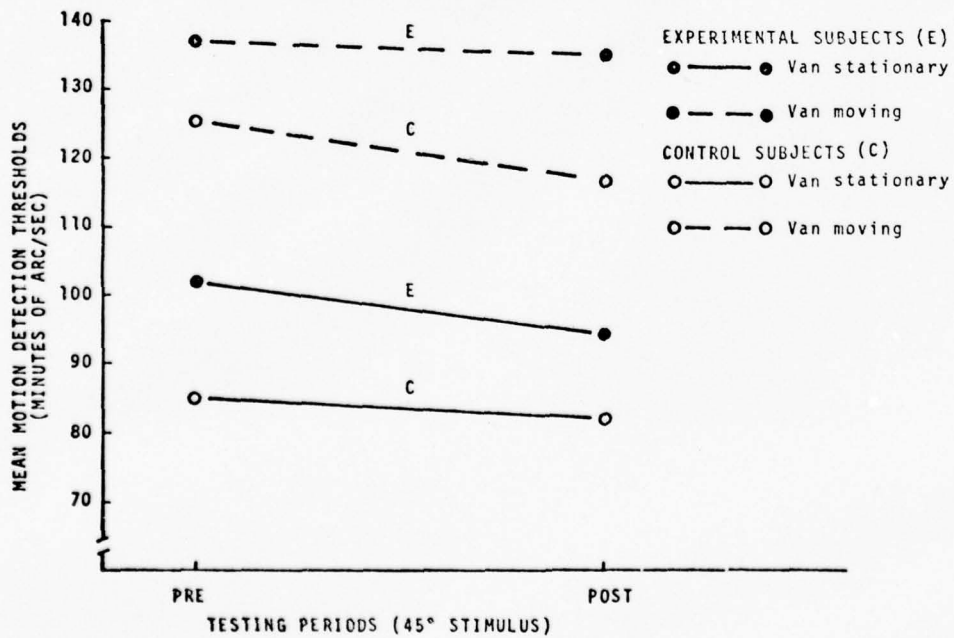

Figure 53. Motion detection performance (45° stimulus) of experimental and control subjects during driving.

TABLE 13
 ABBREVIATED SUMMARY TABLE OF ANALYSIS OF VARIANCE
 FOR MOTION DETECTION TEST DATA
 (Only factors which exceeded .05 level
 of significance are shown)

SOURCE	MEAN SQUARES	df	F	P
<u>Eyes</u>				
Right vs. Left	4,756.9	1	8.92	<.01
Eye x Group* Interaction	3,619.5	1	6.79	<.05
Error Term	533.1	14		
<u>Time of Testing (Time)</u>				
Pre- vs. Posttesting	4,624.3	1	7.96	<.05
Error Term	580.8	14		
<u>Angle of Presentation</u>				
30° vs. 45°	11,658.9	1	18.40	<.001
Error Term	633.6	14		
Eye x Time x Angle Interaction	839.2	1	6.00	<.01
Error Term	139.8	14		
<u>Driving Condition (D.C.)</u>				
Stationary vs. Moving	107,175.6	1	98.37	<.001
Error Term	1,089.5	14		
Eye x D.C. Interaction	2,235.2	1	4.73	<.05
Error Term	472.6	14		
Time x D.C. x Group Interaction	789.8	1	4.72	<.05
Error Term	167.5	14		
Eye x Angle x D.C. Interaction	1,038.4	1	8.45	<.05
Error Term	122.8	14		

*Group = Experimental and Control Subjects

perimeter) for threshold computations. Momentary threshold points were obtained by calculating the midpoint of the rate of motion between successive detected and missed presentations. For example, if the subject failed to detect a presentation at a motion rate of 100 minutes of arc per second but detected a presentation moving at 120 minutes of arc per second, the momentary threshold value would be assumed to be 110 minutes of arc per second. Every time a transition in response occurred, another momentary threshold point was calculated. Since the absolute number of trials varied from test to test and each subject showed different patterns of successive detections and misses, the number of data points obtained on each of the testing sessions varied. A single mean value of these momentary thresholds was calculated for each side of presentation (left or right), angle of presentation (30° or 45°), time of testing (pre or post), van condition (stationary or moving), and subject. These mean values became the data subjected to the ANOVA. The means and standard deviations that are associated with significant F ratios of this ANOVA are shown in Table 14.

As can be seen in Table 13, several main factors and interactions were significant. Most notably, significant differences occurred between side of presentation, pretest versus posttest, angle of presentation, and condition (whether the van was stationary or moving). It should also be noted that no significant difference was found between the overall performance of the experimental and control groups. Also, lack of a significant time of testing by group interaction indicated that there was no *differential* change in motion detection performance between the experimental and control groups from initial to final testing.

Influence of Weather on Driving Test Results

A general factor which may have influenced the results of both the silhouette recognition test and the motion

TABLE 14
 MEANS AND STANDARD DEVIATIONS ASSOCIATED WITH SIGNIFICANT F VALUES FOR MOTION TEST DATA

MAIN EFFECTS		Left		Right	
Eyes	\bar{X}	98.9	107.5		
	S.D.	35.6	33.3		
Time of Testing	\bar{X}	107.4	98.9	Pre	Post
	S.D.	35.4	37.8		
Angle	\bar{X}	30°	45°		
	S.D.	96.4	109.9		
Van Condition	\bar{X}	37.3	35.1	Static	Moving
	S.D.	82.7	123.6		
	S.D.	35.0	25.4		
2-WAY INTERACTIONS					
Eye x Group		Experimental		Control	
	\bar{X}	Left	Right	Left	Right
	S.D.	108.9	110.0	88.8	104.9
Eye x Van Condition		Static		Moving	
	\bar{X}	Left	Right	Left	Right
	S.D.	75.4	90.0	122.3	125.0
	S.D.	36.3	32.3	26.9	23.9
3-WAY INTERACTIONS					
Eye x Time of Testing x Angle		Pre		Post	
	\bar{X}	30°		45°	
	S.D.	Left	Right	Left	Right
	S.D.	99.2	105.1	106.4	119.1
Time of Testing x Van Condition x Group		Experimental		Control	
	\bar{X}	Left	Right	Left	Right
	S.D.	41.0	32.9	36.4	28.4
Eye x Angle x Van Condition		Static		Moving	
	\bar{X}	Left	Right	Left	Right
	S.D.	94.6	134.5	82.5	126.3
	S.D.	33.4	21.4	34.8	23.2
	\bar{X}	30°		45°	
	S.D.	Left	Right	Left	Right
	S.D.	69.3	80.1	81.6	99.9
	S.D.	36.7	29.6	35.4	32.3
	\bar{X}	Left	Right	Left	Right
	S.D.	114.7	121.6	129.9	128.4
	S.D.	29.7	23.8	21.7	24.0

detection test was the prevailing weather conditions during the time of testing. Because of the prolonged period of time involved in both training and testing and the fact that a number of subjects from both the experimental and control groups were being run concurrently, it was difficult to adjust the schedule to allow each subject to be tested under identical weather conditions. No subject was ever tested during rain or drizzle and the hours of testing always occurred between 9 a.m. and 4 p.m. to minimize the effects of sun angle. Also, the same type of test, either silhouette recognition or motion detection, always occurred during the same direction of travel on the highway. That is, the motion tests were always conducted while driving northwest and the silhouette recognition tests were always conducted while driving southeast. An uncontrolled variable that may have affected the results, however, was the extent of cloud cover which varied from none to complete overcast. Table 15 shows the approximate cloud conditions that existed for each day of testing for each subject. Examination of the individual subject's data did not reveal any obvious correlation between weather condition and performance on the test. The general effect of weather was to change the overall luminance level inside and outside the van. Occasional sources of glare, reflections entering the van, and sharp shadowing of all objects were evident on sunny days and, of course, absent on overcast days. To what extent this may have influenced the testing results is unknown.

DISCUSSION

Training Tasks

The eight experimental subjects who received training on the recognition of single and dual silhouettes showed the same pattern of improvement as the subjects in the previous experiment. Starting the training course with single-silhouette presentations rather than dual-silhouette presentations apparently made no important difference in the

TABLE 15
 WEATHER CONDITIONS DURING VAN
 TESTING OF MOTION DETECTION

EXPERIMENTAL SUBJECTS			
[Pretesting Weather/Posttesting Weather]			
[Sun/Sun]	[Overcast/Sun]	[Overcast/Overcast]	[Sun/Overcast]
(2) 30°s	(1) 45°sm	(3) 30°sm	(1) 30°sm
(8) 30°s	(2) 30°m	(4) 30°sm	(2) 45°s
(8) 45°sm	(2) 45°m	(4) 45°sm	(3) 45°sm
	(8) 30°m	(5) 45°sm	(5) 30°sm
		(7) 45°m	(6) 30°sm
			(6) 45°sm
			(7) 30°sm
			(7) 45°s
CONTROL SUBJECTS			
[Pretesting Weather/Posttesting Weather]			
[Sun/Sun]	[Overcast/Sun]	[Overcast/Overcast]	[Sun/Overcast]
(1) 45°sm	(1) 30°sm		(2) 30°sm
(4) 30°s	(3) 30°sm		(2) 45°sm
(4) 45°sm	(3) 45°sm		(8) 45°m
(5) 30°s	(4) 30°m		
(8) 30°sm	(5) 30°m		
(8) 45°s	(5) 45°sm		
	(6) 30°sm		
	(6) 45°sm		
	(7) 30°sm		
	(7) 45°sm		

Subject identification numbers in parentheses
 s = Van stationary
 m = Van moving

results. The pattern of improvement on the kinetic perimetry test is also similar to that found in Experiment II. Within the context of the training task there is no doubt that substantial improvement occurred as a result of the training. It is not surprising that on the single-silhouette recognition task there were no differences in average performance between the presentations on the left side and the right side. Occasionally, however, studies of peripheral performance show differences in performance for the two eyes or the two sides of the field (Abernethy & Leibowitz, 1971).

Low Contrast Disc Detection

Before and after training, or an equivalent interval in the case of the control group, all subjects were tested on their ability to detect low contrast circular targets, 2° and 10 minutes in diameter projected on the training perimeter screen. As previously noted, the only significant finding was a 2.6° difference between the left and right sides for the 10-minute target. This small difference appears to be of little consequence. There is no evidence that training on silhouette recognition affected the subjects' ability to detect these low contrast targets. Also there is no evidence that there was any improvement due to practice, such as occurred in the driving tests. Failure to find changes cannot be construed as evidence that training or practice had no effect. The possibility exists, however, that due to both the absence of loading from any other task requirements and the very fundamental nature of the test, i.e., detection of light, low contrast object detection with peripheral vision may be impervious to training or practice effects. In the absence of definitive data on this point, further speculation seems unwarranted.

Silhouette Recognition During Driving

The analysis of the results of the silhouette task conducted during driving indicates that significant and substantial improvements in performance occurred between the initial

and final days of testing for both the experimental and control subjects. This is an important finding, irrespective of the fact that there was no significant differential improvement between the two groups, i.e., the improvement could not be attributed to the indoor training. When averaged over angles of presentation and days of testing, the aggregate improvement of the experimental and control subjects amounted to 13.1%. This finding confirmed that it is in fact possible to improve drivers' use of peripheral vision. The important aspects of the peripheral vision function for driving have never been identified. It seems likely, however, if these functions are defined in subsequent work that the peripheral vision of drivers who are discovered to be deficient in these functions can be improved. It may require practice or training during actual driving but nonetheless, in one way or another, improvements can be realized.

An unexpected finding was that the control subjects improved nearly as much as the experimental subjects who received special training on silhouette recognition. The significant difference in overall performance between the experimental and control groups is only due to the fact that both initial and final performances of the control group were superior to that of the experimental group. This can be seen in the data shown in Figure 51. On the pretest the performance of the control subjects was about 10% better than that of the experimental subjects. On the posttest a smaller but consistent difference in performance favoring the control subjects is apparent. It is difficult to account for this superiority of performance since both groups were comparable in their ages, visual screening scores, and scores on the low contrast detection task. Also, both groups were drawn from the general population through newspaper solicitation and the only apparent difference between them was their willingness to participate as either an experimental or control subject.

Table 11 shows the net improvement in silhouette recognition performance between each day of testing. The major improvement in performance occurred between the last day of pretesting and the first day of posttesting. For the experimental subjects who received training during the intervening 10 days, this is where the improvement would be expected to occur. The fact that most of the improvement by the control subjects also occurred over the same interval was not expected. Apparently practice on the test itself was sufficient to cause improvements in peripheral recognition of silhouettes. As noted in the literature review, it has been established previously that simply being required to perform peripheral tasks can result in improvements of performance. All the subjects received considerable exposure to this task during the 4 days of testing. However, it would seem reasonable to expect that more improvement would occur between the first and second days of testing than between the second and third days of testing. The results are suggestive of a phenomenon similar to reminiscence. This occurs when performance on a task, after an interval of rest, resumes at a higher level than the final level obtained prior to the rest interval. William James has said, in reference to this phenomenon, that we learn to ski in the summer and swim in the winter. Or, in other words, performance improves during intervals between practice on a task. Whatever the reason, the control subjects improved on the silhouette recognition test approximately to the same degree as the experimental subjects who received additional practice and feedback on a similar task during indoor training.

Motion Detection During Driving

For the motion detection tests the results were similar. Significant improvements occurred between pre- and posttesting. There were, in this case, no differences between the performance improvements of the experimental and control subjects. Also, the amounts of improvement, while statistically significant, were not substantial. The average difference between pre- and posttest performance amounted to only about 12 minutes

of arc per second for the 30° motion test and about 5 minutes of arc per second for the 45° motion test, averaged across the stationary and moving conditions and the experimental and control subject groups. This does not seem to be an impressive amount of improvement nor one of any practical consequence. Since no significant differences in improvement developed between the experimental and control groups, it is likely that the improvements noted were due to practice effects associated with testing or other factors not related to the special training program.

Individual Motion Detection Data

During the development of the motion tests, it was expected that using the staircase method would result in a fairly stable threshold determination for each subject. Inspection of the individual motion detection data plotted in the figures in Appendix B reveal several interesting effects which contradict this expectation. First, it is obvious that the ability of the subjects to detect the motion targets varied considerably over time. That is, there were very few instances where the staircase curves smoothly converged to a narrow and stable range of rates of motion. Most of the individual data curves are characterized by large excursions in performance which change relatively slowly with time. It might be conjectured that these variations were due to extraneous environmental factors such as fluctuations in the traffic density patterns on the highway, changes in the background terrain or variability in the attentional demands of driving. This seems unlikely, however, since the same type of performance variation occurred when motion detection was tested in the stationary condition with the van parked. It is more likely that the variation in performance on the motion test is due to inherent variability of peripheral vision rather than to extraneous factors.

Two studies by Ronchi (1970) and Ronchi and Viliiani (1973) have shown that performance on a vigilance task

requiring detection of small lights regularly blinking in the peripheral field undergoes regular periodic variation of a substantial magnitude. It is possible, therefore, that the present motion detection data reflect a similar type of variation which is an inherent characteristic of peripheral vision performance and not an artifact of the methodology or testing conditions. It is possible that pre/posttesting performance changes and any differential improvement between the experimental group and the control group may be obscured by this variability of the motion detection data.

The individual graphs of the motion detection data have another interesting feature. It can be seen that performance on the left and right sides was rarely the same. Generally performance on either the left or right side was superior to the other, but it is not always the same side for all subjects. It can be seen by perusing the individual graphs that in some instances the performance on both sides tended to vary together, while in other instances there appeared to be symmetrically opposite changes in performance. That is, increased performance on one side was accompanied by a decrease in performance of similar magnitude on the other side. This characteristic of the data suggests that over time the attention of the subject might be biased to one side or the other and that this biasing undergoes oscillatory variations. It is unlikely that these differences are the result of failure to maintain fixation since the safety observer monitored the subject's eye position fairly closely. Most studies of peripheral vision have ignored variation in performance with time and have concentrated on obtaining average measures of performance over an entire session of testing. Further investigation of periodic variations of peripheral performance with time might be worthwhile for both practical and theoretical reasons.

It is likely that any future battery of driver visual screening tests will include some measure of peripheral

vision. If it turns out that variation of performance is an inherent characteristic of peripheral vision, it could be extremely difficult to obtain reliable measures of peripheral performance in an abbreviated test such as is typically envisioned for screening purposes.

More knowledge concerning the variation in peripheral vision performance also would be of interest for theoretical reasons. As discussed in the literature review, peripheral vision appears extremely sensitive to task loading and environmental variables. Often these variations are attributed to some attentional mechanism. It would be desirable to know whether such variation is attributable entirely to attention, however defined, and therefore possibly demonstrable in other sensory modalities, or whether extreme variation in performance is an idiosyncratic characteristic of peripheral vision.

Motion Detection Testing Methodology

Methodologically the motion test used in the present experiment seems to be a good one. Because of the camouflage effect produced by using a target and background of a random-dot pattern, the target is invisible until it moves. This obviates the possibility that the motion of the target, though unnoticed by the subjects, could be inferred from an apparent displacement after the target had moved. Second, it avoids the possibility that the detection of the target motion was keyed by the target onset which occurs for projected stimuli rather than by target motion characteristics *per se*. Third, because of the small size of the random-dot pattern, the target and background appear to be a uniform mottled grey. Consequently the target is relatively immune to Troxler fading, a well-known phenomenon where objects visible in the peripheral field tend to appear and disappear when the eyes maintain a fixed position for several seconds or longer.

While this test was being developed, several circular targets of alternating black and white stripes were tried.

Marked Troxler fading effects were evident with this type of target. Also, during preliminary testing of these striped targets, subjects would quite often report spontaneous movement. That is, although the discs were stationary between trials, the subject would report a movement of the left or right target. Because of the frequency of occurrence of this apparent movement there was some serious doubt whether peripheral motion targets which were always visible to the subject could be used for testing. When the random-dot target and background were tried, however, neither Troxler fading nor frequent apparent movement occurred. Based on these results and the desirability of using a motion target which was invisible until it moved led to the adoption of the random-dot motion test used in the present experiment.

Rotating targets have been used in at least one previous study of peripheral movement detection (McColgin, 1960). Although linearly moving targets have been more usual stimuli, there does not appear to be any strong theoretical reason for using one type of movement instead of the other.

Rotary rather than linear motion was used in this experiment for several practical reasons. First, using a circular target allowed complete freedom of the direction of movement on any trial. Use of linear movement would require compensatory offsetting movements of equal extent to avoid cumulative displacement of the targets in the periphery which would interfere with the procedure. Obviously this would complicate the experimenter's task. Second, the size of the rotary target could be changed easily to make detection easier or more difficult. As it turned out this was not necessary. Third, the mechanical implementation of the rotary motion target was much simpler than the implementation of a linear motion target and problems of backlash were avoided.

During the course of motion testing it became apparent that when the motion of the target was detected, it was

extremely rare for a subject to misinterpret the direction of rotation. That is, if the motion of the target was detected the direction of rotation was almost always correct. During the entire course of testing for all subjects there were only about 15 misinterpretations of the direction of rotation. In those instances where a direction of rotation was incorrect, the trial was scored as a miss. The number of incorrect reports of the direction of motion was probably minimized by the instructions to the subject not to guess if he did not detect motion on either the left or the right. It was apparent that the subjects complied with these instructions since there were no reports of movement on the wrong side.

Transfer of Training

The original objective of this work was to determine whether peripheral vision of motor vehicle drivers could be improved through training. These results confirm that peripheral vision can be improved by a rather substantial amount. However, the improvement that occurred in this study cannot be attributed solely to the indoor training given to the experimental subjects. It may be that peripheral training is context specific. Although the experimental subjects substantially improved their performance on the training task, there was no indication from the results that successful transfer to the driving situation occurred. Both the experimental and control subjects showed significant improvement in silhouette recognition performance (% correct recognition) between initial and final testing. Although the experimental subjects appeared to have improved more than the control subjects (16% vs. 10%), the difference was not statistically significant. The silhouette recognition tasks used for training and for testing in the van were very similar. The testing and training silhouettes differed only slightly in detail. Under these circumstances, if transfer of training is possible

it seems it would be revealed by the tests conducted in the present study. It cannot be claimed, however, that failure to find transfer effects means that they did not exist. This is essentially arguing from the null hypothesis, i.e., if a significant difference is not found the difference does not exist. It may be that the testing procedure which seemed superficially adequate may not have been sensitive enough to reveal the effects of transfer.

Wearing of Glasses

Throughout this study the wearing of glasses by subjects was a problem. Generally, the edges of the lenses and frames blocked out the area between 50° and 60° on the left and right sides of the peripheral field. For several subjects, whose glasses had midline bows, the entire horizontal meridian beyond 50° was blocked. To reduce this problem the subjects were asked to tilt their glasses so as to move the bows up and out of the horizontal meridian.

The adverse effect of glasses on peripheral vision for driving has been noted several times in the past. A recent study (Shinar, 1977) found that 40% of a random sample of 890 Indiana drivers were required to wear glasses for driving. Probably a significant additional percentage wear sunglasses while driving. If these drivers' glasses have midline bows, they are effectively blind beyond 50°. Under these circumstances it seems superfluous to be concerned with either testing or training of peripheral vision beyond 50° to the left and right and especially to set standards requiring peripheral vision in excess of a 100° full field.

CONCLUSIONS

The results from the present experiment lead to the following conclusions:

1. Significant improvements occurred in the ability of both the experimental and control subjects to recognize peripherally presented

vehicular silhouettes and to detect peripheral motion during driving.

2. The training course was effective in producing substantial improvements in the ability of the subjects to recognize vehicular silhouettes presented for short durations.
3. No evidence was found to support or refute the hypothesis that improvements in peripheral form recognition brought about by indoor training successfully transfers to other types of peripheral vision tasks or improves peripheral vision in the driving context.

III. SUMMARY AND GENERAL DISCUSSION

Experiment I revealed that a number of our initial procedural assumptions about the training and testing of peripheral vision were incorrect. Both the training and testing data obtained during this experiment were sparse and highly variable. Therefore, no conclusions other than methodological could be drawn from this experiment. However, the experience gained during the conduct of the first experiment provided valuable insights for the improvement of both the training and testing procedures. Specifically, the training technique was concluded to be inadequate primarily because the subjects were required to perform a central tracking task while being trained to detect low contrast circular discs of light projected in their peripheral field with simple reports by the experimenter of "right" or "wrong" constituting feedback. The difficulty of performing both of these tasks simultaneously, the generally boring nature of the peripheral detection task, and the abbreviated form of the feedback given to the subjects appeared mainly to fatigue the subjects, resulting in low motivation and, consequently, highly variable performance. Also, the total amount of training was judged to be inadequate.

The main procedural problems with the testing of peripheral vision while driving a vehicle on the highway were the failure to obtain a sufficient amount of data and the lack of experimenter control over the testing stimuli, which were presented on 8mm film. The film could not be readily started and stopped between presentations. If the driver was attending to some aspect of the driving task, such as looking at the instrument panel, a rearview mirror, or traffic conditions, a presentation was easily missed. Normally it would be preferable to have the driver responding to peripheral stimuli unalerted to their occurrence. But the testing time would have to be extended prohibitively to acquire sufficient data

to reduce the variability in performance due to missed presentations. The best compromise seemed to be to provide the experimenter with direct control over each presentation so that the driver-subject could be alerted and a presentation withheld if he was unavoidably distracted. A further disadvantage of having the stimuli on film was that the experimenter had no control over the variable of interest; for example, the rate of movement for a motion detection task. To accommodate differences in threshold for various subjects, a large range of stimulus values are necessarily required with sufficient stimuli for each value. If the experimenter has direct control over the stimulus values, however, the number of trials can be reduced by limiting the range of stimulus values to those near the subject's threshold. The inadequacies discovered in the preliminary experiment led to the modification of the training and testing procedures used in Experiments II and III.

Experiment II concentrated on demonstrating that peripheral vision can be improved through training. No consideration was given to testing peripheral vision during driving since the time required for pre- and posttesting in a vehicle is considerable and if it could not be shown that peripheral vision could be improved by training in the laboratory, the time and effort spent in testing for transfer of training during driving would be wasted. Thus, work was concentrated on developing effective training techniques.

The training procedure for Experiment II differed considerably from that used for Experiment I. The central tracking task was eliminated because of the fatiguing effects it had on the subjects. The peripheral training task was changed from detection of a low contrast disc to vehicular silhouette recognition. Single- and dual-silhouette presentations were used on alternate days of training and smaller silhouettes were used on the seventh and eighth days of training to add

variety and, hopefully, to help maintain the subject's interest. Kinetic perimetry tests were added to provide a second means of assessing improvement of peripheral vision other than performance on the training tasks themselves. The course of training was lengthened to 10 days to assure that improvements in peripheral vision could be obtained and also to determine if improvements through training reached an asymptote after a certain number of days of training. The experimenter became an active participant in the training course by encouraging the subjects, discussing the recognition of the silhouettes with them, providing more elaborate and supportive feedback on their performance, and generally trying to motivate the subjects to do well.

The training and testing was given to nine experimental subjects. Nine control subjects, divided into two groups, were tested in the same manner as the experimental subjects on two occasions separated by an interval equivalent to that of the training course.

Pre- and posttesting with the Mark I Integrated Vision Tester provided a simple means of assessing whether or not improvements in the use of peripheral vision were transferable to other types of peripheral visual tasks. Retention tests were given to the subjects to determine how much of the improvement realized through training would be evident after 2 months.

The results from Experiment II were highly successful. Significant and substantial amounts of improvement in recognition of vehicular silhouettes were evidenced by the experimental group with almost complete savings on the retention test. The control subjects showed no improvements at all. Neither group of subjects showed any significant improvement in performance on the tests in the Mark I Integrated Vision Tester. Lack of reliability of the Mark I tests may have been the reason that no significant improvements were found.

Because of this, and because the results of Mark I testing in general were highly variable, this device was not used in Experiment III.

An unexpected result of Experiment II was that the control group had much higher average performances on the tests than the experimental group. The only difference in the population from which these two groups of subjects were drawn was that the experimental subjects were all residents of a private retirement apartment complex. The control subjects were drawn from the general population through newspaper advertisements. It is possible that the difference in life style of the two groups of subjects somehow correlated with the differences in their peripheral vision performance.

Experiment III was essentially a replication of Experiment II with the addition of pre- and posttesting of peripheral vision while the subjects were actually driving to determine if improvements gained through training would successfully transfer to a driving situation. Also, a pre- and posttest of low contrast disc detection was administered to both experimental and control subjects to assure that both groups had comparable fundamental peripheral vision capabilities, and also to see if training on a more complex task, silhouette recognition, would cause improvements in detection performance.

The peripheral vision tests conducted while driving the research van were a vehicular silhouette recognition test and a motion detection test. These tests were administered to the experimental subjects four times, on 2 successive days prior to training and on 2 successive days after training. The control subjects also received the test four times with an interval of days equal to that of the training program interposed between the second and third tests. The performance measure was the percentage of correct recognitions at each of the three peripheral angles.

The motion detection test required the subject to recognize the side and the direction of rotation of either of two

Maltese cross-shaped targets made of random-dot material seen against small backgrounds of similar material. The targets were visible against their backgrounds only when they moved. Two targets, one on the left and one on the right side, were used at peripheral angles of 30° and 45°.

In addition to the tests conducted while driving, the motion detection tests were also performed with the van parked. The targets were located at 30° on the first day of testing and at 45° on the second day of testing. After training, or an equivalent time interval, the 2 successive days of motion detection testing were repeated. The experimenter would vary the rate of motion, either decreasing or increasing it, depending on whether the subject detected or failed to detect the movement of the target on the preceding trial. A motion threshold was computed by averaging the movement rates lying midway between the rates for correct detections and misses. Thresholds were computed separately for the left and right sides and only data after the first 16 presentations on each side were used to derive the threshold measures.

The experimental group showed significant and substantial improvement in their performance on the training tasks and the kinetic perimetry test. The results were almost identical to those obtained in Experiment II. There was no significant change in performance of either the experimental or control group on detection of the low contrast disc targets on subsequent retesting.

Substantial improvement in performance on the silhouette recognition test conducted during driving was realized by both the experimental and control subjects. This finding confirmed that it is in fact possible to improve the peripheral function of motor vehicle drivers. From the first day of pretesting to the last day of posttesting both the experimental and control subjects showed average increments in percent correct silhouette recognition of 16% and 10%, respectively. Although it appears that the experimental subjects showed more improvement

than the control subjects, the difference in improvement between the two groups was not statistically significant. In other words, there was no evidence to support the contention that the improvements in the ability to recognize peripherally presented vehicular silhouettes brought about by indoor training will successfully transfer to a similar task in the driving context.

Failure to find a significant difference between experimental and control groups does not lead to the conclusion that no difference existed. To do so would be a logical fallacy since it is possible that the experimental design was not optimum for detecting differences due to transfer of training. It is interesting to note, however, that no other studies of which we are aware have specifically addressed the question of whether training on one peripheral function will cause improvements in other peripheral functions. The only evidence found for generalization of peripheral training is anecdotal (Low, 1946). Because of the importance of this question for both practical and theoretical reasons, further research on whether training one peripheral function will transfer to others is warranted.

The results of the motion detection tests conducted during driving were similar to those for the silhouette recognition tests. There was a significant but small improvement in the ability of both the experimental and control groups to detect peripheral motion. No significant differences in this performance improvement between the experimental and control groups were found.

The most interesting result of the motion tests is revealed in the individual plots of motion detection performance shown in Appendix B. Most of the individual graphs show substantial variation of the apparent threshold value for motion detection. This is true for testing both when the van was parked and during driving. Most studies have reported peripheral threshold data in terms of an average

score. It seems evident that tracking peripheral performance over time is worthwhile since variation in performance over a period of a few minutes can be seen. It is doubtful that this variation is due to external distractions, fatigue, or some sort of vigilance decrement. The testing sessions were relatively short, on the order of 25 to 30 minutes, and the subject was alerted prior to each presentation. Change in attentional variables cannot definitely be ruled out, but neither can the possibility that fluctuations in sensitivity are an inherent characteristic of peripheral vision. Usually very little variation in performance is found in standard perimetry testing where a small spot of light is slowly moved inward or outward until its appearance or disappearance is reported by the subject. Generally, the results of this type of test are repeatable with very little change in performance from one session to another. The results of the low contrast disc detection is directly analogous to the results from a clinical perimetry test. The angle of detection for each subject was remarkably stable although the testing sessions were separated by approximately 12 days. It may be that peripheral sensitivity on essentially low-level sensory tests such as light detection are very stable and change only when secondary task loading is introduced or some stressor, either physical or psychological, is added. Significant random variation may only occur in more complex perceptual tasks such as silhouette recognition or motion detection. These speculations do not appear to have ever been the subject of experimental work.

IV. FINAL CONCLUSIONS AND RECOMMENDATIONS

1. Peripheral vision functions for recognition of vehicular silhouettes can be improved substantially in the driving context. This improvement appears to result from practice on the peripheral vision tests themselves. It is recommended that future research on the training of peripheral vision for driving address the question of what factors are critical for improvement of peripheral vision functions in the driving context.
2. Training on peripheral recognition of vehicular silhouettes produces substantial improvements in performance on this task in the training context. There is no evidence, however, that the improvements realized through indoor training transfer to the driving context.
3. Further research is necessary to determine what peripheral vision functions are important for driving and what the minimum field sizes or threshold criteria should be for these functions.

V. REFERENCES

- Abernethy, C. N., & Leibowitz, H. W. The effect of feedback on luminance thresholds for peripherally presented stimuli. *Perception & Psychophysics*, 1971, 10(3), 172-174.
- Allen, M. J. Vision and driving. *Traffic Safety*, September 1969, 8-9; 38-40.
- American Optical Company. 1969 Survey of state requirements for motor vehicle operators, Southbridge, MA; cited by Henderson & Burg (1974).
- Aulhourn, E., & Harms, H. Visual perimetry (Chap. 5). In H. Autrum, R. Jung, W. R. Loewenstein, D. M. MacKay, & H. L. Teuber (Eds.), *Handbook of sensory physiology* (Vol. VII/4). Berlin: Springer-Verlag, 1972.
- Bahrack, H., Fitts, D., & Rankin, R. E. Effects of incentives upon reactions to peripheral stimuli. *Journal of Experimental Psychology*, 1952, 44, 400-406.
- Baird, J. W. The contraction of the color zones in hysteria and in neurasthenia. *Psychological Bulletin*, 1906, III(8), 249-254.
- Bodis-Wollner, I. A distractive effect of peripheral attention on foveal trigram recognition. *Perception*, 1973, 2, 407-413.
- Borish, I. M. *Clinical Refraction* (3rd ed.). Chicago: Professional Press, 1970.
- Botwinick, J. Geropsychology. *Annual Review of Psychology*, 1970, 21, 239-272.
- Botwinick, J. *Aging and behavior*. New York: Springer, 1973.
- Burg, A. *The relationship between vision test scores and driving record: General findings* (Report No. 67-24). Los Angeles: University of California, Institute of Transportation and Traffic Engineering, Department of Engineering, 1967.
- Burg, A. Lateral visual field as related to age and sex. *Journal of Applied Psychology*, 1968, 52(1), 10-15.
- Bursill, A. E. Restriction of peripheral vision during exposure to hot and humid conditions. *Quarterly Journal of Experimental Psychology*, 1956, 10, 113-129.

- Chown, S. M., & Heron, A. Psychological aspects of aging in man. *General Review of Psychology*, 1965, 16, 416-450.
- Cornsweet, D. M. Use of cues in the visual periphery under conditions of arousal. *Journal of Experimental Psychology*, 1969, 80, 14-18.
- Cornsweet, T. N. The staircase method in psychophysics. *American Journal of Psychology*, 1962, 75, 485-491.
- Danielson, R. W. The relationship of fields of vision to safety in driving. *American Journal of Ophthalmology*, 1957, 44; cited by Kite & King (1961).
- Dobrowolsky & Gaine. Uber die Sehschärfe (Formsinne) an die Peripherie der Netzhaut. *Pflügers Archiv f.d.ges. Physiol.*, 1875, 12, 411-432; cited by Low (1950).
- Eames, T. H. A study of tubular and spiral central fields in hysteria. *American Journal of Ophthalmology*, 1947, 30, 610-611.
- Edwards, A. L. *Experimental design in psychological research* (3rd ed.). New York: Holt, 1968.
- Engel, F. L. Visual conspicuity, directed attention and retinal locus. *Vision Research*, 1971, 11, 563-576.
- Franz, S. I., & Morgan, R. C. Studies in cerebral function: III. Transfer of effects of learning from one retinal area to other retinal areas. *Publ. University of California, Los Angeles, Educ., Phil. Psych.*, 1933, 1, 91-98.
- Gasson, A. P., & Peters, G. S. The effect of concentration upon the apparent size of the visual field in binocular vision. *The Optician*, Part I, January 1, 1965, 660-663; Part II, January 8, 1965, 5-12.
- Graham, C. H. (Ed.) *Vision and visual perception*. New York: Wiley, 1965.
- Grindley, G. C., & Townsend, V. Voluntary attention in peripheral vision and its effects on acuity and differential thresholds. *Quarterly Journal of Experimental Psychology*, 1968, 20, 11-19.
- Haines, R. F. A review of peripheral vision capabilities for display layout designers. *Proceedings of the S.I.D.*, 1975, 16(4).
- Henderson, R. L., & Burg, A. *The role of vision and audition in truck and bus driving* (TM[L]-5260/000/00). Santa Monica: System Development Corporation, 1973.

- Henderson, R. L., & Burg, A. *Vision and audition in driving* (TM[L]-5297/000/00). Santa Monica: System Development Corporation, 1974.
- Henderson, R. L., Burg, A., & Brazelton, F. A. *Development of an integrated vision testing device: Phase I final report* (TM[L]-4848/000/00). Santa Monica: System Development Corporation, 1971.
- Hills, B. L. *Some studies of movement perception, age and accidents* (Suppl. Rep. 137UC). Berkshire, England: Transport and Road Research Laboratory, 1975. (Paper presented at 1st International Congress on Vision and Road Safety, Paris, February 1975.)
- Hockey, G. R. J. Effect of loud noise on attentional selectivity. *Quarterly Journal of Experimental Psychology*, 1970a, 22, 28-36.
- Hockey, G. R. J. Signal probability and spatial location as possible bases for increased selectivity in noise. *Quarterly Journal of Experimental Psychology*, 1970b, 22, 37-42.
- Hurst, A. F., Oxon, M. D., & Symns, J. L. M. Narrow and spiral fields of vision in hysteria, malingering, and neurasthenia. *British Journal of Ophthalmology*, 1919, 3(17), 17-21.
- Johnson, C. A., & Leibowitz, H. W. Practice, refractive error, and feedback as factors influencing peripheral motion thresholds. *Perception & Psychophysics*, 1974, 15(2), 276-280.
- Julesz, B. *Foundations of cyclopean perception*. Chicago: University of Chicago Press, 1971.
- Kite, C. R., & King, J. N. A survey of the factors limiting the visual fields of motor vehicle drivers in relation to minimum visual field and visibility standards. *British Journal of Physiology & Optics*, 1961, 18, 85-107.
- Kobrick, J. L. Effects of hypoxia on voluntary response time to peripheral stimuli during central target monitoring. *Ergonomics*, 1972, 15(2), 147-156.
- Kobrick, J. L. Effects of hypoxia on peripheral visual response to rapid sustained stimulation. *Journal of Applied Physiology*, 1974, 37(1), 75-79.
- Kobrick, J. L., & Appleton, B. Effects of extended hypoxia on visual performance and retinal vascular state. *Journal of Applied Physiology*, 1971, 31(3), 357-362.

- Kobrick, J. L., & Dusek, E. R. Effects of hypoxia on voluntary response time to peripherally located visual stimuli. *Journal of Applied Physiology*, 1970, 29(4), 444-448.
- LeGrand, Y. *Form and space vision*. Bloomington: Indiana University Press, 1967.
- Leibowitz, H. W., & Appelle, S. The effect of a central task on luminance thresholds for peripherally presented stimuli. *Human Factors*, 1969, 11, 387-392.
- Low, F. N. The peripheral visual acuity of 100 subjects. *American Journal of Physiology*, 1943, 140, 83-88.
- Low, F. N. Some characteristics of peripheral visual performance. *American Journal of Physiology*, 1946, 146, 573-584.
- Low, F. N. The peripheral motion acuity of 50 subjects. *American Journal of Physiology*, 1947a, 148, 124-133.
- Low, F. N. Peripheral visual acuity of 55 subjects under conditions of flash presentation. *American Journal of Physiology*, 1947b, 151, 319-324.
- Low, F. N. *Peripheral visual acuity: A review*. Washington, DC: Office of Naval Research, Human Resources Division, 30 June 1950.
- Mackworth, N. H. Visual noise causes tunnel vision. *Psychonomic Science*, 1965, 3, 67-68.
- McColgin, F. H. Movement thresholds in peripheral vision. *Journal of the Optical Society of America*, 1970, 50, 774-779.
- McFarland, R. A. The psychological aspects of aging. *Bulletin of the New York Academy of Medicine*, 1956, 32, 14-32.
- McFarland, R. A., Evans, J. N., & Halperin, M. H. Ophthalmic aspects of acute oxygen deficiency. *Archives of Ophthalmology*, 1941, 26, 886-913.
- Moskowitz, H., & Sharma, S. Effects of alcohol on peripheral vision as a function of attention. *Human Factors*, 1974, 16(2), 174-180.
- National Academy of Sciences. *First interprofessional standard for visual field testing* (Report of Working Group 39). Washington, DC: National Academy of Sciences, National Research Council Committee on Vision, 1975.

- Putz, V. R., & Rothe, R. Peripheral signal detection and concurrent compensatory tracking. *Journal of Motor Behavior*, 1974, 6, 155-163.
- Reeder, J. E. The psychogenic color field. *American Journal of Ophthalmology*, 1944, 27, 358-361.
- Reeves, F. B., & Bergum, B. O. Perceptual narrowing as a function of peripheral cue relevance. *Perceptual and Motor Skills*, 1972, 35, 719-724.
- Renshaw, S. The visual perception and reproduction of forms by tachistoscopic methods. *The Journal of Psychology*, 1945, 20, 217-232.
- Richards, O. W. Visual needs and possibilities for night driving: Part 3. *The Optician*, December 1, 1967.
- Ronchi, L. Time course of perception probability under prolonged testing at various eccentricities. *Vision Research* 1970, 10, 605-607.
- Ronchi, L., & Viliani, G. *On some factors affecting the time course of sensitivity under prolonged stimulation* (N. 1492). Florence, Italy: Istituto Nazionale di Ottica, 1973. (NTIS No. AD-764 309)
- Sailor, A. L. Effect of practice on expansion of peripheral vision. *Perceptual and Motor Skills*, 1973, 37, 720-722.
- Sanders, A. F. *The selective process in the functional visual field*. Soesterberg, Netherlands: Institute for Perception, RVO-TNO, 1963.
- Saugstad, P., & Lie, I. Training of peripheral visual acuity. *Scandinavian Journal of Psychology*, 1964, 5, 218-224.
- Shinar, D. *Driver visual limitations diagnosis and treatment* (Contract No. DOT-HS-5-1275). Bloomington: Indiana University, Institute for Research in Public Safety, 1977.
- Webster, R. E., & Haslerud, G. M. Influence on extreme peripheral vision of attention to a visual or auditory task. *Journal of Experimental Psychology*, 1964, 68, 269-272.
- Weltman, G., Smith, J. E., & Egstrom, G. H. Perceptual narrowing during simulated pressure-chamber exposure. *Human Factors*, 1971, 13(2), 99-107.
- Wolf, E. Effects of age on peripheral vision. *Highway Research Board Bulletin*, 1962, No. 298, 26-32.

- Wolf, E., & Nadroski, A. S. Extent of the visual field: Changes with age and oxygen tension. *Archives of Ophthalmology*, 1971, 86, 637-642.
- Yasuna, E. R. Hysterical amblyopia: Its differentiation from malingering. *American Journal of Ophthalmology*, 1946, 29, 570-578.
- Zahn, J. R., & Haines, R. F. The influence of central search task luminance upon peripheral visual detection time. *Psychonomic Science*, 1971, 24(6), 271-273.

APPENDIX A
DESCRIPTION OF MARK I
INTEGRATED VISION TESTER TESTS

INTRODUCTION

The following descriptions of the Mark I Vision Tester tests were extracted verbatim from Henderson and Burg (1974). Only those tests used in the present research are reported. The procedures used were the same as described herein. The luminance values reported were not remeasured but since no modifications were made to the equipment and testing took place in a dark room, the luminance values reported are assumed to be correct.

FUNCTIONAL DESCRIPTION OF THE TESTS

Except for the tests of movement threshold described below, the stimuli for all other tests consist of Landolt rings--circles with a break in them. In the current test configuration, the location of the break can be at any of four positions, e.g., at the top, the right, the bottom, or the left. The size of the break in the circle is always equal to the stroke width of the circle, and the outside diameter of the circle is always equal to five times the stroke width. These relationships are all illustrated below.

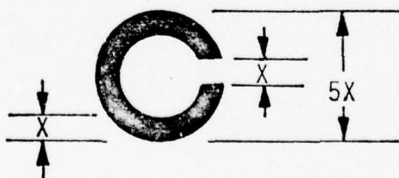

To keep the overall size of the device within practical limits, all test targets are presented at a nominal 20 inches from the observer's eyes. To prevent penalizing older drivers who may not be able to focus (accommodate) on an object at that distance, and to simulate distances important to the driving task, supplemental lenses are used to make stimuli

at 20 inches appear to be at optical infinity (assumed by convention to be 20 feet or more). This is common practice in all compact vision test devices, and is usually accomplished with fixed optics. However, since freedom of head movement is required by certain of the tests in this device, these supplemental lenses are provided in conventional spectacle frames for those who do not normally wear eye glasses, and in clip-on frames for those who do.

In the following paragraphs, a functional description of each test is presented.

STATIC ACUITY - NORMAL ILLUMINATION (SA-Norm)

The ability of the eye to resolve detail in a stationary object is measured by presenting to the subject a series of Landolt rings, calibrated in size to correspond, in terms of the angular subtense of the break in the circle, to the Snellen system of notation, e.g., 20/20, 20/40, etc. A series of rings of graduated size is presented to the observer with instructions to call out the location of the break in each circle beginning with the largest (20/175 equivalent) and going toward the smallest (20/20 equivalent). The Snellen equivalent of the smallest circle in which the gap position is correctly identified at least four out of the six times is the subject's static acuity score.

The test targets used have a brightness of 2.3 foot Lamberts (fL), and a background brightness of .019 fL, yielding a contrast of 0.99.

CENTRAL ANGULAR MOVEMENT (CAM)

This test measures the speed with which an object must be moving in a lateral direction relative to the observer for him to detect this movement. The object (target) in this case is a white disc on a dark background. The disc subtends a visual angle of 2 degrees. In each presentation, it is shown as a moving target for a duration of 1 second, followed

by a 2-second "off" period in which the observer verbally reports the direction of movement (either "left" or "right"), followed by the next stimulus presentation, etc. This cycle is repeated 20 times, with the direction of movement selected at random. The 20 trials are divided into two series of 10 trials each. Each series begins with a rate of target movement that is very large--256 minutes of arc per second. Each successive presentation within a series involves less and less angular movement, with the tenth trial in each series representing just 2 minutes of arc per second, a rate of movement too small for most observers to detect. Each series follows the same movement sequence in terms of rate, but counter-balances direction of movement. The rates of movement used are as follows: 128, 64, 32, 16, 12, 8, 6, 4, and 2 minutes of arc per second. The lower rates of movement were too small for most subjects to detect. The subject was instructed to respond "left" or "right" after each presentation, but was permitted to say "can't tell" if he was unable to detect movement.

Targets for this test are presented by means of a motion picture projector. To obtain the necessary control over image size, test film was prepared by a precision animation camera using techniques developed in the motion picture industry. The white disc test target, when back-projected into the viewing screen, has a brightness of .02 fL, and the background brightness immediately surrounding the test target is .0045 fL, yielding a contrast of .79.

Two scores are recorded on this test. One measure is the total number of correct responses (CAM-Tot); the other is an estimate of the minimum amount of movement reliably detected (CAM-Thr).

CENTRAL MOVEMENT-IN-DEPTH (CMD)

The ability to perceive rate-of-closure on an object under restricted visibility conditions wherein the primary

cue is change in image size is measured in much the same way as perception of angular movement described above. In this test, however, instead of moving left or right with each presentation, the white disc either grows larger or smaller. In every stimulus presentation, the initial target size is 2° of visual angle, and it either expands or contracts during the 1-second presentation time. Again, a total of 20 trials are presented in two series of ten each. Also, each succeeding presentation within a series involves less and less movement and covers a range of 190 minutes of arc per second to 2 minutes of arc per second change in image size, in the same increments described for the angular movement test. Target brightness and contrast ratio are identical to those for the CAM test.

Recorded scores are again the total number of correct responses (CMD-Tot) and threshold measures recorded separately for targets growing smaller (CMD-Thr Small) and larger (CMD-Thr Large).

USEFUL PERIPHERAL VISION

To obtain a measure of the ability to use information derived from the peripheral field of view without directing foveal vision on the object or event, the movement tests (both angular and in-depth) described above are presented to the observer in his peripheral field of view. To ensure that the observer does not move his eyes to look directly at the test target, a secondary task is introduced simultaneously that requires continued fixation on a point 45° laterally removed from the test targets. At this fixation point, either to the left or the right of the test target, are two very tiny and very dim light sources. Only one of the lights is illuminated at any given time. On a random periodic basis, the light currently on is extinguished, and the other light turned on. If the observer is looking directly at the light when this occurs, he perceives a slight

"jump" in the light source. If, however, he has moved his eyes from the fixation point, he fails to see the apparent "jump" in the light source. The secondary task required of the observer is to monitor this fixation light and press a switch each time he detects a "jump." Failure to push the switch immediately after a "jump" occurs results in a momentary burst of a high frequency tone. In practice, the primary and secondary tasks are started simultaneously. The observer is required to divide his attention between the moving targets in his peripheral field, calling out the direction of movement, and the tiny light he is fixating on, pressing the switch each time it "jumps" to prevent the tone from sounding. Sounding of the tone signals to the observer that he has failed to detect a "jump" of the fixation light and indicates to the examiner, particularly if the tone sounds frequently, that the observer may be trying to "cheat" on the test by looking directly at the test targets instead of viewing them out of the corner of his eye, as he has been instructed to do.

Scoring of the moving targets is accomplished in the same way as described earlier for central presentation of the stimuli. The measures recorded are Peripheral Angular Movement total and threshold (PAM-Tot and PAM-Thr) and Peripheral Movement-in-Depth total and thresholds (PMD-Tot, PMD-Thr Small and PMD-Thr Large). In addition, the number of times the tone sounds is recorded. Half of the test is conducted with the fixation point located 45° to the right of the test target; the other half has the fixation light to the left.

FIELD OF VIEW

A measure of field of view is obtained by requiring the observer to fixate a point straight ahead, and respond to a series of short-duration lights introduced at random locations in his peripheral field. The observer simply reports when

he sees a light, either to his left or right. The lights appear either to the left or right from 30° to 90° (in 10° increments) laterally and within ±15° vertically from the fixation point. Brightness of all test lights is 2.2 fL with a background brightness less than .001 fL, the lowest level the Pritchard Photometer used for this purpose was capable of measuring. The lights are presented twice at each location and the score is total number correct (Field-Correct) and the maximum lateral angular extent (in degrees), both left and right, at which *both* presentations of the light were detected (Field-Extent).

EYE MOVEMENT AND FIXATION TEST

This test measures the individual's overall ocular-motor control capability and, in part, his peripheral vision. It requires the observer to detect the presence of a Landolt ring target in his peripheral field, acquire the target by quickly moving his eyes (and head in some instances) so that he may look directly at the target, and identify the position of the gap in the ring, all during the very brief period that the target is present. Because it does require *Detection, Acquisition, and Identification*, the test is termed DAI. Two versions of this test have been employed, varying only in the angular extent within which the test targets may appear.

In the test, the subject fixates a small white triangle directly in front of him. He is instructed that when the triangle disappears, a test target will appear somewhere in his field of view and remain "on" for a very brief period (1 second). His task is to detect and fixate upon the target, and verbally report the location of the gap in the Landolt ring before the target disappears. He is then to return his eyes to the center triangle and await the next target. In one version of the test, a total of 14 stimuli are presented at the same locations as described previously for the Field

Test. (In practice, the DAI test lights actually constitute the test stimuli for the Field Test.) Since the maximum lateral extent is 90° , this is termed the DAI 90° test. Two measures are recorded--total number correct (DAI 90° -Correct) and the maximum lateral angular extent in degrees at which both trials are correct (DAI 90° -Extent).

In the second version of the test, all test targets appear within $\pm 35^\circ$ of the central fixation triangle. This test is used to obtain a purer measure of eye movement capability, in that the targets may be seen without moving the head. Targets are used as in the first version, but the "on" time of each is reduced to 0.5 seconds. Test stimuli are presented both to the left and to the right, ranging from 10° to 35° off center in 5° increments. The score on this test is the total number correct (DAI 35° -Correct) and the maximum lateral angular extent in degrees at which the location of the gap in the Landolt ring is correctly identified (DAI 35° -Extent).¹

TEST PROCEDURES

The procedures followed in administering the tests are simple and straightforward. The person to be tested is seated at the device and the height of his chair adjusted to ensure that he is comfortable and properly aligned with the viewing aperture of the device. He is then fitted with the appropriate type of supplemental lenses and shown the proper head position for the tests.

The lights in the room are then extinguished and the recorded instructions started.² Normally, no verbal interaction

¹In the original work (Henderson & Burg, 1974), this test extended to 40° . A subsequent modification of the equipment reduced the range to 35° .

²A low voltage light is used by the experimenter to illuminate his control panel and response form; however, this light is shielded from the subject's eyes.

between the subject and the experimenter is required once the instructions begin. However, the experimenter can stop the recorded instructions and/or the tests at any point at which he feels the subject needs additional clarification, and start up again when satisfied the subject understands the tests. All responses to the vision tests are made verbally, and are recorded by the examiner.

APPENDIX B

GRAPHS OF MOTION DETECTION TEST PERFORMANCE FOR INDIVIDUAL SUBJECTS IN EXPERIMENT III

The following figures present motion detection performance data for individual experimental subjects (Figures B-1 to B-32) and control subjects (Figures B-33 to B-64). Above each graph is printed information describing the subject (experimental, "EXP 1" to "EXP 8," or control, "CNT 1" to "CNT 8"), the driving condition (vehicle stationary, "STATIC," or subject driving, "MOVING"), the prevailing weather, the angular position of motion target (30° or 45°), as well as time of day and traffic conditions where appropriate.

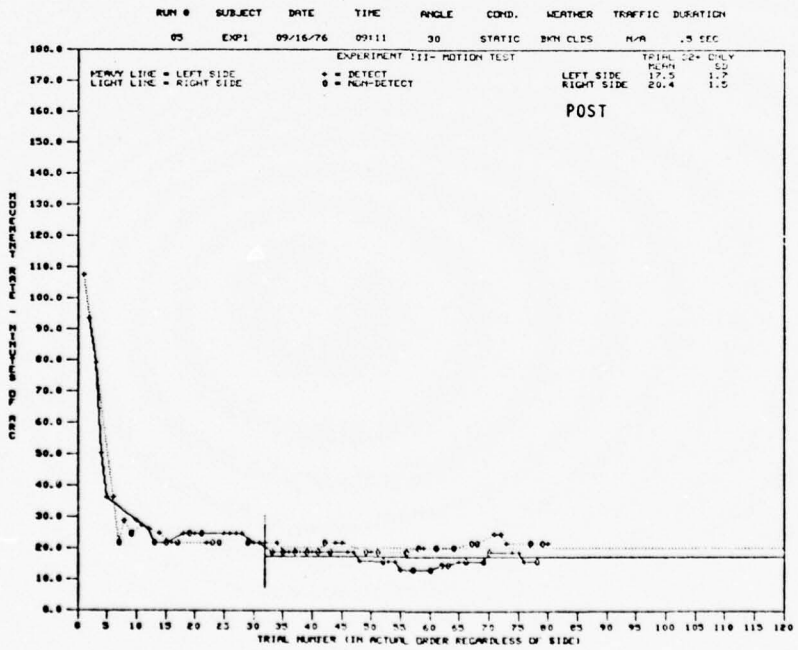
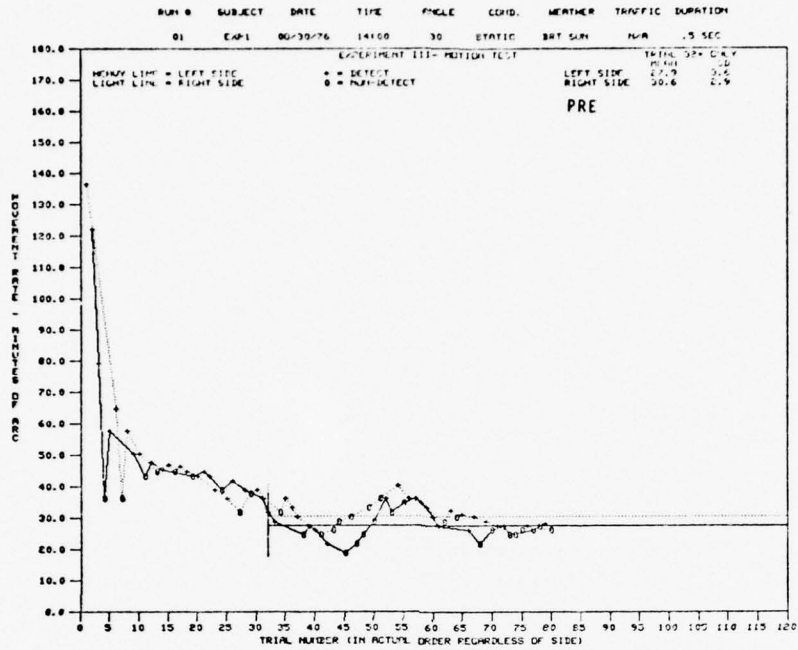

Figure B-1. Motion detection performance for pretesting (upper graph) and posttesting (lower graph). Mean thresholds are indicated by horizontal straight lines.

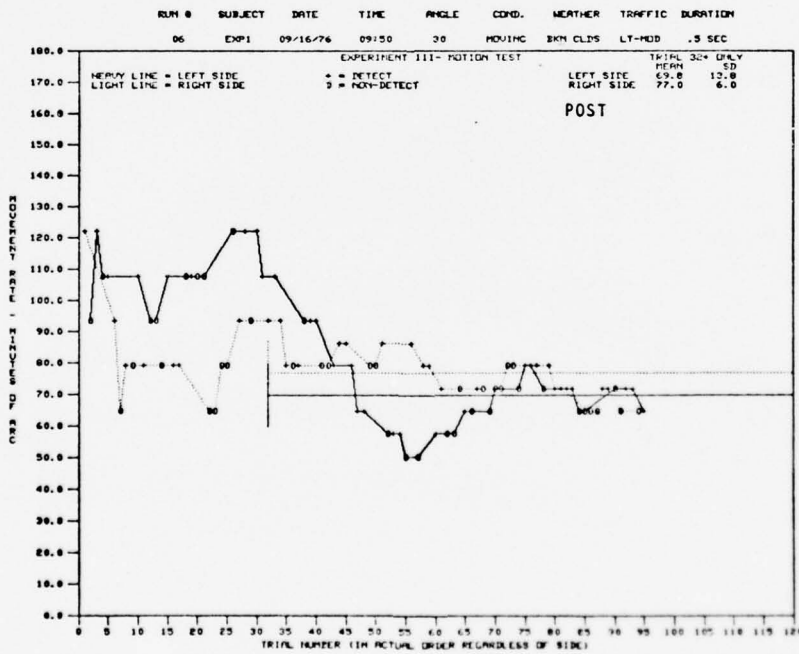
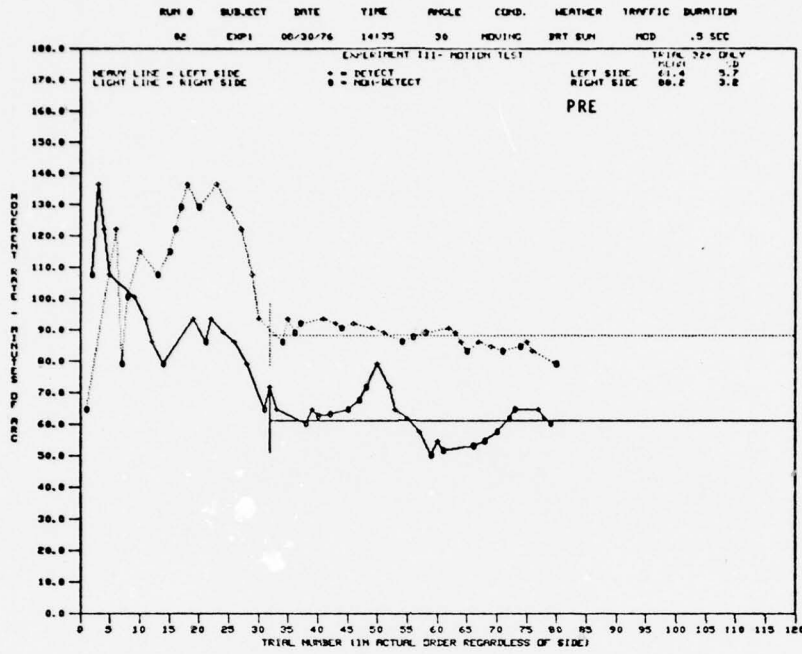

Figure B-2. Motion detection performance for pretesting (upper graph) and posttesting (lower graph). Mean thresholds are indicated by horizontal straight lines.

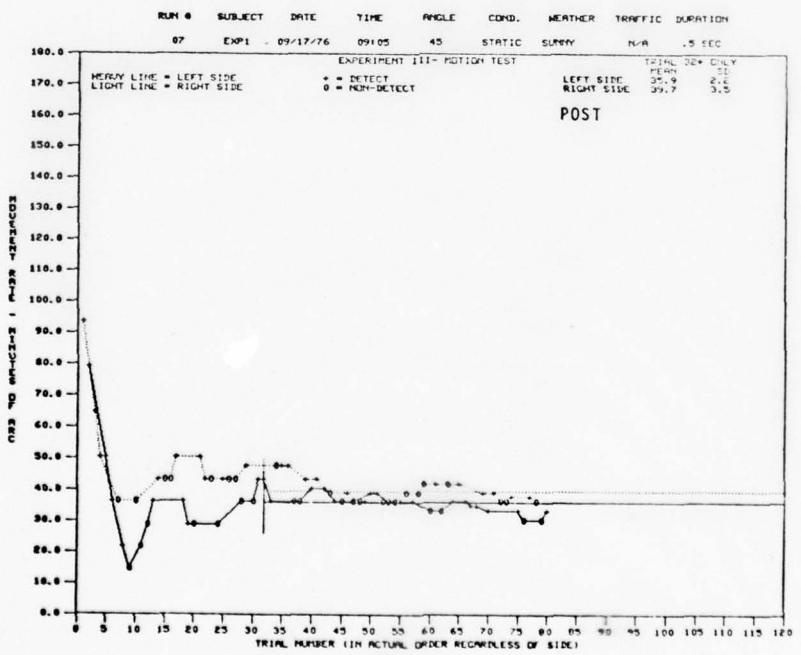
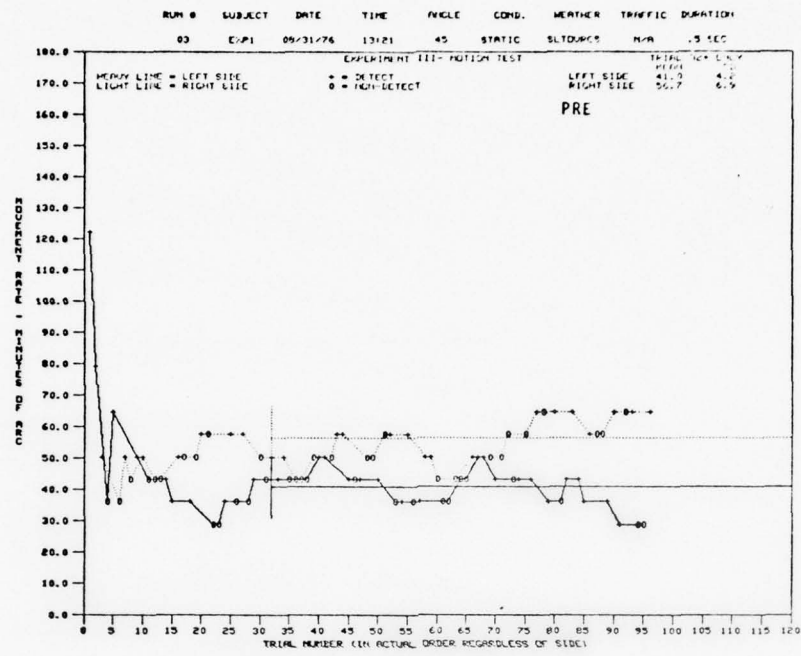

Figure B-3. Motion detection performance for pretesting (upper graph) and posttesting (lower graph). Mean thresholds are indicated by horizontal straight lines.

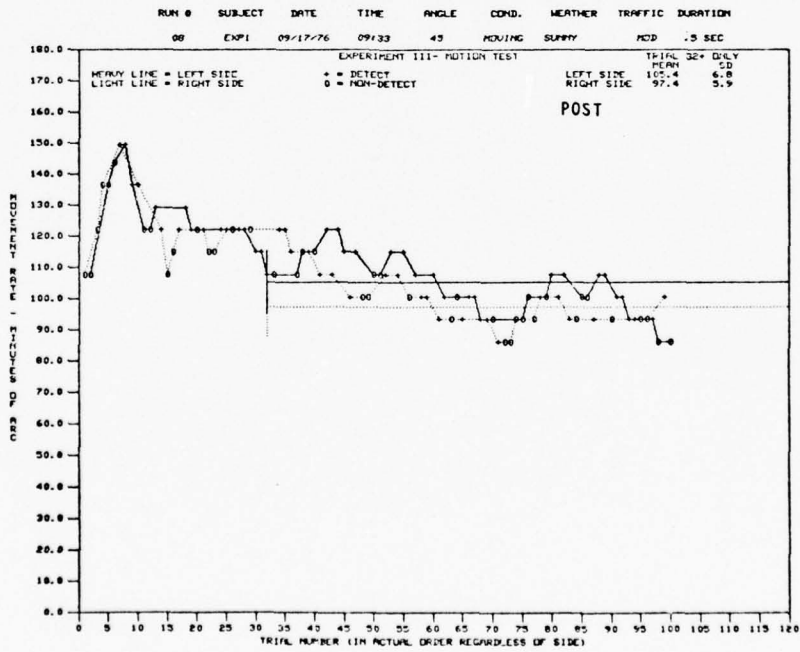
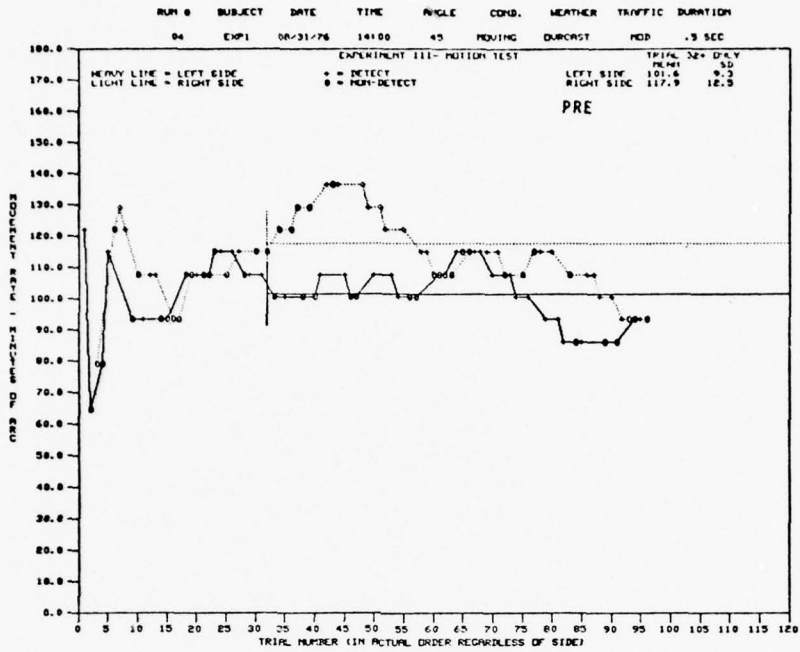

Figure B-4. Motion detection performance for pretesting (upper graph) and posttesting (lower graph). Mean thresholds are indicated by horizontal straight lines.

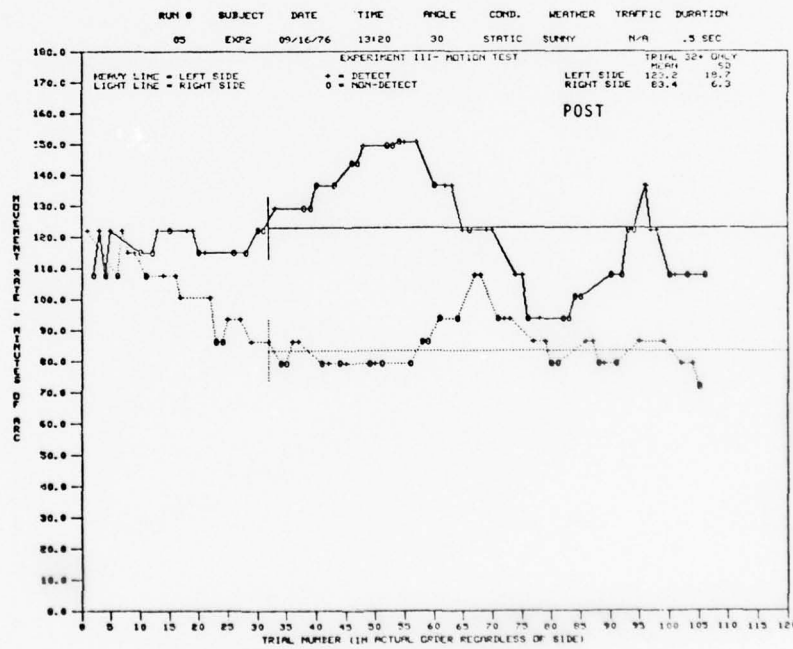
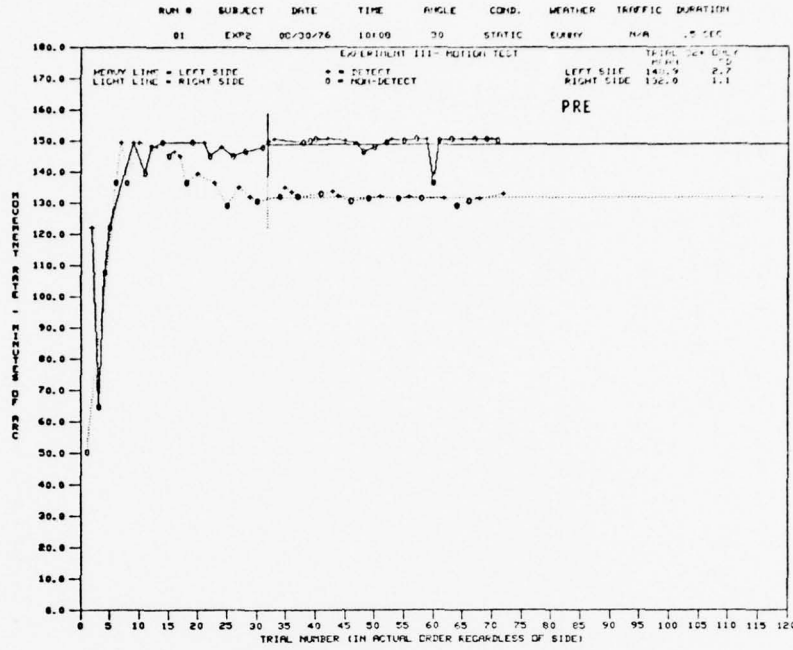

Figure B-5. Motion detection performance for pretesting (upper graph) and posttesting (lower graph). Mean thresholds are indicated by horizontal straight lines.

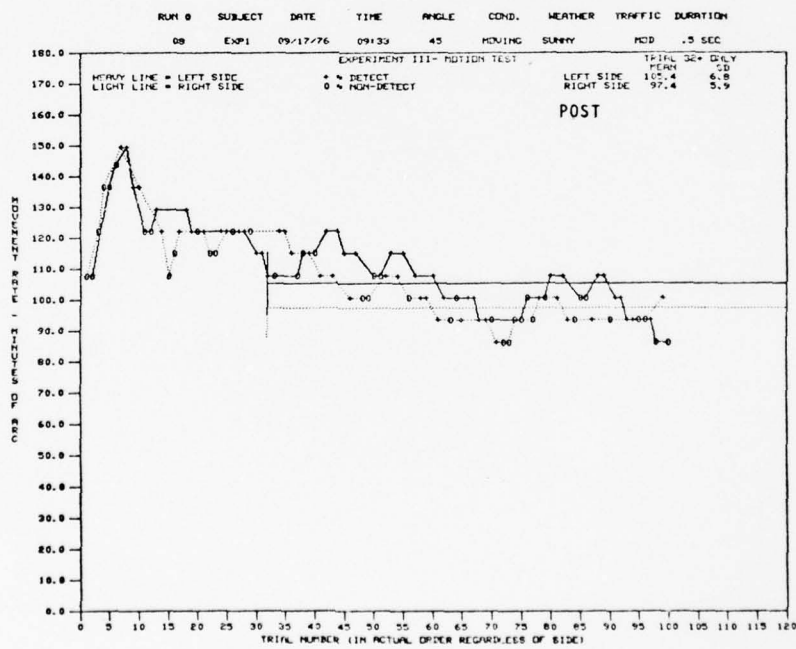
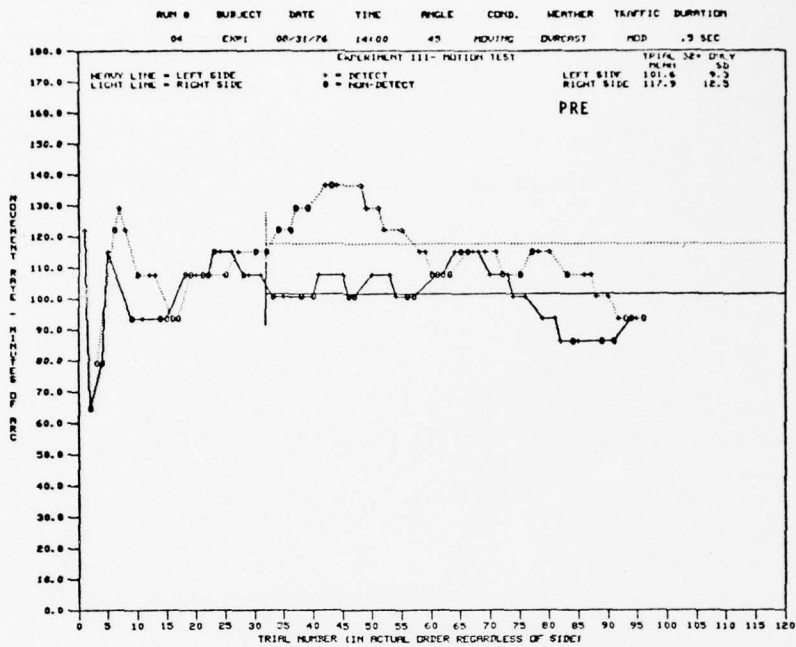

Figure B-4. Motion detection performance for pretesting (upper graph) and posttesting (lower graph). Mean thresholds are indicated by horizontal straight lines.

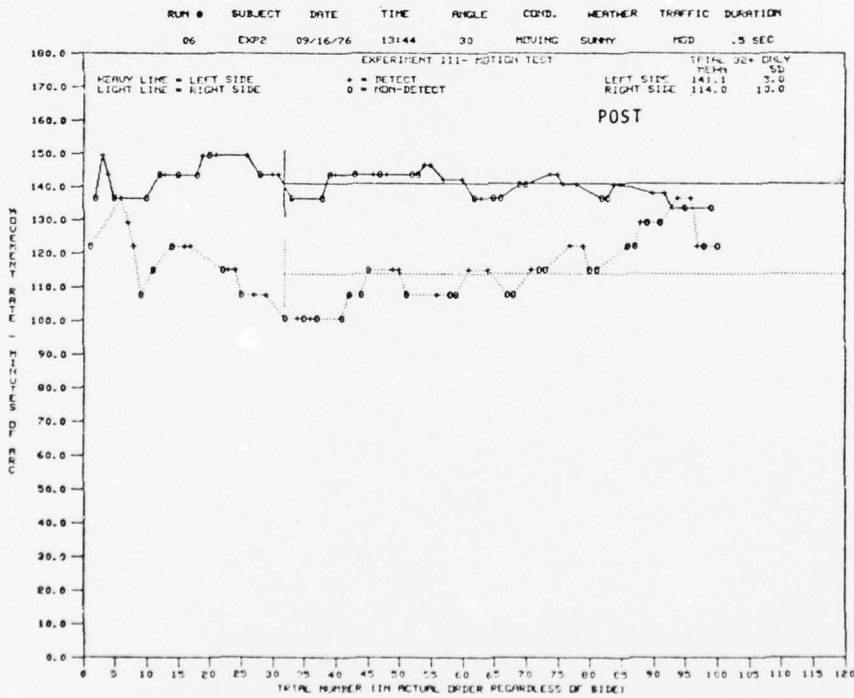
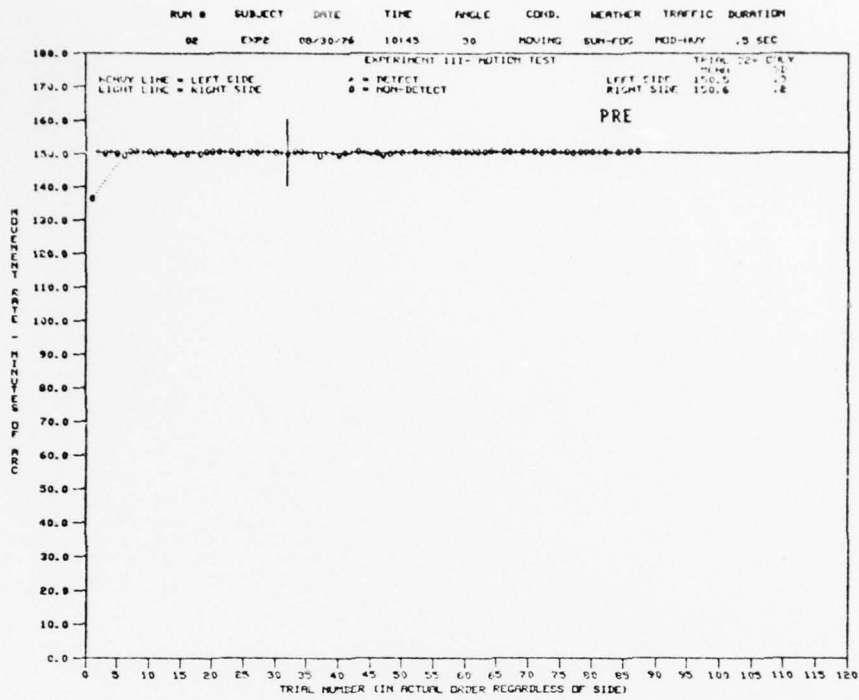

Figure B-6. Motion detection performance for pretesting (upper graph) and posttesting (lower graph). Mean thresholds are indicated by horizontal straight lines.

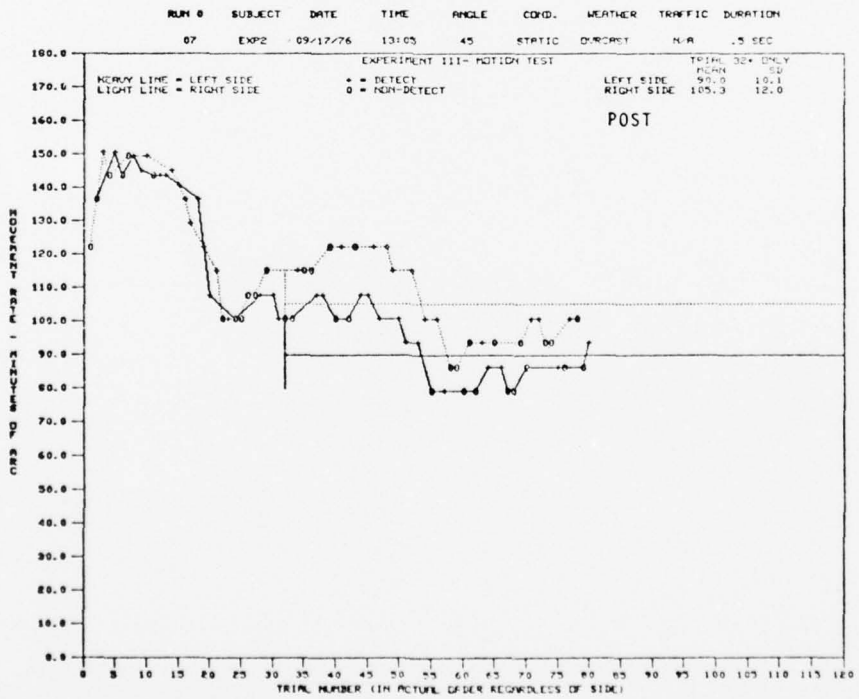
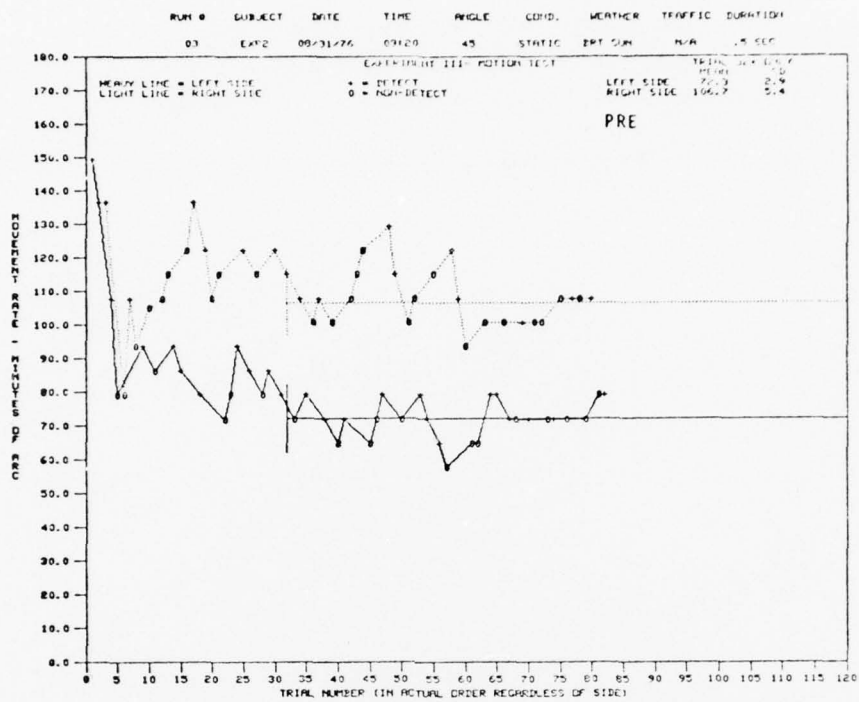

Figure B-7. Motion detection performance for pretesting (upper graph) and posttesting (lower graph). Mean thresholds are indicated by horizontal straight lines.

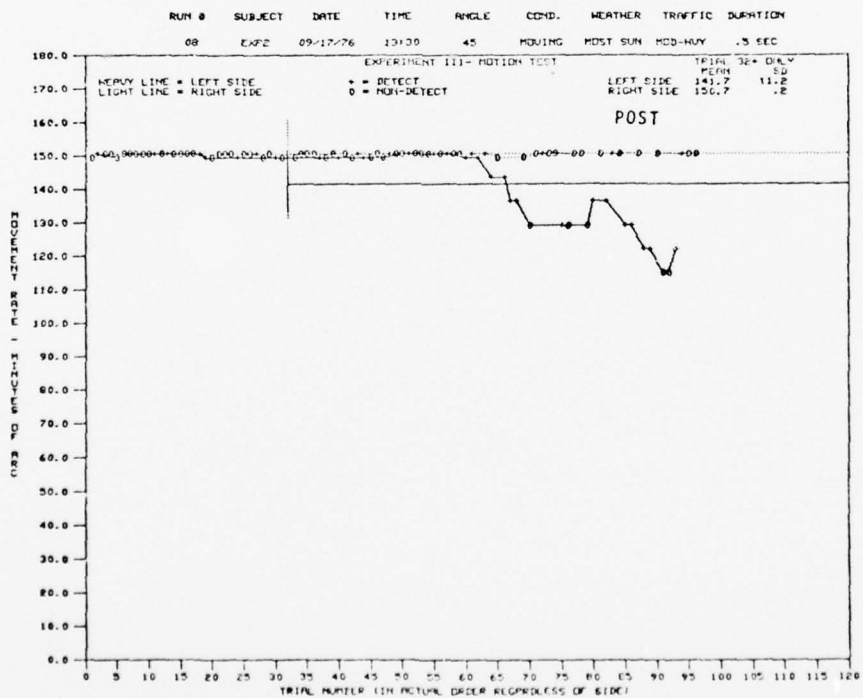
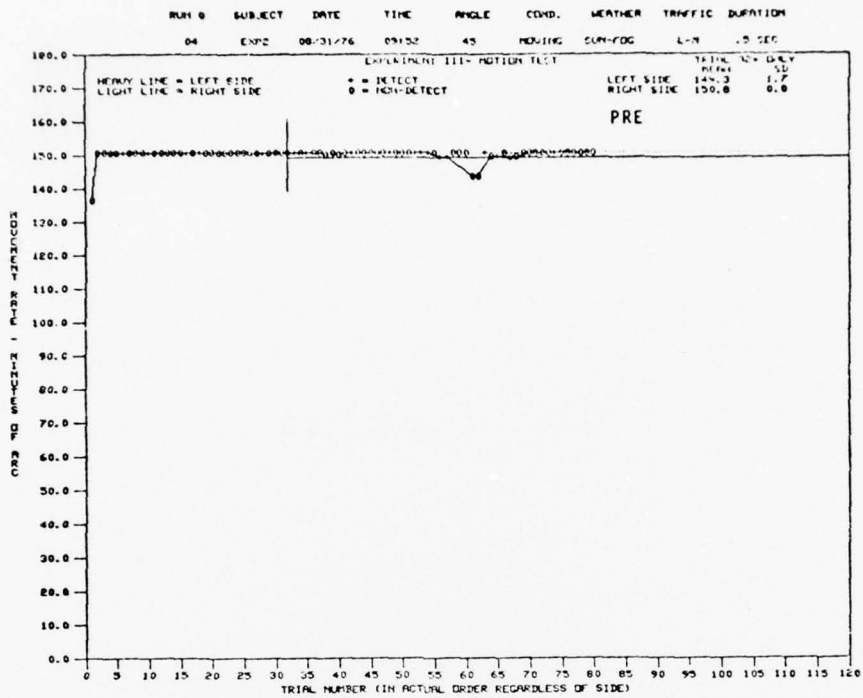

Figure B-8. Motion detection performance for pretesting (upper graph) and posttesting (lower graph). Mean thresholds are indicated by horizontal straight lines.

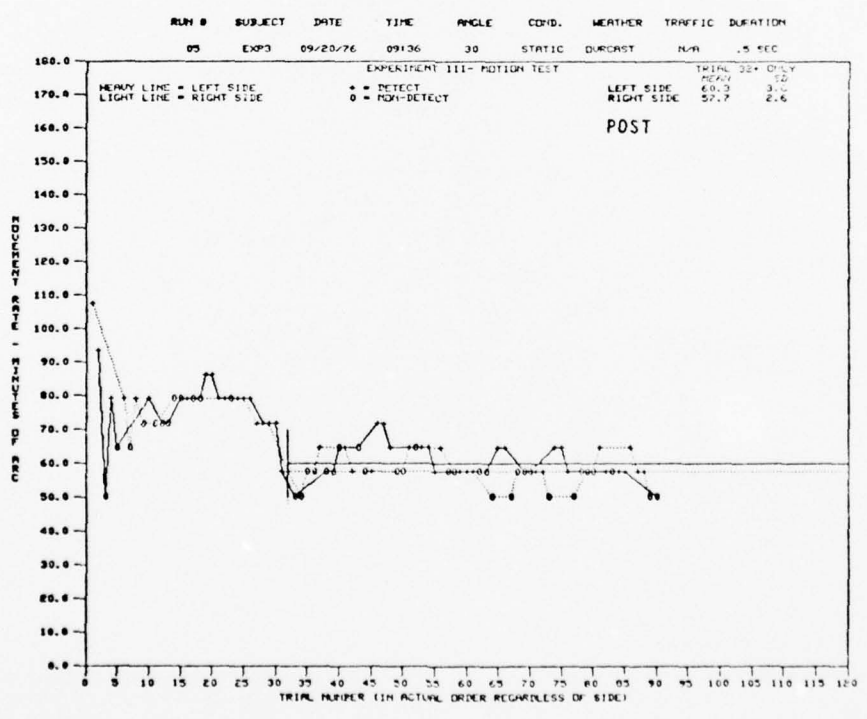
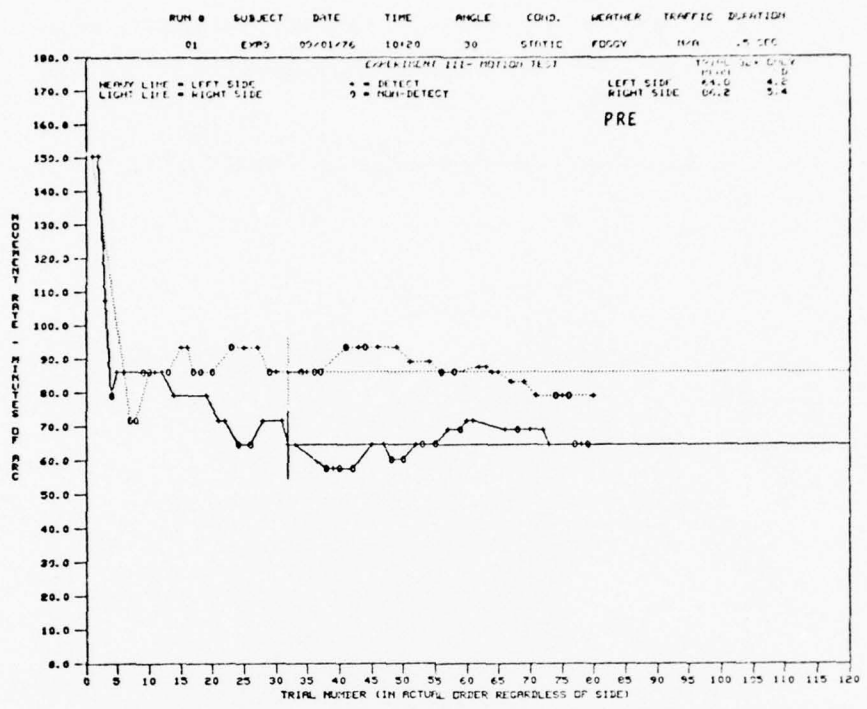

Figure B-9. Motion detection performance for pretesting (upper graph) and posttesting (lower graph). Mean thresholds are indicated by horizontal straight lines.

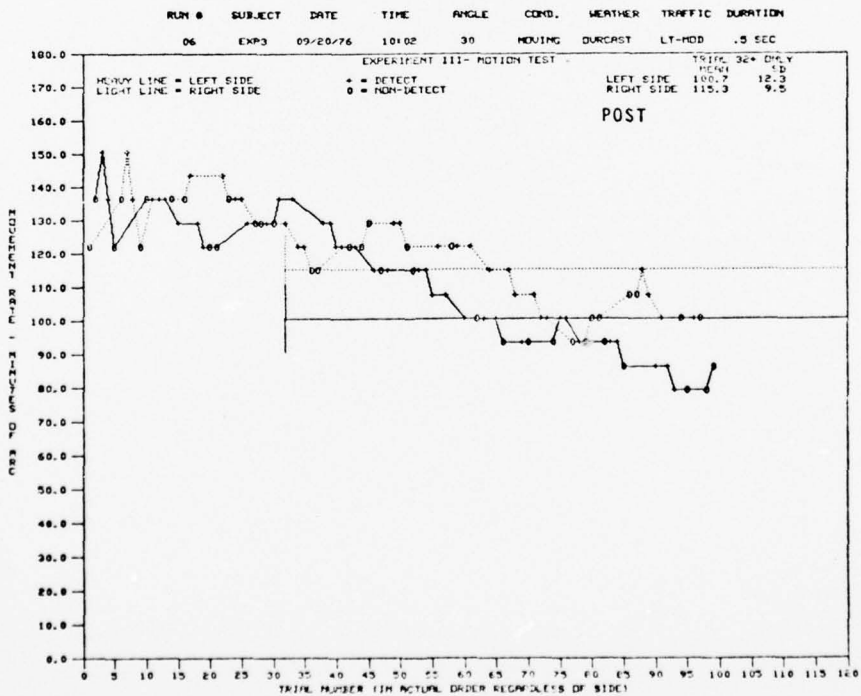
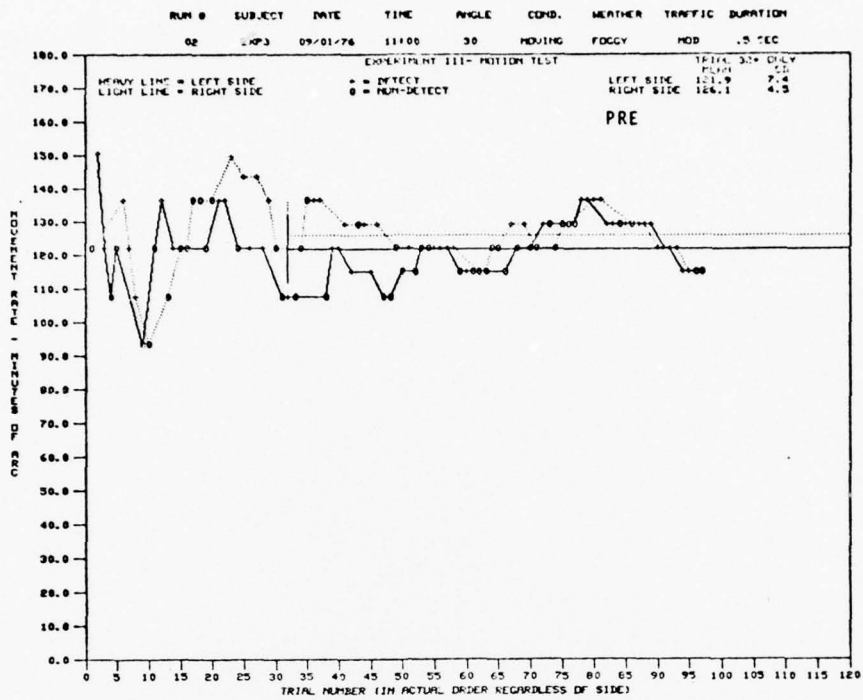

Figure B-10. Motion detection performance for pretesting (upper graph) and posttesting (lower graph). Mean thresholds are indicated by horizontal straight lines.

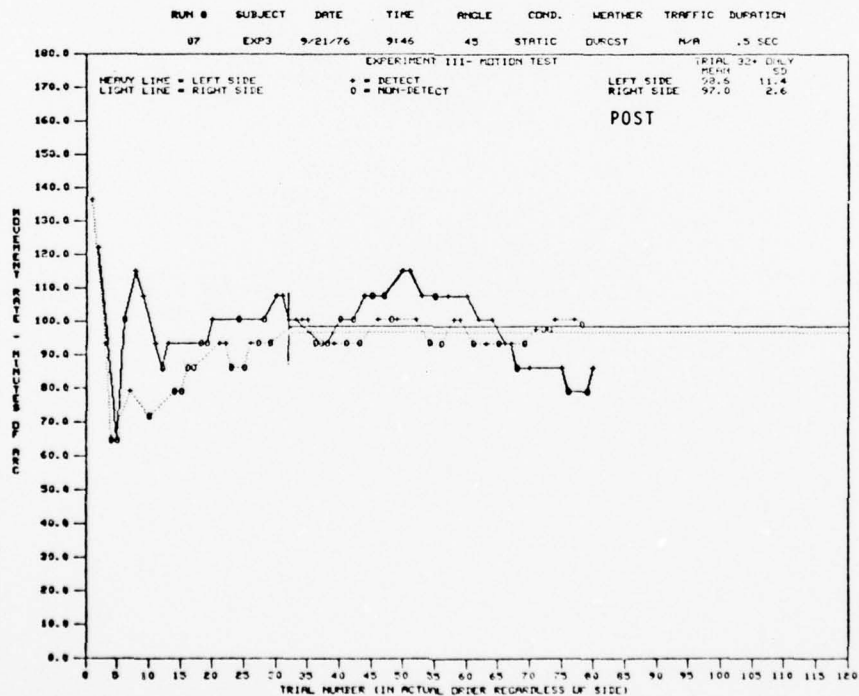
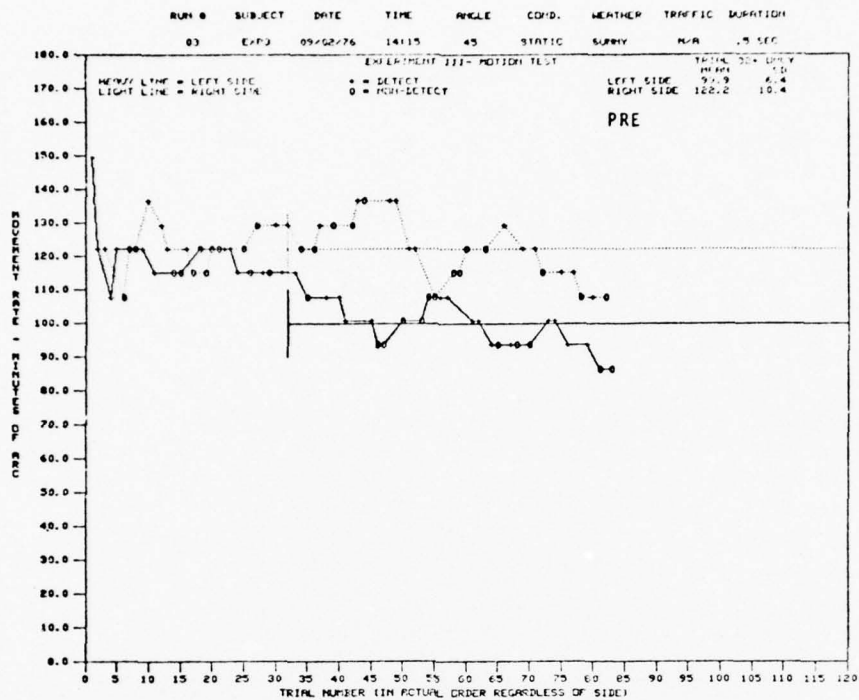

Figure B-11. Motion detection performance for pretesting (upper graph) and posttesting (lower graph). Mean thresholds are indicated by horizontal straight lines.

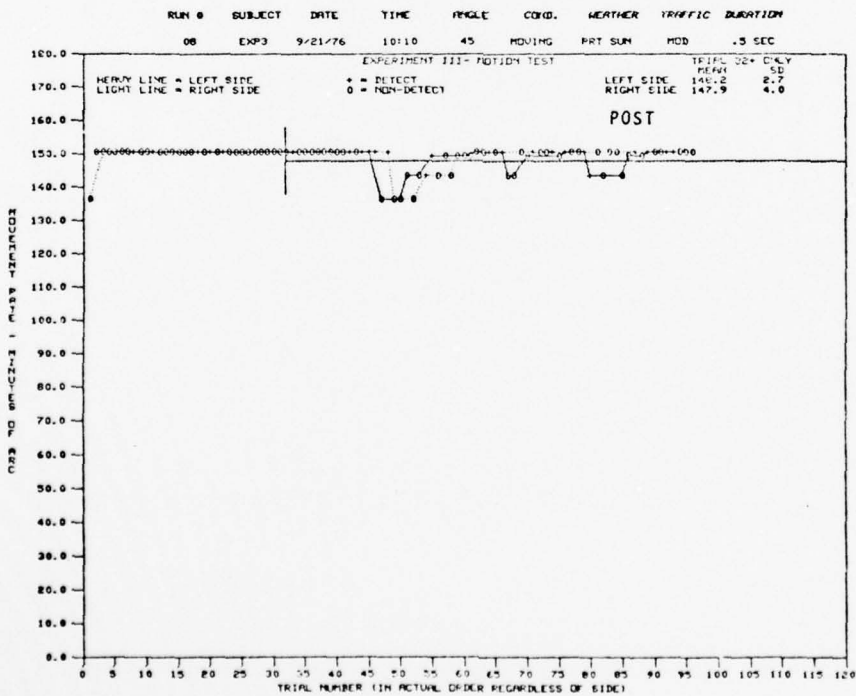
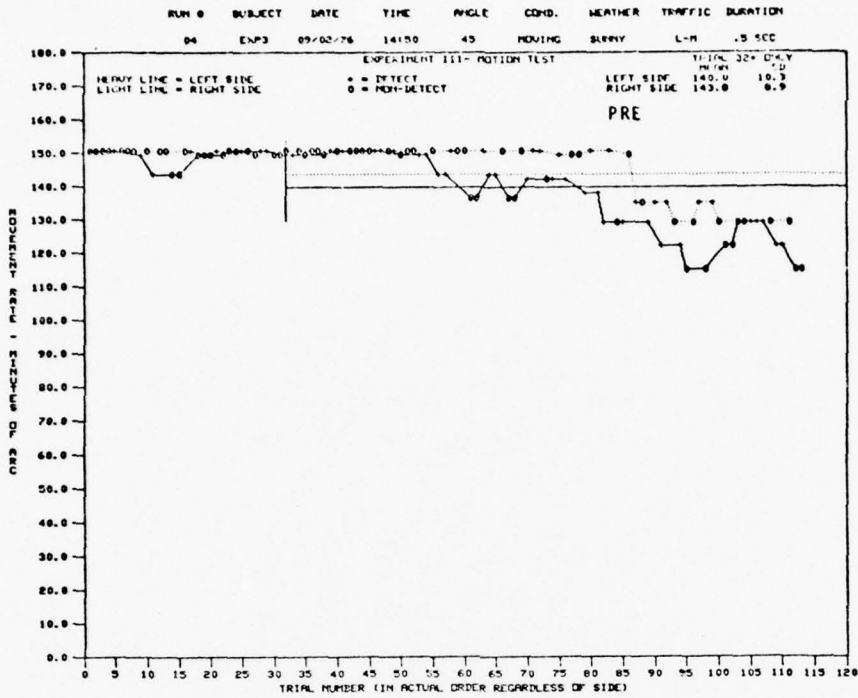

Figure B-12. Motion detection performance for pretesting (upper graph) and posttesting (lower graph). Mean thresholds are indicated by horizontal straight lines.

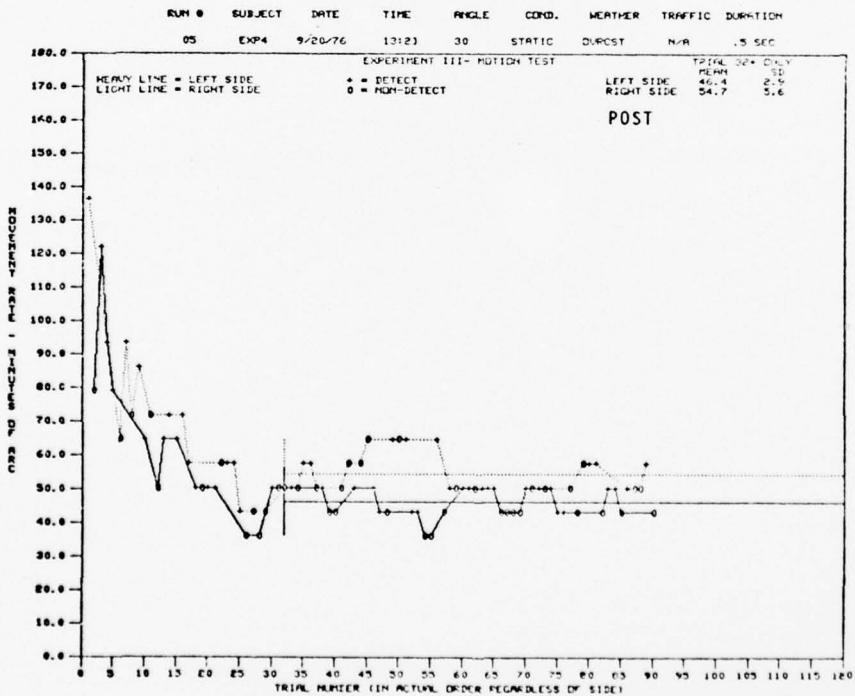
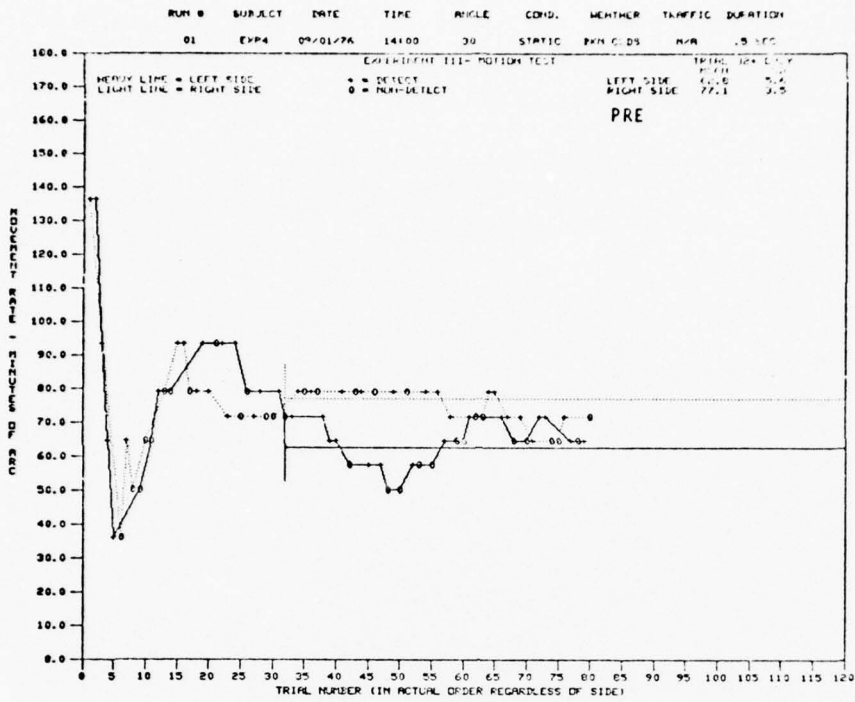

Figure B-13. Motion detection performance for pretesting (upper graph) and posttesting (lower graph). Mean thresholds are indicated by horizontal straight lines.

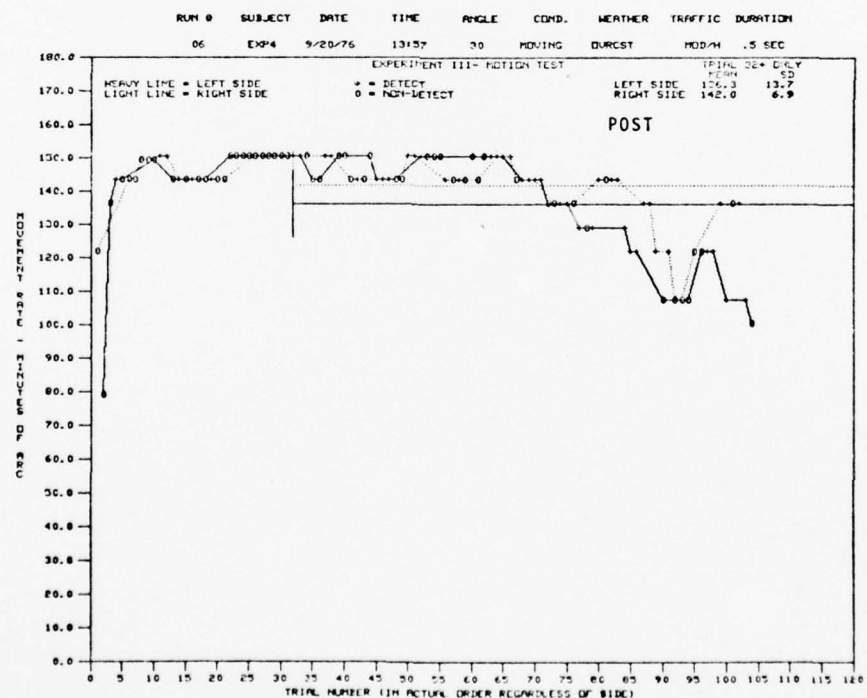
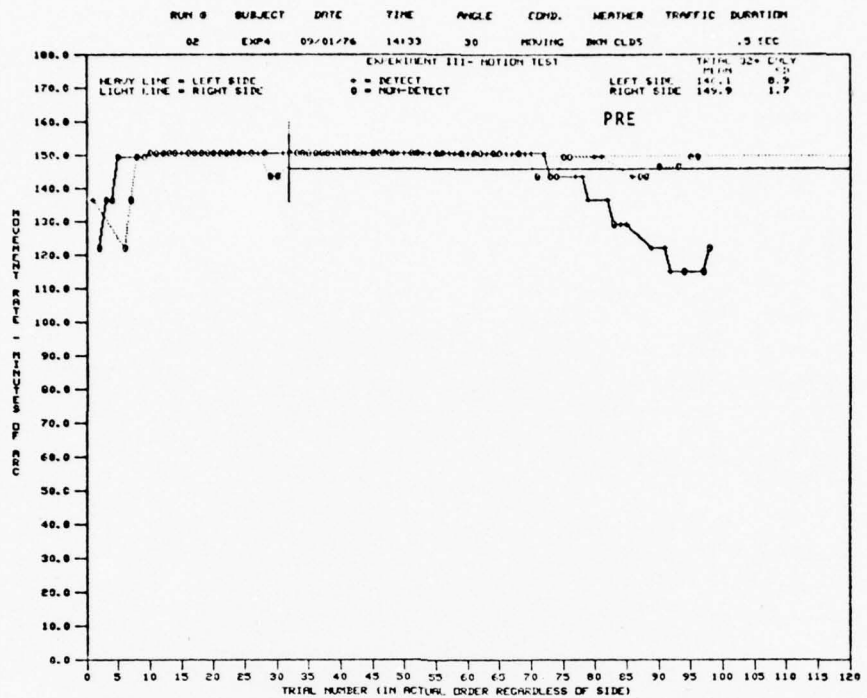

Figure B-14. Motion detection performance for pretesting (upper graph) and posttesting (lower graph). Mean thresholds are indicated by horizontal straight lines.

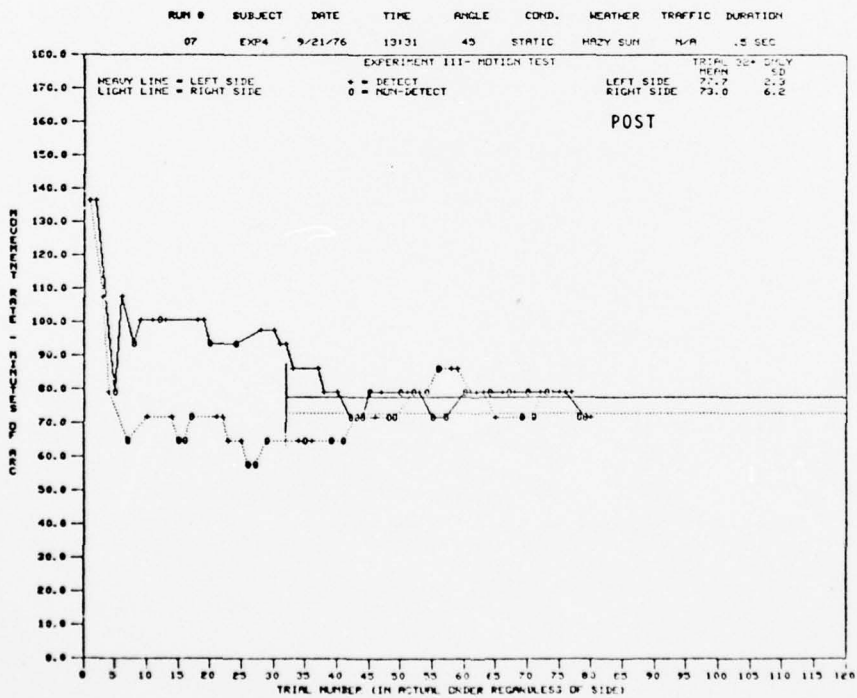
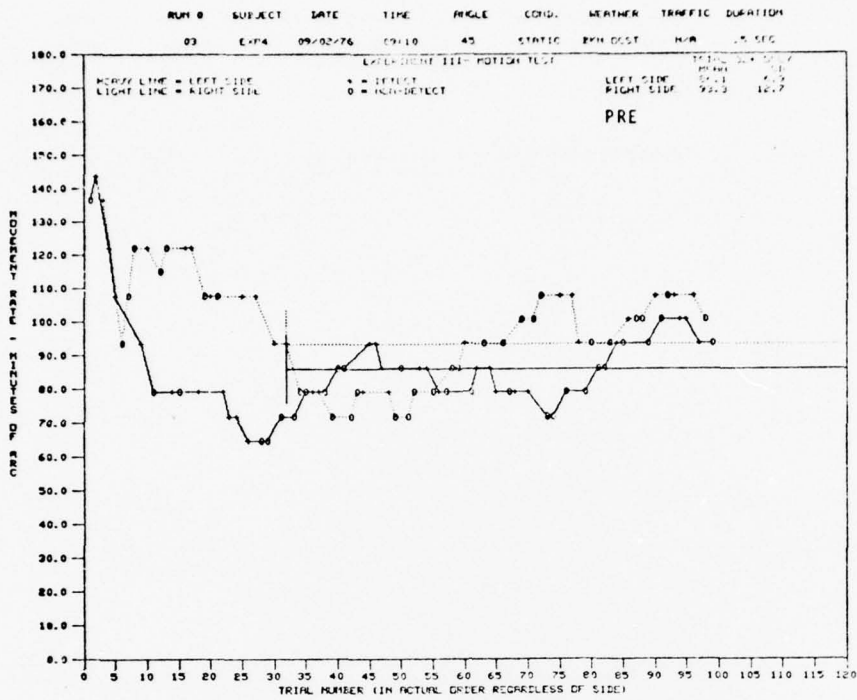

Figure B-15. Motion detection performance for pretesting (upper graph) and posttesting (lower graph). Mean thresholds are indicated by horizontal straight lines.

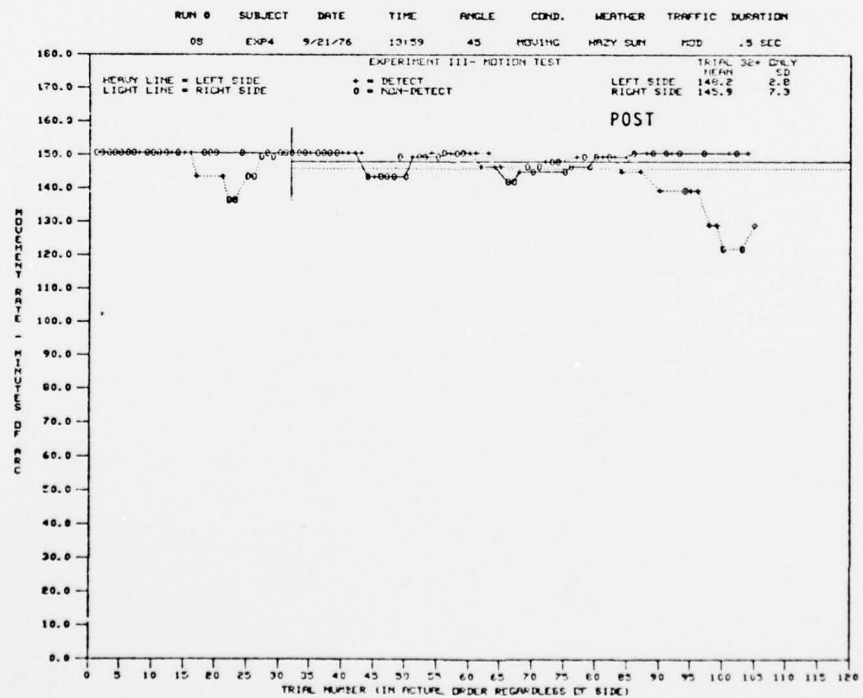
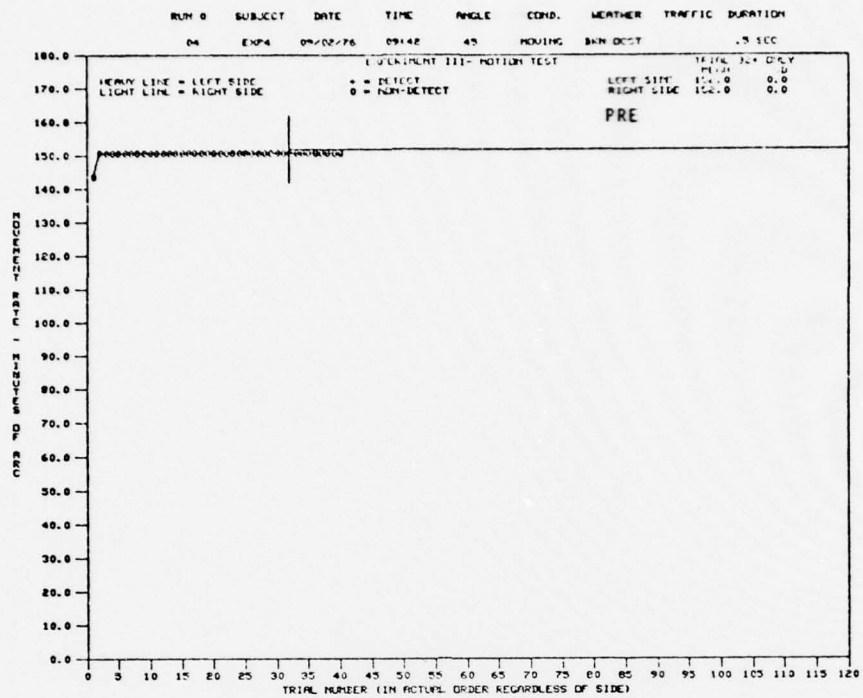

Figure B-16. Motion detection performance for pretesting (upper graph) and posttesting (lower graph). Mean thresholds are indicated by horizontal straight lines.

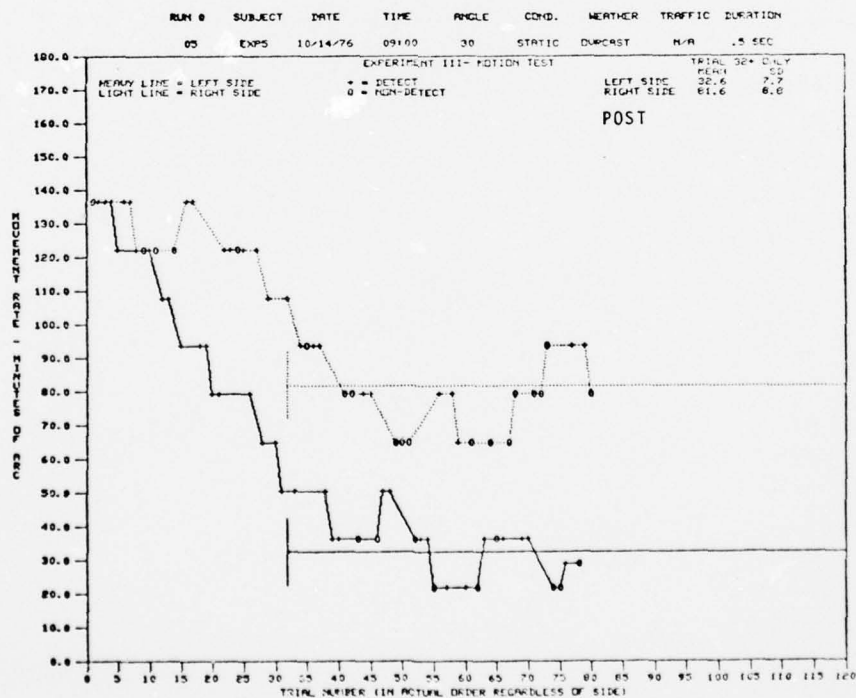
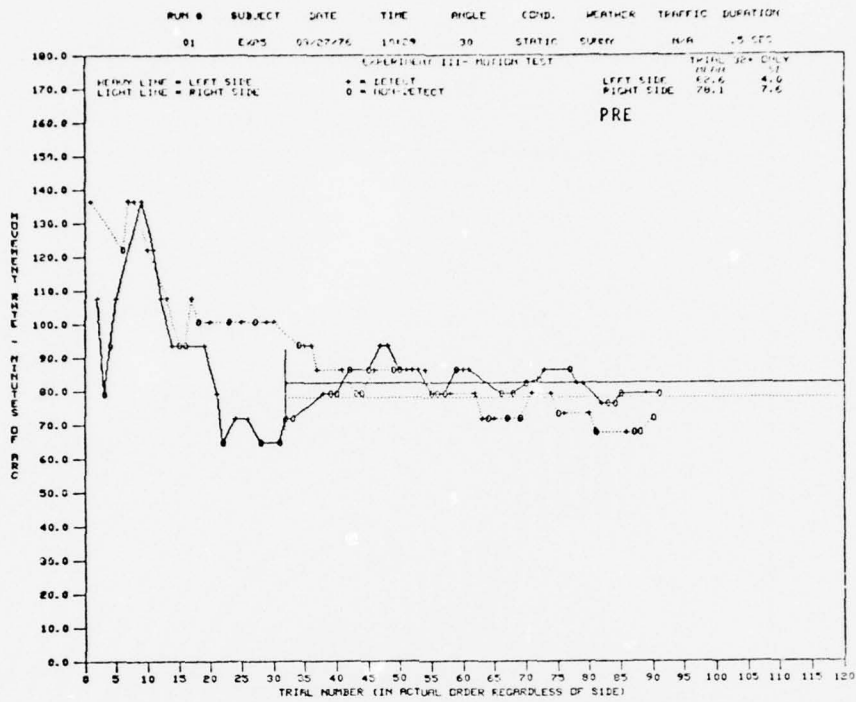

Figure B-17. Motion detection performance for pretesting (upper graph) and posttesting (lower graph). Mean thresholds are indicated by horizontal straight lines.

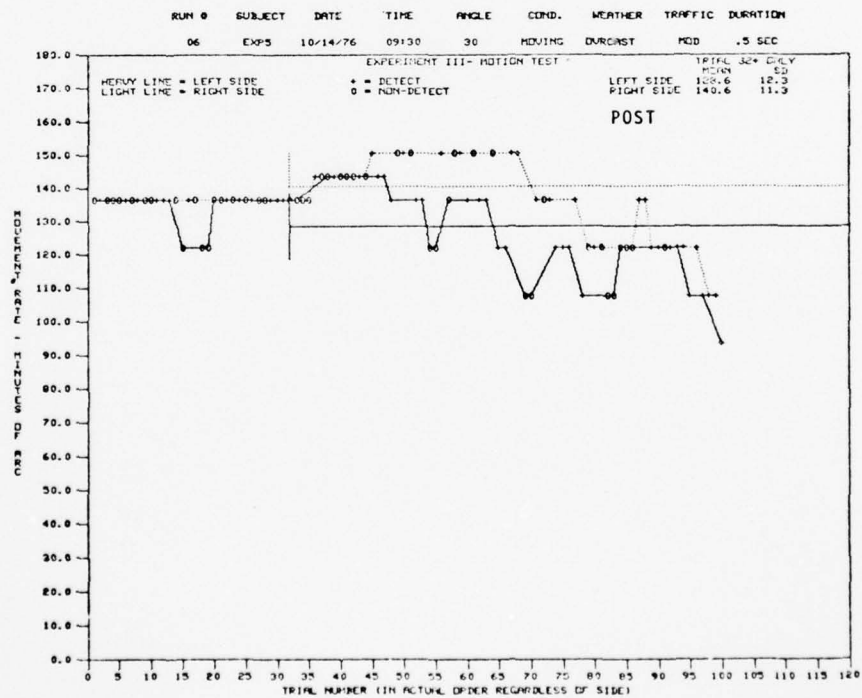
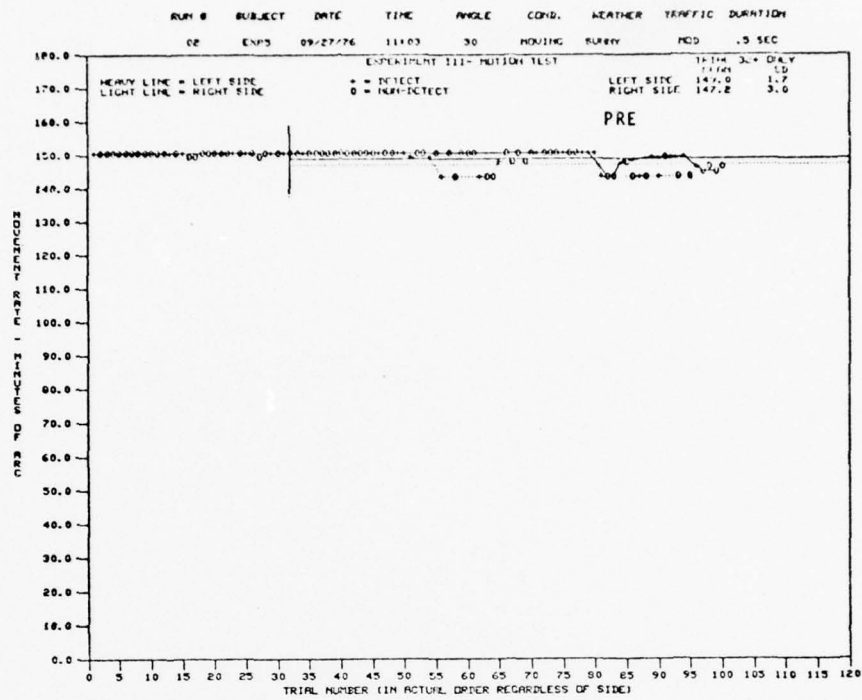

Figure B-18. Motion detection performance for pretesting (upper graph) and posttesting (lower graph). Mean thresholds are indicated by horizontal straight lines.

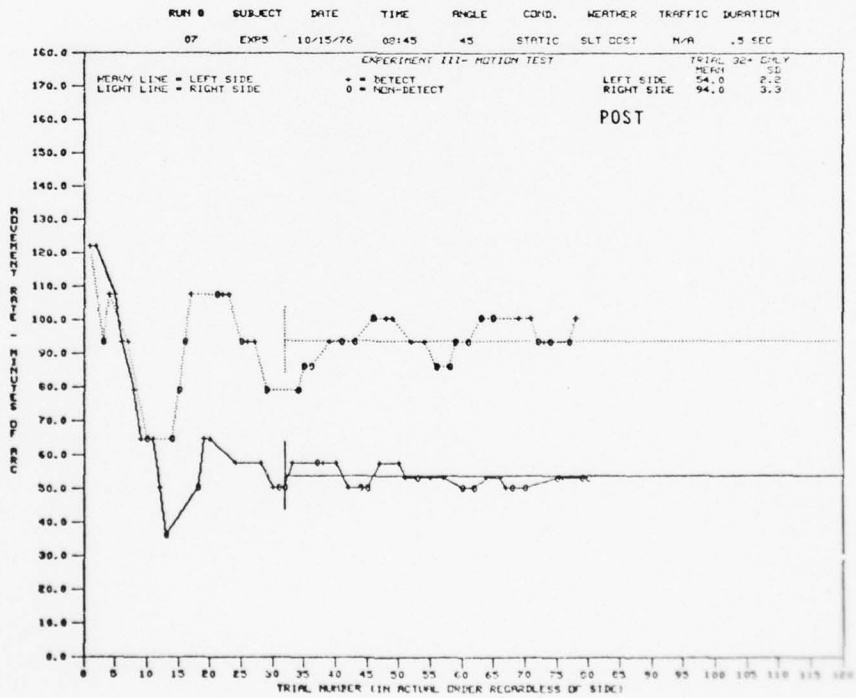
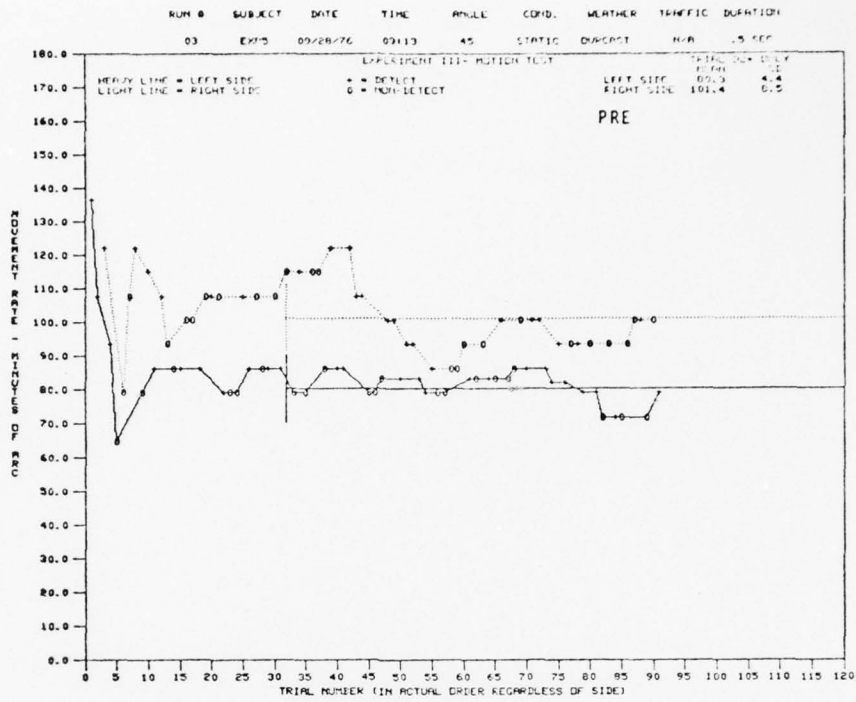

Figure B-19. Motion detection performance for pretesting (upper graph) and posttesting (lower graph). Mean thresholds are indicated by horizontal straight lines.

AD-A042 803

HUMAN FACTORS RESEARCH INC GOLETA CALIF
PERIPHERAL VISION TRAINING FOR MOTOR VEHICLE DRIVERS.(U)
JUN 77 R T HENNESSY, R E NEWTON
1767-F

F/G 5/9

DOT-HS-5-01204

UNCLASSIFIED

NL

3 of 3
ADA042803



END
DATE
FILMED
9-77
DDC

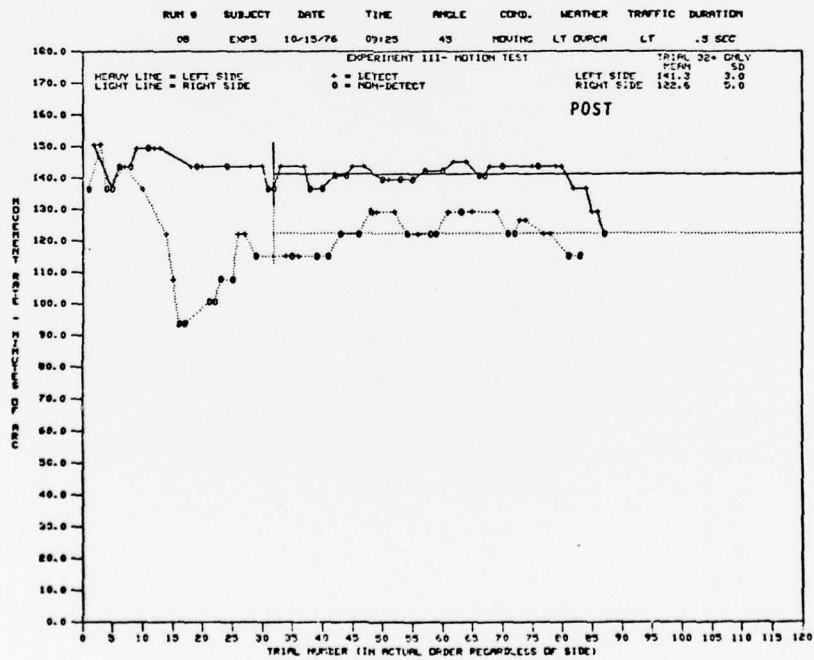
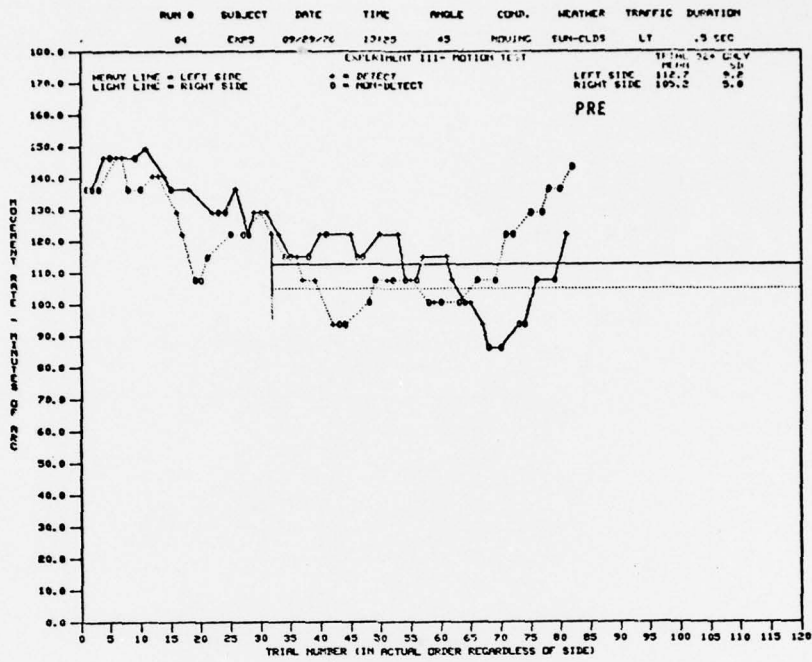

Figure B-20. Motion detection performance for pretesting (upper graph) and posttesting (lower graph). Mean thresholds are indicated by horizontal straight lines.

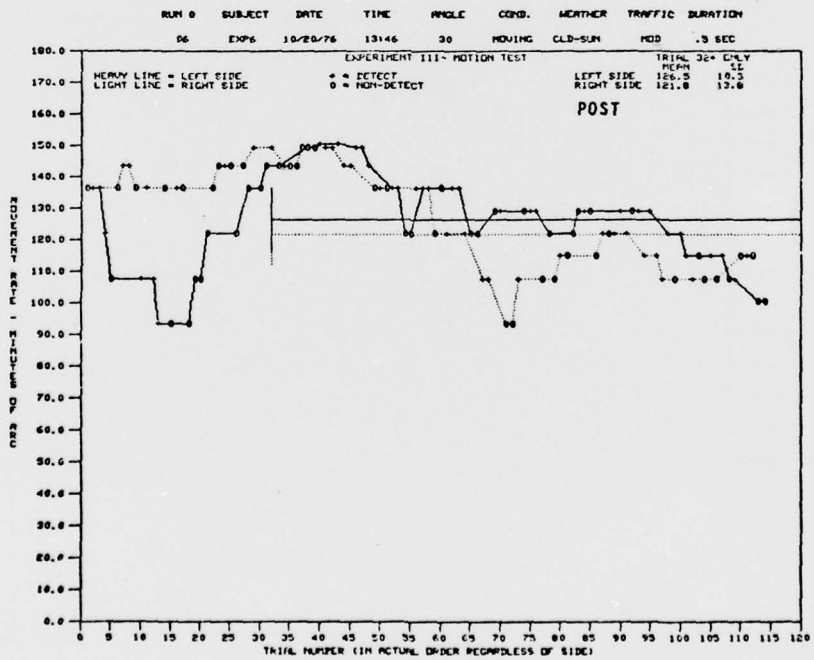
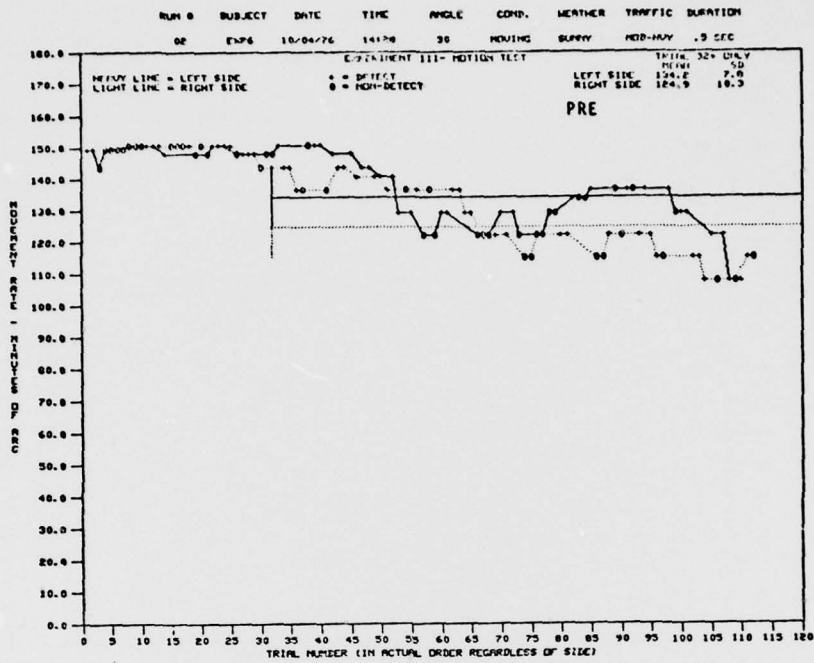

Figure B-22. Motion detection performance for pretesting (upper graph) and posttesting (lower graph). Mean thresholds are indicated by horizontal straight lines.

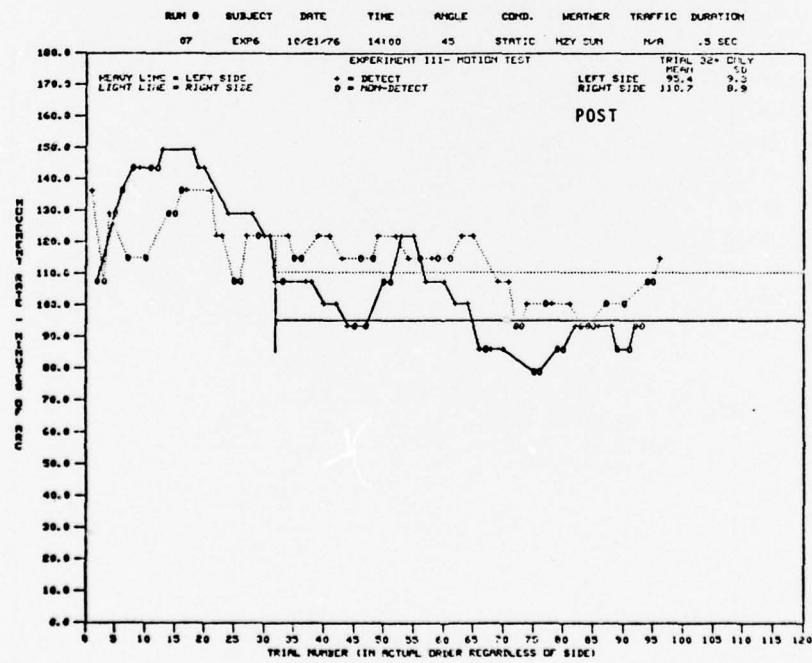
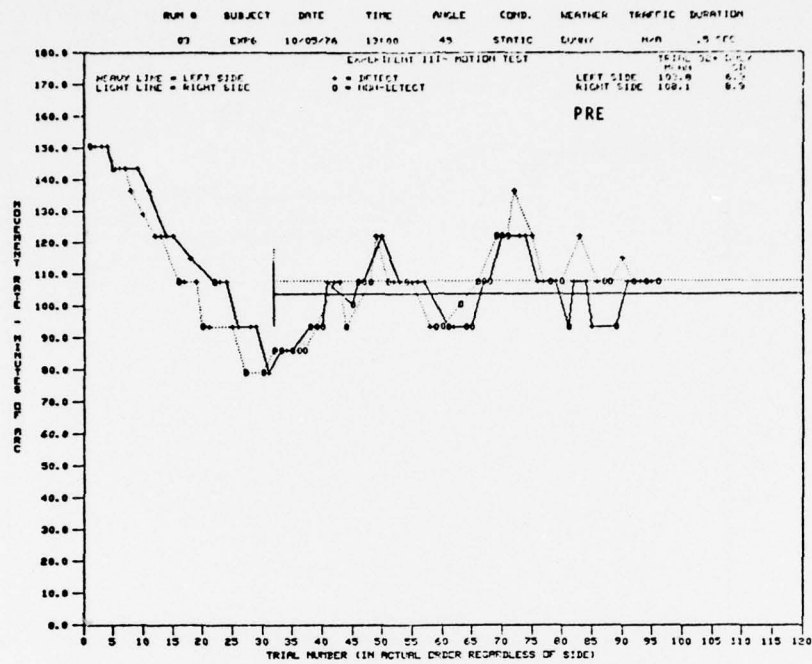

Figure B-23. Motion detection performance for pretesting (upper graph) and posttesting (lower graph). Mean thresholds are indicated by horizontal straight lines.

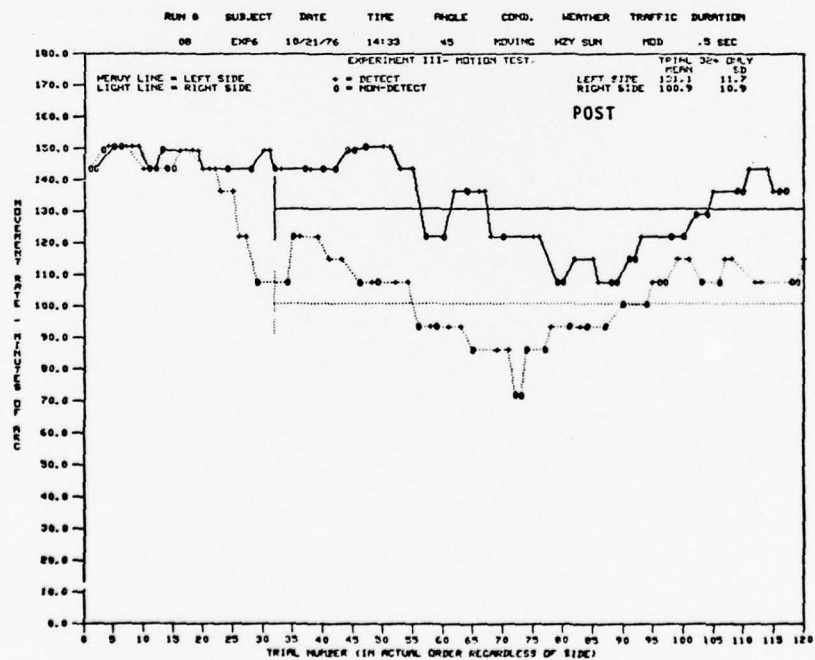
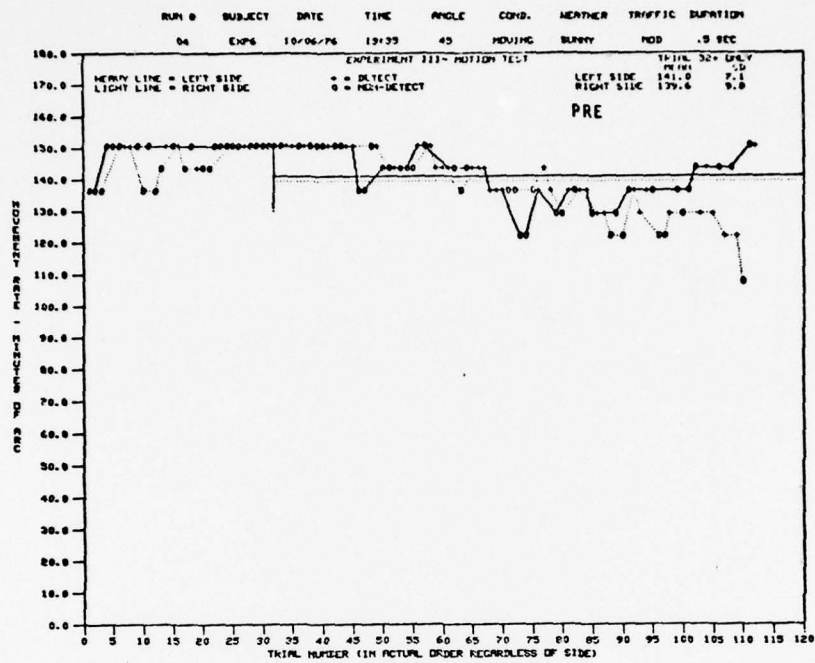

Figure B-24. Motion detection performance for pretesting (upper graph) and posttesting (lower graph). Mean thresholds are indicated by horizontal straight lines.

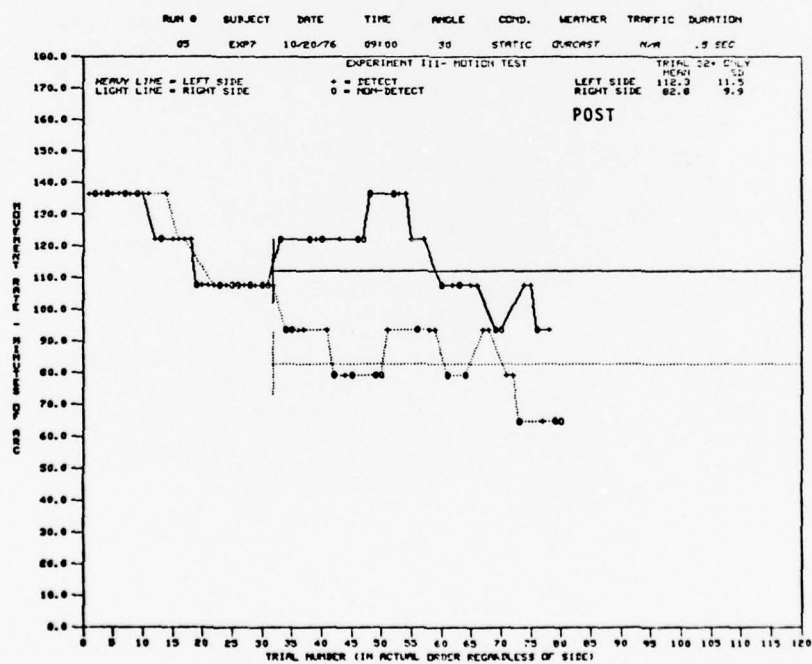
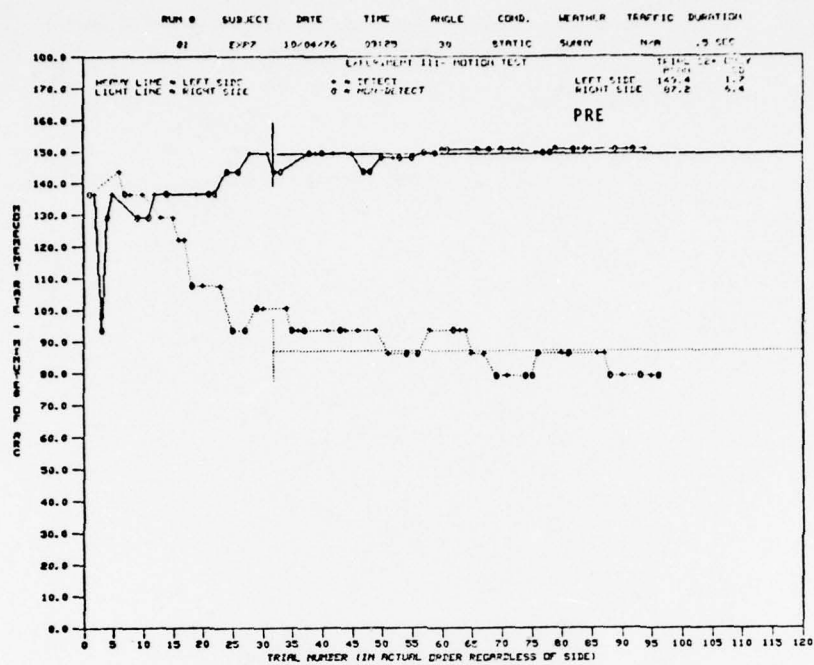

Figure B-25. Motion detection performance for pretesting (upper graph) and posttesting (lower graph). Mean thresholds are indicated by horizontal straight lines.

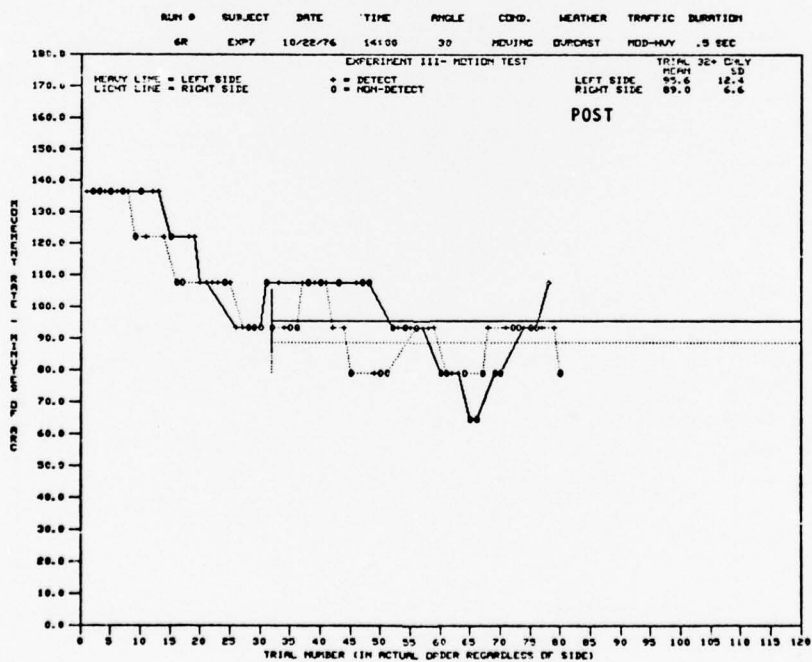
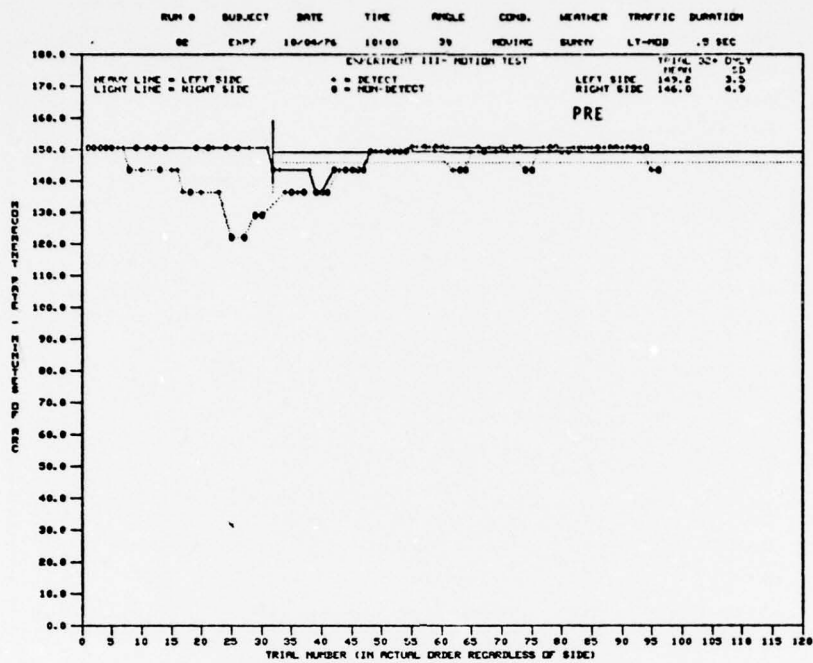

Figure B-26. Motion detection performance for pretesting (upper graph) and posttesting (lower graph). Mean thresholds are indicated by horizontal straight lines.

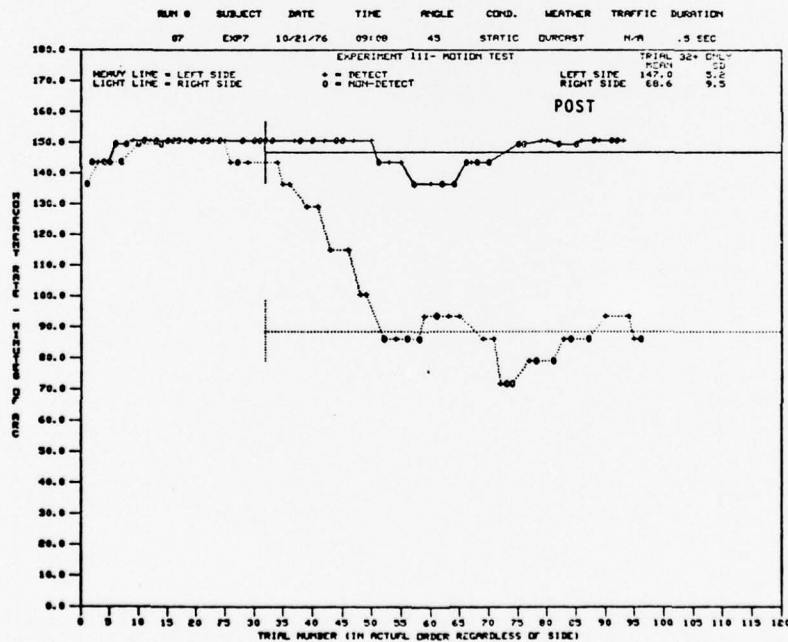
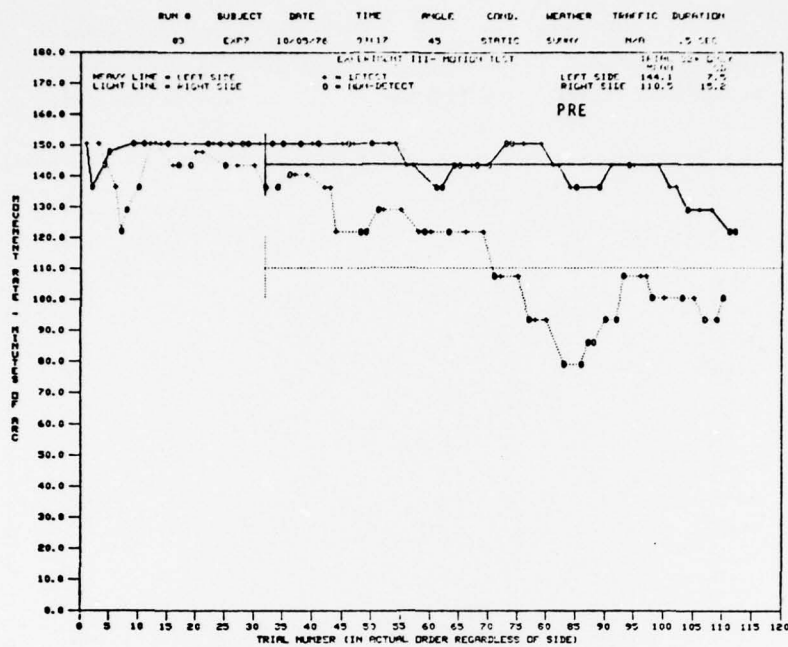

Figure B-27. Motion detection performance for pretesting (upper graph) and posttesting (lower graph). Mean thresholds are indicated by horizontal straight lines.

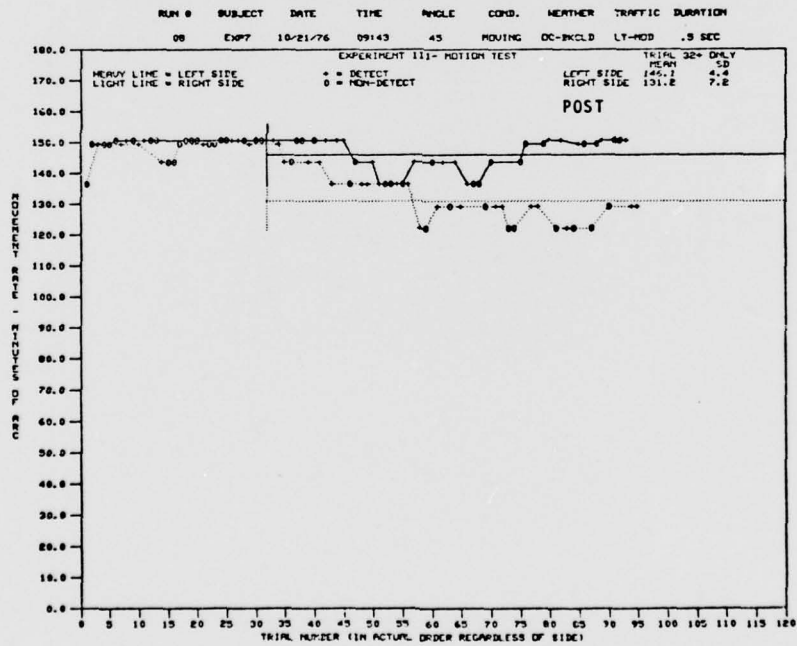
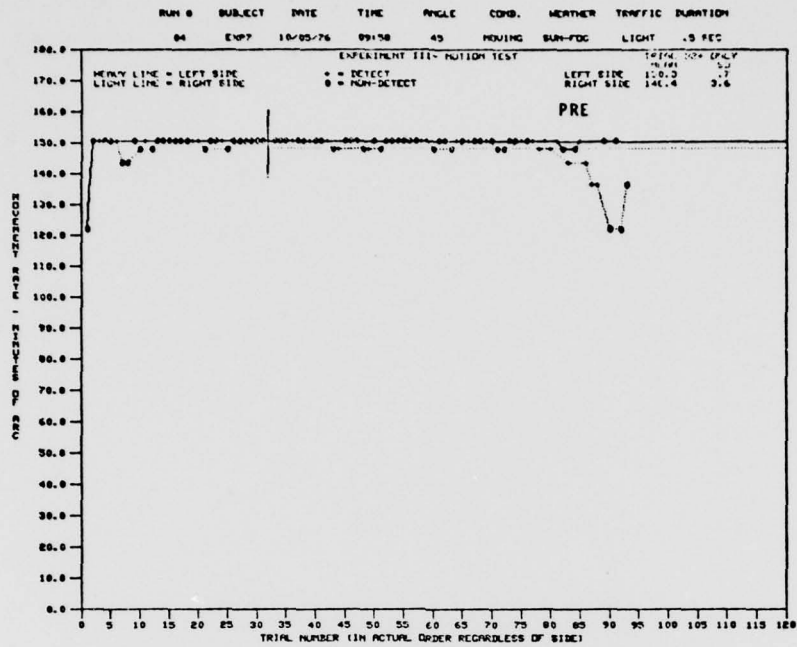

Figure B-28. Motion detection performance for pretesting (upper graph) and posttesting (lower graph). Mean thresholds are indicated by horizontal straight lines.

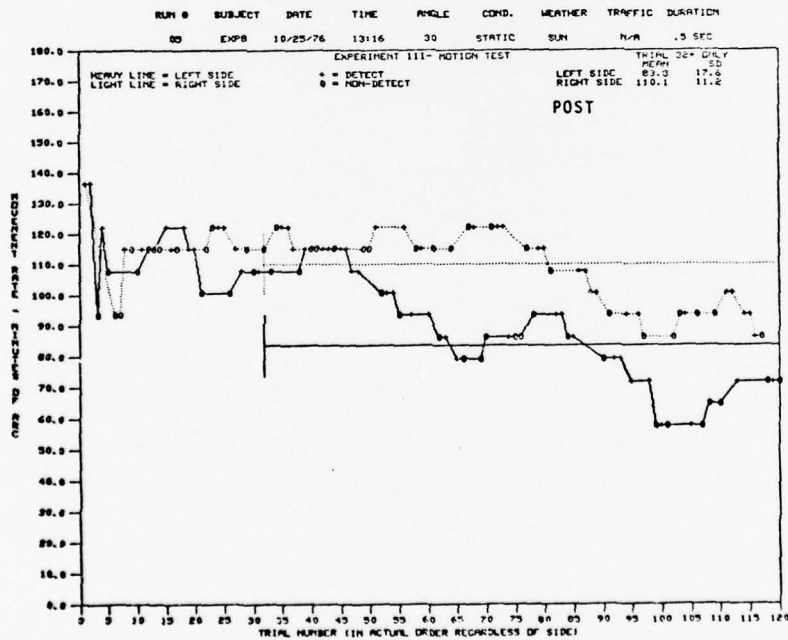
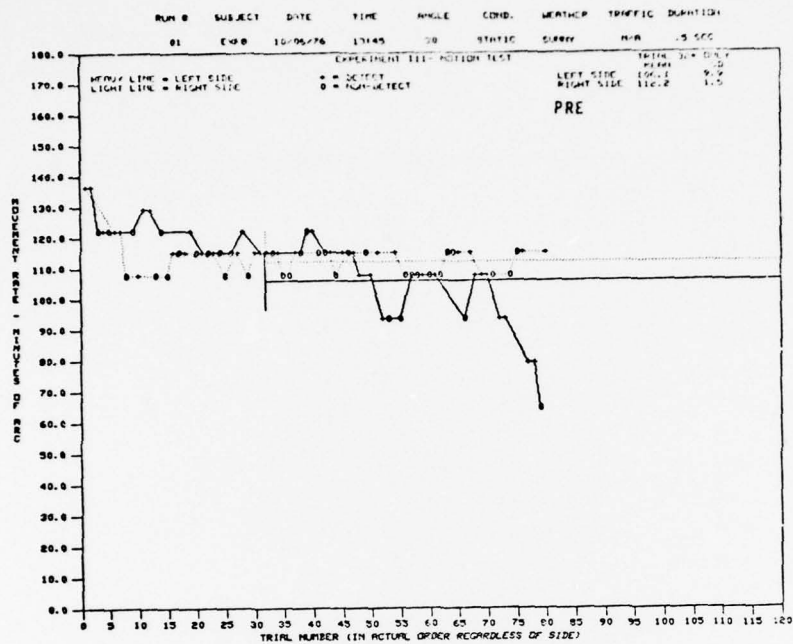

Figure B-29. Motion detection performance for pretesting (upper graph) and posttesting (lower graph). Mean thresholds are indicated by horizontal straight lines.

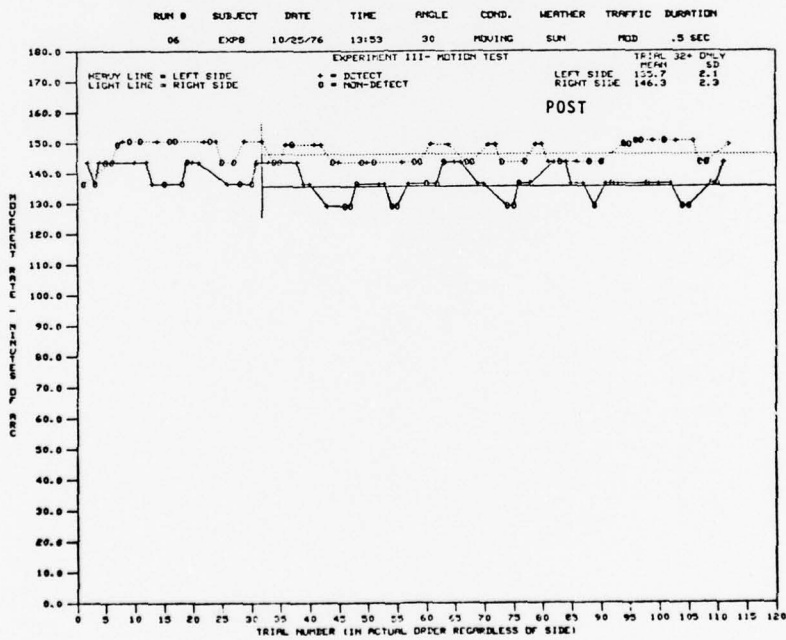
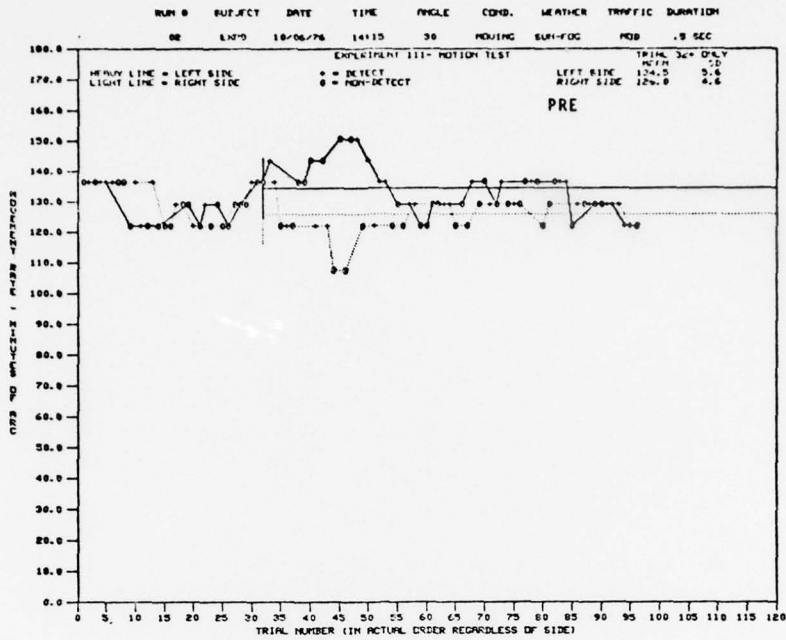

Figure B-30. Motion detection performance for pretesting (upper graph) and posttesting (lower graph). Mean thresholds are indicated by horizontal straight lines.

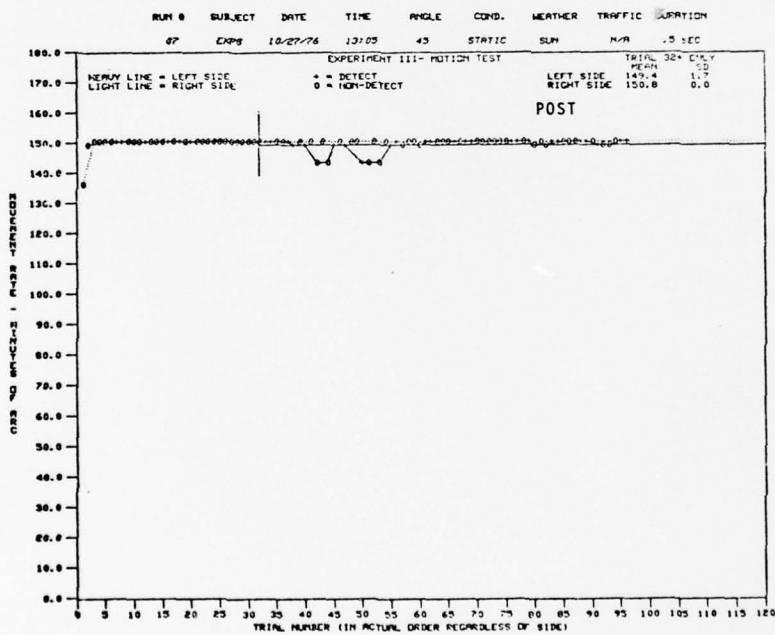
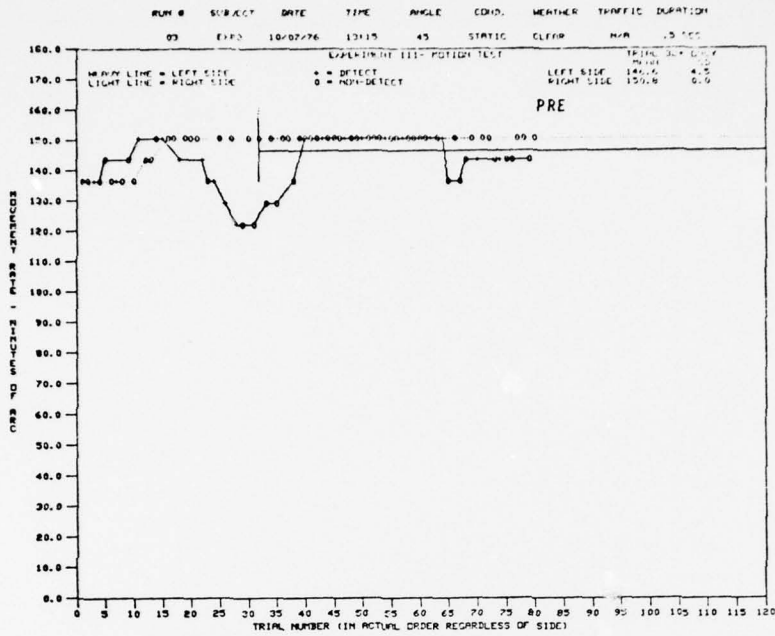

Figure B-31. Motion detection performance for pretesting (upper graph) and posttesting (lower graph). Mean thresholds are indicated by horizontal straight lines.

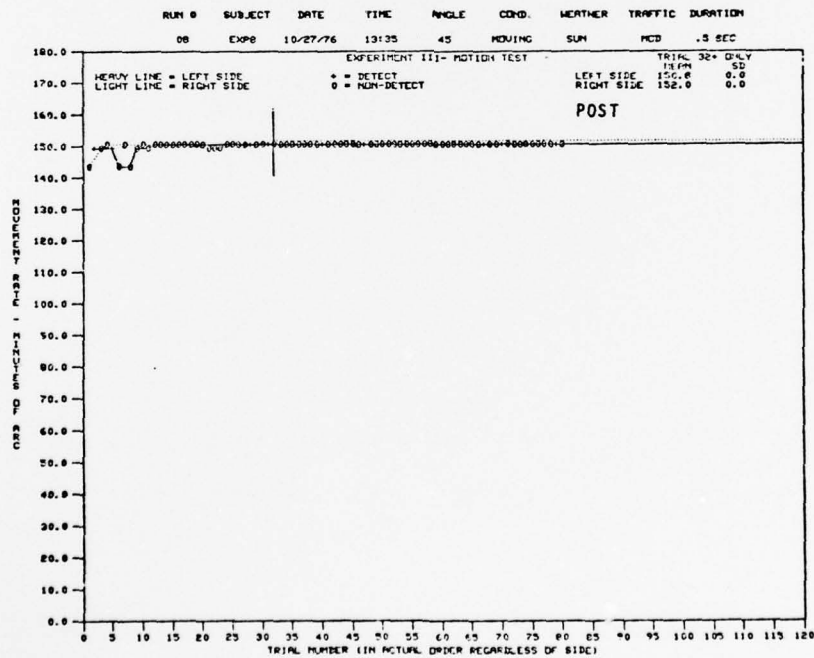
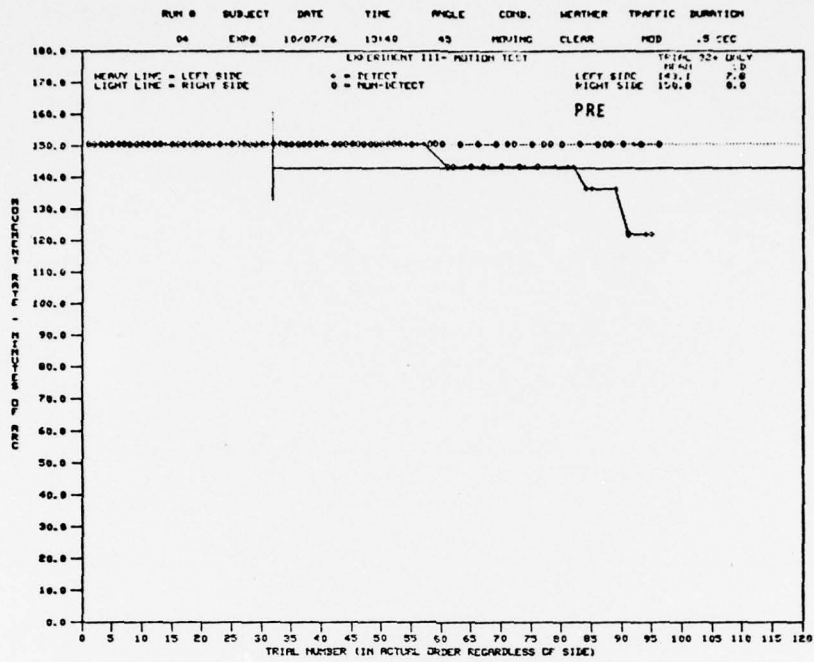

Figure B-32. Motion detection performance for pretesting (upper graph) and posttesting (lower graph). Mean thresholds are indicated by horizontal straight lines.

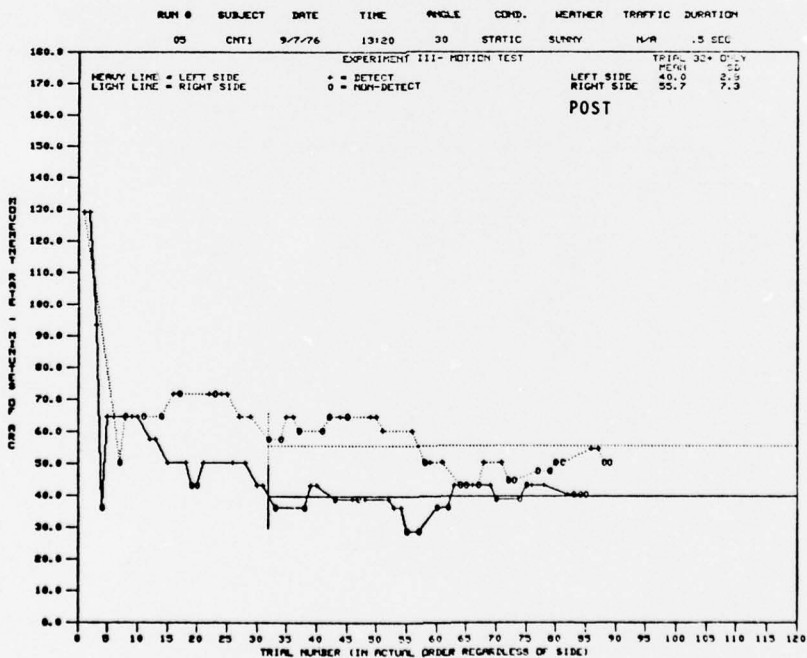
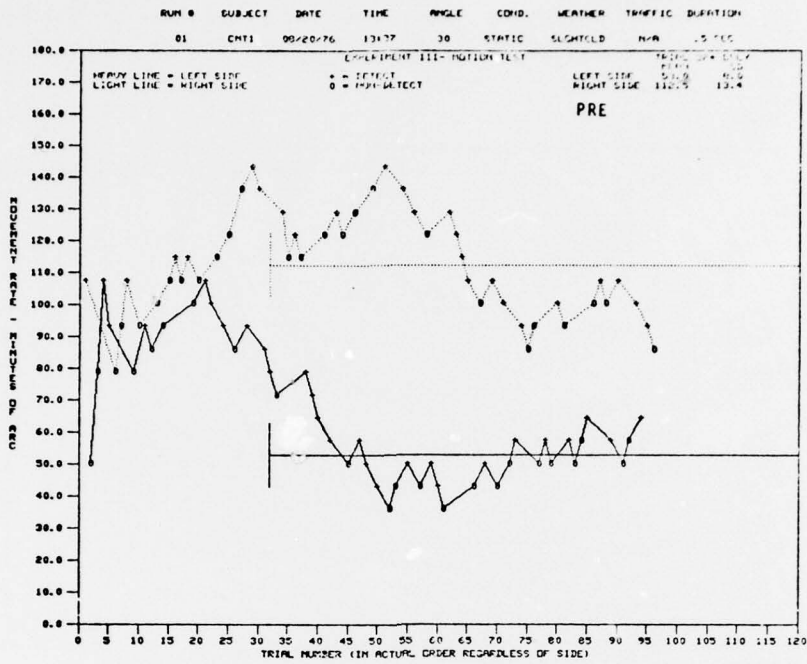

Figure B-33. Motion detection performance for pretesting (upper graph) and posttesting (lower graph). Mean thresholds are indicated by horizontal straight lines.

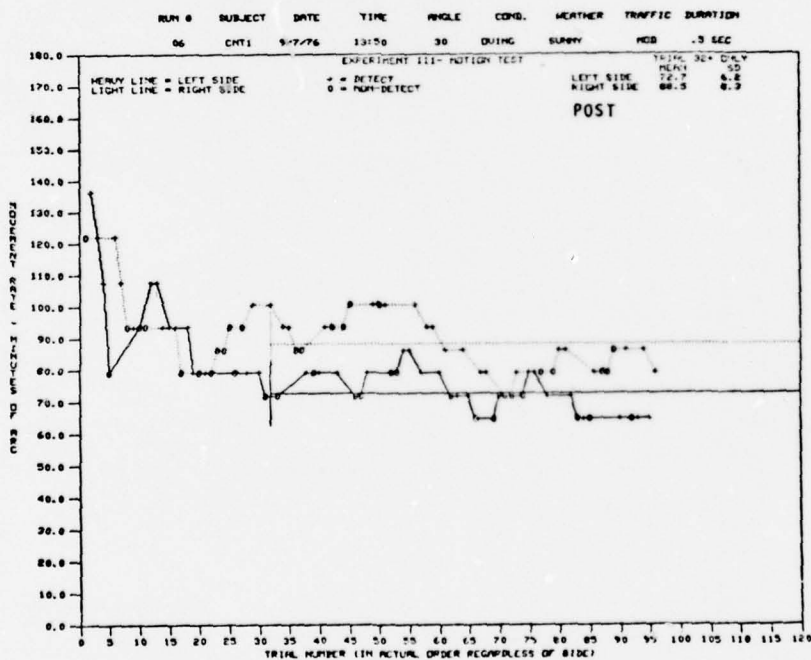
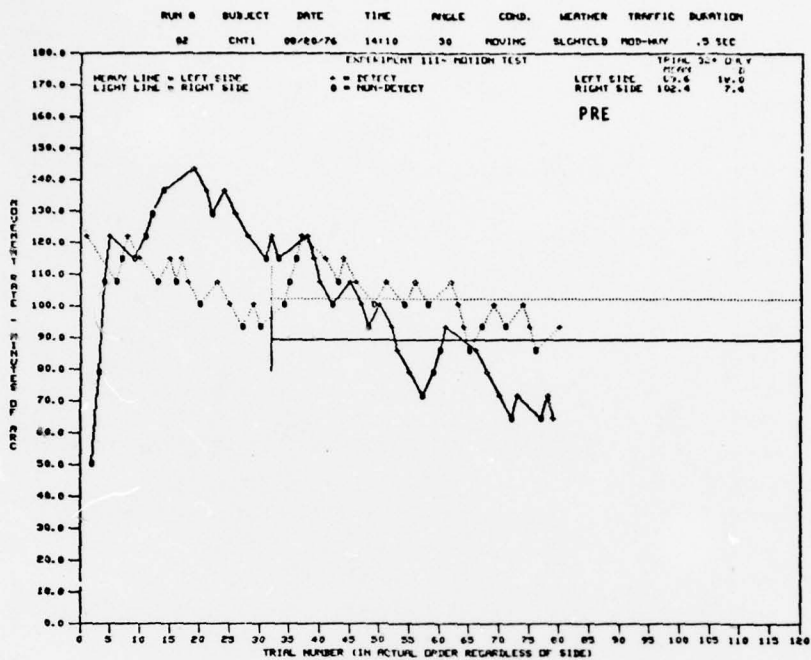

Figure B-34. Motion detection performance for pretesting (upper graph) and posttesting (lower graph). Mean thresholds are indicated by horizontal straight lines.

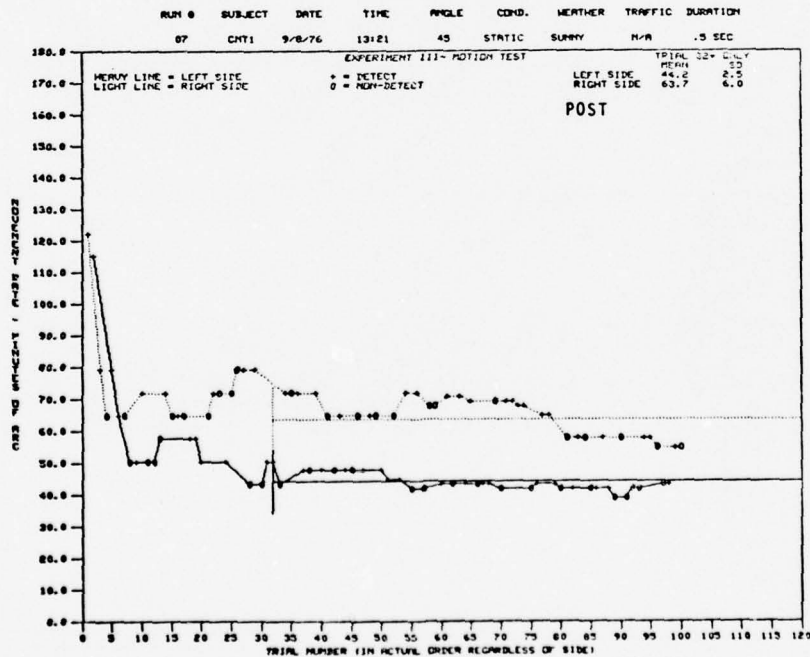
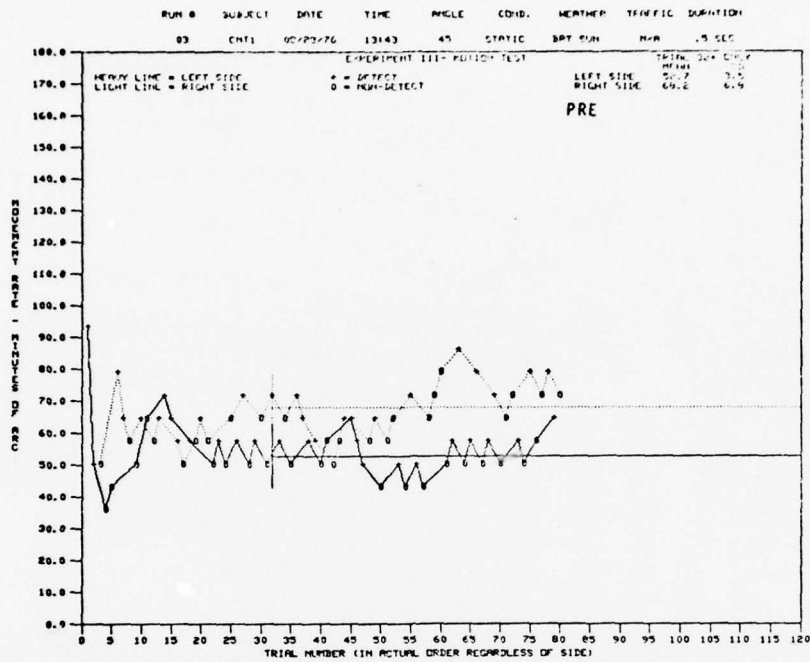

Figure B-35. Motion detection performance for pretesting (upper graph) and posttesting (lower graph). Mean thresholds are indicated by horizontal straight lines.

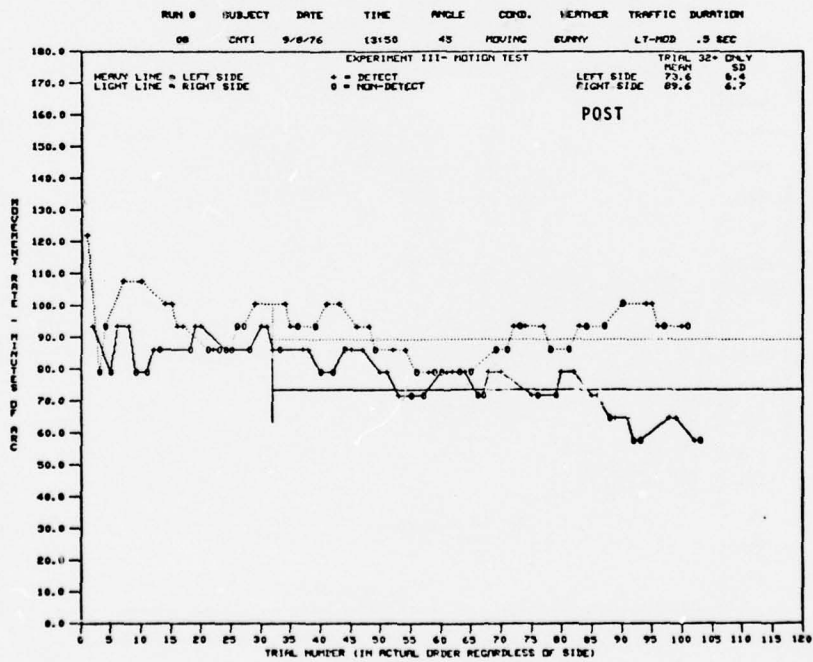
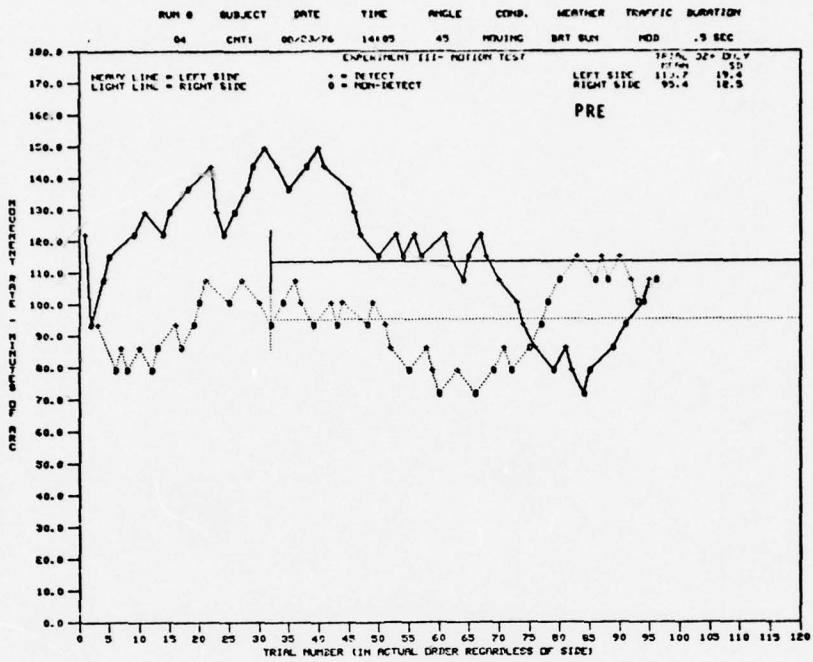

Figure B-36. Motion detection performance for pretesting (upper graph) and posttesting (lower graph). Mean thresholds are indicated by horizontal straight lines.

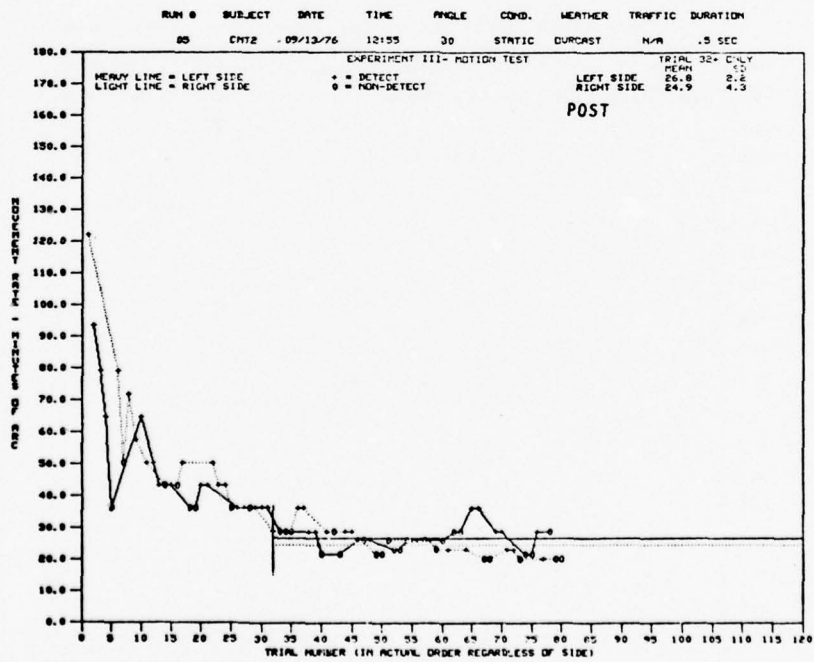
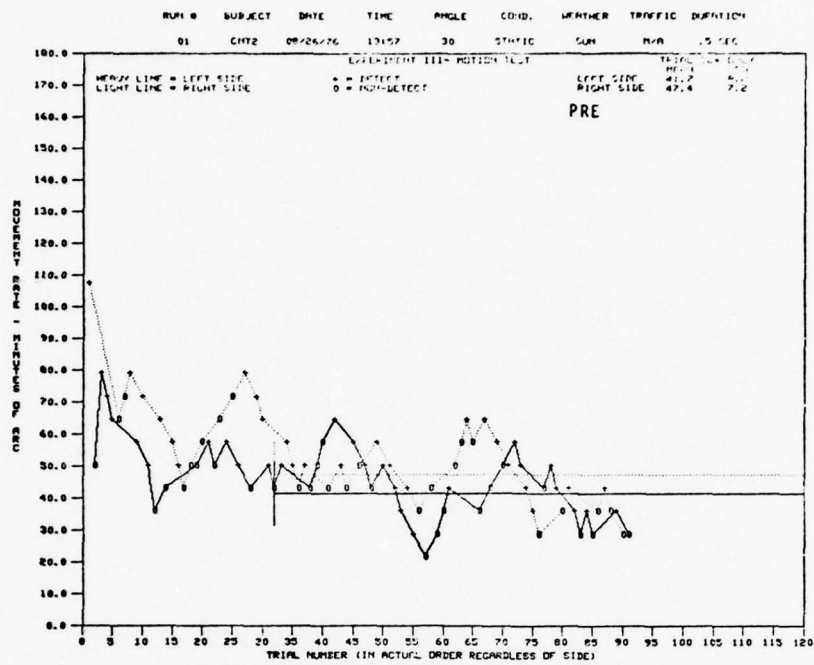

Figure B-37. Motion detection performance for pretesting (upper graph) and posttesting (lower graph). Mean thresholds are indicated by horizontal straight lines.

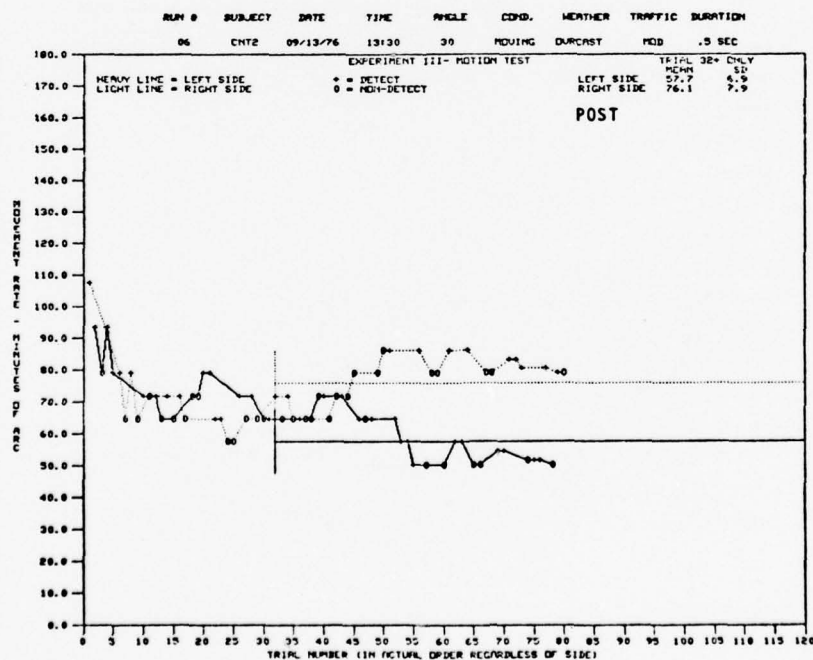
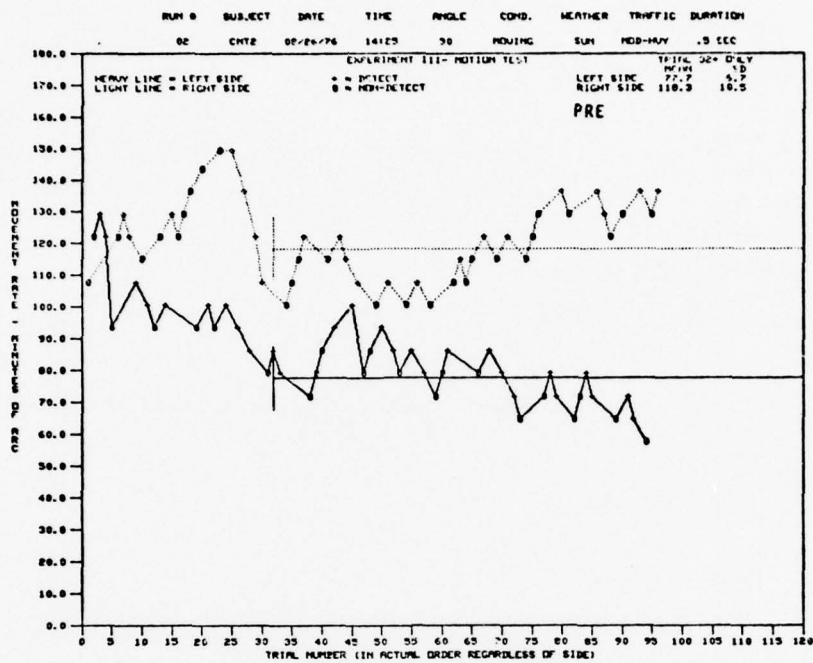

Figure B-38. Motion detection performance for pretesting (upper graph) and posttesting (lower graph). Mean thresholds are indicated by horizontal straight lines.

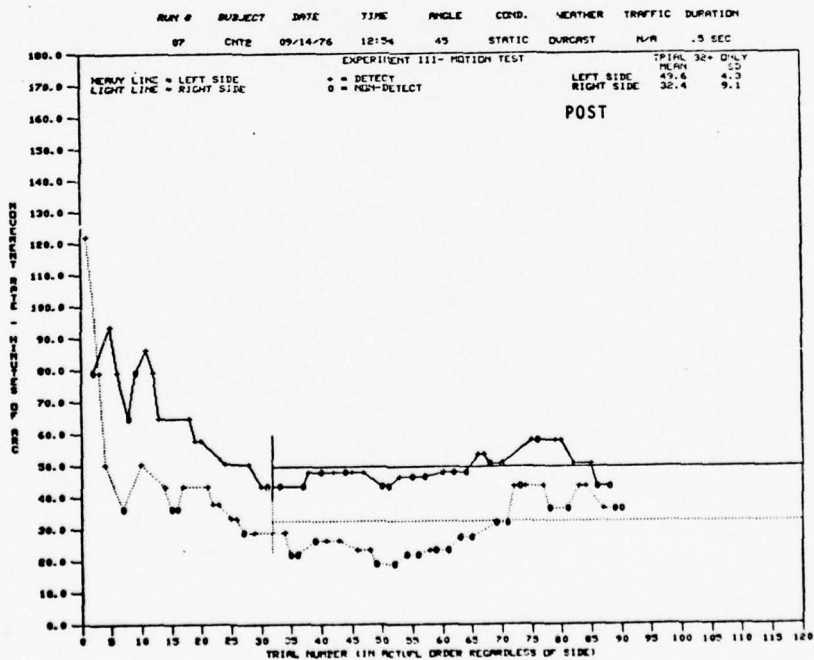
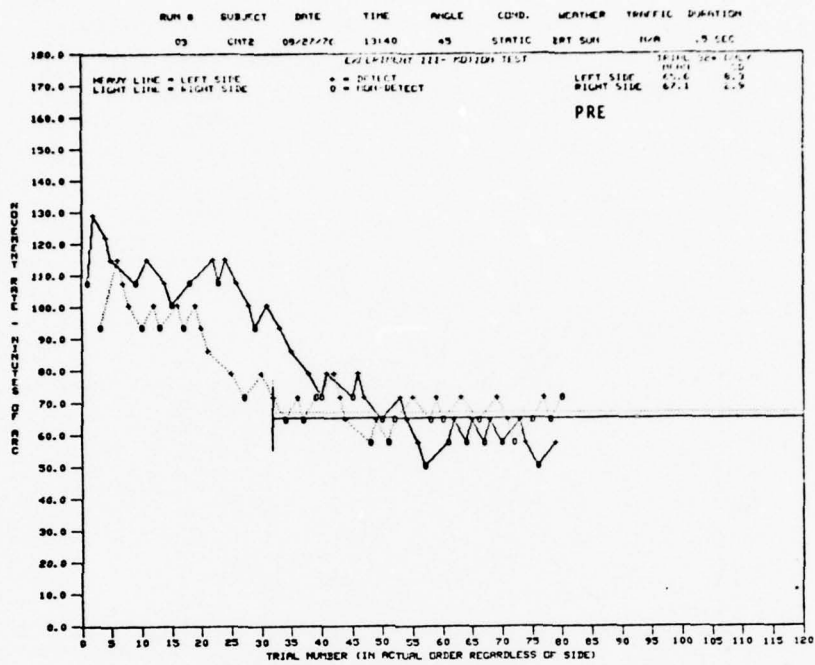

Figure B-39. Motion detection performance for pretesting (upper graph) and posttesting (lower graph). Mean thresholds are indicated by horizontal straight lines.

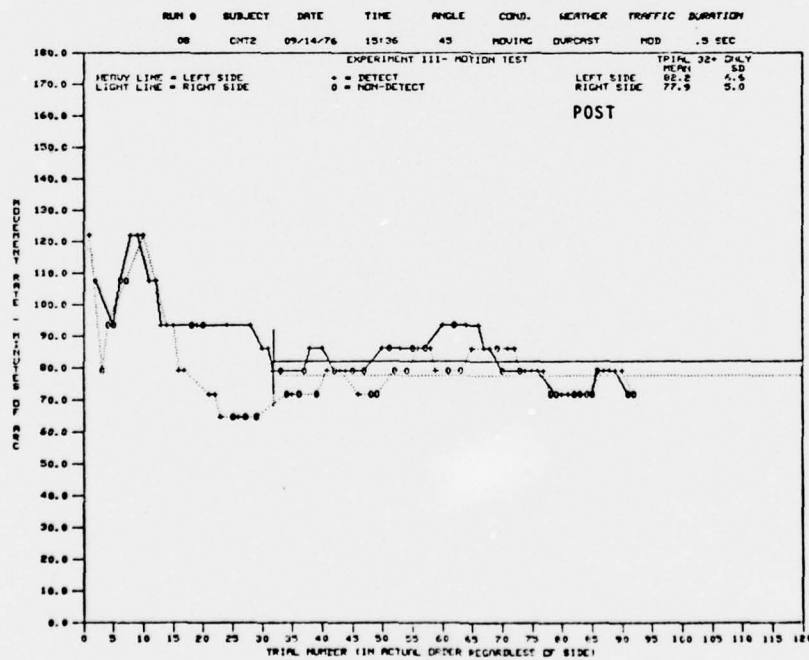
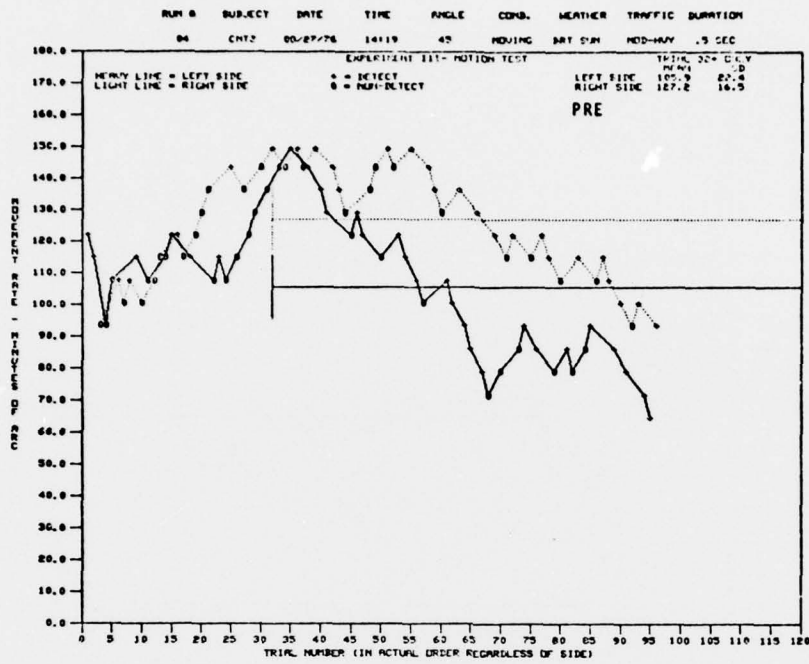

Figure B-40. Motion detection performance for pretesting (upper graph) and posttesting (lower graph). Mean thresholds are indicated by horizontal straight lines.

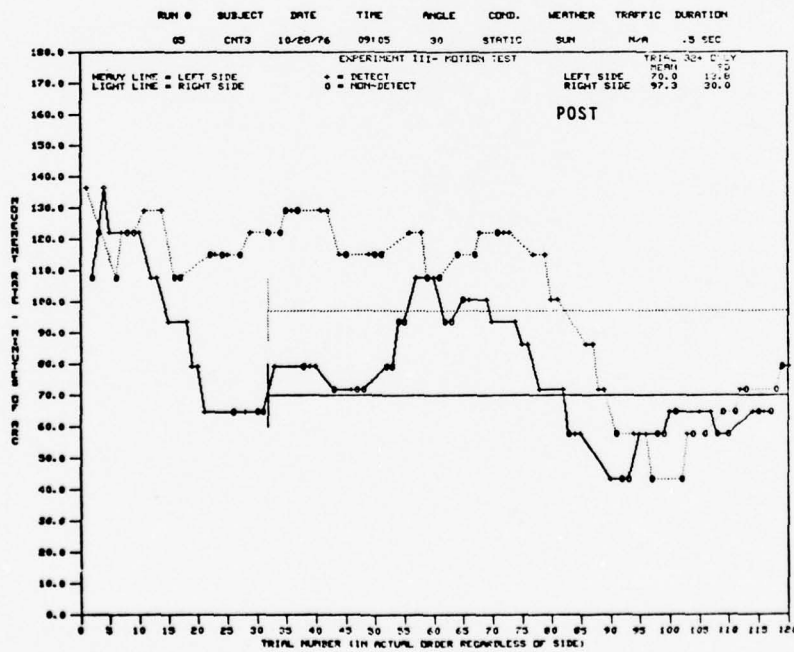
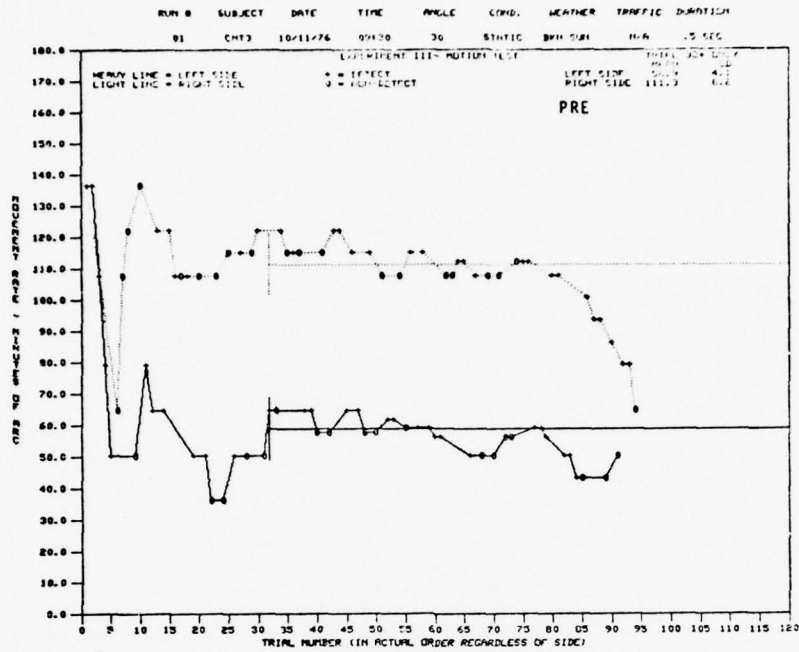

Figure B-41. Motion detection performance for pretesting (upper graph) and posttesting (lower graph). Mean thresholds are indicated by horizontal straight lines.

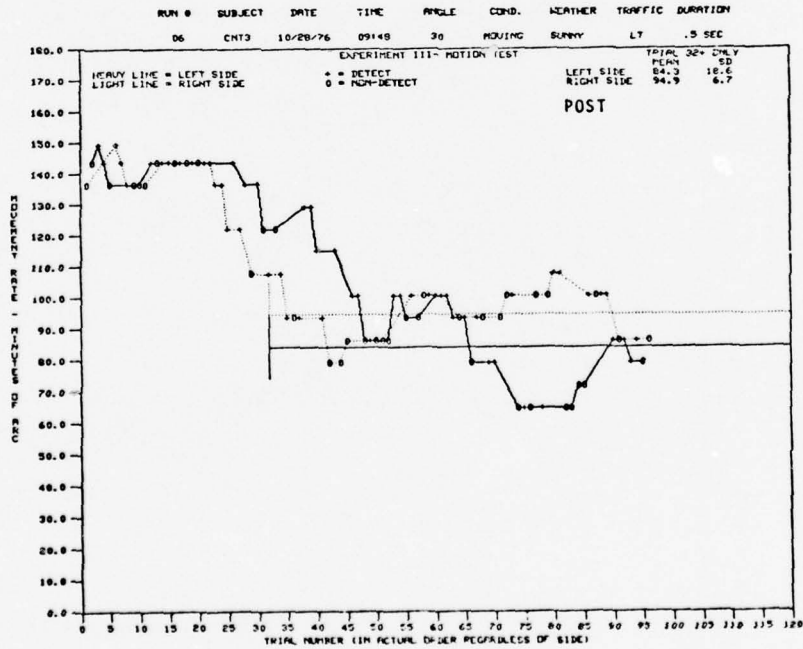
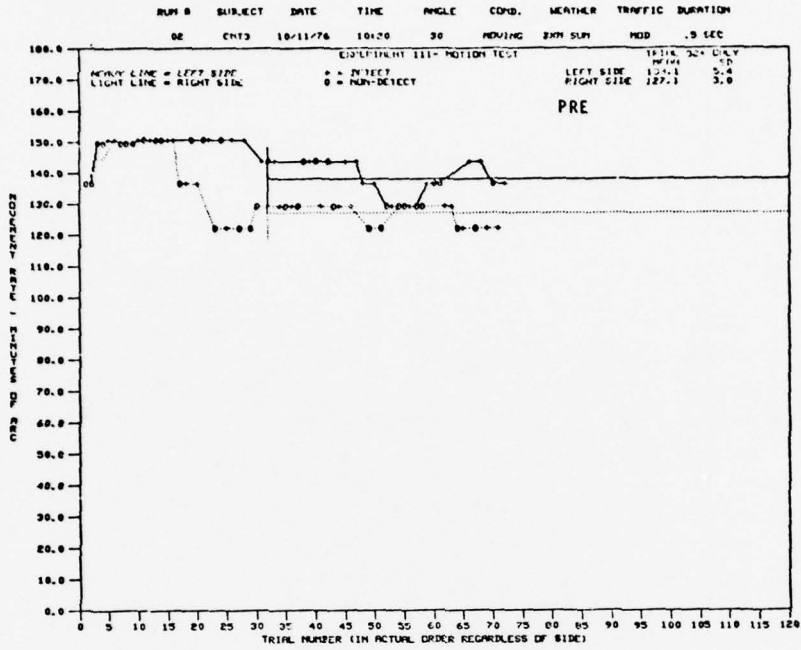

Figure B-42. Motion detection performance for pretesting (upper graph) and posttesting (lower graph). Mean thresholds are indicated by horizontal straight lines.

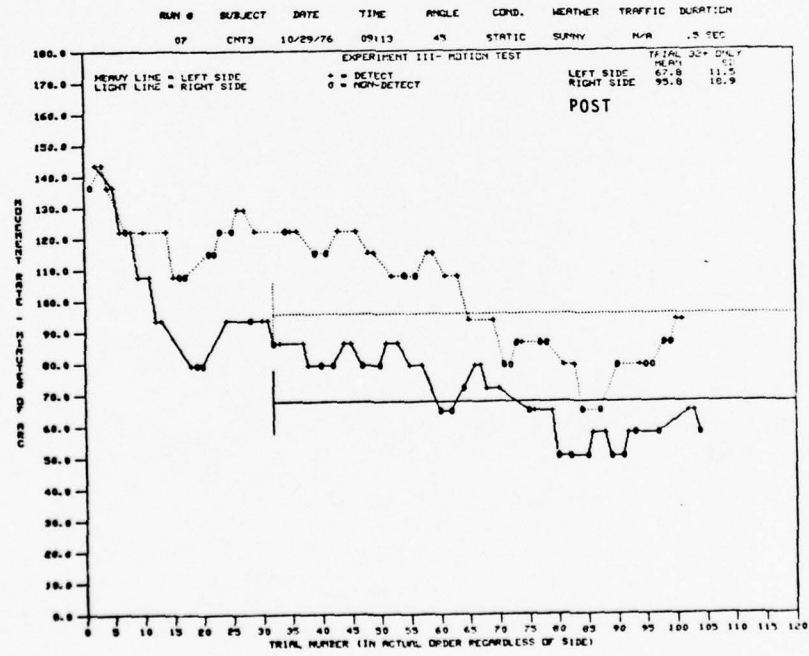
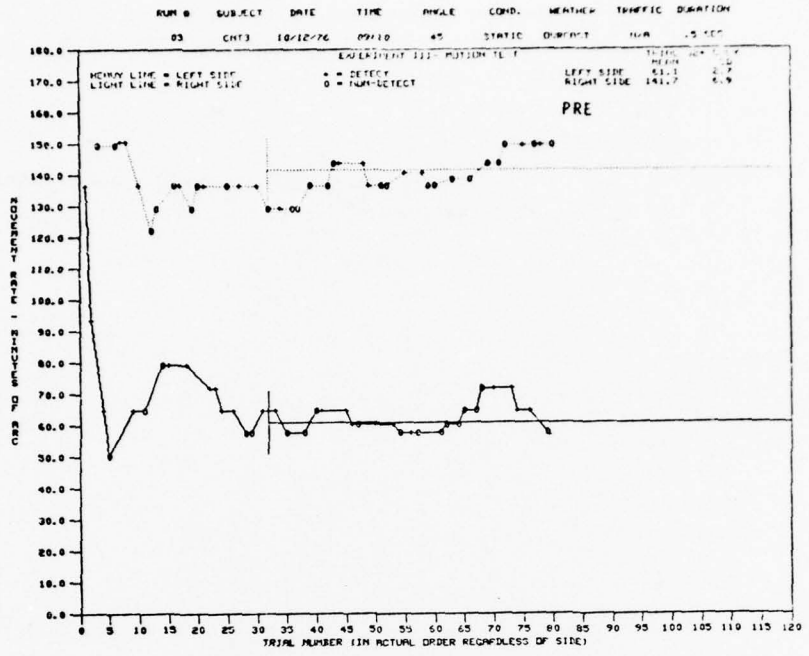

Figure B-43. Motion detection performance for pretesting (upper graph) and posttesting (lower graph). Mean thresholds are indicated by horizontal straight lines.

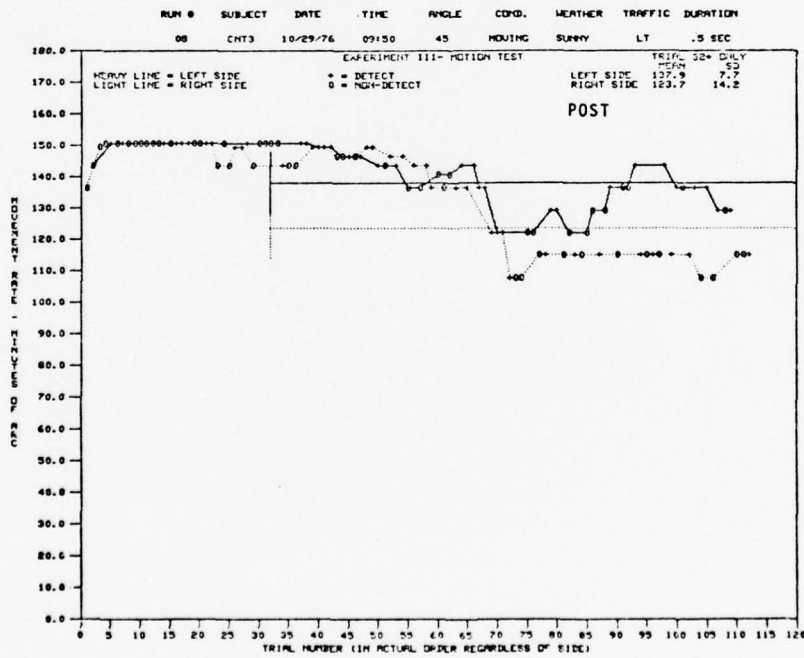
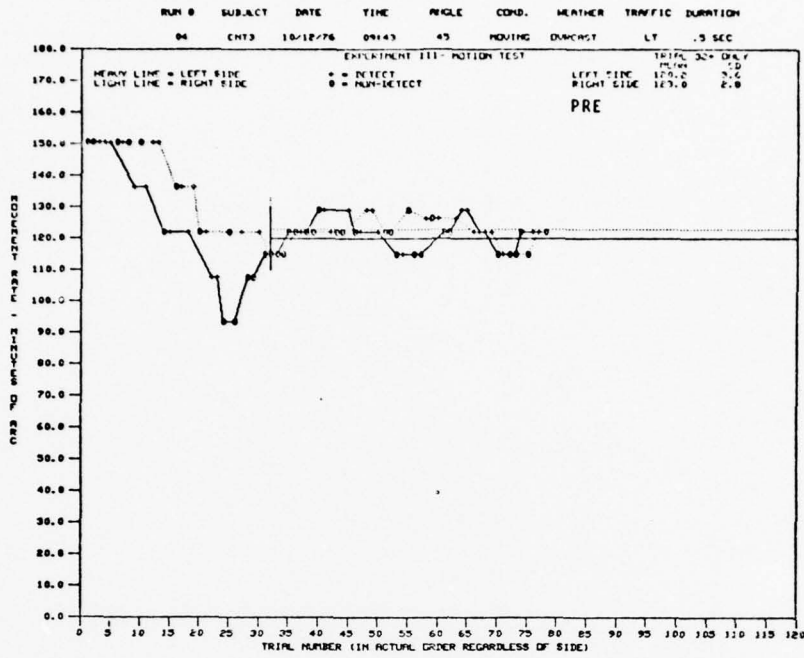

Figure B-44. Motion detection performance for pretesting (upper graph) and posttesting (lower graph). Mean thresholds are indicated by horizontal straight lines.

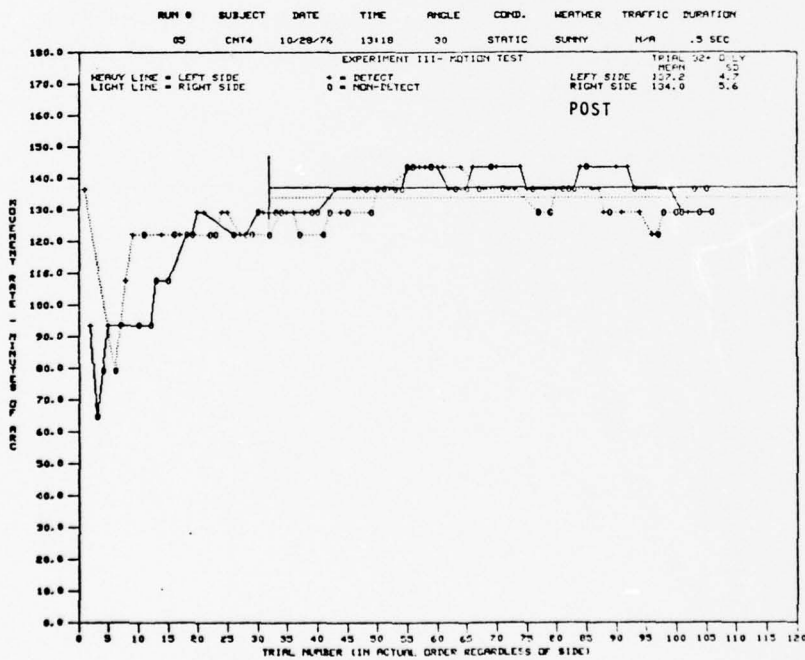
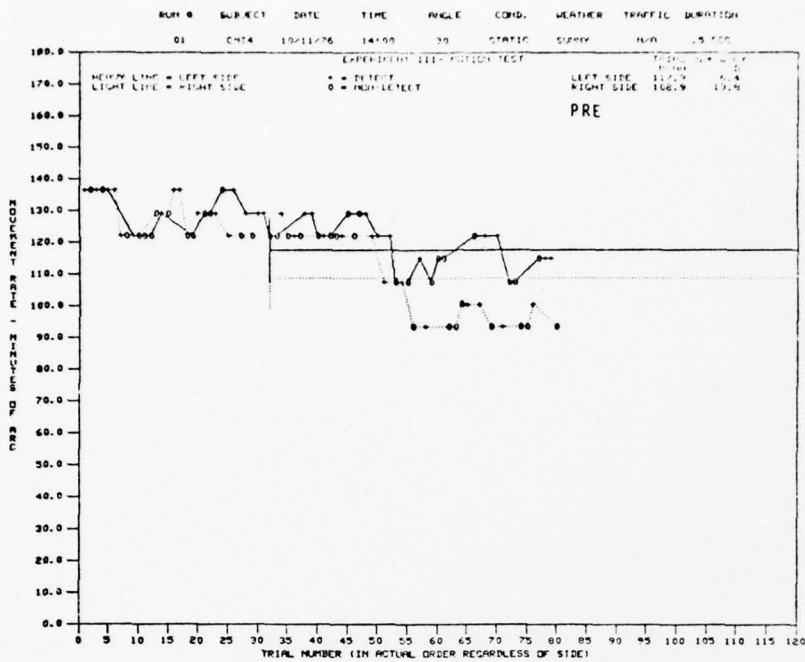

Figure B-45. Motion detection performance for pretesting (upper graph) and posttesting (lower graph). Mean thresholds are indicated by horizontal straight lines.

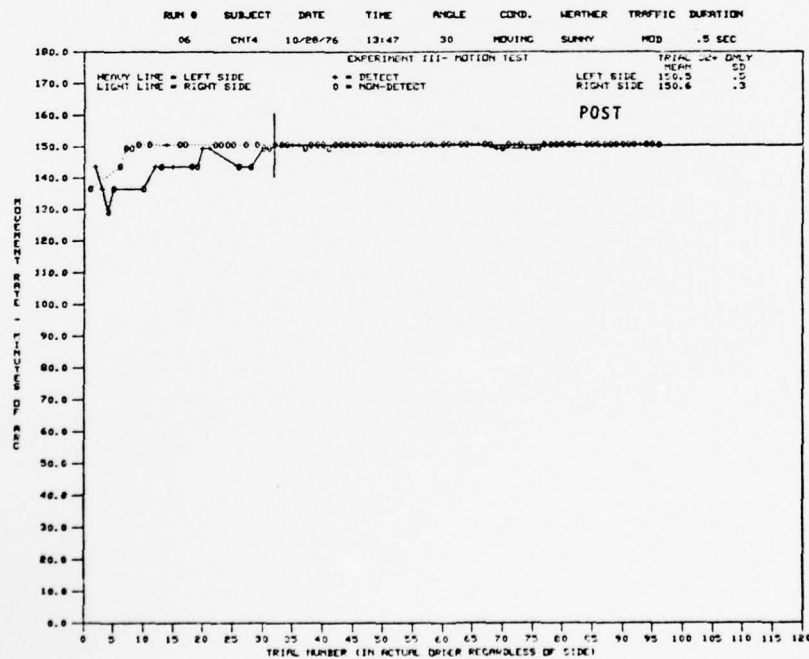
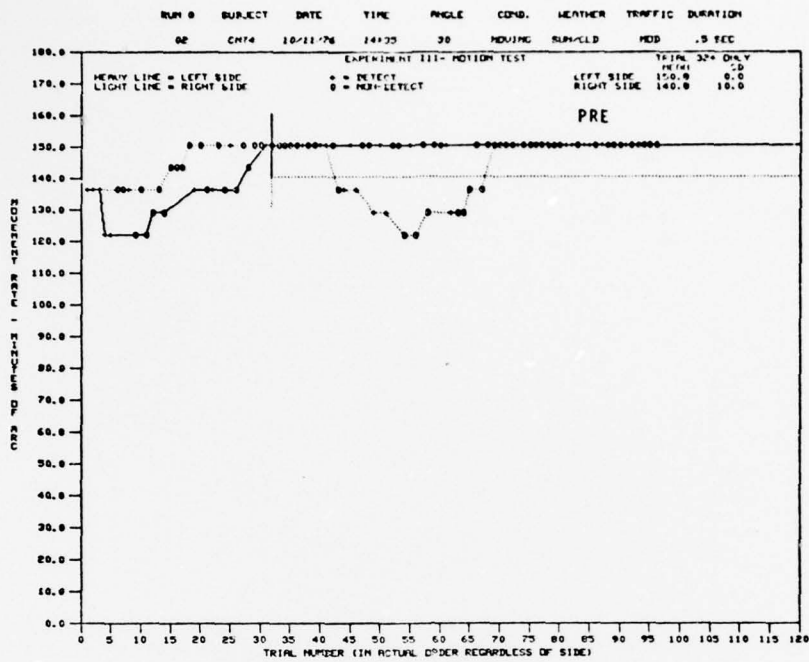

Figure B-46. Motion detection performance for pretesting (upper graph) and posttesting (lower graph). Mean thresholds are indicated by horizontal straight lines.

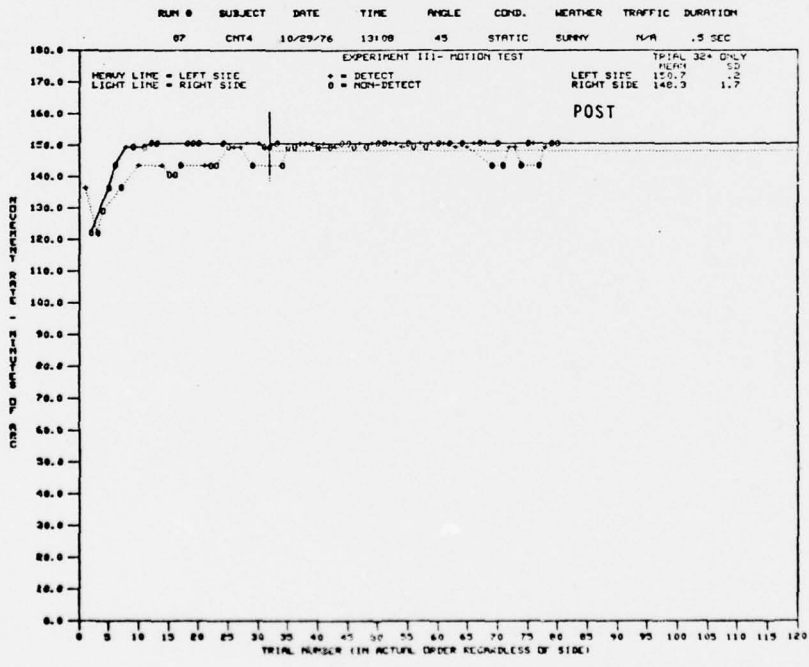
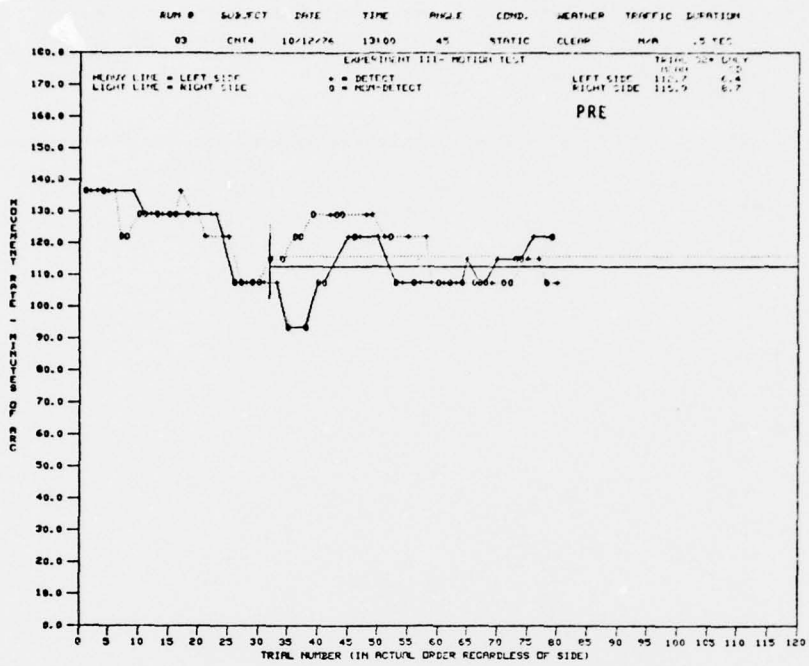

Figure B-47. Motion detection performance for pretesting (upper graph) and posttesting (lower graph). Mean thresholds are indicated by horizontal straight lines.

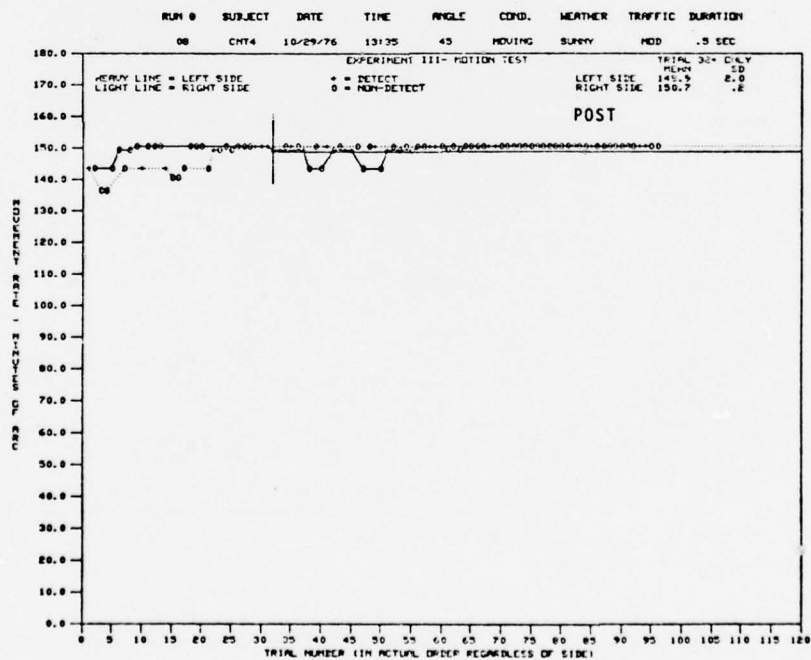
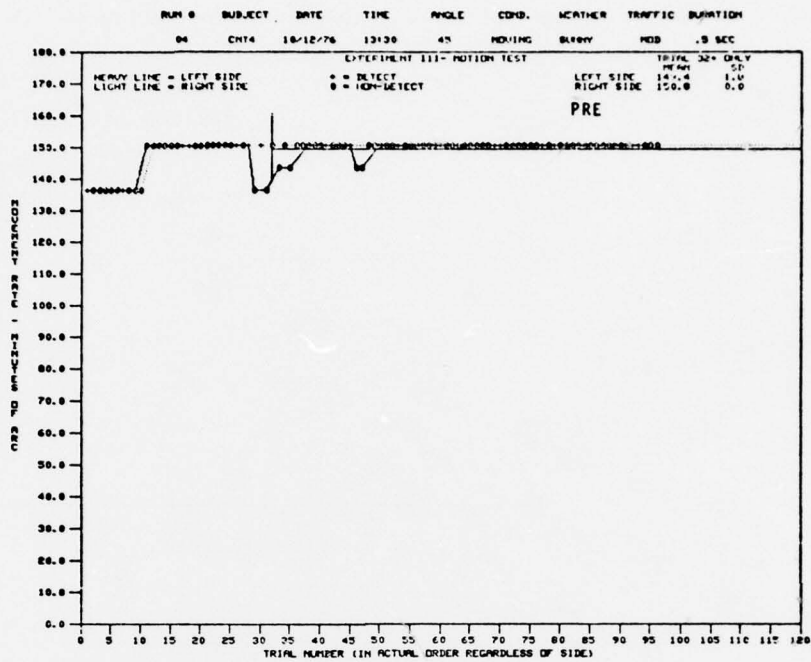

Figure B-48. Motion detection performance for pretesting (upper graph) and posttesting (lower graph). Mean thresholds are indicated by horizontal straight lines.

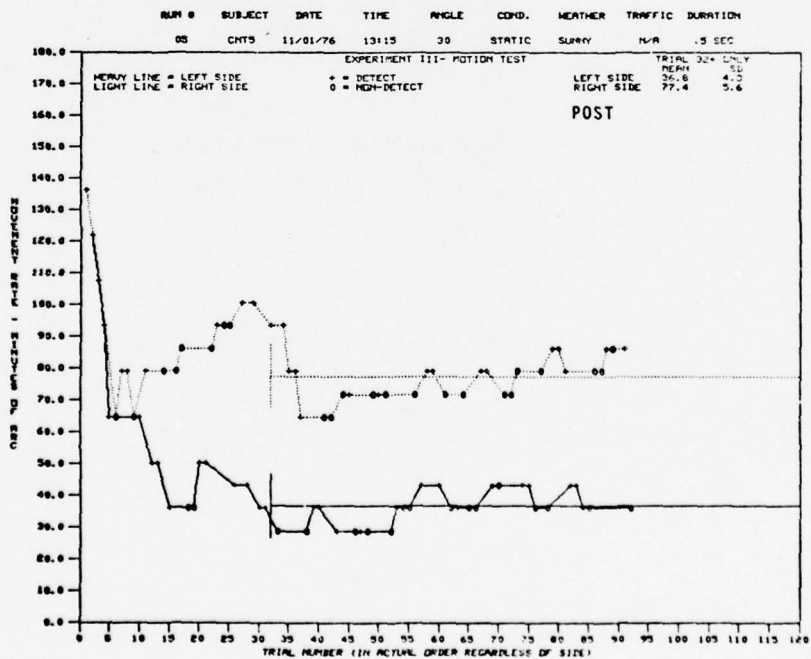
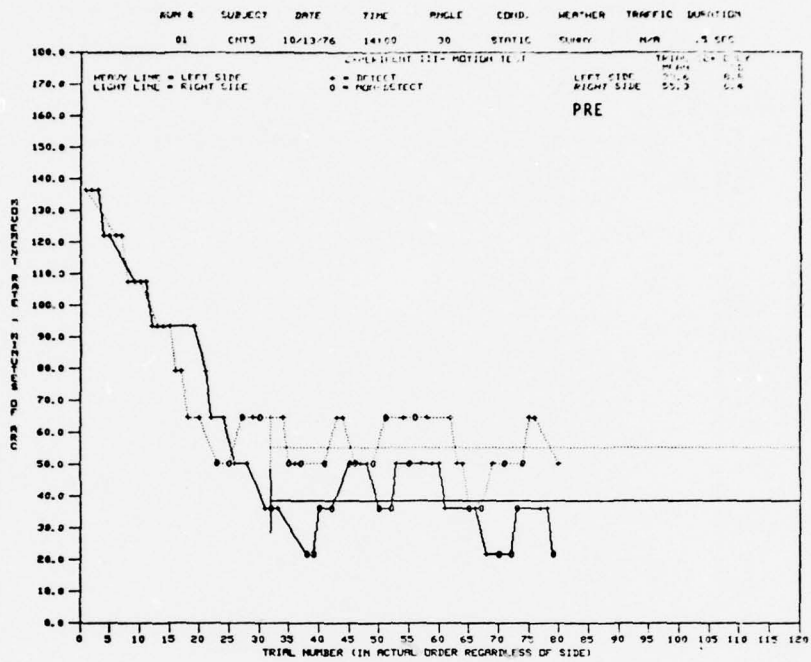

Figure B-49. Motion detection performance for pretesting (upper graph) and posttesting (lower graph). Mean thresholds are indicated by horizontal straight lines.

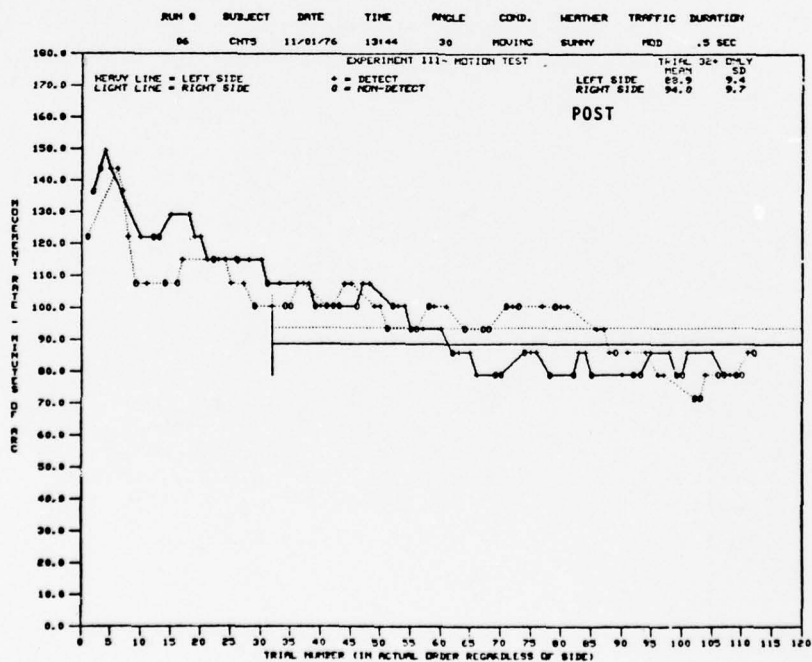
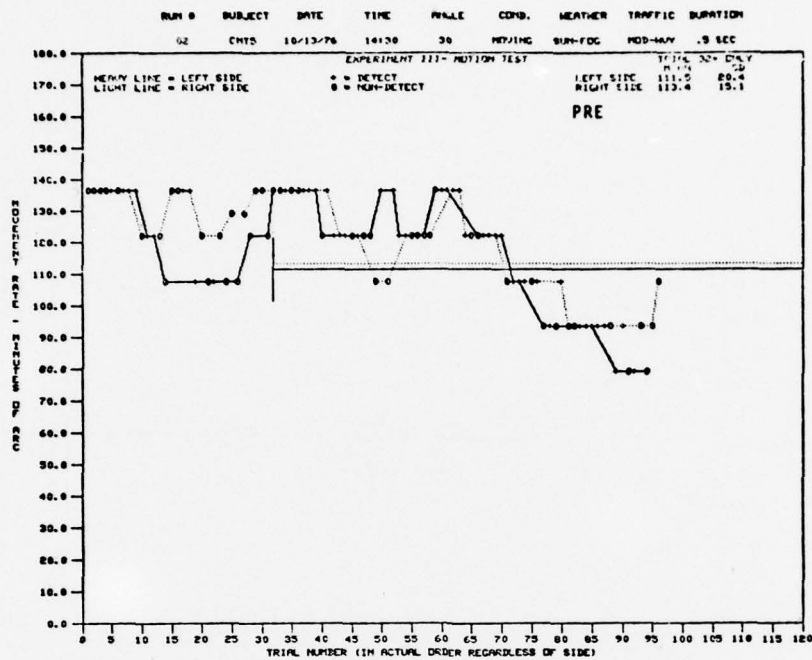

Figure B-50. Motion detection performance for pretesting (upper graph) and posttesting (lower graph). Mean thresholds are indicated by horizontal straight lines.

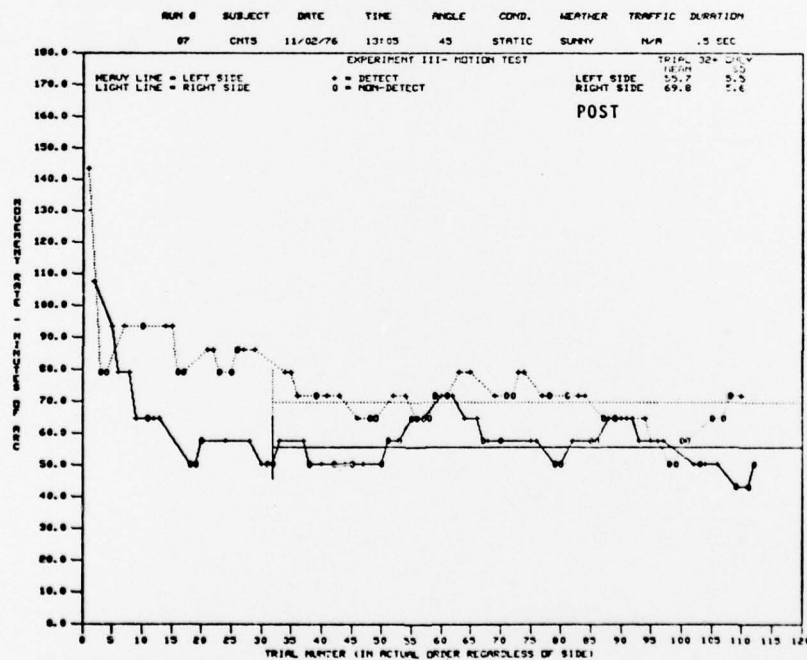
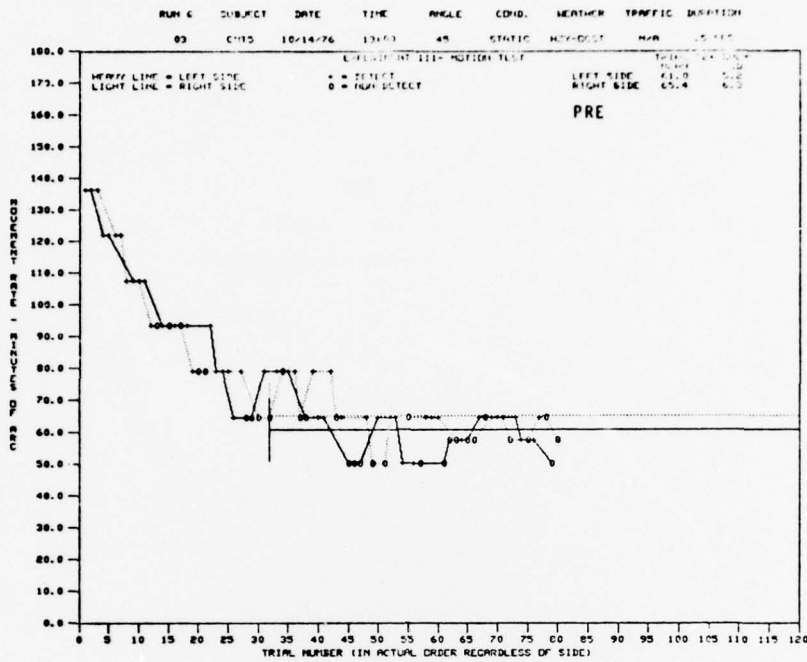

Figure B-51. Motion detection performance for pretesting (upper graph) and posttesting (lower graph). Mean thresholds are indicated by horizontal straight lines.

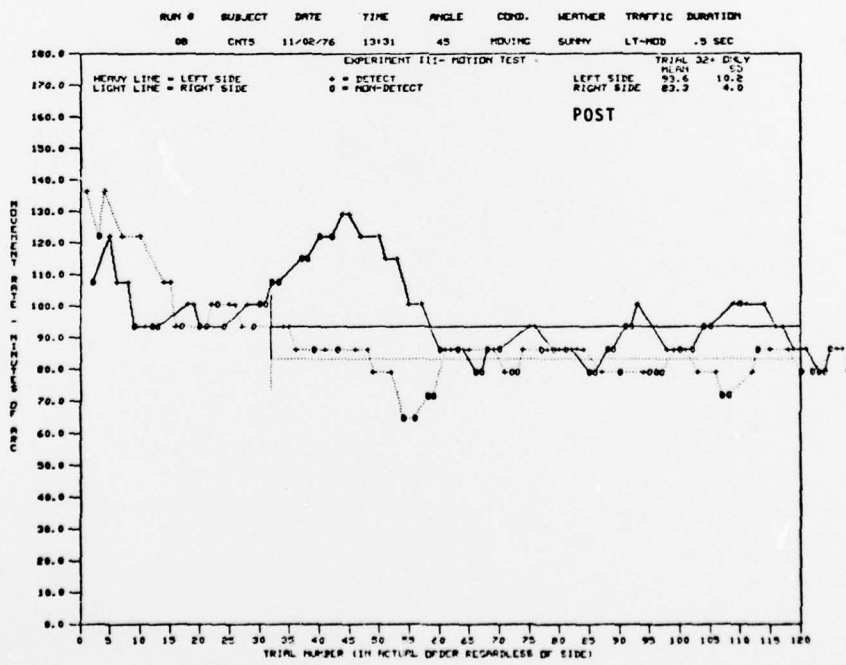
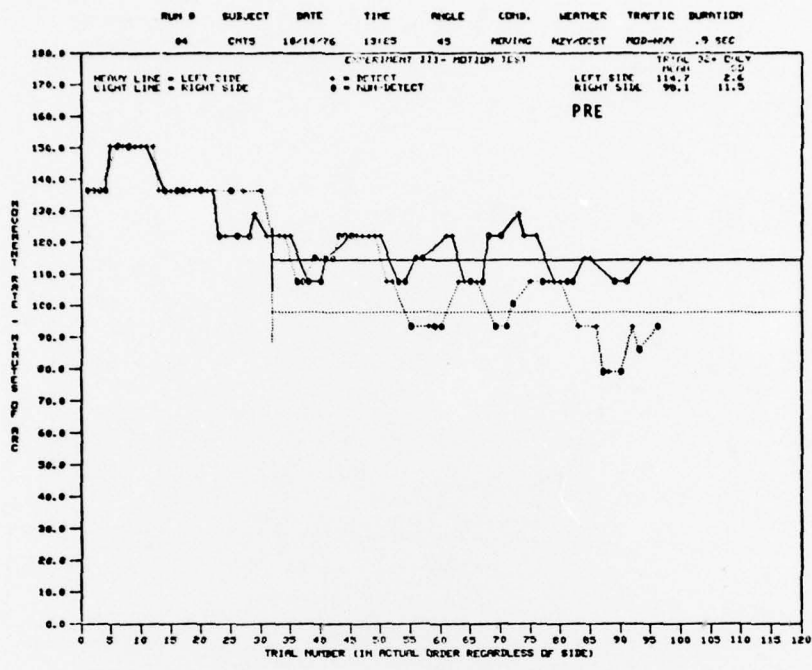

Figure B-52. Motion detection performance for pretesting (upper graph) and posttesting (lower graph). Mean thresholds are indicated by horizontal straight lines.

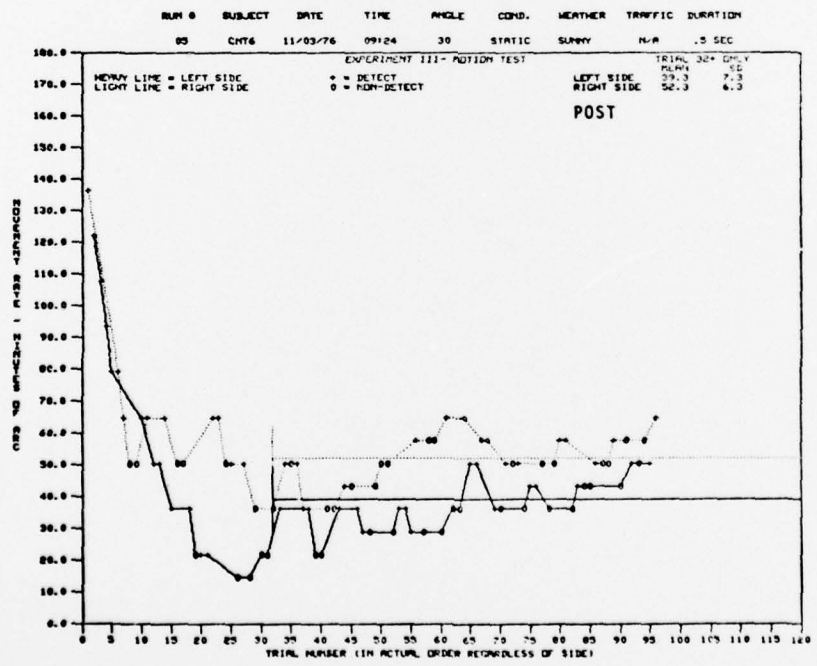
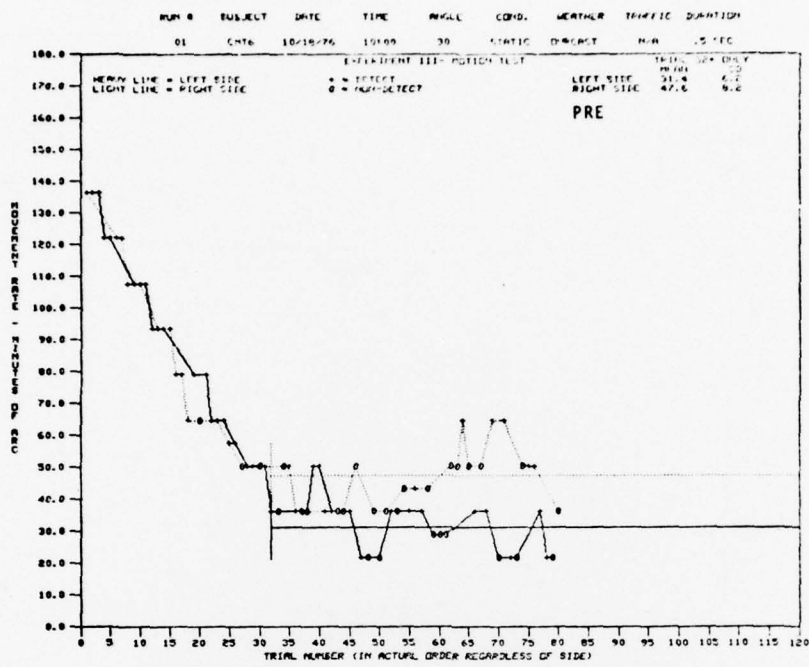

Figure B-53. Motion detection performance for pretesting (upper graph) and posttesting (lower graph). Mean thresholds are indicated by horizontal straight lines.

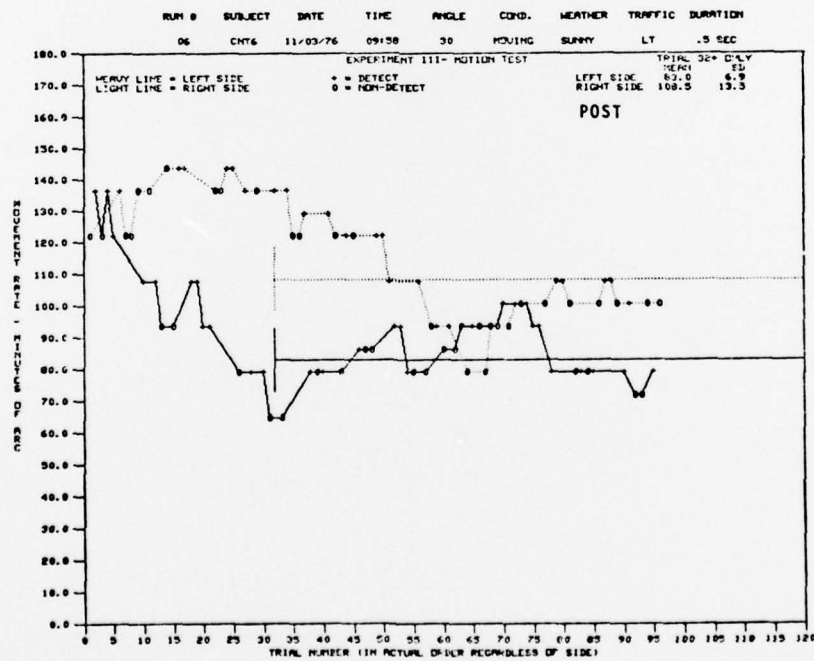
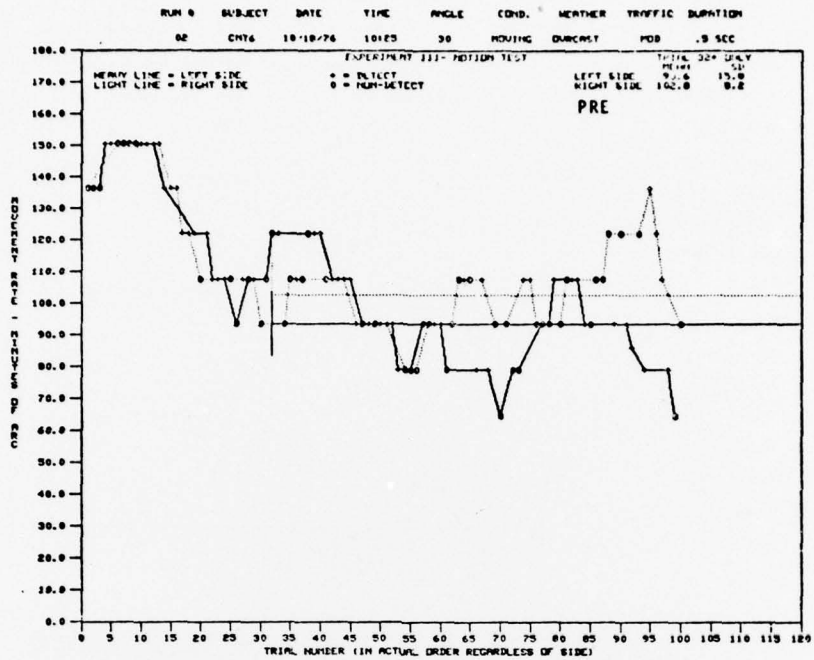

Figure B-54. Motion detection performance for pretesting (upper graph) and posttesting (lower graph). Mean thresholds are indicated by horizontal straight lines.

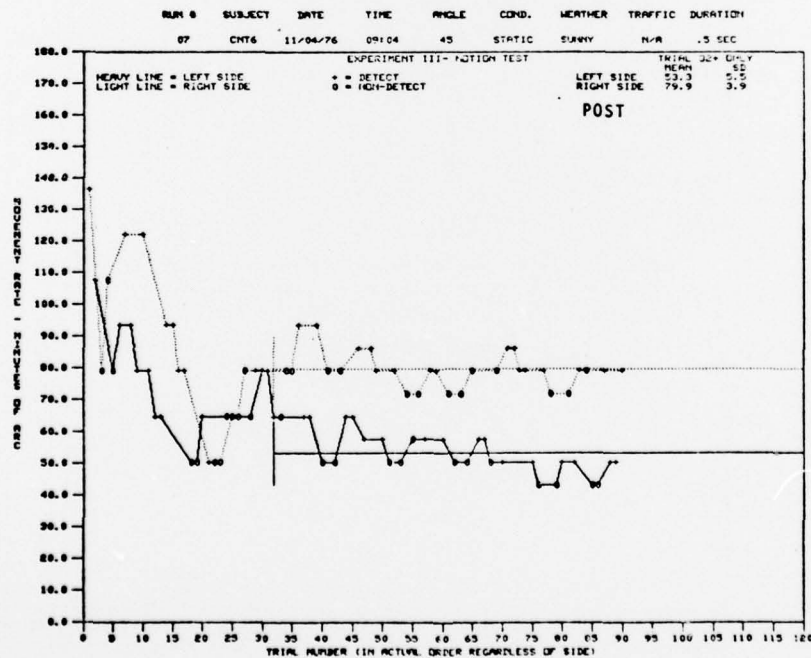
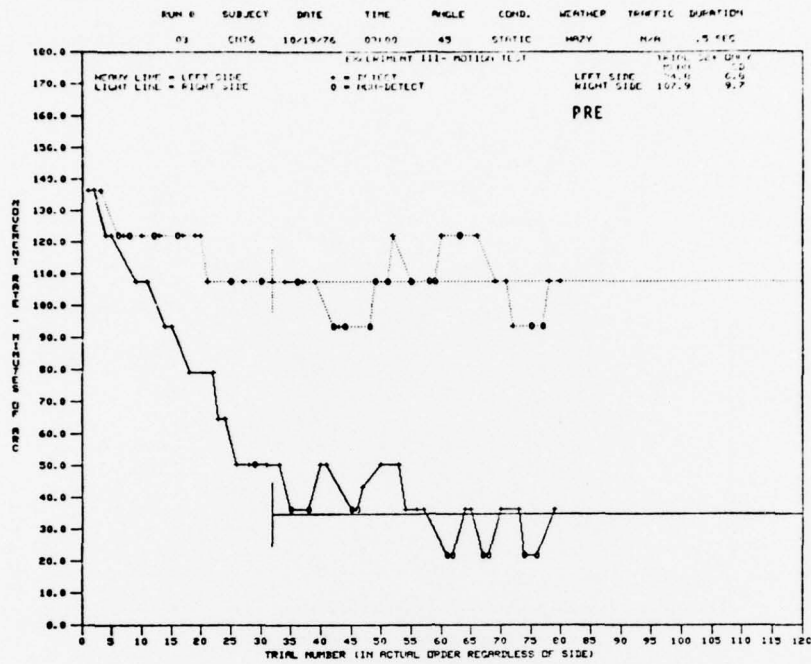

Figure B-55. Motion detection performance for pretesting (upper graph) and posttesting (lower graph). Mean thresholds are indicated by horizontal straight lines.

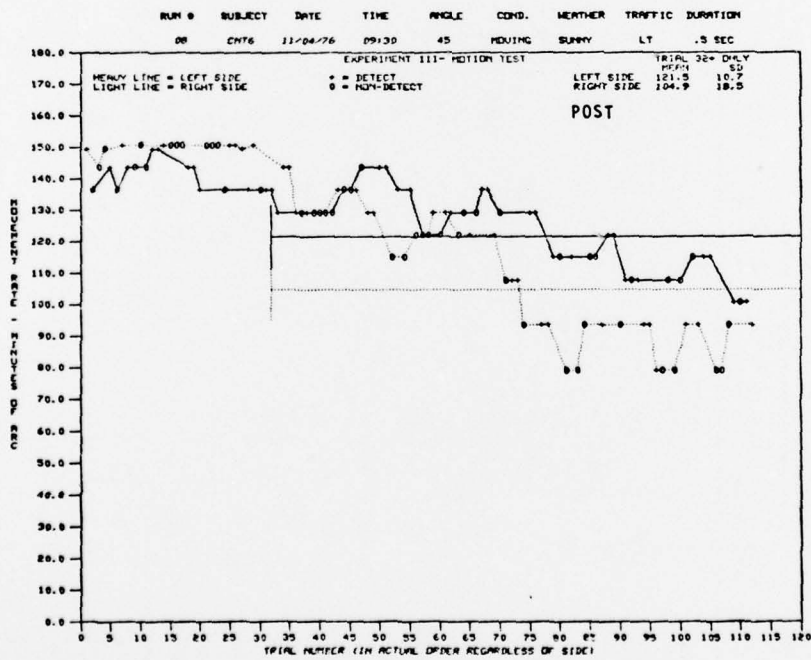
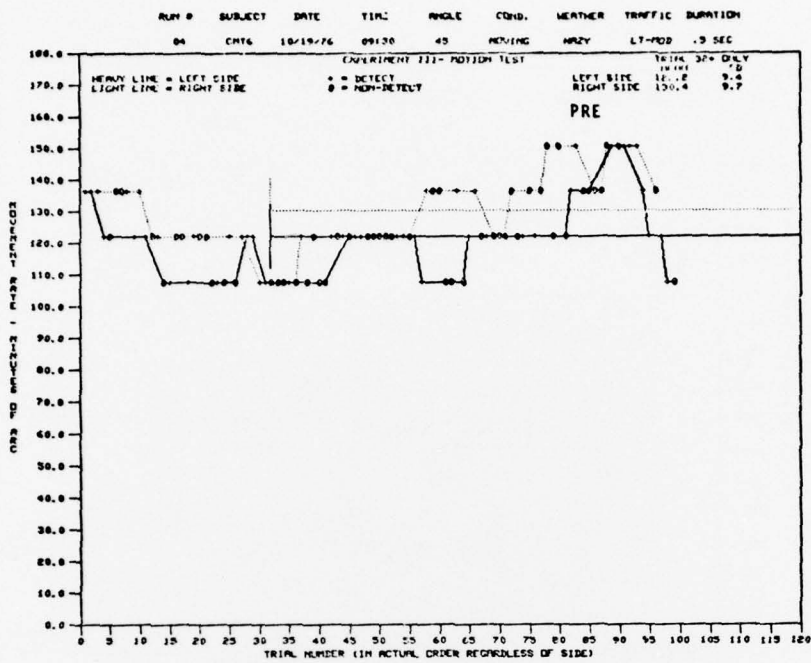

Figure B-56. Motion detection performance for pretesting (upper graph) and posttesting (lower graph). Mean thresholds are indicated by horizontal straight lines.

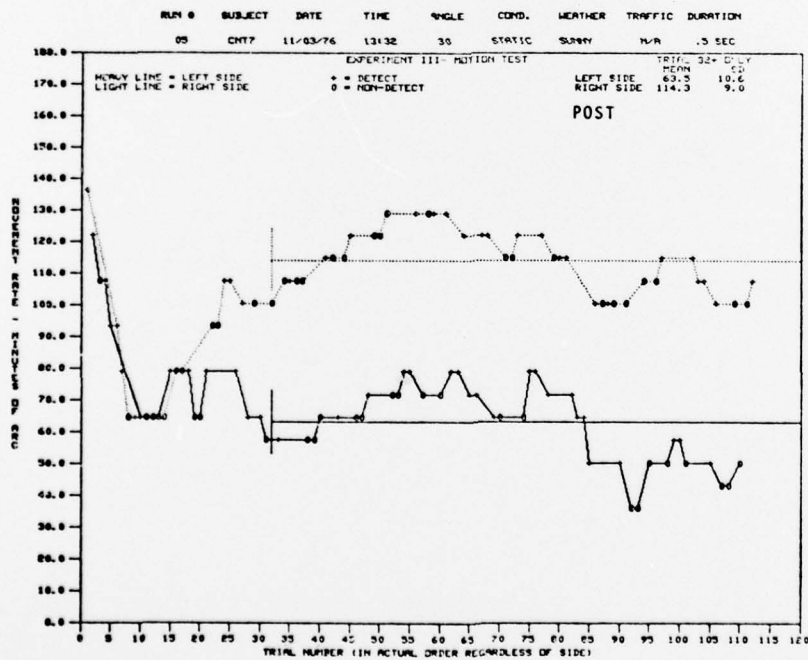
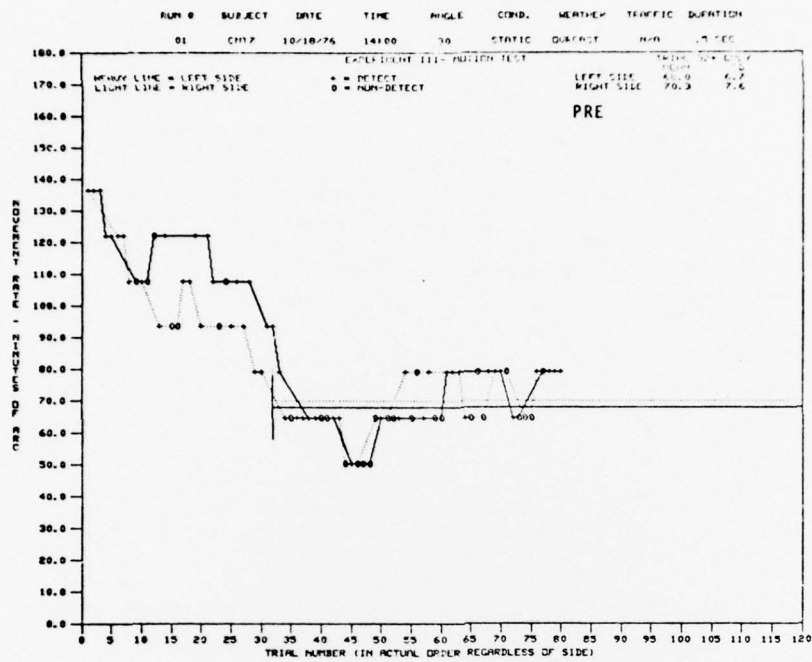

Figure B-57. Motion detection performance for pretesting (upper graph) and posttesting (lower graph). Mean thresholds are indicated by horizontal straight lines.

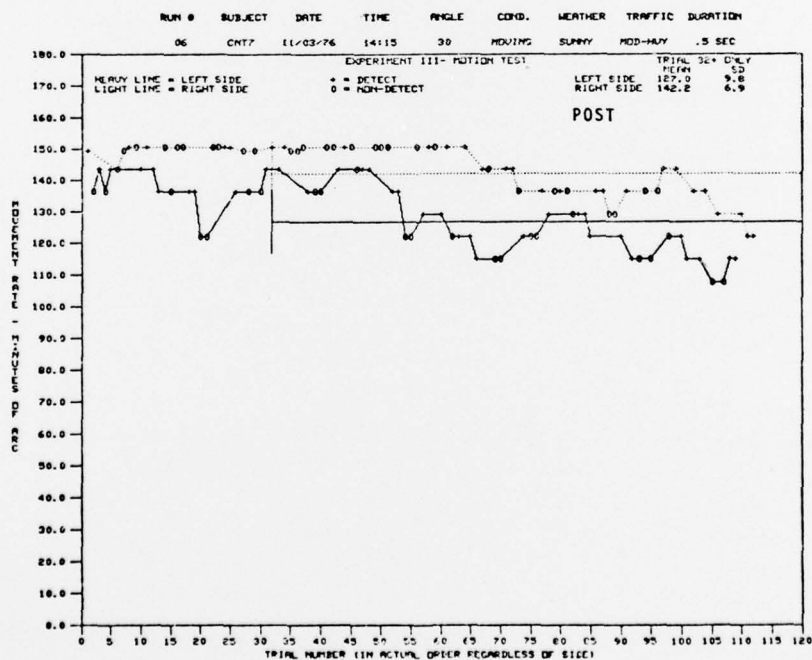
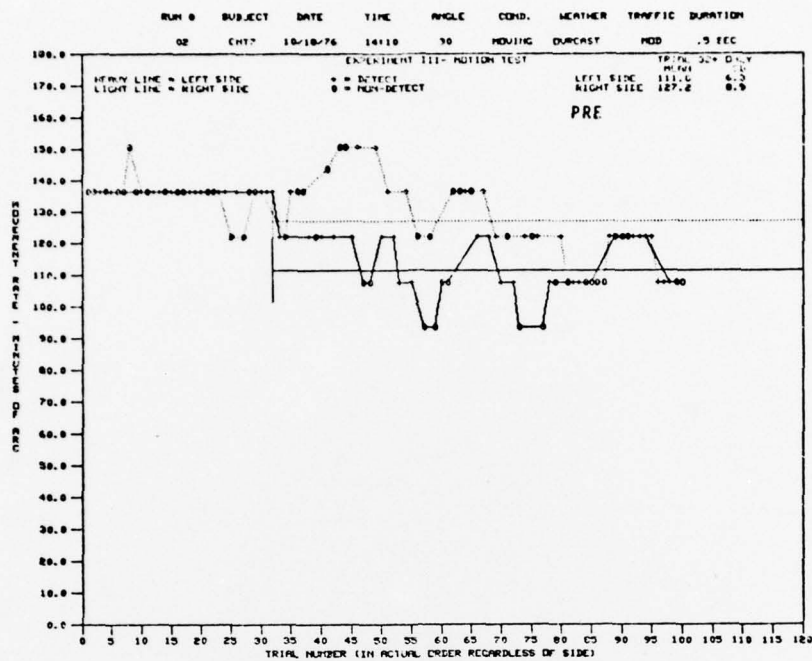

Figure B-58. Motion detection performance for pretesting (upper graph) and posttesting (lower graph). Mean thresholds are indicated by horizontal straight lines.

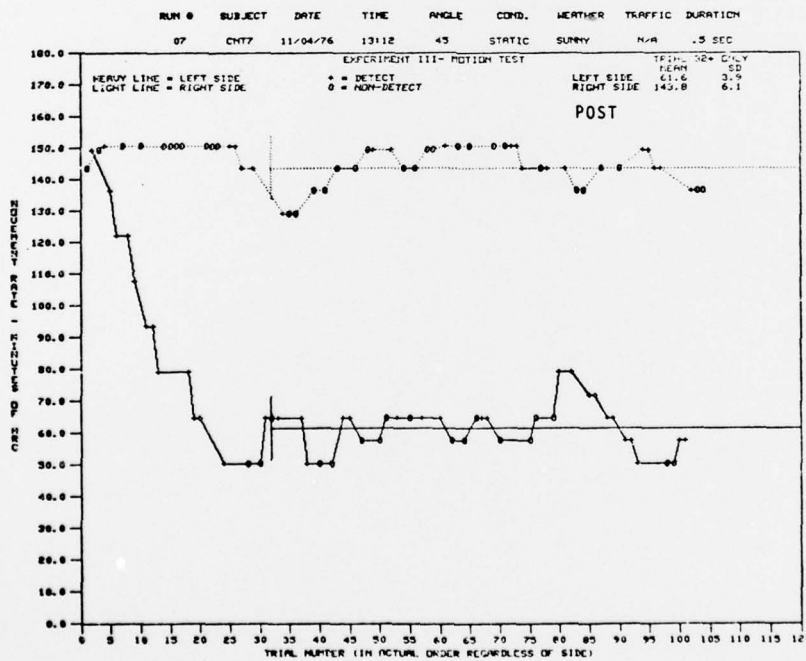
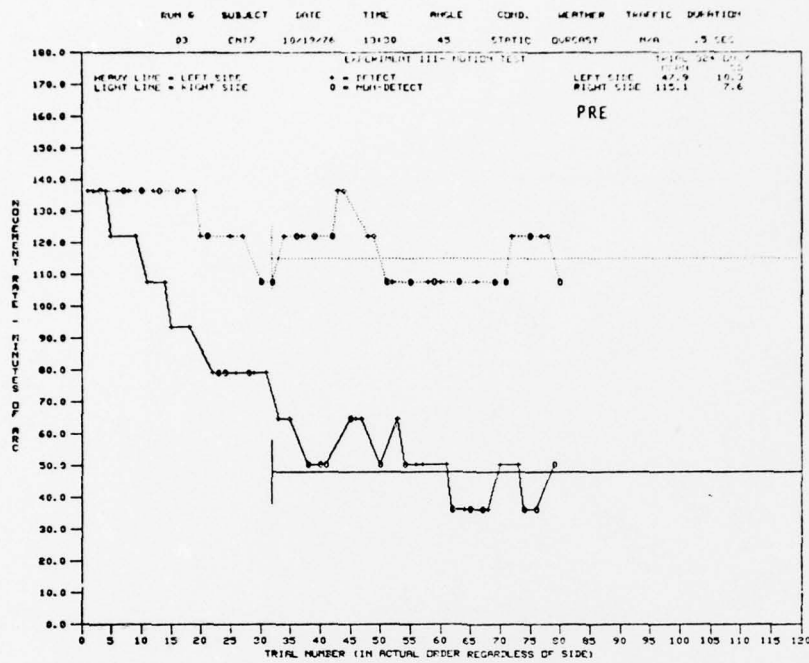

Figure B-59. Motion detection performance for pretesting (upper graph) and posttesting (lower graph). Mean thresholds are indicated by horizontal straight lines.

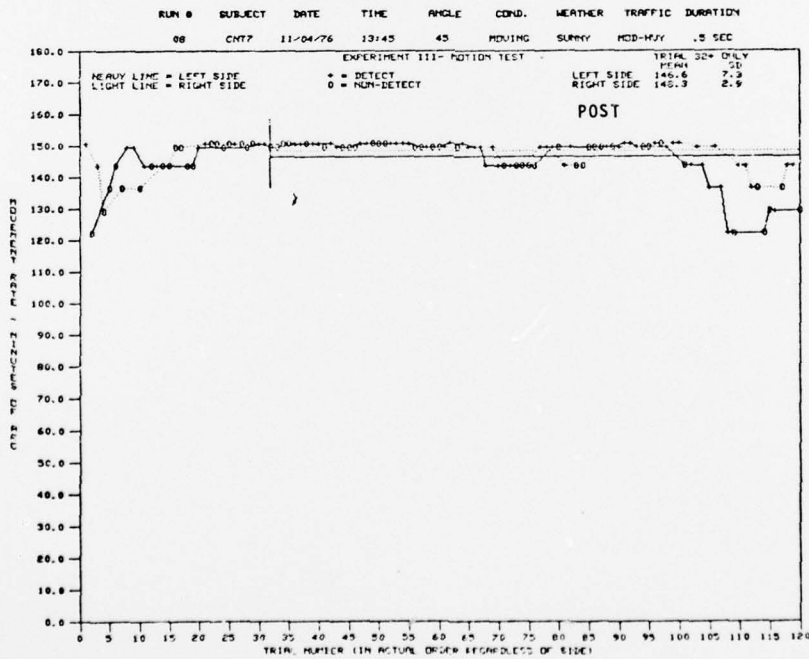
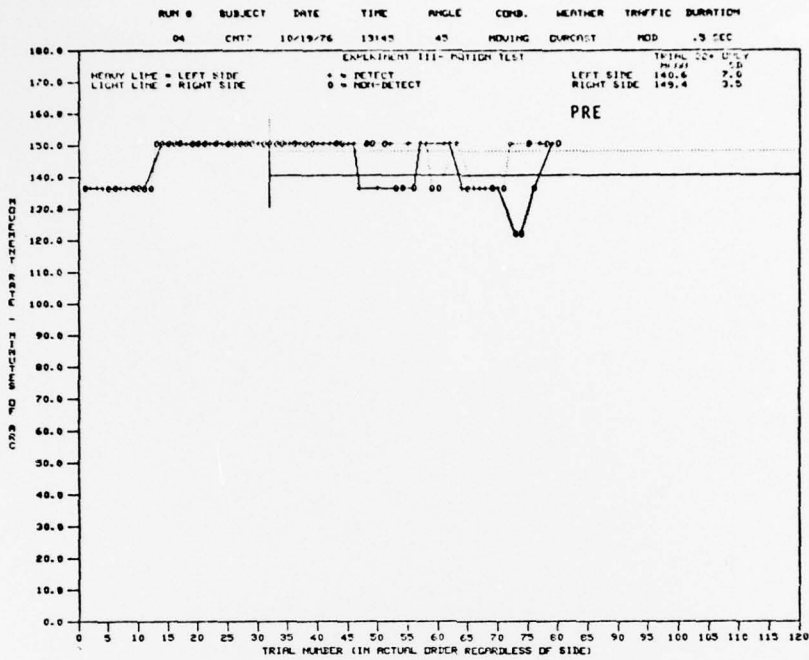

Figure B-60. Motion detection performance for pretesting (upper graph) and posttesting (lower graph). Mean thresholds are indicated by horizontal straight lines.

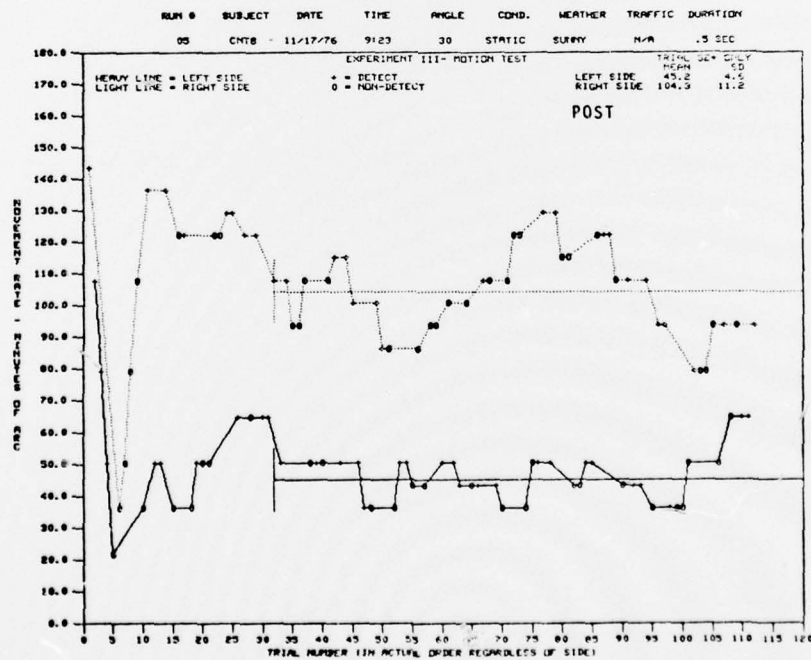
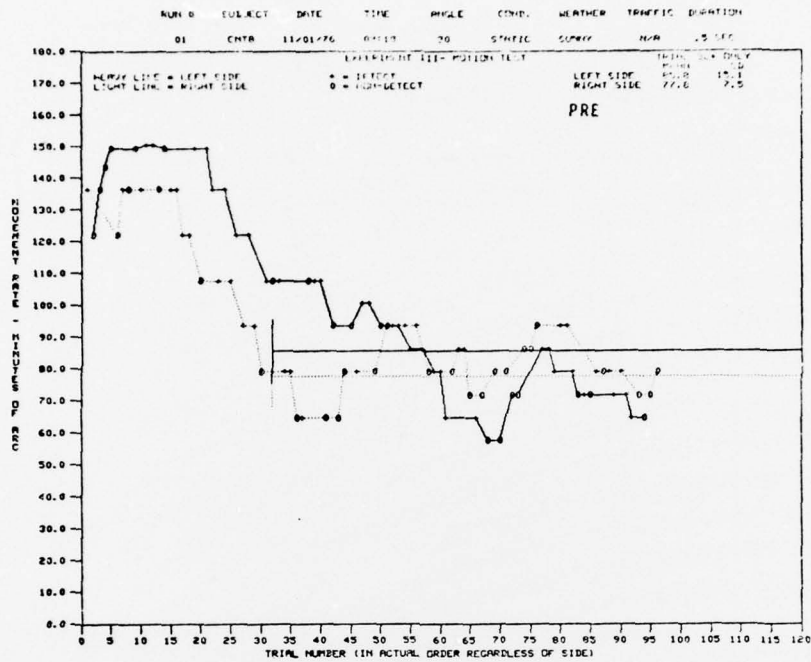

Figure B-61. Motion detection performance for pretesting (upper graph) and posttesting (lower graph). Mean thresholds are indicated by horizontal straight lines.

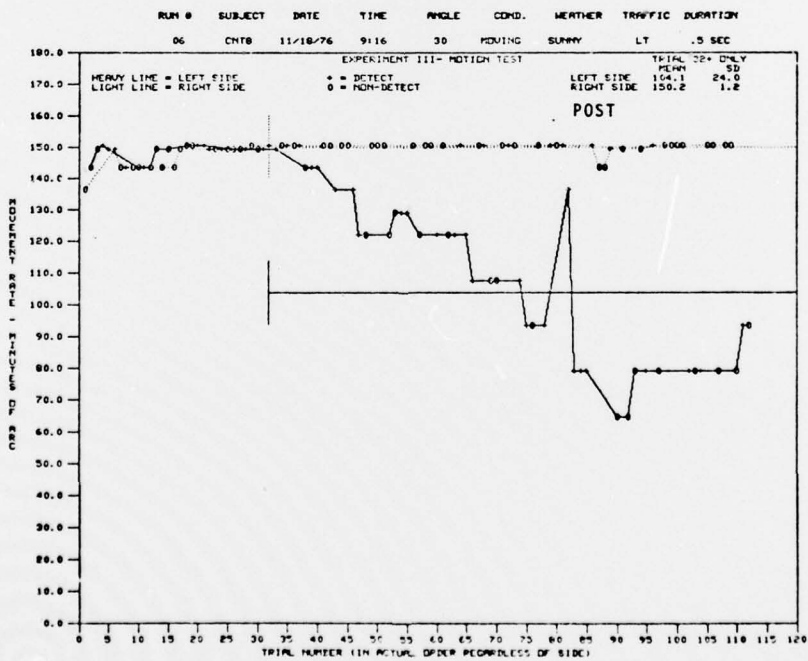
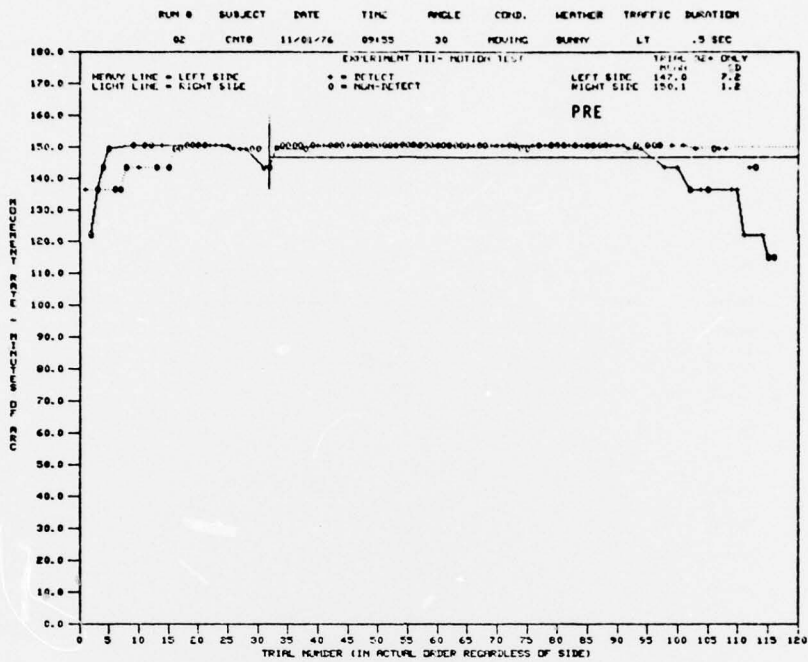

Figure B-62. Motion detection performance for pretesting (upper graph) and posttesting (lower graph). Mean thresholds are indicated by horizontal straight lines.

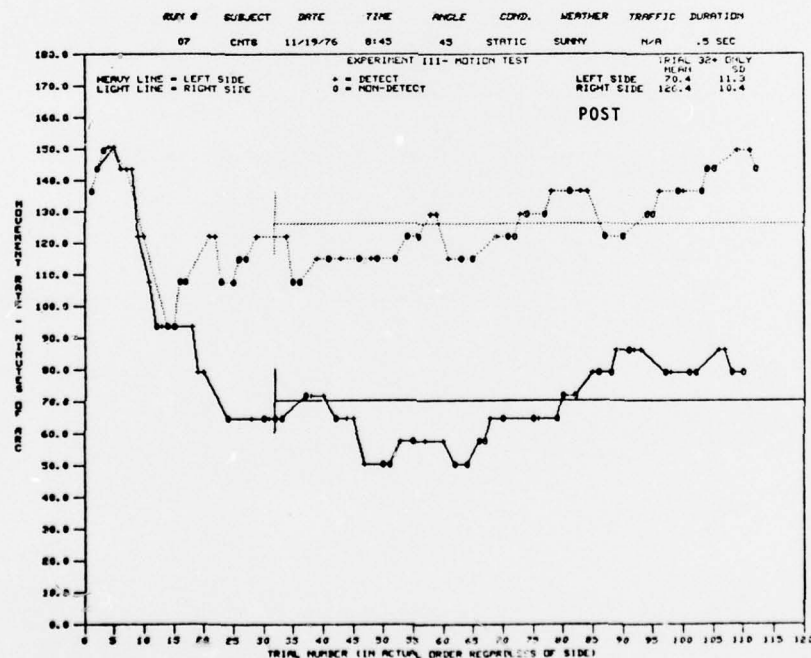
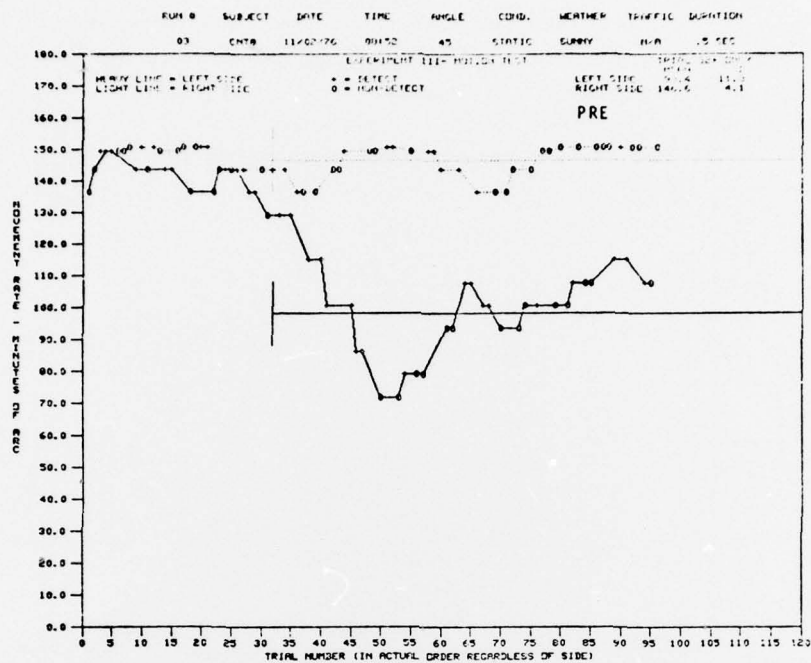

Figure B-63. Motion detection performance for pretesting (upper graph) and posttesting (lower graph). Mean thresholds are indicated by horizontal straight lines.

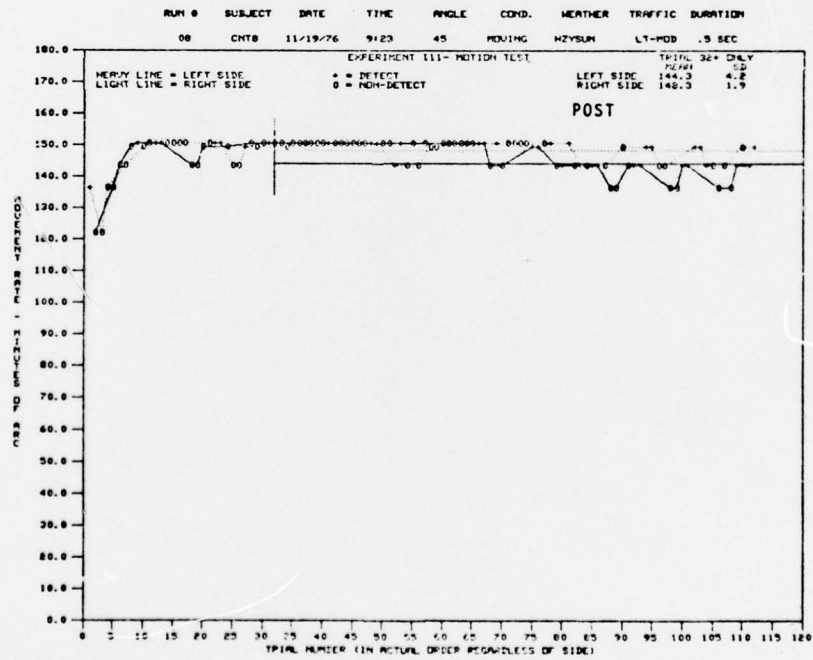
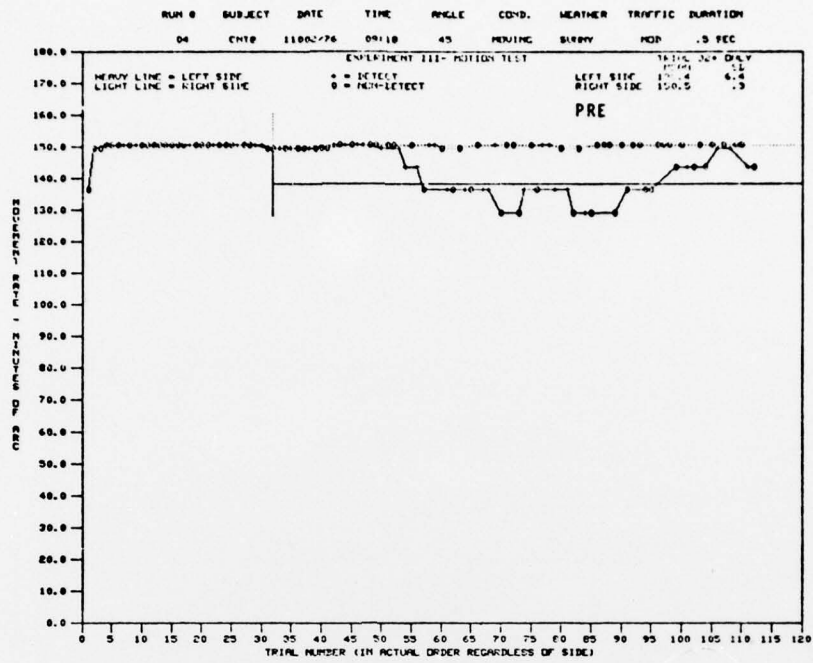

Figure B-64. Motion detection performance for pretesting (upper graph) and posttesting (lower graph). Mean thresholds are indicated by horizontal straight lines.